

Internal Connection Diagrams

• Internal Connections for Speed/Torque Control

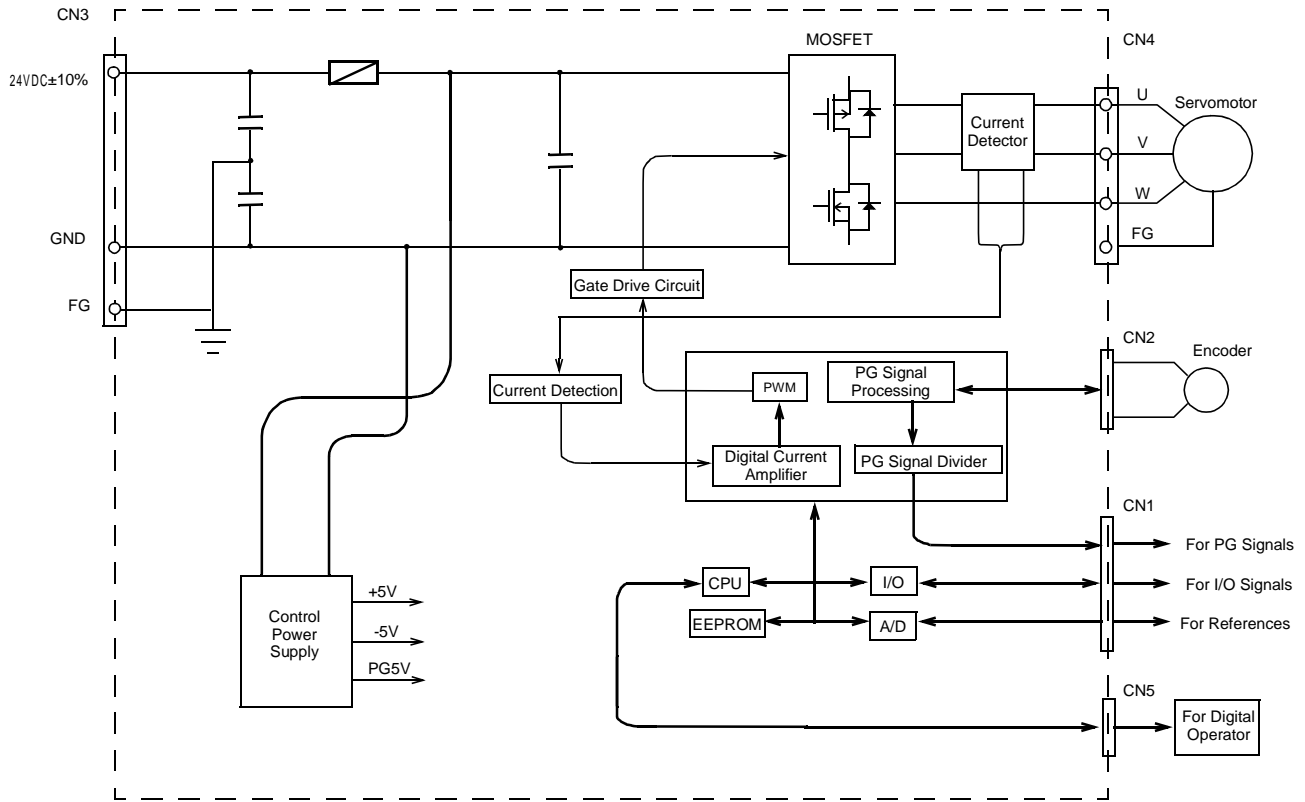

• Internal Connections for Position Control

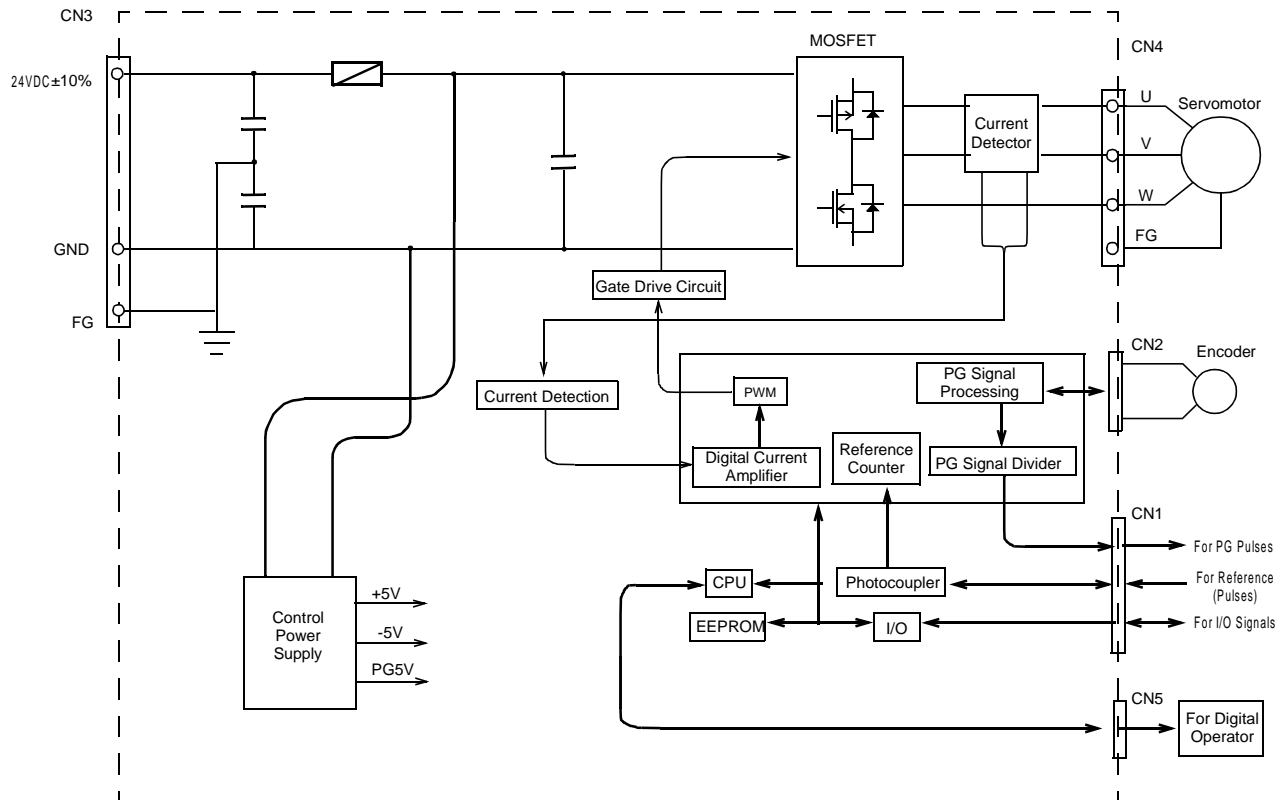

Internal Connection Diagram

Encoder Signal (2CN) Connections

- Connector 2CN for Incremental Encoder Connection and 1CN Output Processing

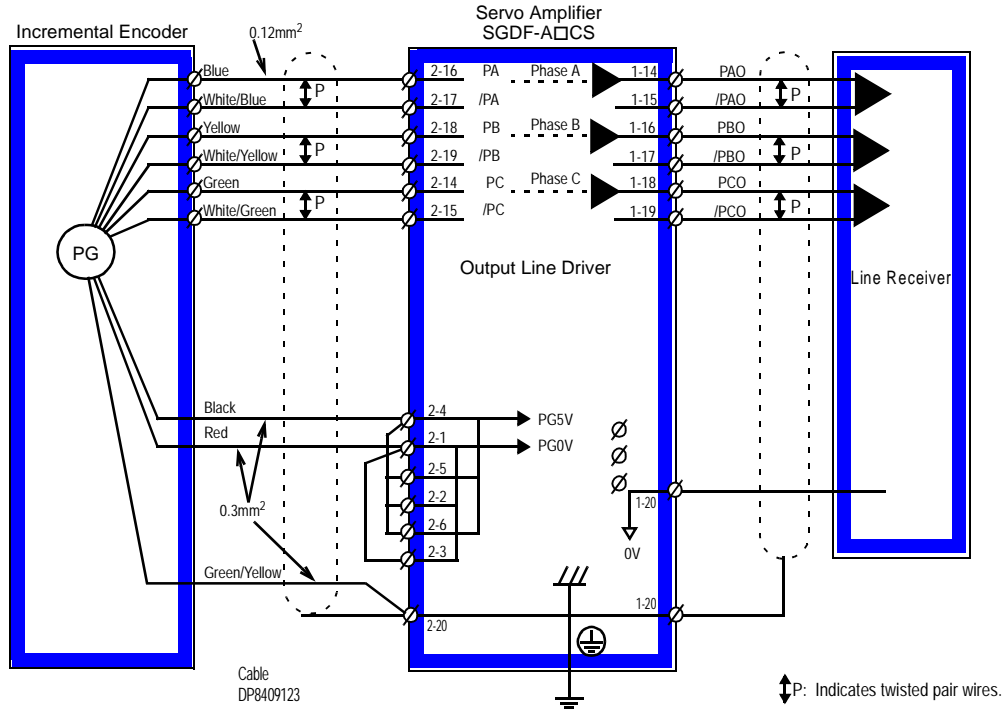

SGDF

Internal Connection Diagram

- Connection Example: SGDF servo amplifier (SGDF-□□CS), SGMM servomotor (with incremental encoder), and peripheral devices.

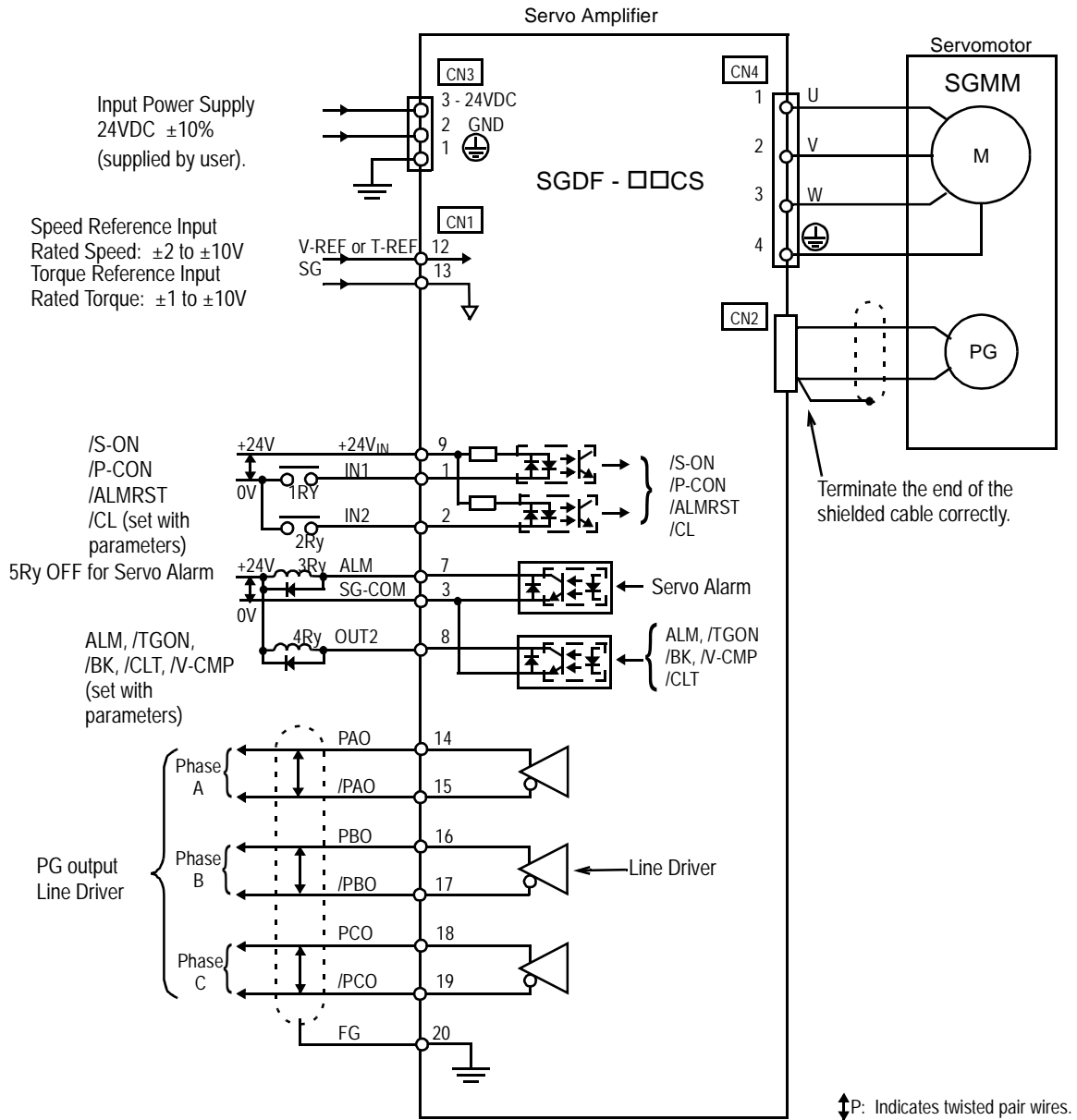

Note: The capacity of each output circuit is less than 30VDC and 50mA.

Internal Connection Diagram

- Connection Example: SGDF servo amplifier (SGDF-□□CP), SGMM servomotor (with incremental encoder), and peripheral devices.

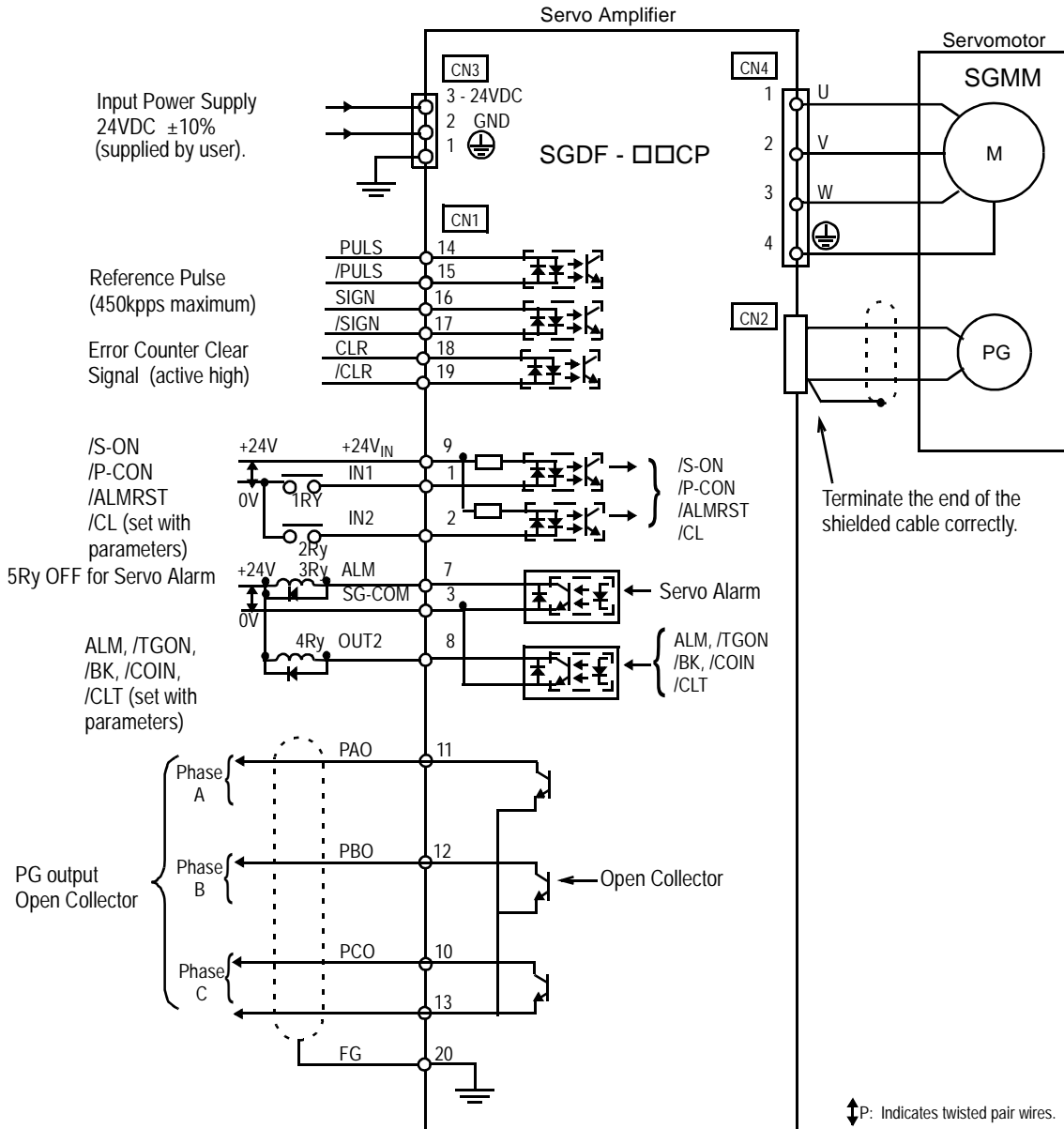

Note: The capacity of each output circuit is less than 30VDC and 50mA.