

ENGINEERING PUBLICATION
MOTION CONTROL DIVISION

PRODUCT: SGDV, OCA01A, TWINCAT, BECKHOFF IPC C6330

SUBJECT: SIGMA-5 ETHERCAT WITH TWINCAT

CATEGORY: APPLICATION NOTE

ENGINEER: DEREK LEE

DISTRIBUTION: PUBLIC

Abstract:

This document details the setup procedure used to run a Sigma-5 CANopen over EtherCAT (CoE) Amplifier using TwinCAT on a Beckhoff Industrial PC.



Yaskawa SGDV with
EtherCAT option module

+



Computer
(Ex: Beckhoff IPC C6330)

+



TwinCAT
(Ex: v.2.10, Build 1335)

Table of Contents:

1. Prerequisites

Part I: Configuring TwinCAT

2. Obtain XML File
3. Relocate XML File
4. Update XML Library
5. Set up Ethernet Adapter for Real-Time Communications

Part II: Configuring & Wiring the Sigma-5 CoE Amplifier

6. SERVOPACK Alarms & Warnings
7. Tune Motor
8. Wire Connections

Part III: Optional EtherCAT Settings

9. Distributed Clocks
10. Manual Axis Addressing

1. Prerequisites

- TwinCAT must be installed on the computer. TwinCAT NC PTP is recommended.
- The Yaskawa SGD V Amplifier must be wired for power.
- A supported network controller is recommended. The full list can be found in the Beckhoff Information System in the following location: Beckhoff Information System > TwinCAT > TwinCAT System Manager > Reference > I/O Devices > EtherCAT(Direct Mode) > Supported network controller.
- SigmaWin+ v.5.31 recommended. At minimum, SigmaWin+ v.5.21 required for tuning.

PART I: Configuring TwinCAT

2. Obtain XML File

The XML File can be downloaded from Yaskawa's Web Page.

Yaskawa's Web Page: <http://www.yaskawa.com>.

The file is named:

Yaskawa SGD V-E1_CoE v1.00.xml

Save the file to the computer.

3. Relocate XML File

Relocate the XML file into the TwinCAT IO EtherCAT directory.

TwinCAT's default path is:

C:\TwinCAT\Io\EtherCAT

See image below for reference.

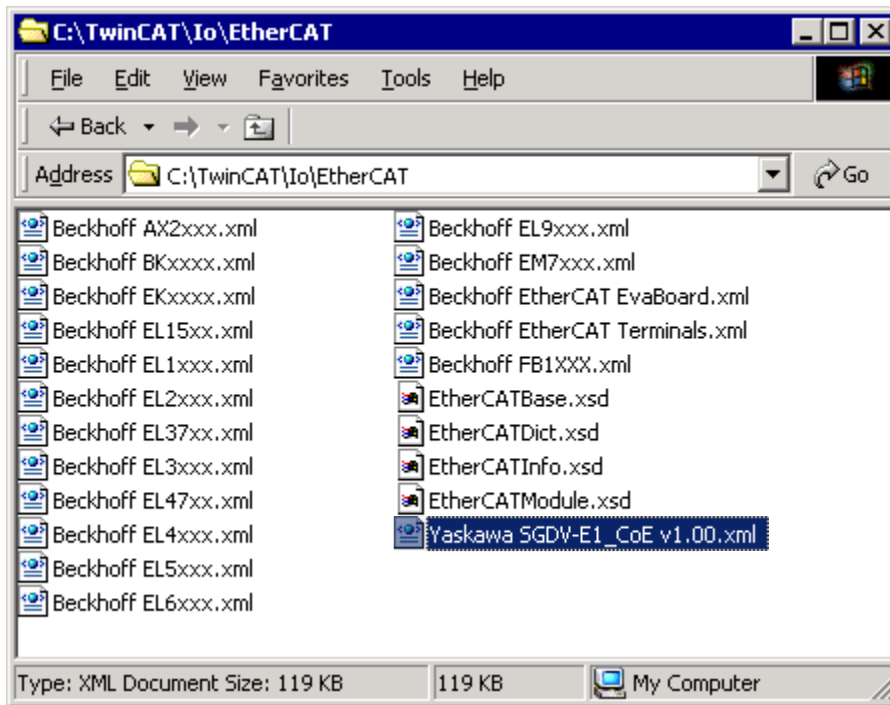

4. Update XML Library

To guarantee that TwinCAT will update the XML Library, restart the computer.

5. Set up Ethernet Adapter for Real-Time Communications

If the Ethernet Adapter has not been installed to be used with TwinCAT (for instance, if this is the first time the Ethernet Adapter will be used for EtherCAT communications through TwinCAT on the computer), refer to Appendix Section 1: *Setting up the Ethernet Adapter for Real-Time Communications*.

PART 1 Summary:

TwinCAT is now configured to be able to detect the Sigma-5 CoE Amplifier.

PART II: Configuring & Wiring the Sigma-5 CoE Amplifier

6. SERVOPACK Alarms & Warnings

The most common startup alarms and warnings are addressed below.

Alarm: A.810 "Encoder Backup Error"
--

4 Solutions:

1. Use encoder as Incremental instead of Absolute. Set Pn002.2 = 1 (can be accomplished using a digital operator, SigmaWin+, or through EtherCAT).
2. Use a digital operator (JUSP-OP05A-1-E) to reset the absolute encoder.
See Appendix Section 2.1: *Using a Digital Operator to Reset Absolute Encoder*.
3. Use SigmaWin+ to reset the absolute encoder.
See Appendix Section 2.2: *Using SigmaWin+ to Reset Absolute Encoder*.
4. Use CoE to reset the absolute encoder.
See Appendix Section 2.3: *Using CoE to Reset Absolute Encoder*.

Warning: P n "Forward/reverse run prohibited"
--

4 Solutions:

1. Recommended: Connect the inputs to a switch that changes state.
2. Use with caution: Use a digital operator to disable the inputs.
See Appendix Section 3.1: *Using a Digital Operator to Disable Overtravels*.
3. Use with caution: Use SigmaWin+ to disable the inputs.
See Appendix Section 3.2: *Using SigmaWin+ to Disable Overtravels*.
4. Use with caution: Use CoE to disable the inputs.
See Appendix Section 3.3: *Using CoE to Disable Overtravels*.

7. Tune Motor

The motor can be tuned using SigmaWin+ v.5.21 or above.

For tuning procedures, refer to Chapter 5 of the Σ -V Series *User's Manual Design and Maintenance Command Option Attachable Type* (Manual number SIEP S800000 60A).

8. Wire Connections

Connect an Ethernet cable from the SGDV-CoE option card's IN port to the computer's designated port for EtherCAT communications.

The EtherCAT IN port of the EtherCAT card is the upper-most Ethernet port available. The EtherCAT OUT port is the port just below the IN Port. See image for reference.

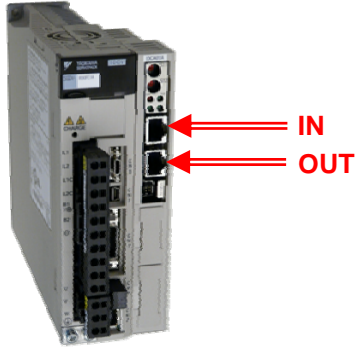

PART 2 Summary:

The SGDV Amplifier is now prepared to begin receiving EtherCAT communications and operate a motor.

PART III: Optional EtherCAT Settings

Note: For this part, communication with the amplifier must be established.

See Appendix Section 4: *Establishing EtherCAT Communications* for an example.

9. Distributed Clocks

The settings for the Distributed Clock on the amplifier can be modified.

See the below image for reference.

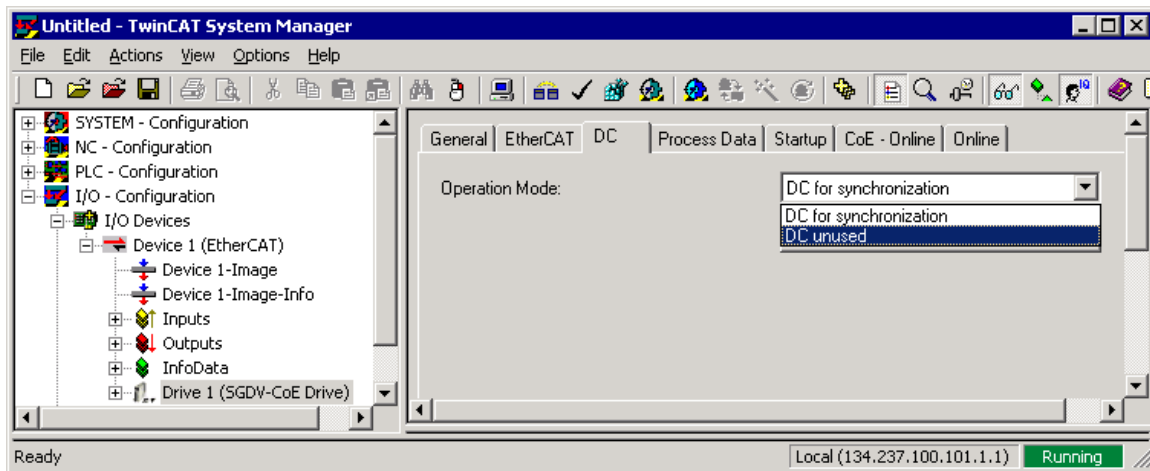

10. Manual Axis Addressing

Automatic axis addressing is enabled by default. If a condition requires manual axis addressing, changes to TwinCAT and the SGD V amplifier must be made. The manual axis address is also known as “secondary address” and “station alias”.

- a. Change made to the amplifier:

The hardware rotary DIP switches must be set to the desired station alias. The hardware rotary DIP switches are labeled S11 and S12 on the EtherCAT card. See the below image for reference.

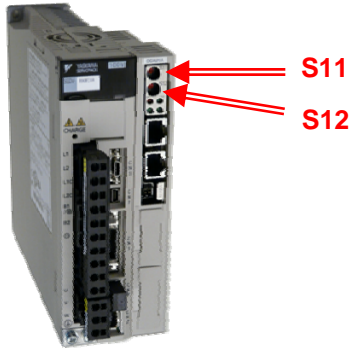

The equation to determine the station alias is:
 $\text{Station Alias} = (\text{S11 setting}) \times 16 + (\text{S12 setting})$

- b. Change made to TwinCAT:

The System Manager must be run in Admin mode in order to make the following changes (contact Beckhoff to request details about running TwinCAT in Admin mode).

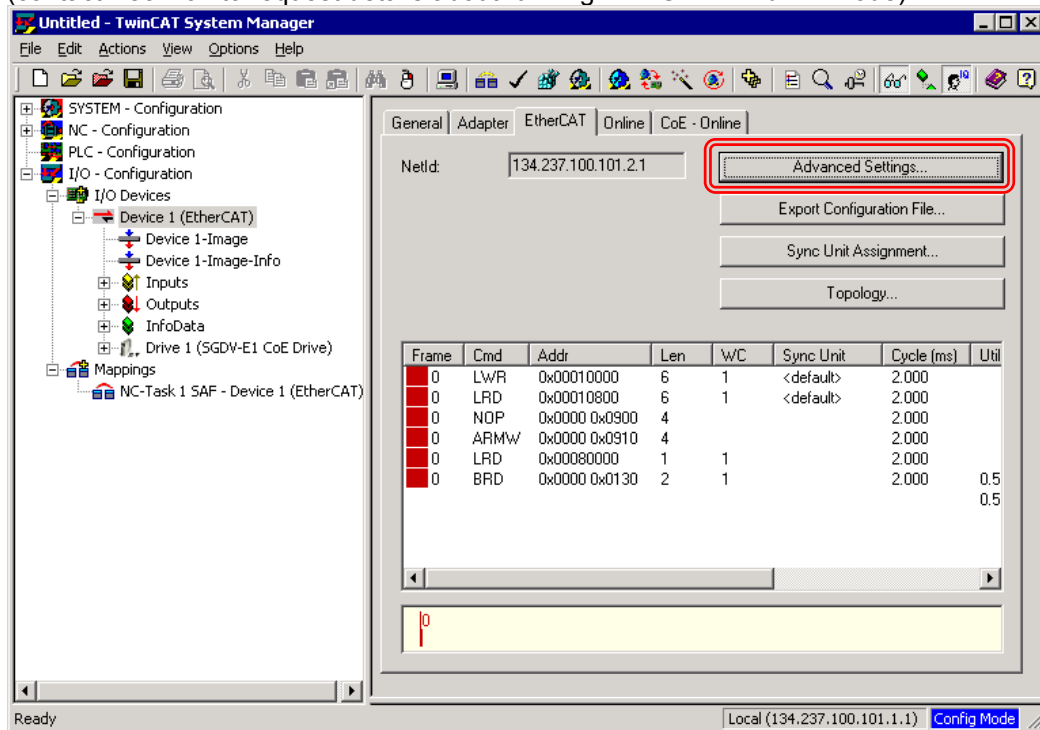

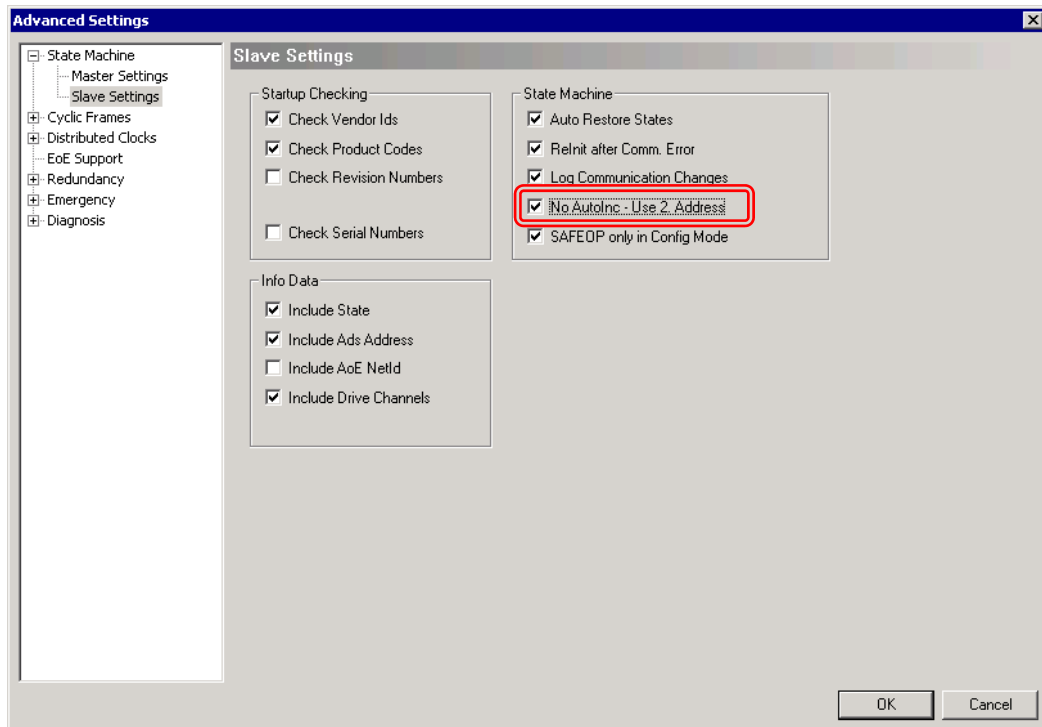

“No AutoInc – Use 2. Address” must have a solid check mark in order to use the second address of the nodes on the network.

A greyed check mark (or marking other than a check or blank), indicates that the second address of the nodes on the network will be used if specified by the device. Otherwise, an automatic address will be used.

APPENDIX

Section 1: Setting up the Ethernet Adapter for Real-Time Communications

1. Start TwinCAT:

From the desktop, right-click on the TwinCAT icon in the system tray
Choose System Manager.

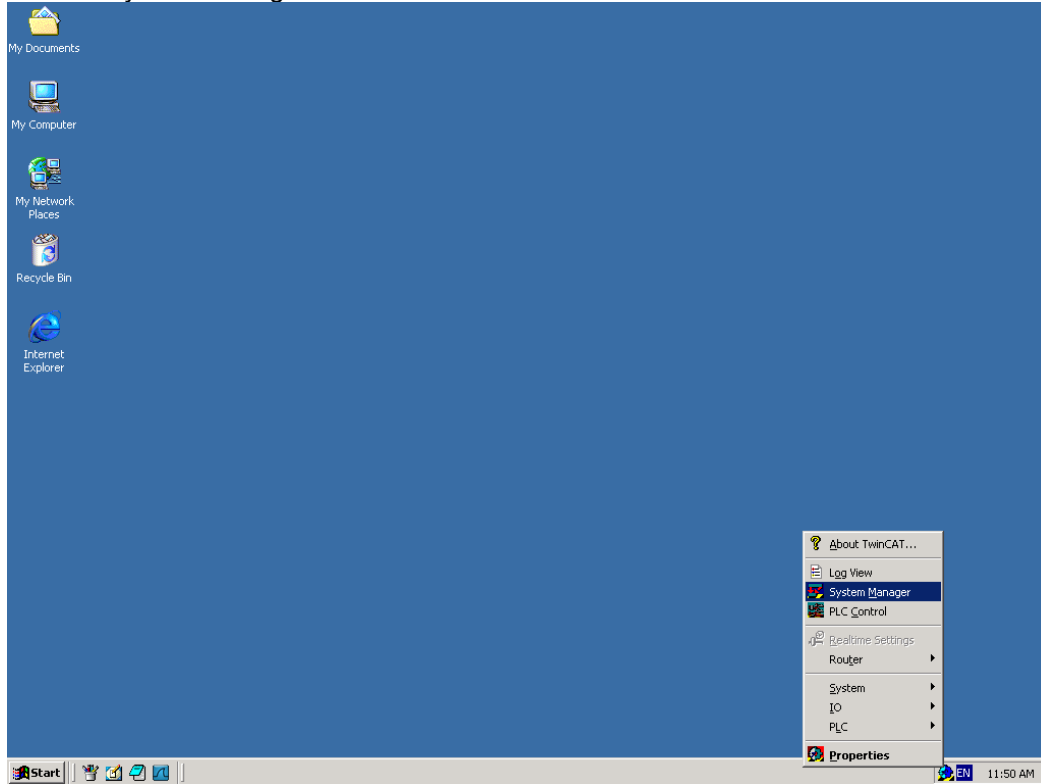

The icon should be blue. Otherwise, change TwinCAT to Config mode. This can be done by choosing the System menu choice instead of System Manager, then choosing the Config mode.

2. Show Real Time Ethernet Compatible Devices:
If this is the first time using TwinCAT on the system, the Ethernet device must be set to be used with TwinCAT.

From the Options menu, choose “Show Real Time Ethernet Compatible Devices...”

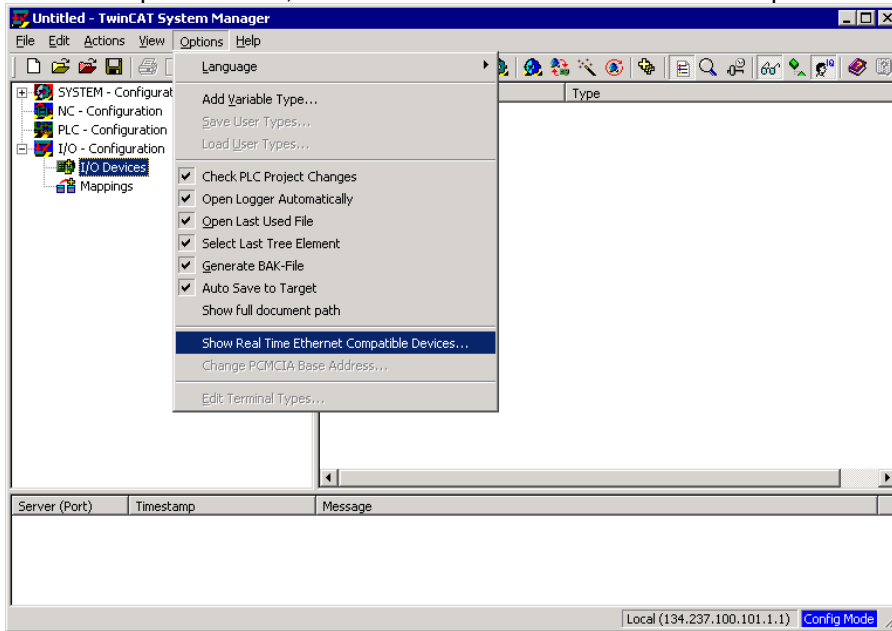

3. Enable the Ethernet port to be used with TwinCAT:
This screen shows that the Ethernet device is already installed to be used with TwinCAT. If running TwinCAT for the first time, the Ethernet device will appear under either Compatible or Incompatible devices.

Select the device and click the Install button.

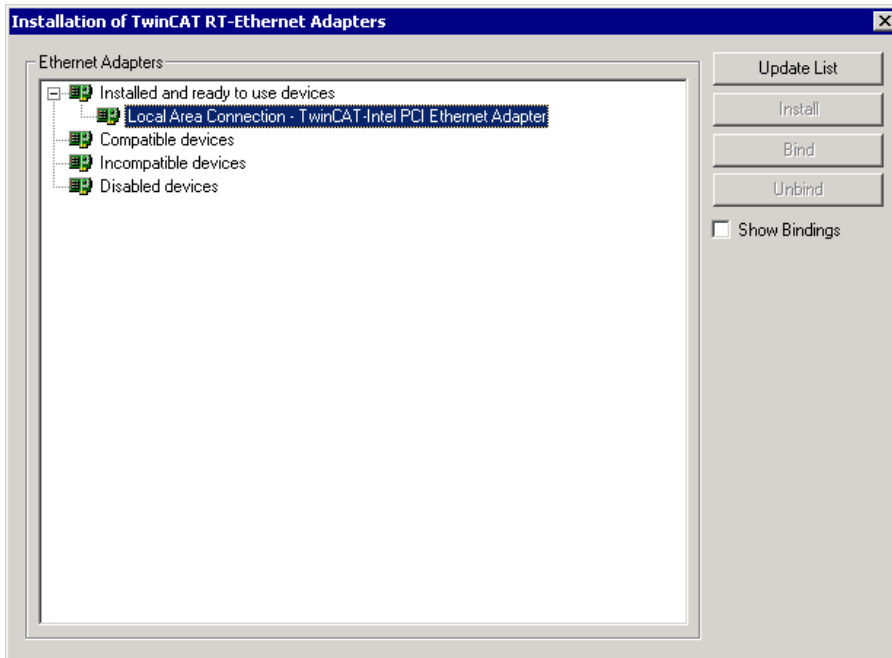

Note: Incompatible devices can be used with TwinCAT. Real-time commands might cause errors. Use Incompatible devices with caution.

APPENDIX

Section 2.1: Using a Digital Operator to Reset Absolute Encoder

The below information is from Section 4.5.4 of the Σ -V Series User's Manual Design and Maintenance Command Option Attachable Type (Manual number SIEP S800000 60A).

4.5.4 Absolute Encoder Setup (Initialization)

 CAUTION
<ul style="list-style-type: none"> If the absolute value encoder is initialized, rotational serial data will be set to 0 and the reference position of the machine system will change. If the machine is operated in this state, the machine may move unexpectedly and injury, death, or machine damage may result. Be sufficiently careful when initializing the absolute encoder.

Setting up the absolute encoder is necessary in the following cases.

- When starting the machine for the first time
- When an encoder backup error (A.810) is generated
- When an encoder checksum error (A.820) is generated
- To set the absolute encoder rotational serial data to 0













Setup the absolute encoder with Fn008.

(1) Precautions on Setup

- Setup the encoder when the servomotor power is OFF.
- The encoder backup error (A.810) and the encoder checksum error (A.820) cannot be reset by using the SERVOPACK alarm reset. Be sure to perform setup using Fn008.
- Any other alarms that monitor the inside of the encoder (A.8□□) should be canceled by turning OFF the power, then canceling the alarm.

(2) Procedure for Setup

Follow the steps below to setup the absolute encoder.

Step	Display after Operation	Keys	Description
1	<pre> BB —FUNCTION— Fn008:AlmHist Clr Fn008:Mturn Clr Fn009:Ref Adj Fn00A:Vel Adj </pre>	  	Press the  key and select Fn008.
2	<pre> BB Multiturn Clear PGCL1 </pre>		Press the  key to view the execution display of Fn008. Note: If the display is not switched and "NO_OP" is displayed in the status display, the Write Prohibited Setting (Fn010 = 0001) is set. Check the status and reset.
3	<pre> BB Multiturn Clear PGCL5 </pre>	 	Keep pressing the  Key until "PGCL1" is changed to "PGCL5."
4	<pre> DONE Multiturn Clear PGCL5 </pre>		Press the  Key to setup the absolute encoder. After completing the setup, "BB" in the status display changes to "DONE."
5	<pre> BB —FUNCTION— Fn008:AlmHist Clr Fn008:Mturn Clr Fn009:Ref Adj Fn00A:Vel Adj </pre>		Press the  Key to return to the display of the procedure 1.
6	Turn OFF the power and then turn it ON again to make the setting valid.		

APPENDIX

Section 2.2: Using SigmaWin+ to Reset Absolute Encoder

The below information is from Section 4.4.2 of the *SigmaWin+ Σ -V Component Online Manual* (The document is installed with SigmaWin+, with the file name SigmaWinFV.pdf).

4.4.2 Setting the Absolute Encoder

■ Initializing the Absolute Encoder

 WARNING
<p>The absolute encoder setup function resets the multi-turn counter and the encoder alarms for a connected serial absolute encoder.</p> <p>If the absolute encoder's multi-turn counter is reset to zero, the previously defined mechanical system will change to a different coordinate system.</p> <p>Operating the machine in this state is extremely dangerous. Failure to observe this warning may result in personal injury and/or damage to the machine. Be sure to reset the zero point for the mechanical system after the encoder has been successfully set up.</p>

Set up the absolute encoder in the following cases:

- At initial machine startup
- When an "Encoder Backup Alarm" has occurred
- When the SERVOPACK power has been turned off, and the encoder cable removed.

The absolute encoder can only be set up while the servo is off. Turn the power back on after the encoder has been successfully set up.

Set up the absolute encoder using the following procedure.

1. In the SigmaWin+ Σ -V component main window, click **Setup**, point to **Set Absolute Encoder** and click **Reset Absolute Encoder**. A warning message appears confirming if you want to continue the processing.

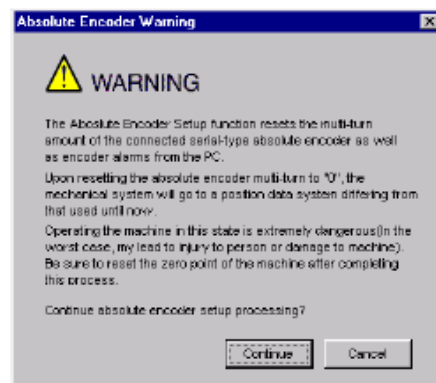



Click **Cancel** to return to the main window without resetting the absolute encoder.

2. Click **Continue**, and the Absolute encoder Setup box appears.



The Alarm Name box displays the code and name of the alarm that is occurring now.

Click the  button to display details concerning a specific alarm and its corrective measures.

Click the  button to return to the main window without resetting the absolute encoder.

3. Click **Execute setting**, and a verification message appears confirming if you want to continue although the coordinate system will change.



Click **Cancel** to return to the previous window without resetting the absolute encoder.

4. Click **Continue** to set up the encoder.

<If Setup is Unsuccessful>

If setting up is attempted with the servo ON, a reset conditions error occurs, and the processing is aborted.

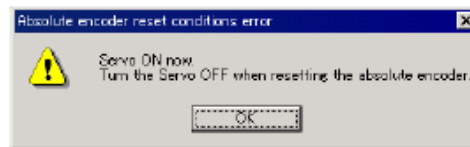

Click **OK** to return to the main window.

<If Setup Completes Normally>

If the encoder is set up successfully, a warning message will appear reminding you that the coordinate system has changed and must also be reset.



5. Click **OK** to return to the main window. Restart the servo, and perform an origin search for the upper-level controller.

APPENDIX

Section 2.3: Using CoE to Reset Absolute Encoder

The below information is from Section 8.5 Part (7) of the Σ -V Series User's Manual EtherCAT (CoE) Network Module (Manual number SIEP C720829 04A).

8.5 Manufacturer Specific Objects

(7) SERVOPACK Adjusting Command (2710h)

This object should be used for SERVOPACK adjusting services (e.g., Encoder setup, Multi-turn reset and so on). Writes the data into the Sub-Index 1 to start the command execution. Also, reads the Sub-Index 3 to accept the response. If the response is not available when reading Sub-Index 3, the first byte of the reply data could give information about the progress.

Index	Sub	Name	Data Type	Access	PDO Mapping	Value	EEPROM
2710h	0	Number of entries	USINT	RO	No	3	No
	1	Command	STRING [16]	RW	No	Byte 0 to n: Service Request Data A write access to the command data will execute the command	No
	2	Status	USINT	RO	No	0: last command completed, no errors, no reply 1: last command completed, no errors, reply there 2: last command completed, error, no reply 3: last command completed, error, reply there 255: command is executing	No
	3	Reply	STRING [16]	RO	No	Byte 0: as Subindex 2 Byte 1: unused 2 to n: Service Response Data	No

■ Command/Reply data format

Command data (Service Request data)	
Byte	Description
0	Reserved
1	Reserved
2	CCMD (Command code) 00: Read request 01: Write request
3	CSIZE (CDATA length in byte)
4 to 7	CADDRESS (Address)
8 to 15	CDATA (Writing data)

Reply data (Service Response data)	
Byte	Description
0	Status (As Subindex 2)
1	Reserved
2	RCMD (Echo back of CCMD)
3	RSIZE (R_DATA length in byte)
4 to 7	RADDRESS (Echo back of CADDRESS)
8 to 15	RDATA (Read data) /ERROCODE

■ Executable Adjustments

Adjustment	Request Code	Preparation before execution	Processing Time	Execution Conditions
Absolute encoder reset	1008H	Required	5 s max.	When using an incremental encoder, impossible to reset the encoder while the servo is ON.
Automatic offset adjustment of motor current detection signals	100EH	None	5 s max.	Adjustment is disabled: <ul style="list-style-type: none"> • While the main circuit power supply is OFF • While the servo is ON • While the servomotor is running
Multiturn limit setting	1013H	Required	5 s max.	When using an incremental encoder, the setting is disabled unless A.CC0 (Multiturn limit disagreement) occurs.

■ How to Send an Command for Adjustment

- Send the following data and set the request code of the adjustment to be executed.
CCMD = 0001H
CADDRESS = 2000H
CSIZE = 0002H
CDATA = Request code of the adjustment to be executed
When the slave station receives the command normally, status field will be returned to 1.
If an error occurs, carry out the operation in step 4 to abort execution.
- For adjustment that requires a preparation process, send the following data.
If the preparation before execution is not required, carry out the operation in step 3.
CCMD = 0001H
CADDRESS = 2001H
CSIZE = 0002H
CDATA = 0002H
When the slave station receives the command normally, status field will be returned to 1.
If an error occurs, carry out the operation in step 4 to abort execution.
- Send the following data to execute adjustment.
CCMD = 0001H
CADDRESS = 2001H
CSIZE = 0002H
CDATA = 0001H
When the slave station receives the command normally, status field will be returned to 1.
If an error occurs, carry out the operation in step 4 to abort execution.
- Send the following data to abort the execution.
CCMD = 0001H
CADDRESS = 2000H
CSIZE = 0002H
CDATA = 0000H
When the slave station receives the command normally, status field will be returned to 1.

Note: If no command can be received in 10 seconds after step1, adjustment operation will be automatically aborted.

APPENDIX

Section 3.1: Using a Digital Operator to Disable Overtravels

The below information provides resources to assist in changing Pn50A = 8xxx, and 50B=xxx8. The below information is from multiple sources:

- Section 4.2 Part (3) of the *Σ-V Series User's Manual Design and Maintenance Command Option Attachable Type* (Manual number SIEP S800000 60A).
- Section 2.2.3 Part (2) of the *Σ-V Series User's Manual Operation of Digital Operator* (Manual number SIEP S800000 55A).

4.2 Settings for Common Basic Functions



(3) Overtravel Function Setting

Parameters Pn50A and Pn50B can be set to enable or disable the overtravel function.



If the overtravel function is not used, no wiring for overtravel input signals will be required.

Parameter	Meaning	When Enabled	Classification
Pn50A	n.1□□□	After restart	Setup
	n.8□□□		
Pn50B	n.□□□2		
	n.□□□8		



- A parameter can be used to re-allocate input connector number for the P-OT and N-OT signals. Refer to 3.3.1 *Input Signal Allocations*.

-  and  Keys

When the cursor is on the left side (parameter number side), press

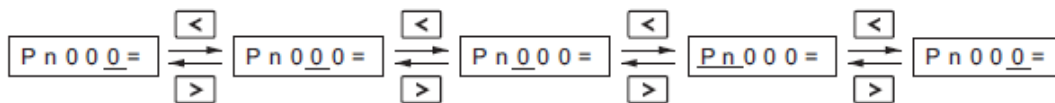
the  or  Key to move the cursor as follows.



When the cursor is on the right side (setting side), press the  or  Key to move the cursor as follows.

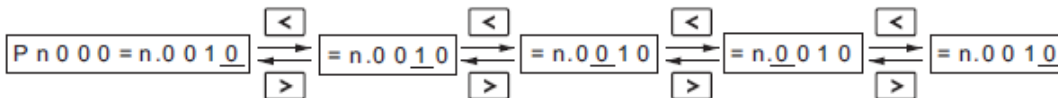

- **▲** and **▼** Keys

When the cursor is on “Un” or “Pn” on the left side (parameter number side), press the **▲** or **▼** Key to switch the monitor mode number “Un” to/from the parameter number “Pn.”



When the cursor is on a numeric character on the left side (parameter number side), press the **▲** or **▼** Key to change the parameter number and display respective setting.

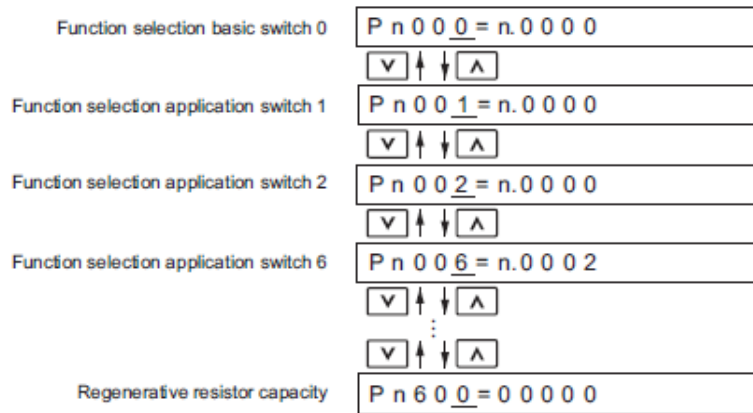

When the cursor is on the right side (the setting side), press the **▲** or **▼** Key to increase or decrease the numerical value of the cursor position.

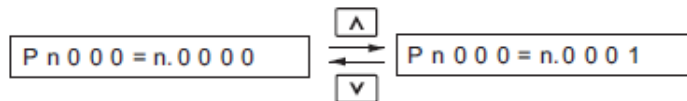

- **DATA** Key

Press this key to switch the cursor position between the parameter number and the setting.



After having changed the setting, press the **DATA** Key to write the new setting in the SERVOPACK.

APPENDIX

Section 3.2: Using SigmaWin+ to Disable Overtravels

The below information provides resources to assist in changing Pn50A = 8xxx, and 50B=xxx8. The below information is from multiple sources:

- Section 4.2 Part (3) of the *Σ-V Series User's Manual Design and Maintenance Command Option Attachable Type* (Manual number SIEP S800000 60A).
- Section 4.1.2 of the SigmaWin+ Σ-V Component Online Manual (The document is installed with SigmaWin+, with the file name SigmaWinFV.pdf).

4.2 Settings for Common Basic Functions

(3) Overtravel Function Setting

Parameters Pn50A and Pn50B can be set to enable or disable the overtravel function.

If the overtravel function is not used, no wiring for overtravel input signals will be required.

Parameter		Meaning	When Enabled	Classification
Pn50A	n.1□□□	Inputs the Forward Run Prohibited (P-OT) signal from CN1-7. [Factory setting]	After restart	Setup
	n.8□□□	Disables the Forward Run Prohibited (P-OT) signal. Allows constant forward rotation.		
Pn50B	n.□□□2	Inputs the Reverse Run Prohibited (N-OT) signal from CN1-8. [Factory setting]		
	n.□□□8	Disables the Reverse Run Prohibited (N-OT) signal. Allows constant reverse rotation.		

- A parameter can be used to re-allocate input connector number for the P-OT and N-OT signals. Refer to 3.3.1 *Input Signal Allocations*.

4.1.2 Editing Parameters Online

Parameters can be viewed or edited in the Online Parameter Editing window.



- Values edited in the Online Parameter Editing box are also immediately changed in the SERVOPACK.
- If the power to the SERVOPACK is turned off or the communication between the SERVOPACK and the SigmaWin+ is interrupted while editing parameters online, the edited values will not be saved in the SERVOPACK.

Edit parameters online using the following procedure.

1. In the SigmaWin+ Σ -V component main window, click **Parameters** and then click **Edit Online Parameters**. The Online Parameter Editing box appears. The previously saved parameter settings will be displayed.

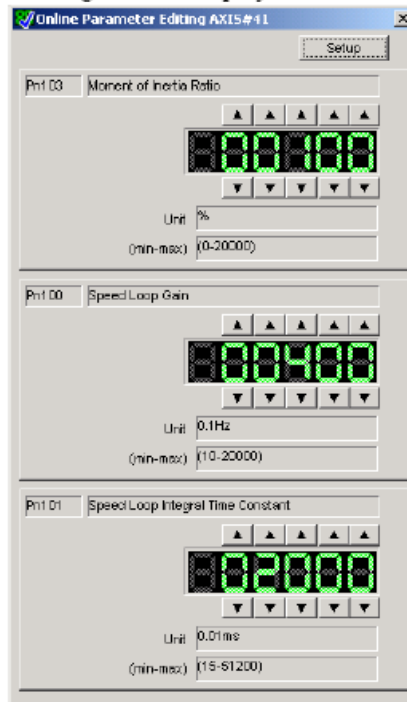

Online Parameter Editing Box

2. To change the values of the settings, click the setting arrows to raise or lower the value. If an upper or lower limit is displayed, make sure that the setting is within the limit. Modified values are also immediately changed in the SERVOPACK. Click **Setup** to view different parameters.

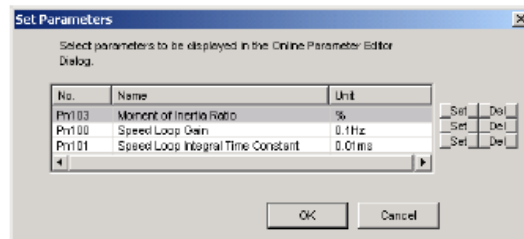

3. Click **Set** to view a parameter other than the "Moment of Inertia Ratio."

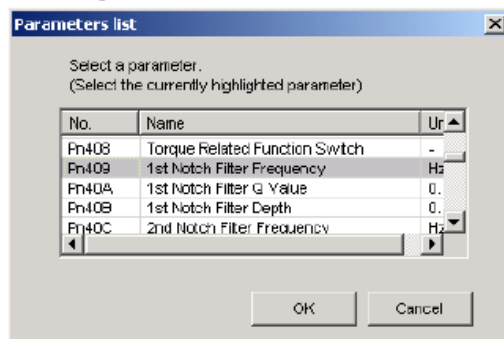

- Select the parameter to be edited, and click **OK**.

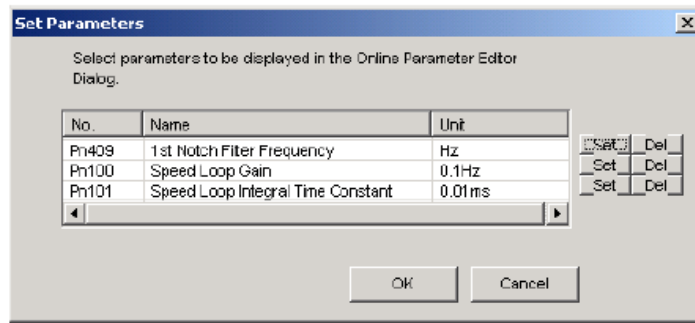

- If there are still parameters to be edited, click **Set** for a second or third time and set these in the same manner as the first parameter.

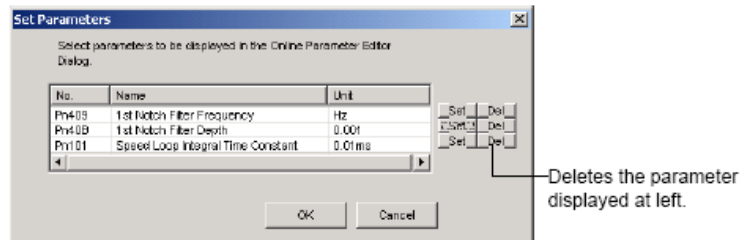

To view other parameters, click **Del** to delete the currently displayed parameter and then click **Set**.

- Click **OK** when parameter display is complete.

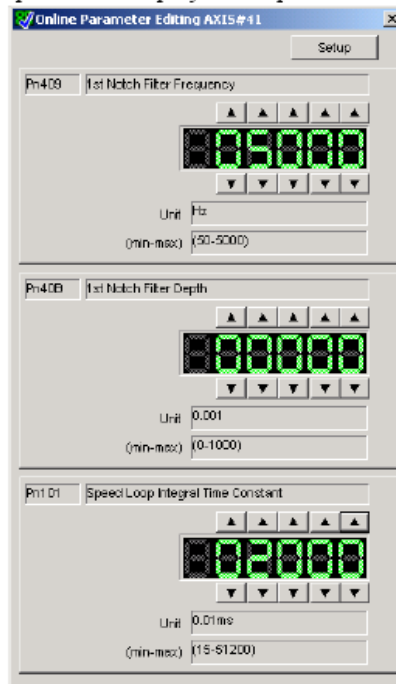

- To change the values of the settings, click the setting arrows to raise or lower the value. If an upper or lower limit is displayed, make sure that the setting is within the limit. Modified values are also immediately changed in the SERVOPACK.

Note: The drive must be reset (Fn030 or cycle power) for the settings in Pn50A and Pn50B to take effect.

APPENDIX

Section 3.3: Using CoE to Disable Overtravels

The below information provides resources to assist in changing Pn50A = 8xxx, and 50B=xxx8. The below information is from multiple sources:

- Section 4.2 Part (3) of the *Σ-V Series User's Manual Design and Maintenance Command Option Attachable Type* (Manual number SIEP S800000 60A).
- Section 8.5 Part (1) of the *Σ-V Series User's Manual EtherCAT (CoE) Network Module* (Manual number SIEP C720829 04A).
- Section 8.2 Part (5) of the *Σ-V Series User's Manual EtherCAT (CoE) Network Module* (Manual number SIEP C720829 04A).

4.2 Settings for Common Basic Functions

(3) Overtravel Function Setting

Parameters Pn50A and Pn50B can be set to enable or disable the overtravel function.

If the overtravel function is not used, no wiring for overtravel input signals will be required.

Parameter		Meaning	When Enabled	Classification
Pn50A	n.1□□□	Inputs the Forward Run Prohibited (P-OT) signal from CN1-7. [Factory setting]	After restart	Setup
	n.8□□□	Disables the Forward Run Prohibited (P-OT) signal. Allows constant forward rotation.		
Pn50B	n.□□□2	Inputs the Reverse Run Prohibited (N-OT) signal from CN1-8. [Factory setting]		
	n.□□□8	Disables the Reverse Run Prohibited (N-OT) signal. Allows constant reverse rotation.		

- A parameter can be used to re-allocate input connector number for the P-OT and N-OT signals. Refer to 3.3.1 *Input Signal Allocations*.

8.5 Manufacturer Specific Objects

(1) SERVOPACK Parameters (2000h-26FFh)

Object 2000h to 26FFh are mapped to SGD V SERVOPACK parameters (Pnxxx).

An object index 2xxxh is corresponding to a Pnxxx in SGD V SERVOPACK parameter. (e.g., Object 2100h is same as Pn100)

(5) Store Parameters (1010h)

With this object, the setting value of parameters can be stored in the non-volatile memory.

Index	Sub	Name	Data Type	Access	PDO Mapping	Value	EEPROM
1010h	0	Largest subindex supported	USINT	RO	No	4	No
	1	Save all parameters	UDINT	RW	No	0x00000000 to 0xFFFFFFFF (Default: 0x00000001)	No
	2	Save communication parameters	UDINT	RW	No	0x00000000 to 0xFFFFFFFF (Default: 0x00000001)	No
	3	Save application parameters	UDINT	RW	No	0x00000000 to 0xFFFFFFFF (Default: 0x00000001)	No
	4	Save manufacturer defined parameters	UDINT	RW	No	0x00000000 to 0xFFFFFFFF (Default: 0x00000001)	No

By reading data of an object entry, the SERVOPACK provides its capability to save parameters.

Bit	Value	Meaning
1	0	The SGD V SERVOPACK does not save parameters autonomously
0	0	The SGD V SERVOPACK does not save parameters on command
	1	The SGD V SERVOPACK saves parameters on command

In order to avoid storage of parameters by mistake, storage is only executed when a specific signature is written to the appropriate sub-index. The signature that shall be written is "save."

Signature	MSB				LSB			
ASCII	e	v	a	s				
hex	65h	76h	61h	73h				

By writing "save" to Sub-Index 1, all parameters are stored.

By writing "save" to Sub-Index 2, the communication parameters (Object 1000h to 1FFFh) are stored.

By writing "save" to Sub-Index 3, the application parameters (Object 27xxh and 6xxxh) are stored.

By writing "save" to Sub-Index 4, the SERVOPACK parameters (Object 2000h to 26FFh) are stored

- Note 1. If a wrong signature is written, the SGD V SERVOPACK refuses to store and responds with Abort SDO Transfer.
- If the storing parameters are executing, 0 will be returned by read this object.
 - Sub-Index 1 and Sub-Index 4 can be written only in Switch on Disabled state (Servo off state).
 - After the storing parameters by Sub-Index 1 or Sub-Index 4, power on reset or executing the parameter configuration (Object 2700h) is necessary to transit into the Operation Enabled state.

APPENDIX

Section 4: Establishing EtherCAT Communications

1. Start TwinCAT:

From the desktop, right-click on the TwinCAT icon in the system tray
Choose System Manager.

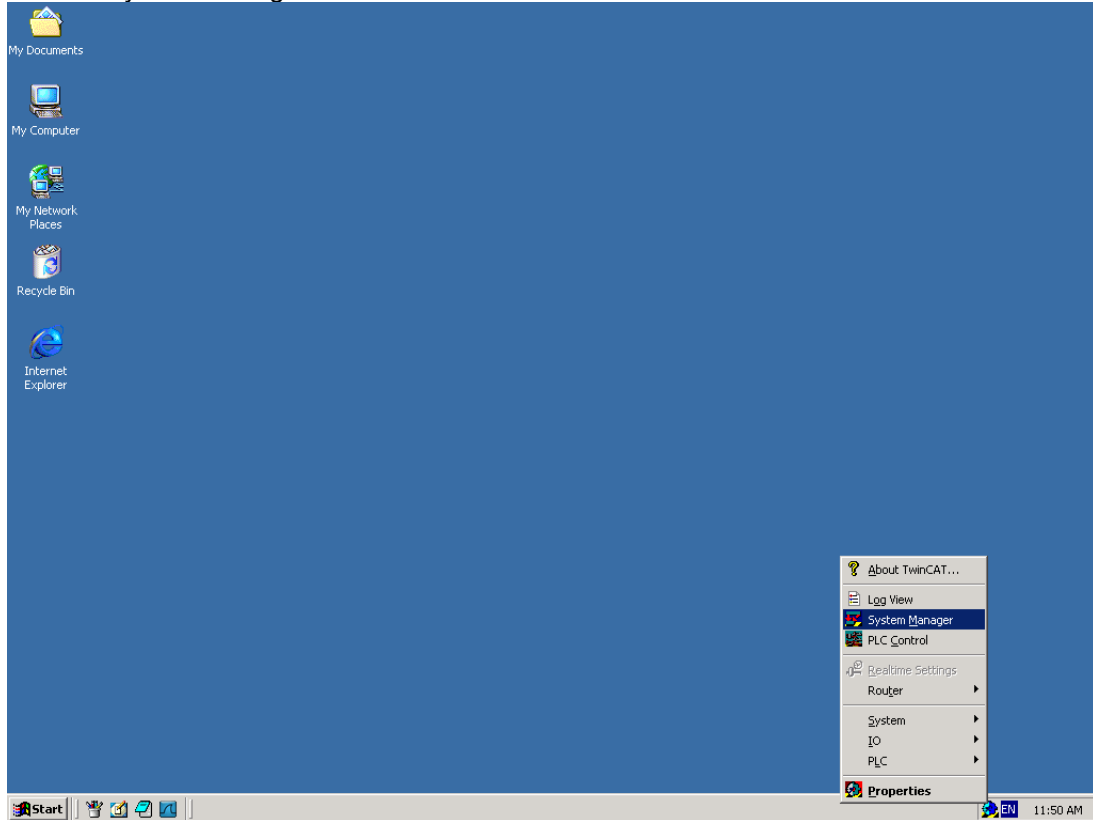

The icon should be blue. Otherwise, change TwinCAT to Config mode. This can be done by choosing the System menu choice instead of System Manager, then choosing the Config mode.

2. Add the Ethernet device:
Right-click I/O Devices.
Choose Scan Devices.

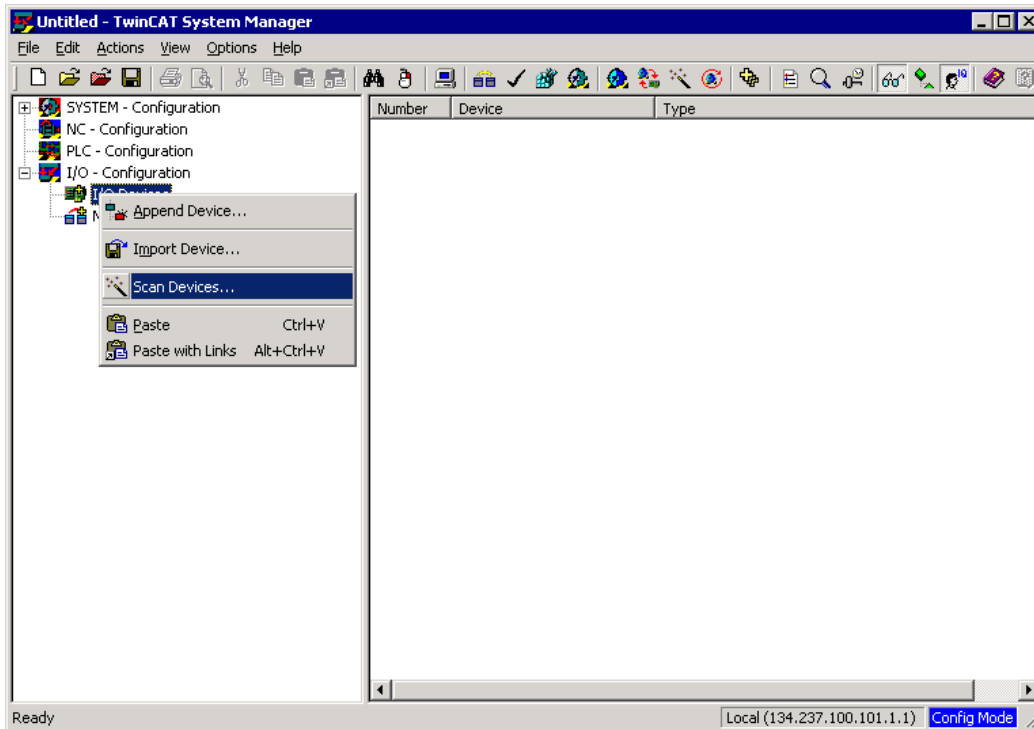

3. Click OK.

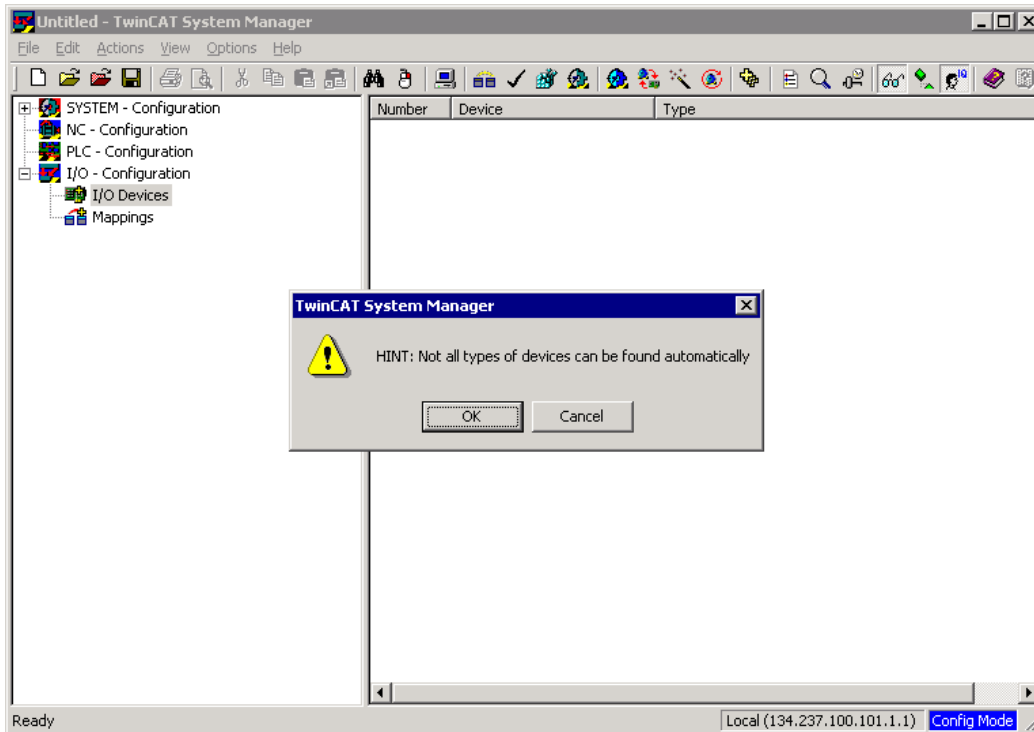

4. Deselect all but the Ethernet device.
Click OK.

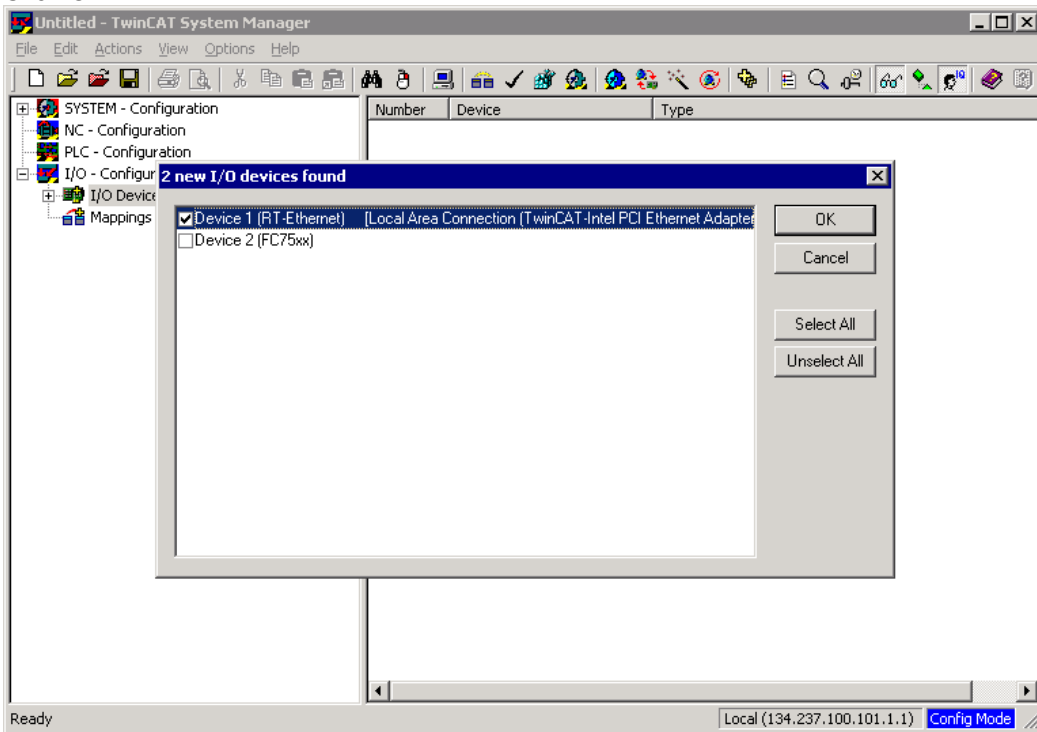

5. Add the devices connected to the Ethernet device:
Click Yes.

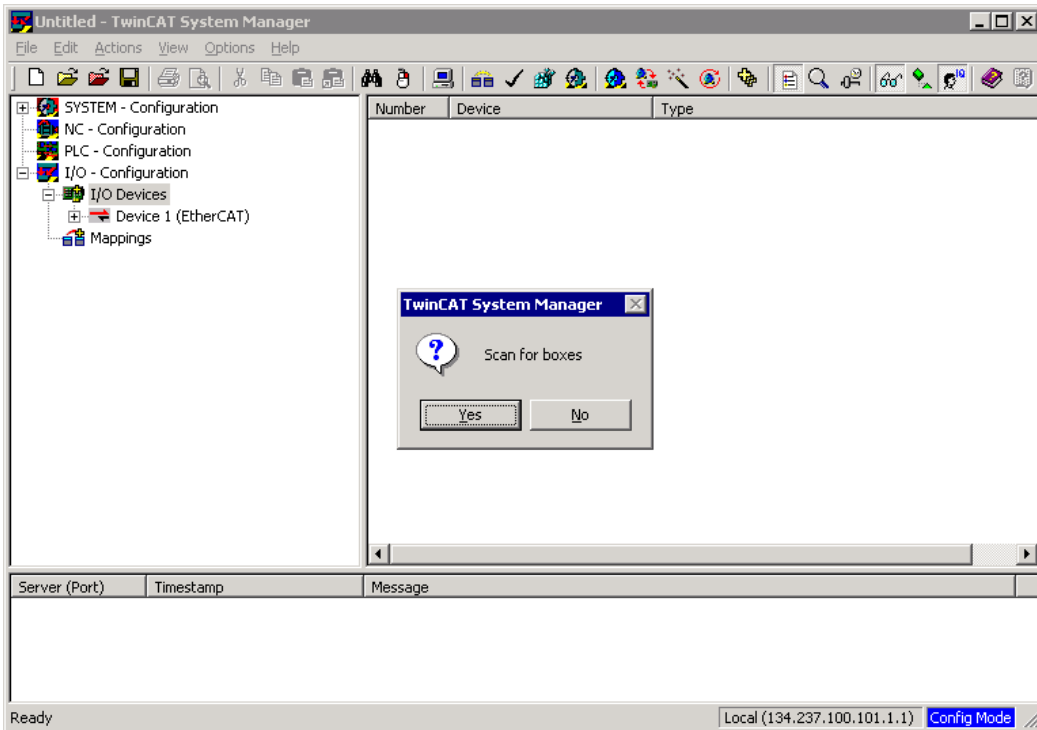

Boxes refer the devices that are on the Ethernet device. Most likely only TwinCAT compatible devices.

6. Click Yes.

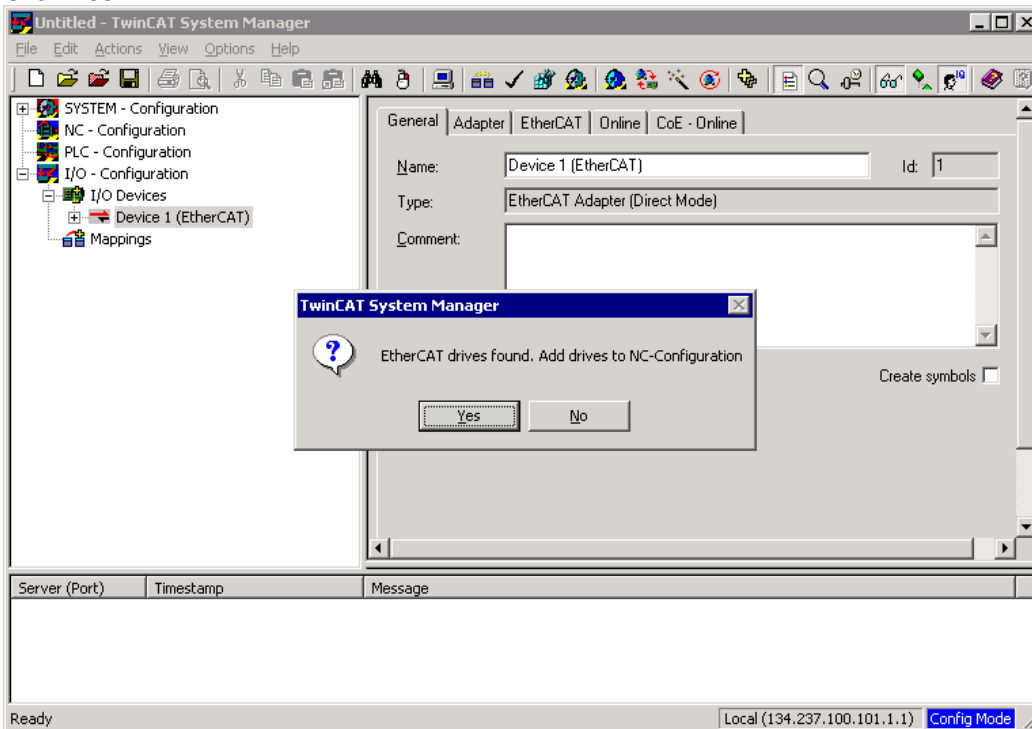

NC-Configuration is the numeric control section of TwinCAT. This allows control of basic drive functions via the TwinCAT GUI – which is the NC.

7. Click No.

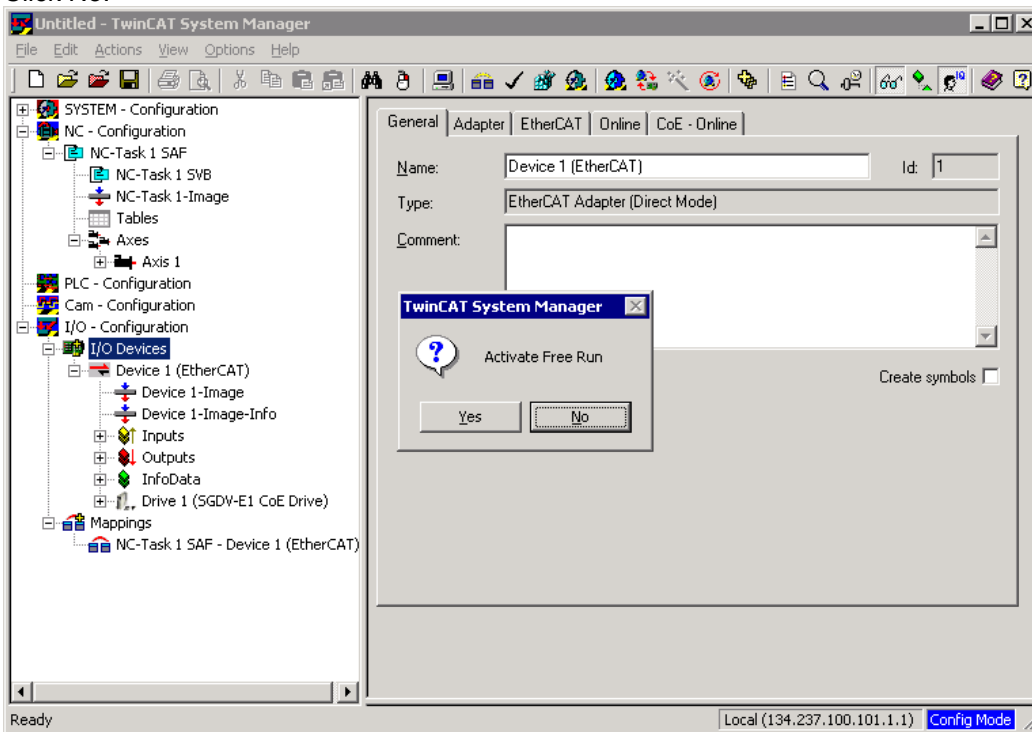

Free Run is a mode that is used to control I/O, which is not necessary for motion control. Clicking Yes will not cause any problems.

- Put the settings into effect:
From the Actions menu, choose “Activate Configuration...”

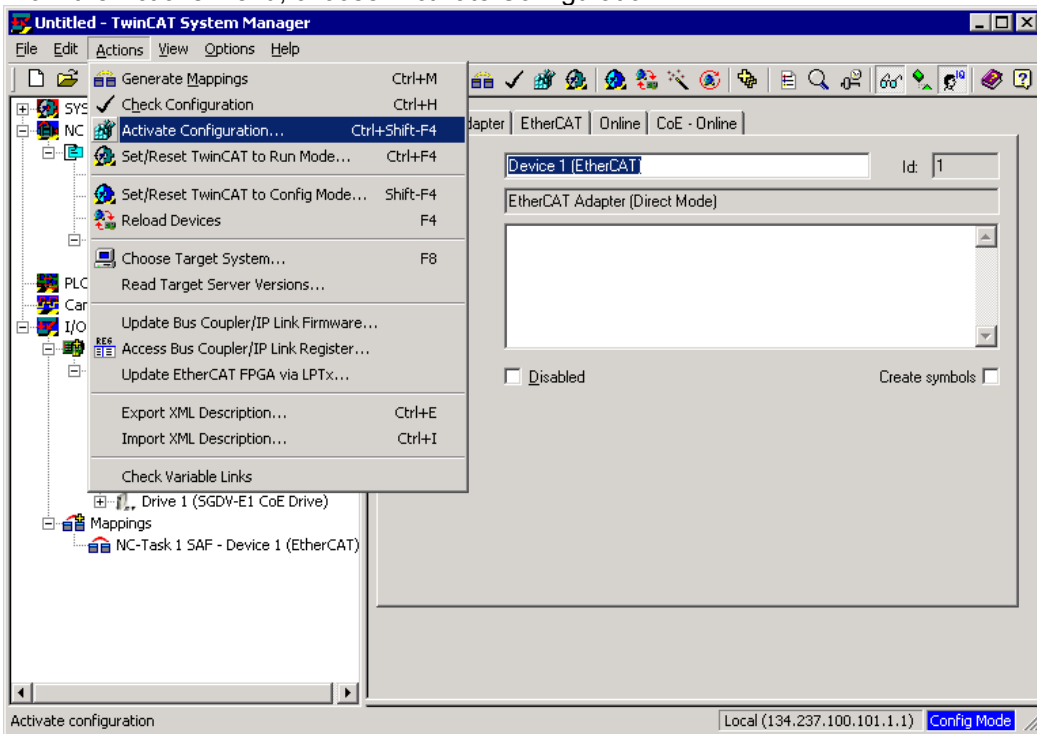

- Click OK.

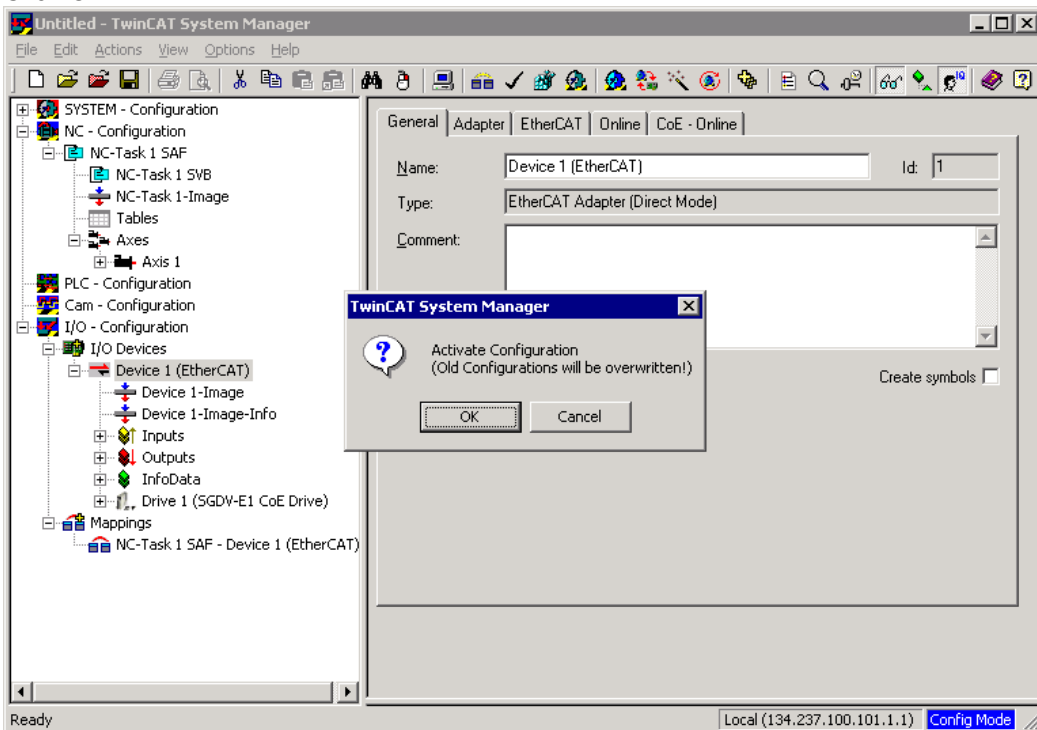

10. Start Real-Time EtherCAT communications:
Click OK.

