

# SERVO DRIVE SYSTEM COMPONENT

# f/V CONVERTERS

FOR SERVOMOTOR CONTROLLER *Servopack*™

TYPE JASP-FV010 ONE-AXIS PWB  
 TYPE JUSP-FV110 ONE-AXIS UNIT  
 TYPE JUSP-FV210 TWO-AXIS UNIT

The f/v converter type JASP-FV010 is used to gain speed feedback voltage, which is needed for Servopack, from an optical encoder output pulse. Mounting one JASP-FV010 on a unit makes one-axis unit type JUSP-FV110. Mounting two JASP-FV010 on a unit makes two-axis unit type JUSP-FV210.

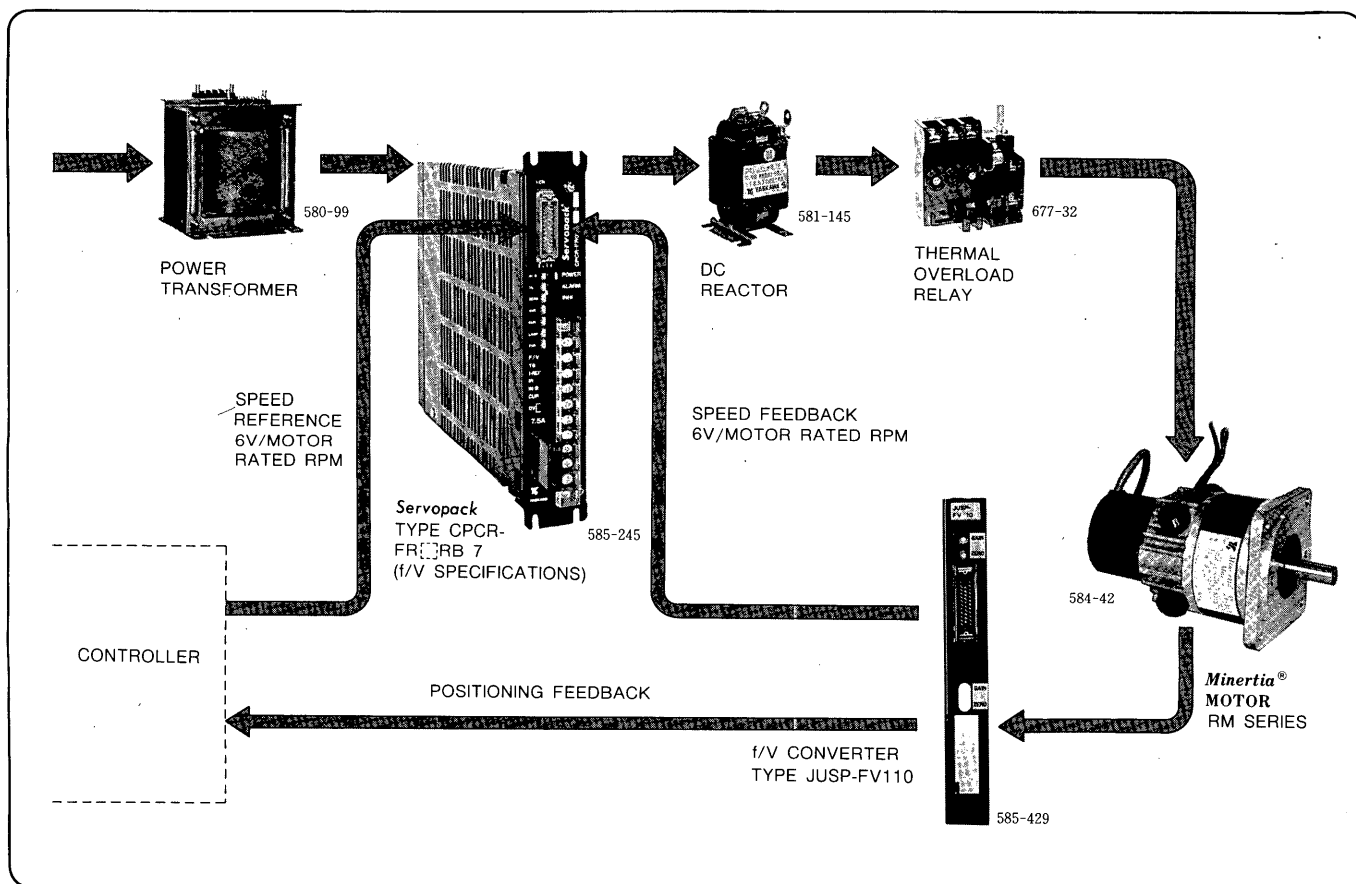
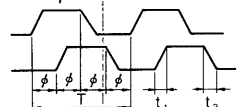
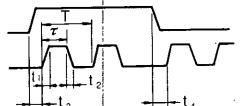
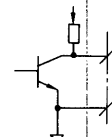
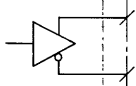
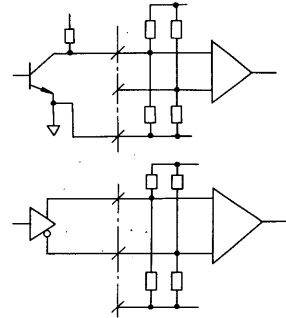



Fig. 1 Servodrive System Configuration



















# RATINGS AND SPECIFICATIONS

Table 1 Ratings and Specifications

Item	Specifications	Remarks		
Power Supply	+12V	+12V ±5%, 60mA	60mA + PG consumption at 12VPG	
	-12V	-12V ±5%, 20mA	—	
	+5V	+5V ±5%, 200mA	200mA + PG consumption at 5VPG	
Input	Max Input Frequency	2-phase pulse: 100kHz max  Sign+ pulse: 100kHz max 	Phase difference $\frac{\phi}{T}: 25 \pm 10\%$  $t_1, t_2 \leq 0.1 \mu s$ $t_3, t_4 > 5 \mu s$ $\tau \geq 5 \mu s$  $\frac{\tau}{T} \times 100 \leq 50\%$ (Duty cycle should be 50% or less at max frequency.)	
	Signal Level	5V/12V selectable	Input voltage is determined by the voltage being applied to terminal 17.	
	Signal Output Type	Open collector type  +5V or +12V  Line driver type 	Input circuit 	
f/V Output	Output Voltage*	±6V ±10%/10 to 100 kHz	Positive and negative outputs account for up to 5% of differences in the same frequency. Standard setting is ±6V/50kHz.	
	Load Resistance	10kΩ or more		
	Ripple	150mV or less		50mV or less at ±6V/50kHz
	Linearity	2%/FS max		At a standard setting
	Voltage and Temperature Regulation	5% max		Power supply: ±5% Temperature: 0 to 60°C (at a standard setting)
Pulse Output	Output Type	Open collector type	 SN 7416 N Max operational voltage: +12V	

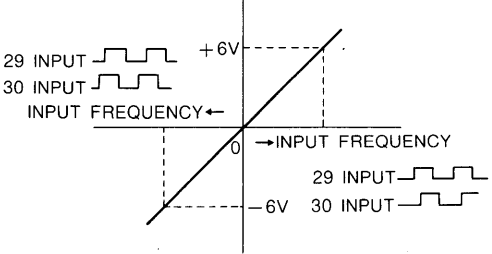
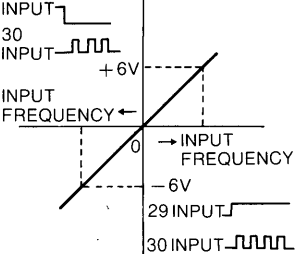
\*Output voltage is based on Table 2 Pulse Input/Output Voltage Characteristics. When output voltage is used for speed feedback, it should be set to 6V output at rated motor r/min and should be used in the range from -6V/ rated motor forward r/min to +6V/ rated motor reverse r/min.

Table 2 Pulse Input/Output Voltage Characteristics

	2-phase pulse input in 4-multiplier mode	2-phase pulse input in 2-multiplier mode	Sign + pulse input
<b>Mode Setting</b>	Input pulse frequency $\leq 50$ kHz SW-1  SW-2  SW-3  OFF ON	Input pulse frequency $> 50$ kHz SW-1  SW-2  SW-3  OFF ON	SW-1  SW-2  SW-3  OFF ON
<b>f/V Conversion Gain Setting</b>	$V = \frac{6(n+1)}{500} \times f_{PG}$	$V = \frac{6(n+1)}{1000} \times f_{PG}$	$V = \frac{6(n+1)}{2000} \times f_{PG}$
$f_{PG}$ : Input frequency (kHz) V: f/V output voltage (V) n: Setting of SW-4 to SW-9	$n = \text{SW-4} \times 1 + \text{SW-5} \times 2 + \text{SW-6} \times 4 + \text{SW-7} \times 8 + \text{SW-8} \times 16 + \text{SW-9} \times 32$ <p>SW-4  1                      SW-5  2                      SW-6  4                      SW-7  8                      SW-8  16                      SW-9  32</p> <p>SW-0: 1 at ON                      0 at OFF</p>		
<b>Input Pulse Phase/Output</b>	 <p>Phase A input increases and becomes plus output at phase.</p>		 <p>Phase A input becomes plus output at level H.</p>
<b>Filter Constant Setting</b>	SW-10 A  B SW-10 A  B SW-10 A  B		
Small time constant $\updownarrow$ Large time constant When 'n' becomes larger, output ripple becomes larger. Therefore the filter must be larger.			

# PARTS ARRANGEMENT ON f/V CONVERTER PCB

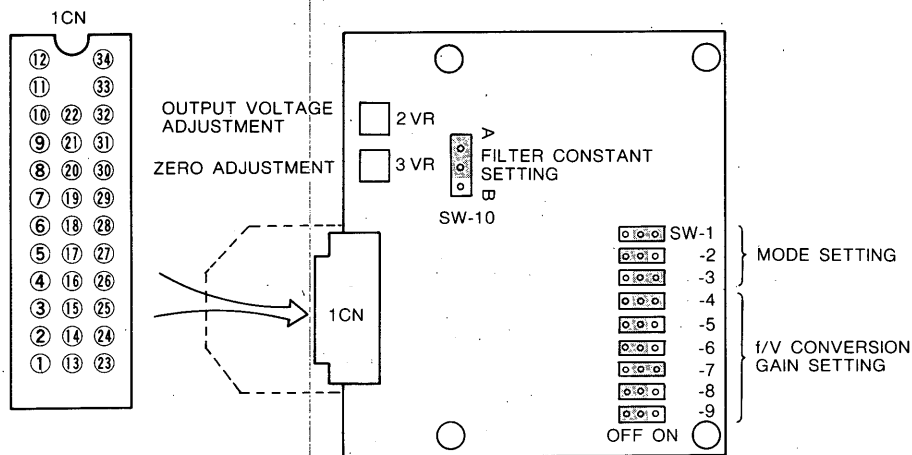



Fig. 2 Parts Arrangement on f/V Converter PCB

Table 3 Connector 1CN Specifications

Pin No. 1CN-	Signal Name	Functions
1 to 3	0V	Power supply 0V
4, 5	0V	PG supply-source 0V
15, 16, 27	+5V	Power supply +5V
23, 24	+12V	Power supply +12V
13, 14	-12V	Power supply -12V
26	+5V	Power supply terminal at 5VPG
25	+12V	Power supply terminal at 12VPG
17	+PG	Input level switching. Connect +5V at 5V input or +12V at 12V input.
29	A $\phi$	Phase A pulse input. Sign input at sign + pulse mode.
19	A $\phi$	Phase A pulse input. (Connect when output side is line driver.)
7	0V	0V of phase A pulse input
30	B $\phi$	Phase B pulse input. Pulse input at sign + pulse mode.
20	B $\phi$	Phase B pulse input. (Connect when output side is line driver.)
8	0V	0V of phase B pulse input
28	C $\phi$	Phase C pulse input
18	C $\phi$	Phase C pulse input. (Connect when output side is line driver.)
6	0V	0V of phase C pulse input
31	AX	Phase A pulse output (Open collector)
32	BX	Phase B pulse output (Open collector)
21	CX	Phase C pulse output (Open collector)
9, 10	0V	0V of signals AX, BX and CX
34	f/V	f/V conversion output
12	0V	0V of f/V conversion output
22	V <sub>c</sub>	Power supply input for power interlock, supplied from Servopack (8 to 12V).
33	GB	Power interlock signal output. Connect to base off terminal of Servopack.
11	0V	0V of power interlock signal. Connect to 0V of Servopack.

Table 4 6V Setting of f/V Output at Motor Rated Speed

Motor Rated Speed (r/min) PG Slit(p/rev)	1000	1500	1750	2000	2500	2800	3000	3600	4000
200							10.00 ×4 49	12.00 ×4 41	13.33 ×4 37
300				10.00 ×4 49	12.50 ×4 39	14.00 ×4 35	15.00 ×4 32	18.00 ×4 27	20.00 ×4 24
360			10.50 ×4 47	12.00 ×4 41	15.00 ×4 32	16.80 ×4 29	18.00 ×4 27	21.60 ×4 22	24.00 ×4 20
400	10.00 ×4 49	11.67 ×4 42	13.33 ×4 37	16.67 ×4 29	18.67 ×4 26	20.00 ×4 24	24.00 ×4 20	26.67 ×4 18	
500	12.50 ×4 39	14.58 ×4 33	16.67 ×4 29	20.83 ×4 23	23.33 ×4 20	25.00 ×4 19	30.00 ×4 16	33.33 ×4 14	
600	10.00 ×4 49	15.00 ×4 32	17.50 ×4 28	20.00 ×4 24	25.00 ×4 19	28.00 ×4 17	30.00 ×4 16	36.00 ×4 13	40.00 ×4 12
750	12.50 ×4 39	18.75 ×4 26	21.88 ×4 22	25.00 ×4 19	31.25 ×4 15	35.00 ×4 13	37.50 ×4 12	45.00 ×4 10	50.00 ×4 9
800	13.33 ×4 37	20.00 ×4 24	23.33 ×4 20	26.67 ×4 18	33.33 ×4 14	37.33 ×4 12	40.00 ×4 12	48.00 ×4 9	53.33 ×2 17
1000	16.67 ×4 29	25.00 ×4 19	29.17 ×4 16	33.33 ×4 14	41.67 ×4 11	46.67 ×4 10	50.00 ×4 9	60.00 ×2 16	66.67 ×2 14
2000	33.33 ×4 14	50.00 ×4 9	58.33 ×2 16	66.66 ×2 14	83.33 ×2 11	93.33 ×2 10	100.00 ×2 9		
2500	41.67 ×4 11	62.50 ×4 7	72.92 ×2 13	83.33 ×2 11					
3000	50.00 ×4 9	75.00 ×2 12	87.50 ×2 10	100.00 ×2 7					
5000	83.33 ×2 11								

 : Cannot be used due to large output ripple.  
 : Cannot be used as allowable input frequency is exceeded.

Note: Figures shown in each block;

Upper: Optical encoder output frequency at rated rpm (kHz)  
 Middle: Multiplier for f/V conversion mode  
 Lower: f/V conversion gain setting "n"

# APPLICATIONS

## WHEN USED FOR SPEED FEEDBACK

- Servopacks being combined should confirm to the specifications of f/V feedback. Speed feedback is set to 6 V at motor rated r/min.

Servopack type CPCR-FR RB7  
 f/V specifications

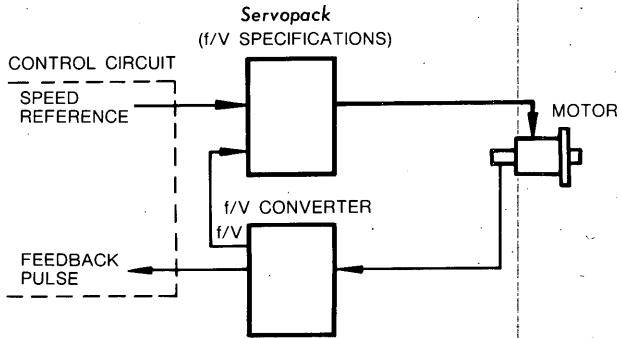

- Connect optical encoder signals so that the polarity of f/V converter output becomes minus at motor forward running.
- Since f/V converter type JASP-FV010 is set to 50kHz/6 V at the factory, the motor being used should output 6 V at its rated r/min. Proper adjustments should be made if necessary.

Use SW1 to SW9 for output adjustment. Do not tamper with the potentiometer (2VR) for output voltage adjustment.

- Select 2-phase pulse input "4-multiplier mode" when input frequency is 50kHz or less. Select 2-phase pulse input "2-multiplier mode" when input frequency is more than 50kHz.
- Output ripple becomes larger when an f/V converter is used in low speed or when f/V conversion gain is large (n becomes larger). In this case, make the filter constant larger.

Example 1: When a Minertia motor (3000 r/min) with 600-slit encoder is used

Since the encoder output pulse frequency ( $f_{PG}$ ) at motor rated r/min is:

$$f_{PG} = \frac{3000 \text{ r/min}}{60} \times 600 \text{ p/rev} = 30 \text{ kHz}$$

Where  $f_{PG} \leq 50 \text{ kHz}$ , use "4-multiplier mode."

$$V = \frac{6(n+1)}{500} f_{PG}$$

Therefore,

$$6(V) = \frac{6(n+1)}{500} \times 30(\text{kHz})$$

$$n = 15.67$$

Set to  $n = 16$  instead of  $n = 15.67$ .

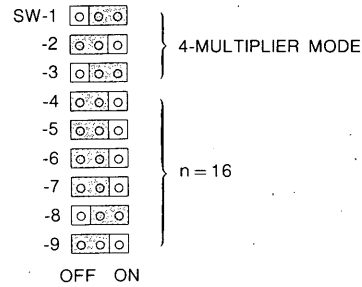

Example 2: When a Print motor type UGPMES-09 (4000 r/min) with 1000-slit encoder is used

Since the encoder output pulse frequency ( $f_{PG}$ ) at motor rated r/min is:

$$f_{PG} = \frac{4000 \text{ r/min}}{60} \times 1000 \text{ p/rev} = 66.66 \text{ kHz}$$

Where  $f_{PG} > 50 \text{ kHz}$ , use "2-multiplier mode."

$$V = \frac{6(n+1)}{1000} f_{PG}$$

Therefore,

$$6(V) = \frac{6(n+1)}{1000} \times 66.66(\text{kHz})$$

$$n = 14$$

Set to  $n = 14$ .

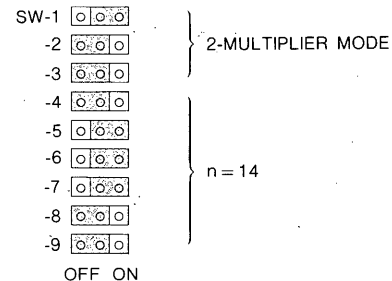

## WHEN USED FOR FEEDFORWARD

Connect f/V output so that it has the same polarity as the D/A output (plus output at motor forward running).

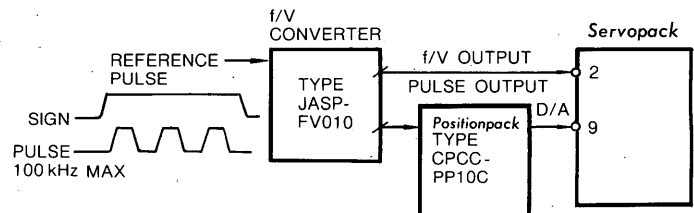

## WHEN USED AS A LEVEL CONVERTER

When f/V converter is not used,  $\pm 12 \text{ V}$  of power supply is not needed. Power supply for +PG(17) should be taken from the pulse generating unit.

## WHEN USED AS A SPEED MONITOR

Gain of a tachometer being connected to an f/V output should be  $\pm 5 \text{ V (200 } \mu\text{A) / FS}$ . Gain adjusting potentiometer (10 k $\Omega$ ) should be connected in series.

# CONNECTION DIAGRAM

## WHEN USED FOR SPEED FEEDBACK

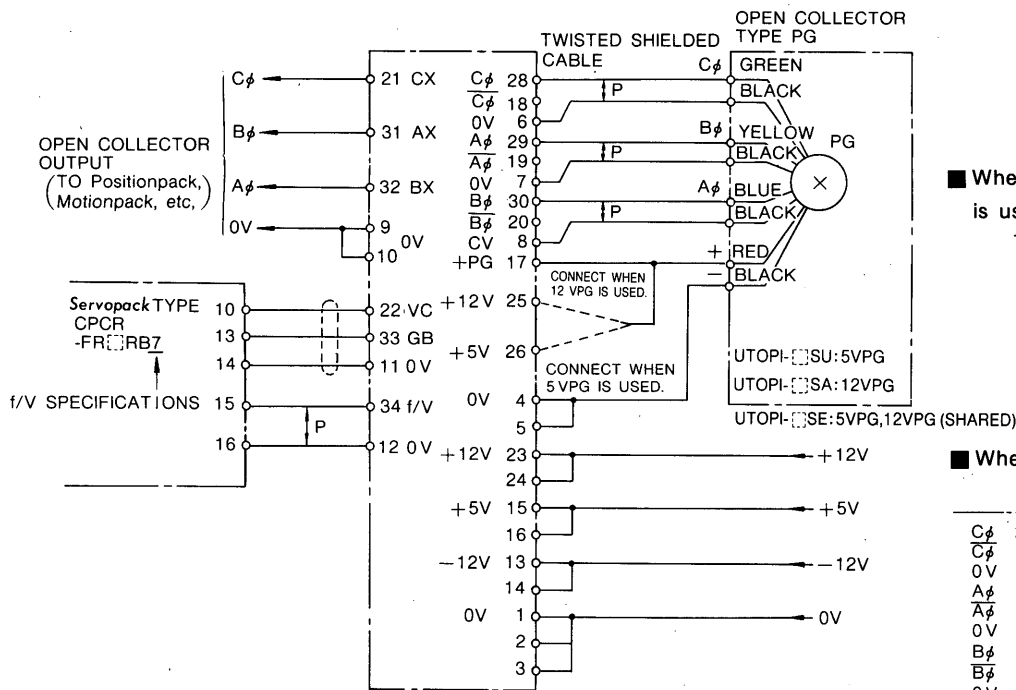

Note: Connect phase A and B outputs so that the polarity of f/V output becomes minus at motor forward running.

## When Servopack Type CPCR-FR□B97 is used

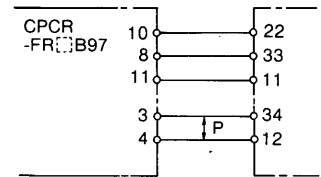

## When Servopack Type CPCR-MR□CY□ is used

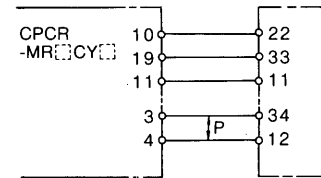

## When Line Driver Type PG is used

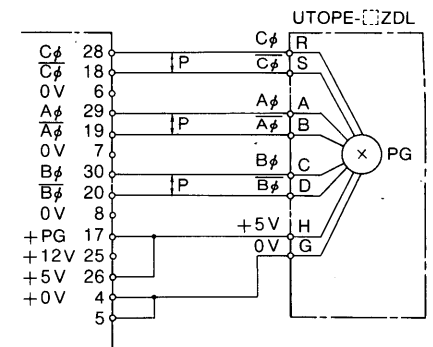

## WHEN USED FOR FEEDFORWARD

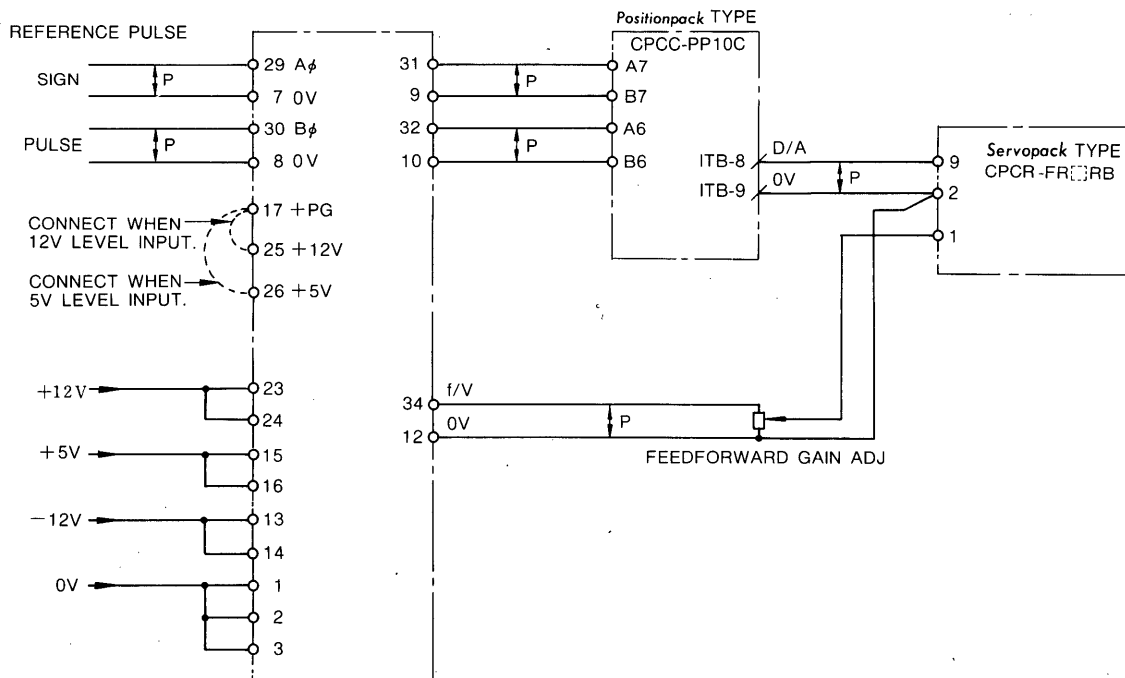

## WHEN USED AS A LEVEL CONVERTER

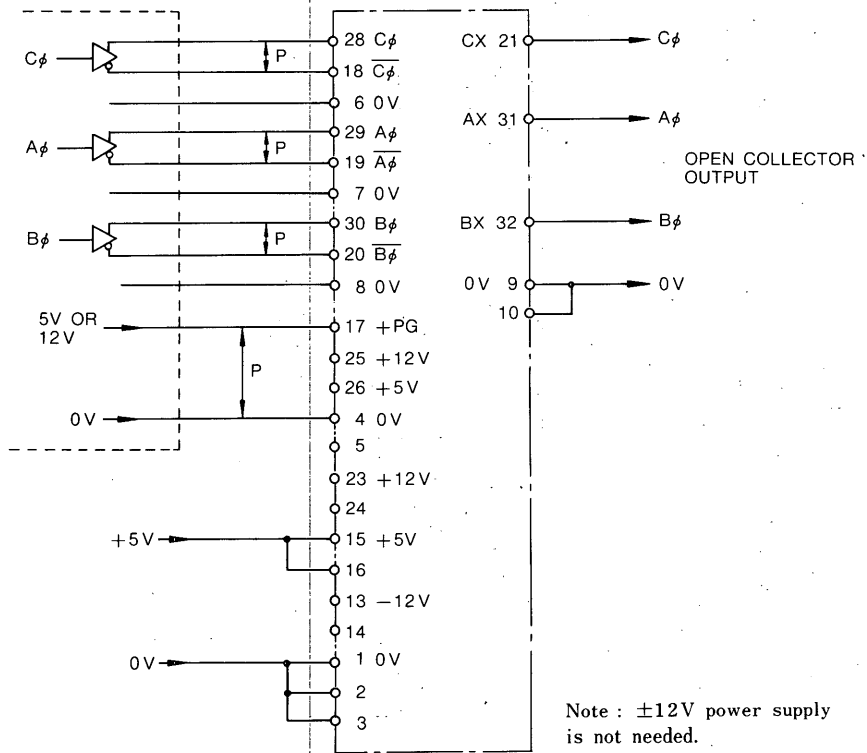

## WHEN USED AS A SPEED MONITOR OF AC SERVOMOTOR CONTROLLER *Servopack* TYPE CACR-SR

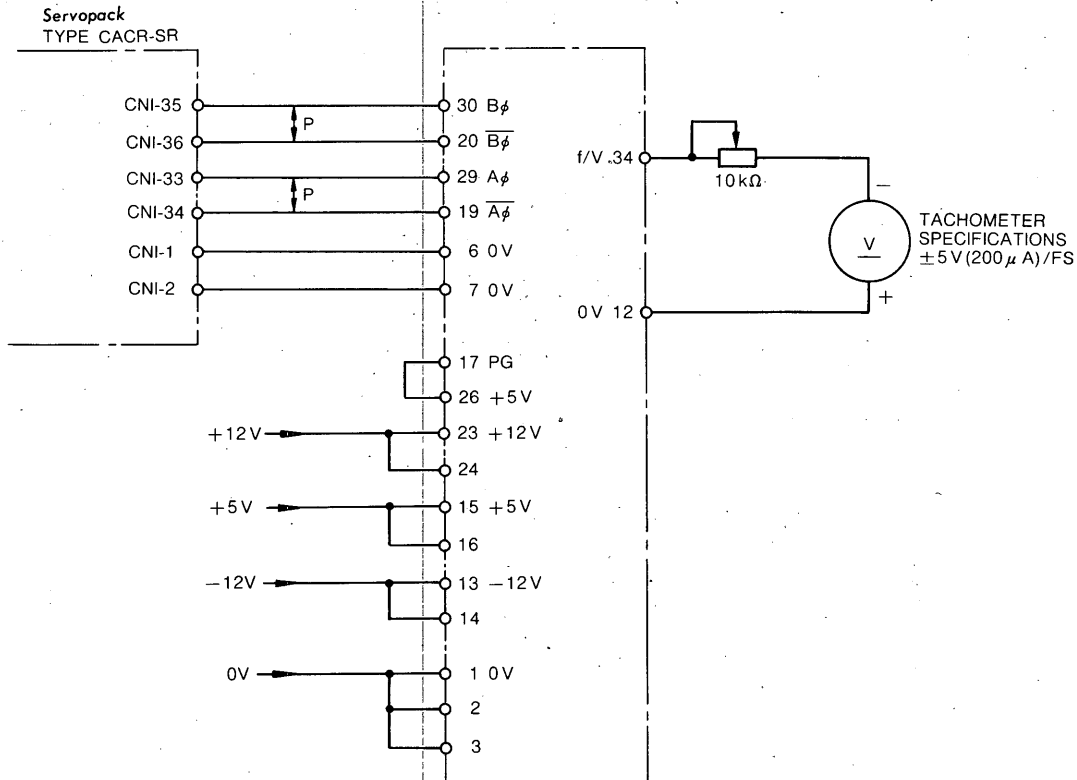

## CONNECTION BETWEEN PULSE OUTPUT FROM f/V CONVERTER AND DIGITAL CONTROLLER

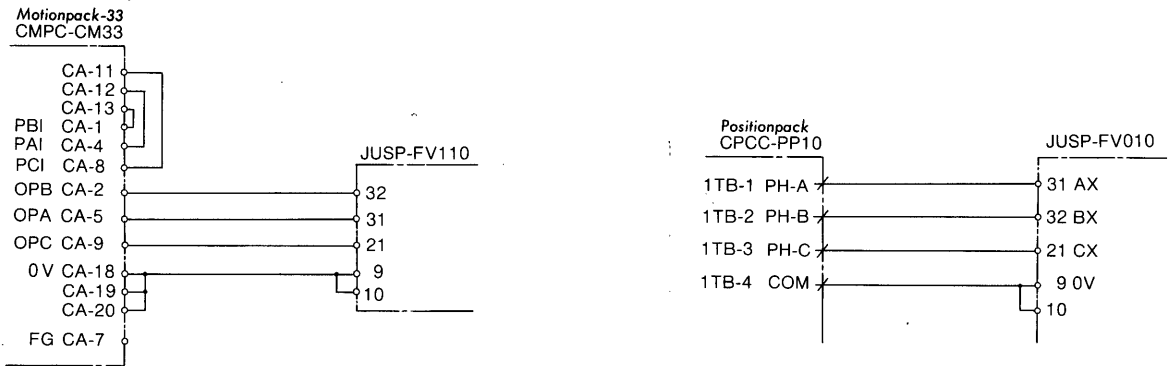

Note: When the pulse output from an f/V converter and a digital controller are connected, the following phase should be obtained at motor forward running.

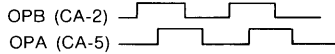

Note: When the pulse output from an f/V converter and a digital controller are connected, the following phase should be obtained at motor forward running.

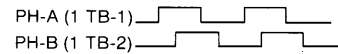

## PRECAUTIONS FOR APPLICATION

- An f/V converter is preset as follows as standard:

Input: 50 kHz, Output: 6 V

Adjust the setting depending on the motor being used. That is, set the f/V converter so that it outputs 6 V when the motor rotates at rated speed.

- Output of  $6 V \pm 5\%$  will be given (due to a digital setting) when the motor rotates at rated speed. If the output voltage difference is too large, change the setting (n).
- When an f/V converter is used for speed feedback, connect the encoder signal so that the polarity of f/V output becomes minus at motor forward running.

### NOTE

Direction of the motor rotation and the output phase of the encoder depend on the motor being used. Check them by comparing with drawings of the motor.

- Do not connect the input circuit of an f/V converter and other circuits in parallel. Connect the encoder directly to an f/V converter. Connections to other circuits should be made by wiring from the open collector output of the f/V converter.

- Use twisted shielded cables for the wiring between the encoder and the f/V converter. Keep sufficient distance from power cables to avoid interference.
- Use twisted cables for the wiring of pulse outputs and f/V outputs. (If the wiring tends to be too long, use twisted shielded cables.) Wiring distance should be shortened as much as possible.

- Install an f/V converter as close to a Servopack as possible. Fig. 3 shows an example of an installation.

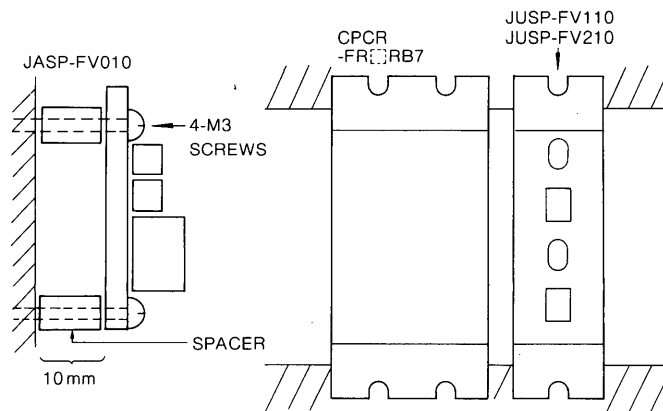
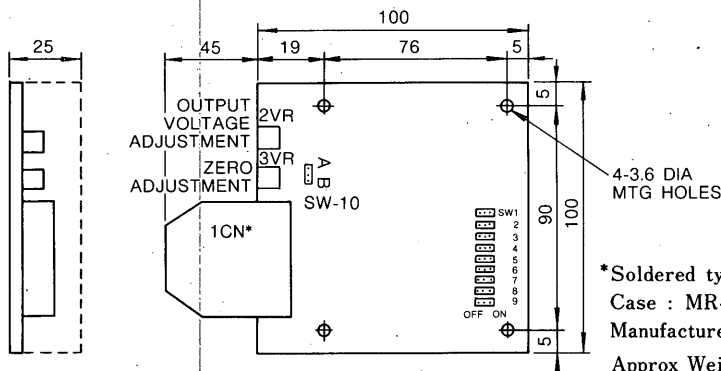

Fig. 3 Mounting of f/V Converter

**DIMENSIONS** in mm

TYPE JASP-FV010



\*Soldered type receptacle : MR-34F  
Case : MR-34L  
Manufacturer : Honda Tsushin Co., Ltd.  
Approx Weight 100g

TYPES JUSP-FV110, -FV210

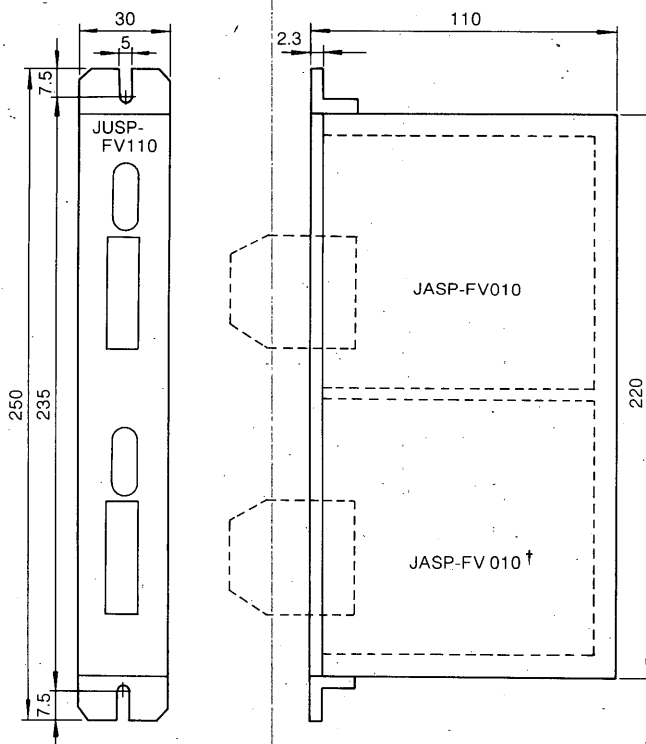

Approx Weight JUSP-FV110 : 500g  
JUSP-FV210 : 600g

† Furnished only for type JUSP-FV210.



A Better Tomorrow for Industry through Automation

**YASKAWA Electric Mfg. Co., Ltd.**

**TOKYO OFFICE** Ohtemachi Bldg., 1-6-1 Ohtemachi, Chiyoda-ku, Tokyo, 100 Japan  
Phone (03) 3284-9111, -9145 Telex YASKAWA J33530 Fax (03) 3284-9034

**SEOUL OFFICE** Seoul Center Bldg., 91-1 So Kong-Dong, Chung-Ku, Seoul, Korea.  
Phone (02) 776-7844 Fax (02) 753-2639

**SINGAPORE OFFICE** CPF Bldg., 79 Robinson Road No. 24-03, Singapore 0106  
Phone 2217530 Telex (87) 24890 YASKAWA RS Fax (65) 224-5854

**TAIPEI OFFICE** Union Commercial Bldg., 137, Nanking East Road, Sec. 2, Taipei, Taiwan  
Phone (02) 507-7065, -7732 Fax (02) 506-3837

**YASKAWA ELECTRIC AMERICA, INC. : SUBSIDIARY**

**Chicago Office (Head Office)** 3160 MacArthur Blvd., Northbrook, Illinois 60062-1917, U.S.A.  
Phone (708) 291-2340, 291-2348 Telex (230) 270197 YSKW YSNC NBRK Fax (708) 498-2430, 480-9731

**Los Angeles Office** 7341 Lincoln Way, Garden Grove, California 92641, U.S.A.  
Phone (714) 894-5911 Telex (230) 678396 YASKAWAUS TSTN Fax (714) 894-3258

**New Jersey Office** 30 Two Bridges Road, Fairfield, New Jersey 07006, U.S.A.  
Phone (201) 575-5940 Fax (201) 575-5947

**YASKAWA ELECTRIC EUROPE GmbH : SUBSIDIARY**  
Niederh ochst adter Stra e 71-73, W 6242 Kronberg-Oberh ochstadt, Germany  
Phone (06173) 640071, 640072, 640073 Telex 415660 YASE D Fax (06173) 68421

**YASKAWA EL TRICO DO BRASIL COM RCIO LTDA.: SUBSIDIARY**  
Av. Brig. F aria Lima, 1664-cj, 721/724, Pinheiros, S o Paulo-SP, Brasil CEP-01452  
Phone (011) 813-3933, 813-3694 Telex (011) 82869 YSKW BR Fax (011) 815-8795

Due to ongoing product modification/improvement, data subject to change without notice.