

Connection Diagram, Single-phase

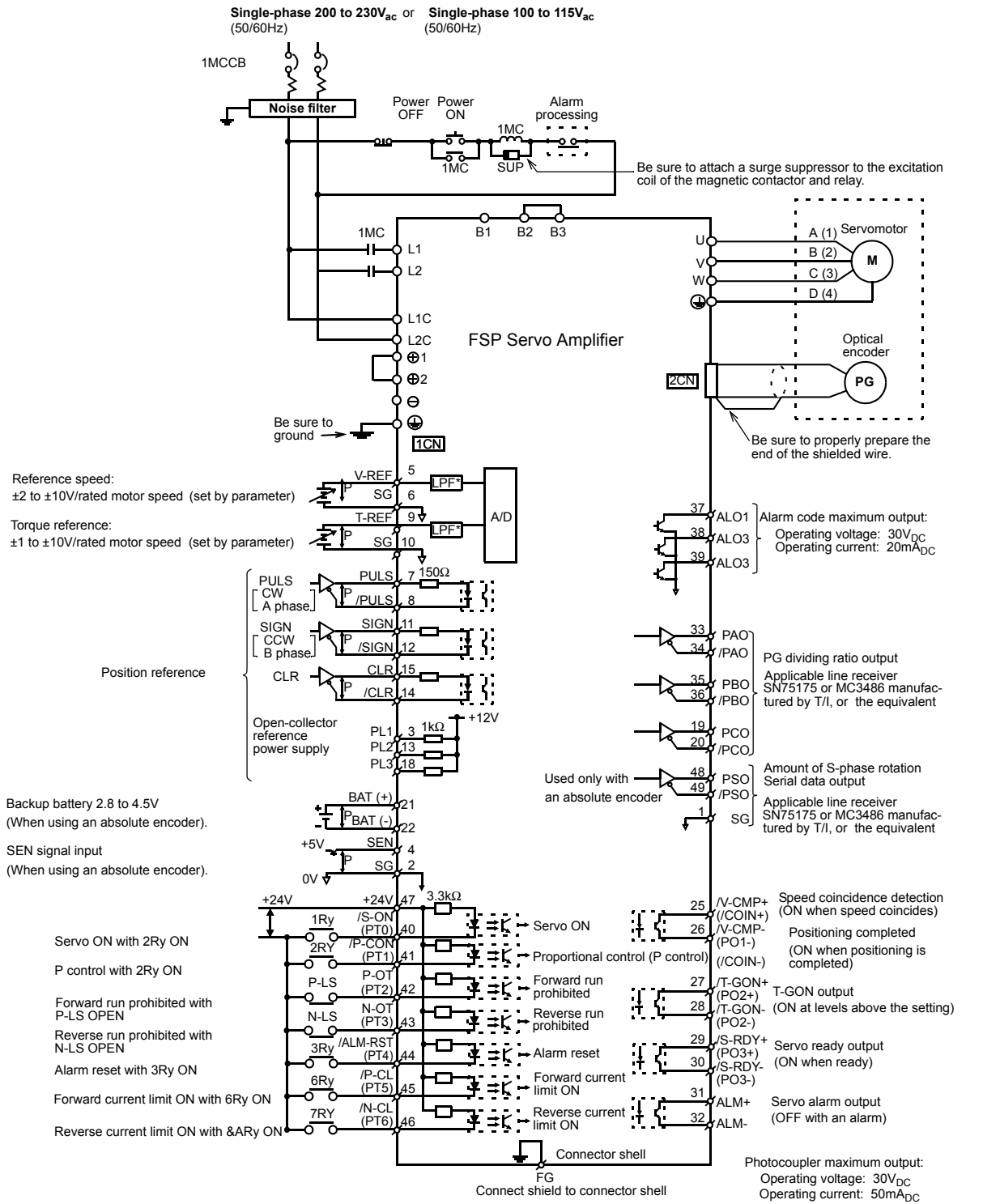

*The time constant for the primary filter is 47μs

┆P: Indicates twisted wire pairs.

PI1 = PGMINP1

PO1+ = PGMOUT1+

Connection Diagram, Three-phase

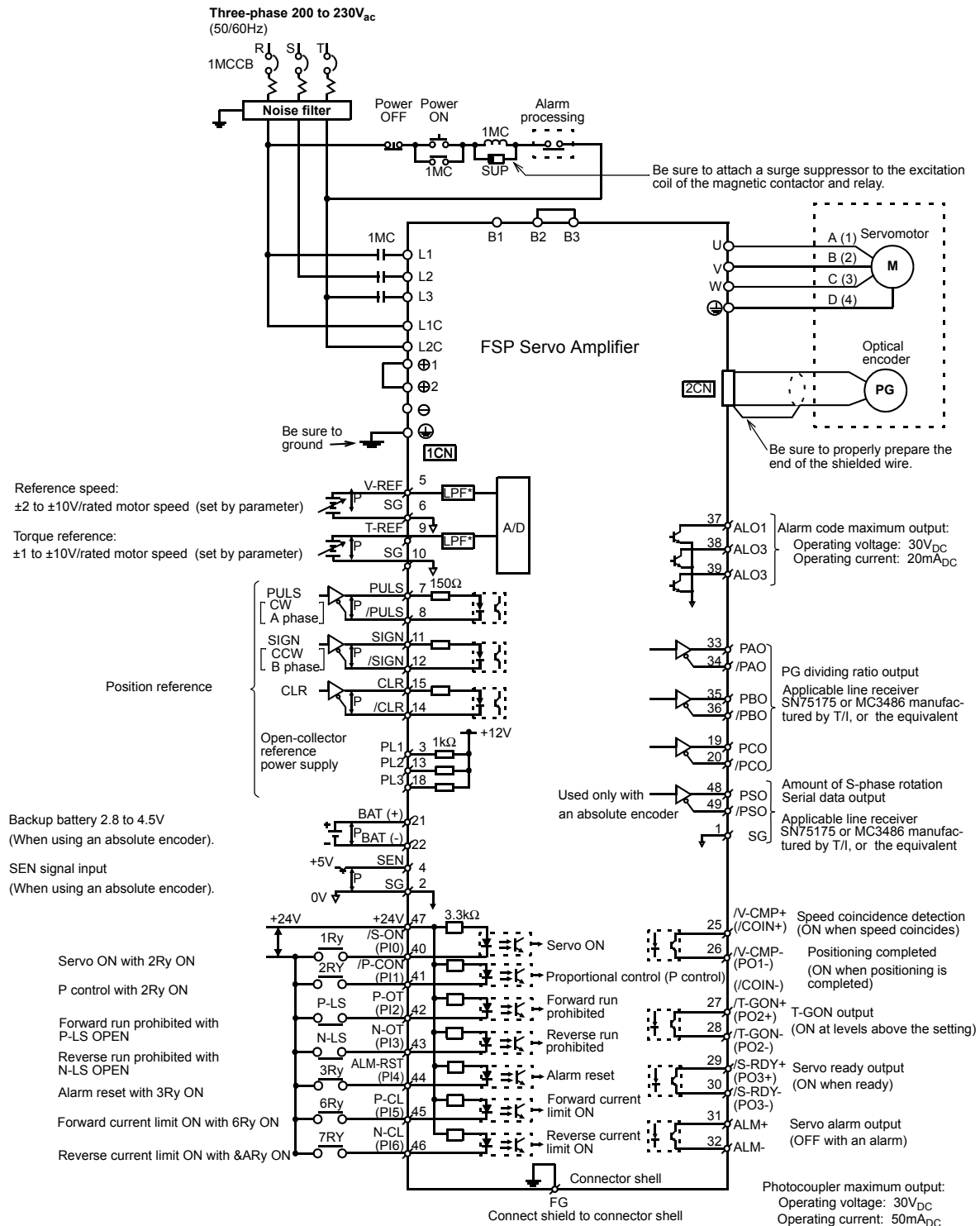

*The time constant for the primary filter is 47μs

⊕P: Indicates twisted wire pairs.

Connection Diagram, Three-phase

- 400V, 500W to 5kW Models

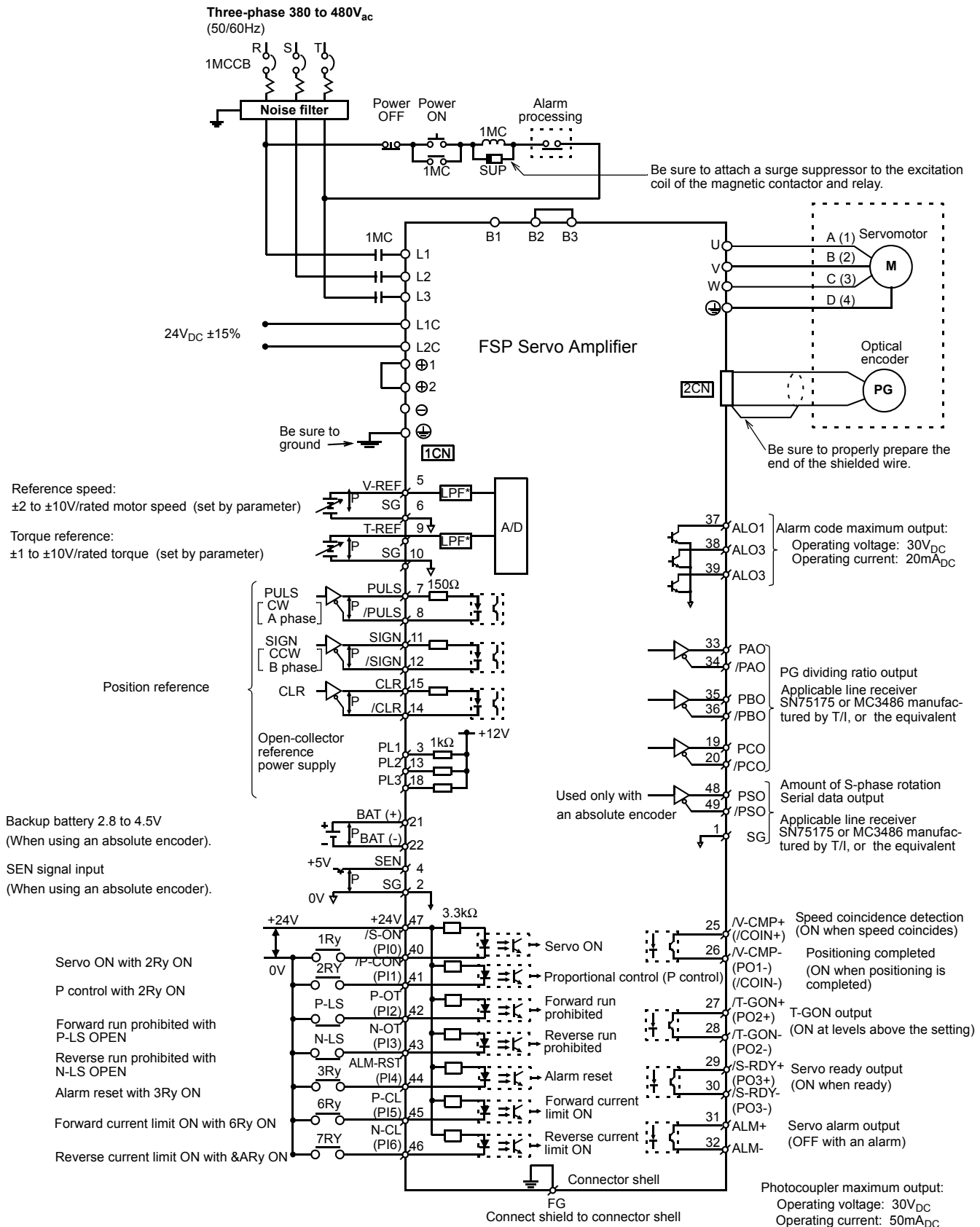

*The time constant for the primary filter is 47μs

⌈P: Indicates twisted wire pairs.