

DWG.NO. 900-010-399

Customer	
Estimate No.	
Order No.	
Item No.	
Application	

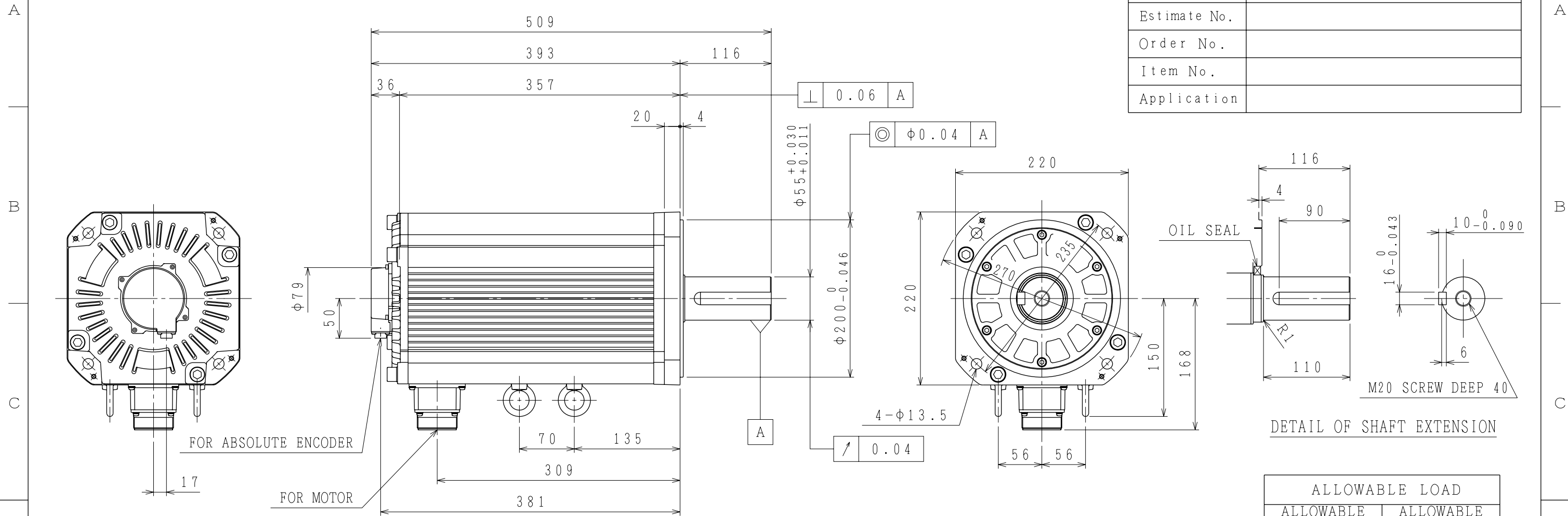

DETAIL OF SHAFT EXTENSION

ALLOWABLE LOAD	
ALLOWABLE RADIAL LOAD N	ALLOWABLE THRUST LOAD N
4998 ( AT END POINT OF SHAFT )	2156

Notes.

- All dimensions in mm.
- Absolute encoder is used as a detector, 20bit.
- Vibration : 15 $\mu$ m or below.
- Plugs and cable clamps are optional.
- Electrical specifications : 900-006-055
- Motors with oil seal should be operated under the following conditions.
  - Optimum oil level should be below oil seal lip.
  - Oil should be splashed to oil seal.
- In case of using this motor for conformable to the "CE" marking or protection degree is IP67, select the plugs and cable clamps by referring to drawing 900-014-203.
- In case of mounting this motor horizontal, to place the connector down is recommendable.

ENCODER TERMINAL CONNECTION

1	DATA+
2	DATA-
3	—
4	+5VDC
5	BATT-
6	BATT+
7	—
8	—
9	0V
10	Frame ground

RECEPTACLE: CM10-R10P-D  
 OPTION:  
 PLUG: CM10-AP10S-\*-D

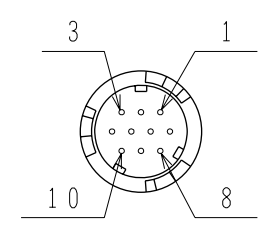

MOTOR TERMINAL CONNECTION

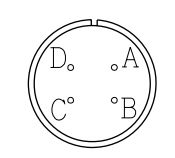

A	Phase U
B	Phase V
C	Phase W
D	Frame ground

RECEPTACLE: CE05-2A32-17PD-D  
 OPTION:  
 PLUG: MS3108B32-17S  
 CABLE CLAMP: MS3057-20A

RATINGS

TYPE	OUTPUT kW	TORQUE N·m	TIME RATING	SPEED min <sup>-1</sup>	CURRENT A	MASS kg
SGMGV-1EA3A6S	15	95.4	CONT.	1500	78	67

REFERENCE ONLY

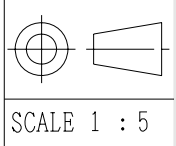

TITLE DIMENSIONS OF AC SERVOMOTOR

DWG.NO. 900-010-399

SIZE A3