

YASKAWA

Efficient AC Drives

Process variables, including pressure and flow of gases and liquids, have long been regulated using mechanical clutches, throttles, and adjustable inlet guide vanes. These schemes waste energy, require frequent maintenance, and provide inaccurate control.

Adjustable frequency drive control provides more efficient, maintenance-free performance, with more accurate control. They have become the preferred method of control for variable speed applications. These drives provide many benefits over traditional control methods. The benefits are both cost and performance related and include:

- use of the rugged, squirrel cage induction motors for reduced cost and easy application,
- advanced performance from digital microprocessor control and serial communications,
- competitive first costs by using standard off-the-shelf components.

Most adjustable frequency drives consist of four basic sections (see figure1):

- The converter section rectifies the AC line input power into the DC bus/filter.
- The DC bus/filter section smooths the DC ripple.
- The driver-regulator section consists of the control, measurement, logic, and command circuits necessary to integrate the drive elements into a system.
- The inverter section converts the filtered DC bus into an AC output.

The voltage level, power level and type of inverter technology determine the size and type of power semiconductors in the converter and inverter sections.

Most inverter sections consist of one of the following solid state switching devices:

- **Bipolar transistors** have a higher switching rate than silicon control rectifiers or gate turn-off thyristors. However, current ratings limit their application to low-power applications where high switching rates are required.
- **Insulated gate bipolar transistors** represent state-of-the-art technology in power semiconductor devices. They have very fast turn-off times, allowing them to switch at rates of up to 15-20 KHz. The current waveform is nearly sinusoidal, reducing peak currents by as much as 42% compared with bipolar transistors. The result is higher available torque throughout the speed range. This eliminates motor noise and reduces motor losses and heating.

The components of the driver-regulator section may use either analog or digital techniques. However, most adjustable frequency drive manufactures are turning to the flexibility of the digital microprocessor-driven regulators.

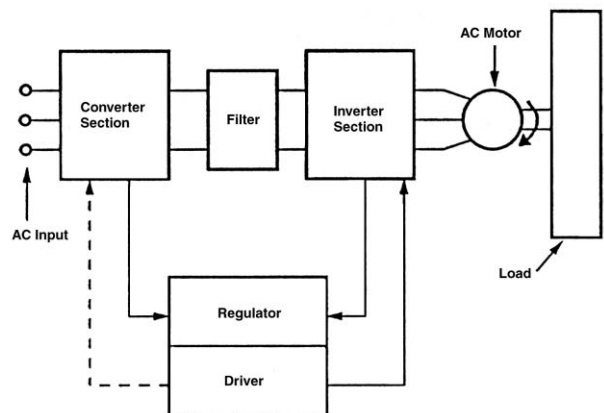

Figure 1



Microprocessors allow manufacturers to include optional control schemes via software modifications. They allow additional functions to be supplied at minimal incremental costs to the user. Furthermore, microprocessors provide enhanced fault diagnostics since most fault data can be stored and viewed at a later time. These features add to the performance and the ability of a single drive design to meet a wide variety of application requirements. As a result of microprocessor-based digital control, adjustable frequency drives are easy to start-up and operate, are resistant to damage and have simple troubleshooting procedures.

Another benefit of microprocessors that contributes to advanced system integration is serial communications protocol for control and monitoring. Many adjustable frequency drives use programmable logic controllers to manage data collection from peripheral controls. This allows the operator to customize the drives with software-executed features and programmable parameters.

A pulse width-modulation inverter controls both the width of, and the spacing between, DC pulses precisely. This allows the inverter to simulate a sinusoidal shaped output pattern. In turn, the output voltage has lower harmonic content. Pulse width-modulations have a wide speed range, smooth low speed operation, multi-motor operation ability, and a high-input power factor. Microprocessors provide improved modulation techniques. Higher-speed switching devices, such as insulated gate bipolar transistors, are making the pulse width-modulation inverter the standard for the 1-500 HP range.

The characteristics of the drive and motor must be considered as a system when applying adjustable frequency drives.

The duty cycle of the inverter-motor combination must be checked at all load conditions to ensure the combination is suitable for the application. It is also important to understand the load requirements. Depending on the application, the load can be classified as one, or a combination of three basic load profiles. (See figure 2).

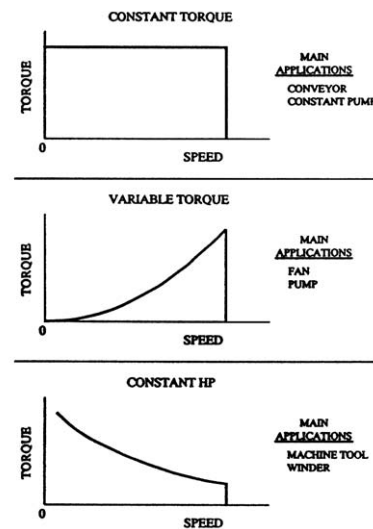

Figure 2

Constant torque

Constant torque implies that any speed in the operating range requires the same amount of driving torque. Conveyors are an example of a constant torque application.

Adjustable frequency drives with many control features are ideal for conveyor applications. With the advanced factory automation, energy-savings during transportation has become essential. Inverters start up from low frequency and low voltage then increase both frequency and voltage. Current and torque are much smaller during acceleration compared to the cross-line start with commercial power supplies. Therefore, an inverter drive can eliminate the reduced voltage start unit.



Since current during acceleration is less, motor heating is reduced, allowing frequent run/stop operations. For example, feed conveyors running at constant speed consume more energy than a conveyor that runs only as fast as necessary. This happens even when there is no material to be fed. If a conveyor changes its speed rapidly, work pieces may be damaged. Such troubles can be avoided and product quality can be stabilized since inverters can change speed slowly by soft start/stop time adjustment. Additional benefits of adjustable frequency drives for conveyor applications include:

- Motors do not require space for speed change as do mechanical converters so that smaller size and lighter weight drives can be used.
- Since totally enclosed fan cooled motors can be used, they are suitable for conveyors under adverse conditions such as constant feeders with excessive dust, sive dust, paint lines with adhesive compositions, or bottling lines.
- Brush or commutators are not part of the induction motor design so maintenance is eliminated.
- Inverters can be used for existing motors under some conditions. By applying an inverter to existing circuits, conveyors which operated at a constant speed can be run at stepless variable speeds.
- A wide range of speed control, up to 40:1, can be controlled remotely by changing frequency reference for optimum speed.
- Since phase-rotation switching of inverter transistors performs the forward/ reverse operation, conventional main circuit contactors, are not required.

Variable torque

Often, variable torque loads require the driving torque to vary proportionally with the speed of the load. HVAC systems are an example of a variable torque application.

Centrifugal fans and pumps are sized to meet the maximum flow rate required by the system. In most applications however, maximum demand volume is required for only a small percentage of the total operating time. Most of the operating time is spent providing 40% to 70% capacity. For centrifugal devices, the torque varies by the square of speed and the horsepower varies by the cube of speed. Reduced fan speed achieves reduced air volume and reduces motor power consumption.

Most pumps are centrifugal and their operation is defined by two independent curves. One is the pump curve—a function of the pump geometry and motor characteristics. The other is the system curve which depends on the geometry of the piping and valves connected to the pump. The intersection of these curves determines the natural operating point. If the system is part of a process that requires adjustable flow rates, then some method is needed to alter either the system characteristics or the pump parameters. These methods include valves or throttling to change the system curve or an adjustable frequency drive on the pump to modify the pump curve.

For a specific flow rate, the difference between points A and B gives a visual indication of possible energy savings

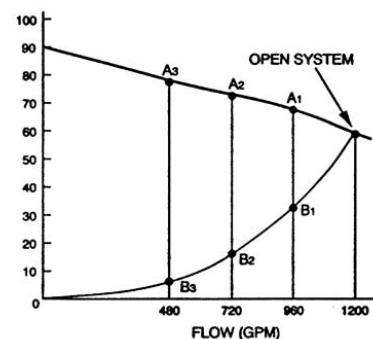

Figure 3



Constant Horsepower

Constant horsepower loads require high torques at low speeds and low torques at high speeds. Machine tool applications are perfect examples of such loads.

In gear-type speed changers, spindle speed can be selected only in steps so that delicate peripheral speed constant control is not available. Although dc spindles can make stepless speed changes, they are expensive, inefficient, and require regular brush maintenance. Using adjustable frequency drives for spindle drives eliminate these problems. Since a standard motor can achieve stepless spindle drive speed changes, the clutch mechanism can be eliminated. An adjustable frequency drive used in place of a gear-type or dc spindle provides the following benefits:

- higher accuracy in cutting of soft workpieces
- elimination of brush maintenance
- improved efficiency-field winding is not needed.
- increased machine output

Automated grinding is another constant horsepower application. Grinding speed requirements range from 20,000 to 180,000 rpm. At the beginning of a typical grinding cycle the wheel moves toward the work-piece at a fast feed rate. Then, at a safe distance, the feed rate slows to the normal grinding rate as it approaches the surface. However, due to variations in part dimensions, the distance traveled to reach the work piece at the slow rate can be significant.

To overcome this hurdle, some adjustable frequency drives offer a load sensing circuit to produce a signal that is a function of the current drawn by the grinding wheel drive motor. With this feature, the grinding wheel advances at a fast rate toward the work piece until it makes contact. Within 20 to 40 milliseconds after the wheel contacts the work piece, the adjustable frequency drive produces a signal that adjusts the feed rate to the normal lower value.

Conclusion

The use of adjustable frequency drives makes an important contribution to the efficient operation of industrial and commercial equipment.

The advances in the area of adjustable frequency drives have led to high-tech cost effective solutions that offer substantial advantages over both mechanical systems and dc drives.

The most effective adjustable frequency drives use state-of-the-art technology. Pulse width-modulation combined with microprocessor control provides optimum induction motor control and superior flexibility. The combination of insulated gate bipolar transistors and surface mounted device technology have allowed a more compact and less complex design with reduced costs compared to other variable speed drive technologies.