



YASKAWA

Static Duct Pressure Control. PID functions are incorporated into the Yaskawa AC drive. The PID algorithm is the “brain” of a closed control loop, responsible for maintaining SETPOINT and reducing loop error. This gives the drive the capability to regulate a controlled variable, such as supply duct pressure. Regulation is accomplished by comparing a feedback signal to a SETPOINT signal. The SETPOINT signal can be programmed into the drive, or can be provided by an analog input to the drive.

The PID algorithm then performs the necessary calculations on the difference between the two signals (Error Signal), in order to compensate for load changes, and output the motor speed required to maintain SETPOINT.

Figure 1 shows how the drive can accomplish static duct pressure modulation in response to changing system load, thereby significantly reducing the energy required compared to constant air volume application.

The drive is controlled by a differential pressure transmitter or transducer positioned about 2/3 of the distance to the end of the distribution system. The drive accepts an analog signal from the transducer and adjusts fan speed to maintain the differential pressure setpoint. The SETPOINT can be programmed directly into the drive.

The controlled variable is sensed and conditioned by a transducer to provide the controlled variable signal. Yaskawa recommends a transducer such as the Mamac Systems Model PR-274, or equivalent. See Figure 2 and the manufacturer’s bulletin.

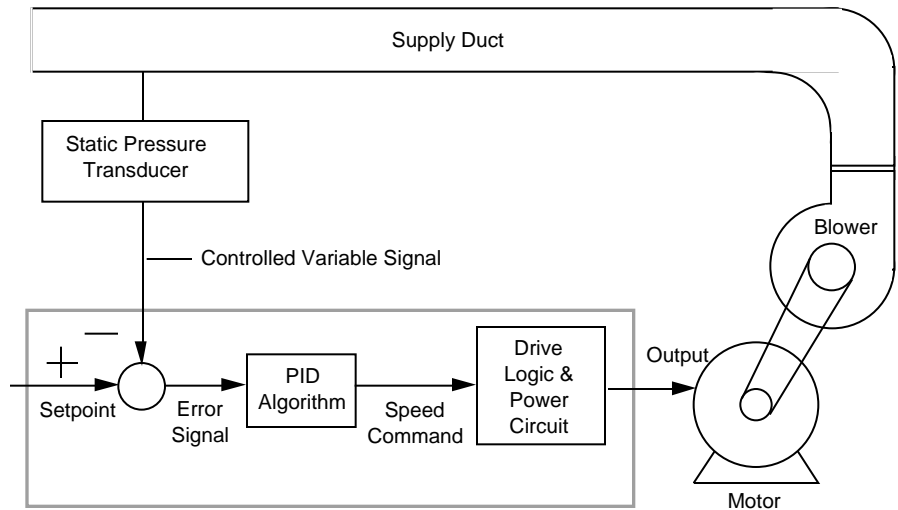

Figure 1

Note: Another application for this transducer is building static pressure control with the "HI" port sensing inside pressure and the "LO" port sensing outside pressure. In this application, the drive controls the return fan and the transducer is reverse acting.



Static Duct Pressure PID Control

Suggested ordering example for this Application:

MAMAC Model PR-274-R2-VDC.

This example provides the following features:

- 0-5 VDC or 0-10 VDC Output
- 0 - 3" WCD Input
- 24 VAC Power Supply
- Direct Acting Output
- With Output averaging
- With Output clipping
- With enclosure & 1/4" barb fittings

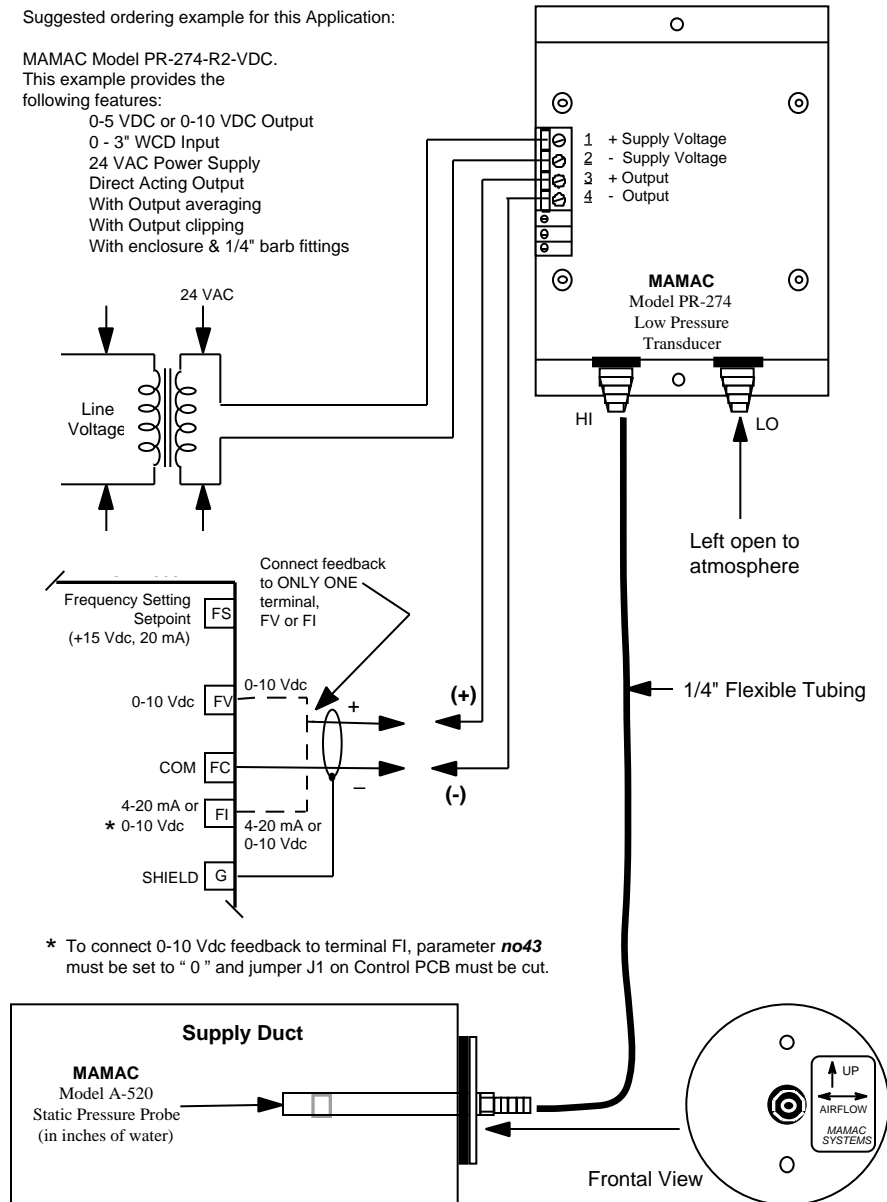

* To connect 0-10 Vdc feedback to terminal FI, parameter **no43** must be set to "0" and jumper J1 on Control PCB must be cut.