

The dimensions shown are for an IP20 drive that has been converted to a UL Type 1 drive by adding the parts from UL Type 1 kit part number ZBAA-GA50V1-1

C/C: GA50□	INPUT VOLTAGE (VAC)	WEIGHT Kg (lb)	COOLING FANS
B001□□□	200 TO 240 1-PHASE	0.7 (1.5)	0
B002□□□	200 TO 240 3-PHASE	0.7 (1.5)	0
2001□□□	200 TO 240 1-PHASE	0.7 (1.5)	0
2002□□□	200 TO 240 3-PHASE	0.7 (1.5)	0

□ denotes A-Z

**YASKAWA**

UNITS MM [IN]  
SCALE 1:2

DRWN. J. MATTAS 10-18-19  
 CHKD. J. PIOTROWSKI 11-4-19  
 TECH. L. UDDIN 11-18-19  
 APRV. J. CAIRO 11-19-19

TITLE  
 GA500 DIMENSION DRAWING  
 FRAME SIZE 1.1  
 UL TYPE 1 ENCLOSURE

SIZE A PAGE 1 OF 4  
 DWG.NO. DD.GA50.FR1.1.T1

REV 0

# Terminal and Wiring Information for GA50□B001 and GA50□B002

FRONT VIEW

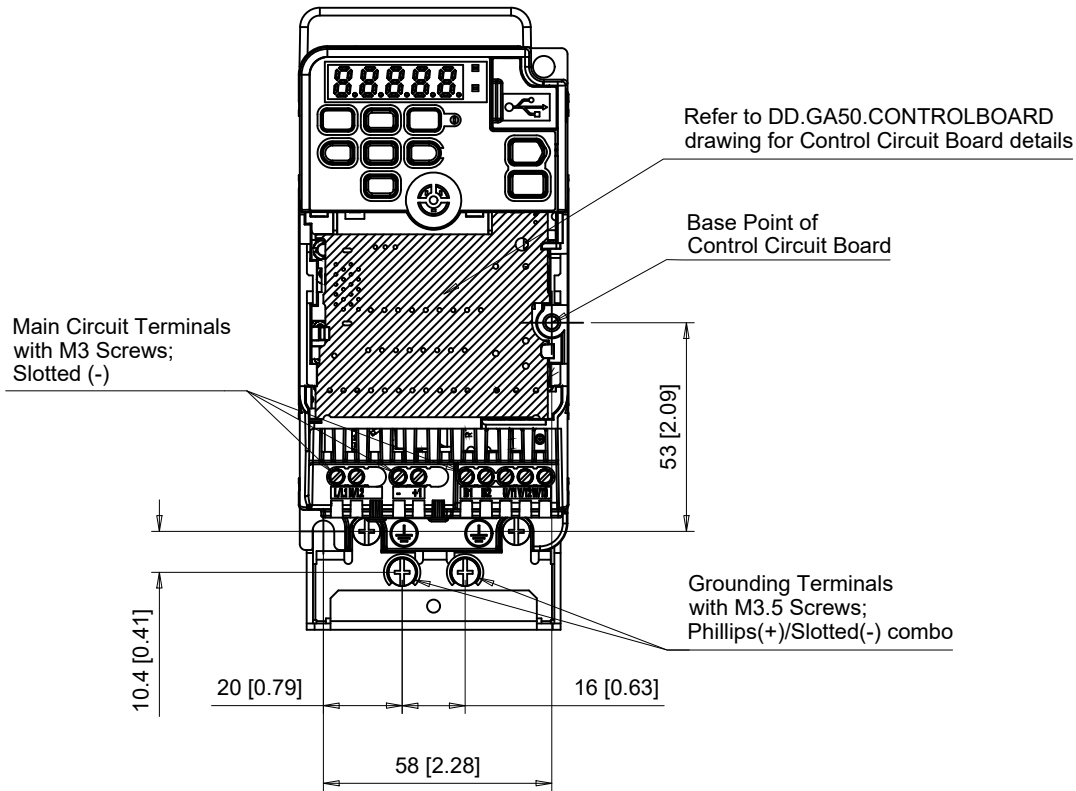

BOTTOM VIEW

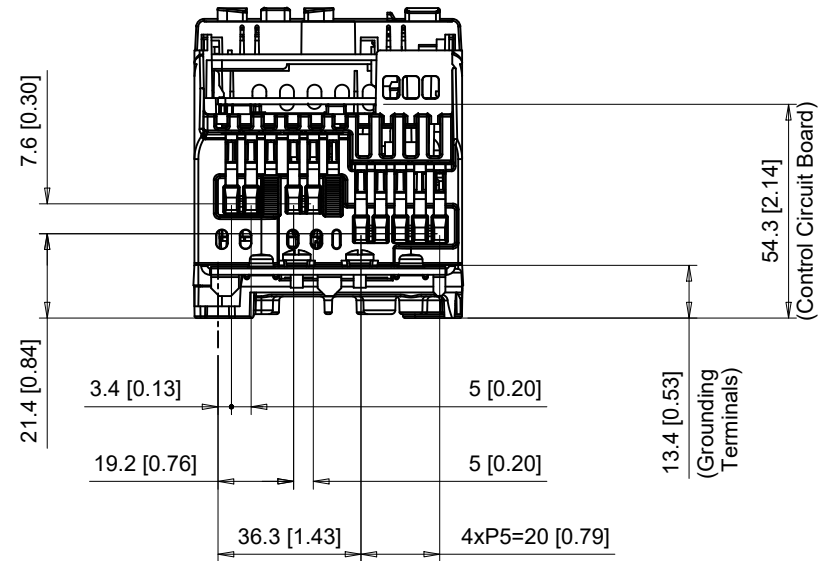

C/C: GA50□	TERMINAL SYMBOL	WIRE RANGE AWG (mm <sup>2</sup> )	TERMINAL SCREW	CLAMPING TORQUE N.m. (lb.in.)
B001□□□	L/L1, N/L2	14 - 12 (2.5 - 4)	M3	0.6 - 0.8 (5 - 7)
	U/T1, V/T2, W/T3	14 - 12 (2.5 - 4)	M3	0.6 - 0.8 (5 - 7)
B002□□□	-, +1	14 - 12 (2.5 - 4)	M3	0.6 - 0.8 (5 - 7)
	B1, B2	14 - 12 (2.5 - 4)	M3	0.6 - 0.8 (5 - 7)
	⊕	14 (2.5)	M3.5	0.8 - 1.0 (7 - 9)

□ Denotes A-Z

Note: Refer to applicable codes and standards for proper wire type and size.

**YASKAWA**

UNITS MM [IN]  
SCALE 1:2

DRWN. J. MATTAS 10-18-19  
CHKD. J. PIOTROWSKI 11-4-19  
TECH. L. UDDIN 11-18-19  
APRV. J. CAIRO 11-19-19

TITLE  
GA500 DIMENSION DRAWING  
FRAME SIZE 1.1  
UL TYPE 1 ENCLOSURE

SIZE A PAGE 2 OF 4  
DWG.NO. DD.GA50.FR1.1.T1

REV 0

# Terminal and Wiring Information for GA50□2001 and GA50□2002

FRONT VIEW

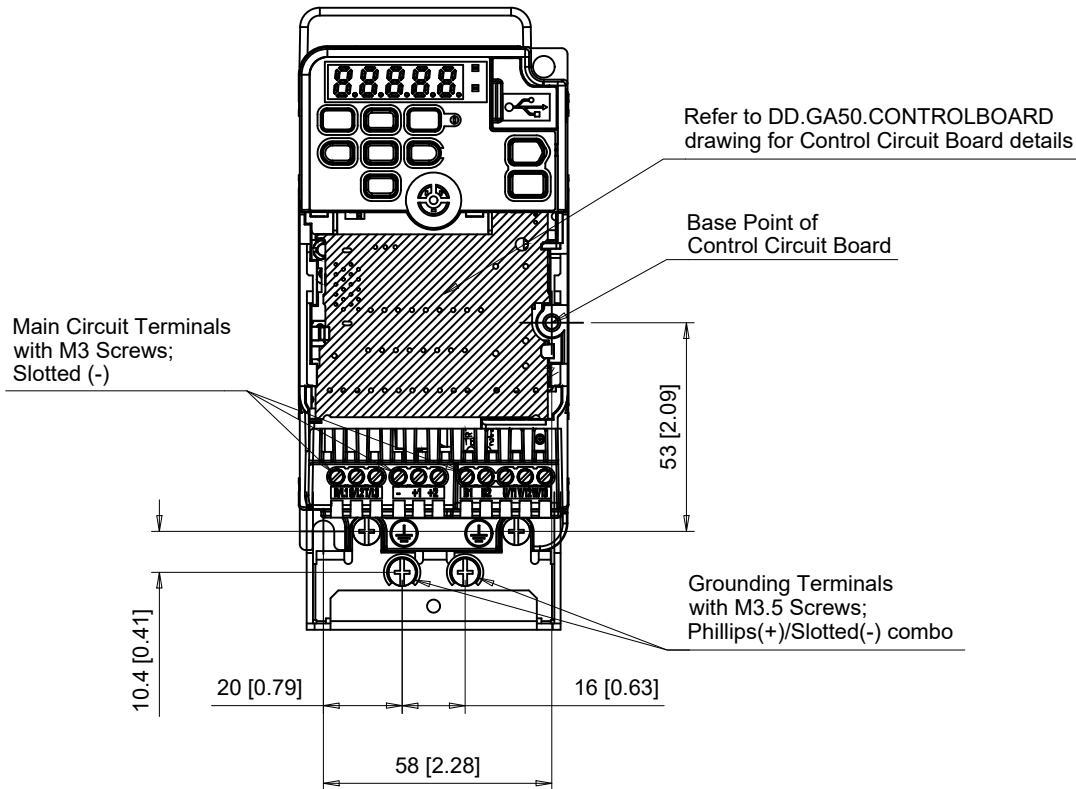

BOTTOM VIEW

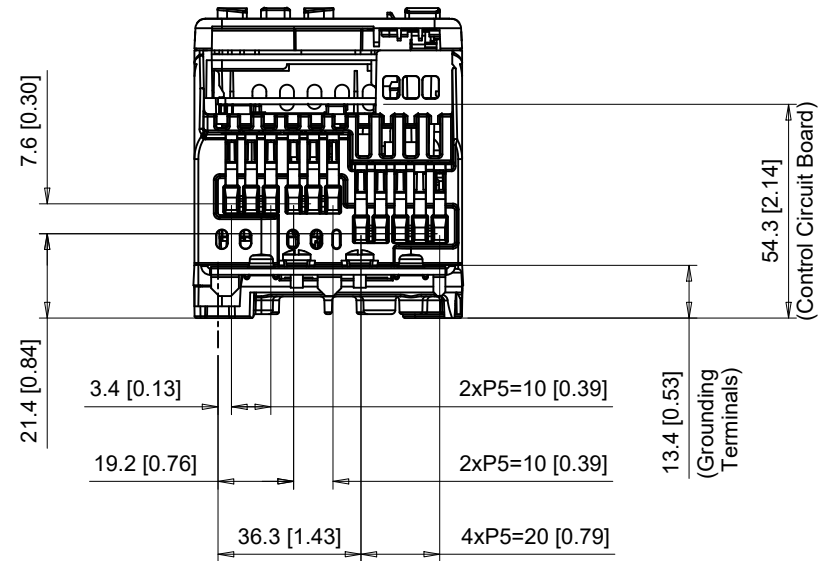

C/C: GA50□	TERMINAL SYMBOL	WIRE RANGE AWG (mm <sup>2</sup> )	TERMINAL SCREW	CLAMPING TORQUE N.m. (lb.in.)
2001□□□	R/L1, S/L2, T/L3	14 - 12 (2.5 - 4)	M3	0.6 - 0.8 (5 - 7)
	U/T1, V/T2, W/T3	14 - 12 (2.5 - 4)	M3	0.6 - 0.8 (5 - 7)
2002□□□	-, +1, +2	14 - 12 (2.5 - 4)	M3	0.6 - 0.8 (5 - 7)
	B1, B2	14 - 12 (2.5 - 4)	M3	0.6 - 0.8 (5 - 7)
	⊕	14 (2.5)	M3.5	0.8 - 1.0 (7 - 9)

□ Denotes A-Z

Note: Refer to applicable codes and standards for proper wire type and size.

**YASKAWA**



UNITS MM [IN]

SCALE 1:2

DRWN.	J. MATTAS	10-18-19
CHKD.	J. PIOTROWSKI	11-4-19
TECH.	L. UDDIN	11-18-19
APRV.	J. CAIRO	11-19-19

TITLE  
GA500 DIMENSION DRAWING  
FRAME SIZE 1.1  
UL TYPE 1 ENCLOSURE

SIZE A PAGE 3 OF 4  
DWG.NO. DD.GA50.FR1.1.T1

REV  
0

Minimum Installation Clearances

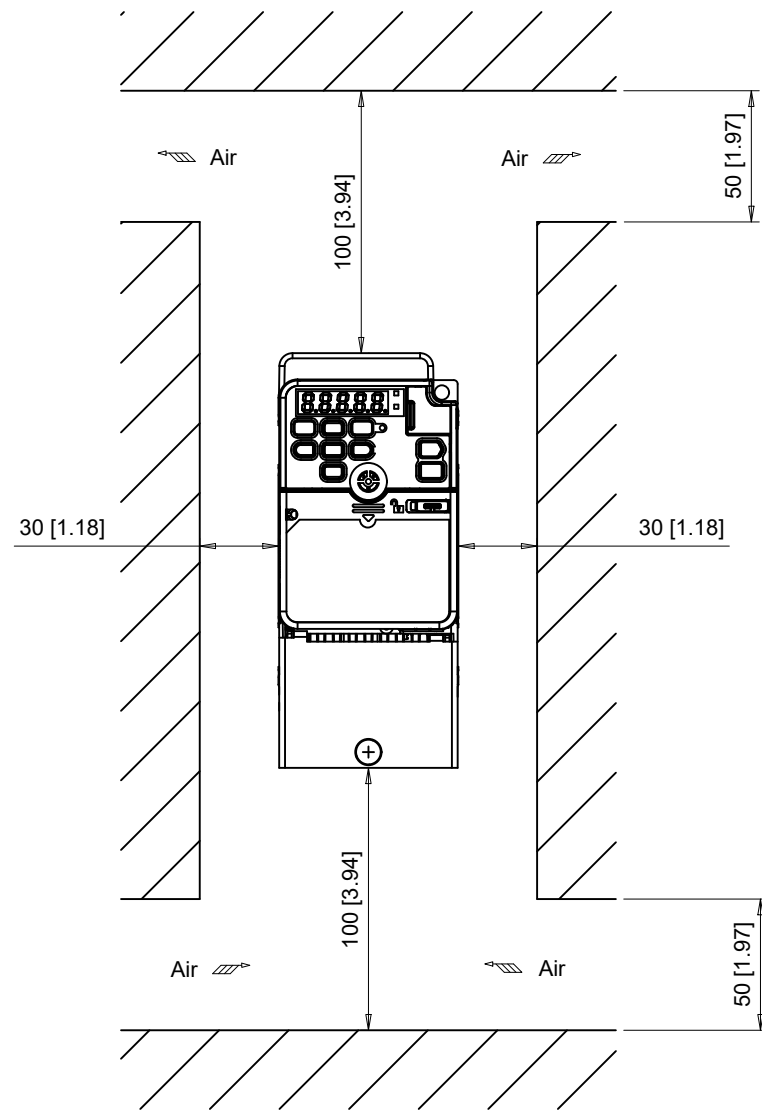

Note:  
For alternate mounting configurations, consult manual.

**YASKAWA**

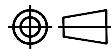

UNITS MM [IN]  
SCALE 1:3

DRWN.	J. MATTAS	10-18-19
CHKD.	J. PIOTROWSKI	11-4-19
TECH.	L. UDDIN	11-18-19
APRV.	J. CAIRO	11-19-19

TITLE  
GA500 DIMENSION DRAWING  
FRAME SIZE 1.1  
UL TYPE 1 ENCLOSURE

SIZE A	PAGE 4 OF 4
DWG.NO. DD.GA50.FR1.1.T1	

REV  
0