

The dimensions shown are for an IP20 drive that has been converted to a UL Type 1 drive by adding the parts from UL Type 1 kit part number ZBAA-GA50V2-4

C/C: GA50□	INPUT VOLTAGE (VAC)	WEIGHT Kg (lb)	COOLING FANS
4002□□□	380 TO 480 3-PHASE	1.1 (2.5)	0

□ denotes A-Z

YASKAWA



UNITS MM [IN]

SCALE 1:3

DRWN. J. MATTAS 10-21-19
CHKD. J. PIOTROWSKI 11-4-19
TECH. L. UDDIN 11-18-19
APRV. J. CAIRO 11-19-19

TITLE
GA500 DIMENSION DRAWING
FRAME SIZE 2.2
UL TYPE 1 ENCLOSURE

SIZE A PAGE 1 OF 3
DWG.NO. DD.GA50.FR2.2.T1

REV
0

FRONT VIEW

BOTTOM VIEW

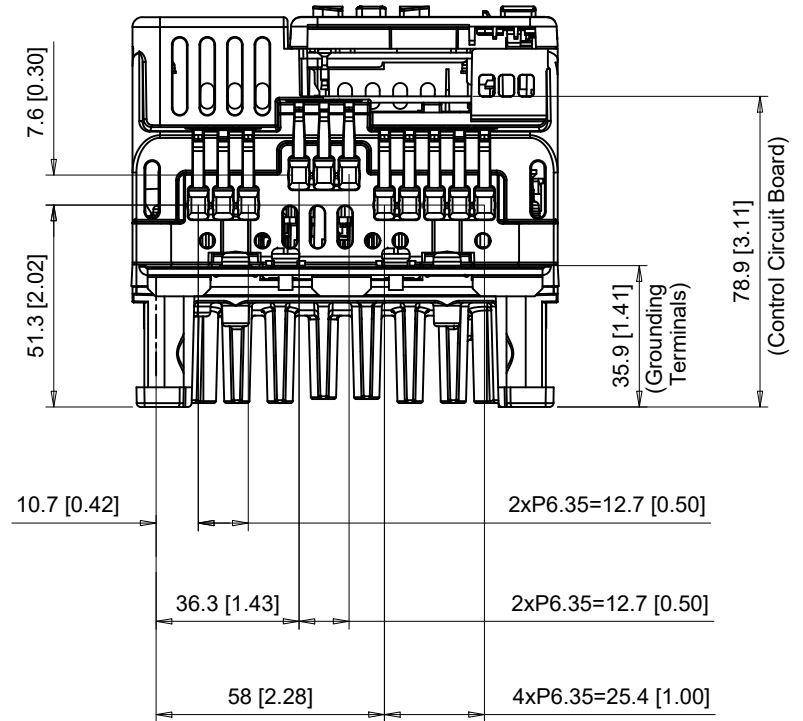
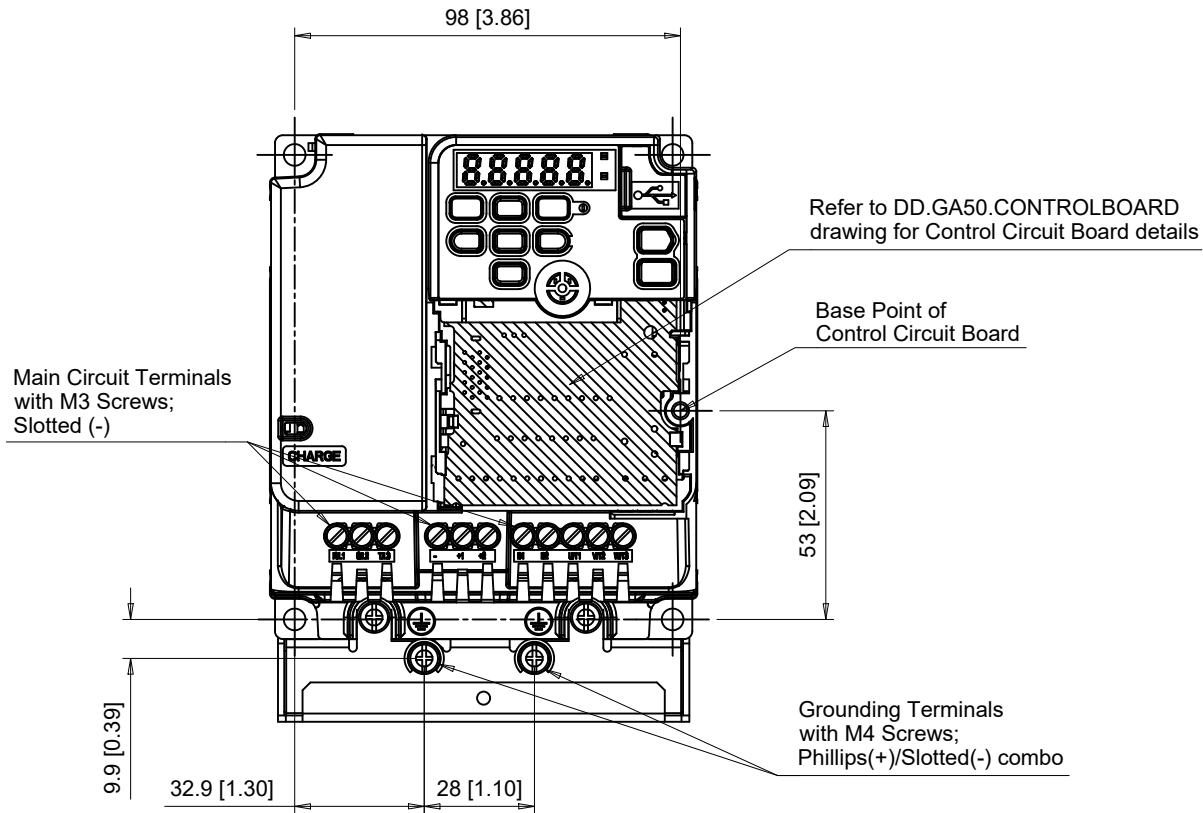

C/C: GA50□	TERMINAL SYMBOL	WIRE RANGE AWG (mm ²)	TERMINAL SCREW	CLAMPING TORQUE N.m. (lb.in.)
4002□□□	R/L1, S/L2, T/L3	14 - 10 (2.5 - 6)	M3	0.6 - 0.8 (5 - 7)
	U/T1, V/T2, W/T3	14 - 10 (2.5 - 6)	M3	0.6 - 0.8 (5 - 7)
	-, +1, +2	14 - 10 (2.5 - 6)	M3	0.6 - 0.8 (5 - 7)
	B1, B2	14 - 10 (2.5 - 6)	M3	0.6 - 0.8 (5 - 7)
	⊕	14 - 10 (2.5 - 6)	M4	1.2 - 1.5 (11 - 13)

□ Denotes A-Z

Note: Refer to applicable codes and standards for proper wire type and size.

YASKAWA

UNITS MM [IN]
SCALE 1:2

DRWN. J. MATTAS 10-21-19
 CHKD. J. PIOTROWSKI 11-4-19
 TECH. L. UDDIN 11-18-19
 APRV. J. CAIRO 11-19-19

TITLE
 GA500 DIMENSION DRAWING
 FRAME SIZE 2.2
 UL TYPE 1 ENCLOSURE

SIZE A PAGE 2 OF 3
 DWG.NO. DD.GA50.FR2.2.T1

REV 0

Minimum Installation Clearances

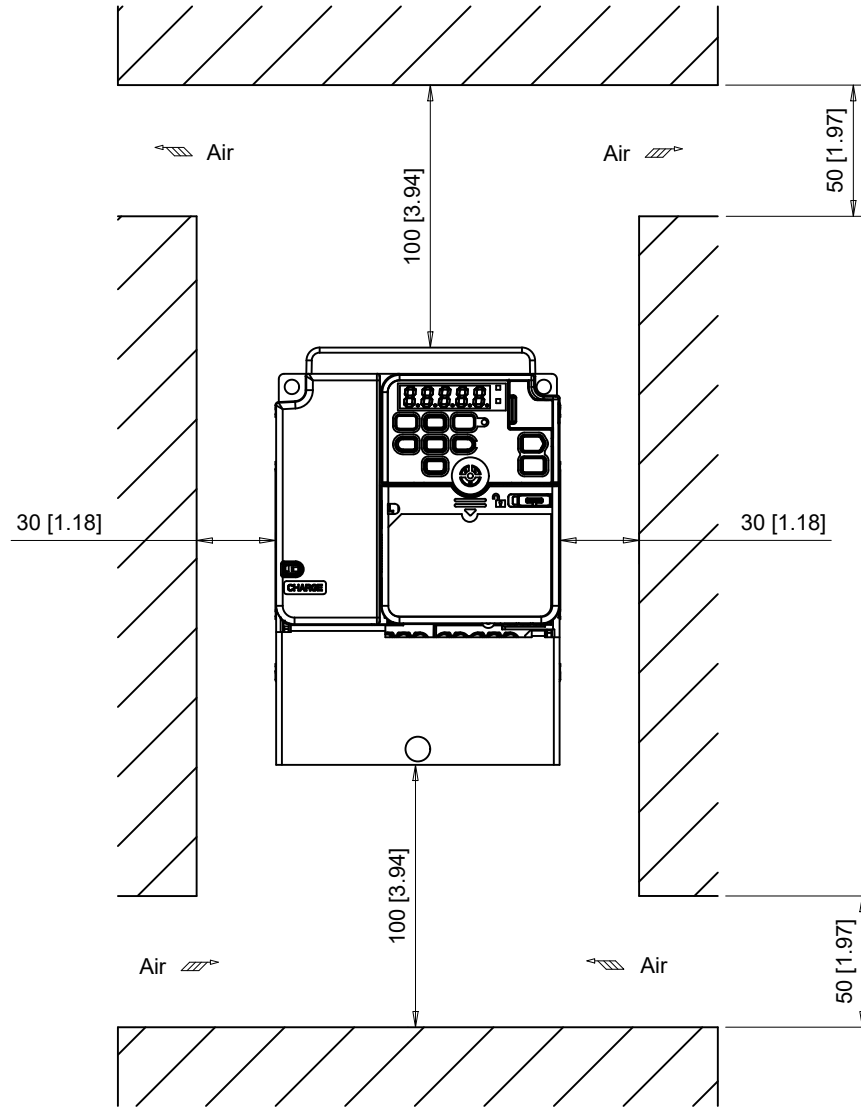

Note:
For alternate mounting configurations, consult manual.

YASKAWA

UNITS MM [IN]
SCALE 1:3

DRWN.	J. MATTAS	10-21-19
CHKD.	J. PIOTROWSKI	11-4-19
TECH.	L. UDDIN	11-18-19
APRV.	J. CAIRO	11-19-19

TITLE
GA500 DIMENSION DRAWING
FRAME SIZE 2.2
UL TYPE 1 ENCLOSURE

SIZE A	PAGE 3 OF 3
DWG.NO. DD.GA50.FR2.2.T1	

REV
0