

(2) EXTERNAL COOLING FANS

NOTE:
REMOVE THE TOP PROTECTIVE COVER TO OBTAIN THE
MAXIMUM SURROUNDING AIR TEMPERATURE RATING OF
122F(50C).

TOP PROTECTIVE COVER

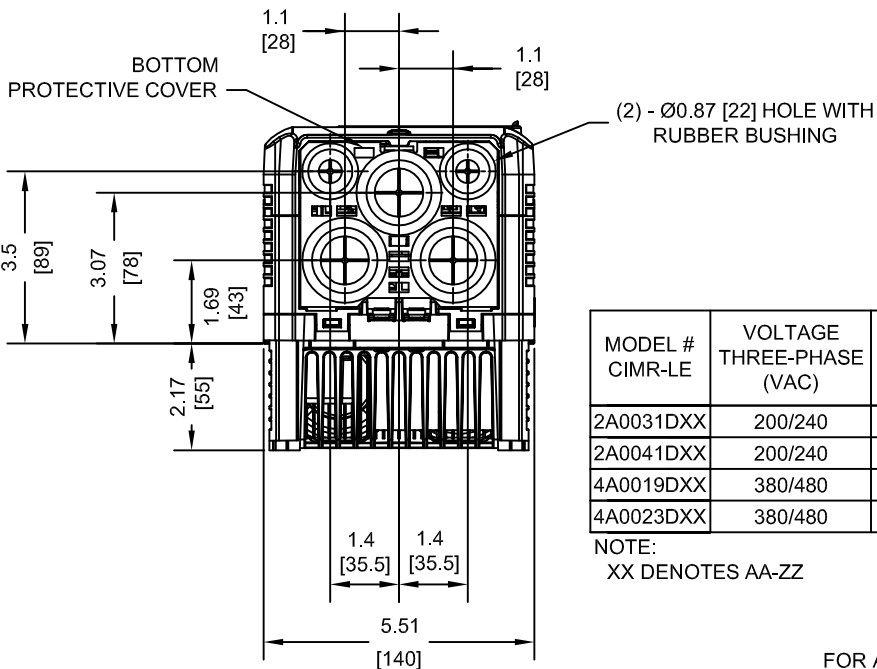
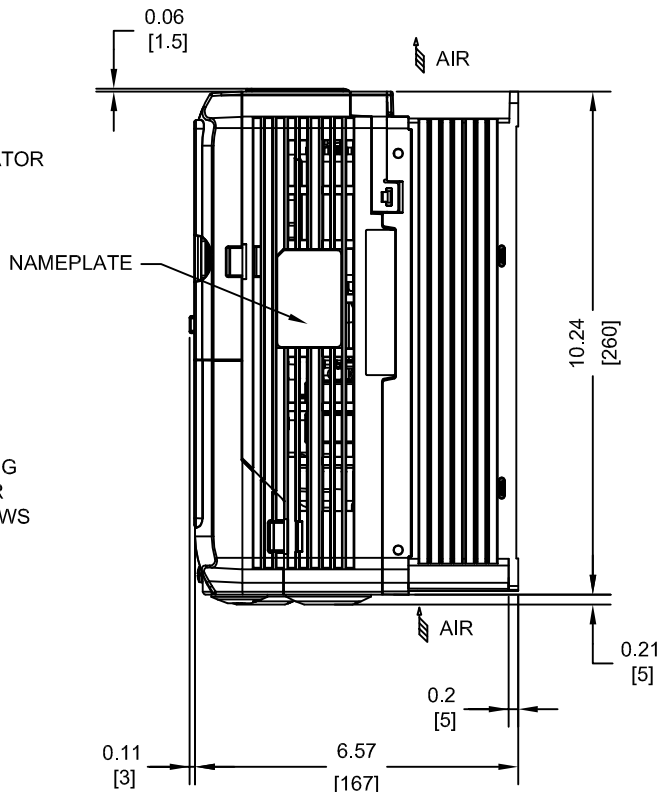
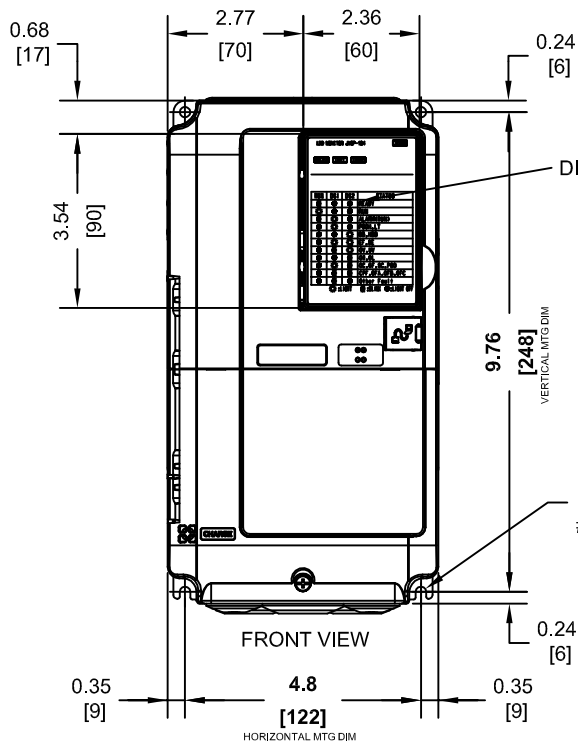

MODEL # CIMR-LE	VOLTAGE THREE-PHASE (VAC)	OUTPUT CURRENT (A) 3 MIN., 50% ED	WEIGHT LBS (Kg)	HEAT LOSS (W) Fc=8kHz		
				INT	EXT	TOT
2A0031DXX	200/240	31.3	8.8 (4.0)	92.3	194.4	286.6
2A0041DXX	200/240	41.3	8.8 (4.0)	104.8	213.8	318.7
4A0019DXX	380/480	18.5	8.6 (3.9)	85.7	135.4	221.1
4A0023DXX	380/480	22.5	8.9 (4.0)	97.0	149.9	246.9

NOTE:
XX DENOTES AA-ZZ

INT=INTERNAL COMPONENTS
EXT=EXTERNAL HEATSINK
TOT=TOTAL

FOR ADDITIONAL DETAILS AND SPECIFICATIONS, CONSULT MANUAL

TOLERANCES / REFERENCES:



THIS DOCUMENT AND INFORMATION CONTAINED
IN IT ARE CONFIDENTIAL, AND CANNOT BE
COPIED OR DISCLOSED IN WHOLE OR IN PART
WITHOUT THE EXPRESS WRITTEN CONSENT
OF YASKAWA AMERICA, INC.

DRAWN: J. MATTAS	DATE 11-22-13
CHECKED: J. PIOTROWSKI	DATE 11-24-13
TECH: L. UDDIN	DATE 12-2-13
APPROVED: J. CAIRO	DATE 12-21-13
ORIGINAL DESIGN: -	DATE -

TITLE: L1000E DIMENSION DRAWING FRAME SIZE 3 IP00 ENCLOSURE 2A0031 - 41, 4A0019 - 23		
SIZE A	REVISION R00	PAGE 1 of 3
DRAWING #: DD.L1KE.FR3.IP00		

UNITS:
IN [mm]

SCALE:
1:4

TERMINAL AND WIRING DETAILS (SCALE 1:3)

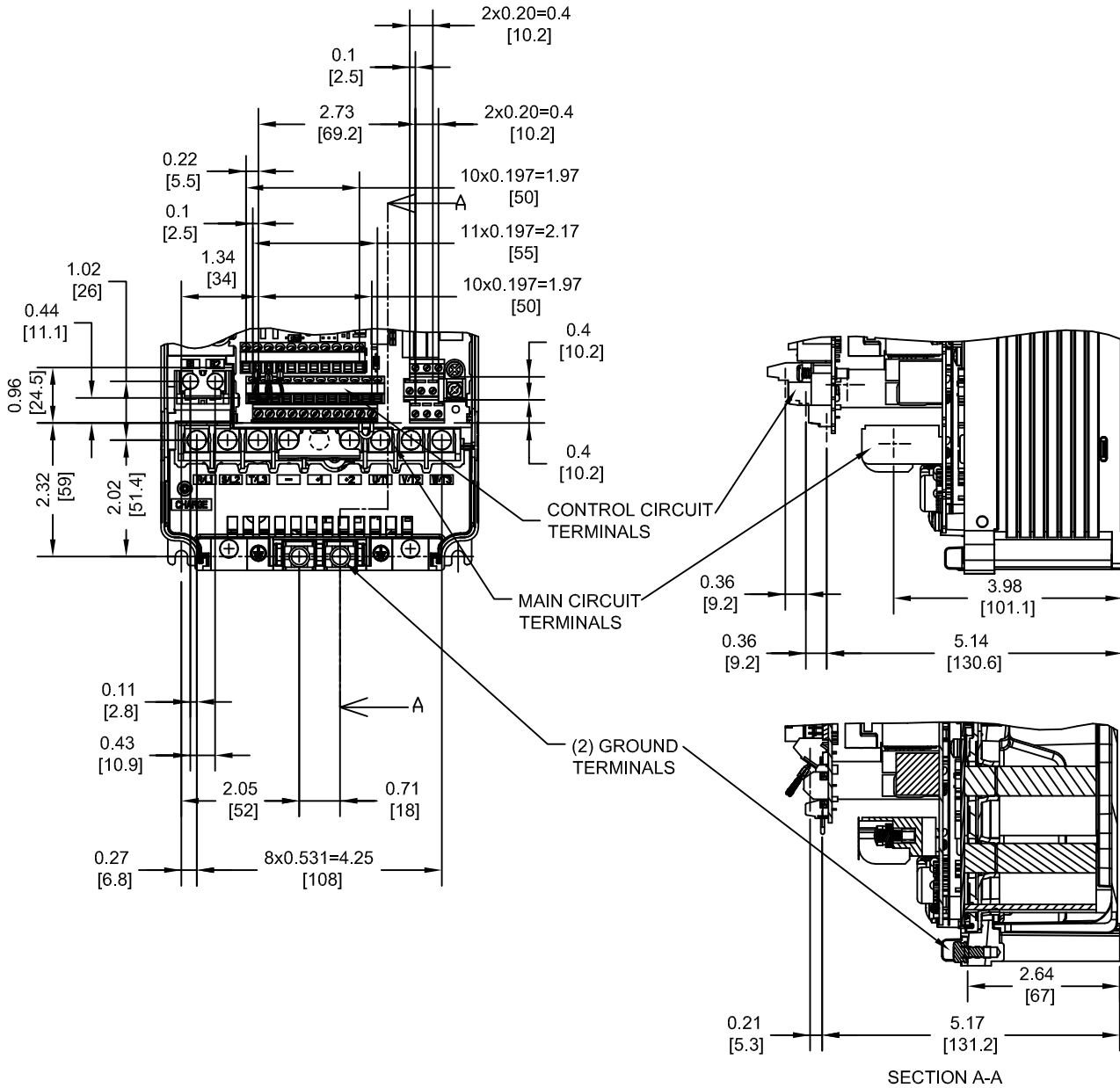

TERMINAL AND WIRE SPECIFICATIONS FOR MAIN CIRCUIT AND GROUND

MODEL # CIMR-LE	TERMINAL SYMBOL	TERMINAL SCREW	CLAMPING TORQUE lb.in.(N.m.)	WIRE RANGE AWG(mm ²)
2A0031 2A0041 4A0019 4A0023	R/L1, S/L2, T/L3, U/T1, V/T2, W/T3,	M4	20.4 (2.3)	10-6 (6.0-16)
	⊖, ⊕1, ⊕2,			12-6 (4.0-16)
	B1, B2			12-10 (4.0-6.0)
	⊕	M5	17.7 TO 22.1 (2 TO 2.5)	12-10 (4.0-6.0)

NOTE: REFER TO APPLICABLE CODES FOR PROPER WIRE TYPE AND SIZE

FOR ADDITIONAL DETAILS AND SPECIFICATIONS, CONSULT MANUAL

TOLERANCES / REFERENCES:			DRAWN: J. MATTAS DATE 11-22-13	TITLE: L1000E DIMENSION DRAWING FRAME SIZE 3 IP00 ENCLOSURE 2A0031 - 41, 4A0019 - 23
UNITS: IN [mm] SCALE: BY VIEW			CHECKED: J. PIOTROWSKI DATE 11-24-13	TECH: L. UDDIN DATE 12-2-13
THIS DOCUMENT AND INFORMATION CONTAINED IN IT ARE CONFIDENTIAL, AND CANNOT BE COPIED OR DISCLOSED IN WHOLE OR IN PART WITHOUT THE EXPRESS WRITTEN CONSENT OF YASKAWA AMERICA, INC.		APPROVED: J. CAIRO DATE 12-21-13	ORIGINAL DESIGN: - DATE -	DRAWING #: DD.L1KE.FR3.IP00

MINIMUM INSTALLATION CLEARANCES (SCALE 1:4)

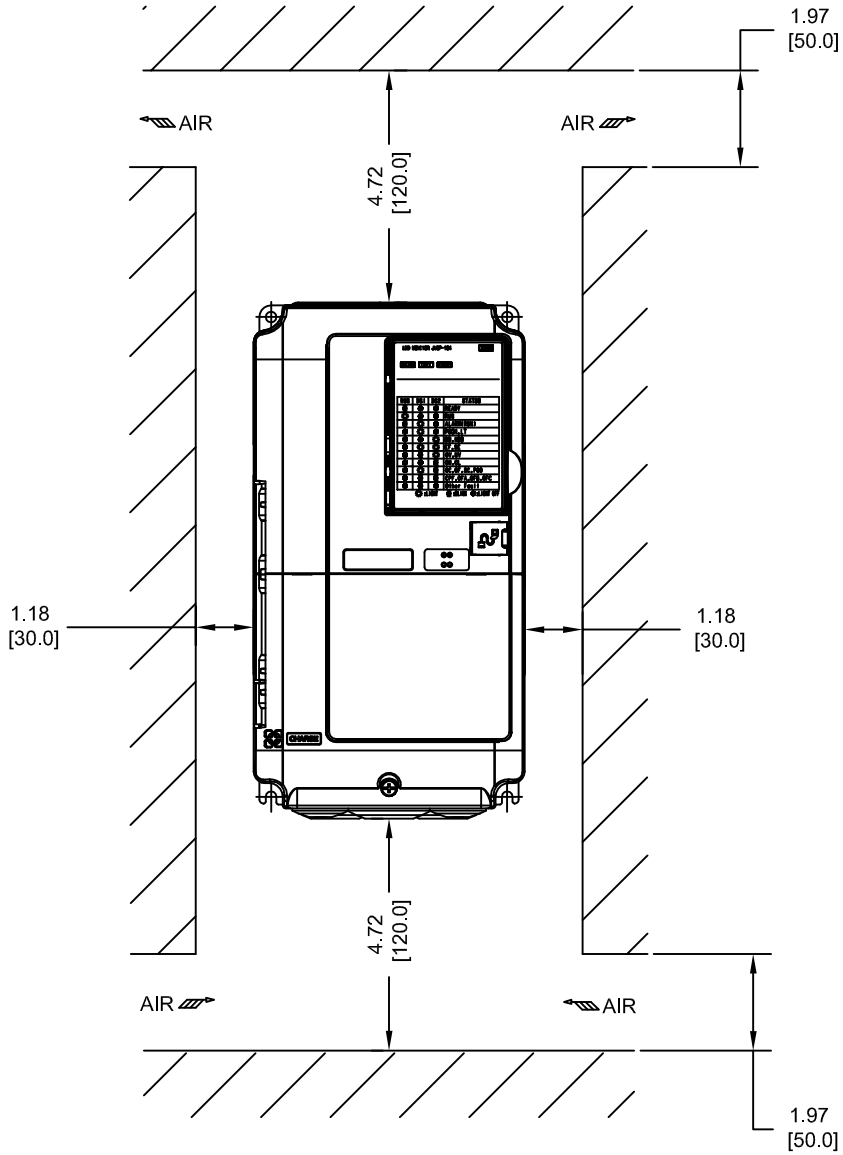

FOR ADDITIONAL DETAILS AND SPECIFICATIONS, CONSULT MANUAL

TOLERANCES / REFERENCES:		 <p>THIS DOCUMENT AND INFORMATION CONTAINED IN IT ARE CONFIDENTIAL, AND CANNOT BE COPIED OR DISCLOSED IN WHOLE OR IN PART WITHOUT THE EXPRESS WRITTEN CONSENT OF YASKAWA AMERICA, INC.</p>	DRAWN: J. MATTAS	DATE 11-22-13	TITLE: L1000E DIMENSION DRAWING FRAME SIZE 3 IP00 ENCLOSURE 2A0031 - 41, 4A0019 - 23
			CHECKED: J. PIOTROWSKI	DATE 11-24-13	
			TECH: L. UDDIN	DATE 12-2-13	
			APPROVED: J. CAIRO	DATE 12-21-13	
UNITS: IN [mm]	SCALE: BY VIEW	ORIGINAL DESIGN:	-	DATE	-
					DRAWING #: DD.L1KE.FR3.IP00
			SIZE A	REVISION R00	PAGE 3 of 3