

CONTROL TRANSFORMER PRIMARY CONNECTIONS			
INPUT VOLTS	TERMINALS A	TERMINALS B	JUMPER LOCATION
230/240	(H1)	(H4)	(H1) TO (H3) (H2) TO (H4)
460/480	(H1)	(H4)	(H2) TO (H3)
600	(H1)	(H2)	NONE

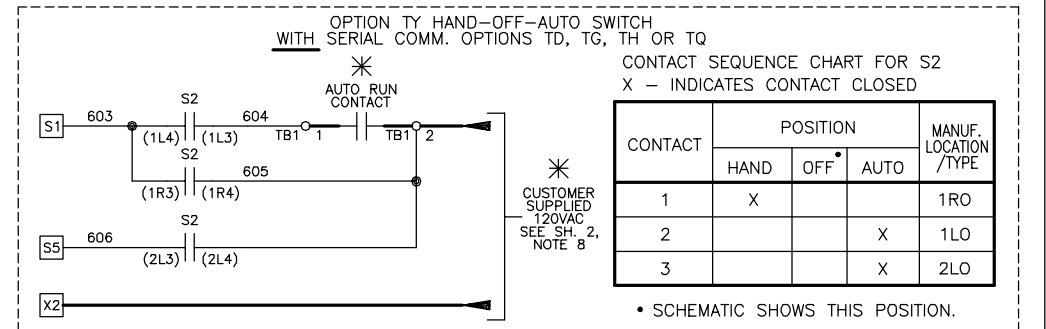

BLOWER MOTOR		
FLA RATING	AMPS	VOLTS
3.0	4.2 - 360	240
1.5	2.1 - 477	480
3.0	5.15 - 720	480

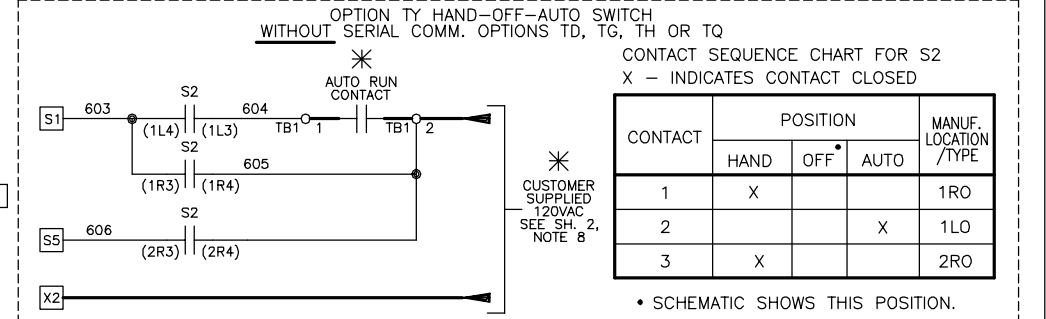
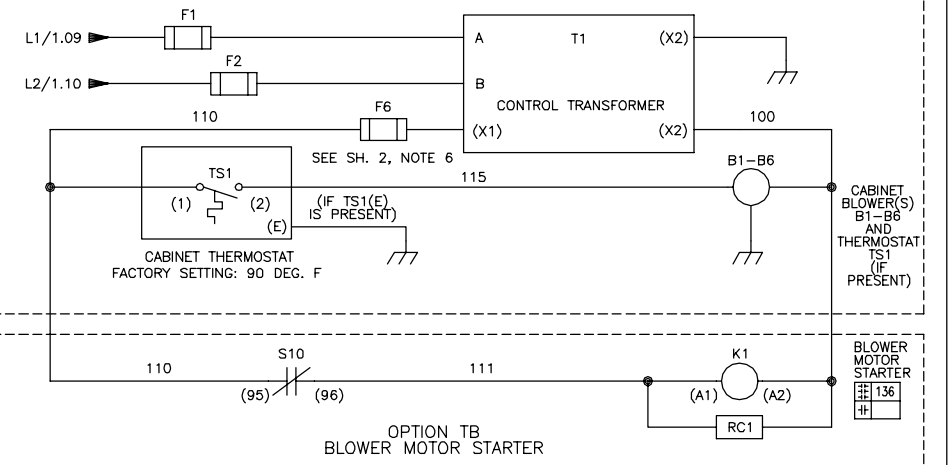
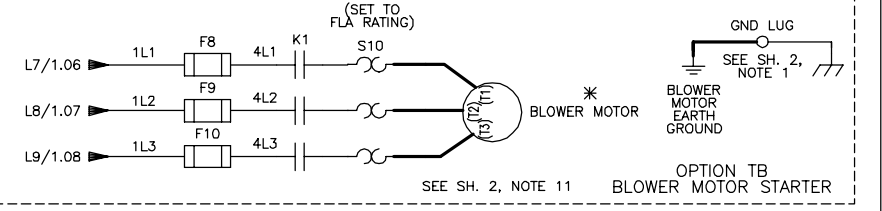

* - INDICATES COMPONENTS NOT SUPPLIED BY YASKAWA.
 - INDICATES CUSTOMER WIRING.
 - CONNECTED TO THE CABINET OR PANEL.
 SEE SHEET 2 FOR NOTES.
 SEE DRAWING UDE00577 FOR CUSTOMER CONNECTIONS.
 SEE DRAWING UDE00579 FOR DRIVE PARAMETER SETTINGS.

REVISIONS			
REV	DESCRIPTION	ECD #	DRAWN BY
03	ADDED INPUT FUSES TO B361-B720, NOTE 12	11302	KM
02	ADDED OPTION TB	10925	KAP

YASKAWA

THIS DOCUMENT AND INFORMATION CONTAINED IN IT ARE CONFIDENTIAL, AND CANNOT BE COPIED OR DISCLOSED IN WHOLE OR IN PART WITHOUT THE EXPRESS WRITTEN CONSENT OF YASKAWA AMERICA, INC.

DRAWN BY: K. MALUSIC	DATE: 8/1/18	TITLE: SCHEMATIC DIAGRAM GAB00 CONFIGURED TYPE 1 NORMAL DUTY RATING WITH OPTION TV AND PH
CHECKED: N. LAWS	DATE: 8/1/18	SIZE: D
APPROVED: K. FLIERL	DATE: 8/1/18	REVISION: 03
ORIGINAL DESIGN: K. MALUSIC	DATE: 8/1/18	PAGE: 1 of 2

DRAWING # **DS.G8C1.15**

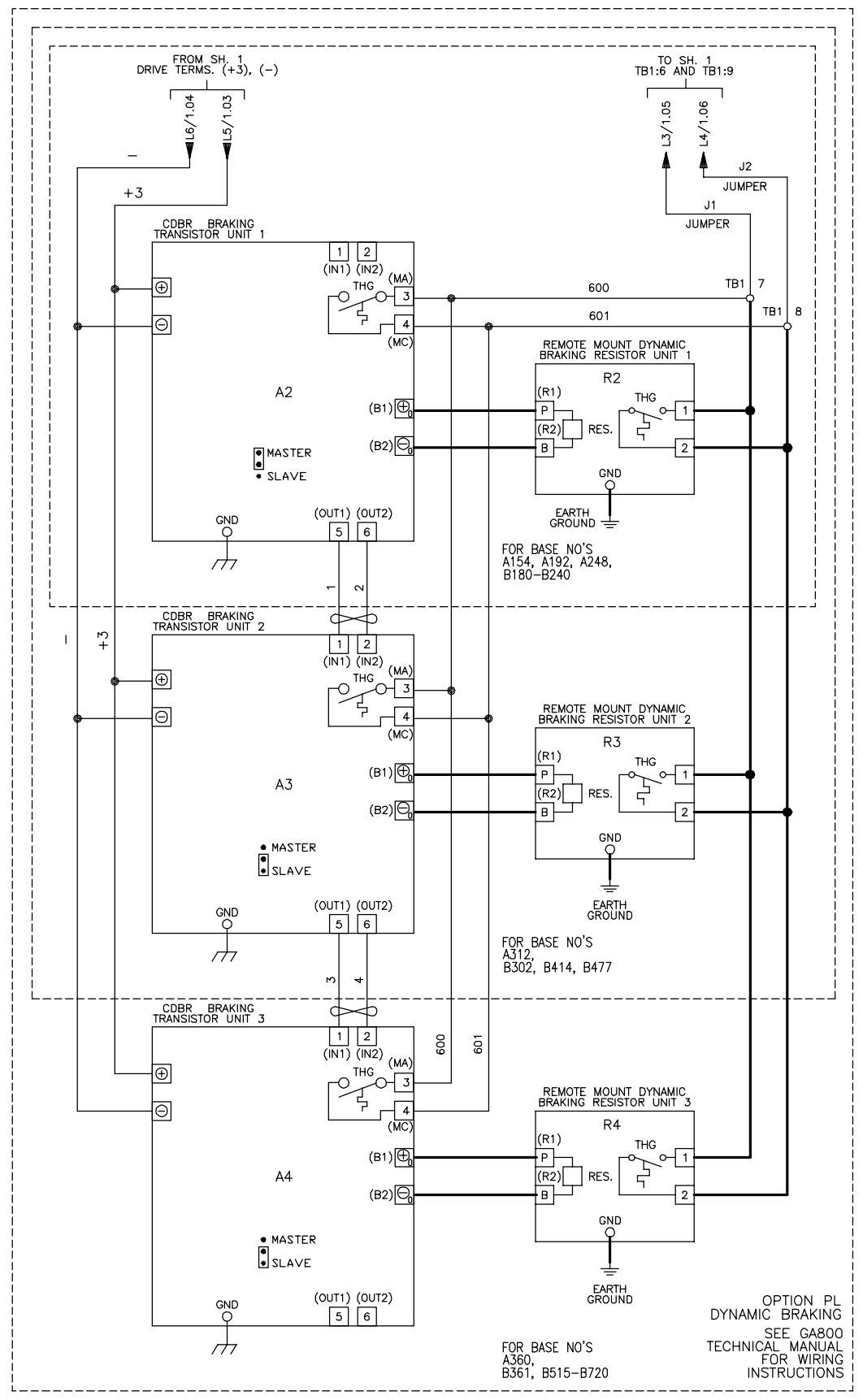

— INDICATES CUSTOMER WIRING.
 - CONNECTED TO THE CABINET OR PANEL.

NOTES:

- CONNECTED TO THE CABINET. CUSTOMER TO CONNECT THE CABINET GROUND LUG TO EARTH GROUND.
- CONDUIT FITTINGS/HUBS SHALL COMPLY WITH THE 'STANDARD FOR CONDUIT, TUBING, AND CABLE FITTINGS, UL 514B', OR CONDUIT FITTINGS HAVING THE SAME ENVIRONMENTAL RATING AS THE ENCLOSURE SHALL BE USED.
- WITHOUT THE CIRCUIT BREAKER (OPTION PC, PE OR PM), OR DISCONNECT SWITCH OPTION PD, THE DISCONNECT MEANS MUST BE SUPPLIED BY THE CUSTOMER.
- BRANCH CIRCUIT PROTECTION TO BE SUPPLIED BY THE CUSTOMER WHEN NOTED ON THE CABINET DATA NAMEPLATE.
- INSULATED TWISTED SHIELDED WIRE IS REQUIRED. SHIELD TO CONNECT TO PROPER TERMINALS AS SHOWN. CONNECT THE SHIELD ONLY AT THIS END. STUB AND ISOLATE THE OTHER END. DO NOT RUN THESE WIRES IN THE SAME CONDUIT AS THE AC POWER AND AC CONTROL WIRES. KEEP ALL WIRING UNDER 50m IN LENGTH.
- FOR A CONTROL TRANSFORMER T1 POWER RATING OF 350VA OR GREATER, SECONDARY FUSE F6 IS ADDED.
- IF AC MOTOR IS FURNISHED WITH A N.C. THERMAL SWITCH THEN SET DRIVE PARAMETER H1-08 TO 27. THIS WILL CAUSE THE DRIVE TO COAST TO STOP UPON A AC MOTOR THERMAL FAULT. ALONG WITH THIS, ADD THE FOLLOWING CUSTOMER WIRING: WIRE THE N.C. THERMAL SWITCH BETWEEN TERMINAL S8 OF THE 120VAC INTERFACE CARD AND ONE SIDE OF THE 120VAC SOURCE.
- CUSTOMER MUST PROVIDE PROPER SHORT CIRCUIT PROTECTION AND MEANS OF DISCONNECT.
- OPTIONS TC, TD, TG, TH OR TQ CONTROL (SEE UDE00579 FOR MORE INFORMATION):
 OPTION TC = PROFINET
 OPTION TD = ETHERNET/IP
 OPTION TG = DEVICENET
 OPTION TH = PROFIBUS
 OPTION TQ = ETHERNET MODBUS TCP/IP
- DRIVE INPUT FUSES F3, F4, F5 ARE INCLUDED WITH OPTION PE, PC, PM OR PJ FOR BASE NUMBERS B007-B302.
- DRIVE INPUT FUSES F3, F4, F5 ARE INCLUDED WITH OPTION TB FOR BASE NUMBERS A004-A009 AND B002-B007.
- DRIVE INPUT FUSES F3, F4, F5 ARE INCLUDED FOR BASE NUMBERS B361-B720.

REVISIONS				THIS DOCUMENT AND INFORMATION CONTAINED IN IT ARE CONFIDENTIAL, AND CANNOT BE COPIED OR DISCLOSED IN WHOLE OR IN PART WITHOUT THE EXPRESS WRITTEN CONSENT OF YASKAWA AMERICA INC.		
REV	DESCRIPTION	ECD #	DRAWN BY	DATE	DATE	DATE
03	ADDED INPUT FUSES TO B361-B720, NOTE 12	11302	KM	4/13/21	8/1/18	8/1/18
02	ADDED OPTION TB	10925	KAP	10/23/20	8/1/18	8/1/18

DRAWN BY:	K. MALUSIC	DATE:	8/1/18	TITLE:	SCHEMATIC DIAGRAM GA800 CONFIGURED TYPE 1 NORMAL DUTY RATING WITH OPTION TV AND PH
CHECKED:	N. LAWS	DATE:	8/1/18	APPROVED:	K. FLIERL
TECH:		DATE:		ORIGINAL DESIGN:	K. MALUSIC
DATE:		DATE:	8/1/18	DATE:	8/1/18
SIZE:	D	REVISION:	03	PAGE:	2 of 2
				DRAWING #:	DS.G8C1.15