

\* - INDICATES COMPONENTS NOT SUPPLIED BY YASKAWA.  
 --- - INDICATES CUSTOMER WIRING.  
 ⊕ - CONNECTED TO THE CABINET OR PANEL.

- NOTES:
- FACTORY CONNECTION POINT ON DRIVE A1.
  - 1. CONNECTED TO THE CABINET. CUSTOMER TO CONNECT THE CABINET GROUND LUGS TO EARTH GROUND AND UTILITY GROUND.
  - 2. CONDUIT FITTINGS/HUBS SHALL COMPLY WITH THE 'STANDARD FOR CONDUIT, TUBING AND CABLE FITTINGS, UL514B', OR CONDUIT FITTINGS HAVING THE SAME ENVIRONMENTAL RATING AS THE ENCLOSURE SHALL BE USED.
  - 3. INSULATED TWISTED SHIELDED WIRE IS REQUIRED. SHIELD TO CONNECT TO PROPER TERMINALS AS SHOWN. CONNECT THE SHIELD ONLY AT THIS END. STUB AND ISOLATE THE OTHER END. DO NOT RUN THESE WIRES IN THE THE SAME CONDUIT AS THE AC POWER AND AC CONTROL WIRES. KEEP ALL WIRING UNDER 50 METERS IN LENGTH.
  - 4. FOR A CONTROL TRANSFORMER T1 POWER RATING OF 350VA OR GREATER, SECONDARY FUSE F6 IS ADDED.
  - 5. THE MOTOR OVERLOAD RELAY IS FACTORY SET FOR MANUAL RESET. CUSTOMER TO ADJUST THE MOTOR OVERLOAD RELAY TRIP SETTING FOR THE ACTUAL AC MOTOR'S FULL LOAD AMPS.
  - 6. REMOVE THE JUMPER AND INSERT A NORMALLY CLOSED EXTERNAL FAULT CONTACT, IF REQUIRED.
  - 7. CUSTOMER TO ADJUST THE THERMOSTAT ON THE SPACE HEATER HR1 FOR THE MINIMUM DESIRED TEMPERATURE INSIDE THE DRIVE CABINET. THIS SET TEMPERATURE IS NORMALLY SELECTED TO BE SLIGHTLY HIGHER THAN THE MINIMUM AMBIENT TEMPERATURE OF THE AIR SURROUNDING THE CABINET, AND IS THE TEMPERATURE AT WHICH THE SPACE HEATER HR1 WILL SHUT OFF.

|                |  |                               |                  |  |
|----------------|--|-------------------------------|------------------|--|
| <b>YASKAWA</b> |  | DRAWN BY<br>K. MALUSIC        | DATE<br>04/20/26 | TITLE<br>SCHEMATIC DIAGRAM<br>IQPUMP1000 BYPASS<br>TYPE 3R |
|                |  | CHECKED BY<br>K. PEOPLES      | DATE<br>04/20/26 |  |
|                |  | APPROVED BY<br>R. JENSEN      | DATE<br>04/20/26 | SIZE<br>D  |
|                |  | ORIGINAL DESIGN<br>K. MALUSIC | DATE<br>04/20/26 | REVISION<br>00   |
|                |  |                               |                  | PAGE<br>1 of 2   |
|                |  |                               |                  | DRAWING #<br>DS.Q1B.3R.07                                  |

| REV. | DESCRIPTION     | ECO # | DRAWN BY | DATE     |
|------|-----------------|-------|----------|----------|
| 00   | INITIAL RELEASE | -     | KM       | 04/20/26 |

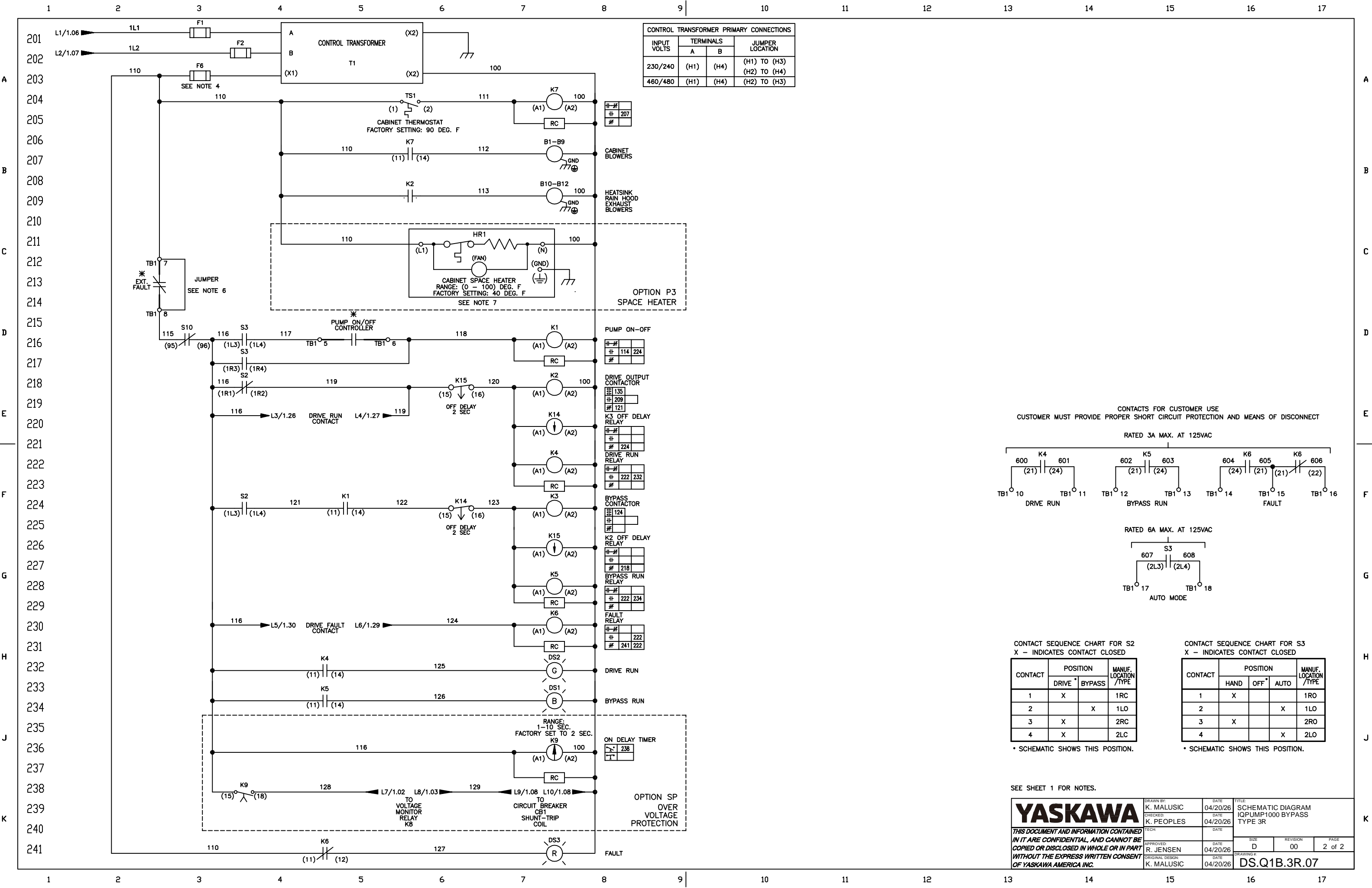

| INPUT VOLTS | TERMINALS |      | JUMPER LOCATION              |
|-------------|-----------|------|------------------------------|
|             | A         | B    |                              |
| 230/240     | (H1)      | (H4) | (H1) TO (H3)<br>(H2) TO (H4) |
| 460/480     | (H1)      | (H4) | (H2) TO (H3)                 |

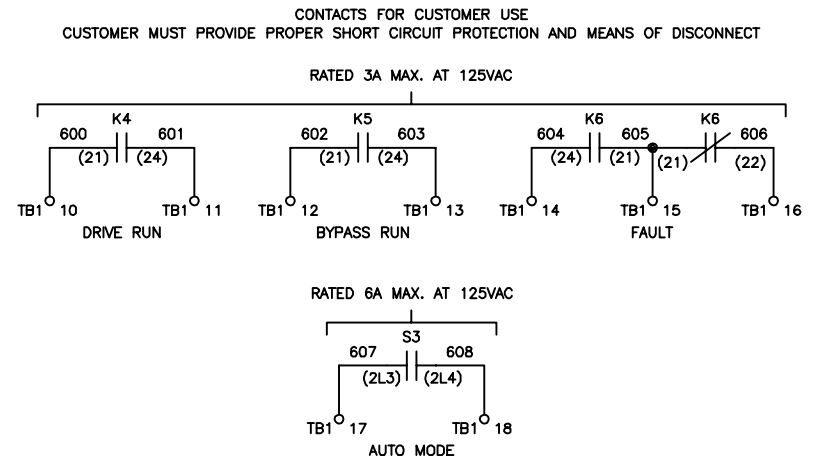

CONTACT SEQUENCE CHART FOR S2  
X - INDICATES CONTACT CLOSED

| CONTACT | POSITION |        | MANUF. LOCATION /TYPE |
|---------|----------|--------|-----------------------|
|         | DRIVE    | BYPASS |                       |
| 1       | X        |        | 1RC                   |
| 2       |          | X      | 1LO                   |
| 3       | X        |        | 2RC                   |
| 4       | X        |        | 2LC                   |

\* SCHEMATIC SHOWS THIS POSITION.

CONTACT SEQUENCE CHART FOR S3  
X - INDICATES CONTACT CLOSED

| CONTACT | POSITION |     |      | MANUF. LOCATION /TYPE |
|---------|----------|-----|------|-----------------------|
|         | HAND     | OFF | AUTO |                       |
| 1       | X        |     |      | 1RO                   |
| 2       |          |     | X    | 1LO                   |
| 3       | X        |     |      | 2RO                   |
| 4       |          |     | X    | 2LO                   |

\* SCHEMATIC SHOWS THIS POSITION.

SEE SHEET 1 FOR NOTES.

|                             |                      |                |  |              |              |
|-----------------------------|----------------------|----------------|--|--------------|--------------|
| <b>YASKAWA</b>              | DRAWN BY: K. MALUSIC | DATE: 04/20/26 | TITLE: SCHEMATIC DIAGRAM IQPUMP1000 BYPASS TYPE 3R |              |              |
|                             | CHECKED: K. PEOPLES  | DATE: 04/20/26 | SIZE: D  | REVISION: 00 | PAGE: 2 of 2 |
| APPROVED: R. JENSEN         |                      | DATE: 04/20/26 | DRAWING #: DS.Q1B.3R.07                            |              |              |
| ORIGINAL DESIGN: K. MALUSIC |                      | DATE: 04/20/26 |  |              |              |