

- NOTES:
- CONNECTED TO THE CABINET. CUSTOMER TO CONNECT THE CABINET GROUND LUGS TO EARTH GROUND AND UTILITY GROUND.
 - INSULATED TWISTED SHIELDED WIRE IS REQUIRED. SHIELD TO CONNECT TO PROPER TERMINAL AS SHOWN. CONNECT THE SHIELD ONLY AT THIS END. STUB AND ISOLATE THE OTHER END. DO NOT RUN THESE WIRES IN THE SAME CONDUIT AS THE AC POWER AND THE AC CONTROL WIRES. KEEP ALL WIRING UNDER 50m IN LENGTH.
 - WITH A CONTROL TRANSFORMER, T1, POWER RATING 350VA OR GREATER, SECONDARY FUSE F6 IS ADDED.
 - WITHOUT THE INPUT CIRCUIT BREAKER OPTION PC, OR WHEN NOTED ON THE CABINET NAMEPLATE, BRANCH CIRCUIT PROTECTION MUST BE SUPPLIED BY THE INSTALLER.
 - CUSTOMER TO ADJUST THE THERMOSTAT ON THE SPACE HEATER HR1 FOR THE MINIMUM DESIRED TEMPERATURE INSIDE THE DRIVE CABINET. THIS SET TEMPERATURE IS NORMALLY SELECTED TO BE SLIGHTLY HIGHER THAN THE MINIMUM AMBIENT TEMPERATURE OF THE AIR SURROUNDING THE CABINET AND IS THE TEMPERATURE AT WHICH THE SPACE HEATER HR1 WILL SHUT OFF.
 - CONDUIT FITTINGS/HUBS SHALL COMPLY WITH THE 'STANDARD FOR CONDUIT, TUBING, AND CABLE FITTINGS, UL 514B' OR CONDUIT FITTINGS HAVING THE SAME ENVIRONMENTAL RATING AS THE ENCLOSURE SHALL BE USED.
 - TERMINALS p1 AND n1 ARE FOR MOMENTARY POWER LOSS RECOVERY UNIT. DO NOT CONNECT TO AC POWER SUPPLY.
 - CUSTOMER TO REPLACE THE JUMPER WITH NORMALLY CLOSED SAFETY INTERLOCKS, IF APPLICABLE.

— - INDICATES COMPONENTS NOT SUPPLIED BY YASKAWA
 * - INDICATES CUSTOMER WIRING
 ⚡ - CONNECTED TO THE CABINET OR PANEL

SEE DRAWING UDE00538 FOR DRIVE PARAMETERS.
 SEE DRAWING UDE00539 FOR CUSTOMER CONNECTIONS.

YASKAWA		DRAWN BY: A. MEILAHN	DATE: 01/05/17	TITLE: SCHEMATIC DIAGRAM U1000 IQPUMP CONFIGURED TYPE 3R, 480V
		CHECKED BY: N. LAWS	DATE: 02/10/17	
		TECH: K. FLIERL	DATE: 02/15/17	
		APPROVED BY: A. MEILAHN	DATE: 01/05/17	
		DESIGNER: A. MEILAHN	DATE: 01/05/17	

REVISIONS				
REV.	DESCRIPTION	ECO #	DRAWN BY	DATE
03	ADDED TB5 TO DRIVE	11178	N. LAWS	05/03/21
02	UPDATED DRIVE BLOCK AND SPEED POT	11109	N. LAWS	01/29/21

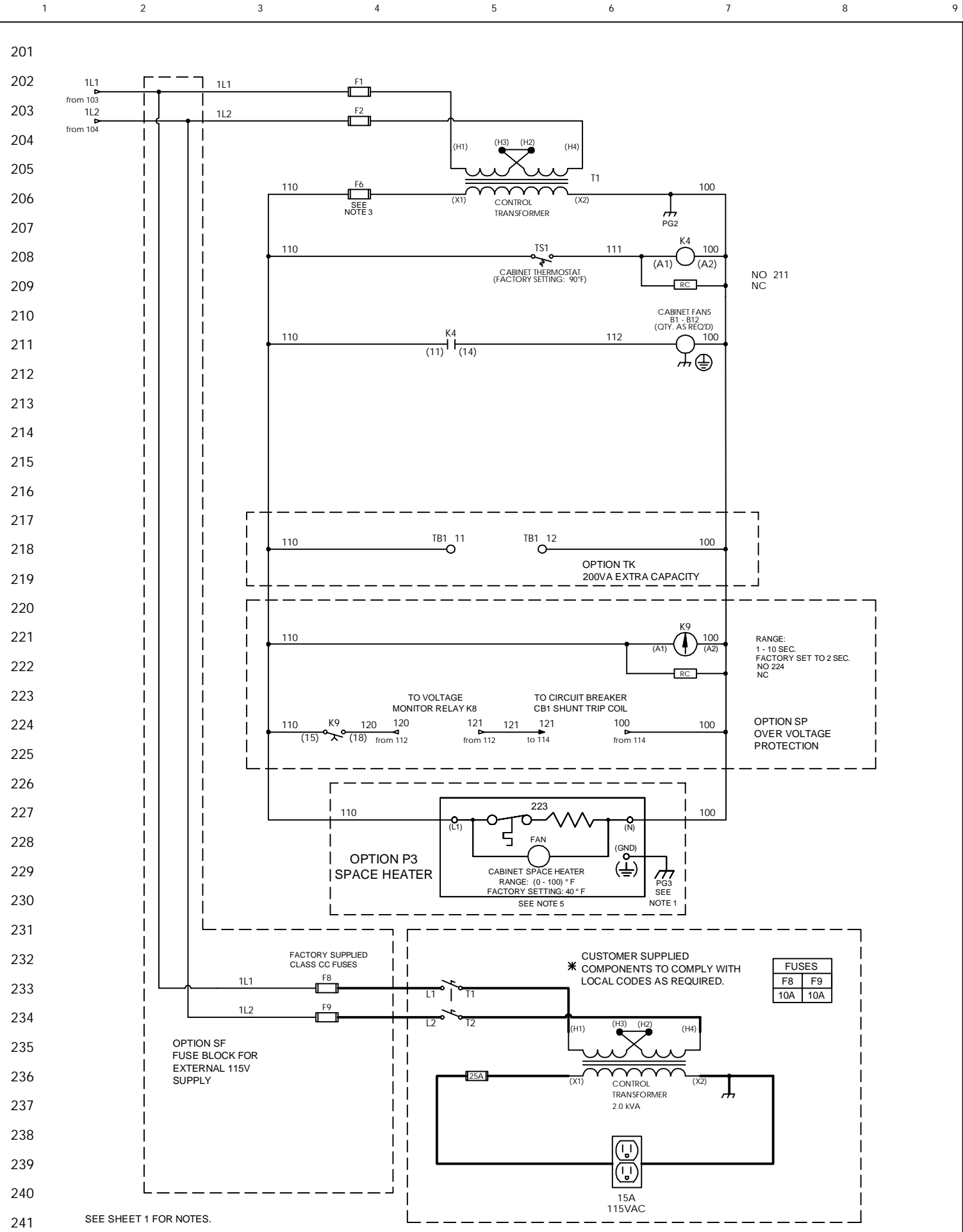

RUN/STOP CONTROL (FROM SHEET 1)

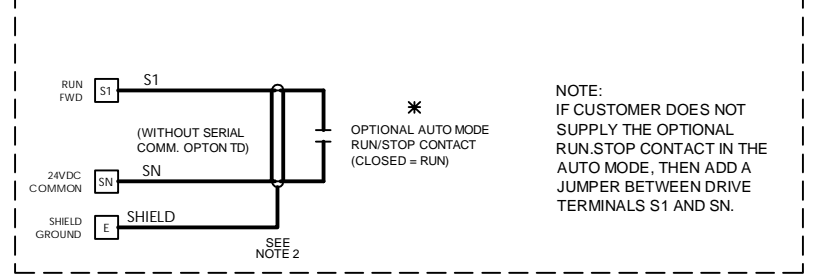

OR

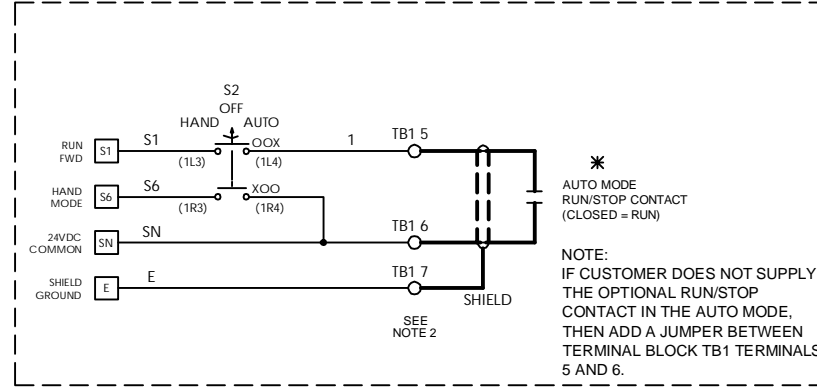

CONTACT SEQUENCE CHART FOR S2
X - INDICATES CONTACT CLOSED

CONTACT	POSITION			MANUF. LOCATION /TYPE
	HAND	OFF	AUTO	
1	X			1RO
2			X	1LO

SCHMATIC SHOWS THIS POSITION.

OR

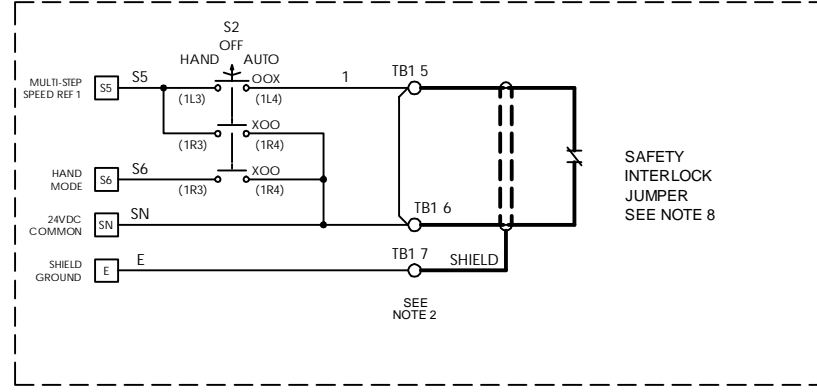

CONTACT SEQUENCE CHART FOR S2
X - INDICATES CONTACT CLOSED

CONTACT	POSITION			MANUF. LOCATION /TYPE
	HAND	OFF	AUTO	
1	X			1RO
2			X	1LO
3	X			2RO

SCHMATIC SHOWS THIS POSITION.

YASKAWA

DRAWN BY:	A. MEILAHN	DATE:	01/05/17	TITLE:	SCHEMATIC DIAGRAM
CHECKED:	N. LAWS	DATE:	02/10/17		U1000 IQPUMP CONFIGURED
TECH:		DATE:			TYPE 3R, 480V
APPROVED:	K. FLIERL	DATE:	02/15/17	SIZE:	D
ORIGINAL DESIGN:	A. MEILAHN	DATE:	01/05/17	REVISION:	03
				PAGE:	2 of 2

THIS DOCUMENT AND INFORMATION CONTAINED IN IT ARE CONFIDENTIAL, AND CANNOT BE COPIED OR DISCLOSED IN WHOLE OR IN PART WITHOUT THE EXPRESS WRITTEN CONSENT OF YASKAWA AMERICA INC.

DS.Q1E3.02