

- NOTES:
- CONNECTED TO THE CABINET. CUSTOMER TO CONNECT THE CABINET GROUND LUGS TO EARTH GROUND AND UTILITY GROUND.
 - INSULATED TWISTED SHIELDED WIRE IS REQUIRED. SHIELD TO CONNECT TO PROPER TERMINAL AS SHOWN. CONNECT THE SHIELD ONLY AT THIS END. STUB AND ISOLATE THE OTHER END. DO NOT RUN THESE WIRES IN THE SAME CONDUIT AS THE AC POWER AND THE AC CONTROL WIRES. KEEP ALL WIRING UNDER 50m IN LENGTH.
 - WITH A CONTROL TRANSFORMER, T1, POWER RATING 350VA OR GREATER, SECONDARY FUSE RATED: 1A, 250VAC
1A, 30VDC
CUSTOMER MUST PROVIDE PROPER SHORT CIRCUIT PROTECTION AND MEANS OF DISCONNECT .
 - WITHOUT THE INPUT CIRCUIT BREAKER OPTION PC, OR WHEN NOTED ON THE CABINET NAMEPLATE, BRANCH CIRCUIT PROTECTION MUST BE SUPPLIED BY THE INSTALLER.
 - CUSTOMER TO ADJUST THE THERMOSTAT ON THE SPACE HEATER HR1 FOR THE MINIMUM DESIRED TEMPERATURE INSIDE THE DRIVE CABINET. THIS SET TEMPERATURE IS NORMALLY SELECTED TO BE SLIGHTLY HIGHER THAN THE MINIMUM AMBIENT TEMPERATURE OF THE AIR SURROUNDING THE CABINET AND IS THE TEMPERATURE AT WHICH THE SPACE HEATER HR1 WILL SHUT OFF.
 - CONDUIT FITTINGS/HUBS SHALL COMPLY WITH THE 'STANDARD FOR CONDUIT, TUBING, AND CABLE FITTINGS, UL 514B' OR CONDUIT FITTINGS HAVING THE SAME ENVIRONMENTAL RATING AS THE ENCLOSURE SHALL BE USED.
 - TERMINALS p1 AND n1 ARE FOR MOMENTARY POWER LOSS RECOVERY UNIT. DO NOT CONNECT TO AC POWER SUPPLY.
 - CUSTOMER TO REPLACE THE JUMPER WITH NORMALLY CLOSED SAFETY INTERLOCKS, IF APPLICABLE.

— - INDICATES COMPONENTS NOT SUPPLIED BY YASKAWA
 * - INDICATES CUSTOMER WIRING
 ⚡ - CONNECTED TO THE CABINET OR PANEL

SEE DRAWING UDE00538 FOR DRIVE PARAMETERS.
 SEE DRAWING UDE00539 FOR CUSTOMER CONNECTIONS.

YASKAWA		DRAWN BY A. MEILAHN	DATE 01/05/17	TITLE SCHEMATIC DIAGRAM U1000 IQPUMP CONFIGURED TYPE 3R, 240V
		CHECKED BY N. LAWS	DATE 02/10/17	
		TECH	DATE	
		APPROVED BY K. FLIERL	DATE 02/15/17	SIZE D
		ORIGINAL DESIGNER A. MEILAHN	DATE 01/05/17	REVISION 03
				PAGE 1 of 2
				DRAWING #: DS.Q1E3.07

REV.	DESCRIPTION	ECO #	DRAWN BY	DATE
03	ADDED TB5 TO DRIVE	11178	N. LAWS	05/03/21
02	UPDATED DRIVE BLOCK AND SPEED POT	11109	N. LAWS	01/29/21

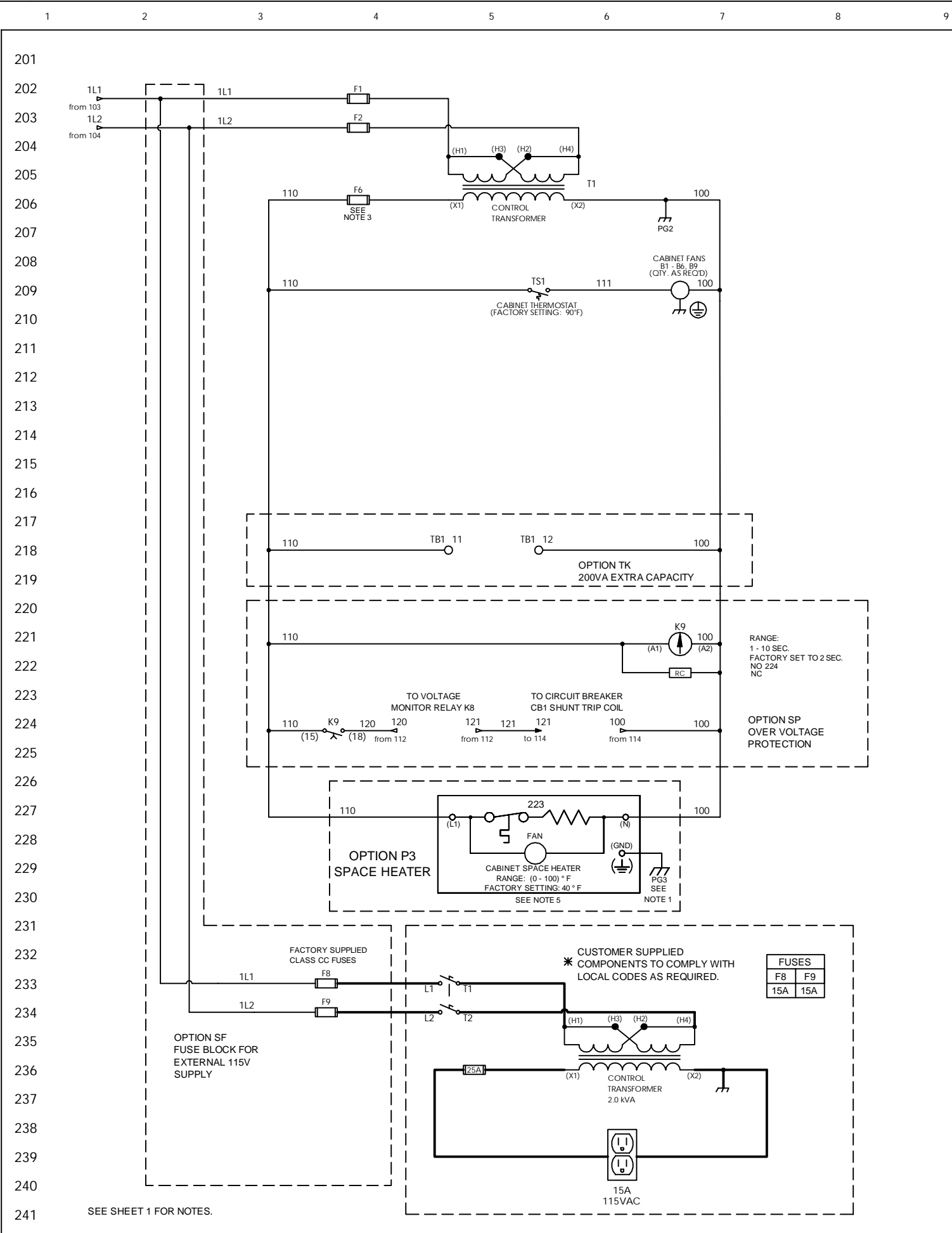

RUN/STOP CONTROL (FROM SHEET 1)

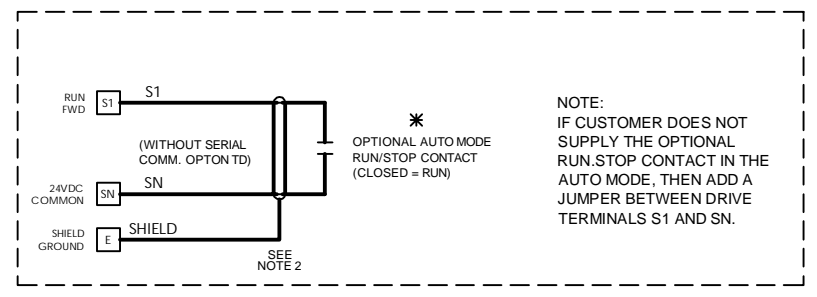

OR

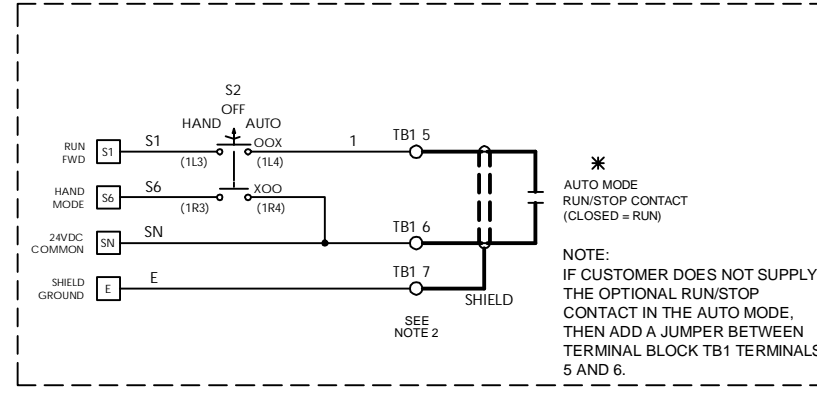

CONTACT SEQUENCE CHART FOR S2
X - INDICATES CONTACT CLOSED

CONTACT	POSITION			MANUF. LOCATION /TYPE
	HAND	OFF	AUTO	
1	X			1RO
2			X	1LO

SCHMATIC SHOWS THIS POSITION.

OPTION TY,
AND WITHOUT
OPTION TD SERIAL
COMMUNICATION

OR

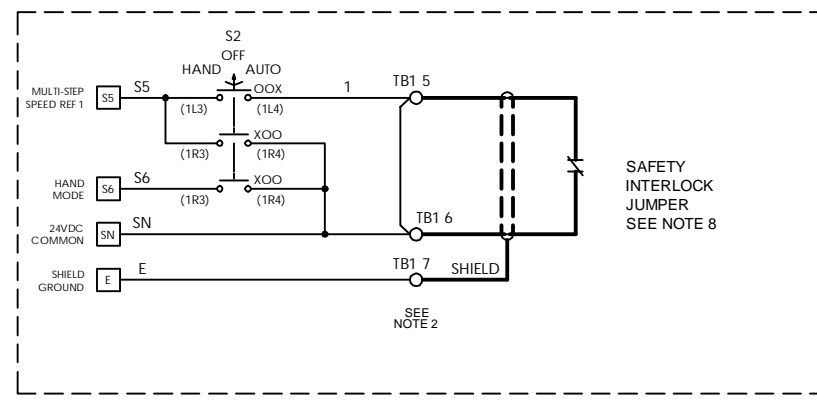

CONTACT SEQUENCE CHART FOR S2
X - INDICATES CONTACT CLOSED

CONTACT	POSITION			MANUF. LOCATION /TYPE
	HAND	OFF	AUTO	
1	X			1RO
2			X	1LO
3	X			2RO

SCHMATIC SHOWS THIS POSITION.

OPTION TY,
AND WITH
OPTION TD SERIAL
COMMUNICATION

YASKAWA	DRAWN BY:	A. MEILAHN	DATE:	01/05/17	TITLE:	SCHEMATIC DIAGRAM				
	CHECKED:	N. LAWS	DATE:	02/10/17		U1000 IQPUMP CONFIGURED TYPE 3R, 240V				
THIS DOCUMENT AND INFORMATION CONTAINED HEREIN ARE CONFIDENTIAL AND CANNOT BE COPIED OR DISCLOSED IN WHOLE OR IN PART WITHOUT THE EXPRESS WRITTEN CONSENT OF YASKAWA AMERICA, INC.	TECH:		DATE:		SIZE:	D	REVISION:	03	PAGE:	2 of 2
	APPROVED:	K. FLIERL	DATE:	02/13/17	DRAWING #:					
	ORIGINAL DESIGN:	A. MEILAHN	DATE:	01/05/17	DS.Q1E3.07					