

CONTROL TRANSFORMER PRIMARY CONNECTIONS

INPUT VOLTS	TERMINALS	JUMPER LOCATION
208	(H1) (H2)	NONE
480/490	(H1) (H4) (H2) TO (H3)	

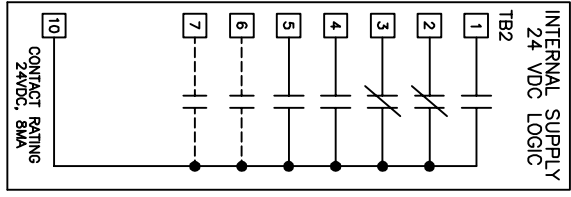

REV.	DESCRIPTION	ECO #	DRAWN BY	DATE
03	CHANGE REF NUMBERS 101-141 TO 201-241 ON PAGE 2	6330	DJP	6/12/15
02	ADDED DASHED LINE AROUND AB	4453	K. MALUSIC	8/13/13
01	CHANGED WIRE NUMBERS	4315	K. MALUSIC	7/1/13

DATE	TITLE
4/23/13	SCHEMATIC DIAGRAM BYPASS
4/23/13	Z1000 ELECTRONIC AND
4/23/13	2-MTR OPTION PA
4/23/13	DRIVING #
4/23/13	OPTION PA
4/23/13	DRIVING #
4/23/13	OPTION PA

DESIGNED BY	DATE	DESIGNED BY	DATE
K. MALUSIC	4/23/13	K. MALUSIC	4/23/13
D.R. CMEJAK	4/23/13	D.R. CMEJAK	4/23/13
K. FLIERL	4/23/13	K. FLIERL	4/23/13
D.R. CMEJAK	4/23/13	D.R. CMEJAK	4/23/13

SIZE	REGION	PAGE
D	03	1 of 2

* - INDICATES COMPONENTS NOT SUPPLIED BY YASKAWA.
 --- INDICATES CUSTOMER WIRING.
 --- CONNECTED TO THE CABINET OR PANEL.
 --- SEE SHEET 2 FOR NOTES.

- NOTES:
1. CUSTOMER TO CONNECT THE CABINET GROUND LUGS TO EARTH GROUND AND UTILITY GROUND.
 2. CONDUIT FITTINGS/HUBS SHALL COMPLY WITH THE 'STANDARD FOR CONDUIT, TUBING, AND CABLE FITTINGS, UL 514B'. OR CONDUIT FITTINGS HAVING THE SAME ENVIRONMENTAL RATING AS THE ENCLOSURE SHALL BE USED.
 3. INSULATED TWISTED SHIELDED WIRE IS REQUIRED. SHIELD TO CONNECT TO PROPER TERMINAL AS SHOWN. CONNECT THE SHIELD ONLY AT THIS END. STUB AND ISOLATE THE OTHER END. DO NOT RUN THESE WIRES IN THE SAME CONDUIT AS THE AC POWER AND THE AC CONTROL WIRES.
 4. WITH A CONTROL TRANSFORMER, T1, POWER RATING 350VA OR GREATER, SECONDARY FUSE F6 IS ADDED.
 5. CHANGING Z1-01 TO "1" WILL PROGRAM THE DRIVE AND BYPASS PARAMETERS TO THEIR FACTORY DEFAULT SETTINGS.
 6. FOR 208VAC APPLICATIONS, SET E1-01 TO 208, AND SET E1-05 TO 208.
 7. THE MOTOR OVERLOAD RELAY IS FACTORY SET FOR MANUAL RESET. CUSTOMER TO ADJUST THE MOTOR OVERLOAD RELAY TRIP SETTING FOR THE ACTUAL AC MOTOR'S FULL LOAD AMPS.
 8. CUSTOMER TO ADJUST THE THERMOSTAT ON THE SPACE HEATER HR1 FOR THE MINIMUM DESIRED TEMPERATURE INSIDE THE DRIVE CABINET. THIS SET TEMPERATURE IS NORMALLY SELECTED TO BE SLIGHTLY HIGHER THAN THE MINIMUM AMBIENT TEMPERATURE OF THE AIR SURROUNDING THE CABINET. AND IS THE TEMPERATURE AT WHICH THE SPACE HEATER HR1 WILL SHUT OFF.

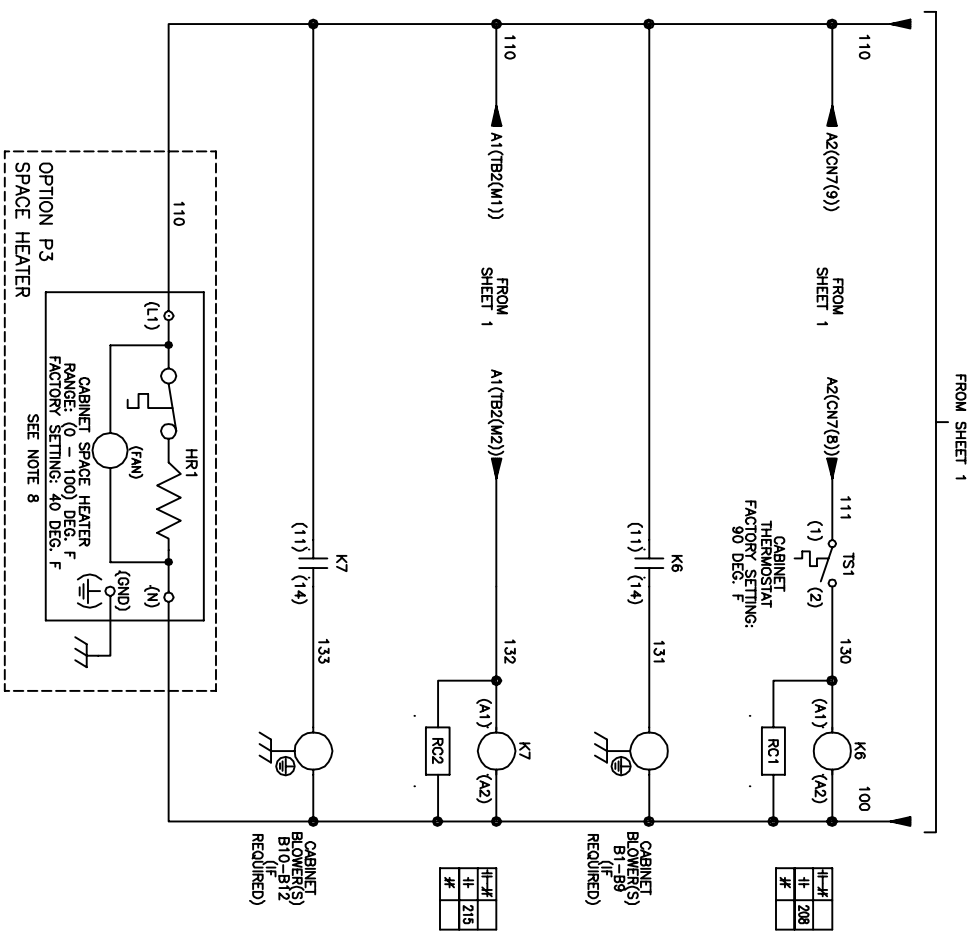

201
202
203
204
205
206
207
208
209
210
211
212
213
214
215
216
217
218
219
220
221
222
223
224
225
226
227
228
229
230
231
232
233
234
235
236
237
238
239
240
241

YASKAWA		DRAWN BY: K. MALUSIC		DATE: 4/23/13	TITLE: SCHEMATIC DIAGRAM
CHECKED: D. CMEIAK		APPROVED: K. FLIERL		DATE: 4/23/13	2-1000 ELECTRONIC BYPASS
DESIGNED: D.R. CMEIAK		DATE: 4/23/13		OPTION PA	2 of 2
THIS DOCUMENT AND INFORMATION CONTAINED HEREIN IS UNCLASSIFIED EXCEPT WHERE SHOWN OTHERWISE. IT IS THE PROPERTY OF YASKAWA AMERICA INC. AND IS LOANED TO YOUR COMPANY. IT IS NOT TO BE REPRODUCED OR TRANSMITTED IN ANY FORM OR BY ANY MEANS, ELECTRONIC OR MECHANICAL, INCLUDING PHOTOCOPYING, RECORDING, OR BY ANY INFORMATION STORAGE AND RETRIEVAL SYSTEM, WITHOUT THE EXPRESS WRITTEN CONSENT OF YASKAWA AMERICA INC.					