

Machine Controller MP900/MP2000 Series

Distributed I/O Module

USER'S MANUAL

MECHATROLINK System

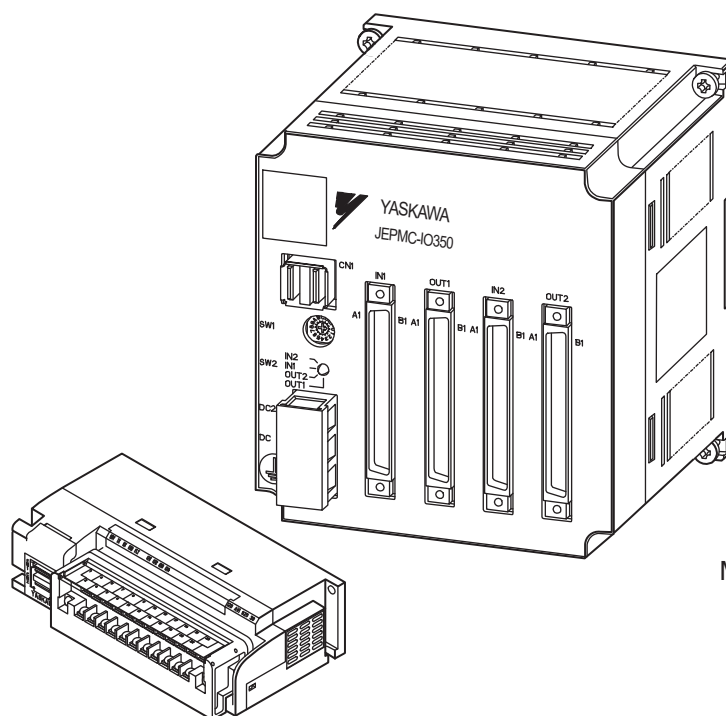

System Overview	1
I/O Allocations	2
Distributed I/O Module	3
Other I/O Modules	4
Reversible Counter Module with Preset Function	5
Pulse Output Module	6
PLC Module	7
MECHATROLINK-II Repeater	8
Connections	9
App	

Copyright © 2000 YASKAWA ELECTRIC CORPORATION

All rights reserved. No part of this publication may be reproduced, stored in a retrieval system, or transmitted, in any form, or by any means, mechanical, electronic, photocopying, recording, or otherwise, without the prior written permission of Yaskawa. No patent liability is assumed with respect to the use of the information contained herein. Moreover, because Yaskawa is constantly striving to improve its high-quality products, the information contained in this manual is subject to change without notice. Every precaution has been taken in the preparation of this manual. Nevertheless, Yaskawa assumes no responsibility for errors or omissions. Neither is any liability assumed for damages resulting from the use of the information contained in this publication.

Using this Manual

Please read this manual to ensure correct usage of the MECHATROLINK system. Keep this manual in a safe place for future reference.

■ Basic Terms

Unless otherwise specified, the following definitions are used:

- MECHATROLINK : Generic term for Motion Network MECHATROLINK-I and MECHATROLINK-II
- M-I : MECHATROLINK-I
- M-II : MECHATROLINK-II
- PC : Programmable Logic Controller
- MPE720: The Programming Device Software or a Programming Device (i.e., a personal computer) running the Programming Device Software

■ Manual Configuration

Read the chapters of this manual as required by the purpose.

Chapter	Selecting Models and Peripheral Devices	Studying Specifications and Ratings	Designing the System	Installation and Wiring	Trial Operation	Maintenance and Inspection
Chapter 1 System Overview	Applicable	–	Applicable	Applicable	Applicable	–
Chapter 2 I/O Allocations	–	–	Applicable	Applicable	Applicable	–
Chapter 3 Distributed I/O Modules	Applicable	Applicable	Applicable	Applicable	Applicable	Applicable
Chapter 4 Other I/O Modules	Applicable	Applicable	Applicable	Applicable	Applicable	Applicable
Chapter 5 Reversible Counter Module with Preset Function	Applicable	Applicable	Applicable	Applicable	Applicable	Applicable
Chapter 6 Pulse Output Module	Applicable	Applicable	Applicable	Applicable	Applicable	Applicable
Chapter 7 PLC Module	Applicable	Applicable	Applicable	Applicable	Applicable	Applicable
Chapter 8 MECHATROLINK-II Repeater	Applicable	Applicable	Applicable	Applicable	Applicable	Applicable
Chapter 9 Connections	–	–	Applicable	Applicable	Applicable	Applicable
Appendices	–	–	Applicable	Applicable	–	–

■ Visual Aids

The following aids are used to indicate certain types of information for easier reference.



Indicates important information that should be memorized.



Indicates supplemental information.



Indicates application examples.



Describes technical terms that are difficult to understand, or appear in the text without an explanation being given.

■ Indication of Reverse Signals

In this manual, the names of reverse signals (ones that are valid when low) are written with a forward slash (/) before the signal name, as shown in the following example:

- $\overline{\text{S-ON}}$ = /S-ON
- $\overline{\text{P-CON}}$ = / $\overline{\text{P-CON}}$

■ Related Manuals

Refer to the following related manuals as required.

Thoroughly check the specifications, restrictions, and other conditions of the product before attempting to use it.

Manual Name	Manual Number	Contents
Machine Controller MP900 Series User's Manual Ladder Programming	SIEZ-C887-1.2	Describes the instructions used in MP900/ MP2000 ladder programming.
Machine Controller MP900/MP2000 Series User's Manual: MPE720 Software for Programming Device	SIEP C880700 05	Describes how to install and operate the MP900/MP2000 Series programming sys- tem (MPE720).
Machine Controller MP920 User's Manual Motion Module	SIEZ-C887-2.5	Describes the functions, specifications, and application methods of the MP920 Motion Modules (SVA-01, SVB-01, and PO-01).
Machine Controller MP910 User's Manual Design and Maintenance	SIEZ-C887-3.1	Describes the design and maintenance of the MP910 Machine Controller.
Machine Controller MP920 User's Manual Design and Maintenance	SIEZ-C887-2.1	Describes the design and maintenance of the MP920 Machine Controller.
Machine Controller MP930 User's Manual Design and Maintenance	SIEZ-C887-1.1	Describes the design and maintenance of the MP930 Machine Controller.
Machine Controller MP940 User's Manual Design and Maintenance	SIEZ-C887-4.1	Describes the design and maintenance of the MP940 Machine Controller.
Machine Controller MP2100 User's Manual Design and Maintenance	SIEP C880700 01	Describes the design and maintenance of the MP2100 Machine Controller.
Machine Controller MP2300 Basic Module User's Manual	SIEP C880700 03	Describes the design and maintenance of the MP2300 Basic Module.
FDS System Installation Manual	SIE-C873-16.4	Describes transmission line wiring methods.

Safety Information

The following conventions are used to indicate precautions in this manual. Failure to heed precautions provided in this manual can result in serious or possibly even fatal injury or damage to the products or to related equipment and systems.



Indicates precautions that, if not heeded, could possibly result in loss of life or serious injury.



Indicates precautions that, if not heeded, could result in relatively serious or minor injury, damage to the product, or faulty operation.

Safety Precautions

The following precautions are for checking products on delivery, storage, transportation, installation, wiring, operation, maintenance, inspection, and disposal. These precautions are important and must be observed.

WARNING

- Before starting operation in combination with the machine, ensure that an emergency stop procedure has been provided and is working correctly.
There is a risk of injury.
- Do not touch anything inside the MECHATROLINK devices.
There is a risk of electrical shock.
- Always keep the front cover attached when power is being supplied.
There is a risk of electrical shock.
- Observe all procedures and precautions given in this manual for trial operation.
Operating mistakes while the servomotor and machine are connected can cause damage to the machine or even accidents resulting in injury or death.
- Do not remove the front cover, cables, connector, or options while power is being supplied.
There is a risk of electrical shock.
-  Do not allow installation, disassembly, or repairs to be performed by anyone other than specified personnel.
There is a risk of electrical shock or injury.
- Do not damage, pull on, apply excessive force to, place heavy objects on, or pinch cables.
There is a risk of electrical shock, operational failure or burning of the Machine Controller.
- Do not attempt to modify the Machine Controller in any way.
There is a risk of injury or device damage.
- Do not approach the machine when there is a momentary interruption to the power supply. When power is restored, the machine may start operation suddenly. Provide suitable safety measures to protect people when operation restarts.
There is a risk of injury.

■ Storage and Transportation

CAUTION

- Do not store or install the Machine Controller in the following locations.
There is a risk of fire, electrical shock, or device damage.
 - Direct sunlight
 - Ambient temperature exceeds the storage or operating conditions
 - Ambient humidity exceeds the storage or operating conditions
 - Rapid changes in temperature or locations subject to condensation
 - Corrosive or flammable gas
 - Excessive dust, dirt, salt, or metallic powder
 - Water, oil, or chemicals
 - Vibration or shock
- Do not overload the Machine Controller during transportation.
There is a risk of injury or an accident.
- If disinfectants or insecticides must be used to treat packing materials such as wooden frames, pallets, or plywood, the packing materials must be treated before the product is packaged, and methods other than fumigation must be used.
Example: Heat treatment, where materials are kiln-dried to a core temperature of 56°C for 30 minutes or more.

If the electronic products, which include stand-alone products and products installed in machines, are packed with fumigated wooden materials, the electrical components may be greatly damaged by the gases or fumes resulting from the fumigation process. In particular, disinfectants containing halogen, which includes chlorine, fluorine, bromine, or iodine can contribute to the erosion of the capacitors.

■ Installation

CAUTION

- Never use the Machine Controller in locations subject to water, corrosive atmospheres, or flammable gas, or near burnable objects.
There is a risk of electrical shock or fire.
- Do not step on the Machine Controller or place heavy objects on the Machine Controller.
There is a risk of injury.
- Do not block the air exhaust port or allow foreign objects to enter the Machine Controller.
There is a risk of element deterioration inside, an accident, or fire.
- Always mount the Machine Controller in the specified orientation.
There is a risk of an accident.
- Do not subject the Machine Controller to strong shock.
There is a risk of an accident.
- Always install the Module in the specified orientation.
There is a risk of Module falling, damage, or malfunction.
- The ambient temperature is limited depending on the Module installation orientation. Use the Module under the restricted conditions.
There is a risk of an accident or malfunction.

■ Wiring

CAUTION

- Check the wiring to be sure it has been performed correctly.
There is a risk of motor run-away, injury, or an accident.
- Always use a power supply of the specified voltage.
There is a risk of burning.
- In places with poor power supply conditions, take all steps necessary to ensure that the input power supply is within the specified voltage range.
There is a risk of device damage.
- Install breakers and other safety measures to provide protection against shorts in external wiring.
There is a risk of fire.
- Provide sufficient shielding when using the Machine Controller in the following locations.
There is a risk of device damage.
 - Noise, such as from static electricity
 - Strong electromagnetic or magnetic fields
 - Radiation
 - Near power lines
- When connecting the battery, connect the polarity correctly.
There is a risk of battery damage or explosion.
- Built-in fuses do not protect the output elements. Connect a fuse appropriate for the load specifications in series with the load.
There is a risk of fire, damage to the load equipment, or damage to the output circuits if there is a load short-circuit or overload.
- The customer must not replace the built-in fuses.
There is a risk of output module accident or malfunction. Also any failures caused by ignoring this caution will invalidate the guarantee. Yaskawa replaces built-in fuses.
- When the external input pulse signal is 24 VDC, do not connect anything to “PHAn+” or “PHBn+” terminal.
There is a risk of input circuit damage.
- When the external input pulse signal is 12 VDC, connect a resistor of 22 k Ω (1/4w) between “PHAn” and “PHA+” terminals and between “PHBn” and “PHB+” terminals.
There is a risk of input circuit damage.
- When the external input pulse signal is 5 VDC, connect a resistor of 330 Ω (1/4w) between “PHAn” and “PHA+” terminals and between “PHBn” and “PHB+” terminals.
There is a risk of input circuit damage.
- When the external input pulse signal is of differential output voltage, do not connect anything to “PHAn” and “PHBn” terminals.
There is a risk of input circuit damage.
- To connect an induction load, connect the fly-wheel diode in parallel to the induction load to reduce surge voltage.
There is a risk of output circuit damage.
- Each Module is not protected against lightning surge. Do not employ overhead wiring.
There is a risk of device damage due to lightning.

■ Operations

⚠ CAUTION

- Connect a fuse appropriate for the load specifications in series with the load.
There is a risk of fire, damage to the load equipment, or damage to the output circuits if there is a load short-circuit or overload.
- Do not change the DIP switch settings while a Digital I/O Module is operating.
New settings on the Digital I/O Module's DIP switch become effective as soon as they are changed. Change the DIP switch settings only when the Module's main external power supply (24 VDC) is OFF. Changing the Module's DIP switch settings during operation may cause the Module to malfunction.

■ Selecting, Separating, and Laying External Cables

⚠ CAUTION

- Consider the following items when selecting the I/O signal lines (external cables) to connect the MECHATROLINK device to external devices.
 - Mechanical strength
 - Noise interference
 - Wiring distance
 - Signal voltage, etc.
- Separate the I/O signal lines from the power lines both inside and outside the control box to reduce the influence of noise from the power lines.
If the I/O signal lines and power lines are not separated properly, malfunctioning may result.

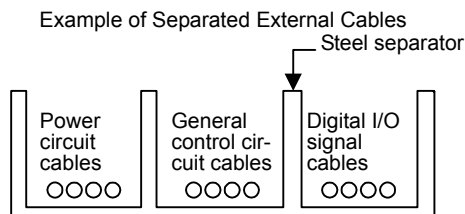

■ Maintenance and Inspection

⚠ CAUTION

- Do not attempt to disassemble the MECHATROLINK device.
There is a risk of electrical shock or injury.
- Do not change wiring while power is being supplied.
There is a risk of electrical shock or injury.
- When replacing the Machine Controller, restart operation only after transferring the programs and parameters from the old Machine Controller to the new Machine Controller.
There is a risk of device damage.

■ Disposal

⚠ CAUTION

- Dispose of the Machine Controller as general industrial waste.

■ General Precautions

Observe the following general precautions
to ensure safe application.

- The products shown in illustrations in this manual are sometimes shown without covers or protective guards. Always replace the cover or protective guard as specified first, and then operate the products in accordance with the manual.
- The drawings presented in this manual are typical examples and may not match the product you received.
- If the manual must be ordered due to loss or damage, inform your nearest Yaskawa representative or one of the offices listed on the back of this manual.

Warranty

(1) Details of Warranty

■ Warranty Period

The warranty period for a product that was purchased (hereinafter called “delivered product”) is one year from the time of delivery to the location specified by the customer or 18 months from the time of shipment from the Yaskawa factory, whichever is sooner.

■ Warranty Scope

Yaskawa shall replace or repair a defective product free of charge if a defect attributable to Yaskawa occurs during the warranty period above. This warranty does not cover defects caused by the delivered product reaching the end of its service life and replacement of parts that require replacement or that have a limited service life.

This warranty does not cover failures that result from any of the following causes.

1. Improper handling, abuse, or use in unsuitable conditions or in environments not described in product catalogs or manuals, or in any separately agreed-upon specifications
2. Causes not attributable to the delivered product itself
3. Modifications or repairs not performed by Yaskawa
4. Abuse of the delivered product in a manner in which it was not originally intended
5. Causes that were not foreseeable with the scientific and technological understanding at the time of shipment from Yaskawa
6. Events for which Yaskawa is not responsible, such as natural or human-made disasters

(2) Limitations of Liability

1. Yaskawa shall in no event be responsible for any damage or loss of opportunity to the customer that arises due to failure of the delivered product.
2. Yaskawa shall not be responsible for any programs (including parameter settings) or the results of program execution of the programs provided by the user or by a third party for use with programmable Yaskawa products.
3. The information described in product catalogs or manuals is provided for the purpose of the customer purchasing the appropriate product for the intended application. The use thereof does not guarantee that there are no infringements of intellectual property rights or other proprietary rights of Yaskawa or third parties, nor does it construe a license.
4. Yaskawa shall not be responsible for any damage arising from infringements of intellectual property rights or other proprietary rights of third parties as a result of using the information described in catalogs or manuals.

(3) Suitability for Use

1. It is the customer's responsibility to confirm conformity with any standards, codes, or regulations that apply if the Yaskawa product is used in combination with any other products.
2. The customer must confirm that the Yaskawa product is suitable for the systems, machines, and equipment used by the customer.
3. Consult with Yaskawa to determine whether use in the following applications is acceptable. If use in the application is acceptable, use the product with extra allowance in ratings and specifications, and provide safety measures to minimize hazards in the event of failure.
 - Outdoor use, use involving potential chemical contamination or electrical interference, or use in conditions or environments not described in product catalogs or manuals
 - Nuclear energy control systems, combustion systems, railroad systems, aviation systems, vehicle systems, medical equipment, amusement machines, and installations subject to separate industry or government regulations
 - Systems, machines, and equipment that may present a risk to life or property
 - Systems that require a high degree of reliability, such as systems that supply gas, water, or electricity, or systems that operate continuously 24 hours a day
 - Other systems that require a similar high degree of safety
4. Never use the product for an application involving serious risk to life or property without first ensuring that the system is designed to secure the required level of safety with risk warnings and redundancy, and that the Yaskawa product is properly rated and installed.
5. The circuit examples and other application examples described in product catalogs and manuals are for reference. Check the functionality and safety of the actual devices and equipment to be used before using the product.
6. Read and understand all use prohibitions and precautions, and operate the Yaskawa product correctly to prevent accidental harm to third parties.

(4) Specifications Change

The names, specifications, appearance, and accessories of products in product catalogs and manuals may be changed at any time based on improvements and other reasons. The next editions of the revised catalogs or manuals will be published with updated code numbers. Consult with your Yaskawa representative to confirm the actual specifications before purchasing a product.

CONTENTS

Using this Manual	iii
Safety Information	vi
Safety Precautions	vii
Warranty	xii

1 System Overview

1.1 MECHATROLINK System Overview	1-2
1.1.1 MECHATROLINK System	1-2
1.1.2 MECHATROLINK System Features	1-2
1.1.3 MECHATROLINK Transmission Specifications	1-2
1.1.4 Maximum Number of Connectable Slaves	1-3
1.1.5 System Configuration Precautions	1-3
1.2 MECHATROLINK System Configuration	1-5
1.2.1 MECHATROLINK-compatible Devices	1-5
1.2.2 System Configuration Example	1-7

2 I/O Allocations

2.1 MECHATROLINK Master Module Definitions	2-2
2.1.1 Module Configuration Window	2-2
2.1.2 Master Module Settings	2-3
2.1.3 Setting the Leading and End I/O Register Numbers	2-4
2.1.4 Usable Registers	2-5
2.2 Allocating I/O to MECHATROLINK Slave Modules	2-6
2.2.1 MECHATROLINK Definitions Window	2-6
2.2.2 Setting Transmission Parameters	2-7
2.2.3 I/O Map	2-11
2.2.4 Status	2-12
2.2.5 I/O Register Configuration	2-13

3 Distributed I/O Module

3.1 General Specifications	3-3
3.1.1 General Specifications	3-3
3.1.2 Mounting Orientation	3-4
3.2 Relay Contact 8-point Output Module (120DRA83030/IO2950)	3-7
3.2.1 External Appearance and Configuration	3-7
3.2.2 Performance Specifications	3-10
3.2.3 Circuit Configuration	3-11
3.2.4 Connection Example	3-12
3.2.5 I/O Allocations	3-13

3.3	100-VAC 8-point Input Module (120DAI53330)	3-14
3.3.1	External Appearance and Configuration	3-14
3.3.2	Performance Specifications	3-17
3.3.3	Circuit Configuration	3-18
3.3.4	Connection Example	3-18
3.3.5	I/O Allocations	3-19
3.4	200-VAC 8-point Input Module (120DAI73330)	3-20
3.4.1	External Appearance and Configuration	3-20
3.4.2	Performance Specifications	3-23
3.4.3	Circuit Configuration	3-23
3.4.4	Connection Example	3-24
3.4.5	I/O Allocations	3-25
3.5	100/200-VAC 8-point Output Module (120DAO83330)	3-26
3.5.1	External Appearance and Configuration	3-26
3.5.2	Performance Specifications	3-29
3.5.3	Circuit Configuration	3-30
3.5.4	Connection Example	3-31
3.5.5	I/O Allocations	3-32
3.6	24-VDC 8-point I/O Module (IO2920)	3-33
3.6.1	External Appearance and Configuration	3-33
3.6.2	Performance Specifications	3-35
3.6.3	Circuit Configuration	3-37
3.6.4	Connection Example	3-38
3.6.5	I/O Allocations	3-39
3.7	24-VDC 16-point Input Module (120DDI34330/IO2900)	3-40
3.7.1	External Appearance and Configuration	3-40
3.7.2	Performance Specifications	3-43
3.7.3	Circuit Configuration	3-44
3.7.4	Connection Example	3-44
3.7.5	I/O Allocations	3-45
3.8	24-VDC 16-point Output Module (120DDO34340/IO2910)	3-46
3.8.1	External Appearance and Configuration	3-46
3.8.2	Performance Specifications	3-49
3.8.3	Circuit Configuration	3-50
3.8.4	Connection Example	3-51
3.8.5	I/O Allocations	3-52
3.9	Analog Input Module (± 10 V, 4 CH) (120AVI02030/AN2900)	3-53
3.9.1	External Appearance and Configuration	3-53
3.9.2	Performance Specifications	3-56
3.9.3	Input Characteristics	3-57
3.9.4	Circuit Configuration	3-58
3.9.5	Connection Example	3-59
3.9.6	I/O Allocations	3-61

3.10	Analog Output Module (± 10 V, 2 CH) (120AVO01030/AN2910)	3-62
3.10.1	External Appearance and Configuration	3-62
3.10.2	Performance Specifications	3-65
3.10.3	Output Characteristics	3-66
3.10.4	Circuit Configuration	3-67
3.10.5	Connection Example	3-67
3.10.6	I/O Allocations	3-68
4	Other I/O Modules	
4.1	64-point I/O Module (JEPMC-IO350/IO2310/IO2330)	4-2
4.1.1	External Appearance and Configuration	4-2
4.1.2	Performance Specifications	4-6
4.1.3	System Connection	4-9
4.2	Wildcard I/O Modules ($\square\square\square\square$ I/O)	4-19
5	Reversible Counter Module with Preset Function	
5.1	Summary of Module Functions	5-2
5.1.1	High-speed Pulse Counting Function	5-2
5.1.2	Notch Signal Output Function	5-3
5.1.3	Current Value Setting	5-5
5.2	External Appearance and Configuration	5-6
5.3	System Configuration	5-11
5.3.1	Example of System Configuration	5-11
5.3.2	Interface with the Host Controller	5-12
5.4	Specifications	5-13
5.4.1	General Specifications	5-13
5.4.2	Performance Specifications	5-14
5.5	External I/O Signals and Connection Examples	5-24
5.5.1	Overview	5-24
5.5.2	Connection Examples of External I/O Terminals	5-25
5.5.3	I/O Allocations	5-32
5.5.4	Output Coils	5-34
5.5.5	Output Registers	5-35
5.5.6	Input Relays	5-36
5.5.7	Input Registers	5-37
5.5.8	Monitoring Data	5-38
5.6	Precautions on Wiring	5-42
5.6.1	External Pulse Input Circuit (Phase-A Pulse, Phase-B Pulse)	5-42
5.6.2	External Input Circuit (External Latch and External Current Value Reset Functions)	5-44
5.6.3	External Output Circuit (External Notch Output)	5-47

5.7	Module Operation	5-49
5.7.1	Operation Settings	5-49
5.7.2	Ladder Programs	5-54
6	Pulse Output Module	
6.1	Summary of Module Functions	6-2
6.2	External Appearance and Configuration	6-4
6.3	System Configuration	6-8
6.3.1	Example of System Configuration	6-8
6.3.2	Interface with the Host Controller	6-9
6.4	Specifications	6-10
6.4.1	General Specifications	6-10
6.4.2	Performance Specifications	6-11
6.5	External I/O Signals and Connection Examples	6-17
6.6	References	6-20
6.6.1	I/O Allocations	6-20
6.6.2	Output Coils	6-22
6.6.3	Parameters	6-23
6.6.4	Output Registers	6-24
6.6.5	Input Relays	6-25
6.6.6	Input Registers	6-26
6.6.7	Monitoring Data	6-26
6.7	Module Operation	6-31
6.7.1	Operation Flowchart	6-31
6.7.2	Positioning Function	6-32
6.7.3	Jog Operation	6-37
6.7.4	Zero Point Return	6-40
7	PLC Module	
7.1	MP940	7-2
7.1.1	External Appearance and Configuration	7-2
7.1.2	Specifications and Functions	7-5
8	MECHATROLINK-II Repeater	
8.1	Overview	8-2
8.2	External View and Components	8-3
8.3	System Configuration	8-5
8.3.1	System Configuration Example	8-5
8.4	Specifications	8-6
8.5	Application	8-8
8.5.1	Restrictions	8-8
8.5.2	Operation	8-10

9 Connections

9.1 Connections between MECHATROLINK Devices	9-2
9.1.1 MECHATROLINK Connectors	9-2
9.1.2 MECHATROLINK Cables	9-5
9.1.3 Connection Example	9-10
9.2 External Wiring	9-17
9.2.1 Wiring in a Panel	9-17
9.2.2 Indoor Wiring Between Panels	9-18
9.2.3 Outdoor Wiring Between Panels	9-19
9.2.4 Grounding	9-20
9.2.5 Grounding Control Panels	9-21

Appendix A Dimension Diagrams of the Modules

A.1 I/O Modules	A-2
A.1.1 64-point I/O Module	A-2
A.1.2 Relay Contact 8-point Output Module	A-2
A.1.3 100-VAC 8-point Input Module	A-3
A.1.4 200-VAC 8-point Input Module	A-3
A.1.5 100/200-VAC 8-point Output Module	A-4
A.1.6 24-VDC 8-point I/O Module	A-4
A.1.7 24-VDC 16-point Input Module	A-5
A.1.8 24-VDC 16-point Output Module	A-5
A.1.9 Analog Input Module (± 10 V, 4 Channels)	A-6
A.1.10 Analog Output Module (± 10 V, 2 Channels)	A-6
A.2 Reversible Counter Module with Preset Function	A-7
A.3 Pulse Output Module	A-8
A.4 MECHATROLINK-II Repeater	A-9

Appendix B MECHATROLINK Simple I/O Communications Commands

B.1 Simple I/O Communications Commands	B-2
B.1.1 Overview	B-2
B.1.2 Modules that Support Simple I/O Communications Commands	B-2
B.2 Applicable Commands	B-3
B.3 Data Link Layer Commands	B-4
B.3.1 MDS Command	B-4
B.3.2 CDRW Command	B-6

Appendix C MECHATROLINK Intelligent I/O Communications Commands

C.1 Intelligent I/O Communications Commands	C-2
C.1.1 Overview	C-2
C.1.2 Modules that Support Intelligent I/O Communications Commands	C-2
C.2 Applicable Commands	C-3

C.3 Application Layer Commands	C-4
C.3.1 No Operation: NOP (00H)	C-4
C.3.2 Read ID Command (ID_RD: 03H)	C-6
C.3.3 Read Alarm/Warning Command (ALM_RD: 05H).....	C-7
C.3.4 MECHATROLINK Connection Command: CONNECT (0EH).....	C-8
C.3.5 DISCONNECTION Command: DISCONNECT (0FH).....	C-9
C.3.6 Read/Write I/O Data Command: DATA_RWA (50H).....	C-10

Appendix D Supplemental Information

D.1 Using Simple I/O and Intelligent I/O Together	D-2
D.1.1 Master Station State Transition Diagram	D-2
D.1.2 Event Matrices	D-3
D.1.3 ID of Intelligent I/O	D-4

Index

Revision History

System Overview

This section provides an overview of the MECHATROLINK system.

1.1 MECHATROLINK System Overview	1-2
1.1.1 MECHATROLINK System	1-2
1.1.2 MECHATROLINK System Features	1-2
1.1.3 MECHATROLINK Transmission Specifications	1-2
1.1.4 Maximum Number of Connectable Slaves	1-3
1.1.5 System Configuration Precautions	1-3
1.2 MECHATROLINK System Configuration	1-5
1.2.1 MECHATROLINK-compatible Devices	1-5
1.2.2 System Configuration Example	1-7

1.1 MECHATROLINK System Overview

This section provides an overview of the MECHATROLINK system and its features.

1.1.1 MECHATROLINK System

A basic MECHATROLINK system is composed of one MECHATROLINK Master Module and one or more MECHATROLINK slave Modules, which are MECHATROLINK-compatible devices.

The main characteristics of the MECHATROLINK system configuration are listed below:

- A MECHATROLINK system is a motion network that controls several SERVOPACKs and provides distributed control over I/O Modules.
- A MECHATROLINK system's network uses the Master/Slave format.

1.1.2 MECHATROLINK System Features

The MECHATROLINK system features are listed below:

- The MECHATROLINK system now provides high-speed refreshing rates comparable to local I/O. With some Modules in the MP Series, the refreshing rate is selectable, which determines the maximum number of Modules that can be connected.
- MECHATROLINK Modules can be connected with a single twisted-pair cable. This configuration provides remote I/O with less wiring, so a simple and low-cost system can be configured.
- For better fault tolerance, the Master can detect when an error has occurred in a Slave. Also, Slaves other than Servo Modules are equipped with an automatic disconnection/automatic restart function.

There are two protocols of MECHATROLINK transmission as explained below: MECHATROLINK-I (M-I) and MECHATROLINK-II (M-II)

1.1.3 MECHATROLINK Transmission Specifications

The following table shows the MECHATROLINK transmission specifications.

Item	M-I Specifications (MP900 Series)		M-II Specifications (MP2000 Series)	
Transmission Method	M-I	M-I	M-II	
Transmission path form	Bus type	Bus type	Bus type	Bus type
Transmission path	Electric bus	Electric bus	Electric bus	Electric bus
Transmission distance	50 m	50 m	50 m	50 m
Min. distance between stations	0.3 m	0.3 m	0.3 m	0.5 m
Transmission speed	4 Mbps	4 Mbps	4 Mbps	10 Mbps
Communication cycle	2 ms	2 ms	2 ms	0.5 ms/1 ms/1.5 ms/2 ms ^{*1}
Maximum number of connected stations	14 stations	14 stations	14 stations	21 stations ^{*2}
Transmission control method	Cyclic method	Cyclic method	Cyclic method	Cyclic method
Access control method	1 : N	1 : N	1 : N	2 : N ^{*3}
Transmission mode	Control transmission	Control transmission	Control transmission	Control transmission
Error control	CRC check	CRC check	CRC check	CRC check

* 1. The applicable communication cycles differ depending on the specifications of Master Module. Refer to the user's manual of the Master Module for the applicable communication cycles.

* 2. 16 stations when no REP2000 is connected. Refer to *Chapter 8 MECHATROLINK-II Repeater* for REP2000.

* 3. When SigmaWin is used. If not, 1: N.

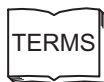

Automatic disconnection:

If an error is detected in communication between the Master and a Slave, the affected Slave will be removed from the network and communication will continue with the unaffected Slaves.

Automatic restart:

The Master will resume communication automatically when it determines that the affected Slave is responding regularly and has resumed normal operation.

1.1.4 Maximum Number of Connectable Slaves

The following table shows the maximum number of slave stations that can be connected to the MP-series Machine Controller.

(1) MECHATROLINK Transmission Settings and Maximum Number of Slave Stations

Master Device (Series Name)	MECHATROLINK Transmission Settings			Maximum Number of Slave Stations
	Method	Transmission Speed	Communication Cycle	
MP900	M-I	4 Mbps	2 ms	14
MP2000	M-I	4 Mbps	2 ms	14
	M-II (17-byte mode)	10 Mbps	0.5 ms	6
			1 ms	15
	M-II (32-byte mode)	10 Mbps	0.5 ms	4
			1 ms	9
			1.5 ms	15
2 ms			21	

Refer to 2.2.2 *Setting Transmission Parameters* for the setting method of MECHATROLINK transmission.

(2) Transmission Distance and Maximum Number of Slave Stations

Master Device (Series Name)	Transmission Method	Transmission Distance (Total Length of Network)	Maximum Number of Slave Stations
MP900	M-I	50 m	14
MP2000	M-I	50 m	14
	M-II	30 m	16 (21)
		50 m	15 (21)

Note: A REP2000 is required to connect more than 17 stations to the MP2000-series Machine Controller for the M-II communications.

IMPORTANT

- When a MP900-series Machine Controller uses only Remote I/O Modules as slave device, up to 29 slave devices can be connected by setting the MECHATROLINK communication cycle to 4 ms. However, with MP930, do not set the communication cycle to any value other than 2 ms.
- Up to 16 servo axes can be connected to the MP2000-series Machine Controller.

1.1.5 System Configuration Precautions

(1) Number of Slave Stations

In the M-II, the number of slaves varies depending on the settings for “SigmaWin” (use/not use) and “Number of retry to slaves.”

SigmaWin Use/Not use: 0 (Use)

- For MECHATROLINK-II (17-byte mode) with the communication cycle set to 1 ms
Number of slave stations = 15 – (Number of retry to slaves + SigmaWin)
- For MECHATROLINK-II (32-byte mode) with the communication cycle set to 1 ms
Number of slave stations = 9 – (Number of retry to slaves + SigmaWin)
- For MECHATROLINK-II (32-byte mode) with the communication cycle set to 2 ms
Number of slave stations = 21 – (Number of retry to slaves + SigmaWin)

The maximum number of servo axes is 16.

(2) MECHATROLINK Transmission Settings

Set the same MECHATROLINK transmission settings both for the master and the slaves.

If M-I and M-II devices are used together, use the M-I settings.

(3) Connection Cables

Use the standard cables.

For details on the standard cables, refer to *9.1.2 MECHATROLINK Cables*.

Refer to *Chapter 9 Connections* to select the cable according to the devices to be used.

(4) Terminator (Terminating Resistor)

Attach a terminator (terminating resistor) on each end of the system.

Some Machine Controllers incorporate terminators as follows.

Machine Controller (MECHATROLINK Master Module)	Terminator Details
MP910	A terminator is required when the Module is at the end of the system.
MP920 (SVB-01)	A terminator is required when the Module is at the end of the system.
MP930	A terminator is not required because one is built into the Module.
MP940	A terminator is required when the Module is at the end of the system.
MP2100	A terminator is not required because one is built into the Module.
MP2300	A terminator is not required because one is built into the Module.
MP2200/MP2300 (SVB-01)	A terminator is required when the Module is at the end of the system.

1.2 MECHATROLINK System Configuration

This section describes MECHATROLINK-compatible devices and precautions.

1.2.1 MECHATROLINK-compatible Devices

The following lists the MECHATROLINK-compatible devices.

(1) Master Devices

Machine Controller	MECHATROLINK Master Module	Model	MECHATROLINK Transmission	
			M-I	M-II
MP910	MC101 Board (ISA)	JEPMC-MC100	Applicable	N/A
	MC151 Board (C-PCI)	JEPMC-MC150	Applicable	N/A
MP920	SVB-01 Module	JEPMC-MC210	Applicable	N/A
MP930	MP930 Module	JEPMC-MC350	Applicable	N/A
		JEPMC-MC360		
MP940	MP940M Module	JEPMC-MC400	Applicable	N/A
MP2100	MC2100 Board	JAPMC-MC2100	Applicable	Applicable
MP2300	Basic Module	JEPMC-MP2300	Applicable	Applicable
MP2310	MP2310 Module	JEPMC-MP2310	Applicable	Applicable
MP2300S	MP2300S Module	JEPMC-MP2300S	Applicable	Applicable
MP2400	MP2400 Module	JEPMC-MP2400	Applicable	Applicable
MP2200/MP2300	SVB-01 Module	JAPMC-MC2310	Applicable	Applicable

(2) Slave Devices

Classification	Device Name	Model	MP910	MP920	MP930	MP940	MP2000 Series	
							M-I	M-II
SERVO-PACK	MECHATROLINK-compatible AC SERVOPACK	SGD-□□□N SGDB-□□AN	Applicable	Applicable	Applicable	N/A	Applicable	N/A
	SGDH SERVOPACK NS100 MECHATROLINK Interface Module	SGDH-□□□E JUSP-NS100	Applicable	Applicable	Applicable	N/A	Applicable	N/A
	SGDH SERVOPACK NS115 M-II Interface Module	SGDH-□□□E JUSP-NS115	N/A	N/A	N/A	N/A	Applicable	Applicable
	SGDS SERVOPACK	SGDS-□□□1□□	N/A	N/A	N/A	N/A	Applicable	Applicable

(cont'd)

Classification	Device Name	Model	MP910	MP920	MP930	MP940	MP2000 Series	
							M-I	M-II
Distributed I/O Module	Relay Contact Module Wide-voltage, 8-point output	JAMSC-120DRA83030	Applicable	Applicable	Applicable	Applicable	Applicable	N/A
		JAMSC-IO2950-E*	Applicable	Applicable	Applicable	Applicable	Applicable	Applicable
	AC Input Module 100 VAC, 8-point input	JAMSC-120DAI53330	Applicable	Applicable	Applicable	Applicable	Applicable	N/A
	AC Input Module 200 VAC, 8-point input	JAMSC-120DAI73330	Applicable	Applicable	Applicable	Applicable	Applicable	N/A
	AC Output Module 100/200 VAC, 8-point output	JAMSC-120DAO83330	Applicable	Applicable	Applicable	Applicable	Applicable	N/A
	DC I/O Module 24 VDC, 8-point input, 8-point output (sinking or sourcing)	JAMSC-IO2920-E	N/A	N/A	N/A	N/A	Applicable	Applicable
	DC Input Module 24 VDC, 16-point input	JAMSC-120DDI34330	Applicable	Applicable	Applicable	Applicable	Applicable	N/A
		JAMSC-IO2900-E*	Applicable	Applicable	Applicable	Applicable	Applicable	Applicable
	DC Output Module 24 VDC, 16-point output	JAMSC-120DDO34340	Applicable	Applicable	Applicable	Applicable	Applicable	N/A
		JAMSC-IO2910-E*	Applicable	Applicable	Applicable	Applicable	Applicable	Applicable
	A/D Module Analog input -10 to 10 V, 4 channels	JAMSC-120AVI02030	Applicable	Applicable	Applicable	Applicable	Applicable	N/A
	A/D Module Analog input -10 to 10 V, 4 channels	JEPMC-AN2900	N/A	N/A	N/A	N/A	Applicable	Applicable
D/A Module Analog output -10 to 10 V, 2 channels	JAMSC-120AVO01030	Applicable	Applicable	Applicable	Applicable	Applicable	N/A	
D/A Module Analog output -10 to 10 V, 2 channels	JEPMC-AN2910	N/A	N/A	N/A	N/A	Applicable	Applicable	
I/O Module	64-point I/O Module 24 VDC, 64-point input, 64-point output (sinking)	JEPMC-IO350	Applicable	Applicable	Applicable	Applicable	Applicable	N/A
		JEPMC-IO2310*	Applicable	Applicable	Applicable	Applicable	Applicable	Applicable
	64-point I/O Module 24 VDC, 64-point input, 64-point output (sourcing)	JEPMC-IC2330*	Applicable	Applicable	Applicable	Applicable	Applicable	Applicable
Counter Module	Counter Module Reversible counter, 2 channels	JAMSC-120EHC21140	Applicable	Applicable	Applicable	N/A	Applicable	N/A
	Counter Module Reversible counter, 2 channels	JEPMC-PL2900	N/A	N/A	N/A	N/A	Applicable	Applicable
Pulse Output Module	Pulse Output Module Pulse output, 2 channels	JAMSC-120MMB20230	Applicable	Applicable	Applicable	N/A	Applicable	N/A
	Pulse Output Module Pulse output, 2 channels	JEPMC-PL2910	N/A	N/A	N/A	N/A	Applicable	Applicable
Others	PLC Module, MP940	JEPMC-MC400	Applicable	Applicable	Applicable	Applicable	Applicable	N/A
	Motion Module, SVB-01	JAPMC-MC2310	N/A	N/A	N/A	N/A	Applicable	Applicable
	Machine Vision System, MYVIS YV250	JEVSA-YV250	N/A	N/A	N/A	N/A	Applicable	Applicable

* Connection to an MP900-series Machine Controller is possible, but the following precautions are required.

The name of the module will not be displayed on the Link Assignment Tab Page of MPE720 version 5. Assign a module with the same number of I/O points instead.

Example: If you use the JEPMC-IO2310 (64 input points and 64 output points), "JEPMC-IO2310" will not be displayed on the tab page, so select the JEPMC-IO350 (also 64 input points and 64 output points).

1.2.2 System Configuration Example

The system configuration example is shown in the following diagram.

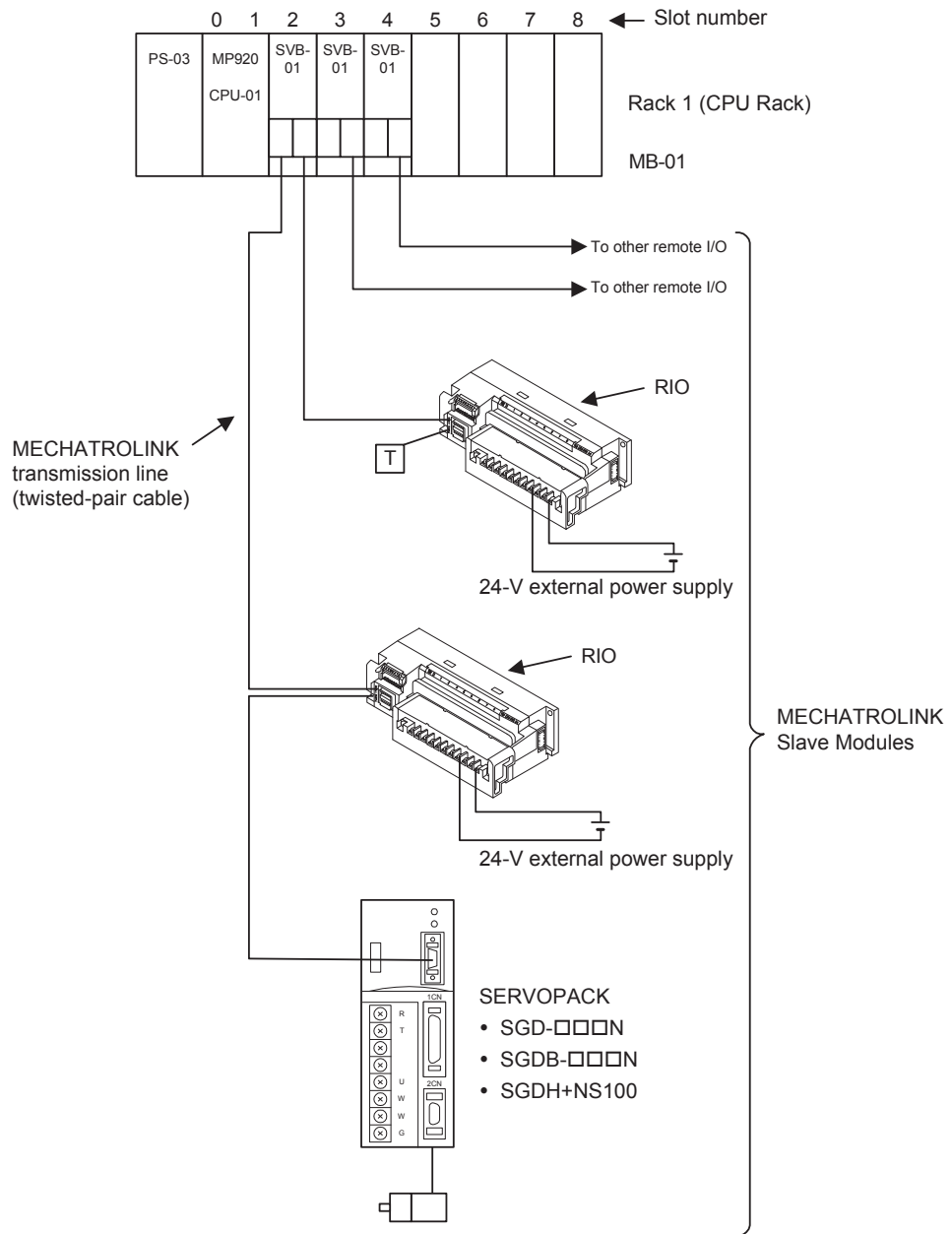

- SVB-01: MECHATROLINK Master Module
- RIO: Distributed I/O Module
- T: Terminator
- MB-01: Mounting Base
- PS-03: AC Input Power Supply Module
- CPU-01: CPU Module

Fig 1.1 MECHATROLINK Network System Configuration Example

I/O Allocations

This section explains how to allocate the I/O registers used to control MECHATROLINK Modules and exchange data.

2.1 MECHATROLINK Master Module Definitions	2-2
2.1.1 Module Configuration Window	2-2
2.1.2 Master Module Settings	2-3
2.1.3 Setting the Leading and End I/O Register Numbers	2-4
2.1.4 Usable Registers	2-5
2.2 Allocating I/O to MECHATROLINK Slave Modules	2-6
2.2.1 MECHATROLINK Definitions Window	2-6
2.2.2 Setting Transmission Parameters	2-7
2.2.3 I/O Map	2-11
2.2.4 Status	2-12
2.2.5 I/O Register Configuration	2-13

2.1 MECHATROLINK Master Module Definitions

This section explains the MECHATROLINK Master Module definitions.

Before allocating I/O registers in the MECHATROLINK Module, the MECHATROLINK Master Module must be set by the module configuration definitions with the MPE720 Software. When the module configuration definitions are changed in online, turn the Master Module power supply OFF and then ON. For details on the Module configuration definitions, refer to the *Machine Controller MP900/MP2000 Series MPE720 Software for Programming Device User's Manual* (SIEPC88070005).

2.1.1 Module Configuration Window

(1) MP900 Series

Open the Module configuration window for the MP900-series Machine Controllers.

Set the "Module," "I/O Start Register," and "I/O End Register." Default values are set for the other items. In the following example, an SVB-01 Module is allocated in slot number 02 of an MP920.

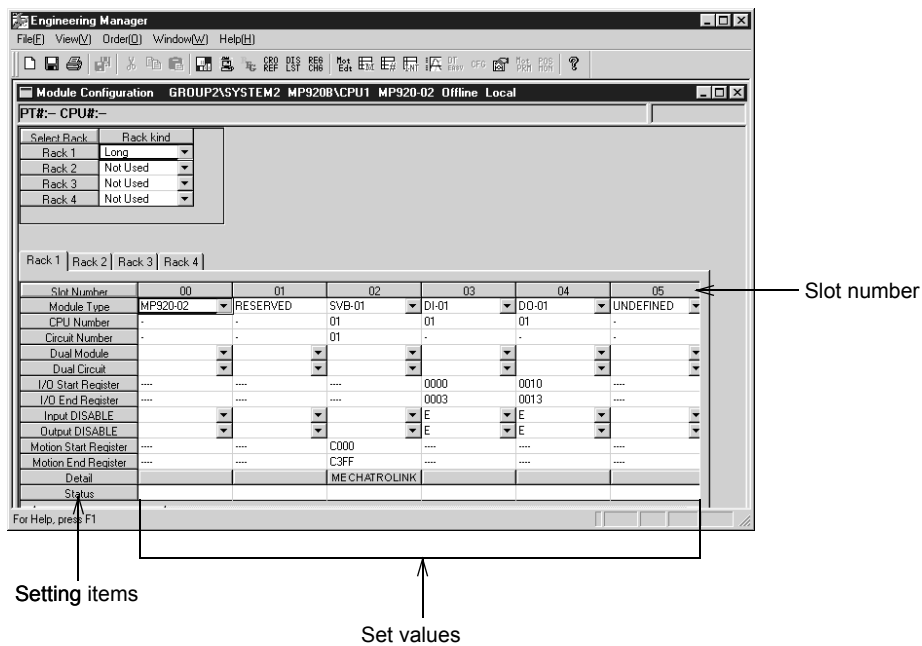

(2) MP2000 Series

Open the Module configuration window for the MP2000-series Machine Controllers. Set the “I/O Start Register” and “I/O End Register” in “SVB” of the sub-slot section. The following example shows the Module configuration definitions of an MP2100.

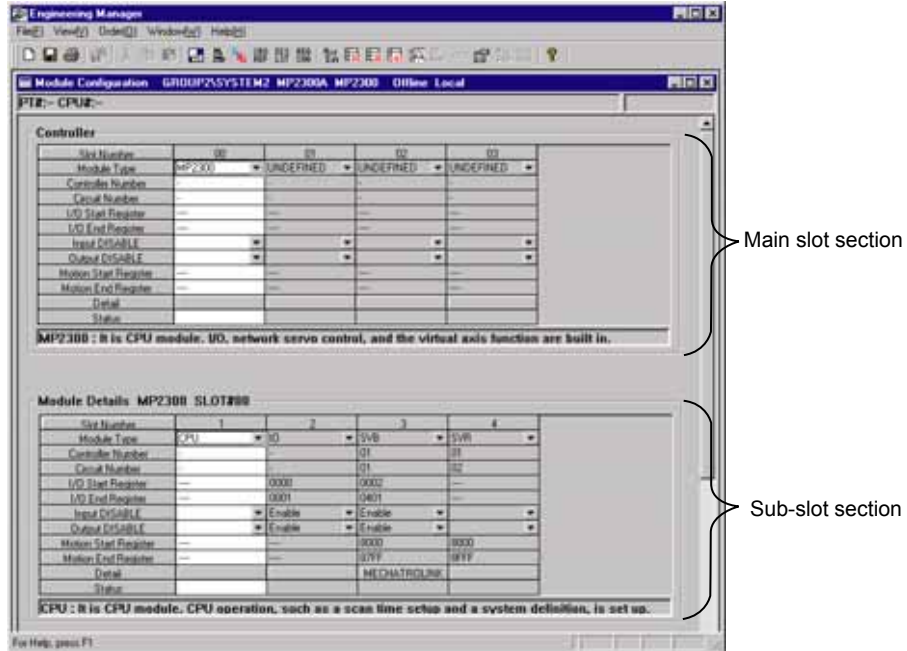

2.1.2 Master Module Settings

Define the Machine Controller Module in the column for slot number 00. Define MECHATROLINK Master Modules in open slots numbered 01 or higher.

Machine Controller	MECHATROLINK Master Module	Remarks
MP910	SVB-01	Select “SVB-01” from the pull-down menu in the Module row for slot number 03.
MP920	SVB-01	Select “SVB-01” from the pull-down menu in the Module row for an open slot.
MP930	MC350-NET	Set automatically.
MP940	MLINK (C)	Select “MLINK(C)” from the pull-down menu in the Module row for slot number 06.
MP2100	SVB	This is set automatically.
MP2300	SVB	This is set automatically.
MP2200/ MP2300	SVB-01	Select “SVB-01” from the pull-down menu in the Module row for an open slot.

2.1.3 Setting the Leading and End I/O Register Numbers

Set the continuous range of I/O register numbers allocated to the MECHATROLINK Slave Module that will be connected. The following lists the sizes of the I/O registers that must be allocated to each MECHATROLINK Slave Modules.

Module	Name	Model	Required Size of I/O Registers (Words)	
			Inputs	Outputs
SERVOPACK	SGD-□□□N	SGD-□□□N	–	–
	SGDB-□□AN	SGDB-□□AN	–	–
	SGDH-□□□E JUSP-NS100	SGDH-□□□E JUSP-NS100	–	–
	SGDH-□□□E JUSP-NS115	SGDH-□□□E JUSP-NS115	–	–
	SGDS-□□□1□□	SGDS-□□□1□□	–	–
Distributed I/O Modules	Relay contact 8-point Output Module	JAMSC-120DRA83030 /JAMSC-IO2950-E	–	1
	100-VAC 8-point Input Module	JAMSC-120DAI53330	1	–
	200-VAC 8-point Input Module	JAMSC-120DAI73330	1	–
	100/200 VAC 8-point Output Module	JAMSC-120DAO83330	–	1
	24-VDC 8-point I/O Module	JAMSC-IO2920-E	1	1
	24-VDC 16-point Input Module	JAMSC-120DDI34330 /JAMSC-IO2900-E	1	–
	24-VDC 16-point Output Module	JAMSC-120DDO34340 /JAMSC-IO2910-E	–	1
	Analog Input Module (±10 V, 4CH)	JAMSC-120AVI02030 /JEPMC-AN2900	7	2
	Analog Output Module (±10 V, 2CH)	JAMSC-120AVO01030 /JEPMC-AN2910	2	4
I/O Modules	64-point I/O Module	JEPMC-IO350	4	4
		JEPMC-IO2310	4	4
		JEPMC-IO2330	4	4
	Wildcard I/O Module	□□□□□I/O	Any	Any
Counter Modules	Reversible Counter with Preset Function	JAMSC-120EHC21140	7	8
		JEPMC-PL2900	7	8
Pulse Output Modules	Pulse MC Module	JAMSC-120MMB20230	8	8
		JEPMC-PL2910	8	8
Others	MP940	JEPMC-MC400	8	8
	SVB-01	JAPMC-MC2310	8	8
	YV250	JEVSA-YV250	8	8

2.1.4 Usable Registers

The following shows the I/O register numbers that can be allocated to refer to the I/O data.

The I/O register numbers differ depending on the Machine Controller model.

Allocation Register	Machine Controller						
	MP910	MP920	MP930	MP940	MP2100	MP2300	MP2200
Input Register Number	IW0000 to IW13FF	IW0000 to IW13FF	IW0000 to IW07FF	IW0000 to IW07FF	IW0000 to IW13FF	IW0000 to IW13FF	IW0000 to IW7FFF
Output Register Number	OW0000 to OW13FF	OW0000 to OW13FF	OW0000 to OW07FF	OW0000 to OW07FF	OW0000 to OW13FF	OW0000 to OW13FF	OW0000 to OW7FFF

Note: I/O register numbers allocated to different modules must not overlap.

And, input register numbers and output register numbers must not overlap.

2.2 Allocating I/O to MECHATROLINK Slave Modules

After completing the MECHATROLINK Master Module's settings, allocate I/O registers of each MECHATROLINK Slave Module that will be connected to the MECHATROLINK network in the MPE720's MECHATROLINK definitions window.

When the I/O allocation is changed in online, turn OFF and then ON the Master Module power supply.

2.2.1 MECHATROLINK Definitions Window

(1) Opening the MECHATROLINK Definitions Window

Open the MECHATROLINK definitions window first. The procedure depends upon the MECHATROLINK Master Module being used.

(a) MP910, MP920

Double-click the "MECHATROLINK" in the "Details" row for the slot in which the SVB-01 Module is defined in the Module configuration window.

(b) MP930, MP940

Double-click the slot number in the top row of the column in which the MECHATROLINK is defined in the Module configuration window.

(c) MP2000-series

Double-click the "MECHATROLINK" in the "Details" row for the slot in which the SVB Module is defined in the sub-slot section of the Module configuration window.

(2) Configuration Information

The MECHATROLINK definitions window's configuration information is displayed below the window title. This information mirrors the information set in the Module configuration window.

Configuration Information	Contents
PT#	Displays the logical port number being used when online.
CPU#	Displays the CPU number logged in when online.
Rack number	Displays the rack number where the Master Module is defined.
Slot number	Displays the slot number where the Master Module is defined.
Circuit number	Displays the circuit number of the MECHATROLINK.
Register range	Displays the range of I/O registers.

(3) Tab Pages

Four tab pages are used when allocating resources to each MECHATROLINK Module.

Tab Page	Function
Transmission Parameters	Sets the basic MECHATROLINK transmission parameters.
I/O Assignment	Allocates I/O registers to MECHATROLINK Modules.
I/O Map	Displays a detailed I/O map.
Status	Displays the transmission status when online.

2.2.2 Setting Transmission Parameters

(1) “Transmission Parameters” Tab Page

Click the MECHATROLINK definitions window’s Transmission Parameters Tab Page. The Transmission Parameters Tab Page will be displayed when the MECHATROLINK definitions window is opened.

(a) MP900 Series

Parameter	Function	Default Setting
Master/Slave	Set whether the Machine Controller is used as a master or slave.	Master
Own Station Address	When the Machine Controller is the master, the station address is fixed at 0. When it is a slave, set the station address between 1 and 14.	0
Message Trust Level	Set the error recovery method used when sending MEMOBUS commands. Set the required message reliability level. (See table below.)	0
Max. Slave ST Number	Open the pull-down menu to display the various combinations of the number of slaves, communication speed, and communication period settings. Select the desired combination.	14
Scan	Specify High or Low.	Low

Level	Function
0	Sends the command once and waits indefinitely for a response from the destination.
1	Sends the command once and resends the command if a response is not received within 8 seconds.
2	Transmits each word of the command twice in succession and waits indefinitely for a response from the destination. This method provides high quality transmissions, but cuts the transmission efficiency in half.

(b) MP2000 Series

Transmission Parameters		Link Assignment	I/O Map	Status
Communication Type	MECHATROLINK-II (32 Byte Mode)			
Master/Slave	Master			
My station address	0			
Transmission Speed	10Mbps			
Transmission Byte	31Byte			
Communication Cycle	1msec			
SigmaWin	not use			
Number of retry to slaves	1			
Number of slaves	8			

Parameter	Function	Default
Communication Type	Sets the MECHATROLINK communication method.	MECHATROLINK-II (32 Byte Mode)
Master/Slave	Sets whether the Machine Controller is used as a master or slave.	Master
My Station Address (Local Station Address)	When the Machine Controller is the master, the station address is fixed at 0. When it is a slave, set the station address between 1 and 14.	0
Transmission Speed	Displays the transmission speed. Transmission speed is displayed when the communication method is set to M-II.	10 Mbps
Transmission Byte	Displays the number of transmission bytes. The number of transmission bytes is displayed when the communication method is set to M-II.	31 Byte
Communication Cycle	Sets the communication cycle.	1 msec
Message Confidence Level *	Set the error recovery method used when sending MEMOBUS commands. Set the required message reliability level.	0
SigmaWin	Sets whether SigmaWin is to be used or not. Can be set only when M-II is selected for the communication method.	Not use
Number of retry to slaves	Sets the number of retry stations. Can be set only when M-II is selected.	1
Number of slaves	Displays the maximum number of slave stations. The maximum number of slave stations depends on the communication method or communication cycle.	8

* Displayed only for M-I.

(2) I/O Allocation

Click the MECHATROLINK definitions window's I/O Assignment Tab Page.

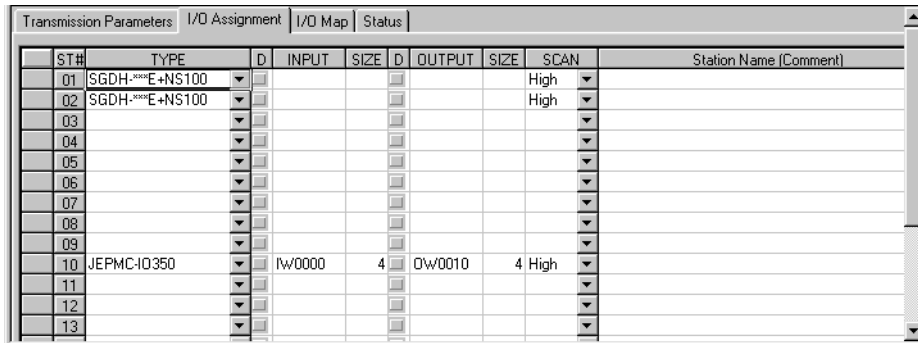

Parameter	Function
ST#	Displays the station number. Up to 14 stations can be set.
TYPE	Sets the model of MECHATROLINK Module connected at the station. Select the module from the drop-down list.
D (Input Register Enable/Disable)	A check mark disables the input registers. <input type="checkbox"/> Enabled <input checked="" type="checkbox"/> Disabled
INPUT, SIZE	Sets the leading input register number and the number of registers (size). The number of registers is set automatically. The register ranges specified for different stations must not overlap. The register numbers can be set within the range specified by the leading and end I/O register numbers set in the Module configuration definitions.
D (Output Register Enable/Disable)	A check mark disables the output registers.
OUTPUT, SIZE	Sets the leading output register number and the number of registers (size). The number of registers is set automatically. The register ranges specified for different stations must not overlap. The register numbers can be set within the range specified by the leading and end I/O register numbers set in the Module configuration definitions.
SCAN	Sets the scan used for I/O servicing. Corresponds to the scan setting in the Transmission Parameters Tab Page.
Station name (Comment)	A comment up to 32-characters long can be input for each station.

The following settings can be made for the TYPE, SIZE, and SCAN parameters. The settings marked with a “-” are set automatically by the system and cannot be set by the user.

TYPE	SIZE		SCAN
	INPUT	OUTPUT	
SGD-□□□N	-	-	High
SGDB-□□□N	-	-	High
SGDH-□□□E+NS100	-	-	High
SGDH-□□□E+NS115	-	-	High
SGDS-□□□1□□	-	-	High
120DRA83030	-	1	High/Low
120DAI53330	1	-	High/Low
120DAI73330	1	-	High/Low
120DAO83330	-	1	High/Low
120DDI34330	1	-	High/Low
120DDO34340	-	1	High/Low
120AVI02030	7	2	High/Low
JEPMC-AN2900	7	2	High/Low
120AVO01030	2	4	High/Low
JEPMC-AN2910	2	4	High/Low
JEPMC-IO350	4	4	High/Low
JEPMC-IO2310	4	4	High/Low
JEPMC-IO2330	4	4	High/Low
□□□□I/O	Any	Any	High/Low
120EHC21140	7	8	High/Low
JEPMC-PL2900	7	8	High/Low
120MMB20230	8	8	High/Low
JEPMC-PL2910	8	8	High/Low
MP940	8	8	High/Low
SVB-01	8	8	High/Low
YV250	8	8	High/Low



Observe the following precautions when setting the I/O register number ranges:

- Input register numbers and output register numbers must not overlap.
- I/O register numbers allocated to different stations must not overlap.

2.2.3 I/O Map

Click the MECHATROLINK definitions window's I/O Map Tab Page.

The I/O Map Tab shows the scan setting (High or Low) of the I/O registers allocated to each station and allows the user to change these settings. The settings are abbreviated HI, HO, LI, and LO

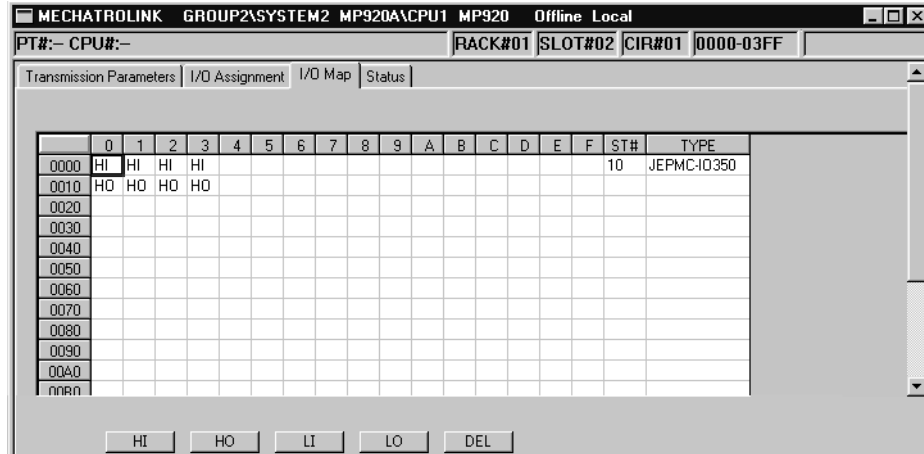

Button	Function
HI	Allocates a high-speed scan input.
HO	Allocates a high-speed scan output.
LI	Allocates a low-speed scan input.
LO	Allocates a low-speed scan output.
DEL	Deletes the allocation.



- With the MP940, scan allocations are not allowed from the I/O Map. All allocations correspond to the scan settings in the Transmission Parameters Tab Page.
- With the MP930, the I/O Map cannot be changed.
- The scan setting can be changed in the I/O Map (e.g., LI to HI), but the I/O setting (e.g., LO to LI) cannot be changed.

2.2.4 Status

Click the MECHATROLINK definitions window's Status Tab Page. The data currently being transmitted by MECHATROLINK will be displayed

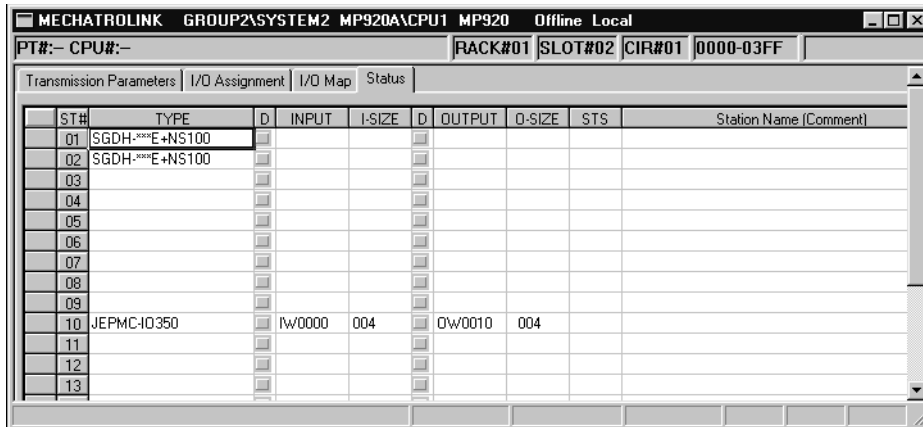

This tab page just displays the status; the set values cannot be changed in this window. The functions of the parameters in the Status Tab are identical to those of the I/O Assignment Tab. The only difference is the addition of the "STS" column.

- STS

In online mode, the MECHATROLINK transmission status is displayed in hexadecimal. The following diagram shows the meaning of each bit. Nothing will be displayed in the STS column when offline.

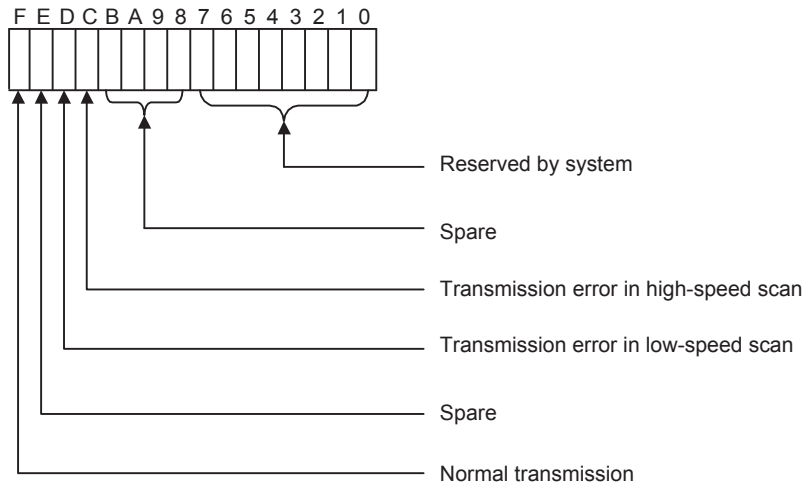

2.2.5 I/O Register Configuration

A continuous range of I/O registers was allocated to each MECHATROLINK Module.

(1) 120DRA83030/IO2950 (Relay contact 8-point Output Module)

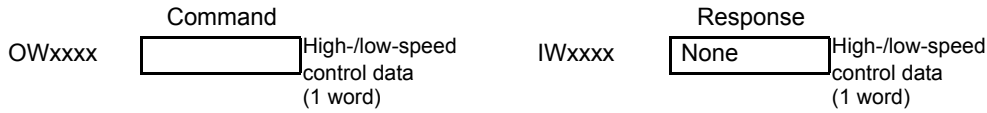

(2) 120DAI53330 (8-point Input Module)

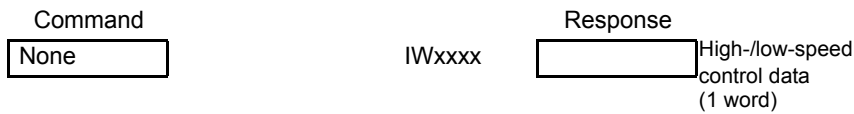

(3) 120DAI73330 (8-point Input Module)

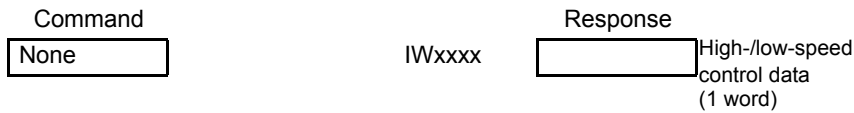

(4) 120DAO83330 (8-point Output Module)

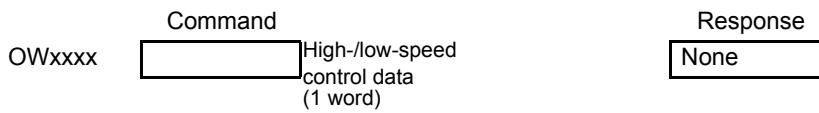

(5) IO2920 (8-point I/O Module)

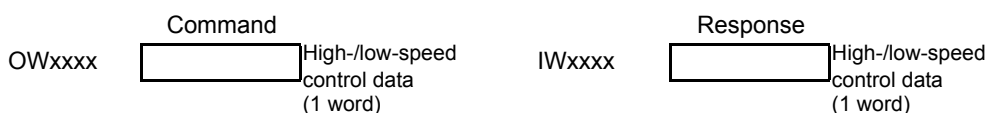

IMPORTANT

I/O registers are allocated in 1-word units, but there are Modules that require only 1 byte. Output Modules use the higher-place byte and Input Modules use the lower-place byte, as shown below.

- Output Modules

The higher-place byte is used and the contents of the lower-place byte are undefined.

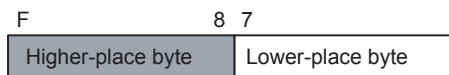

Bits OBxxxx8 to OBxxxxF are valid.

- Input Modules

The lower-place byte is used and the contents of the higher-place byte are undefined.

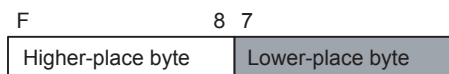

Bits IBxxxx0 to IBxxxx7 are valid.

(6) 120DDI34330/IO2900 (16-point Input Module)

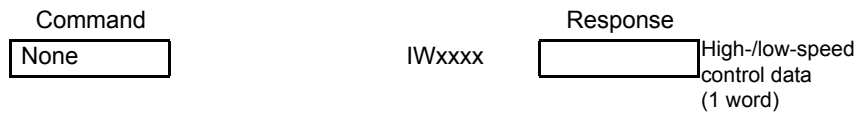

(7) 120DDO34340/IO2910 (16-point Output Module)

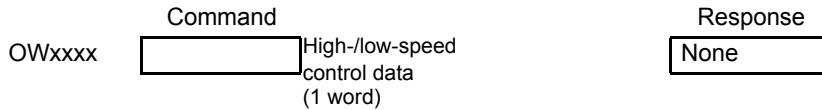

(8) □□□□□I/O (Wildcard I/O Module)

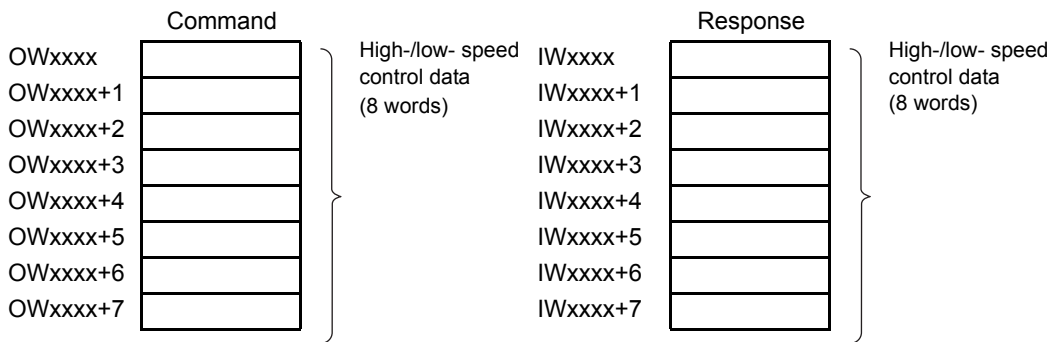

(9) 120AVI02030/AN2900 (Analog Input Module)

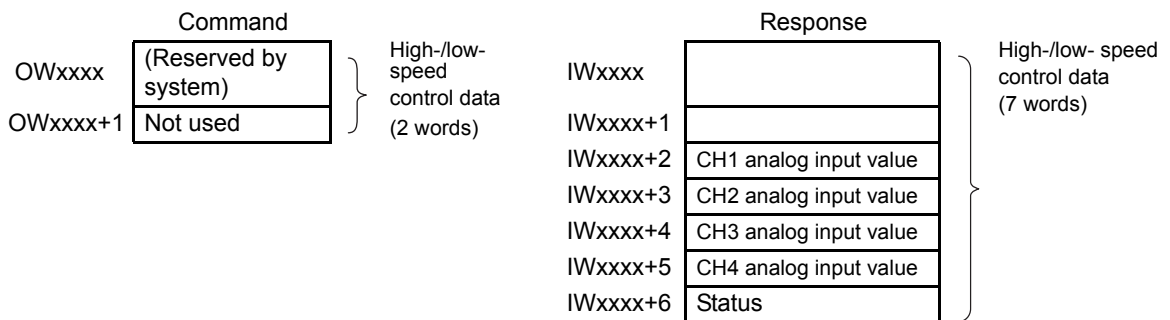

(10) 120AVO01030/AN2910 (Analog Output Module)

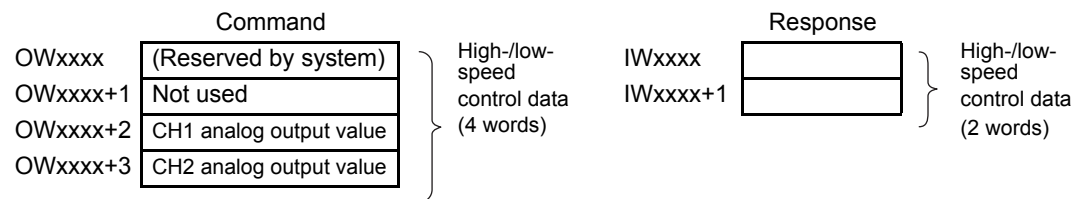

(11) IO350/IO2310/IO2330 (64-point I/O Module)

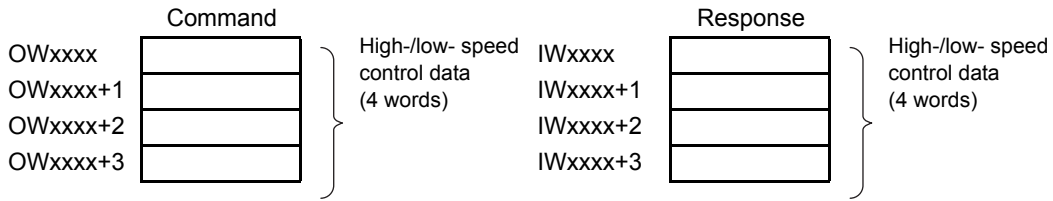

(12) 120EHC21140/PL2900 (Counter Module with Preset)

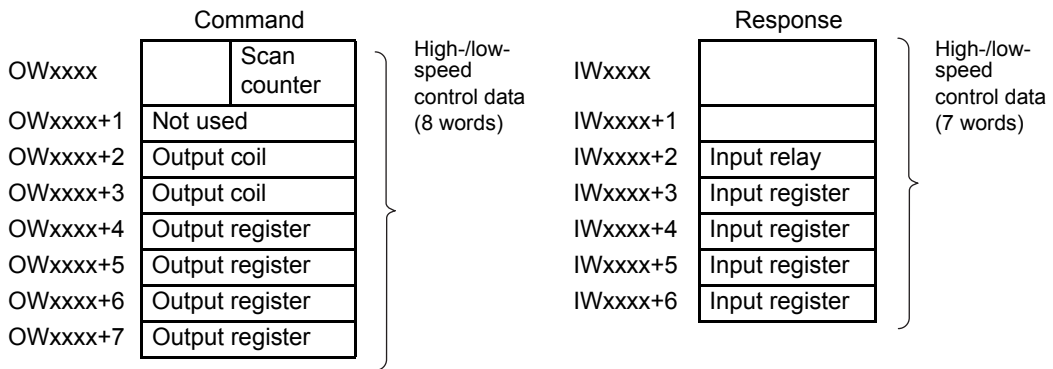

(13) 120MMB20230/PL2910 (Pulse MC Module)

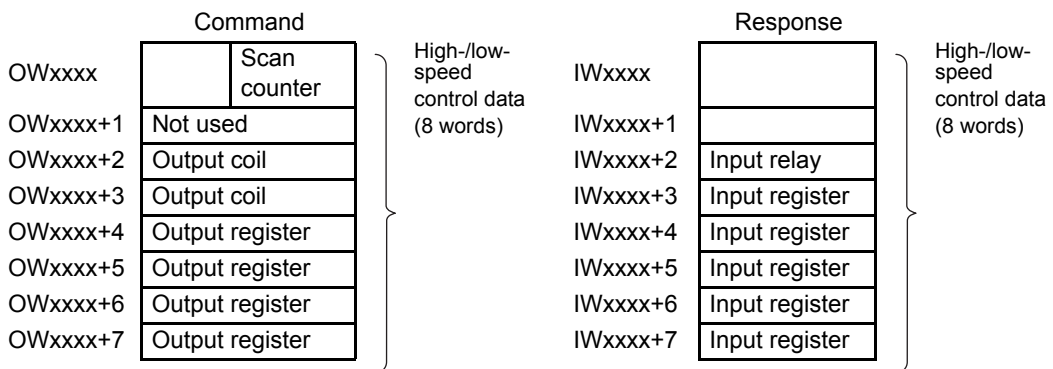

IMPORTANT

The Counter Module with Preset and Pulse Output Module have the first 2 words reserved by the system, so the settings are required to output. For details, refer to *Chapter 5 Reversible Counter Module with Preset Function* and *Chapter 6 Pulse Output Module*.

(14) MP940 (Machine Controller)

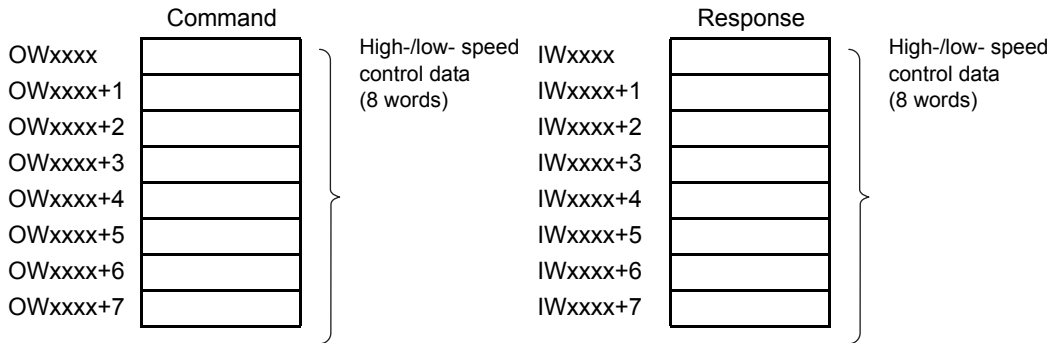

(15) MP2200/MPP2300 SVB-01 (Motion Module)

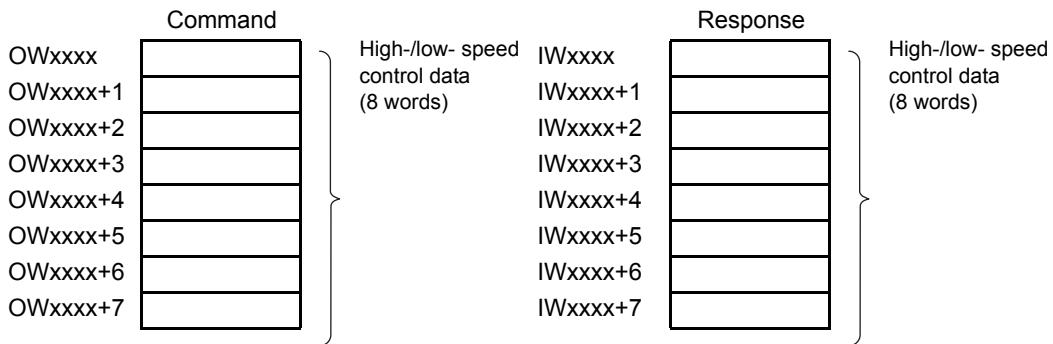

(16) MYVIS YV250 (Machine Vision System)

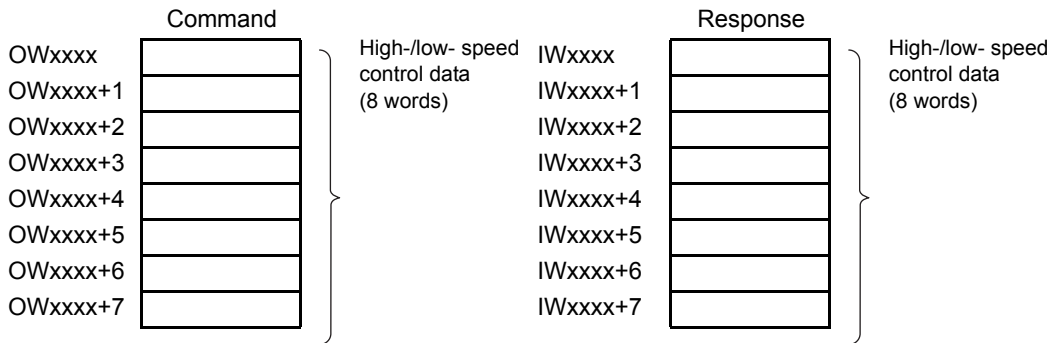

Distributed I/O Module

This section provides an overview of the Distributed I/O Modules.

3.1 General Specifications	3-3
3.1.1 General Specifications	3-3
3.1.2 Mounting Orientation	3-4
3.2 Relay Contact 8-point Output Module (120DRA83030/IO2950)	3-7
3.2.1 External Appearance and Configuration	3-7
3.2.2 Performance Specifications	3-10
3.2.3 Circuit Configuration	3-11
3.2.4 Connection Example	3-12
3.2.5 I/O Allocations	3-13
3.3 100-VAC 8-point Input Module (120DAI53330)	3-14
3.3.1 External Appearance and Configuration	3-14
3.3.2 Performance Specifications	3-17
3.3.3 Circuit Configuration	3-18
3.3.4 Connection Example	3-18
3.3.5 I/O Allocations	3-19
3.4 200-VAC 8-point Input Module (120DAI73330)	3-20
3.4.1 External Appearance and Configuration	3-20
3.4.2 Performance Specifications	3-23
3.4.3 Circuit Configuration	3-23
3.4.4 Connection Example	3-24
3.4.5 I/O Allocations	3-25
3.5 100/200-VAC 8-point Output Module (120DAO83330)	3-26
3.5.1 External Appearance and Configuration	3-26
3.5.2 Performance Specifications	3-29
3.5.3 Circuit Configuration	3-30
3.5.4 Connection Example	3-31
3.5.5 I/O Allocations	3-32
3.6 24-VDC 8-point I/O Module (IO2920)	3-33
3.6.1 External Appearance and Configuration	3-33
3.6.2 Performance Specifications	3-35
3.6.3 Circuit Configuration	3-37
3.6.4 Connection Example	3-38
3.6.5 I/O Allocations	3-39

3.7 24-VDC 16-point Input Module (120DDI34330/IO2900) - - - - -	3-40
3.7.1 External Appearance and Configuration - - - - -	-3-40
3.7.2 Performance Specifications - - - - -	-3-43
3.7.3 Circuit Configuration - - - - -	-3-44
3.7.4 Connection Example - - - - -	-3-44
3.7.5 I/O Allocations - - - - -	-3-45
3.8 24-VDC 16-point Output Module (120DDO34340/IO2910) - - - - -	3-46
3.8.1 External Appearance and Configuration - - - - -	-3-46
3.8.2 Performance Specifications - - - - -	-3-49
3.8.3 Circuit Configuration - - - - -	-3-50
3.8.4 Connection Example - - - - -	-3-51
3.8.5 I/O Allocations - - - - -	-3-52
3.9 Analog Input Module (± 10 V, 4 CH) (120AVI02030/AN2900) - - - - -	3-53
3.9.1 External Appearance and Configuration - - - - -	-3-53
3.9.2 Performance Specifications - - - - -	-3-56
3.9.3 Input Characteristics - - - - -	-3-57
3.9.4 Circuit Configuration - - - - -	-3-58
3.9.5 Connection Example - - - - -	-3-59
3.9.6 I/O Allocations - - - - -	-3-61
3.10 Analog Output Module (± 10 V, 2 CH) (120AVO01030/AN2910) - - - - -	3-62
3.10.1 External Appearance and Configuration - - - - -	-3-62
3.10.2 Performance Specifications - - - - -	-3-65
3.10.3 Output Characteristics - - - - -	-3-66
3.10.4 Circuit Configuration - - - - -	-3-67
3.10.5 Connection Example - - - - -	-3-67
3.10.6 I/O Allocations - - - - -	-3-68

3.1 General Specifications

This section describes the general specifications and installation methods for Distributed I/O Modules.

3.1.1 General Specifications

The specifications of Distributed I/O Modules are shown below.

Item		Specifications
Main External Power Supply	Rated Voltage	24 VDC (insulating DC/DC converter)
	Allowable Voltage Range	20.4 to 26.4 VDC
	Allowable Ripple	Not to exceed +10% or -15%
	Current Consumption	Listed in each Distributed I/O Module's performance specifications.
Dielectric Strength		500 VAC for 1 minute between the I/O terminals and power supply terminals Insulated with a DC/DC converter.
Insulation Resistance		50 MΩ min. (at room temperature and humidity) for 500 VDC insulation resistance between the I/O terminals and power supply terminals Insulated with a DC/DC converter.
Environmental Conditions	Ambient Operating Temperature	0 to 60°C The max. temperature depends on the Module's mounting direction. Refer to <i>3.1.2 Mounting Orientation</i> for details.
	Storage Temperature	-25 to 85°C
	Operating Humidity	30% to 95% (with no condensation)
	Storage Humidity	5% to 95% (with no condensation)
	Pollution Level	Pollution level 1 according to JIS B 3501
	Corrosive Gas	No corrosive gas
	Operating Altitude	Less than 2,000 m above sea level
Mechanical Operating Conditions	Vibration Resistance	10 to 57 Hz with half-amplitude of 0.075 mm 57 to 150 Hz at fixed acceleration of 9.8 m/s ² 10 sweeps for 8 minutes each in X, Y, and Z directions (sweep period: 1 octave/min) (conforming to JIS B 3502)
	Shock Resistance	Peak acceleration of 147 m/s ² twice for 11 ms in X, Y, and Z directions (conforming to JIS B 3502)
Electrical Operating Conditions	Noise Resistance	Impulse noise: ±1,000 V Fast transient burst noise: Level 3 (1,000 V)
Installation Requirements	Ground	Ground (to less than 0.1Ω) the FG terminal of the AC input to the main external power supply (24 VDC).
	Configuration	Individual unit mounting The Modules can be mounted in three directions, although the max. operating temperature will be lower with some mounting directions. Refer to <i>3.1.2 Mounting Orientation</i> for details.
	Cooling Method	Natural cooling
	Mass	Listed in each Distributed I/O Module's performance specifications.
	Dimensions	Listed in each Distributed I/O Module's performance specifications.

3.1.2 Mounting Orientation

⚠ CAUTION

- Always install the Module in the specified orientation.
There is a risk of Module falling, damage, or malfunction.
- The ambient operating temperature will be limited with some mounting orientations.
Failure to observe this caution may result in failures and malfunctions of the Module.

⊘ PROHIBITED

- The mounting orientations shown in the following diagrams are prohibited. Be sure to mount the Module in the correct orientation.
The Module may fall, fail, or malfunction if it is not installed in the proper orientation.

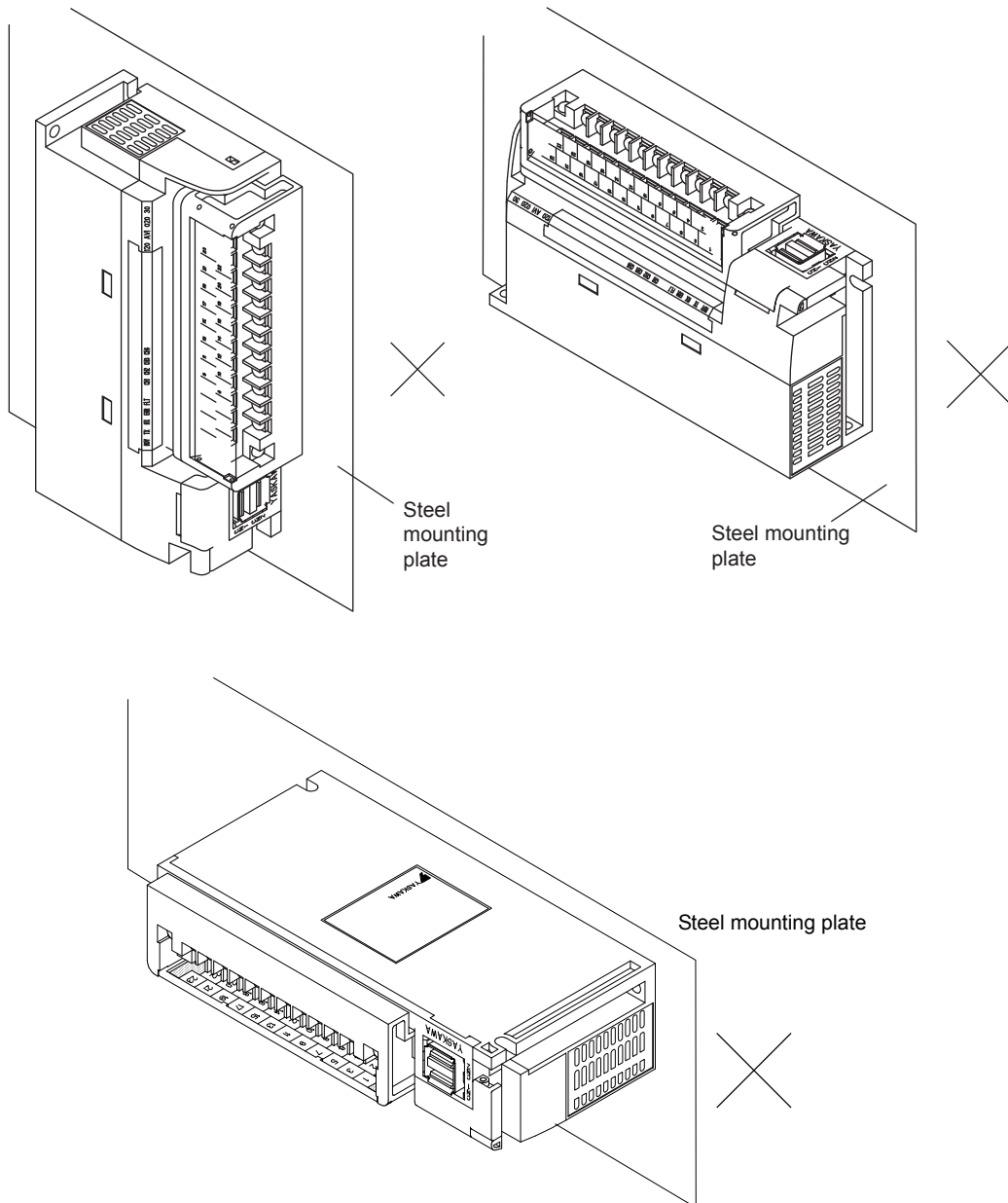

The Distributed I/O Module can be mounted in three directions. The max. ambient operating temperature will be lower with some mounting directions.

The following diagrams show the allowed mounting orientations and the corresponding ambient operating temperature ranges.

(1) Mounting Orientation 1

The ambient operating temperature range is 0 to 60°C when the Module is mounted in the following orientation

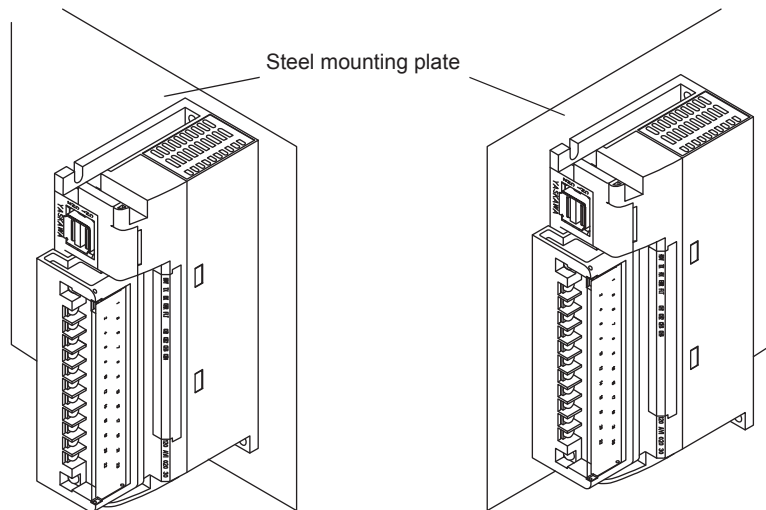

(2) Mounting Orientation 2

The ambient operating temperature range is 0 to 55°C when the Module is mounted in the following orientation.

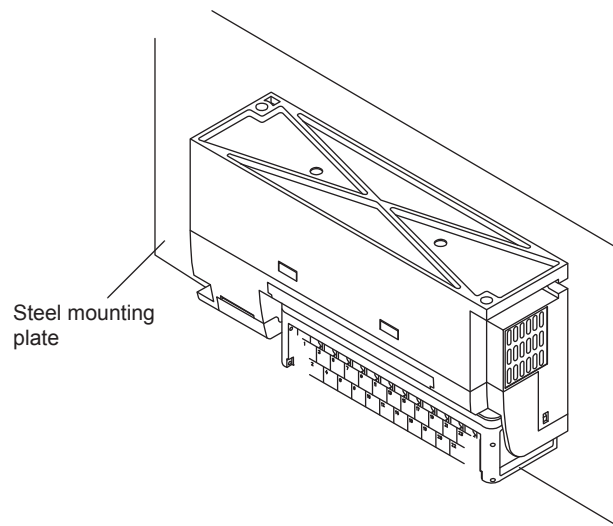

(3) Mounting Orientation 3

The ambient operating temperature range is 0 °C to 55 °C when the Module is mounted in the following orientation.

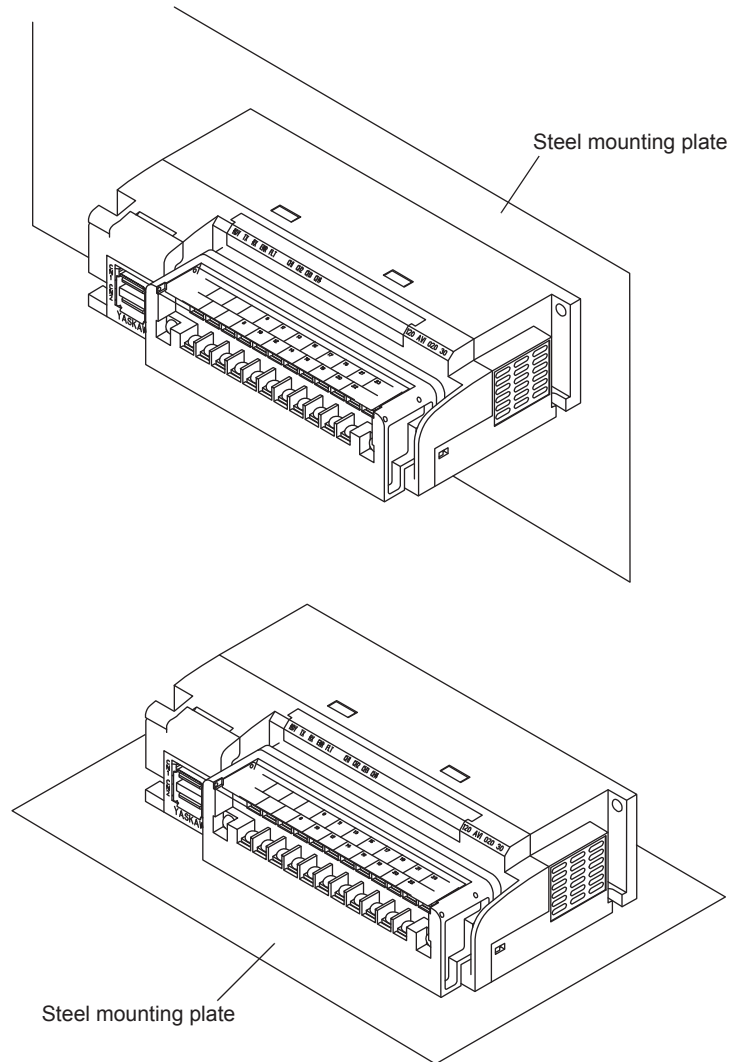

3.2 Relay Contact 8-point Output Module (120DRA83030/IO2950)

3.2.1 External Appearance and Configuration

The following diagram shows the Relay Contact 8-point Output Module's external parts.

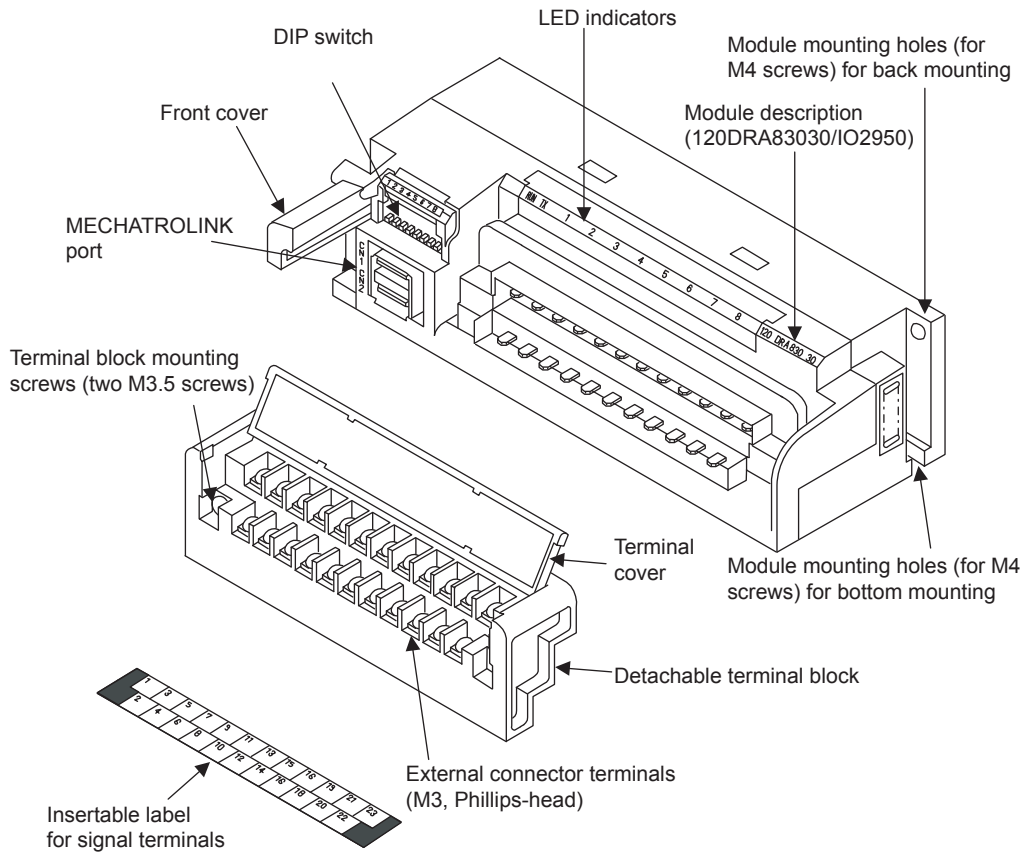

(1) LED Indicators

RUN	TX	1	2	3	4	5	6	7	8
Indicator Name	Indicator Color	Meaning When Lit							
RUN	Green	The external power is being supplied normally.							
TX	Green	Sending data.							
1 to 8	Green	The corresponding indicator is lit when that input signal is ON.							

(2) DIP Switch

Before using the Relay Contact 8-point Output Module, the settings for the DIP switch on the front of the Module must be made.

(a) DIP Switch Functions

The DIP switch consists of eight pins. The pins are numbered 1 to 8, as shown in the following diagram. Each pin is turned to ON when it is moved to the upper position.

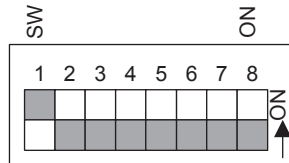

The setting of each pin becomes effective as soon as the DIP switch is changed.

The following table shows the functions that correspond to the settings for each pin.

- 120DRA83030

Pin No.	Setting	Function	Factory Setting
1 to 5	ON	Set the slave address of pins 1 through 5. For details, refer to (b) <i>Slave Address Settings</i> .	1: ON 2 to 5: OFF
	OFF		
6	ON	Set the baud rate to 1 Mbps.	OFF
	OFF	Set the baud rate to 4 Mbps.	
7	ON	With a Digital Output Module, the user can select the status of output data when communication is stopped. This setting retains the status of the outputs that existed before communication stopped.	OFF
	OFF	With a Digital Output Module, the user can select the status of output data when communication is stopped. This setting turns OFF all outputs when communication stops.	OFF
8	ON	Reserved for future use. Leave pin 8 in the OFF position.	OFF
	OFF		

- IO2950

Pin No.	Setting	Function	Factory Setting
1 to 5	ON	Set the slave address of pins 1 through 5. For details, refer to (b) <i>Slave Address Settings</i> .	1: ON 2 to 5: OFF
	OFF		
6	ON	Set the communication type to 32 Bytes.	OFF
	OFF	Set the communication type to 17 Bytes.	
7	ON	The user can select the status of output data when communication is stopped. This setting retains the status of the outputs that existed before communication stopped.	OFF
	OFF	The user can select the status of output data when communication is stopped. This setting turns OFF all outputs when communication stops.	
8	ON	Set the baud rate to 10 Mbps.	OFF
	OFF	Set the baud rate to 4 Mbps.	

(b) Slave Address Settings

Set the slave address with pins 1 to 5 on the DIP switch on the front of the Distributed I/O Module. Refer to the following table, and set the slave addresses as required.

Pin No.					Slave Address
1	2	3	4	5	
0	0	0	0	0	Not used
1	0	0	0	0	1
0	1	0	0	0	2
1	1	0	0	0	3
0	0	1	0	0	4
1	0	1	0	0	5
0	1	1	0	0	6
1	1	1	0	0	7
0	0	0	1	0	8
1	0	0	1	0	9
0	1	0	1	0	10
1	1	0	1	0	11
0	0	1	1	0	12
1	0	1	1	0	13
0	1	1	1	0	14
1	1	1	1	0	15
0	0	0	0	1	16
1	0	0	0	1	17
0	1	0	0	1	18
1	1	0	0	1	19
0	0	1	0	1	20
1	0	1	0	1	21
0	1	1	0	1	22
1	1	1	0	1	23
0	0	0	1	1	24
1	0	0	1	1	25
0	1	0	1	1	26
1	1	0	1	1	27
0	0	1	1	1	28
1	0	1	1	1	29
0	1	1	1	1	30
1	1	1	1	1	Not used

IMPORTANT

- The maximum number of slave stations depends on the method used for MECHATROLINK communication. Confirm the number of slave stations, and set the number of stations to a value that is equal to or less than the number of stations available.
- Do not duplicate a slave address within one communication circuit. Distributed I/O modules with duplicate slave addresses will not communicate correctly with each other or other devices.
- A new slave address set with pins 1 to 5 becomes effective as soon as the DIP switch is changed.

3.2.2 Performance Specifications

The performance specifications of Relay Contact 8-point Output Module are shown below.

Item		Specifications		
		120DRA83030	IO2950	
Name		Relay Contact 8-point Output Module		
Model Description		V_RELAY-8P	IO2950	
Model Number		JAMSC-120DRA83030	JAMSC-IO2950-E	
Contact Specifications	Rated Voltage/Current	200 VAC, 1 A, resistive load 24 VDC, 1 A, resistive load		
	Maximum Switching Power	AC load: 750 VA DC load: 90 W		
	Maximum Switching Voltage	264 VAC, 125 VDC		
	Minimum Switching Voltage/Current	100 mVDC, 0.1 mA	Approx. 10 mA	
	Contact Resistance	100 mΩ max.		
	Electrical Contact Life	30 VDC, 5 A, Resistive load: 100,000 operations min.		30 VDC, 5 A, Resistive load: 70,000 operations min. 30 VDC, 2 A, Resistive load: 300,000 operations min.
		250 VAC, 3 A, Resistive load: 150,000 operations min.		250 VAC, 5 A, Resistive load: 70,000 operations min. 250 VAC, 2 A, Resistive load: 300,000 operations min.
Mechanical Contact Life		20,000,000 operations min.		
Output Delay Times		OFF to ON: 10 ms max. ON to OFF: 15 ms max.		
Output Type		Relay contact outputs		
External Connections		Removable terminal block with M3 screw terminals		
Output Protection		Unprotected outputs (according to JIS B 3502)		
Built-in Fuse		None		
Surge Suppression		None		
Other Output Protection		None		
Number of Outputs		8 points		
Output Signal Indication		One LED indicator for each output; lit when output is ON. Status saved in internal logic.		
Status Indication		External power supply normal: RUN indicator lit. Data being transmitted: TX indicator lit.		
Output Circuit Isolation	Isolation Method	Relay		
	Dielectric Strength	1,500 VAC for 1 minute between output terminals and internal circuits		
	Insulation Resistance	100 MΩ min. at 500 VDC between output terminals and internal circuits (at room temperature and humidity)		
External Power Supply		100/200 VAC or 24 VDC supplied to drive loads Main external power supply: 24 VDC (20.4 to 26.4 VDC), 100 mA when all outputs are ON	100/200 VAC or 24 VDC supplied to drive loads Main external power supply: 24 VDC (20.4 to 26.4 VDC), 90 mA when all outputs are ON	
Derating Conditions		The maximum ambient operating temperature is limited with some mounting directions. Refer to 3.1.2 <i>Mounting Orientation</i> for details.		
Maximum Heating Value		2.64 W	2.16 W	
Hot Swapping		Terminal block: Not permitted Communication connector: Permitted		
Mass		Approx. 300 g		
Dimensions (mm)		152 × 44 × 71.8 (W × H × D)		

3.2.3 Circuit Configuration

⚠ CAUTION

- Connect a fuse appropriate for the load specifications in series with the load. The Relay Contact 8-point Output Module is not equipped with a built-in fuse.
There is a risk of fire, damage to the load equipment, or damage to the output circuits if there is a load short-circuit or overload.

The following illustration shows the circuit configuration.

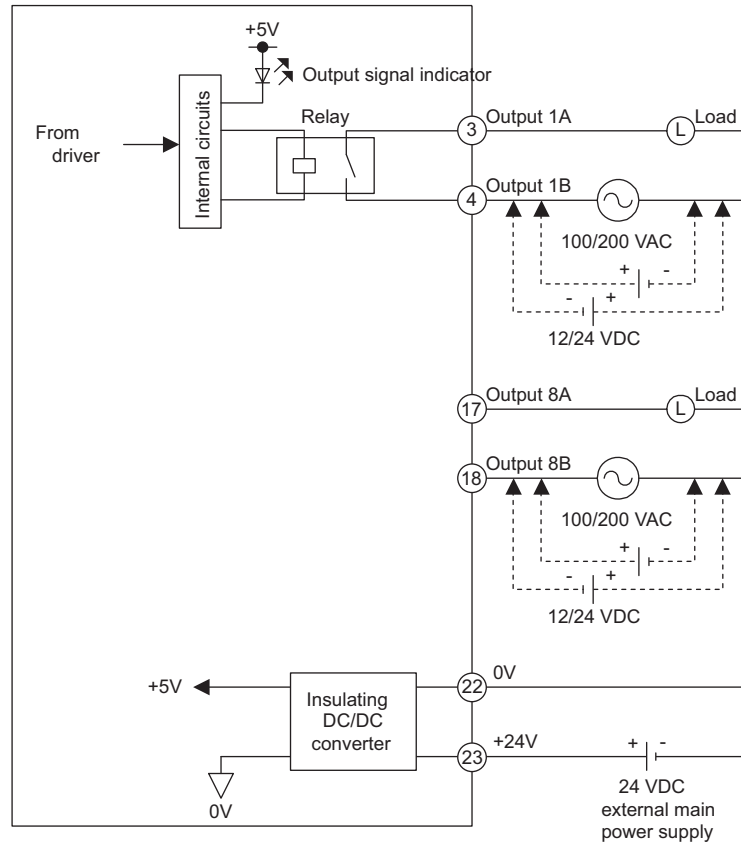

3.2.4 Connection Example

⚠ CAUTION

- Connect a fuse appropriate for the load specifications in series with the load. The Relay Contact 8-point Output Module is not equipped with a built-in fuse.
There is a risk of fire, damage to the load equipment, or damage to the output circuits if there is a load short-circuit or overload.

The following illustration shows the circuit configuration.

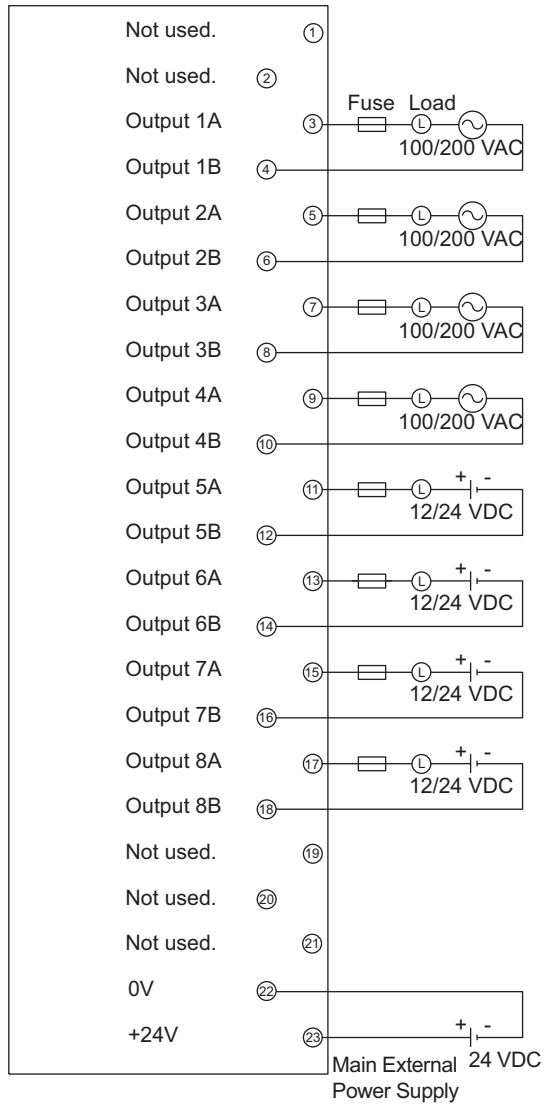

Note: Terminals 2, 19, 20, and 21 are not used.
Do not connect anything to terminal 1.

IMPORTANT

- Use crimp terminals that fit M3 screws for terminal block wiring.
- Use wire with the following gauge when connecting wire to the terminal block.
20 AWG (0.5 mm²) to 16 AWG (1.25 mm²)
For the common wire, use wire with 16 AWG (1.25 mm²) or more.

3.2.5 I/O Allocations

The leading register number of the I/O registers used by the Relay Contact 8-point Output Module is set in the I/O Assignment Tab Page in the MECHATROLINK definitions window.

Refer to *Chapter 2 I/O Allocations* for details on allocating I/O to MECHATROLINK Modules.

The following example shows how 8 output coils are allocated from OW0010.

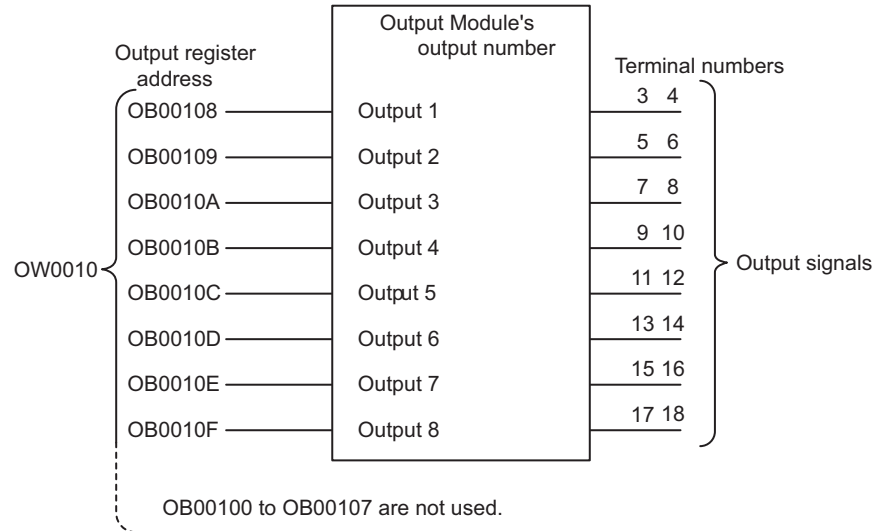

Note: The bits that are actually output are the most significant 8 bits of the set output register.

3.3 100-VAC 8-point Input Module (120DAI53330)

 CAUTION

- Do not change the DIP switch settings while a Digital I/O Module is operating. New settings on the Digital I/O Module's DIP switch become effective as soon as they are changed. Change the DIP switch settings only when the Module's main external power supply (24 VDC) is OFF. Changing the Module's DIP switch settings during operation may cause the Module to malfunction.

3.3.1 External Appearance and Configuration

The following diagram shows the 100-VAC 8-point Input Module's external parts.

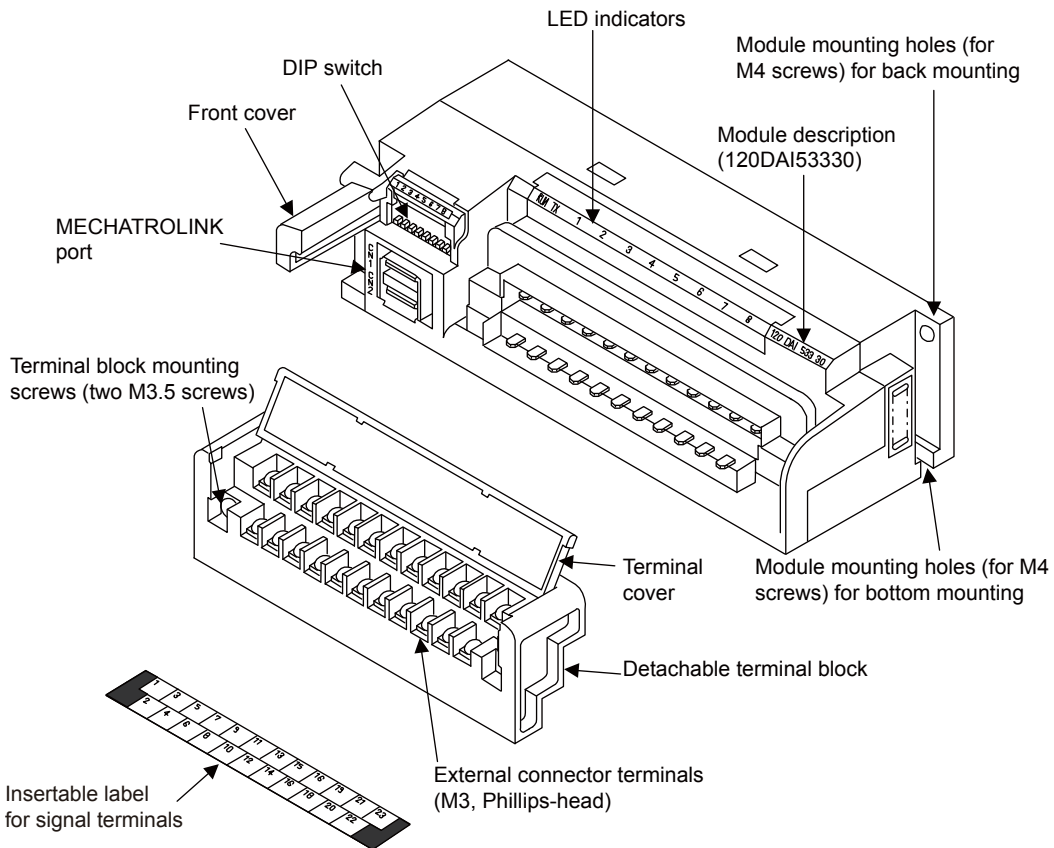

(1) LED Indicators

RUN	TX	1	2	3	4	5	6	7	8
-----	----	---	---	---	---	---	---	---	---

Indicator Name	Indicator Color	Meaning When Lit
RUN	Green	The external power is being supplied normally.
TX	Green	Sending data.
1 to 8	Green	The corresponding indicator is lit when that input signal is ON.

(2) DIP Switch

Before using the 100 VAC 8-point Input Module, the settings for the DIP switch on the front of the Module must be made.

(a) DIP Switch Functions

The DIP switch consists of eight pins. The pins are numbered 1 to 8, as shown in the following diagram. Each pin is turned to ON when it is moved to the upper position.

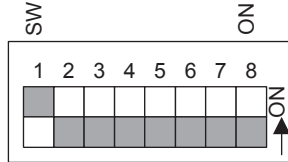

The setting of each pin becomes effective as soon the DIP switch it is changed.

The following table shows the functions that correspond to the settings for each pin.

Pin No.	Setting	Function	Factory Setting
1 to 5	ON	Set the slave address of pins 1 through 5. For details, refer to (b) <i>Slave Address Settings</i> .	1: ON 2 to 5: OFF
	OFF		
6	ON	Set the baud rate to 1 Mbps.	OFF
	OFF	Set the baud rate to 4 Mbps.	
7	ON	If the Digital Input Module is used, leave pin 7 in the OFF position.	OFF
	OFF		
8	ON	Reserved for future use. Leave pin 8 in the OFF position.	OFF
	OFF		

(b) Slave Address Settings

Set the slave address with pins 1 to 5 on the DIP switch on the front of the Distributed I/O Module.

Refer to the following table, and set the slave addresses as required.

Pin No.					Slave Address
1	2	3	4	5	
0	0	0	0	0	Not used
1	0	0	0	0	1
0	1	0	0	0	2
1	1	0	0	0	3
0	0	1	0	0	4
1	0	1	0	0	5
0	1	1	0	0	6
1	1	1	0	0	7
0	0	0	1	0	8
1	0	0	1	0	9
0	1	0	1	0	10
1	1	0	1	0	11
0	0	1	1	0	12
1	0	1	1	0	13
0	1	1	1	0	14
1	1	1	1	0	15
0	0	0	0	1	16
1	0	0	0	1	17
0	1	0	0	1	18
1	1	0	0	1	19
0	0	1	0	1	20
1	0	1	0	1	21
0	1	1	0	1	22
1	1	1	0	1	23
0	0	0	1	1	24
1	0	0	1	1	25
0	1	0	1	1	26
1	1	0	1	1	27
0	0	1	1	1	28
1	0	1	1	1	29
0	1	1	1	1	30
1	1	1	1	1	Not used

IMPORTANT

- The maximum number of slave stations depends on the method used for MECHATROLINK communication. Confirm the number of slave stations, and set the number of stations to a value that is equal to or less than the number of stations available.
- Do not duplicate a slave address within one communication circuit. Distributed I/O modules with duplicate slave addresses will not communicate correctly with each other or other devices.
- A new slave address set with pins 1 to 5 becomes effective as soon as the DIP switch is changed.

3.3.2 Performance Specifications

The performance specifications of 100-VAC 8-point Input Module are shown below.

Item		Specifications
Name		100-VAC 8-point Input Module
Model Description		V_AC100IN-8P
Model Number		JAMSC-120DAI53330
Rated Voltage		100 VAC
Maximum Allowable Voltage		132 VAC
Rated Frequency		50 or 60Hz
Allowable Frequency Range		47 to 63 Hz
Inrush Current		160 mA
Rated Current		7 mA (100 VAC, 50Hz)
Input Impedance		14.3 k Ω (50 Hz) 12.5 k Ω (60 Hz)
Standard Operating Ranges		ON voltage range: 74 to 132 VAC OFF voltage range: 30 VAC max.
Input Type		AC type 2 (according to JIS B 3501)
Input Delay Times		OFF to ON: 20 ms max. ON to OFF: 35 ms max.
Number of Commons		1
Number of Inputs per Common		8 points/common
External Connections		Removable terminal block with 23 M3 screw terminals
Number of Inputs		8 points
Input Signal Indication		One LED indicator for each input; lit when input is ON. Status saved in internal logic.
Status Indication		External power supply normal: RUN in indicator lit. Data being transmitted: TX indicator lit.
Input Circuit Isolation	Isolation Method	Photocoupler
	Dielectric Strength	1,500 VAC for 1 minute between input terminals and internal circuits
	Insulation Resistance	100 M Ω min. at 500 VDC between input terminals and internal circuits (at room temperature and humidity)
External power supply		Input signal power supply: 100 VAC Main external power supply: 24 VDC (20.4 to 26.4 VDC), 80 mA max. when all inputs are ON
Derating Conditions		The maximum ambient operating temperature is limited with some mounting directions. Refer to <i>3.1.2 Mounting Orientation</i> for details.
Maximum Heating Value		1.92 W
Hot Swapping		Terminal block: Not permitted Communication connector: Permitted
Mass		Approx. 300 g
Dimensions (mm)		152 × 44 × 71.8 (W × H × D)

3.3.3 Circuit Configuration

The following illustration shows the circuit configuration for the 100-VAC 8-point Input Module.

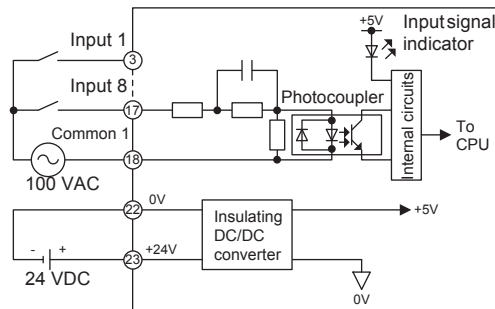

3.3.4 Connection Example

The following illustration shows an example of terminal connections for the 100-VAC 8-point Input Module.

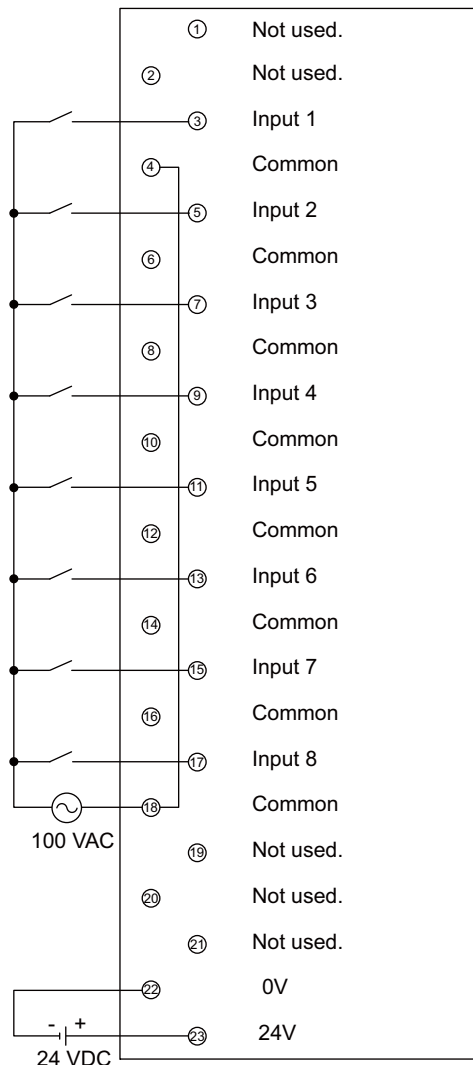

Note: 1. Terminals 4, 6, 8, 10, 12, 14, 16, and 18 are connected internally.

2. Terminals 2, 19, 20, and 21 are not used.

3. Do not connect anything to terminal 1.

IMPORTANT

- Use crimp terminals that fit M3 screws for terminal block wiring.
- Use wire with the following gauge when connecting wire to the terminal block.
20 AWG (0.5 mm²) to 16 AWG (1.25 mm²)

3.3.5 I/O Allocations

The leading register number of the I/O registers used by the 100-VAC 8-point Input Module is set in the I/O Assignment Tab in the MECHATROLINK definitions window.

Refer to *Chapter 2 I/O Allocations* for details on allocating I/O to MECHATROLINK Modules.

The following example shows how 8 input relays are allocated from IW0010.

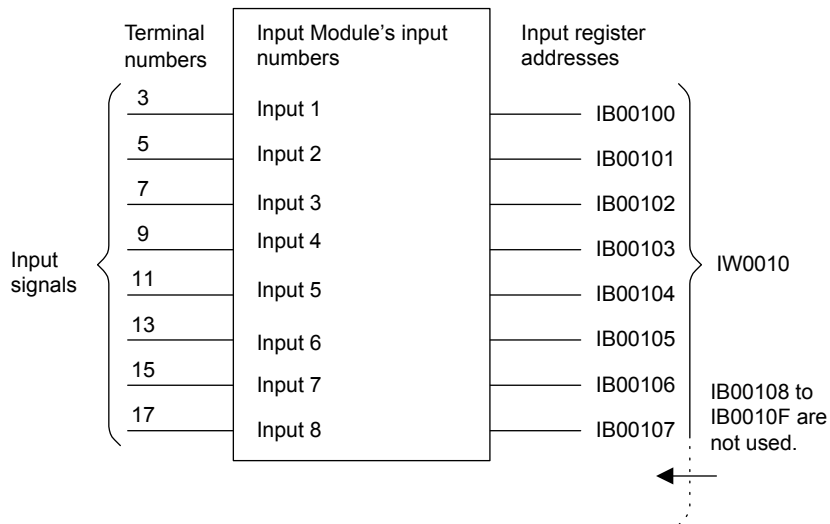

3.4 200-VAC 8-point Input Module (120DAI73330)

3.4.1 External Appearance and Configuration

The following diagram shows the 200-VAC 8-point Input Module's external parts.

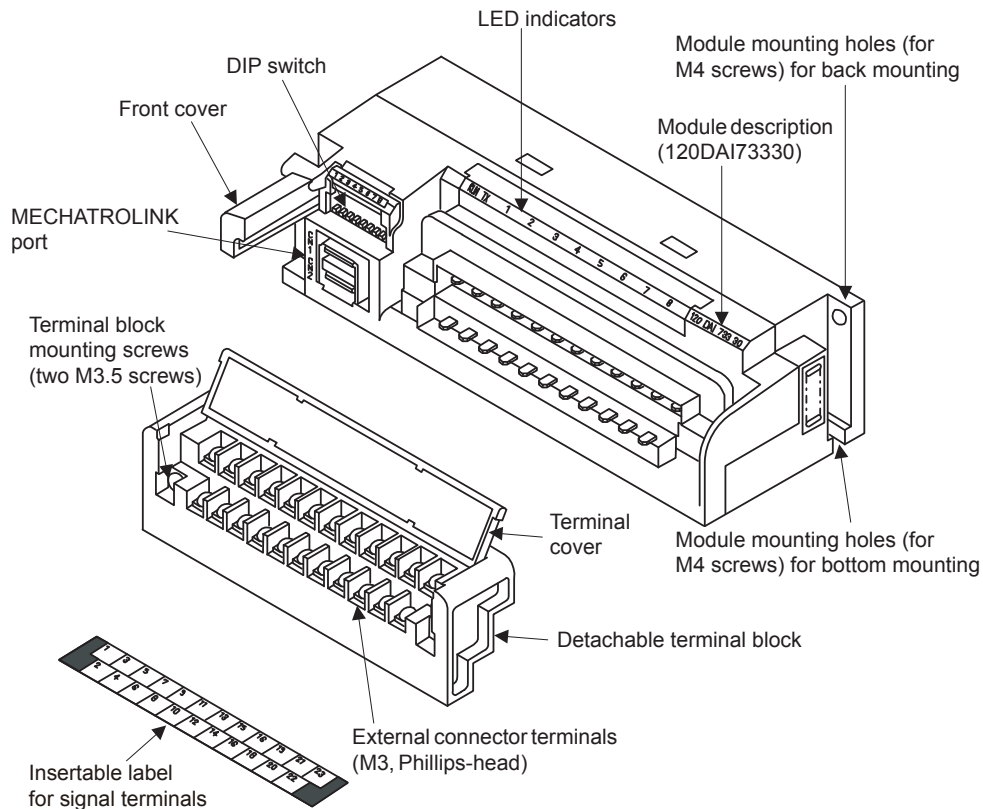

(1) LED Indicators

RUN	TX	1	2	3	4	5	6	7	8
-----	----	---	---	---	---	---	---	---	---

Indicator Name	Indicator Color	Meaning When Lit
RUN	Green	The external power is being supplied normally.
TX	Green	Sending data.
1 to 8	Green	The corresponding indicator is lit when that input signal is ON.

(2) DIP Switch

Before using the 200 VAC 8-point Input Module, the settings for the DIP switch on the front of the Module must be made.

(a) DIP Switch Functions

The DIP switch consists of eight pins. The pins are numbered 1 to 8, as shown in the following diagram. Each pin is turned to ON when it is moved to the upper position.

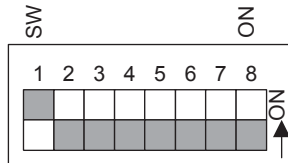

The setting of each pin becomes effective as soon as the DIP switch is changed.

The following table shows the functions that correspond to the settings for each pin.

Pin No.	Setting	Function	Factory Setting
1 to 5	ON	Set the slave address of pins 1 through 5. For details, refer to <i>(b) Slave Address Settings</i> .	1: ON 2 to 5: OFF
	OFF		
6	ON	Set the baud rate to 1 Mbps.	OFF
	OFF	Set the baud rate to 4 Mbps.	
7	ON	If the Digital Input Module is used, leave pin 7 in the OFF position.	OFF
	OFF		
8	ON	Reserved for future use. Leave pin 8 in the OFF position.	OFF
	OFF		

(b) Slave Address Settings

Set the slave address with pins 1 to 5 on the DIP switch on the front of the Distributed I/O Module.

Refer to the following table, and set the slave addresses as required.

Pin No.					Slave Address
1	2	3	4	5	
0	0	0	0	0	Not used
1	0	0	0	0	1
0	1	0	0	0	2
1	1	0	0	0	3
0	0	1	0	0	4
1	0	1	0	0	5
0	1	1	0	0	6
1	1	1	0	0	7
0	0	0	1	0	8
1	0	0	1	0	9
0	1	0	1	0	10
1	1	0	1	0	11
0	0	1	1	0	12
1	0	1	1	0	13
0	1	1	1	0	14
1	1	1	1	0	15
0	0	0	0	1	16
1	0	0	0	1	17
0	1	0	0	1	18
1	1	0	0	1	19
0	0	1	0	1	20
1	0	1	0	1	21
0	1	1	0	1	22
1	1	1	0	1	23
0	0	0	1	1	24
1	0	0	1	1	25
0	1	0	1	1	26
1	1	0	1	1	27
0	0	1	1	1	28
1	0	1	1	1	29
0	1	1	1	1	30
1	1	1	1	1	Not used

IMPORTANT

- The maximum number of slave stations depends on the method used for MECHATROLINK communication. Confirm the number of slave stations, and set the number of stations to a value that is equal to or less than the number of stations available.
- Do not duplicate a slave address within one communication circuit. Distributed I/O modules with duplicate slave addresses will not communicate correctly with each other or other devices.
- A new slave address set with pins 1 to 5 becomes effective as soon as the DIP switch is changed.

3.4.2 Performance Specifications

The performance specifications of 200-VAC 8-point Input Module are shown below.

Item		Specifications
Name		200-VAC 8-point Input Module
Model Description		V_AC200IN-8P
Model Number		JAMSC-120DAI73330
Rated Voltage		200 VAC
Maximum Allowable Voltage		264 VAC
Rated Frequency		50 or 60Hz
Allowable Frequency Range		47 to 63 Hz
Inrush Current		320 mA
Rated Current		7 mA (200 VAC, 50Hz)
Input Impedance		28.6 kΩ (50 Hz) 23.1 kΩ (60 Hz)
Standard Operating Ranges		ON voltage range: 159 to 264 VAC OFF voltage range: 40 VAC max.
Input Type		AC type 2 (according to JIS B 3501)
Input Delay Times		OFF to ON: 20 ms max. ON to OFF: 35 ms max.
Number of Commons		1
Number of Inputs per Common		8 points/common
External Connections		Removable terminal block with 23 M3 screw terminals
Number of Inputs		8 points
Input Signal Indication		One LED Indicator for each input; lit when input is ON. Status saved in internal logic.
Status Indication		External power supply normal: RUN indicator lit. Data being transmitted: TX indicator lit.
Input Circuit Isolation	Isolation Method	Photocoupler
	Dielectric Strength	1,500 VAC for 1 minute between input terminals and internal circuits
	Insulation Resistance	100 MΩ min. at 500 VDC between input terminals and internal circuits (at room temperature and humidity)
External Power Supply		Input signal power supply: 200 VAC Main external power supply: 24 VDC (20.4 to 26.4 VDC), 80 mA max. when all inputs are ON
Derating Conditions		The maximum ambient operating temperature is limited with some mounting directions. Refer to 3.1.2 <i>Mounting Orientation</i> for details.
Maximum Heating Value		1.92 W
Hot Swapping		Terminal block: Not permitted Communication connector: Permitted
Mass		Approx. 300 g
Dimensions (mm)		152 × 44 × 71.8 (W × H × D)

3.4.3 Circuit Configuration

The following illustration shows the circuit configuration for the 200-VAC 8-point Input Module.

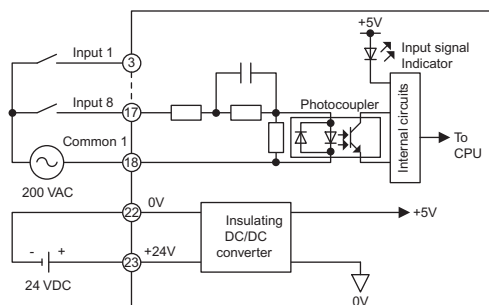

3.4.4 Connection Example

The following illustration shows an example of terminal connections for the 200-VAC 8-point Input Module.

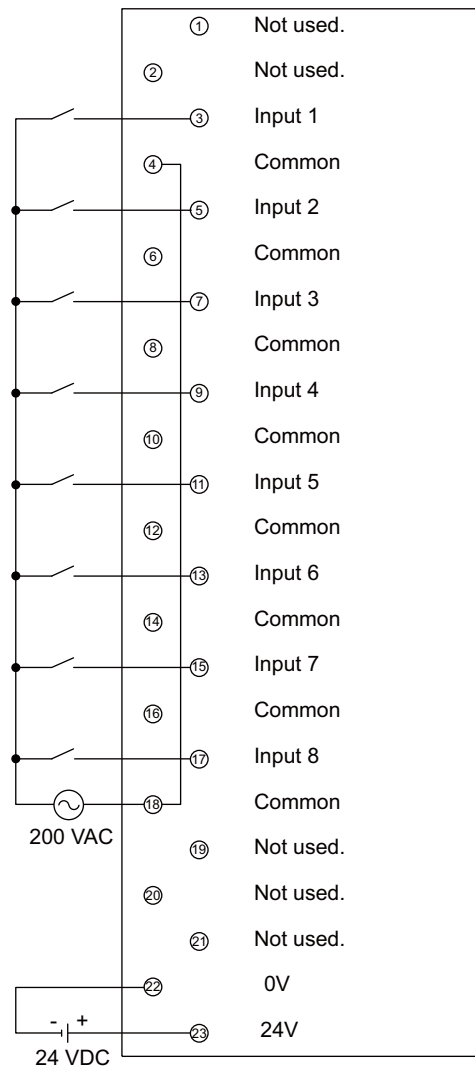

Note: 1. Terminals 4, 6, 8, 10, 12, 14, 16, and 18 are connected internally.

2. Terminals 2, 19, 20, and 21 are not used.

3. Do not connect anything to terminal 1.

IMPORTANT

- Use crimp terminals that fit M3 screws for terminal block wiring.
- Use wire with the following gauge when connecting wire to the terminal block.
20 AWG (0.5 mm²) to 16 AWG (1.25 mm²)

3.4.5 I/O Allocations

The leading register number of the I/O registers used by the 200-VAC 8-point Input Module is set in the I/O Assignment Tab in the MECHATROLINK definitions window.

Refer to *Chapter 2 I/O Allocations* for details on allocating I/O to MECHATROLINK Modules.

The following example shows how 8 input relays are allocated from IW0010.

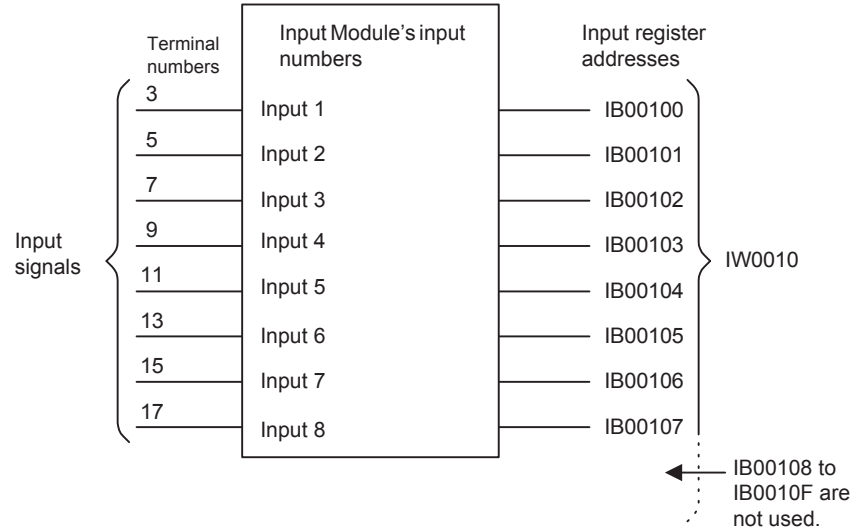

3.5 100/200-VAC 8-point Output Module (120DAO83330)

3.5.1 External Appearance and Configuration

The following diagram shows the 100/200-VAC 8-point Output Module's external parts.

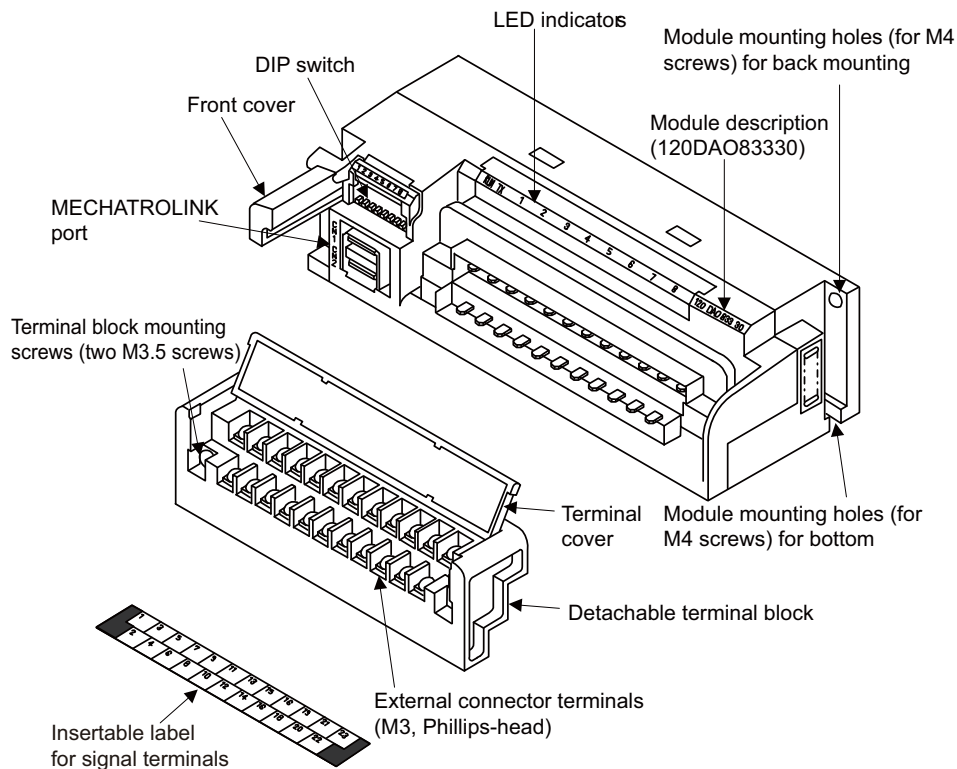

(1) LED Indicators

RUN	TX	ERR	1	2	3	4	5	6	7	8
-----	----	-----	---	---	---	---	---	---	---	---

Indicator Name	Indicator Color	Meaning When Lit
RUN	Green	The external power is being supplied normally.
TX	Green	Sending data.
ERR	Red	Blown fuse or disconnected load power supply
1 to 8	Green	The corresponding indicator is lit when that output signal is ON.

(2) DIP Switch

Before using the 100/200 VAC 8-point Output Module, the settings for the DIP switch on the front of the Module must be made.

(a) DIP Switch Functions

The DIP switch consists of eight pins. The pins are numbered 1 to 8, as shown in the following diagram. Each pin is turned to ON when it is moved to the upper position.

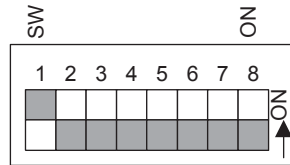

The setting of each pin becomes effective as soon as the DIP switch is changed.

The following table shows the functions that correspond to the settings for each pin.

Pin No.	Setting	Function	Factory Setting
1 to 5	ON	Set the slave address of pins 1 through 5. For details, refer to <i>(b) Slave Address Settings</i> .	1: ON 2 to 5: OFF
	OFF		
6	ON	Set the baud rate to 1 Mbps.	OFF
	OFF	Set the baud rate to 4 Mbps.	
7	ON	With a Digital Output Module, the user can select the status of output data when communication is stopped. This setting retains the status of the outputs that existed before communication stopped.	OFF
	OFF	With a Digital Output Module, the user can select the status of output data when communication is stopped. This setting turns OFF all outputs when communication stops.	OFF
8	ON	Reserved for future use. Leave pin 8 in the OFF position.	OFF
	OFF		

(b) Slave Address Settings

Set the slave address with pins 1 to 5 on the DIP switch on the front of the Distributed I/O Module. Refer to the following table, and set the slave addresses as required.

Pin No.					Slave Address
1	2	3	4	5	
0	0	0	0	0	Not used
1	0	0	0	0	1
0	1	0	0	0	2
1	1	0	0	0	3
0	0	1	0	0	4
1	0	1	0	0	5
0	1	1	0	0	6
1	1	1	0	0	7
0	0	0	1	0	8
1	0	0	1	0	9
0	1	0	1	0	10
1	1	0	1	0	11
0	0	1	1	0	12
1	0	1	1	0	13
0	1	1	1	0	14
1	1	1	1	0	15
0	0	0	0	1	16
1	0	0	0	1	17
0	1	0	0	1	18
1	1	0	0	1	19
0	0	1	0	1	20
1	0	1	0	1	21
0	1	1	0	1	22
1	1	1	0	1	23
0	0	0	1	1	24
1	0	0	1	1	25
0	1	0	1	1	26
1	1	0	1	1	27
0	0	1	1	1	28
1	0	1	1	1	29
0	1	1	1	1	30
1	1	1	1	1	Not used

IMPORTANT

- The maximum number of slave stations depends on the method used for MECHATROLINK communication. Confirm the number of slave stations, and set the number of stations to a value that is equal to or less than the number of stations available.
- Do not duplicate a slave address within one communication circuit. Distributed I/O modules with duplicate slave addresses will not communicate correctly with each other or other devices.
- A new slave address set with pins 1 to 5 becomes effective as soon as the DIP switch is changed.

3.5.2 Performance Specifications

The performance specifications of 100/200-VAC 8-point Output Module are shown below.

Item	Specifications	
Name	100/200-VAC 8-point Output Module	
Model Description	V_ACOUT-8P	
Model Number	JAMSC-120DAO83330	
Rated Voltage	100/200 VAC	
Allowable Voltage Range	80 to 264 VAC	
Rated Frequency	50 or 60 Hz	
Allowable Frequency Range	47 to 63 Hz	
Maximum Load Current	0.6 Arms/point, 2.4 A/common	
Output Voltage Drop	1.0 V rms	
Output Delay Times	OFF to ON: 10 ms max. ON to OFF: $\frac{1}{2}$ cycle + 5 ms max.	
Leakage Current when OFF	2 mA max. at 240 VAC, 50 Hz	
Minimum Switching Voltage/Current	10 mA rms	
Output Type	Triac outputs	
Number of Commons	1	
External Connections	Removable terminal block with M3 screw terminals	
Output Protection Type	Unprotected outputs (according to JIS B 3501)	
Built-in Fuse	One 3-A fuse (1 fuse/common) (Opening time: 1 second max. at 200% of rated current)	
Surge Suppression	Varistor	
Other Output Protection	None	
Number of Outputs	8 points	
Output Signal Indication	One LED indicator for each output; lit when output is ON. Status saved in internal logic.	
Status Indication	External power supply normal: RUN indicator lit. Data being transmitted: TX indicator lit. Blown fuse or load power supply disconnected: ERR indicator lit.	
Output Circuit Isolation	Isolation Method	Phototriac
	Dielectric Strength	1,500 VAC for 1 minute between output terminals and internal circuits.
	Insulation Resistance	100 M Ω min. at 500 VDC between input terminals and internal circuits (at room temperature and humidity)
External Power Supply	100/200 VAC supplied to drive loads Main external power supply: 24 VDC (20.4 to 26.4 VDC), 100 mA when all outputs are ON	
Derating Conditions	The maximum ambient operating temperature is limited with some mounting directions. Refer to 3.1.2 <i>Mounting Orientation</i> for details.	
Maximum Heating Value	2.4 W	
Hot Swapping	Terminal block: Not permitted Communication connector: Permitted	
Mass	Approx. 300 g	
Dimensions (mm)	152 × 44 × 71.8 (W × H × D)	

3.5.3 Circuit Configuration

 CAUTION

- Built-in fuse do not protect the output elements. Connect a fuse appropriate for the load specifications in series with the load.
There is a risk of fire, damage to the load equipment, or damage to the output circuits if there is a load short-circuit or overload.
- The customer must not replace the built-in fuse.
There is a risk of output module accident or malfunction. Also any failures caused by ignoring this caution will invalidate the guarantee. Yaskawa replaces built-in fuse.

The following illustration shows the circuit configuration for the 100/200-VAC 8-point Output Module.

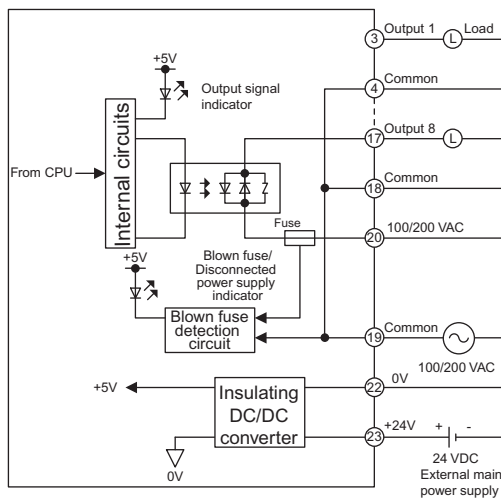

IMPORTANT Communication with the master will stop when the load power supply is OFF or the fuse blows.

3.5.4 Connection Example

⚠ CAUTION

- Built-in fuse do not protect the output elements. Connect a fuse appropriate for the load specifications in series with the load.
There is a risk of fire, damage to the load equipment, or damage to the output circuits if there is a load short-circuit or overload.

The following illustration shows an example of terminal connections for the 100/200-VAC 8-point Output Module.

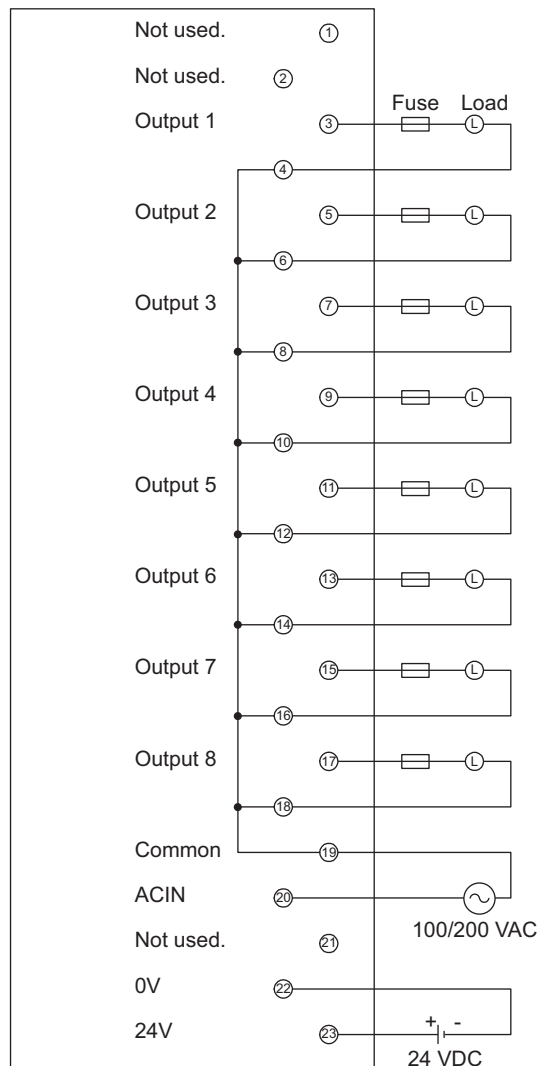

- Note:
1. Terminals 4, 6, 8, 10, 12, 14, 16, 18, and 19 are connected internally.
 2. Terminals 2 and 21 are not used.
 3. Do not connect anything to terminal 1.

IMPORTANT

- Use crimp terminals that fit M3 screws for terminal block wiring.
- Use wire with the following gauge when connecting wire to the terminal block.
20 AWG (0.5 mm²) to 16 AWG (1.25 mm²)
For the common wire, use wire with 16 AWG (1.25 mm²) or more.

3.5.5 I/O Allocations

The leading register number of the I/O registers used by the 100/200-VAC 8-point Output Module is set in the I/O Assignment Tab in the MECHATROLINK definitions window.

Refer to *Chapter 2 I/O Allocations* for details on allocating I/O to MECHATROLINK Modules.

The following example shows how 8 output coils are allocated from OW0010.

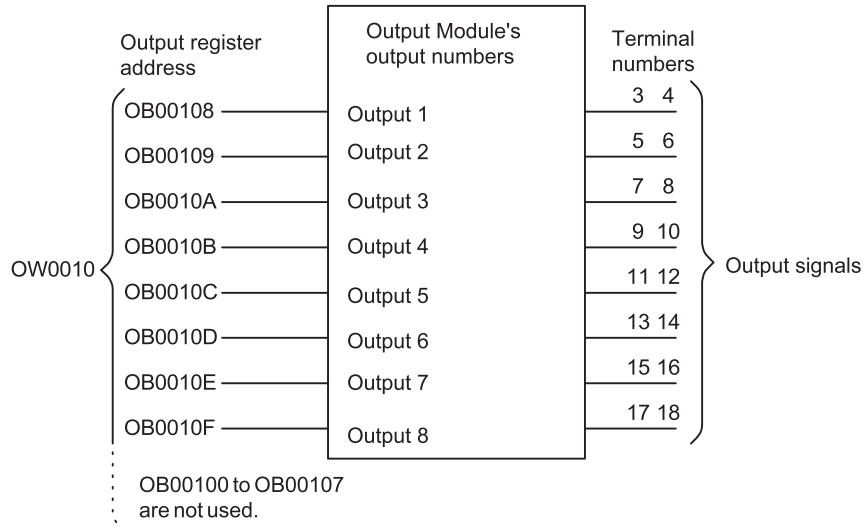

Note: The bits that are actually output are the most significant 8 bits of the set output register.

3.6 24-VDC 8-point I/O Module (IO2920)

3.6.1 External Appearance and Configuration

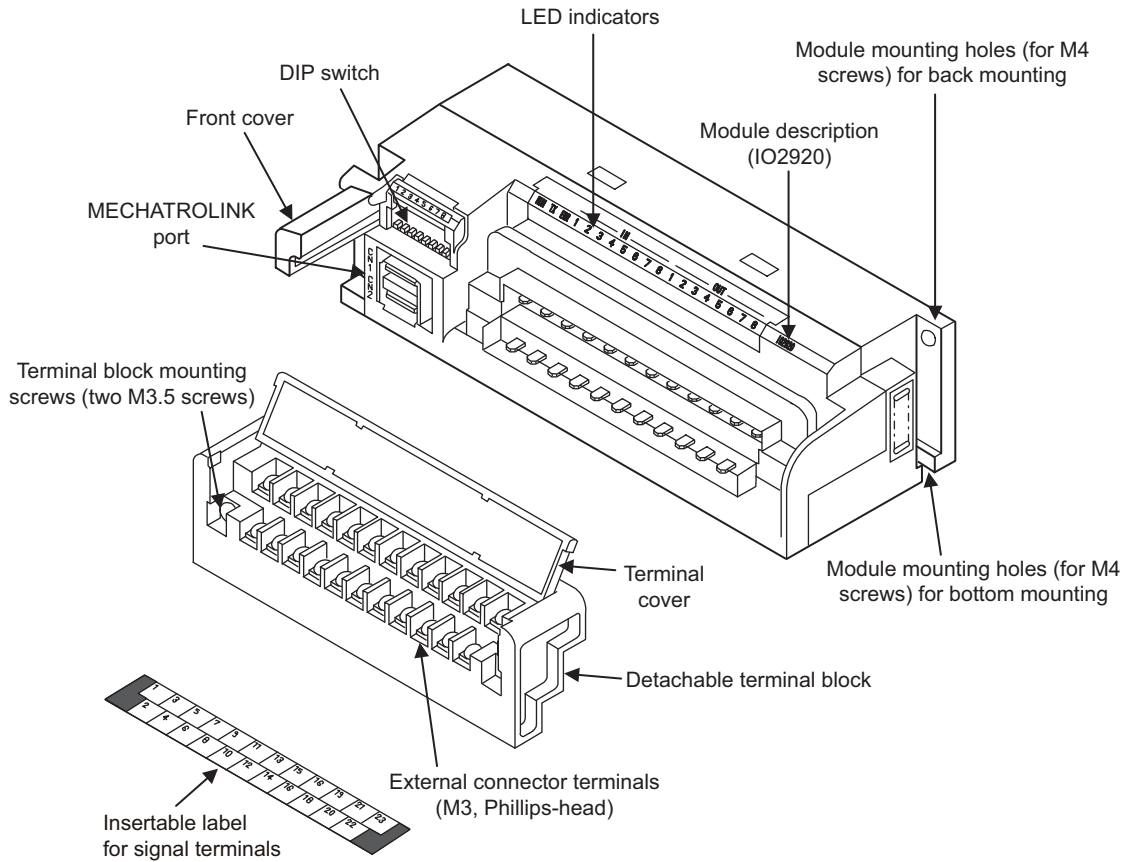

(1) LED Indicators

_____ IN _____ OUT _____		
Indicator Name	Indicator Color	Meaning When Lit
RUN TX ERR 1 2 3 4 5 6 7 8 1 2 3 4 5 6 7 8		
RUN	Green	The external power is being supplied normally.
TX	Green	Sending data.
ERR	Red	Blown fuse.
IN 1 to 8	Green	The corresponding indicator is lit when that input signal is ON.
OUT 1 to 8	Green	The corresponding indicator is lit when that output signal is ON.

(2) DIP Switch

Before using the 24-VDC 8-point I/O Module, the settings for the DIP switch on the front of the Module must be made.

(a) DIP Switch Functions

The DIP switch consists of eight pins. The pins are numbered 1 to 8, as shown in the following diagram. Each pin is turned to ON when it is moved to the upper position.

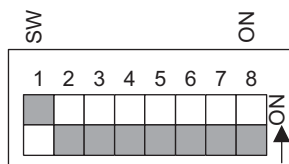

The setting of each pin becomes effective as soon as the DIP switch is changed. The following table shows the functions that correspond to the settings for each pin.

Pin No.	Setting	Function	Factory Setting
1 to 5	ON	Set the slave address of pins 1 through 5. For details, refer to (b) <i>Slave Address Settings</i> .	1: ON 2 to 5: OFF
	OFF		
6	ON	Set the communication type to 32 Bytes.	OFF
	OFF	Set the communication type to 17 Bytes.	
7	ON	The user can select the status of output data when communication is stopped. This setting retains the status of the outputs that existed before communication stopped.	OFF
	OFF	The user can select the status of output data when communication is stopped. This setting turns OFF all outputs when communication stops.	
8	ON	Set the baud rate to 10 Mbps.	OFF
	OFF	Set the baud rate to 4 Mbps.	

(b) Slave Address Settings

Set the slave address with pins 1 to 5 on the DIP switch on the front of the Distributed I/O Module. Refer to the following table, and set the slave addresses as required.

Pin No.					Slave Address	Pin No.					Slave Address
1	2	3	4	5		1	2	3	4	5	
0	0	0	0	0	Not used	0	0	0	0	1	16
1	0	0	0	0	1	1	0	0	0	1	17
0	1	0	0	0	2	0	1	0	0	1	18
1	1	0	0	0	3	1	1	0	0	1	19
0	0	1	0	0	4	0	0	1	0	1	20
1	0	1	0	0	5	1	0	1	0	1	21
0	1	1	0	0	6	0	1	1	0	1	22
1	1	1	0	0	7	1	1	1	0	1	23
0	0	0	1	0	8	0	0	0	1	1	24
1	0	0	1	0	9	1	0	0	1	1	25
0	1	0	1	0	10	0	1	0	1	1	26
1	1	0	1	0	11	1	1	0	1	1	27
0	0	1	1	0	12	0	0	1	1	1	28
1	0	1	1	0	13	1	0	1	1	1	29
0	1	1	1	0	14	0	1	1	1	1	30
1	1	1	1	0	15	1	1	1	1	1	Not used

IMPORTANT

- The maximum number of slave stations depends on the method used for MECHATROLINK communication. Confirm the number of slave stations, and set the number of stations to a value that is equal to or less than the number of stations available.
- Do not duplicate a slave address within one communication circuit. Distributed I/O modules with duplicate slave addresses will not communicate correctly with each other or other devices.
- A new slave address set with pins 1 to 5 becomes effective as soon as the DIP switch is changed.

3.6.2 Performance Specifications

The performance specifications of 24-VDC 8-point I/O Module are shown below.

Item		Specifications
Name		24-VDC 8-point I/O Module
Model Description		IO2920
Model Number		JAMSC-IO2920-E
Rated Voltage		12 or 24 VDC
Maximum Allowable Voltage		10.2 to 30.0 VDC
Input Specifications	Input Format	Sinking or sourcing
	Rated Current	12 VDC: 2.5 mA 24 VDC: 5.0 mA
	Input Impedance	4.8 kΩ
	Standard Operating Ranges	Minimum ON voltage: 9 VDC Maximum OFF voltage: 5 VDC
	Input Type	12 VDC: Not compliant with JIS B 3502 standards 24 VDC: DC type 2 (according to JIS B 3502)
	Input Delay Times	OFF to ON: 5 ms max. ON to OFF: 5 ms max.
	Number of Commons	1
	Number of Inputs per Common	8 points/common
	Number of Inputs	8 points
Output Specifications	Output Format	Sinking
	Maximum Load Current	0.3 A/point
	Output Voltage Drop	1.5 V max. (0.3 A)
	Output Delay Times	OFF to ON: 1 ms max. ON to OFF: 1 ms max.
	Leakage Current when OFF	1 mA max. at 24 VDC
	Output Type	Transistor outputs
	Number of Commons	1
	Number of Outputs per Common	8 points/common
	Output Protection Type	Unprotected outputs (according to JIS B 3502)
	Built-in Fuse	One 3.5-A fuses (1 fuse/common) (Opening time: 5 seconds max. at 200% of rated current)
	Surge Suppression	None
	Other Output Protection	None
Number of Outputs	8 points	
I/O Signal Indication		One LED indicator for each output or input; lit when output or input is ON. Status saved in internal logic.
Status Indication		External power supply normal: RUN indicator lit. Data being transmitted: TX indicator lit. Blown fuse: ERR indicator lit.

(cont'd)

Item		Specifications
Circuit Isolation	Isolation Method	Photocoupler
	Dielectric Strength	1,500 VAC for 1 minute between I/O terminals and internal circuits.
	Insulation Resistance	100 M Ω min. at 500 VDC between I/O terminals and internal circuits (at room temperature and humidity).
External Power Supply		I/O signal power supply: 12 or 24 VDC Main external power supply: 24 VDC (20.4 to 26.4 VDC), 70 mA when all outputs are ON
Derating Conditions		The maximum ambient operating temperature is limited with some mounting directions*.
Maximum Heating Value		1.68 W
External Connections		Removable terminal block with 23 M3 screw terminals
Hot Swapping		Terminal block: Not permitted Communication connector: Permitted
Mass		Approx. 300 g
Dimensions (mm)		152 \times 44 \times 71.8 (W \times H \times D)

* Refer to 3.1.2 *Mounting Orientation* for details.

3.6.3 Circuit Configuration

⚠ CAUTION

- Built-in fuse do not protect the output elements. Connect a fuse appropriate for the load specifications in series with the load.
There is a risk of fire, damage to the load equipment, or damage to the output circuits if there is a load short-circuit or overload.

The following illustration shows the circuit configuration for the 24-VDC 8-point I/O Module.

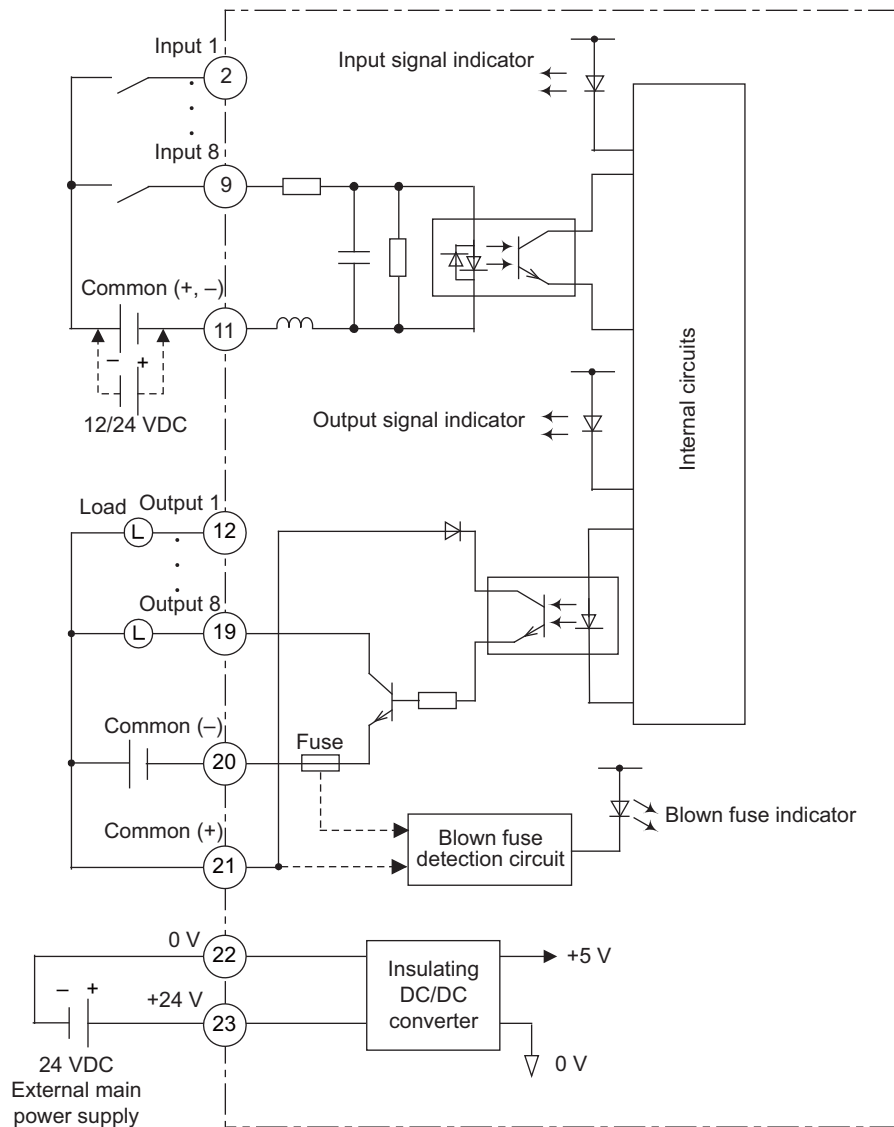

IMPORTANT

Communication with the master will stop if the fuse blows.

3.6.4 Connection Example

⚠ CAUTION

- Built-in fuse do not protect the output elements. Connect a fuse appropriate for the load specifications in series with the load.
There is a risk of fire, damage to the load equipment, or damage to the output circuits if there is a load short-circuit or overload.

The following illustration shows an example of terminal connections for the 24-VDC 8-point I/O Module.

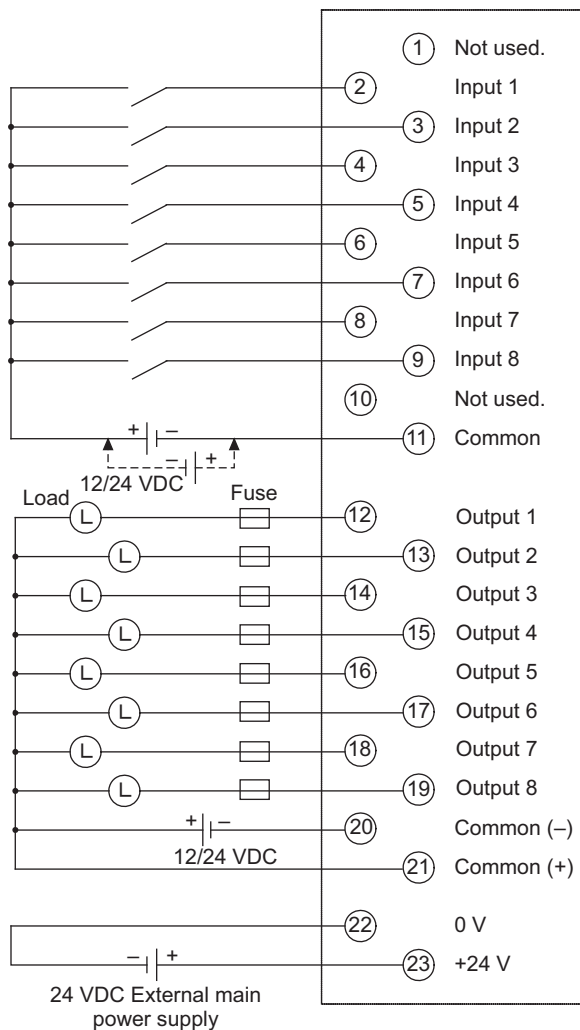

- Note: 1. Terminal 10 is not used.
2. Do not connect anything to terminal 1.

IMPORTANT

- Use crimp terminals that fit M3 screws for terminal block wiring.
- Use wire with the following gauge when connecting wire to the terminal block.
24 AWG (0.2 mm²) to 18 AWG (0.9 mm²)
- The polarity of the external input signal power supply can be connected in either direction.

3.6.5 I/O Allocations

The leading register number of the I/O registers used by the 24-VDC 8-point I/O Module is set in the I/O Assignment Tab Page in the MECHATROLINK definitions window.

Refer to *Chapter 2 I/O Allocations* for details on allocating I/O to MECHATROLINK Modules.

The following example shows how 8 output coils are allocated from OW0011 and 8 input relays are allocated from IW0010.

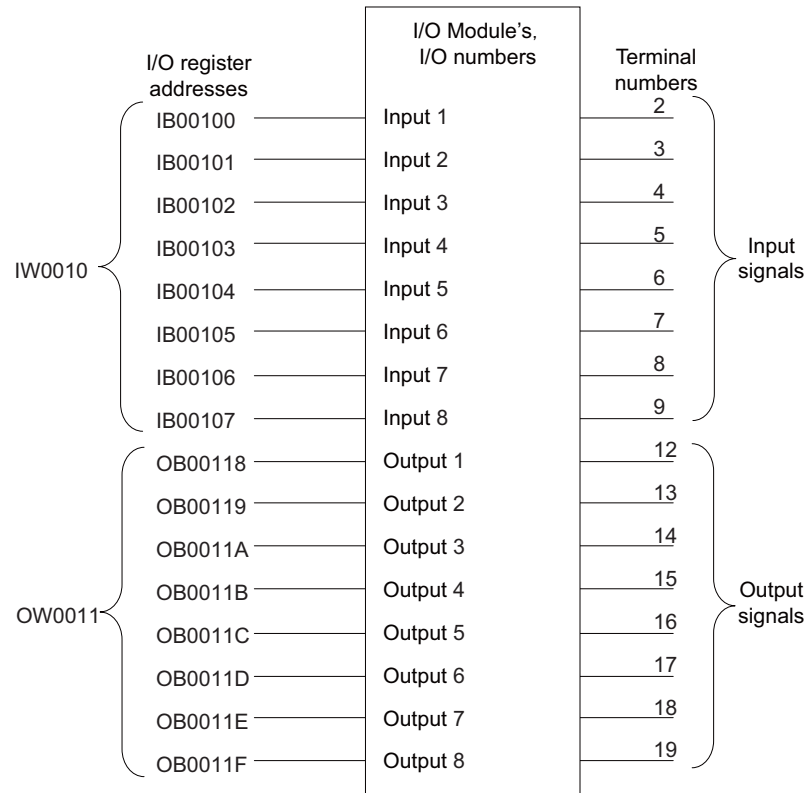

IB00108 to IB0010F and OB00110 to OB00117 are not used.

Note: Although 16-bit words are individually allocated to the I/O register, only the most significant eight bits of the register are output, and least significant eight bits of the register are input.

3.7 24-VDC 16-point Input Module (120DDI34330/IO2900)

3.7.1 External Appearance and Configuration

The following diagram shows the 24-VDC 16-point Input Module's external parts.

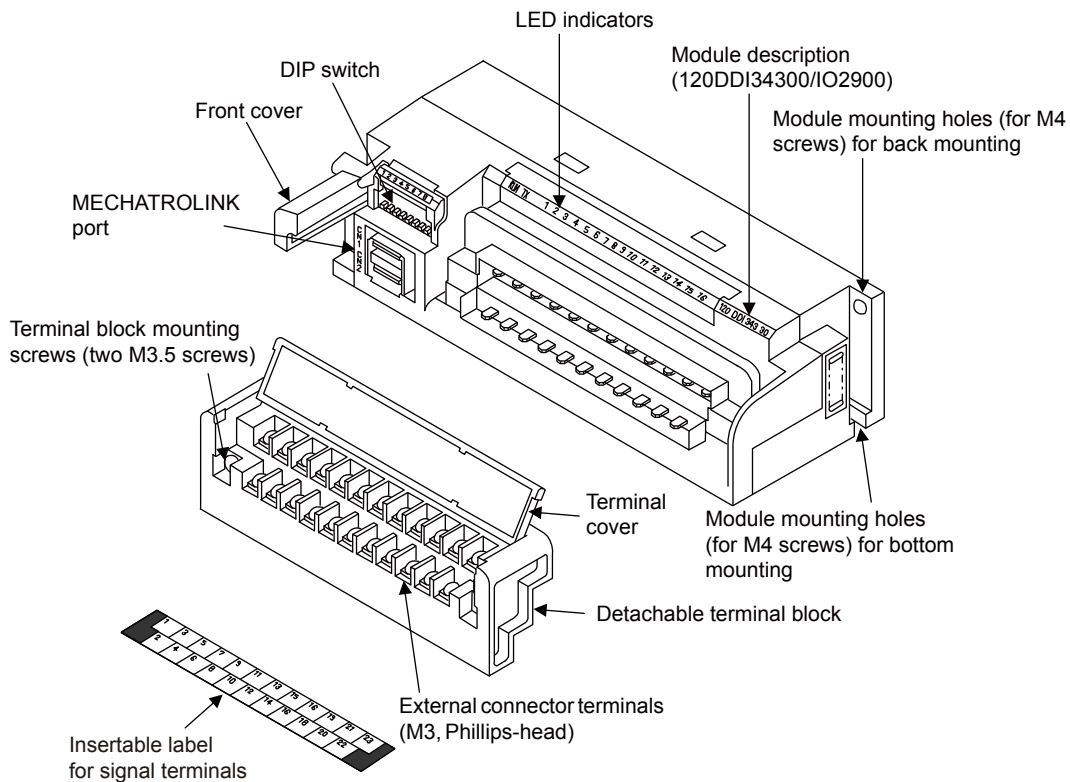

(1) LED Indicators

RUN	TX	1	2	3	4	5	6	7	8	9	10	11	12	13	14	15	16
Indicator Name	Indicator Color	Meaning When Lit															
RUN	Green	The external power is being supplied normally.															
TX	Green	Sending data.															
1 to 16	Green	The corresponding indicator is lit when that input signal is ON.															

(2) DIP Switch

Before using the 24 VDC 16-point Input Module, the settings for the DIP switch on the front of the Module must be made.

(a) DIP Switch Functions

The DIP switch consists of eight pins. The pins are numbered 1 to 8, as shown in the following diagram. Each pin is turned to ON when it is moved to the upper position.

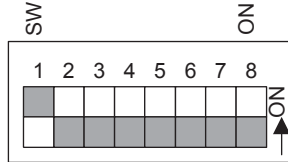

The setting of each pin becomes effective as soon as the DIP switch is changed.

The following table shows the functions that correspond to the settings for each pin.

- 120DDI34330

Pin No.	Setting	Function	Factory Setting
1 to 5	ON	Set the slave address of pins 1 through 5. For details, refer to <i>(b) Slave Address Settings</i> .	1: ON 2 to 5: OFF
	OFF		
6	ON	Set the baud rate to 1 Mbps.	OFF
	OFF	Set the baud rate to 4 Mbps.	
7	ON	If the Digital Input Modules is used, leave pin 7 in the OFF position.	OFF
	OFF		
8	ON	Reserved for future use. Leave pin 8 in the OFF position.	OFF
	OFF		

- IO2900

Pin No.	Setting	Function	Factory Setting
1 to 5	ON	Set the slave address of pins 1 through 5. For details, refer to <i>(b) Slave Address Settings</i> .	1: ON 2 to 5: OFF
	OFF		
6	ON	Set the communication data length to 32 bytes.	OFF
	OFF	Set the communication data length to 17 bytes.	
7	ON	If the Digital Input Modules is used, leave pin 7 in the OFF position.	OFF
	OFF		
8	ON	Set the baud rate to 10 Mbps.	OFF
	OFF	Set the baud rate to 4 Mbps.	

(b) Slave Address Settings

Set the slave address with pins 1 to 5 on the DIP switch on the front of the Distributed I/O Module. Refer to the following table, and set the slave addresses as required.

Pin No.					Slave Address
1	2	3	4	5	
0	0	0	0	0	Not used
1	0	0	0	0	1
0	1	0	0	0	2
1	1	0	0	0	3
0	0	1	0	0	4
1	0	1	0	0	5
0	1	1	0	0	6
1	1	1	0	0	7
0	0	0	1	0	8
1	0	0	1	0	9
0	1	0	1	0	10
1	1	0	1	0	11
0	0	1	1	0	12
1	0	1	1	0	13
0	1	1	1	0	14
1	1	1	1	0	15
0	0	0	0	1	16
1	0	0	0	1	17
0	1	0	0	1	18
1	1	0	0	1	19
0	0	1	0	1	20
1	0	1	0	1	21
0	1	1	0	1	22
1	1	1	0	1	23
0	0	0	1	1	24
1	0	0	1	1	25
0	1	0	1	1	26
1	1	0	1	1	27
0	0	1	1	1	28
1	0	1	1	1	29
0	1	1	1	1	30
1	1	1	1	1	Not used

IMPORTANT

- The maximum number of slave stations depends on the method used for MECHATROLINK communication. Confirm the number of slave stations, and set the number of stations to a value that is equal to or less than the number of stations available.
- Do not duplicate a slave address within one communication circuit. Distributed I/O modules with duplicate slave addresses will not communicate correctly with each other or other devices.
- A new slave address set with pins 1 to 5 becomes effective as soon as the DIP switch is changed.

3.7.2 Performance Specifications

The performance specifications of 24-VDC 16-point Input Module are shown below.

When 12-VDC power is used, the Module does not comply with JIS B3501.

Item	Specifications	
	Operating Voltage	12 VDC
Name	24-VDC 16-point Input Module	
Model Description	V_DC24VIN-16P/IO2900	
Model Number	JAMSC-120DDI34300/JAMSC-IO2900-E	
Rated Voltage	12 or 24 VDC	
Maximum Allowable Voltage	30 VDC	
Input Format	Sinking or sourcing	
Rated Current	2.5 mA	5 mA
Input Impedance	4.8 k Ω	
Standard Operating Ranges	Minimum ON voltage: 9 VDC Maximum OFF voltage: 5 VDC	
Input Type	Not compliant with JIS B 3501 standards	DC type 2 (according to JIS B 3501)
Input Delay Times	OFF to ON: 5 ms max. ON to OFF: 5 ms max.	
Number of Commons	2	
Number of Inputs per Common	8 points/common	
External Connections	Removable terminal block with 23 M3 screw terminals	
Number of Inputs	16 points	
Input Signal Indication	One LED indicator for each input; lit when input is ON. Status saved in internal logic.	
Status Indication	External power supply normal: RUN indicator lit. Data being transmitted: TX indicator lit.	
Input Circuit Isolation	Isolation Method	Photocoupler
	Dielectric Strength	1,500 VAC for 1 minute between input terminals and internal circuits
	Insulation Resistance	100 M Ω min. at 500 VDC between input terminals and internal circuits (at room temperature and humidity)
External Power Supply	Input signal power supply: 12 VDC	Input signal power supply: 24 VDC
	Main external power supply: 24 VDC (20.4 to 26.4 VDC), 90 mA max. when all inputs are ON	
Derating Conditions	The maximum ambient operating temperature is limited with some mounting directions. Refer to 3.1.2 <i>Mounting Orientation</i> for details.	
Maximum Heating Value	2.16 W	
Hot Swapping	Terminal block: Not permitted Communication connector: Permitted	
Mass	Approx. 300 g	
Dimensions (mm)	152 × 44 × 71.8 (W × H × D)	

3.7.3 Circuit Configuration

The following illustration shows the circuit configuration for the 24-VDC 16-point Input Module.

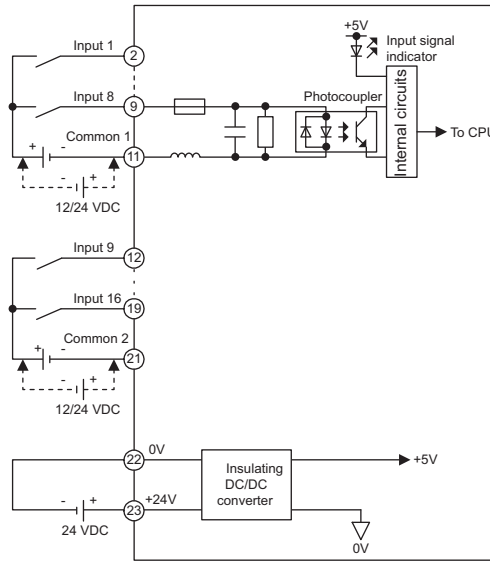

3.7.4 Connection Example

The following illustration shows an example of terminal connections for the 24-VDC 16-point Input Module.

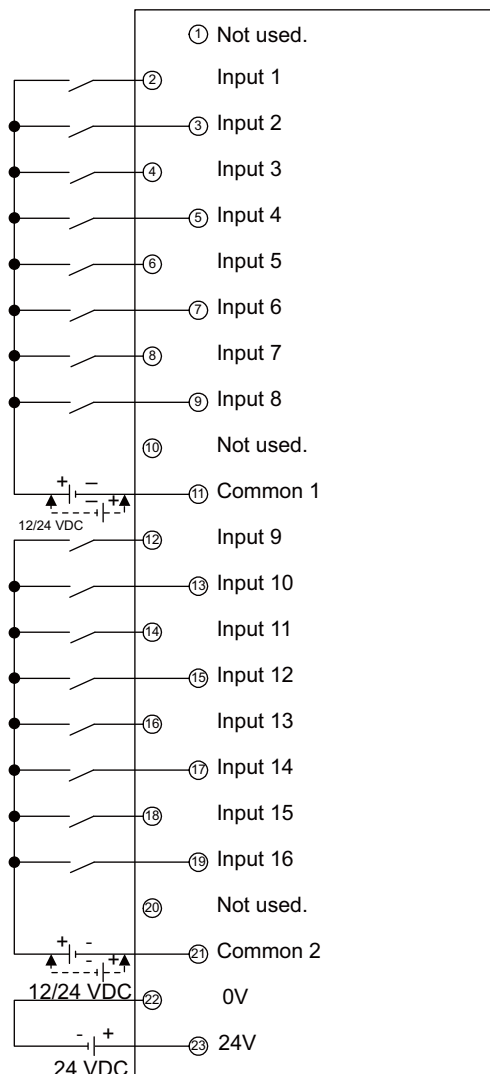

Note: 1. Terminals 10 and 20 are not used.
 2. Do not connect anything to terminal 1.

IMPORTANT

- Use crimp terminals that fit M3 screws for terminal block wiring.
- Use wire with the following guage when connecting wire to the terminal block.
24 AWG (0.2 mm²) to 18 AWG (0.9 mm²)
- The polarity of the external signal power supply can be connected in either direction.

3.7.5 I/O Allocations

The leading register number of the I/O registers used by the 24-VDC 16-point Input Module is set in the I/O Assignment Tab in the MECHATROLINK definitions window.

Refer to *Chapter 2 I/O Allocations* for details on allocating I/O to MECHATROLINK Modules.

The following example shows how 16 input relays are allocated from IW0010.

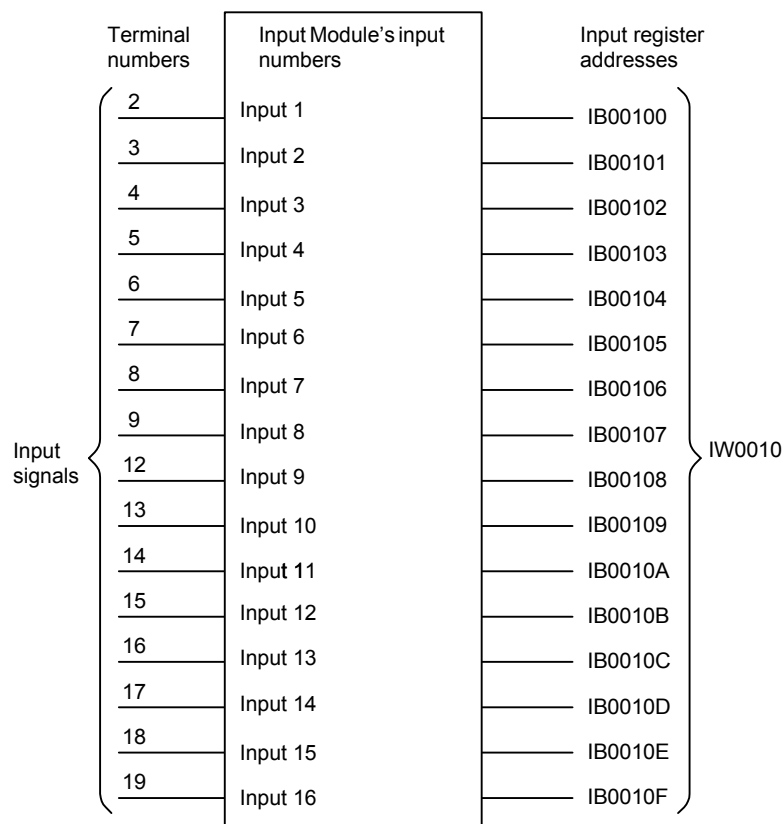

3.8 24-VDC 16-point Output Module (120DDO34340/IO2910)

3.8.1 External Appearance and Configuration

The following diagram shows the 24-VDC 16-point Output Module's external parts.

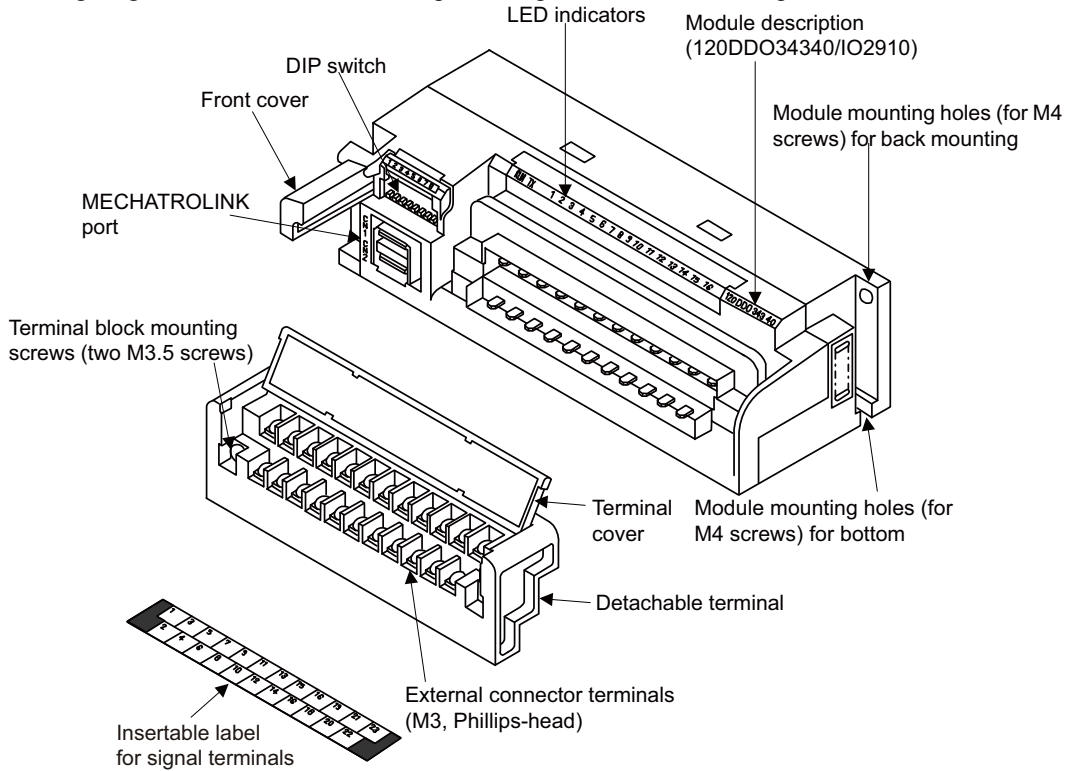

(1) LED Indicators

RUN TX ERR 1 2 3 4 5 6 7 8 9 10 11 12 13 14 15 16																
Indicator Name	Indicator Color	Meaning When Lit														
RUN	Green	The external power is being supplied normally.														
TX	Green	Sending data.														
ERR	Red	Blown fuse or disconnected load power supply														
1 to 16	Green	The corresponding indicator is lit when that input signal is ON.														

(2) DIP Switch

Before using the 24 VDC 16-point Output Module, the settings for the DIP switch on the front of the Module must be made.

(a) DIP Switch Functions

The DIP switch consists of eight pins. The pins are numbered 1 to 8, as shown in the following diagram. Each pin is turned to ON when it is moved to the upper position.

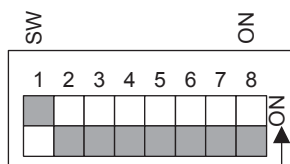

The setting of each pin becomes effective as soon as the DIP switch is changed.

The following table shows the functions that correspond to the settings for each pin.

• 120DDO34340

Pin No.	Setting	Function	Factory Setting
1 to 5	ON	Set the slave address of pins 1 through 5. For details, refer to (b) <i>Slave Address Settings</i> .	1: ON 2 to 5: OFF
	OFF		
6	ON	Set the baud rate to 1 Mbps.	OFF
	OFF	Set the baud rate to 4 Mbps.	
7	ON	With a Digital Output Module, the user can select the status of output data when communication is stopped. This setting retains the status of the outputs that existed before communication stopped.	OFF
	OFF	With a Digital Output Module, the user can select the status of output data when communication is stopped. This setting turns OFF all outputs when communication stops.	OFF
8	ON	Reserved for future use. Leave pin 8 in the OFF position.	OFF
	OFF		

• IO2910

Pin No.	Setting	Function	Factory Setting
1 to 5	ON	Set the slave address of pins 1 through 5. For details, refer to (b) <i>Slave Address Settings</i> .	1: ON 2 to 5: OFF
	OFF		
6	ON	Set the communication data length to 32 bytes.	OFF
	OFF	Set the communication data length to 17 bytes.	
7	ON	With a Digital Output Module, the user can select the status of output data when communication is stopped. This setting retains the status of the outputs that existed before communication stopped.	OFF
	OFF	With a Digital Output Module, the user can select the status of output data when communication is stopped. This setting turns OFF all outputs when communication stops.	OFF
8	ON	Set the baud rate to 10 Mbps.	OFF
	OFF	Set the baud rate to 4 Mbps.	

(b) Slave Address Settings

Set the slave address with pins 1 to 5 on the DIP switch on the front of the Distributed I/O Module. Refer to the following table, and set the slave addresses as required.

Pin No.					Slave Address
1	2	3	4	5	
0	0	0	0	0	Not used
1	0	0	0	0	1
0	1	0	0	0	2
1	1	0	0	0	3
0	0	1	0	0	4
1	0	1	0	0	5
0	1	1	0	0	6
1	1	1	0	0	7
0	0	0	1	0	8
1	0	0	1	0	9
0	1	0	1	0	10
1	1	0	1	0	11
0	0	1	1	0	12
1	0	1	1	0	13
0	1	1	1	0	14
1	1	1	1	0	15
0	0	0	0	1	16
1	0	0	0	1	17
0	1	0	0	1	18
1	1	0	0	1	19
0	0	1	0	1	20
1	0	1	0	1	21
0	1	1	0	1	22
1	1	1	0	1	23
0	0	0	1	1	24
1	0	0	1	1	25
0	1	0	1	1	26
1	1	0	1	1	27
0	0	1	1	1	28
1	0	1	1	1	29
0	1	1	1	1	30
1	1	1	1	1	Not used

IMPORTANT

- The maximum number of slave stations depends on the method used for MECHATROLINK communication. Confirm the number of slave stations, and set the number of stations to a value that is equal to or less than the number of stations available.
- Do not duplicate a slave address within one communication circuit. Distributed I/O modules with duplicate slave addresses will not communicate correctly with each other or other devices.
- A new slave address set with pins 1 to 5 becomes effective as soon as the DIP switch is changed.

3.8.2 Performance Specifications

The performance specifications of 24-VDC 16-point Output Module are shown below.

Item	Specifications	
Name	24-VDC 16-point Output Module (Sinking)	
Model Description	V_DC24OUT-16P/IO2910	
Model Number	JAMSC-120DDO34340/JAMSC-IO2910-E	
Rated Voltage	12/24 VDC	
Allowable Voltage Range	10.2 to 30.0 VDC	
Output Format	Sinking	
Maximum Load Current	0.3 A/output	
Output Voltage Drop	1.5 V max. (0.3 A)	
Output Delay Times	OFF to ON: 1 ms max. ON to OFF: 1 ms max.	
Leakage Current when OFF	1 mA max. at 24 VDC	
Output Type	Transistor outputs	
Number of Commons	2	
Number of Outputs per Common	8 points/common	
External Connections	Removable terminal block with 23 M3 screw terminals	
Output Protection Type	Unprotected outputs (according to JIS B 3501)	
Built-in Fuse	Two 3.5-A fuses (1 fuse/common) (Opening time: 5 seconds max. at 200% of rated current)	
Surge Suppression	None	
Other Output Protection	None	
Number of Outputs	16 points	
Output Signal Indication	One LED indicator for each output; lit when output is ON. Status saved in internal logic.	
Status Indication	External power supply normal: RUN indicator lit. Data being transmitted: TX indicator lit. Blown fuse or load power supply disconnected: ERR indicator lit.	
Output Circuit Isolation	Isolation Method	Photocoupler
	Dielectric Strength	1,500 VAC for 1 minute between output terminals and internal circuits.
	Insulation Resistance	100 MΩ min. at 500 VDC between input terminals and internal circuits (at room temperature and humidity)
External Power Supply	12/24 VDC supplied to drive loads Main external power supply: 24 VDC (20.4 to 26.4 VDC), 110 mA when all outputs are ON	
Derating Conditions	The maximum ambient operating temperature is limited with some mounting directions. Refer to <i>3.1.2 Mounting Orientation</i> for details.	
Maximum Heating Value	2.64 W	
Hot Swapping	Terminal block: Not permitted Communication connector: Permitted	
Mass	Approx. 300 g	
Dimensions (mm)	152 × 44 × 71.8 (W × H × D)	

3.8.3 Circuit Configuration

 CAUTION

- Built-in fuse do not protect the output elements. Connect a fuse appropriate for the load specifications in series with the load.
 There is a risk of fire, damage to the load equipment, or damage to the output circuits if there is a load short-circuit or overload.

The following illustration shows the circuit configuration for the 24-VDC 16-point Output Module.

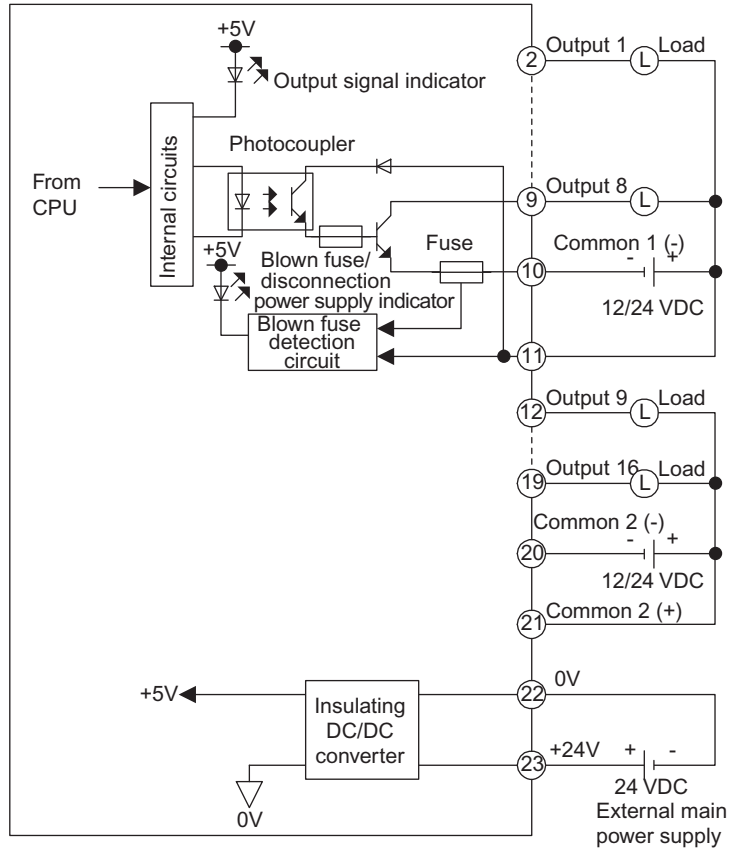

IMPORTANT

Communication with the master will stop when the load power supply is OFF or the fuse blows.

3.8.4 Connection Example



CAUTION

- Built-in fuse do not protect the output elements. Connect a fuse appropriate for the load specifications in series with the load.

There is a risk of fire, damage to the load equipment, or damage to the output circuits if there is a load short-circuit or overload.

The following illustration shows an example of terminal connections for the 24-VDC 16-point Output Module.

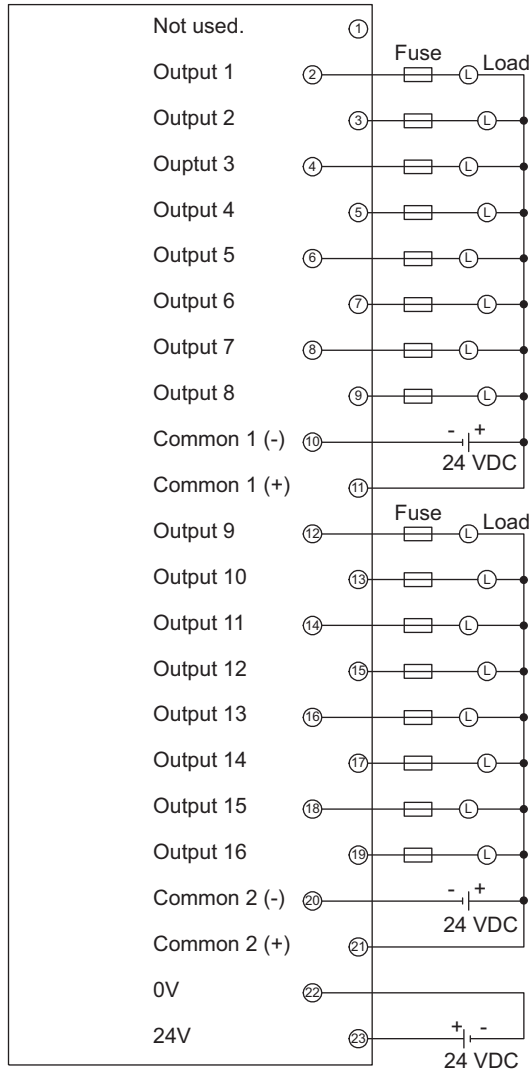

Note: Do not connect anything to terminal 1.

IMPORTANT

- Use crimp terminals that fit M3 screws for terminal block wiring.
- Use wire with the following gauge when connecting wire to the terminal block.
24 AWG (0.2 mm²) to 18 AWG (0.9 mm²)

3.8.5 I/O Allocations

The leading register number of the I/O registers used by the 24-VDC 16-point Output Module is set in the I/O Assignment Tab in the MECHATROLINK definitions window.

Refer to *Chapter 2 I/O Allocations* for details on allocating I/O to MECHATROLINK Modules.

The following example shows how 16 output coils are allocated from OW0010.

Output register address	Output Module's output numbers	Terminal numbers
OB00100	Output 1	2
OB00101	Output 2	3
OB00102	Output 3	4
OB00103	Output 4	5
OB00104	Output 5	6
OB00105	Output 6	7
OB00106	Output 7	8
OB00107	Output 8	9
OB00108	Output 9	12
OB00109	Output 10	13
OB0010A	Output 11	14
OB0010B	Output 12	15
OB0010C	Output 13	16
OB0010D	Output 14	17
OB0010E	Output 15	18
OB0010F	Output 16	19

OW0010 {

} Output signals

3.9 Analog Input Module (± 10 V, 4 CH) (120AVI02030/AN2900)

3.9.1 External Appearance and Configuration

The following diagram shows the Analog Input Module's external parts.

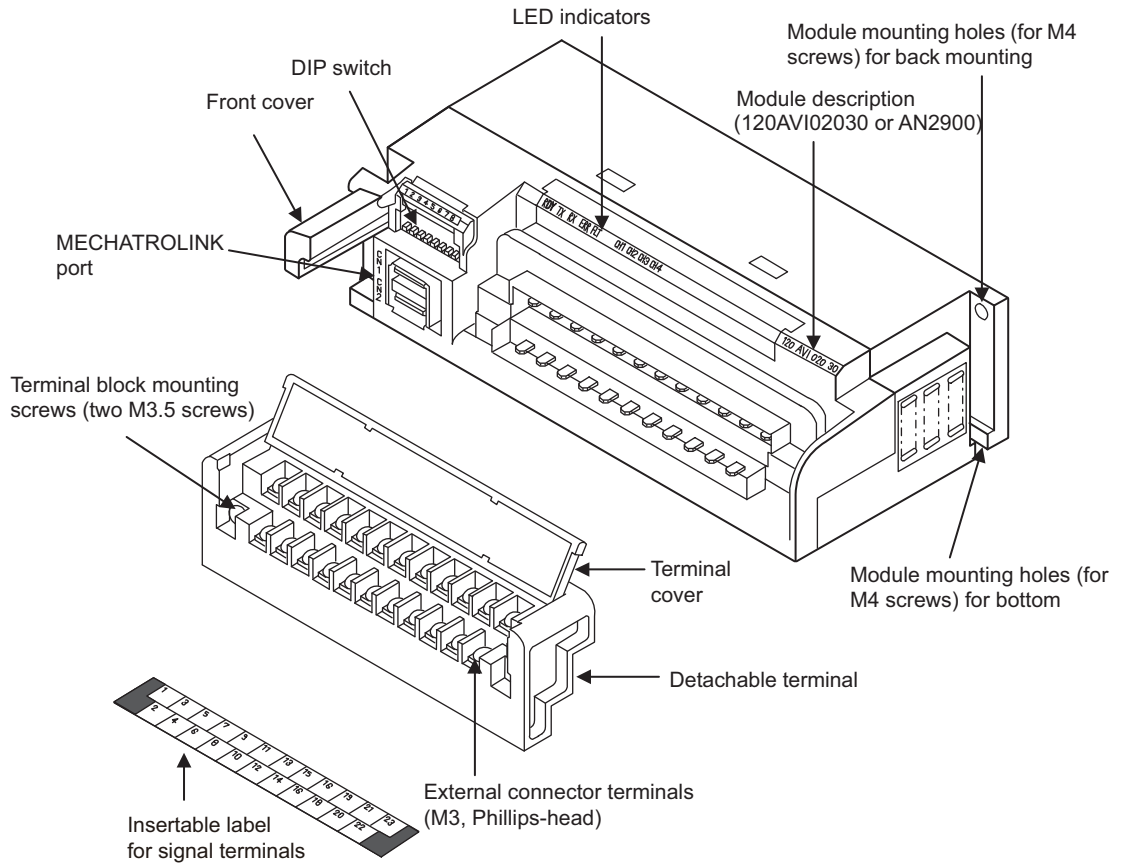

(1) LED Indicators

Indicator Name	Indicator Color	Meaning When Lit or Flashing	
RDY	Green	Lit	The Module is operating normally.
		Flashing	The transmission cable is disconnected or the Module is waiting for communication with the master.
TX	Green	Lit	Sending data.
RX	Green	Lit	Receiving data.
ERR	Red	Lit	A communication error occurred.
FLT	Red	Lit	Offset/gain setting error
		Flashing	Self-diagnostic error
CH1 to CH4	Green	Lit	Each LED indicates that the input is out-of-range for that channel. Out-of-range inputs are as follows: $+10.02 \text{ V} < \text{Channel input signal}$ $\text{Channel input signal} < -10.02 \text{ V}$

(2) DIP Switch

Before using the Analog Input Module, the settings for the DIP switch on the front of the Module must be made.

(a) DIP Switch Functions

The DIP switch consists of eight pins. The pins are numbered 1 to 8, as shown in the following diagram. Each pin is turned to ON when it is moved to the upper position.

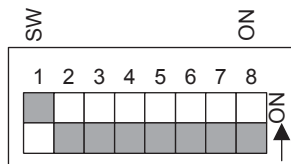

The following shows the function of each switch.

Any switches other than pin 7 becomes effective when each switch is changed.

- 120AVI02030

Pin No.	Setting	Function	Factory Setting
1 to 5	ON	Set the slave address of pins 1 through 5. For details, refer to (b) <i>Slave Address Settings</i> .	1: ON 2 to 5: OFF
	OFF		
6	ON	Set the baud rate to 1 Mbps.	OFF
	OFF	Set the baud rate to 4 Mbps.	
7	ON	Software filter (average 5 times) is set to "enabled."	OFF
	OFF	Software filter is set to "disabled."	
8	ON	Reserved for future use. Leave pin 8 in the OFF position.	OFF
	OFF		

- AN2900

Pin No.	Setting	Function	Factory Setting
1 to 5	ON	Set the slave address of pins 1 through 5. For details, refer to (b) <i>Slave Address Settings</i> .	1: ON 2 to 5: OFF
	OFF		
6	ON	If SW8 turns ON, set the communication data length to 32 bytes. If SW8 turns OFF, set SW6 to OFF.	OFF
	OFF	When SW8 turns ON, set the communication data length to 17 bytes. When SW8 turns OFF, set SW6 to OFF.	
7	ON	Software filter (average 5 times) is set to "Enabled."	OFF
	OFF	Software filter is set to "Disabled."	
8	ON	Set the baud rate to 10 Mbps.	ON
	OFF	Set the baud rate to 4 Mbps.	

IMPORTANT

- If the external power supply (24 VDC) is turned ON, pin 7 becomes effective. To change the setting, turn the external power supply (24 VDC) OFF and then ON again.
- The software filter sends the value obtained by averaging three input signals out of five input signals read by the Analog Input module, excluding the maximum and minimum values.
- The AN2900 does not operate at 1-Mbps baud rate.

(b) Slave Address Settings

Set the slave address with pins 1 to 5 on the DIP switch on the front of the Distributed I/O Module. Refer to the following table, and set the slave addresses as required.

Pin No.					Slave Address
1	2	3	4	5	
0	0	0	0	0	Not used
1	0	0	0	0	1
0	1	0	0	0	2
1	1	0	0	0	3
0	0	1	0	0	4
1	0	1	0	0	5
0	1	1	0	0	6
1	1	1	0	0	7
0	0	0	1	0	8
1	0	0	1	0	9
0	1	0	1	0	10
1	1	0	1	0	11
0	0	1	1	0	12
1	0	1	1	0	13
0	1	1	1	0	14
1	1	1	1	0	15
0	0	0	0	1	16
1	0	0	0	1	17
0	1	0	0	1	18
1	1	0	0	1	19
0	0	1	0	1	20
1	0	1	0	1	21
0	1	1	0	1	22
1	1	1	0	1	23
0	0	0	1	1	24
1	0	0	1	1	25
0	1	0	1	1	26
1	1	0	1	1	27
0	0	1	1	1	28
1	0	1	1	1	29
0	1	1	1	1	30
1	1	1	1	1	Not used

IMPORTANT

- The maximum number of slave stations depends on the method used for MECHATROLINK communication. Confirm the number of slave stations, and set the number of stations to a value that is equal to or less than the number of stations available.
- Do not duplicate a slave address within one communication circuit. Distributed I/O modules with duplicate slave addresses will not communicate correctly with each other or other devices.
- A new slave address set with pins 1 to 5 becomes effective as soon as the DIP switch is changed.

3.9.2 Performance Specifications

The performance specifications of Analog Input Module (± 10 V, 4 CH) are shown below.

Item	Specifications																								
Name	Analog Input Module (± 10 V, 4 CH)																								
Model Description	V_AD-VOL-4CH/AN2900																								
Model Number	JAMSC-120AVI02030/JEPMC-AN2900																								
Input Signal Range	-10 to 10V																								
Special Inputs	None																								
Number of Input Channels	4 channels, isolated as a group																								
Input Impedance	1 M Ω min.																								
Maximum Allowable Overload	-20 to 20 V																								
Digital Resolution	16 bits																								
Data Format	Binary (2s complement) -32,000 to 32,000																								
Error	$\pm 0.5\%$ F.S. (at 25°C) $\pm 1.0\%$ F.S. (at 0 to 60°C)																								
Input Delay Time	4 ms max.																								
Sampling Interval	Input data is refreshed every communication cycle.																								
Input Filter Characteristics	Software filter																								
Number of Allocated Words	5 words/Module																								
Maintenance/Diagnostic Functions	Watchdog timer																								
External Connections	Removable terminal block with 23 M3 screw terminals																								
Status Indication	<table border="0"> <tr> <td>RDY (green)</td> <td>Lit</td> <td>Normal Module status</td> </tr> <tr> <td></td> <td>Flashing</td> <td>Transmission cable disconnected or waiting for communication from the master</td> </tr> <tr> <td>TX (green)</td> <td>Lit</td> <td>Sending data.</td> </tr> <tr> <td>RX (green)</td> <td>Lit</td> <td>Receiving data.</td> </tr> <tr> <td>ERR (red)</td> <td>Lit</td> <td>Communication error</td> </tr> <tr> <td>FLT (red)</td> <td>Lit</td> <td>Error in offset/gain settings</td> </tr> <tr> <td></td> <td>Flashing</td> <td>Error detected in self-diagnostics</td> </tr> <tr> <td>CH1 to CH4</td> <td>Lit</td> <td>The input at the corresponding channel is out-of-range. (An input is out-of-range when it is below -10.02 V or above +10.02 V.)</td> </tr> </table>	RDY (green)	Lit	Normal Module status		Flashing	Transmission cable disconnected or waiting for communication from the master	TX (green)	Lit	Sending data.	RX (green)	Lit	Receiving data.	ERR (red)	Lit	Communication error	FLT (red)	Lit	Error in offset/gain settings		Flashing	Error detected in self-diagnostics	CH1 to CH4	Lit	The input at the corresponding channel is out-of-range. (An input is out-of-range when it is below -10.02 V or above +10.02 V.)
RDY (green)	Lit	Normal Module status																							
	Flashing	Transmission cable disconnected or waiting for communication from the master																							
TX (green)	Lit	Sending data.																							
RX (green)	Lit	Receiving data.																							
ERR (red)	Lit	Communication error																							
FLT (red)	Lit	Error in offset/gain settings																							
	Flashing	Error detected in self-diagnostics																							
CH1 to CH4	Lit	The input at the corresponding channel is out-of-range. (An input is out-of-range when it is below -10.02 V or above +10.02 V.)																							
Input Circuit Isolation	Isolation Method	Photocoupler (There is no isolation between input channels.)																							
	Dielectric Strength	1,500 VAC for 1 minute between input terminals and internal circuits																							
	Insulation Resistance	100 M Ω min. at 500 VDC between input terminals and internal circuits (at room temperature and humidity)																							
External Power Supply	Main external power supply: 24 VDC (20.4 to 26.4 VDC), 150 mA max.																								
Derating Conditions	The maximum ambient operating temperature is limited with some mounting directions. Refer to 3.1.2 <i>Mounting Orientation</i> for details.																								
Maximum Heating Value	3.6 W																								
Hot Swapping	Terminal block: Not permitted Communication connector: Permitted																								
Mass	Approx. 300 g																								
Dimensions (mm)	161 × 44 × 79 (W × H × D)																								

3.9.3 Input Characteristics

The following table shows the Module's input characteristics for the Analog Input Module.

Input Voltage (V)	Input Register Value (Decimal)
≤ -10.00	-32,000
-10.00	-32,000
-5.00	-16,000
0.00	0
5.00	16,000
10.00	32,000
≥ 10.00	32,000

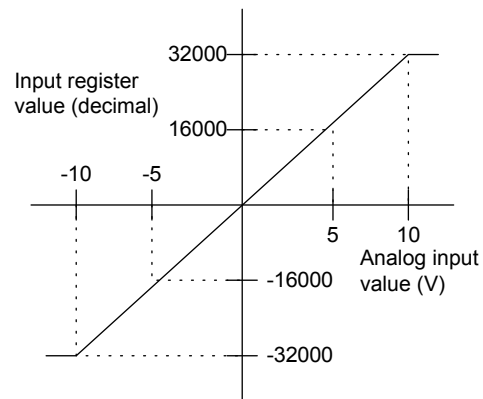

If the input value is below -10.00 V, the value in the input register will remain at -32,000. If the input value is above 10.00 V, the value in the input register will remain at 32,000.

3.9.4 Circuit Configuration

The following illustration shows the circuit configuration for the Analog Input Module.

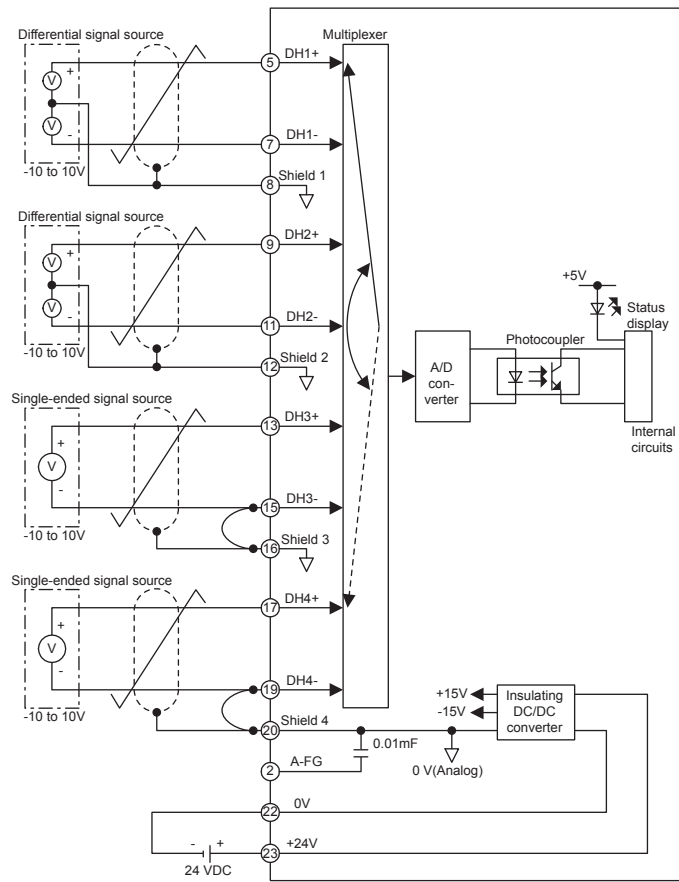

3.9.5 Connection Example

The following illustration shows an example of terminal connections for the Analog Input Module.

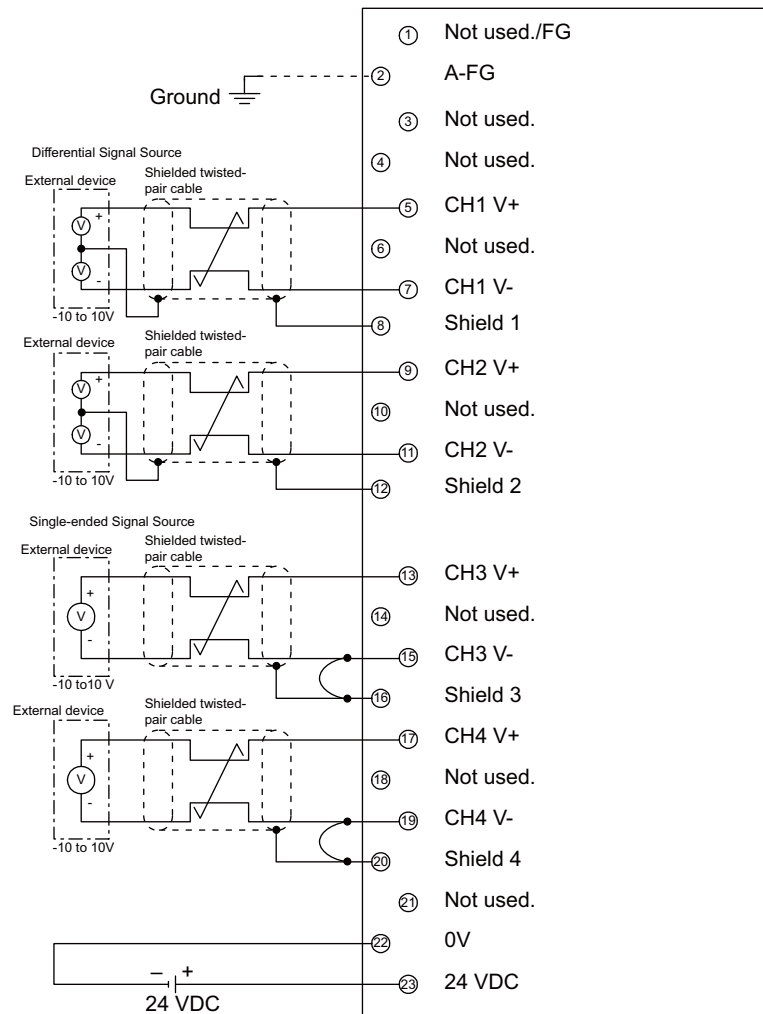

Note: 1. Terminals 3, 4, 6, 10, 14, 18, and 21 are not used.

2. Use terminal 1 as follows:

For 120AVI02030: Do not connect.

For AN2900: Be sure to ground since it is an FG terminal.

IMPORTANT

- **Isolation between Input Channels**

There is no isolation provided between the input circuit channels.
If isolation between channels is required, use a commercial isolation amplifier for each channel.
 - **Recommended Wire**

Use shielded two-conductor twisted-pair cable with 20 AWG (0.5 mm²) to 16 AWG (1.25 mm²) wire to connect to the terminal block.
 - **Connecting Differential Signal Sources**
 - Connect the positive side of a differential signal to the Module's "+" terminal.
 - Connect the negative side of a differential signal to the Module's "-" terminal.
 - At the Module end, connect the shield of the cable to the shield terminal of the Module.
 - At the signal source end, connect the shield of the cable to the 0 V of the differential signal source. An improper connection will make the input signal unstable and cause malfunction.
 - **Connecting Single-ended Signal Sources**
 - Connect the positive side of the single-ended signal to the Module's "+" terminal.
 - Connect the negative side of the single-ended signal to the Module's "-" terminal.
 - Connect the shield of the cable to the shield terminal of the Module and short the shield terminal to the "-" terminal.
An improper connection will make input signal unstable and cause malfunction.
 - **Unused Input Circuits**

For an unused input circuit, short its "+" terminal to its "-" terminal and also short one of these terminals to its shield terminal.
An improper connection will make input signal unstable and cause malfunction.
 - **A-FG Terminal**

Depending upon the ambient noise, better performance may be possible by grounding the A-FG terminal.
 - **Crimp Terminals**

Use crimp terminals that fit M3 screws for terminal block wiring.
-

3.9.6 I/O Allocations

The leading register numbers of the I/O registers used by the Analog Input Module are set in the I/O Assignment Tab in the MECHATROLINK definitions window.

Refer to *Chapter 2 I/O Allocations* for details on allocating I/O to MECHATROLINK Modules.

The following example shows the allocation of the 7 words of input registers and 2 words of output registers used by the Analog Input Module.

(1) Output Registers (2 words)

Output Register No.	Contents
OWxxxx	Reserved for the system
OWxxxx+1	Not used.

IMPORTANT

Registers reserved for the system must not be overwritten from the ladder program or other means. The Module will not operate normally if registers are overwritten.

(2) Input Registers (7 words)

Input Register No.	Contents
IWxxxx	Reserved for the system
IWxxxx+1	Reserved for the system
IWxxxx+2	Analog input value of CH1 (-32,000 to 32,000)
IWxxxx+3	Analog input value of CH2 (-32,000 to 32,000)
IWxxxx+4	Analog input value of CH3 (-32,000 to 32,000)
IWxxxx+5	Analog input value of CH4 (-32,000 to 32,000)
IWxxxx+6	Input signal status

(3) Input Signal Status

The Analog Input Module produces an error signal when an input signal is outside of the input signal range.

Input Register No.	Bit	Contents
IWxxxx+6	0	ON (1) when the CH1 input signal is below -10.02 V or above 10.02 V.
	1	ON (1) when the CH2 input signal is below -10.02 V or above 10.02 V.
	2	ON (1) when the CH3 input signal is below -10.02 V or above 10.02 V.
	3	ON (1) when the CH4 input signal is below -10.02 V or above 10.02 V.
	4 to F	Not used.

3.10 Analog Output Module (± 10 V, 2 CH) (120AVO01030/AN2910)

3.10.1 External Appearance and Configuration

The following diagram shows the Analog Output Module's external parts.

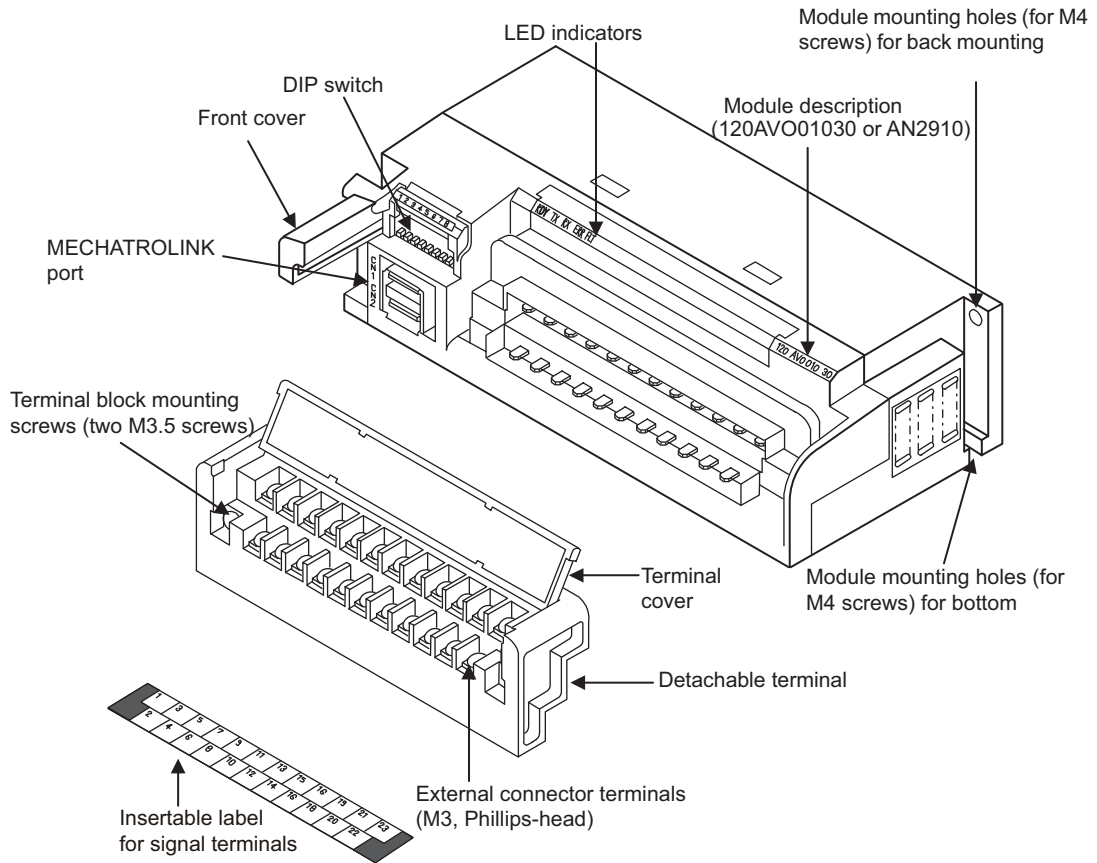

(1) LED Indicators

RDY	TX	RX	ERR	FLT
-----	----	----	-----	-----

Indicator Name	Indicator Color	Meaning When Lit or Flashing	
RDY	Green	Lit	The Module is operating normally.
		Flashing	The transmission cable is disconnected or the Module is waiting for communication with the master.
TX	Green	Lit	Sending data.
RX	Green	Lit	Receiving data.
ERR	Red	Lit	A communication error occurred.
FLT	Red	Lit	Offset/gain setting error
		Flashing	Self-diagnostic error

(2) DIP Switch

Before using the Analog Output Module, the settings for the DIP switch on the front of the Module must be made.

(a) DIP Switch Functions

The DIP switch consists of eight pins. The pins are numbered 1 to 8, as shown in the following diagram. Each pin is turned to ON when it is moved to the upper position.

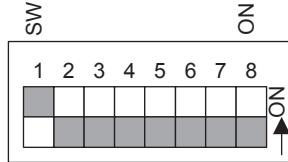

The setting of each pin becomes effective as soon as the DIP switch is changed.

The following table shows the functions that correspond to the settings for each pin.

• 120AVO01030

Pin No.	Setting	Function	Factory Setting
1 to 5	ON	Set the slave address of pins 1 through 5. For details, refer to (b) <i>Slave Address Settings</i> .	1: ON 2 to 5: OFF
	OFF		
6	ON	Set the baud rate to 1 Mbps.	OFF
	OFF	Set the baud rate to 4 Mbps.	
7	ON	The output when communication stops is set to “data immediately before stop.”	OFF
	OFF	The output when communication stops is set to “0.”	
8	ON	Reserved for future use. Leave pin 8 in the OFF position.	OFF
	OFF		

• AN2910

Pin No.	Setting	Function	Factory Setting
1 to 5	ON	Set the slave address of pins 1 through 5. For details, refer to (b) <i>Slave Address Settings</i> .	1: ON 2 to 5: OFF
	OFF		
6	ON	When SW8 turns ON, set the communication data length to 32 bytes. When SW8 turns OFF, set SW6 to OFF.	OFF
	OFF	When SW8 turns ON, set the communication data length to 17 bytes. When SW8 turns OFF, set SW6 to OFF.	
7	ON	The output when communication stops is set to “data immediately before stop.”	OFF
	OFF	The output when communication stops is set to “0.”	
8	ON	Set the baud rate to 10 Mbps.	ON
	OFF	Set the baud rate to 4 Mbps.	

IMPORTANT

- AN2910 do not operate at 1-Mbps baud rate.
- If AN2910 is used at 10 Mbps, set the MECHATROLINK communications cycle to 1 ms or more. For details on the settings of the MECHATROLINK communications cycle, refer to 2.2.2 *Setting Transmission Parameters*.

(b) Slave Address Settings

Set the slave address with pins 1 to 5 on the DIP switch on the front of the Distributed I/O Module. Refer to the following table, and set the slave addresses as required.

Pin No.					Slave Address
1	2	3	4	5	
0	0	0	0	0	Not used
1	0	0	0	0	1
0	1	0	0	0	2
1	1	0	0	0	3
0	0	1	0	0	4
1	0	1	0	0	5
0	1	1	0	0	6
1	1	1	0	0	7
0	0	0	1	0	8
1	0	0	1	0	9
0	1	0	1	0	10
1	1	0	1	0	11
0	0	1	1	0	12
1	0	1	1	0	13
0	1	1	1	0	14
1	1	1	1	0	15
0	0	0	0	1	16
1	0	0	0	1	17
0	1	0	0	1	18
1	1	0	0	1	19
0	0	1	0	1	20
1	0	1	0	1	21
0	1	1	0	1	22
1	1	1	0	1	23
0	0	0	1	1	24
1	0	0	1	1	25
0	1	0	1	1	26
1	1	0	1	1	27
0	0	1	1	1	28
1	0	1	1	1	29
0	1	1	1	1	30
1	1	1	1	1	Not used

IMPORTANT

- The maximum number of slave stations depends on the method used for MECHATROLINK communication. Confirm the number of slave stations, and set the number of stations to a value that is equal to or less than the number of stations available.
- Do not duplicate a slave address within one communication circuit. Distributed I/O modules with duplicate slave addresses will not communicate correctly with each other or other devices.
- A new slave address set with pins 1 to 5 becomes effective as soon as the DIP switch is changed.

3.10.2 Performance Specifications

The performance specifications of Analog Output Module (± 10 V, 2 CH) are shown below.

Item		Specifications
Name		Analog Output Module (± 10 V, 2 CH)
Model Description		V_DA-VOL-2CH/AN2910
Model Number		JAMSC-120AVO01030/JEPMC-AN2910
Input Signal Range		-10 to 10V
Number of Output Channels		2 channels
Maximum Allowable Load Current		± 5 mA (2 k Ω)
Digital Resolution		16 bits
Data Format		Binary (2s complement) -32,000 to 32,000
Error		$\pm 0.2\%$ F.S. (at 25°C) $\pm 0.5\%$ F.S. (at 0 to 60°C)
Output Delay Time		1 ms
Number of Allocated Words		2 words/Module
Maintenance/Diagnostic Functions		Watchdog timer
Output Status when Master Stops		Mode selected with the DIP switch (SW7): SW7 OFF: Clear outputs. (Output 0 V) SW7 ON: Retain prior output status.
External Connections		Removable terminal block with M3 screw terminals
Status Indication		RDY (green) Lit Normal Module status Flashing Transmission cable disconnected or waiting for communication from the master TX (green) Lit Sending data. RX (green) Lit Receiving data. ERR (red) Lit Communication error FLT (red) Lit Error in offset/gain settings Flashing Error detected in self-diagnostics
Output Circuit Isolation	Isolation Method	Photocoupler (There is no isolation between channels.)
	Dielectric Strength	1,500 VAC for 1 minute between output terminals and internal circuits
	Insulation Resistance	100 M Ω min. at 500 VDC between input terminals and internal circuits (at room temperature and humidity)
External Power Supply		Main external power supply: 24 VDC (20.4 to 26.4 VDC), 180 mA max.
Derating Conditions		The maximum ambient operating temperature is limited with some mounting directions. Refer to <i>3.1.2 Mounting Orientation</i> for details.
Maximum Heating Value		4.32 W
Hot Swapping		Terminal block: Not permitted Communication connector: Permitted
Mass		Approx. 300 g
Dimensions (mm)		161 \times 44 \times 79 (W \times H \times D)

3.10.3 Output Characteristics

The following table shows the output characteristics for the Analog Output Module.

Output register value (decimal)	Output voltage (V)
$\leq -32,000$	-10.00
-32,000	-10.00
-16,000	-5.00
0	0.00
16,000	5.00
32,000	10.00
$\geq 32,000$	10.00

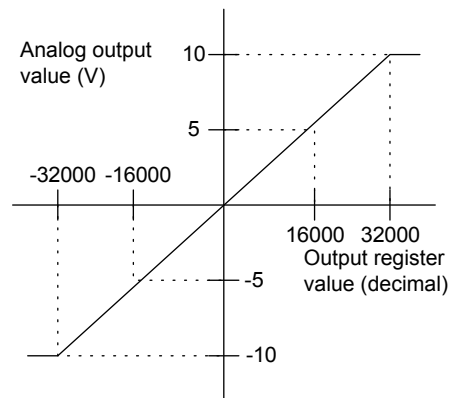

The analog output value will remain at -10.00 V even if the output register value falls below -32,000. The analog output value will remain at 10.00 V even if the output register value rises above 32,000.

3.10.4 Circuit Configuration

The following illustration shows the circuit configuration for the Analog Output Module.

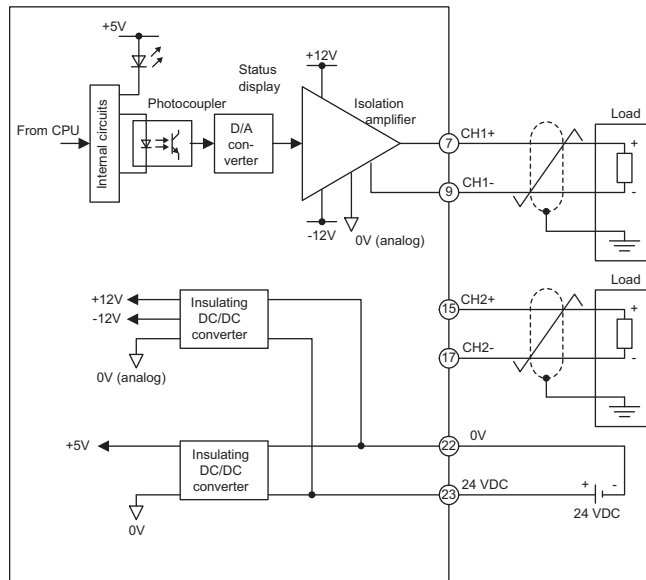

3.10.5 Connection Example

The following illustration shows an example of terminal connections for the Analog Output Module.

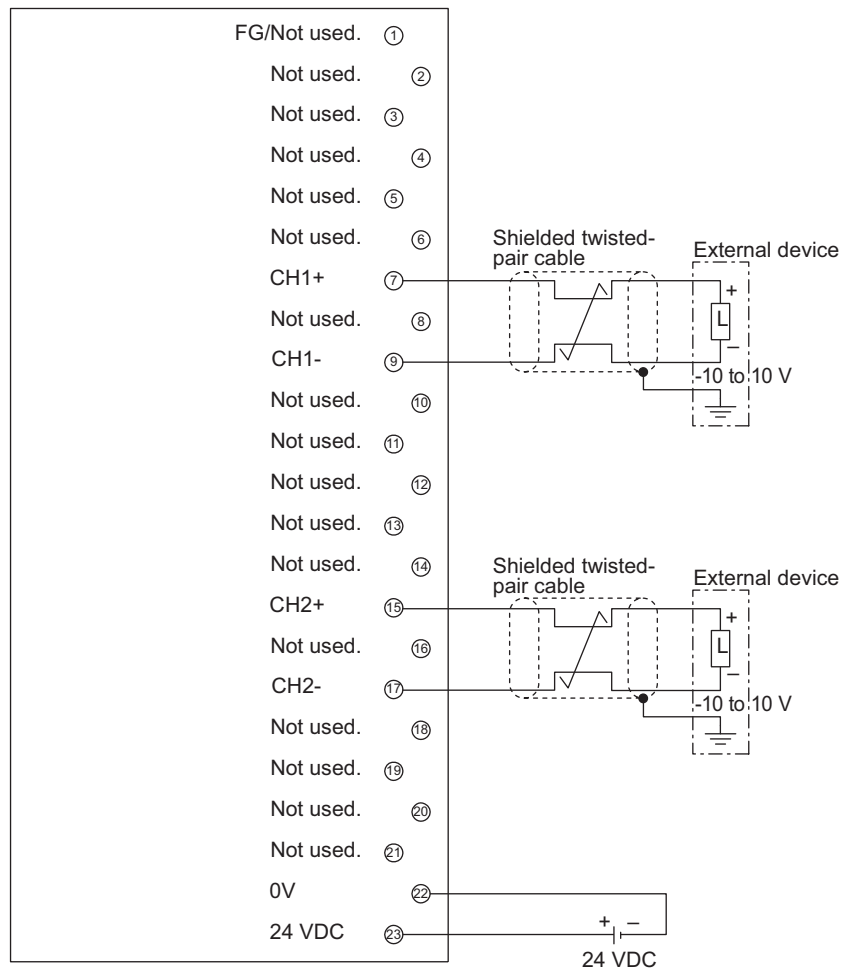

- Note: 1. Terminals 2 to 6, 8, 10 to 14, 16, and 18 to 21 are not used.
 2. Use terminal 1 as follows:
 For 120AVO01030: Do not connect.
 For AN2910: Be sure to ground since it is an FG terminal.

IMPORTANT

- The output circuit's output channels are not isolated from each other.
- Recommended Wire

Use shielded two-conductor twisted-pair cable with 20 AWG (0.5 mm²) to 16 AWG (1.25 mm²) wire to connect to the terminal block.

- Ground the Shield at One Point.

As a rule, connect the shield at one point on the load end. However, better output characteristics may be obtained by grounding the shield on the Module end rather than on the load end, so test which configuration is better for the actual situation. An improper connection will make output signal unstable and cause malfunction.

- Grounding at the Module.

The Module's unused terminals are not connected to anything within the Module, so they can be used as relay terminals.

- Crimp Terminals

Use crimp terminals that fit M3 screws for terminal block wiring.

3.10.6 I/O Allocations

The leading register numbers of the I/O registers used by the Analog Output Module are set in the I/O Assignment Tab in the MECHATROLINK definitions window.

Refer to *Chapter 2 I/O Allocations* for details on allocating I/O to MECHATROLINK Modules.

The following example shows the allocation of the 4 words of output registers and 2 words of input registers used by the Analog Output Module.

(1) Output Registers (4 words)

Output Register No.	Contents
OWxxxx	Reserved for the system
OWxxxx+1	Reserved for the system
OWxxxx+2	Analog output value of CH1
OWxxxx+3	Analog output value of CH2

IMPORTANT

- The analog output value will remain at -10.00 V even if the output register value falls below -32,000. The analog output value will remain at 10.00 V even if the output register value rises above 32,000.
- Registers reserved for the system must not be overwritten from the ladder program or other means. The Module will not operate normally if registers are overwritten.

(2) Input Registers (2 words)

Input Register No.	Contents
IWxxxx	Reserved for the system
IWxxxx+1	Reserved for the system

Other I/O Modules

This section provides an overview of other Digital I/O Modules.

4.1 64-point I/O Module (JEPMC-IO350/IO2310/IO2330) -----	4-2
4.1.1 External Appearance and Configuration -----	4-2
4.1.2 Performance Specifications -----	4-6
4.1.3 System Connection -----	4-9
4.2 Wildcard I/O Modules (□□□□□I/O) -----	4-19

4.1 64-point I/O Module (JEPMC-IO350/IO2310/IO2330)

4.1.1 External Appearance and Configuration

The following diagram shows the 64-point I/O Module's external parts.

(1) IO350 Module

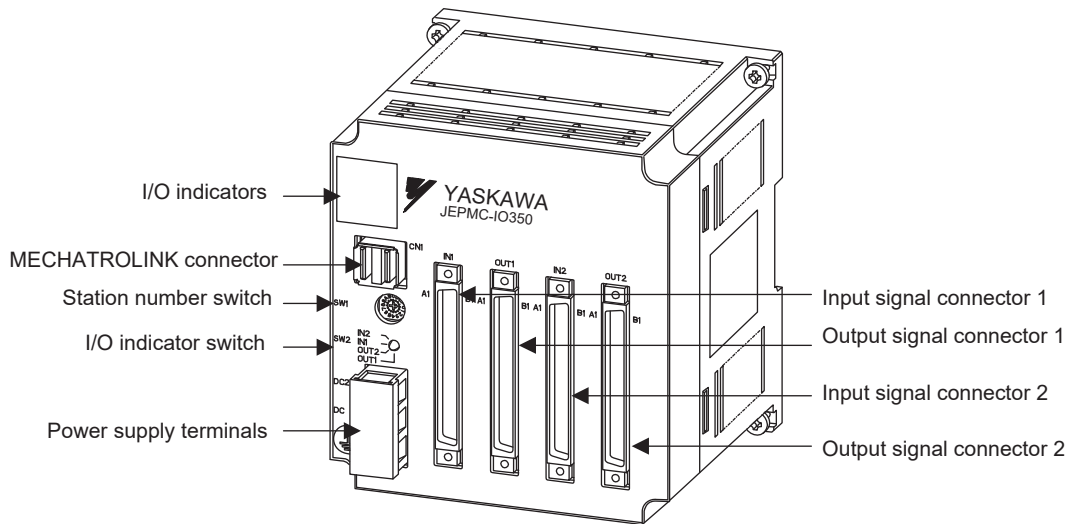

(2) IO2310/IO2330 Module

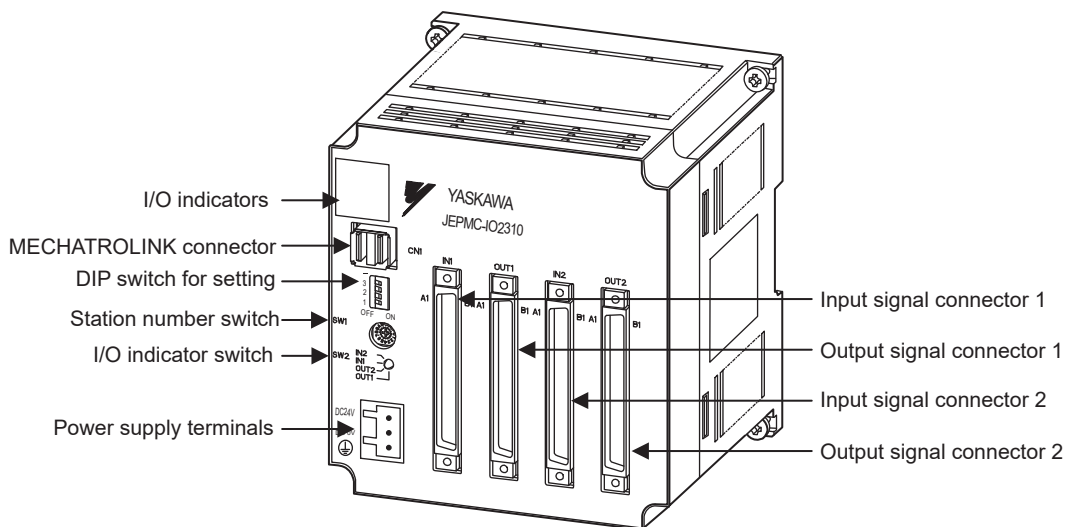

(3) I/O and Status Indicators

Indicator Name	Indicator Color	Meaning When Lit
R	Yellow	Not used. (Stays lit.)
ACTIVE	Yellow	Sending data through MECHATROLINK.
F	Red	Blown fuse
1 to 32	Yellow	Input signal and output signal monitors. The meaning of these indicators depends on the I/O indicator switch setting.

R	ACTIVE	F
1	9	17 25
2	10	18 26
3	11	19 27
4	12	20 28
5	13	21 29
6	14	22 30
7	15	23 31
8	16	24 32

(4) MECHATROLINK Connector

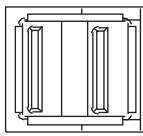

CN1 Connect through a MECHATROLINK Cable.

(5) I/O Signal Connector

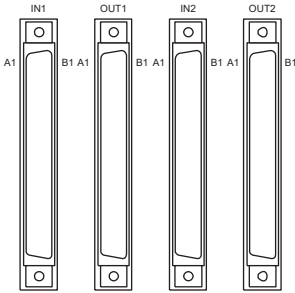

Connect the I/O Unit with external I/O signals through an I/O Cable.

Number of I/O points: 64 inputs and 64 outputs

(6) Station Number Switch



Sets the Module's station number in the MECHATROLINK system.

Setting range: 0 to E

Use a unique station number for each Unit if two or more Units are connected.

(7) I/O Indicator Switch

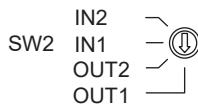

Selects which 32 I/O points are monitored by the I/O indicators.

IN1: Input signals 1 to 32

IN2: Input signals 33 to 64

OUT1: Output signals 1 to 32

OUT2: Output signals 33 to 64

(8) External Wiring Terminals

The external wiring terminal supplies 24 VDC to I/O Module.

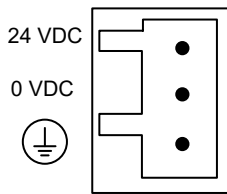

IO2310 Module

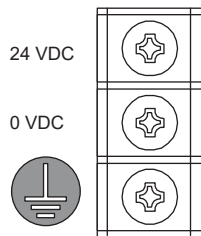

IO350 Module

Terminal Name	Function
DC24V	+24 VDC
DC0V	0 VDC
FG	Protective ground terminal

(9) DIP switch for Settings

A DIP switch, which is used to make settings for communications, is mounted on the IO2310 and IO2330 Modules.

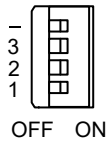

Display (Switch No.)	Name	Status	Function	Factory Setting
–	Reserved by system	–	Be sure to turn it OFF.	OFF
3	MECHATROLINK upper-place address setting	ON	7xh	OFF
		OFF	6xh	
2	I/O byte setting	ON	32-byte mode	OFF
		OFF	17-byte mode	
1	Baud rate setting	ON	10 Mbps	ON
		OFF	4 Mbps	



Set the IO2310/IO2330 communications in accordance with the settings of the host controller.

For example, when the communication setting is 10 Mbps and 32-byte mode, set both of switch 1 “baud rate setting” and switch 2 “I/O byte setting” to ON.

(10) Slave Address Setting

Set the I/O Module slave address as shown below.

(a) IO350 Slave Address

Station Address	Station Number Switch
1(61h)	1
2(62h)	2
3(63h)	3
4(64h)	4
5(65h)	5
6(66h)	6
7(67h)	7
8(68h)	8
9(69h)	9
10(6Ah)	A
11(6Bh)	B
12(6Ch)	C
13(6Dh)	D
14(6Eh)	E

The data in the parentheses indicate the MECHATROLINK addresses.

(b) IO2310/IO2330 Slave Address

Station Address	DIP switch for "3"	Station Number Switch	Station Address	DIP switch for "3"	Station Number Switch
1(61h)	OFF	1	16(70h)	ON	0
2(62h)	OFF	2	17(71h)	ON	1
3(63h)	OFF	3	18(72h)	ON	2
4(64h)	OFF	4	19(73h)	ON	3
5(65h)	OFF	5	20(74h)	ON	4
6(66h)	OFF	6	21(75h)	ON	5
7(67h)	OFF	7	22(76h)	ON	6
8(68h)	OFF	8	23(77h)	ON	7
9(69h)	OFF	9	24(78h)	ON	8
10(6Ah)	OFF	A	25(79h)	ON	9
11(6Bh)	OFF	B	26(7Ah)	ON	A
12(6Ch)	OFF	C	27(7Bh)	ON	B
13(6Dh)	OFF	D	28(7Ch)	ON	C
14(6Eh)	OFF	E	29(7Dh)	ON	D
15(6Fh)	OFF	F	Not used	ON	E, F

The data in the parentheses indicate the MECHATROLINK addresses.

4.1.2 Performance Specifications

The performance specifications of IO350/IO2310/IO2330 Module are shown below.

Item	Specifications
Name	64-point I/O Module
Model Description	IO350/IO2310/IO2330
Model Number	JEPMC-IO350/JEPMC-IO2310/JEPMC-IO2330
External Power Supply	24 VDC (20.4 to 28.8VDC)
Rated Current	0.5A
Inrush Current	1A
Dimensions (mm)	120 × 130 × 105 (W × H × D)

(1) Input Circuit

The input circuit specifications are shown below. The input circuit is used both for IO350, IO2310, and IO2330 Modules.

Item	Specifications
Number of Input Points	64 points (32 points × 2)
Input Type	Sinking or sourcing
Isolation Method	Photocoupler
Input Voltage	24 VDC (20.4 to 28.8 VDC)
Input Current	5 mA/point
ON Voltage/Current	9V min./1.6 mA min.
OFF Voltage/Current	7V max./1.3 mA max.
ON Time/OFF Time	ON time: 2 ms, OFF time: 3 ms
Input Points per Common	16 points per common (1 to 16, 17 to 32, 33 to 48, 49 to 64)

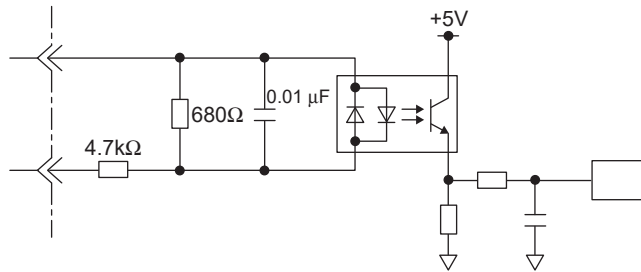

Input Circuit

(2) Output Circuit

The output circuit specifications are shown below.

Item	Specifications	
	Module	IO350/IO2310
Number of Output Points	64 points (32 points × 2)	
Output Type	Transistor, open collector, or sinking	Transistor, open collector, or sourcing
Isolation Method	Photocoupler	
Output Voltage	24 VDC (20.4 to 28.8 VDC)	
Output Current	50 mA/point	
Leakage Current when OFF	0.1 mA max.	
ON Time/OFF Time	ON time: 2 ms max., OFF time: 4 ms max.	
Output Points per Common	16 points per common (1 to 16, 17 to 32, 33 to 48, 49 to 64)	
Fuses	A fuse for each common point to prevent fire caused by the output short-circuit	
Error Detection	Blown fuse detection	

(a) Circuit Diagram of IO350 and IO2310

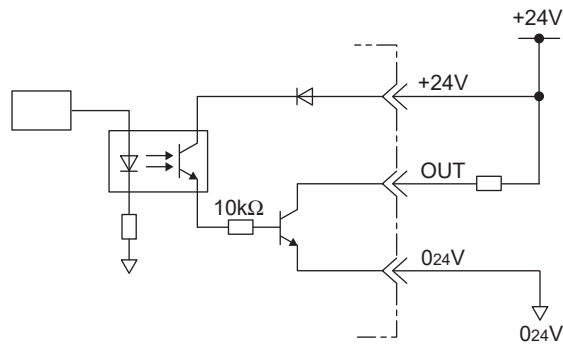

Output Circuit

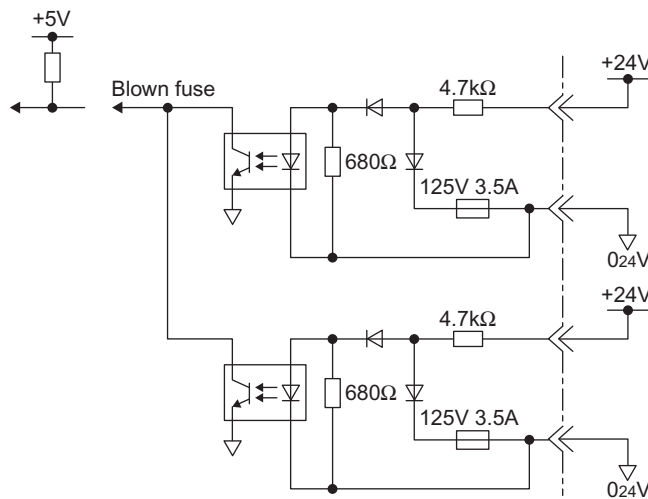

Blown Fuse Detection Circuit

(b) Circuit Diagram of IO2330

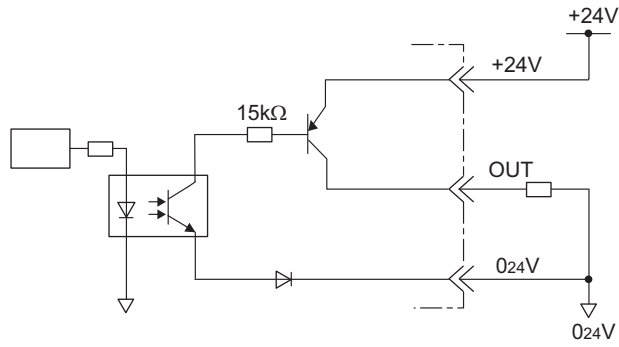

Output Circuit

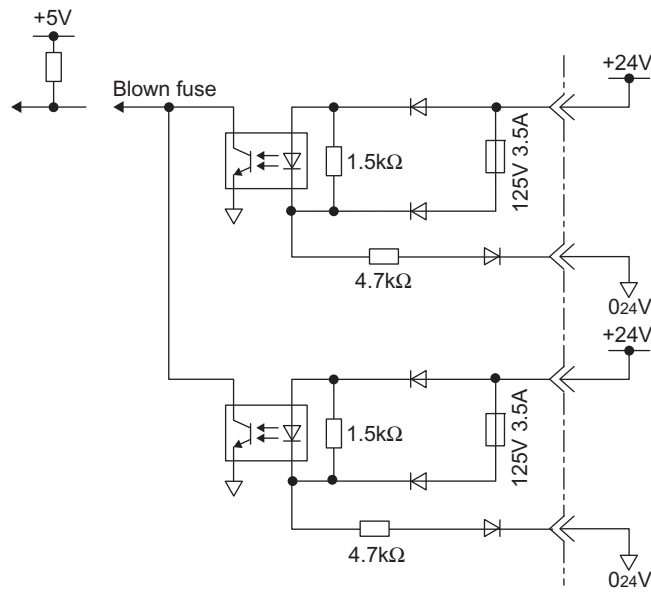

Blown Fuse Detection Circuit

4.1.3 System Connection

(1) Connector Specifications

The following table shows the connector specifications. The I/O connector is used both for IO350, IO2310, and IO2330 Modules.

Name	Number of Pins	Connector Model			
		Module Side	Manufacturer	Cable Side	Manufacturer
I/O connector	40	FCN-365P040-AU#01	Fujitsu Component Limited	FCN-360C040-E (cover) FCN-361J040-AU	Fujitsu Component Limited
		N365P040AU01	OTAX Corporation	N360C040E (cover) N361J040AU	OTAX Corporation

(2) Standard Cable and Appearance

The following table shows the standard cable models and appearance. The standard cable is used both for IO350, IO2310, and IO2330 Modules.

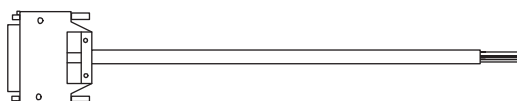
Name	Model	Length (m)	Appearance (JEPMC-W5410-□□)
I/O Cable	JEPMC-W5410-05	0.5	
	JEPMC-W5410-10	1	
	JEPMC-W5410-30	3	

(3) Standard Cable Wire Table

The wiring table for the standard cable JEPMC-W5410-□□ is shown below.

No.	Cable Color	Dot Mark Color	Dot Mark
A1	blue	red	—
B1	blue	black	—
A2	pink	red	—
B2	pink	black	—
A3	green	red	—
B3	green	black	—
A4	orange	red	—
B4	orange	black	—
A5	gray	red	—
B5	gray	black	—
A6	blue	red	--
B6	blue	black	--
A7	pink	red	--
B7	pink	black	--
A8	green	red	--
B8	green	black	--
A9	orange	red	--
B9	orange	black	--
A10	gray	red	--
B10	gray	black	--

No.	Cable Color	Dot Mark Color	Dot Mark
A11	blue	red	----
B11	blue	black	----
A12	pink	red	----
B12	pink	black	----
A13	green	red	----
B13	green	black	----
A14	orange	red	----
B14	orange	black	----
A15	gray	red	----
B15	gray	black	----
A16	blue	red	-----
B16	blue	black	-----
A17	pink	red	-----
B17	pink	black	-----
A18	green	red	-----
B18	green	black	-----
A19	orange	red	-----
B19	orange	black	-----
A20	gray	red	-----
B20	gray	black	-----

(4) Connector Pin Layout

The pin layout of the I/O connectors are the same for the IO350, IO2310, and IO2330 modules.

(a) Input Signal Connector IN1

The following table shows the pin layout of the IN1 connector.

No.	Signal Name	Remarks	No.	Signal Name	Remarks
A1	(NC)		B1	(NC)	
A2	+24V_2	24-V power supply 2	B2	+24V_2	24-V power supply 2
A3	IN32	Input 32	B3	IN31	Input 31
A4	IN30	Input 30	B4	IN29	Input 29
A5	IN28	Input 28	B5	IN27	Input 27
A6	IN26	Input 26	B6	IN25	Input 25
A7	IN24	Input 24	B7	IN23	Input 23
A8	IN22	Input 22	B8	IN21	Input 21
A9	IN20	Input 20	B9	IN19	Input 19
A10	IN18	Input 18	B10	IN17	Input 17
A11	IN16	Input 16	B11	IN15	Input 15
A12	IN14	Input 14	B12	IN13	Input 13
A13	IN12	Input 12	B13	IN11	Input 11
A14	IN10	Input 10	B14	IN09	Input 9
A15	IN08	Input 8	B15	IN07	Input 7
A16	IN06	Input 6	B16	IN05	Input 5
A17	IN04	Input 4	B17	IN03	Input 3
A18	IN02	Input 2	B18	IN01	Input 1
A19	(NC)		B19	(NC)	
A20	+24V_1	24-V power supply 1	B20	+24V_1	24-V power supply 1

Note: The +24V_1 is used for IN01 to IN6; +24V_2 is used for IN17 to IN32.

(b) Input Signal Connector IN2

The following table shows the pin layout of the IN2 connector.

No.	Signal Name	Remarks	No.	Signal Name	Remarks
A1	(NC)		B1	(NC)	
A2	+24V_4	24-V power supply 4	B2	+24V_4	24-V power supply 4
A3	IN64	Input 64	B3	IN63	Input 63
A4	IN62	Input 62	B4	IN61	Input 61
A5	IN60	Input 60	B5	IN59	Input 59
A6	IN58	Input 58	B6	IN57	Input 57
A7	IN56	Input 56	B7	IN55	Input 55
A8	IN54	Input 54	B8	IN53	Input 53
A9	IN52	Input 52	B9	IN51	Input 51
A10	IN50	Input 50	B10	IN49	Input 49
A11	IN48	Input 48	B11	IN47	Input 47
A12	IN46	Input 46	B12	IN45	Input 45
A13	IN44	Input 44	B13	IN43	Input 43
A14	IN42	Input 42	B14	IN41	Input 41
A15	IN40	Input 40	B15	IN39	Input 39
A16	IN38	Input 38	B16	IN37	Input 37
A17	IN36	Input 36	B17	IN35	Input 35
A18	IN34	Input 34	B18	IN33	Input 33
A19	(NC)		B19	(NC)	
A20	+24V_3	24-V power supply 3	B20	+24V_3	24-V power supply 3

Note: The +24V_3 is used for IN33 to IN48; +24V_4 is used for IN49 to IN64.

(c) Output Signal Connector OUT1

The following table shows the pin layout of the OUT1 connector.

No.	Signal Name	Remarks	No.	Signal Name	Remarks
A1	024V_6	Common ground 6	B1	024V_6	Common ground 6
A2	+24V_6	24-V power supply 6	B2	+24V_6	24-V power supply 6
A3	OUT32	Output 32	B3	OUT31	Output 31
A4	OUT30	Output 30	B4	OUT29	Output 29
A5	OUT28	Output 28	B5	OUT27	Output 27
A6	OUT26	Output 26	B6	OUT25	Output 25
A7	OUT24	Output 24	B7	OUT23	Output 23
A8	OUT22	Output 22	B8	OUT21	Output 21
A9	OUT20	Output 20	B9	OUT19	Output 19
A10	OUT18	Output 18	B10	OUT17	Output 17
A11	OUT16	Output 16	B11	OUT15	Output 15
A12	OUT14	Output 14	B12	OUT13	Output 13
A13	OUT12	Output 12	B13	OUT11	Output 11
A14	OUT10	Output 10	B14	OUT09	Output 9
A15	OUT08	Output 8	B15	OUT07	Output 7
A16	OUT06	Output 6	B16	OUT05	Output 5
A17	OUT04	Output 4	B17	OUT03	Output 3
A18	OUT02	Output 2	B18	OUT01	Output 1
A19	024V_5	Common ground 5	B19	024V_5	Common ground 5
A20	+24V_5	24-V power supply 5	B20	+24V_5	24-V power supply 5

Note: The +24V_5 and 024V_5 are used for OUT01 to OUT16. +24V_6 and 024V_6 are used for OUT17 to OUT32.

(d) Output Signal Connector OUT2

The following shows the pin layout of the OUT2 connector.

No.	Signal Name	Remarks	No.	Signal Name	Remarks
A1	024V_8	Common ground 8	B1	024V_8	Common ground 8
A2	+24V_8	24-V power supply 8	B2	+24V_8	24-V power supply 8
A3	OUT64	Output 64	B3	OUT63	Output 63
A4	OUT62	Output 62	B4	OUT61	Output 61
A5	OUT60	Output 60	B5	OUT59	Output 59
A6	OUT58	Output 58	B6	OUT57	Output 57
A7	OUT56	Output 56	B7	OUT55	Output 55
A8	OUT54	Output 54	B8	OUT53	Output 53
A9	OUT52	Output 52	B9	OUT51	Output 51
A10	OUT50	Output 50	B10	OUT49	Output 49
A11	OUT48	Output 48	B11	OUT47	Output 47
A12	OUT46	Output 46	B12	OUT45	Output 45
A13	OUT44	Output 44	B13	OUT43	Output 43
A14	OUT42	Output 42	B14	OUT41	Output 41
A15	OUT40	Output 40	B15	OUT39	Output 39
A16	OUT38	Output 38	B16	OUT37	Output 37
A17	OUT36	Output 36	B17	OUT35	Output 35
A18	OUT34	Output 34	B18	OUT33	Output 33
A19	024V_7	Common ground 7	B19	024V_7	Common ground 7
A20	+24V_7	24-V power supply 7	B20	+24V_7	24-V power supply 7

Note: The +24V_7 and 024V_7 are used for OUT33 to OUT48; +24V_8 and 024V_8 are used for OUT49 to OUT64.

(5) Connection Examples

The following diagram shows an example of how the I/O connectors are usually connected.

(a) Input Signal Connector IN1

The following diagram shows an example of how the IN1 input-signal connector is usually connected. The same connection is applicable for the IO350, the IO2310, and the IO2330 modules.

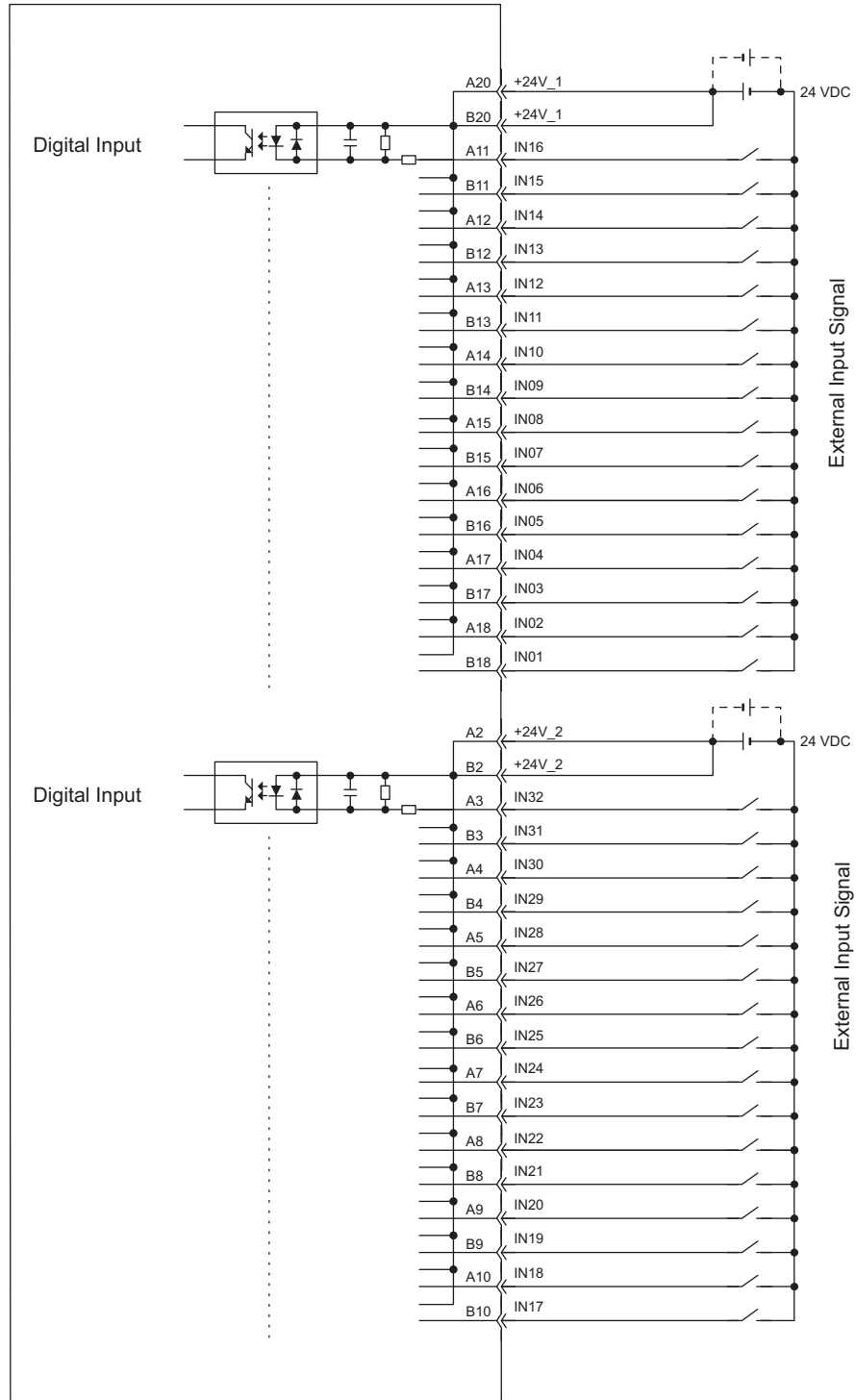

(b) Input Signal Connector IN2

The following diagram shows an example of how the IN2 input signal connector is usually connected. The same connection is applicable for the IO350, the IO2310, and the IO2330.

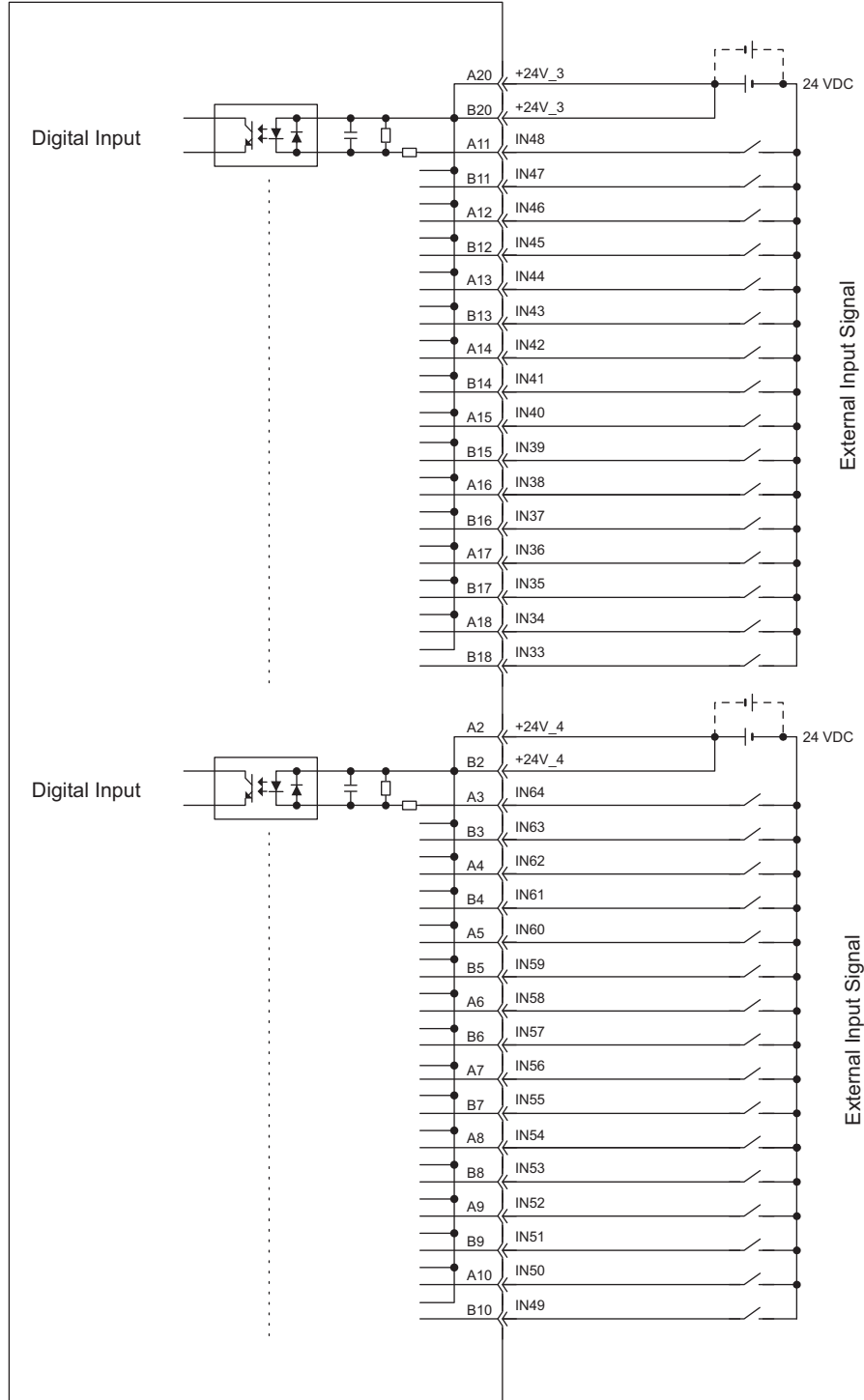

(c) Output Signal Connector OUT1

The following diagram shows an example of how the OUT1 output signal connector is usually connected.

- Typical Connection of the IO350 and the IO2310 Modules

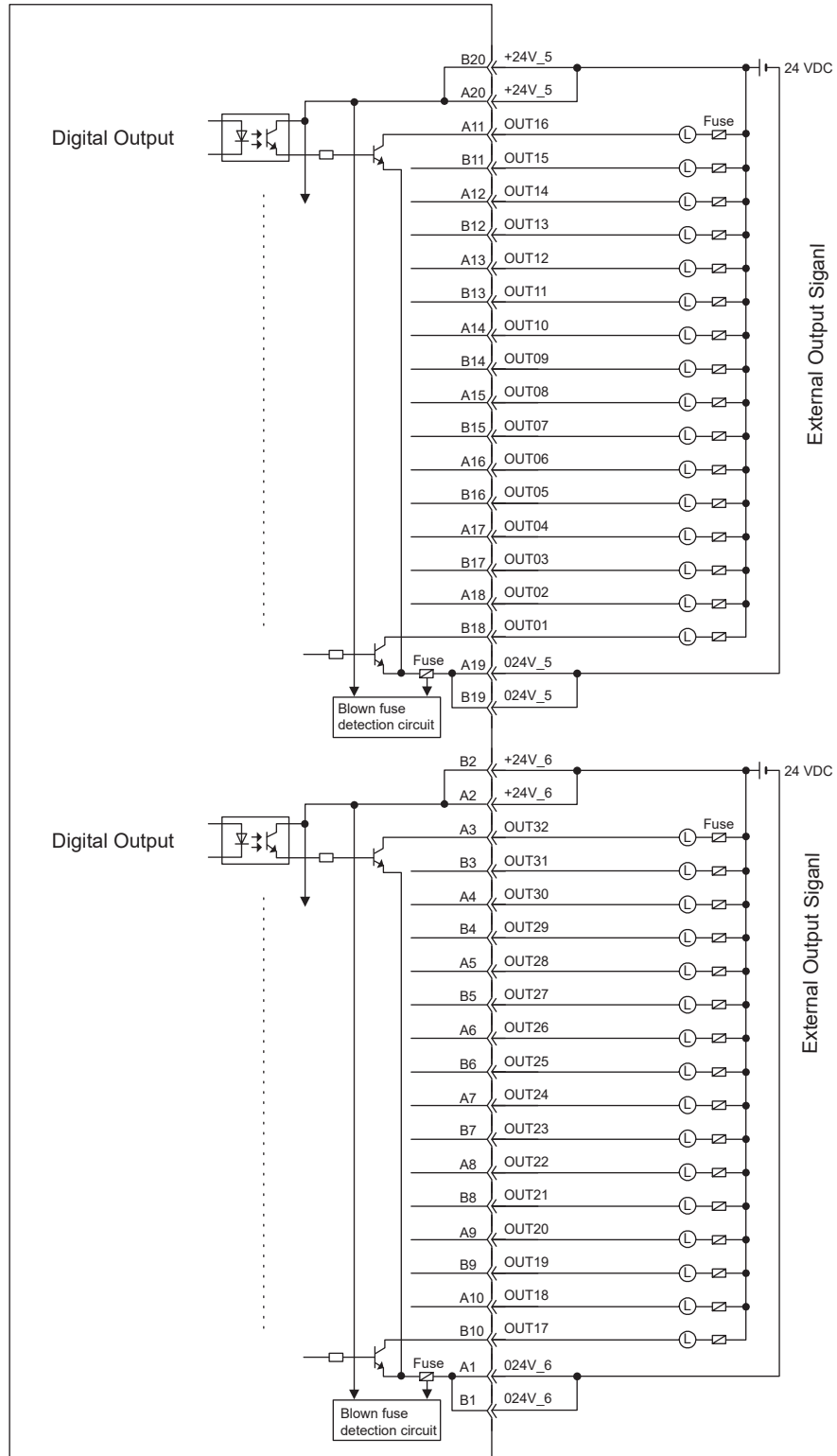

Note: Connect an externally fuse that is in accordance with the load specifications and has a load in series to the output signal circuit. If an overload or a load short-circuit occurs without an external fuse being connected, fire, destruction of the load unit, or damages to the output elements may result.

• Typical Connection of IO2330

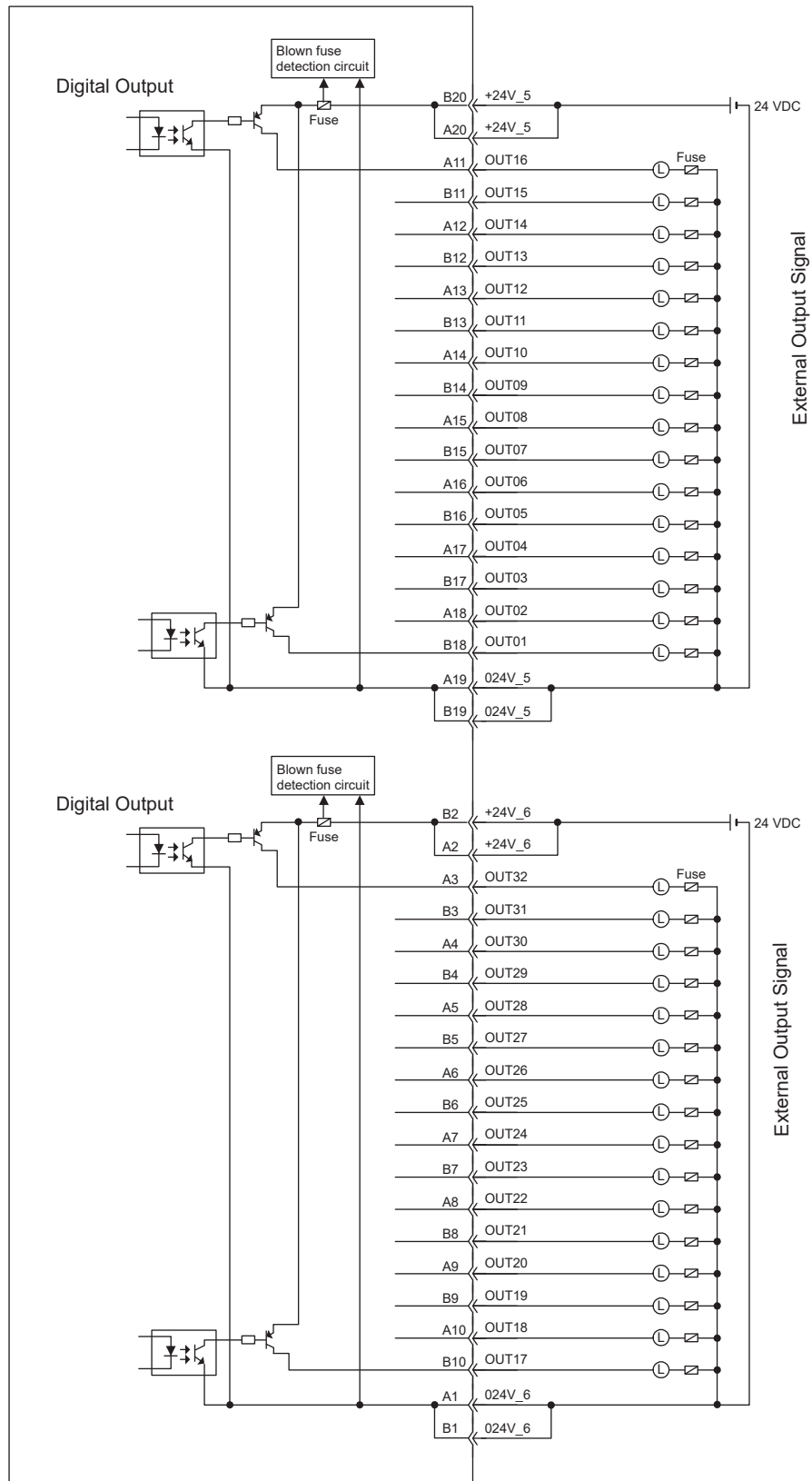

Note: Connect an externally fuse that is in accordance with the load specifications and has a load in series to the output signal circuit. If an overload or a load short-circuit occurs without an external fuse being connected, fire, destruction of the load unit, or damages to the output elements may result.

(d) Output Signal Connector OUT2

The following diagram shows typical connection of OUT2 output signal connector.

- Typical Connection of IO350 and IO2310

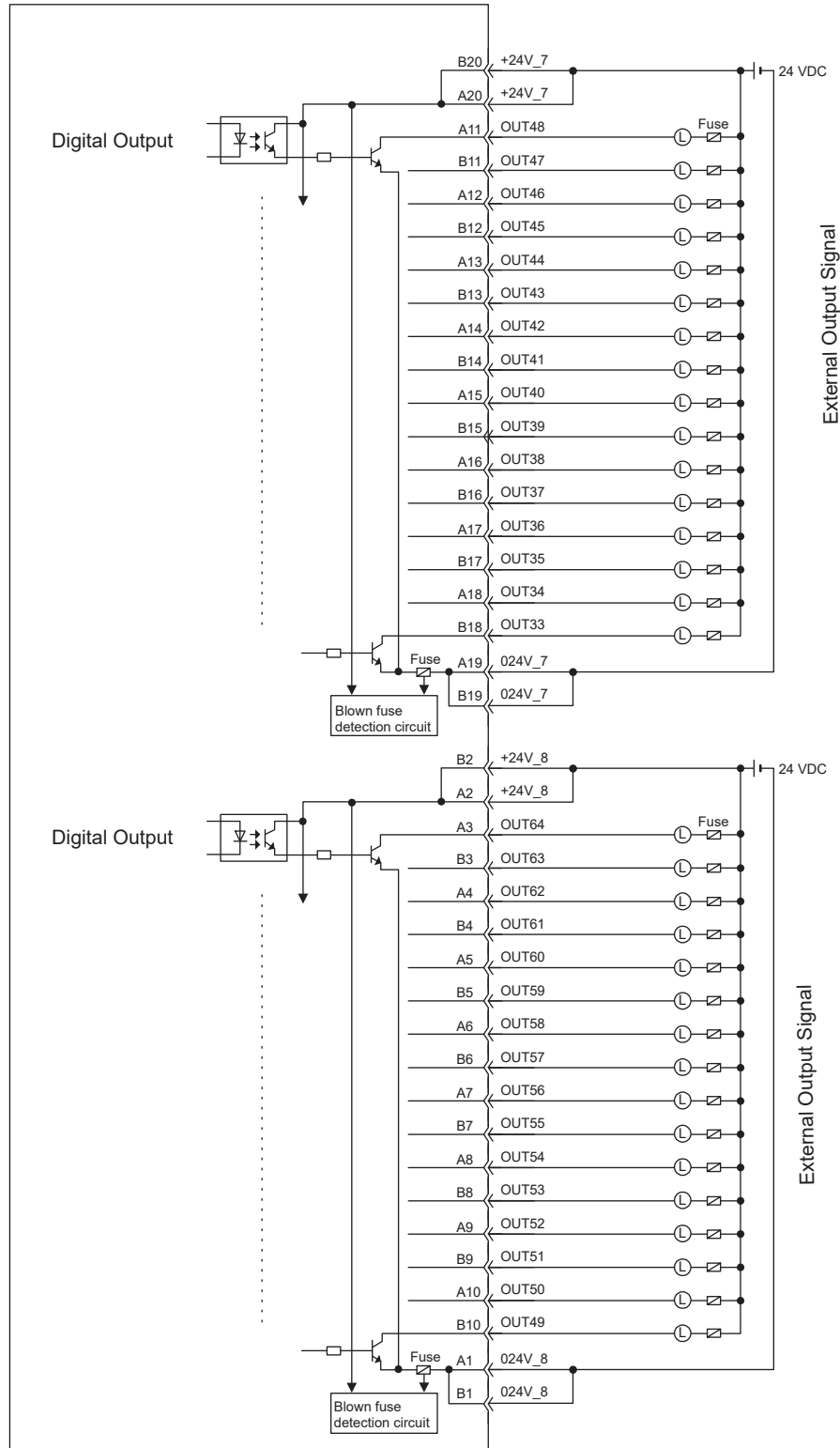

Note: Connect an externally fuse that is in accordance with the load specifications and has a load in series to the output signal circuit. If an overload or a load short-circuit occurs without an external fuse being connected, fire, destruction of the load unit, or damages to the output elements may result.

• Typical Connection of IO2330

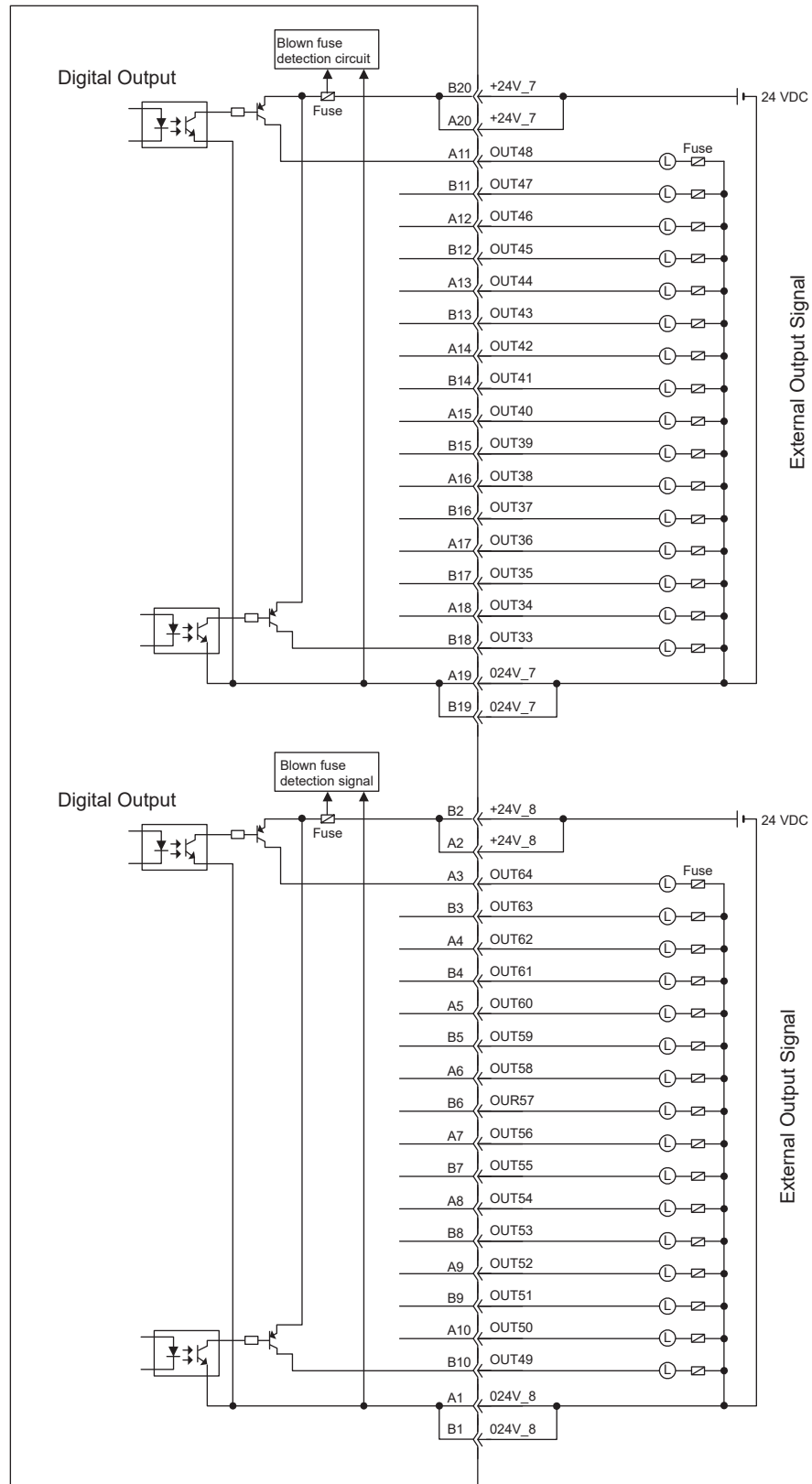

Note: Connect an externally fuse that is in accordance with the load specifications and has a load in series to the output signal circuit. If an overload or a load short-circuit occurs without an external fuse being connected, fire, destruction of the load unit, or damages to the output elements may result.

(6) Example of System Connections

The following example shows the connections in a system that uses an IO2310 Module.

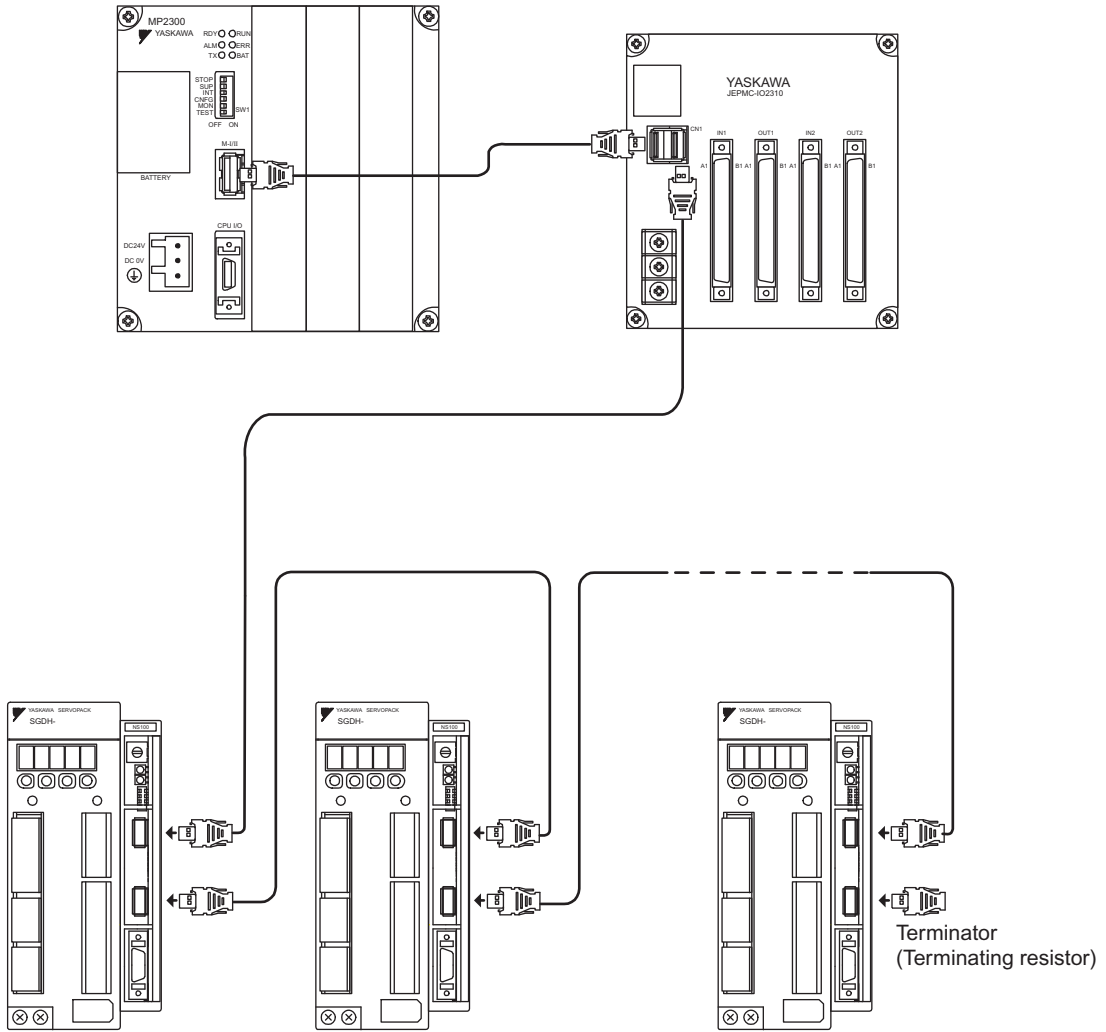

4.2 Wildcard I/O Modules (□□□□□I/O)

The Wildcard I/O Modules are virtual Distributed I/O Modules that can represent other Modules such as ones that will be developed in the future. A virtual Distributed I/O Module can be used temporarily when the MPE720 software for Programming Device is not compatible. The number of I/O points is not fixed so the user can set the number of I/O points as needed. Up to 16 words of data can be set. Refer to *Chapter 2 I/O Allocations* for details.

Reversible Counter Module with Preset Function

This section provides an overview of the Reversible Counter Module with Preset Function (120EHC21140)/(PL2900).

5.1 Summary of Module Functions	5-2
5.1.1 High-speed Pulse Counting Function	5-2
5.1.2 Notch Signal Output Function	5-3
5.1.3 Current Value Setting	5-5
5.2 External Appearance and Configuration	5-6
5.3 System Configuration	5-11
5.3.1 Example of System Configuration	5-11
5.3.2 Interface with the Host Controller	5-12
5.4 Specifications	5-13
5.4.1 General Specifications	5-13
5.4.2 Performance Specifications	5-14
5.5 External I/O Signals and Connection Examples	5-24
5.5.1 Overview	5-24
5.5.2 Connection Examples of External I/O Terminals	5-25
5.5.3 I/O Allocations	5-32
5.5.4 Output Coils	5-34
5.5.5 Output Registers	5-35
5.5.6 Input Relays	5-36
5.5.7 Input Registers	5-37
5.5.8 Monitoring Data	5-38
5.6 Precautions on Wiring	5-42
5.6.1 External Pulse Input Circuit (Phase-A Pulse, Phase-B Pulse)	5-42
5.6.2 External Input Circuit (External Latch and External Current Value Reset Functions)	5-44
5.6.3 External Output Circuit (External Notch Output)	5-47
5.7 Module Operation	5-49
5.7.1 Operation Settings	5-49
5.7.2 Ladder Programs	5-54

5.1 Summary of Module Functions

There are two types of Counter Modules available as described below.

- JAMSC-120EHC21140: Module with baud rate of 4 Mbps/1 Mbps
- JEPMC-PL2900: Module with baud rate of 10 Mbps/4 Mbps

Only the MECHATROLINK with baud rate differs between these Modules. For operation, the DIP switch settings are also different, however, the functions are the same as the Counter Modules.

This section describes the operations that can be performed with the Counter Module.

5.1.1 High-speed Pulse Counting Function

The Counter Module can count high-speed pulses input from a pulse source such as a rotary encoder.

◀ EXAMPLE ▶

The following timing chart shows an example of high-speed counter operation

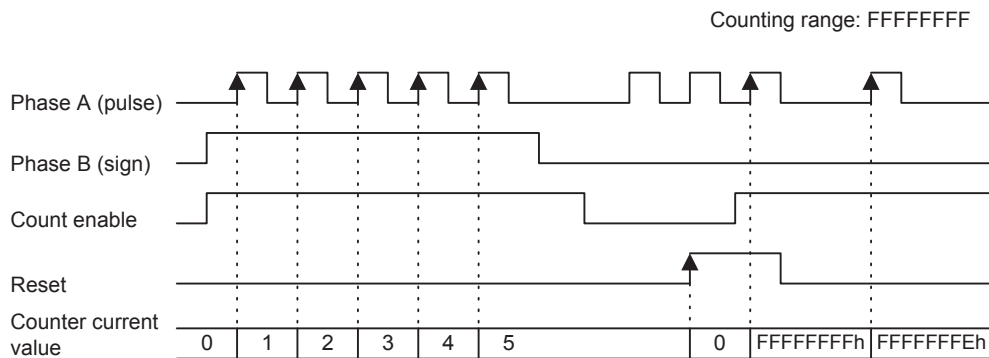

The high-speed pulse counting function has the following capabilities.

(1) Counting Method

- Phase-A and phase-B pulses ($\times 1$, $\times 2$, or $\times 4$ multiplication)
- Sign and pulse ($\times 1$ or $\times 2$ multiplication)
- Increment and decrement pulses ($\times 1$ or $\times 2$ multiplication)

(2) Counting Speed

- 300 kpps ($\times 1$ multiplication)
- 600 kpps ($\times 2$ multiplication)
- 1,200 kpps ($\times 4$ multiplication)

(3) Counting Range

32 bits (0 to 4,294,967,295 (FFFFFFF hexadecimal))

5.1.2 Notch Signal Output Function

The Counter Module can compare the pulse count with the notch point set value (set in advance) and output a digital notch signal to an external device such as a relay.

◀ **EXAMPLE** ▶

The following timing chart shows an example of the notch signal output function

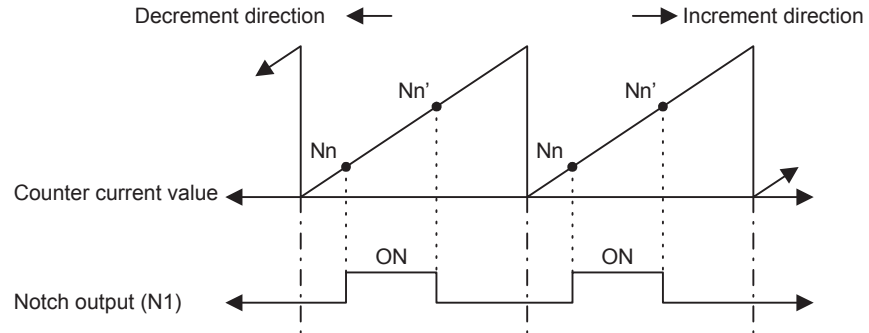

The notch signal output function has the following capabilities.

(1) Output Mode

There are three output modes: State mode, latch mode, and special state mode. Select either mode.

(a) State Mode

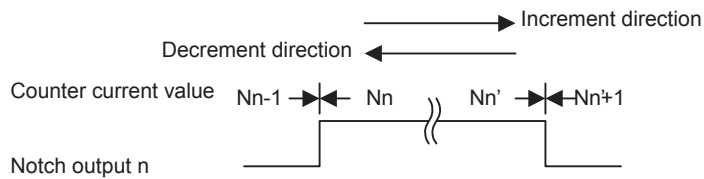

The following timing chart shows the output pattern of the notch output signal when the function is in state mode and $N_n < N_n'$.

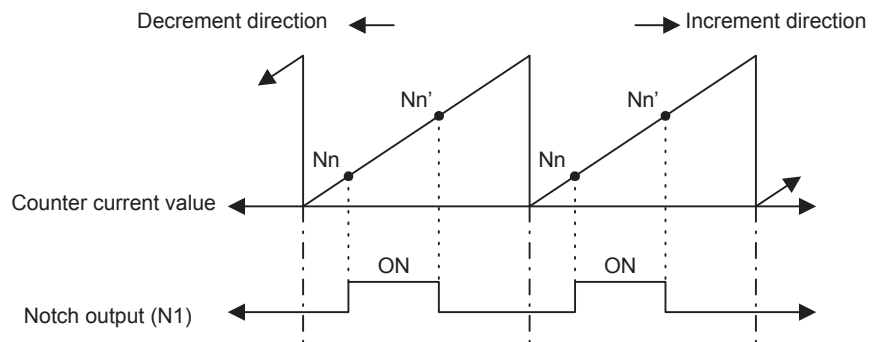

(b) Latch Mode

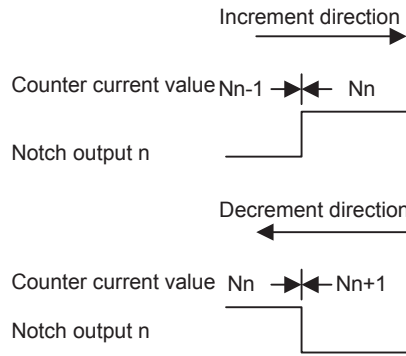

The following timing chart shows the output pattern of the notch output signal when the function is in latch mode.

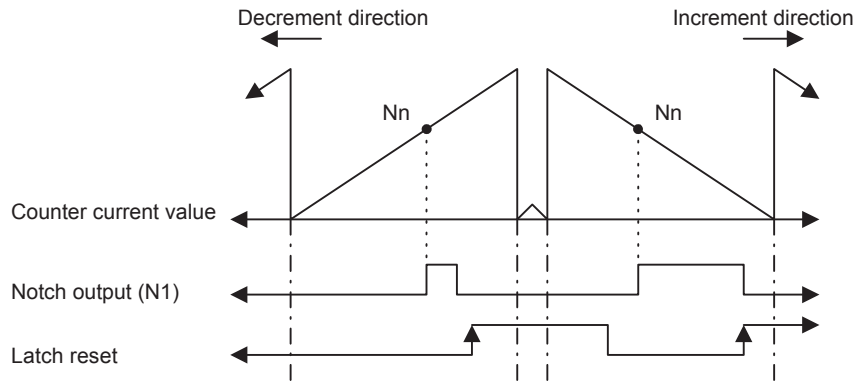

(c) Special State Mode

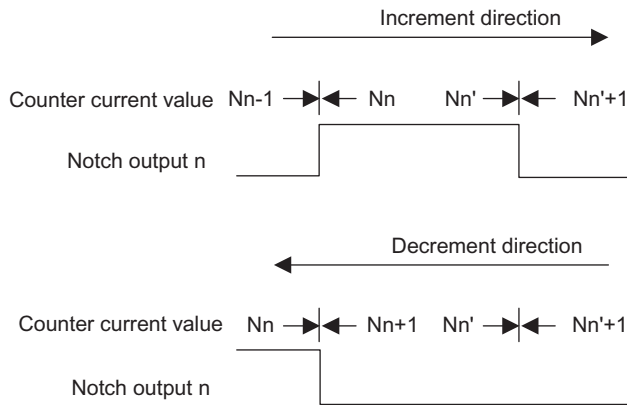

The following timing chart shows the output pattern of the notch output signal when the function is in special state mode.

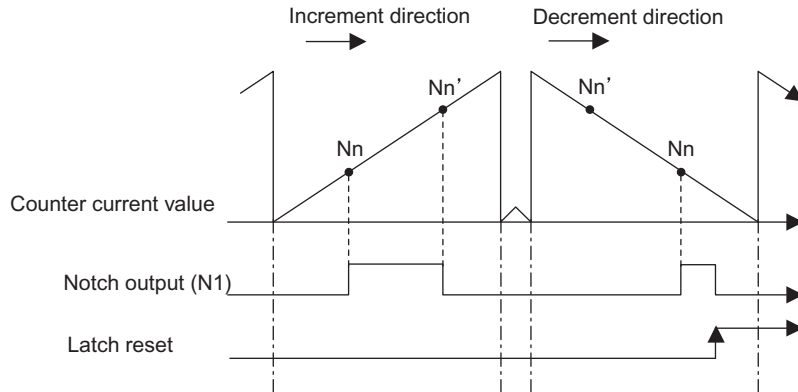

(2) Number of Outputs

The number of outputs is 1 output/channel.

5.1.3 Current Value Setting

The current value setting can be used to set the current value in the Counter Module. The current value is set in the output registers and then set in the Counter Module using Current Value Set Output Coil.

5.2 External Appearance and Configuration

The following diagram shows the Counter Module's external parts.

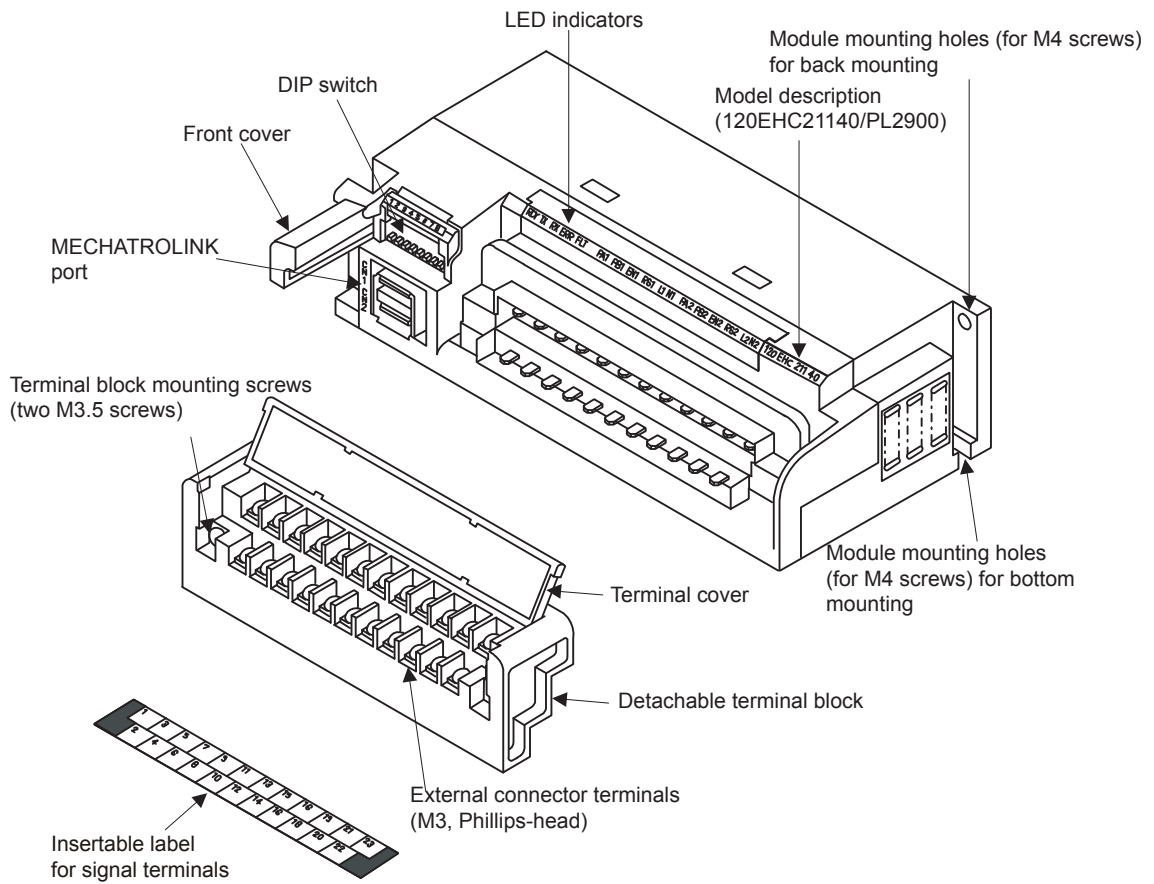

(1) LED Indicators

The following table shows the contents of the Counter Module's LED indicators

RDY	TX	RX	ERR	FLT	PA1	PB1	EN1	RS1	L1	N1	PA2	PB2	EN2	RS2	L2	N2
-----	----	----	-----	-----	-----	-----	-----	-----	----	----	-----	-----	-----	-----	----	----

Indicator LED	Indicator Color	Status	Meaning When Lit or Flashing
RDY	Green	Lit	The Module is operating normally.
		Flashing	The transmission cable is disconnected or the Module is waiting for communication with the master.
TX	Green	Lit	Data is being transmitted.
RX	Green	Lit	Data is being received.
ERR	Red	Lit	A communication error occurred.
FLT	Red	Lit	A setting error occurred.
		Flashing	A self-diagnostic error occurred.
PA1	Green	Lit	The counter 1 phase-A pulse is being input.
PB1	Green	Lit	The counter 1 phase-B pulse is being input.
EN1	Green	Lit	Counter 1 counting is enabled.
RS1	Green	Lit	The counter 1 external reset input is being input.
L1	Green	Lit	The counter 1 external latch input is being input.*
N1	Green	Lit	The counter 1 notch output is being output.
PA2	Green	Lit	The counter 2 phase-A pulse is being input.
PB2	Green	Lit	The counter 2 phase-B pulse is being input.
EN2	Green	Lit	The counter 2 counting is enabled.
RS2	Green	Lit	The counter 2 external reset input is being input.
L2	Green	Lit	The counter 2 external latch input is being input.*
N2	Green	Lit	The counter 2 notch output is being output.

* The LED indicator will remain lit even after the external latch input goes OFF as long as its data is retained in the Module. The indicator can be turned OFF by turning ON the L-RESn Bit for the digital output.

(2) DIP Switch Settings

The settings for the Counter Module's DIP switch are explained below.

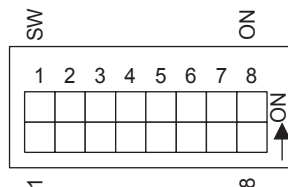

(a) EHC21140 Module

Pin No.	Setting	Function	Factory Setting
1 to 5	ON	Pins 1 through 5 set the Counter Module's slave address. (See the table on the following page.)	1: ON 2 to 5: OFF
	OFF		
6	ON	Sets the Counter Module's baud rate to 1 Mbps.	OFF
	OFF	Sets the Counter Module's baud rate to 4 Mbps.	
7	ON	Continues counting even if communication stops.	OFF
	OFF	Stops counting when communication stops.	OFF
8	ON	Reserved for future use. Leave pin 8 OFF.	OFF
	OFF		

(b) PL2900 Module

Pin No.	Setting	Function	Factory Setting
1 to 5	ON	Pins 1 through 5 set the Counter Module's slave address. (See the table on the following page.)	1: ON 2 to 5: OFF
	OFF		
6	ON	When SW8 turns ON, set the communication data length to 32 bytes. When SW8 turns OFF, set SW6 to OFF, too.	OFF
	OFF	When SW8 turns ON, set the communication data length to 17 bytes. When SW8 turns OFF, set SW6 to OFF, too.	
7	ON	Continues counting even if communication stops.	OFF
	OFF	Stops counting when communication stops.	OFF
8	ON	Sets the Counter Module's baud rate to 10 Mbps.	ON
	OFF	Sets the Counter Module's baud rate to 4 Mbps.	

IMPORTANT

New settings on pins 6 and 7 become effective when the main external power supply (24 VDC) is turned ON. When changing the setting, turn the Module's main external power supply (24 VDC) OFF and then ON again. PL2900 Module does not operate at 1-Mbps baud rate.

The following table shows the possible slave address settings.

Slave Address	DIP Switch Pins					Slave Address	DIP Switch Pins				
	1	2	3	4	5		1	2	3	4	5
Not used	0	0	0	0	0	16	0	0	0	0	1
1	1	0	0	0	0	17	1	0	0	0	1
2	0	1	0	0	0	18	0	1	0	0	1
3	1	1	0	0	0	19	1	1	0	0	1
4	0	0	1	0	0	20	0	0	1	0	1
5	1	0	1	0	0	21	1	0	1	0	1
6	0	1	1	0	0	22	0	1	1	0	1
7	1	1	1	0	0	23	1	1	1	0	1
8	0	0	0	1	0	24	0	0	0	1	1
9	1	0	0	1	0	25	1	0	0	1	1
10	0	1	0	1	0	26	0	1	0	1	1
11	1	1	0	1	0	27	1	1	0	1	1
12	0	0	1	1	0	28	0	0	1	1	1
13	1	0	1	1	0	29	1	0	1	1	1
14	0	1	1	1	0	30	0	1	1	1	1
15	1	1	1	1	0	Not used	1	1	1	1	1

Note: ON is 1. OFF is 0.



The upper limit of an effective slave address differs depending on the settings of the MECHATROLINK communication method (speed, cycle, etc.). For details, refer to the specifications of the communication method.

IMPORTANT

When the PL2900 Module is used at 10-Mbps baud rate, set the communication cycle to 1 ms or more.

(3) Terminal Block Terminal Layout

The following diagram shows the layout of terminals on the Counter Module's terminal block.

1	3 PHA1-	5 PHB1	7 PHB1+	9 N1	11 OUT-	13 N2	15 RST2	17 PHA2-	19 PHB2	21 PHB2+	23 +24V
2 PHA1	4 PHA1+	6 PHB1-	8 L1	10 RST1	12 IN-	14 L2	16 PHA2	18 PHA2+	20 PHB2-	22 024V	

Terminal No.	Signal Name	Signal Function
1	(open)	–
2	PHA1	Counter 1 phase-A input
3	PHA1-	
4	PHA1+	
5	PHB1	Counter 2 phase-B input
6	PHB1-	
7	PHB1+	
8	L1	Counter 1 latch input
9	N1	Counter 1 notch output
10	RST1	Counter 1 reset input
11	OUT-	Counters 1 and 2 external output common
12	IN-	Counters 1 and 2 external input common
13	N2	Counter 2 notch output
14	L2	Counter 2 latch output
15	RST2	Counter 2 reset input
16	PHA2	Counter 2 phase-A input
17	PHA2-	
18	PHA2+	
19	PHB2	Counter 2 phase-B input
20	PHB2-	
21	PHB2+	
22	024V	Main external power supply 0 V
23	+24V	Main external power supply +24 V

5.3 System Configuration

5.3.1 Example of System Configuration

The following diagram shows an example system configured for the Counter Module to count high-speed pulses from a rotary encoder.

An MP920 is used in this example.

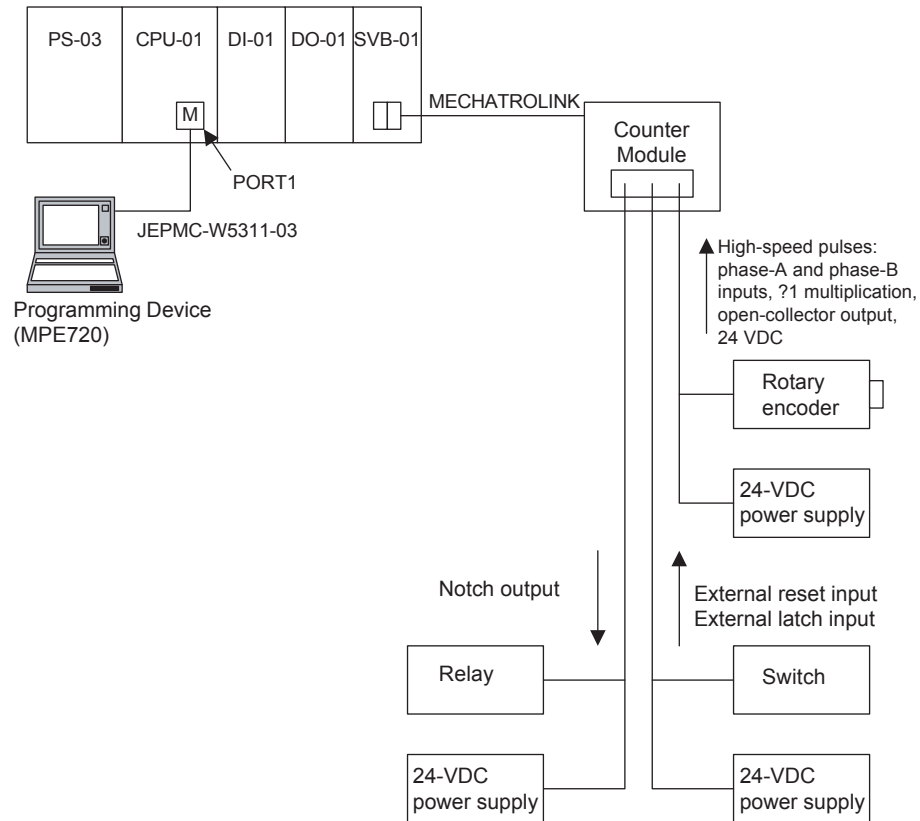

PS-03: Power Supply Module

CPU-01: MP920 CPU Module

DI-01: 24-VDC 64-point Input Module

DO-01: 24-VDC 64-point Output Module

SVB-01: MECHATROLINK Interface Module

JEPMC-W5311-03: MEMOBUS cable

(1) Maximum Number of Modules

Up to 14 Modules can be connected to a MECHATROLINK-I communication line.

Up to 21 Modules can be connected to a MECHATROLINK-II communication line.

For the overall system, the actual number of possible Modules will be determined by the number of sets of the following CPU Module I/O registers that are available for allocation.

- a) Seven consecutive words of input (I) registers
 - 2 working registers (IWxxxx)
 - 16 bits of input relays (IBxxxx0+20)
 - 4 input registers (IWxxxx+3)
- b) Eight consecutive words of output (O) registers
 - 2 working registers (OWxxxx)
 - 32 bits of output coils (OBxxxx0+20)
 - 4 output registers (OWxxxx+4)

(2) Mounting Position

The Module can be connected at any position on the MECHATROLINK communication line.

5.3.2 Interface with the Host Controller

The following diagram shows the interfaces between the Counter Module and the host controller and between the Counter Module and external devices.

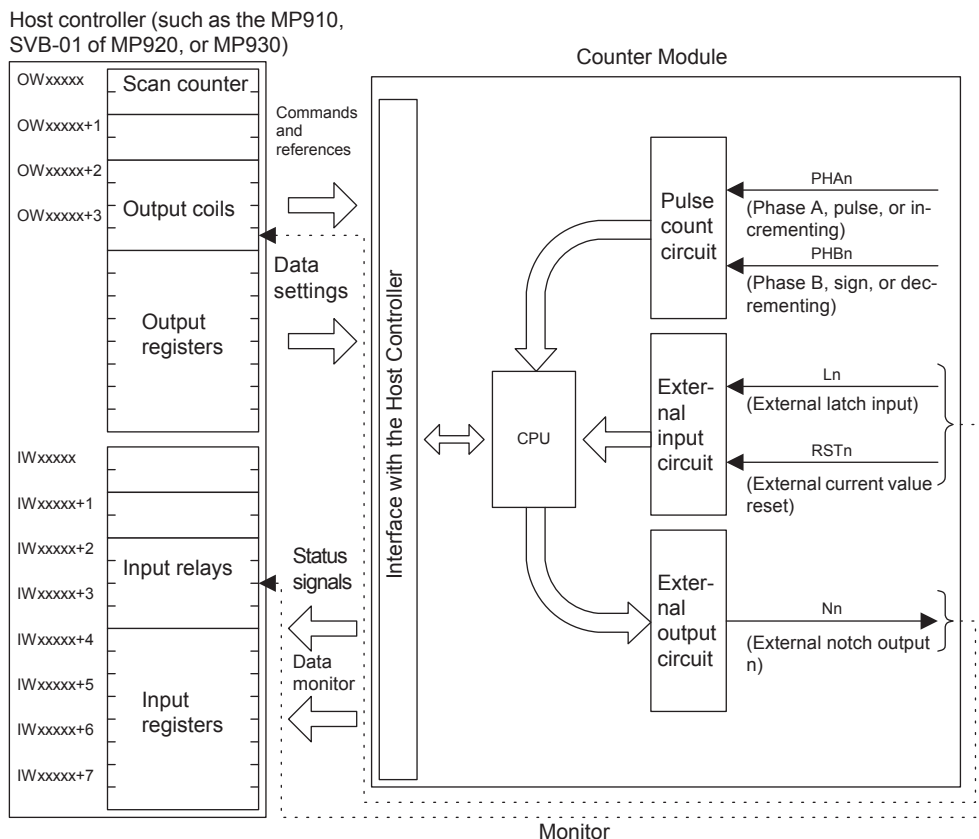

The following table explains the signals.

Name	Explanation	Reference
Scan counter	Monitor the host controller to process the 1scan in order to let the carry or the borrow signal of the input relay on 1scan.	—
Output coil	Contain the ON or OFF status of control signals from the host controller to the Module.	5.5.4 <i>Output Coils</i>
Output register	Contain numerical signals that convey the host controller's control references to the Counter Module. Used in combination with the output coils.	5.5.5 <i>Output Registers</i>
Input relay	Contain the ON or OFF status of status signals from the Counter Module to the host controller.	5.5.6 <i>Input Relays</i>
Input register	Contain numerical signals that convey the Counter Module's status to the host controller. Used in combination with the output coils.	5.5.7 <i>Input Registers</i>

IMPORTANT

Increase the Scan Counter by using the ladder program after setting the carry and the borrow signal as to the scan.

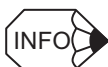

In order to monitor the carry or the borrow signal using the scan, INC OWxxxx ladder is necessary. Enter/Entry the ladder in/on the high-speed drawings, when using the carry or the borrow signal with the high-speed scan. If using the low-speed scan, enter/entry the ladder in/on the low-speed drawings.

5.4 Specifications

5.4.1 General Specifications

The general specifications of the Counter Module are shown below.

Item		Specification
Environmental Conditions	Ambient Operating Temperature	EHC21140 Module: 0 to 60°C PL2900 Module: 0 to 55 °C
	Storage Temperature	-25 to 85°C
	Operating Humidity	30% to 95% (with no condensation)
	Storage Humidity	5% to 95% (with no condensation)
	Pollution Level	Pollution level 1 according to JIS B 3501
	Corrosive Gas	No corrosive gas
	Operating Altitude	Less than 2,000 m above sea level
Mechanical Operating Conditions	Vibration Resistance	10 to 57 Hz with half-amplitude of 0.075 mm 57 to 150 Hz at fixed acceleration of 9.8 m/s ² (1 G) 10 sweeps in X, Y, and Z directions (sweep period: 1 octave/min) (conforming to JIS B 3502)
	Shock Resistance	Peak acceleration of 147 m/s ² (15 G) twice for 11 ms in X, Y, and Z directions (conforming to JIS B 3502)
Electrical Operating Conditions	Noise Resistance	1,000 Vp-p in normal mode with pulse widths of 100 ns and 1 ms and rise time of 1 ns (with impulse noise simulator) (conforming to JIS B 3502)
Dielectric Strength		1,500 VAC for 1 min or 1,800 VAC for 1 s between the I/O terminals and internal circuits, between I/O commons
Insulation Resistance		100 MΩ min. at 500 VDC between I/O terminals and ground (at room temperature and humidity)
Installation Requirements	Ground	Ground to 100 Ω or less
	Configuration	The Module can be mounted in three directions. Refer to 3.1.2 <i>Mounting Orientation</i> for details.
	Cooling Method	Natural cooling
	Mass	Approx. 300 g
	Dimensions (mm)	161 × 44 × 79 (W × H × D) (Not including the terminal block.)

5.4.2 Performance Specifications

(1) Hardware Specifications

The hardware specifications of the Counter Module are shown below.

Item		Specifications
Name		Two-channel Counter Module
Model Description		V_COUNT-2CH/PL2900
Model Number		JAMSC-120EHC21140, JEPMC-PL2900
Functions		Pulse counting and notch output
Number of Circuits		2 circuits
Communication Protocol		MECHATROLINK
I/O Allocations		32 output coils, 4 output registers 16 input relays, 4 input registers
I/O Signal Indication		PA1 lit: Counter 1 phase-A pulse is being input.
		PB1 lit: Counter 1 phase-B pulse is being input.
		EN1 lit: Counter 1 counting is enabled.
		RS1 lit: Counter 1 external reset input is being input.
		L1 lit: Counter 1 external latch input is being input.
		N1 lit: Counter 1 notch output is being output.
		PA2 lit: Counter 2 phase-A pulse is being input.
		PB2 lit: Counter 2 phase-B pulse is being input.
		EN2 lit: Counter 2 counting is enabled.
		RS2 lit: Counter 2 external reset input is being input.
		L2 lit: Counter 2 external latch input is being input.
		N2 lit: Counter 2 notch output is being output.
Status Indication		RDY lit: The Module is operating normally.
		RDY flashing: The transmission cable is disconnected or the Module is waiting for communication with the master.
		TX lit: Data is being transmitted.
		RX lit: Data is being received.
		ERR lit: A communication error occurred.
		FLT lit: A setting error occurred.
		FLT flashing: A self-diagnostic error occurred.
I/O Circuit Isolation	Insulation Method	Photocoupler
	Dielectric Strength	1,500 VAC for 1 minute between the I/O terminals and internal circuits
	Insulation Resistance	100 M Ω min. at 500 VDC between input terminals and internal circuits (at room temperature and humidity)
External Power Supply		Input signal power supply: 24 VDC Load driving power supply: 24 VDC Main external power supply: 24 VDC (20.4 to 26.4 V), 150 mA max.
Derating Conditions		The Module can be mounted in three directions. Refer to <i>3.1.2 Mounting Orientation</i> for details.
Maximum Heating Value		3.6 W
Hot Swapping		Terminal block: Not permitted Communication connector: Permitted

(2) Performance Specifications

The hardware specifications of the Counter Module are shown below.

Item	Specifications
Pulse Counter Specifications	There are 7 different types of pulse input systems: <ul style="list-style-type: none"> • Sign+pulse, 1X • Sign+pulse, 2X • A-and B-phase pulses, 1X • A-and B-phase pulses, 2X • A-and B-phase pulses, 4X • Addition and subtraction pulses, 1X • Addition and subtraction pulses, 2X Using the control program, set the initial setting of the pulse input method as the 'pulse input mode'.
	Maximum Count Speed <ul style="list-style-type: none"> • 1X: 300 Kpps • 2X: 600 Kpps • 4X: 1200 Kpps
	Pulse Input Voltage <p>Use any of the following pulse input voltages: 3, 5, 12, and 24 VDC. The connection methods of the cable to field wiring terminals differ according to the pulse input voltage.</p>
	Pulse Transfer Circuit <p>Use any of the following pulse types: open-collector output, TTL output, and differential voltage output. For an open-collector output, external power (5/12/24 VDC, 10 mA) must be supplied.</p>
	Internal Control Signal <p>The following signals can be output to the High-speed Counter Module from the control program.</p> <ul style="list-style-type: none"> • Count enables: The High-speed Counter Module can count pulses while this signal are ON. • Current value reset: Turning ON this signal can reset the current value of the High-speed Counter Module.
	External Control Signal <p>The following signals can be input to the High-speed Counter Module from limit switches or other external devices:</p> <ul style="list-style-type: none"> • External current value reset: Turning ON this signal can reset the current value of the High-speed Counter Module. • External latch: Turning ON this signal can hold the current value of the High-speed Counter Module. • Input circuit specifications: 24 VDC, photocoupler insulation, 5.0 mA
	Number of Output Signals <p>Notch signal points can be output to external devices such as relays.</p>
	Notch Output Mode <p>Set the initial setting of the output mode of each notch signal either to state mode or latch mode from the control program. The notch signals set in state mode will be ON if the current value of counter is within the range of set notch point. The notch signals set in latch mode will turn ON when the current value of counter reaches the set notch point. To turn these signals OFF, turn the latch reset signal ON from the control program.</p>

(cont'd)

Item		Specifications
Notch Signal Output	Notch Point Set Value	Make the initial notch point settings from the control program. The notch point setting determines the ON/OFF timing of the notch signal. State mode: Two notch point set values (range) Latch mode: One notch point set value (1 point)
	Forced Output Function	Each notch signal can be forced ON or OFF from the control program.
	External Output Circuit	Specifications of the output circuit of each notch signal: Open-collector output, 24 VDC, 100 mA
	Internal Control Signals	The following signals can be output to the Counter Module from the control program. <ul style="list-style-type: none"> • Notch Output Enable: The Counter Module can output notch signals while this signal is ON. • Notch Reset: The notch signals that were turned ON in latch mode can be turned OFF by turning this signal ON.
Monitor Functions	The following signals can be monitored from the control program. <p>READY: ON when the Counter Module is operating normally.</p> <p>ACK: ON when the Counter Module settings have been made successfully.</p> <p>ERROR: ON when a setting error has occurred.</p> <p>NOTCH OUTPUT: ON when the notch output is ON.</p> <p>LATCH INPUT: ON when external latch signal is ON.</p> <p>CARRY: ON for one scan when the pulse count has been incremented to the maximum count value and has rolled over to 0.</p> <p>BORROW: ON for one scan when the pulse count has been decremented to 0 and has rolled over to the maximum count value.</p>	

(3) Pulse Timing and Counting

The following table shows the timing of input pulses and resulting incrementing or decrementing of the pulse count. The pulse count is incremented or decremented at the arrows (h or i).

Input Mode	Incrementing	Decrementing	Counting Speed
Sign and pulse, $\times 1$ multiplication			300 kpps
Sign and pulse, $\times 2$ multiplication			600 kpps
Phase-A and phase-B, $\times 1$ multiplication			300 kpps
Phase-A and phase-B, $\times 2$ multiplication			600 kpps
Phase-A and phase-B, $\times 4$ multiplication			1,200 kpps
Incrementing and decrementing, $\times 1$ multiplication			300 kpps
Incrementing and decrementing, $\times 2$ multiplication			600 kpps

(4) Pulse Waveform

(a) Pulse Waveform

1. Phase A and Phase B Method

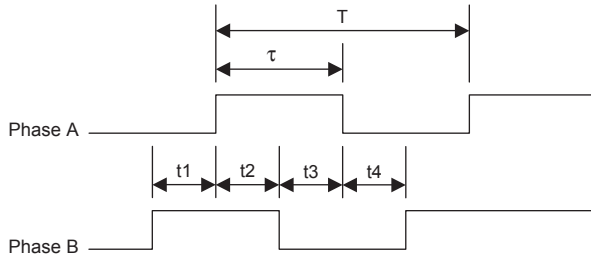

Cycle: $T \geq 3.3 \mu\text{s}$
 Duty factor: $\tau/T \geq 40$ to 60%
 $t_1, t_2, t_3,$ and $t_4 \geq 0.66 \mu\text{s}$

2. Sign and Pulse Method

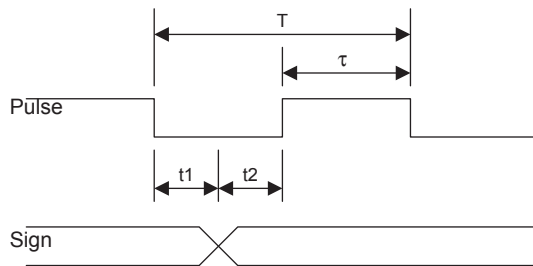

Cycle: $T \geq 3.3 \mu\text{s}$
 Pulse width: $\tau \geq 1.33 \mu\text{s}$
 t_1 and $t_2 \geq 0.66 \mu\text{s}$

3. Increment and Decrement Method

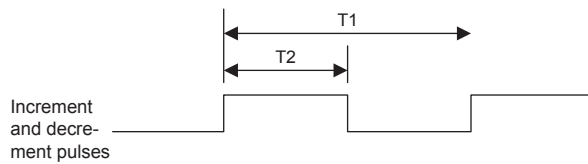

Cycle: $T_1 \geq 3.3 \mu\text{s}$
 Pulse width: $T_2 \geq 1.33 \mu\text{s}$

(b) Input Pulse Waveform

The pulse counting speed is affected by the pulse rise time and the pulse fall time. The following diagram shows the maximum allowable rise and fall times

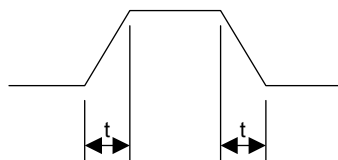

At 200 kpps: $t < 0.2 \mu\text{s}$
 At 50 kpps: $t < 0.8 \mu\text{s}$
 At 5 kpps: $t < 8 \mu\text{s}$

(5) External Input Signal Specifications

(a) Phase-A and Phase-B Pulses

1. Performance Specifications

The performance specifications of the external I/O circuit (phase A and phase B) are shown below.

Item		Specifications (Phase-A and Phase-B Pulses)				
		Voltage	3 VDC* ¹	5 VDC	12 VDC	24 VDC
Rated Voltage			3 VDC	5 VDC	12 VDC	24 VDC
Maximum Allowable Voltage			3.5 VDC	5.5 VDC	13.2 VDC	26.4 VDC
Input Format		Sinking or sourcing				
Rated Current		8 mA				
Input Impedance		180 Ω	430 Ω* ²	1.3 kΩ* ³	2.7 kΩ	
Standard Operating Range	Min. ON Voltage	3.0 VDC	4.5 VDC	10.2 VDC	20.4 VDC	
	Max. OFF Voltage	1.0 VDC	1.5 VDC	1.5 VDC	2.0 VDC	
Input Delay Times	OFF to ON	0.3 μs max.				
	ON to OFF	0.3 μs max.				
External Power Supply (for Signals)		3 VDC	5 VDC	12 VDC	24 VDC	
Input Signal Indicators	PHA	Lit when phase-A pulse is ON (internal logic).				
	PHB	Lit when phase-B pulse is ON (internal logic).				
Isolation Method		Photocoupler				
External Connections		Removable terminal block with M3 screw terminals				

* 1. Connection to differential outputs is possible.

* 2. Combined resistance when a resistance of 330 Ω is connected externally.

* 3. Combined resistance when a resistance of 2.2 kΩ is connected externally.



The terminal connections must be selected based on the voltage level of the input pulse signals. The specifications in the table above apply when the proper connection has been made for the voltage level.

2. Circuit Configuration

The following table shows the circuit configuration for the Counter Module.

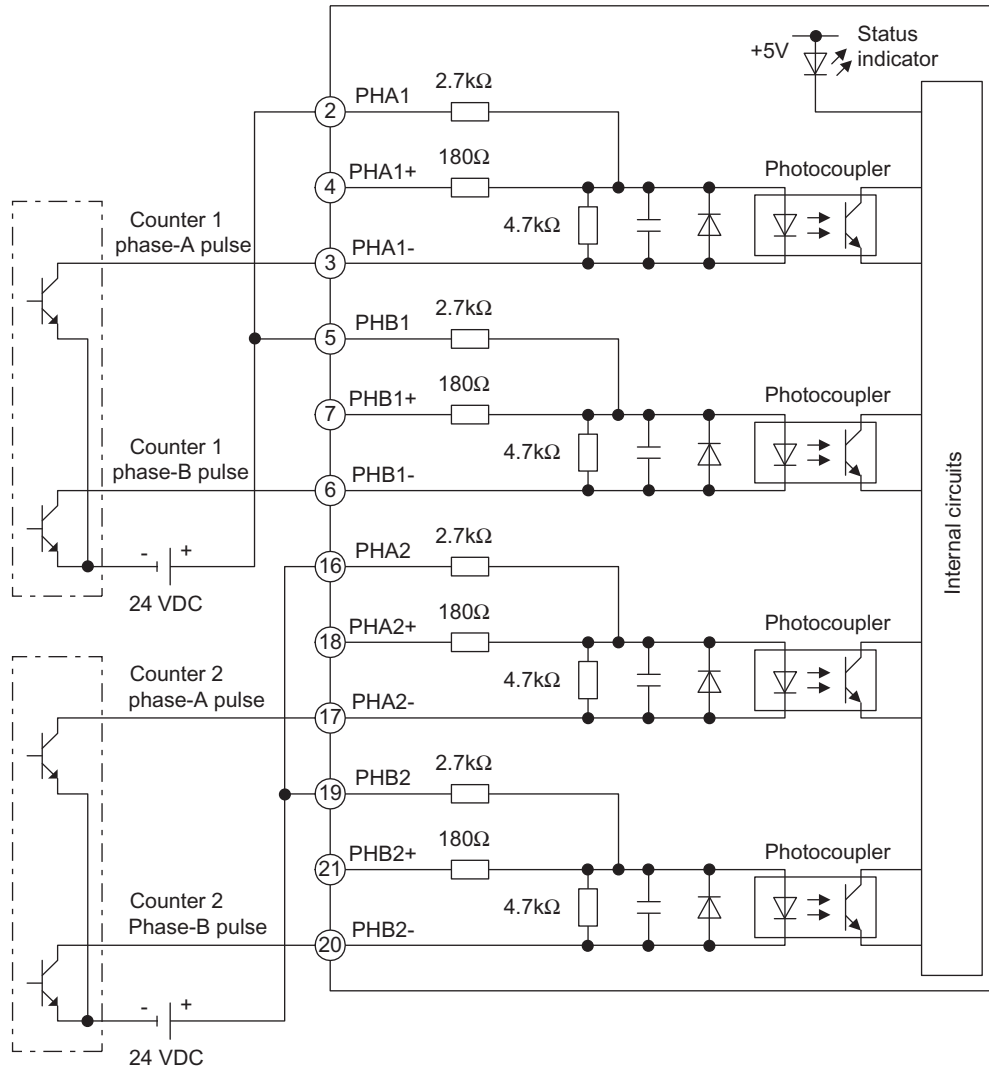

3. Connecting Input Pulse Signal

The terminal connections must be selected based on the voltage level of the input pulse signals. The following diagram shows the proper connection for each voltage level

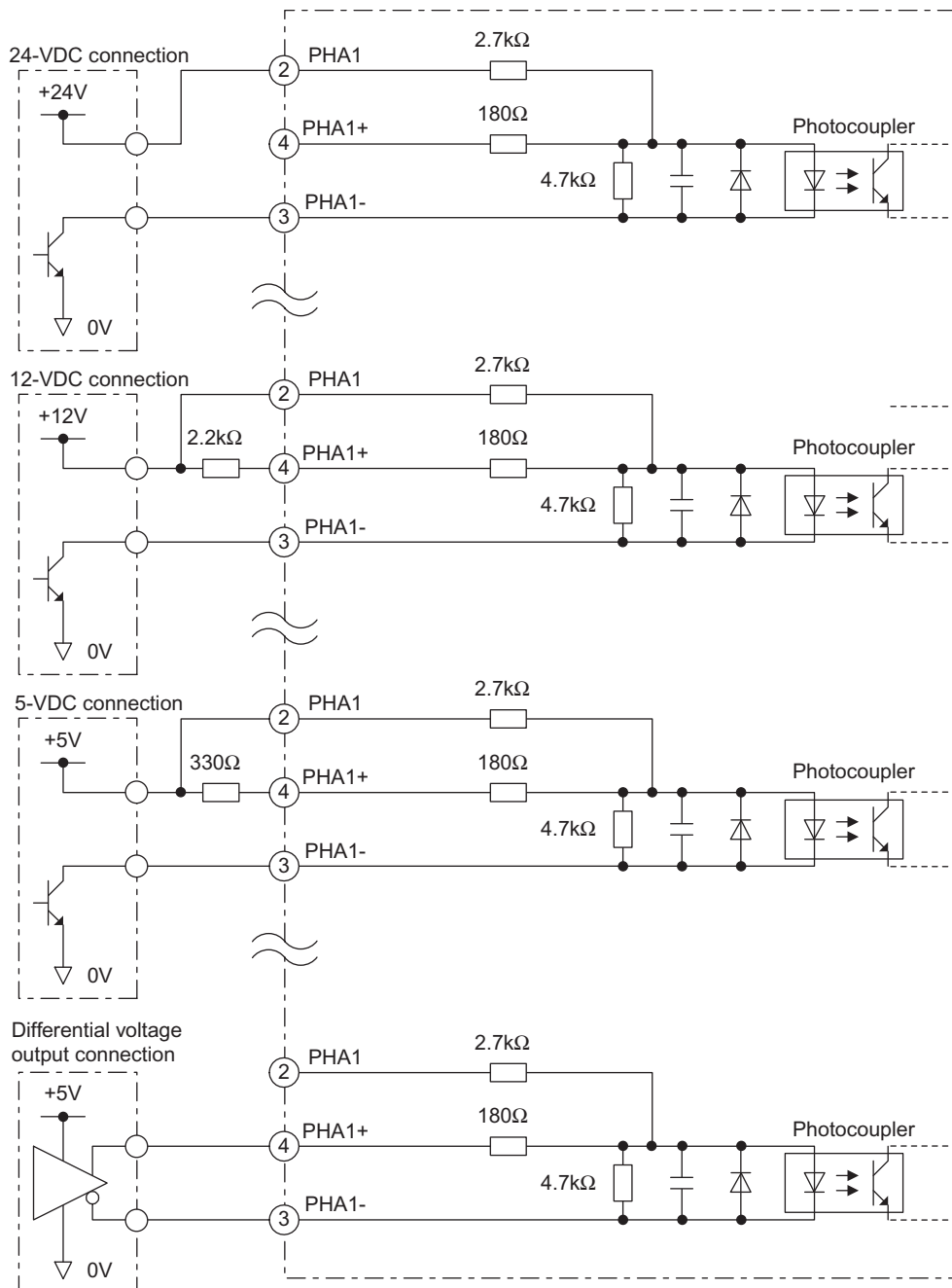

(b) External Latch and External Current Value Reset

1. Performance Specifications

The performance specifications of the external input circuits (external latch and external current value reset) are shown below.

Item		Specifications
Rated Voltage		24 VDC
Maximum Allowable Voltage		24 to 26.4 VDC
Input Format		Sinking or sourcing
Rated Current		5 mA/point
Input Impedance		4.7 kΩ
Standard Operating Range	Min. ON Voltage	10.2 VDC
	Max. OFF Voltage	3.0 VDC
Input Delay Times	External Latch	OFF to ON: 1 ms max. ON to OFF: 2 ms max.
	External Current Value Reset	OFF to ON: 2 ms max. ON to OFF: 2 ms max.
External Power Supply (for Signals)		24 VDC
Input Signal Indicators	RSTn	Lit when external current value reset is ON.
	Ln	Lit when external latch is ON.
Isolation Method		Photocoupler
External Connections		Removable terminal block with M3 screw terminals

2. Circuit Configuration

The following table shows the circuit configuration for the Counter Module.

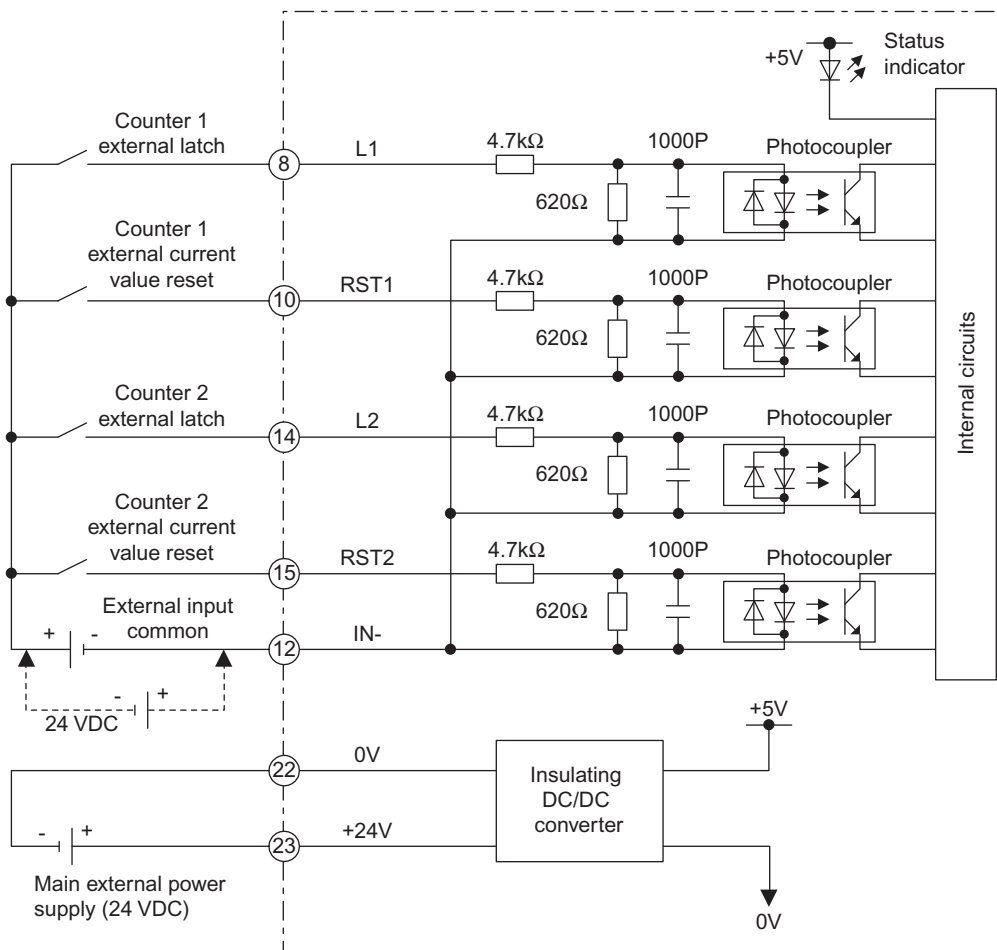

(6) External Output Signal Specifications

(a) Performance Specifications

The performance specifications of the external I/O circuit (external notch output) are shown below.

Item	Specifications
Rated Voltage	24 VDC
Allowable Voltage Range	19.2 to 30.0 VDC
Output Format	Sinking
Maximum Load Current	100 mA/point
Output Voltage Drop	1.5 V max. (100 mA)
Output Delay Times	OFF to ON: 1.5 ms max. ON to OFF: 1.5 ms max.
Leakage Current when OFF	1 mA max. (24 VDC)
Output Type	Transistor output
Number of Commons	1
Output Points per Common	2 points per common
External Connections	Removable terminal block with M3 terminal screws
Output Protection	Unprotected outputs according to JIS B 3501
Built-in Fuse	None
Surge Suppression Circuit	None
Other Output Protection	None
Output Points	Notch outputs: 2
Output Signal Indicators	Indicator lit when each notch point is ON (internal logic).
Isolation Method	Photocoupler
Derating Conditions	None
External Power Supply	For driving loads: 24 VDC

(b) Circuit Configuration

⚠ CAUTION

- Connect a fuse which is appropriate for the load specifications in series with the load.
The output circuit is not equipped with a built-in fuse. Failure to connect a fuse may result in fire, damage to equipment, or damage to the output circuits if there is a load short-circuit or overload.

The following diagram shows the circuit configuration.

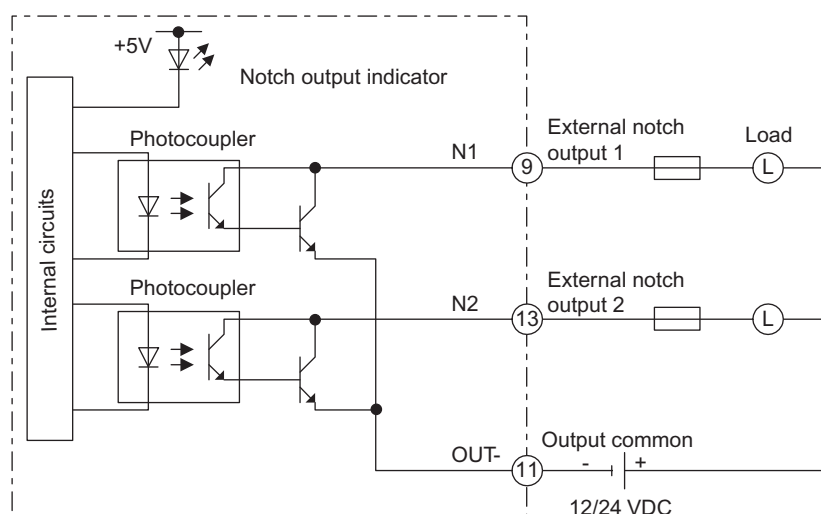

5.5 External I/O Signals and Connection Examples

5.5.1 Overview

The following table summarizes the external I/O signals.

Signal Name		Details
Input Signals	PHAn PHBn	<ul style="list-style-type: none"> Pulses input to the phase-A and phase-B terminals will be counted as the counter's current value. Select the proper connection method based on the signal voltage level being used. Use one of the three counting methods listed below: <ul style="list-style-type: none"> Phase-A and phase-B pulses The phase-A and phase-B pulse counting method supports $\times 1$, $\times 2$, and $\times 4$ multiplication pulse counting. Sign and pulse Input the sign signal to phase-B and the pulses to phase-A. This method supports $\times 1$ and $\times 2$ multiplication pulse counting. Increment and decrement pulses Input the increment pulses to phase-A and the decrement pulses to phase-B. This method supports $\times 1$ and $\times 2$ multiplication pulse counting. <p>This setting is enabled when the Module is initialized.</p>
	RSTn (External current value reset)	<ul style="list-style-type: none"> Sets the counter current value to 0. Effective when the signal goes from OFF to ON. Performs the same function as that perform when the Present Value Reset Output Coil changes from OFF to ON.
	Ln (External latch)	<ul style="list-style-type: none"> Stores the current counter value. Effective when the signal goes from OFF to ON. You can monitor the latch data by selecting the external latch data monitor.
Output Signals	Nn (Notch output)	Outputs are based on comparisons between the notch point setting value(s) and the counter's current value. When the Forced Notch Output n output coil is ON, it forces ON the Notch Output n regardless of other conditions.

Note: The letter "n" at the end of the signals donates counter number 1 or 2.

5.5.2 Connection Examples of External I/O Terminals

(1) Connection Examples of Phase-A and Phase-B Pulses

⚠ CAUTION
<ul style="list-style-type: none"> When the external input pulse signal is 24 VDC, do not connect anything to "PHAn+" or "PHBn+" terminal. There is a risk of input circuit damage.

(a) When pulse generator is open-collector output (24-VDC connection)

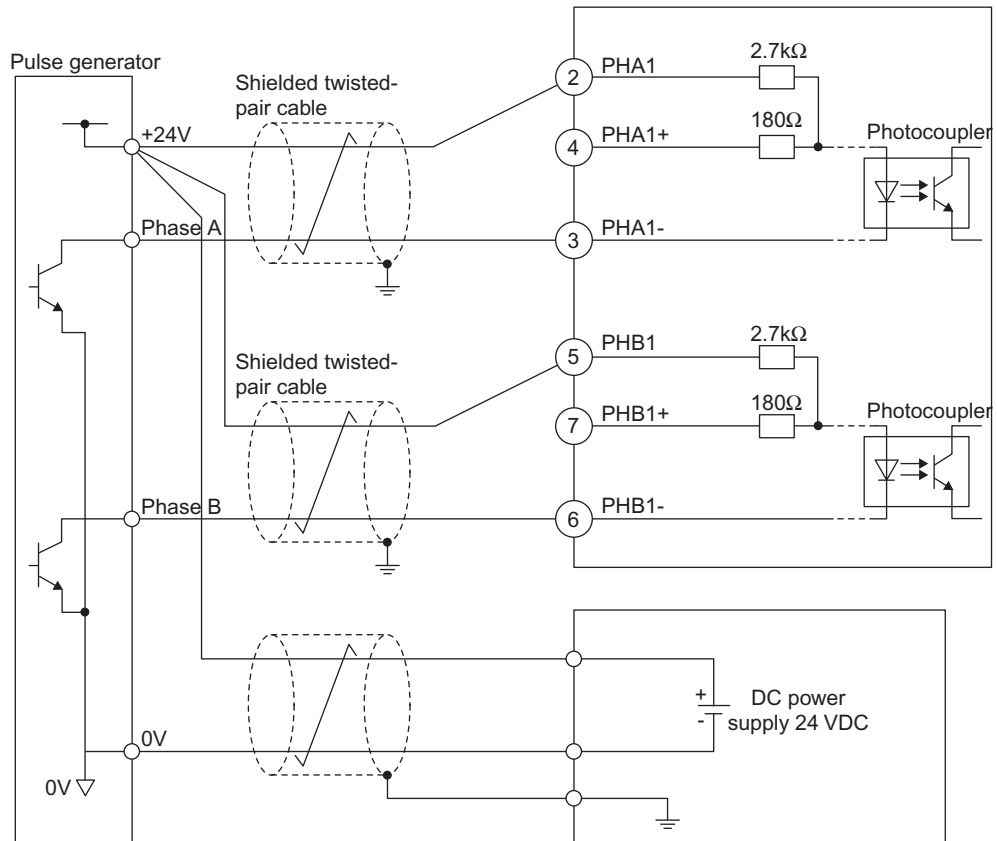

Fig 5.1 Connection Example of Phase-A and Phase-B Pulses ①

IMPORTANT

- Use crimp terminals that fit M3 screw for terminal block wiring.
- Use the shielded twisted-pair cable for the cable for terminal block wiring.
- Do not connect anything to unused input terminals.

⚠ CAUTION

- When the external input pulse signal is 12 VDC, connect a resistor of 22 k Ω (1/4w) between "PHAn" and "PHA+" terminals and between "PHBn" and "PHB+" terminals.
There is a risk of input circuit damage.

(b) When pulse generator is open-collector output (12-VDC connection)

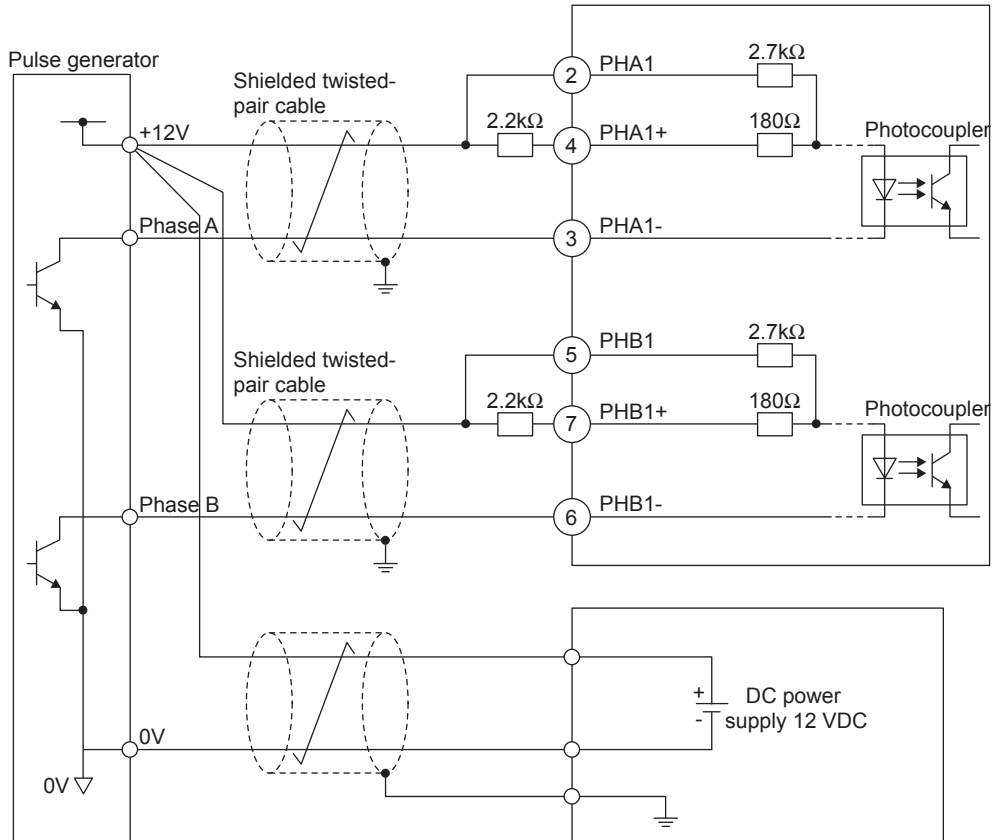

Fig 5.2 Connection Example of Phase-A and Phase-B Pulses ②

IMPORTANT

- Use crimp terminals that fit M3 screw for terminal block wiring.
- Use the shielded twisted-pair cable for the cable for terminal block wiring.
- Do not connect anything to unused input terminals.

⚠ CAUTION

- When the external input pulse signal is 5 VDC, connect a resistor of 330Ω (1/4w) between “PHA_n” and “PHA+” terminals and between “PHB_n” and “PHB+” terminals.

There is a risk of input circuit damage.

(c) When pulse generator is sourcing-voltage output (5-VDC connection)

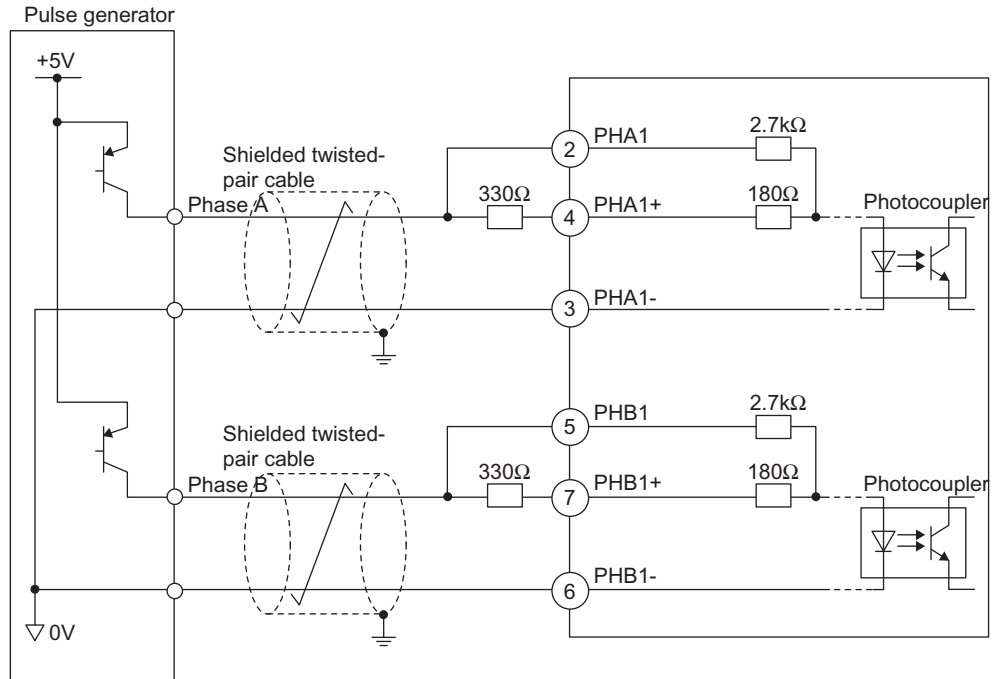

Fig 5.3 Connection Example of Phase-A and Phase-B Pulses ③

IMPORTANT

- Use crimp terminals that fit M3 screw for terminal block wiring.
- Use the shielded twisted-pair cable for the cable for terminal block wiring.
- Do not connect anything to unused input terminals.

⚠ CAUTION

- When the external input pulse signal is of differential output voltage, do not connect anything to “PHAn” and “PHBn” terminals.
 There is a risk of input circuit damage.

(d) When pulse generator is differential voltage output

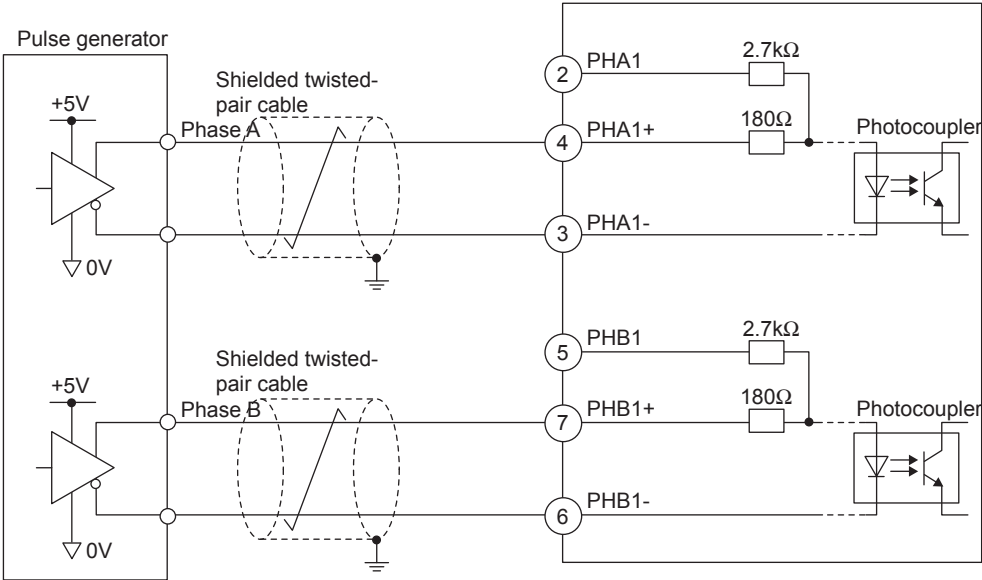

Fig 5.4 Connection Example of Phase-A and Phase-B Pulses ④

IMPORTANT

1. Use crimp terminals that fit M3 screw for terminal block wiring.
2. Use the shielded twisted-pair cable for the cable for terminal block wiring.
3. Do not connect anything to unused input terminals.

(2) Connection Examples of External Latch and External Current Value Reset Functions
 (a) When external devices are open-collector output (24-VDC connection)

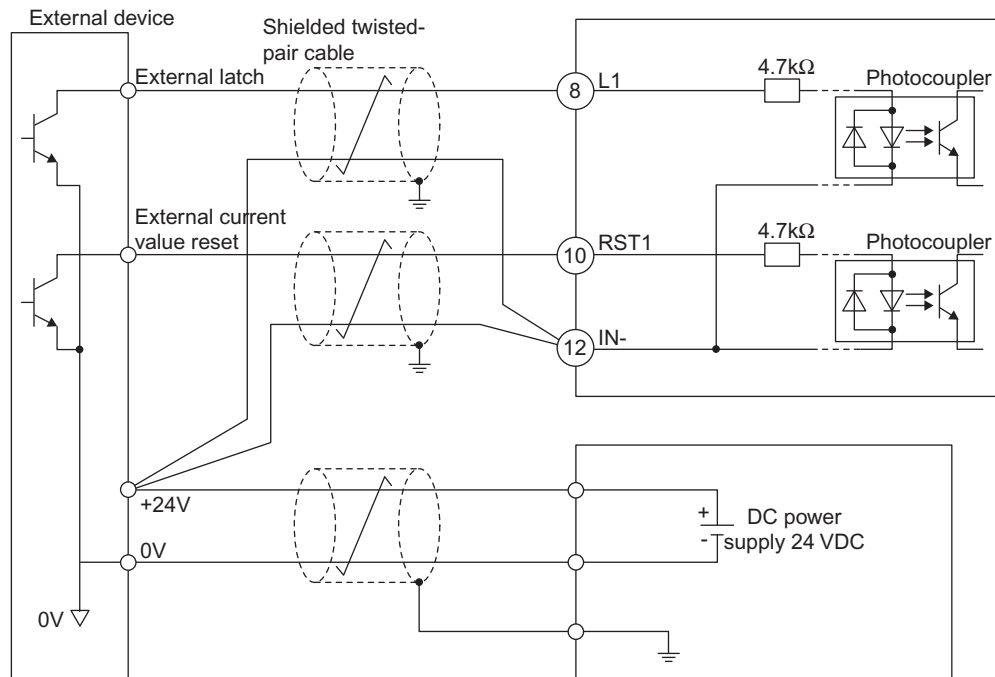

Fig 5.5 Connection Example of External Latch and External Current Value Reset Functions ①

IMPORTANT

1. Use crimp terminals that fit M3 screw for terminal block wiring.
2. Use the shielded twisted-pair cable for the cable for terminal block wiring.
3. Do not connect anything to unused input terminals.

(b) When counter current value reset functions by external signal and external latch function are not used

- When the external latch function is not used, connect terminal “Ln” to terminal “IN-.”
- When the external current value reset function is not used, connect terminal “RSTn” to terminal “IN-.”

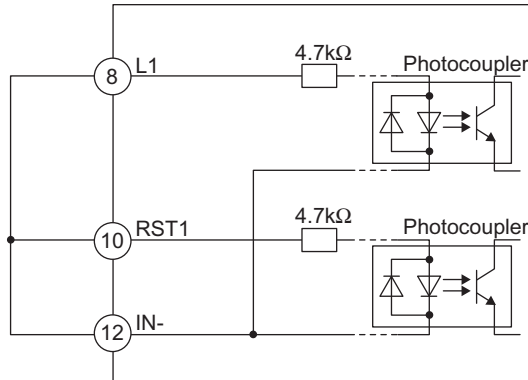

Fig 5.6 Connection Example of External Latch and External Current Value Reset Functions ②

IMPORTANT

1. Use crimp terminals that fits M3 screws for terminal block wiring.
2. Use wire with the following gauge when connecting wire to the terminal block.
24 AWG (0.2 mm²) to 18 (0.9 mm²)
3. The polarity of the external signal power supply can be connected in either direction.

(3) Connection Example of Notch Output

⚠ CAUTION

- Connect a fuse appropriate for the load specifications in series with the load. The output circuit is not equipped with a built-in fuse.
There is a risk of fire, damage to the load equipment, or damage to the output circuits if there is a load short-circuit or overload.
- To connect an induction load, connect the fly-wheel diode in parallel to the induction load to reduce surge voltage.
There is a risk of output circuit damage.

- When external devices are induction loads (24-VDC connection)

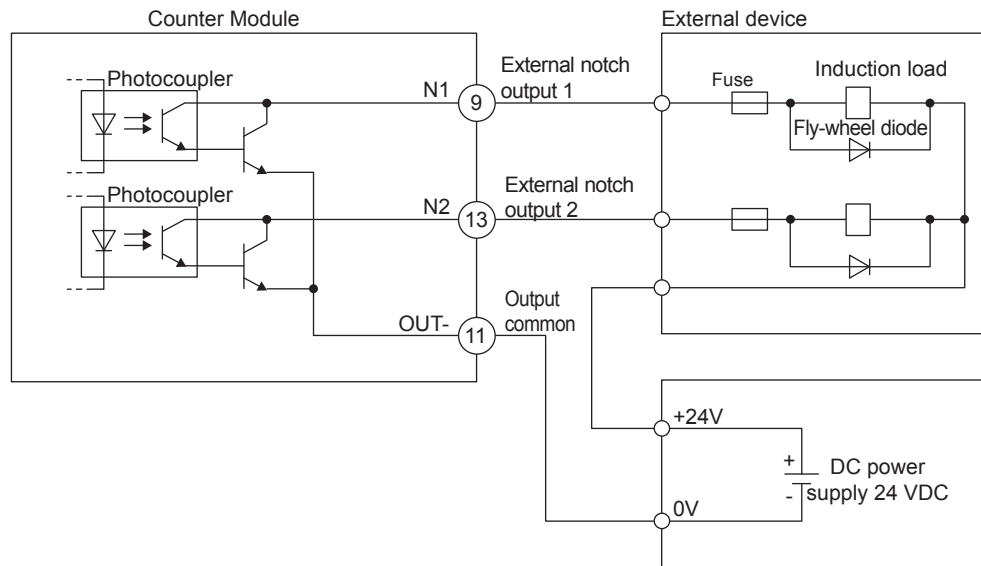

Fig 5.7 Connection Example of Notch Output

IMPORTANT

1. Use crimp terminals that fits M3 screws for terminal block wiring.
2. Use wire with the following gauge when connecting wire to the terminal block.
24 AWG (0.2 mm²) to 18 (0.8 mm²)
3. Do not connect anything to unused input terminals.

5.5.3 I/O Allocations

This section explains the Counter Module's I/O allocations.

For details, refer to *Machine Controller MP900/MP2000 Series MPE720 Software for Programming Device User's Manual* (SIEPC88070005).

(1) Purpose of I/O Allocations

The correspondence between the Counter Module's internal signals and I/O registers must be defined in order for the Counter Module to input signals from input devices and the CPU Module or output signals to output devices and the CPU Module. Set the I/O register numbers to define this correspondence for the Counter Modules.

Allocate I/O with a Programming Device (MPE720). The results of the allocation are stored in the CPU Module's memory as an I/O allocation table.

(2) I/O Allocation Settings

(a) Setting the Leading and End I/O Register Numbers

The range of consecutive I/O register numbers allocated to the MECHATROLINK Master Module are set in the Module configuration definitions window.

◀ EXAMPLE ▶

In the example Module definitions window shown below, the I/O register range for an MP920 SVB-01 has been set to 0100 to 017F. The I/O registers allocated to the Counter Module are set within this range.

Rack 1				
No.	00	00	00	
Module	MP920 ▼		SVB-01 ▼	
Control CPU No.				
I/O Start Register			0100	
I/O End Register			017F	

(b) Transmission Cycle Settings

Set the MECHATROLINK transmission cycle in the **Transmission Parameters** Tab of the MECHATROLINK definitions window. Use the initial setting if there is no particular need to change the setting.

Transmission Parameters	
Master/Slave	Master ▼
Own Station Address	0 ▲▼
Message Trust Level	0 ▼
Max. Slave ST Number	14 ST: 4 Mbps, 2 ms ▼

(c) Allocation of I/O Register Numbers

Set the Counter Module's leading I/O register number in the **I/O Allocations** Tab of the MECHATROLINK definitions window.

I/O Allocations								
ST#	TYPE	D	INPUT	SIDE	D	OUTPUT	SIDE	SCAN
01		<input type="checkbox"/>			<input type="checkbox"/>			
02		<input type="checkbox"/>			<input type="checkbox"/>			

(3) I/O Allocations

Set the following items in the **I/O Assignment** Tab.

Item	Contents
ST#	Allocate station numbers to the devices connected to the MECHATROLINK network. Set station numbers in order beginning at 01.
TYPE	Set the model of MECHATROLINK Module connected at each station. Open the pull-down menu in the TYPE field and select 120EHC21140/PL2900. <div style="border: 1px solid black; padding: 5px; width: fit-content; margin: 5px 0;"> <p style="text-align: center; margin: 0;">TYPE</p> <div style="border-bottom: 1px solid black; padding: 2px 5px; display: flex; justify-content: space-between;"> 120EHC21140 ▼ </div> </div>
D	This field enables or disables inputs. Click the box to display a check-mark and disable inputs. Click the box again to remove the check-mark and enable inputs.
INPUT SIZE	Set the leading input register number (IWxxxx). The number of registers in the SIZE field is set to 7 automatically.
D	This field enables or disables outputs. Click the box to display a check-mark and disable outputs. Click the box again to remove the check-mark and enable outputs.
OUTPUT SIZE	Set the leading output register number (OWxxxx). The number of registers in the SIZE field is set to 8 automatically.
SCAN	Adjusts I/O timing. <ul style="list-style-type: none"> • Select "High" for high-speed scan. • Select "Low" for low-speed scan.

5.5.4 Output Coils

An output coil is a control signal sent from the host controller to the Counter Module. The following table lists the output coils.

Address	Counter Number	Bit 7	Bit 6	Bit 5	Bit 4	Bit 3	Bit 2	Bit 1	Bit 0	
OWxxxx +2	1	Lower-place byte	L-RES1	N-RES1	PRES-1	N-ENB1	C-ENB1	P-SET1	N-SET1	M-SET1
		Upper-place byte	L-RES2	N-RES2	PRES-2	N-ENB2	C-ENB2	P-SET2	N-SET2	M-SET2
OWxxxx +3	2	Lower-place byte	–	–	–	–	–	–	N-ON2	N-ON1
		Upper-place byte	–	–	–	–	–	MON3	MON2	MON1

Byte	Bit No.	Symbol	Signal Name	Details
Lower-place byte (n=1) Upper-place byte (n=2)	0	M-SETn	Mode Set	This is the counter mode setting reference. The following settings are made: <ul style="list-style-type: none"> • Pulse count mode • Notch output mode • Notch input polarity
	1	N-SETn	Notch Point Set	This is the notch point set value preset reference. Write the notch point setting in the corresponding output register in advance. The notch point is set when this signal goes from OFF to ON.
	2	P-SETn	Current Value Set	This is the Counter's current value preset reference. Write the current value setting in the corresponding output register in advance. The current value is set when this signal goes from OFF to ON.
	3	C-ENBn	Count Enable	Input pulses can be counted when the Count Enable signal is ON. This signal is effective when it is ON.
	4	N-ENBn	Notch Output Enable	When the Notch Output Enable signal is ON, output of the external Notch Output is enabled. This signal is effective when it is ON. Outputs can be made using the Forced Outputs 0 to 3 signals even when the Notch Output Enable signal is OFF.
	5	P-RESn	Current Value Reset	Resets the Counter's current value to 0. The current value is reset to 0 when this signal goes from OFF to ON.
	6	N-RESn	Notch Output Reset	Resets the latch status of the notch output that specified the latch mode. The notch output is reset when this signal goes from OFF to ON.
	7	L-RESn	Count Value Hold Reset	Resets the external latch input status. The external latch is reset when this signal goes from OFF to ON.
Lower-place byte	0 (n=1) 1 (n=2)	N-ONn	Forced Notch Output	The Notch Output n is turned ON when the Forced Notch Output n is ON, regardless of other conditions. This signal is effective when it is ON.
Upper-place byte	0	MON1	Monitor 1	The status of MON1, MON2, and MON3 determines which data is monitored. Refer to the following table.
	1	MON2	Monitor 2	
	2	MON3	Monitor 3	

Note: The letter "n" at the end of the signal denotes counter number 1 or 2.

* The following table shows which data is monitored for each combination of MON1, MON2, and MON3.

Output Coil Status			Monitored Data
MON3	MON2	MON1	
OFF	OFF	OFF	Counter current value
OFF	OFF	ON	External latch data
OFF	ON	OFF	Status
OFF	ON	ON	Counter mode
ON	OFF	OFF	(For system use)
ON	OFF	ON	Counter 1 notch point set value
ON	ON	OFF	Counter 2 notch point set value
ON	ON	ON	Current value set value

5.5.5 Output Registers

Output registers are used together with output coils when setting numeric values from the host controller to the Counter Module.

Output registers are used to make the following settings:

- Counter Mode Settings
- Notch Point Settings
- Current Value Setting

IMPORTANT	The same output registers are used to set different data at different times, so be careful that the setting signals do not overlap.
------------------	---

The following table lists the output registers.

Register Address	Output Register No.	Setting		
		Mode Set	Notch Point Set	Current Value Set
OWxxxxx+4	1st byte	Mode setting	Notch point Pm (lower bytes)	Current value set value (counter 1)
	2nd byte	For system use (always 0)		
OWxxxxx+5	3rd byte	For system use (always 0)	Notch point Pm (upper bytes)	
	4th byte	For system use (always 0)		
OWxxxxx+6	5th byte	Mode setting	Notch point Pm' (lower bytes)	Current value set value (counter 2)
	6th byte	For system use (always 0)		
OWxxxxx+7	7th byte	For system use (always 0)	Notch point Pm' (upper bytes)	
	8th byte	For system use (always 0)		

Note: 1. The mode setting for counter 1 is in the 1st byte and the mode setting for counter 2 is in the 5th byte.
 2. Notch point settings and current value settings are shared by Counters 1 and 2 and can be set at the same time.

5.5.6 Input Relays

Input relays are status signals sent from the Counter Module to the host controller.

The following table lists the input relays.

Address	Counter No.	Bit 7	Bit 6	Bit 5	Bit 4	Bit 3	Bit 2	Bit 1	Bit 0
IWxxx+2	1	Lower byte					ERR	ACK	RDY
		Upper byte	L2	N2	BORW2	CARY2	L1	N1	BDRW1

Byte	Bit No.	Symbol	Signal Name	Details
Lower byte	0	RDY	Ready	Indicates the results of the Module's self-diagnostic tests. Normal: ON Abnormal: OFF
	1	ACK	Settings normal	When the reference is set to OFF, both the ACK and the ERR signals turn OFF. When the set operation is normal, only the ACK signal turns ON.
	2	ERR	Error	When the reference is set to OFF, both the ACK and the ERR signals turn OFF. When the set operation is faulty, only the ERR signal turns ON.
Upper byte	0 (n=1) 4 (n=2)	CARYn	Carry	This signal stays ON for one scan only when the Counter's current value is incremented past the counter upper limit value and rolls over to 0.
	1 (n=1) 5 (n=2)	BORWn	Borrow	This signal stays ON for one scan only when the Counter's current value is decremented past 0 and rolls over to the counter upper limit value.
	2 (n=1) 6 (n=2)	Nn	Notch output status	Indicates the status of the external notch output. The notch output signal goes ON when the external notch output signal goes ON.
	3 (n=1) 7 (n=2)	Ln	Latch input status	Indicates that the external latch signal has been input. The latch input signal goes ON when the external latch input signal goes ON.

Note: The letter "n" at the end of the signal denotes counter number 1 or 2.

5.5.7 Input Registers

Input registers are used when monitoring various kinds of information in the Counter Module.

Input registers are used for monitoring the following information:

- Mode Settings
- Notch Point Settings
- Current Value Setting
- Current Value
- Latch Data
- Status

IMPORTANT

The same input registers are used to monitor different data at different times, so be careful that the monitor signals do not overlap.

The input registers are listed in the following tables.

(a) Monitoring Status

Register Address	Monitored Data		
	Current Value Monitor	Latch Data Monitor	Status Monitor
IWxxxxx+3	Counter 1 current value lower bytes	Counter 1 latch data lower bytes	For system
IWxxxxx+4	Counter 1 current value upper bytes	Counter 1 latch data upper bytes	For system
IWxxxxx+5	Counter 2 current value lower bytes	Counter 2 latch data lower bytes	For system
IWxxxxx+6	Counter 2 current value upper bytes	Counter 2 latch data upper bytes	For system

(b) Monitoring Set Values

Register Address	Monitored Data			
	Mode Settings Monitor	Notch Point Monitor	Notch Point Monitor	Current Value Setting Monitor
IWxxxxx+3	Counter 1 mode	Counter 1 notch point n (lower bytes)	Counter 2 notch point n (lower bytes)	Counter 1 current value set value (lower bytes)
IWxxxxx+4	For system	Counter 1 notch point n (upper bytes)	Counter 2 notch point n (upper bytes)	Counter 1 current value set value (upper bytes)
IWxxxxx+5	Counter 2 mode	Counter 1 notch point n' (lower bytes)	Counter 2 notch point n' (lower bytes)	Counter 2 current value set value (lower bytes)
IWxxxxx+6	For system	Counter 1 notch point n' (upper bytes)	Counter 2 notch point n' (upper bytes)	Counter 2 current value set value (upper bytes)

5.5.8 Monitoring Data

(1) Overview

The following seven kinds of data in the Counter Module can be monitored.

- Current value
- External latch data
- Status
- Mode settings
- Counter 1 notch point setting
- Counter 2 notch point setting
- Current set value

Input relays and output coils are used together to monitor data. Eight consecutive bytes of input registers are used to monitor various types of data sent from the Counter Module to the host controller.

(2) Monitoring the Current Value

To monitor the current value, set the MON1, MON2, and MON3 output coils as follows:

- MON1: OFF
- MON2: OFF
- MON3: OFF

The current values for counters 1 and 2 are monitored simultaneously.

Monitored Data	Input Registers		
Current value	1st byte	Current value (lower word, lower byte)	} Counter 1
	2nd byte	Current value (lower word, upper byte)	
	3rd byte	Current value (upper word, lower byte)	
	4th byte	Current value (upper word, upper byte)	
	5th byte	Current value (lower word, lower byte)	} Counter 2
	6th byte	Current value (lower word, upper byte)	
	7th byte	Current value (upper word, lower byte)	
	8th byte	Current value (upper word, upper byte)	

(3) Monitoring the External Latch Data

To monitor the external latch data, set the MON1, MON2, and MON3 output coils as follows:

- MON1: ON
- MON2: OFF
- MON3: OFF

External latch data for counters 1 and 2 is monitored simultaneously.

Monitored Data	Input Registers		
External latch data	1st byte	External latch data (lower word, lower byte)	} Counter 1
	2nd byte	External latch data (lower word, upper byte)	
	3rd byte	External latch data (upper word, lower byte)	
	4th byte	External latch data (upper word, upper byte)	
	5th byte	External latch data (lower word, lower byte)	} Counter 2
	6th byte	External latch data (lower word, upper byte)	
	7th byte	External latch data (upper word, lower byte)	
	8th byte	External latch data (upper word, upper byte)	

(4) Monitoring the Status

To monitor the status, set the MON1, MON2, and MON3 output coils as follows:

- MON1: OFF
- MON2: ON
- MON3: OFF

The status monitor will be used for the system.

The status data for counters 1 and 2 is monitored simultaneously.

Monitored Data	Input Registers			
Status	1st byte	For system	}	Counter 1
	2nd byte	For system		
	3rd byte	For system		
	4th byte	For system		
	5th byte	For system	}	Counter 2
	6th byte	For system		
	7th byte	For system		
	8th byte	For system		

(5) Monitoring the Mode Setting Value

To monitor the mode setting values, set the MON1, MON2, and MON3 output coils as follows:

- MON1: ON
- MON2: ON
- MON3: OFF

The mode setting values for counters 1 and 2 are monitored simultaneously.

Monitored Data	Input Registers			
Mode setting values	1st byte	Mode setting value	}	Counter 1
	2nd byte	For system		
	3rd byte	For system		
	4th byte	For system		
	5th byte	Mode setting value	}	Counter 2
	6th byte	For system		
	7th byte	For system		
	8th byte	For system		

(6) Monitoring the Counter 1 Notch Points

To monitor the counter 1 notch points, set the MON1, MON2, and MON3 output coils as follows:

- MON1: ON
- MON2: OFF
- MON3: ON

Monitored Data	Input Registers	
Counter 1 notch points	1st byte	Notch point Pm (lower word, lower byte)
	2nd byte	Notch point Pm (lower word, upper byte)
	3rd byte	Notch point Pm (upper word, lower byte)
	4th byte	Notch point Pm (upper word, upper byte)
	5th byte	Notch point Pm' (lower word, lower byte)
	6th byte	Notch point Pm' (lower word, upper byte)
	7th byte	Notch point Pm' (upper word, lower byte)
	8th byte	Notch point Pm' (upper word, upper byte)
		} Counter 1

(7) Monitoring the Counter 2 Notch Points

To monitor the counter 2 notch points, set the MON1, MON2, and MON3 output coils as follows:

- MON1: OFF
- MON2: ON
- MON3: ON

Monitored Data	Input Registers	
Counter 2 notch points	1st byte	Notch point Pm (lower word, lower byte)
	2nd byte	Notch point Pm (lower word, upper byte)
	3rd byte	Notch point Pm (upper word, lower byte)
	4th byte	Notch point Pm (upper word, upper byte)
	5th byte	Notch point Pm' (lower word, lower byte)
	6th byte	Notch point Pm' (lower word, upper byte)
	7th byte	Notch point Pm' (upper word, lower byte)
	8th byte	Notch point Pm' (upper word, upper byte)
		} Counter 2

(8) Monitoring the Current Value Set Value

To monitor the current value set value, set the MON1, MON2, and MON3 output coils as follows:

- MON1: OFF
- MON2: OFF
- MON3: OFF

The current value set values for counters 1 and 2 are monitored simultaneously.

Monitored Data	Input Registers			
Current value set values	1st byte	Current value set value (lower word, lower byte)	}	Counter 1
	2nd byte	Current value set value (lower word, upper byte)		
	3rd byte	Current value set value (upper word, lower byte)		
	4th byte	Current value set value (upper word, upper byte)		
	5th byte	Current value set value (lower word, lower byte)	}	Counter 2
	6th byte	Current value set value (lower word, upper byte)		
	7th byte	Current value set value (upper word, lower byte)		
	8th byte	Current value set value (upper word, upper byte)		

(9) Reserved for Future Use

The following MON1, MON2, and MON3 output coils settings are used for the system:

- MON1: OFF
- MON2: OFF
- MON3: ON

Monitored Data	Input Registers			
Reserved	1st byte	For system	}	Counter 1
	2nd byte	For system		
	3rd byte	For system		
	4th byte	For system		
	5th byte	For system	}	Counter 2
	6th byte	For system		
	7th byte	For system		
	8th byte	For system		

5.6 Precautions on Wiring

5.6.1 External Pulse Input Circuit (Phase-A Pulse, Phase-B Pulse)

(1) Connections of External Pulse Input Signal Lines

This paragraph describes the precautions on the connections of the external pulse input signal lines with the following diagram as an example.

In the following example, the pulse generator is open-collector output (12 VDC).

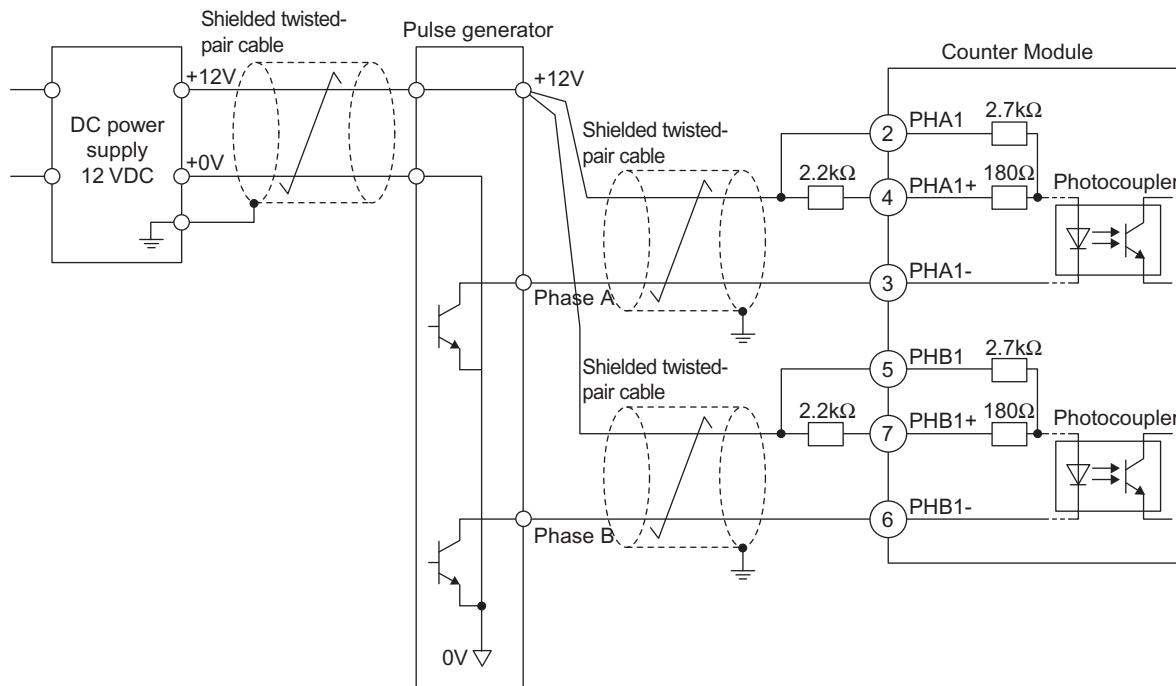

- Be sure to use shielded twisted-pair cables for the external pulse input signal lines. The outer sheath of the shielded cable must be grounded to one point at the Module side. Insufficient grounding may result in malfunction caused by noise influence.
- The wiring distance of the external pulse input signal lines must be as short as possible. Excessively long wiring distance will cause the pulse waveform to lose precision, resulting in malfunction. The input pulse waveform is specified as shown below.

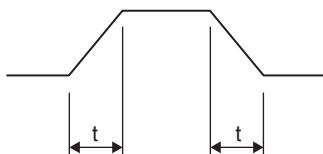

At 300 kpps: $t < 0.2 \mu\text{s}$
 At 75 kpps: $t < 0.8 \mu\text{s}$
 At 7.5 kpps: $t < 8 \mu\text{s}$

- Separate the external pulse input signal line's wiring and laying from the power lines inside and outside of the Control Panel. Make or lay the wiring at least 30 cm from the power lines. Never pass the external pulse input signal line's wiring together with the power lines in the same duct. Insufficient separation may result in malfunction caused by noise influence.
- For some external pulse input circuits, the external wiring terminal connections need to be changed depending on the type of pulse input voltage. Do not connect anything to unused input terminals. Improper connections may result in damage to the external pulse input circuit.

(2) Connections of External Pulse DC Power Supply

This paragraph describes the precautions on the external pulse DC power supply connections with the following diagram as an example.

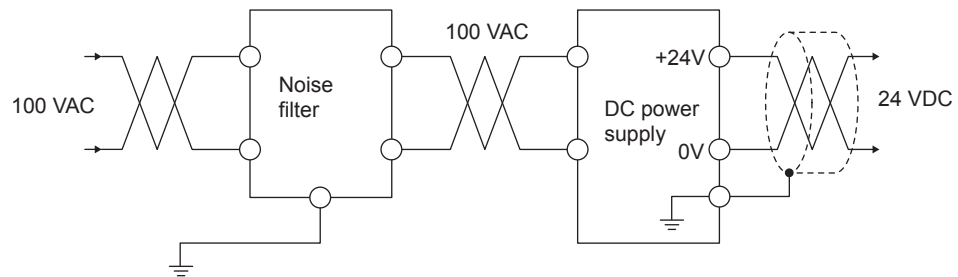

- Avoid common use of the external pulse input signal DC power supply with any other I/O power supply whenever possible.
If it is shared, noise from other devices may affect the power supply, resulting in malfunction.
- If the AC input power supply of the external input signal AC power supply has excessive noise, attach a noise filter at the DC power supply AC input side. Do not pass the noise filter primary side power line together with the secondary side power line or DC power line in the same duct.
Insufficient separation may result in malfunction caused by noise influence.
- Connect the noise filter protective ground terminal (FG) with the Control Panel ground terminal (E) and the cable between AWG (1.5 mm²) and 13 AWG (2.5 mm²).
Improper grounding may result in malfunction caused by noise influence.

5.6.2 External Input Circuit (External Latch and External Current Value Reset Functions)

(1) When Connecting an induction load

To connect an induction load in parallel to the external input circuit as shown below, connect the fly-wheel diode in parallel to the induction load to reduce surge voltage.

Unless any fly-wheel diode is connected, the external input circuit may be damaged.

The type of fly-wheel diode should be changed according to the load specifications; however, the following is recommended for general purposes.

- H14E Series (manufactured by HITACHI) or equivalent

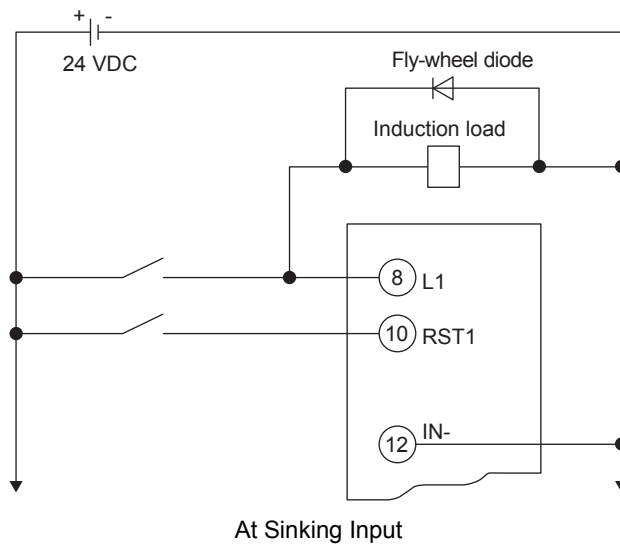
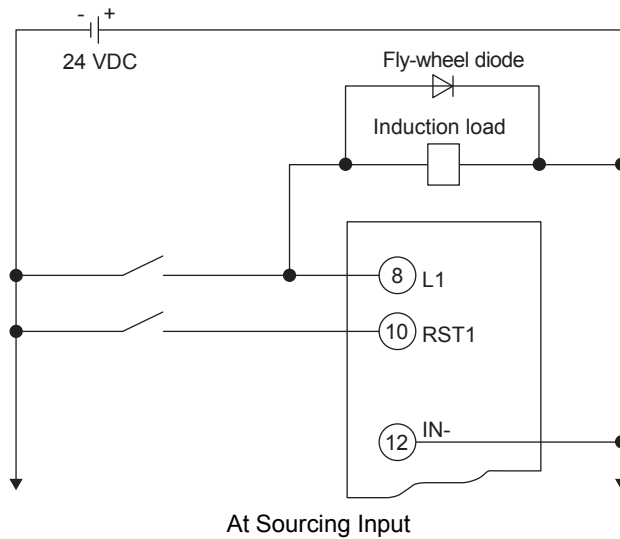

(2) Connections to Input Device with Different Voltage from External Input Circuit

The input device power supply voltage must coincide with the external input circuit power supply voltage in principle. The following shows the examples of input devices having different voltages and whether connection is enabled or disabled.

Example of Input Device	V1 < V2, open-collector output
Connections	Enabled
Example of Input Device	V1 < V2, output with diode
Connections	Enabled
Example of Input Device	V1 < V2, output with resistor and LED
Connections	Disabled Reason: When the input device is turned OFF, the circulating current indicated with the dotted line in the following figure flows and reverse voltage is applied to the LED, resulting in breakage of the LED.

5.6.2 External Input Circuit (External Latch and External Current Value Reset Functions)

<p>Example of Input Device</p>	<p>V1 < V2, open-collector output</p>
<p>Connections</p>	<p>Enabled Output transistor withstand voltage of the input device must be at least 40 V.</p>
<p>V1: Input signal power supply V2: Input device power supply</p> <p>Counter Module</p> <p>IN- (12)</p> <p>RST1 (10)</p> <p>Photocoupler</p> <p>R</p> <p>Input device</p> <p>V1 DC24V</p> <p>V2 DC12V</p>	
<p>Example of input device</p>	<p>V1 < V2, output with diode</p>
<p>Connections</p>	<p>Disabled Reason: When the input device is turned OFF, the circulating current indicated with the dotted line in the following figure flows and reverse voltage is applied to the LED, resulting in breakage of the LED.</p>
<p>V1: Input signal power supply V2: Input device power supply</p> <p>Counter Module</p> <p>IN- (12)</p> <p>RST1 (10)</p> <p>Photocoupler</p> <p>R</p> <p>Input device</p> <p>V1 DC24V</p> <p>V2 DC12V</p>	
<p>Example of input device</p>	<p>V1 < V2, output with resistor and LED</p>
<p>Connections</p>	<p>Disabled Reason: When the input device is turned OFF, the circulating current indicated with the dotted line in the following figure flows and reverse voltage is applied to the LED, resulting in breakage of the LED.</p>
<p>V1: Input signal power supply V2: Input device power supply</p> <p>Counter Module</p> <p>IN- (12)</p> <p>RST1 (10)</p> <p>Photocoupler</p> <p>R</p> <p>Input device</p> <p>V1 24 VDC</p> <p>V2 12 VDC</p>	

5.6.3 External Output Circuit (External Notch Output)

(1) Output Fuse

The external output circuit is not equipped with a built-in fuse. Connect a fuse appropriate for the load specifications in series with the load, to prevent any accident caused by overload or to protect the output elements.

Failure to connect a fuse may result in fire, damage to equipment, or damage to the output circuits if there is a load short-circuit or overload.

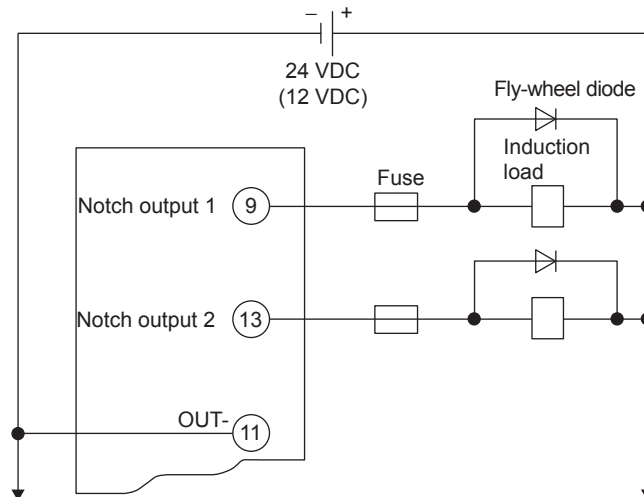

(2) Connection of induction load

When an induction load is connected to the external output circuit as shown below, connect a fly-wheel diode in parallel to the induction load to reduce surge voltage. When an induction load of the external output circuit is connected to the contact, connect the fly-wheel diode in parallel to the induction load to reduce surge voltage. Failure to connect a fly-wheel diode may result in damage to the external output circuit.

The type of the fly-wheel diode must be changed according to the load specifications; however, the following is recommended for general purposes.

- H14E Series (manufactured by HITACHI) or equivalent

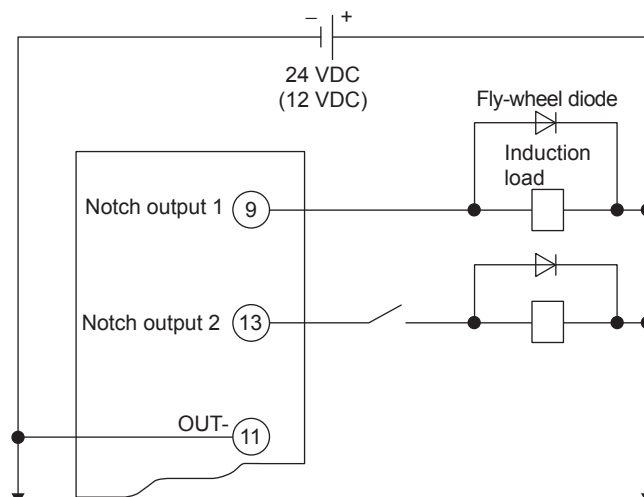

(3) Load with Large Inrush Current

When a load having large inrush current such as incandescent lamps is connected, use the following method to reduce inrush current less than the maximum load current of the external output circuit.

Failure to observe the conditions for the maximum load current may result in damage to the output elements.

- Let dark current of approx. 30% of rated current flow in the incandescent lamp.
- Attach a current limit resistor in series with the incandescent lamp.

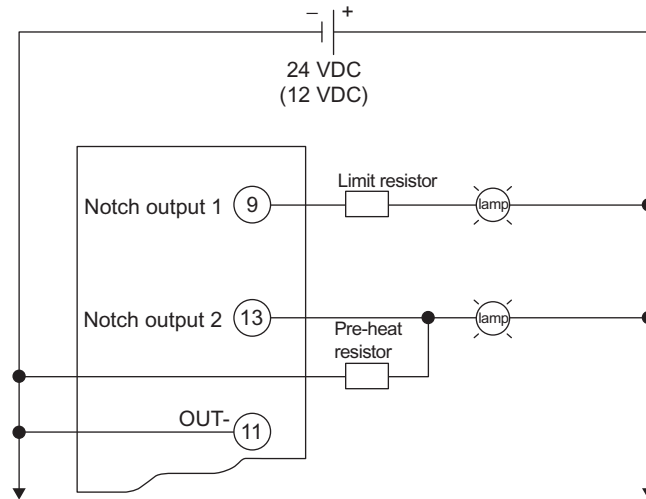

5.7 Module Operation

5.7.1 Operation Settings

(1) Overview

There are 4 operation settings, as listed below:

- Data Setting Operations
- Data Monitoring Operations
- Permission Operations
- Forced Status Operations

(2) Operation Flowchart

The following flowchart outlines the flow of operation for the Counter Module.

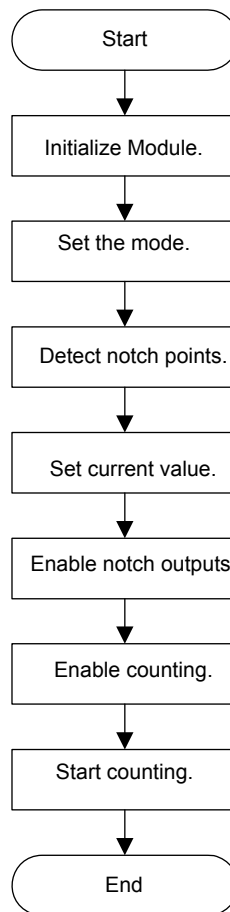

(3) Related Reference

Use the following I/O data to execute instructions.

(a) Output Coil

Symbol	Signal Name	Details
M-SETn	Mode Set	This is the counter mode setting reference. The following settings are made: <ul style="list-style-type: none"> • Pulse count mode • Notch output mode • External latch input polarity
N-SETn	Notch Point Set	This is the notch point set value preset reference. Write the notch point setting in the corresponding output register in advance. The notch point is set when this signal goes from OFF to ON.
P-SETn	Current Value Set	This is the Counter's current value preset reference. Write the current value setting in the corresponding output register in advance. The current value is set when this signal goes from OFF to ON.

Note: The letter "n" at the end of the signal denotes counter number 1 or 2.

(b) Command Data Configuration

1. Mode Set

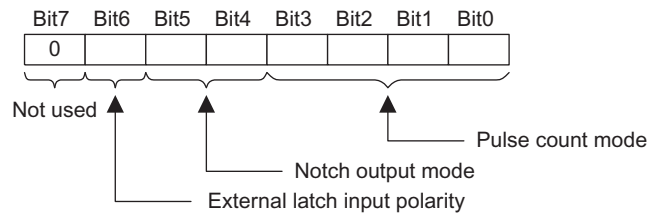

Output Register No.	Setting Details
1st byte	Mode setting (MSET1)
2nd byte	—
3rd byte	—
4th byte	—
5th byte	Mode setting (MSET2)
6th byte	—
7th byte	—
8th byte	—

Note: Set the unused bytes (bytes 2, 3, 4, 6, 7, and 8) to 0.

2. Notch Point Set

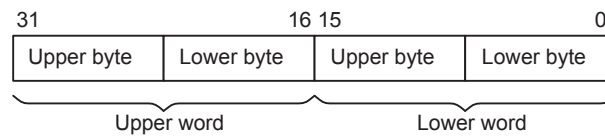

Output Register No.	Setting Details
1st byte	Notch point P _m (lower bytes) (N-SET _n)
2nd byte	
3rd byte	Notch point P _m (upper bytes) (N-SET _n)
4th byte	
5th byte	Notch point P _m ' (lower bytes) (N-SET _n)
6th byte	
7th byte	Notch point P _m ' (upper bytes) (N-SET _n)
8th byte	

Note: 1. The letter "n" at the end of the signal denotes counter number 1 or 2.

2. The allowable set range is as follows:

$$0 \leq P_m \leq \text{FFFFFFFFh}, \quad 0 \leq P_m' \leq \text{FFFFFFFFh}$$

However, P_m must be equal or smaller to/than P_m'.

3. The notch point settings are shared by Counters 1 and 2 and can be set at the same time.

3. Current Value Set

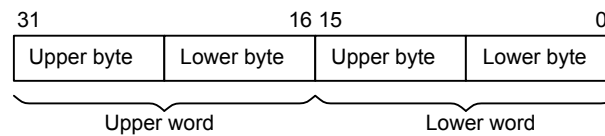

Output Register No.	Setting Details
1st byte	Current value set value (lower bytes) (P-SET1)
2nd byte	
3rd byte	
4th byte	
5th byte	Current value set value (upper bytes) (P-SET2)
6th byte	
7th byte	
8th byte	

(4) Setting Procedure

The Counter Module's operations are detailed below.

1. Set the mode setting.

- a) Set the output coils for the Mode Set (M-SETn).
- b) Set the Mode Set (M-SET1) in the lower byte of output register OWxxxxx+4 or the Mode Set (M-SET2) in the lower byte of output register OWxxxxx+6.
- c) Set the pulse count mode.

The following table shows the pulse count mode settings.

Pulse Count Mode	Bit 3	Bit 2	Bit 1	Bit 0
Phase-A and phase-B pulses, ×1 multiplication*	0	0	0	0
Phase-A and phase-B pulses, ×2 multiplication	0	0	0	1
Phase-A and phase-B pulses, ×4 multiplication	0	0	1	0
Sign and pulse, ×1 multiplication	0	0	1	1
Sign and pulse, ×2 multiplication	0	1	0	0
Increment and decrement pulses, ×1 multiplication	0	1	0	1
Increment and decrement pulses, ×2 multiplication	0	1	1	0
Not used. (Will cause a setting error.)	0 : 1	1 : 1	1 : 1	1 : 1

* The phase-A and phase-B pulses, ×1 multiplication setting is the mode set at the factory and the default mode. The pulse count mode will be reset to this mode automatically when the power is turned ON.

d) Set the notch output mode.

The following table shows the notch output mode settings.

Notch Output Mode	Bit 5	Bit 4
Latch mode *	0	0
State mode	0	1
Special state mode	1	0
Not used. (Will cause a setting error.)	1	1

* Latch mode is the mode set at the factory and the default mode. The notch output mode will be reset to latch mode automatically when the power is turned ON.

e) Set the external latch polarity.

The following table shows the external latch polarity settings.

External Latch Polarity	Bit 6
Operates when signal goes from OFF to ON. *	0
Operates when signal goes from ON to OFF.	1

* The default setting (set at the factory). The polarity will be reset to this setting automatically when the power is turned ON.

IMPORTANT

When setting control references overlap or the set value exceeds the allowable range, the values will not be set in the Module. In this case, ACK is not turned ON and ERR is turned ON. Set the correct values and set the mode settings again.

2. Set the notch point settings.
 - a) Set the output coils for the Notch Point Set (N-SETn).
 - b) Make the following settings in the output registers.

Register Address	Output Register No.	Setting Details	Setting Range
OWxxxxx+4	1st byte	Notch point Pm (lower bytes)	0 to FFFFFFFF (hexadecimal)
	2nd byte		
OWxxxxx+5	3rd byte	Notch point Pm (upper bytes)	
	4th byte		
OWxxxxx+6	5th byte	Notch point Pm' (lower bytes)	0 to FFFFFFFF (hexadecimal)*
	6th byte		
OWxxxxx+7	7th byte	Notch point Pm' (upper bytes)	
	8th byte		

* A setting range error will occur if the setting exceeds the upper limit of the counting range.

3. Set the current value set value.
 - a) Set the output coils for the Current Value Set (P-SETn).
 - b) Make the following settings in the output registers.

Register Address	Output Register No.	Setting	Setting Range
		Notch Point Setting	
OWxxxxx+4	1st byte	Current value set value (lower bytes) (P-SET1)	0 to FFFFFFFF (hexadecimal)
	2nd byte		
OWxxxxx+5	3rd byte		
	4th byte		
OWxxxxx+6	5th byte	Current value set value (upper bytes) (P-SET2)	0 to FFFFFFFF (hexadecimal)
	6th byte		
OWxxxxx+7	7th byte		
	8th byte		

4. Enable the notch output.

Turn the Notch Output Enable (N-ENBn) output coil from OFF to ON.
5. Enable counting.

Turn the Count Enable (C-ENBn) output coil from OFF to ON.

Pulse counting will start.

5.7.2 Ladder Programs

This section describes examples of ladder programming for the Counter Module.

(1) Setting the Mode and the Notch Points

(a) Setting Details

The following table shows the settings to be made:

Setting Name		Details
Mode settings	Pulse input mode	Phase-A and phase-B pulses, ×4 multiplication
	Notch output mode	State mode
	External latch input polarity	Enabled when turned from OFF to ON.
Notch point settings	P1	200000
	P1'	400000 (hexadecimal)

The following diagram shows the function of the settings.

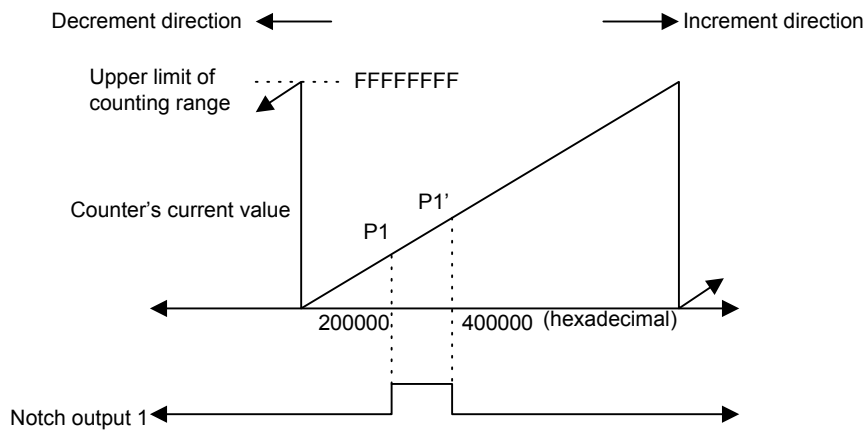

(b) Ladder Program Example

◀ EXAMPLE ▶

The following table shows the I/O registers used in this example

Register Name	Register Address
Input register number allocation	IW0000 to IW0006
Output register number allocation	OW0010 to OW0017
Input relays	IB00020 to IB0002F
Input registers	IW0003 to IW0006
Output coils	OB00120 to OB0013F
Output registers	OW0014 to OW0017
Internal register	MW00200

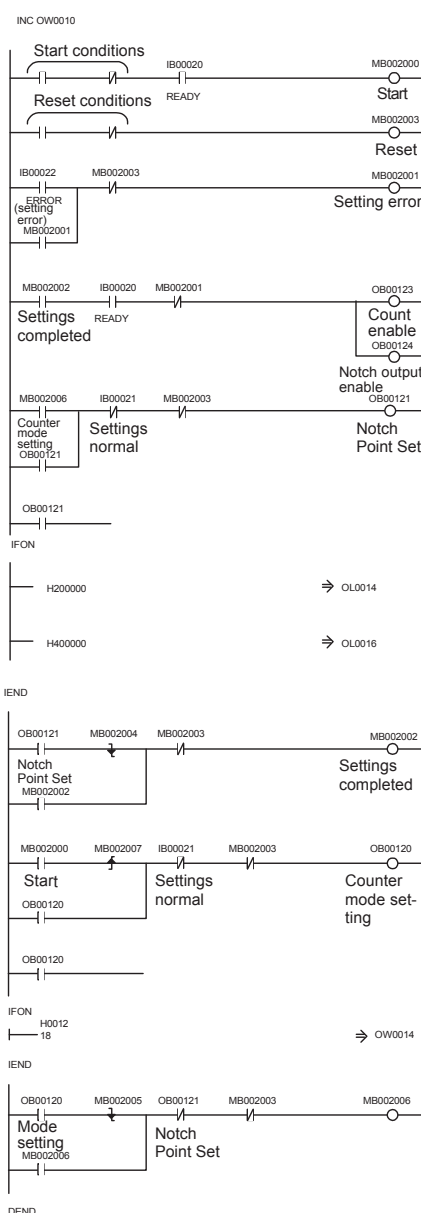

Scan counter

When the conditions for the settings operation are satisfied, MB002000 is turned ON and the settings operation starts. The Module won't be reset if one scan is shorter than the communications period. Keep the reset coil ON for longer than the communications period.

If an error occurs in the settings operation, MB002001 will be turned ON and will remain ON.

When the counter mode and notch point settings have been completed, counting and the notch output are enabled.

⇒ OL0014 Notch Point (P1) Set

⇒ OL0016 Notch Point (P1') Set

The notch point setting process might not be completed if one scan is shorter than the communications period, so an interlock is set up when OB00021 goes from OFF to ON.

⇒ OW0014 Phase-A and phase-B, .4 multiplication
Notch mode: State mode
External latch polarity: OFF to ON

Mode setting completed

(c) Output Coil Timing Chart

The following timing chart shows the status of output coils as the preceding ladder program is executed

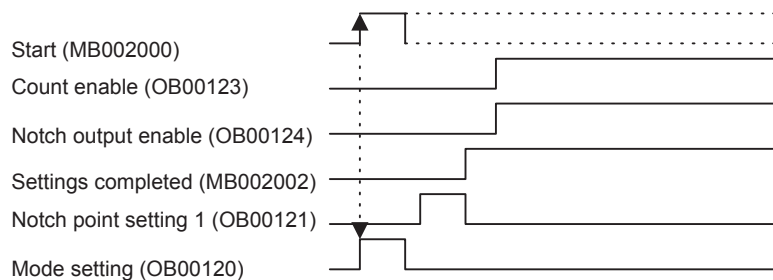

(2) Setting the Current Value

◀ EXAMPLE ▶

This section shows an example of a ladder program used to set the current value.

The following table shows the I/O registers used in this example

Register Name	Register Number
Input relays	IB00020 to IB0002F
Input registers	IW0003 to IW0006
Output coils	OB00120 to OB0013F
Output registers	OW0014 to OW0017
Internal register	MW00300

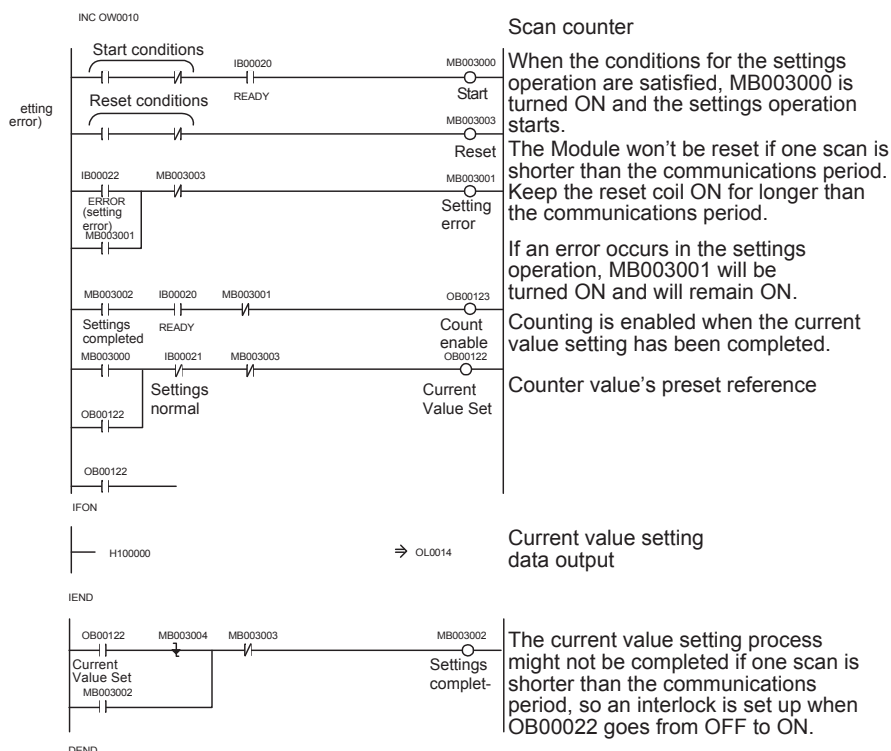

Pulse Output Module

This section provides an overview of the Pulse Output Module: 2CH (120MMB20230)/ (PL2910).

6.1 Summary of Module Functions	6-2
6.2 External Appearance and Configuration	6-4
6.3 System Configuration	6-8
6.3.1 Example of System Configuration	6-8
6.3.2 Interface with the Host Controller	6-9
6.4 Specifications	6-10
6.4.1 General Specifications	6-10
6.4.2 Performance Specifications	6-11
6.5 External I/O Signals and Connection Examples	6-17
6.6 References	6-20
6.6.1 I/O Allocations	6-20
6.6.2 Output Coils	6-22
6.6.3 Parameters	6-23
6.6.4 Output Registers	6-24
6.6.5 Input Relays	6-25
6.6.6 Input Registers	6-26
6.6.7 Monitoring Data	6-26
6.7 Module Operation	6-31
6.7.1 Operation Flowchart	6-31
6.7.2 Positioning Function	6-32
6.7.3 Jog Operation	6-37
6.7.4 Zero Point Return	6-40

6.1 Summary of Module Functions

There are two types of Pulse Output Modules available as described below.

- JAMSC-120MMB20230: Module for baud rate of 4 Mbps/1 Mbps
- JEPMC-PL2910: Module for baud rate of 10 Mbps/4 Mbps

Only the MECHATROLINK baud rate differs between these Modules. The DIP switch settings are also different, however, the functions are the same as the Pulse Output Modules.

This section describes the operations that can be performed with the Pulse Output Module.

(1) Positioning Function

When the MOVn signal turns ON, pulses are output to move from the current position to the target position at the speed set in the parameters.

- The speed and acceleration/deceleration time are set in the parameters.

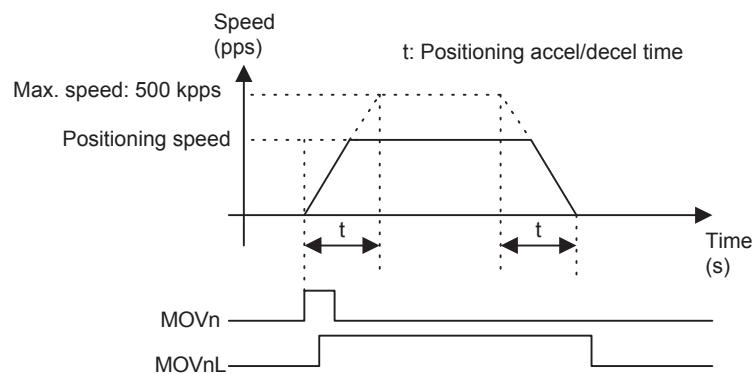

(2) JOG Operation Function

While the JOGn signal is ON, pulses will be output at the set speed and direction set.

- The speed and acceleration/deceleration time are set in the parameters.
- The JOG speed and JOG direction are specified by the REVn signal.

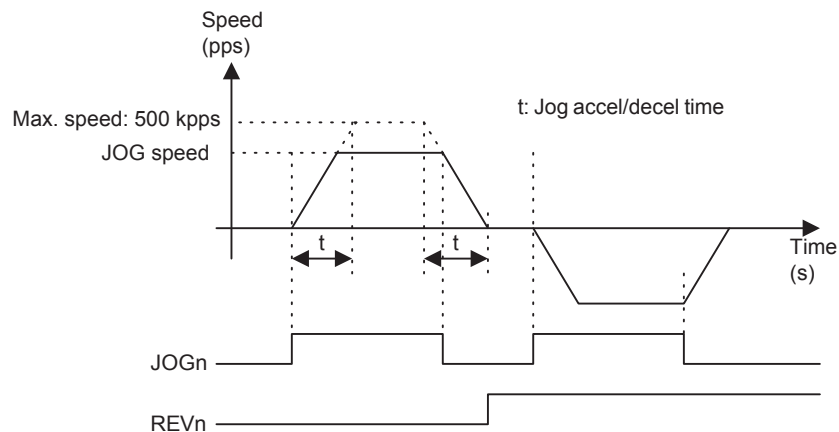

(3) Zero Point Return Function

When the ZRNn signal turns ON, pulses will be output at the set speed and direction.

- The acceleration/deceleration time, approach time, and creep speed are set in the parameters.
- The direction is specified by the REVn signal.

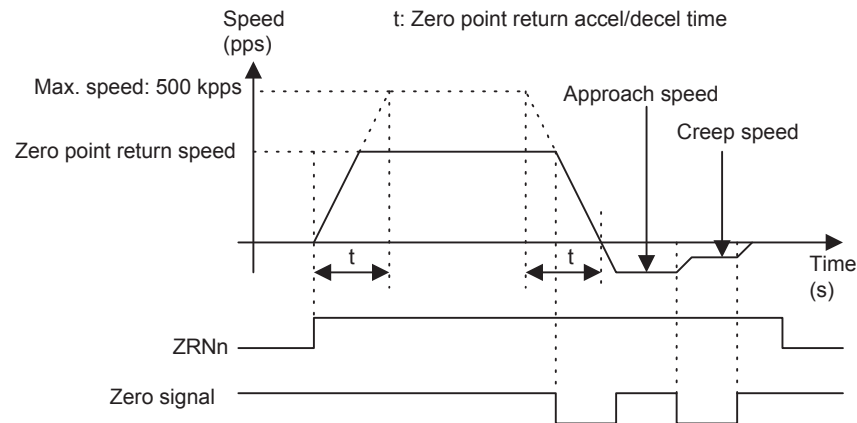

(4) Parameter Setting Function

The parameters set the operating conditions for the positioning, JOG operation, and zero point return functions.

Set the following output coils:

- Turn OFF MONSELn.
- Set the parameter number in PRMn0 through PRMn3. (See the following table.)
- Turn ON PSETn.

The following table shows the parameters that are specified in output coils PRMn0 through PRMn3.

Parameter No.	Settings
1	Output mode
2	JOG speed
3	Zero point return speed, zero point return acceleration/deceleration time
4	Zero point return approach speed, zero point return creep speed
5	Positioning speed, positioning acceleration/deceleration time
6	–
7	–
8	Acceleration/declaration mode
9	Two-stage acceleration/deceleration speed, second-stage acceleration/deceleration time
10	Asymmetrical acceleration/deceleration time, asymmetrical deceleration time
11	Asymmetrical acceleration/deceleration bias speed

(5) Monitor Function

The Pulse Output Module is equipped with the following three data monitoring functions.

No.	Monitor	Details
1	Current Position Monitor	Monitors the Pulse Output Module's current position.
2	Alarm Monitor	Monitors the Pulse Output Module's alarm history.
3	Parameter Monitor	Monitors the various parameter settings.

6.2 External Appearance and Configuration

The following diagram shows the Pulse Output Module's external parts.

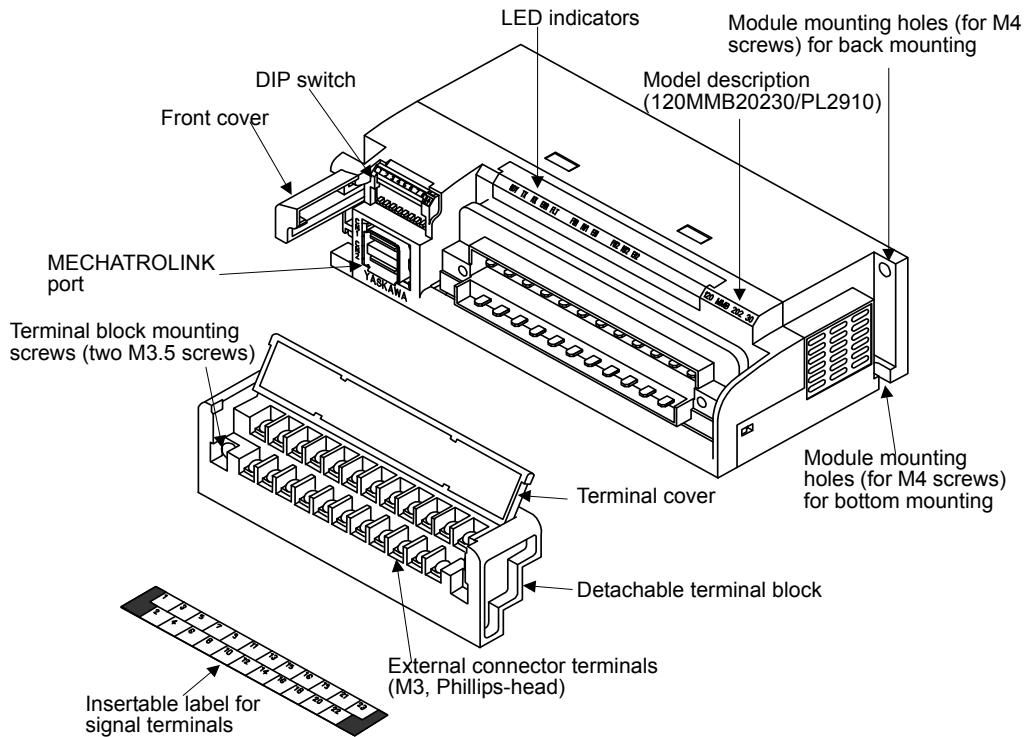

(1) LED Indicators

The following table shows the functions of the Counter Module's LED indicators.

Indicator Name	Indicator Color	Meaning When Lit
RDY	Green	The Module is operating normally.
TX	Green	Data is being transmitted through MECHATROLINK.
RX	Green	Data is being received through MECHATROLINK.
ERR	Red	A MECHATROLINK communication error occurred.
FLT	Red	A Module error occurred.
FW1	Green	Channel 1 is operating in the counterclockwise direction.
RV1	Green	Channel 1 is operating in the clockwise direction.
ER1	Red	Channel 1 operating error
FW2	Green	Channel 2 is operating in the counterclockwise direction.
RV2	Green	Channel 2 is operating in the clockwise direction.
ER2	Red	Channel 2 operating error

(2) DIP Switch Settings

The settings for the Pulse Output Module's DIP switch are explained below.

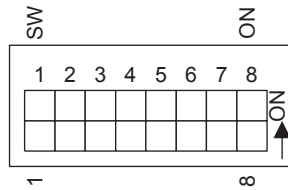

(a) 120MMB20230

Pin No.	Setting	Function	Factory Setting
1 to 5	ON	Pins 1 through 5 set the Pulse Output Module's slave address. (See the table on the following page.)	1: ON
	OFF		2 to 5: OFF
6	ON	Sets the Pulse Output Module's baud rate to 1 Mbps.	OFF
	OFF	Sets the Pulse Output Module's baud rate to 4 Mbps.	
7	ON	For system use. Leave pin 7 OFF.	OFF
	OFF		OFF
8	ON	For system use. Leave pin 8 OFF.	OFF
	OFF		OFF

(b) PL2910

Pin No.	Setting	Function	Factory Setting
1 to 5	ON	Pins 1 through 5 set the Pulse Output Module's slave address. (See the table on the following page.)	1: ON
	OFF		2 to 5: OFF
6	ON	When SW8 is ON, set the communication data length to 32 bytes. When SW8 is OFF, set SW6 to OFF, too.	OFF
	OFF	When SW8 is ON, set the communication data length to 17 bytes. When SW8 is OFF, set SW6 to OFF, too.	
7	ON	For system use. Leave pin 7 OFF.	OFF
	OFF		OFF
8	ON	Sets the Pulse Output Module's baud rate to 10 Mbps.	ON
	OFF	Sets the Pulse Output Module's baud rate to 4 Mbps.	

IMPORTANT

- SW6 and SW7 of the Pulse Output Module become effective when the external main power supply (24 VDC) is turned ON.
To change the setting, turn ON the external main power supply (24 VDC) again.
- PL2910 does not operate at baud rate of "1 Mbps."

The following table shows the possible slave address settings.

Slave Address	DIP Switch Pin					Slave Address	DIP Switch Pin				
	1	2	3	4	5		1	2	3	4	5
Not used	0	0	0	0	0	16	0	0	0	0	1
1	1	0	0	0	0	17	1	0	0	0	1
2	0	1	0	0	0	18	0	1	0	0	1
3	1	1	0	0	0	19	1	1	0	0	1
4	0	0	1	0	0	20	0	0	1	0	1
5	1	0	1	0	0	21	1	0	1	0	1
6	0	1	1	0	0	22	0	1	1	0	1
7	1	1	1	0	0	23	1	1	1	0	1
8	0	0	0	1	0	24	0	0	0	1	1
9	1	0	0	1	0	25	1	0	0	1	1
10	0	1	0	1	0	26	0	1	0	1	1
11	1	1	0	1	0	27	1	1	0	1	1
12	0	0	1	1	0	28	0	0	1	1	1
13	1	0	1	1	0	29	1	0	1	1	1
14	0	1	1	1	0	30	0	1	1	1	1
15	1	1	1	1	0	Not used	1	1	1	1	1

Note: ON is 1. OFF is 0.



- The upper limit of an effective slave address differs depending on the settings of the MECHATROLINK communication method (speed, cycle, etc.).

IMPORTANT

- Use the PL2910 Module at baud rate of 10 Mbps under the following conditions:
 - Set the communication cycle to 1 ms or more.
 - Set the communication cycle to 2 ms or more when asymmetrical acceleration/deceleration function is used for two axes simultaneously.

(3) Terminal Block Terminal Layout

The following diagram shows the layout of terminals on the Pulse Output Module's terminal block.

1 FG	3 CCW1	5 CW1	7 COFF1	9 BFRE1	11 OVER1	13 TIMG1	15 +5V	17 OUT1	19 ZERO1	21 IN1	23 +24V
2 CCW2	4 CW2	6 COFF2	8 BFRE2	10 OVER2	12 TIMG2	14 0 (5V)	16 OUT2	18 ZERO2	20 IN2	22 024V	

Terminal No.	Signal Name	Signal Function
1	FG	Frame ground
2	CCW2	Channel 2 CCW pulse output
3	CCW1	Channel 1 CCW pulse output
4	CW2	Channel 2 CW pulse output
5	CW1	Channel 1 CW pulse output
6	C-OFF2	Channel 2 output current OFF
7	C-OFF1	Channel 1 output current OFF
8	B-FREE2	Channel 2 brake signal release
9	B-FREE1	Channel 1 brake signal release
10	OVER2	Channel 2 overheat input
11	OVER1	Channel 1 overheat input
12	TIMING2	Channel 2 magnetic excitation timing input
13	TIMING1	Channel 1 magnetic excitation timing input
14	0 (5V)	External power supply 0 V
15	+5V	External power supply 5 V
16	OUT2	Channel 2 general-purpose output
17	OUT1	Channel 1 general-purpose output
18	ZERO2	Channel 2 zero point signal
19	ZERO1	Channel 1 zero point signal
20	IN2	Channel 2 general-purpose output
21	IN1	Channel 1 general-purpose output
22	024V	External power supply 0 V
23	+24V	External power supply 24 V

6.3 System Configuration

6.3.1 Example of System Configuration

The following diagram shows an example of a system configuration.

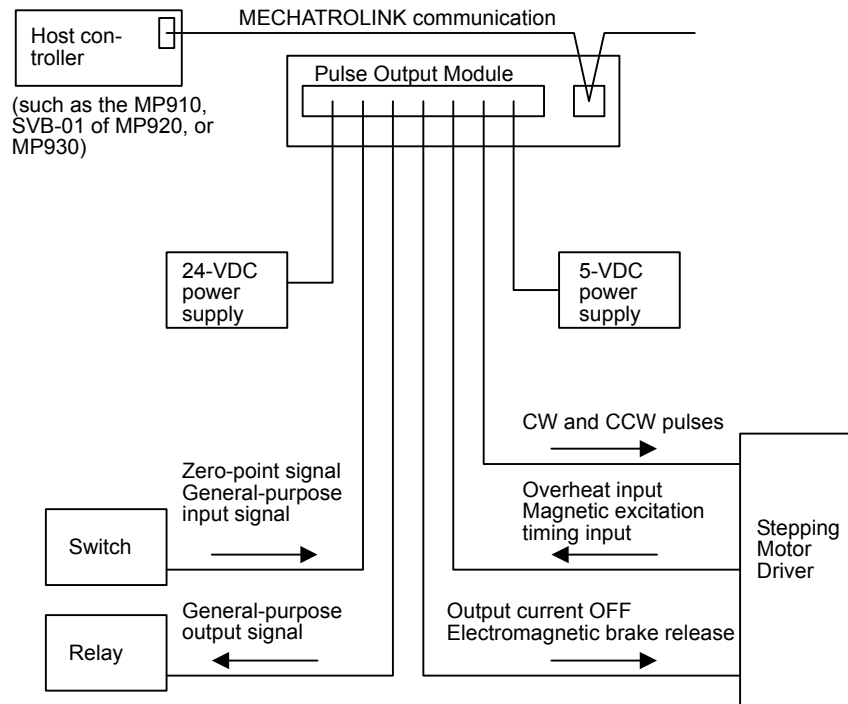

Theoretically, up to 29 Modules can be connected to a MECHATROLINK communication line. The maximum number of Modules that can be used, however, is limited by the host controller specifications. Refer to *1.1.3 MECHATROLINK Transmission Specifications* for details.

You can connect the Modules to any point on the MECHATROLINK communication network.

6.3.2 Interface with the Host Controller

The following diagram shows the interfaces between the Pulse Output Module and the host controller and between the Pulse Output Module and external devices.

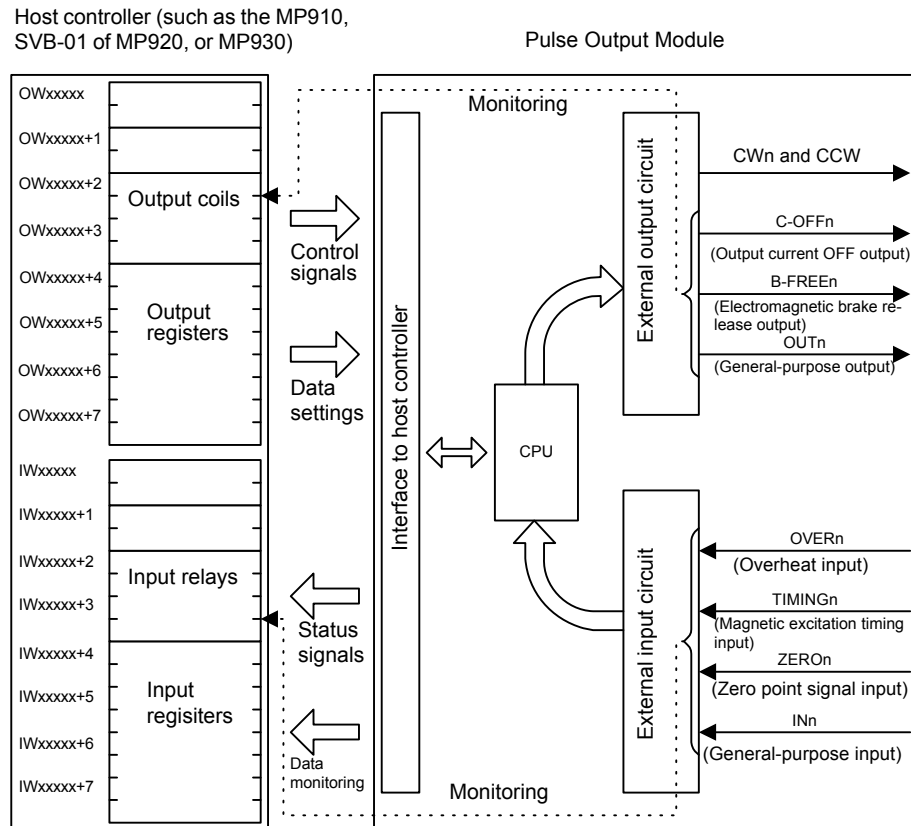

The following table explains the signals.

Name	Explanation	Reference
Output coils	The output coils are control signals from the host controller to the Pulse Output Module.	6.6.2 <i>Output Coils</i>
Output registers	The output registers are used together with the output coils to set numeric values from the host controller to the Pulse Output Module.	6.6.4 <i>Output Registers</i>
Input relays	The input relays are status signals from the Pulse Output Module to the host controller.	6.6.5 <i>Input Relays</i>
Input registers	The input registers are used together with the output coils when monitoring numeric values in the Pulse Output Module.	6.6.6 <i>Input Registers</i>

6.4 Specifications

6.4.1 General Specifications

The general specifications of the Pulse Output Module are shown below.

Item		Specifications
Environmental Conditions	Ambient Operating Temperature	For 120MMB20230: 0 to 60°C For PL2910: 0 to 55 °C
	Storage Temperature	-25 to 85°C
	Operating Humidity	30% to 95% (with no condensation)
	Storage Humidity	5% to 95% (with no condensation)
	Pollution Level	Pollution level 1 according to JIS B 3501
	Corrosive Gas	No corrosive gas
	Operating Altitude	Less than 2,000 m above sea level
Mechanical Operating Conditions	Vibration Resistance	10 to 57 Hz with half-amplitude of 0.075 mm 57 to 150 Hz at fixed acceleration of 9.8 m/s ² 10 sweeps in the X, Y, and Z directions (sweep period: 1 octave/min) (conforming to JIS B 3502)
	Shock Resistance	Peak acceleration of 147 m/s ² twice for 11 ms in X, Y, and Z directions (conforming to JIS B 3502)
Electrical Operating Conditions	Noise Resistance	1,000 Vp-p in normal mode with pulse widths of 100 ns and 1 µs and rise time of 1 ns (with impulse noise simulator) (conforming to JIS B 3502)
Dielectric Strength		1,500 VAC for 1 min or 1,800 VAC for 1 s between the I/O terminals and internal circuit, between I/O commons
Insulation Resistance		100 MΩ min. at 500 VDC between I/O terminals and internal circuit and between output commons (at room temperature and humidity)
Installation Requirements	Ground	Ground to 100 Ω or less
	Installation Orientation	The Module can be mounted in three directions. Refer to 3.1.2 <i>Mounting Orientation</i> for details.
	Cooling Method	Natural cooling
	Mass	Approx. 350 g
	Dimensions (mm)	161 × 44 × 79 (W × H × D) (Not including the terminal block)

6.4.2 Performance Specifications

(1) Hardware Specifications

The hardware specifications of the Pulse Output Module are shown below.

Item	Specifications
Name	Pulse Output Module (2 Channels)
Model Number	JAMSC-120MMB20230, JEPMC-PL2910
Model Description	V_POUT-2AXIS/PL2910
Functions	Pulse positioning, JOG operation, zero point return
Number of Circuits	2 circuits
Communication Protocol	MECHATROLINK
I/O Allocations	Digital outputs: 32 points Output registers: 4 registers Digital inputs: 32 points Input registers: 4 registers
External Power Supply	24 VDC (20.4 to 26.4 VDC)
Internal Current Consumption	24 V 150 mA, 5 V 300 mA
Hot Swapping	Not permitted.
Maximum Heating Value	3.6 W

(2) Performance Specifications

The performance specifications of the Pulse Output Module are shown below.

Item	Specifications	
Pulse Output	Pulse Output Method <ul style="list-style-type: none"> • Set the pulse output method in the control program as the Pulse Output Mode. • There are two pulse output methods. <ul style="list-style-type: none"> • CW and CCW pulses • Sign and pulses 	
	Maximum Output Speed	500 kpps
	Pulse Output Voltage	5 VDC
	Pulse Input Circuits	Open collector outputs External power supply: 5 VDC, 10 mA/circuit
	External Control Signals	The following signals can be input from and output to external devices such as Stepping Motor Driver Units. <ul style="list-style-type: none"> • Overheat input: 5 VDC, sourcing input • Magnetic excitation timing input: 5 VDC, sourcing input • Output current OFF: 5 VDC, sinking output • Electromagnetic brake release: 5 VDC, sinking output • Zero point signal input: 24 VDC, sourcing input • General-purpose input: 24 VDC, sourcing or sinking input • General-purpose output: 24 VDC, sinking output Refer to 6.5 <i>External I/O Signals and Connection Examples</i> for details on these I/O signals.
Monitor Functions	The following signals can be monitored from the control program. <ul style="list-style-type: none"> • READY: ON when the Pulse Output Module is operating normally. • PACK: ON when parameter settings have been completed normally. • PNACK: ON when parameter settings have not been completed normally (setting error). 	

(3) Pulse Output Timing

The following timing charts show the forward and reverse timing of pulse outputs, which depends on the pulse output mode being used.

Pulse Output Mode	Forward Timing	Reverse Timing
Sign and Pulses		
CW and CCW pulses		

Note: The maximum pulse output speed is 500 kpps.

(4) Pulse Output Operation Example

The following timing chart shows operation in the "sign and pulses" output mode.

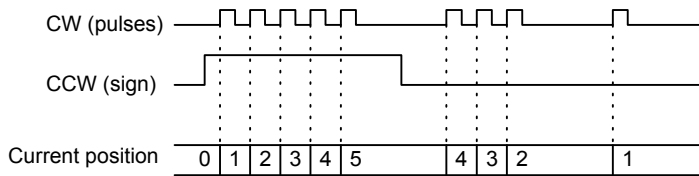

Note: The position range is -2,147,483,648 to 2,147,483,647.

(5) External Output Signal Specifications

The specifications of external output signals are shown below.

Item		Specifications
CW and CCW Pulse Outputs	Pulse Output Modes	CCW (forward) and CW (reverse), or sign and pulses.
	Maximum Output Frequency	500 kpps
	Load Voltage	5 V
	Maximum Load Current	18 mA/point
	Output Voltage Drop	0.6 V max. (typ.)
Output Current OFF * and Electromagnetic Brake Release Outputs	Rated Voltage	5 VDC
	Allowable Voltage Range	4.75 to 5.25 VDC
	Output Format	Sinking
	Maximum Load Current	17 mA max./point
	Output Voltage Drop	1.0 V max. (typ.)
	Output Delay Times	OFF to ON: 1.5 ms max. ON to OFF: 1.5 ms max.
	Leakage Current When OFF	0.4 μ A max.
	Output Type	Photocoupler output
	Number of Commons	1
	Output Protection	Unprotected outputs according to JIS B 3501
General-purpose Outputs	Rated Voltage	24 VDC
	Allowable Voltage Range	19.2 to 30 VDC
	Output Format	Sinking
	Maximum Load Current	100 mA max./point
	Output Voltage Drop	3.5 V max. (typ.)
	Output Delay Times	OFF to ON: 1.5 ms max. ON to OFF: 1.5 ms max.
	Leakage Current When OFF	1 mA max.
	Output Type	Transistor output
	Number of Commons	1
	Output Protection	Unprotected outputs according to JIS B3501

* "Output Current OFF" means that current stops flowing when the signal is turned ON; and current flows when the signal is turned OFF.

(6) External Input Signal Specifications

The specifications of external input signals are shown below.

Item	Specifications	
Overheat and Magnetic Excitation Timing	Rated Voltage	5 VDC
	Allowable Voltage Range	4.75 to 5.25 VDC
	Input Format	Sourcing
	Rated Current	7.0 mA
	Input Impedance	470 Ω
	Standard Operating Range	Min. ON voltage: 2.13 VDC Max. OFF voltage: 1.14 VDC
	Input Delay Times	OFF to ON: 0.5 ms max. ON to OFF: 0.8 ms max.
	Isolation Method	Photocoupler
Zero Point Signal	Rated Voltage	24 VDC
	Allowable Voltage Range	19.2 to 30 VDC
	Input Format	Sourcing
	Rated Current	10.0 mA
	Input Impedance	2.2 k Ω
	Standard Operating Range	Min. ON voltage: 16.9 VDC Max. OFF voltage: 4.8 VDC
	Input Delay Times	OFF to ON: 1.0 μ s max. ON to OFF: 1.0 μ s max.
	Isolation Method	Photocoupler
General-purpose Inputs	Rated Voltage	24 VDC
	Allowable Voltage Range	19.2 to 30 VDC
	Input Format	Sourcing
	Rated Current	5.0 mA
	Input Impedance	4.7 k Ω
	Standard Operating Range	Min. ON voltage: 13.1 VDC Max. OFF voltage: 6.3 VDC
	Input Delay Times	OFF to ON: 0.5 ms max. ON to OFF: 0.5 ms max.
	Isolation Method	Photocoupler

(7) Circuit Configuration

CAUTION

- Connect a fuse appropriate for the load specifications in series with the load. The output circuit is not equipped with a built-in fuse.

There is a risk of fire, damage to the load equipment, or damage to the output circuits if there is a load short-circuit or overload.

The following diagram shows the circuit configuration of external I/O signals.

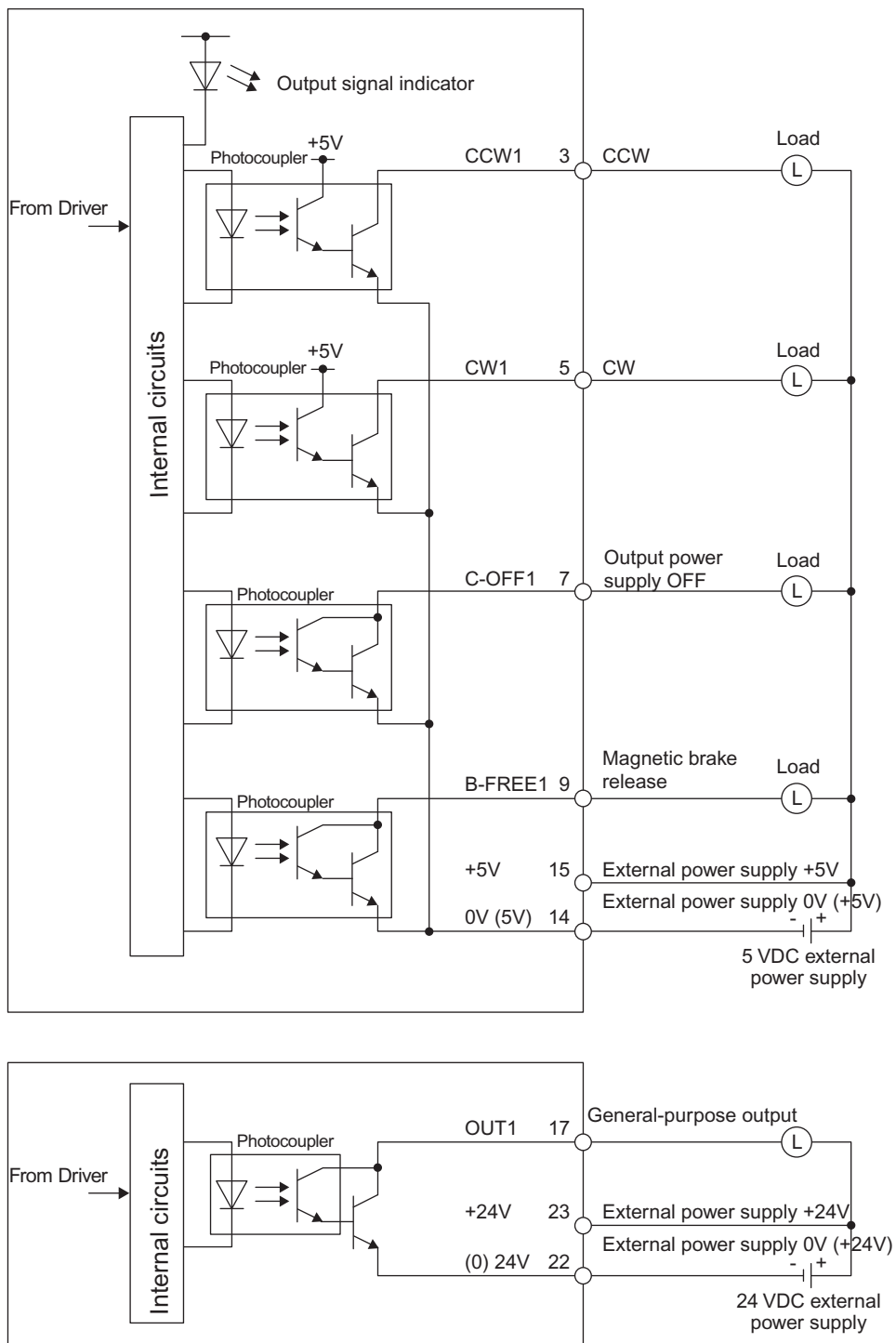

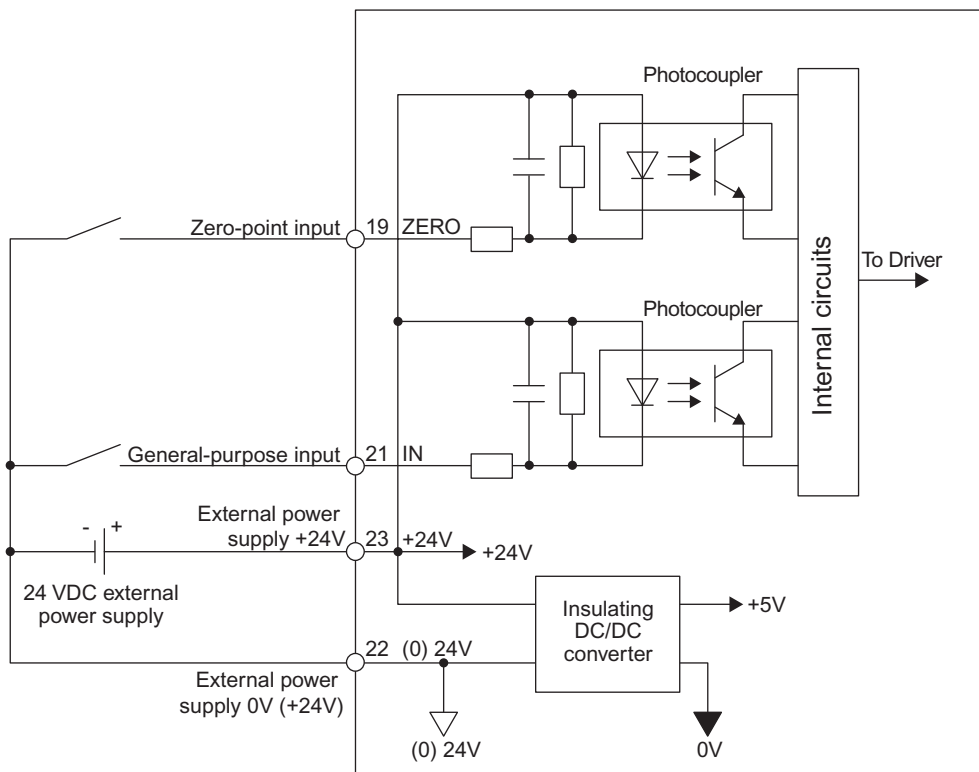
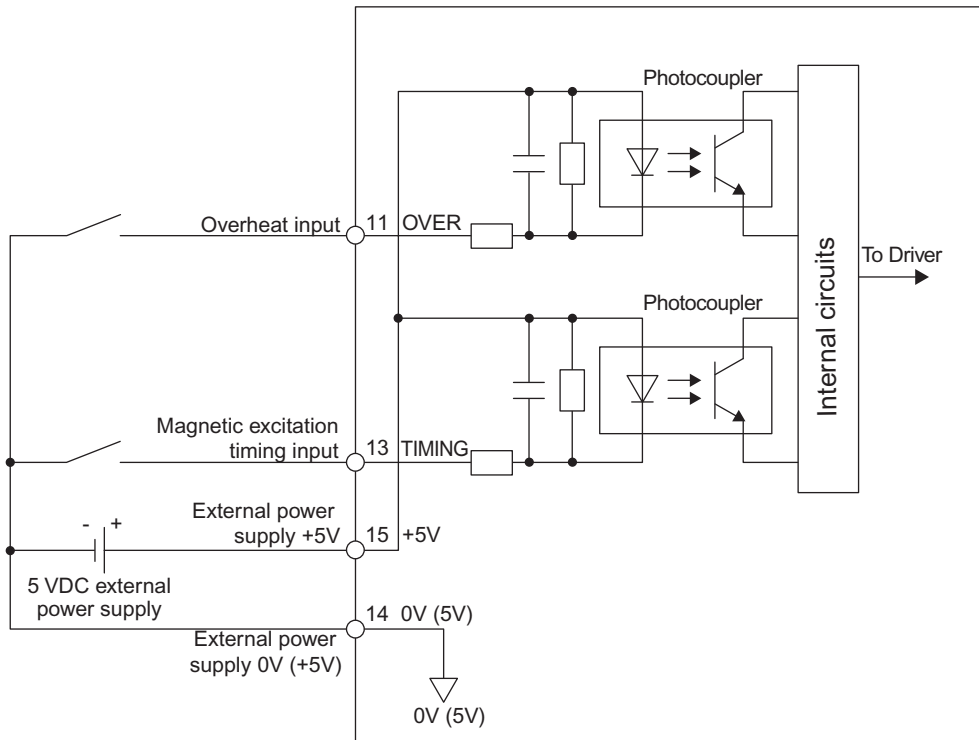

6.5 External I/O Signals and Connection Examples

The following table summarizes the external I/O signals.

Signal Name		Specifications
Output Signals	CWn CCWn	Pulses are output from the CW or CCW terminal. There are two pulse output modes: <ul style="list-style-type: none"> • CW and CCW pulses method • Sign and pulses method (The sign signal is output to the CCW and pulses are output to the CW.) This setting is made with the Module's Pulse Output Mode setting.
	C-OFFn (Output Current OFF*)	Connects to the current OFF input terminals of an external device such as a Stepping Motor Driver Unit. This signal is controlled by turning output coil COFFn ON and OFF. This signal is turned OFF automatically by the system when an error occurs in the Pulse Output Module or when the overheat input is turned ON.
	B-FREEN (Electromagnetic Brake Release Output)	Connects to the electromagnetic brake release input terminals of an external device such as a Stepping Motor Driver Unit. This signal is controlled by turning output coil BFREEN ON and OFF.
	OUTn (General-purpose Output)	This signal is controlled by turning the general-purpose output terminal output coil OUTn ON and OFF.
Input Signals	OVERn (Overheat Input)	Connects to the overheat output terminals of an external device such as a Stepping Motor Driver Unit. This signal is monitored with input relay OVERn.
	TIMINGn (excitation timing input)	Connects to the magnetic excitation timing output terminals of an external device such as a Stepping Motor Driver Unit. This signal is monitored with input relay TIMINGn.
	ZEROn (zero-point signal input)	Used as the zero-point signal when a zero point return is performed. This signal is monitored with input relay ZEROn.
	INn (general-purpose input)	This signal is monitored with the general-purpose input terminal input relay INn.

* "Output Current OFF" means that current stops flowing when the signal is turned ON; and current flows when the signal is turned OFF.

Note: The letter "n" at the end of the signals denotes channel number 1 or 2.

! CAUTION

- Connect a fuse appropriate for the load specifications in series with the load. The output circuit is not equipped with a built-in fuse.
There is a risk of fire, damage to the load equipment, or damage to the output circuits if there is a load short-circuit or overload.

The following shows a connection example of general-purpose I/O and zero-point input.

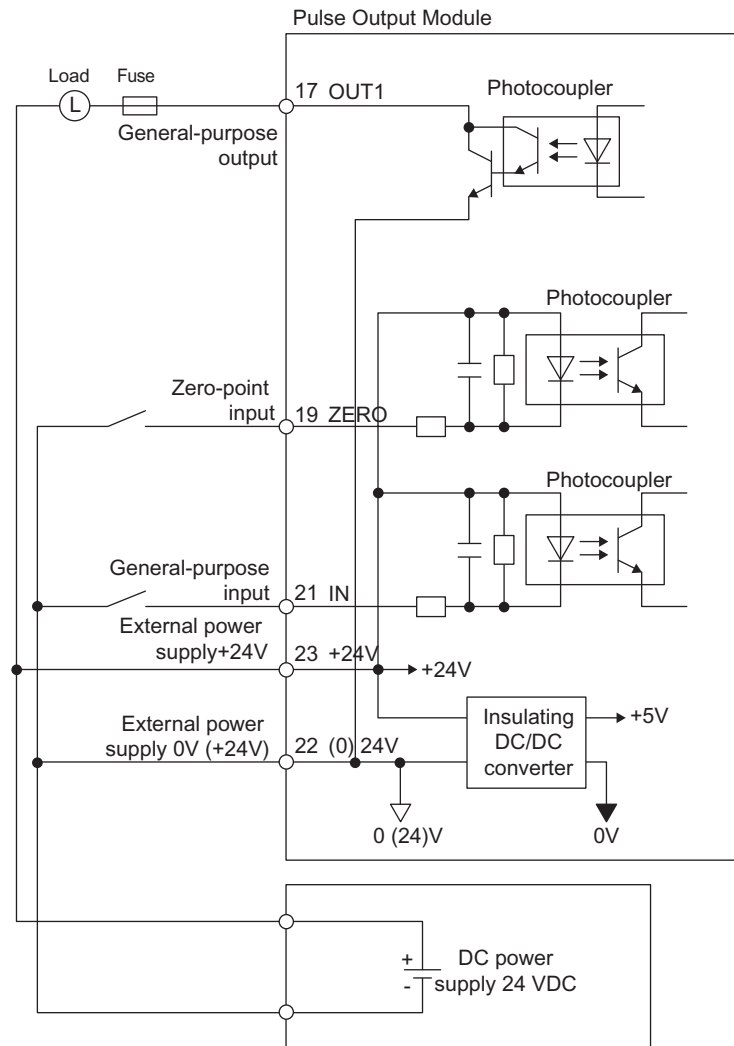

IMPORTANT

- Use crimp terminals that fit M3 screw for terminal block wiring.
- Do not connect anything to unused input terminals or output terminals.

The following shows a connection example with stepping motor driver.

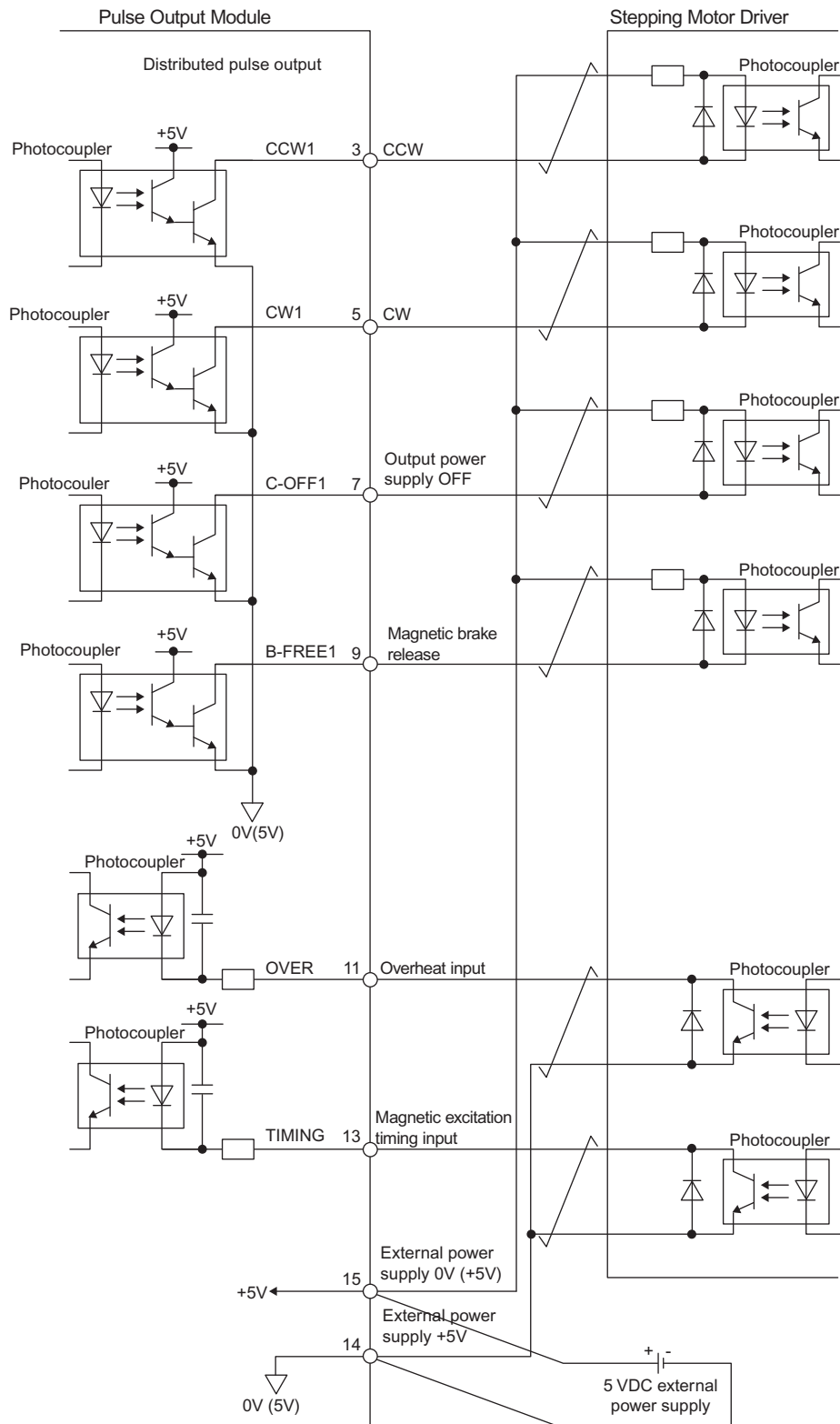

IMPORTANT

- Use crimp terminals that fit M3 screw for terminal block wiring.
- Do not connect anything to unused input terminals or output terminals.
- Use the shielded twisted-pair cable for the cable for terminal block wiring.

6.6 References

6.6.1 I/O Allocations

This section explains the Pulse Output Module I/O allocations.

For details, refer to *Machine Controller MP900/MP2000 Series MPE720 Software for Programming Device User's Manual* (SIEPC88070005).

(1) Purpose of I/O Allocations

The correspondence between the Pulse Output Module's internal signals and I/O registers must be defined in order for the Pulse Output Module to input signals from input devices and the CPU Module or output signals to output devices and the CPU Module. Set the I/O register numbers to define this correspondence for the Pulse Output Modules.

Allocate I/O with a Programming Device (MPE720). The results of the allocation are stored in the CPU Module's memory as an I/O allocation table.

(2) I/O Allocation Settings

(a) Setting the Leading and End I/O Register Numbers

The range of consecutive I/O register numbers allocated to the MECHATROLINK Master Module are set in the Module configuration definitions window.

◀ EXAMPLE ▶

In the example Module definitions window shown below, the I/O register range for an MP920 SVB-01 has been set to 0100 to 017F. The I/O registers allocated to the Pulse Output Module are set within this range.

Rack1			
No.	00	00	00
Module	MP920 ▼		SVB-01 ▼
Control CPU No.			
I/O Start Register			0100
I/O End Register			017F

(b) Transmission Cycle Settings

Set the MECHATROLINK transmission cycle in the Transmission Parameters Tab of the MECHATROLINK definitions window.

(c) Allocation of I/O Register Numbers

Set the Pulse Output Module's leading I/O register number in the I/O Assignment Tab of the MECHATROLINK definitions window.

ST#	TYPE	D	INPUT	SIDE	D	OUTPUT	SIDE	SCAN
01		<input type="checkbox"/>			<input type="checkbox"/>			<input type="checkbox"/>
02		<input type="checkbox"/>			<input type="checkbox"/>			<input type="checkbox"/>
...

(3) I/O Allocations

Set the following items in the I/O Assignment Tab.

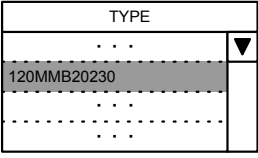
Item	Contents
ST#	Allocate station numbers to the devices connected to the MECHATROLINK network. Set station numbers in order beginning at 01.
TYPE	Set the model of MECHATROLINK Module connected at each station. Open the pull-down menu in the TYPE field and select 120MMB20230/PL2910. 
D	This field enables or disables inputs. Click the box to display a check-mark and disable inputs. Click the box again to remove the check-mark and enable inputs.
INPUT SIZE	Set the leading input register number (IWxxxx). The number of registers in the SIZE field is set to 8 automatically.
D	This field enables or disables outputs. Click the box to display a check-mark and disable outputs. Click the box again to remove the check-mark and enable outputs.
OUTPUT SIZE	Set the leading output register number (OWxxxx). The number of registers in the SIZE field is set to 8 automatically.
SCAN	Adjusts I/O timing. <ul style="list-style-type: none"> • Select "High" for high-speed scan. • Select "Low" for low-speed scan.

6.6.2 Output Coils

An output coil is a control signal sent from the host controller to the Pulse Output Module. The following table lists the output coils.

Address	Channel	Bit 7	Bit 6	Bit 5	Bit 4	Bit 3	Bit 2	Bit 1	Bit 0	
OWxxxxx+2	1	Lower byte	PRM13	PRM12	PRM11	PRM10	PSET1	MONSEL1	CAN1	ARST1
	Upper byte	OUT1	BFREE1	COFF1	–	REV1	ZRN1	JOG1	MOV1	
OWxxxxx+3	2	Lower byte	PRM23	PRM22	PRM21	PRM20	PSET2	MONSEL2	CAN2	ARST2
	Upper byte	OUT2	BFREE2	COFF2	–	REV2	ZRN2	JOG2	MOV2	

The following table summarizes the function of each signal.

Byte	Bit No.	Symbol	Signal Name	Details
Lower byte	0	ARSTn	Alarm Reset	This is the alarm reset reference. The signal operates when it goes from OFF to ON.
	1	CANn	Cancel	Cancels axis movement. The signal operates when it goes from OFF to ON.
	2	MONSELn	Monitor Selector	Switches the monitor mode. • OFF: Current position monitor • ON: Parameter monitor
	3	PSETn	Parameter Set/ Monitor Selector	Sets or monitors parameters.
	4 to 7	PRMn0 to PRMn3	Parameter Number Selectors	Selects the parameter number.
Upper byte	0	MOVn	Positioning	Starts positioning operation. The signal operates when it goes from OFF to ON.
	1	JOGn	JOG Operation	This reference controls JOG operation. • OFF: Stop • ON: Run
	2	ZRNn	Zero Point Return	This reference starts the zero point return operation. The signal operates when it goes from OFF to ON.
	3	REVn	JOG/Zero Point Return Direction	This reference determines the starting direction for JOG operation and zero point return operation. • OFF: Forward • ON: Reverse
	5	COFFn	Output Current ON	Controls the status of the output current ON terminal. When this signal is OFF, the output current ON terminal is OFF and when this signal is ON, the output current ON terminal is ON.
	6	BFREEN	Electromagnetic Brake Release	Controls the status of the electromagnetic brake release output terminal. When this signal is OFF, electromagnetic braking is used and when this signal is ON, electromagnetic braking is released.
	7	OUTn	General-purpose Output	Controls the status of the general-purpose output terminal. When this signal is OFF, the general-purpose output terminal is OFF and when this signal is ON, the general-purpose output terminal is ON.

Note: The letter "n" at the end of the signals donates channel number 1 or 2.

6.6.3 Parameters

Output coils PRMn0 to PRMn3 are set by the parameters.

The Pulse Output Module's parameters are shown in the following table.

Parameter No.	Parameter No. Setting				Name	Setting Range* ¹	Units	Initial Setting
	PRM n3	PRM n2	PRM n1	PRM n0				
00	OFF	OFF	OFF	OFF	–	–	–	–
01	OFF	OFF	OFF	ON	Output mode Bit 0: output mode	0: CW, CCW pulses 1: Sign and pulses	–	0
02	OFF	OFF	ON	OFF	JOG speed	1 to 50000	10 pps	500
					JOG acceleration/ deceleration time	50 to 5000	100 ms	100
03	OFF	OFF	ON	ON	Zero point return speed	1 to 50000	10 pps	500
					Zero point return acceleration/ deceleration time	50 to 5000	100 ms	100
04	OFF	ON	OFF	OFF	Zero point return approach speed	1 to 50000	10 pps	100
					Zero point return creep speed	1 to 50000	10 pps	50
05	OFF	ON	OFF	ON	Positioning speed	1 to 50000* ²	10 pps	500
					Positioning acceleration/ deceleration time	1 to 5000	100 ms	100
06	OFF	ON	ON	OFF	Reserved for future use	–	–	–
07	OFF	ON	ON	ON	Reserved for future use	–	–	–
08	ON	OFF	OFF	OFF	Acceleration/ declaration mode	0 to 2 0: Single-stage symmetric 1: Two-stage symmetric 2: Single-stage asymmetrical	–	0
09	ON	OFF	OFF	ON	Two-stage acceleration/ deceleration switching speed	1 to 50000	10 pps	500
					Second-stage acceleration/ deceleration time	50 to 5000	100 ms	100
10	ON	OFF	ON	OFF	Asymmetrical acceleration/ deceleration acceleration time	50 to 5000	100 ms	100
					Asymmetrical acceleration/ deceleration deceleration time	50 to 5000	100 ms	100
11	ON	OFF	ON	ON	Asymmetrical acceleration/ deceleration bias speed	0 to 50000	10 pps	0
12	ON	ON	OFF	OFF	Current position setting	-2147483647 to 2147483647	Pulse	0
13	ON	ON	OFF	ON	For system use	–	–	–
14	ON	ON	ON	OFF	For system use	–	–	–
15	ON	ON	ON	ON	For system use	–	–	–

* 1. Write the setting in the output register.

* 2. When using an MP900/MP2000 Series Machine Controller as the master of MECHATROLINK and the speed is set to a value greater than 32768; set the speed to a hexadecimal value for ladder programs.

Note: The letter "n" at the end of the signals denotes channel number 1 or 2.

IMPORTANT

- Set “Two-stage acceleration/deceleration switching speed” to a smaller value than “Positioning speed.”
- Set “Asymmetrical acceleration/deceleration bias speed” to a value multiplied by an integer of 500 pps and smaller than “Positioning speed.”
- Do not set the “Current position setting” to -2147483648.

6.6.4 Output Registers

Output registers are used together with output coils when setting numeric values from the host controller to the Pulse Output Module.

Output registers are used to make the following settings:

- Target position setting
- Parameter settings

IMPORTANT

The same output registers are used to set different data at different times, so be careful that the setting signals do not overlap.

The following table lists the output registers.

Register Address	Channel	Parameter Number* ¹				
		01	02	03	04	05
OWxxxx+4	1	Output mode* ²	JOG speed	Zero point return speed	Zero point return approach speed	Positioning speed
		Used by system				
OWxxxx+5	1	–	JOG acceleration/ deceleration time	Zero point return acceleration/ deceleration time	Zero point return creep speed	Positioning acceleration/ deceleration time
OWxxxx+6	2	Output mode* ²	JOG speed	Zero point return speed	Zero point return approach speed	Positioning speed
		Used by system				
OWxxxx+7	2	–	JOG acceleration/ deceleration time	Zero point return acceleration/ deceleration time	Zero point return creep speed	Positioning acceleration/ deceleration time

* 1. Output coils PRMn0 to PRMn3 (parameter number selectors) specify the parameters.

* 2. The output mode occupies the lower-place byte of the register.

Register Address	Channel	Parameter Number*				
		08	09	10	11	12
OWxxxx+4	1	Acceleration/ declaration mode	Two-stage acceleration/ deceleration switching speed	Asymmetrical acceleration/ deceleration acceleration time	Asymmetrical acceleration/ deceleration bias speed	Current position setting
OWxxxx+5		0	Second-stage acceleration/ deceleration time	Asymmetrical acceleration/ deceleration deceleration time		
OWxxxx+6	2	Acceleration/ declaration mode	Two-stage acceleration/ deceleration switching speed	Asymmetrical acceleration/ deceleration acceleration time	Asymmetrical acceleration/ deceleration bias speed	Current position setting
OWxxxx+7		0	Second-stage acceleration/ deceleration time	Asymmetrical acceleration/ deceleration deceleration time		

* Output coils PRMn0 to PRMn3 (parameter number selectors) specify the parameters.

6.6.5 Input Relays

Input relays are status signals sent from the Pulse Output Module to the host controller.

The following table lists the input relays.

Address	Channel	Bit 7	Bit 6	Bit 5	Bit 4	Bit 3	Bit 2	Bit 1	Bit 0	
IWxxxxx+2	1	Lower byte	–	–	PNACK1	PACK1	–	MONSEL1	–	RDY1
		Upper byte	IN1	ZRN1	TIMING1	OVER1	–	ZRN1L	JOG1L	MOV1L
IWxxxxx+3	2	Lower byte	–	–	PNACK2	PACK2	–	MONSEL2	–	RDY2
		Upper byte	IN2	ZRN2	TIMING2	OVER2	–	ZRN2L	JOG2L	MOV2L

The following table summarizes the function of each signal.

Byte	Bit No.	Symbol	Signal Name	Details
Lower byte	0	RDYn	Ready	Indicates the results of the Module's self-diagnostic tests. • Normal: ON • Abnormal: OFF
	2	MONSELn	Monitor Parameters	Indicates that the parameters are being monitored.
	4	PACKn	Parameter settings normal	Indicates that the setting operation was completed normally. The "PACK" signal stays ON while the set reference is ON.
	5	PNACKn	Parameter setting error	Indicates that an error occurred in the setting operation. The "PNACK" signal stays ON while the set reference is ON.
Upper byte	0	MOVnL	Positioning	Indicates that the positioning operation is being performed.
	1	JOGnL	JOG operation	Indicates that a JOG operation is being performed.
	2	ZRNnL	Zero point return	Indicates that a zero point return operation is being performed.
	4	OVERn	Overheat input status	Indicates the status of the external overheat input terminal.
	5	TIMINGn	Magnetic excitation timing input status	Indicates the status of the external magnetic excitation timing input terminal.
	6	ZRNn	Zero point signal input status	Indicates the status of the external zero point signal input terminal.
	7	INn	General-purpose input status	Indicates the status of the external general-purpose input terminal.

Note: The letter "n" at the end of the signals denotes channel number 1 or 2.

6.6.6 Input Registers

Input registers are used when monitoring various kinds of information from the Pulse Output Module. Input registers are used for monitoring the following information:

- Current Position
- Parameter Settings

IMPORTANT

The same input registers are used to monitor different data at different times, so be careful that the monitor signals do not overlap.

The input registers are listed in the following table.

Register Address	Channel	Monitored Data						
		Current Position	Alarm	Parameter Number *				
				01	02	03	04	05
IWxxxxx+4	1	Current position (lower bytes)	Alarm code	Output mode	JOG speed	Zero point return speed	Zero point return approach speed	Positioning speed
IWxxxxx+5			Alarm history	Used by system				
IWxxxxx+6	2	Current position (upper bytes)	Alarm code	-	JOG accel/ decel time	Zero point return accel/ decel time	Zero point return creep speed	Positioning accel/ decel time
IWxxxxx+7			Alarm history					

* Output coils PRMn0 to PRMn3 (parameter number selectors) specify the parameters.

6.6.7 Monitoring Data

(1) Overview

The following three kinds of data in the Pulse Output Module can be monitored.

- Current position
- Alarm status
- Parameter settings

Input relays and output coils are used together to monitor data. Eight consecutive bytes of input registers are used to monitor various types of data sent from the Pulse Output Module to the host controller.

The input registers used for monitoring data are listed in the following table.



The register numbers are as follows:

- Channel 1: 1st byte to 4th byte
- Channel 2: 5th byte to 8th byte

(2) Monitoring the Current Position

To monitor the current position, turn OFF the MONSELn output coil.

- MONSELn: OFF

Monitored Data	Channel 1	Channel 2	Data
Current Position	1st byte	5th byte	Current position (lower word, lower byte)
	2nd byte	6th byte	Current position (lower word, upper byte)
	3rd byte	7th byte	Current position (upper word, lower byte)
	4th byte	8th byte	Current position (upper word, upper byte)

(3) Monitoring the Alarm

To monitor the Pulse Output Module alarms, set the MONSELn, PRMn0 to PRMn3, and PSETn output coils as follows:

- MONSELn: ON
- PRMn0 to PRMn3: OFF
- PSETn: ON

Monitored Data	Channel 1	Channel 2	Data
Current Position	1st byte	5th byte	Alarm current value
	2nd byte	6th byte	Alarm history
	3rd byte	7th byte	Alarm history
	4th byte	8th byte	Alarm history

The following table shows the Module's alarm codes.

Code	Details	Time when Alarm Is Detected
00	Normal status	–
01	Incorrect parameter value	When parameters are set
02	Overheat input	Each scan
03	Move reference when output current is OFF.	When the move reference is specified
04	Positioning target position error	When the positioning reference is specified (out of the \pm 32-bit range)
05	Communication error during pulse output	When the communication error occurs

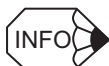

- When an alarm is reset, the current alarm code is copied to the alarm history before it is reset to 0. Consequently, the alarm code remains in the alarm history even after the alarm is reset.
- The alarm history will not be updated if the new alarm code is the same as the previous alarm code.

(4) Monitoring Parameters

To monitor the Pulse Output Module's parameter settings, set the MONSELn, PRMn0 to PRMn3, and PSETn output coils as follows:

- MONSELn: ON
- PRMn0 to PRMn3: Set the desired parameter number
- PSETn: ON



The register numbers are as follows:

- Channel 1: 1st byte to 4th byte
- Channel 2: 5th byte to 8th byte

Monitored Data	Input Registers																			
	Parameter No.	PRMn3	PRMn2	PRMn1	PRMn0															
Output Mode	1	OFF	OFF	OFF	ON															
	<table border="1"> <thead> <tr> <th>Channel 1</th> <th>Channel 2</th> <th>Data</th> </tr> </thead> <tbody> <tr> <td>1st byte</td> <td>5th byte</td> <td>Output mode</td> </tr> <tr> <td>2nd byte</td> <td>6th byte</td> <td>Used by system.</td> </tr> <tr> <td>3rd byte</td> <td>7th byte</td> <td>Not used.</td> </tr> <tr> <td>4th byte</td> <td>8th byte</td> <td>Not used.</td> </tr> </tbody> </table>					Channel 1	Channel 2	Data	1st byte	5th byte	Output mode	2nd byte	6th byte	Used by system.	3rd byte	7th byte	Not used.	4th byte	8th byte	Not used.
	Channel 1	Channel 2	Data																	
	1st byte	5th byte	Output mode																	
	2nd byte	6th byte	Used by system.																	
	3rd byte	7th byte	Not used.																	
4th byte	8th byte	Not used.																		
<table border="1"> <thead> <tr> <th>Channel 1</th> <th>Channel 2</th> <th>Data</th> </tr> </thead> <tbody> <tr> <td>1st byte</td> <td>5th byte</td> <td>JOG speed (lower byte)</td> </tr> <tr> <td>2nd byte</td> <td>6th byte</td> <td>JOG speed (upper byte)</td> </tr> <tr> <td>3rd byte</td> <td>7th byte</td> <td>JOG acceleration/deceleration time (lower byte)</td> </tr> <tr> <td>4th byte</td> <td>8th byte</td> <td>JOG acceleration/deceleration time (upper byte)</td> </tr> </tbody> </table>					Channel 1	Channel 2	Data	1st byte	5th byte	JOG speed (lower byte)	2nd byte	6th byte	JOG speed (upper byte)	3rd byte	7th byte	JOG acceleration/deceleration time (lower byte)	4th byte	8th byte	JOG acceleration/deceleration time (upper byte)	
Channel 1	Channel 2	Data																		
1st byte	5th byte	JOG speed (lower byte)																		
2nd byte	6th byte	JOG speed (upper byte)																		
3rd byte	7th byte	JOG acceleration/deceleration time (lower byte)																		
4th byte	8th byte	JOG acceleration/deceleration time (upper byte)																		
<table border="1"> <thead> <tr> <th>Channel 1</th> <th>Channel 2</th> <th>Data</th> </tr> </thead> <tbody> <tr> <td>1st byte</td> <td>5th byte</td> <td>Zero point return speed (lower byte)</td> </tr> <tr> <td>2nd byte</td> <td>6th byte</td> <td>Zero point return speed (upper byte)</td> </tr> <tr> <td>3rd byte</td> <td>7th byte</td> <td>Zero point return acceleration/deceleration time (lower byte)</td> </tr> <tr> <td>4th byte</td> <td>8th byte</td> <td>Zero point return acceleration/deceleration time (upper byte)</td> </tr> </tbody> </table>					Channel 1	Channel 2	Data	1st byte	5th byte	Zero point return speed (lower byte)	2nd byte	6th byte	Zero point return speed (upper byte)	3rd byte	7th byte	Zero point return acceleration/deceleration time (lower byte)	4th byte	8th byte	Zero point return acceleration/deceleration time (upper byte)	
Channel 1	Channel 2	Data																		
1st byte	5th byte	Zero point return speed (lower byte)																		
2nd byte	6th byte	Zero point return speed (upper byte)																		
3rd byte	7th byte	Zero point return acceleration/deceleration time (lower byte)																		
4th byte	8th byte	Zero point return acceleration/deceleration time (upper byte)																		
<table border="1"> <thead> <tr> <th>Channel 1</th> <th>Channel 2</th> <th>Data</th> </tr> </thead> <tbody> <tr> <td>1st byte</td> <td>5th byte</td> <td>Zero point return speed (lower byte)</td> </tr> <tr> <td>2nd byte</td> <td>6th byte</td> <td>Zero point return speed (upper byte)</td> </tr> <tr> <td>3rd byte</td> <td>7th byte</td> <td>Zero point return acceleration/deceleration time (lower byte)</td> </tr> <tr> <td>4th byte</td> <td>8th byte</td> <td>Zero point return acceleration/deceleration time (upper byte)</td> </tr> </tbody> </table>					Channel 1	Channel 2	Data	1st byte	5th byte	Zero point return speed (lower byte)	2nd byte	6th byte	Zero point return speed (upper byte)	3rd byte	7th byte	Zero point return acceleration/deceleration time (lower byte)	4th byte	8th byte	Zero point return acceleration/deceleration time (upper byte)	
Channel 1	Channel 2	Data																		
1st byte	5th byte	Zero point return speed (lower byte)																		
2nd byte	6th byte	Zero point return speed (upper byte)																		
3rd byte	7th byte	Zero point return acceleration/deceleration time (lower byte)																		
4th byte	8th byte	Zero point return acceleration/deceleration time (upper byte)																		
Jog Speed and Jog Accel Time	2	OFF	OFF	ON	OFF															
	<table border="1"> <thead> <tr> <th>Channel 1</th> <th>Channel 2</th> <th>Data</th> </tr> </thead> <tbody> <tr> <td>1st byte</td> <td>5th byte</td> <td>JOG speed (lower byte)</td> </tr> <tr> <td>2nd byte</td> <td>6th byte</td> <td>JOG speed (upper byte)</td> </tr> <tr> <td>3rd byte</td> <td>7th byte</td> <td>JOG acceleration/deceleration time (lower byte)</td> </tr> <tr> <td>4th byte</td> <td>8th byte</td> <td>JOG acceleration/deceleration time (upper byte)</td> </tr> </tbody> </table>					Channel 1	Channel 2	Data	1st byte	5th byte	JOG speed (lower byte)	2nd byte	6th byte	JOG speed (upper byte)	3rd byte	7th byte	JOG acceleration/deceleration time (lower byte)	4th byte	8th byte	JOG acceleration/deceleration time (upper byte)
Channel 1	Channel 2	Data																		
1st byte	5th byte	JOG speed (lower byte)																		
2nd byte	6th byte	JOG speed (upper byte)																		
3rd byte	7th byte	JOG acceleration/deceleration time (lower byte)																		
4th byte	8th byte	JOG acceleration/deceleration time (upper byte)																		
Zero Point Return Speed and Zero Point Return Accel/Decel Time	3	OFF	OFF	ON	ON															
	<table border="1"> <thead> <tr> <th>Channel 1</th> <th>Channel 2</th> <th>Data</th> </tr> </thead> <tbody> <tr> <td>1st byte</td> <td>5th byte</td> <td>Zero point return speed (lower byte)</td> </tr> <tr> <td>2nd byte</td> <td>6th byte</td> <td>Zero point return speed (upper byte)</td> </tr> <tr> <td>3rd byte</td> <td>7th byte</td> <td>Zero point return acceleration/deceleration time (lower byte)</td> </tr> <tr> <td>4th byte</td> <td>8th byte</td> <td>Zero point return acceleration/deceleration time (upper byte)</td> </tr> </tbody> </table>					Channel 1	Channel 2	Data	1st byte	5th byte	Zero point return speed (lower byte)	2nd byte	6th byte	Zero point return speed (upper byte)	3rd byte	7th byte	Zero point return acceleration/deceleration time (lower byte)	4th byte	8th byte	Zero point return acceleration/deceleration time (upper byte)
	Channel 1	Channel 2	Data																	
	1st byte	5th byte	Zero point return speed (lower byte)																	
	2nd byte	6th byte	Zero point return speed (upper byte)																	
	3rd byte	7th byte	Zero point return acceleration/deceleration time (lower byte)																	
4th byte	8th byte	Zero point return acceleration/deceleration time (upper byte)																		
<table border="1"> <thead> <tr> <th>Channel 1</th> <th>Channel 2</th> <th>Data</th> </tr> </thead> <tbody> <tr> <td>1st byte</td> <td>5th byte</td> <td>Zero point return speed (lower byte)</td> </tr> <tr> <td>2nd byte</td> <td>6th byte</td> <td>Zero point return speed (upper byte)</td> </tr> <tr> <td>3rd byte</td> <td>7th byte</td> <td>Zero point return acceleration/deceleration time (lower byte)</td> </tr> <tr> <td>4th byte</td> <td>8th byte</td> <td>Zero point return acceleration/deceleration time (upper byte)</td> </tr> </tbody> </table>					Channel 1	Channel 2	Data	1st byte	5th byte	Zero point return speed (lower byte)	2nd byte	6th byte	Zero point return speed (upper byte)	3rd byte	7th byte	Zero point return acceleration/deceleration time (lower byte)	4th byte	8th byte	Zero point return acceleration/deceleration time (upper byte)	
Channel 1	Channel 2	Data																		
1st byte	5th byte	Zero point return speed (lower byte)																		
2nd byte	6th byte	Zero point return speed (upper byte)																		
3rd byte	7th byte	Zero point return acceleration/deceleration time (lower byte)																		
4th byte	8th byte	Zero point return acceleration/deceleration time (upper byte)																		
<table border="1"> <thead> <tr> <th>Channel 1</th> <th>Channel 2</th> <th>Data</th> </tr> </thead> <tbody> <tr> <td>1st byte</td> <td>5th byte</td> <td>Zero point return speed (lower byte)</td> </tr> <tr> <td>2nd byte</td> <td>6th byte</td> <td>Zero point return speed (upper byte)</td> </tr> <tr> <td>3rd byte</td> <td>7th byte</td> <td>Zero point return acceleration/deceleration time (lower byte)</td> </tr> <tr> <td>4th byte</td> <td>8th byte</td> <td>Zero point return acceleration/deceleration time (upper byte)</td> </tr> </tbody> </table>					Channel 1	Channel 2	Data	1st byte	5th byte	Zero point return speed (lower byte)	2nd byte	6th byte	Zero point return speed (upper byte)	3rd byte	7th byte	Zero point return acceleration/deceleration time (lower byte)	4th byte	8th byte	Zero point return acceleration/deceleration time (upper byte)	
Channel 1	Channel 2	Data																		
1st byte	5th byte	Zero point return speed (lower byte)																		
2nd byte	6th byte	Zero point return speed (upper byte)																		
3rd byte	7th byte	Zero point return acceleration/deceleration time (lower byte)																		
4th byte	8th byte	Zero point return acceleration/deceleration time (upper byte)																		
<table border="1"> <thead> <tr> <th>Channel 1</th> <th>Channel 2</th> <th>Data</th> </tr> </thead> <tbody> <tr> <td>1st byte</td> <td>5th byte</td> <td>Zero point return speed (lower byte)</td> </tr> <tr> <td>2nd byte</td> <td>6th byte</td> <td>Zero point return speed (upper byte)</td> </tr> <tr> <td>3rd byte</td> <td>7th byte</td> <td>Zero point return acceleration/deceleration time (lower byte)</td> </tr> <tr> <td>4th byte</td> <td>8th byte</td> <td>Zero point return acceleration/deceleration time (upper byte)</td> </tr> </tbody> </table>					Channel 1	Channel 2	Data	1st byte	5th byte	Zero point return speed (lower byte)	2nd byte	6th byte	Zero point return speed (upper byte)	3rd byte	7th byte	Zero point return acceleration/deceleration time (lower byte)	4th byte	8th byte	Zero point return acceleration/deceleration time (upper byte)	
Channel 1	Channel 2	Data																		
1st byte	5th byte	Zero point return speed (lower byte)																		
2nd byte	6th byte	Zero point return speed (upper byte)																		
3rd byte	7th byte	Zero point return acceleration/deceleration time (lower byte)																		
4th byte	8th byte	Zero point return acceleration/deceleration time (upper byte)																		

(cont'd)

Monitored Data	Input Registers																			
	Parameter No.	PRMn3	PRMn2	PRMn1	PRMn0															
Zero Point Return Approach Speed and Zero Point Return Creep Speed	4	OFF	ON	OFF	ON															
	<table border="1"> <thead> <tr> <th>Channel 1</th> <th>Channel 2</th> <th>Data</th> </tr> </thead> <tbody> <tr> <td>1st byte</td> <td>5th byte</td> <td>Zero point return approach speed (lower byte)</td> </tr> <tr> <td>2nd byte</td> <td>6th byte</td> <td>Zero point return approach speed (upper byte)</td> </tr> <tr> <td>3rd byte</td> <td>7th byte</td> <td>Zero point return creep speed (lower byte)</td> </tr> <tr> <td>4th byte</td> <td>8th byte</td> <td>Zero point return creep speed (upper byte)</td> </tr> </tbody> </table>					Channel 1	Channel 2	Data	1st byte	5th byte	Zero point return approach speed (lower byte)	2nd byte	6th byte	Zero point return approach speed (upper byte)	3rd byte	7th byte	Zero point return creep speed (lower byte)	4th byte	8th byte	Zero point return creep speed (upper byte)
	Channel 1	Channel 2	Data																	
	1st byte	5th byte	Zero point return approach speed (lower byte)																	
	2nd byte	6th byte	Zero point return approach speed (upper byte)																	
	3rd byte	7th byte	Zero point return creep speed (lower byte)																	
4th byte	8th byte	Zero point return creep speed (upper byte)																		
<table border="1"> <thead> <tr> <th>Channel 1</th> <th>Channel 2</th> <th>Data</th> </tr> </thead> <tbody> <tr> <td>1st byte</td> <td>5th byte</td> <td>Positioning speed (lower byte)</td> </tr> <tr> <td>2nd byte</td> <td>6th byte</td> <td>Positioning speed (upper byte)</td> </tr> <tr> <td>3rd byte</td> <td>7th byte</td> <td>Positioning acceleration/deceleration time (lower byte)</td> </tr> <tr> <td>4th byte</td> <td>8th byte</td> <td>Positioning acceleration/deceleration time (upper byte)</td> </tr> </tbody> </table>					Channel 1	Channel 2	Data	1st byte	5th byte	Positioning speed (lower byte)	2nd byte	6th byte	Positioning speed (upper byte)	3rd byte	7th byte	Positioning acceleration/deceleration time (lower byte)	4th byte	8th byte	Positioning acceleration/deceleration time (upper byte)	
Channel 1	Channel 2	Data																		
1st byte	5th byte	Positioning speed (lower byte)																		
2nd byte	6th byte	Positioning speed (upper byte)																		
3rd byte	7th byte	Positioning acceleration/deceleration time (lower byte)																		
4th byte	8th byte	Positioning acceleration/deceleration time (upper byte)																		
<table border="1"> <thead> <tr> <th>Channel 1</th> <th>Channel 2</th> <th>Data</th> </tr> </thead> <tbody> <tr> <td>1st byte</td> <td>5th byte</td> <td>Acceleration/deceleration mode</td> </tr> <tr> <td>2nd byte</td> <td>6th byte</td> <td>Not used.</td> </tr> <tr> <td>3rd byte</td> <td>7th byte</td> <td>Not used.</td> </tr> <tr> <td>4th byte</td> <td>8th byte</td> <td>Not used.</td> </tr> </tbody> </table>					Channel 1	Channel 2	Data	1st byte	5th byte	Acceleration/deceleration mode	2nd byte	6th byte	Not used.	3rd byte	7th byte	Not used.	4th byte	8th byte	Not used.	
Channel 1	Channel 2	Data																		
1st byte	5th byte	Acceleration/deceleration mode																		
2nd byte	6th byte	Not used.																		
3rd byte	7th byte	Not used.																		
4th byte	8th byte	Not used.																		
<table border="1"> <thead> <tr> <th>Channel 1</th> <th>Channel 2</th> <th>Data</th> </tr> </thead> <tbody> <tr> <td>1st byte</td> <td>5th byte</td> <td>Two-stage acceleration/deceleration switching speed (lower byte)</td> </tr> <tr> <td>2nd byte</td> <td>6th byte</td> <td>Two-stage acceleration/deceleration switching speed (upper byte)</td> </tr> <tr> <td>3rd byte</td> <td>7th byte</td> <td>Second-stage acceleration/deceleration time (lower byte)</td> </tr> <tr> <td>4th byte</td> <td>8th byte</td> <td>Second-stage acceleration/deceleration time (upper byte)</td> </tr> </tbody> </table>					Channel 1	Channel 2	Data	1st byte	5th byte	Two-stage acceleration/deceleration switching speed (lower byte)	2nd byte	6th byte	Two-stage acceleration/deceleration switching speed (upper byte)	3rd byte	7th byte	Second-stage acceleration/deceleration time (lower byte)	4th byte	8th byte	Second-stage acceleration/deceleration time (upper byte)	
Channel 1	Channel 2	Data																		
1st byte	5th byte	Two-stage acceleration/deceleration switching speed (lower byte)																		
2nd byte	6th byte	Two-stage acceleration/deceleration switching speed (upper byte)																		
3rd byte	7th byte	Second-stage acceleration/deceleration time (lower byte)																		
4th byte	8th byte	Second-stage acceleration/deceleration time (upper byte)																		
Positioning Speed and Positioning Accel/Decel Time	5	OFF	ON	OFF	ON															
	<table border="1"> <thead> <tr> <th>Channel 1</th> <th>Channel 2</th> <th>Data</th> </tr> </thead> <tbody> <tr> <td>1st byte</td> <td>5th byte</td> <td>Positioning speed (lower byte)</td> </tr> <tr> <td>2nd byte</td> <td>6th byte</td> <td>Positioning speed (upper byte)</td> </tr> <tr> <td>3rd byte</td> <td>7th byte</td> <td>Positioning acceleration/deceleration time (lower byte)</td> </tr> <tr> <td>4th byte</td> <td>8th byte</td> <td>Positioning acceleration/deceleration time (upper byte)</td> </tr> </tbody> </table>					Channel 1	Channel 2	Data	1st byte	5th byte	Positioning speed (lower byte)	2nd byte	6th byte	Positioning speed (upper byte)	3rd byte	7th byte	Positioning acceleration/deceleration time (lower byte)	4th byte	8th byte	Positioning acceleration/deceleration time (upper byte)
Channel 1	Channel 2	Data																		
1st byte	5th byte	Positioning speed (lower byte)																		
2nd byte	6th byte	Positioning speed (upper byte)																		
3rd byte	7th byte	Positioning acceleration/deceleration time (lower byte)																		
4th byte	8th byte	Positioning acceleration/deceleration time (upper byte)																		
Acceleration/ Deceleration Mode	8	ON	OFF	OFF	OFF															
	<table border="1"> <thead> <tr> <th>Channel 1</th> <th>Channel 2</th> <th>Data</th> </tr> </thead> <tbody> <tr> <td>1st byte</td> <td>5th byte</td> <td>Acceleration/deceleration mode</td> </tr> <tr> <td>2nd byte</td> <td>6th byte</td> <td>Not used.</td> </tr> <tr> <td>3rd byte</td> <td>7th byte</td> <td>Not used.</td> </tr> <tr> <td>4th byte</td> <td>8th byte</td> <td>Not used.</td> </tr> </tbody> </table>					Channel 1	Channel 2	Data	1st byte	5th byte	Acceleration/deceleration mode	2nd byte	6th byte	Not used.	3rd byte	7th byte	Not used.	4th byte	8th byte	Not used.
Channel 1	Channel 2	Data																		
1st byte	5th byte	Acceleration/deceleration mode																		
2nd byte	6th byte	Not used.																		
3rd byte	7th byte	Not used.																		
4th byte	8th byte	Not used.																		
Two-stage Accel/Decel Switching Speed and Second-stage Accel/Decel Time	9	ON	OFF	OFF	ON															
	<table border="1"> <thead> <tr> <th>Channel 1</th> <th>Channel 2</th> <th>Data</th> </tr> </thead> <tbody> <tr> <td>1st byte</td> <td>5th byte</td> <td>Two-stage acceleration/deceleration switching speed (lower byte)</td> </tr> <tr> <td>2nd byte</td> <td>6th byte</td> <td>Two-stage acceleration/deceleration switching speed (upper byte)</td> </tr> <tr> <td>3rd byte</td> <td>7th byte</td> <td>Second-stage acceleration/deceleration time (lower byte)</td> </tr> <tr> <td>4th byte</td> <td>8th byte</td> <td>Second-stage acceleration/deceleration time (upper byte)</td> </tr> </tbody> </table>					Channel 1	Channel 2	Data	1st byte	5th byte	Two-stage acceleration/deceleration switching speed (lower byte)	2nd byte	6th byte	Two-stage acceleration/deceleration switching speed (upper byte)	3rd byte	7th byte	Second-stage acceleration/deceleration time (lower byte)	4th byte	8th byte	Second-stage acceleration/deceleration time (upper byte)
Channel 1	Channel 2	Data																		
1st byte	5th byte	Two-stage acceleration/deceleration switching speed (lower byte)																		
2nd byte	6th byte	Two-stage acceleration/deceleration switching speed (upper byte)																		
3rd byte	7th byte	Second-stage acceleration/deceleration time (lower byte)																		
4th byte	8th byte	Second-stage acceleration/deceleration time (upper byte)																		

(cont'd)

Monitored Data	Input Registers																			
	Parameter No.	PRMn3	PRMn2	PRMn1	PRMn0															
Asymmetrical Acceleration/ Deceleration Acceleration and Deceleration Times	10	ON	OFF	ON	OFF															
	<table border="1"> <thead> <tr> <th>Channel 1</th> <th>Channel 2</th> <th>Data</th> </tr> </thead> <tbody> <tr> <td>1st byte</td> <td>5th byte</td> <td>Asymmetrical acceleration/deceleration acceleration time (lower byte)</td> </tr> <tr> <td>2nd byte</td> <td>6th byte</td> <td>Asymmetrical acceleration/deceleration acceleration time (upper byte)</td> </tr> <tr> <td>3rd byte</td> <td>7th byte</td> <td>Asymmetrical acceleration/deceleration deceleration time (lower byte)</td> </tr> <tr> <td>4th byte</td> <td>8th byte</td> <td>Asymmetrical acceleration/deceleration deceleration time (upper byte)</td> </tr> </tbody> </table>					Channel 1	Channel 2	Data	1st byte	5th byte	Asymmetrical acceleration/deceleration acceleration time (lower byte)	2nd byte	6th byte	Asymmetrical acceleration/deceleration acceleration time (upper byte)	3rd byte	7th byte	Asymmetrical acceleration/deceleration deceleration time (lower byte)	4th byte	8th byte	Asymmetrical acceleration/deceleration deceleration time (upper byte)
	Channel 1	Channel 2	Data																	
	1st byte	5th byte	Asymmetrical acceleration/deceleration acceleration time (lower byte)																	
	2nd byte	6th byte	Asymmetrical acceleration/deceleration acceleration time (upper byte)																	
	3rd byte	7th byte	Asymmetrical acceleration/deceleration deceleration time (lower byte)																	
	4th byte	8th byte	Asymmetrical acceleration/deceleration deceleration time (upper byte)																	
Asymmetrical Acceleration/ Deceleration Bias Speed	11	ON	OFF	ON	ON															
	<table border="1"> <thead> <tr> <th>Channel 1</th> <th>Channel 2</th> <th>Data</th> </tr> </thead> <tbody> <tr> <td>1st byte</td> <td>5th byte</td> <td>Asymmetrical acceleration/deceleration bias speed (lower byte)</td> </tr> <tr> <td>2nd byte</td> <td>6th byte</td> <td>Asymmetrical acceleration/deceleration bias speed (upper byte)</td> </tr> <tr> <td>3rd byte</td> <td>7th byte</td> <td>Not used.</td> </tr> <tr> <td>4th byte</td> <td>8th byte</td> <td>Not used.</td> </tr> </tbody> </table>					Channel 1	Channel 2	Data	1st byte	5th byte	Asymmetrical acceleration/deceleration bias speed (lower byte)	2nd byte	6th byte	Asymmetrical acceleration/deceleration bias speed (upper byte)	3rd byte	7th byte	Not used.	4th byte	8th byte	Not used.
	Channel 1	Channel 2	Data																	
	1st byte	5th byte	Asymmetrical acceleration/deceleration bias speed (lower byte)																	
	2nd byte	6th byte	Asymmetrical acceleration/deceleration bias speed (upper byte)																	
	3rd byte	7th byte	Not used.																	
	4th byte	8th byte	Not used.																	

6.7 Module Operation

6.7.1 Operation Flowchart

The following flowchart outlines the flow of operation for the Pulse Output Module.

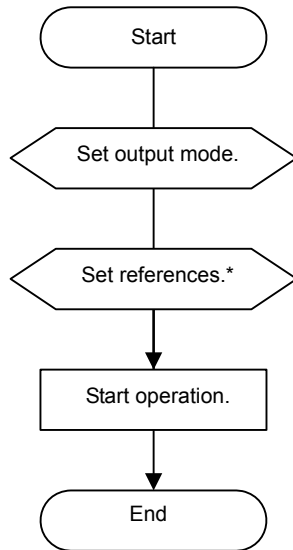

* Set output coils and output registers.

6.7.2 Positioning Function

(1) Overview

When the MOVn signal turns ON, pulses are output to move from the current position to the target position at the set speed.

The speed and acceleration/deceleration time are set in the parameters.

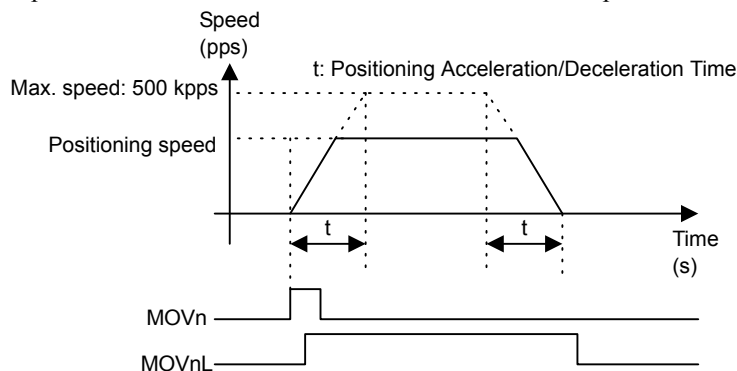

(2) Related References

Use the following I/O data to execute instructions.

(a) Output Coils

Symbol	Signal Name	Details
MOVn *	Positioning reference	This reference starts the positioning operation. The signal operates when it goes from OFF to ON.

* The letter "n" denotes the channel number 1 or 2.

(b) Parameters

Parameter No.	Parameter No. Setting				Name	Setting Range	Units	Default Setting
	PRMn 3	PRMn 2	PRMn 1	PRMn 0				
05	OFF	ON	OFF	ON	Positioning speed	1 to 50000	10 pps	500
					Positioning Acceleration/ Deceleration Time	50 to 5000	100 ms	100

(c) Input Relays

Symbol	Signal Name	Details
MOVnL *	Positioning	Indicates that the positioning operation is being performed.

* The letter "n" denotes channel number 1 or 2.

(d) Output Register Configuration

Register No.		Details
Channel 1	Channel 2	
1st byte	5th byte	Positioning speed (lower byte)
2nd byte	6th byte	Positioning speed (upper byte)
3rd byte	7th byte	Positioning acceleration/deceleration time (lower byte)
4th byte	8th byte	Positioning acceleration/deceleration time (upper byte)

(3) Operation

Use the following procedure to perform positioning operations.

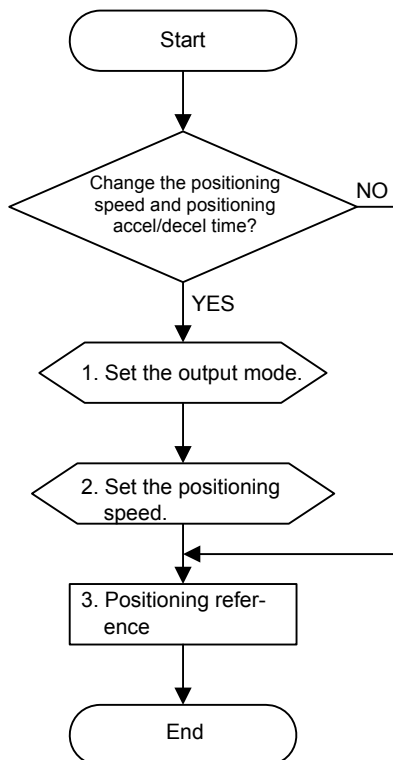

Once the output mode (step 1) and positioning speed (step 2) have been set, it is not necessary to set them again until there are changes.

1. Selecting the Output Mode

- Set the parameter number to 1 in the Parameter Number Selector output coils (PRMn0 to PRMn3).
- Set the output mode in the lower byte of output register OWxxxx+4 (for channel 1) or OWxxxx+6 (for channel 2).

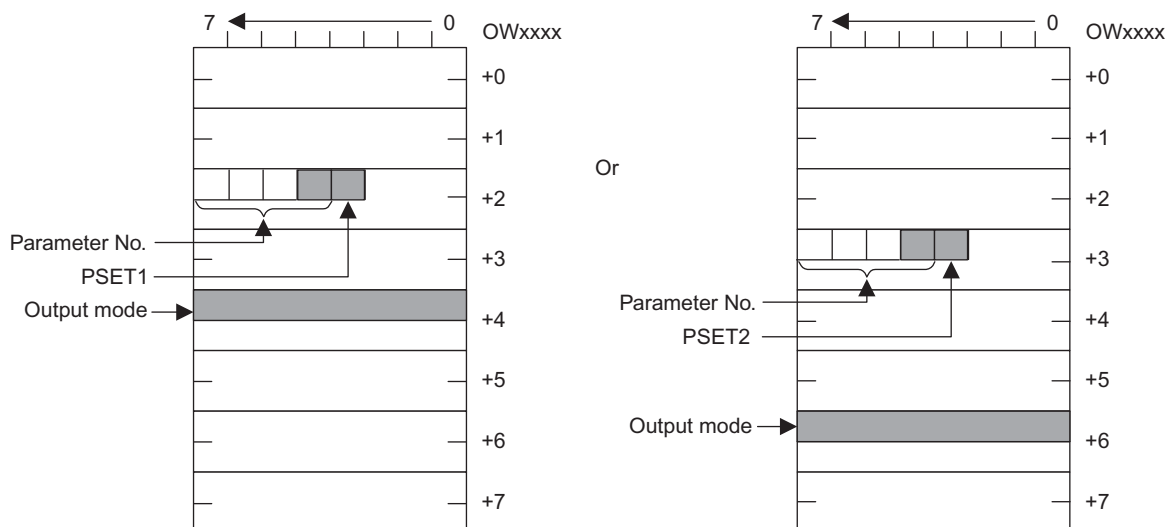

- Turn the Parameter Set/Monitor Selector output coil (PSETn) from OFF to ON.

2. Setting the positioning speed and positioning acceleration/deceleration time

- a) Set the parameter number to 5 in the Parameter Number Selector output coils (PRMn0 to PRMn3).
- b) Set the positioning speed in the lower byte of output register OWxxxx+4 (for channel 1) or OWxxxx+6 (for channel 2).
Set the positioning acceleration/deceleration time in the lower byte of output register OWxxxx+5 (for channel 1) or OWxxxx+7 (for channel 2).

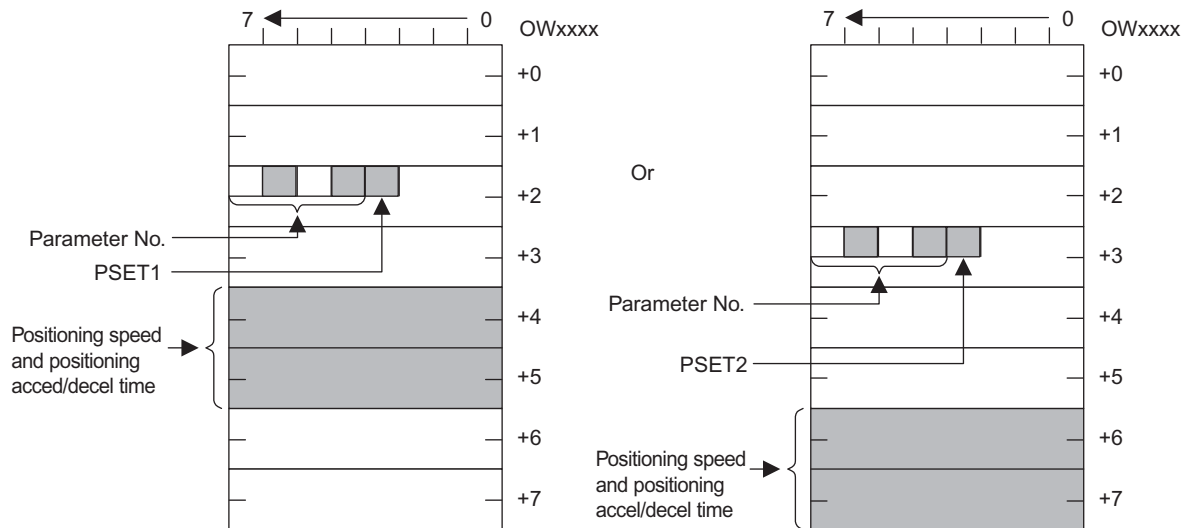

- c) Turn the Parameter Set/Monitor Selector output coil (PSETn) from OFF to ON.

3. Positioning Reference

- a) Set the positioning target position in output registers OWxxxx+4 and OWxxxx+5 (for channel 1) or OWxxxx+6 and OWxxxx+7 (for channel 2).

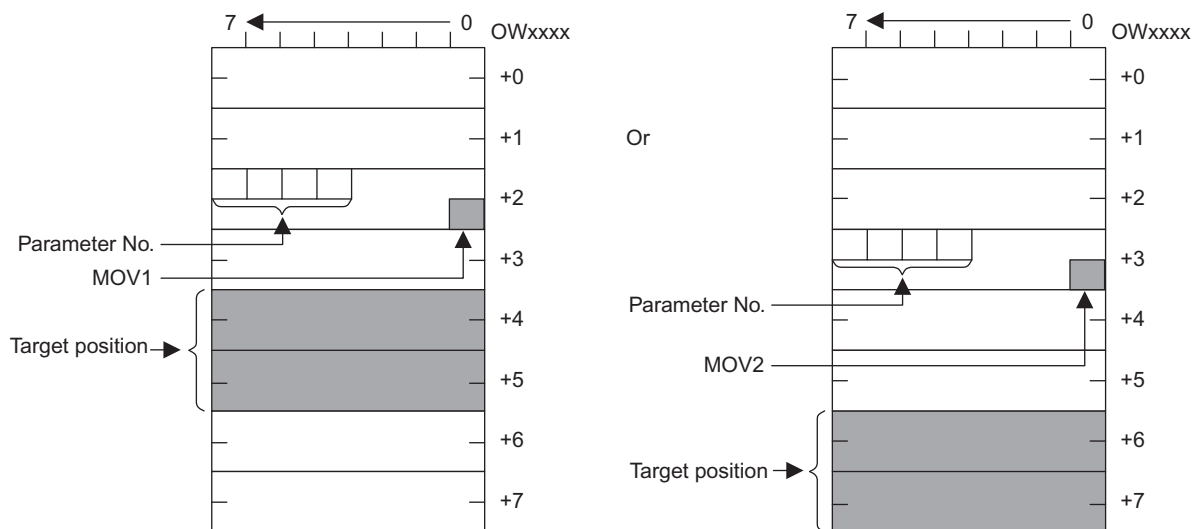

- b) Turn OFF the following output coils:

- Cancel (CANn)
- JOG Operation (JOGn)
- Zero Point Return (ZRNn)

- c) Turn the Positioning Reference output coil (MOVn) from OFF to ON.

- d) Cancel

To cancel positioning, turn the Cancel output coil (CANn) from OFF to ON during positioning.

4. Positioning completed.

(4) Timing Chart

The following timing charts show the operation of the positioning function.

Keep MOVn ON until MOVnL goes from OFF to ON. Turn MOVn OFF after MOVnL has gone ON.

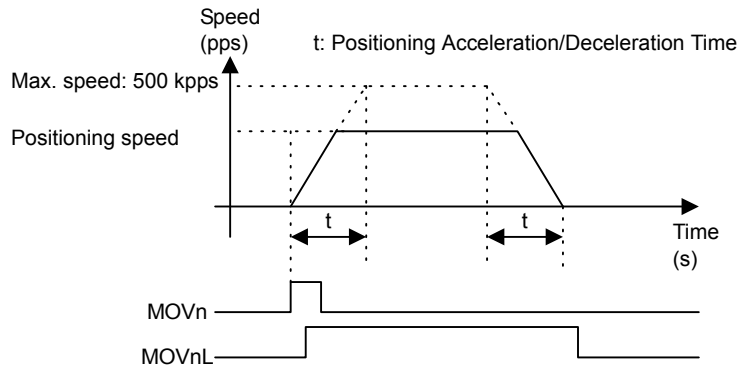

The following timing chart shows the cancel operation.

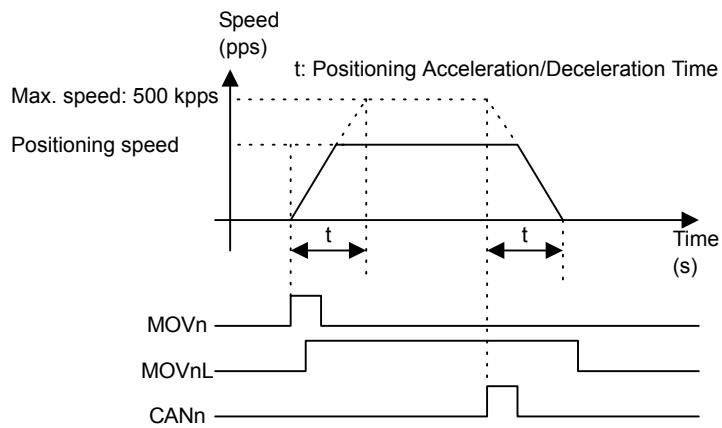

(5) Sample Program

A sample positioning program is shown below:

In the following example, outputs are allocated to OW0030 to OW0037 while inputs are allocated to IW0020 to IW0027.

```

MPS101 "1"
    "Program for CH1;
    ;
    OW0032=2000h;      "Reset output coils
    OB00324=1;        "Set positioning parameters
    OB00326=1;

    OW0034=MW30020;   "Positioning speed
    OW0035=MW30021;   "Positioning accel/decel time
    ;
    OB00323=1;        "ON to set parameters
    IOW IB00224==1;   "Parameter settings completed

    OB00323=0;        "OFF to stop setting parameters
    ;
    OB00324=0;
    OB00326=0;
    ;
    ;
    TIM t4;
    OL0034=ML30022;   "Set target position (absolute position)

    OB00328==1;       "Start positioning
    IOW IB00228==1;   ;
    OB00328=0;
    IOW IB00228==0;   "Wait to reach target position
    OL0034=0;         "Reset target position to 0
    ret;

```

6.7.3 Jog Operation

(1) Overview

Outputs pulses at the set speed and direction while the JOGn signal is ON.

The acceleration/deceleration time is set in the parameters.

The JOG speed and JOG direction are specified by the REVn signal.

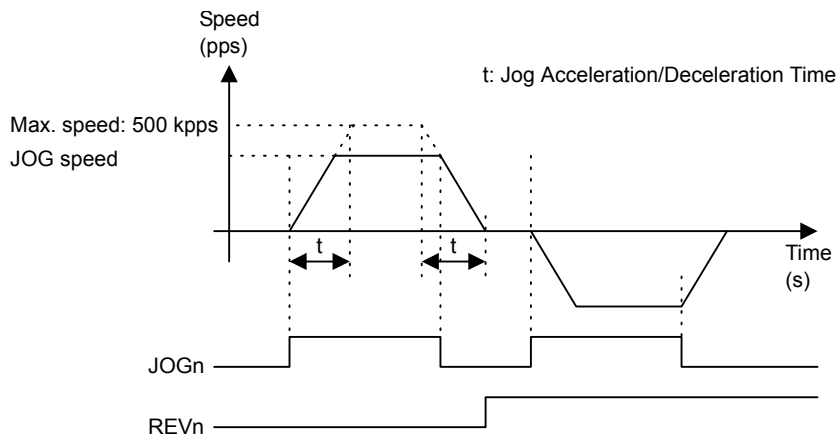

(2) Related References

(a) Output Coils

Use the following I/O data to execute instructions.

Symbol	Signal Name	Details
JOGn *	JOG Operation	This reference controls JOG operation. JOG operation stops when this signal is OFF and operates when it is ON.

* The letter "n" denotes the channel number 1 or 2.

(b) Parameters

Parameter No.	Parameter No. Setting				Name	Setting Range	Units	Default Setting
	PRMn 3	PRMn 2	PRMn 1	PRMn 0				
02	OFF	OFF	ON	OFF	JOG speed	1 to 50000	10 pps	500
					JOG acceleration/deceleration time	50 to 5000	100 ms	100

(c) Input Relays

Symbol	Signal Name	Details
JOGnL *	JOG operation	Indicates that a JOG operation is being performed.

* The letter "n" denotes the channel number 1 or 2.

(d) Command Data Configuration

Register No.		Details
Channel 1	Channel 2	
1st byte	5th byte	JOG speed (lower byte)
2nd byte	6th byte	JOG speed (upper byte)
3rd byte	7th byte	JOG acceleration/deceleration time (lower byte)
4th byte	8th byte	JOG acceleration/deceleration time (upper byte)

(3) Operation

Use the following procedure to perform JOG operations.

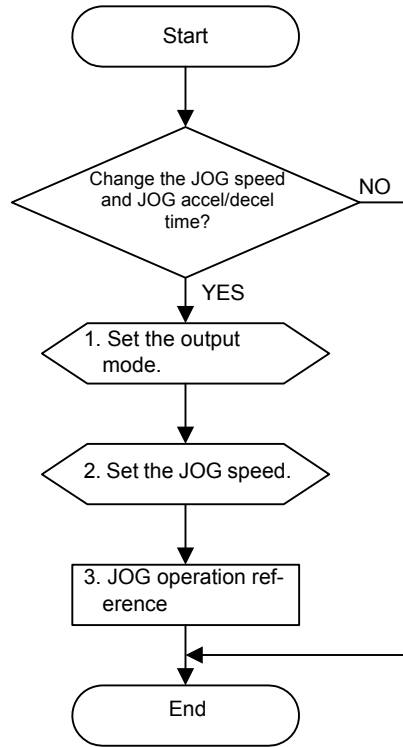

Once the output mode (step 1) and JOG speed (step 2) have been set, it is not necessary to set them again until there are changes.

1. Selecting the Output Mode

- Set the parameter number to 1 in the Parameter Number Selector output coils (PRMn0 to PRMn3).
- Set the output mode in the lower byte of output register OWxxxx+4 (for channel 1) or OWxxxx+6 (for channel 2).

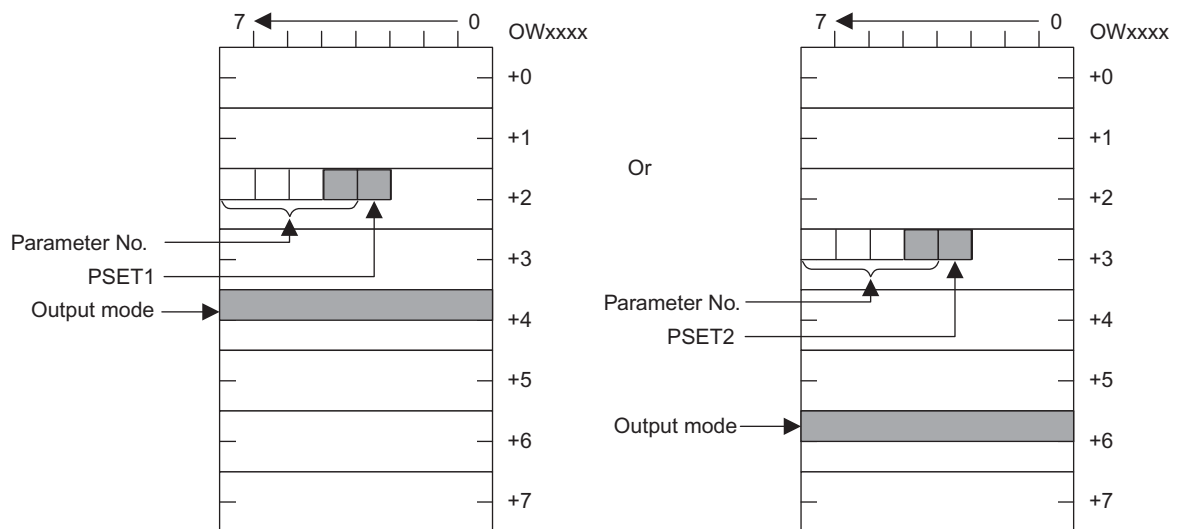

- Turn the Parameter Set/Monitor Selector output coil (PSETn) from OFF to ON.

2. Setting the JOG Speed and JOG Acceleration/Deceleration Time

- Set the parameter number to 2 in the Parameter Number Selector output coils (PRMn0 to PRMn3).
- Set the JOG speed in the lower byte of output register OWxxxx+4 (for channel 1) or OWxxxx+6 (for channel 2).
Set the JOG acceleration/deceleration time in the lower byte of output register OWxxxx+5 (for channel 1) or OWxxxx+7 (for channel 2).

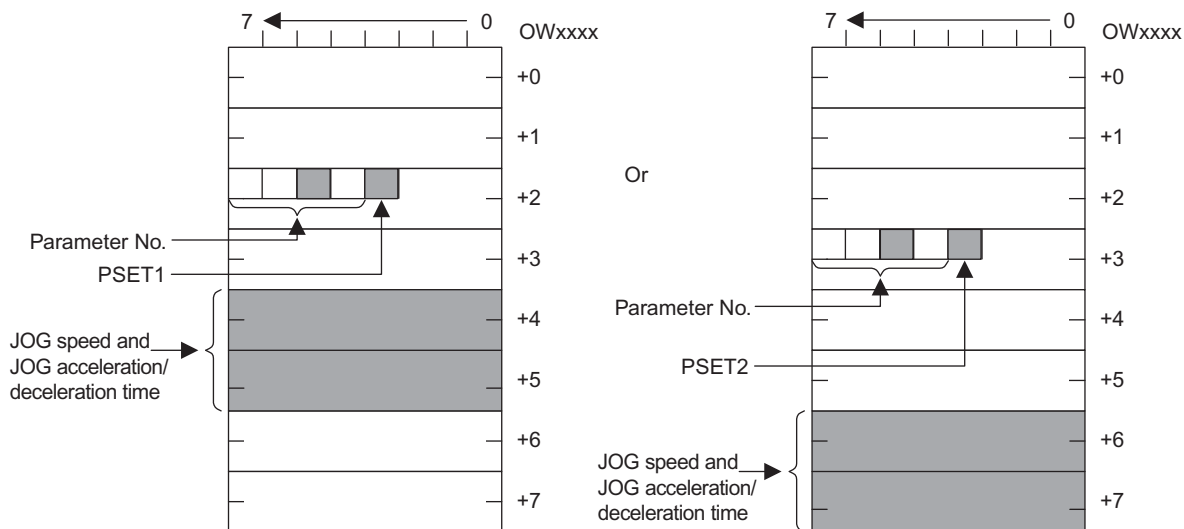

- Turn the Parameter Set/Monitor Selector output coil (PSETn) from OFF to ON.

3. JOG Operation Reference

- Turn the JOG Operation output coil (JOGn) from OFF to ON.

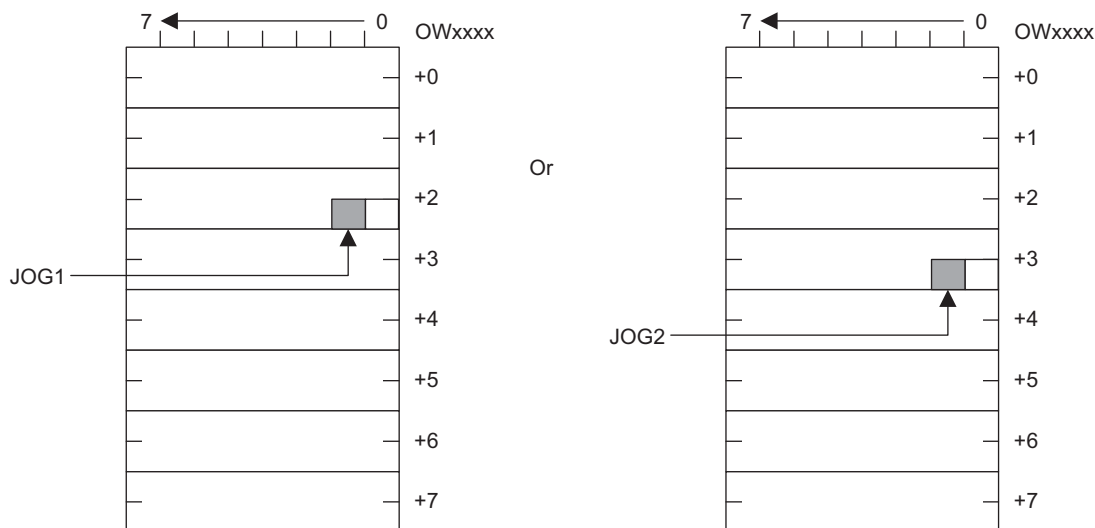

- Turn OFF the following output coils:

- Cancel (CANn)
- Positioning (MOVn)
- Zero Point Return (ZRNn)

- Cancel

To cancel jogging, turn the Cancel output coil (CANn) from OFF to ON during the JOG operation.

- Positioning completed.

6.7.4 Zero Point Return

(1) Overview

Outputs pulses at the set speed and direction when the ZRNn signal turns ON.

The acceleration/deceleration time, approach speed, and creep speed are set in the parameters.

The direction is specified by the REVn signal.

(a) Limit Switch Configuration

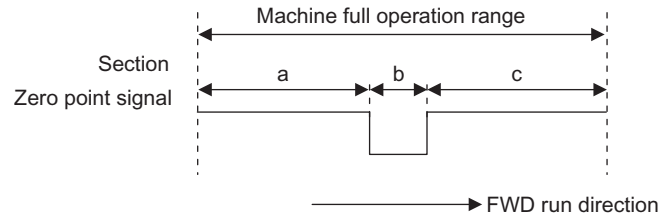

(b) Zero Point Return

- When zero point return starts in section a:
(When zero point signal becomes Hi at stop after zero point signal is detected)

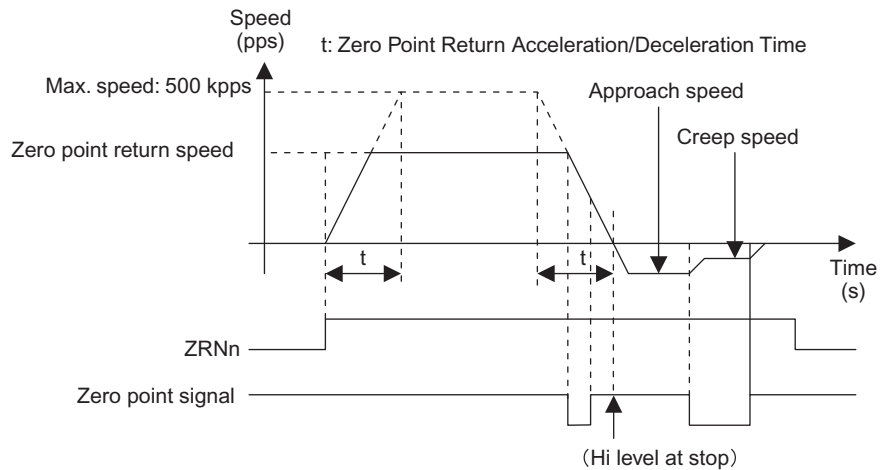

- When zero point return starts in section a:
(When zero point signal becomes Lo at stop after zero point signal is detected)

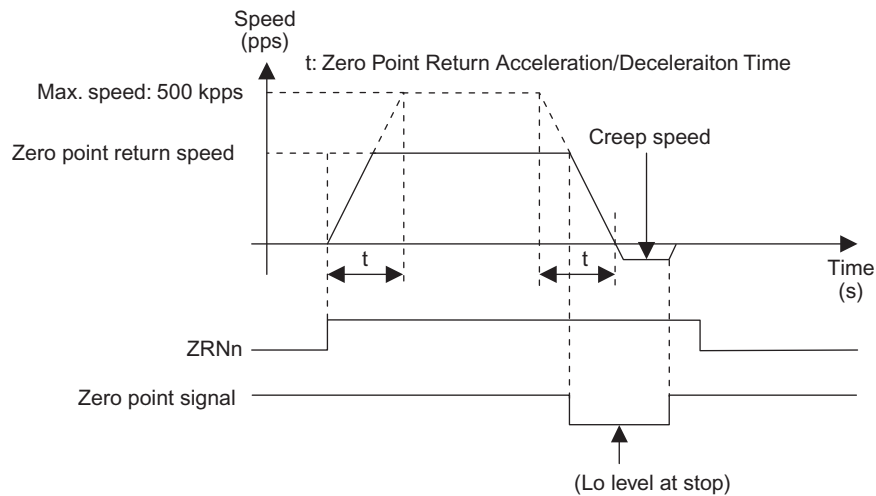

- When zero point return starts in section b:

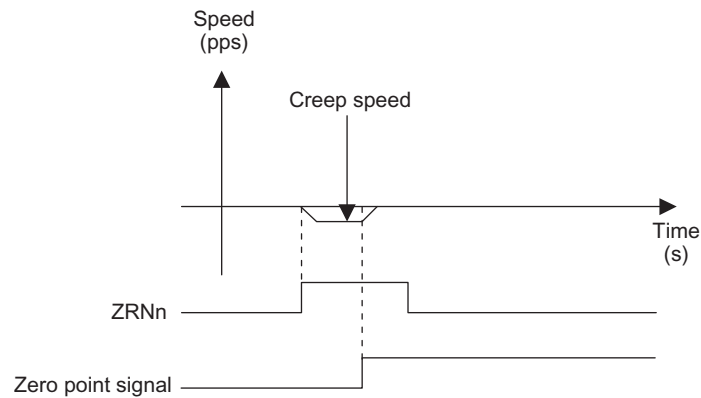

- When zero point return starts in section c:
Zero point return is not possible. Return to section a or b.
(The motor runs forward at zero point return speed and stops by forward run overtravel signal.)

(2) Related References

Use the following I/O data to execute instructions.

Symbol	Signal Name	Details
ZRNn *	Zero point return	This reference starts the zero point return operation.

* The letter "n" denotes the channel number 1 or 2.

(a) Parameters

Parameter No.	Parameter No. Setting				Name	Setting Range	Units	Default Setting
	PRMn 3	PRMn 2	PRMn 1	PRMn 0				
03	OFF	OFF	ON	ON	Zero point return speed	1 to 50000	10 pps	500
					Zero point return accel/decel time	50 to 5000	100 ms	100
04	OFF	ON	OFF	OFF	Zero point return approach speed	1 to 50000	10 pps	100
					Zero point return creep speed	1 to 50000	10 pps	50

(b) Digital Inputs

Symbol	Signal Name	Details
ZRNnL *	Zero return	Indicates that a zero point return operation is being performed.

* The letter "n" denotes channel number 1 or 2.

(c) Command Data Configuration

- Zero point return speed and zero point return acceleration/deceleration time

Register No.		Details
Channel 1	Channel 2	
1st byte	5th byte	Zero point return speed (lower byte)
2nd byte	6th byte	Zero point return speed (upper byte)
3rd byte	7th byte	Zero point return acceleration/deceleration time (lower byte)
4th byte	8th byte	Zero point return acceleration/deceleration time (upper byte)

- Zero point return approach speed and zero point return creep speed

Register No.		Details
Channel 1	Channel 2	
1st byte	5th byte	Zero point return approach speed (lower byte)
2nd byte	6th byte	Zero point return approach speed (upper byte)
3rd byte	7th byte	Zero point return creep speed (lower byte)
4th byte	8th byte	Zero point return creep speed (upper byte)

(3) Operation

Use the following procedure to perform the zero point return operation.

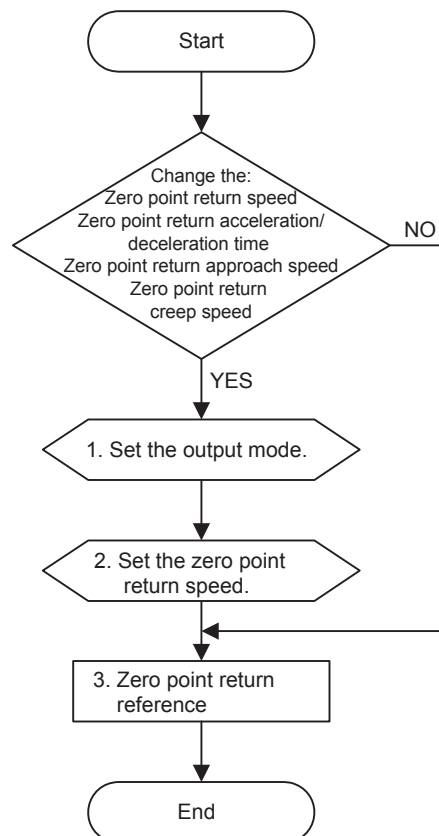

Once the output mode (step 1) and zero point return speed (step 2) have been set, it is not necessary to set them again until there are changes.

1. Selecting the Output Mode

- Set the parameter number to 1 in the Parameter Number Selector output coils (PRMn0 to PRMn3).
- Set the output mode in the lower byte of output register OWxxxx+4 (for channel 1) or OWxxxx+6 (for channel 2).

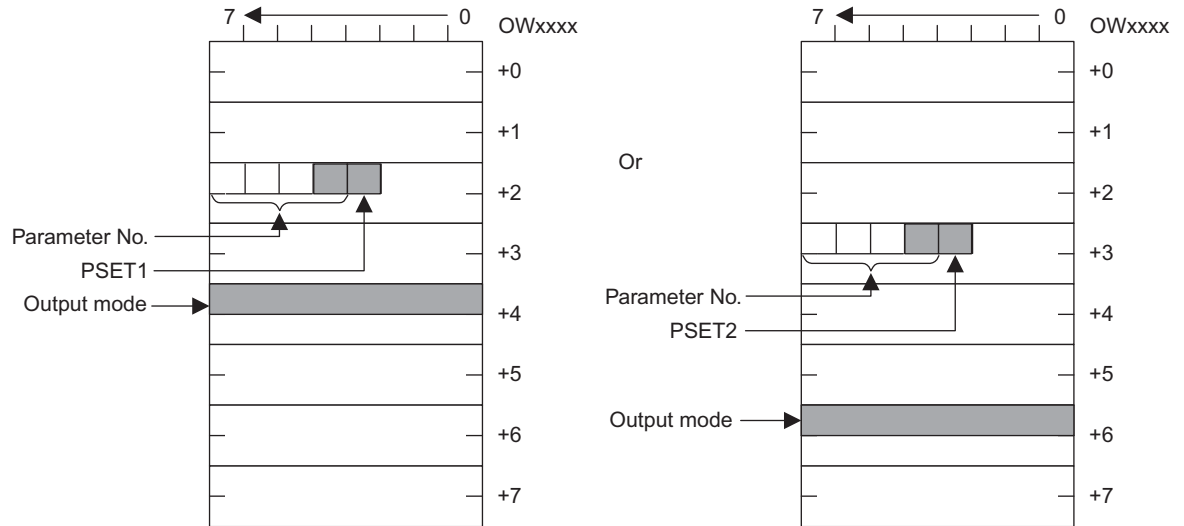

- Turn the Parameter Set/Monitor Selector output coil (PSETn) from OFF to ON.

2. Setting the Zero Point Return Speed and Zero Point Return Acceleration/Deceleration Time

- Set the parameter number to 3 in the Parameter Number Selector output coils (PRMn0 to PRMn3).
- Set the zero point return speed in output register OWxxxx+4 (for channel 1) or OWxxxx+6 (for channel 2).
Set the zero point return acceleration/deceleration time in output register OWxxxx+5 (for channel 1) or OWxxxx+7 (for channel 2).

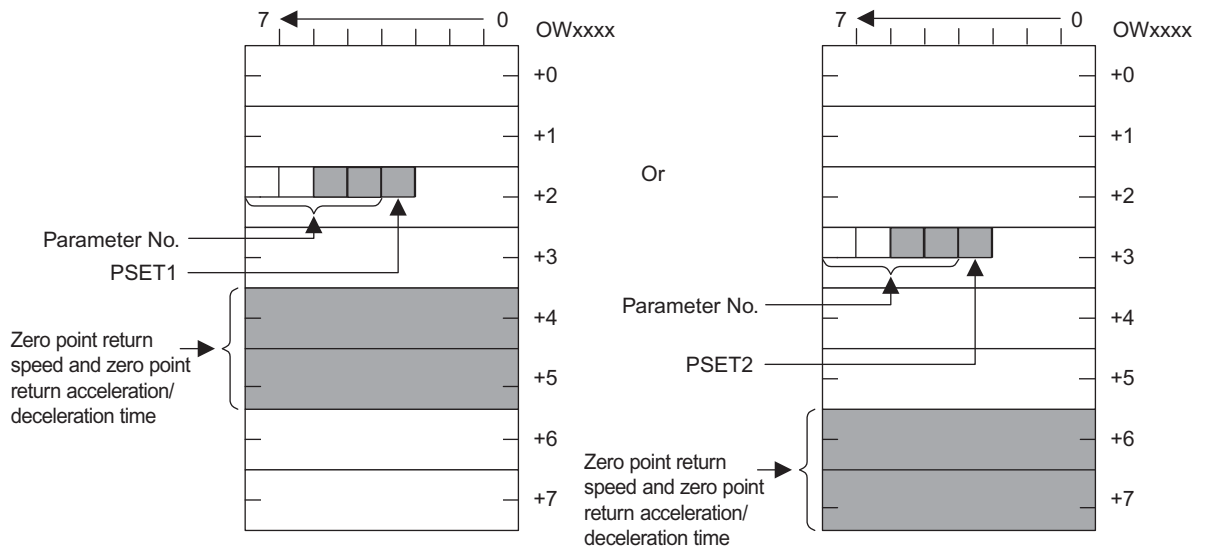

- Turn the Parameter Set/Monitor Selector output coil (PSETn) from OFF to ON.

3. Setting the Zero Point Return Approach Speed and Zero Point Return Creep Speed

- Set the parameter number to 4 in the Parameter Number Selector output coils (PRMn0 to PRMn3).
- Set the zero point return approach speed in output register OWxxxx+4 (for channel 1) or OWxxxx+6 (for channel 2).
Set the zero point return creep speed in output register OWxxxx+5 (for channel 1) or OWxxxx+7 (for channel 2).

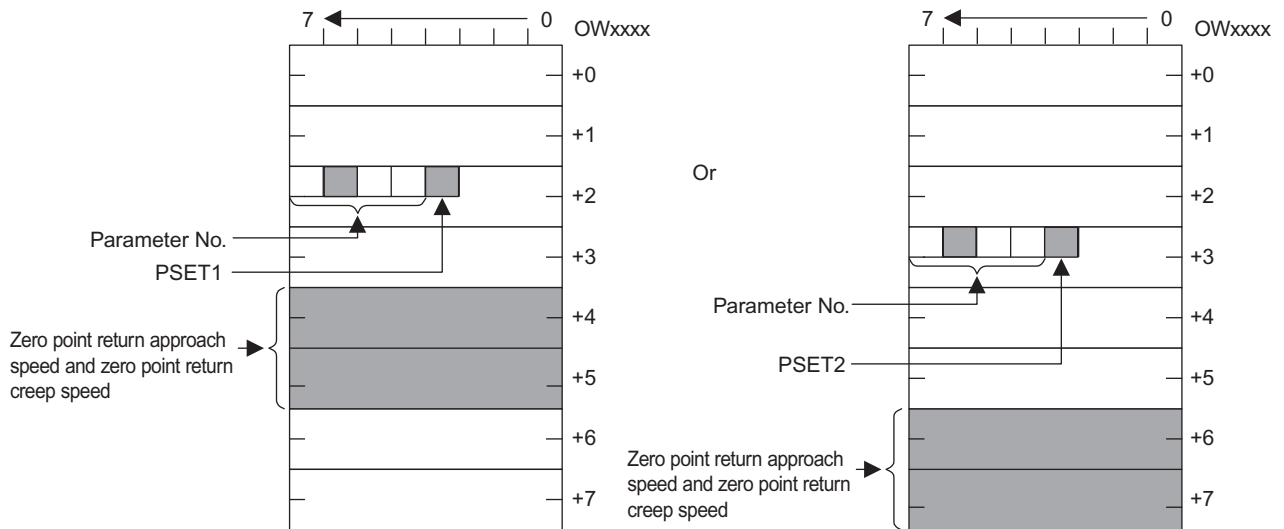

- Turn the Parameter Set/Monitor Selector output coil (PSETn) from OFF to ON.

4. Zero Point Return Reference

- Turn the Zero Point Return output coil (ZRNn) from OFF to ON.

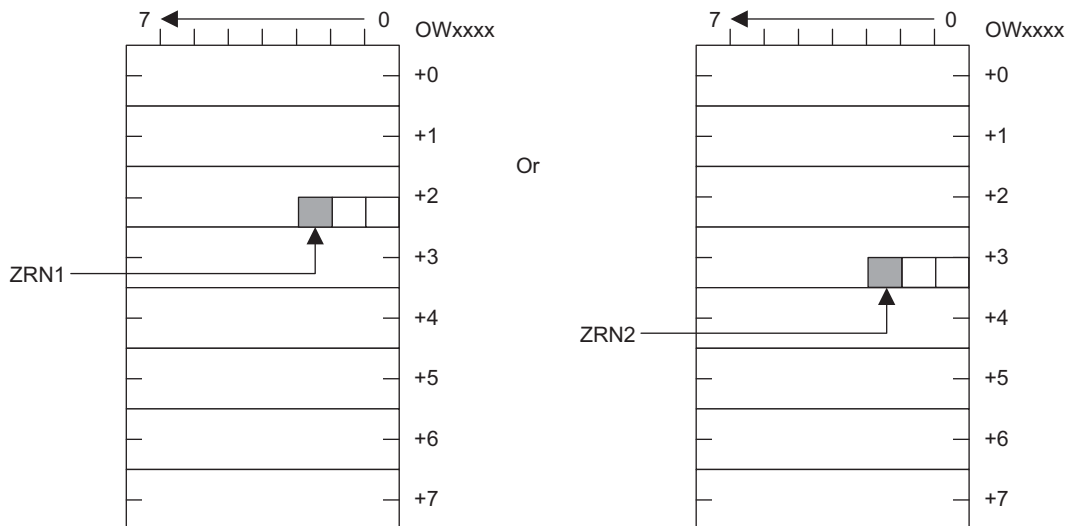

- Turn OFF the following output coils:

- Cancel (CANn)
- Positioning (MOVn)
- JOG Operation (JOGn)

- Cancel

To cancel the zero point return, turn the Cancel output coil (CANn) from OFF to ON during the operation.

- Positioning completed.

PLC Module

This chapter provides an outline of the PLC Module, which can be connected using a MECHATROLINK Interface.

7.1 MP940	7-2
7.1.1 External Appearance and Configuration	7-2
7.1.2 Specifications and Functions	7-5

7.1 MP940

7.1.1 External Appearance and Configuration

The following diagram shows the MC400-Series MP940 Module's external parts.

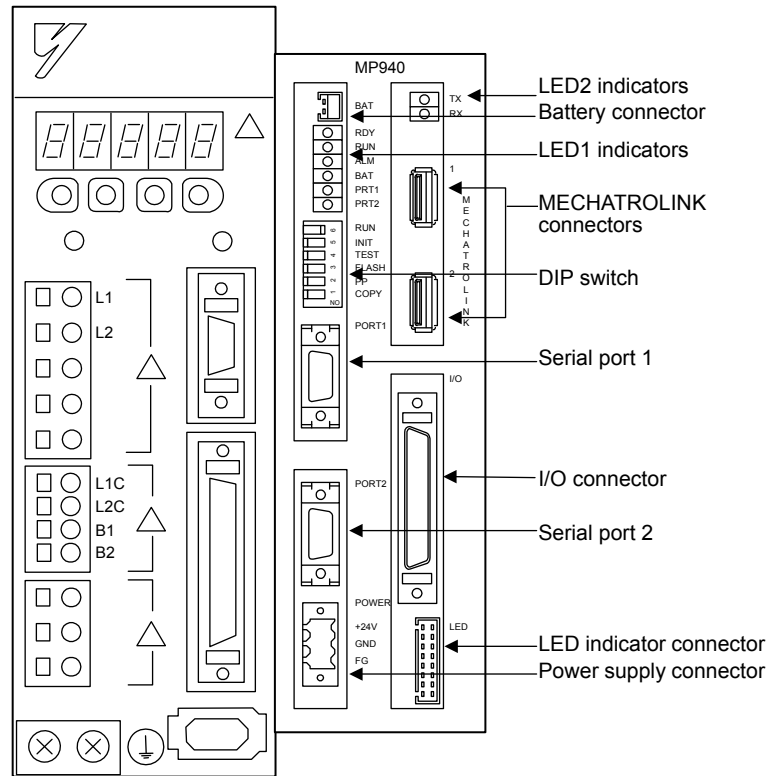

(1) LED1

LED1 indicators show the Module's status.

Indicator Name	Indicator Color	Meaning When Lit or Flashing
RDY	Green	System operating normally.
RUN	Green	Program running.
ALM	Red	Lit: Minor system failure occurred. Flashing: System fault or failure occurred.
BAT	Red	Battery needs replacing.
PRT1	Green	Serial port 1 sending data.
PRT2	Green	Serial port 2 sending data.

(2) LED2

LED2 indicators show the MECHATROLINK's status.

Indicator Name	Indicator Color	Meaning When Lit
TX	Green	Sending data
RX	Green	Receiving data

(3) Battery Connector

Connects a backup battery for the program memory.

- Connector model: DF3-2P-2DS (HIROSE)
- Battery: ER6VLY + DF3.CONNECTOR



Terminal Name	Function
BAT IN	Battery input
GND	Terminal ground

(4) DIP Switch

The DIP switch consists of six pins. The pins are numbered from 1 to 6, as shown in the diagram.

Each pin turns ON when it is moved to the right.

The pin settings are enabled the next time the power supply is turned ON.

Each pin's function is shown in the following table.

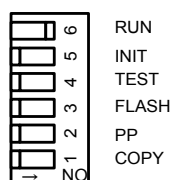

Pin No.	Name	Setting	Function	Default
6	RUN	ON	Runs the program.	ON
		OFF	Stops the program.	
5	INIT	ON	Pin 3 OFF: Copies a data from Flash Memory to RAM. ON: Clears Flash Memory.	OFF
		OFF	Pin 3 OFF: Does not copy a data from Flash Memory to RAM. ON: Setting prohibited.	
4	TEST	ON	Terminal mode/initialization mode	OFF
		OFF	Online	
3	FLASH	ON	Copies a data from Flash Memory to RAM.	OFF
		OFF	Does not copy a data from Flash Memory to RAM.	
2	PP	ON	Serial port 1*	OFF
		OFF	Serial port 1 is an MPE720 connection port when this pin is OFF.	
1	COPY (Valid when Pin 3 is ON)	ON	M-register copy from flash memory provided.	OFF
		OFF	M-register copy from flash memory not provided.	

* Turn ON this pin when communicating with a MEMOBUS device using the communication parameters defined in the Module configuration. If this pin is ON but the communication parameters have not been defined, the default setting (i.e., MPE720 connection port settings) will be used.

(5) Serial Port 1

Use this port for MPE720 connection.

Also, the MP940 can communicate with communication devices on the MEMOBUS Network by means of RS-232C via serial port 1.

(6) Serial Port 2

Use this port for RS-422/485 connections.

(7) Power Supply Connector

Use this connector to supply a 24-VDC power supply to the MP940 Module.

(8) MECHATROLINK Connector

Use this connector to connect distributed I/O via MECHATROLINK.

(9) I/O Connectors

Use the I/O Connectors to connect the MP940 Module to external input signals, analog outputs, and pulse inputs.

(10) LED Connectors

By connecting to the LED indicator block shown below, you can display the DI/DO status connected to the I/O Connectors.

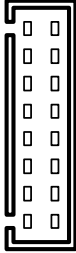

LED

No.	Signal Name	Remarks	No.	Signal Name	Remarks
1	VCC	5-V power supply	2	—	—
3	—	—	4	LED0	—
5	LED1	—	6	—	—
7	LED2	—	8	LEDPW0	—
9	LEDPW3	—	10	LEDPW2	—
11	LED3	—	12	LED4	—
13	LED5	—	14	LEDPW1	—
15	LED7	—	16	LED6	—

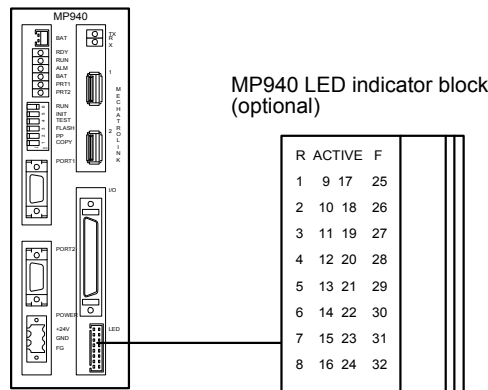

Fig 7.1 LED Indicator Block Diagram

7.1.2 Specifications and Functions

(1) General Specifications

The general specifications of the MP940 Module are shown below.

Table 7.1 General Specifications of MP940 Modules

Item		Specifications
Environmental Conditions	Ambient Operating Temperature	0 to 55°C
	Storage Temperature	-20 to 85°C
	Operating Humidity	30% to 95% (with no condensation)
	Storage Humidity	5% to 95% (with no condensation)
	Pollution Level	Pollution level 1 according to JIS B 3501
	Corrosive Gas	No combustible or corrosive gas
	Operating Altitude	Less than 2,000 m above sea level
Electrical Operating Conditions	Noise Resistance	1,500 Vp-p in either normal or common mode with pulse widths of 100 ns and 1 μs and rise time of 1 ns (with impulse noise simulator) (conforming to JIS B 3502)
Mechanical Operating Conditions	Vibration Resistance	10 to 57 Hz with half-amplitude of 0.075 mm 57 to 150 Hz at fixed acceleration of 9.8 m/s ² 10 sweeps in the X, Y, and Z directions (sweep period: 1 octave/min) (conforming to JIS B 3502)
	Shock Resistance	Conforming to JIS B 3502: Peak acceleration of 147 m/s ² twice for 11 ms in the X, Y, and Z directions
Installation Requirements	Ground	Ground to 100 Ω max.
	Cooling Method	Natural cooling

(2) Hardware Specifications

The hardware specifications of the MP940 Module are shown in the following table.

Table 7.2 Hardware Specifications of the MP940 Module

Item		Specifications
Name		MP940 Module
Model Number		JEPMC-MC400
Communication Ports	RS-232C 1 port	Baud rate: 9.6 K or 19.2 Kbps MDR-14 (special pin assignments) Protocols: MEMOBUS, No-protocol, or MELSEC communication
	RS-422/485 1 port	Baud rate: 9.6 K or 19.2 Kbps MDR-14 (special pin assignments) Protocols: MEMOBUS, No-protocol, or MELSEC communication
Indicators (LED)	Module Status LED Indicators	READY (Green) RUN (Green) ALM (Red) BATL (Red) PRT1 (Green) PRT2 (Green)
	MECHATROLINK Operation Status LED Indicators	RX (Green) TX (Green)
Setting Switches		Mode setting DIP switch RUN INIT TEST FLASH PP COPY
Input Signal	Number of Inputs	8 points/common
	Input Format	Sinking or sourcing
	Input Type	Type 1 (JIS-B3501)
	Isolation Method	Photocoupler
	Working Voltage	17.4 to 28.8 VDC, 35 VDC (peak)
	Rated Current	5.3 mA
	Input Impedance	Approx. 4.4 kΩ
	Operating Voltages	ON voltage: 15 VDC min. OFF voltage: 5 VDC max.
	OFF Current	0.9 mA max.
	Response Time	OFF to ON: 0.5 ms or less ON to OFF: 1.5 ms or less
Output Signals	Number of Outputs	8 points/common
	Output Format	Sinking
	Output Type	Transistor output
	Isolation Method	Photocoupler
	Load Voltage	19.2 to 28.8 VDC, 35 VDC (peak)
	Load Current	0.1 A/circuit, 0.8 A/common
	ON Voltage	1.0 V max.
	External Power Supply	24 VDC ±20%, 15 mA
	Output Protection	1 fuse per common
	Fuse Rating	1.5 A (opening time: 5 seconds max. at 3A)
	Response Time	OFF to ON: 0.25 ms or less ON to OFF: 1 ms or less

Table 7.2 Hardware Specifications of the MP940 Module (cont'd)

Item		Specifications
Pulse Inputs	Input Circuit	5 V differential, maximum 1 MHz input
	Input Method	Phase-A and phase-B inputs ($\times 1$, $\times 2$, or $\times 4$ multiplication), A/B mode, sign mode, up-down mode
	Counter Latch	External signal can be switched between 5 V, 12 V, and 24 V.
Analog Inputs		SGDH-□□□E SERVOPACK
Analog Outputs	Resolution	16 bits
	Output Range	0 to ± 10 V
Power Supply Input	Input Signal	24 VDC $\pm 20\%$ (19.2 to 28.8 VDC)
	Input Current	0.4 A
	Fuse Rating	1.5 A
	Safety Standards	Conforming to UL and CSA standards
Dimensions (mm)		44 \times 142 \times 128 (W \times H \times D)

(3) Motion Control Function Specifications

The motion control function specifications of the MP940 are shown in the following table.

Table 7.3 MP940 Motion Control Function Specifications

Item		Specifications
Number of Controlled Axes		1 axis
Control Specifications	PTP Control	Linear, rotary, and infinite-length axes
	Interpolation	Linear
	Speed Reference Output	Available
	Torque Reference Output	Available
	Position Control	Positioning, external positioning, zero point return, interpolation, interpolation with position detection function, fixed speed feed, fixed length feed
	Phase Control	Available
Position Control	Reference Unit	mm, inch, deg, pulse
	Reference Unit Minimum Setting	1, 0.1, 0.01, 0.001, 0.0001, 0.00001
	Maximum Programmable Value	-2147483648 to +2147483647 (signed 32-bit value)
	Speed Reference Unit	mm/min, inch/min, deg/min, pulse/min
	Acceleration/Deceleration Type	Linear, asymmetric, S-curve
	Override Function	0.01% to 327.67%
Coordinate System		Rectangular coordinates
Zero Point Return		Eight types DEC1 + phase C DEC1+ZERO DEC2 + phase C DEC2+ZERO DEC1+LMT DEC1+LMT+ZERO Phase C ZERO
Programming	Language	Special motion language ladder program
	Number of Tasks	Up to eight programs can be executed in parallel.
	Number of Programs	Up to 32
	Program Capacity	80 Kbytes
Applicable SERVOPACK		Analog: SGDH-□□□E SERVOPACK
Encoder		Incremental or absolute
Speed Control	Speed Reference	-327.68% to 327.67%/Rated speed Torque control function available
	Acceleration and Deceleration Type	Linear, asymmetrical, S-curve (travel average)
Torque Control	Torque Reference	-327.68% to 327.67%/Rated torque Speed control function available
Phase Control	Speed Reference Units	-327.68% to 327.67%/Rated speed
	Speed Compensation	-327.68% to 327.67%/Rated speed
	Position Compensation	-2147483648 to 2147483647 pulse

Table 7.3 MP940 Motion Control Function Specifications (cont'd)

Item	Specifications
Commands	<p>Axis Move Commands: 5 commands MOV, MVS, ZRN, SKP, EXM</p> <p>Basic Control Commands: 5 commands ABS, INC, POS, MVM, PLD</p> <p>Speed and Acceleration/Deceleration Commands: 8 commands ACC, DCC, SCC, VEL, IAC, IDC, IFP, FMX</p> <p>High-level Control Commands: 4 commands PFN, INP, SNG, UFC</p> <p>Control Commands: 10 commands MSEE, TIM, IOW, END, RET, EOX, IF ELSE IEND, WHILE WEND, PFORK JOINTO PJOINT, SFORK JOINTO SJOINT</p> <p>Math and Sequence Control Commands: 32 commands =, +, -, *, /, MOD, , ^, &, !, (), S {}, R {}, SIN, COS, TAN, ASN, ACS, ATN, SQRT, BIN, BCD, ==, <>, >, <, >=, <=, SFR, SFL, BLK, CLR</p>

MECHATROLINK-II Repeater

This chapter provides an overview of the repeater JEPMC-REP2000 for the MECHATROLINK-II.

8.1 Overview	8-2
8.2 External View and Components	8-3
8.3 System Configuration	8-5
8.3.1 System Configuration Example	8-5
8.4 Specifications	8-6
8.5 Application	8-8
8.5.1 Restrictions	8-8
8.5.2 Operation	8-10

8.1 Overview

The JEPMC-REP2000 (hereinafter referred to as REP2000 or Repeater) is a repeater for MECHATROLINK-II transmission system and serves as a module to extend the distance of MECHATROLINK-II network and increase the number of connectable slave stations.

The REP2000 has two MECHATROLINK-II connection ports: One port to connect to the terminal of Master-side network, and the other to connect to the terminal of the extended network. These two ports are functionally identical. A terminator is built in each port.

The internal circuit of REP2000 eliminates receive signal waveform deformation caused by radiation and noise on the transmission route.

The REP2000 has three LED indicators to indicate the status: Power-ON, CN1 busy, and CN2 busy.

A +24 VDC power supply is required for operation.





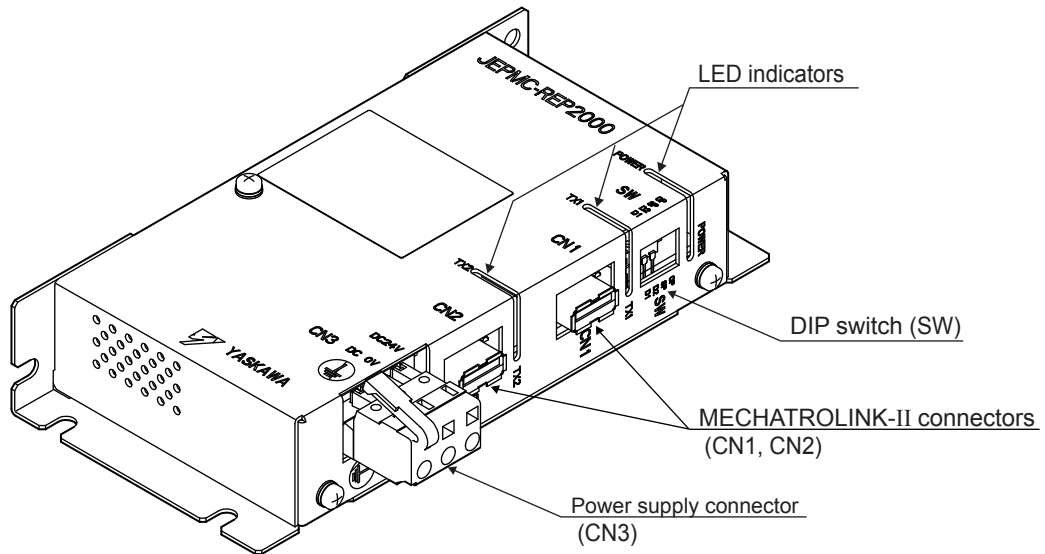

8.2 External View and Components

The external view and components of REP2000 are shown below.





(1) LED Indicators

The following LED indicators indicate the REP2000 status.

LED Location		Name	Indicator Color	Meaning When Lit
Front Surface (The surface with the nameplate)	Right Side			
POWER 	 POWER	POWER	Green	Power ON
TX1 	 TX1	TX1	Green	CN1 busy (in transmitting data)
TX2 	 TX2	TX2	Green	CN2 busy (in transmitting data)

(2) MECHATROLINK-II Connectors CN1 and CN2

The Master-side MECHATROLINK-II network and the extended line of MECHATROLINK-II network are connected via MECHATROLINK-II connection port connectors CN1 and CN2 on the REP2000.

	Pin No.	Signal Name	Description
 CN1  CN2	1	(NC)	Disconnected
	2	/S	MECHATROLINK-II
	3	S	MECHATROLINK-II
	4	FG	Frame ground

(3) Power Supply Connector

Connect an external +24 VDC power supply to the power supply connector.

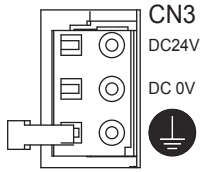

Pin No.	Signal Name	Description
1	FG	Frame ground
2	024V	0 VDC input
3	+24V	24 VDC input

(4) DIP Switch

The DIP switch is for future use. Leave all the pins to OFF.

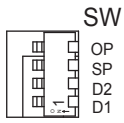

OP	Function	SP	Function	D2	D1	Function
OFF	None (Factory setting)	OFF	None (Factory setting)	OFF	OFF	None (Factory setting)
ON	None	ON	None	OFF	ON	None
				ON	OFF	None
				ON	ON	None

8.3 System Configuration

8.3.1 System Configuration Example

The figure below shows the configuration example of MECHATROLINK-II network system with a REP2000.

(1) For 30m Max. Extension of Network Distance

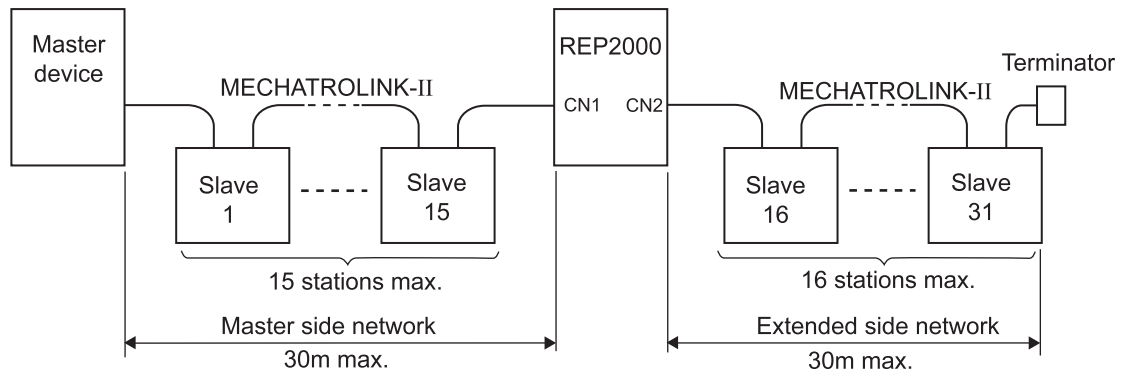

(2) For 50m Max. Extension of Network Distance

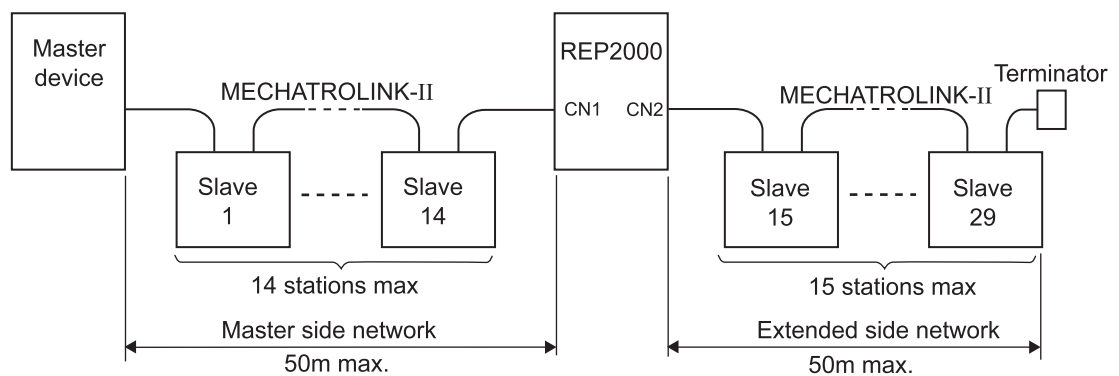

8.4 Specifications

(1) General Specifications

The table below shows the general specifications of REP2000.

Table 8.1 General Specifications of JEPMC-REP2000

Item		Specifications
Environmental Conditions	Ambient Operating Temperature	0 to +55 °C
	Storage Temperature	-25 to +85 °C
	Ambient Operating Humidity	30 to 95% RH (without condensation)
	Storage Humidity	5 to 95% RH (without condensation)
	Pollution Level	Conforming to JIS B3501 (Pollution level 1)
	Corrosive Gas	Not subjected to inflammable or corrosive gas
	Operating Altitude	2,000m max. above sea level
Mechanical Operating Conditions	Vibration Resistance	Conforming to JIS B3502 Vibration amplitude at acceleration: 10 ≤ f < 57 Hz with half-amplitude of 0.075 mm 57 ≤ f ≤ 150 Hz at constant acceleration of 9.8 m/s ² 10 sweeps in the X, Y, and Z directions (sweep time: 1 octave/min.)
	Shock Resistance	Conforming to JIS B3502 Peak acceleration of 147 m/s ² twice for 11 ms in the X, Y, and Z directions
Electrical Operating Conditions	Noise Resistance	Conforming to EN 61000-6-2 and EN 55011 (Group1 ClassA) Power supply noise (FT noise): 2 kV or more for 1 min. Radiation noise (FT noise): 1 kV or more for 1 min. Ground noise (Impulse noise): 1 kV or more for 10 min. Static electricity noise (Contact radiation): 4 kV or more 10 times
Installation Requirements	Grounding	Ground to 100 Ω or less
	Cooling Method	Natural cooling

(2) Hardware Specifications

The table below shows the hardware specifications of REP2000.

Table 8.2 Hardware Specifications of JEPMC-REP2000

Item		Specifications
Name		REP2000 Repeater
Model Number		JEPMC-REP2000
Communication board	Applicable Communication Protocol	MECHATROLINK-II (10 Mbps)
	Number of MECHATROLINK Ports	2 (CN1 and CN2) Refer to (1) <i>Connection to MECHATROLINK of 8.5.2 Operation</i> for details.
	Master-side Port	Connect to the Master-side network Number of connectable slave stations for Master-side network: 15 stations for the network distance of 30m max. 14 stations for the network distance of 50m max. Refer to (1) <i>Maximum Number of Slave Stations of 8.5.1 Restrictions</i> for details.
	Extended-network-side Port	Connect to the extended network Number of connectable slave stations for extended network: 16 stations for the network distance of 30m max. 15 stations for the network distance of 50m max. Refer to (1) <i>Maximum Number of Slave Stations of 8.5.1 Restrictions</i> for details.
	Arbiter	First request for higher priority. CN1 has a priority at simultaneous requests.
	Terminator	One (130 Ω) for each port
Indicator Lamps (LED)	Status Indication	3 LED indicator lamps POWER (green): Power ON TX1 (green): CN1 busy (in transmitting data) TX2 (green): CN2 busy (in transmitting data)
Others	Mounting Orientation	Vertical or horizontal (The nameplate upward)
	External Power Supply	+24 VDC (+19.2 to +28.8V), 100 mA
	Dimensions in mm	30 × 160 × 77 (W × H × D)
	Mass	0.4 kg

8.5 Application

8.5.1 Restrictions

(1) Maximum Number of Slave Stations

The number of connectable slave stations in the Master-side network or the extended network is limited by the MECHATROLINK-II cable length as shown in the table below.

Table 8.3 Number of Connectable Slave Stations

Classification	Cable Length	Number of Slave Stations
Master-side Network *1	30m max.	15 stations max.
	50m max.	14 stations max.
Extended-side Network *2	30m max.	16 stations max.
	50m max.	15 stations max.

* 1. The number of connectable slave stations (16 stations for 30m cable length, 15 stations for 50m cable length) includes a REP2000 as a REP2000 applies load for one station.

* 2. Install a terminator on the slave station that is the terminal of the extended network.

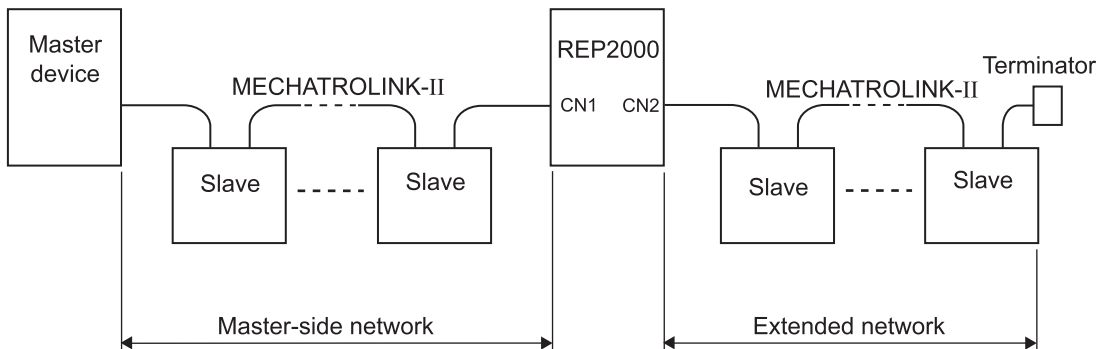

- Note: 1. Total number of slave stations in a whole network depends on the specifications of Master station.
 2. The REP2000 is not included in the total number of slave stations specified in the specifications of Master station.
 3. The minimum distance between stations is 0.5m no matter whether a REP2000 is connected or not.

(2) Prohibited Use of Multiple Repeaters

More than one REP2000 cannot be connected in a network.

The figure below shows the network examples that must not be designed.

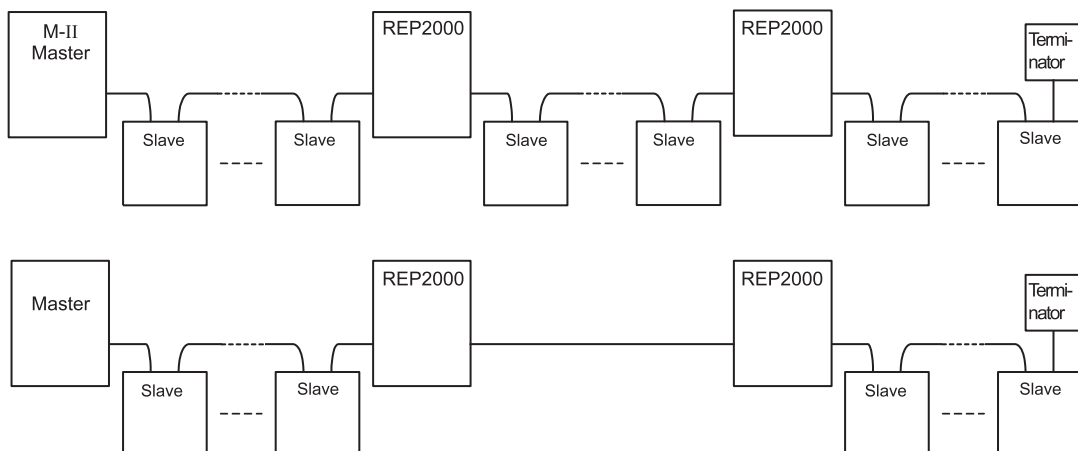

(3) Mounting Orientation

(a) Recommended Mounting Orientation

The REP2000 can be mounted either vertically or horizontally (with the nameplate upward).

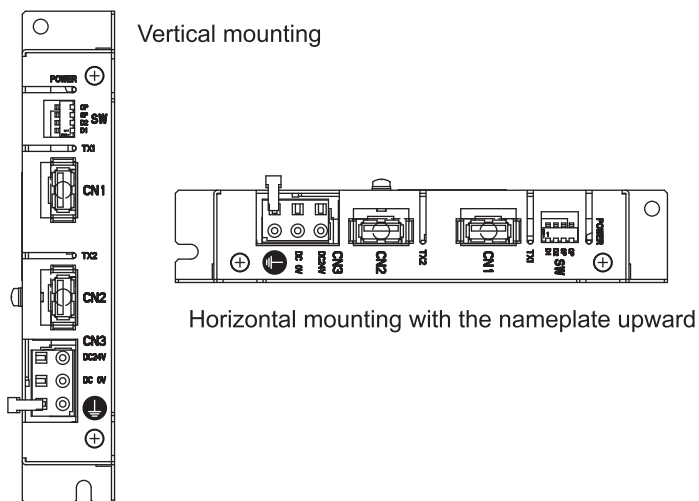

(b) Prohibited Mounting Orientation

Do not mount the REP2000 up-side-down or horizontally with the nameplate downward.

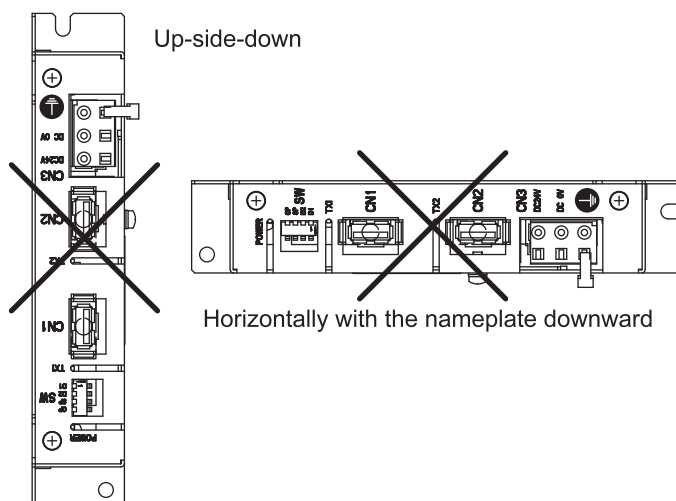

8.5.2 Operation

(1) Connection to MECHATROLINK

Connect either CN1 or CN2 to the Master-side network, and the other to the extended network.

(2) Arbiter

Two ports CN1 and CN2 are normally in the status ready to receive data. The port that starts receiving data first becomes the data receiving port, and the other becomes the data transmitting port.

Two ports return to the status ready to receive data after having completed receiving or transmitting data. With the MECHATROLINK-II protocol, the Master station and a slave station transmit data alternately, there will be no conflict of receiving data between two ports.

(3) LED Indicators For Transmission Status

The LED indicator TX1 or TX2 lights when the port CN1 or CN2 is transmitting data respectively: TX2 lights when CN1 is the data receiving port and CN2 is the data transmitting. TX1 lights when CN1 is the data transmitting port and CN2 is the data receiving port. However, data are frequently received and transmitted in a short cycle, you can see both indicators as if they were lit simultaneously.

The Master-side LED lights normally darker than the other. It is because the extended side LED lights when either the Master or a Master-side slave station is transmitting data while the Master-side LED lights when an extended side slave is transmitting data. Accordingly, the Master-side LED lights more brightly as the number of extended-side slave stations increases.

- Operation Example of LED Indicators

In this example, CN1 is connected to the Master-side network.

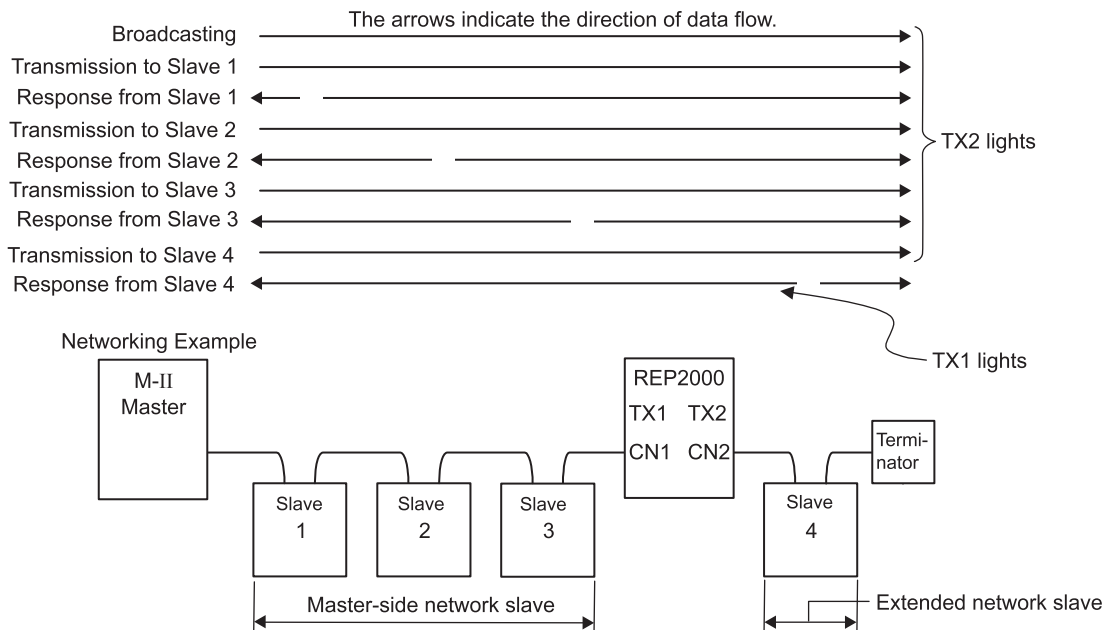

1. TX2 lights when the MECHATROLINK-II Master station is transmitting data.

2. TX2 lights also when receiving response from Slave 1, 2, or 3.

Because the signals sent from Slave 1, 2, and 3 are the CN1 receiving signals for the REP2000.

3. When Slave 4 returns a response, TX1 lights.

As a result, TX2 lights 8 times while TX1 lights once in 1 transmission cycle.

Connections

This chapter explains the connections between MECHATROLINK devices.













9.1 Connections between MECHATROLINK Devices	9-2
9.1.1 MECHATROLINK Connectors	9-2
9.1.2 MECHATROLINK Cables	9-5
9.1.3 Connection Example	9-10
9.2 External Wiring	9-17
9.2.1 Wiring in a Panel	9-17
9.2.2 Indoor Wiring Between Panels	9-18
9.2.3 Outdoor Wiring Between Panels	9-19
9.2.4 Grounding	9-20
9.2.5 Grounding Control Panels	9-21

9.1 Connections between MECHATROLINK Devices

9.1.1 MECHATROLINK Connectors

(1) Connector Types

The MECHATROLINK connectors for Master Modules differ as shown below.

Master Module		Number of Connectors	Appearance	Connector Name
MP910	ISA	2		PORT1
				PORT2
	C-PCI	4		PORT1
				PORT2
MP920 (SVB-01)		2		CN1
MP930		1		CN1
MP940		2		1
				2
MP2100		1		M-I/II
MP2300		1		M-I/II
MP2200/ MP2300 (SVB-01)		2		CN1
				CN2



- There are two of each type of connector built into the MP910, so you can create two independent MECHATROLINK networks.
- There are two designs of MECHATROLINK connector, those that connect top and bottom, and those that connect left and right. Their function, however, remains the same.

(2) Internal Connections

The MECHATROLINK connectors are connected as shown below.

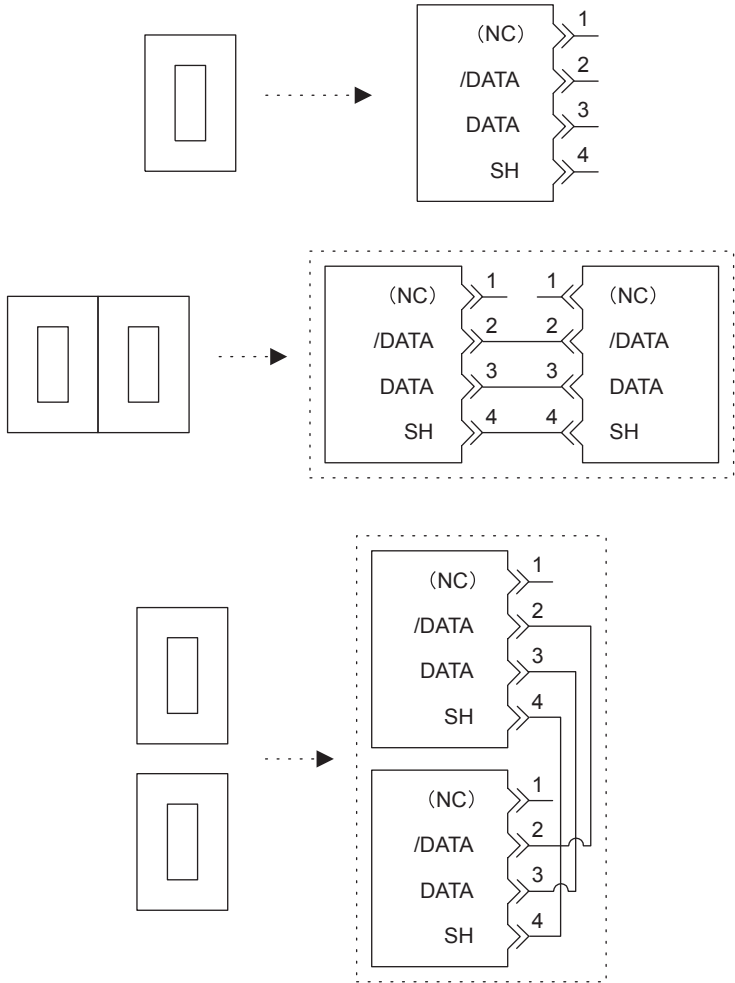

Insert an USB terminator (JEPMC-W6020 for M-I, JEPMC-W6022 for M-II) into both ends of the system.

(3) Connector Specifications

The specifications for the above connectors are shown below.

Name	Number of Pins	Connector Model		
		Module Connector	Cable Connector	Manufacturer
MECHATROLINK Connectors	4	1903814-1	2040305-1	Tyco Electronics Japan G.K.

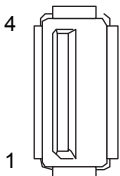

No.	Signal Name	Description
1	(NC)	Not used
2	/DATA	Signal minus (-) side
3	DATA	Signal plus (+) side
4	SH	Not used
Shell	Shield	Connect a shielded cable.

(4) Connection Method

(a) Master Station

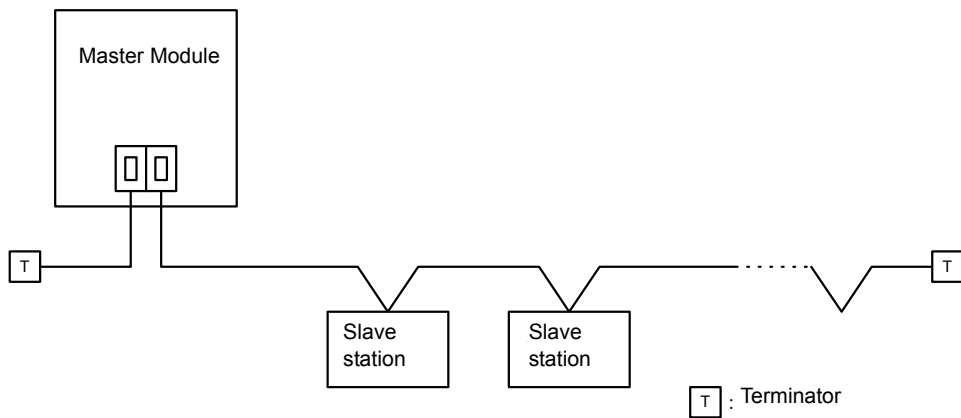

(b) Slave Station

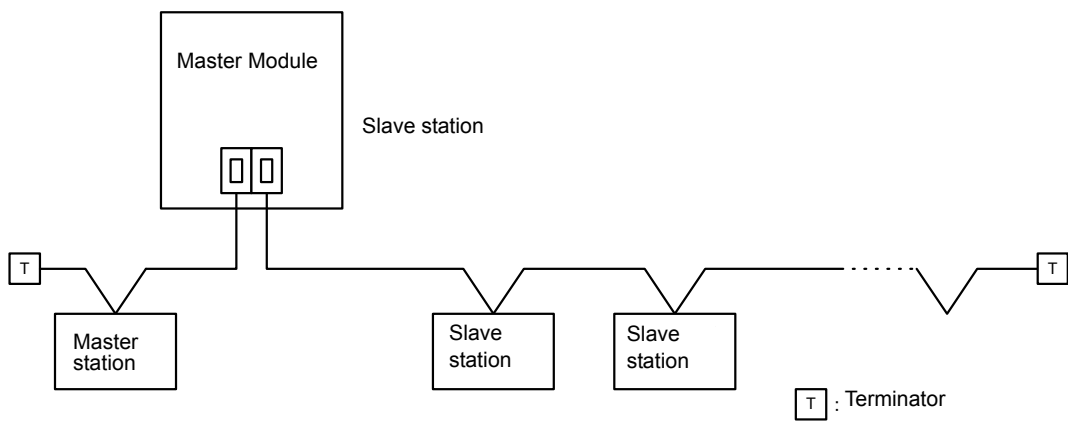

- If there is only one connector, a terminator is not required.
- If there are two connectors, you can connect either. Connectors that operate top to bottom and connectors that operate left to right both function the same.

9.1.2 MECHATROLINK Cables

(1) Standard Cable List

Yaskawa manufactures the following standard cables.

(a) For MP900 Series

Cable Name and Specifications	Model	Length (m)
MECHATROLINK Cable USB connector to USB connector	JEPMC-W6000-A3	0.3
	JEPMC-W6000-01	1
	JEPMC-W6000-03	3
	JEPMC-W6000-05	5
	JEPMC-W6000-10	10
	JEPMC-W6000-20	20
	JEPMC-W6000-30	30
MECHATROLINK Cable USB connector to USB connector (with ferrite core)	JEPMC-W6001-A3	0.3
	JEPMC-W6001-01	1
	JEPMC-W6001-03	3
	JEPMC-W6001-05	5
	JEPMC-W6001-10	10
	JEPMC-W6001-20	20
	JEPMC-W6001-30	30
	JEPMC-W6001-40	40
MECHATROLINK Cable USB connector to loose wire	JEPMC-W6010-07	7
	JEPMC-W6010-10	10
	JEPMC-W6010-15	15
	JEPMC-W6010-20	20
	JEPMC-W6010-30	30
	JEPMC-W6010-40	40
JEPMC-W6010-50	50	
Terminator (Terminating resistor) 120 Ω	JEPMC-W6020	—



If there is transmission problems such as noise interference, use a cable with ferrite core.

(b) For MP2000 Series

Cable Name and Specifications	Model	Length (m)
MECHATROLINK Cable USB connector to USB connector	JEPMC-W6002-A5	0.5
	JEPMC-W6002-01	1
	JEPMC-W6002-03	3
	JEPMC-W6002-05	5
	JEPMC-W6002-10	10
	JEPMC-W6002-20	20
	JEPMC-W6002-30	30
	JEPMC-W6002-40	40
	JEPMC-W6002-50	50
MECHATROLINK Cable USB connector to USB connector (with ferrite core)	JEPMC-W6003-A5	0.5
	JEPMC-W6003-01	1
	JEPMC-W6003-03	3
	JEPMC-W6003-05	5
	JEPMC-W6003-10	10
	JEPMC-W6003-20	20
	JEPMC-W6003-30	30
	JEPMC-W6003-40	40
	JEPMC-W6003-50	50
MECHATROLINK Cable USB connector to loose wires	JEPMC-W6011-A5	0.5
	JEPMC-W6011-01	1
	JEPMC-W6011-03	3
	JEPMC-W6011-05	5
	JEPMC-W6011-10	10
	JEPMC-W6011-20	20
	JEPMC-W6011-30	30
	JEPMC-W6011-40	40
	JEPMC-W6011-50	50
Terminator (Terminating resistor) 130 Ω	JEPMC-W6022	—



If there is transmission problems such as noise interference, use a cable with ferrite core.

(c) Cable Appearance

- MECHATROLINK cables
Model: JEPMC-W6000-□□, JEPMC-W6002-□□



- Model: JEPMC-W6001-□□, JEPMC-W6003-□□

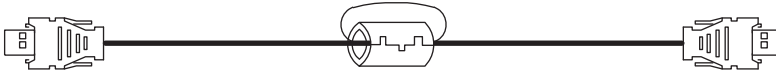

- Model: JEPMC-W6010-□□, JEPMC-W6011-□□



- USB terminator
Model: JEPMC-W6020, JEPMC-W6022

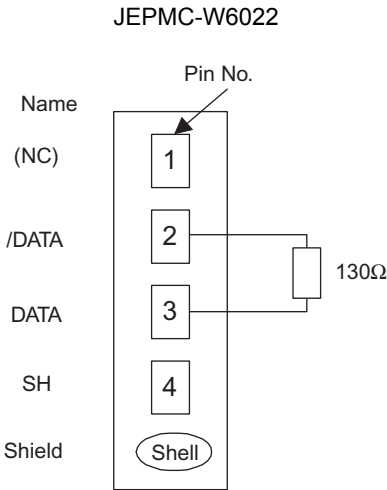
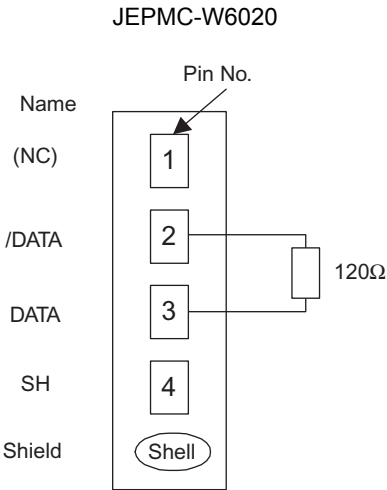

IMPORTANT

- Use the MECHATROLINK standard cables.
- The cables and terminators for MP900 and those for MP2000 must not be mixed together.

(2) Internal Cable Connections

The following figure shows the internal connections for the cables with USB connectors at both ends between the Modules.

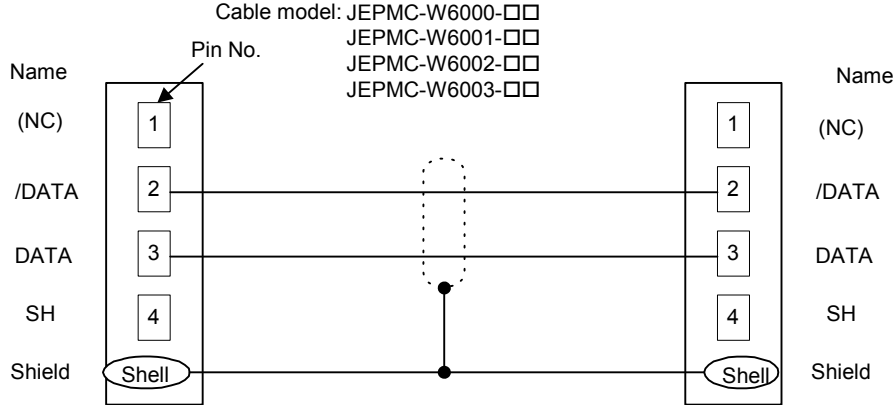

The following figure shows the SGD-□□□N and SGDB-□□□AN SERVOPACK connections to the Master Module.

(a) For MP900 Series

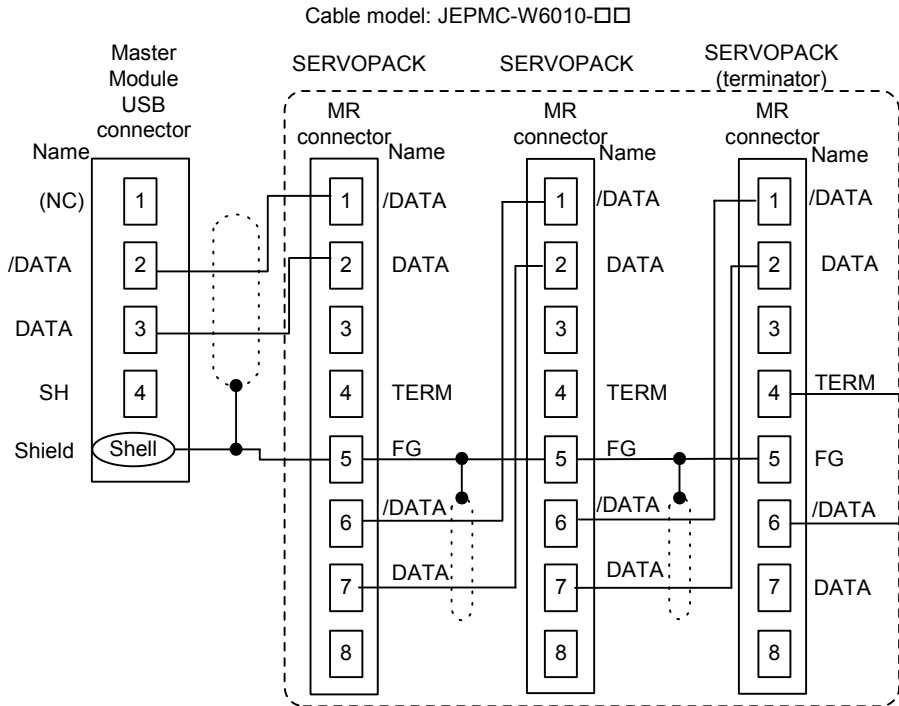

Note: Red lead: DATA
 Black lead: /DATA

(b) For MP2000 Series

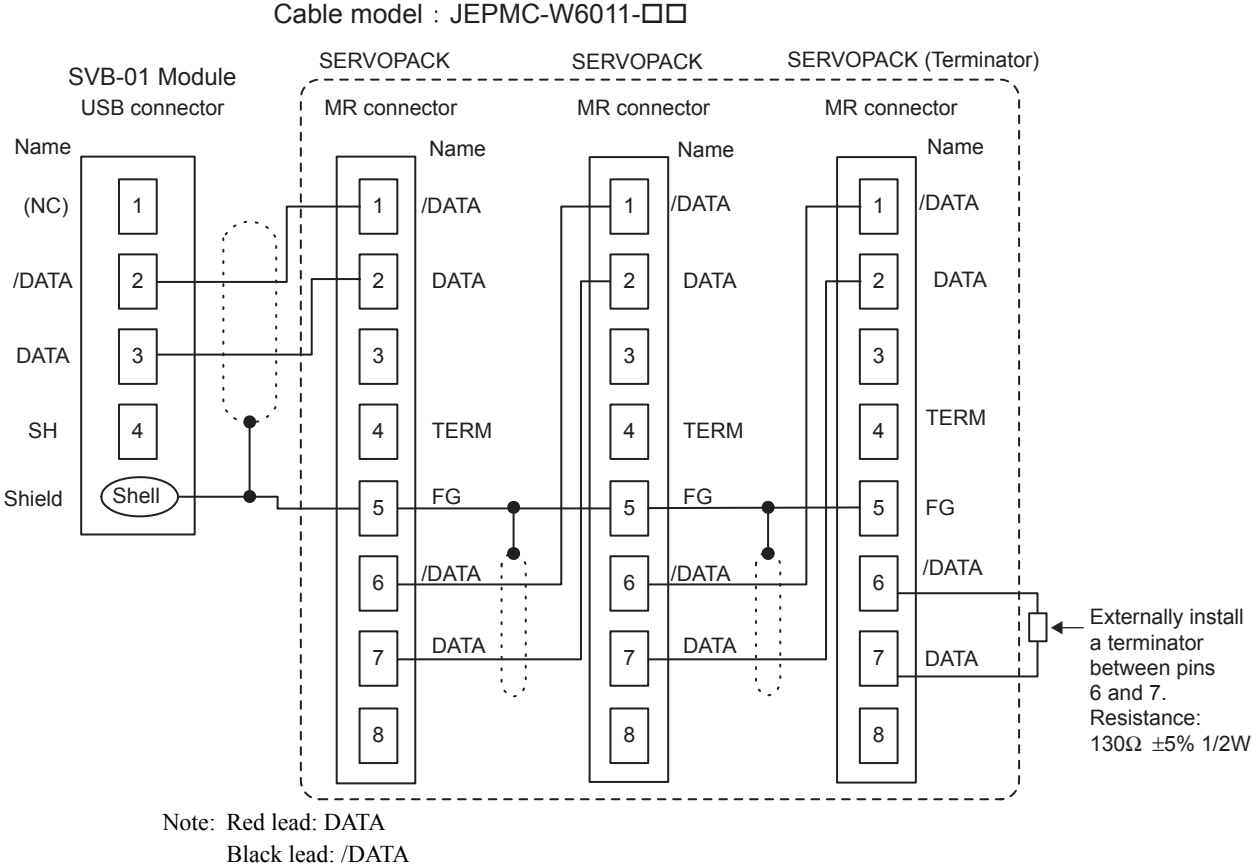

IMPORTANT

- JEPMC-W6010-□□ has an USB connector on one end and a loose wire on the other end. Create the 1:N cable connection using the MR connector and the wire material.
- For a MP2000-series system with a SGD-□□□N or SGDB-□□AN at the terminal, install a terminator of 130Ω
- Normally, you can also wire the shield as specified in the SERVOPACK manual, but if combining the shield with the MP900/MP2000 series, we recommend the connection as shown in the above diagram.
- Connect the cables in accordance with the MECHATROLINK-I specifications. The cable connections out of the specifications causes reflected waves, resulting in erroneous communications.
Total network length: 50 m max.
Distance between stations: 0.3 m min.

9.1.3 Connection Example

(1) MP910 Connection Example

A connection example for a system using the MP910 is shown below.

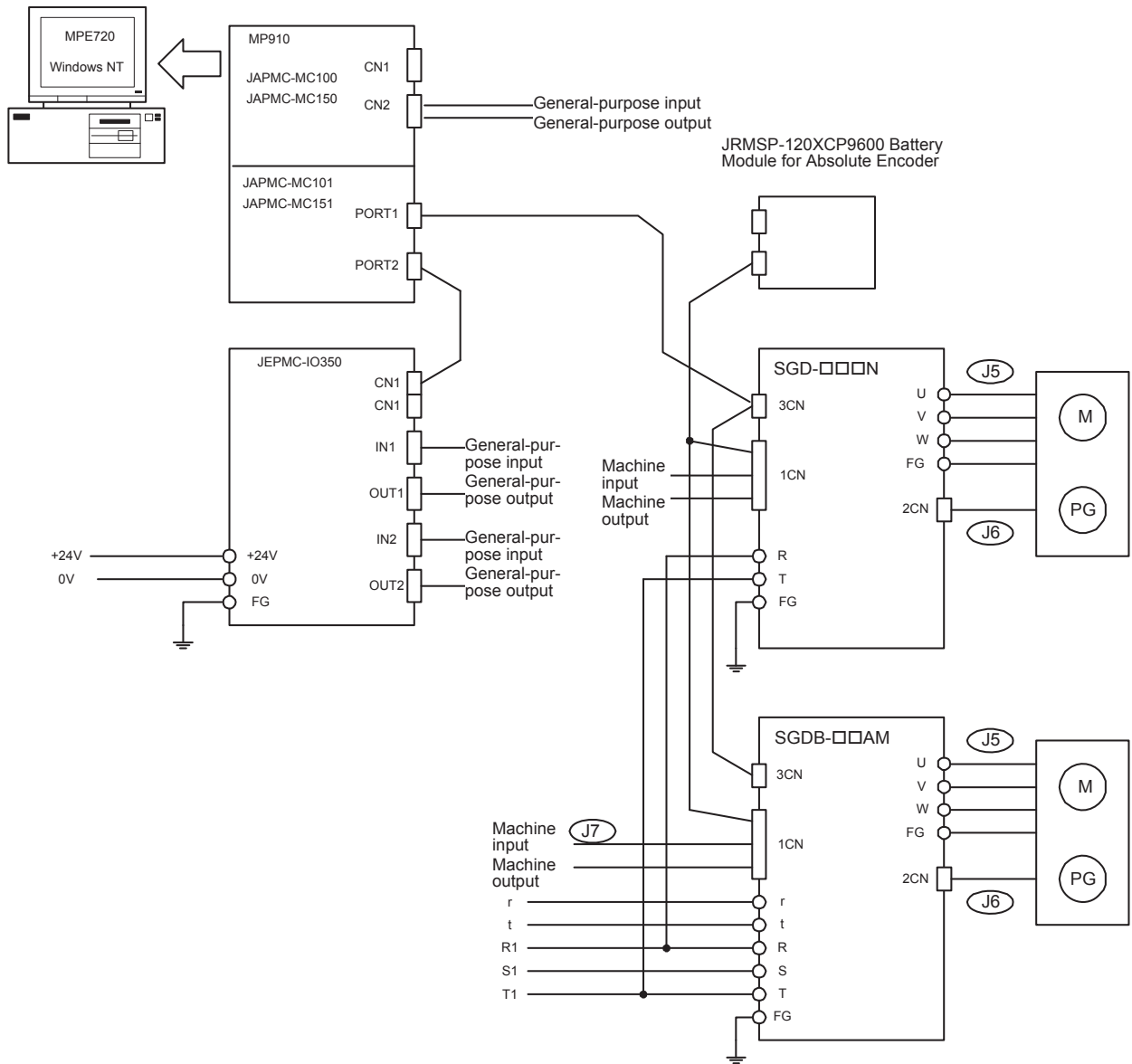

(2) MP920 (SVB-01) Connection Example

A connection example for a system using the SVB-01 is shown below.

(a) Connecting MECHATROLINK Devices

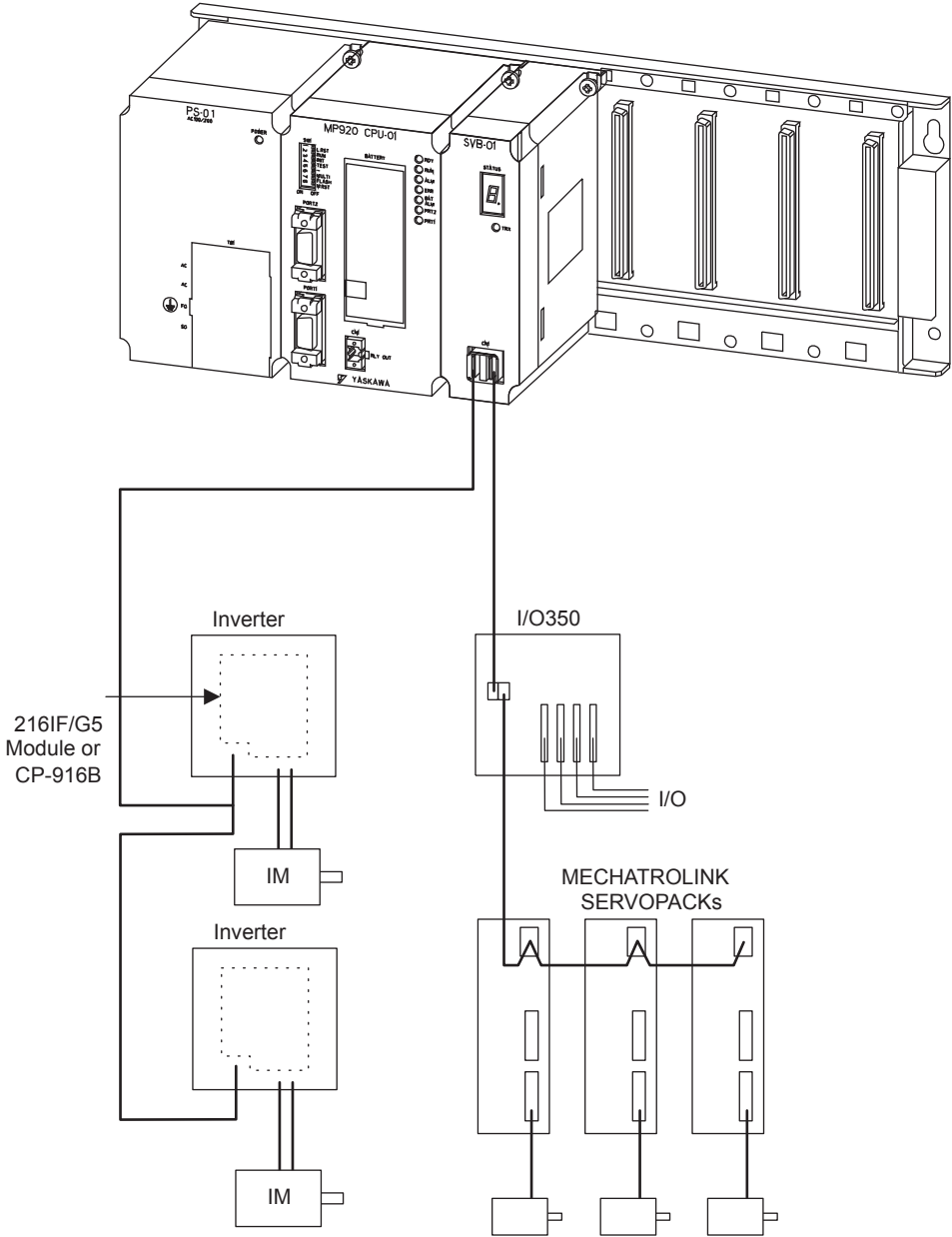

IMPORTANT

There are two connectors on the SVB-01 Module, but only one input port on MECHATROLINK. Both right and left sides of the connector are the same, so it does not matter which side you connect. A maximum of 14 stations can be connected.

(b) Connecting an IO350 Unit to an SVB-01 Module

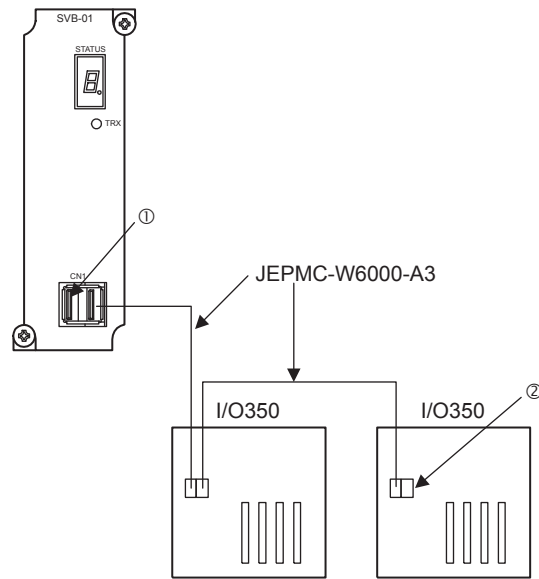

- If connecting an IO350 Unit to an SVB-01 Module, or an IO350 Unit to an IO350 Unit, use a JEPMC-W6000-A3 Standard Cable.

IMPORTANT

Make sure to insert a JEPMC-W6020 USB Terminator into the terminal connector (① and ② in the above diagram).

Refer to 9.1.2 *MECHATROLINK Cables* for appearance and internal connection diagrams.

(c) Connecting Multiple MECHATROLINK SERVOPACKs

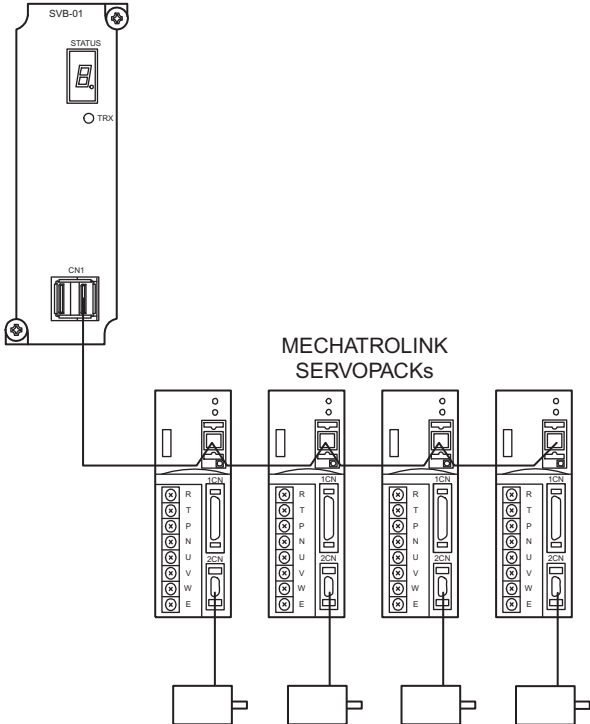

Create the connection between the SVB-01 Module and MECHATROLINK SERVOPACKs such as SGD-□□□N and SGDB-□□AN using the JEPMC-W6010-□□ Standard Cables, MR Connectors, and wiring material, as shown below.

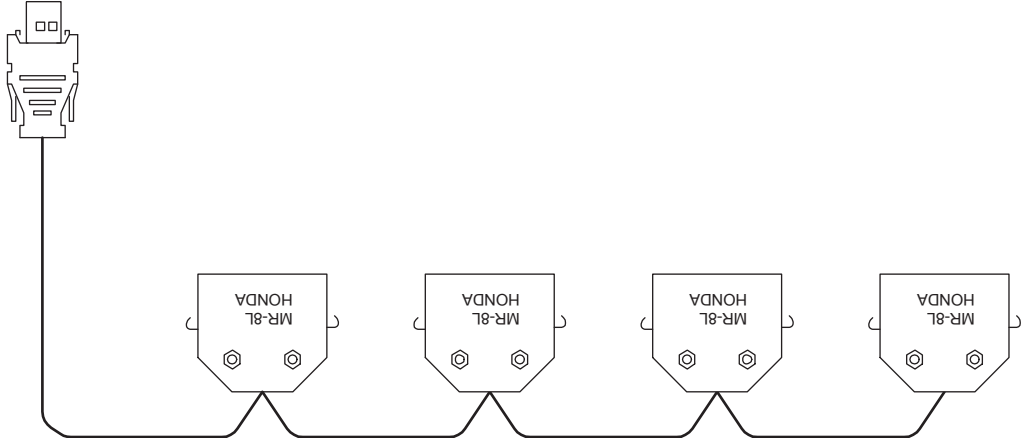

- Refer to 9.1.2 MECHATROLINK Cables for appearance and internal connection diagrams.

(3) MP930 Connection Example

Connect the MC Unit to the I/O Unit, and the I/O Unit to the SERVOPACKs using the following MECHATROLINK cables.

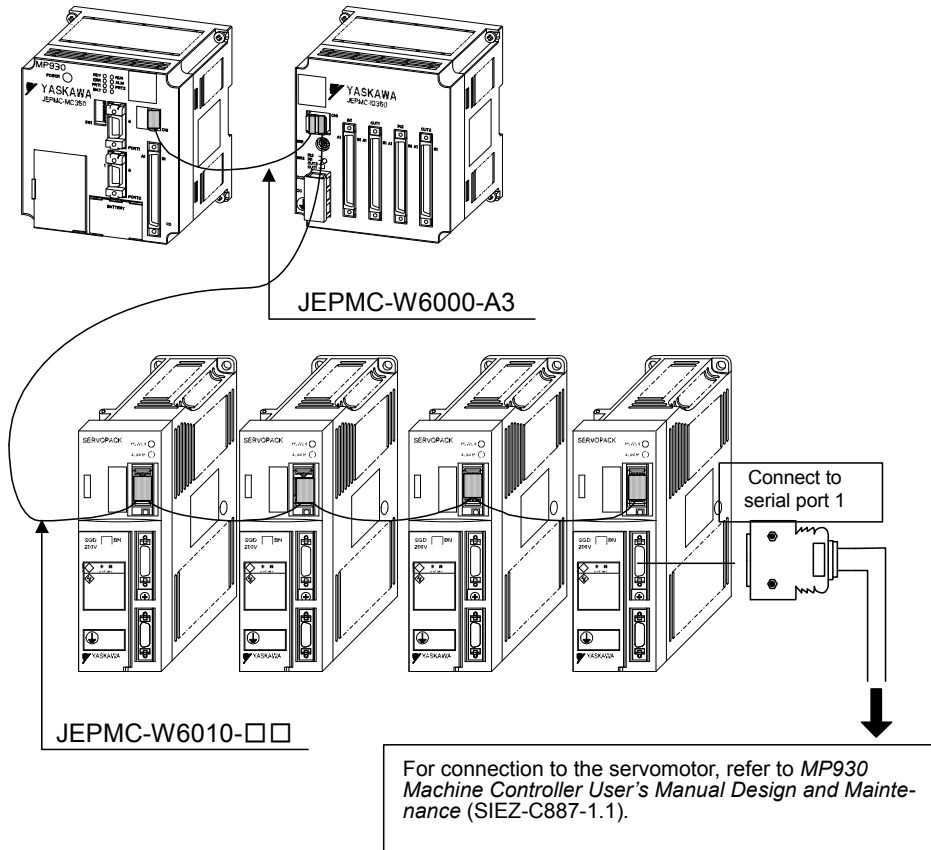

Set the SERVOPACK and I/O Unit station numbers according to the MECHATROLINK settings.

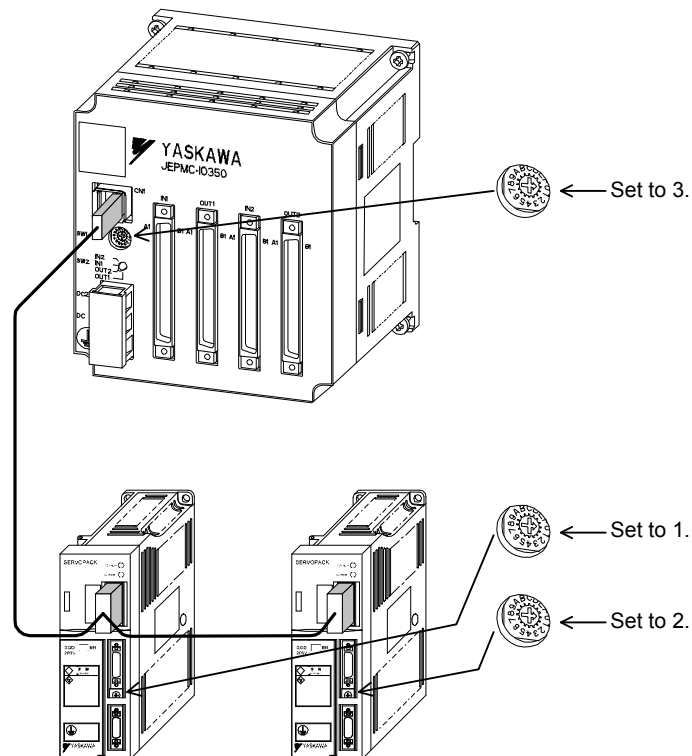

(4) MP940 Connection Example

(a) Connecting an MP940 to an I/O Unit

A connection example for the MP940 Machine Controller and a network-compatible I/O Module is shown below.

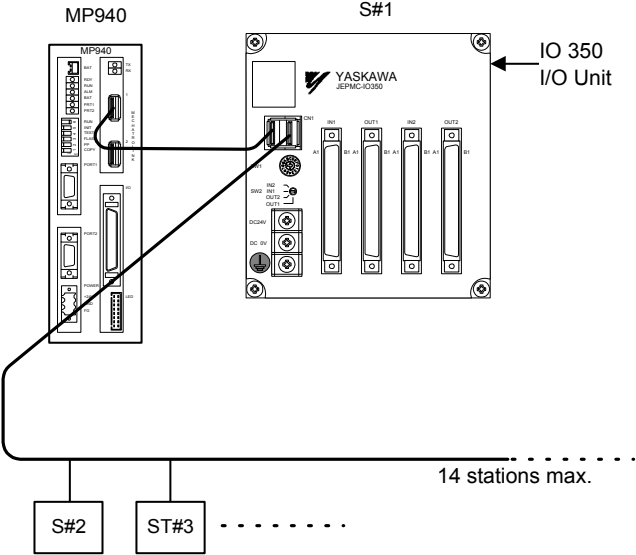

The following example shows how to connect two IO350 Units to an MP940 Module.

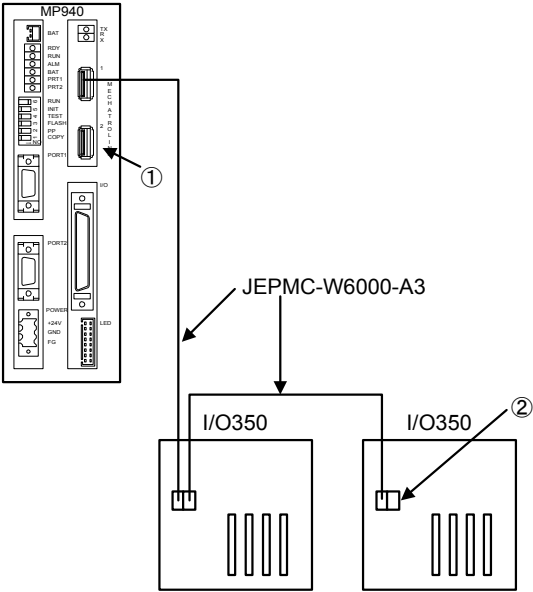

If connecting an IO350 Unit to an MP940 Module, or an IO350 Unit to an IO350 Unit, use a JEPMC-W6000-A3 Standard Cable.

IMPORTANT

Make sure to insert a JEPMC-W6020 USB Terminator into the terminal connector (① and ② in the above diagram). Refer to 9.1.2 MECHATROLINK Cables for appearance and internal connection diagrams.

(b) Using an MP940 as the Master Station

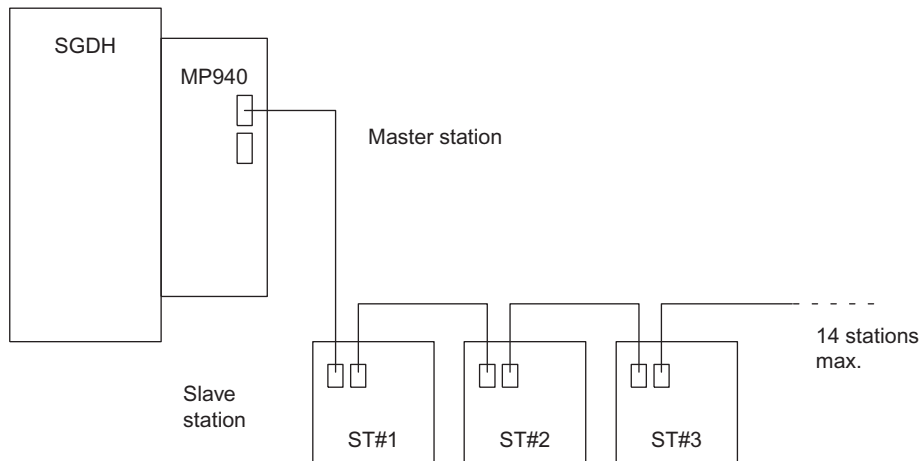

IMPORTANT

- Simple I/O is the only function supported by the MECHATROLINK MP940. You cannot connect a MECHATROLINK Servo or 216IF Inverter.
- For connectable slaves, refer to *1.2 MECHATROLINK System Configuration*.

(c) Using an MP940 as a Slave

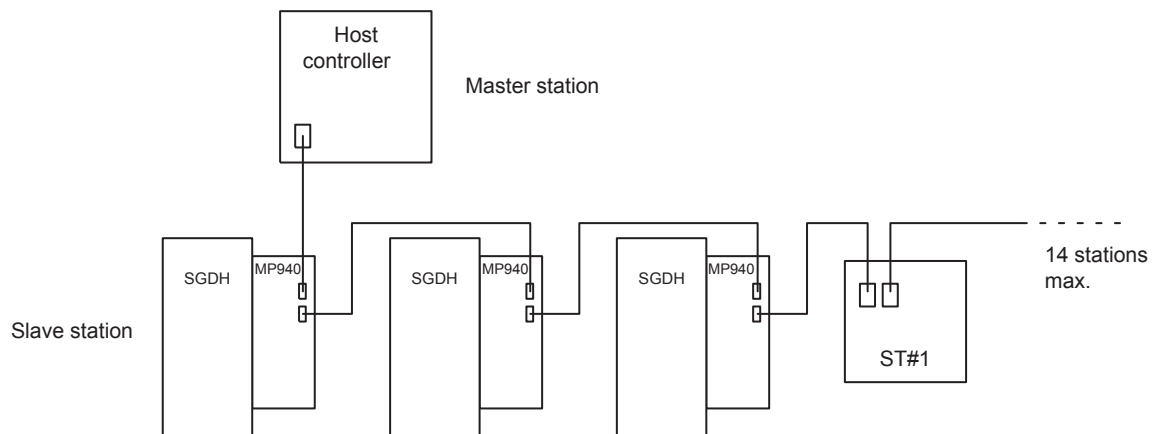

IMPORTANT

If you select an MP940 as a slave, you cannot connect an IO350, Distributed I/O Unit, or other such devices.

9.2 External Wiring

This section explains the external wiring.

9.2.1 Wiring in a Panel

As shown below, separate the communication cable from other wiring, and wire the communication cable separately.

(1) Separation from Low-voltage Cables

Keep the communication cable completely separate from the low-voltage cable (recommended distance: 100 mm min.)

(2) Separation from Operation Circuit Cables

Keep the communication cable completely separate from the low-voltage cable (recommended distance: 100 mm min.)

(3) Separation from Main Circuit Cables

Keep the communication cable completely separate from the main circuit cables (refer to the table below), or shield the main circuit cables.

Table 9.1 Recommended Separation Distance

Main Circuit	Recommended Distance
125 V, 10 A	300 mm min.
250 V, 50 A	450 mm min.
440 V, 200 A	600 mm min.
3 to 6 kV, 800 A	1,200 mm min.

9.2.2 Indoor Wiring Between Panels

This section explains how to separate the wiring when wiring between panels indoors.

- Pass the communication cable independently through a metal conduit or metal duct with no other wiring before installation.

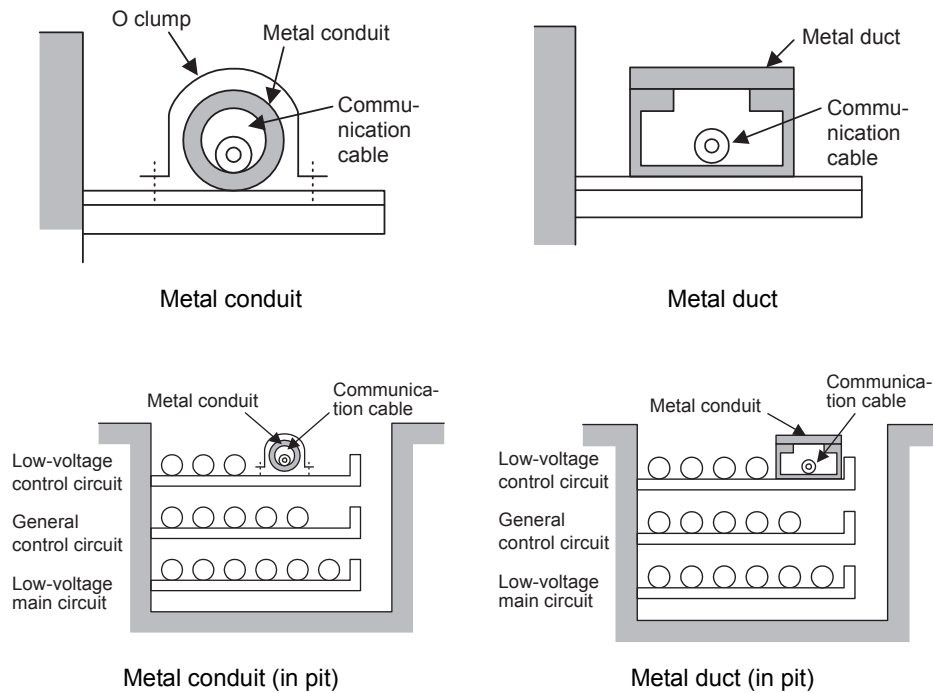

Fig 9.1 Laying the Communication Cable

- Make sure to ground both ends of the metal conduit or metal duct, and also ground as many points as possible in between.

9.2.3 Outdoor Wiring Between Panels

⊘ PROHIBITED

- Each Module is not protected against lightning surge. Do not employ overhead wiring. There is a risk of device damage due to lightning.

(1) Laying the Communication Cable

For laying the communication cable, refer to 9.2.2 *Indoor Wiring Between Panels*. Pay particular attention to the following points.

- If laying the communication cable outdoors, make sure to lay it along overground structural elements, such as a steel framing.

If there are no overground structural elements, lay the cable through an underground pit or underground tunnel, or lay an underground railing or similar structure.

The following diagram shows an example of laying a communication cable between buildings.

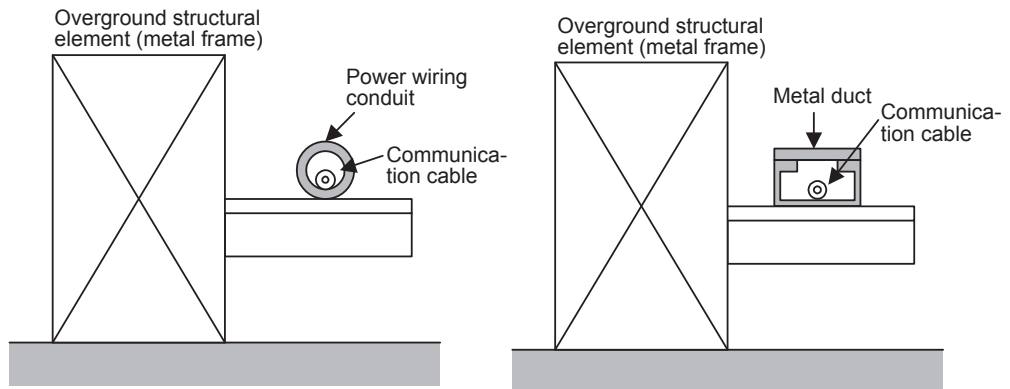

Fig 9.2 Laying the Cable Alongside Structural Elements

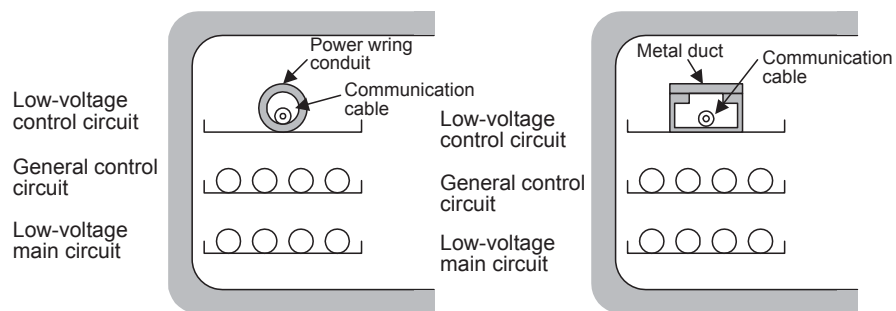

Fig 9.3 Wiring Using an Underground Pit or Underground Tunnel

- Do not string the bare communication cable overhead, because it may pick up inductive noise from airborne electrical waves, resulting in communication errors.

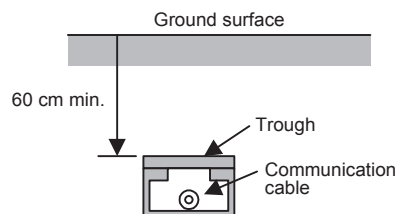

Fig 9.4 Laying the Communication Cable Underground

9.2.4 Grounding

- Grounding Method

(a) Mounting the Device

For the mounting base to which to mount the PLC Modules, use a base (frame) that is of one-piece metal construction.

(b) Ground Wire

Install an “E” terminal for grounding to the control panel, and then connect terminal E to the control panel case. Next, connect terminal E to terminal FG on the Power Supply Module.

Make sure to use a ground wire that is 8 mm² minimum (8 AWG) between terminal E and the ground pole, and make the wiring as short as possible.

If the distance of the wiring to the ground pole is long, use a thicker ground wire to make sure that the sum total of the grounding resistance and the ground wire resistance is maintained at 100 Ω.

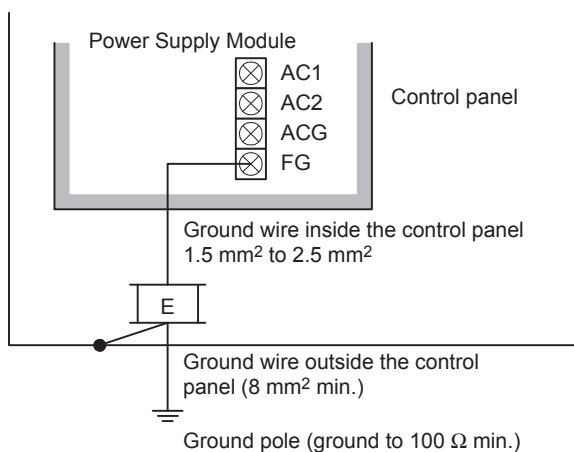

Fig 9.5 Ground Wiring

(c) Ground Pole

Install the ground pole as close as possible to the control panel controlling the PLC, and as far as possible (15 m min.) from the ground poles for other power panels (Group B in the following table).

Make sure the grounding resistance is 100 Ω max.

(d) Shared Ground

As a rule, ground each PLC independently. If the ground wire and ground pole need to be shared with other control panels, however, refer to the following table.

Table 9.2 Shared Ground Wires and Ground Poles

Classification	Compatible Devices	Shared Ground
Group A	Computer panels, instrument control panels, I/O relay panels, general control circuits, etc.	Possible
Group B	High-voltage main control panels, high capacity thyristors, etc.	Not possible

(e) Communication Cables

Use a both-end ground for the communication shield cable.

(f) Metal Power Wire Conduit and Metal Ducts

Make sure to ground both ends of the metal power wire conduit or metal duct, and also ground as many points as possible in between.

9.2.5 Grounding Control Panels

(1) Grounding Power Panels

Do not mount PC panels side-by-side with power panels (refer to Group B in the table on the preceding page). If grounding PC panels near power panels is unavoidable, ground the PC panel as far as possible from the power panel (60 cm min.), and separate as far as possible the ground wire and ground pole for each.

Make sure the ground wires are separated by 60 cm minimum, and that the ground poles are separated by approximately 15 m.

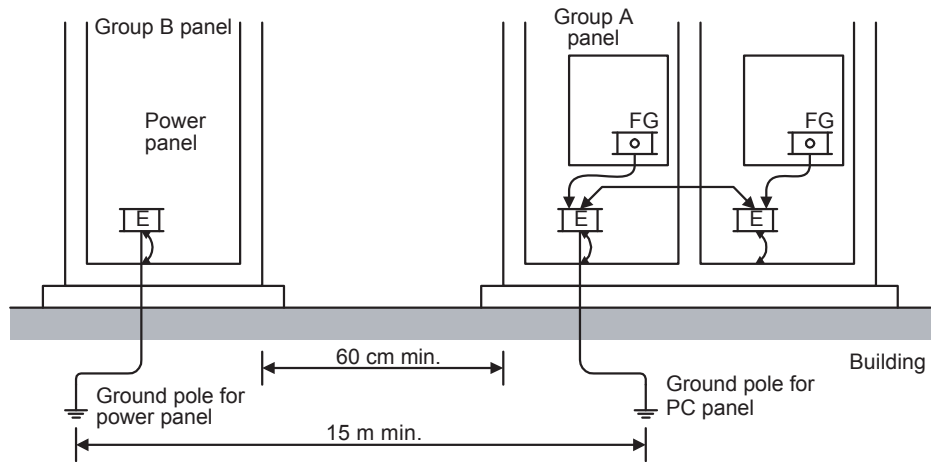

Fig 9.6 Separation from Power Panel

(2) Side-by-side Mounting with Other Control Panels

You can mount PC panels next to the Group A panels listed in the table on the previous page.

If mounting panels side-by-side, however, the control panels pass power using a channel base, so to make sure of the grounding, connect a wire that is 8 mm² minimum between the E Terminals on the control panels.

Next, wire a ground pole to one of the E terminals.

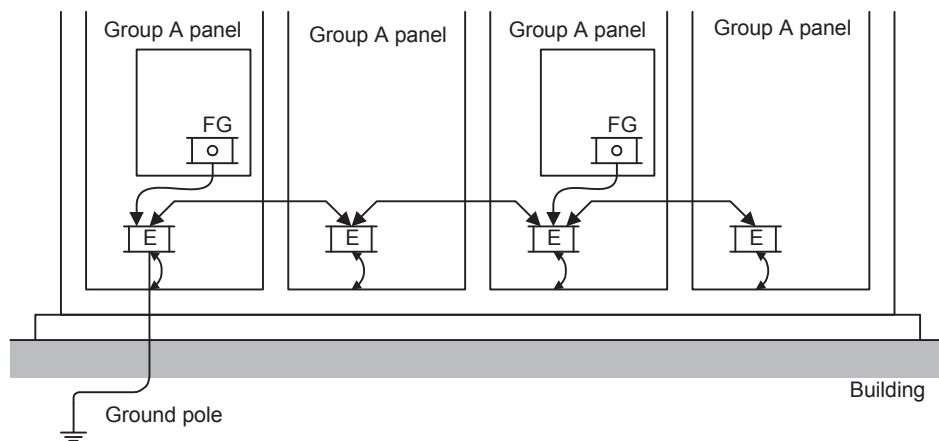

Fig 9.7 Mounting Group A Panels Side-by-side

(3) PC Panel Isolation

If grounding the PC panel to a steel-framed building, the PC panel will be grounded via the building, but this does not normally hinder the panel from functioning.

If the PC panel is located close to a power panel, however, ground each control panel on the PC panel separately to the building to prevent ground noise due to the ground current from the power panel.

Connect terminal E on the PC panel to the special ground pole for the PC panel.

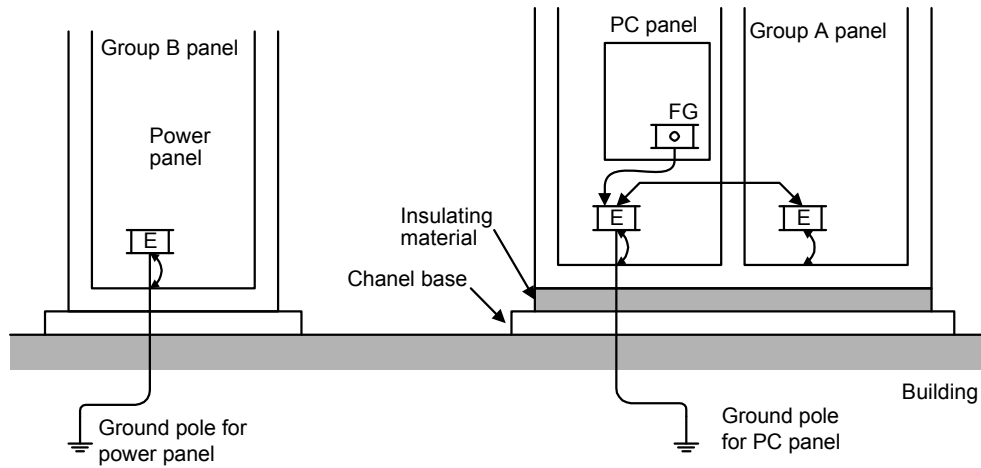

Fig 9.8 PC Panel Isolation

Appendix A

Dimension Diagrams of the Modules

This chapter provides the dimension diagrams of the modules corresponding to the MECHATROLINK systems.

A.1 I/O Modules	A-2
A.1.1 64-point I/O Module	A-2
A.1.2 Relay Contact 8-point Output Module	A-2
A.1.3 100-VAC 8-point Input Module	A-3
A.1.4 200-VAC 8-point Input Module	A-3
A.1.5 100/200-VAC 8-point Output Module	A-4
A.1.6 24-VDC 8-point I/O Module	A-4
A.1.7 24-VDC 16-point Input Module	A-5
A.1.8 24-VDC 16-point Output Module	A-5
A.1.9 Analog Input Module (± 10 V, 4 Channels)	A-6
A.1.10 Analog Output Module (± 10 V, 2 Channels)	A-6
A.2 Reversible Counter Module with Preset Function	A-7
A.3 Pulse Output Module	A-8
A.4 MECHATROLINK-II Repeater	A-9

A.1 I/O Modules

This section shows the external appearances of the Digital I/O Modules.

A.1.1 64-point I/O Module

Model Number: JEPMC-IO350

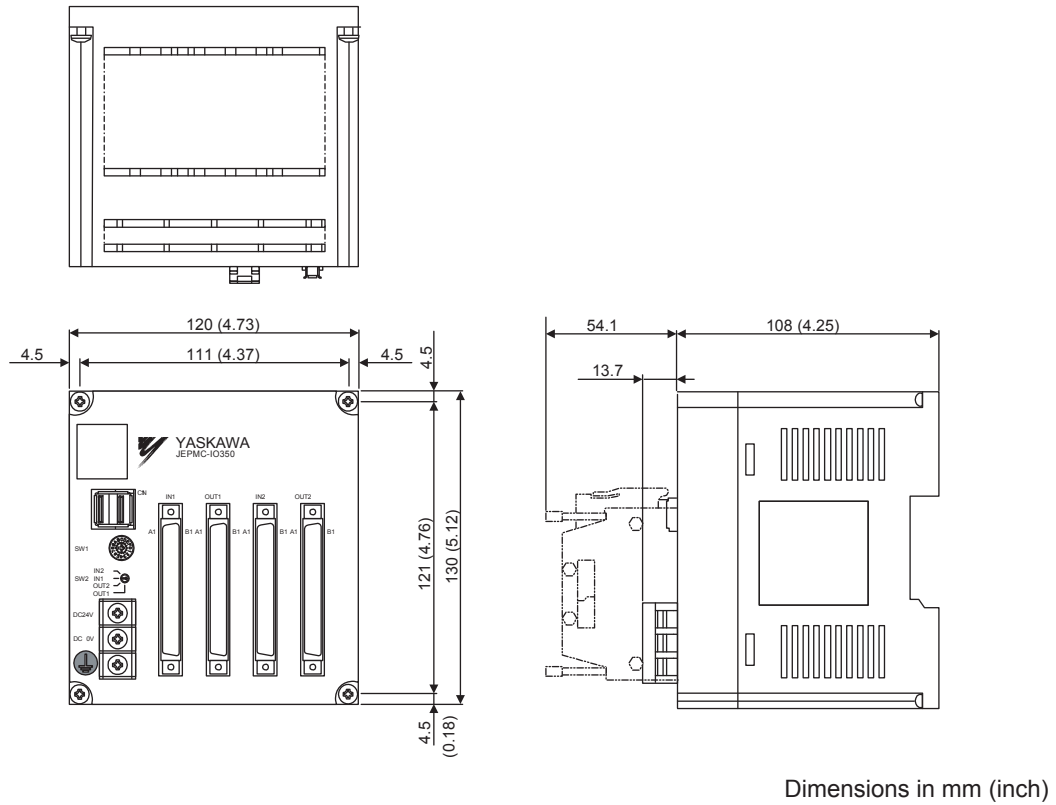

A.1.2 Relay Contact 8-point Output Module

Model Number: JAMSC-120DRA83030/JAMSC-IO2950-E

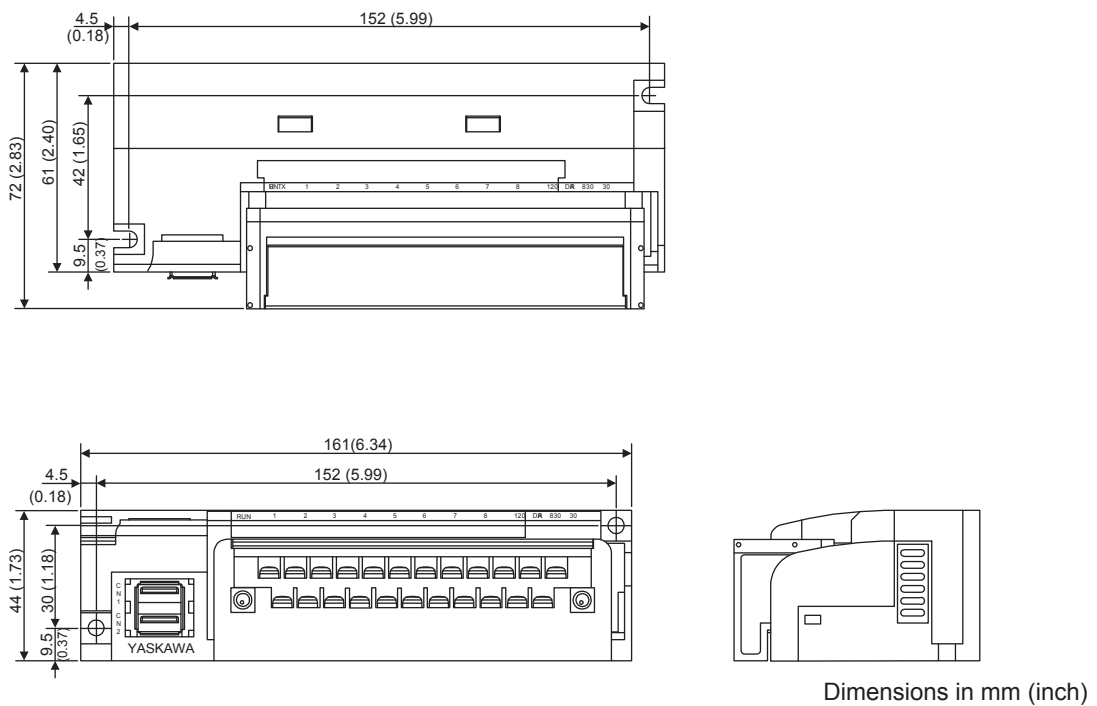

A.1.3 100-VAC 8-point Input Module

Model Number: JAMSC-120DAI53330

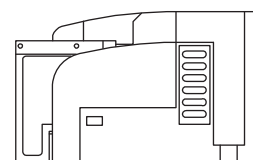
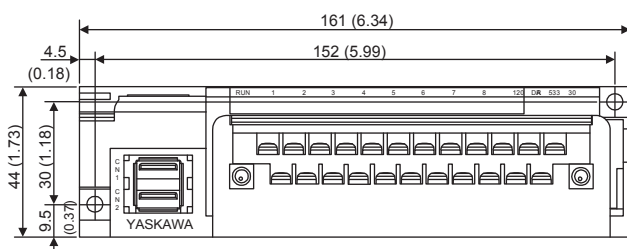
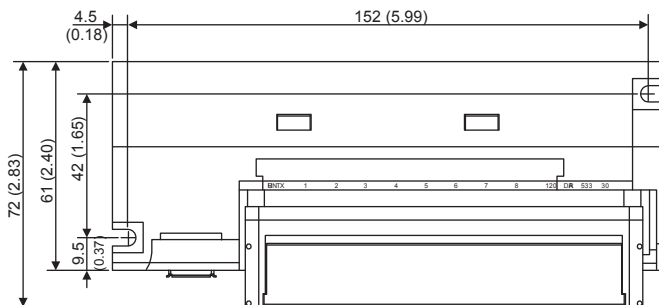

Dimensions in mm (inch)

A.1.4 200-VAC 8-point Input Module

Model Number: JAMSC-120DAI73330

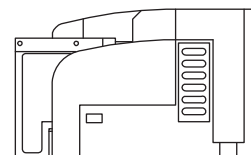
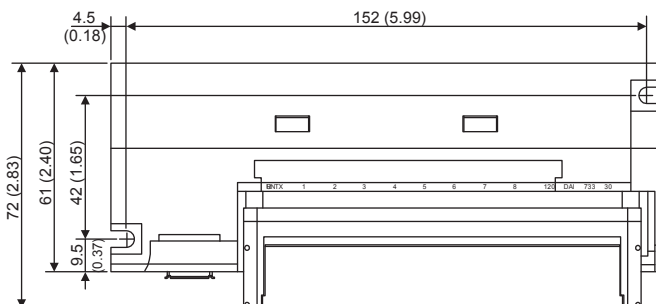

Dimensions in mm (inch)

A.1.5 100/200-VAC 8-point Output Module

A.1.5 100/200-VAC 8-point Output Module

Model Number: JAMSC-120DAO83330

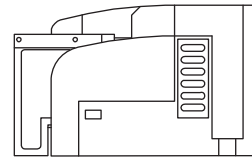
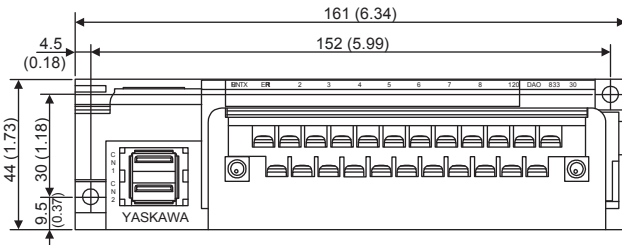
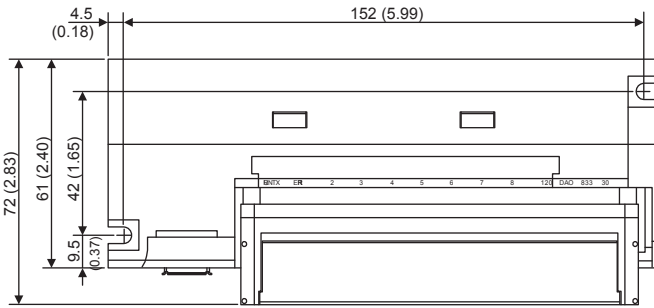

Dimensions in mm (inch)

A.1.6 24-VDC 8-point I/O Module

Model Number: JAMSC-IO2920-E

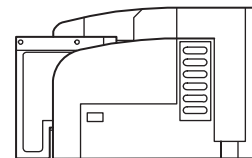
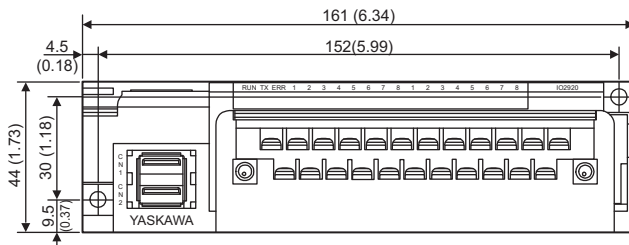
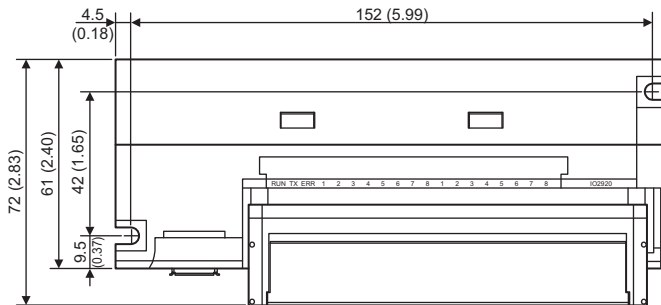

Dimensions in mm (inch)

A.1.7 24-VDC 16-point Input Module

Model Number: JAMSC-120DDI34330/JAMSC-IO2900-E

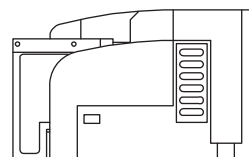
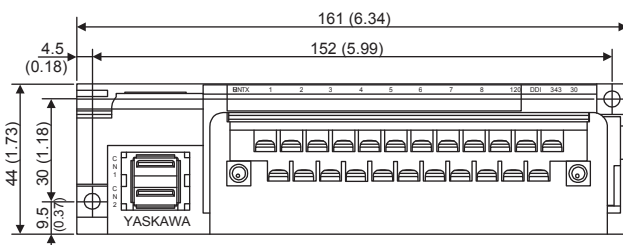
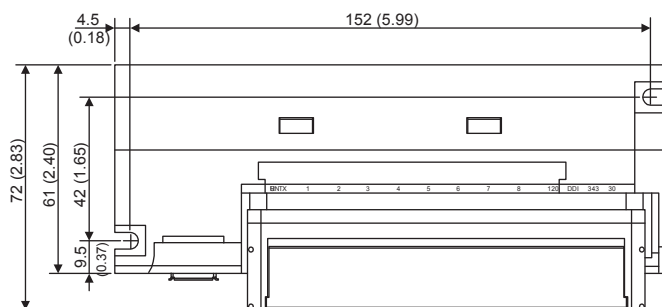

Dimensions in mm (inch)

A.1.8 24-VDC 16-point Output Module

Model Number: JAMSC-120DDO34340/JAMSC-IO2910-E

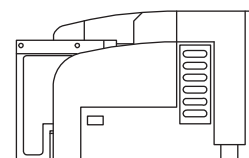
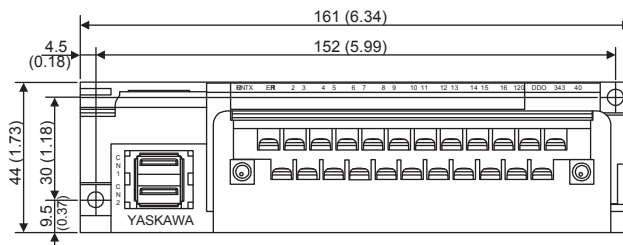
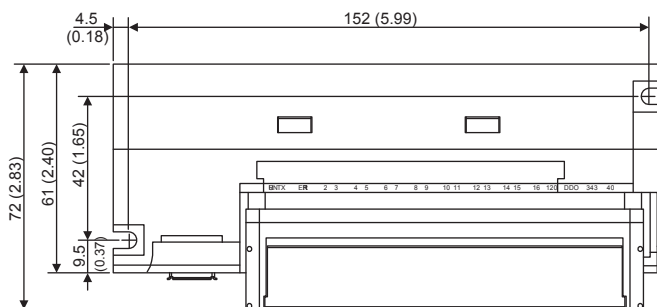

Dimensions in mm (inch)

A.1.9 Analog Input Module (± 10 V, 4 Channels)

A.1.9 Analog Input Module (± 10 V, 4 Channels)

Model Number: JAMSC-120AVI02030/JEPMC-AN2900

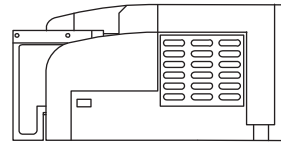
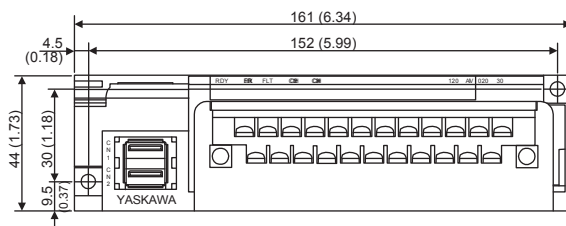
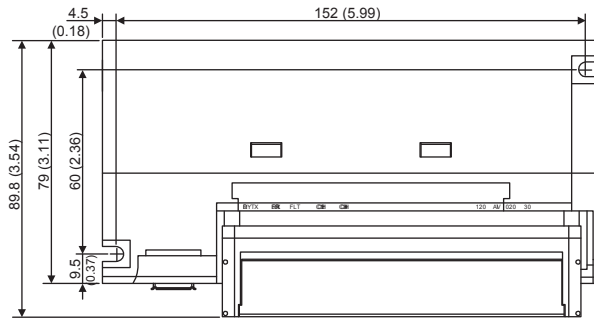

Dimensions in mm (inch)

A.1.10 Analog Output Module (± 10 V, 2 Channels)

Model Number: JAMSC-120AVO01030/JEPMC-AN2910

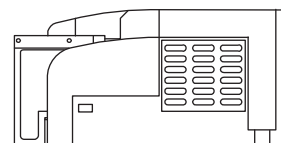
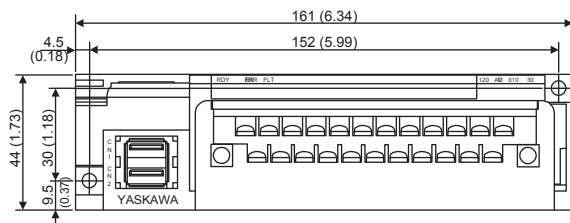
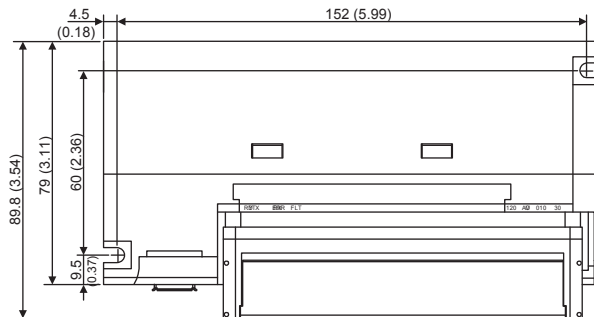

Dimensions in mm (inch)

A.2 Reversible Counter Module with Preset Function

This section shows the external appearances of the Reversible Counter Module with Preset Function.

Model Number: JAMSC-120EHC21140/JEPMC-PL2900

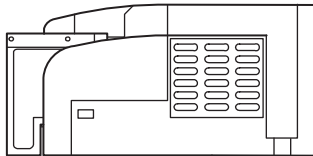
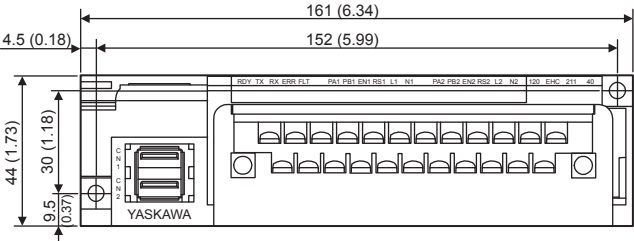
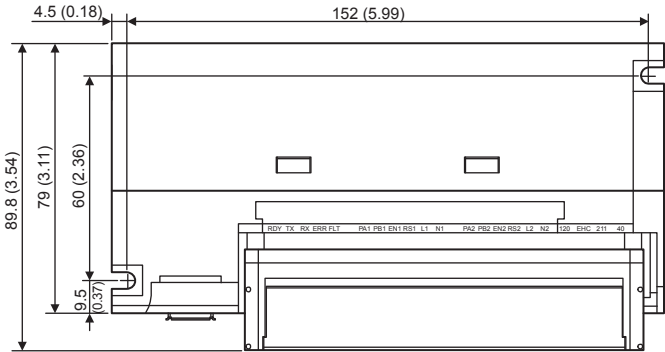

Dimensions in mm (inch)

A.3 Pulse Output Module

This section shows the external appearances of the Pulse Output Modules.

Model Number: JAMSC-120MMB20230/JEPMC-PL2910

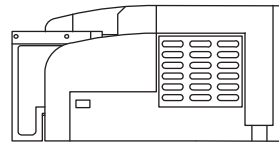
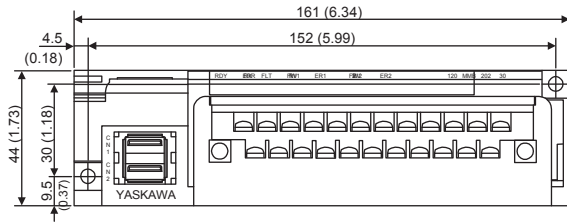
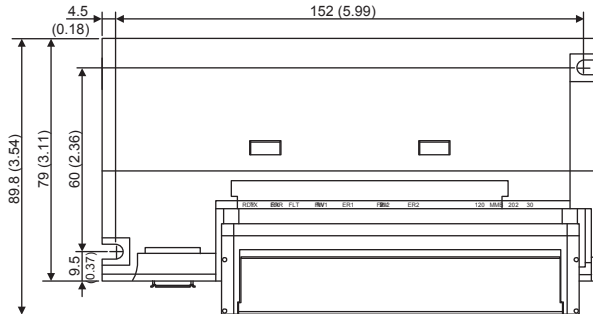

Dimensions in mm (inch)

A.4 MECHATROLINK-II Repeater

This section shows the external appearances of the MECHATROLINK-II Repeaters.

Model Number: JEPMC-REP2000

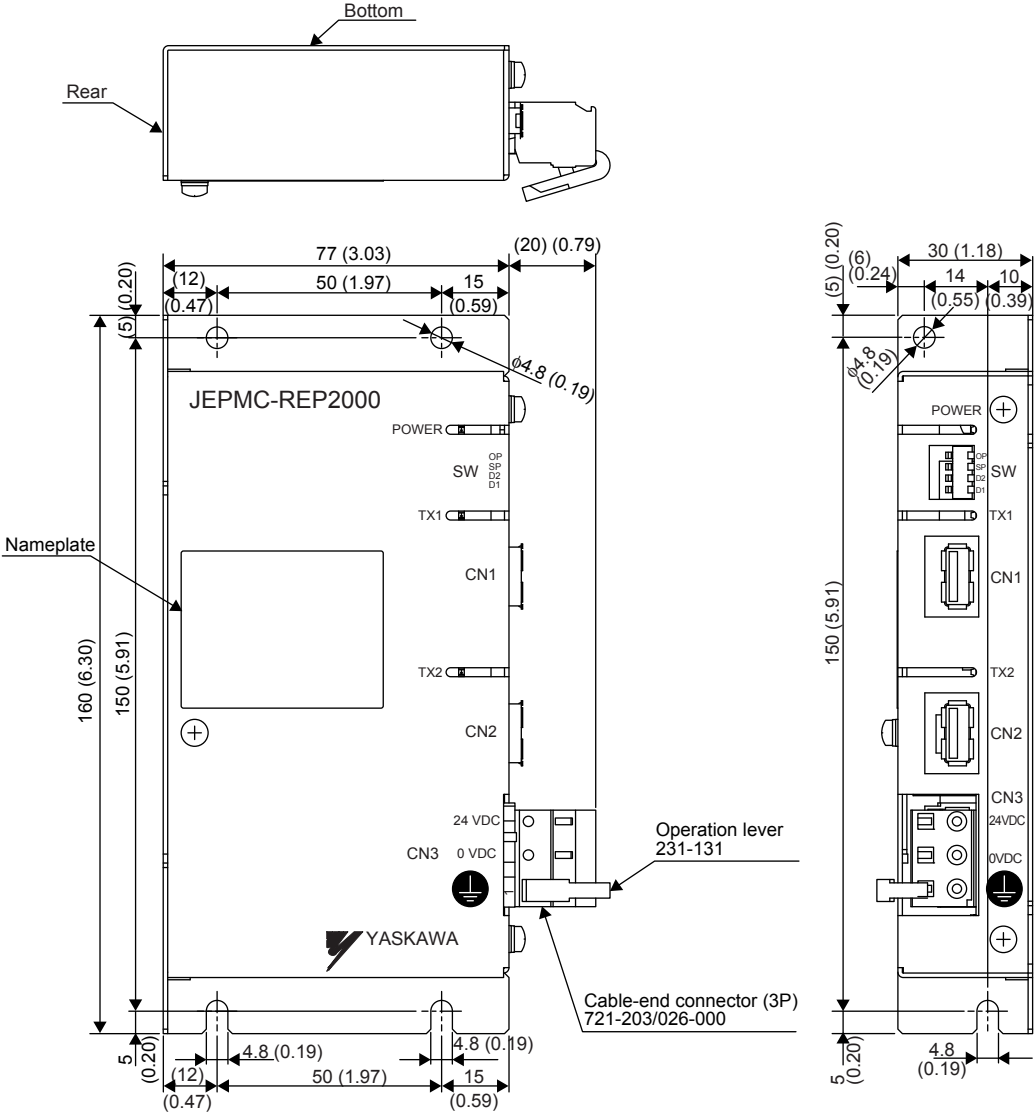

Dimensions in mm (inch)

Appendix B

MECHATROLINK Simple I/O Communications Commands

This chapter provides an overview of the MECHATROLINK Simple I/O communications commands and explains the data link layer.

B.1 Simple I/O Communications Commands	B-2
B.1.1 Overview	B-2
B.1.2 Modules that Support Simple I/O Communications Commands	B-2
B.2 Applicable Commands	B-3
B.3 Data Link Layer Commands	B-4
B.3.1 MDS Command	B-4
B.3.2 CDRW Command	B-6

B.1 Simple I/O Communications Commands

B.1.1 Overview

There are two types of I/Os that are connected to the MECHATROLINK: Simple I/O and Intelligent I/O.

This section describes the specifications of Simple I/O communications commands.

In the Simple I/O communications, I/O services and communications processings are carried out only with hardwares without processor intervention. Therefore, it is connection-less communications. The application layer does not exist, and I/O data are received or transmitted in the data link layer. This type of MECHATROLINK communications specifications is called as MECHATROLINK-DIO.

B.1.2 Modules that Support Simple I/O Communications Commands

The table below lists the modules that support the Simple I/O communications commands.

Classification	Module	Model Number
Distributed I/O Modules	Relay contact Module Wide-voltage, 8-point output	JAMSC-120DRA83030 /JAMSC-IO2950-E
	AC Input Module 100 VAC, 8-point input	JAMSC-120DAI53330
	AC Input Module 200 VAC, 8-point input	JAMSC-120DAI73330
	AC Output Module 100/200 VAC, 8-point output	JAMSC-120DAO83330
	DC I/O Module 24 VDC, 8-point input, 8-point output	JAMSC-IO2920-E
	DC Input Module 24 VDC, 16-point input	JAMSC-120DDI34330 /JAMSC-IO2900-E
	DC Output Module 24 VDC, 16-point output	JAMSC-120DDO34340 /JAMSC-IO2910-E
I/O Modules	64-point I/O Module 24 VDC, 64-point input, 64-point output (sinking)	JEPMC-IO350
	64-point I/O Module 24 VDC, 64-point input, 64-point output (sinking)	JEPMC-IO2310
	64-point I/O Module 24 VDC, 64-point input, 64-point output (sourcing)	JEPMC-IO2330

B.2 Applicable Commands

The table below lists the commands used for the Simple I/O communications.

Code (Hexadecimal)	Commands/ Responses	Direction	Meanings
04	MDS	Master station → Slave station	Reads the ID of a slave station
03	CDRW	Master station → Slave station	Link transmission: Sends the output data of master station.
01	ACK	Slave station → Master station	Positive response to CDRW: At the same time, returns the input data from the slave station.
90	S (0)	Slave station → Master station	Response to MDS: Returns the ID information of the slave station.

The table below shows the relation between commands and responses.

Table B.1 MECHATROLINK I/O Specifications
(Genuine MECHATROLINK I/O Protocol)

Master Station (Commands)		Slave Station (I/O) (Responses)	
MDS (04H)	→	←	S (0) (90H)
CDRW (03H)	→	←	ACK (01H)



The above explained relation between commands and responses does not apply to the I/O module JEPMC-IO350 that had been developed with the old MECHATROLINK protocol I/O specifications: A slave station returns the response S (0) (90H) without ID information (all the fields are set to 0).

Table B.2 NON MECHATROLINK I/O Specifications
(Old MECHATROLINK Protocol I/O Spec)

Primary Station (Commands)		Secondary Station (I/O) (Responses)	
MDS (04H)	→	←	S (0) (90H) Without ID information
CDRW (03H)	→	←	ACK (01H)

B.3 Data Link Layer Commands

The data link layer commands and responses are set in the control field.

There are two types of commands:

- MDS: Reads out the ID.
- CDRW: Refreshes the I/O data.

B.3.1 MDS Command

The table below shows the data format of MDS command.

Table B.3 Data Format of MDS Command

Byte	Command	Response	Remarks
0	MDS (04H)	S (0) (90H)	
1		ID	Refer to • <i>ID Codes</i> on the next page.
2			
3			0 is set in the command data undefined field. 0 is set in the response data undefined field.
4			
5			
6			
7			
8			
9			
10			
11			
12			
13			
14			
15			
16			

• ID Codes

The details of ID code is shown below.

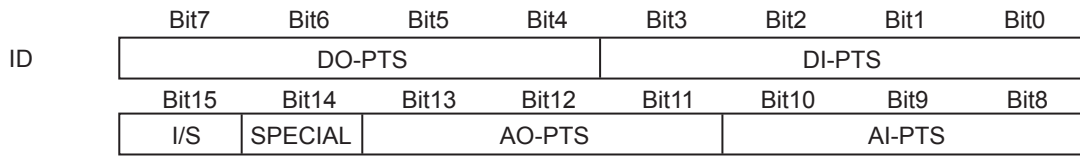

Table B.4 Meaning of Each Bit

Bit No.	Name	Meanings
3 to 0	DI-PTS	Number of discrete input points: See the table below for details.
7 to 4	DO-PTS	Number of discrete output points: See the table below for details.
10 to 8	AI-PTS	Number of analog input (numerical value data input) points: See the table below for details.
13 to 11	AO-PTS	Number of analog output (numerical value data output) points: See the table below for details.
14	SPECIAL	0 Standard
		1 Special
15	I/S	0 Simple I/O (Always 0)

Table B.5 Number of Discrete I/O Points

Bit No. 3 to 0/ 7 to 4	Number of Discrete Input Points	Number of Discrete Output Points	Bit No. 3 to 0/ 7 to 4	Number of Discrete Input Points	Number of Discrete Output Points
0 H	0	0	8 H	For future use	For future use
1 H	4	4	9 H	For future use	For future use
2 H	8	8	A H	For future use	For future use
3 H	16	16	B H	For future use	For future use
4 H	24	24	C H	For future use	For future use
5 H	32	32	D H	For future use	For future use
6 H	64	64	E H	For future use	For future use
7 H	128	128	F H	For future use	For future use

Table B.6 Number of Analog I/O Points

Bit No. 10 to 8/ 13 to 11	Number of Analog Input Points	Number of Analog Output Points
0 H	0	0
1 H	1	1
2 H	2	2
3 H	4	4
4 H	8	8
5 H	For future use	For future use
6 H	For future use	For future use
7 H	For future use	For future use

B.3.2 CDRW Command

The table below shows the data format of CDRW command.

Table B.7 Data Format of CDRW Command

Byte	Command	Response	Remarks
0	CDRW (03H)	ACK (01H)	
1	Output data: Lowest	Input data: Lowest	The array of output data is different from that of input data. Little endian format
2			
3			
4			
5			
6			
7			
8			
9			
10			
11			
12			
13			
14			
15			
16	Output data: Highest	Input data: Highest	

Appendix C

MECHATROLINK Intelligent I/O Communications Commands

This chapter provides an overview of the MECHATROLINK Intelligent I/O communications commands and explains the application layer commands.

C.1 Intelligent I/O Communications Commands	C-2
C.1.1 Overview	C-2
C.1.2 Modules that Support Intelligent I/O Communications Commands	C-2
C.2 Applicable Commands	C-3
C.3 Application Layer Commands	C-4
C.3.1 No Operation: NOP (00H)	C-4
C.3.2 Read ID Command (ID_RD: 03H)	C-6
C.3.3 Read Alarm/Warning Command (ALM_RD: 05H)	C-7
C.3.4 MECHATROLINK Connection Command: CONNECT (0EH)	C-8
C.3.5 DISCONNECTION Command: DISCONNECT (0FH)	C-9
C.3.6 Read/Write I/O Data Command: DATA_RWA (50H)	C-10

C.1 Intelligent I/O Communications Commands

C.1.1 Overview

There are two types of I/Os that are connected to the MECHATROLINK: Simple I/O and Intelligent I/O.

This section describes the specifications of Intelligent I/O communications commands.

The Intelligent I/O carry out connection type communications in accordance with the MECHATROLINK communications specifications.

The Simple I/O carry out connection-less simple MECHATROLINK communications (MECHATROLINK-DIO).

C.1.2 Modules that Support Intelligent I/O Communications Commands

The table below lists the modules that support the Intelligent I/O communications commands.

Classification	Module	Model Number
Distributed I/O Modules	A/D Module analog input -10 to +10V, 4 channels	JAMSC-120AVI02030
	A/D Module analog input -10 to +10V, 4 channels	JEPMC-AN2900
	D/A Module analog output -10 to +10V, 2 channels	JAMSC-120AVO01030
	D/A Module analog output -10 to +10V, 2 channels	JEPMC-AN2910
Counter Modules	Counter Module Reversible counter, 2 channels	JAMSC-120EHC21140
	Counter Module Reversible counter, 2 channels	JEPMC-PL2900
Pulse Output Modules	Pulse Output Module Pulse output, 2 channels	JAMSC-120MMB20230
	Pulse Output Module Pulse output, 2 channels	JEPMC-PL2910
Others	PLC Module MP940	JEPMC-MC400
	Motion Module SVB-01	JAPMC-MC2310
	Machine Vision System MYVIS YV250	JEVSA-YV250

C.2 Applicable Commands

The table below shows the commands used for the Intelligent I/O communications.

Code (Hexadecimal)	Command	Function	Processing Classification	Synchronization Type
00	NOP	No Operation	Network command	Asynchronous commands
03	ID_RD	Read ID	Data communications command	
05	ALM_RD	Read ALARM/WARNING	Data communications command	
0E	CONNECT	MECHATROLINK-II Connection	Network command	
0F	DISCONNECT	Disconnection	Network command	
50	DATA_RWA	Read/Write I/O Data	Data communications command	

C.3 Application Layer Commands

C.3.1 No Operation: NOP (00H)

This command is sent as a no operation command when managing the network.

A slave station returns the current status (ALARM, STATUS) as the response.

(1) Completion Confirmation (Process on Master-side)

The completion of the command execution is confirmed by the response byte 1 = NOP, STATUS, and CMDRDY = 1.

(2) Command Classification

- Group classified by device: Common command group
- Group classified by function: Network command group
- Synchronization classification: Asynchronous command

(3) Data Format

The table below shows the data format of NOP command and response.

Table C.1 Data Format of NOP

Byte	Command	Response	Remarks
0	NOP (00H)	NOP (00H)	–
1		ALARM	See C.3.1 (4) Alarm and Error Codes.
2		STATUS	See C.3.1 (5) STATUS.
3			
4			
5			
6			
7			
8			
9		–	
10			
11			
12			
13			
14			
15	WDT	RWDT	–

(4) Alarm and Error Codes

The following codes are set in the response ALARM when a communications error (detected by a slave station) occurs.

Error Code (Hex)	Name	Description
00	Communication Completed	–
01	Invalid Command	• Command is not supported.
02	Command Not Allowed	• Command inconsistency with communications phase • Command execution conditions not met
03	Invalid Data	The data in the command is not correct. • Outside setting range • Outside allowable range • Not supported • Illegal data in undefined area (must be 0)

(5) STATUS

The bit configuration in the STATUS field is shown below. STATUS indicates the state of the YV250 when the response is sent.

bit7	bit6	bit5	bit4	bit3	bit2	bit1	bit0
–	–	–	–	–	CMDRDY	WARNG	ALARM

bit15	bit14	bit13	bit12	bit11	bit10	bit9	bit8
–	–	–	–	–	–	–	–

(a) ALARM Bit (STATUS Field Bit 0)

- Definition

1: Alarm

0: No alarm

- Description

- The ALARM bit indicates the alarm state of a slave station. The ALARM bit in the STATUS field is set to 1 when an alarm occurs.
- The ALARM bit is set to 0 when the slave station changes from alarm state to normal state.

(b) WARNG Bit (STATUS Field Bit 1)

- Definition

1: Warning

0: Not warning

- Description

- The WARNG bit indicates the warning state of a slave station. The WARNG bit in the STATUS field is set to 1 when a warning occurs.
- The WARNG bit is set to 0 when the slave station changes from warning state to normal state.

(c) CMDRDY Bit (STATUS Field Bit 2)

- Definition

1: Command reception enabled

0: Command being executed

- Description

- When the CMDRDY bit is 0, command processing is in progress. While the CMDRDY bit is 0, the slave station continues process of the current command. The DISCONNECT command will be executed immediately, regardless of the value of CMDRDY.
- The completion of command execution is confirmed using the completion confirmation method for each command.
- The time that the CMDRDY bit is kept at 0 is determined by the slave station product specifications. If this time is exceeded, the C1 master station will detect a command timeout.
- The CMDRDY bit is set to 0 whenever command execution is possible, even if alarm or warning state exists.

C.3.2 Read ID Command (ID_RD: 03H)

This command requests reading the ID of the device. The product information are read out as the ID data. The details of ID data are specified by DEVICE_CODE.

(1) Completion Confirmation (Process of Master Station)

The completion of the command execution is confirmed by the response byte 1 = ID_RD, CMDRDY=1, DEVICE_CODE, OFFSET, and SIZE.

(2) Command Classification

- Group classified by device: Common command group
- Group classified by function: Network command group
- Synchronization classification: Asynchronous command

(3) Data Format

The table below shows the data format of ID_RD command and response.

Table C.2 Data Format of ID_RD

Byte	Command	Response	Remarks
1	ID_RD (03H)	ID_RD (03H)	–
2		ALARM	See C.3.1 No Operation: NOP (00H).
3		STATUS	See C.3.1 No Operation: NOP (00H).
4			
5	DEVICE_CODE	DEVICE_CODE (Copy of command)	DEVICE_CODE: 00H: Product model 01H: Manufacturer's serial number (Not implemented) 02H: Versions (Hardware version - System software version - Boot software version) xxxx - yyyy - zzzz 03H: Vendor code (Not implemented) OFFSET: ID read offset SIZE: Read data size (1 to 8 bytes)
6	OFFSET	OFFSET (Copy of command)	
7	SIZE	SIZE (Copy of command)	
8		ID	–
9			
10			
11			
12			
13			
14			
15			
16	WDT	RWDT	–

C.3.3 Read Alarm/Warning Command (ALM_RD: 05H)

This command requests reading the alarm or warning state.

An alarm or warning code is set in the response to indicate the current alarm or warning state.

Some codes are overlapped with ALARM of the byte 2.

(1) Completion Confirmation (Process on Master-side)

The completion of command execution is confirmed by the response byte 1 = ALM_RD, and STATUS. CMDRDY = 1

(2) Command Classification

- Group classified by device: Common command group
- Group classified by function: Control command group
- Synchronization classification: Asynchronous command

(3) Data Format

The table below shows the data format of ALM_RD command and response..

Table C.3 Data Format of ALM_RD

Byte	Command	Response	Remarks
1	ALM_RD (05H)	ALM_RD (05H)	–
2		ALARM	See C.3.1 No Operation: NOP (00H).
3		STATUS	See C.3.1 No Operation: NOP (00H).
4			
5		ALM_RD_MODE	ALM_RD_MODE (Copy of command)
6		ALM_DATA (new)	–
7			
8			
9			
10			
11			
12			
13			
14			
15			
16	WDT	RWDT	–

C.3.4 MECHATROLINK Connection Command: CONNECT (0EH)

This command requests opening a MECHATROLINK connection. After the completion confirmation, communications between the master station and the slave station will be possible.

(1) Completion Confirmation (Process on Master-side)

The completion of command execution is confirmed by the response byte 1= CONNECT, STATUS.CMDRDY = 1, and the set data (VER, COM_MODE, COM_TIME).

(2) Command Classification

- Group classified by device: Common command group
- Group classified by function: Network command group
- Synchronization classification: Asynchronous command

(3) Data Format

The table below shows the data format of CONNECT command and response.

Table C.4 Data Format of CONNECT

Byte	Command	Response	Remarks
1	CONNECT (0EH)	CONNECT (0EH)	–
2		ALARM	See C.3.1 No Operation: NOP (00H).
3		STATUS	See C.3.1 No Operation: NOP (00H).
4			
5	VER (= 21H)	VER (Copy of command)	Version VER=21H
6	COM_MODE	COM_MODE (Copy of command)	COM_MODE: For M-I, always 00H (Single transfer asynchronous communications) For M-II (17-byte), always 00H (Single transfer asynchronous communications) For M-II (32-byte), always 80H (Single transfer asynchronous communications, byte 17 to 31 used.)
7	COM_TIME	COM_TIME (Copy of command)	Transmission cycle (ms) The applicable modules support only asynchronous communications, so it is not necessary to set a value.
8			–
9			
10			
11			
12			
13			
14			
15			
16	WDT	RWDT	–

C.3.5 DISCONNECTION Command: DISCONNECT (0FH)

This command requests disconnection. The connection between the C1 master station and the designated slave station will be disconnected. This command has the priority over any other commands. The slave station stops execution of any other command and is disconnected from the master station immediately when receiving this command.

This command can be received in any phase.

(1) Completion Confirmation (Process on Master-side)

The completion of command execution is confirmed by the response byte 1 = DISCONNECT, STATUS CMDRDY = 1. (The confirmation is not compulsory.)

The master station sends this command for 2 transmission cycles or more.

(2) Command Classification

- Group classified by device: Common command group
- Group classified by function: Network command group
- Synchronization classification: Asynchronous command

(3) Data Format

The table below shows the data format of DISCONNECT command and response.

Table C.5 Data Format of DISCONNECT

Byte	Command	Response	Remarks
1	DISCONNECT (0FH)	DISCONNECT (0FH)	–
2		ALARM	See C.3.1 No Operation: NOP (00H).
3		STATUS	See C.3.1 No Operation: NOP (00H).
4			
5			
6			
7			
8			
9			
10			
11			
12			
13			
14			
15			
16			

C.3.6 Read/Write I/O Data Command: DATA_RWA (50H)

This command refreshes I/O data.

(1) Completion Confirmation (Process on Master-side)

The completion of command execution is confirmed by the response byte 1 = DATA_RWS, STATUS.CMDRDY = 1.

(2) Command Classification

- Group classified by device: Common command group
- Group classified by function: Data communications command group
- Synchronization classification: Asynchronous command

(3) Data Format

The table below shows the data format of DATA_RWA command and response.

Table C.6 Data Format of DATA_RWA

Byte	Command	Response	Remarks
1	DATA_RWA (50H)	DATA_RWA (50H)	–
2	OPTION	ALARM	See C.3.1 No Operation: NOP (00H).
3		STATUS	STATUS: See C.3.1 No Operation: NOP (00H).
4			OPTION: Depends on the product specifications
5	OUTPUT data	INPUT data	Physically non-existing I/O data = 0
6			
7			
8			
9			
10			
11			
12			
13			
14			
15			
16			
17			Used for data area in 32-byte mode
18			–
19			
20			
21			
22			
23			
24			
25			
26			
27			
28			
29			
30			
31			

Appendix D

Supplemental Information

This chapter provides information on a network where Simple I/O and Intelligent I/O are used.

D.1 Using Simple I/O and Intelligent I/O Together	D-2
D.1.1 Master Station State Transition Diagram	D-2
D.1.2 Event Matrices	D-3
D.1.3 ID of Intelligent I/O	D-4

D.1 Using Simple I/O and Intelligent I/O Together

This chapter provides information on a network where Simple I/O and Intelligent I/O are connected to Master station.

D.1.1 Master Station State Transition Diagram

The state transition diagram of Master station to which Simple I/Os and Intelligent I/Os are connected.

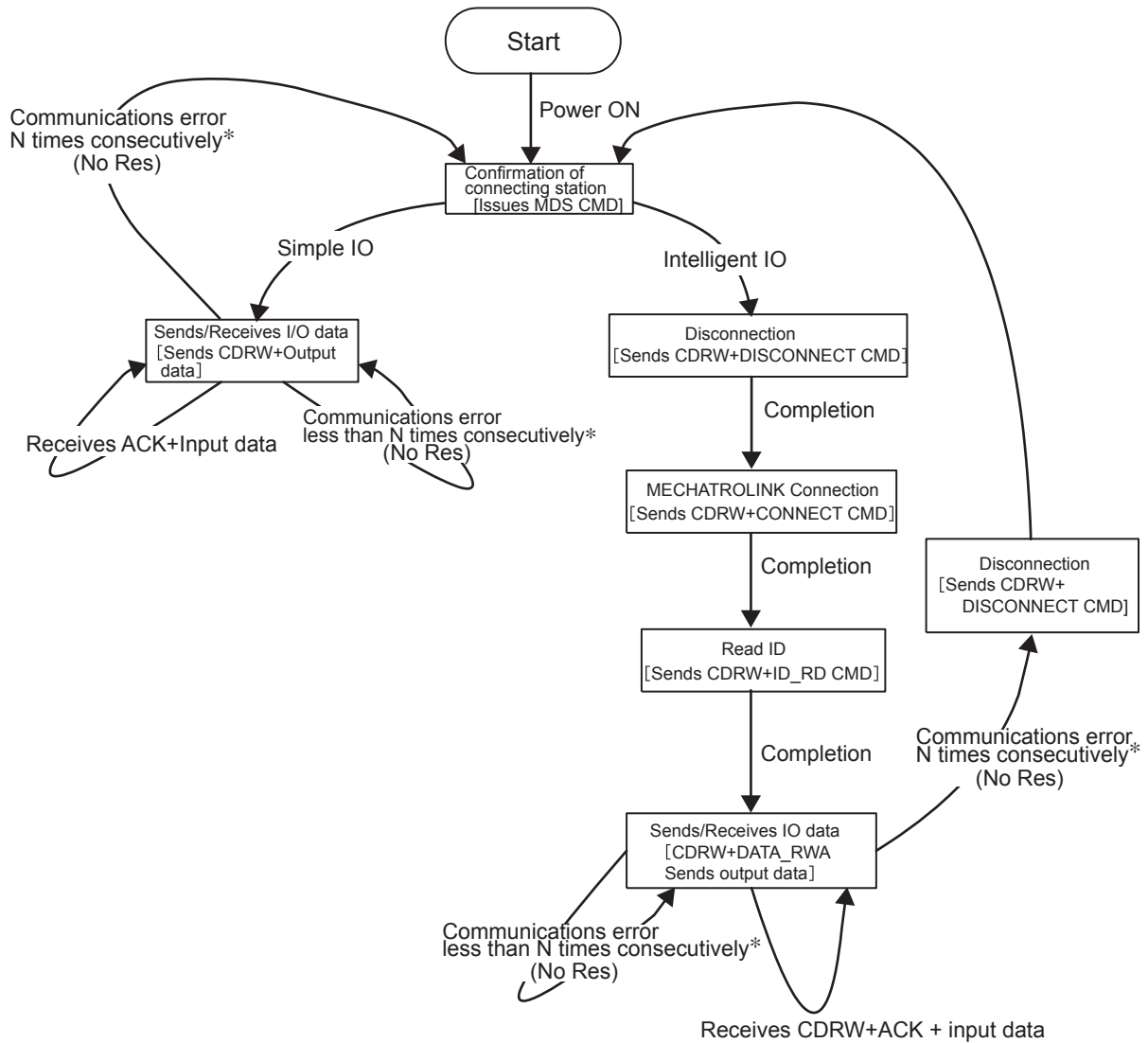

* N (number of times) depends on the product specifications of the master station.

D.1.2 Event Matrices

The event matrices for Simple I/Os and Intelligent I/Os are as shown below.

(1) Event Matrix for Simple I/Os

	Event	Communications Possible	Communications Failed
	Power ON	Initialized state	–
Data Link (DL) Layer	Reception of MDS CMD	S(0)+ID response	–
	Reception of CDRW CMD	ACK + IN Data response (I/O processing)	–
	CMD error	–	Communications will be possible after returning NOP + Null.
	Lack of statement	–	–

(2) Event Matrix for Intelligent I/Os

	Phase*	P1		P2, P3		P1, P2, P3
	Event	Waits for MDS CMD	Waits for connection	Waits for ID_RD	Sends/Receives I/O data	Communications failed
	Power ON	Initialized state	–	–	–	–
Data Link (DL) Layer	Reception of MDS CMD	Waits for connection after having returned the ID.	–	–	–	–
Application (APL) Layer	Reception of CONNECT	–	Waits for ID_RD	Communications failed	Communications failed	Returns to the original state after having returned an error RES (response).
	Reception of DISCONNECT	–	–	Waits for connection	Waits for connection	–
	Reception of ID_RD	–	–	Sends/Receives I/O data after having sent the ID information such as model.	Sends the ID information such as model.	–
	Reception of Output Data	–	–	–	Returns input data (I/O processing)	–
	Reception of invalid CMD or data	–	–	Communications failed	Communications failed	Returns to the original state after having returned an error RES (response).
	Lack of statement	–	–	–	–	–

* The details of phases are as shown in the table below.

Table D.1 Meanings of Each Phase

Phase	Symbol	Meanings
0	P0	Transits to P1 immediately after the power turns ON.
1	P1	Waits for connection
2	P2	Asynchronous communications possible. Only asynchronous commands can be used.
3	P3	Synchronous communications possible. Asynchronous and synchronous commands can be used.
4	P4	Stops communications. Disconnected state.
5	P5	Power OFF

D.1.3 ID of Intelligent I/O

The ID information when Intelligent I/O and Simple I/O are connected to the Master station is explained below. The ID is read out using a MDS command. Refer to *B.3.1 MDS Command* for details.

- ID Codes

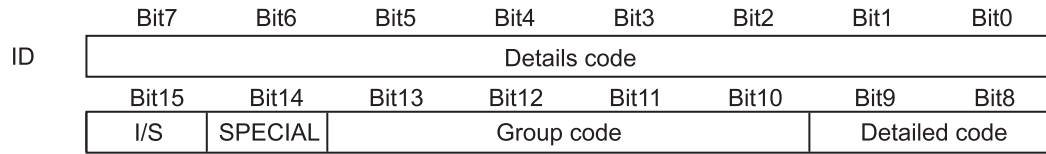

The details of ID code are as shown in the table below.

Table D.2 Meaning of Each Bit

Bit No.	Name	Meanings	
9 to 0	Details code	For future use: 0	
13 to 10	Group code	For future use: 0	
14	SPECIAL	0	Standard
		1	Special
15	I/S	1	Intelligent I/O (Always 1)

Index

Numerics

120AVI02030	3-53
120AVO01030	3-62
120DAI53330	3-14
120DAI73330	3-20
120DAO83330	3-26
120DDI34330	3-40
120DDO34340	3-46
120DRA83030	3-7

64-point I/O Module

DIP switch for setting	4-4
external wiring terminals	4-3
I/O indicator switch	4-3
I/O signal connector	4-3
input signal connector IN2	4-13
MECHATROLINK connector	4-3
output signal connector OUT1	4-14
output signal connector OUT2	4-16
slave address setting	4-4
station number switch	4-3

A

AN2900	3-53
AN2910	3-62
Analog Input Module	
input characteristics	3-57
Analog Output Module	
output characteristics	3-66
automatic disconnection	1-2
automatic restart	1-2

C

circuit configuration	
100/200-VAC 8-point Output Module	3-30
100VAC 8-point Input Module	3-18
200-VAC 8-point Input Module	3-23
24-VDC 16-point Input Module	3-44
24-VDC 16-point Output Module	3-50
24-VDC 8-point I/O Module	3-37
Analog Input Module	3-58
Analog Output Module	3-67
Counter Module	5-20, 5-22
Relay Contact 8-point Output Module	3-11
connection example	
100/200-VAC 8-point Output Module	3-31
100VAC 8-point Input Module	3-18
200-VAC 8-point Input Module	3-24
24-VDC 16-point Input Module	3-44
24-VDC 16-point Output Module	3-51
24-VDC 8-point I/O Module	3-38
Analog Input Module	3-59
Analog Output Module	3-67
IO2310 Module	4-18
Relay Contact 8-point Output Module	3-12
Counter Module	
example of system configuration	5-11
examples of ladder programming	5-54
input registers	5-37
input relays	5-36
interface with the host controller	5-12

ladder program example	5-55
monitoring the current value	5-38
monitoring the current value set value	5-41
monitoring the external latch data	5-38
monitoring the mode setting value	5-39
monitoring the notch points	5-40
monitoring the status	5-39
operation flowchart	5-49
output coils	5-34
output registers	5-35
precautions on wiring	5-42
related reference	5-50
terminal block terminal layout	5-10

D

differential voltage output	5-28
DIP switch settings	
100/200-VAC 8-point Output Module	3-27
100-VAC 8-point Input Module	3-15
200-VAC 8-point Input Module	3-21
24-VDC 16-point Input Module	3-41
24-VDC 16-point Output Module	3-47
24-VDC 8-point I/O Module	3-34
Analog Input Module	3-54
Analog Output Module	3-63
Counter Module	5-7
MP940	7-3
Pulse Output Module	6-5
Relay Contact 8-point Output Module	3-8

E

external appearance and configuration	
100/200-VAC 8-point Output Module	3-26
100-VAC 8-point Input Module	3-14
200-VAC 8-point Input Module	3-20
24-VDC 16-point Input Module	3-40
24-VDC 16-point Output Module	3-46
24-VDC 8-point I/O Module	3-33
64-point I/O Module	4-2
Analog Input Module	3-53
Analog Output Module	3-62
Counter Module	5-6
MP940	7-2
Pulse Output Module	6-4
Relay Contact 8-point Output Module	3-7
external current value reset	
circuit configuration	5-22
connection examples	5-29
specification	5-22
external latch	
circuit configuration	5-22
connection examples	5-29
specification	5-22
external notch output	
circuit configuration	5-23
connection example	5-31
specification	5-23
external view and components	
REP2000	8-3

G

general specifications	
Counter Module	5-13
Distributed I/O Modules	3-3
MP940	7-5
Pulse Output Module	6-10

- REP2000 ----- 8-6
grounding ----- 9-20
grounding power panels ----- 9-21
- ## H
- hardware specifications
Counter Module----- 5-14
MP940 ----- 7-6
Pulse Output Module ----- 6-11
REP2000 ----- 8-7
high-speed pulse counting function ----- 5-2
- ## I
- I/O allocations
100/200-VAC 8-point Output Module ----- 3-32
100-VAC 8-point Input Module ----- 3-19
200-VAC 8-point Input Module ----- 3-25
24-VDC 16-point Input Module ----- 3-45
24-VDC 16-point Output Module----- 3-52
24-VDC 8-point I/O Module ----- 3-39
Analog Input Module ----- 3-61
Analog Output Module ----- 3-68
Counter Module----- 5-32
Pulse Output Module ----- 6-20
Relay Contact 8-point Output Module ----- 3-13
I/O map ----- 2-11
I/O register configuration ----- 2-13
I/O register number ----- 2-4
IO2310 ----- 4-2
IO2900 ----- 3-40
IO2910 ----- 3-46
IO2950 ----- 3-7
IO350 ----- 4-2
- ## L
- latch mode ----- 5-4
leading and end I/O register numbers setting ----- 2-4
- ## M
- master devices ----- 1-5
master module definitions ----- 2-2
maximum number of connectable slaves ----- 1-5
MECHATROLINK
compatible devices ----- 1-5
transmission specifications ----- 1-2
transmission status ----- 2-12
MECHATROLINK cables
appearance ----- 9-7
internal cable connections ----- 9-8
MP2000 series----- 9-6
MP900 series----- 9-5
MECHATROLINK connectors
connection method ----- 9-4
connector specifications ----- 9-3
connector types ----- 9-2
internal connections ----- 9-3
master station ----- 9-4
slave station ----- 9-4
MECHATROLINK definitions window----- 2-6
module configuration
MP2000 series----- 2-3
MP900 series----- 2-2
motion control function specifications
MP940 ----- 7-8
mounting directions
Distributed I/O Module----- 3-5
MP910 connection example ----- 9-10
MP920 (SVB-01) connection example ----- 9-11
MP930 connection example ----- 9-14
MP940 connection example ----- 9-15
- ## N
- notch signal output function ----- 5-3
- ## O
- open-collector output (12-VDC connection)----- 5-26
open-collector output (24-VDC connection)----- 5-25
- ## P
- PC panel isolation ----- 9-22
performance specifications
100/200-VAC 8-point Output Module ----- 3-29
100-VAC 8-point Input Module ----- 3-17
200-VAC 8-point Input Module ----- 3-23
24-VDC 16-point Input Module----- 3-43
24-VDC 16-point Output Module----- 3-49
24-VDC 8-point I/O Module ----- 3-35
Analog Input Module ----- 3-56
Analog Output Module----- 3-65
Counter Module ----- 5-15
IO350 I/O Module ----- 4-6
Pulse Output Module ----- 6-11
Relay Contact 8-point Output Module----- 3-10
phase-A pulse
circuit configuration----- 5-20
connection examples ----- 5-25
external input signal specifications ----- 5-19
phase-B pulse
circuit configuration----- 5-20
connection examples ----- 5-25
external input signal specifications ----- 5-19
Pulse Output Module
circuit configuration----- 6-15
connection example ----- 6-18
connection example with stepping motor driver ----- 6-19
example of system configuration ----- 6-8
external appearance and configuration ----- 6-4
external input signal specifications ----- 6-14
external output signal specifications ----- 6-13
input registers ----- 6-26
input relays----- 6-25
interface with the host controller ----- 6-9
JOG operation function ----- 6-2, 6-37
monitor function ----- 6-3
monitoring parameters ----- 6-28
monitoring the alarm ----- 6-27
monitoring the current position ----- 6-27
output coils----- 6-22
output registers ----- 6-24
parameter setting function----- 6-3
parameters ----- 6-23
positioning function----- 6-2, 6-32
terminal block terminal layout ----- 6-7
zero point return function ----- 6-3, 6-40
pulse output operation example ----- 6-12
pulse output timing ----- 6-12
pulse timing and counting ----- 5-17
pulse waveform----- 5-18

R

REP2000	
connectors	8-3
DIP switch	8-4
LED indicators	8-3
mounting orientation	8-9
restrictions	8-8
system configuration example	8-5
repeater for MECHATROLINK-II (REP2000)	8-2

S

side-by-side mounting	9-21
slave address settings	
100/200 VAC 8-point Output Module	3-28
100-VAC 8-point Input Module	3-16
200-VAC 8-point Input Module	3-22
24-VDC 16-point Input Module	3-42
24-VDC 16-point Output Module	3-48
24-VDC 8-point I/O Module	3-34
Analog Input Module	3-55
Analog Output Module	3-64
Relay Contact 8-point Output Module	3-9
slave devices	1-5
sourcing-voltage output (5-VDC connection)	5-27
special state mode	5-5
state mode	5-3
status	2-12

T

terminator (terminating resistor)	1-4
transmission parameters setting	
MP2000 series	2-8
MP900 series	2-7

W

wildcard I/O Modules	4-19
wiring between panels	
indoors	9-18
outdoor	9-19

Revision History

The date of publication, revision number, and web revision number are given at the bottom right of the back cover. Refer to the following example.

MANUAL NO. SIE-C887-5.1D <7>-1
 Published in Japan February 2008

Web revision number
 Revision number
 Date of publication

Date of Publication	Rev. No.	Web Rev. No.	Section	Revised Contents
January 2023	<14>	6	4.1.3	Partly revised.
			Back cover	Revision: Address
October 2020		5	3.10.4, 3.10.5	Revision: Circuit Configuration
August 2020		4	4.1.3 (5)(a), 4.1.3 (5)(b)	Revision: Connection Examples
			Back cover	Revision: Address
June 2018		3	2.1.3	Revision: Output register size for distributed I/O module
			3.2.2, 3.9.2, 3.10.2, 5.4.2, 6.4.2	Revision: Maximum Heating Value
			3.6.2, 5.4.2	Revision: External Power Supply
			Back cover	Revision: Address
February 2016		2	Front cover	Revision: Format
			1.2.1 (2)	Revision: Information on the following models: JAMSC-IO2950-E, JAMSC-IO2900-E, JAMSC-IO2910-E, JEPMC-IO2310, and JEPMC-IO2330.
			3.6.2	Revision: Maximum heating value
			Back cover	Revision: Address and format
July 2014		1	4.2	Revision: Information on the number of words that can be set : 8 bits → 16 bits
March 2014	0	–	SIE-C887-5.1G<13>-2, available on the Web.	
		Back cover	Revision: Address	
January 2013	<13>	2	1.2.1(2)	Deletion: Information about the following models JAPMC-IO2900-E, JAPMC-IO2910-E, JAPMC-IO2950-E Addition: Information about the following models JAMSC-IO2900-E, JAMSC-IO2910-E, JAMSC-IO2950-E
			2.1.3, 3.7.2, 3.8.2, A.1.2, A.1.7, A.1.8, B.1.2	Revision: Model numbers JAPMC-IO2900-E → JAMSC-IO2900-E JAPMC-IO2910-E → JAMSC-IO2910-E JAPMC-IO2950-E → JAMSC-IO2950-E
			Back cover	Revision: Address
December 2012	1	3.9.2, 3.10.2, 5.4.2	Revision: Specifications of external power supply	
			6.4.2 (1)	Revision: Specification of internal current consumption
			6.4.2 (5)	Revision: Specifications of output voltage drop of CW and CCW pulse outputs and general-purpose outputs
			6.4.2 (6)	Revision: Specifications of standard operating range and input delay times of zero point signal
		Back cover	Revision: Address	
July 2012	0	–	Printed version of the user's manual that is available on the web (web version: SIE-C887-5.1F<12>-2)	
April 2012	<12>	2	9.1.1 (3)	Revision: Connector Model
			Back cover	Revision: Address
March 2011	1	4.1.3 (5)	Revision: Diagram	
November 2010	0	–	Based on Japanese user's manual, SI-C887-5.1G<16>-1 published in July 2010.	
		Front cover	Revision: Format	
		Back cover	Revision: Address, format	
August 2010	<11>	0	–	SIE-C887-5.1E<10>-1, available on the Web.
		Back cover	Revision: Address	
September 2009	<10>	1	Preface	Addition: Warranty
			Back cover	Revision: Address
September 2008	0	Chapter 3	Addition: Description of 24-VDC 16-point Input Module IO2900 and 24-VDC 16-point Output Module IO2910	

Date of Publication	Rev. No.	Web Rev. No.	Section	Revised Contents
August 2008	<9>	0	Preface	Addition: PL on fumigation
			6.6.3	Revision: Setting range of positioning acceleration/deceleration time
			Back cover	Revision: Address
April 2008	<8>	0	–	Published version of the user's manual, SI-C887-5.1D<7>-1, available on the Web.
February 2008	<7>	1	4.1.2(2)(b)	Revision: Output Circuit
			4.1.3	Addition: Standard Cable Wire Table
				Revision: Output Signal Connector OUT1: Typical Connection of the IO2330 Output Signal Connector OUT2: Typical Connection of IO350 and IO2310
			5.5.6	Revision: Description of "ACK", "ERR"
			6.6.3	Addition: Note about setting range of positioning speed (Parameter 05)
			Back cover	Revision: Address
October 2005		0	–	Based on Japanese user's manual, SI-C887-5.1E<7>-1, available on the Web.
May 2005	<6>	–	–	Based on Japanese user's manual, SI-C887-5.1E<6> printed in May 2005.
			All chapters	Addition: I/O Module model: JEPMC-IO2330
			3.1.3	Deletion: DIP switch settings
			3.2 to 3.9	Addition: DIP switch settings used for each module
			Chapter 4	Completely revised
September 2004	<5>	–	–	Based on Japanese user's manual, SI-C887-5.1D<4> printed in February 2004.
			Chapter 8	Addition: MECHATROLINK-II Repeater
			Appendix B	Addition: MECHATROLINK Simple I/O Communications Commands
			Appendix C	Addition: MECHATROLINK Intelligent I/O Communications Commands
			Appendix D	Addition: Supplemental Information
May 2004	<4>	–	Chapters 4 and 8	Slightly revised
			Back cover	Revision: Address
November 2003	<3>	–	–	Based on Japanese user's manual, SI-C887-5.1C<3> printed in May 2003.
			All sections	Addition: Description of MP2000 series Machine Controller Distributed Analog I/O Module JEPMC-AN2900/AN2910 Revision: MECHATROLINK was classified into MECHATROLINK-I and MECHATROLINK-II. Driver Module was changed to Master Module.
			Chapter 1	Completely revised
			1.2.1	Addition: Section of MECHATROLINK-compatible devices
			1.2.2	Addition: Section of maximum number of connectable slaves
			1.2.3	Addition: Description of system configuration precautions
			Chapter 2	Deleted
			Chapter 2 (Chapter 3 before deletion above)	Completely revised
			3.1.3	Addition: Description of DIP switches used for Analog I/O Module
			Chapter 4	Deleted
			5.5.2	Addition: Section of connection examples of external I/O terminals
			5.6.1	Addition: Section of external pulse input circuit
			5.6.2	Addition: Section of external input circuit
			5.6.3	Addition: Section of external output circuit
			6.4.2 (7)	Addition: Circuits for external I/O signals
			6.5.1	Addition: Connection example of general-purpose I/O and zero-point input
			Back cover	Revision: Address
July 2003	<2>	–	Back cover	Revision: Address
February 2003	<1>	–	Preface	Revision: Related manuals
September 2000	–	–	–	First edition: Based on Japanese user's manual, SI-C887-5.1 printed in February 2000.

Machine Controller MP900/MP2000 Series

Distributed I/O Module

USER'S MANUAL

MECHATROLINK System

IRUMA BUSINESS CENTER (SOLUTION CENTER)

480, Kamifujisawa, Iruma, Saitama, 358-8555, Japan
Phone: +81-4-2962-5151 Fax: +81-4-2962-6138
www.yaskawa.co.jp

YASKAWA AMERICA, INC.

2121, Norman Drive South, Waukegan, IL 60085, U.S.A.
Phone: +1-800-YASKAWA (927-5292) or +1-847-887-7000 Fax: +1-847-887-7310
www.yaskawa.com

YASKAWA ELÉTRICO DO BRASIL LTDA.

777, Avenida Piraporinha, Diadema, São Paulo, 09950-000, Brasil
Phone: +55-11-3585-1100 Fax: +55-11-3585-1187
www.yaskawa.com.br

YASKAWA EUROPE GmbH

Hauptstraße 185, 65760 Eschborn, Germany
Phone: +49-6196-569-300 Fax: +49-6196-569-398
www.yaskawa.eu.com E-mail: info@yaskawa.eu.com

YASKAWA ELECTRIC KOREA CORPORATION

18F, Hi Investment & Securities Building, 66 Yeoui-daero, Yeongdeungpo-gu, Seoul, 07325, Korea
Phone: +82-2-784-7844 Fax: +82-2-784-8495
www.yaskawa.co.kr

YASKAWA ASIA PACIFIC PTE. LTD.

30A, Kallang Place, #06-01, 339213, Singapore
Phone: +65-6282-3003 Fax: +65-6289-3003
www.yaskawa.com.sg

YASKAWA ELECTRIC (THAILAND) CO., LTD.

59, 1F-5F, Flourish Building, Soi Ratchadapisek 18, Ratchadapisek Road, Huaykwang, Bangkok, 10310, Thailand
Phone: +66-2-017-0099 Fax: +66-2-017-0799
www.yaskawa.co.th

YASKAWA ELECTRIC (CHINA) CO., LTD.

22F, Link Square 1, No.222, Hubin Road, Shanghai, 200021, China
Phone: +86-21-5385-2200 Fax: +86-21-5385-3299
www.yaskawa.com.cn

YASKAWA ELECTRIC (CHINA) CO., LTD. BEIJING OFFICE

Room 1011, Tower W3 Oriental Plaza, No.1, East Chang An Avenue,
Dong Cheng District, Beijing, 100738, China
Phone: +86-10-8518-4086 Fax: +86-10-8518-4082

YASKAWA ELECTRIC TAIWAN CORPORATION

12F, No. 207, Section 3, Beishin Road, Shindian District, New Taipei City 23143, Taiwan
Phone: +886-2-8913-1333 Fax: +886-2-8913-1513 or +886-2-8913-1519
www.yaskawa.com.tw

YASKAWA

YASKAWA ELECTRIC CORPORATION

In the event that the end user of this product is to be the military and said product is to be employed in any weapons systems or the manufacture thereof, the export will fall under the relevant regulations as stipulated in the Foreign Exchange and Foreign Trade Regulations. Therefore, be sure to follow all procedures and submit all relevant documentation according to any and all rules, regulations and laws that may apply. Specifications are subject to change without notice for ongoing product modifications and improvements.

© 2000 YASKAWA ELECTRIC CORPORATION

MANUAL NO. SIE-C887-5.1H <14>-6

Published in Japan January 2023

22-4-18

Original instructions