

Σ Series SGM□/SGDB-□□AM USER'S MANUAL

AC Servodrives

SGMG/SGMS/SDMD/SGMP/SGM Servomotors

SGDB-□□AM Servopack





YASKAWA

MANUAL NO. SIE-S800-16.3B



Safety Information

The following conventions are used to indicate precautions in this manual. Failure to heed precautions provided in this manual can result in serious or possibly even fatal injury or damage to the products or to related equipment and systems.

 **WARNING** Indicates precautions that, if not heeded, could possibly result in loss of life or serious injury.

 **Caution** Indicates precautions that, if not heeded, could result in relatively serious or minor injury, damage to the product, or faulty operation.

The warning symbols for ISO and JIS standards are different, as shown below.

ISO	JIS
	

The ISO symbol is used in this manual.

Both of these symbols appear on warning labels on Yaskawa products. Please abide by these warning labels regardless of which symbol is used.

©Yaskawa, 1999

All rights reserved. No part of this publication may be reproduced, stored in a retrieval system, or transmitted, in any form, or by any means, mechanical, electronic, photocopying, recording, or otherwise, without the prior written permission of Yaskawa. No patent liability is assumed with respect to the use of the information contained herein. Moreover, because Yaskawa is constantly striving to improve its high-quality products, the information contained in this manual is subject to change without notice. Every precaution has been taken in the preparation of this manual. Nevertheless, Yaskawa assumes no responsibility for errors or omissions. Neither is any liability assumed for damages resulting from the use of the information contained in this publication.

Visual Aids

The following aids are used to indicate certain types of information for easier reference.



Indicates application examples.



Indicates supplemental information.



Indicates important information that should be memorized.



Describes technical terms that are difficult to understand, or appear in the text without an explanation being given.



JUSP-OP02A-1

The text indicated by this icon explains the operating procedure using the Hand-held Digital Operator (JUSP-OP02A-1).

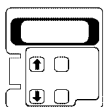

JUSP-OP03A

The text indicated by this icon explains the operating procedure using a Mounted Digital Operator (JUSP-OP03A).

OVERVIEW

1 For First-time Users of AC Servos	1 - 1
2 Basic Use	2 - 1
3 Advanced Use	3 - 1
4 Using Serial Communications	4 - 1
5 Using the Digital Operator	5 - 1
6 Servo Selection and Data Sheets	6 - 1
7 Inspection, Maintenance, and Troubleshooting ..	7 - 1

A Servo Adjustment	A - 1
B List of I/O Signals	B - 1
C List of Parameters	C - 1
D List of Alarm Displays	D - 1
E Supplementary Information on SGDB-□□AMA SERVOPACKs (Contact I/O with Reverse Common)	E - 1

TABLE OF CONTENTS

Safety Information	iii
Visual Aids	iv
Overview	xxx
Using This Manual	xxxii
Safety Precautions	xxxii
1 For First-time Users of AC Servos	
1.1 Basic Understanding of AC Servos	1 -2
1.1.1 Servo Mechanisms	1 -2
1.1.2 Definition of Technical Terms	1-4
1.2 Servo Configuration	1 -5
1.2.1 Configuration of Servo System	1 -5
1.3 Features of Σ-Series Servos	1 -10
1.3.1 Outline of the Σ -Series Servos	1 -10
1.3.2 Software Upgrading	1 -11
1.3.3 Using the SGDB SERVOPACK	1 -11
2 Basic Use	
2.1 Precautions	2 -2
2.2 Installation	2 -4
2.2.1 Checking on Delivery	2 -4
2.2.2 Installing a Servomotor	2 -7
2.2.3 Installing a SERVOPACK	2 -10
2.2.4 Power Losses	2 -12
2.3 Connection and Wiring	2 -13
2.3.1 Connecting to Peripheral Devices	2 -13
2.3.2 Main Circuit Wiring and Power ON Sequence	2 -20
2.4 Conducting a Test Run	2 -23
2.4.1 Test Run in Two Steps	2 -23
2.4.2 Step 1: Conducting a Test Run for Motor without Load	2 -24
2.4.3 Step 2: Conducting a Test Run with the Motor Connected to the Machine	2 -28
2.4.4 Supplementary Information on Test Run	2 -29
3 Advanced Use	
Before Reading this Chapter	3 -4
3.1 Setting Up the Σ SERVOPACK	3 -5
3.1.1 Setting the Motor Model	3 -5
3.1.2 Setting the Number of Encoder Pulses	3 -6

3.1.3	Direction of Motor Rotation	3 -7
3.1.4	Parameter Settings for Machine System	3 -8
3.1.5	Electronic Gear	3 -9
3.1.6	Setting the Acceleration/Deceleration Type and Rate	3 -12
3.1.7	Setting Speed Limits	3 -16
3.1.8	Setting Torque Limits	3 -16
3.1.9	Setting Stored Stroke Limits	3 -19
3.1.10	Setting Backlash Compensation	3 -20
3.2	Signals Common to All Modes	3 -21
3.2.1	Servo ON Signal	3 -21
3.2.2	Pause Inputs	3 -22
3.2.3	Overtravel Limit Function	3 -25
3.2.4	Operation Mode Selection	3 -29
3.2.5	Operation Mode Display Output	3 -30
3.2.6	Operation Start Input	3 -31
3.2.7	Reset and Alarm Reset Input	3 -33
3.2.8	Servo Alarm Output	3 -34
3.2.9	Command Error Outputs	3 -35
3.2.10	Alarm Code Outputs	3 -37
3.2.11	Positioning Complete and Positioning Proximity Signals	3 -39
3.2.12	Servo Ready Output Signal	3 -42
3.2.13	Running Detection Signal	3 -43
3.2.14	OL Warning and Alarm Output Signals	3 -45
3.2.15	Analog Monitor Signals	3 -46
3.3	Feed Speed Setting in Automatic and Manual Operation Modes	3 -48
3.4	Automatic Mode: Station Numbers	3 -50
3.4.1	Position Command Input Signals	3 -52
3.4.2	Rotating Direction Select Input	3 -53
3.4.3	Current Station Number Output and Station Number Read Selection Input ...	3 -54
3.4.4	Station Proximity Signal	3 -56
3.4.5	Manual Operation Mode	3 -57
3.4.6	Inputting Speed Command Data	3 -57
3.5	Automatic Mode: Digital Switches	3 -60
3.5.1	Position Command Input Signals, Speed Command Input Signals, and Strobe Output Signals	3 -62
3.5.2	Speed Command	3 -66
3.5.3	Digital Switch Unit	3 -67
3.5.4	Contact Input Unit	3 -68
3.6	Automatic Mode: Serial Communications	3 -70
3.6.1	Serial Commands	3 -72
3.7	Automatic Mode: Command Table	3 -88
3.7.1	Data Number Input Signals	3 -90
3.7.2	Zone Signal Outputs	3 -91
3.7.3	Speed Command Input	3 -94
3.8	Manual Mode	3 -95

3.9 Pulse Operation Mode	3 -96
3.10 Machine Zero Point Return Mode	3 -100
3.10.1 Machine Zero Point Return Mode I (Bits 2 and 3 of Cn-29 Set to 0)	3 -101
3.10.2 Machine Zero Point Return Mode II (Bits 2 and 3 of Cn-29 Set to 1 and 0 Respectively)	3 -102
3.10.3 Machine Zero Point Return Mode III (Bits 2 and 3 of Cn-29 Set to 1)	3 -102
3.11 Encoder Outputs	3 -104
3.12 External Pulse Generators	3 -107
3.13 External Position Indicator	3 -109
3.14 Setting the Stop Function	3 -111
3.14.1 Dynamic Brake	3 -111
3.14.2 Holding Brake	3 -112
3.15 Smooth Operation	3 -115
3.15.1 Adjusting Gain	3 -115
3.15.2 Setting the Torque Command Filter Time Constant	3 -116
3.16 Minimizing Positioning Time	3 -118
3.16.1 Autotuning Function	3 -118
3.16.2 Servo Gain Switching	3 -118
3.16.3 Feed-forward Control	3 -119
3.16.4 Speed Bias	3 -119
3.16.5 Proportional Control	3 -120
3.16.6 Mode Switch	3 -120
3.17 Handling Power Loss	3 -124
3.18 Special Wiring	3 -125
3.18.1 Wiring Instructions	3 -125
3.18.2 Wiring for Noise Control	3 -126
3.18.3 Using More Than One Servodrive	3 -131
3.18.4 Using Regenerative Resistor Units	3 -132
3.18.5 Using an Absolute Encoder	3 -134
3.18.6 Extending an Encoder Cable	3 -137
3.18.7 Using SGDB SERVOPACK with High Voltage Lines	3 -140
3.18.8 Connector Terminal Layouts	3 -141
4 Using Serial Communications	
4.1 Connecting and Setting Up Serial Communications	4 -2
4.1.1 Overview	4 -2
4.1.2 Wiring to the Host Controller	4 -3
4.1.3 Baud Rate and Command Length Mode Settings	4 -6
4.1.4 Axis Address Settings	4 -8
4.1.5 Axis Number Setting	4 -9
4.1.6 Group Function Setting	4 -9

4.2 Serial Communications Commands	4 -10
4.2.1 Sending Commands to a SERVOPACK	4 -10
4.2.2 Reading Data from a SERVOPACK	4 -12
4.3 Using Fixed Length Mode	4 -17
4.3.1 Calculating the Checksum	4 -17
4.3.2 Handling Communications Errors	4 -17
4.3.3 Data Sent from the SERVOPACK	4 -18
4.4 Serial Commands for Settings and Monitoring	4 -21
4.4.1 List of Commands	4 -21
4.4.2 Command Details	4 -24
4.5 Communications Specifications	4 -32
4.5.1 Hardware Specifications	4 -32
4.5.2 Communications Control Codes	4 -33
4.5.3 Transmission/Reception Timing	4 -33
5 Using the Digital Operator	
5.1 Basic Operation	5 -2
5.1.1 Connecting the Digital Operator	5 -2
5.1.2 Precaution If Connecting/Disconnecting the Digital Operator	5 -2
5.1.3 Digital Operator Functions	5 -3
5.1.4 Resetting Servo Alarms	5 -4
5.1.5 Basic Functions and Mode Selection	5 -5
5.1.6 Status Display Mode	5 -6
5.1.7 Parameter Setting Mode	5 -8
5.1.8 Position Table Setting Mode	5 -12
5.1.9 Speed Table Setting Mode	5 -14
5.1.10 Boundary Table Setting Mode	5 -15
5.1.11 Monitor Mode	5 -17
5.2 Practical Operation	5 -24
5.2.1 Operation in Alarm Trace-back Mode	5 -24
5.2.2 Operation Using the Digital Operator	5 -24
5.2.3 Autotuning	5 -30
5.2.4 Clearing Alarm Trace-back Data	5 -36
5.2.5 Checking the SERVOPACK Specifications	5 -38
5.2.6 Checking the Software Version	5 -39
5.2.7 Adjusting the Current Detection Offset Manually	5 -40
5.2.8 Setting the Machine Zero Point	5 -42
5.2.9 Saving Backup Data	5 -45
5.2.10 Reading Backup Data	5 -47
5.2.11 Initializing Backup Data	5 -49

6 Servo Selection and Data Sheets

6.1 Selecting a Σ-Series Servo	6 -3
6.1.1 Selecting a Servomotor	6 -3
6.1.2 Selecting a SERVOPACK	6 -15
6.1.3 Selecting a Digital Operator	6 -17
6.2 Servomotor Ratings and Specifications	6 -19
6.2.1 Ratings and Specifications	6 -19
6.2.2 Mechanical Characteristics	6 -41
6.3 SERVOPACK Ratings and Specifications	6 -45
6.3.1 Combined Specifications	6 -45
6.3.2 Ratings and Specifications	6 -48
6.3.3 Overload Characteristics	6 -52
6.3.4 Starting Time and Stopping Time	6 -53
6.3.5 Load Inertia	6 -53
6.3.6 Overhanging Loads	6 -54
6.4 Σ-Series Dimensional Drawings	6 -55
6.4.1 Servomotor Dimensional Drawings	6 -55
6.4.2 SERVOPACK Dimensional Drawings	6 -138
6.4.3 Digital Operator Dimensional Drawings	6 -149
6.5 Selecting Peripheral Devices	6 -150
6.5.1 Selecting Peripheral Devices	6 -150
6.5.2 Order List	6 -165
6.6 Specifications and Dimensional Drawings of Peripheral Devices	6 -190
6.6.1 Cable Specifications and Peripheral Devices	6 -190
6.6.2 Motor Cables	6 -194
6.6.3 Connector	6 -195
6.6.4 Brake Power Supply	6 -216
6.6.5 Encoder Cables	6 -218
6.6.6 Back-up Battery	6 -229
6.6.7 1CN and 6CN Connectors	6 -230
6.6.8 3CN Connector	6 -232
6.6.9 Connector-Terminal Block Conversion Unit	6 -233
6.6.10 Cable with 1CN Connector and One End without Connector	6 -239
6.6.11 Cable with 6CN Connector and One End without Connector	6 -240
6.6.12 Circuit Breaker	6 -241
6.6.13 Noise Filter	6 -241
6.6.14 Magnetic Contactor	6 -243
6.6.15 Surge Suppressor	6 -245
6.6.16 Regenerative Resistor Unit	6 -246
6.6.17 External Position Indicator (Model MCIF-L8)	6 -247
6.6.18 Digital Switch Unit (MCIF-D□□)	6 -249
6.6.19 Contact Input Unit (MCIF-R86)	6 -252
6.6.20 Manual Pulse Generator (PRET-2C3T/100-M1)	6 -255
6.6.21 Cables for Connecting Personal Computer and SERVOPACK	6 -256

7	Inspection, Maintenance, and Troubleshooting	
7.1	Inspection and Maintenance	7 -2
7.1.1	Servomotor	7 -2
7.1.2	SERVOPACK	7 -3
7.1.3	Replacing Battery for Back-up	7 -4
7.2	Troubleshooting	7 -5
7.2.1	Troubleshooting Problems with Alarm Display	7 -5
7.2.2	Troubleshooting Problems with No Alarm Display	7 -34
7.2.3	Internal Connection Diagram and Instrument Connection Examples	7 -36
A	Servo Adjustment	
A.1	Σ-Series AC SERVOPACK Gain Adjustment	A -2
A.1.1	Σ -Series AC SERVOPACKs and Gain Adjustment Methods	A -2
A.1.2	Basic Rules for Gain Adjustment	A -2
A.2	Adjusting a Position-control SERVOPACK	A -4
A.2.1	Adjusting Using Auto-tuning	A -4
A.2.2	Adjusting Manually	A -5
A.3	Gain Setting References	A -8
A.3.1	Guidelines for Gain Settings According to Load Inertia Ratio	A -8
B	List of I/O Signals	
C	List of Parameters	
D	List of Alarm Displays	
E	Supplementary Information on SGDB-□□AMA SERVOPACKs (Contact I/O with Reverse Common)	
E.1	List of I/O Signals	E -3
E.2	Lists of 6CN I/O Signals by Command Mode	E -5
E.3	Contact I/O Circuits	E -12
E.4	Wiring Examples	E -14
	INDEX	Index-1

Overview

■ Manual Contents

This manual provides Σ -Series users with information on the following:

- An overview of servo systems for first-time users.
- Checking the product on delivery and basic use of the servo.
- Advanced use of servo functions.
- Selecting an appropriate Servo for your needs and placing an order.
- Inspection and maintenance.

Using This Manual

■ Basic Terms

Unless otherwise specified, the following definitions are used:

- Servomotor = Σ -Series SGMG, SGMD, SGMS, SGM, or SGMP Servomotor
- SERVOPACK = Σ -Series SGDB-□□AM SERVOPACK (a trademark for Yaskawa servo amplifiers)
- Servodrive = A Servomotor and an amplifier (SGDB-□□AM SERVOPACK)
- Servo system = A complete servo control system consisting of servodrive, host controller, and peripheral devices

■ Explanation of Technical Terms

Technical terms placed in bold in the text are briefly explained in a “TERMS” section at the bottom of the page. The following kinds of technical terms are explained:



◆ Technical Terms Explained in This Manual

Technical terms that need to be explained to users who are not very familiar with servo systems or electronic devices and technical terms specific to Σ Series Servos that need to be explained in descriptions of functions.

Safety Precautions

Please read the following precautions on delivery checking, installation, wiring, operation, and inspection and maintenance.

■ Receiving



Caution

- Use the specified combination of servomotor and SERVOPACK.
Failure to observe this caution may lead to fire or failure.

■ Installation



Caution

- Never use the equipment where it may be exposed to splashes of water, corrosive or flammable gases, or near flammable materials.
Failure to observe this caution may lead to electric shock or fire.

■ Wiring





WARNING

- Ground the equipment ground terminal  according to electrical codes (ground resistance: 100 Ω or less).
Failure to observe this warning may lead to electric shock or fire.



Caution

- Do not connect three-phase power supply to output terminals   and .
Failure to observe this caution may lead to personal injury or fire.
- Securely tighten screws on the power supply and motor output terminals.
Failure to observe this caution can result in a fire.

■ Operation**WARNING**

- Never touch any rotating motor parts during operation.
Failure to observe this warning may result in personal injury.

**Caution**

- To avoid inadvertent accidents, run the servomotor only in test run (without load).
Failure to observe this caution may result in personal injury.
- Before starting operation with a load connected, set up parameters suitable for the machine.
Starting operation without setting up parameters may lead to overrun or failure.
- Before starting operation with a load connected, make sure emergency-stop procedures are in place.
Failure to observe this caution may result in personal injury.
- During operation, do not touch the heat sink.
Failure to observe this caution may result in burns.

■ Inspection and Maintenance**WARNING**

- Never touch the inside of the SERVOPACK.
Failure to observe this warning may result in electric shock.
- Do not remove the panel cover while the power is ON.
Failure to observe this warning may result in electric shock.
- Do not touch terminals for five minutes after the power is turned OFF.
Residual voltage may result in electric shock.

**Caution**

- Do not disassemble the servomotor.
Failure to observe this caution may result in electric shock or personal injury.
- Never change wiring while power is ON.
Failure to observe this caution may result in electric shock or personal injury.

■ General Precautions

Always note the following to ensure safe use.

- Some drawings in this manual are shown with the protective cover or shields removed, in order to describe the detail with more clarity. Make sure all covers and shields are replaced before operating this product.
- Some drawings in this manual are shown as typical example and may differ from the shipped product.
- This manual may be modified when necessary because of improvement of the product, modification or changes in specifications.
Such modification is made as a revision by renewing the manual No.
- To order a copy of this manual, if your copy has been damaged or lost, contact your YASKAWA representative listed on the last page stating the manual No. on the front cover.
- YASKAWA is not responsible for accidents or damages due to any modification of the product made by the user since that will void our guarantee.

For First-time Users of AC Servos

This chapter is intended for first-time users of AC servos. It describes the basic configuration of a servo mechanism and basic technical terms relating to servos.

Users who already have experience in using a servo should also take a look at this chapter to understand the features of Σ -Series AC Servos.

1.1 Basic Understanding of AC Servos	1 -2
1.1.1 Servo Mechanisms	1 -2
1.1.2 Definition of Technical Terms	1 -4
1.2 Servo Configuration	1 -5
1.2.1 Configuration of Servo System	1 -5
1.3 Features of Σ-Series Servos	1 -10
1.3.1 Outline of the Σ -Series Servos	1 -10
1.3.2 Software Upgrading	1 -11
1.3.3 Using the SGDB SERVOPACK	1 -11

1.1 Basic Understanding of AC Servos

This section describes the basic configuration of a servo mechanism and technical terms relating to servos and also explains the features of Σ -Series AC Servos.

1.1.1 Servo Mechanisms

You may be familiar with the following terms:

- Servo
- **Servo mechanism**
- Servo control system

In fact, these terms are synonymous. They have the following meaning:

A control mechanism that monitors physical quantities such as specified positions.

In short, a servo mechanism is like a servant who does tasks faithfully and quickly according to his master's instructions. In fact, "servo" originally derives from the word "servant."

Servo system could be defined in more detail as a mechanism that moves at a specified speed and locates an object in a specified position.



◆ Servo mechanism

According to Japanese Industrial Standard (JIS) terminology, a "servo mechanism" is defined as a mechanism that uses the position, direction, or orientation of an object as a process variable to control a system to follow any changes in a target value (set point).

More simply, a servo mechanism is a control mechanism that monitors physical quantities such as specified positions. Feedback control is normally performed by a servo mechanism. (Source: JIS B0181)

To develop such a servo system, an automatic control system involving **feedback control** must be designed. This automatic control system can be illustrated in the following block diagram:

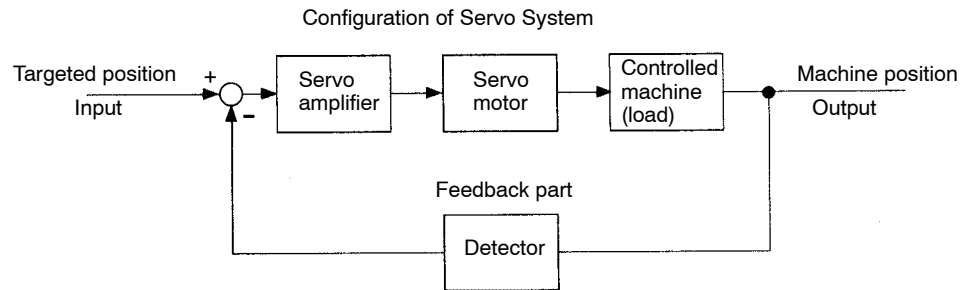

This servo system is an automatic control system that detects the machine position (output data), feeds back the data to the input side, compares it with the specified position (input data), and moves the machine by the difference between the compared data.

In other words, the servo system is a system to control the output data to match the specified input data.

If, for example, the specified position changes, the servo system will reflect the changes.

In the above example, input data is defined as a position, but input data can be any physical quantities such as orientation (angle), water pressure, or voltage.

Position, speed, force (torque), electric current, and so on are typical controlled values for a servo system.



◆ **Feedback control**

A control that returns process variables to the input side and forms a closed loop. It is also called closed-loop control.

1.1.2 Definition of Technical Terms

The main technical terms used in this manual are as follows:

■ Servo

Normally, servo is synonymous with servo mechanism. However, because “mechanism” is omitted, the meaning becomes somewhat ambiguous. Servo may refer to the entire servo mechanism but may also refer to an integral part of a servo mechanism such as a servomotor or a servo amplifier. This manual also follows this convention in the use of the term “servo”.

■ Servo Control System

Servo control system is almost synonymous with servo mechanism but places the focus on system control. In this manual, the term “servo system” is also used as a synonym of servo control system.

Related Terms	Meaning
Servomotor	General servomotors or Yaskawa SGM□ Servomotors. In some cases, a position detector (encoder) is included in a servomotor.
SERVOPACK	Trademark of Yaskawa servo amplifier “SGDB SERVOPACK.”
Servodrive	A Servomotor and amplifier pair. Also called “servo.”
Servo system	A closed control system consisting of a host controller, servodrive and controlled system to form a servo mechanism.

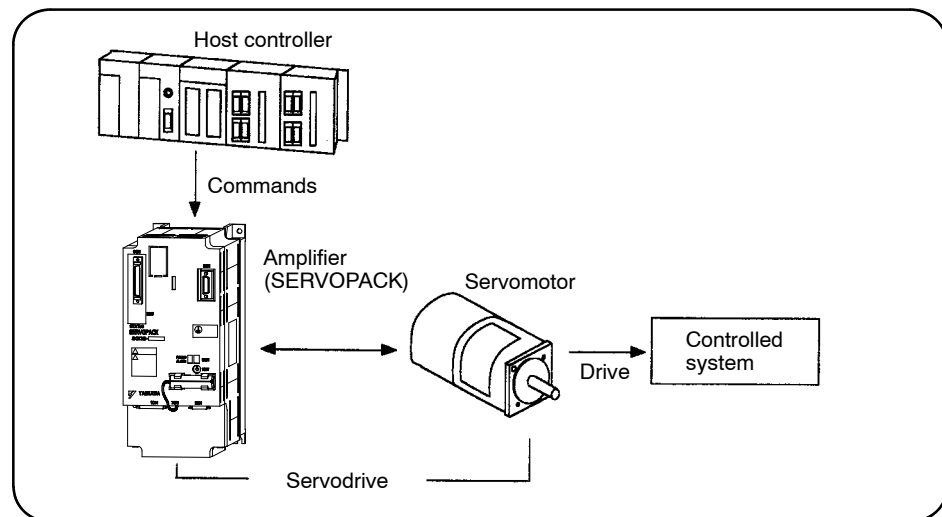

Servo System

1.2 Servo Configuration

This section describes the basic configuration of a servo system.

1.2.1 Configuration of Servo System

The following diagram illustrates a servo system in detail:

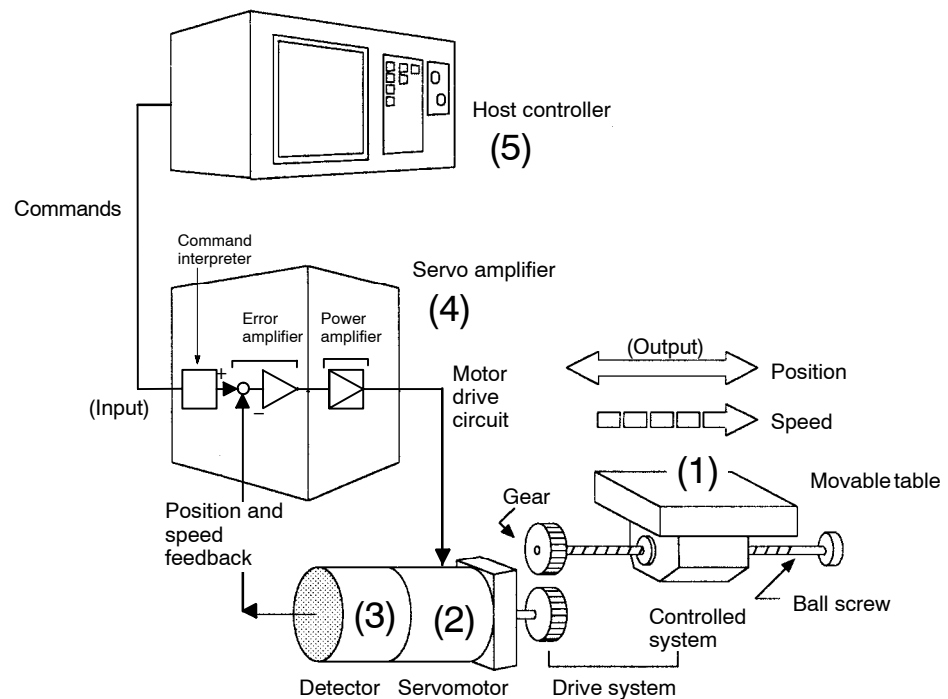

- (1) **Controlled system:** Mechanical system for which the position or speed is to be controlled. This includes a drive system that transmits torque from a servomotor.
- (2) **Servomotor:** A main actuator that moves a controlled system. Two types are available: AC servomotor and DC servomotor.
- (3) **Detector:** A position or speed detector. Normally, an encoder mounted on a motor is used as a position detector.
- (4) **Servo amplifier:** An amplifier that processes an error signal to correct the difference between a command and feedback data, and operates the servomotor accordingly. A servo amplifier consists of a command interpreter, which creates target movement patterns for the servomotor, an error amplifier, which processes error signals, and a power amplifier, which operates the servomotor.
- (5) **Host controller:** A device that controls a servo amplifier by specifying a position or speed as a set point.

Servo components (1) to (5) are outlined below:

■ **Controlled System**

In the previous figure, the controlled system is a movable table for which the position or speed is controlled. The movable table is driven by a ball screw and is connected to the servomotor via gears.

The **drive system** consists of the following parts.

■ **Gears + Ball Screw**

This drive system is most commonly used because the power transmission ratio (gear ratio) can be freely set to ensure high positioning accuracy. However, play in the gears must be minimized.

The following drive system is also possible when the controlled system is a movable table:

■ **Coupling + Ball Screw**

When the power transmission ratio is 1 : 1, a coupling is useful because it has no play.

This drive system is widely used for machining tools.

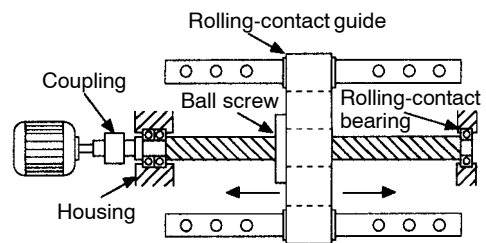

■ **Timing Belt + Trapezoidal Screw**

A timing belt is a coupling device that allows the power transmission ratio to be set freely and that has no play.

A trapezoidal screw thread does not provide excellent positioning accuracy, so can be treated as a minor coupling device.

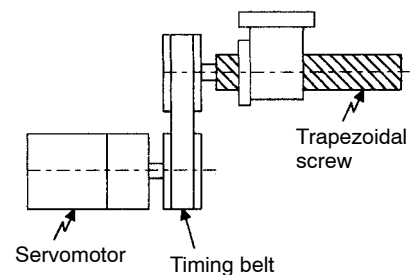

To develop an excellent servo system, it is important to select a rigid drive system that has no play.

Configure the controlled system by using an appropriate drive system for the control purpose.



◆ **Drive system**

Also called a drive mechanism.

A drive system connects an actuator (such as a servomotor) to a controlled system and serves as a mechanical control component that transmits torque to the controlled system, orientates the controlled system, and converts motion from rotation to linear motion and vice versa.

■ Servomotor

DC Servomotor and AC Servomotor

Servomotors are divided into two types: DC servomotors and AC servomotors.

DC servomotors are driven by direct current (DC). They have a long history. Up until the 1980s, the term “servomotor” used to imply a DC servomotor.

From 1984, AC servomotors were emerging as a result of rapid progress in microprocessor technology and other technologies. Driven by alternating current (AC), AC servomotors are now widely used because of the following advantages:

- Easy maintenance: No brush
- High speed: No limitation in rectification rate

Note however that servomotors and SERVOPACKs use some parts that are subject to mechanical wear or aging. For preventive maintenance, inspect and replace parts at regular intervals. For details, refer to *Chapter 7 Inspection, Maintenance, and Troubleshooting*.

AC Servomotor

AC servomotors are divided into two types: synchronous and induction. The synchronous type is more commonly used.

For a synchronous servomotor, motor speed is controlled by changing the frequency of alternating current.

A synchronous servomotor provides strong holding torque when stopped, so this type is ideal when precise positioning is required. Use this type for a servo mechanism for position control.

The following figure illustrates the structure of a synchronous servomotor:

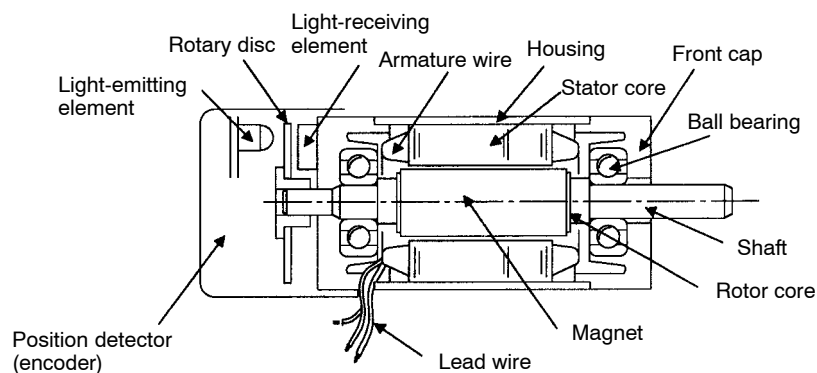

Yaskawa SGM□ Servomotors are of the synchronous type.

Performance of Servomotor

A servomotor must have “instantaneous power” so that it can start as soon as a start command is received. The term “power rating (kW/s)” is used to represent instantaneous power. It refers to the electric power (kW) that a servomotor generates per second. The greater the power rating, the more powerful the servomotor.

■ Detector

A servo system requires a detector to detect the position and speed. There are 2 detection methods: Optical and magnetic. The system uses an optical or magnetic encoder mounted on a servomotor as the detector.

There are two types of encoder: Incremental and absolute.

Incremental Encoder

An incremental encoder is a pulse generator, which generates a certain number of pulses per revolution (e.g., 2,000 pulses per revolution). If this encoder is connected to the mechanical system and one pulse is defined as a certain length (e.g., 0.001 mm), it can be used as a position detector.

However, this encoder does not detect an absolute position and merely outputs a pulse train. Hence zero return operation must be performed before positioning.

The following figure illustrates the operation principle of a pulse generator:

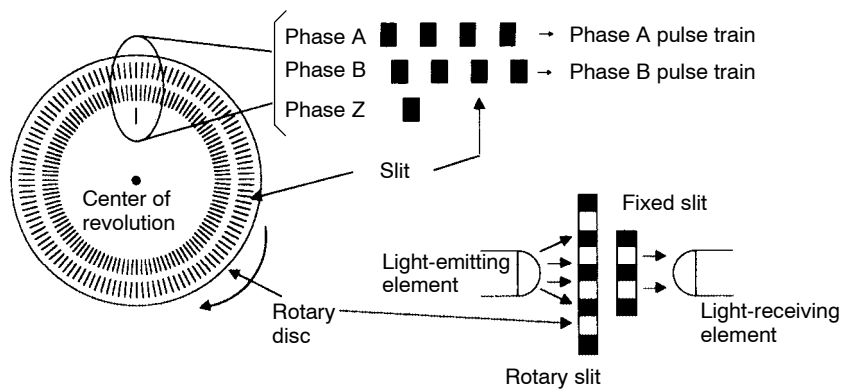

Absolute Encoder

An absolute encoder is designed to detect an absolute angle of rotation as well as to perform the general functions of an incremental encoder. With an absolute encoder, therefore, it is possible to create a system that does not require zero return operation at the beginning of each operation.

Difference between an Absolute and Incremental Encoder

An absolute encoder will keep track of the motor shaft position even if system power is lost and some motion occurs during that period of time. The incremental encoder is incapable of the above.

■ Servo Amplifier

A servo amplifier is required to operate an AC servomotor.

The following figure illustrates the configuration of a servo amplifier:

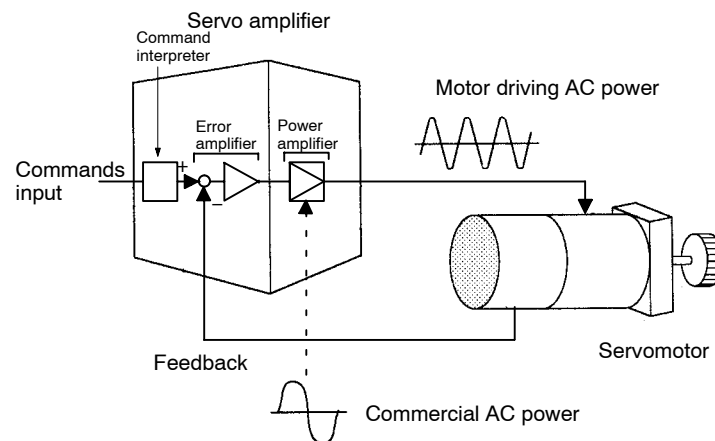

A servo amplifier consists of the following three sections.

Command Interpreter

As shown in the device in the above figure, the command interpreter creates patterns for target movements for the servomotor based on commands sent via serial communications or contact points.

The movement patterns created in the command interpreter are sent to the error amplifier and power amplifier as target signals.

Error amplifier

The error amplifier compares the target signal with a feedback signal and generates a differential signal.

The control function amplifies and transforms the differential signal. In other words, it performs proportional (P) control or **proportional/integral (PI) control**. (It is not important if you do not understand these control terms completely at this point.)

Power Amplifier

A power amplifier runs the servomotor at a speed or torque proportional to the output of the error amplifier. In other words, from the commercial power supply of 50/60 Hz, it generates alternating current with a frequency proportional to the command speed and runs the servomotor with this current.

The Yaskawa SERVOPACK is equivalent to this servo amplifier.

Host Controller

A host controller commands a servo amplifier by specifying a position or speed as a set point.



◆ Proportional/integral (PI) control

PI control provides more accurate position or speed control than proportional control, which is more commonly used.

1.3 Features of Σ -Series Servos

A Σ -Series Servo consists of an SGM Servomotor and an SGDB-AM SERVOPACK (servo amplifier).

1.3.1 Outline of the Σ -Series Servos

This section describes the models of SGM Servomotors and the models of SGDB-AM SERVOPACK controls.

■ Models of SGM Servomotors

The SGM Servomotors are synchronous servomotors and have the following features:

Series	Rated Rotation Speed Maximum Rotation Speed	Rated Output
SGMG	1500 min ⁻¹ 3000 min ⁻¹	0.45 to 15 kW (10 models)
	1000 min ⁻¹ 2000 min ⁻¹	0.3 to 6.0 kW (8 models)
SGMS	3000 min ⁻¹ 4500 min ⁻¹	1.0 to 5.0 kW (6 models)
SGMD	2000 min ⁻¹ 3000 min ⁻¹	2.2 to 4.0 kW (3 models)
SGM	3000 min ⁻¹ 4500 min ⁻¹	0.4 to 0.8 kW (2 models)
SGMP	3000 min ⁻¹ 4500 min ⁻¹	0.4 to 1.5 kW (3 models)

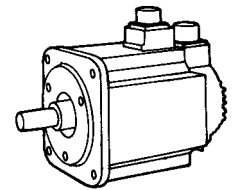

SGMG Servomotor

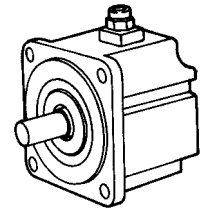

SGMP Servomotor

■ SGDB-□□AM SERVOPACK

The operation of the SGDB-□□AM SERVOPACK is based on commands sent via serial communications or contacts. Information of motor position is managed within the SERVOPACK, and there is no need to form a speed or position feedback loop between the host controller and SERVOPACK. Furthermore, acceleration and deceleration patterns can also be created based on user settings within the SERVOPACK.

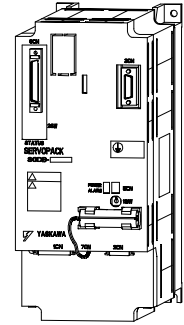

SGDB-□□AM SERVOPACK

1.3.2 Software Upgrading

The following table shows the functions which have been added with the upgrading of the SGDB-□□AM SERVOPACK software. Different versions have different functions, so confirm the version number of the SERVOPACK software before use.

Function	Main CPU Software Version Number
/ERR signal mask when a serial communication error occurs.	0018 and later
Digital-switch scan-time lower limit (12 ms to 24 ms)	0018 and later
Interchangeability of the start signal and the positioning-completed signal	001C and later
Modification of the positioning-completed signal	001C and later
Digital-switch scan-time lower limit (24 ms to 12 ms)	001C and later

■ Confirmation of the Software Version Number

Two types of confirmation methods are available.

With serial communication

The SFT1 command can be used to check the version number of the software being used. For more information, refer to *4.4.2 Command Details*.

With the Digital Operator

The Digital Operator can be used to check the main CPU for the version number of the software being used. For more information, refer to *5.2.6 Checking the Software Version*.

1.3.3 Using the SGDB SERVOPACK

■ Operation Modes

The SGDB-□□AM SERVOPACK has four operation modes. These modes can be switched at any time by means of a contact.

Automatic Mode

Following the input of command position data, the input of an operation start signal performs the positioning based on the input data.

The operation method in automatic mode can be selected from the following: Station numbers, digital switches, serial communications, and command table.

Manual Mode

The Servomotor runs at a constant speed while a manual mode signal is being input.

Pulse Mode

Positioning is performed by a pulse train command from an external pulse generator.

- Pulse system: Line driver, line receiver
- Pulse form: Two-phase pulse trains with 90° phase difference ($\times 1$) (450 kpps max.)
Sign + pulse train (450 kpps max.)
CW + CCW pulse trains (450 kpps max.)

An external PG input is triggered when an /LPG signal is input.

Zero Point Return Mode

This mode is used to perform a zero point return when an incremental encoder is used. The following three modes are available:

1. An STP signal (deceleration limit switch) is used together with the phase-C pulse of the encoder (method 1).
2. Only an STP signal (stop limit switch) is used.
3. An STP signal (deceleration limit switch) is used together with the phase-C pulse of the encoder (method 2).

■ Operation Methods in Automatic Mode

One of the following four operation methods can be selected in automatic mode by setting parameters.

Station Numbers

Performs indexed positioning.

A number attached to an index point (station number) is entered as position data.

Speed data is selected by a speed selection signal from among the four different speeds specified using parameters in the SERVOPACK.

Both one-way rotation and shortest-path rotation can be selected.

A station number can be between 0 and 999 if specified as a decimal number, or between 0 and 4095 if specified as a binary number.

If positioning points are evenly spaced, fewer command signals are needed than in when using digital switches.

Application examples: Disc tables, rotary-type automatic tool changers (ATCs), etc.

Digital Switches

Positioning data is input through digital switches, relays, or PLC contacts.

Positioning data can contain the following:

- Speed data: 6 digits max.
- Position data: Sign + 8 digits max.

This method is suited when the user wants to set positioning to an arbitrary position, and when the user wants to issue a position command without a host controller, such as a PLC or personal computer.

Application examples: Roll feeders, etc.

IMPORTANT

The digital switch method utilizes time-sharing to read data two digits at a time using a strobe signal. It is therefore necessary to use special Yaskawa Digital Switches for this purpose. If other digital switches or relay sare used, be sure to use a Contact Input Unit. Also, when inputting data directly from a PLC, it is necessary to create a ladder program so that the strobe signal scan time (24 to 2,000 μ s, variable) matches the PLC scan time.

Serial Communications

Serial commands are used to enter positioning data (position and speed).

Using multi-drop connections allows a single host controller to send commands to SERVOPACKs for up to 15 axes with a single group configuration or up to 32 axes with a multi-group configuration.

Settings allow the use of a fixed length mode, in which the serial command data length is set to a fixed value.

Serial communications can save the amount of wiring required, particularly in situations where commands are sent to multiple SERVOPACKs.

Application examples: X-Y tables (point-to-point configuration), etc.

Command Table

Positioning data is selected by means of a selection signal from a command table within the SERVOPACK.

Positioning data is selected as a set of position and speed data. Up to 512 sets can be entered.

This method is suited to situations where there are no more than 512 target positions, and these positions are not evenly spaced.

Application examples: Automated warehouses, etc.

2

Basic Use

This chapter describes the first things to do when Σ -Series products are delivered. It also explains the most fundamental ways of connecting and operating Σ -Series products. Both first-time and experienced servo users **must read** this chapter.

2.1	Precautions	2 -2
2.2	Installation	2 -4
2.2.1	Checking on Delivery	2 -4
2.2.2	Installing a Servomotor	2 -7
2.2.3	Installing a SERVOPACK	2 -10
2.2.4	Power Losses	2 -12
2.3	Connection and Wiring	2 -13
2.3.1	Connecting to Peripheral Devices	2 -13
2.3.2	Main Circuit Wiring and Power ON Sequence ...	2 -20
2.4	Conducting a Test Run	2 -23
2.4.1	Test Run in Two Steps	2 -23
2.4.2	Step 1: Conducting a Test Run for Motor without Load	2 -24
2.4.3	Step 2: Conducting a Test Run with the Motor Connected to the Machine	2 -28
2.4.4	Supplementary Information on Test Run	2 -29

2.1 Precautions

This section provides notes on using Σ -Series Servos.

■ Use 200 VAC Power Supply

Be sure to use 200 VAC power supply.

■ Do not plug the Servomotor directly into power outlet.

Do not plug the Servomotor directly into the power outlet. Doing so will damage the Servomotor. The Servomotor cannot be operated without an SGDB SERVOPACK.

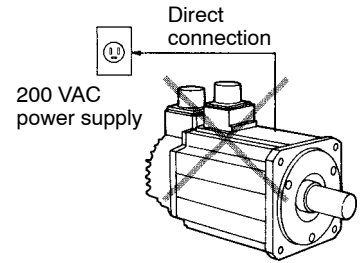

Damage will result!

■ Do not change wiring when power is ON.

Always turn the power OFF before connecting or disconnecting a connector. (Except for Digital Operator (JUSP-OP02A-1, JUSP-OP03A))

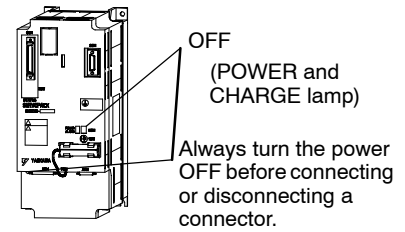

■ Wait 5 minutes or more for inspection after turning OFF the power.

Even after the power is turned OFF, residual electric charge still remains in the capacitor inside the SERVOPACK. To prevent an electric shock, always wait for the CHARGE lamp to go OFF before starting inspection (if necessary).

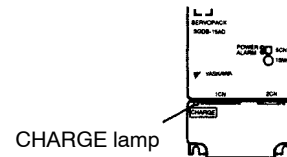

■ Provide at least 10 mm of clearance from other devices.

As shown in the diagram, provide at least 10 mm of clearance from other devices horizontally and at least 50 mm of clearance vertically. The SERVOPACKs generate heat and must be installed to allow sufficient heat dissipation. The SERVOPACKs must also be installed in locations where they will not be affected by condensation, vibration, and shock.

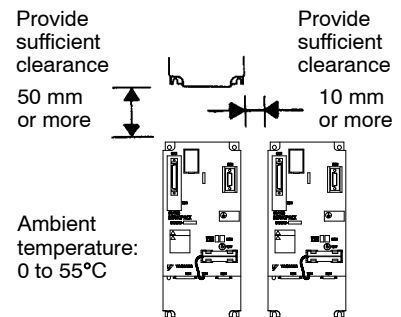

■ **Perform noise reduction and grounding properly.**

If the signal line is noisy, vibration or malfunction will result.

- Separate high-voltage cables from low-voltage cables.
- Use cables as short as possible.
- Use one-line grounding (ground resistance 100 Ω or less) for the Servomotor and SERVOPACK.
- Never use a noise filter for the power supply input between the motor and SERVOPACK.

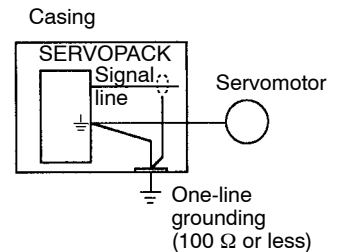

■ **Conduct a voltage resistance test under the following conditions.**

- Voltage: 1500 Vrms AC, one minute
- Interrupting current: 100 mA
- Frequency: 50/60 Hz
- Voltage application points: Between L1C, L3C, L1, L2, L3 terminals and frame ground (connect terminals securely).



Conduct a voltage resistance test under the conditions given on the left.

■ **Use a fast-response ground-fault interrupter.**

For a ground-fault interrupter, always use a fast-response type or one designed for PWM inverters. Do not use a time-delay type.

Ground-fault interrupter		
GOOD	GOOD	POOR
Fast-response type	For PWM inverter	Time-delay type

■ **Do not perform continuous operation under overhanging load.**

Continuous operation cannot be performed by rotating the motor from the load and applying regenerative braking. Regenerative braking by the SERVOPACK can be applied only for a short period, such as the motor deceleration time.

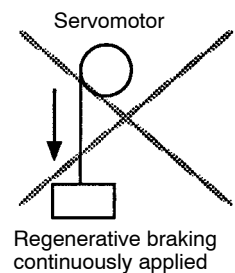

■ **The Servomotor cannot be operated by turning the power ON and OFF.**

Frequently turning the power ON and OFF causes the internal circuit elements to deteriorate. Always start or stop the servomotor by using command signals.

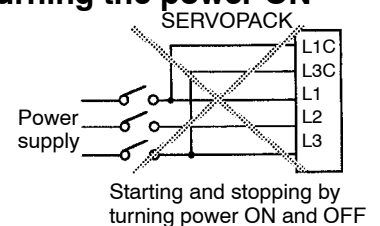

2.2 Installation

This section describes how to check Σ -Series products on delivery and how to install them.

2.2.1 Checking on Delivery

When Σ -Series products are delivered, check the following items:

Check Items	Remarks
Check if the delivered products are the ones you ordered.	Check the models marked on the nameplates of Servomotor and SERVOPACK (see the table below).
Check if the motor shaft rotates smoothly.	If the motor shaft is smoothly turned by hand, it is normal. However, if the motor has brakes, it cannot be turned manually.
Check for damage.	Check the overall appearance, and check for damage or scratches resulting from transportation.
Check screws for looseness.	Check for looseness by using a screwdriver as necessary.

If any of the above items are faulty or incorrect, contact the dealer from which you purchased the products or your nearest local sales representative.

■ Servomotors

Appearance and Nameplate

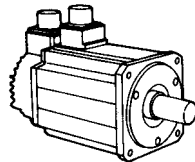

Σ -Series Servomotor

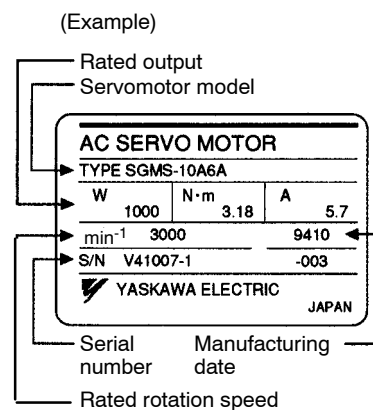

Models

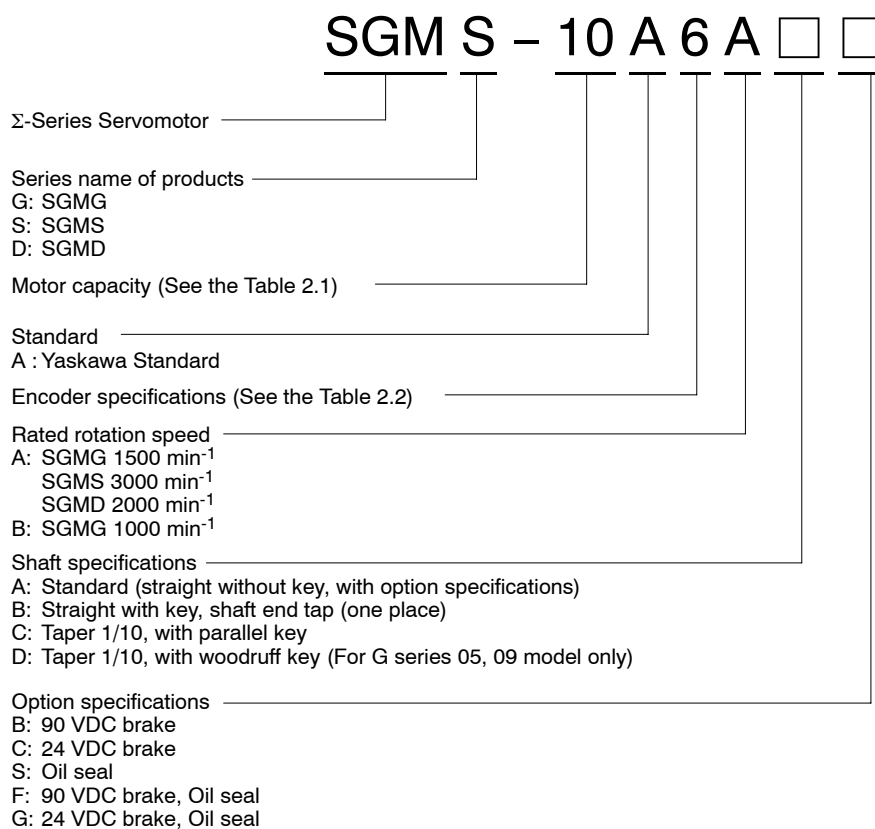

Table 2.1

(kW)

Series Code	G		S	D	Series Code	G		S	D
	1500 min ⁻¹	1000 min ⁻¹	3000 min ⁻¹	2000 min ⁻¹		1500 min ⁻¹	1000 min ⁻¹	3000 min ⁻¹	2000 min ⁻¹
03		0.3			30	2.9	3.0	3.0	
05	0.45				32				3.2
06		0.6			40			4.0	4.0
09	0.85	0.9			44	4.4	4.4		
10			1.0		50			5.0	
12		1.2			55	5.5			
13	1.3				60		6.0		
15			1.5		75	7.5			
20	1.8	2.0	2.0		1A	11.0			
22				2.2	1E	15.0			

Table 2.2

Code	Specification	SGMS	SGMG	SGMD
2	8192 P/R incremental	○	⊙	○
6	4096 P/R incremental	⊙	○	○
W	12 bit absolute	○	○	⊙
S	15 bit absolute	○	○	○

⊙: Standard ○: Semi-standard

Note: Refer to 6.1.1 *Selecting a Servomotor* for details on identifying the SGM and SGMP models.

2

■ **SERVOPACKs**

Appearance and Nameplate

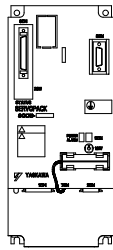

Σ-Series SGDB
SERVOPACK

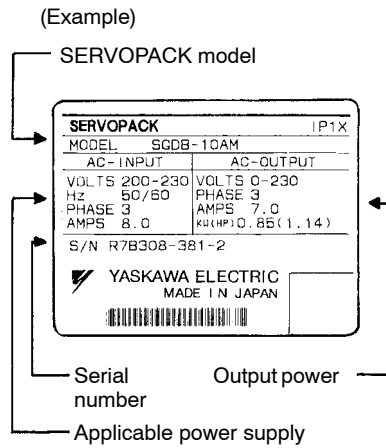

Models

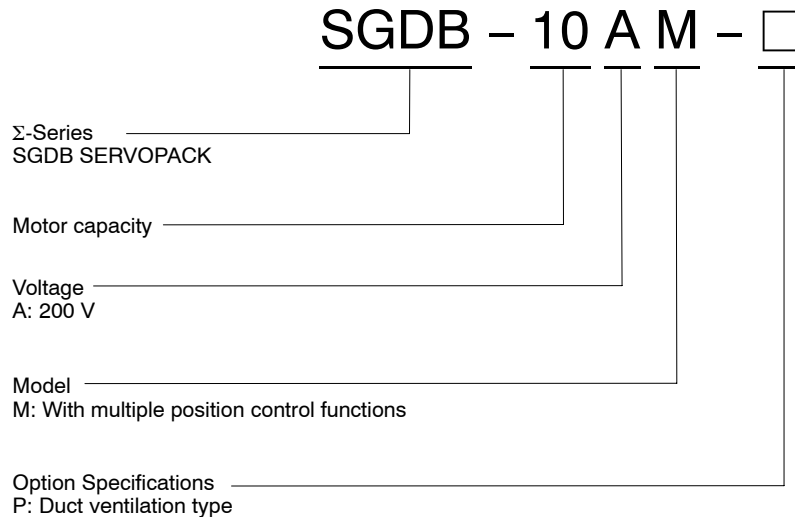

Code	Capacity (kW)	Code	Capacity (kW)
02	0.2	50	5.0
05	0.5	60	6.0
10	1.0	75	7.5
15	1.5	1A	11.0
20	2.0	1E	15.0
30	3.0		

2.2.2 Installing a Servomotor

Servomotor SGM□ models can be installed either horizontally or vertically. However, if the Servomotor is installed incorrectly or in an inappropriate location, the service life will be shortened or unexpected problems will occur. To prevent this, always observe the installation instructions described below.

■ Before Installation

Anticorrosive paint is coated on the edge of the motor shaft to prevent it from rusting during storage. Clean off the anticorrosive paint thoroughly using a cloth moistened with thinner before installing the motor.

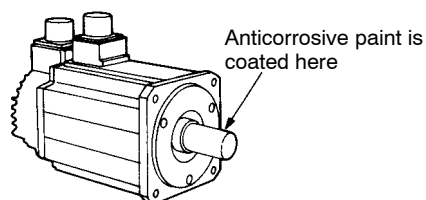

IMPORTANT

When cleaning off the anticorrosive paint, do not allow thinner to come into contact with other parts of the Servomotor.

■ Storage

When the Servomotor is to be stored with the power cable disconnected, store it in the following temperature range:

Between -20 and 60°C

■ Installation Sites

The Servomotor SGM□ modes are designed for indoor use. Install Servomotor in an environment which meets the following conditions:

- Indoor and free from corrosive and explosive gases

- Well-ventilated and free from dust and moisture
- Ambient temperature of 0 to 40°C
- Relative humidity of 20% to 80% (non-condensing)
- Inspection and cleaning can be performed easily

If the Servomotor is used in a location subject to water or oil mist, the motor can be protected by taking necessary precautions at the motor. However, if the **shaft opening** is to be sealed, specify the motor with oil seal.

Install with the electrical connector facing downward.

■ **Alignment**

Align the shaft of the Servomotor with that of the equipment to be controlled, then connect the shafts with couplings. Install the Servomotor so that alignment accuracy falls within the range shown below.

Measure this distance at four different positions in the circumference.
The difference between the maximum and minimum measurements must be 0.03 mm or less.
(Turn together with couplings)

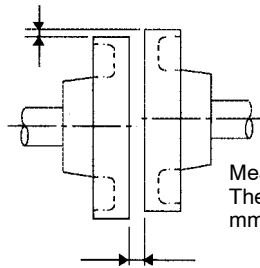

Measure this distance at four different positions in the circumference.
The difference between the maximum and minimum measurements must be 0.03 mm or less. (Turn together with couplings)

IMPORTANT

1. If the shafts are not aligned properly, vibration will occur, resulting in damage to the bearings.
2. Mount couplings carefully. A direct shock to the shaft may damage the encoder attached to the shaft on the end opposite the load.

■ **Allowable Shaft-end Load Range**

Perform a mechanical design so that **thrust load and radial load** applied to the servomotor shaft end falls within the range given in the following table.

Allowable radial loads shown below are the maximum values that could be applied to the shaft end.



◆ **Shaft opening**

Refers to the space where the shaft comes out from the motor.

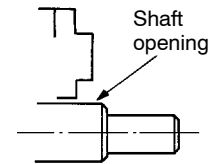

◆ **Thrust load and radial load**

Thrust load (Fs): Shaft-end load applied parallel to the center line of a shaft

Radial load (Fr): Shaft-end load applied perpendicular to the center line of a shaft

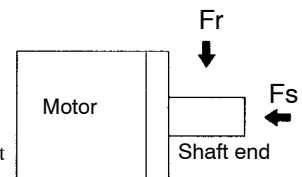
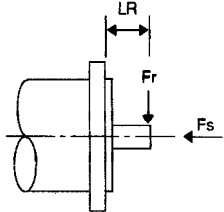

Table 2.3 Servomotors with Incremental Encoders

Motor Model	Allowable Radial Load Fr [N(lb)]	Allowable Thrust Load Fs [N(lb)]	LR [mm(in.)]	Reference Drawing
SGMG -05A□A -09A□A -13A□A -20A□A -30A□A -44A□A -55A□A -75A□A -1AA□A -1EA□A	490 (110)	98 (22)	58 (2.28)	
	490 (110)	98 (22)		
	686 (154)	343 (77)		
	1176 (264)	490 (110)	79 (3.11)	
	1470 (331)	490 (110)		
	1470 (331)	490 (110)		
	1764 (397)	588 (132)	113 (4.45)	
	1764 (397)	588 (132)		
	1764 (397)	588 (132)	116 (4.57)	
4998 (1124)	2156 (485)	116 (4.57)		
SGMG -03A□B -06A□B -09A□B -12A□B -20A□B -30A□B -44A□B -60A□B	490 (110)	98 (22)	58 (2.28)	
	490 (110)	98 (22)		
	686 (154)	343 (77)		
	1176 (264)	490 (110)	79 (3.11)	
	1470 (331)	490 (110)		
	1470 (331)	490 (110)		
	1764 (397)	588 (132)	113 (4.45)	
	1764 (397)	588 (132)		
SGMS -10A -15A -20A -30A -40A -50A	686 (154)	196 (44)	45 (1.77)	
	686 (154)	196 (44)		
	686 (154)	196 (44)		
	980 (220)	392 (88)	63 (2.48)	
	1176 (264)	392 (88)		
	1176 (264)	392 (88)		
SGMD -22A -32A -40A	1176 (264)	490 (110)	55 (2.17)	
	1176 (264)	490 (110)		
	1176 (264)	490 (110)	65 (2.56)	
SGM -02A -04A -08A	245 (55)	74 (17)	25 (0.98)	
	245 (55)	74 (17)		
	392 (88)	147 (33)	35 (1.38)	
SGMP -02A -04A -08A -15A	245 (55)	68 (15)	25 (0.98)	
	245 (55)	68 (15)		
	392 (88)	147 (33)	35 (1.38)	
	490 (110)	147 (33)		

2.2.3 Installing a SERVOPACK

Σ-Series SGDB SERVOPACK is a base-mounted servo controller. Incorrect installation will cause problems. Always observe the installation instructions described below.

■ Storage

When the SERVOPACK is to be stored with the power cable disconnected, store it in the following temperature range:

Between -20 and 85°C

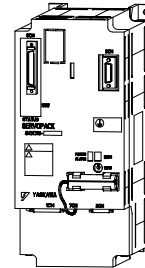

SGDB SERVOPACK

■ Installation Sites

The following table lists some precautions on installation sites.

Situation	Precautions on Installation
When installed in a control panel	Design the control panel size, unit layout, and cooling method so that the temperature around the periphery of the SERVOPACK does not exceed 55°C .
When installed near a heating unit	Suppress radiation heat from the heating unit and a temperature rise caused by convection so that the temperature around the periphery of the SERVOPACK does not exceed 55°C .
When installed near a source of vibration	Install a vibration isolator underneath the SERVOPACK to prevent it from receiving vibration.
When installed in a place receiving corrosive gases	Corrosive gases do not immediately affect the SERVOPACK but will eventually cause contactor-related devices to malfunction. Take appropriate action to prevent corrosive gases.
Others	Avoid installation in a hot and humid place or where excessive dust or iron powder is present in the air.

■ Orientation

Install the SERVOPACK perpendicular to the wall as shown in the figure.

The SERVOPACK must be orientated as shown in the figure.

Secure the SERVOPACK securely to the wall using three or four of the mounting holes provided.

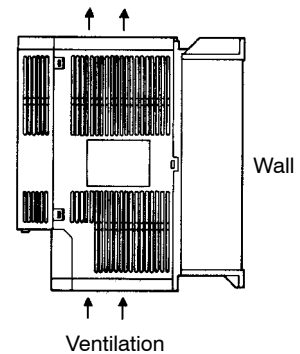

■ Installation Method

When installing multiple SERVOPACKs side by side in a control panel, observe the following installation method:

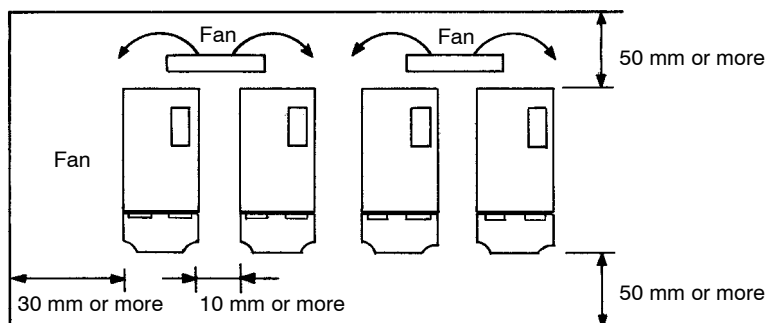

Orientation

Install SERVOPACK perpendicular to the wall so that the front panel (Digital Operator mounted face) faces outward.

Cooling

Provide sufficient space around each SERVOPACK to allow cooling by fan and natural convection.

Installing Side by Side

When installing SERVOPACKs side by side, provide at least 10 mm space between them and at least 50 mm space above and below them as shown in the figure above. Install cooling fans above the SERVOPACKs to prevent the temperature around each SERVOPACK from increasing excessively and also to maintain the temperature inside the control panel evenly.

Conditions Inside the Control Panel

- Ambient temperature for SERVOPACK: 0 to 55°C
- Humidity: 90% RH or less
- Vibration: 0.5 G (4.9 m/s²)
- Altitude: 1,000 m or less
- Condensation and freezing: None
- Ambient temperature to ensure long-term reliability: 45°C or less

2.2.4 Power Losses

The power losses of the SERVOPACKs at rated output are given below:

SERVOPACK Model	Output Current (RMS Value) A	Power Loss in Main Circuit W	Power Loss of Regenerative Resistor W	Power Loss in Control Circuit W	Power Loss in Total W
SGDB-02AM	2.0	14	30	20	64
SGDB-05AM	3.8	27			77
SGDB-10AM	7.6	55			105
SGDB-15AM	11.6	80			130
SGDB-20AM	18.5	120			170
SGDB-30AM	24.8	170		22	222
SGDB-50AM	32.9	220	-	27	247
SGDB-60AM	46.9	290			317
SGDB-75AM	54.7	330			357
SGDB-1AAM	58.6	360		30	390
SGDB-1EAM	78.0	490			520

The power loss of the regenerative resistor is the allowable loss. If the loss exceeds the allowable loss, the regenerative resistor inside the SERVOPACK should be removed and a regenerative resistor connected externally. Because the models in which the regenerative resistor is externally connected fall into non-standard specification categories, contact Yaskawa for further information.

For SGDB-50AM to 1EAM models, the regenerative resistor is placed separately.

The regenerative resistor unit provided from Yaskawa is described in *3.18.4 Using Regenerative Resistor Units*.

The power loss for JUSP-RA04 (for SGDB-50AM or SGDB-60AM) is 180 W, and for JUSP-RA05 (for SGDB-75AM, SGDB-1AAM, or SGDB-1EAM) is 350 W.

2.3 Connection and Wiring

This section describes how to connect Σ -Series products to peripheral devices and explains a typical example of wiring the main circuit. It also describes an example of connecting to main host controllers.

2.3.1 Connecting to Peripheral Devices

This section shows a standard example of connecting Σ -Series products to peripheral devices and briefly explains how to connect to each peripheral device.

2.3.1 Connecting to Peripheral Devices

2

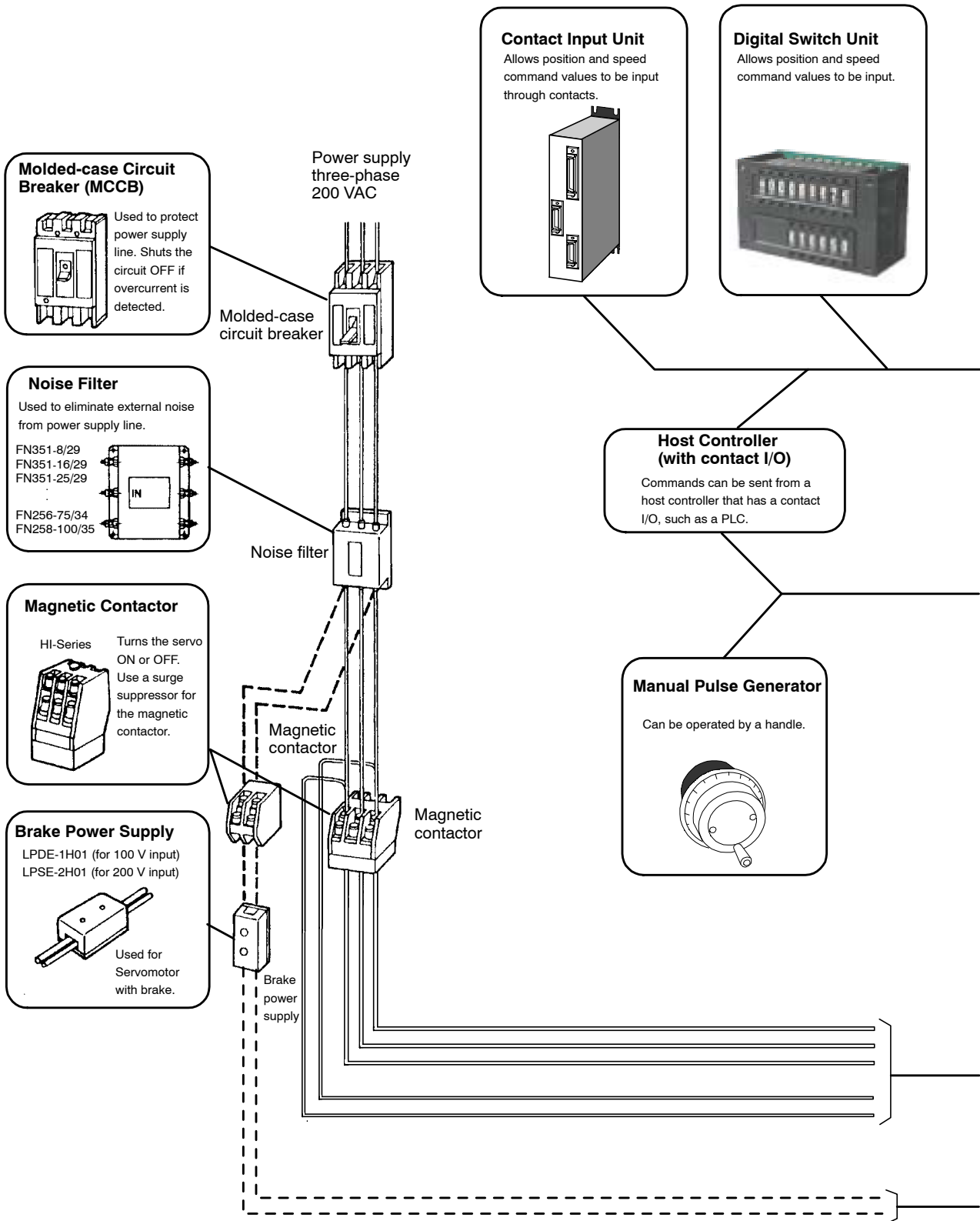

External Position Indicator

Indicates the current position.

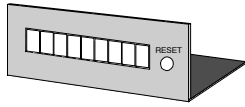

Host Controller (with RS-422A interface)

Serial commands can be sent from a host controller with an RS-422A interface. Up to 32 SGDB-□□AM Units can be connected to a serial interface port.

- Connector kit for 1CN, 3CN and 6CN.
- Connector terminal block conversion unit for cable with 1CN or 6CN connector and the other end without connector.
- Peripheral device connection cables
Refer to the next page for details.

Digital Operator

Allows the user to set parameters and tables, and displays operation command status and alarm status. Two models of Digital Operator can be selected. Communications with a personal computer are also possible.

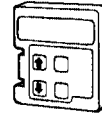

Mounted Operator (JUSP-OP03A)

This model can be mounted directly on the SERVOPACK.

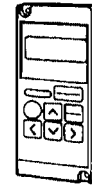

Hand-held Operator (JUSP-OP02A-1)

1-meter (3.3ft.) cable included

Personal Computer



A different connector cable is required according to the type of personal computer. Refer to the next page for details.

Cable for Encoder Connector for Encoder

Refer to the next page for details.

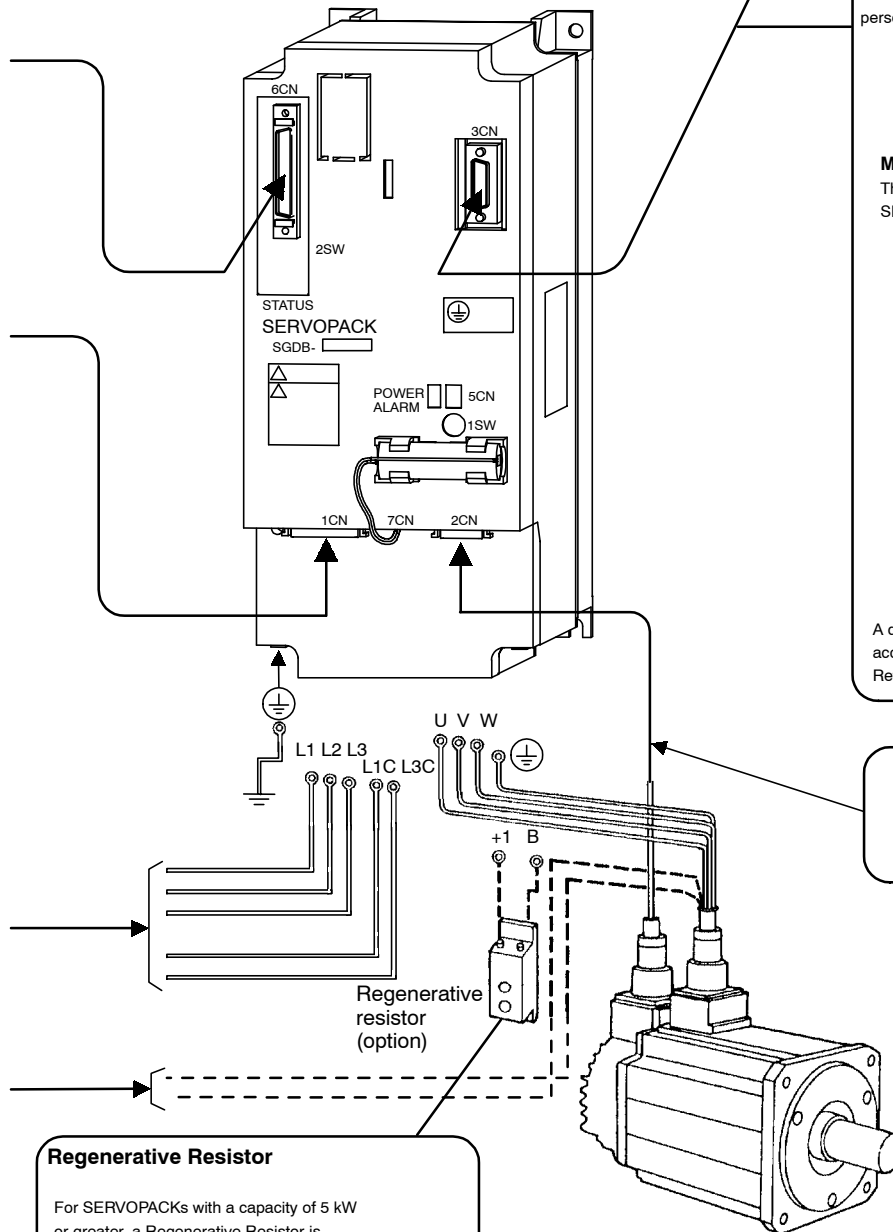

Regenerative Resistor

For SERVOPACKs with a capacity of 5 kW or greater, a Regenerative Resistor is mounted separately. The Regenerative Resistor is connected between +1 and B terminals.

■ **Cable for Personal Computer**

For IBM PC/AT or compatible computer: DE9408565

■ **Connector Terminal Block Conversion Unit for 1CN and 6CN**

The terminal block allows connection to a host controller.

For 1CN: JUSP-TA36Z

For 6CN: JUSP-TA50P

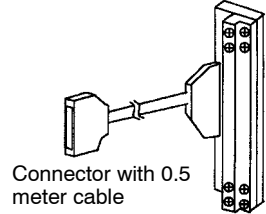

■ **Cable with a 1CN or 6CN Connector and One End without Connector**

For 1CN

1 m (3.3ft): JZSP-VBI14-01

2 m (6.6ft): JZSP-VBI14-02

3 m (9.8ft): JZSP-VBI14-03

For 6CN

1 m (3.3ft): JZSP-CKI01-1

2 m (6.6ft): JZSP-CKI01-2

3 m (9.8ft): JZSP-CKI01-3

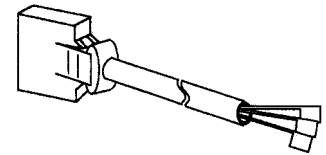

■ **1CN, 3CN, and 6CN Connector Kits**

For 1CN: JZSP-VAI09

For 3CN: DE9409459

For 6CN: DE9411289



■ **Connector Cable for Digital Switch Unit and Contact Input Unit**

This cable can be used both to connect the Digital Switch Unit to the SERVOPACK, and to connect the Contact Input Unit to the SERVOPACK.

1 m (3.3ft): JZSP-VBX24-01

2 m (6.6ft): JZSP-VBX24-02

3 m (9.8ft): JZSP-VBX24-03

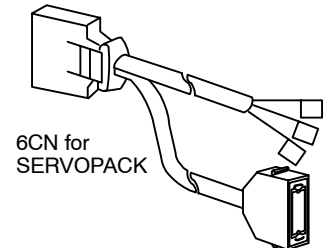

1CN for Digital Switch Unit or 3CN for Contact Input Unit

■ Digital Switch Unit Connector Kit (JZSP-VBX22)

This kit is a set of connectors for connecting a Digital Switch Unit and a SERVOPACK.

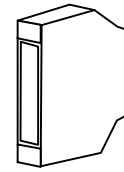

6CN for
SERVOPACK

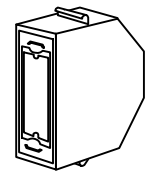

1CN for Digital
Switch Unit

■ Contact Input Unit Connector Kit

This 6CN Connector Kit (DE9411289) is used with the connector provided with the Contact Input Unit.



6CN for
SERVOPACK

■ Cable for External Position Indicator

This cable is used to connect an external position indicator to a SERVOPACK.

1 m (3.3ft): JZSP-VBX10-01

2 m (6.6ft): JZSP-VBX10-02

3 m (9.8ft): JZSP-VBX10-03

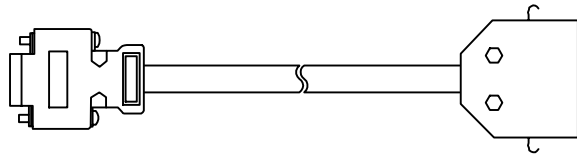

3CN for
SERVOPACK

1CN for External Position Indicator

■ External Position Indicator Connector Kit (JZSP-VBX12)

This kit includes a set of connectors for connecting an external position indicator and a SERVOPACK.

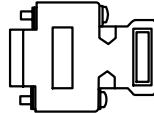

3CN for
SERVOPACK

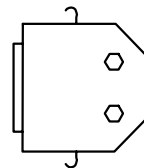

1CN for External
Position Indicator

■ **Cable for Manual Pulse Generator (Without Connector on Separated Ends)**

This cable separates the manual pulse generator signal lines from another signal lines.

- 1 m (3.3ft): JZSP-VBX04-01
- 2 m (6.6ft): JZSP-VBX04-02
- 3 m (9.8ft): JZSP-VBX04-03

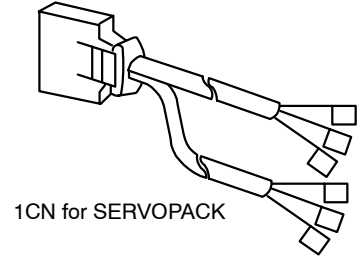

■ **Cable for PG**

This cable is used to connect the encoder of Servomotor to the SERVOPACK.

The following three types of cables are available according to encoder types.

SGMG, SGMS, and SGMD

- Cables with One Connector (without Connector on Encoder End)

Length	Cable Model	
	Incremental	Absolute
3m (9.8ft)	JZSP-VEP01-1	JZSP-VEP11-1
5m (16.4ft)	JZSP-VEP01-2	JZSP-VEP11-2
10m (32.8ft)	JZSP-VEP01-3	JZSP-VEP11-3
15m (49.2ft)	JZSP-VEP01-4	JZSP-VEP11-4
20m (65.6ft)	JZSP-VEP01-5	JZSP-VEP11-5

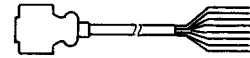

- Cables with Connectors on Both Ends (Straight Plug on Encoder End)

Length	Cable Model	
	Incremental	Absolute
3m (9.8ft)	JZSP-CBP0S-01	JZSP-CBP1S-01
5m (16.4ft)	JZSP-CBP0S-02	JZSP-CBP1S-02
10m (32.8ft)	JZSP-CBP0S-03	JZSP-CBP1S-03
15m (49.2ft)	JZSP-CBP0S-04	JZSP-CBP1S-04
20m (65.6ft)	JZSP-CBP0S-05	JZSP-CBP1S-05

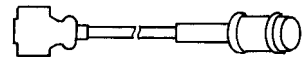

- Cables with Connectors on both Ends (L-shape Plug on Encoder End)

Length	Cable Model	
	Incremental	Absolute
3m (9.8ft)	JZSP-CBP0L-01	JZSP-CBP1L-01
5m (16.4ft)	JZSP-CBP0L-02	JZSP-CBP1L-02
10m (32.8ft)	JZSP-CBP0L-03	JZSP-CBP1L-03
15m (49.2ft)	JZSP-CBP0L-04	JZSP-CBP1L-04
20m (65.6ft)	JZSP-CBP0L-05	JZSP-CBP1L-05

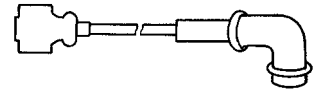

2

For Models SGM, SGMP

- Cables with Connectors on Both Ends

Length	Cable Model	
	Incremental	Absolute
3m (9.8ft)	JZSP-CAP00-01	JZSP-CAP10-01
5m (16.4ft)	JZSP-CAP00-02	JZSP-CAP10-02
10m (32.8ft)	JZSP-CAP00-03	JZSP-CAP10-03
15m (49.2ft)	JZSP-CAP00-04	JZSP-CAP10-04
20m (65.6ft)	JZSP-CAP00-05	JZSP-CAP10-05

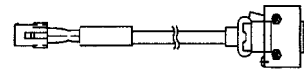

- Cables with One Connector (without Connector on SERVOPACK End)

Length	Cable Model	
	Incremental	Absolute
3m (9.8ft)	DP9320086-1	DP9320085-1
5m (16.4ft)	DP9320086-2	DP9320085-2
10m (32.8ft)	DP9320086-3	DP9320085-3
15m (49.2ft)	DP9320086-4	DP9320085-4
20m (65.6ft)	DP9320086-5	DP9320085-5

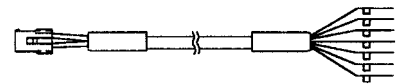

- Cables without Connectors

Length	Cable Model	
	Incremental	Absolute
3m (9.8ft)	DP9400064-1	DP8409123-1
5m (16.4ft)	DP9400064-2	DP8409123-2
10m (32.8ft)	DP9400064-3	DP8409123-3
15m (49.2ft)	DP9400064-4	DP8409123-4
20m (65.6ft)	DP9400064-5	DP8409123-5



■ Connector Kit (DE9411290) for PG

Connector on SERVOPACK end only.

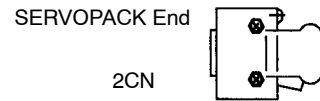

2.3.2 Main Circuit Wiring and Power ON Sequence

This section describes the functions of the main circuit terminals, the main circuit wiring, and the power-ON sequence of a typical Σ-Series Servo.

■ Functions of Main Circuit Terminals

The following table shows the name and description of each main circuit terminal:

Terminal Symbol	Name	Description
L1, L2, L3	Main power input terminals	Three-phase 200 to 230 VAC $+10_{-15}$ %, 50/60 Hz
U, V, W	Motor connection terminal	Used to connect motor
L1C, L3C	Control power input terminals	Single phase 200 to 230 VAC $+10_{-15}$ %, 50/60 Hz
⊕ × 2	Ground terminal	Connected to earth. (For power ground and motor ground).
+, B	Regenerative resistor unit connection terminal	Normally, external connection is not required.
+1, B	Regenerative resistor unit connection terminal	Terminal used to connect regenerative resistor for SERVOPACK with power capacity more than 5 kW.
N	Main circuit negative terminal	Normally, external connection is not required.

Note: A SERVOPACK with power capacity of 3 kW or less does not have a +1 terminal.

Typical Wiring Example

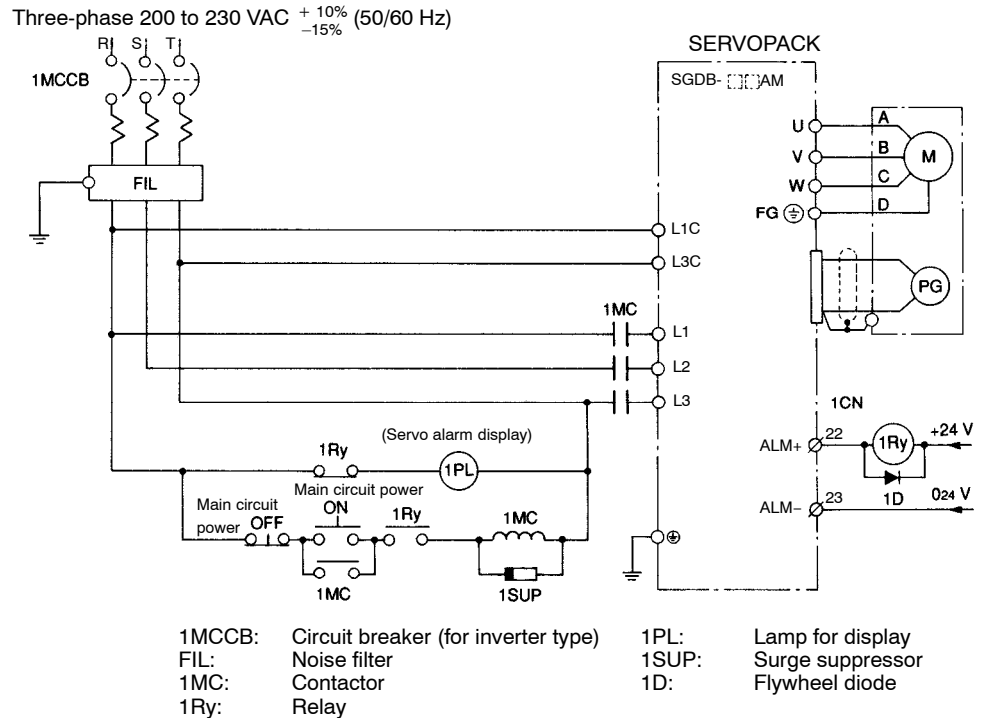

Power ON Sequence Design

Form a power ON sequence as follows:

- Form a power ON sequence so that the main power is turned OFF when a servo alarm signal is output. (See the circuit diagram above.)
- The SERVOPACK outputs a servo alarm signal for approximately two seconds or less when the control power is turned ON. This operation is required to initialize the SERVOPACK.

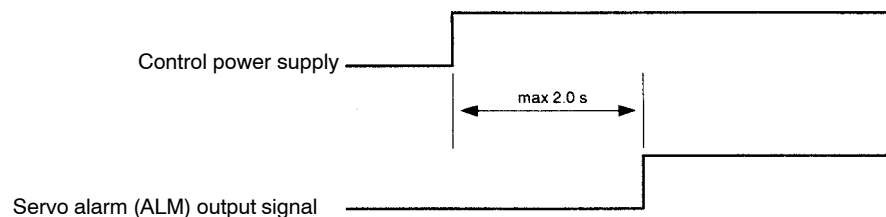

■ Wiring Precautions

- Do not wire power lines and signal lines in the same duct or bundle them together.
Wire such that signal lines are kept apart from power lines by at least 30 cm.
- Twisted pair wire and shielded multi-core twisted-pair wires should be used for signal lines, encoder (PG) feedback lines.
The length for wiring is 5 m maximum for the command input line, 20 m maximum for the PG feedback line.
- Do not touch the power terminal even if power was turned OFF.
High voltage may still remain in SERVOPACK.
Perform inspection only after the CHARGE lamp is OFF.
- Do not turn the power ON and OFF frequently.
Since the SGDB SERVOPACK has a capacitor in the power supply unit, a high charging current will flow for approximately 0.2 seconds when power is turned ON.
Therefore, frequently turning the power ON and OFF causes the main circuit devices (such as capacitors and fuses) to deteriorate, resulting in unexpected problems.

2.4 Conducting a Test Run

This section describes how to conduct a full test run. The test run is divided into two steps. Complete a test run in step 1 first, then proceed to step 2.

2.4.1 Test Run in Two Steps

Conduct the test run when wiring is complete. Generally, conducting a test run for servo drives can be difficult. However, by following the two steps described below, the test run can be performed safely and correctly.

2

IMPORTANT

To prevent accidents, initially conduct a test run only for a servomotor under no load (i.e., with all couplings and belts disconnected). Do not run the servomotor while it is connected to a machine.

Step 1: Conducting a test run for the motor without load

Check that the motor is wired correctly.

Conduct a test run with the motor shaft disconnected from the machine.

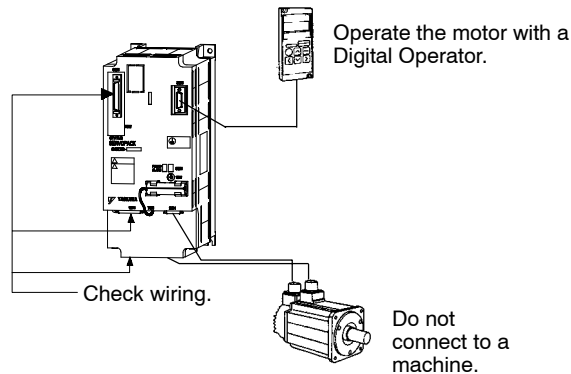

Step 2: Conducting a test run with the motor and machine connected

Adjust SERVOPACK according to machine characteristics.

Connect to the machine and conduct a test run.

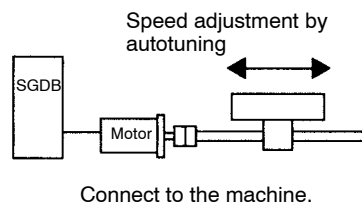

2.4.2 Step 1: Conducting a Test Run for Motor without Load

Check that the motor is wired correctly.

If the motor fails to rotate properly during a servo drive test run, the cause most frequently lies with incorrect wiring.

- Check power supply circuit wiring.
- Check servomotor wiring.
- Check I/O signal wiring (1CN and 6CN).

Wherever possible, perform host controller adjustments and other relevant operations in Step 1 (before installing a Servomotor on the machine).

Conduct a test run for the motor without load according to the procedure described below.

For customers who use a servomotor with brake, refer to *2.4.4 Supplementary Information on Test Run* before starting a test run.

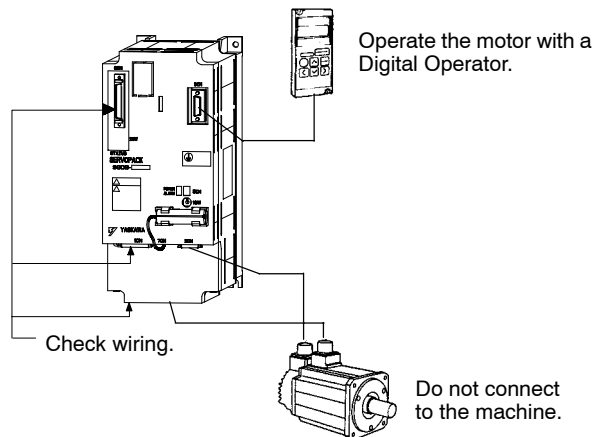

■ Securing the Servomotor

Secure the servomotor to mounting holes to prevent it from moving during operation. Alternatively, disconnect couplings and belts.

Secure servomotor to mounting holes.

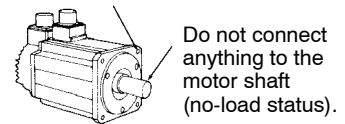

■ Checking the Servomotor Wiring

Disconnect connector 1CN and 6CN, then check the motor wiring in the power supply circuit. I/O signals (1CN and 6CN) are not to be used so leave connector 1CN and 6CN disconnected.

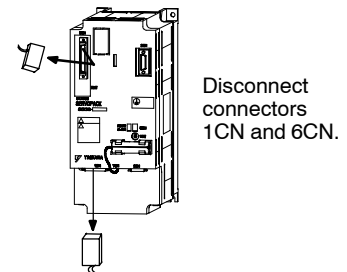

■ Turning the Power ON

Turn ON the SERVOPACK. If the SERVOPACK is turned ON normally, the POWER indicator on the front panel will light.

Sending an ALM command through the serial communications line will return an “ALM P.P-OT” response. If a Digital Operator is connected, the display will appear as shown below.

The indicator on the Digital Operator will light as shown in the figure.

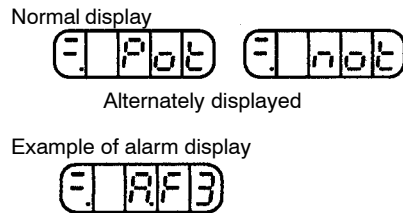

Power is not supplied to the servomotor because the servo is OFF.

If an alarm display appears on the LED as shown in the figure above, the power supply circuit, motor wiring or encoder wiring is incorrect. In this case, turn the power OFF, then correct the problem. Refer to *Appendix D List of Alarm Displays*.

■ Operation by Serial Communications

Run the servomotor by sending a serial command. Check that the servomotor is running normally.

Refer to *4.2 Serial Communications Commands* for details on the operation method.

■ Operation Using Digital Operator

If serial communications cannot be executed and a Digital Operator is installed, use the Digital Operator to run the servomotor, and check that it is running normally.

Refer to *5.2.2 Operation Using the Digital Operator*.

Operate Using Digital Operator.

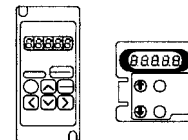

If an alarm occurs, the power supply circuit, motor wiring, or encoder wiring is incorrect.

■ Connecting Signal Lines

Use the following procedure to attach the 1CN and 6CN connectors.

1. Turn OFF the power.
2. Connect connectors 1CN and 6CN.
3. Turn ON the power again.

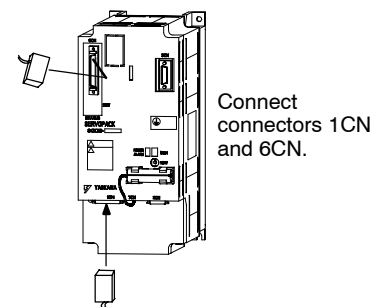

2

■ Checking Input Signals

Check the input signal wiring either by using a serial communications monitor command, or by using the monitor mode of the Digital Operator.

For details on the operation method, refer to 4.2.2 *Reading Data from a SERVOPACK* and 5.1.11 *Monitor Mode*.

To check input signals, turn each connected signal line ON and OFF, and verify that the bit display on the monitor changes as indicated in the table below.

Input Signal	ON/OFF	Serial Monitor Command Response	Monitor Bit Display on Digital Operator
High level or open	OFF	1	Not lit
Low level or closed	ON	0	Lit

If the signal lines are not wired correctly, the servomotor may not rotate. Make sure wiring is correct. If a signal line is not being used, short it out as necessary. Memory switch settings can be used to eliminate the need to perform external short-circuit wiring.

Signal Symbol	Connector Pin Number	Explanation
P-OT	1CN-30	Servomotor can rotate forward when input from signal line is 0 V.
N-OT	1CN-31	Servomotor can reverse when input from signal line is 0 V.
/S-ON	1CN-28	Servomotor is turned ON when input from signal line is 0 V. This line need not be connected when serial commands SVON and SVOFF are used. Leave the servomotor in OFF state at this time.
STOP	6CN-24	Servomotor can be operated in automatic mode and zero point return mode when input from signal line is 0 V.

■ Turning ON the Servo

Use the following procedure to turn ON the servo.

1. Check that no command has been input.
 - Turn OFF /AST (6CN-22), /ZRN (6CN-13), /MAN (6CN-14), /PULS (6CN-15), /MCW (6CN-16), and /MCCW (6CN-17).
 - When using digital switches, set the position and speed command values to 0.
 - When using the serial communications, stop serial communications.
 - When using pulses, set PULS (1CN-3) and SIGN (1CN-6) to 0 V.

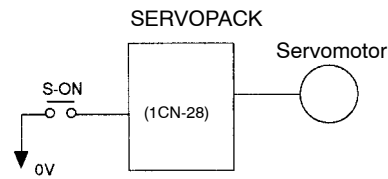

Turn ON the servo.

2. Turn ON the servo.

Either set /S-ON signal (1CN-28) to 0V, or send the serial command SVON. In normal circumstances, the servomotor will be turned ON, and COIN will be returned in response to the ALM serial command.

If a Digital Operator is connected, its display will be as shown in the figure on the right.

Display when servo is turned ON



■ Operation by Command Input

In automatic mode, the operating procedure differs according to the positioning mode (Cn-27) setting.

After referring to *Chapter 3*, set the command speed and command position, and start the servomotor.

Incorrect wiring or a command input error or parameter setting error can cause the motor to overrun. When turning ON the servomotor, be sure to be in a position to perform an emergency stop at any time.

1. Slow down the command speed (to 100 min^{-1} or less), then set the position command and enter an operation start command.

The method of entering the speed and position commands differs according to the positioning mode. Enter values according to the current positioning mode.

When the command table method is used, it is necessary to write the command values in the position table and speed table in advance. Refer to either *4.2.1 Sending Commands to a SERVOPACK* and *4.4 Serial Commands for Settings and Monitoring*, or to *5.1.8 Position Table Setting Mode* and *5.1.9 Speed Table Setting Mode*, as appropriate.

2. Use the serial communications monitor command or the monitor mode of the Digital Operator to check the following items:

Monitor Command	Digital Operator Un Number	Content of Monitor
MON0	Un-00	Actual rotation speed of servomotor (min^{-1})
MON1	Un-01	Command speed ($\times 1000$ command units/min)
MONF	Un-0F	Current position (command units)

2.4.3 Step 2: Conducting a Test Run with the Motor Connected to the Machine

- Does the motor rotate?
- Does the motor stop at the command position?
- Do the speed command and rotation speed match? (If the positioning distance is too short, positioning may be completed before the motor speed reaches the command speed.)
- Is the motor rotating in the desired direction?

3. When changing the direction of rotation or the command unit, reset the following parameters:

Cn-23 to Cn-25	Electronic Gear Ratio
Cn-02 bit 0	Reverse rotation mode

If the above operation produces an alarm or the servomotor fails to operate, either the 1CN or 6CN wiring is incorrect, or the parameter settings do not agree with the specifications of the host controller. Check the wiring or review the parameter settings, then repeat step 1 above.

For details, refer to *Appendix C List of Parameters* and *Appendix D List of Alarm Displays*.

2.4.3 Step 2: Conducting a Test Run with the Motor Connected to the Machine



WARNING

- Operation faults that arise after the motor is connected to the machine not only damage the machine but may also cause an accident resulting in injury or death.

Before proceeding to step 2, repeat step 1 (conducting a test run for the motor without load) until you are fully satisfied that the test has been completed successfully. All items including parameters setting and wiring should be tested as conclusively as possible before step 1 is complete.

After step 1 is complete, proceed to step 2 in which a test run is conducted with the motor connected to the machine. The purpose of step 2 is to adjust the SERVOPACK according to the machine characteristics.

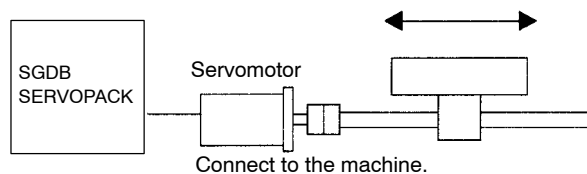
- To perform autotuning to adjust the motor according to machine characteristics
- To match the speed and direction of rotation with the machine specifications
- To check the final control mode



Conduct a test run according to the procedure described below.

1. Turn the SERVOPACK power OFF.
2. Connect the servomotor to the machine.
Refer to 2.2.2 *Installing a Servomotor*.
3. Tune the SERVOPACK according to the machine characteristics.
Refer to 5.2.3 *Autotuning*.
4. Operate by command input.
As in 2.4.2 *Step 1: Conducting a Test Run for Motor without Load*, perform *Operation by Command Input* on page 2 -27. Perform tuning associated with the host controller.
5. Set parameters and record the settings.
Set parameters as necessary. Record all the parameter settings for maintenance purposes.

This is all that is required to conduct the test run.

Normally, the machine may cause much friction because of an insufficient running-in period. After a test run is complete, perform adequate running-in.

2.4.4 Supplementary Information on Test Run

In the following cases, always refer to the information described below before starting a test run:

- When using a servomotor with a brake
- When performing position control from the host controller

■ When Using a Servomotor with Brake

The brake prevents the motor shaft from rotating due to a backdriving torque. Such a torque may be created by an external force or the force of gravity acting on the load and may result in undesired motion or the load, should motor power be lost.

SERVOPACK uses the brake interlock output (BK) signal to control holding brake operation for a servomotor with brake.

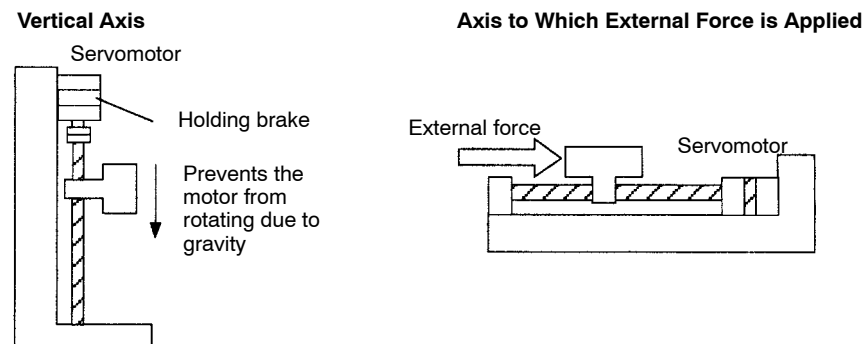

IMPORTANT

To prevent faulty operation caused by gravity (or external force), first check that the motor and holding brake operate normally with the motor disconnected from the machine. Then, connect the motor to the machine and conduct a test run.

For wiring of a servomotor with a brake, refer to 3.14.2 *Holding Brake*.

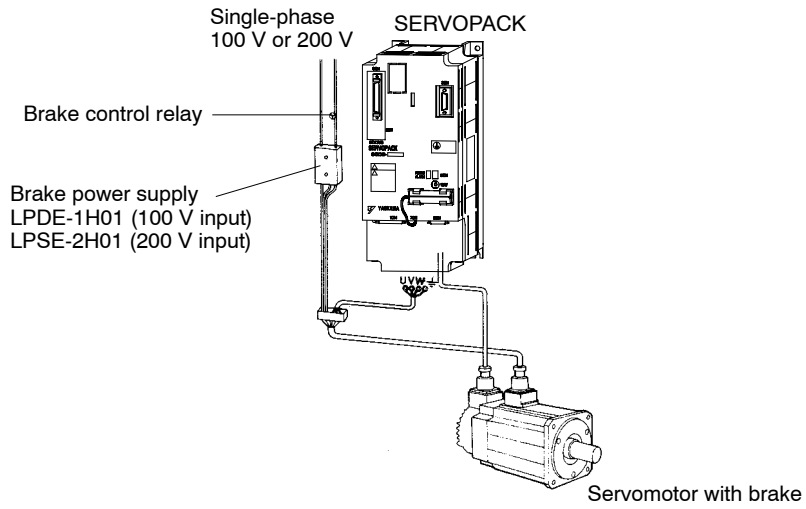

2

3

Advanced Use

This chapter explains how to set parameters for each purpose and how to use each function. Read the applicable sections according to your requirements.

Before Reading this Chapter	3 -4
3.1 Setting Up the Σ SERVOPACK	3 -5
3.1.1 Setting the Motor Model	3 -5
3.1.2 Setting the Number of Encoder Pulses	3 -6
3.1.3 Direction of Motor Rotation	3 -7
3.1.4 Parameter Settings for Machine System	3 -8
3.1.5 Electronic Gear	3 -9
3.1.6 Setting the Acceleration/Deceleration Type and Rate	3 -12
3.1.7 Setting Speed Limits	3 -16
3.1.8 Setting Torque Limits	3 -16
3.1.9 Setting Stored Stroke Limits	3 -19
3.1.10 Setting Backlash Compensation	3 -20
3.2 Signals Common to All Modes	3 -21
3.2.1 Servo ON Signal	3 -21
3.2.2 Pause Inputs	3 -22
3.2.3 Overtravel Limit Function	3 -25
3.2.4 Operation Mode Selection	3 -29
3.2.5 Operation Mode Display Output	3 -30
3.2.6 Operation Start Input	3 -31
3.2.7 Reset and Alarm Reset Input	3 -33
3.2.8 Servo Alarm Output	3 -34

3.2.9	Command Error Outputs	3 -35
3.2.10	Alarm Code Outputs	3 -37
3.2.11	Positioning Complete and Positioning Proximity Signals	3 -39
3.2.12	Servo Ready Output Signal	3 -42
3.2.13	Running Detection Signal	3 -43
3.2.14	OL Warning and Alarm Output Signals	3 -45
3.2.15	Analog Monitor Signals	3 -46
3.3	Feed Speed Setting in Automatic and Manual Operation Modes	3 -48
3.4	Automatic Mode: Station Numbers	3 -50
3.4.1	Position Command Input Signals	3 -52
3.4.2	Rotating Direction Select Input	3 -53
3.4.3	Current Station Number Output and Station Number Read Selection Input	3 -54
3.4.4	Station Proximity Signal	3 -56
3.4.5	Manual Operation Mode	3 -57
3.4.6	Inputting Speed Command Data	3 -57
3.5	Automatic Mode: Digital Switches	3 -60
3.5.1	Position Command Input Signals, Speed Command Input Signals, and Strobe Output Signals	3 -62
3.5.2	Speed Command	3 -66
3.5.3	Digital Switch Unit	3 -67
3.5.4	Contact Input Unit	3 -68
3.6	Automatic Mode: Serial Communications .	3 -70
3.6.1	Serial Commands	3 -72
3.7	Automatic Mode: Command Table	3 -88
3.7.1	Data Number Input Signals	3 -90
3.7.2	Zone Signal Outputs	3 -91
3.7.3	Speed Command Input	3 -94
3.8	Manual Mode	3 -95
3.9	Pulse Operation Mode	3 -96
3.10	Machine Zero Point Return Mode	3 -100
3.10.1	Machine Zero Point Return Mode I (Bits 2 and 3 of Cn-29 Set to 0)	3 -101
3.10.2	Machine Zero Point Return Mode II (Bits 2 and 3 of Cn-29 Set to 1 and 0 Respectively)	3 -102
3.10.3	Machine Zero Point Return Mode III (Bits 2 and 3 of Cn-29 Set to 1)	3 -102

3.11	Encoder Outputs	3 -104
3.12	External Pulse Generators	3 -107
3.13	External Position Indicator	3 -109
3.14	Setting the Stop Function	3 -111
	3.14.1 Dynamic Brake	3 -111
	3.14.2 Holding Brake	3 -112
3.15	Smooth Operation	3 -115
	3.15.1 Adjusting Gain	3 -115
	3.15.2 Setting the Torque Command Filter Time Constant	3 -116
3.16	Minimizing Positioning Time	3 -118
	3.16.1 Autotuning Function	3 -118
	3.16.2 Servo Gain Switching	3 -118
	3.16.3 Feed-forward Control	3 -119
	3.16.4 Speed Bias	3 -119
	3.16.5 Proportional Control	3 -120
	3.16.6 Mode Switch	3 -120
3.17	Handling Power Loss	3 -124
3.18	Special Wiring	3 -125
	3.18.1 Wiring Instructions	3 -125
	3.18.2 Wiring for Noise Control	3 -126
	3.18.3 Using More Than One Servodrive	3 -131
	3.18.4 Using Regenerative Resistor Units	3 -132
	3.18.5 Using an Absolute Encoder	3 -134
	3.18.6 Extending an Encoder Cable	3 -137
	3.18.7 Using SGDB SERVOPACK with High Voltage Lines	3 -140
	3.18.8 Connector Terminal Layouts	3 -141

Before Reading this Chapter

This chapter describes how to use each 1CN or 6CN connector I/O signals and how to set the corresponding parameter.

Other related sections in this manual are listed below.

- For a list of I/O signals of 1CN and 6CN connectors, refer to *Appendix B List of I/O Signals*.
- For terminal layout for I/O signals of 1CN and 6CN connectors, refer to *3.18.8 Connector Terminal Layouts*.
- For a list of parameters, refer to *Appendix C List of Parameters*.
- For details on how to set parameters using serial communications, refer to *4.4.1 List of Commands*.
- For details on how to set parameters using the Digital Operator, refer to *5.1.7 Parameter Setting Mode*.

The 1CN and 6CN connectors are used to output signals to and input them from external circuits or devices (e.g., host controllers).

Parameters are divided into the following two types.

Memory switches Cn-01, Cn-02, Cn-26, Cn-29, Cn-32, Cn-33 and Cn-39	Set each bit to ON or OFF to select a function.
Parameter settings Memory switches other than Cn-03 to Cn-3F	Set numerical values, such as a torque limit value or speed loop gain.

3.1 Setting Up the Σ SERVOPACK

This section describes how to set parameters.

3.1.1 Setting the Motor Model

To ensure that the Σ -series Servo System operates properly, set the model of the servomotor in the following parameter.

Cn-2A	Motor Code	Factory Settings: Shown below
--------------	------------	-------------------------------

Set this memory switch according to the servomotor model.

After changing this parameter setting, turn the power OFF, then ON.

SERVOPACK Model	Cn-2A Factory Setting	Motor Model	Cn-2A Setting (Motor Code)
SGDB-02AM	104	SGM-02A	104
		SGMP-02A	124
SGDB-05AM	142	SGMG-03A□B	171
		SGM-04A	106
		SGMP-04A	126
		SGMG-05A□A	142
SGDB-10AM	143	SGMG-06A□B	172
		SGM-08A	107
		SGMP-08A	127
		SGMG-09A□A	143
		SGMG-09A□B	173
		SGMS-10A□A	163
SGDB-15AM	144	SGMG-12A□B	174
		SGMG-13A□A	144
		SGMP-15A	128
		SGMS-15A□A	164
SGDB-20AM	145	SGMG-20A□A	145
		SGMG-20A□B	175
		SGMS-20A□A	165
SGDB-30AM	146	SGMD-22A□A	155
		SGMG-30A□A	146
		SGMG-30A□B	176
		SGMS-30A□A	166

SERVOPACK Model	Cn-2A Factory Setting	Motor Model	Cn-2A Setting (Motor Code)
SGDB-50AM	147	SGMD-32A□A	156
		SGMG-44A□A	147
		SGMG-44A□B	177
		SGMS-40A□A	167
		SGMD-40A□A	157
		SGMS-50A□A	168
SGDB-60AM	148	SGMG-55A□A	148
		SGMG-60A□B	178
SGDB-75AM	149	SGMG-75A□A	149
SGDB-1AAM	140	SGMG-1AA□A	140
SGDB-1EAM	150	SGMG-1EA□A	150

The motor model used can be changed within the same group.

3.1.2 Setting the Number of Encoder Pulses

To ensure that the Σ -series Servo System operates properly, set the encoder type and the number of encoder pulses in the following parameters:

Cn-01 Bit E	Encoder Type	Factory Setting: 0
--------------------	--------------	--------------------

Set the encoder type according to the servomotor model.

After changing the memory switch setting, turn the power OFF, then ON.

Encoder Specifications in Motor Model	Number of Encoder Pulses Per Revolution	Value
2	Incremental encoder: 8192 pulses per revolution	0
3	Incremental encoder: 2048 pulses per revolution	
6	Incremental encoder: 4096 pulses per revolution	
W	Absolute encoder: 1024 pulses per revolution	1
S	Absolute encoder: 8192 pulses per revolution	

Cn-11	Number of Encoder Pulses	Unit: Pulses Per Revolution (P/R)	Setting Range: 513 to 32768	Factory Setting: 8192
--------------	--------------------------	-----------------------------------	-----------------------------	-----------------------

Set the number of encoder pulses according to the servomotor model.

After changing this memory switch setting, turn the power OFF, then ON.

Encoder Specifications in Motor Model	Number of Encoder Pulses Per Revolution	Value
2	Incremental encoder: 8192 pulses per revolution	8192
3	Incremental encoder: 2048 pulses per revolution	2048
6	Incremental encoder: 4096 pulses per revolution	4096
W	Absolute encoder: 1024 pulses per revolution	1024
S	Absolute encoder: 8192 pulses per revolution	8192

3.1.3 Direction of Motor Rotation

This SERVOPACK provides a reverse rotation mode in which the direction of rotation can be reversed without altering the servomotor wiring.

3

If reverse rotation mode is used, the direction of motor rotation can be reversed without other changes.

With the standard setting, forward rotation is defined as counterclockwise (CCW) rotation viewed from the drive end.

Command	Standard Setting	Reverse Rotation Mode
Forward (+)	<p>Encoder output from SERVOPACK</p> <p>PAO (Phase A)</p> <p>PBO (Phase B)</p>	<p>Encoder output from SERVOPACK</p> <p>PAO (Phase A)</p> <p>PBO (Phase B)</p>
Reverse (-)	<p>Encoder output from SERVOPACK</p> <p>PAO (Phase A)</p> <p>PBO (Phase B)</p>	<p>Encoder output from SERVOPACK</p> <p>PAO (Phase A)</p> <p>PBO (Phase B)</p>

■ Setting Reverse Rotation Mode

Set bit 0 of memory switch Cn-02 to select reverse rotation mode.

Cn-02 Bit 0	Reverse Rotation Mode	Factory Setting: 0
--------------------	-----------------------	--------------------

Setting	Meaning
0	Forward rotation is defined as counterclockwise rotation when viewed from the drive end. (Standard setting)
1	Forward rotation is defined as clockwise rotation when viewed from the drive end. (Reverse rotation setting)

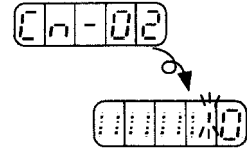

3.1.4 Parameter Settings for Machine System

Set bit 1 of memory switch Cn-26 according to the machine configuration.

Cn-26 Bit 1	Finite/infinite Length Mode Setting	Factory Setting: 0
--------------------	-------------------------------------	--------------------

Setting	Meaning
0	Finite length mode
1	Infinite length mode

If the machine has limited travel, set the memory switch bit to finite length mode. The stored stroke limit function becomes effective in this mode.

Refer to 3.1.9 *Setting Stored Stroke Limits* for information on the stored stroke limit function.

Mechanical configurations such as ball screws and transport trucks are examples of machines with limited travel.

If the machine has unlimited travel, set the memory switch bit to infinite length mode. The stored stroke limit function will not be effective in this mode.

Disc tables, press feeders, and conveyor belts are examples of machines with unlimited travel.

Cn-26 Bit 2	Linear/Rotational Mode	Factory Setting: 0
--------------------	------------------------	--------------------

Setting	Meaning
0	Linear mode
1	Rotational mode

For linear motion, set bit 2 of Cn-26 to 0 (linear mode). In this mode, the position coordinates can be in the range of -99999999 to +99999999 (command units).

For rotational motion, set bit 2 of Cn-26 to 1 (rotational mode). In this mode, the range for position coordinates is from 0 to Cn-23 - 1 (command units). Cn-23 is the number of command units per machine revolution. The position returns to the zero point after one revolution.

3.1.5 Electronic Gear

The electronic gear function enables the motor travel distance per input command unit to be set to any value. It allows the host controller to perform control without having to consider the machine gear ratio and the number of encoder pulses.

When Electronic Gear Function is not Used

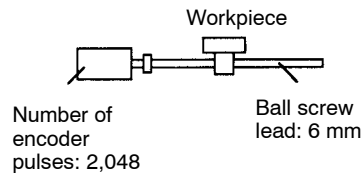

To move a workpiece 10 mm:

One revolution is equivalent to 6 mm, so
 $10 \div 6 = 1.6666$ (revolutions)

2048×4 (pulses) is equivalent to one revolution, so
 $1.6666 \times 2,048 \times 4 = 13,653$ (command unit)

A total of 13653 pulses must be input as the command unit.

The host controller needs to make this calculation.

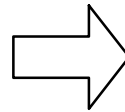

When Electronic Gear Function is Used

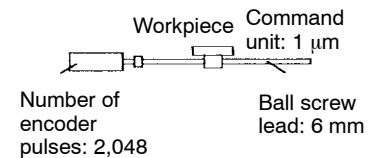

Machine conditions and command unit must be defined for the electronic gear function beforehand.

To move a workpiece 10 mm:

Command unit is 1 μ m, so

$10 \text{ mm} \div 1 \mu\text{m} = 10,000$ command units

■ Setting the Electronic Gear

Calculate the electronic gear ratio (B/A) according to the procedure below and set the value in Cn-23, Cn-24 and Cn-25.

1. Check the machine specifications.

Items related to electronic gear:

- Gear ratio
- Ball screw lead
- Pulley diameter

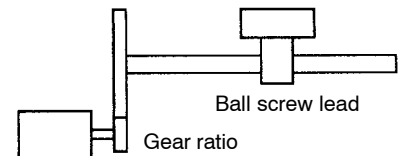

2. Determine the command unit to be used.

Command unit is the minimum unit of position data used for moving the load. (Minimum unit of command from host controller)

Examples:

0.01 mm, 0.001 mm, 0.1°, 0.01 inch

Command input of one unit moves the load by one command unit.

Example: When command unit is 1 μ m

If a command of 50,000 units is input, the load moves 50 mm ($50,000 \times 1 \mu\text{m}$).

To move a table in 0.001 mm units
 Command unit: 0.001 mm

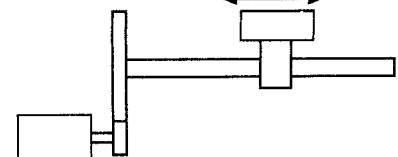

Determine the command unit according to machine specifications and positioning accuracy.

3. Determine the load travel distance per revolution of load shaft in command units.

Load travel distance per revolution of load shaft (in command units)

$$= \frac{\text{Load travel distance per revolution of load shaft (in unit of distance)}}{\text{Command unit}}$$

Example: When ball screw lead is 5 mm and command unit is 0.001 mm
 $5/0.001 = 5,000$ (command units)

4. Determine the electronic gear ratio $\left(\frac{B}{A}\right)$.

Check the electronic gear ratio so that the load (reduction gear output) makes “L” revolutions when the motor (reduction gear input) makes “M” revolutions. The nominal gear ratio may not be a precise value. Determine the exact ratio from the number of gear teeth.

Incorrect positioning will result unless a precise gear ratio is specified.

5. Set parameters.

Cn-23: Command units per machine revolution (the value calculated in 3.)

Cn-24: Speed of motor shaft rotation ($4 \times$ “M” observed in 4.)

Cn-25: Speed of load shaft rotation (“L” observed in 4.)

Check that the following conditions are met:

$$0.01 \leq \text{Electronic gear ratio } \left(\frac{B}{A}\right) = \frac{\text{Cn-11 (number of encoder pulses)} \times \text{Cn-24}}{\text{Cn-23} \times \text{Cn-25}} \leq 100$$

If the electronic gear ratio is outside this range, the SERVOPACK will not work properly.

Modify the machine configuration (gear ratio, ball screw lead, number of motor encoder pulses) or command unit so that the above conditions are met.

SERVOPACK positioning accuracy will be the number of encoder pulses (Cn-11) \times 4 per motor revolution. When the electronic gear ratio $\left(\frac{B}{A}\right)$ is less than 1, the minimum command unit is smaller than the SERVOPACK positioning accuracy. In other words, the actual positioning accuracy is less than the minimum command unit.

Note: Acceleration/deceleration and low speed feed may not operate smoothly even if the setting of the electronic gear ratio is within the range of $0.01 \leq (B/A) \leq 100$.

However, the positioning is completed correctly.

- Increasing Speed Regulation of the Low Speed Feed

When the electronic gear ratio (B/A) is between 30 and 100, motor rotates as a hunching and then the speed change increases at low speed feed (100 min^{-1} or less for encoder pulse 2048 per revolution and 30 min^{-1} or less for 4096 per revolution).

This electronic gear ratio may cause noise or instability after the overtravel stops. Set as zero clamps to occur after the overtravel.

When using low speed feed operation, set the electronic gear ratio less than 30 as the machine configuration.

- Timestep Acceleration/deceleration

The acceleration/deceleration speed may changes as the shape of stairs if the inner calculative resolution reaches its limit and acceleration/deceleration slows. So, the motor does not rotate immediately and requires a short time before starting to rotate.

Recommended Range of the Electronic Gear Ratio

Electronic Gear Ratio (B/A)	Linear Acceleration/Deceleration Time
Less than 100	Enable to set from 8 ms to 5000 ms
Less than 73	Enable to set from 8 ms to 7500 ms
Less than 53	Enable to set from 8 ms to 10000 ms
Less than 37	Enable to set from 8 ms to 20000 ms
Less than 30	Enable to set from 8 ms to 30000 ms
Less than 20	Enable to set from 8 ms to 60000 ms (maximum value)

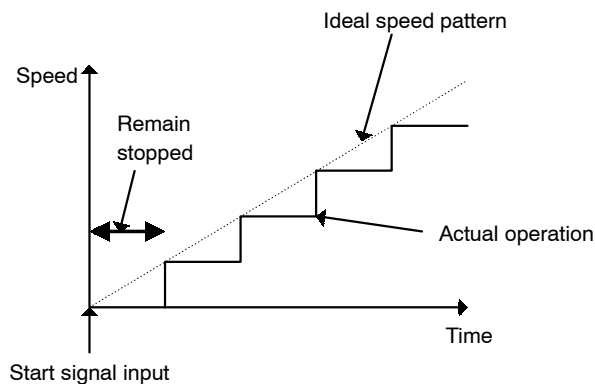

Examples of Setting an Electronic Gear Ratio

The following examples show electronic gear ratio settings for different load mechanisms.

Ball Screw

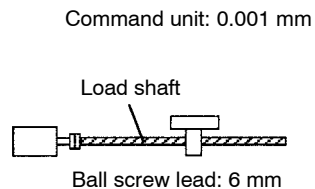

$$\text{Travel distance per revolution of load shaft (Cn-23)} = \frac{6 \text{ mm}}{0.001 \text{ mm}} = 6000$$

$$\text{Motor shaft rotation speed (Cn-24)} = 1 \times 4 = 4$$

$$\text{Load shaft rotation speed (Cn-25)} = 1$$

Disc Table

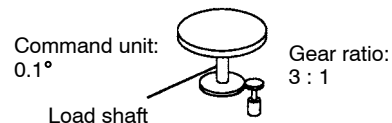

$$\text{Travel distance per revolution of load shaft (Cn-23)} = \frac{360^\circ}{0.1^\circ} = 3600$$

$$\text{Motor shaft rotation speed (Cn-24)} = 3 \times 4 = 12$$

$$\text{Load shaft rotation speed (Cn-25)} = 1$$

Belt & Pulley

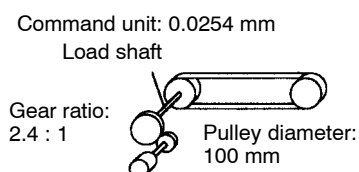

$$\text{Travel distance per revolution of load shaft (Cn-23)} = \frac{3.14 \times 100 \text{ mm}}{0.0254 \text{ mm}} = 12362$$

$$\text{Motor shaft rotation speed (Cn-24)} = 12 \times 4 = 48$$

$$\text{Load shaft rotation speed (Cn-25)} = 5$$

3.1.6 Setting the Acceleration/Deceleration Type and Rate

Exponential acceleration/deceleration or other types of acceleration/deceleration (linear or S-shaped acceleration/deceleration) can be selected for each operation mode in the SERVO-PACK.

The selection is made using bit 0 in memory switch Cn-39.

Cn-39 Bit 0	Acceleration/Deceleration Type	Factory Setting: 0
--------------------	--------------------------------	--------------------

Setting	Meaning
0	Do not use an acceleration/deceleration type.
1	Use an acceleration/deceleration type.

Set bit 0 of Cn-39 to 0 to select 1-step linear acceleration/deceleration for all operation modes.

Set bit 0 of Cn-39 to 1 to enable the settings in bits 1, 2, 8, A, C, and E of Cn-39.

Cn-39 Bit 8	Acceleration/Deceleration Type for Automatic Operation Mode	Factory Setting: 0
--------------------	---	--------------------

Cn-39 Bit A	Acceleration/Deceleration Type for Manual Operation Mode	Factory Setting: 0
--------------------	--	--------------------

Cn-39 Bit C	Acceleration/Deceleration Type for Pulse Operation Mode	Factory Setting: 0
--------------------	---	--------------------

Cn-39 Bit E	Acceleration/Deceleration Type for Zero Point Return Mode	Factory Setting: 0
--------------------	---	--------------------

Setting	Meaning
0	Linear or S-shaped acceleration/deceleration
1	Exponential acceleration/deceleration

Set the acceleration/deceleration type for each operation mode.

If the type is set to 0, the acceleration/deceleration type for that operation mode will be based on the settings in bits 1 and 2 of Cn-39.

If the type is set to 1, the acceleration/deceleration type for that operation mode will be exponential acceleration/deceleration.

The following settings in bits 1 and 2 of Cn-39 are enabled only when bit 8, A, C, or E of Cn-39 in each operation mode is set to 0.

Cn-39 Bit 1	1-step/2-step Linear Acceleration/Deceleration Selection	Factory Setting: 0
--------------------	--	--------------------

Setting	Meaning
0	1-step acceleration/deceleration
1	2-step acceleration/deceleration

This setting is enabled only when bit 0 of Cn-39 is set to 1 and bit 2 of the same memory switch is set to 0.

If bit 1 is set to 0, 1-step linear acceleration/deceleration will be used.

If bit 1 is set to 1, 2-step linear acceleration/deceleration will be used.

Cn-39 Bit 2	S-shaped Acceleration/Deceleration	Factory Setting: 0
--------------------	------------------------------------	--------------------

Setting	Meaning
0	Not used.
1	Used.

This setting is enabled only when bit 0 of Cn-39 is set to 1.

When bit 2 is set to 0, the acceleration/deceleration will be linear according to the setting in bit 1 of Cn-39.

When bit 2 is set to 1, the acceleration/deceleration will be S-shaped.

The acceleration/deceleration rate for each type of acceleration/deceleration is set using the following parameters:

■ For 1-step Linear Acceleration and Deceleration

Cn-1F	First Feed Speed	Unit: $\times 1000$ command units/min	Setting Range: 0 to 240000	Factory Setting: 500
--------------	------------------	---	-------------------------------	-------------------------

Cn-3A	Linear Acceleration/Deceleration Time 1	Unit: ms	Setting Range: 8 to 60000	Factory Setting: 100
--------------	---	----------	------------------------------	-------------------------

The speed is shown in the following diagram:

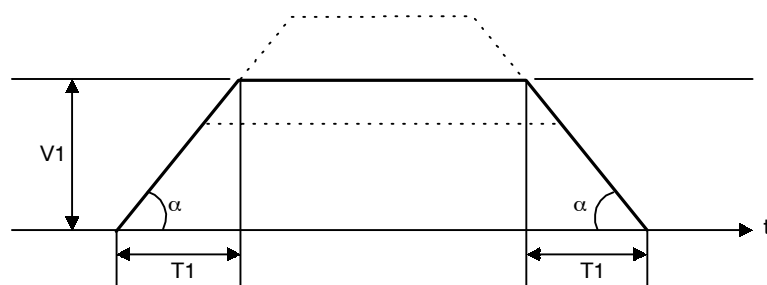

V1: The feed speed set in memory switch Cn-1F.

T1: Linear acceleration/deceleration time set in memory switch Cn-3A.

The acceleration/deceleration rate α is calculated as $V1/T1$.

■ For 2-step Linear Acceleration and Deceleration

Cn-1F	First Feed Speed	Unit: $\times 1000$ command units/min	Setting Range: 0 to 240000	Factory Setting: 500
Cn-3A	Linear Acceleration/Deceleration Time 1	Unit: ms	Setting Range: 8 to 60000	Factory Setting: 100
Cn-3B	Linear Acceleration/Deceleration Time 2	Unit: ms	Setting Range: 8 to 60000	Factory Setting: 100
Cn-3C	2-step Linear Acceleration/Deceleration Acceleration Switching Speed	Unit: $\times 1000$ command units/min	Setting Range: 0 to 240000	Factory Setting: 500

The speeds are shown in the following diagram.

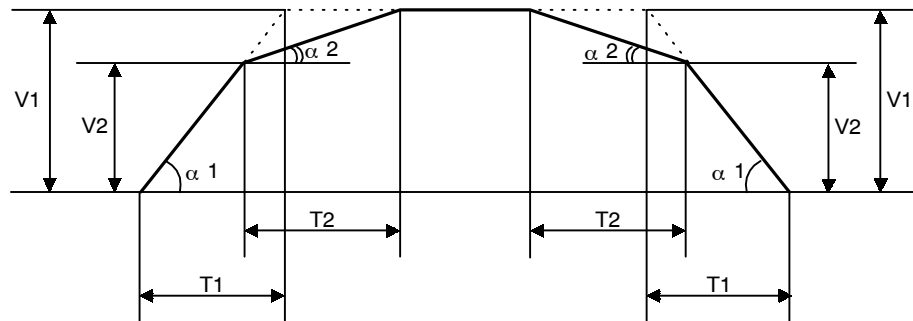

V1: Feed speed set in memory switch Cn-1F.

V2: Switching speed set in memory switch Cn-3C.

T1: Linear acceleration/deceleration time set in memory switch Cn-3A.

T2: Linear acceleration/deceleration time set in memory switch Cn-3B.

Acceleration/deceleration α is calculated as $V1/T1$, $\alpha 2$ as $(V1 - V2)/T2$, and these remain constant even if the feed speed changes.

■ For S-shaped Acceleration and Deceleration

Cn-1F	First Feed Speed	Unit: $\times 1000$ command units/min	Setting Range: 0 to 240000	Factory Setting: 500
Cn-3A	Linear Acceleration/Deceleration Time 1	Unit:ms	Setting Range: 8 to 60000	Factory Setting: 100

Cn-19	S-shaped Acceleration/Deceleration Time	Unit:ms	Setting Range: 0 to 1000	Factory Setting: 0
--------------	---	---------	--------------------------	--------------------

The speeds are shown in the following diagram.

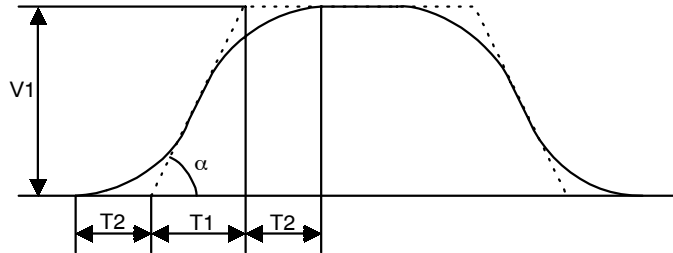

V1: Feed speed set in memory switch Cn-1F.

T1: Linear acceleration/deceleration time set in memory switch Cn-3A.

T2: S-shaped acceleration/deceleration time set in memory switch Cn-19.

Acceleration/deceleration rate α is calculated as $V1/T1$.

3

■ Exponential Acceleration and Deceleration

Cn-3D	Exponential Acceleration/Deceleration Constants	Unit: ms	Setting Range: 8 to 1000	Factory Setting: 100
--------------	---	----------	--------------------------	----------------------

Cn-3E	Exponential Acceleration/Deceleration Bias Speed	Unit: $\times 1000$ command units/min	Setting Range: 0 to 240000	Factory Setting: 0
--------------	--	---------------------------------------	----------------------------	--------------------

The following diagram shows the speeds.

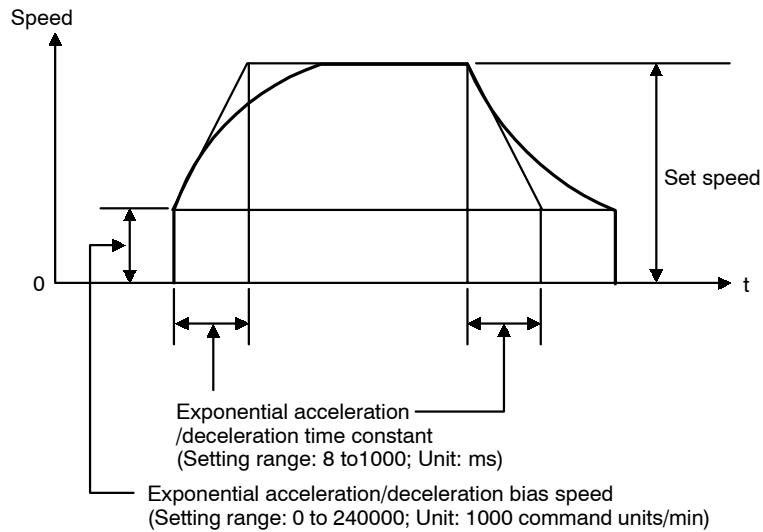

3.1.7 Setting Speed Limits

Set speed limits for the SERVOPACK if the maximum rotating speed of the motor is higher than the allowable rotating speed for the machine.

Set the following parameters when using speed limits.

Cn-03	Speed Limit	Unit: $\times 1000$ command units/min	Setting Range: 1 to 240000	Factory Setting: 10000
--------------	-------------	---	-------------------------------	---------------------------

3.1.8 Setting Torque Limits

The SGDB SERVOPACK can provide the following torque controls:

- Level 1: To restrict the maximum output torque to protect the machine or workpiece (internal torque limit)
- Level 2: To restrict torque after the motor moves the machine to a specified position (external torque limit)

■ How to Set Level 1: Internal Torque Limit

The maximum torque is restricted to the values set in the following parameters.

Cn-10	Torque Limit	Unit: %	Setting Range: 0 to 800	Factory Setting: 800
--------------	--------------	---------	----------------------------	-------------------------

The same maximum torque value is set for both forward and reverse rotation.

Set this value to limit the torque according to machine conditions.

The setting unit is a percentage of the rated torque.

The torque limit is always applied.

If a value higher than the maximum torque is set, the maximum torque value is used.

A signal can be output to indicate that the torque is being restricted. Refer to 2. *Using /CLT Signal* under *How to Set Level 2: External Torque Limit*.

Example of Use: Machine Protection

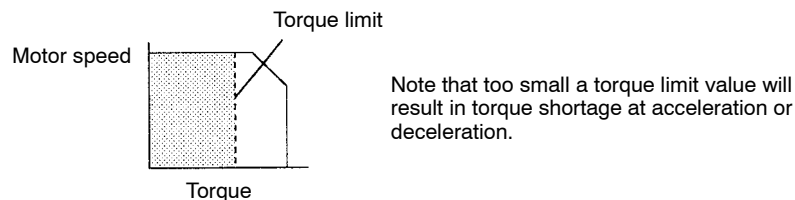

■ How to Set Level 2: External Torque Limit

First, use a contact input signal to make the torque (current) limit value set in the parameter valid. Torque limit can be set separately for forward and reverse rotation.

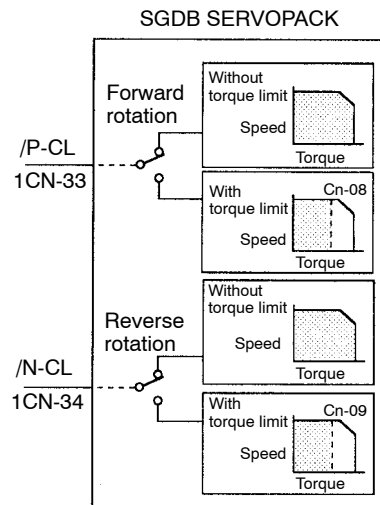

P-CL	ON: 1CN-33 is at low level.	Torque limit is applied to forward rotation.	Limit value: Cn-08
	OFF: 1CN-33 is at high level.	Torque limit is applied to forward rotation.	–
N-CL	ON: 1CN-34 is at low level.	Torque limit is applied to reverse rotation.	Limit value: Cn-09
	OFF: 1CN-34 is at high level.	Torque limit is applied to reverse rotation.	–

A signal can be output to indicate that the torque is being limited. Refer to 2. *Using /CLT Signal* later in this section.

Examples of Use:

- Forced Stopping

Cn-08	Forward External Torque Limit	Unit: %	Setting Range: 0 to 800	Factory Setting: 800
Cn-09	Reverse External Torque Limit	Unit: %	Setting Range: 0 to 800	Factory Setting: 800

Sets a torque limit value when torque is restricted by external contact input.

When /P-CL (1CN-33) is input	Torque limit set in memory switch Cn-08 is applied during forward rotation.
When /N-CL (1CN-34) is input	Torque limit set in memory switch Cn-09 is applied during reverse rotation.

1. Using /P-CL and /N-CL Signals

This section describes how to use input signals /P-CL and /N-CL as torque limit input signals.

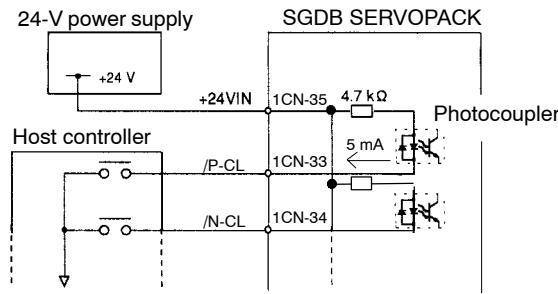

→ Input /P-CL 1CN-33	Forward External Torque Limit Input
→ Input /N-CL 1CN-34	Reverse External Torque Limit Input

These signals are for forward and reverse external torque (current) limit input.

This function is useful in forced stopping.

A signal can be output to indicate that the torque is being limited. Refer to 2. *Using /CLT Signal* below.

2. Using /CLT Signal

This section describes how to use contact output /CLT signal for torque limit detection output.

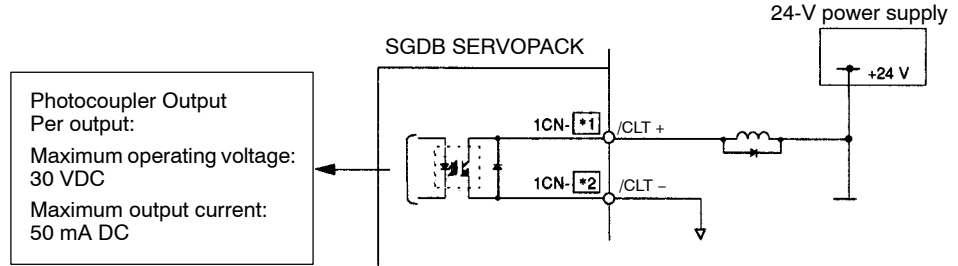

→ Output /CLT 1CN-*1	Torque Limit Detection Output
-----------------------------	-------------------------------

This signal indicates whether motor output torque (current) is being restricted.

ON status:	The circuit between 1CN-*1 and 1CN-*2 is closed. 1CN-*1 is at low level.	Motor output torque is being restricted. (Internal torque command is greater than the preset value.)
OFF status:	The circuit between 1CN-*1 and 1CN-*2 is open. 1CN-*1 is at high level.	Motor output torque is not being restricted. (Internal torque command is equal to or below the preset value.)

Set the following parameter to select the output pin for the signal.

Cn-2D	Output Signal Selection	Setting Range: 111 to 666	Factory Setting: 214
--------------	-------------------------	---------------------------	----------------------

Select which function signal will be output as the 1CN output signal.

1's digit	Selects 1CN-16, 17 (/BK) functions
10's digit	Selects 1CN-18, 19 (/TGON) functions
100's digit	Selects 1CN-20, 21 (/S-RDY) functions

Setting	Function	Reference Section
1	/TGON	3.2.13
2	/S-RDY	3.2.12
3	/CLT	3.1.8
4	/BK	3.14.2
5	Overload warning	3.2.14
6	Overload alarm	3.2.14

Example: The torque limit signal (/CLT) will be output to 1CN-18 and 1CN-19.

Cn-2D = 3

3.1.9 Setting Stored Stroke Limits

The stored stroke limit function sets in a parameter the range that the moving part of the machine can travel. Commands will not be accepted, and the machine will be stopped at a preset position if this range is exceeded by manual or pulse operation. The machine will decelerate to stop at a specified rate.

Limit switches can be omitted if the stored stroke limit function is used.

■ Stored Stroke Limit Function

In finite mode (memory switch Cn-26 bit 1 = 0), operation is controlled so that the current position of the motor will not exceed the set limits. An error will be detected if the current position is not within the set limits after a positioning operation.

In infinite mode (memory switch Cn-26 bit 1 = 1), an error will not be detected even if the current position is not within the set limits after a positioning operation.

Set the following memory switch bit to use the stored stroke limit function:

Cn-32 Bit 4	Stored Stroke Limit	Factory Setting: 0
--------------------	---------------------	--------------------

Use the following settings to specify whether or not the stored stroke limit function is to be used:

Setting	Meaning
0	Do not use the stored stroke limit function. (Standard setting)
1	Use the stored stroke limit function.

Set the moveable range using the following parameters:

Cn-06	Forward Rotation Stored Stroke Limit	Unit: Command unit	Setting Range: -99999999 to +99999999	Factory Setting: +99999999
Cn-07	Reverse Rotation Stored Stroke Limit	Unit: Command unit	Setting Range: -99999999 to +99999999	Factory Setting: -99999999

IMPORTANT

When an incremental encoder and finite length mode are used, the stored stroke limit function is disabled from when the control power is turned ON until the zero point return operation is completed.

When an incremental encoder and finite length mode are used, the stored stroke limit function cannot be used for applications that do not perform the zero point return operation.

3

3.1.10 Setting Backlash Compensation

If there is backlash in the machine system, the backlash compensation function offsets the backlash when the direction of rotation is changed. Set the backlash offset in the following parameter:

Cn-0D	Backlash Offset	Unit: PG pulses (× 4)	Setting Range: -30000 to +30000	Factory Setting: 0
--------------	-----------------	-----------------------------	---------------------------------------	-----------------------

After positioning in the forward direction, the Cn-0D value will be added to the current position before positioning in the reverse direction.

After positioning in the reverse direction, the Cn-0D value will be subtracted from the current position before positioning in the forward direction.

3.2 Signals Common to All Modes

3.2.1 Servo ON Signal

This section describes how to wire and use contact input signal “servo ON (/S-ON).” Use this signal to turn the servomotor ON or OFF from the host controller.

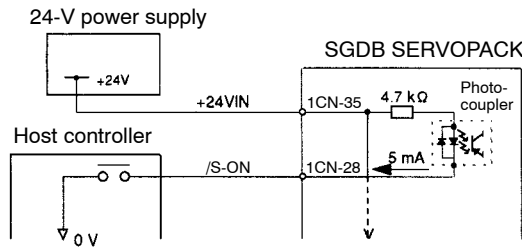

3

→ Input /S-ON 1CN-28 Servo ON

This signal is used to turn the motor ON or OFF.

ON: 1CN-28 is at low level	Turns the motor ON. This is normal operation state (called “servo ON state”).
OFF: 1CN-28 is at high level	Turns the motor OFF. This is inoperable state (called “servo OFF state”). The servo can be turned OFF during motor operation only when an emergency stop is required.

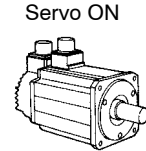

Motor is ON.
Motor is operated according to input signals.

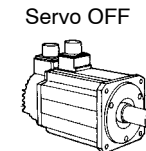

Motor is OFF.
Motor cannot run.

In the SERVOPACK, the same operation as the /S-ON signal can be performed using the SVON and SVOFF serial commands. If these serial commands are used, wiring for /S-ON input is not required.

Refer to Chapter 4 Using Serial Communications for information on serial commands.

IMPORTANT

Do not use the /S-ON signal or SVON or SVOFF commands to stop and start the motor. Always input commands to stop and start the motor.

If the /S-ON signal or SVON and SVOFF commands are not to be used, set the following memory switch bit to 1.

Cn-01 Bit 0	Use of /S-ON Signal and SVON, SVOFF Commands	Factory Setting: 0
--------------------	--	--------------------

This memory switch bit is used to enable or disable the servo ON input signal /S-ON (1CN-28). When external short-circuit wiring is omitted, set the memory switch bit to “1.”

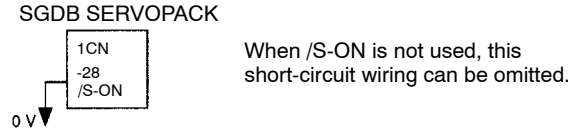

Setting	Meaning
0	Use servo ON signal /S-ON (1CN-28) or SVON and SVOFF commands. (For /S-ON signal: When 1CN-28 is open, servo is OFF. When 1CN-28 is closed, servo is ON.) (For serial commands: When SVOFF is issued, servo is OFF. When SVON is issued, servo is ON.)
1	Do not use servo ON signal /S-ON (1CN-28) or SVON and SVOFF commands. (The servo is always ON when the control power supply and the main circuit power supply are turned ON. This has the same effect as shorting 1CN-28 to 0 V.)

3.2.2 Pause Inputs

This section describes how to wire and use the STOP contact input signal. This signal is used to pause operation from the host controller.

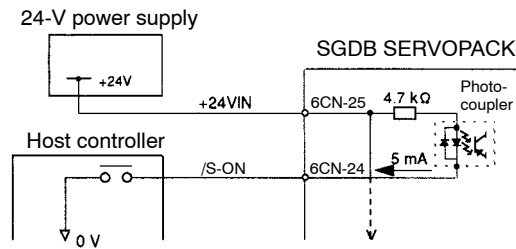

→ **Input STOP 6CN-24** Pause

The STOP signal is the pause command input signal in automatic operation and zero point return modes. If this signal is input during operation, the rising edge of the signal will be detected and the motor will be stopped at the deceleration rate set in the parameter. The STOP signal requires a pulse width of 8 ms or greater.

ON: 6CN-24 is at low level	The motor runs in automatic operation and zero point return modes.
OFF: 6CN-24 is at high level	The motor is stopped in automatic operation and zero point return modes.

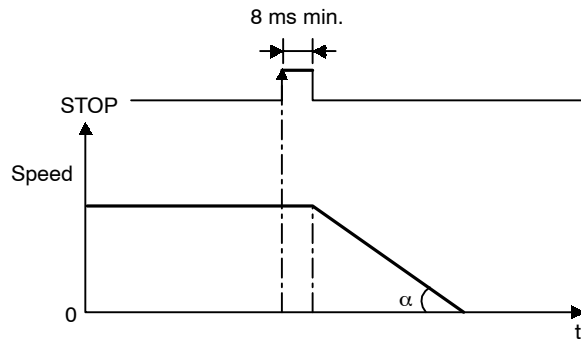

The following memory switch bit can be set to allow the feed hold function to be used with the STOP signal.

Cn-33 Bit 1	Residual Data after STOP Signal	Factory Setting: 0
--------------------	---------------------------------	--------------------

3

Setting	Meaning
0	Retains data (feed hold)
1	Discards data (no feed hold)

The feed hold function (positioning based on residual data) restarts the machine using the target position and feed speed specified by the previous command values (before the machine has been stopped) if the machine has been stopped using the STOP signal before positioning is completed and the start operation signal /AST is then input. If bit 2 of Cn-33 is set to 0, the feed hold function will be enabled. If it is set to 1, after the machine stops, the machine will be restarted using the target position and feed speed specified when the start operation signal /AST is input.

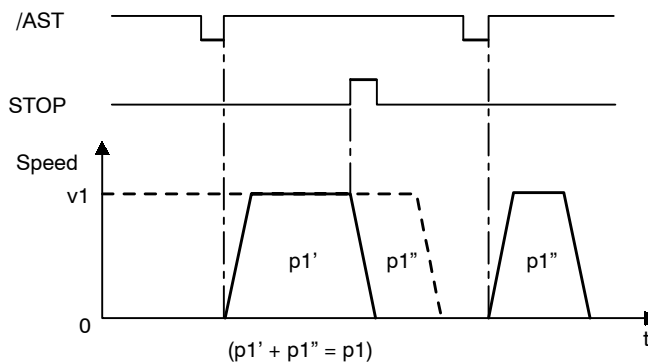
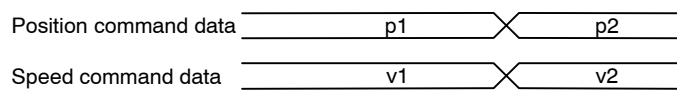

If the /AST signal is input when the STOP signal is at high level (open), the feed hold function will be performed.

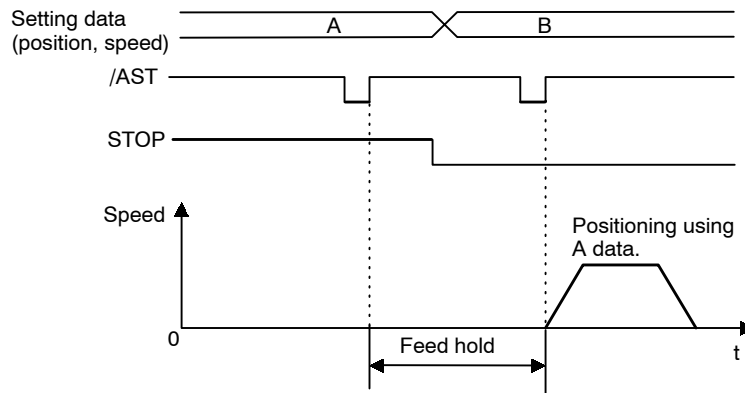

The following diagram shows an operation example when the STOP signal is used.

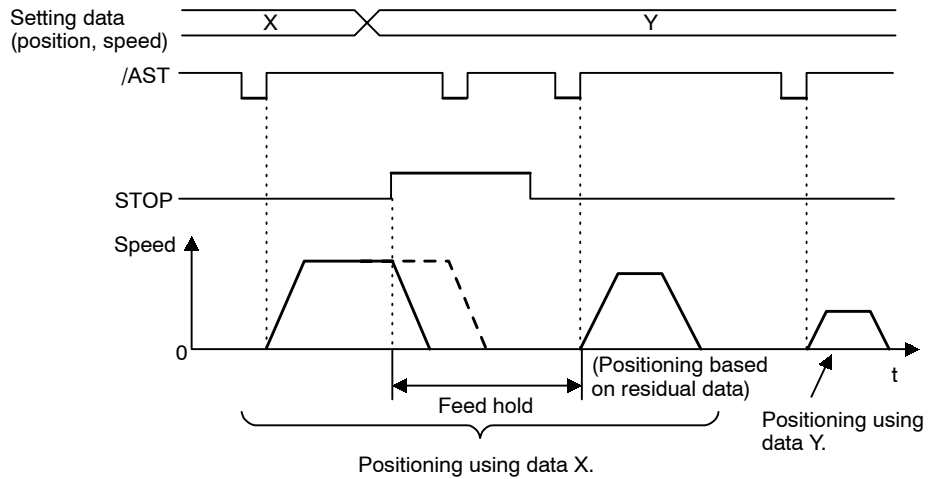

The feed hold is released (positioning based on residual data cleared) under the following conditions:

- When the STOP signal is at low level (closed), the /AST signal has been input, and the positioning based on residual data has been completed.
- When the operation mode has been switched, for example, from automatic operation to manual operation mode.
- When the servo has been turned OFF.

Set the following memory switch bit to 1 when not using the STOP signal.

Cn-33 Bit 0	STOP Signal Used/Not Used	Factory Setting: 0
--------------------	---------------------------	--------------------

Set whether or not the STOP signal (6CN-24) is to be used. Set this bit to 1 if external wiring is omitted.

SGDB SERVOPACK



Short circuit wiring can be omitted if the STOP signal is not used.

Setting	Meaning
0	Use the STOP signal (6CN-24). (When 6CN-24 is open, servo is stopped. When 6CN-24 is closed, servo operates normally.)
1	Do not use the STOP signal (6CN-24). (Normal operation status. This has the same effect as shorting 6CN-24 to 0 V.)

If the STOP signal is left unconnected (open), the servo will always be stopped and cannot operate in automatic operation or zero point return mode. If the STOP signal is not used, short circuit to 0 V or set bit 0 of Cn-33 to 1.

IMPORTANT

The STOP signal is not enabled in manual operation and pulse operation modes.

3.2.3 Overtravel Limit Function

The overtravel limit function forces the moving part of the machine to stop when it exceeds the movable range.

■ Using the Overtravel Limit Function

To use the overtravel limit function, connect the following overtravel limit switch input signals to the corresponding 1CN connector pins of the SERVOPACK.

→ Input P-OT 1CN-30	Forward Rotation Prohibited (Forward Overtravel)
→ Input N-OT 1CN-31	Reverse Rotation Prohibited (Reverse Overtravel)

Note: P-OT and N-OT will still prohibit forward rotation and reverse rotation, respectively, even if the motor rotation direction is changed using the method outlined in 3.1.3 *Direction of Motor Rotation*.

When using linear drive, connect a limit switch or set and use a stored stroke limit switch as explained in 3.1.9 *Setting Stored Stroke Limits* to avoid machine damage.

IMPORTANT

There is up to 1-ms delay from when the SERVOPACK detects the P-OT or N-OT signal until braking is applied, and there is further braking time before the machine stops. Consider these delays when setting limit switches and set the overtravel limits inside the motion limit for the machine.

P-OT and N-OT functions can be reversed using the settings in bit 8 of Cn-33.

Cn-33 Bit 8	Overtravel Signal Switching	Factory Setting: 0
--------------------	-----------------------------	--------------------

Select the OT signal function using the following settings:

Setting	Meaning
0	Uses the P-OT input signal (1CN-30) for prohibiting forward rotation. (Normal setting.) Uses the N-OT input signal (1CN-31) for prohibiting reverse rotation.
1	Uses the P-OT input signal (1CN-30) for prohibiting reverse rotation. (Normal setting.) Uses the N-OT input signal (1CN-31) for prohibiting forward rotation.

■ Switching Use of Input Signals

Use the following memory switch bits to specify whether input signals for overtravel are to be used.

Cn-01 Bit 2	Use of Forward Rotation Prohibit Input Signal	Factory Setting: 0
Cn-01 Bit 3	Use of Reverse Rotation Prohibit Input Signal	Factory Setting: 0

SGDB SERVOPACK

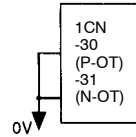

The short-circuit wiring shown in the figure can be omitted when P-OT and N-OT are not used.

3

Parameter	Setting	Meaning
Cn-01 Bit 2	0 (Factory setting)	Use forward rotation prohibit input signal. (When 1CN-30 open, forward rotation prohibited. Forward rotation permitted at 0 V.)
	1	Do not use forward rotation prohibit input signal. (Forward rotation always permitted. This has the same effect as short-circuiting 1CN-30 to 0 V.)
Cn-01 Bit 3	0 (Factory setting)	Use reverse rotation prohibit input signal. (When 1CN-31 open, reverse rotation prohibited. Reverse rotation permitted at 0 V.)
	1	Do not use reverse rotation prohibit input signal. (Reverse rotation always permitted. This has the same effect as short-circuiting 1CN-31 to 0 V.)

Motor Stop Method at Overtravel

If the P-OT and N-OT input signals are used, set the following parameters to specify how to stop the motor.

Specify how to stop the motor when either of the below signals is input.

- Inputs signal for inhibit forward rotation.
- Inputs signal for inhibit reverse rotation.

Cn-01 Bit 8	How to Stop Motor at Overtravel	Factory Setting: 0
Cn-01 Bit 9	Operation to be Performed when Motor Stops after Overtravel	Factory Setting: 0

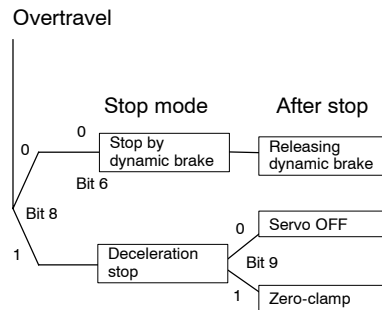

Parameter	Setting	Meaning
Cn-01 Bit 8	0	Stops the motor in the same way as when the servo is turned OFF. The motor is stopped by dynamic brake or coasts to a stop. Either of these stop modes is selected by setting bit 6 of Cn-01.
	1	Decelerates to stop at the maximum torque of the motor used.

If deceleration stop mode is selected, specify the operation to be done after the motor stops.

Parameter	Setting	Meaning
Cn-01 Bit 9	0	Turns the servo OFF when the motor stops in deceleration stop mode.
	1	Causes the motor to enter zero-clamp status after it stops in deceleration stop mode.

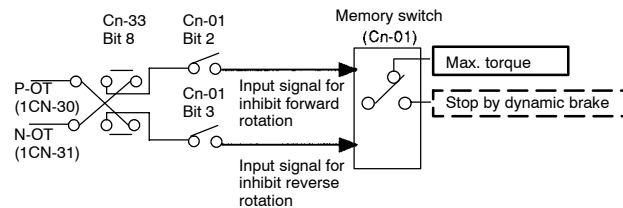

Motor Stop Method at Servo OFF

The SERVOPACK enters servo OFF status when:

- Servo ON input signal (/S-ON, 1CN-28) is turned OFF.
- Servo alarm arises.
- Power is turned OFF.

Specify how to stop the motor when one of the above events occurs during operation.

Cn-01 Bit 6	How to Stop Motor at Servo OFF	Factory Setting: 0	–
Cn-01 Bit 7	Operation to Be Performed when Motor Stops after Servo OFF	Factory Setting: 1	Invalid for 2.0 kW or more

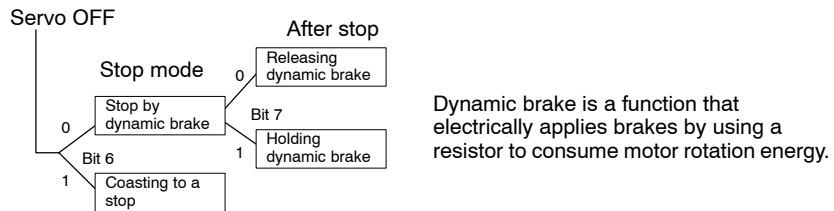

Parameter	Setting	Meaning
Cn-01 Bit 6	0 (Factory setting)	Stops the motor by dynamic brake.
	1	Causes the motor to coast to a stop. The motor power is OFF and stops due to machine friction.

If dynamic brake stop mode is selected, specify the operation to be performed when the motor stops.

Parameter	Setting	Meaning
Cn-01 Bit 7	0	Releases dynamic brake after the motor stops.
	1 (Factory setting)	Does not release dynamic brake even after the motor stops.

Note: For SERVOPACKs of 2.0 kW or more, bit 7 of Cn-01 can be set to 0 only.

3

3.2.4 Operation Mode Selection

This section describes how to wire and use three contact input signals for operation mode selection: /ZRN, /MAN, and /PULS. These signals are used when selecting the operation mode from the host controller.

→ Input /ZRN 6CN-13	Zero Point Return Mode Selection Input
→ Input /MAN 6CN-14	Manual Operation Mode Selection Input
→ Input /PULS 6CN-15	Pulse Operation Mode Selection Input

The input levels for each signal and the selected operation modes are shown in the following table.

Operation Mode	Operation Mode Setting Signal			General Operation
	/MAN	/PULS	/ZRN	
Automatic	H	H	H	Sets position data and performs positioning according to the /AST signal.
Manual	L	H	H	Performs constant speed operation using manual operation signals /MCCW and /MCW.
Pulse	H	L	H	Performs positioning using the pulse train commands.
Zero Point Return	H	H	L	Performs the zero point return operation set in the parameter according to the /AST signal.
Don't Use	H	L	L	With these settings, a mode error will occur and an /ERR signal will be output. Operation will not be possible.
	L	H	L	
	L	L	H	
	L	L	L	

- Note: 1. If the operation mode is switched during motor operation, the motor will decelerate to a stop at the set deceleration rate. The residual command data will not be kept, i.e. there is no feed hold.
2. An interval of at least 50 ms is required between switching operation modes and starting operation (/AST, /MCCW, /MCW).

3.2.5 Operation Mode Display Output

This section describes how to wire and use two photocoupler output signals for operation mode display outputs using /AUT-LT and /MAN-LT. These output signals show when operation is possible in automatic or manual mode.

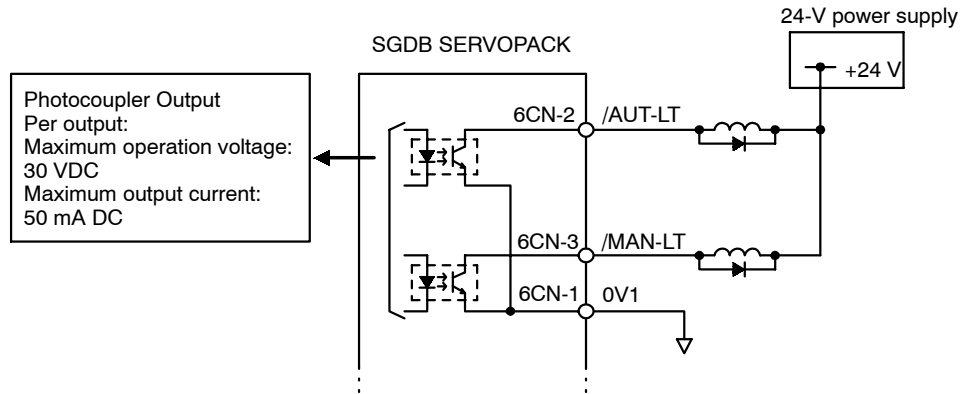

Output → /AUT-LT 6CN-2

Automatic Operation Mode Display Output

Output → /MAN-LT 6CN-3

Manual Operation Mode Display Output

/AUT-LT	ON status	The circuit between 6CN-1 and 6CN-2 is closed. 6CN-2 is at low level.	The motor is turned ON (servo ON) and automatic operation mode is selected.
	OFF status	The circuit between 6CN-1 and 6CN-2 is open. 6CN-2 is at high level.	The motor is turned OFF (servo OFF) or automatic operation mode is not selected.
/MAN-LT	ON status	The circuit between 6CN-1 and 6CN-3 is closed. 6CN-3 is at low level.	The motor is turned ON (servo ON) and manual operation mode is selected.
	OFF status	The circuit between 6CN-1 and 6CN-3 is open. 6CN-3 is at high level.	The motor is turned OFF (servo OFF) or manual operation mode is not selected.

3.2.6 Operation Start Input

This section describes how to wire and use a contact input signal to start operation with /AST. This signal is used when starting operation in automatic operation and zero point return modes.

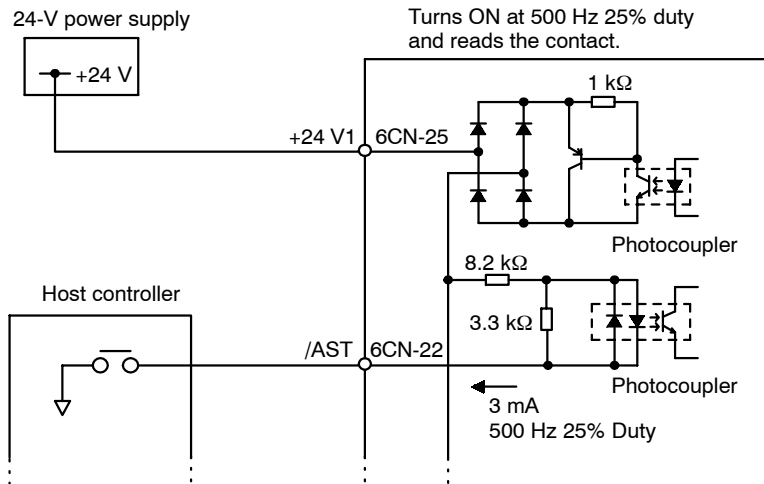

3

Input → /AST 6CN-22	Operation Start
----------------------------	------------------------

The memory switch setting changes the effective logic.

The effective logic for /AST signals based on these memory switch combinations is shown in the following table.

In the following table, open signals are represented by high level and closed signals are represented by low level.

Cn-33 Bit B	0	1	0	1
Cn-33 Bit C	0	0	1	1
Cn-33 Bit D	0	0	0	0
Speed Command	[Pulse waveform]			
/COIN Output Logic	H	[High level]	[High level]	[High level]
	L	[Low level]	[Low level]	[Low level]
/AST Input Logic	H	[High level]	[Low level]	[Low level]
	L	[Low level]	[High level]	[High level]

Note: If bits C and D of Cn-33 are set to 0, and the /AST signal is ON, /COIN signal is always H.

Cn-33 Bit B	0	1	0	1
Cn-33 Bit C	0	0	1	1
Cn-33 Bit D	1	1	1	1
Speed Command				
/COIN Output Logic				
/AST Input Logic				

These signals require a minimum pulse width of 8 ms.

/AST signals are enabled under the following conditions and motor operation will start:

- The motor is ON (servo ON).
- Automatic operation mode or zero point return mode has been selected.
- The STOP signal is closed (at low level), or disabled using the memory switch bit.
- Position command is normal.
- Speed command is normal.

If either the position command or speed command is not normal, a command error output /ERR will be generated. Refer to 3.2.9 *Command Error Outputs*.

The /AST signal will be ignored in the following cases:

- When the motor is OFF (servo OFF).
- When the motor is operating.
- When not in automatic or zero point return mode.

3

3.2.7 Reset and Alarm Reset Input

This section describes how to wire and use two contact input signals for the reset input signal /RST and alarm reset input signal /ALMRST. These signals are used for the initial reset of the SERVOPACK and to reset the servo alarm.

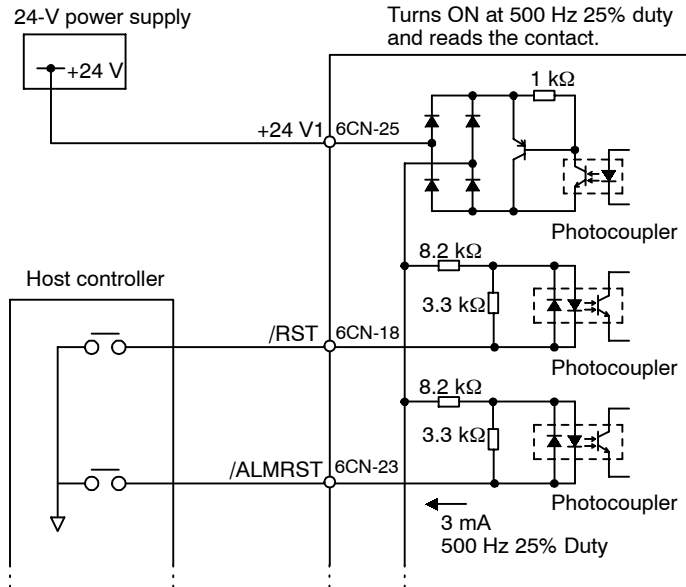

Input → /RST 6CN-18

Reset

The /RST input signal resets the SERVOPACK. The operation is the same as turning the control power supply OFF and ON again. This signal is used to change offline parameter or memory switch settings. The RES serial command performs the same operation.

When the SERVOPACK is initially reset, the alarm signal ALM will turn OFF after approximately 2 seconds. After the ALM signal turns ON again, the servo starts normal operation.

Input → /ALMRST 6CN-23

Alarm Reset

The /ALMRST input signal resets a servo alarm when it occurs. The alarm can also be reset using the serial command ARES or from the Digital Operator. The alarm is also reset when the control power supply is turned OFF and ON again.

When an alarm is generated, reset the alarm only after eliminating the cause of the alarm. Refer to 7.2.1 *Troubleshooting Problems with Alarm Display*.

Both /RST and /ALMRST signals are enabled by closing the signal (low level) for 8 ms minimum.

3.2.8 Servo Alarm Output

This section describes how to wire and use a photocoupler output signal for alarm output signal ALM.

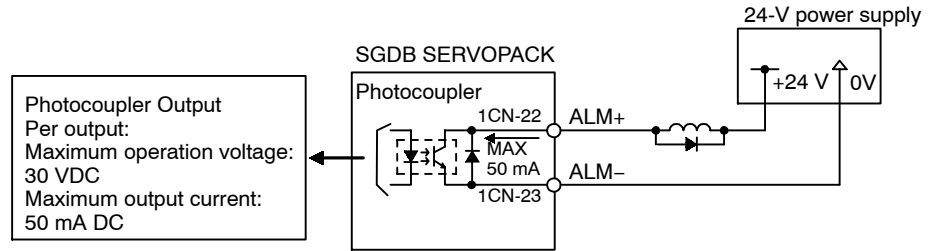

Prepare a separate external 24-V power supply. There is no power supply terminal for external output from the SGDB SERVOPACK.

The ALM signal is handled as follows:

Output → ALM+ 1CN-22	Servo Alarm Output
Output → ALM- 1CN-23	Signal Ground for Servo Alarm Output

This signal remains ON when SGDB SERVOPACK is operating normally, and turns OFF when an alarm is detected.

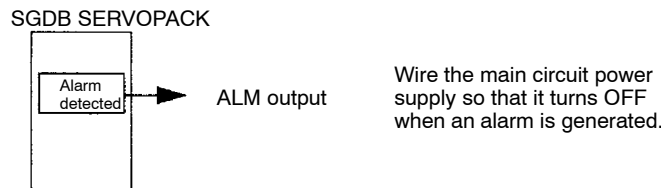

Configure the external circuit so that ALM signal turns OFF the main circuit power supply to the SGDB SERVOPACK.

ON status:	The circuit between 1CN-22 and 1CN-23 is closed. 1CN-22 is at low level.	Normal
OFF status:	The circuit between 1CN-22 and 1CN-23 is open. 1CN-22 is at high level.	Alarm

Alarm code output signals /AL0, /AL1, /AL2, and /AL3 are used to indicate different types of alarms.

Refer to 3.2.10 Alarm Code Outputs for details on alarm codes.

3

3.2.9 Command Error Outputs

This section describes how to wire and use a photocoupler output signal for command error output signal /ERR. This signal is output when there is a command data or operation error caused by the contact signal or a command error in serial communications in fixed-length mode. The motor cannot be operated if this signal is output.

Output → /ERR 6CN-27

Command Errors

The command error output signal turns ON (circuit between 6CN-27 and 6CN-26 closed, 6CN-27 at low level) under the following conditions:

1. Mode Selection Input Errors

- When two or more operation mode selection input signals (/MAN, /PULS, /ZRN) turn ON while the motor is ON (servo ON).
Turn the motor OFF (servo OFF) or return the operation mode selection input signals to normal status to clear the error.
- When the line PG selection signal (/LPG) is input in pulse operation mode.
Turn OFF the line PG selection signal (/LPG) to clear the error.

2. Position Data Errors

- When non-BCD data (A to F) is specified and the operation start signal (/AST) is input although position data have been set in BCD.
- When station 0 is specified and the operation start signal (/AST) is input although absolute commands and no station 0 have been set in station number command mode.
Correct the position data and input the operation start signal (/AST) or temporarily switch the operation mode to other than automatic operation mode to clear the error.

3. Speed Data Errors

- When inputting speed data that exceeds the speed limit (maximum motor speed or parameter Cn-03 setting, whichever is smaller) and an operation start signal (/AST) is input.
Correct the speed data and input the operation start signal (/AST) or temporarily switch the operation mode to other than automatic operation mode to clear the error.

Note: For a manual operation (/MCCW or /MCW), the speed data is clamped with the maximum rotating speed so that a speed error does not occur.

4. Overtravel

- When the overtravel limit switch (P-OT or N-OT) is activated (including situations where the load is moved by an external force when the motor is OFF (servo OFF)).
Return the machine to a position where the overtravel limit switch is not activated to clear the error.

5. Stored Stroke Limit Switch Errors

- When position data is input as position data that exceeds the stored stroke limit switch setting and the operation start signal (/AST) is input in automatic operation mode.
Correct the position data and input the operation start signal (/AST) or temporarily switch the operation mode to other than automatic operation mode to clear the error.
- When the stored stroke limit switch position is reached during operation in manual or pulse operation modes and the motor stops.
- When the load is moved by an external force and reaches the stored stroke limit position when the motor is OFF (servo OFF).
Return the machine to within the stored stroke limit to clear the error.

6. Communications Errors

- Parity errors generated during serial communications in fixed length mode.
- Overrun errors generated during serial communications in fixed length mode.
- Framing errors generated during serial communications in fixed length mode.
The error will be cleared when the next normal data is received.

7. Command Errors

- Undefined command received during serial communications in fixed length mode.
The error will be cleared when the next normal data is received.

8. Number Errors

- When a command that requires arguments for serial communications in fixed length mode is received, but the argument is missing or exceeds the allowable setting range.
Example: In the parameter setting command PRMnn = mmmmmmmm, nn is missing or nn is outside the range $1 \leq nn \leq 3F$.
The error will be cleared when the next normal data is received.

9. Data Errors

- When a command that requires data for serial communications in fixed length mode is received, but the data is missing or exceeds the allowable setting range.
Example: In the parameter setting command PRMnn = mmmmmmmm, mmmmmmmm is missing or exceeds the setting range for each parameter.
The error will be cleared when the next normal data is received.

3.2.10 Alarm Code Outputs

This section describes how to wire and use photocoupler output signals for alarm code output signals /AL0, /AL1, /AL2, and /AL3.

These sequence output signals indicate the operation status of the SGDB SERVOPACK.

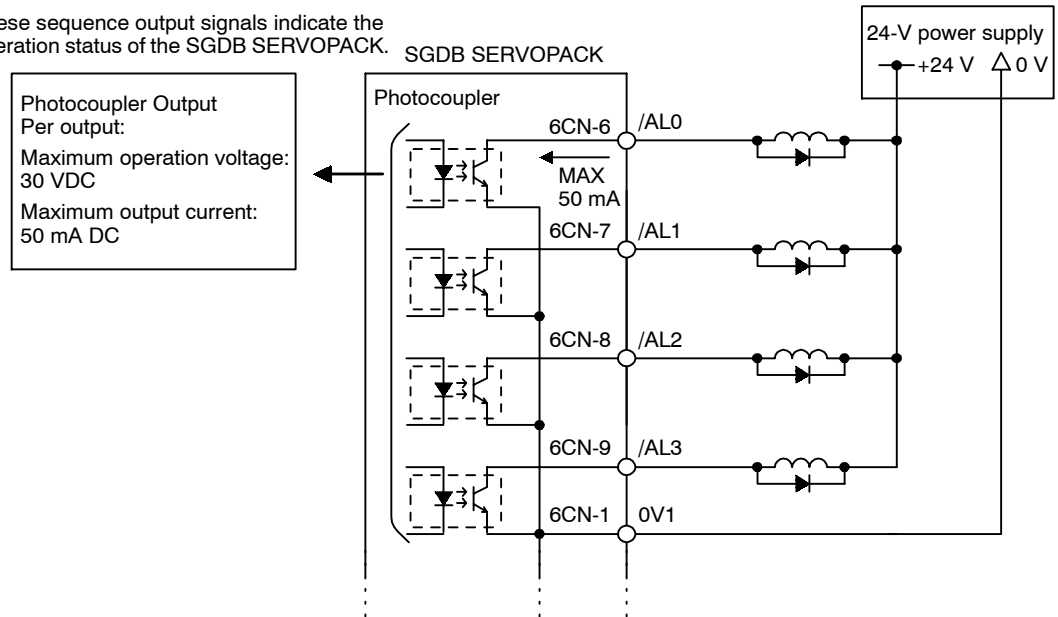

Prepare a separate external 24-V power supply. There is no power supply terminal for external output from the SGDB SERVOPACK.

Alarm code output signals /AL0, /AL1, /AL2, and /AL3 are handled as follows:

Output → /AL0 6CN-6	Alarm Code Output (1)
Output → /AL1 6CN-7	Alarm Code Output (2)
Output → /AL2 6CN-8	Alarm Code Output (3)
Output → /AL3 6CN-9	Alarm Code Output (4)

When an alarm is generated (ALM signal is at high level) or a command error has been generated (/ERR signal is at low level), an alarm code indicating the type of alarm or command error will be output. These alarm codes are used to display the alarm on the host controller.

The relationship between alarm display and the alarm code output outlined above is shown in the following table.

3.2.10 Alarm Code Outputs

Item	Alarm Display			ALM	/ERR	Alarm Code Output				Alarm Name			
	7-segment LED	Serial Data (Communications Mode)	Serial Data (Fixed-length Mode)			/AL3	/AL2	/AL1	/AL0				
Status	.	No serial transmission.	No serial transmission.	L	H	H	H	H	H	Motor ON	Command processing	Normal	
				L	L	L	H	L	H			Mode error	
				L	L	L	H	L	L			Position error	
				L	L	L	L	H	H			Speed error	
	-			L	H	H	H	H	H	Motor power supply interrupted (servo OFF)			
	P.	P-OT	POT	L	L	H	H	L	H	Forward rotation overtravel			
		P-LS	PLS	L	L	H	L	H	H	Forward rotation outside stored stroke limit			
	n.	N-OT	NOT	L	L	H	H	L	L	Reverse rotation overtravel			
		N-LS	NLS	L	L	H	L	H	L	Reverse rotation outside stored stroke limit			
	E.	Not detected	ERRE1	L	L	L	L	L	H	Communications error			
		ERR SN	ERRE2							Command error			
		ERR PN	ERRE3							Number error			
		ERR OV	ERRE4							Data error			
	Alarm	0.	A.00	ALM00	H	H	H	H	H	H	Absolute encoder data alarm		
A.02			ALM02	Parameter breakdown									
A.04			ALM04	Parameter setting alarm									
1.		A.10	ALM10	H	H	H	H	H	L	Overcurrent			
3.		A.30	ALM30	H	H	H	H	L	L	Regenerative alarm			
4.		A.40	ALM40	H	H	H	L	H	H	Main circuit voltage alarm			
5.		A.51	ALM51	H	H	H	L	H	L	Overspeed			
7.		A.71	ALM71	H	H	H	L	L	L	L	Overload (high load)		
		A.72	ALM72								Overload (low load)		
		A.7A	ALM7A								Heat sink overheat		
8.		A.80	ALM80	H	H	L	H	H	H	H	Encoder zero point alarm		
		A.81	ALM81								Absolute encoder backup alarm		
		A.82	ALM82								Absolute encoder checksum alarm		
		A.83	ALM83								Absolute encoder battery alarm		
		A.84	ALM84								Absolute encoder data alarm		
	A.85	ALM85	Absolute encoder overspeed										

3

Item	Alarm Display			ALM	/ERR	Alarm Code Output				Alarm Name
	7-segment LED	Serial Data (Communications Mode)	Serial Data (Fixed-length Mode)			/AL3	/AL2	/AL1	/AL0	
Alarm	C.	A.C1	ALMC1	H	H	L	L	H	H	Servo overrun alarm
		A.C2	ALMC2							Encoder phase error detection alarm
		A.C3	ALMC3							Encoder phases A and B disconnection
		A.C4	ALMC4							Encoder phase C disconnection
	b.	A.B0	ALMB0	H	H	L	H	L	L	Hardware alarm
	d.	A.D0	ALMD0	H	H	L	L	H	L	Position error pulse overflow
	F.	A.F1	ALMF1	H	H	L	L	L	L	Power line open phase detect
		A.F3	ALMF3							Power loss
=	Undefined	Undefined	H	Undefined				CPU alarm		

Note: H: Output transistor is ON
L: Output transistor is OFF

Refer to *Appendix D List of Alarm Displays*.

When the automatic operation mode is in station number command mode, the alarm code can be output as the higher-place digit of the current station number output. Refer to *3.4.3 Current Station Number Output and Station Number Read Selection Input*.

3.2.11 Positioning Complete and Positioning Proximity Signals

This section describes how to wire and use photocoupler input signals for the positioning complete output (/POS1) and positioning proximity output signals (/POS2). These signals indicate that the servomotor move is complete.

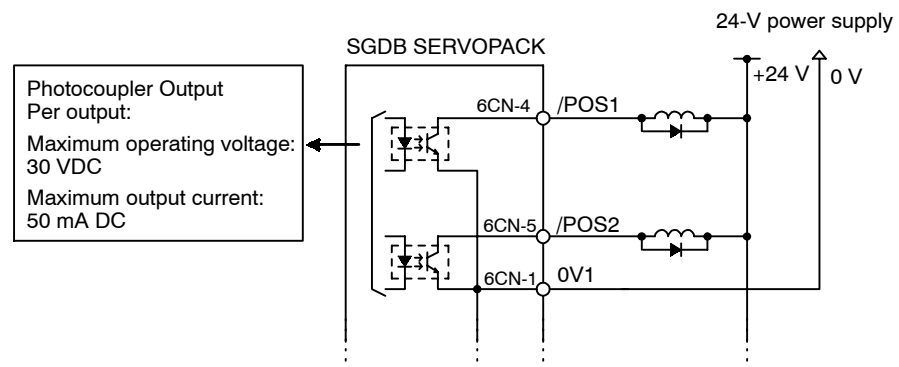

Output → /POS1 6CN-4

Positioning Complete Output (/COIN)

This output signal indicates that motor move is complete. The host controller uses this signal as an interlock to confirm that positioning is complete.

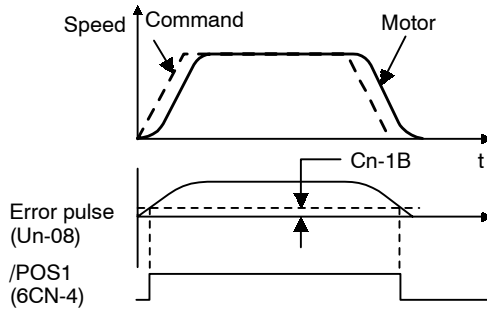

ON status	The circuit between 6CN-4 and 6CN-1 is closed. 6CN-4 is at low level.	The command distribution and positioning are complete (position error is below the preset value).
OFF status	The circuit between 6CN-4 and 6CN-1 is open. 6CN-4 is at high level.	The command distribution or positioning is not complete (position error is above the preset value).

Set the output range in the following parameter to adjust the output timing of the positioning complete signal.

Cn-1B	Positioning Complete Width	Unit: Command Unit	Setting Range: 0 to 250	Factory Setting: 7
--------------	----------------------------	-----------------------	----------------------------	-----------------------

This parameter is used to set the output timing of the positioning complete signal (/POS1, 6CN-4) to be output when pulse distribution has been completed in the SERVOPACK.

Set the number of error pulses in command units (the minimum position command unit that is defined using the electronic gear function).

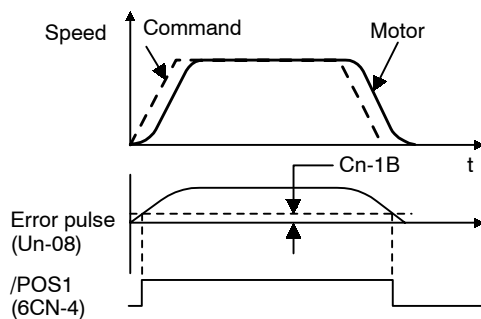

The positioning complete width has no effect on the final positioning accuracy.

Set the output condition in the following parameters to change the positioning-completed signal.

Cn-33 Bit F	Conditions for Positioning-Completed Signal	Factory Setting: 0
--------------------	---	--------------------

3

Setting	Meaning
0	ON when the position error is less than the value set for Cn-1B and without command distribution. Off while the operation-start signal (/AST) is ON, and until the zero-point return is successfully completed in the zero-point-return mode. (Standard specifications)
1	OFF when the power supply is ON. On when activating in the automatic operation mode to complete positioning if the command distribution is completed and the position error is less than the parameter Cn-1B. Also OFF under the following conditions: <ul style="list-style-type: none"> • Started in the automatic operation mode again, • Base block, • Mode has been changed, • Overtravelling occurred, or • While the operation-start signal is ON.

Note: Conditions for position-completed signal is available for software version 001C or later.

Output → /POS2 6CN-5	Positioning Proximity Output (/NEAR)
-----------------------------	--------------------------------------

This output signal indicates that the motor operation is near complete.

The host controller uses this signal as an interlock to prepare for the next command.

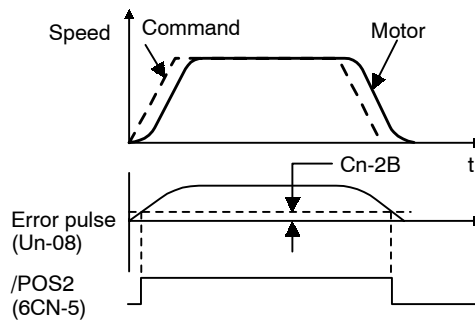

ON status	The circuit between 6CN-5 and 6CN-1 is closed. 6CN-5 is at low level.	Positioning complete is near (position error is below the preset value).
OFF status	The circuit between 6CN-5 and 6CN-1 is open. 6CN-5 is at high level.	Positioning complete is not near (position error is above the preset value).

Set the output range in the following parameter to adjust the output timing of the positioning proximity signal.

Cn-2B	Positioning Proximity Width	Unit: Command Unit	Setting Range: 0 to 3000	Factory Setting: 20
-------	-----------------------------	-----------------------	-----------------------------	------------------------

This parameter is used to set the output timing of the positioning proximity signal (/POS2, 6CN-5) when motor operation is complete.

Set the number of error pulses in command units (the minimum position command unit that is defined using the electric gear function).

If too large a value is set in this parameter, the error may become too small when the motor runs at a low speed, causing /POS2 signals to be output continuously.

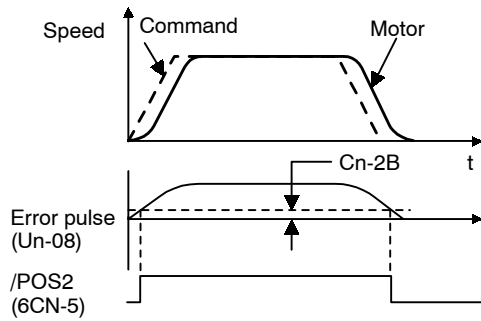

When automatic operation is in station number command mode, the positioning proximity signal can be changed to a station proximity signal.

Refer to 3.4.4 Station Proximity Signal.

3

3.2.12 Servo Ready Output Signal

This section describes how to wire and use a photocoupler output for the /S-RDY signal (servo ready).

“Servo ready” means that the SERVOPACK is not in servo alarm state when the main circuit is turned ON.

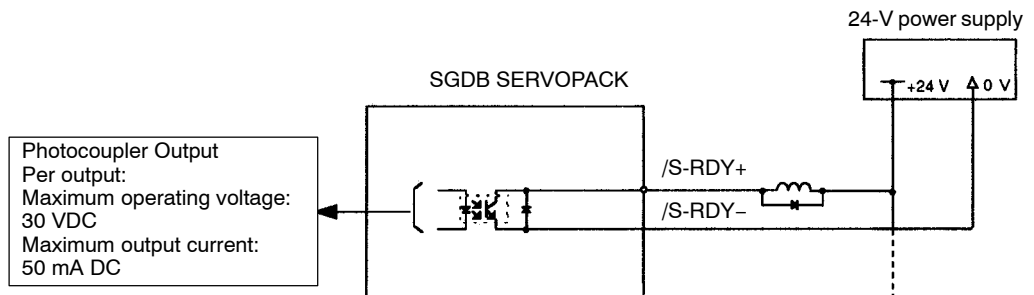

Output → /S-RDY	Servo Ready Output
------------------------	--------------------

This signal indicates that the SERVOPACK is ready to receive servo ON signals (/S-ON signal or SVON command).

ON status	Circuit is closed or signal is at low level.	Servo ready state
OFF status	Circuit is open or signal is at high level.	Not in servo ready state

Use the following parameter to specify the pin to which the /S-RDY signal is to be output.

Cn-2D	Output Signal Selection	Setting Range: 111 to 666	Factory Setting: 214
--------------	-------------------------	------------------------------	-------------------------

This parameter is used to specify a function signal as the 1CN output signal.

1's digit	Select the 1CN-16 and 1CN-17 (/BK) functions.
10's digit	Select the 1CN-18 and 1CN-19 (/TGON) functions.
100's digit	Select the 1CN-20 and 1CN-21 (/S-RDY) functions.

Setting	Function	Reference Section
1	/TGON	3.2.13
2	/S-RDY	3.2.12
3	/CLT	3.1.8
4	/BK	3.14.2
5	Overload warning	3.2.14
6	Overload alarm	3.2.14

Example: /S-RDY is output to 1CN-20 and 1CN-21.

Cn-2D=2□□

3.2.13 Running Detection Signal

This section describes how to wire and use photocoupler output for the running detection signal /TGON.

This signal indicates that a servomotor is currently running.

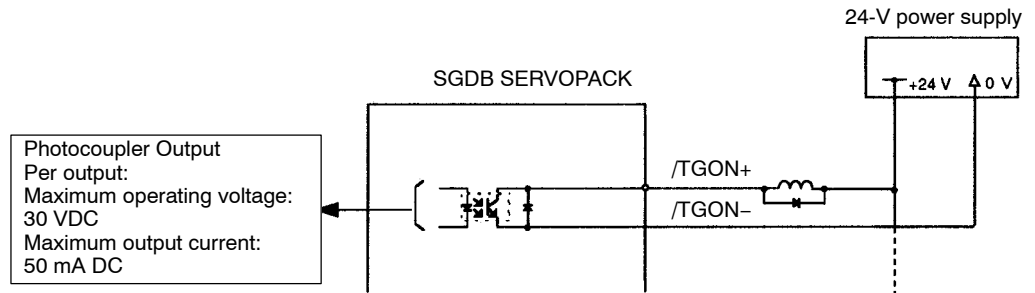

Output → /TGON Running Detection

This output signal indicates that the motor is currently running. It is used as an external interlock.

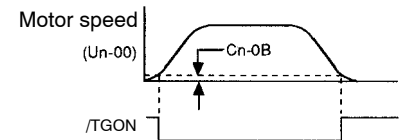

ON status	Circuit is closed or signal is at low level.	Motor is running. (Motor speed is greater than the preset value.)
OFF status	Circuit is open or signal is at high level.	Motor is stopped. (Motor speed is below the preset value.)

Use the following parameter to specify the pin to which the /TGON signal is to be output.

Cn-2D	Output Signal Selection	Setting Range: 111 to 666	Factory Setting: 214
--------------	-------------------------	------------------------------	-------------------------

This parameter is used to specify a function signal as the 1CN output signal.

1's digit	Select the 1CN-16 and 1CN-17 (/BK) functions.
10's digit	Select the 1CN-18 and 1CN-19 (/TGON) functions.
100's digit	Select the 1CN-20 and 1CN-21 (/S-RDY) functions.

Setting	Function	Reference Section
1	/TGON	3.2.13
2	/S-RDY	3.2.12
3	/CLT	3.1.8
4	/BK	3.14.2
5	Overload warning	3.2.14
6	Overload alarm	3.2.14

Example: /TGON is output to 1CN-18 and 1CN-19.

Cn-2D=□1□

Set the following parameter to specify the motor speed level at which running detection signals are output.

Cn-0B	Motor Speed Detection Level	Unit: min ⁻¹	Setting Range: 1 to 10000	Factory Setting: 20
--------------	-----------------------------	-------------------------	------------------------------	------------------------

This parameter is used to set the speed level at which the SERVOPACK determines that the motor is running and then outputs signals.

The following signals are output when motor speed exceeds the preset value. (The circuit is closed when motor speed exceeds the preset value.)

Output Signals when Motor Rotation is Detected:

- /TGON
- Bit 3 of serial communications internal status monitor signal MON5
- Bit 4 of Digital Operator internal status monitor 1 Un-05
- Digital Operator status display mode

3.2.14 OL Warning and Alarm Output Signals

This section describes how to wire and use photocoupler output signals OLWRN (overload warning) and OL (overload alarm).

These two output signals are output when operation under the rated current or more continues for a certain period of time. The overload warning signal is output in 20% of the time required to output the overload alarm signal.

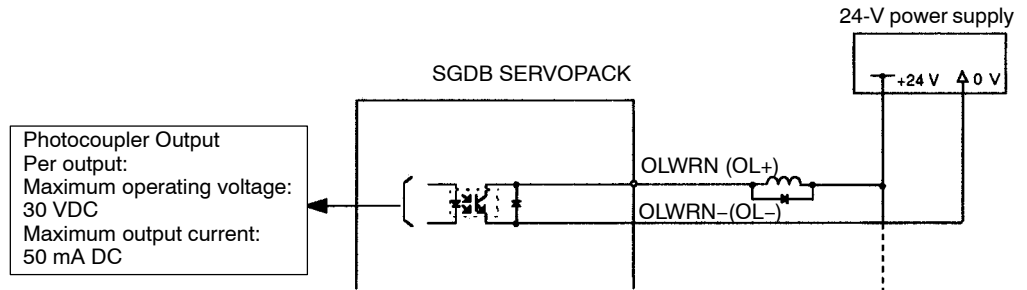
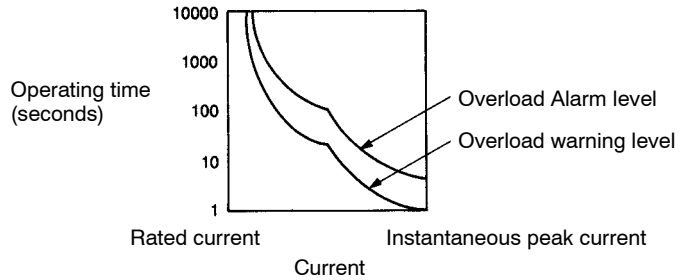

Output → OLWRN	Overload Warning Output
Output → OL	Overload Alarm Output

OLWRN is an overload warning output signal, and OL is an overload alarm output signal.

ON status	Circuit is closed or signal is at low level.	Normal state
OFF status	Circuit is open or signal is at high level.	Warning or alarm state

Use the following parameter to specify the pin to which the /TGON signal is to be output.

Cn-2D	Output Signal Selection	Setting Range: 111 to 666	Factory Setting: 214
--------------	-------------------------	------------------------------	-------------------------

This parameter is used to specify a function signal as the 1CN output signal.

1's digit	Select the 1CN-16 and 1CN-17 (/BK) functions.
10's digit	Select the 1CN-18 and 1CN-19 (/TGON) functions.
100's digit	Select the 1CN-20 and 1CN-21 (/S-RDY) functions.

Setting	Function	Reference Section
1	/TGON	3.2.13
2	/S-RDY	3.2.12
3	/CLT	3.1.8
4	/BK	3.14.2
5	Overload warning	3.2.14
6	Overload alarm	3.2.14

Example: Overload warning is output to 1CN-18 and 1CN-19.

Cn-2D=5

3

3.2.15 Analog Monitor Signals

Two monitor signals using analog voltages are output.

Output → TRQ-M 1CN-11	Torque Monitor Signal
Output → VTG-M 1CN-12	Speed Monitor Signal

The signal specifications for these outputs can be changed in the following memory switches.

Cn-02	Bit	Specifications	Factory Setting
Cn-02	Bit 6	TRQ-M Specifications	0
	Bit 7	VTG-M Specifications	0
	Bit E	Differential Pulse Monitor Level Switch	0

■ TRQ-M

Cn-02 Bit 6	Specifications
0	Torque monitor signals +2 V/+100% torque
1	Speed command monitor*

■ VTG-M

Cn-02 Bit 7	Specifications
0	Speed monitor*
1	Differential Pulse Monitor Cn-02 bit E = 0: ±0.05 V/±1 command unit Differential Pulse Monitor Cn-02 bit E = 1: ±0.05 V/±100 command unit

* The unit depends on the Motor Series.

SGMG or SGMD: $\mp 2 \text{ V}/\pm 1000 \text{ min}^{-1}$

SGMS, SGM, or SGMP: $\mp 1 \text{ V}/\pm 1000 \text{ min}^{-1}$

The analog monitor signals can be taken from the 5NC connector using a special cable (DE9404559).

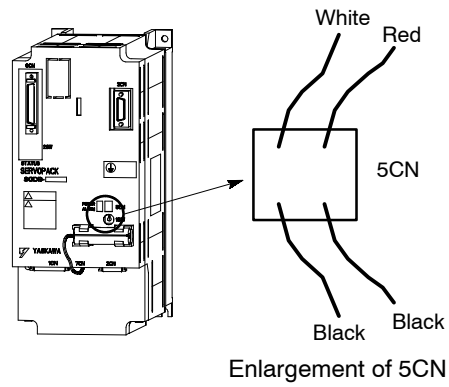

Cable Color	Signal Name	Signal
Red	VTG-M	Speed/Differential pulse monitor
White	TRQ-M	Torque/Speed command monitor
Black (two)	GND	Ground

3.3 Feed Speed Setting in Automatic and Manual Operation Modes

The feed speed setting method differs depending on the position command method set at parameter Cn-27 for automatic operation mode in the factory settings. These feed speed setting methods are outlined in the following table.

Cn-27 Setting	Position Command Method in Automatic Operation Mode	Feed Speed Setting Method
0	Station numbers	Select from 4 speeds set in parameter through contact input.
1	Digital switches	Set with digital switch.
2	Serial communications	Set in SPD command.
4	Command table	Select from speed table through contact input.

Refer to information on individual automatic mode operation methods for details on feed speed setting methods.

Set the following memory switch bit to change the feed speed setting method in automatic and manual operation modes.

Cn-32 Bit 5	Feed Speed Setting for Automatic Operation	Factory Setting: 0
--------------------	--	--------------------

Setting	Meaning
0	Feed speed setting methods for automatic operation outlined in the previous table.
1	Feed speed setting methods for automatic operation based on parameter Cn-18.

Cn-32 Bit 6	Feed Speed Setting for Manual Operation	Factory Setting: 0
--------------------	---	--------------------

Setting	Meaning
0	Feed speed setting methods for manual operation outlined in the previous table.
1	Feed speed setting methods for automatic operation based on parameter Cn-18.

If the bit in memory switch Cn-32 is set to 1, the feed speed settings for automatic and manual operation modes will be based on the 1s place and the 10s place of the Cn-18 setting, respectively. So, these feed speed settings will be independently selected.

However, only the Cn-18 settings shown in the following table can be specified depending on the position command method for automatic operation mode.

Cn-27 Setting	Position Command Method in Automatic Operation Mode	Cn-18 Setting		Feed Speed Setting Method
		Manual Operation Mode	Automatic Operation Mode	
0	Station numbers	0 <input type="checkbox"/>	<input type="checkbox"/> 0	Select from 4 speeds set in parameter through contact input.
		2 <input type="checkbox"/>	<input type="checkbox"/> 2	Set in SPD command.
1	Digital switches	0 <input type="checkbox"/>	<input type="checkbox"/> 0	Select from 4 speeds set in parameter through contact input.
		1 <input type="checkbox"/>	<input type="checkbox"/> 1	Set with digital switch.
		2 <input type="checkbox"/>	<input type="checkbox"/> 2	Set in SPD command.
2	Serial communications	0 <input type="checkbox"/>	<input type="checkbox"/> 0	Select from 4 speeds set in parameter through contact input.
		1 <input type="checkbox"/>	<input type="checkbox"/> 1	Set with digital switch.
		2 <input type="checkbox"/>	<input type="checkbox"/> 2	Set in SPD command.
		4 <input type="checkbox"/>	<input type="checkbox"/> 4	Select from speed table through contact input.
4	Command table	0 <input type="checkbox"/>	<input type="checkbox"/> 0	Select from 4 speeds set in parameter through contact input.
		2 <input type="checkbox"/>	<input type="checkbox"/> 2	Set in SPD command.
		4 <input type="checkbox"/>	<input type="checkbox"/> 4	Select from speed table through contact input.

Example: The following settings would be made for digital switch method (Cn-27 is set to 1), where the feed speed in automatic operation mode would be set in the SPD command and the speed data in manual mode would be “Select from 4 speeds set in the parameter through contact input”:

Bit 5 of Cn-32 = 1, bit 6 of Cn-32 = 1, and Cn-18 = 02.

Refer to 3.1.6 *Setting the Acceleration/Deceleration Type and Rate* for details on acceleration/deceleration types and speeds.

3.4 Automatic Mode: Station Numbers

This section explains how to operate the motor in automatic mode using station numbers (parameter Cn-27 set to 0).

The station number method is applicable to rotating machines. Stations are set at regular intervals at each machine rotation and positioning is performed to each station.

Set the following memory switch bit to use this method for rotating machines.

Cn-26 Bit 2	Linear/Rotating Mode Selection	Factory Setting: 0
--------------------	--------------------------------	--------------------

Setting	Meaning
0	Linear (position data range: -99999999 to +99999999)
1	Rotating (position data range: 0 to Cn-23 setting - 1)

Linear mode is applicable to machinery that moves in a linear direction, such as ball-screw driven machinery, conveyor belts, and roll feeders.

Rotating mode is applicable to machinery that return to the zero point after one rotation, such as disc tables and rotating ATCs.

Set the number of stations per rotation in the following parameter.

Cn-28	Number of Stations	Setting Range: 1 to 4096	Factory Setting: 1
--------------	--------------------	-----------------------------	--------------------

Note: If position data codes are set in BCD (bit 4 of Cn-26 is set to 1), the setting range for Cn-28 will be 1 to 1000.

Station numbers are allocated to each station. The zero point of the machine is station 0. The zero point of the machine is the preset zero point for absolute encoders or the position when zero point return operation is complete for incremental encoders. The station number is increased in the direction of forward rotation, e.g., station 1, station 2, to station (Cn-28 setting - 1).

Set the following memory switch bit to start station numbers from 1.

Cn-33 Bit 3	Station Number 0	Factory Setting: 0
--------------------	------------------	--------------------

Setting	Meaning
0	Includes station 0 (0, 1, . . . , Cn-28 setting -1)
1	Does not include station 0 (1, 2, . . . , Cn-28 setting)

Wiring examples for 1CN and 6CN using the station number method are shown in the following diagram.

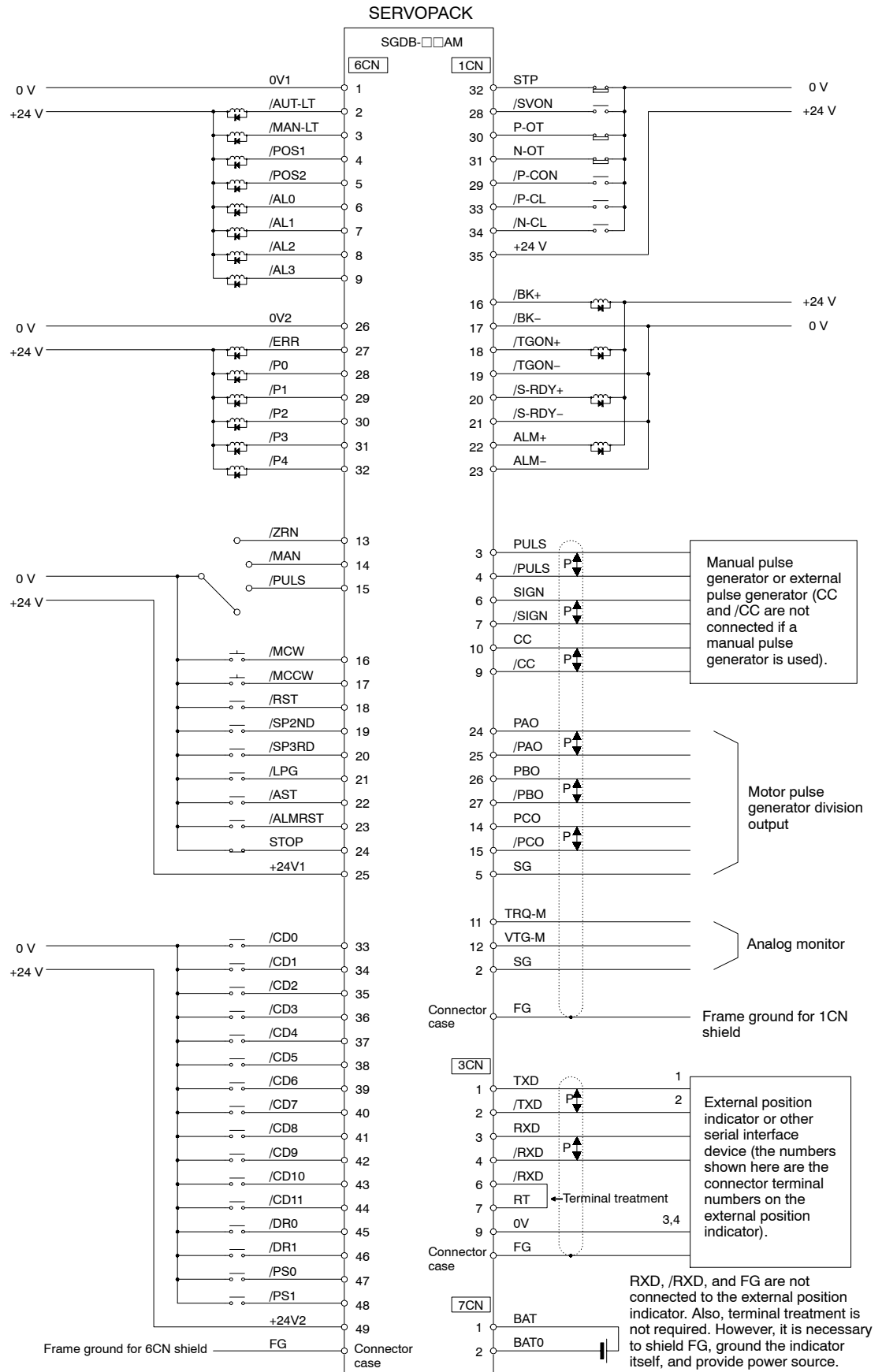

I/O signals for the station number method are shown below. Refer to 3.2 *Signals Common to All Modes* for details on signals not listed here.

3.4.1 Position Command Input Signals

These signals are contact data input signals that designate positioning station numbers.

→ Input /CD0 6CN-33	Station Number Command Data
→ Input /CD1 6CN-34	Station Number Command Data
→ Input /CD2 6CN-35	Station Number Command Data
→ Input /CD3 6CN-36	Station Number Command Data
→ Input /CD4 6CN-37	Station Number Command Data
→ Input /CD5 6CN-38	Station Number Command Data
→ Input /CD6 6CN-39	Station Number Command Data
→ Input /CD7 6CN-40	Station Number Command Data
→ Input /CD8 6CN-41	Station Number Command Data
→ Input /CD9 6CN-42	Station Number Command Data
→ Input /CD10 6CN-43	Station Number Command Data
→ Input /CD11 6CN-44	Station Number Command Data

Binary or BCD can be selected for the position data code. Set position data code in the following memory switch bit.

Cn-26 Bit 4	Position Data Code	Factory Setting: 0
Setting	Meaning	
0	Binary	
1	BCD (binary coded decimal)	

Station number command data codes for each contact are shown in the following table.

Cn-26 Bit 4	Data Code	/CD0	/CD1	/CD2	/CD3	/CD4	/CD5	/CD6	/CD7	/CD8	/CD9	/CD10	/CD11
0	Binary (0 to 4095)	1	2	4	8	16	32	64	128	256	512	1024	2048
1	BCD (0 to 999)	1	2	4	8	10	20	40	80	100	200	400	800

The command value will be the sum of the closed signal codes (low level) from CD0 to CD11.

Example: When CD0, CD5, and CD10 are closed:

The command value = $1 + 32 + 1024 = 1057$ for binary data code.

The command value = $1 + 20 + 400 = 421$ for BCD data code.

Set the following memory switch bit to select absolute or incremental position command mode.

Cn-26 Bit 3	Position Command Mode	Factory Setting: 0
--------------------	-----------------------	--------------------

Setting	Meaning
0	Absolute
1	Incremental

In absolute position command mode, the specified station number will be the positioning command. In incremental position command mode, the station number for the positioning command will be the station number where the machine is currently stopped \pm command value.

The diagram below shows the machine movement after the operation start signal AST is input if the rotating direction select signal /DR0 is closed (low level), /DR1 is open (high level), the machine is currently stopped at station number 5, and the value for command data /CD0 to /CD11 is 3.

Absolute mode	Moves to station number 3 (←---)	
Incremental mode	Moves to station number 8 (←—)	

Note: If the data code is in BCD, values for /CD0 to /CD3, /CD4 to /CD7, and /CD8 to /CD11 cannot exceed 9, 90, or 900 respectively. Otherwise, a position error will occur.

3.4.2 Rotating Direction Select Input

Select the rotating direction in automatic operation mode for the station number method.

→ Input /DR0 6CN-45	Rotating Direction Selection
→ Input /DR1 6CN-46	Rotating Direction Selection

Combinations of these two signals give the following rotation directions in automatic operation mode.

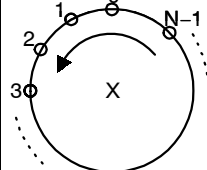
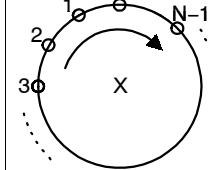
Signal Cn-26 Bit 3	/DR0	Open (High Level)	Closed (Low Level)	Open (High Level)	Closed (Low Level)
	/DR1	Open (High Level)	Open (High Level)	Closed (Low Level)	Closed (Low Level)
0	Absolute mode	Shortcut rotation direction	Direction towards greater station number Example: 	Direction towards smaller station number Example: 	Position error generated for this setting.
1	Incremental mode	Position error generated for this setting.			

3

3.4.3 Current Station Number Output and Station Number Read Selection Input

The current motor position can be output as a station number.

→ Input /PS0 6CN-47	Station Number Read Selection
→ Input /PS1 6CN-48	Station Number Read Selection

→ Input /P0 6CN-28	Current Position Data Output
→ Input /P1 6CN-29	Current Position Data Output
→ Input /P2 6CN-30	Current Position Data Output
→ Input /P3 6CN-31	Current Position Data Output
→ Input /P4 6CN-32	Current Position Data Output

The current motor position by station number is read using current position data output signals /P0 to /P4. As /P0 to /P4 have only 5 bits, switch the digit by using station number read selection signals /PS0 and /PS1 and read the station numbers in order. The following table shows the different codes for output signals /P0 to /P4 change depending on the combinations of open and closed settings for /PS0 and /PS1. The sum of the codes for signals /P0 to /P4 that are closed (low level) will be the station number of the current motor position.

Input Signal	/PS0	Open (High Level)	Closed (Low Level)	Open (High Level)	Closed (Low Level)
Output Signal	/PS1	Open (High Level)	Open (High Level)	Closed (Low Level)	Closed (Low Level)
Binary Cn-26 Bit 4 = 0	/P0	1	1	16	256
	/P1	2	2	32	512
	/P2	4	4	64	1024
	/P3	8	8	128	2048
	/P4	16	Odd parity	Odd parity	Odd parity
BCD Cn-26 Bit 4 = 1	/P0	1	1	10	100
	/P1	2	2	20	200
	/P2	4	4	40	400
	/P3	8	8	80	800
	/P4	10	Odd parity	Odd parity	Odd parity

Note: 1. When /PS0 and /PS1 are at high level, /P4 becomes a parity bit. For example, in BCD notation, if the value for /P0 to /P3 is 7 when /PS0 is at low level and /PS1 is at high level, /P4 will be set at high level so that the total number of signals at low levels is odd (in this example, 3: /P0 = low, /P1 = low, /P2 = low, and /P3 = high).

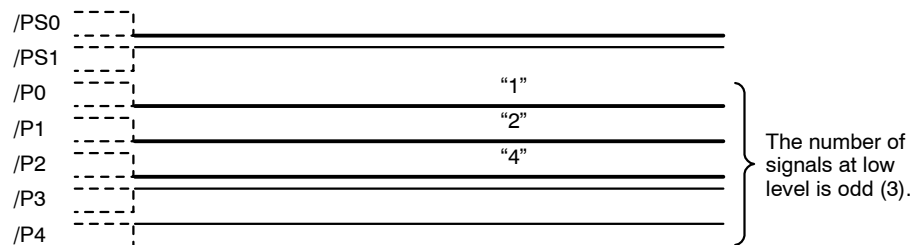

2. When reading current data (station numbers) separately over several times, set the read timing as follows:

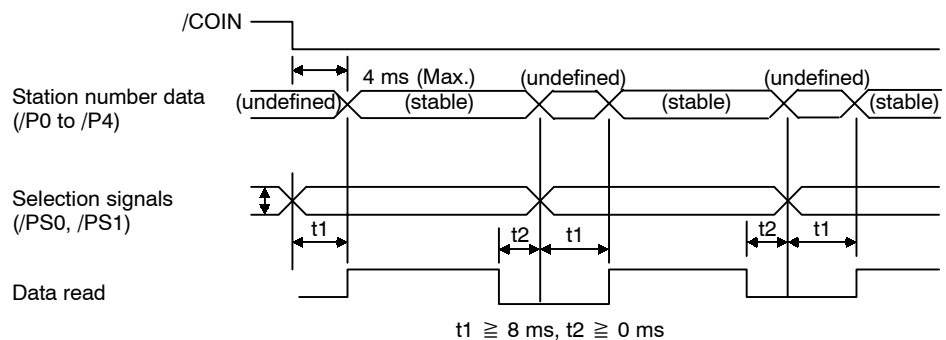

When using the station number method, set the following memory switch bit to output the left-most digits of the current position station numbers (/P5 to /P8) to 6CN-6, -7, -8, and -9. In this case, alarm and error code output signals (/AL0 to /AL3) cannot be used.

Cn-33 Bit 4	Station Number Output Expansion	Factory Setting: 0
Setting	Meaning	
0	Outputs alarm and error codes (/AL0 to /AL3) to 6CN-6 to 6CN-9.	
1	Outputs leftmost digits of current position station numbers (/P5 to /P8) to 6CN-6 to 6CN-9.	

The codes for signals /P5 to /P8 are shown in the following table.

Binary Cn-26 Bit 4 = 0	/P5	32
	/P6	64
	/P7	128
	/P8	256
BCD Cn-26 Bit 4 = 1	/P5	20
	/P6	40
	/P7	80
	/P8	100

Note: /P5 to /P8 signal codes do not change according to /PS0 and /PS1 signals.

3.4.4 Station Proximity Signal

When using the station number method, set the following memory switch bit to change POS2 (positioning proximity signal) to a station proximity signal.

Cn-33 Bit 4	Station Proximity Signal	Factory Setting: 0
Setting	Meaning	
0	Sets /POS2 (6CN-5) as a positioning proximity signal.	
1	Sets /POS2 (6CN-5) as a station proximity signal.	

The output range for station proximity signals is set using the following parameter, the same as for positioning proximity signals.

Cn-2B	Positioning Proximity Width	Unit: Command Unit	Setting Range: 0 to 3000	Factory Setting: 20
--------------	-----------------------------	--------------------	--------------------------	---------------------

The differences between station proximity signals and positioning proximity signals is outlined in the following table.

Positioning Proximity Signal
<ul style="list-style-type: none"> • This signal is closed (at low level) when the current motor position is within the range of command position \pm Cn-2B during automatic operation. • This signal is always closed (at low level) until automatic operation starts. • This signal is always closed (at low level) when the motor is OFF (servo OFF).

Station Proximity Signal

- This signal is closed (at low level) when the current motor position is within the range of each station position $\pm Cn-2B$.
- This signal is closed (at low level) even when the current position is a station position other than the specified station position (such as station positions passed during operation).
- This signal is active even when the motor is OFF (servo OFF), for example, when the motor shaft is moved by an external force.

3.4.5 Manual Operation Mode

If the station number method is specified for position referencing in automatic operation mode, the motor will perform positioning and then stop at the nearest station position at which it can stop at the specified deceleration rate when the manual operation signal (/MCCW, /MCW) is open (at high level) during manual operation (fixed-point positioning). The motor may stop at the station after the nearest station depending on the deceleration rate.

Refer to 3.8 *Manual Mode* for details.

3.4.6 Inputting Speed Command Data

When using station numbers, the factory setting for the speed command method is to select from 4 speeds set in parameters through contact inputs. In this speed command method, feed speeds are specified in the following four parameters and one of these is selected through the contact inputs.

Cn-1F	First Feed Speed	Unit: ×1000 Command Units/min.	Setting Range: 1 to 240000	Factory Setting: 500
--------------	------------------	--------------------------------------	-------------------------------	-------------------------

Cn-20	Second Feed Speed	Unit: ×1000 Command Units/min.	Setting Range: 1 to 240000	Factory Setting: 100
--------------	-------------------	--------------------------------------	-------------------------------	-------------------------

Cn-21	Third Feed Speed	Unit: ×1000 Command Units/min.	Setting Range: 1 to 240000	Factory Setting: 200
--------------	------------------	--------------------------------------	-------------------------------	-------------------------

Cn-22	Forth Feed Speed	Unit: ×1000 Command Units/min.	Setting Range: 1 to 240000	Factory Setting: 300
--------------	------------------	--------------------------------------	-------------------------------	-------------------------

This section describes how to wire and use contact input signals /SP2ND and /SP3RD. These signals are used when selecting one of the four feed speeds outlined on the previous page.

3

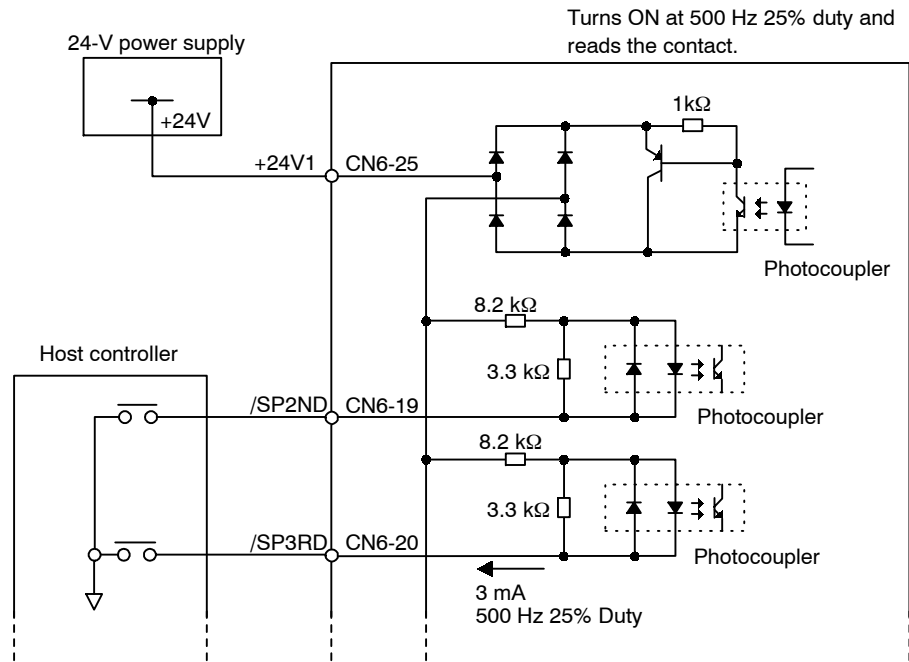

→ Input /SP2ND 6CN-19	Speed Selection Code Input 1
→ Input /SP3RD 6CN-20	Speed Selection Code Input 2

The relationship between the contact status and the selected feed speed is shown in the following table.

/SP2ND	/SP3RD	Specified Feed Speed
Open (high)	Open (high)	First Feed Speed (Cn-1F)
Close (low)	Open (high)	Second Feed Speed (Cn-20)
Open (high)	Close (low)	Third Feed Speed (Cn-21)
Close (low)	Close (low)	Forth Feed Speed (Cn-22)

If the speed command is set to select from 4 speeds set in parameters through contact inputs, the feed speed can be changed while in manual operation mode.

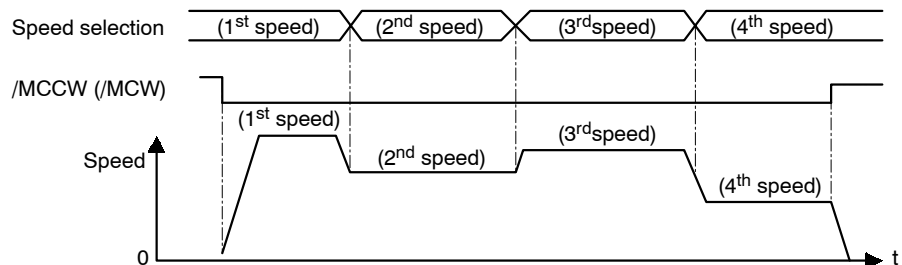

Set the following memory switch bit to change the feed speed while in automatic operation mode.

Cn-32 Bit 2	Speed Command Change during Automatic Operation	Factory Setting: 0
--------------------	---	--------------------

Setting	Meaning
0	Does not change the feed speed during automatic operation.
1	Changes the feed speed during automatic operation.

When using the station number method, the feed speed in automatic and manual operation modes can be set to set using the SPD serial command. Refer to 3.3 *Feed Speed Setting in Automatic and Manual Operation Modes* for details on how to change the feed speed setting method.

When using the digital switch method, the operation of changing the set value interferes with the strobe operation and may cause unexpected value inputs. Do not change the command speed when using digital switches.

3.5 Automatic Mode: Digital Switches

This section explains motor operation in automatic mode using digital switches (parameter Cn-27 set to 1.)

Wiring for 1CN and 6CN for the digital switch method is shown on the following page.

3

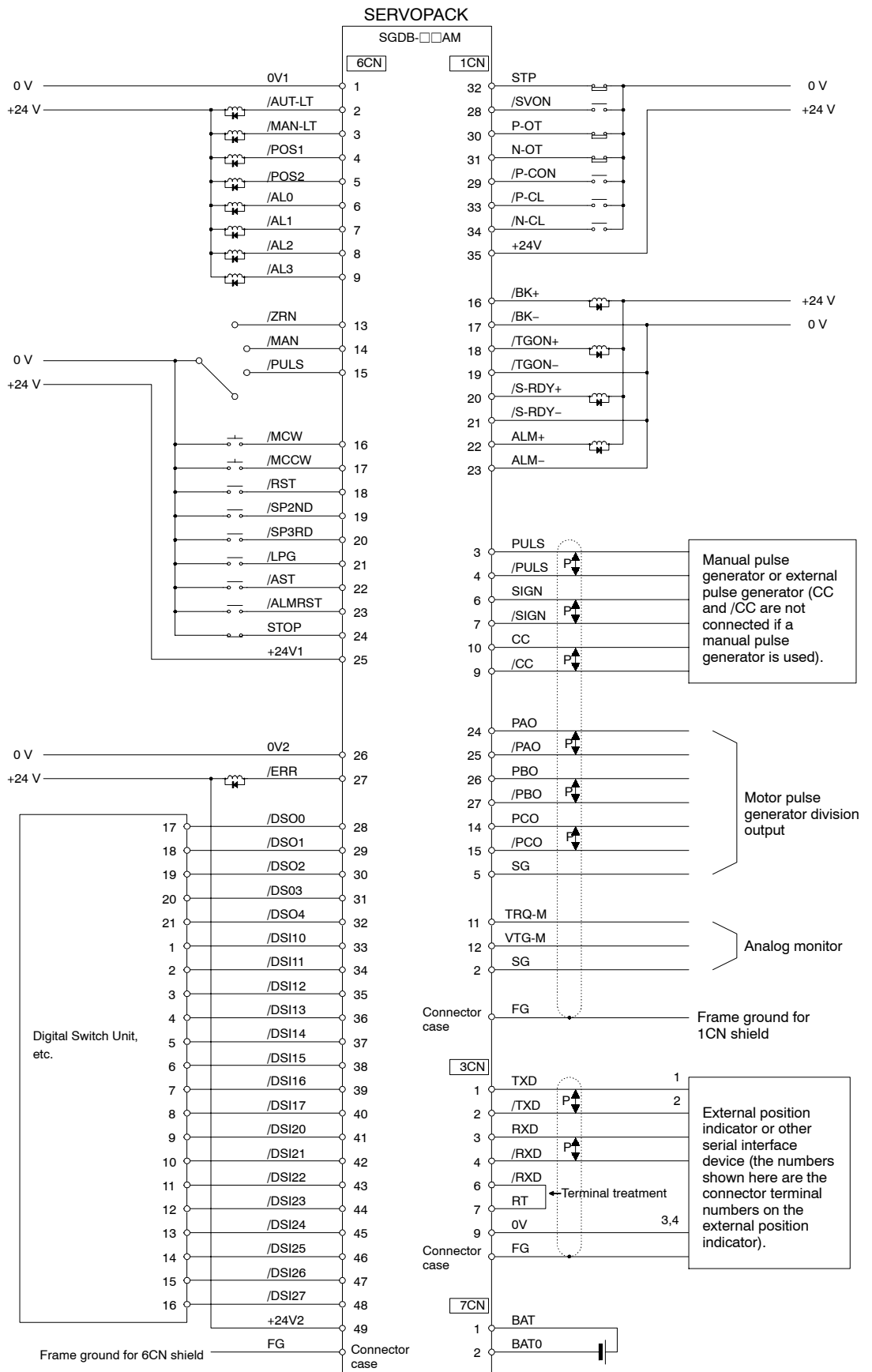

The I/O signals for the digital switch method are outlined below. Refer to 3.2 *Signals Common to All Modes* for details on signals not listed here.

3.5.1 Position Command Input Signals, Speed Command Input Signals, and Strobe Output Signals

I/O signals for reading target position and feed speed digital switches are outlined in the following table.

Target position settings are in command units and feed speed settings are in $\times 1000$ command units/min.

→ Input /DSI10 6CN-33	Digital Switch Position Data
→ Input /DSI11 6CN-34	Digital Switch Position Data
→ Input /DSI12 6CN-35	Digital Switch Position Data
→ Input /DSI13 6CN-36	Digital Switch Position Data
→ Input /DSI14 6CN-37	Digital Switch Position Data
→ Input /DSI15 6CN-38	Digital Switch Position Data
→ Input /DSI16 6CN-39	Digital Switch Position Data
→ Input /DSI17 6CN-40	Digital Switch Position Data
→ Input /DSI20 6CN-41	Digital Switch Speed Data
→ Input /DSI21 6CN-42	Digital Switch Speed Data
→ Input /DSI22 6CN-43	Digital Switch Speed Data
→ Input /DSI23 6CN-44	Digital Switch Speed Data
→ Input /DSI24 6CN-45	Digital Switch Speed Data
→ Input /DSI25 6CN-46	Digital Switch Speed Data
→ Input /DSI26 6CN-47	Digital Switch Speed Data
→ Input /DSI27 6CN-48	Digital Switch Speed Data

Output → /DSO0 6CN-28	Digital Switch Read Strobe Signal
Output → /DSO1 6CN-29	Digital Switch Read Strobe Signal
Output → /DSO2 6CN-30	Digital Switch Read Strobe Signal
Output → /DSO3 6CN-31	Digital Switch Read Strobe Signal
Output → /DSO4 6CN-32	Digital Switch Read Strobe Signal

Each signal function is outlined below.

Signal Name	Signal Group	Effective Logic	Function						
/DSI10	Position command input	Closed (low)	1	10 ⁰ digit	10 ² digit	10 ⁴ digit	10 ⁶ digit	Reads 2 digits (BCD) each of position and speed commands selected in the data strobe output signals shown below.	
/DSI11			2						
/DSI12			4						
/DSI13			8						
/DSI14			1	10 ¹ digit	10 ³ digit	10 ⁵ digit	10 ⁷ digit		
/DSI15			2						
/DSI16			4						
/DSI17			8						
/DSI20	Speed command input	Closed (low)	1	10 ⁰ digit	10 ² digit	10 ⁴ digit			
/DSI21			2						
/DSI22			4						
/DSI23			8						
/DSI24			1	10 ¹ digit	10 ³ digit	10 ⁵ digit			
/DSI25			2						
/DSI26			4						
/DSI27			8						
/DSO0	Strobe output	Closed (low)							Reads 2 digits each of position and speed commands for which the data strobe signal is closed (at low level).
/DSO1									
/DSO2									
/DSO3									
/DSO4									

Strobe signals turn ON in order (/DSO0, /DSO1, /DSO2, /DSO3, /DSO4, /DSO0, ...) and read the digit written above the position where each of the signals in the table is closed (at low level).

3

The factory setting for time width (digital switch read scan time) for one strobe signal to close (set at low level) is 24 ms.

Set the following parameter to change the digital switch read scan time if position and speed commands are specified using devices (such as PLCs) other than a special Digital Switch Unit.

Cn-38	Digital Switch Read Scan Time	Unit: ms	Setting Range: 12 to 2000	Factory Setting: 24
--------------	-------------------------------	----------	---------------------------	---------------------

The SERVOPACK requires 24 ms to read data. Therefore, the Cn-38 setting must be equal to 24 ms plus the time required to send data from the device (such as PLC) that outputs position and speed commands.

If the scan time has been changed, the SERVOPACK reads digital switch data during the last 24 ms of the scan time.

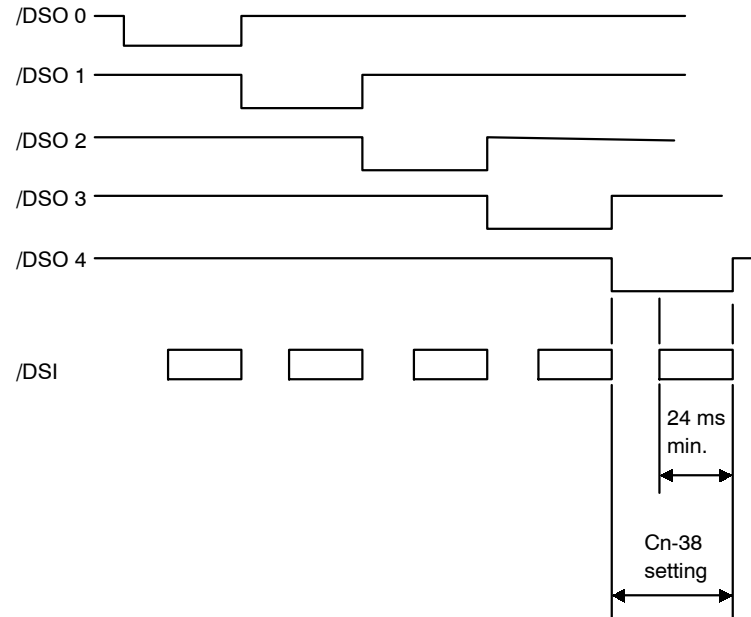

Example:

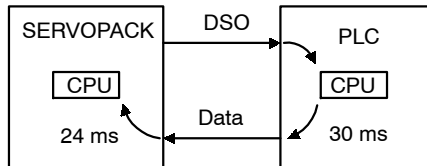

$$\text{Cn-38 setting} = 30 \text{ ms} + 24 \text{ ms} = 54 \text{ ms minimum.}$$

When using the digital switch method, select BCD as the position data code in the following memory switch bit.

Cn-26 Bit 4	Position Data Code	Factory Setting: 0
--------------------	--------------------	--------------------

Setting	Meaning
0	Binary
1	BCD (binary coded decimal)

Note: After changing scan time or position data code settings, output position and speed data from the host controller and use the serial communications monitor command (MOND, MONE) or Digital Operator monitor mode (Un-0d, Un-0E) to confirm that the SERVO-PACK is reading the command data correctly. Be sure to do so before starting operation.

If operation is started while command data is not being read correctly, positioning will be incorrect, and the machine may be damaged or injuries may occur.

Refer to 4.4.2 *Command Details* for details on serial communications monitor commands and 5.1.11 *Monitor Mode* for details on the Digital Operator monitor mode.

Set the following memory switch bit to select the position command mode (absolute or incremental.)

Cn-26 Bit 3	Position Command Mode	Factory Setting: 0
--------------------	-----------------------	--------------------

Setting	Meaning
0	Absolute
1	Incremental

When absolute position command mode is selected, positioning will be performed at the specified coordinates. The motor will rotate in the forward direction if the coordinate value of the current position is smaller than the coordinate value of the command position. The motor will rotate in the reverse direction if the coordinate value of the current position is greater than the coordinate value of the command position.

When incremental position command mode is selected, positioning will be performed at the current position coordinates + specified coordinates. If the command input sign is positive, the motor will rotate in the forward direction. If it is negative, the motor will rotate in the reverse direction.

3.5.2 Speed Command

The factory setting for the speed command method when using digital switches is to set the speed command using digital switches. Refer to 3.5.1 *Position Command Input Signals, Speed Command Input Signals, and Strobe Output Signals* for details on how to set speed commands using the digital switches.

When using the digital switch method, the feed speed in automatic and manual operation modes can be set to select the speed from 4 speeds set in parameters through contact inputs or to set the speed using the SPD serial command. Refer to 3.3 *Feed Speed Setting in Automatic and Manual Operation Modes* for details on how to change the feed speed setting method.

3.5.3 Digital Switch Unit

The Yaskawa MCIF-D86 Digital Switch Unit internal connections and wiring for connections to the SERVOPACK are shown in the following diagram.

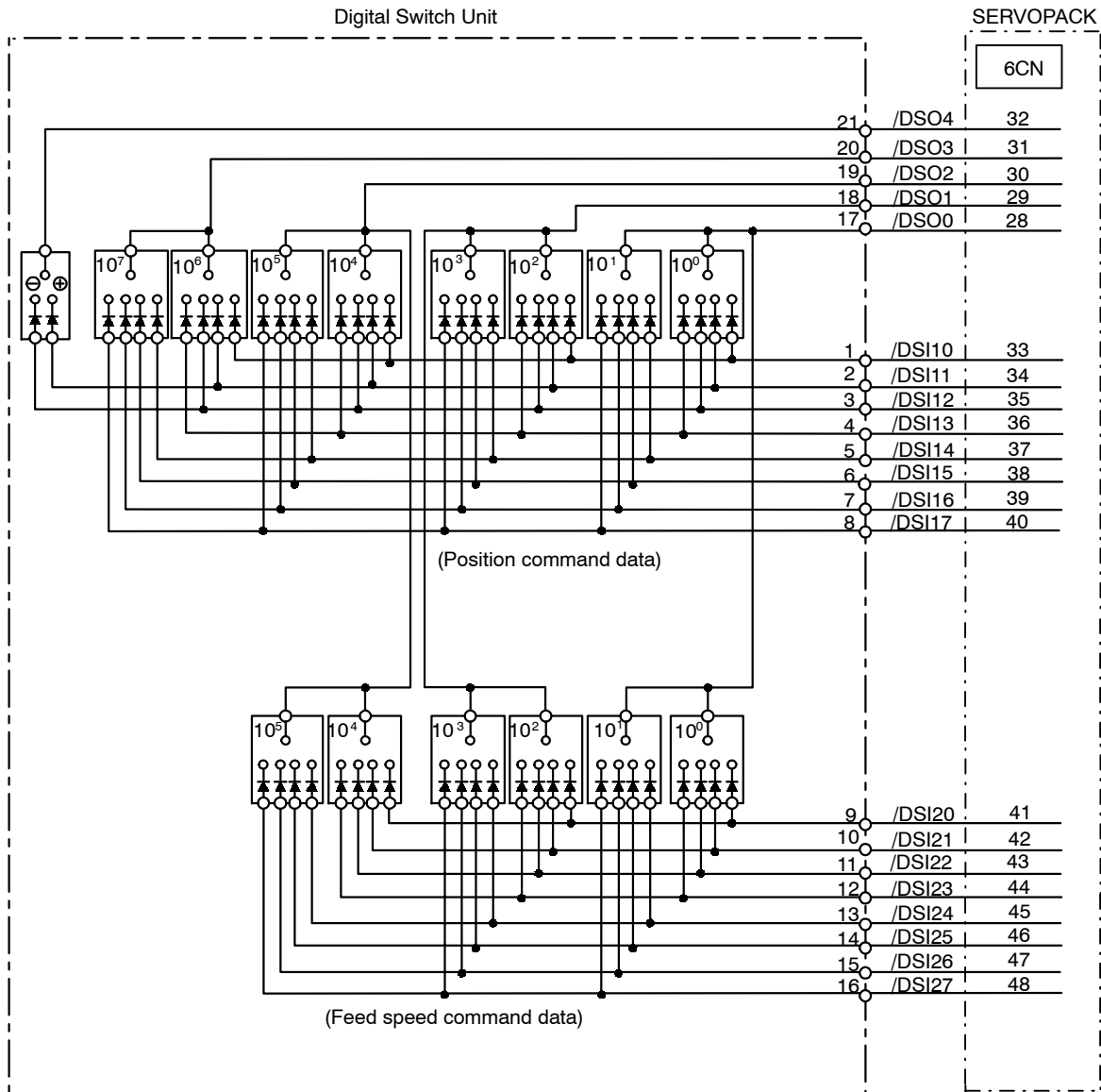

3

If only the speed command is to be input from the Digital Switch Unit, however, connect a one-step Digital Switch Unit to the SERVOPACK as shown in the following diagram. In this connection method, sign digit in the Digital Switch Unit will be ignored.

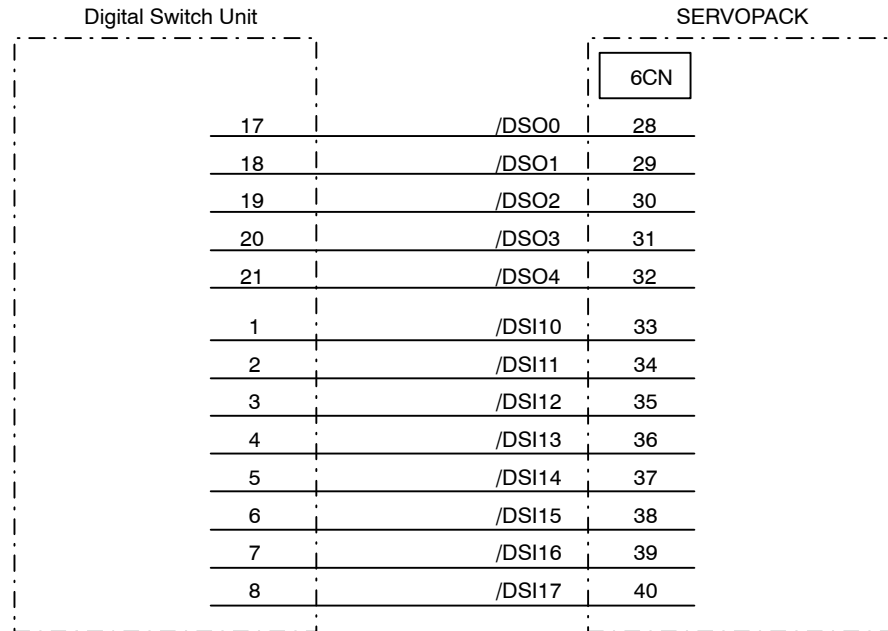

Refer to 6.6.18 *Digital Switch Unit (MCIF-D□□)* for details on the Digital Switch Unit.

3.5.4 Contact Input Unit

An MCIF-R86 Contact Input Unit is required if Digital Switch Units other than the special Digital Switch Unit (MCIF-D86) are used or all digit numerals are output at independent contacts without using strobe signals from PLC or some other device.

Command Input and Contact Input Unit wiring to the SERVOPACK is shown in the following diagram.

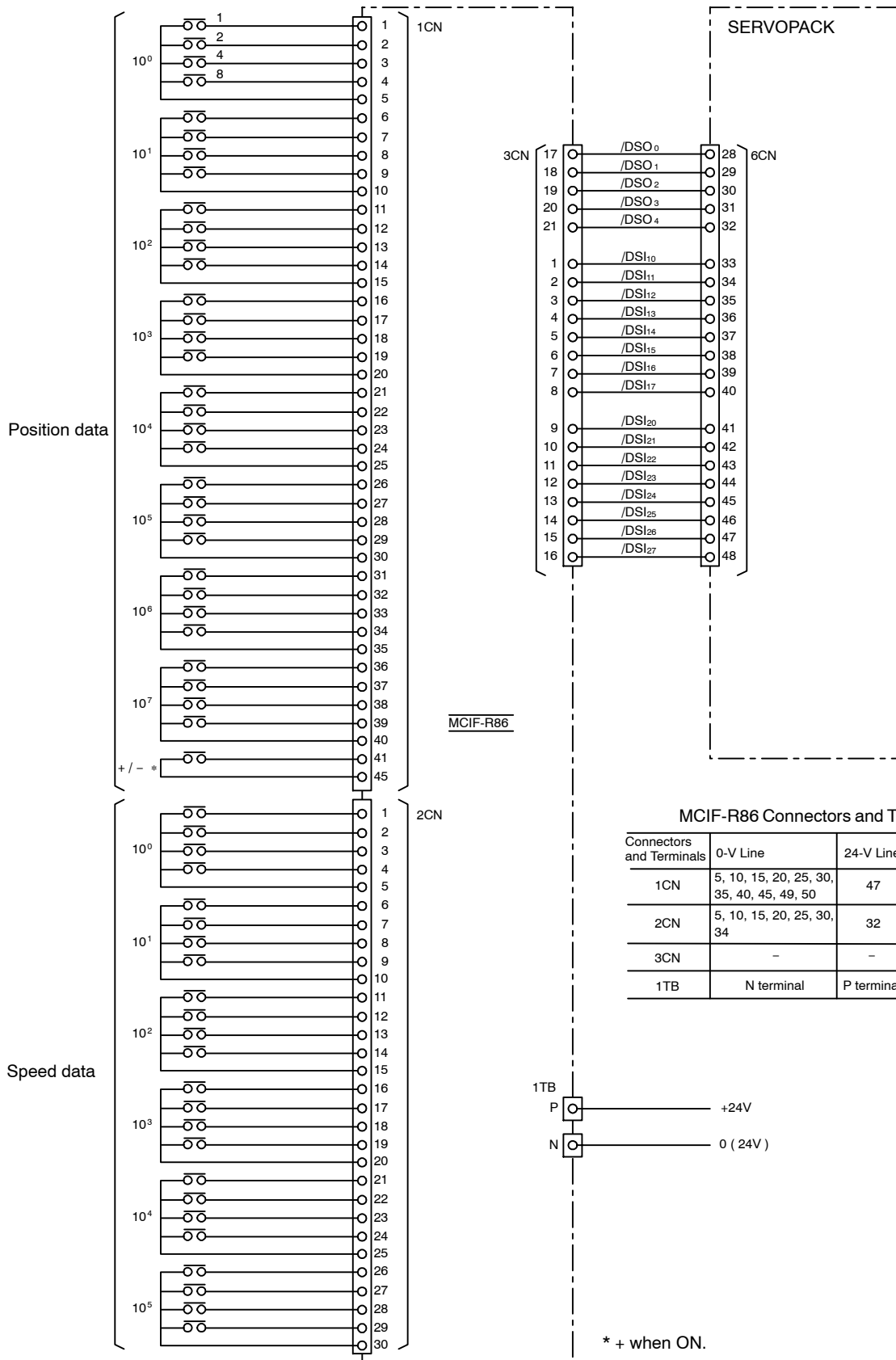

MCIF-R86 Connectors and Terminals

Connectors and Terminals	0-V Line	24-V Line	Unused Pins
1CN	5, 10, 15, 20, 25, 30, 35, 40, 45, 49, 50	47	46, 48
2CN	5, 10, 15, 20, 25, 30, 34	32	31, 33
3CN	-	-	22, 23, 24, 25
1TB	N terminal	P terminal	-

* + when ON.

Refer to 6.6.19 Contact Input Unit (MCIF-R86) for details on the Contact Input Unit.

3.6 Automatic Mode: Serial Communications

This section explains how to operate the motor using serial communications (parameter Cn-27 set to 2) in automatic operation mode.

Refer to *Chapter 4 Using Serial Communications* for details on serial communications specifications and wiring.

Note: This section also explains operation using serial communications in other modes.

1CN, 3CN, and 6CN wiring for the serial communications method is shown in the following diagram.

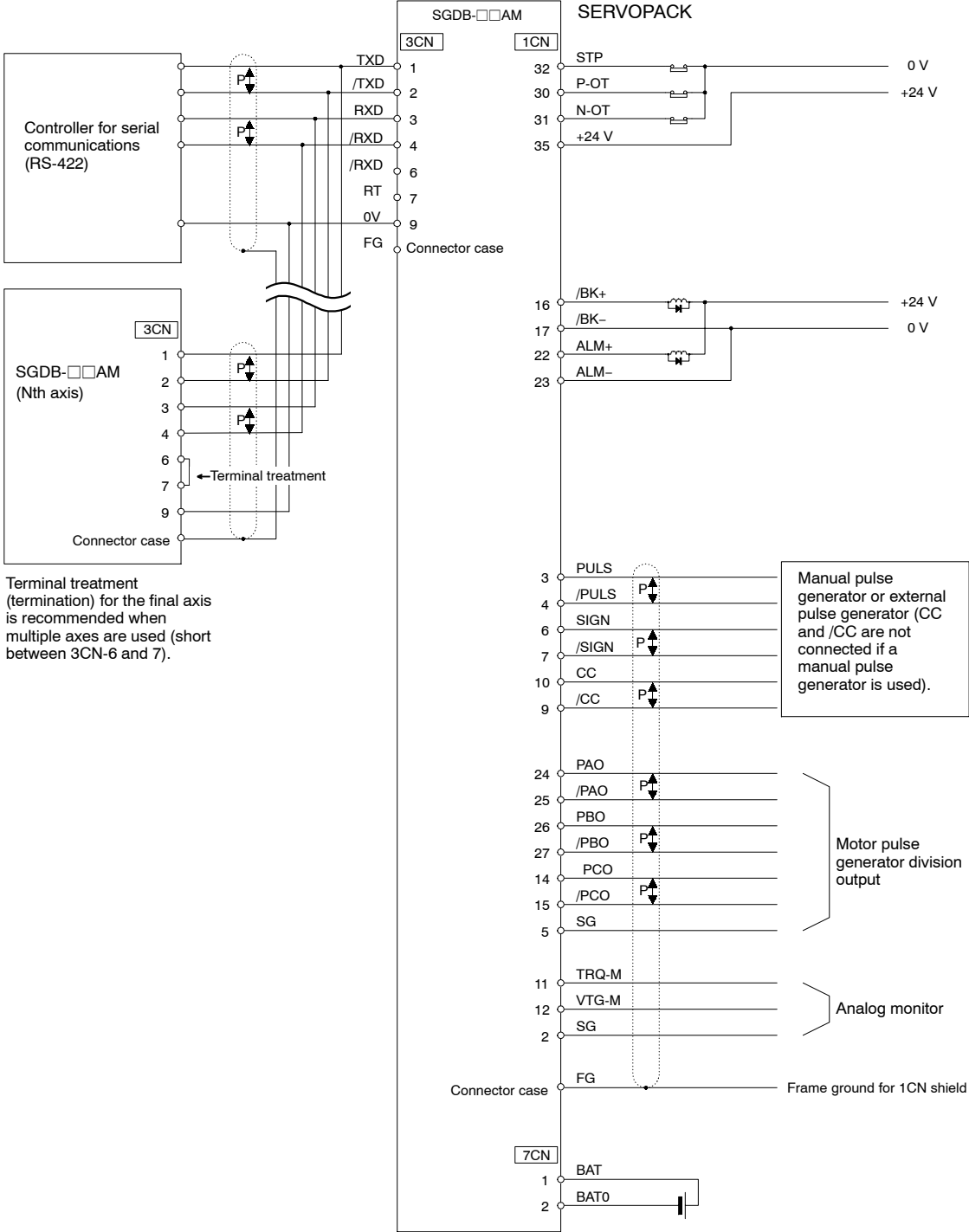

3.6.1 Serial Commands

This section explains the commands related to motor operation only. Refer to *Chapter 4 Using Serial Communications* for information on other commands.

The commands for motor operation are listed below.

List of Commands for Motor Operation

Note: The commands for normal mode are shown above the dotted lines and the commands for fixed-length mode are shown below the dotted line. A checksum must be added after a command in fixed-length mode. Refer to *4.3 Using Fixed Length Mode* for details on fixed-length mode and *4.1.3 Baud Rate and Command Length Mode Settings* for details on normal and fixed-length modes.

	Command	Meaning
	Top line: Normal Bottom line: Fixed length	
Operation Commands	SVON	Turns ON the motor.
	SON	
	SVOFF	Turns OFF the motor.
	SOF	
	PON	Turns ON pulse operation mode.
	PON	
	POFF	Turns OFF pulse operation mode.
	POF	
	PCON	Sets speed loop to proportional (P) control.
	PCN	
	PCOFF	Sets speed loop to proportional/integral (PI) control.
	PCF	
	ZERASET (\pm) nnnnnnnn	Sets the machine zero point so that the current position will be (\pm) nnnnnnnn.
	ZST (\pm) nnnnnnnn	
	SET (\pm) nnnnnnnn	Sets the work zero point shifted from the machine zero point so that the current position will be (\pm) nnnnnnnn.
	SET (\pm) nnnnnnnn	
	CLR	Turn the offset 0, and then match the work zero point with the machine zero point.
	CLR	
	RES	Performs the same operation as if manually turning the control power supply OFF and then ON again.
	RES	

	Command Top line: Normal Bottom line: Fixed length	Meaning
Operation Commands	ARES	Resets the alarm.
	ARS	
	FZU	For manual adjustment of the U-phase current offset.
	FZU	
	FZV	For manual adjustment of the V-phase current offset.
	FZV	
Move Commands	SPDnnnnnn	Sets speed command value.
	SPDnnnnnn	
	MOV(±)nnnnnnnn	Sets absolute position command value.
	MOV(±)nnnnnnnn	
	MOVI(±)nnnnnnnn	Sets incremental position command value.
	MVI(±)nnnnnnnn	
	ST	Starts automatic operation.
	STR	
	POS(±)nnnnnnnn	Moves to an absolute position of ± nnnnnnnn to perform positioning at linear acceleration/deceleration rate.
	POS(±)nnnnnnnn	
	POSI(±)nnnnnnnn	Moves to an incremental position at ± nnnnnnnn to perform positioning at linear acceleration/deceleration rate.
	POI(±)nnnnnnnn	
	EXP(±)nnnnnnnn	Rotates in the forward direction to perform positioning at command point ± nnnnnnnn (external positioning).
	EXP(±)nnnnnnnn	
	EXN(±)nnnnnnnn	Rotates in the reverse direction to perform positioning at command point ± nnnnnnnn (external positioning).
	EXN(±)nnnnnnnn	
	JOGP	Starts manual operation in forward direction.
	JGP	
	JOGN	Starts manual operation in reverse direction.
	JGN	
	JOG(±)nnnnnn	Starts operation at a constant speed of ± nnnnnn.
	JOG(±)nnnnnn	

	Command Top line: Normal Bottom line: Fixed length	Meaning
Move Commands	ZRN	Starts zero point return operation.
	ZRN	
	SKIP	Decelerates to stop.
	SKP	
	HOLD	Performs feed hold (holds residual data).
	HLD	

Communications Errors

Refer to the following table if a communications error occurs after a command is sent. Examine the cause of the error and resend the command once the error has been cleared.

Yes: ERR OV only for too many digits.

No: No error.

	Command Top line: Normal Bottom line: Fixed length	ERR PN	ERR OV	ERR SN
Operation Commands	SVON	No	No	Output with RST ON, OL status
	SON			
	SVOFF	No	No	–
	SOF			
	PON	No	No	Motor not turned ON.
	PON			
	POFF	No	No	Not in pulse mode.
	POF			
	PCON	No	No	–
	PCN			
	PCOFF	No	No	–
	PCF			
	ZEROSSET (±) nnnnnnnn	No	Yes	–
	ZST (±) nnnnnnnn			

	Command Top line: Normal Bottom line: Fixed length	ERR PN	ERR OV	ERR SN
Operation Commands	SET (±) nnnnnnnn	No	Yes	-
	SET (±) nnnnnnnn			
	CLR	No	No	-
	CLR			
	RES	No	No	-
	RES			
	ARES	No	No	-
	ARS			
	FZU	No	No	-
	FZU			
	FZV	No	No	-
	FZV			
Move Commands	SPDnnnnnn	No	Speed limit exceeded	-
	SPDnnnnnn			
	MOV(±)nnnnnnnn	No	Yes	-
	MOV(±)nnnnnnnn			
	MOVI(±)nnnnnnnn	No	Yes	-
	MVI(±)nnnnnnnn			
	ST	No	No	*
	STR			
	POS(±)nnnnnnnn	No	Stored stroke limit exceeded	*
	POS(±)nnnnnnnn			
	POSI(±)nnnnnnnn	No	Stored stroke limit exceeded	*
	POI(±)nnnnnnnn			
	EXP(±)nnnnnnnn	No	Yes	*
	EXP(±)nnnnnnnn			
EXN(±)nnnnnnnn	No	Yes	*	
EXN(±)nnnnnnnn				

3

	Command Top line: Normal Bottom line: Fixed length	ERR PN	ERR OV	ERR SN
Move Commands	JOGP	No	Speed limit exceeded	*
	JGP			
	JOGN	No	Speed limit exceeded	*
	JGN			
	JOG(±)nnnnnn	No	Speed limit exceeded	*
	JOG(±)nnnnnn			
	ZRN	No	Speed limit exceeded	*
	ZRN			
	SKIP	No	No	-
	SKP			
	HOLD	No	No	-
	HLD			

Causes of ERR SN Errors Marked with *

Move Command Top line: Normal Bottom line: Fixed length	Motor Not ON	Machine Moving	Command Exceeds Stored Stroke Limit	Overtravel Limit in Command Direction Turned OFF	STOP Signal Turned OFF	Speed Limit Exceeded	STP Signal ON
ST	Yes	Yes	Yes	Yes	Yes	Yes	No
STR							
POS	Yes	Yes	No	Yes	Yes	Yes	No
POS							
POSI	Yes	Yes	No	Yes	Yes	Yes	No
POI							
EXP	Yes	Yes	Yes	Yes	Yes	Yes	Yes
EXP							
EXN	Yes	Yes	Yes	Yes	Yes	Yes	Yes
EXN							
JOGP	Yes	Yes	Yes	Yes	Yes	No	No
JGP							

Move Command Top line: Normal Bottom line: Fixed length	Motor Not ON	Machine Moving	Command Exceeds Stored Stroke Limit	Overtravel Limit in Command Direction Turned OFF	STOP Signal Turned OFF	Speed Limit Exceeded	STP Signal ON
JOGN	Yes	Yes	Yes	Yes	Yes	No	No
JGN							
JOG	Yes	Yes	Yes	Yes	Yes	No	No
JOG							
ZRN	Yes	Yes	*1	Yes	Yes	No	*2
ZRN							

Yes: Error

No: No error

- * 1. When an incremental encoder is used, no error occurs at the first zero point return operation after the control power supply is turned ON. Errors will occur thereafter.
- * 2. Errors will occur in zero point return mode only. No error occurs under other circumstances.

Each command is explained below.

Note: Commands in fixed length mode are indicated in parentheses. A checksum must be added at the end of a command in fixed length mode. Refer to 4.3 Using Fixed Length Mode. Refer to 4.1.3 Baud Rate and Command Length Mode Settings for details on normal and fixed-length modes.

1. Commands for Basic Operation

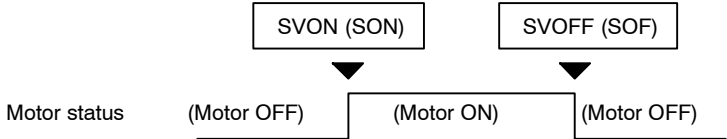
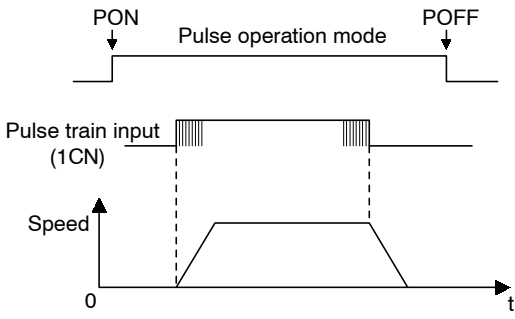
Command (): Fixed length	Function and Meaning
SVON (SON) SVOFF (SOF)	<p>SVON (SON) turns ON the motor (servo ON). SVOFF (SOF) turns OFF the motor (servo OFF). These two commands together perform the same operation as the servo ON signal /S-ON (1CN-28). In this case, the /S-ON mask bit (bit 0 of Cn-01) need not to be set.</p> 
PON (PON) POFF (POF)	<p>Turns ON or OFF pulse operation mode (positioning operation using external pulse trains). Pulse operation mode is entered for PON(PON) and canceled for POFF(POF). These two commands together perform the same operation as the pulse operation mode setting input /PULS (6CN-15).</p>  <p>Refer to 3.9 Pulse Operation Mode.</p>
PCON (PCN) PCOFF (PCF)	<p>Changes the SERVOPACK speed loop control mode between proportional/integral (PI) control and proportional (P) control. Proportional (P) control is switch to for PCON (PCN) and proportional/integral (PI) control is switch to for PCOFF (PCF). These two commands together perform the same operation as proportional operation setting input /P-CON (1CN-29).</p>

3

2. Move Commands

Command (): Fixed length	Function and Meaning
SPDnnnnnn (SPDnnnnnn) nnnnnn = 1 to 240000	<p>The feed speed will change to the first feed speed (parameter Cn-1F) when control power is turned ON or when the RES command is executed. The SPD command sets this feed speed. The units for nnnnnn are × 1000 command units/min.</p> <p>Example: For command unit = 0.01 mm and a speed command of 15m/min</p> $\frac{15000 \text{ mm/min.}}{0.01 \text{ mm}} = 1500000 \text{ command units/min}$ <p>= 1500 [× 1000 command units/min]</p> <p>Therefore, the command would be SPD1500.</p> <p>When using serial communications, the feed speeds in automatic and manual modes can be selected from three ways: Selected from 4 speeds set in parameters through contact inputs, set with digital switches, and selected from speed table through contact inputs. Refer to 3.3 <i>Feed Speed Setting in Automatic and Manual Operation Modes</i> for details on how to change the feed speed setting method.</p> <p>Note: The term “specified feed speed” in command explanations means the feed speed set in this command or in the above feed speed setting. The SPD command is used as an example of a feed speed setting method in the command explanations.</p>

3

Command (): Fixed length	Function and Meaning										
MOV ± nnnnnnnn (MOV ± nnnnnnnn) nnnnnnnn = 0 to 99999999 (+ can be omitted)	The MOV command sets a position command data. The units for ± nnnnnnnn are command units. The operation changes depending on the setting of bit 3 of Cn-26 (position command mode).										
	<table border="1"> <thead> <tr> <th data-bbox="639 485 1038 566">Memory Switch</th> <th data-bbox="1038 485 1155 566">Setting</th> <th data-bbox="1155 485 1422 566">Position Command Mode</th> </tr> </thead> <tbody> <tr> <td data-bbox="639 566 1038 612">Cn-26 Bit 3</td> <td data-bbox="1038 566 1155 612">0</td> <td data-bbox="1155 566 1422 612">Absolute</td> </tr> <tr> <td data-bbox="639 612 1038 659"></td> <td data-bbox="1038 612 1155 659">1</td> <td data-bbox="1155 612 1422 659">Incremental</td> </tr> </tbody> </table>		Memory Switch	Setting	Position Command Mode	Cn-26 Bit 3	0	Absolute		1	Incremental
Memory Switch	Setting	Position Command Mode									
Cn-26 Bit 3	0	Absolute									
	1	Incremental									
	<table border="1"> <thead> <tr> <th data-bbox="639 708 1038 757">Absolute Mode</th> <th data-bbox="1038 708 1422 757">Incremental Mode</th> </tr> </thead> <tbody> <tr> <td data-bbox="639 757 1038 804">(Data is an absolute value.)</td> <td data-bbox="1038 757 1422 804">(Data is an incremental value.)</td> </tr> <tr> <td data-bbox="639 804 1038 1208"> </td> <td data-bbox="1038 804 1422 1208"> </td> </tr> </tbody> </table>		Absolute Mode	Incremental Mode	(Data is an absolute value.)	(Data is an incremental value.)					
Absolute Mode	Incremental Mode										
(Data is an absolute value.)	(Data is an incremental value.)										
	<p>In incremental mode, the motor will rotate forward for +nnnnnnnn command value and rotate in reverse for -nnnnnnnn. The position command will be 0 when the control power supply is turned ON or when the RES command is executed.</p>										

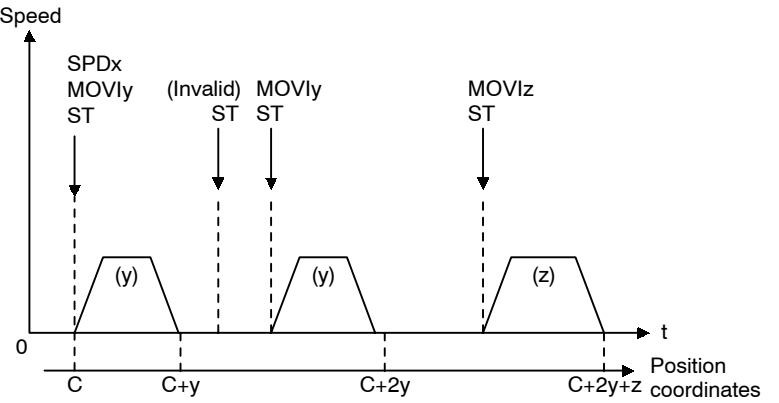
Command (): Fixed length	Function and Meaning																							
<p>MOVI ± nnnnnnnn (MVI ± nnnnnnnn) nnnnnnnn = 0 to 99999999 (+ can be omitted)</p>	<p>The MOVI (MVI) command sets an incremental position that is valid when the position command mode is set to absolute mode (when bit 3 of Cn-26 is set to 0). The data is an incremental value.</p>  <p>Note: Do not use this command in incremental position command mode (when bit 3 of Cn-26 is set to 1). The SERVOPACK will not operate correctly.</p>																							
<p>ST (STR)</p>	<p>The ST (STR) command starts automatic operation after commands have been executed to set speed and position data.</p> <p>This command is ignored during positioning.</p> <p>Example:</p> <table border="0" data-bbox="670 1095 1292 1351"> <tr> <td>1</td> <td> <table border="1" style="display: inline-table; vertical-align: middle;"> <tr><td>SPD</td><td>n...n</td></tr> <tr><td>MOV</td><td>± n...n</td></tr> <tr><td>ST</td><td></td></tr> </table> </td> <td> ... Sets speed data. ... Sets position data. ... Starts automatic operation. </td> </tr> <tr> <td>2</td> <td> <table border="1" style="display: inline-table; vertical-align: middle;"> <tr><td>MOV</td><td>± n...n</td></tr> <tr><td>ST</td><td></td></tr> </table> </td> <td> Operates at previous speed setting. </td> </tr> <tr> <td>3</td> <td> <table border="1" style="display: inline-table; vertical-align: middle;"> <tr><td>RES</td><td></td></tr> <tr><td>ST</td><td></td></tr> </table> </td> <td> Returns to zero at speed set in Cn-1F. </td> </tr> </table> <p>Note: 1. For multi-axis configurations, specify the axis when sending the ST command to check operation of a specific axis after changing parameters for that axis. If the RES command is sent to all axes or the ST command is sent without specifying an axis after tuning ON control power supply again, all axes will perform operation of example 3 shown above.</p> <p>2. If the STOP signal input (6CN-24) remains unconnected, an ERR SN (command error) will be generated when a move command is executed, even if the ST command is sent. When not using the STOP signal, set bit 0 of Cn-33 to 1 to mask the STOP signal.</p>	1	<table border="1" style="display: inline-table; vertical-align: middle;"> <tr><td>SPD</td><td>n...n</td></tr> <tr><td>MOV</td><td>± n...n</td></tr> <tr><td>ST</td><td></td></tr> </table>	SPD	n...n	MOV	± n...n	ST		... Sets speed data. ... Sets position data. ... Starts automatic operation.	2	<table border="1" style="display: inline-table; vertical-align: middle;"> <tr><td>MOV</td><td>± n...n</td></tr> <tr><td>ST</td><td></td></tr> </table>	MOV	± n...n	ST		Operates at previous speed setting.	3	<table border="1" style="display: inline-table; vertical-align: middle;"> <tr><td>RES</td><td></td></tr> <tr><td>ST</td><td></td></tr> </table>	RES		ST		Returns to zero at speed set in Cn-1F.
1	<table border="1" style="display: inline-table; vertical-align: middle;"> <tr><td>SPD</td><td>n...n</td></tr> <tr><td>MOV</td><td>± n...n</td></tr> <tr><td>ST</td><td></td></tr> </table>	SPD	n...n	MOV	± n...n	ST		... Sets speed data. ... Sets position data. ... Starts automatic operation.																
SPD	n...n																							
MOV	± n...n																							
ST																								
2	<table border="1" style="display: inline-table; vertical-align: middle;"> <tr><td>MOV</td><td>± n...n</td></tr> <tr><td>ST</td><td></td></tr> </table>	MOV	± n...n	ST		Operates at previous speed setting.																		
MOV	± n...n																							
ST																								
3	<table border="1" style="display: inline-table; vertical-align: middle;"> <tr><td>RES</td><td></td></tr> <tr><td>ST</td><td></td></tr> </table>	RES		ST		Returns to zero at speed set in Cn-1F.																		
RES																								
ST																								

3

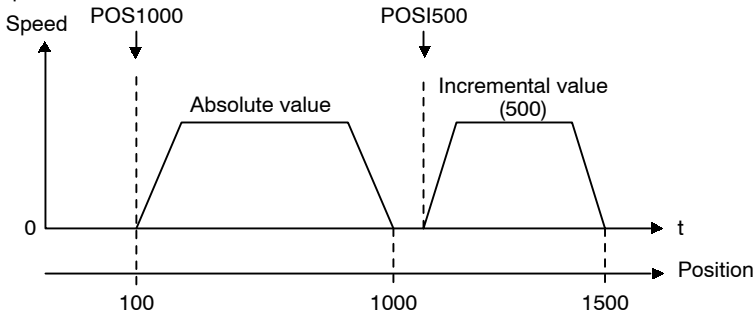
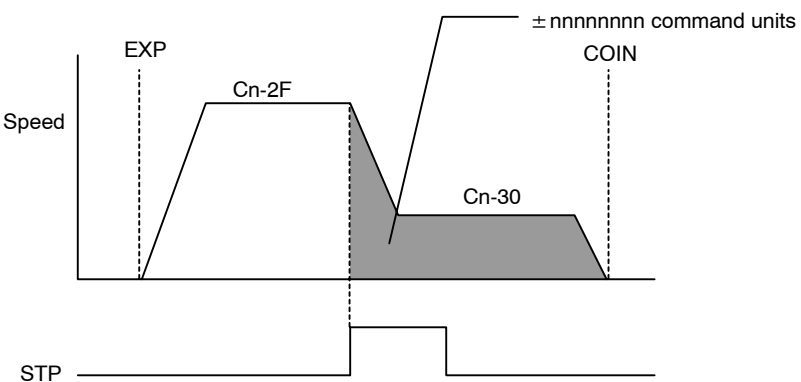
Command (): Fixed length	Function and Meaning
<p>POS ± nnnnnnnn (POS ± nnnnnnnn)</p> <p>POSI ± nnnnnnnn (POI ± nnnnnnnn)</p> <p>nnnnnnnn = 0 to 99999999</p> <p>(+ can be omitted)</p>	<p>The POS or POSI (POI) command performs positioning in linear acceleration/deceleration mode. The first feed speed (Cn-1F) will be used.</p> <p>For POS: Performs positioning to an absolute value of ± nnnnnnnn.</p> <p>For POSI: Performs positioning to an incremental value of ± nnnnnnnn from the current position.</p> <p>Example:</p>  <p>Note: These commands are not affected by the position command mode (bit 3 of Cn-26).</p>
<p>EXP ± nnnnnnnn (EXP ± nnnnnnnn)</p> <p>nnnnnnnn = 0 to 99999999</p> <p>(+ can be omitted)</p>	<p>Cn-32 bit F must be set to 1 to use the EXP command. The EXP command starts forward rotation for external positioning operation.</p> <p>The EXP command is not valid if Cn-32 bit F is set to 0.</p> <p>When this command is received, the motor will start forward rotation at the speed specified in Cn-2F. When the STP signal goes from low to high, the motor will move to the position of ± nnnnnnnn command units at the speed specified in Cn-30. If the sign of the movement amount is negative, the motor will decelerate to a stop and then move in reverse to the specified position.</p> 

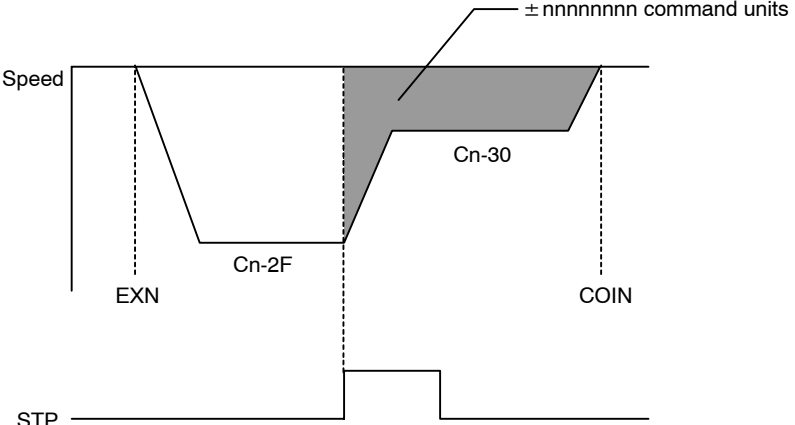
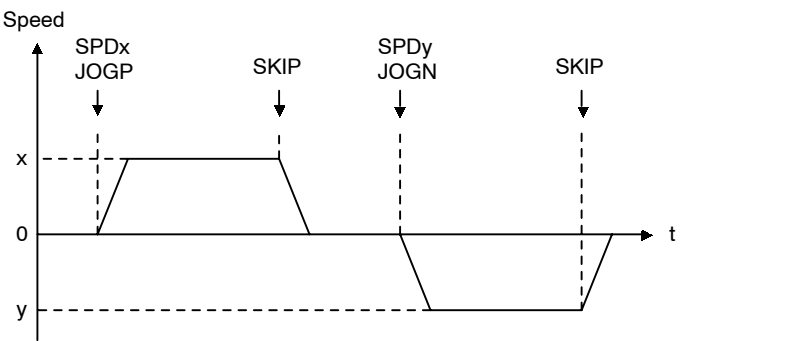
Command (): Fixed length	Function and Meaning
<p>EXN ± nnnnnnnn (EXN ± nnnnnnnn)</p> <p>nnnnnnnn = 0 to 99999999</p> <p>(+ can be omitted)</p>	<p>Cn-32 bit F must be set to 1 to use the EXN command. The EXN command starts reverse rotation for external positioning operation.</p> <p>The EXN command is not valid if Cn-32 bit F is set to 0.</p> <p>When this command is received, the motor will start reverse rotation at the speed specified in Cn-2F. When the STP signal goes from low to high, the motor will move to the position of ± nnnnnnnn command units at the speed specified in Cn-30. If the sign of the movement amount is positive, the motor will decelerate to a stop and then move forward to the specified position.</p> 
<p>JOGP (JGP)</p> <p>JOGN (JGN)</p>	<p>The JOGP (JGP) or JOGN (JGN) command starts constant-speed motor operation at the feed speed specified in CN32 of Cn-18.</p> <p>JOGP (JGP) is the forward command. JOGN (JGN) is the reverse command. The SKIP (SKP) command is used to stop the motor.</p>  <p>Note: When this command is used, there is no need to set manual operation mode.</p>

3

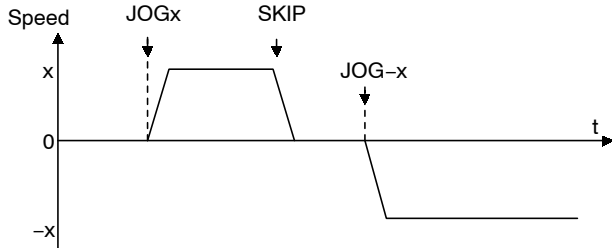
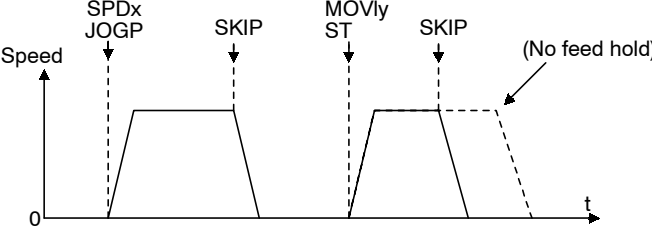
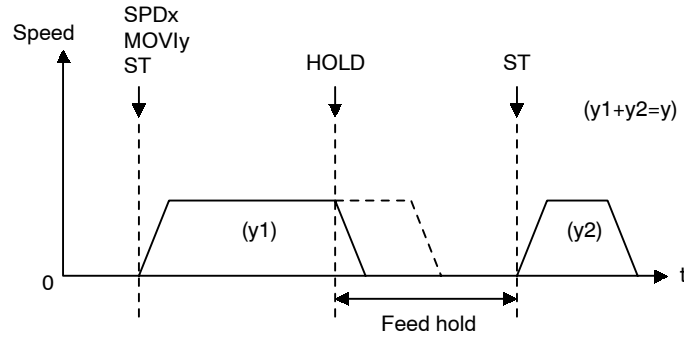
Command (): Fixed length	Function and Meaning
<p>JOG ± nnnnnn (JOG ± nnnnnn)</p> <p>nnnnnn = 1 to 240000 (+ can be omitted)</p>	<p>The JOG command starts manual operation at a speed of ± nnnnnn. The SKIP (SKP) command is used to stop the motor.</p>  <p>Note: When this command is used, there is no need to set manual operation mode.</p>
<p>SKIP (SKP)</p>	<p>The SKIP (SKP) command stops operation at the specified deceleration rate (set in a parameter.)</p>  <p>Note: This command has no feed hold function.</p>
<p>HOLD (HLD)</p>	<p>If the HOLD command is sent during positioning using the ST command, the motor will stop at the specified deceleration rate but the remaining movement will be retained (feed hold function).</p> <p>Note: There is no feed hold function if bit 1 of Cn-33 is set to 1.</p> 

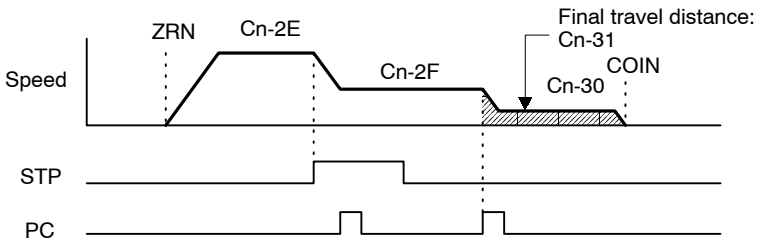
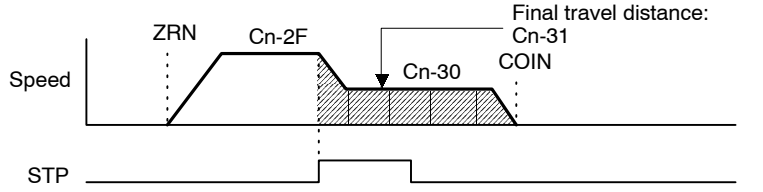
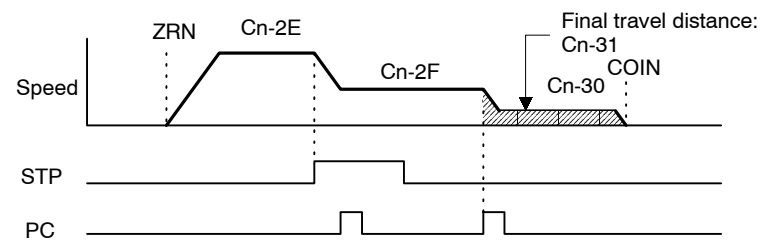
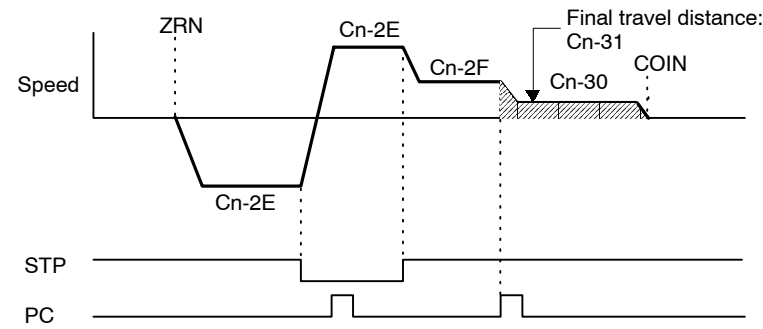
Command (): Fixed length	Function and Meaning
<p>ZRN (ZRN)</p>	<p>The ZRN command starts one of the the machine zero point return operations shown below.</p> <p>Note: When this command is used, there is no need to set the machine zero point return mode.</p> <ul style="list-style-type: none"> <p>Mode I (bit 3 and bit 2 of Cn-29 both set to 0) Mode 1 uses a 3-step deceleration method using the STP signal (used as a deceleration limit switch) and phase-C pulse.</p>  <p>Mode II (bit 3 and bit 2 of Cn-29 set to 0 and 1, respectively) Mode II uses a 2-step deceleration method using the STP signal (used as a stop limit switch).</p>  <p>Mode III (bit 3 and bit 2 of Cn-29 both set to 1) Mode III uses a 3-step deceleration method with the STP signal as a deceleration limit switch and with a phase-C pulse. The STP signal starts at the Close (L) level</p>  <p>The STP signal starts at the Open (H) level</p> 

3

Command	Function and meaning																																																																												
	<p>Note: The ZRN command is effective only when bit 0 of Cn-29 is set to 1.</p> <p>Parameters and memory switch bits for machine zero point return are listed in the following table.</p> <table border="1" data-bbox="625 406 1422 1140"> <thead> <tr> <th data-bbox="625 406 823 453">Number</th> <th data-bbox="823 406 1050 453">Name</th> <th colspan="4" data-bbox="1050 406 1281 453">Setting Range</th> <th colspan="2" data-bbox="1281 406 1422 453">Unit</th> </tr> </thead> <tbody> <tr> <td data-bbox="625 453 823 534">Cn-29 Bit 0</td> <td data-bbox="823 453 1050 534">Machine zero point return</td> <td colspan="6" data-bbox="1050 453 1422 534">0: Not used 1: Used</td> </tr> <tr> <td data-bbox="625 534 823 580">Cn-29 Bit 2</td> <td data-bbox="823 534 1050 629" rowspan="2">Machine zero point return mode</td> <td data-bbox="1050 534 1090 580">0</td> <td data-bbox="1090 534 1161 580">Mode I</td> <td data-bbox="1161 534 1201 580">1</td> <td data-bbox="1201 534 1281 580">Mode II</td> <td data-bbox="1281 534 1321 580">1</td> <td data-bbox="1321 534 1422 580">Mode III</td> </tr> <tr> <td data-bbox="625 580 823 629">Cn-29 Bit 3</td> <td data-bbox="1050 580 1090 629">0</td> <td data-bbox="1090 580 1161 629"></td> <td data-bbox="1161 580 1201 629">0</td> <td data-bbox="1201 580 1281 629"></td> <td data-bbox="1281 580 1321 629">1</td> <td data-bbox="1321 580 1422 629"></td> </tr> <tr> <td data-bbox="625 629 823 710">Cn-29 Bit 4</td> <td data-bbox="823 629 1050 710">Machine zero point return direction</td> <td colspan="6" data-bbox="1050 629 1422 710">0: Forward rotation 1: Reverse rotation</td> </tr> <tr> <td data-bbox="625 710 823 791">Cn-2E</td> <td data-bbox="823 710 1050 791">Machine zero point return feed speed</td> <td colspan="5" data-bbox="1050 710 1281 791">1 to 240000</td> <td colspan="2" data-bbox="1281 710 1422 981" rowspan="3">× 1000 command units/min.</td> </tr> <tr> <td data-bbox="625 791 823 902">Cn-2F</td> <td data-bbox="823 791 1050 902">Machine zero point return approach speed</td> <td colspan="5" data-bbox="1050 791 1281 902">1 to 240000</td> </tr> <tr> <td data-bbox="625 902 823 981">Cn-30</td> <td data-bbox="823 902 1050 981">Machine zero point return creep speed</td> <td colspan="5" data-bbox="1050 902 1281 981">1 to 240000</td> </tr> <tr> <td data-bbox="625 981 823 1140" rowspan="2">Cn-31</td> <td data-bbox="823 981 1050 1064" rowspan="2">Machine zero point return final travel distance</td> <td colspan="5" data-bbox="1050 981 1281 1064">Forward rotation: 0 to +9999999</td> <td colspan="2" data-bbox="1281 981 1422 1140" rowspan="2">Command unit</td> </tr> <tr> <td colspan="5" data-bbox="1050 1064 1281 1140">Reverse rotation: -9999999 to 0</td> </tr> </tbody> </table> <p data-bbox="612 1198 1082 1225">Refer to 3.10 Machine Zero Point Return Mode.</p>	Number	Name	Setting Range				Unit		Cn-29 Bit 0	Machine zero point return	0: Not used 1: Used						Cn-29 Bit 2	Machine zero point return mode	0	Mode I	1	Mode II	1	Mode III	Cn-29 Bit 3	0		0		1		Cn-29 Bit 4	Machine zero point return direction	0: Forward rotation 1: Reverse rotation						Cn-2E	Machine zero point return feed speed	1 to 240000					× 1000 command units/min.		Cn-2F	Machine zero point return approach speed	1 to 240000					Cn-30	Machine zero point return creep speed	1 to 240000					Cn-31	Machine zero point return final travel distance	Forward rotation: 0 to +9999999					Command unit		Reverse rotation: -9999999 to 0				
Number	Name	Setting Range				Unit																																																																							
Cn-29 Bit 0	Machine zero point return	0: Not used 1: Used																																																																											
Cn-29 Bit 2	Machine zero point return mode	0	Mode I	1	Mode II	1	Mode III																																																																						
Cn-29 Bit 3		0		0		1																																																																							
Cn-29 Bit 4	Machine zero point return direction	0: Forward rotation 1: Reverse rotation																																																																											
Cn-2E	Machine zero point return feed speed	1 to 240000					× 1000 command units/min.																																																																						
Cn-2F	Machine zero point return approach speed	1 to 240000																																																																											
Cn-30	Machine zero point return creep speed	1 to 240000																																																																											
Cn-31	Machine zero point return final travel distance	Forward rotation: 0 to +9999999					Command unit																																																																						
		Reverse rotation: -9999999 to 0																																																																											
ZEROSSET ± nnnnnnnn (ZST ± nnnnnnnn)	<p>The ZEROSSET command sets the machine zero point so that the current position is ± nnnnnnnn.</p> <p>The setting made by the ZEROSSET command is made effective by executing the RES command or cycling the control power supply.</p> <p>Note: The current position is the value given by PUN = ± nnnnnnnn sent for the MONF command.</p>																																																																												
SET ± nnnnnnnn (SET ± nnnnnnnn)	<p>The SET command sets a working zero point so that the current position is ± nnnnnnnn. The working zero point is a temporary zero point offset from the machine zero point.</p> <p>The setting made by the SET command is effective as soon as the command is executed..</p> <p>The zero point set by the SET command will be initialized and the original zero point will be set again when the CLR command or the RES command is executed or the control power supply is cycled.</p>																																																																												
CLR (CLR)	Sets the zero point offset made by the SET command to 0, and then sets the zero point again as the machine zero point.																																																																												
RES (RES)	Performs the same operation as if manually turning the control power supply OFF and then ON again.																																																																												

Command	Function and meaning
ARES (ARS)	Clears the alarm and then resets the status of the machine to normal operation.
FZU (FZU)	For manual adjustment of the U-phase current offset. Example: Command Response from SERVOPACK FZU FZU = +nn
FZU = +nn (FZU = +nn) nn = +0 to 99 (Mark + can be omitted.)	Rewrites the U-phase current offset as the + nn. The plus sign, (+), can be omitted. Enabled on-line, so the execution of the [RES] command and the force resetting of the control power supply are not necessary.
FZV (FZV)	For manual adjustment of the V-phase current offset. Example: Command Response from SERVOPACK FZV FZV = +nn
FZV = +nn (FZV = +nn) nn = +0 to 99 (Mark + can be omitted.)	Rewrites V-phase current offset as the + nn. The plus sign, (+), can be omitted. Enabled on-line, so the execution of the [RES] command and force resetting of the control power supply are not necessary.

3.7 Automatic Mode: Command Table

This section explains how to operate the motor in automatic mode using the command table (parameter Cn-27 set to 4).

The command table method can be used to write a maximum of 512 positions to a position table and a maximum of 512 speeds to a speed table to SERVOPACK memory beforehand, and then perform positioning to table positions specified using contact commands. The feed speed will normally be the speed set in the speed table with the same number as the position selected in the position table.

Position and speed table data is set using serial communications or the Digital Operator. Refer to *Chapter 4 Using Serial Communications* or *Chapter 5 Using the Digital Operator* for the setting methods.

The following diagram shows 1CN and 6CN wiring for using command tables.

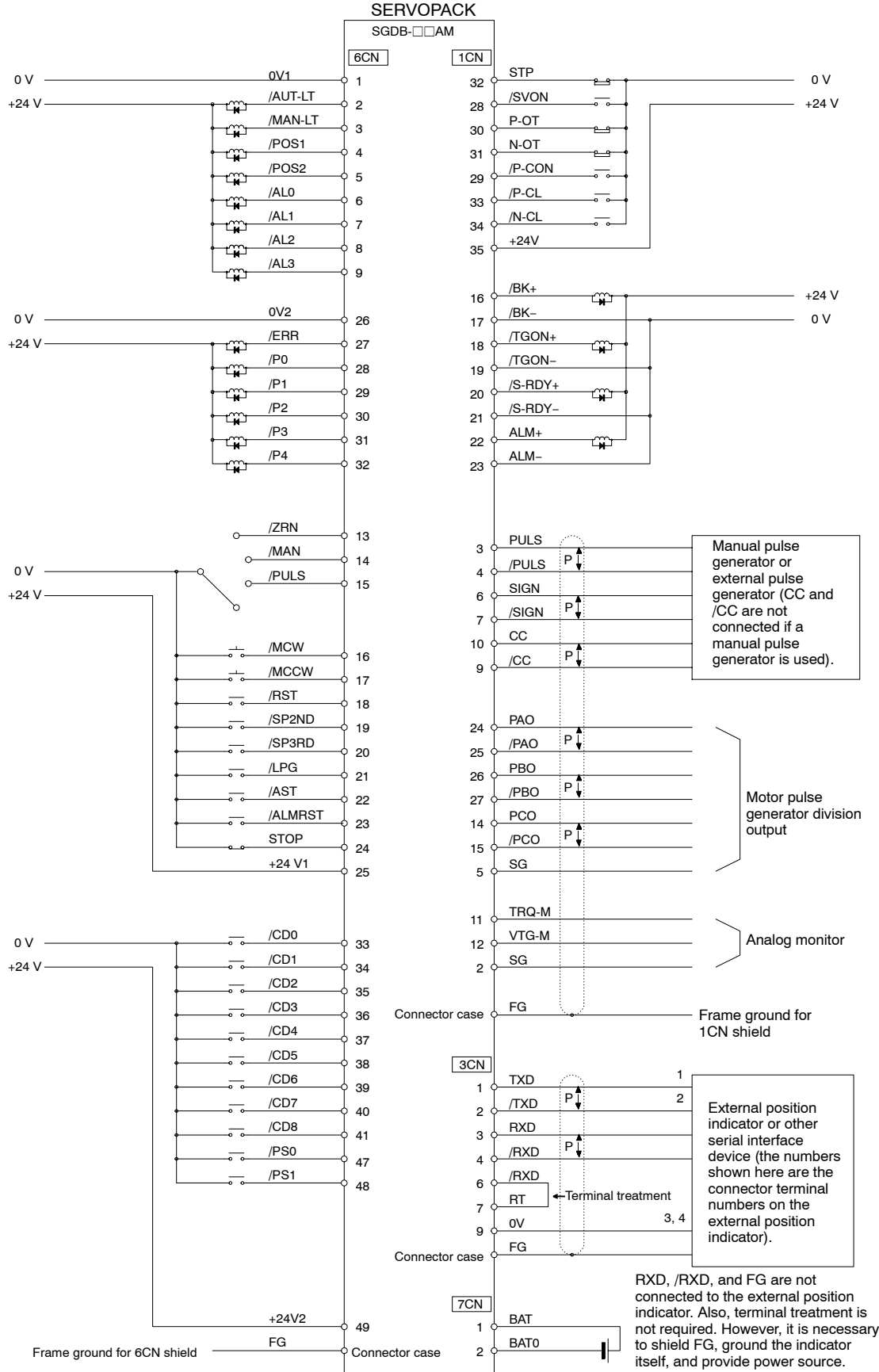

The I/O signals used with a command table are outlined below. Refer to 3.2 *Signals Common to All Modes* for details on signals not listed here.

3.7.1 Data Number Input Signals

The contact data input signals that specify the data numbers in the position and speed tables are listed below.

→ Input /CD0 6CN-33	Data Number Command Input
→ Input /CD1 6CN-34	Data Number Command Input
→ Input /CD2 6CN-35	Data Number Command Input
→ Input /CD3 6CN-36	Data Number Command Input
→ Input /CD4 6CN-37	Data Number Command Input
→ Input /CD5 6CN-38	Data Number Command Input
→ Input /CD6 6CN-39	Data Number Command Input
→ Input /CD7 6CN-40	Data Number Command Input
→ Input /CD8 6CN-41	Data Number Command Input

Set the position data code to binary using the following memory switch bit.

Cn-26 Bit 4	Position Data Code	Factory Setting: 0
--------------------	--------------------	--------------------

Setting	Meaning
0	Binary
1	BCD (binary coded decimal)

Set this bit to 0 when using the command table. The SERVOPACK will not operate normally if this bit is set to 1.

The following table shows the command data codes for each contact.

Input Signal	/CD0	/CD1	/CD2	/CD3	/CD4	/CD5	/CD6	/CD7	/CD8
Data Code	1	2	4	8	16	32	64	128	256

The number selected in the table will be the sum of the signal codes for the closed contacts (at low level) from CD0 to CD8.

Example: If CD0, CD5, and CD8 are closed, the number selected in the table = 1 + 32 + 256 = 289.

Select the position command mode (absolute or incremental) using the following memory switch bit.

Cn-26 Bit 3	Position Command Mode	Factory Setting: 0
--------------------	-----------------------	--------------------

Setting	Meaning
0	Absolute
1	Incremental

In absolute position command mode, positioning will be performed to the position specified in the table. In incremental position command mode, positioning will be performed to the position of the current stop position + position specified in the table.

3.7.2 Zone Signal Outputs

A 511-point zone signal boundary position table is written to the SERVOPACK memory and zone data for the current motor position is output.

Data for the zone signal boundary position table can be set using serial communications or the Digital Operator. Refer to *4 Using Serial Communications* or *Chapter 5 Using the Digital Operator* for the setting methods.

Set the following memory switch bit to use zone signals.

Cn-33 Bit A	Zone Signal	Factory Setting: 0
--------------------	-------------	--------------------

Setting	Meaning
0	Does not use zone signal.
1	Uses zone signal.

→ Input /PS0 6CN-47	Zone Signal Read Selection
→ Input /PS1 6CN-48	Zone Signal Read Selection

Output → /P0 6CN-28	Zone Signal Data Output
Output → /P1 6CN-29	Zone Signal Data Output
Output → /P2 6CN-30	Zone Signal Data Output
Output → /P3 6CN-31	Zone Signal Data Output
Output → /P4 6CN-32	Zone Signal Data Output

Zone data for the current motor position is read using zone signal data outputs (/P0 to /P4). Because /P0 to /P4 have only 5 bits, switch the digit by using zone data read selection signals /PS0 and /PS1 and read the zone data in order. The following table shows the different codes for output signals /P0 to /P4 depending on the combinations of open and closed settings for /PS0 and /PS1. The sum of the codes for signals /P0 to /P4 that are closed (at low level) will be the zone data of the current position.

Input Signal Output Signal	/PS0	Open (High Level)	Closed (Low Level)	Open (High Level)	Closed (Low Level)
	/PS1	Open (High Level)	Open (High Level)	Closed (Low Level)	Closed (Low Level)
Binary Setting Cn-26 Bit 4 = 0	/P0	1	1	16	256
	/P1	2	2	32	512
	/P2	4	4	64	1024
	/P3	8	8	128	2048
	/P4	16	Odd parity	Odd parity	Odd parity
BCD Setting Cn-26 Bit 4 = 1	/P0	1	1	10	100
	/P1	2	2	20	200
	/P2	4	4	40	400
	/P3	8	8	80	800
	/P4	10	Odd parity	Odd parity	Odd parity

Note: 1. When /PS0 and /PS1 are at high level, /P4 becomes a parity bit. For example, in BCD notation, if the value for /P0 to /P3 is 7 when /PS0 is at low level and /PS1 is at high level, /P4 will be set at high level so that the total number of signals at low levels is odd (in this example, 3: /P0 = low, /P1 = low, /P2 = low, and /P3 = high).

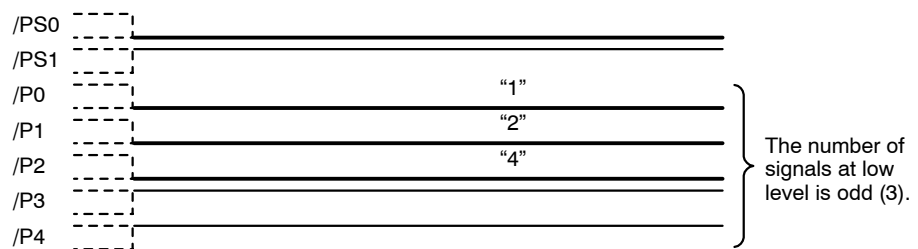

2. When reading zone data separately over several reads, set the read timing as follows:

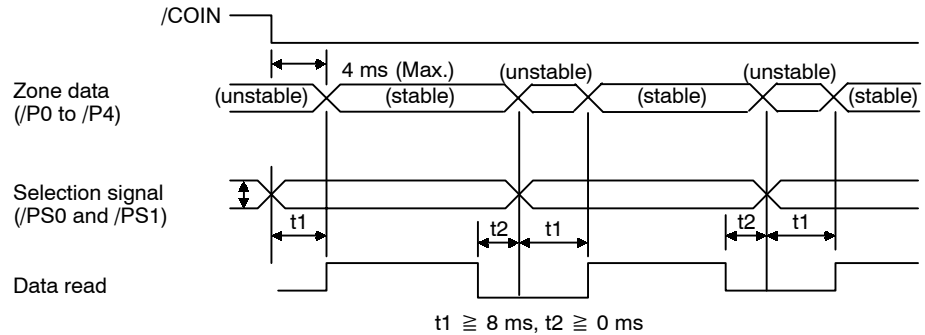

When using the command table, set the following memory switch bit to output digits /P5 to /P8 of the zone signal data outputs to 6CN-6, -7, -8, and -9. In this case, alarm and error code outputs (/AL0 to /AL3) cannot be used.

Cn-33 Bit 5	Station Number Output Expansion	Factory Setting: 0
--------------------	---------------------------------	--------------------

3

Setting	Meaning
0	Outputs alarm and error codes (/AL0 to /AL3) to 6CN-6 to 6CN-9.
1	Outputs digits /P5 to /P8 of current position station numbers to 6CN-6 to 6CN-9.

The codes for signals /P5 to /P8 are shown in the following table.

Binary Setting Cn-26 Bit 4 = 0	/P5	32
	/P6	64
	/P7	128
	/P8	256
BCD Setting Cn-26 Bit 4 = 1	/P5	20
	/P6	40
	/P7	80
	/P8	100

Note: 1. /P5 to /P8 signal codes do not change according to /PS0 and /PS1 signals.

- Zone signals are output as codes as shown in the following diagram when /PS0 and /PS1 are at low level. Unless the motor is stopped, data may not be read correctly due to code output.

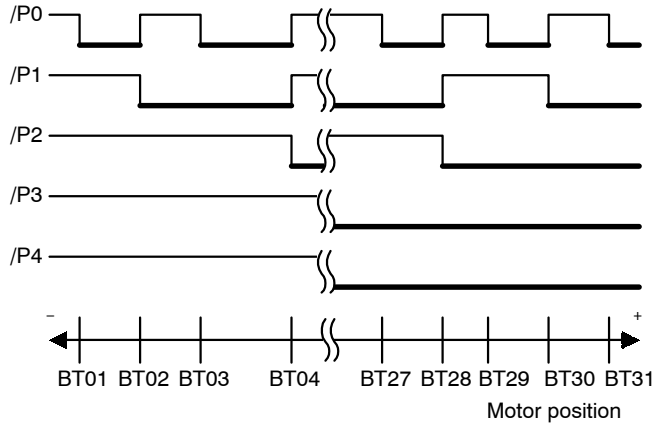

- Up to 40 ms is required from when the motor position boundary is passed until the zone signal is changed.
- The zone signal boundary positions in the table must be arranged as shown in the above diagram. Even if there are less than 511 boundary positions to be set, be sure to arrange the boundary positions in order from BT01 to BT511. BTn setting value $\leq BTn+1$.

Example: When using only BT01 to BT20, set $BT21 = BT22 = \dots = BT511 = +99999999$.

3.7.3 Speed Command Input

When using the command table method, the factory setting for the speed command method is to select from the speed table through contact inputs. In this method, a table containing up to 512 pairs of positions and speeds will be set, and the motor will be operated using the position command from the position table location selected by table command data /CD0 to /CD8 as well as the speed command from the speed at the location selected in the table.

Speed table data is set using serial communications or the Digital Operator. Refer to *Chapter 4 Using Serial Communications* or *Chapter 5 Using the Digital Operator* for the setting methods.

When using the command table method, the feed speed in automatic and manual operation modes can be set to be selected from 4 speeds set in parameters through contact inputs or to be set in the SPD serial command. Refer to *3.3 Feed Speed Setting in Automatic and Manual Operation Modes* for details on how to change the feed speed setting method.

3.8 Manual Mode

This section explains motor operation in manual operation mode using I/O signals.

In manual operation mode, the motor is operated at the specified speed only while manual operation signals /MCCW or /MCW are active.

To select manual operation mode, activate the manual operation mode selection input signal /MAN. Refer to 3.2.4 *Operation Mode Selection*.

Start and stop manual operation mode using the following input signals.

→ Input /MCCW 6CN-13	Manual Forward Rotation Command
→ Input /MCW 6CN-14	Manual Reverse Rotation Command

3

The factory-set feed speed setting method for manual operation differs according to the position command method in automatic mode (set at parameter Cn-27) as shown in the following table. Refer to information on the individual operating methods for automatic mode for details on feed speed setting methods.

Cn-27 Setting	Position Command Method in Automatic Mode	Feed Speed Setting Method
0	Station numbers	Select from 4 speeds set in parameter through contact input.
1	Digital switches	Set with digital switches.
2	Serial communications	Set in SPD serial command.
4	Command table	Select from speed table through contact input.

Refer to 3.3 *Feed Speed Setting in Automatic and Manual Operation Modes* for details on how to change the feed speed setting method in manual operation mode.

Refer to 3.1.6 *Setting the Acceleration/Deceleration Type and Rate* for details on acceleration/deceleration types and speeds in manual operation mode.

3.9 Pulse Operation Mode

This section explains motor operation in pulse operation mode.

In pulse operation mode, the motor is operated in accordance with input command pulses.

Activate the pulse operation mode selection input signal /PULS to select the pulse operation mode. Refer to 3.2.4 Operation Mode Selection.

- Note: 1. Pulse operation mode and line pulse generators cannot be used at the same time.
- 2. During pulse operation mode, designation of the speed limit and the acceleration/ deceleration type is made unavailable.

■ Commands Using Pulse Inputs

Move commands can be given using pulse inputs.

Only line driver output can be wired.

3

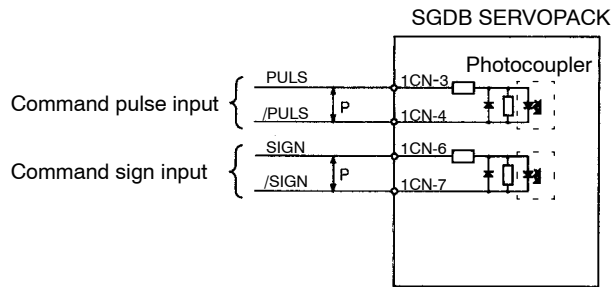

↑↓:P: Indicates twisted-pair cables.

Wiring Example

Applicable Line Driver:

SN75174 or MC3487 manufactured by TI or equivalent

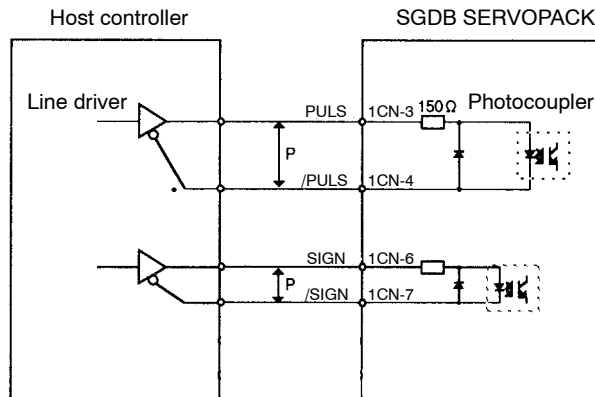

■ Command Pulse Form Selection

Select the command pulse form using the following memory switch.

→ Input PULS 1CN-3	Command Pulse Input
→ Input /PULS 1CN-4	Command Pulse Input
→ Input SIGN 1CN-6	Command Sign Input
→ Input /SIGN 1CN-7	Command Sign Input

The motor only rotates at an angle proportional to the input pulse.

Cn-02 Bit 3	Command Pulse Form Selection	Factory Setting: 0
Cn-02 Bit 4	Command Pulse Form Selection	Factory Setting: 0
Cn-02 Bit 5	Command Pulse Form Selection	Factory Setting: 0

Set the command pulse form for externally input command pulses.

Set in accordance with host controller specifications.

The input pulse logic can be set in bit D of Cn-02 and this should be set at the same time.

- Note: 1. One pulse command input is equivalent to motor travel distance of one command unit.
Refer to 3.1.5 *Electronic Gear* for information on command units. (P pulses → P command units)
2. The feed speed is specified as pulse frequency. (f (pps) → $f \times 60$ command units/min)
3. In pulse operation mode, speed selection signals /SP2ND (6CN-19) and /SP3RD (6CN-20) are used to set the input pulse multiplication.

SP2ND	SP3RD	Pulse Multiplication
Open (high)	Open (high)	× 1
Closed (low)	Open (high)	× 10
Open (high)	Closed (low)	× 100
Closed (low)	Closed (low)	× 1

3

Cn-02				Input Pulse Multiplication	Command Pulse Form	Motor Forward Run Command	Motor Reverse Run Command
Bit D	Bit 5	Bit 4	Bit 3				
0 (Positive logic setting)	0	0	0	–	Sign + pulse train	PULS (1CN-3) SIGN (1CN-6) "H"	PULS (1CN-3) SIGN (1CN-6) "L"
	0	1	0	× 1	Two-phase pulse train with 90° phase difference	PULS (1CN-3) SIGN (1CN-6)	PULS (1CN-3) SIGN (1CN-6)
	0	1	1	× 2			
	1	0	0	× 4			
	0	0	1	–	CW pulse + CCW pulse	PULS (1CN-3) SIGN (1CN-6)	PULS (1CN-3) SIGN (1CN-6) "L"
1 (Negative logic setting)	0	0	0	–	Sign + pulse train	PULS (1CN-3) SIGN (1CN-6) "L"	PULS (1CN-3) SIGN (1CN-6) "H"
	0	1	0	× 1	Two-phase pulse trains with 90° phase difference	PULS (1CN-3) SIGN (1CN-6)	PULS (1CN-3) SIGN (1CN-6)
	0	1	1	× 2			
	1	0	0	× 4			
	0	0	1	–	CW pulse + CCW pulse	PULS (1CN-3) SIGN (1CN-6)	PULS (1CN-3) SIGN (1CN-6) "H"

Input Pulse Multiply Function

When the command pulse form is two-phase pulse train with 90° phase difference, the input pulse multiply function can be used.

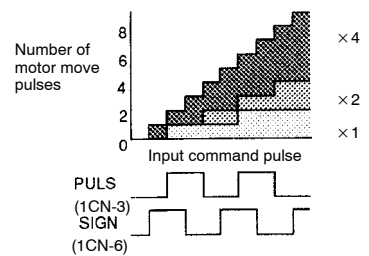

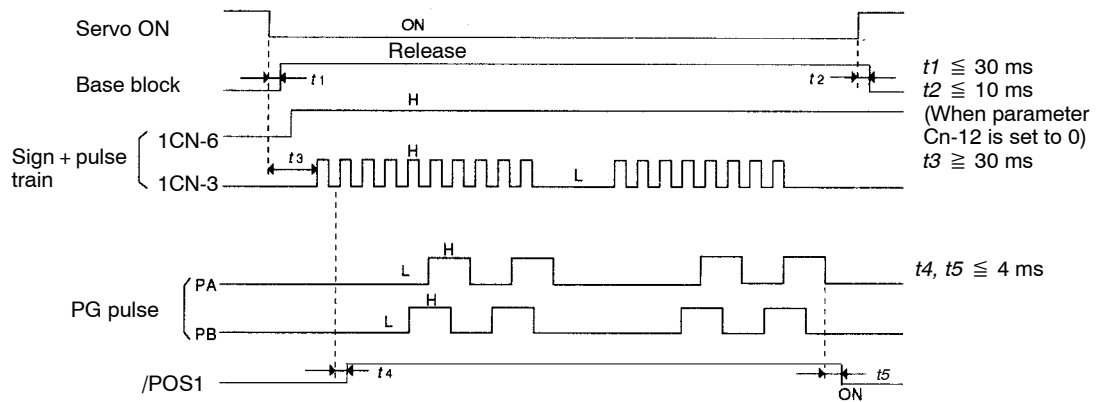

Note: The interval from the time the servo ON signal is turned ON until a command pulse is input must be at least 30 ms. Otherwise, the command pulse may not be input.

Figure 3.1 Example of I/O Signal Generation Timing

Table 3.1 Allowable Voltage Level and Timing for Command Pulse Input

Command Pulse Signal Form	Electrical Specifications	Remarks
Sign + pulse train input (SIGN + PULS signal) Maximum command frequency: 450 kpps	<p> $t_1, t_2 \leq 0.1 \mu s$ $r \geq 1.1 \mu s$ $t_3, t_7 \leq 0.1 \mu s$ $t_4, t_5, t_6 > 3 \mu s$ </p>	The signs for each command pulse are as follows: \oplus : High level \ominus : Low level
Two-phase pulse train with 90° phase difference (phase A + phase B) Maximum command frequency × 1 multiplier: 450 kpps × 2 multiplier: 400 kpps × 4 multiplier: 200 kpps	<p> Phase B is 90° forward from phase A. Phase B is 90° behind phase A. $t_1, t_2 \leq 0.1 \mu s$ $r \geq 1.1 \mu s$ $\frac{r}{T} \times 100 \leq 50\%$ </p>	Parameter Cn-02 (bits 3, 4 and 5) is used to switch the input pulse multiplier mode.
CCW pulse + CW pulse Maximum command frequency: 450 kpps	<p> $t_1, t_2 \leq 0.1 \mu s$ $r \geq 1.1 \mu s$ $t_3 > 3 \mu s$ $\frac{r}{T} \times 100 \leq 50\%$ </p>	—

3.10 Machine Zero Point Return Mode

This section explains how to operate the motor in machine zero point return mode.

In machine zero point return mode, positioning is performed using the machine zero point return limit switch to determine the machine zero point of the machine. This mode is mainly used immediately after the power is turned ON when using an incremental encoder.

To select machine zero point return mode, activate the machine zero point return mode selection signal /ZRN. Refer to 3.2.4 *Operation Mode Selection*.

Set the following parameters to use machine zero point return mode.

Cn-29 Bit 0	Machine Zero Point Return Mode	Factory Setting: 0
--------------------	--------------------------------	--------------------

Setting	Meaning
0	Do not use machine zero point return mode.
1	Use machine zero point return mode.

Cn-29 Bit 2	Machine Zero Point Return Mode Selection	Factory Setting: 1
Cn-29 Bit 3	Machine Zero Point Return Mode Selection	Factory Setting: 0

Setting		Meaning
Bit 3	Bit 2	
0	0	Mode I
0	1	Mode II
1	1	Mode III

Cn-29 Bit 4	Machine Zero Point Return Direction	Factory Setting: 0
--------------------	-------------------------------------	--------------------

Setting	Meaning
0	Forward
1	Reverse

Cn-2E	Machine Zero Point Return Feed Speed	Unit: ×1000 Command Units/min	Setting Range: 1 to 240000	Factory Setting: 200
--------------	--------------------------------------	----------------------------------	-------------------------------	-------------------------

Cn-2F	Machine Zero Point Return Approach Speed	Unit: ×1000 Command Units/min	Setting Range: 1 to 240000	Factory Setting: 100
--------------	--	----------------------------------	-------------------------------	-------------------------

Cn-30	Machine Zero Point Return Creep Speed	Unit: ×1000 Command Units/min	Setting Range: 1 to 240000	Factory Setting: 50
Cn-31	Machine Zero Point Return Final Travel Distance	Unit: Command Units	Setting Range: -99999999 to +99999999	Factory Setting: 8192

3.10.1 Machine Zero Point Return Mode I (Bits 2 and 3 of Cn-29 Set to 0)

Machine Zero point return mode I is a 3-step deceleration method using the STP signal (as a deceleration limit switch) and phase-C pulse. When the STP signal status changes from closed (low level) to open (high level), the load will decelerate from the machine zero point return feed speed (set in Cn-2E) to the machine zero point return approach speed (set in Cn-2F). The load will then pass the machine zero point limit switch and once the STP signal changes from open (high level) to closed (low level), and the load will reach the machine zero point return creep speed (set in Cn-30) at the initial phase-C pulse. The load will then move the machine zero point return final travel distance from the point of the phase-C pulse, and stop.

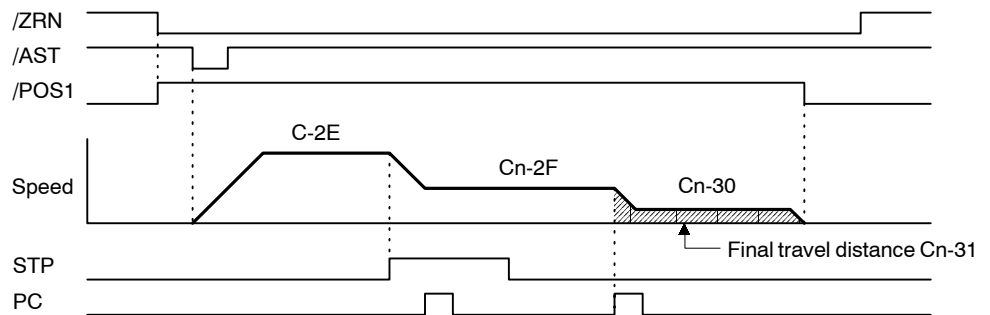

If the STP signal is open (high level) when the machine zero point return operation is started, the machine zero point return will be started at the machine zero point return approach speed (Cn-2F).

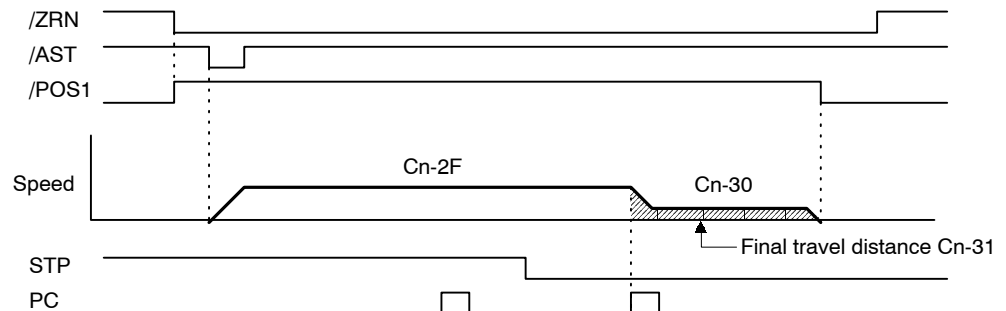

3.10.2 Machine Zero Point Return Mode II (Bits 2 and 3 of Cn-29 Set to 1 and 0 Respectively)

Machine zero point return mode II is a 2-step deceleration method that uses the STP signal as a stop limit switch. When the STP signal changes from closed (low level) to open (high level), the load travel speed will change from the machine zero point return approach speed (set in Cn-2F) to the machine zero point return creep speed (set in Cn-30). The load will travel the machine zero point return final travel distance (set in Cn-31) and stop.

If the STP signal is open (high level) at the start of the machine zero point return operation a position error will occur.

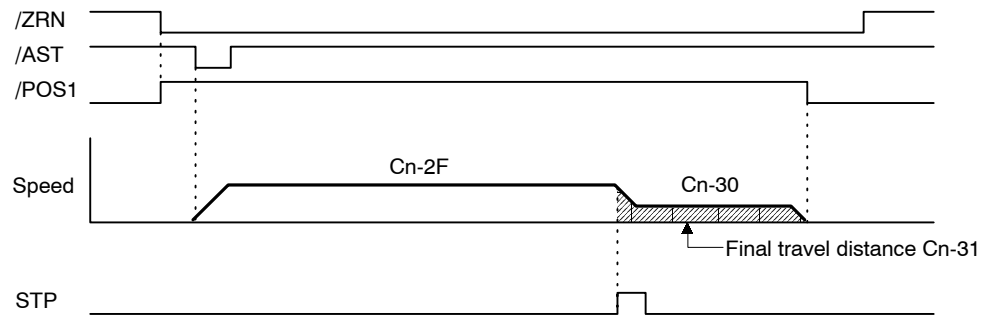

3.10.3 Machine Zero Point Return Mode III (Bits 2 and 3 of Cn-29 Set to 1)

Machine zero point return mode III is a 3-step deceleration method that uses the STP signal as a deceleration limit switch and phase-C pulse.

If the STP signal is open (at high level) at the start of the machine zero point return operation, the load will decelerate from the machine zero point return feed speed (set in Cn-2E) to the machine zero point return approach speed (set in Cn-2F). When the STP signal changes from open (at high level) to closed (low level), the load will decelerate to the machine zero point return creep speed (set in Cn-30) at the initial phase-C pulse, and move the machine zero point return final travel distance (set in Cn-31) from the point of the phase-C pulse, and stop.

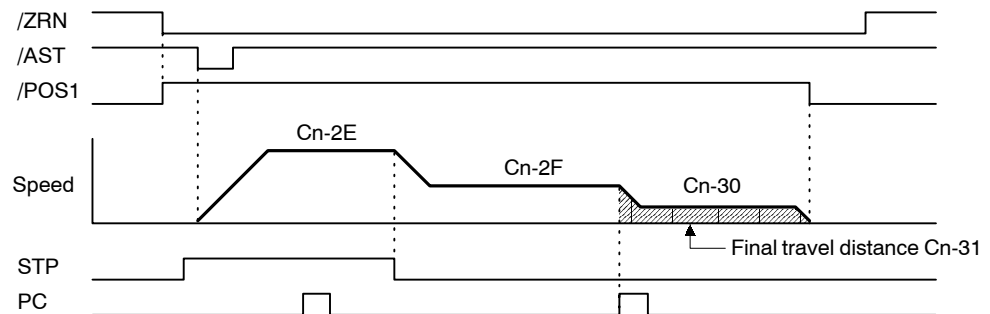

When the STP signal is closed (at low level) at the start of the machine zero point return operation, the motor will rotate in the opposite direction to the machine zero point return direction (set in bit 4 of Cn-29) at machine zero point return feed speed (set in Cn-2E). When the STP signal is open (at high level), the motor will decelerate to a stop, and restart rotation in the ma-

chine zero point return direction at the machine zero point return feed speed (set in Cn-2E). When the signal changes from open (high level) to closed (low level), the load will decelerate to the machine zero point return approach speed (set in Cn-2F), reach the machine zero point return creep speed (set in Cn-30) at the initial phase-C pulse, move the machine zero point return final travel distance from the point of the phase-C pulse (Cn-31), and stop.

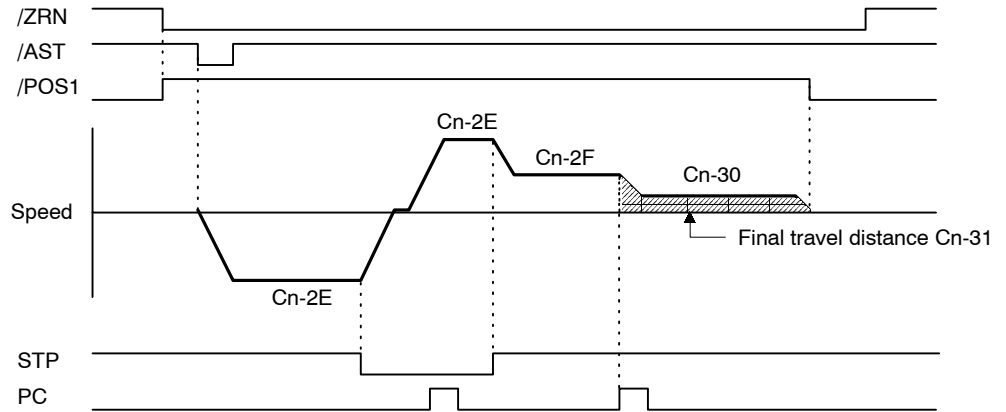

Note: The above diagram shows an example for the following settings:

- Bits B and C of Cn-33 set to 0 (AST signal logic)
- Bit 4 of Cn-29 set to 0 (direction of machine zero point return)
- Parameter Cn-31 \geq 0 (machine zero point return final travel distance)

3.11 Encoder Outputs

Encoder output signals **divided** inside the SERVOPACK can be output externally. These signals can be used to form a position control loop in the host controller.

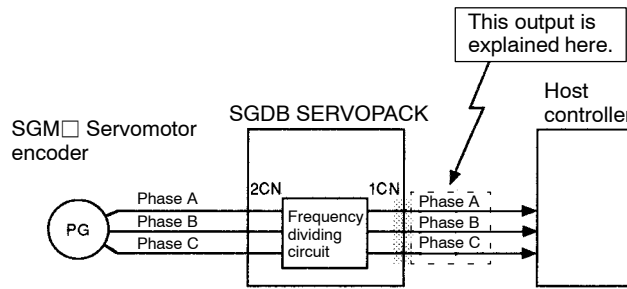

The output circuit is for line driver output. Connect each signal line according to the following circuit diagram.

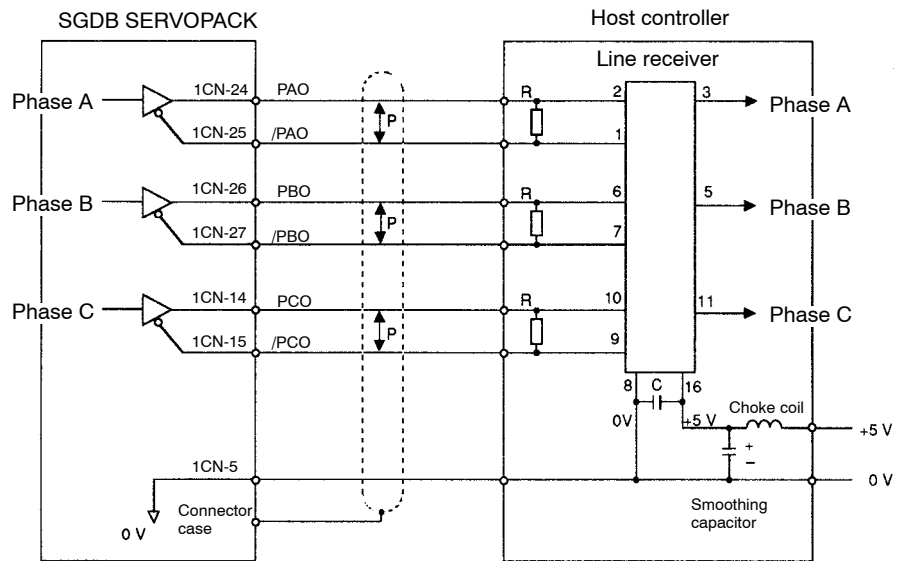

⇄P: Represents twisted-pair cables

Line receiver used: SN75175 manufactured by Texas Instruments Inc. or MC3486 (or equivalent)

R (termination resistor): 220 to 470 Ω

C (decoupling capacitor): 0.1 μF



◆ **Divided (or dividing)**

“Dividing” means converting an input pulse train from the encoder mounted on the motor according to the preset pulse density and outputting the converted pulse. The unit is pulses per revolution.

Output Signals

Output signals are described below.

Output → PAO 1CN-24	Encoder Output Phase-A
Output → /PAO 1CN-25	Encoder Output Phase- \bar{A}
Output → PBO 1CN-26	Encoder Output Phase-B
Output → /PBO 1CN-27	Encoder Output Phase- \bar{B}
Output → PCO 1CN-14	Encoder Output Phase-C
Output → /PCO 1CN-15	Encoder Output Phase- \bar{C}
Output → SG 1CN-5	Signal Ground
Output → FG Connector Case	Frame Ground

SG: Connect to 0 V of the host controller.

FG: Connect to the shielded wire of the cable.

Divided encoder signals are output.

Output Phase Form

- Incremental Encoder

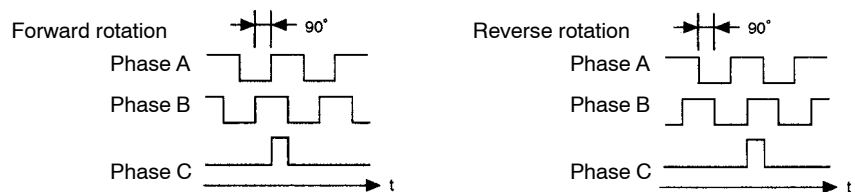

- Absolute Encoder

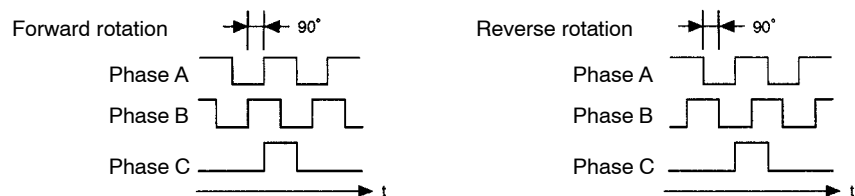

Setting the Pulse Dividing Ratio

Set the pulse dividing ratio in the following parameter.

Cn-0A	PG Dividing Ratio Setting	Unit: P/R	Setting Range: 16 to 32768	Factory Setting: 8192
--------------	------------------------------	--------------	-------------------------------	--------------------------

Sets the number of output pulses for PG output signals (PAO, /PAO, PBO and /PBO).

Pulses from motor encoder (PG) are divided by the preset number of pulses before being output.

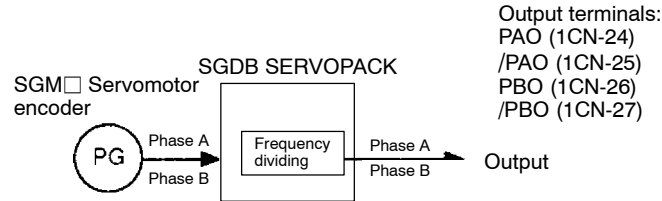

The number of output pulses per revolution is set in this parameter. Set this value according to the command unit of the machine or controller to be used.

The setting range varies according to the encoder used.

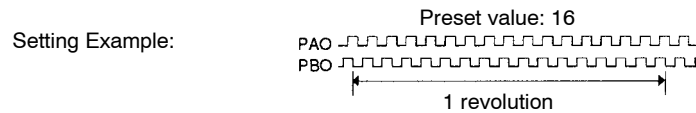

Motor Encoder Specifications	Number of Encoder Pulses per Revolution	Setting Range
2	Incremental encoder: 8192 pulses per revolution	16 to 8192
3	Incremental encoder: 2048 pulses per revolution	16 to 2048
6	Incremental encoder: 4096 pulses per revolution	16 to 4096
W	Absolute encoder: 1024 pulses per revolution	16 to 1024
S	Absolute encoder: 8192 pulses per revolution	16 to 8192

After changing the parameter setting, always turn the power OFF, then ON.

The pulse dividing ratio does not affect the gear ratio settings (set in Cn-23 to Cn-25) for the electronic gear function.

3

3.12 External Pulse Generators

In the SERVOPACK, full closed loops can be formed using external pulse generators.

Set the following memory switch bit to use an external pulse generator.

Cn-33 Bit E	External Pulse Generator	Factory Setting: 0
--------------------	--------------------------	--------------------

Setting	Meaning
0	Does not use an external pulse generator.
1	Uses an external pulse generator.

External pulse generator signal inputs are outlined below.

→ Input PULS 1CN-3	External Pulse Generator Phase A Input
→ Input /PULS 1CN-4	External Pulse Generator Phase \bar{A} Input
→ Input SIGN 1CN-6	External Pulse Generator Phase B Input
→ Input /SIGN 1CN-7	External Pulse Generator Phase \bar{B} Input
→ Input CC 1CN-10	External Pulse Generator Phase C Input
→ Input /CC 1CN-9	External Pulse Generator Phase \bar{C} Input

- Refer to 3.9 *Pulse Operation Mode* for information on pulse types and wiring for external pulse generators.
- There is one-to-one correspondence between line PG pulses and command units. As a result, one line PG pulse is read as a move equivalent to one command unit. Electronic gears, therefore, must be set so that one command unit corresponds to one line PG pulse. Refer to 3.1.5 *Electronic Gear*.
- Phase C inputs need not be connected if machine zero point return in mode I or III or external positioning is not used, and external pulse generators are used.

Use the following contact input to switch between external and motor pulse generators, when external pulse generators are used.

→ Input /LPG 6CN-21	Line Pulse Generator Selection
----------------------------	--------------------------------

6CN-21 is at low level when ON.	Switches position feedback to the external pulse generator.
6CN-21 is at high level when OFF.	Switches position feedback to the motor pulse generator.

Cn-32 Bit 7	Feedback after Positioning Completed	Factory Setting: 0
--------------------	--------------------------------------	--------------------

Setting	Meaning
0	Motor PG
1	/LPG contact

Set this memory switch bit to 0 to force positioning feedback to the motor pulse generator after positioning is complete.

3

3.13 External Position Indicator

The wiring for connecting the MCIF-L8 External Position Indicator to the SERVOPACK is shown in the following diagram.

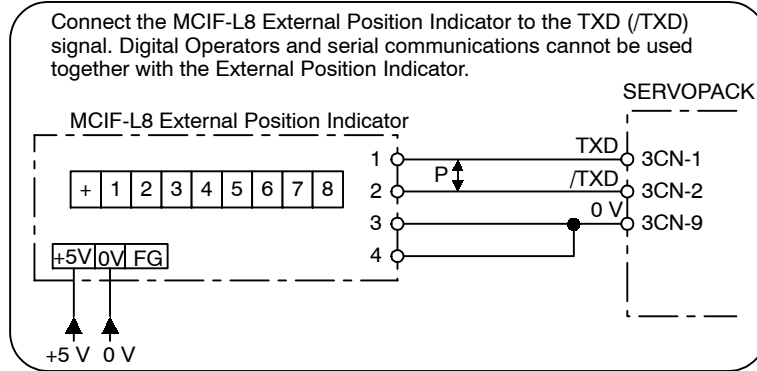

Set the following memory switch bit to use an External Position Indicator.

Cn-33 Bit 9	External Position Indicator	Factory Setting: 0
--------------------	-----------------------------	--------------------

Setting	Meaning
0	Does not use an External Position Indicator.
1	Uses an External Position Indicator.

Note: The output terminal on the SERVOPACK for the External Position Indicator is the same as the transmission output terminal for serial communications. External position indicators, therefore, cannot be used at the same time as serial communications or Digital Operators.

Set the Cn-33 memory switch to send only External Position Indicator data through the SERVOPACK serial output. Any data can be sent to the SERVOPACK if serial communications is used with bit 9 of Cn-33 still set to 1 (“Use an External Position Indicator”). If data is received, the SERVOPACK serial output will return to normal mode, and normal data can be received and sent. To use a Digital Operator, connect it to the SERVOPACK and turn ON the SERVOPACK control power supply.

To use the External Position Indicator again, turn ON the SERVOPACK control power again.

Set the following parameter to change the position of the decimal point for the External Position Indicator.

Cn-3F	Shifting the Position of Decimal Point and the Digits of Digital Switch	Setting Range: 0 to 7	Factory Setting: 0
--------------	---	-----------------------	--------------------

The decimal point indicating the value set in Cn-3F will flash.

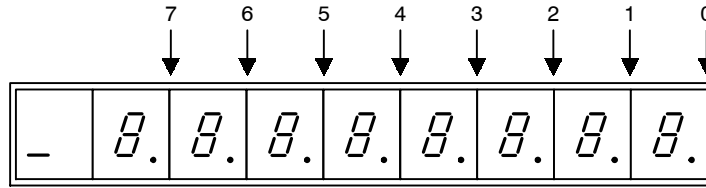

External Position Indicator

This parameter is also used for shifting the digits in the digital switches. Therefore, the digits in the digital switches and the position of the decimal point on the External Position Indicator cannot be shifted independently.

When using digital switches, Cn-3F is used to shift the value of each position command and input feed speed leftwards.

3

Example: If Cn-3F is set to 3, the digital switch position command is set to 123, and the feed speed is set to 456, the position command and feed speed values will be as follows:

$$\text{Position command} = 123 \times 10^3 = 123000 \text{ command units}$$

$$\text{Feed speed} = 456 \times 10^3 = 456000 \times 1000 \text{ command units/min}$$

3.14 Setting the Stop Function

3.14.1 Dynamic Brake

To stop the servomotor by applying **dynamic brake (DB)**, set desired values in the following memory switch bits. If dynamic brake is not used, the servomotor will stop naturally due to machine friction.

Cn-01 Bit 6	How to Stop Motor When Servo is Turned OFF	Factory Setting: 0
Cn-01 Bit 7	Operation to Be Performed When Motor Stops After Servo is Turned OFF	1.5 kW or less: 1 2.0 kW or more: 0

The SERVOPACK enters servo OFF status when:

- Servo ON input signal (/S-ON, 1CN-28) is turned OFF
- Serial command SVOFF is received
- Servo alarm occurs
- Power is turned OFF

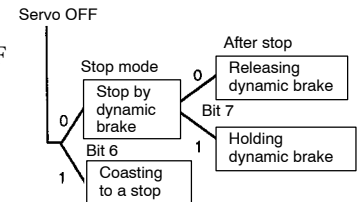

Specify how to stop the motor when one of the above events occurs during operation.

	Setting	Meaning
Cn-01 bit 6	0	Stops the motor by dynamic brake.
	1	Causes the motor to coast to a stop. The motor power is OFF and stops due to machine friction.

If dynamic brake stop mode is selected, specify the operation to be performed when the motor stops.

	Setting	Meaning
Cn-01 bit 7	0	Releases dynamic brake after the motor stops.
	1	Does not release dynamic brake even after the motor stops.

For 2.0 kW models, bit 7 of Cn-01 can be set to 0 only.



◆ **Dynamic brake (DB)**

One of the general methods to cause a motor sudden stop. “Dynamic brake” suddenly stops a servomotor by shorting its electrical circuit. This dynamic brake circuit is incorporated in the SERVOPACK.

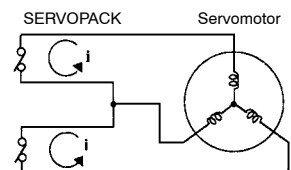

3.14.2 Holding Brake

Holding brake is useful when a servo drive is used to control a vertical axis. A servomotor with brake prevents the movable part from shifting due to gravitation when the system power is turned OFF.

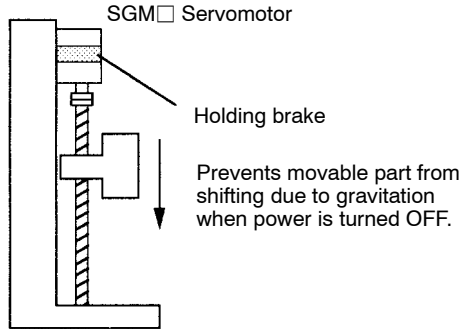

3

IMPORTANT

The built-in brake in an SGM Servomotor with a brake uses de-energization operation, which is used for holding purposes only and cannot be used for braking purposes. Use the holding brake only to retain a stopped motor.

Wiring Example

Use SERVOPACK contact-output-signal /BK and brake power supply to form a brake ON/OFF circuit. An example of standard wiring is shown below.

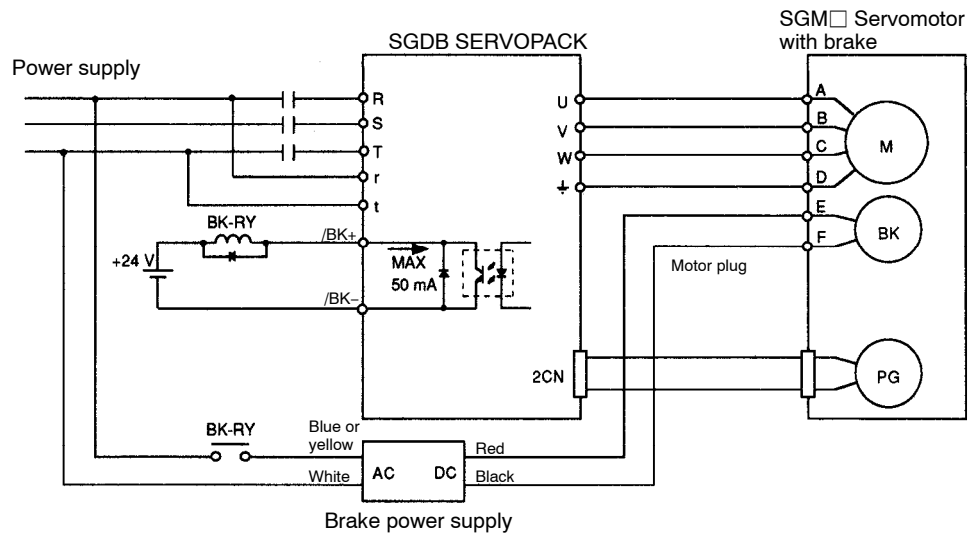

BK-RY: Brake control relay

Brake power supply has two types (200 V, 100 V).

Output → /BK Brake Interlock Output

This output signal controls the brake when a motor with brake is used. This signal terminal need not be connected when a motor without brake is used.

ON Status: Circuit is closed or signal is at low level.	Releases the brake.
OFF Status: Circuit is open or signal is at high level.	Applies the brake.

Related Parameters

Cn-12	Delay time from brake signal until servo OFF
Cn-15	Speed level for brake signal output during motor rotation
Cn-16	Output timing of brake signal during motor rotation

Set the following parameter to specify the 1CN pin to which the /BK signal is output.

Cn-2D	Output Signal Selection	Setting Range: 111 to 666	Factory Setting: 214
--------------	-------------------------	------------------------------	-------------------------

This parameter is used to select a function signal as the 1CN output signal.

1's digit	Select the 1CN-16 and 1CN-17 (/BK) functions.
10's digit	Select the 1CN-18 and 1CN-19 (/TGON) functions.
100's digit	Select the 1CN-20 and 1CN-21 (/S-RDY) functions.

Set Value	Function
1	/TGON
2	/S-RDY
3	/CLT
4	/BK
5	Overload warning
6	Overload alarm

Example: /BK is output to 1CN-16 and 1CN-17.

Cn-2D=□□4

■ Brake ON Timing

If the machine moves slightly due to gravity when the brake is applied, set the following parameter to adjust brake ON timing:

Cn-12	Delay time from the Brake Command until Servo OFF	Unit: 10 ms	Setting Range: 0 to 50	Factory Setting: 0
--------------	---	----------------	---------------------------	-----------------------

This parameter is used to set output timing of brake control signal /BK and servo OFF operation (motor output stop) when SGM□ Servomotor with brake is used.

Brake Timing when Motor is in Stopped Status

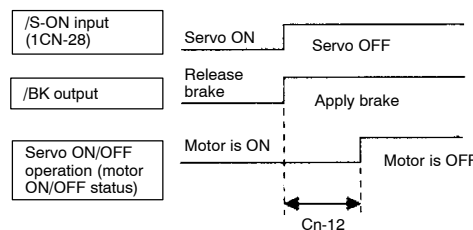

With the standard setting, the servo is turned OFF when /BK signal (brake operation) is output. The machine may move slightly due to gravitation. This movement depends on machine configuration and brake characteristics. If this happens, use this parameter to delay servo OFF timing to prevent the machine from moving.

This parameter is used to set the brake ON timing when the motor is stopped.

For brake ON timing during motor operation, use Cn-15 and Cn-16.

■ /BK Signal Output Conditions during Motor Operation

Set the following parameters to adjust brake ON timing so that holding brake is applied when the motor stops.

Cn-15	Speed Level at which Brake Signal is Output during Motor Rotation	Unit: min ⁻¹	Setting Range: 0 to 500	Factory Setting: 100
Cn-16	Output Timing of Brake Signal during Motor Rotation	Unit: 10 ms	Setting Range: 10 to 100	Factory setting: 50

Cn-15 and Cn-16 are used for SGM□ Servomotors with brake. Use these parameters to set brake timing used when the servo is turned OFF by input signal /S-ON (1CN-28) or alarm occurrence during motor rotation.

Brakes for SGM□ Servomotors are designed as holding brakes. Therefore, brake ON timing when the motor stops must be appropriate. Adjust the parameter settings while observing machine operation.

Brake Timing when Motor is in Stopped Status

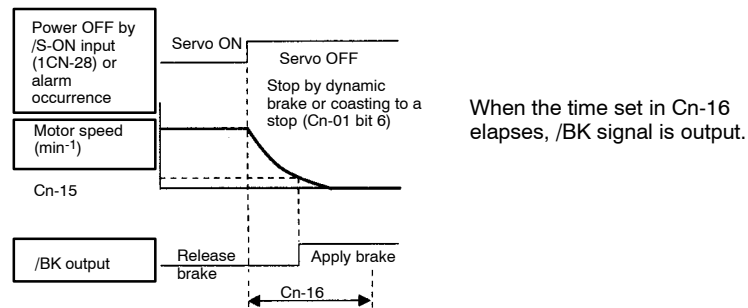

Conditions for /BK signal output during motor operation. The circuit is opened in either of the following situations.

1	Motor speed drops below the value set in Cn-15 after servo is turned OFF.
2	The time set in Cn-16 has elapsed since servo was turned OFF.

If the maximum motor speed or a speed equal to or greater than the Cn-03 setting (speed limit) is set in Cn-15, the lower value of the maximum speed and the speed limit values will be used.

3.15 Smooth Operation

3.15.1 Adjusting Gain

If speed loop gain or position loop gain exceeds the allowable limit for the servo system including the machine to be controlled, the system will vibrate or become too susceptible. Under such conditions, smooth operation cannot be expected. Reduce each loop gain value to an appropriate value.

Check and reset the loop gain when:

- Automatically set loop gain values need to be checked after autotuning. (Refer to 3.16.1 *Autotuning Function*.)
- Each loop gain value checked above is to be directly set for another SERVOPACK.
- Response performance needs to be further enhanced after autotuning, or servo gain values need to be reset for a system with lower response performance.

■ Setting Position Loop

Set the following parameters related to position loop as necessary.

Cn-1A	Position Loop Gain (Kp)	Unit: 1/s	Setting Range: 1 to 1000	Factory Setting: 40
--------------	-------------------------	-----------	--------------------------	---------------------

This parameter is a position loop gain for the SERVOPACK. Increasing the position loop gain value provides position control with higher response and less error. However, there is a certain limit depending on machine characteristics. This parameter is automatically set by the autotuning function.

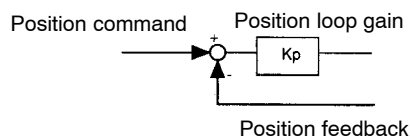

Cn-1E	Overflow	Unit: 256 Command Units	Setting Range: 1 to 32767	Factory Setting: 1024
--------------	----------	-------------------------	---------------------------	-----------------------

Set in this parameter the error pulse level at which a position error pulse overflow alarm (alarm A.D0) is detected. If the machine permits only a small position loop gain value to be set in Cn-1A, an overflow alarm may arise during high-speed operation. In this case, increase the value set in this parameter to suppress alarm detection.

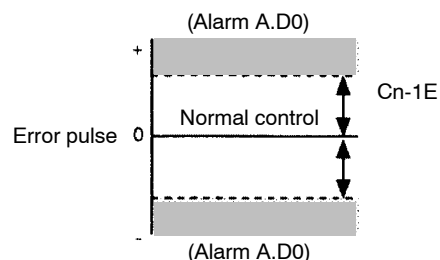

■ Setting Speed Loop

Set the following parameters related to speed loop as necessary.

Cn-04	Speed Loop Gain (Kv)	Unit: Hz	Setting Range: 1 to 4000	Factory Setting: 80
Cn-05	Speed Loop Integration Time Constant (Ti)	Unit: 0.01 ms	Setting Range: 200 to 51200	Factory Setting: 2000

Cn-04 and Cn-05 are speed loop gains and an integration time constant for the SERVOPACK, respectively. The higher the speed loop gain value or the smaller the speed loop integration time constant value, the higher the speed control response. There is, however, a certain limit depending on machine characteristics.

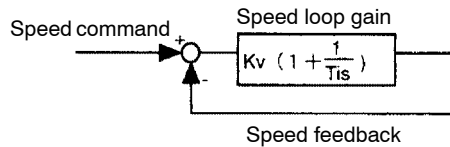

The unit of speed loop gain (Kv) is Hz, but this value is obtained when GD^2_M equals GD^2_L . Therefore, the value must be converted using load $GD^2 (= GD^2_L)$ as follows:

$$Kv \text{ value (Hz)} = \frac{\text{Set value in Cn-04} \times 2}{1 + (GD^2_L/GD^2_M)}$$

These parameters are automatically set by the autotuning function.

3.15.2 Setting the Torque Command Filter Time Constant

If the machine causes vibration, possibly resulting from the servo drive, adjust the following filter time constant. Vibration may stop.

Cn-17	Torque Command Filter Time Constant	Unit: 100 μ s	Setting Range: 0 to 250	Factory Setting: 0
--------------	-------------------------------------	-------------------	-------------------------	--------------------

Cn-17 is a torque command filter time constant for the SGDB SERVOPACK. The smaller the value, the higher the torque control response. There is, however, a certain limit depending on machine conditions.

With the standard setting, the machine may cause vibration resulting from the servo drive. In this case, increase the constant setting. Vibration may stop. Vibration can be caused by incorrect gain adjustment, machine problems and so on.

■ Switching Torque Command Filter

The following memory switch bit can be used to switch between the primary and secondary torque command filters. The filter to be used depends on machine characteristics. If vibration occurs, select the appropriate filter by changing the memory switch setting.

Cn-02 Bit C	Torque Command Filter Selection	Factory Setting: 0
--------------------	---------------------------------	--------------------

Setting	Meaning
0	Primary filter
1	Secondary filter

3.16 Minimizing Positioning Time

This section describes how to minimize positioning time.

3.16.1 Autotuning Function

If speed loop gain and position loop gain for the servo system are not set properly, positioning may become slow. Techniques and experience are required to set these servo gain values according to machine configuration and machine rigidity.

Σ -series SERVOPACKs have an autotuning function that automatically measures machine characteristics and sets the necessary servo gain values set in the parameters. With this function, even first-time servo users can easily perform tuning.

The following parameters can be automatically set by the autotuning function.

Parameter	Meaning
Cn-04	Speed loop gain
Cn-05	Speed loop integration time constant
Cn-1A	Position loop gain

For details of how to perform autotuning, refer to 5.2.3 *Autotuning*.

3.16.2 Servo Gain Switching

This function switches between position loop gain and speed loop gain depending on the size of the position error. Set the following parameters to use this switching function.

Cn-32 Bit D	Variable Position Loop Gain	Factory Setting: 0
--------------------	-----------------------------	--------------------

Setting	Meaning
0	Does not use variable position loop gain (Cn-34 and Cn-35 are invalid).
1	Uses variable position loop gain (Cn-34 and Cn-35 are valid).

Cn-34	Position Loop Gain 2 (Kp2)	Unit: 1/s	Setting Range: 1 to 1000	Factory Setting: 40
Cn-35	Position Loop Gain Switching Point	Unit: Command Unit	Setting Range: 1 to 10000	Factory Setting: 0

Absolute Value of Position Error	Effective Position Loop Gain
< Cn-35	Cn-1A
\geq Cn-35	Cn-34

Note: Cn-1A is selected unconditionally when Cn-35 is set to 0.

Cn-32 Bit E	Variable Speed Loop Gain	Factory Setting: 0
--------------------	--------------------------	--------------------

Setting	Meaning
0	Does not use variable speed loop gain (Cn-36 and Cn-37 are invalid).
1	Uses variable speed loop gain (Cn-36 and Cn-37 are valid).

Cn-36	Speed Loop Gain 2 (Kv2)	Unit: Hz	Setting Range: 1 to 4000	Factory Setting: 80
Cn-37	Speed Loop Gain Switching Point	Unit: Command Unit	Setting Range: 1 to 10000	Factory Setting: 0

Absolute Value of Position Error	Effective Position Loop Gain
$< \text{Cn-37}$	Cn-04
$\geq \text{Cn-37}$	Cn-36

Note: Cn-04 is selected unconditionally when Cn-37 is set to 0.

3

3.16.3 Feed-forward Control

Feed-forward control shortens positioning time. To use **feed-forward control**, set the following parameter.

Cn-1D	Feed-Forward Gain	Unit: %	Setting Range: 0 to 100	Factory Setting: 0
--------------	-------------------	---------	-------------------------	--------------------

This parameter is set to apply feed-forward frequency compensation to position control inside the SERVOPACK. Use this parameter to shorten positioning time. Too high a value may cause the machine to vibrate. For ordinary machines, set 80% or less in this constant.

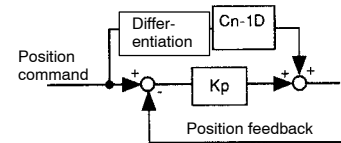

3.16.4 Speed Bias

The settling time for positioning can be reduced by assigning bias to the speed command output part in the SERVOPACK. To assign bias, use the following parameter.

Cn-1C	Bias	Unit: min^{-1}	Setting Range: 0 to 450	Factory Setting: 0
--------------	------	-------------------------	-------------------------	--------------------



◆ Feed-forward control

Control for making necessary corrections beforehand to prevent the control system from receiving the effects of disturbance. Using feed-forward control increases effective servo gain, enhancing response performance.

This parameter is set to assign an offset to a speed command in the SGDB SERVOPACK.

Use this parameter to reduce the settling time.

Set this parameter according to machine conditions.

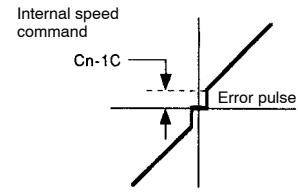

3.16.5 Proportional Control

Input signal /P-CON and serial commands PCON and PCOFF to switch the P/PI control of the speed loop. Refer to 3.6.1 Serial Commands for information on serial commands.

Input → /P-CON 1CN-29	Proportional Control
------------------------------	----------------------

1CN-29 is at low level when ON.	Sets speed loop to P (proportional) control.
1CN-29 is at high level when OFF.	Sets speed loop to P/I (proportional/integral) control.

3

3.16.6 Mode Switch

Use the mode switch for the following purposes:

- To prevent overshoot during acceleration or deceleration (for speed control).
- To prevent undershoot during positioning in order to reduce settling time (for position control).

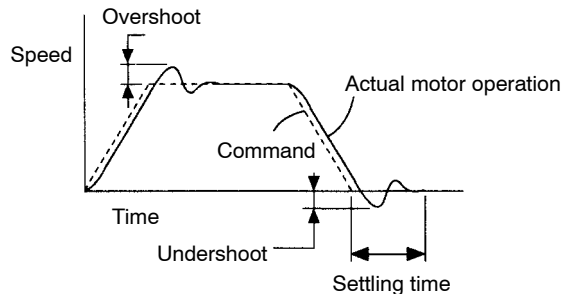

In other words, the mode switch is a function that automatically switches the speed control mode inside the SERVOPACK **from PI control to P control** while certain conditions are being established.

IMPORTANT

1. The mode switch is used to fully utilize performance of a servo drive to achieve very high-speed positioning. The speed response waveform must be observed to adjust the mode switch.
2. For normal use, the speed loop gain and position loop gain set by autotuning provide sufficient speed/position control. Even if overshoot or undershoot occurs, they can be suppressed by setting the acceleration/deceleration type and acceleration/deceleration time.



◆ From PI control to P control

PI control means proportional/integral control and P control means proportional control. In short, switching “from PI control to P control” reduces effective servo gain, making the servo system more stable.

■ Selecting Mode Switches

SERVOPACKs can use the four types of mode switches outlined below. Set the following memory switch bit to select the type of mode switch. The operation level of the mode switch is set in the parameter shown below.

Cn-01 Bit B	Mode Switch Valid/Invalid	Factory Setting: 0
Cn-01 Bit C	Mode Switch Selection	Factory Setting: 0
Cn-01 Bit D	Mode Switch Selection	Factory Setting: 0

Cn-0C	Mode switch level	Conditions	Setting Range	Unit	Factory Setting
		Torque command	0 to 800	%	200
		Speed command	0 to 10000	min ⁻¹	
		Acceleration	0 to 3000	10 (min ⁻¹)/s	
		Error pulse	0 to 10000	Command unit	

Memory Switch Cn-01			Mode Switch Setting	Parameter	Unit
Bit D	Bit C	Bit B			
-	-	1	Does not use mode switch.	-	-
0	0	0	Uses torque command as a detection point. (Standard setting)	Cn-0C	Percentage of rated torque: %
0	1	0	Uses speed command as a detection point.		Motor speed: min ⁻¹
1	0	0	Uses acceleration as a detection point.		Motor acceleration: 10 (min ⁻¹)/s
1	1	0	Uses error pulse as a detection point.		Command unit

When Torque Parameter Is Used as a Detection Point of Mode Switch (Standard Setting)

If a torque command exceeds the torque value set in parameter Cn-0C, the speed loop switches to P control.

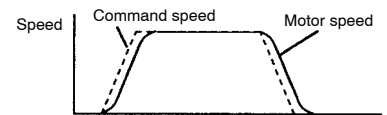

The SGDB SERVOPACK is factory set to this standard mode (Cn-0C = 200).

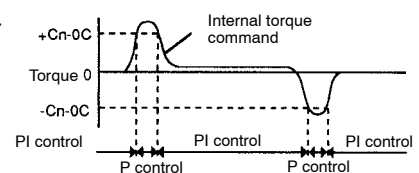

● Example of Use

If a mode switch is not used and PI control is always performed, torque may enter a saturation state during acceleration or deceleration, causing the motor speed to have overshoot or undershoot. Using the mode switch suppresses torque saturation and prevents the motor speed from having overshoot and undershoot.

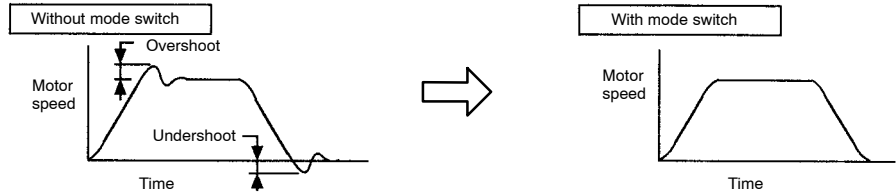

When Speed Command Is Used as a Detection Point of Mode Switch

If a speed command exceeds the value set in parameter Cn-0C, the speed loop switches to P control.

● Example of Use

The mode switch is used to reduce settling time. Generally, speed loop gain must be increased to reduce settling time. Using the mode switch suppresses the occurrence of overshoot and undershoot when speed loop gain is increased.

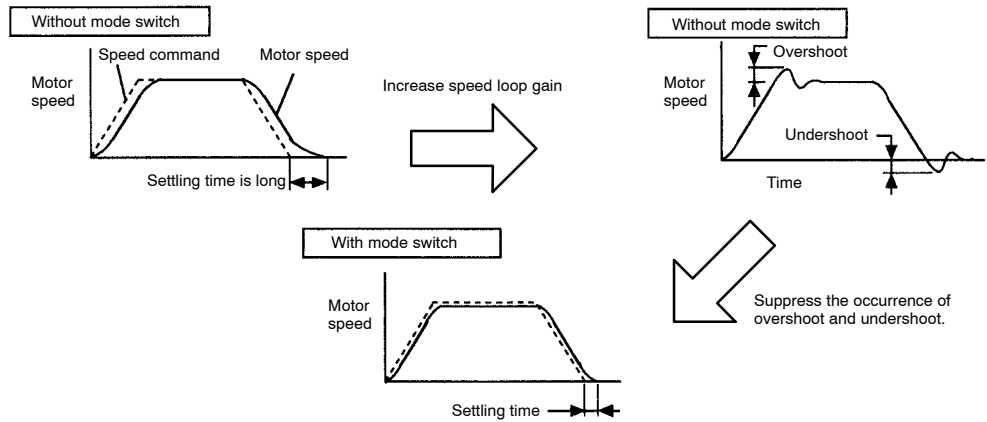
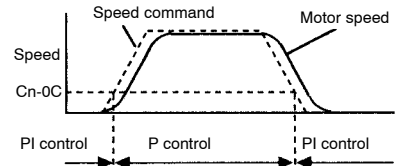

When Acceleration Is Used as a Detection Point of Mode Switch

If motor acceleration exceeds the value set in parameter Cn-0C, the speed loop switches to P control.

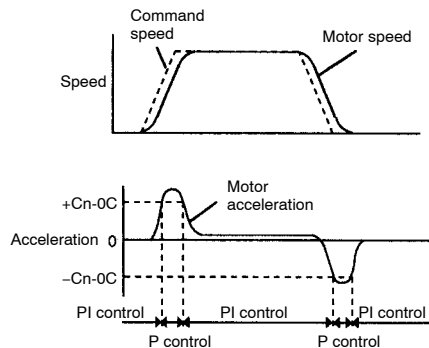

3

- Example of Use

If a mode switch is not used and PI control is always performed, torque may enter a saturation state during acceleration or deceleration, causing the motor speed to have overshoot or undershoot. Using the mode switch suppresses torque saturation and prevents the motor speed from having overshoot and undershoot.

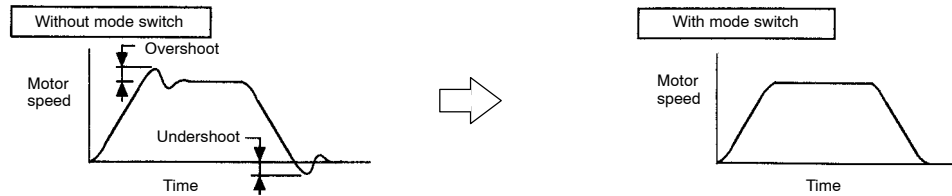

When Error Pulse Is Used as a Detection Point of Mode Switch

This is for position control only.

If an error pulse exceeds the value set in parameter Cn-0C, the speed loop switches to P control.

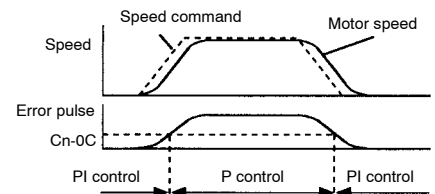

3

- Example of Use

The mode switch is used to reduce settling time.

Generally, speed loop gain must be increased to reduce settling time. Using the mode switch suppresses the occurrence of overshoot and undershoot when speed loop gain is increased.

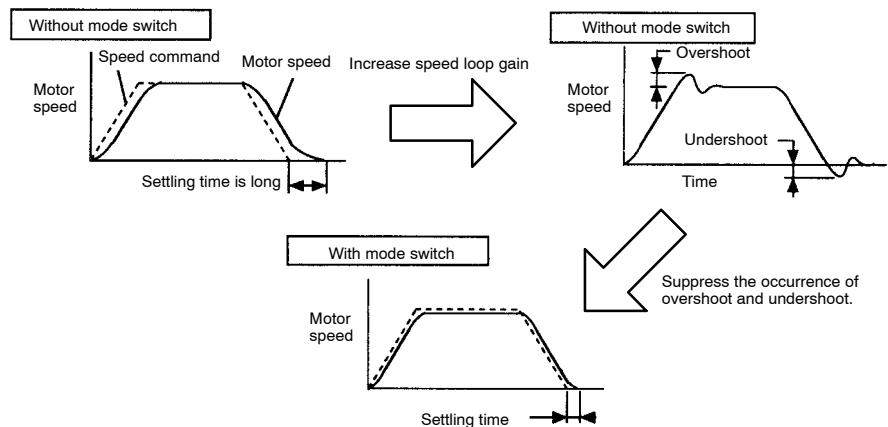

IMPORTANT

If the type of mode switch has been changed (at bits C and D of Cn-01), adjust the mode switch level (Cn-0C) to suit the new type of mode switch.

3.17 Handling Power Loss

Use the following memory switch bit to specify whether or not to output a servo alarm when power is lost.

Cn-01 Bit 5	Operation to be Performed at Recovery from Power Loss	Factory Setting: 0
--------------------	---	--------------------

If the SGDB SERVOPACK detects an instantaneous voltage drop in power supply, it can output servo alarm A.F3 to prevent a hazardous situation.

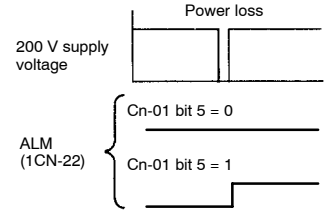

Setting	Meaning
0	Does not output a servo alarm after recovery from power loss.
1	Outputs a servo alarm after recovery from power loss.

Normally, set this memory switch bit to 0. If the /S-RDY signal is not to be used, set the memory switch bit to 1. The /S-RDY signal remains OFF while the main power supply is OFF, regardless of the memory switch setting.

3

3.18 Special Wiring

This section describes special wiring methods including the one for noise control. Always refer to *3.18.1 Wiring Instructions* and *3.18.2 Wiring for Noise Control*, and refer to other sections as necessary.

3.18.1 Wiring Instructions

To ensure safe and stable operation, always refer to the following wiring instructions.

IMPORTANT

1. Always use the following cables for command input and encoder wiring.

	Cable Type	Yaskawa Drawing No.	Maximum Allowable Length
For command input	Twisted-pair cables	JZSP-VBI14 (for 1CN) DE9411288 (for 6CN)	3 m (9.8 ft.)
For encoder	Multi-core shielded twisted-pair cable	B9400064 (for incremental encoder) DP8409123 (for absolute encoder)	20 m (65.6 ft.)

Trim off the excess portion of the cable to minimize the cable length.

2. For grounding, use as thick a cable as possible.
- Ground to 100 Ω or less.
 - Always use one-line grounding.
 - If the motor is insulated from the machine, ground the motor directly.
 - Select grounding phase and grounding point in accordance with the national code and consistent with sound local practices.



3. Do not bend or apply tension to cables.

Since the conductor of a signal cable is very thin (0.2 to 0.3 mm), handle it with adequate care.

4. Use a noise filter to prevent noise interference.
(For details, refer to *3.18.2 Wiring for Noise Control*.)

If the servo is to be used near private houses or may receive noise interference, install a noise filter on the input end of the power supply line. Since this SERVOPACK is designed as an industrial device, it provides no mechanism to prevent noise interference.

Noise filter

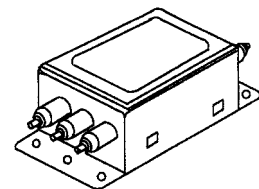

IMPORTANT

5. To prevent malfunction due to noise, take the following actions:

- Place the command input device and noise filter as close to the SERVOPACK as possible.
- Always install a surge absorber circuit in the relay, solenoid and magnetic contactor coils.
- The distance between a power line (such as a power supply line or motor cable) and a signal line must be at least 30 cm (12 in). Do not put the power and signal lines in the same duct or bundle them together.
- Do not share the power supply with an electric welder or electrical discharge machine. When the SERVOPACK is placed near a high-frequency oscillator, install a noise filter on the input end of the power line.

Note: Since SERVOPACK uses high-speed switching elements, signal lines may receive noise. To prevent this, always take the above actions.

2. For details of grounding and noise filters, refer to 3.18.2 Wiring for Noise Control.

6. Use a circuit breaker for wiring (MCCB) or fuse to protect the power supply line from high voltage.

- This SERVOPACK is directly connected to commercial power supply without a transformer. Always use an MCCB or fuse to protect the servo system from accidental high voltage.
- Select an appropriate MCCB or fuse according to the SERVOPACK capacity and the number of SERVOPACKs to be used as shown below.

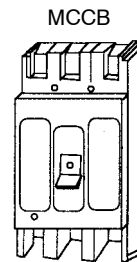

Table 3.2 MCCB or Fuse Capacity for Each Power Capacity

SERVOPACK Model	Power Capacity per SERVOPACK (kVA) *1	Current Capacity per MCCB or Fuse (A) *2
SGDB-02AM	0.65	5
SGDB-05AM	1.1	5
SGDB-10AM	2.0	7
SGDB-15AM	2.5	10
SGDB-20AM	4.0	12
SGDB-30AM	5.0	18
SGDB-50AM	9.5	28
SGDB-60AM	12.5	32
SGDB-75AM	15.0	41
SGDB-1AAM	19.0	60
SGDB-1EAM	30.0	80

* 1. Power capacity at rated load

* 2. Breaking characteristics (25°C): 2 seconds or more for 200%, 0.01 second or more for 700%

Note: A fast-operating fuse cannot be used because the SERVOPACK power supply is a capacitor input type. A fast-operating fuse may blow out when the power is turned ON.

3.18.2 Wiring for Noise Control

■ Example of Wiring for Noise Control

This SERVOPACK uses high-speed switching elements in the main circuit. It may receive “switching noise” from these high-speed switching elements if wiring or grounding around the

SERVOPACK is not appropriate. To prevent this, always wire and ground the SERVOPACK correctly.

This SERVOPACK has a built-in microprocessor (CPU). To protect the microprocessor from external noise, install a noise filter in place.

The following is an example of wiring for noise control.

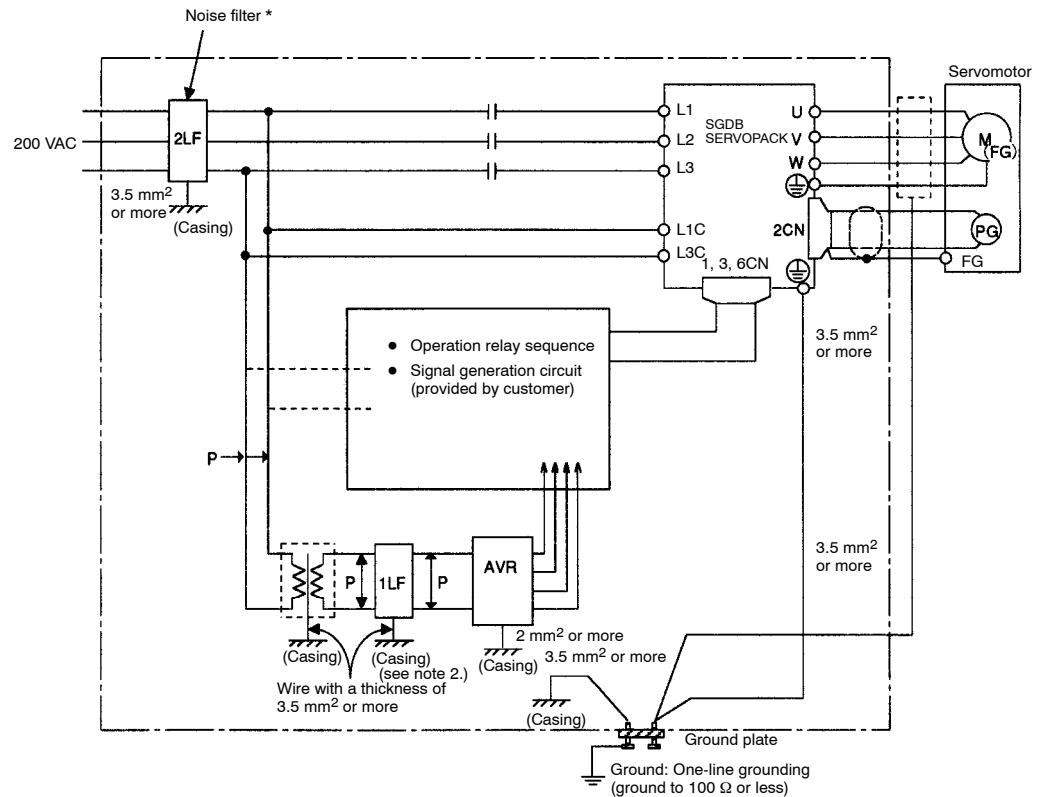

* When using a noise filter, always observe the following wiring instructions:

Note: 1. For a ground wire to be connected to the casing, use a thick wire with a thickness of at least 3.5 mm² (preferably, plain stitch cooper wire).

2. For wires indicated by P↓, use twisted-pair cables whenever possible.

■ Correct Grounding

Always ground the motor frame.

Always connect servomotor frame terminal FG to the SERVOPACK ground terminal (⊕). Be sure to ground the ground terminal (⊕).

If the servomotor is grounded via the machine, a switching noise current will flow from the SERVOPACK power unit through motor stray capacitance. The above grounding is required to prevent the adverse effects of switching noise.

If the command input line receives noise, do the following.

Ground the 0 V line (SG) of the command input line. If the main circuit wiring for the motor is accommodated in a metal conduit, ground the conduit and its junction box. For all grounding, always use one line grounding.

■ Noise Filter Installation

Use an inhibit type noise filter to prevent noise from the power supply line.

Install a noise filter on the power supply line for peripheral equipment as necessary.

The following table lists recommended noise filters for each SERVOPACK model.

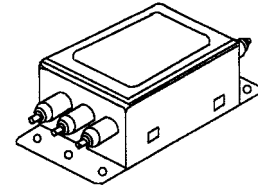
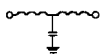



Table 3.3 Noise Filter Models

SERVOPACK Model		Noise Filter Connection	Recommended Noise Filter*		
			Model	Specifications	
0.2 kW	SGDB-02AM	(Correct) 	LF-310	Three-phase 200 VAC, 10 A	
0.5 kW	SGDB-05AM		LF-315	Three-phase 200 VAC, 15 A	
1.0 kW	SGDB-10AM		LF-320	Three-phase 200 VAC, 20 A	
1.5 kW	SGDB-15AM		LF-330	Three-phase 200 VAC, 30 A	
2.0 kW	SGDB-20AM		-	-	
3.0 kW	SGDB-30AM		(Incorrect) 	LF-350	Three-phase 200 VAC, 50 A
5.0 kW	SGDB-50AM			LF-360	Three-phase 200 VAC, 60 A
6.0 kW	SGDB-60AM			LF-380K	Three-phase 200 VAC, 80 A
7.5 kW	SGDB-75AM			FN-258-100 (Manufactured by Shaffner)	Three-phase 200 VAC, 100 A
11.0 kW	SGDB-1AAM				
15.0 kW	SGDB-1EAM				

* These noise filters are manufactured by Tokin Corp. or Shaffner and available from Yaskawa. For noise filters, contact your nearest Yaskawa sales representatives.

Always observe the following installation and wiring instructions. Incorrect use of a noise filter halves its benefits.

3

Separate input lines from output lines.

Do not put the input and output lines in the same duct or bundle them together.

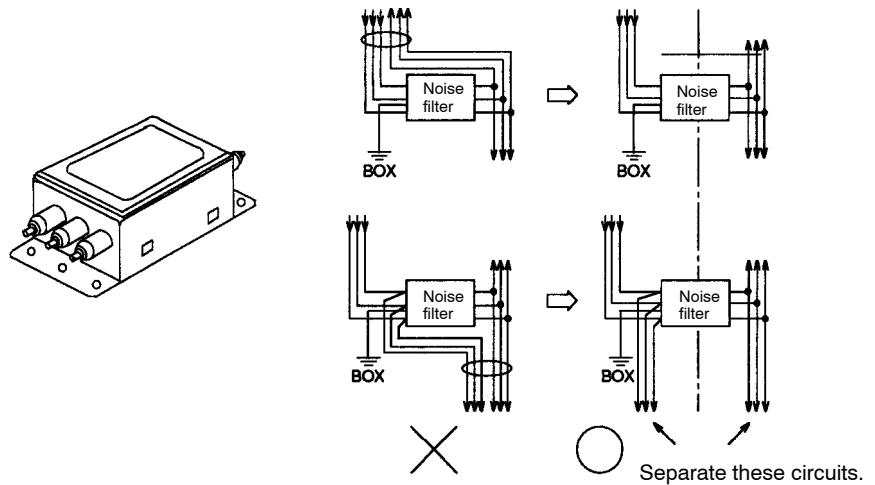

3

Separate the noise filter ground wire from the output lines.

Do not accommodate the noise filter ground wire, output lines and other signal lines in the same duct or bundle them together.

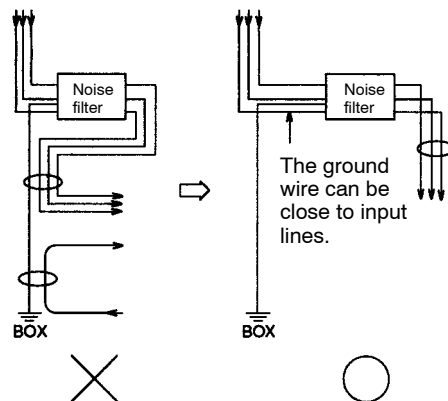

Connect the noise filter ground wire directly to the ground plate.

Do not connect the noise filter ground wire to other ground wires.

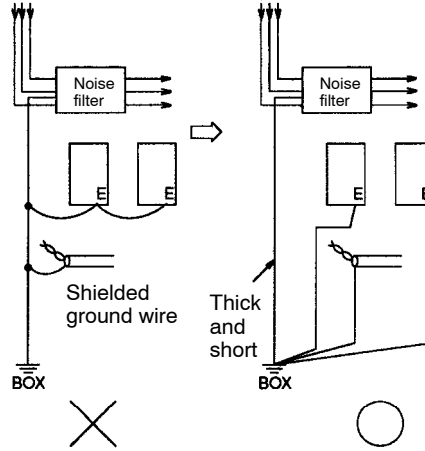

3

When grounding a noise filter inside a Unit.

If a noise filter is located inside a Unit, connect the noise filter ground wire and the ground wires from other devices inside the Unit to the ground plate for the Unit first, then ground these wires.

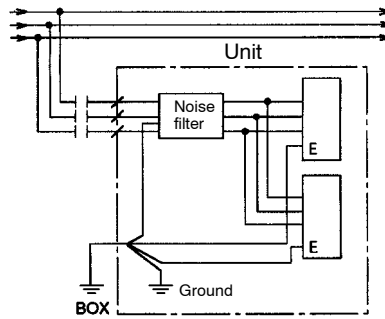

3.18.3 Using More Than One Servodrive

An example of wiring more than one servodrive is shown below.

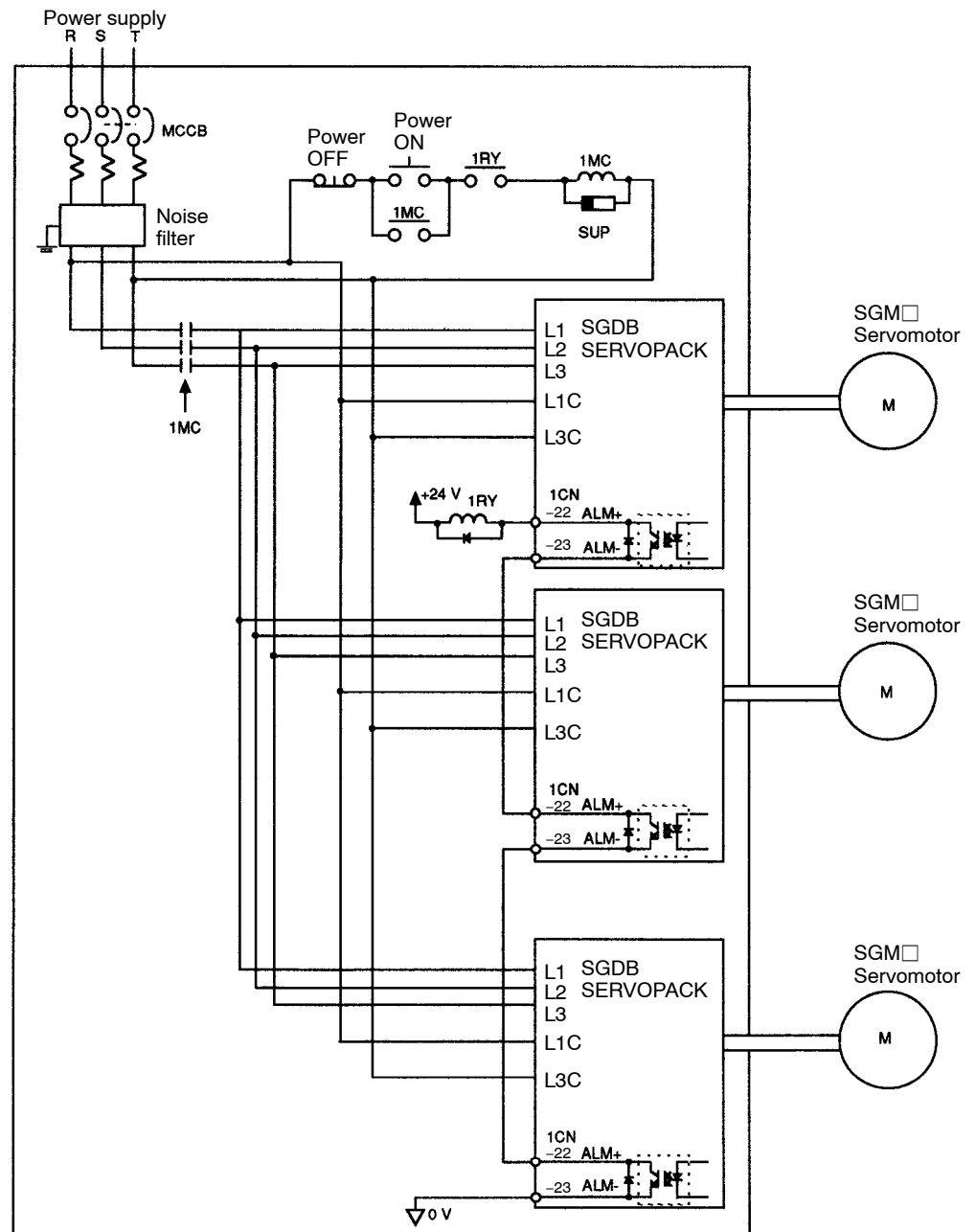

Note: Wire the SERVOPACK so that phase S is the grounding phase.

Connect the alarm output (ALM) terminals for the three SERVOPACKs in series to enable alarm detection relay 1RY to operate.

The output transistor is turned OFF when the ALM output signal invokes alarm state.

3.18.4 Using Regenerative Resistor Units

Multiple servos can share a single MCCB or noise filter. Always select a MCCB or noise filter that has enough capacity for the total power capacity (load conditions) of those servos. For details, refer to page ****.

MCCB

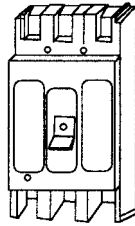

Noise filter

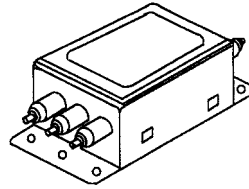

3

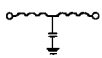
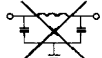
SERVOPACK Model		Noise Filter Connection	Recommended Noise Filter*		
			Model	Specifications	
0.2 kW	SGDB-02AM	(Correct) 	LF-310	Three-phase 200 VAC, 10 A	
0.5 kW	SGDB-05AM		LF-315	Three-phase 200 VAC, 15 A	
1.0 kW	SGDB-10AM		LF-320	Three-phase 200 VAC, 20 A	
1.5 kW	SGDB-15AM		LF-330	Three-phase 200 VAC, 30 A	
2.0 kW	SGDB-20AM		-	-	
3.0 kW	SGDB-30AM		(Incorrect) 	LF-350	Three-phase 200 VAC, 50 A
5.0 kW	SGDB-50AM			LF-360	Three-phase 200 VAC, 60 A
6.0 kW	SGDB-60AM			LF-380K	Three-phase 200 VAC, 80 A
7.5 kW	SGDB-75AM			FN-258-100 (Manufactured by Shaffner)	Three-phase 200 VAC, 100 A
11.0 kW	SGDB-1AAM				
15.0 kW	SGDB-1EAM				

* These noise filters are manufactured by Tokin Corp. or Shaffner and available from Yaskawa. For noise filters, contact your nearest Yaskawa sales representatives.

3.18.4 Using Regenerative Resistor Units

SERVOPACKs of 5.0 kW or higher have no built-in regenerative resistor. For such SERVOPACKs, connect an external regenerative resistor unit.

■ Connecting a Regenerative Resistor Unit

The standard connection diagram for a regenerative resistor unit is shown below.

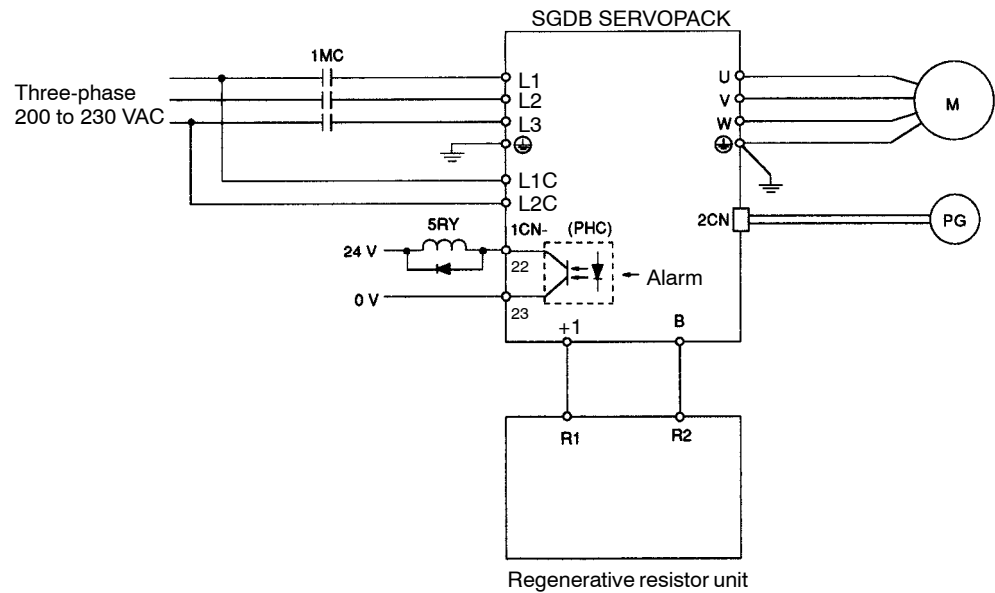

Figure 3.2 Connecting a Regenerative Resistor Unit

■ Regenerative Resistor Units

SERVOPACK Model	Regenerative Resistor Unit Model	Regenerative Resistance (Ω)
SGDB-50AM	JUSP-RA04	6.25
SGDB-60AM		
SGDB-75AM	JUSP-RA05	3.13
SGDB-1AAM		
SGDB-1EAM		

IMPORTANT

A regenerative resistor unit becomes very hot under some regenerative operation conditions of the servo system. Therefore, provide a cooling mechanism for the regenerative resistor, and route the cables so that they are not in contact with the unit.

The resistor specifications of each regenerative resistor unit are as follows:

JUSP-RA04 Model: 25Ω (220 W) \times 4 (connected in parallel)

JUSP-RA05 Model: 25Ω (220 W) \times 8 (connected in parallel)

A regenerative resistor reaches approximately 90°C (at an ambient temperature of 55°C) when it is used at 20% of the rated allowable dissipation value of the resistor. The allowable motor regenerative power (average) is 180 W for the JUSP-RA04, and 350 W for the JUSP-RA05. If the regenerative power (average) exceeds the allowable limit value when the servo system is operating in regenerative operation mode, select an additional regenerative resistor that has a greater rated allowable dissipation value (W). Therefore, always take the servo system operation conditions into consideration when determining which regenerative resistor unit to use.

Example of Allowable Motor Duty Conditions:

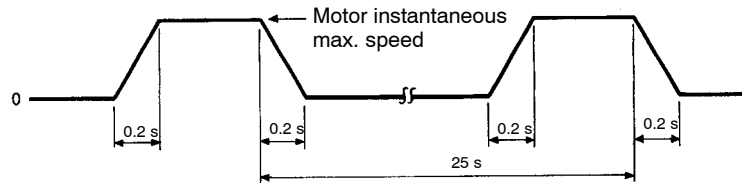

- Motor deceleration torque: Maximum torque
 - Load inertia: Five times the motor rotor inertia
- Assuming that there is no mechanical loss.

3.18.5 Using an Absolute Encoder

An absolute value detection system detects an absolute position of the machine even when the servo system is OFF. If such a system is to be formed in the host controller, use an SGM Servomotor with absolute encoder. Consequently, automatic operation can be performed without machine zero point return operation immediately after the power is turned ON.

- SGM-□□□W 12-bit absolute encoder
- SGM-□□□S 15-bit absolute encoder

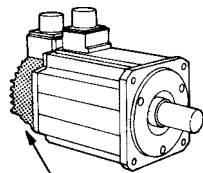

Always detects absolute position



~~Machine zero point return operation~~

■ Selecting Absolute Encoder

Set the following memory switch bit to 1 to select an absolute encoder.

Cn-01 Bit E	Encoder Type Selection	Factory Setting: 0
--------------------	------------------------	--------------------

Sets the encoder type according to the servomotor to be used.

After changing the memory switch setting, turn the power OFF, then ON.

Motor Encoder Specifications	Number of Encoder Pulses Per Revolution	Set Value
2	Incremental encoder: 8192 pulses per revolution	0
3	Incremental encoder: 2048 pulses per revolution	
6	Incremental encoder: 4096 pulses per revolution	
W	Absolute encoder: 1024 pulses per revolution	1
S	Absolute encoder: 8192 pulses per revolution	

Use the following parameter to set the number of pulses for the absolute encoder to be used:

Cn-11	PULSNO Number of Encoder Pulses	Unit: P/R	Setting Range: Number of encoder pulses

Set the number of encoder pulses according to the servomotor to be used.

After changing the memory switch setting, turn the power OFF, then ON.

Motor Encoder Specifications	Number of Encoder Pulses Per Revolution	Set Value
2	Incremental encoder: 8192 pulses per revolution	8192
3	Incremental encoder: 2048 pulses per revolution	2048
6	Incremental encoder: 4096 pulses per revolution	4096
W	Absolute encoder: 1024 pulses per revolution	1024
S	Absolute encoder: 8192 pulses per revolution	8192

IMPORTANT

Incorrect settings of the above parameters may result in abnormal motor operation. To prevent this, always set the parameter correctly.

■ Using a Battery

Use the backup battery to enable the absolute encoder and SERVOPACK to store position and parameter information even when the power is turned OFF. Connect the battery to SERVOPACK terminal 7CN. Refer to 6.6.6 *Back-up Battery*.

■ Setting up Absolute Encoder

Set up the absolute encoder in the following cases:

- When starting the machine for the first time
- When the absolute encoder is not connected to power supply or backup power supply (battery) for more than two days



The setup procedure is as follows:

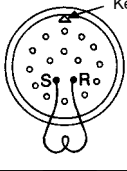

15-bit absolute encoder (Motor encoder specifications=S)

1	Discharging Electricity from the Encoder
<ul style="list-style-type: none"> • Turn the SGDB SERVOPACK OFF, then disconnect the encoder connector. • Short-circuit between encoder connector terminals R and S for at least two minutes. 	
	

2	Turning Power ON
<ul style="list-style-type: none"> • Return the wiring to the normal state. • Connect the battery and turn ON the SGDB SERVOPACK. An A.00 alarm will normally occur here. Set the machine zero point, and then either reset the SERVOPACK or cycle the control power supply. • If an A.00 alarm occurs even after setting the machine zero point, and either resetting the SERVOPACK or cycling the control power supply, then repeat the same procedure from the beginning. • If no problem has occurred, the setup procedure is complete. 	

12-bit absolute encoder (Motor encoder specifications=W)

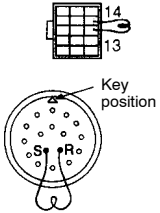
1	Turning SGDB SERVOPACK ON
<ul style="list-style-type: none"> • Wire the SGDB SERVOPACK, motor and encoder in the normal way. • Connect the battery and turn the SGDB SERVOPACK ON. 	
	
2	Turning the Encoder ON
<ul style="list-style-type: none"> • Keep the encoder turned ON for approximately three minutes. • It does not matter even if alarm status arises. 	
	

3	Resetting Data
<ul style="list-style-type: none"> • Turn the SGDB SERVOPACK OFF, then disconnect the encoder connector. • SGM and SGMP Servomotors: Short-circuit between encoder connector terminals 13 and 14 for at least two seconds. • SGMG, SGMD and SGMS Servomotors: Short-circuit between encoder connector terminals R and S for at least two seconds. 	
	
	
4	Turning the Power ON
<ul style="list-style-type: none"> • Return the wiring to the normal state. • Turn ON the SGDB SERVOPACK. An A.00 alarm will normally occur here. Set the machine zero point, and then either reset the SERVOPACK or cycle the control power supply. • If an A.00 alarm occurs even after setting the machine zero point, and either resetting the SERVOPACK or cycling the control power supply, then repeat the same procedure from the beginning. • If no problem has occurred, the setup procedure is complete. 	

IMPORTANT

Setting up the encoder sets the revolution count inside the encoder to 0.

After setting up the encoder, always reset the machine machine zero point. Operating the machine without the machine zero point being reset does not only damage the machine but may also cause an accident resulting in injury or death.

3.18.6 Extending an Encoder Cable

Both incremental and absolute encoders have a standard encoder cable (maximum 20 meters (65.6 ft.)). If a longer cable is required, prepare an extension cable as described below. The maximum allowable cable length is 50 meters (164 ft.).

■ 3-meter (1.98 ft.) Cable with Connectors on Both Ends (for SGM and SGMP)

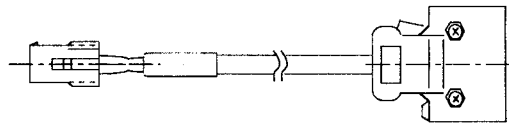

- For incremental encoder: JZSP-CAP00-01
- For absolute encoder: JZSP-CAP10-01

■ 3-meter (1.98 ft.) Cable with Connector on One End

■ Encoder Plug and Cable Clamp (for SGMG, SGMD, and SGMS)

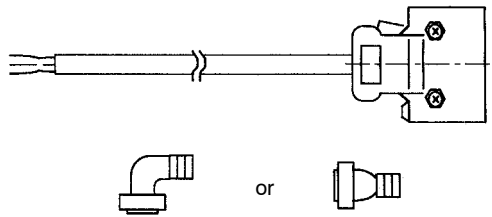

- For incremental encoder: DE9411276-1
- For absolute encoder: DE9411277-1
- L-type plug: MS3108B20-29S

or

- Straight plug: MS3106B20-29S
- Cable clamp: MS3057-12A

■ 50-meter (164 ft.) Extension Cable

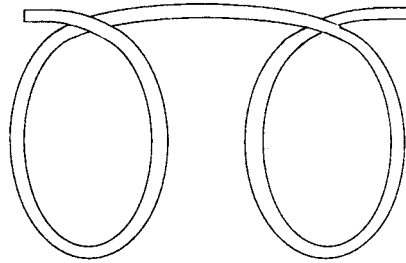

- For both incremental and absolute encoders: DP8409179

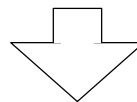

Cut this cable 30 cm (0.98 ft.) or less from each end.

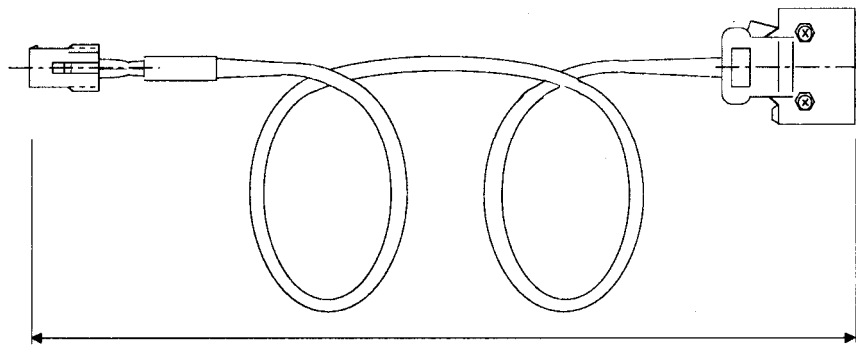
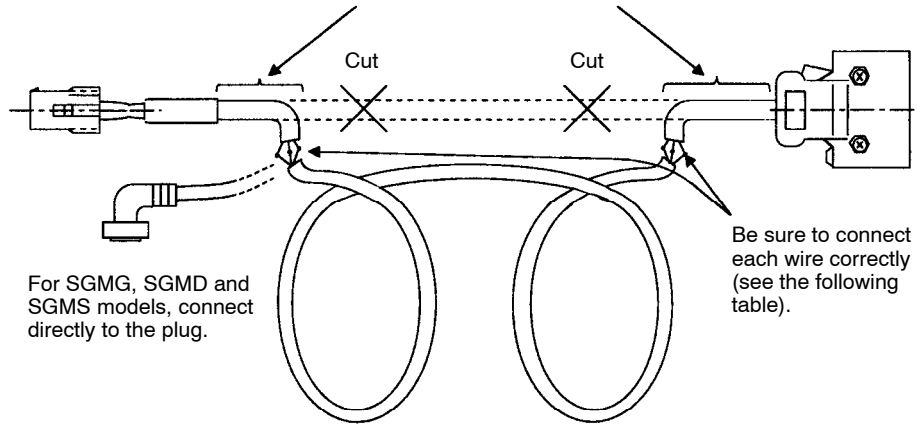

3

Connect cables of the same color to each other as shown in the table below. Wiring for incremental and absolute encoders is different.

Signal Name	Color and Wire Size of Cable with Connectors on Both Ends		Color and Wire Size of 50-meter Extension Cable (DP8409179)	
PG5V	Red	AWG22	Red	AWG16
PG0V	Black	AWG22	Black	AWG16
PA	Blue	AWG26	Blue	AWG26
/PA	White/Blue	AWG26	White/Blue	AWG26
PB	Yellow	AWG26	Yellow	AWG26
/PB	White/Yellow	AWG26	White/Yellow	AWG26
PC	Green	AWG26	Green	AWG26
/PC	White/Green	AWG26	White/Green	AWG26
PS	Purple	AWG26	Purple	AWG26
/PS	White/Green	AWG26	White/Green	AWG26
RESET	White/Gray	AWG26	White/Gray	AWG26
BAT	Orange	AWG26	Orange	AWG26
BAT0	White/Orange	AWG26	White/Orange	AWG26

Only the absolute encoder can be connected.

Note: Make sure to connect the shield wires.

3.18.7 Using SGDB SERVOPACK with High Voltage Lines

SGDB SERVOPACKs use three-phase 200 VAC.

If, however, three-phase 400 VAC class (400 V, 440 V) power supply must be used, prepare the following power transformer (for three-phase).

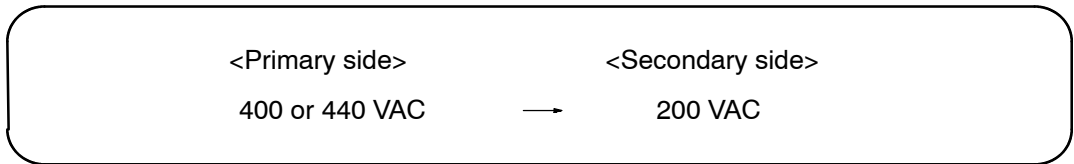

Select appropriate power transformer capacity according to the following table.

3

SERVOPACK Model	Power Supply Capacity per SGDB SERVOPACK (kVA) *
SGDB-02AM	0.65
SGDB-05AM	1.1
SGDB-10AM	2.0
SGDB-15AM	2.5
SGDB-20AM	4.0
SGDB-30AM	5.0
SGDB-50AM	9.5
SGDB-60AM	12.5
SGDB-75AM	15.5
SGDB-1AAM	19.0
SGDB-1EAM	30.0

* At rated load.

When 400-V-class supply voltage is used, power must be turned ON and OFF on the primary side of the power transformer.

3.18.8 Connector Terminal Layouts

This section describes connector terminal layouts for SGDB SERVOPACKs, SGM□ servomotors and Digital Operators.

■ SERVOPACK Connectors

1CN Terminal Layout

			1						19	/TGON-	Motor rotation detection output
2	SG	0 V				20	/S-RDY+	Servo ready output			
4	/PULS	Command and line PG pulse input	3	PULS	Command and line PG pulse input	22	ALM+	Servo alarm output	21	/S-RDY-	Servo ready output
6	SIGN	Command and line PG sign input	5	SG	0 V	24	PAO	PG dividing output phase A	23	ALM-	Servo alarm output
8			7	/SIGN	Command and line PG sign input	26	PBO	PG dividing output phase B	25	/PAO	PG dividing output phase A
10	CC	Line PG machine zero point pulse input	9	/CC	Line PG machine zero point pulse input	28	/S-ON	Servo ON signal	27	/PBO	PG dividing output phase B
12	VTG	Speed monitor	11	TMON	Torque monitor	30	P-OT	Forward overtravel input	29	/P-CON	P control input
14	PCO	PG dividing output phase C	13			32	/STP	Machine zero point return limit switch input	31	N-OT	Reverse overtravel input
16	/CLT+	Output during current limit	15	/PCO	PG dividing output phase C	34	/N-CLT	Reverse current limit ON input	33	/P-CLT	Forward current limit ON input
18	/TGON+	Motor rotation detection output	17	/CLT-	Output during current limit	36			35	+24V	External power supply input

- SERVOPACK end: Connector model: 10236-52A2JL (manufactured by 3M)
- Cable end: Connector model: 10136-3000VE (manufactured by 3M)
Connector case model: 10336-52S0-00S (manufactured by 3M)

2CN Terminal Layout

2	PG0V	PG power supply 0 V	1	PG0V	PG power supply 0 V	12	BAT+	Battery (+) (for absolute encoder only)	11		
			3	PG0V					13	BAT -	Battery (-) (for absolute encoder only)
4	PG5V	PG power supply +5 V	5	PG5V	PG power supply +5 V	14	PC	PG input phase C	15	/PC	PG input phase C
6	PG5V								16	PA	PG input phase A
8	PS	PG input phase S (for absolute en- coder only)	7			18	PB	PG input phase B	17	/PA	PG input phase A
			9	/PS	PG input phase S (for absolute en- coder only)				19	/PB	PG input phase B
10						20					

- SERVOPACK end: Connector model: 10220-52A2JL (manufactured by 3M)
- Cable end: Connector model: 10120-3000VE (manufactured by 3M)
Connector case model: 10320-52S0-00S (manufactured by 3M)

3

6CN Terminal Layout for Station Numbers

2	/AUT-LT	Automatic operation mode display	1	0V1	External power supply input	27	/ERR	Command error output	26	0V2	External power supply input
			3	/MAN- LT	Manual operation mode display				28	/P0	Current station position output
4	/POS1	Positioning complete output (COIN)	5	POS2	Positioning proximity output (NEAR)	29	/P1	Current station position output	30	/P2	Current station position output
6	/AL0	Alarm code output	7	/AL1	Alarm code output	31	/P3	Current station position output	32	/P4	Current station position output
8	/AL2	Alarm code output	9	/AL3	Alarm code output	33	/CD0	Command data input	34	/CD1	Command data input
10			11			35	/CD2	Command data input	36	/CD3	Command data input
12			13	/ZRN	Machine zero point return mode settings input	37	/CD4	Command data input	38	/CD5	Command data input
14	/MAN	Manual operation mode settings input	15	/PULS	Pulse operation mode settings input	39	/CD6	Command data input	40	/CD7	Command data input
16	/MCW	Manual operation (in the cw direction)	17	/MCCW	Manual operation (in the ccw direction)	41	/CD8	Command data input	42	/CD9	Command data input
18	/RST	Reset input	19	/SP2ND	2 nd speed selection input	43	/CD10	Command data input	44	/CD11	Command data input
20	/SP3RD	3 rd speed selection input	21	/LPG	Line PG selection input	45	/DR0	Rotating direction selection input 0	46	/DR1	Rotating direction selection input 1
22	/AST	Start input	23	/ALM RST	Alarm reset input	47	/PS0	Station number read select	48	/PS1	Station number read select
24	STOP	Pause input	25	+24V1	External power supply input	49	+24V2	External power supply input	50		

6CN Terminal Layout for Digital Switches

2	/AUT-LT	Automatic operation mode display	1	0V1	External power supply input	27	/ERR	Command error output	26	0V2	External power supply input
4	/POS1	Positioning complete output (COIN)	3	/MAN-LT	Manual operation mode display	29	/DSO1	Data strobe output	28	/DSO0	Data strobe output
6	/AL0	Alarm code output	5	POS2	Positioning proximity output (NEAR)	31	/DSO3	Data strobe output	30	/DSO2	Data strobe output
8	/AL2	Alarm code output	7	/AL1	Alarm code output	33	/DSI10	Position data input	32	/DSO4	Data strobe output
10			9	/AL3	Alarm code output	35	/DSI12	Position data input	34	/DSI11	Position data input
12			11			37	/DSI14	Position data input	36	/DSI13	Position data input
14	/MAN	Manual operation mode settings input	13	/ZRN	Machine zero point return mode settings input	39	/DSI16	Position data input	38	/DSI15	Position data input
16	/MCW	Manual operation (in the cw direction)	15	/PULS	Pulse operation mode settings input	41	/DSI20	Speed data input	40	/DSI17	Position data input
18	/RST	Reset input	17	/MCCW	Manual operation (in the ccw direction)	43	/DSI22	Speed data input	42	/DSI21	Speed data input
20	/SP3RD	3 rd speed selection input	19	/SP2ND	2 nd speed selection input	45	/DSI24	Speed data input	44	/DSI23	Speed data input
22	/AST	Start input	21	/LPG	Line PG selection input	47	/DSI26	Speed data input	46	/DSI25	Speed data input
24	STOP	Pause input	23	/ALM RST	Alarm reset input	49	+24V2	External power supply input	48	/DSI27	Speed data input
			25	+24V1	External power supply input				50		

6CN Terminal Layout for Serial Communications

2	/AUT-LT	Automatic operation mode display	1	0V1	External power supply input	26	0V2	External power supply input
			3	/MAN-LT	Manual operation mode display	27	/ERR	Command error output
4	/POS1	Positioning complete output (COIN)				29		
			5	POS2	Positioning proximity output (NEAR)			
6	/AL0	Alarm code output				31		
			7	/AL1	Alarm code output			
8	/AL2	Alarm code output				33		
			9	/AL3	Alarm code output			
10						35		
			11					
12						37		
			13	/ZRN	Machine zero point return mode settings input			
14	/MAN	Manual operation mode settings input				39		
			15	/PULS	Pulse operation mode settings input			
16	/MCW	Manual operation (in the cw direction)				41		
			17	/MCCW	Manual operation (in the ccw direction)			
18	/RST	Reset input				43		
			19	/SP2ND	2 nd speed selection input			
20	/SP3RD	3 rd speed selection input				45		
			21	/LPG	Line PG selection input			
22						47		
			23	/ALM RST	Alarm reset input			
24						49		
			25	+24V1	External power supply input			
						50		

6CN Terminal Layout for Command Table

2	/AUT-LT	Automatic operation mode display	1	0V1	External power supply input	27	/ERR	Command error output	26	0V2	External power supply input
4	/POS1	Positioning complete output (COIN)	3	/MAN-LT	Manual operation mode display	29	/P1	Zone signal data output	28	/P0	Zone signal data output
6	/AL0	Alarm code output	5	POS2	Positioning proximity output (NEAR)	31	/P3	Zone signal data output	30	/P2	Zone signal data output
8	/AL2	Alarm code output	7	/AL1	Alarm code output	33	/CD0	Position number data input	32	/P4	Zone signal data output
10			9	/AL3	Alarm code output	35	/CD2	Position number data input	34	/CD1	Position number data input
12			11			37	/CD4	Position number data input	36	/CD3	Position number data input
14	/MAN	Manual operation mode settings input	13	/ZRN	Machine zero point return mode settings input	39	/CD6	Position number data input	38	/CD5	Position number data input
16	/MCW	Manual operation (in the cw direction)	15	/PULS	Pulse operation mode settings input	41	/CD8	Position number data input	40	/CD7	Position number data input
18	/RST	Reset input	17	/MCCW	Manual operation (in the ccw direction)	43			42		
20	/SP3RD	3 rd speed selection input	19	/SP2ND	2 nd speed selection input	45			44		
22	/AST	Start input	21	/LPG	Line PG selection input	47	/PS0	Zone data read selection signal	46		
24	STOP	Pause input	23	/ALM RST	Alarm reset input	49	+24V2	External power supply input	48	/PS1	Zone data read selection signal
			25	+24V1	External power supply input				50		

- SERVOPACK end: Connector model: 10250-6202JL (manufactured by 3M)
- Cable end: Connector model: 10150-3000VE (manufactured by 3M)
Connector case model: 10350-52S0-00S (manufactured by 3M)

Connectors for Absolute Encoders

SGM and SGMP Series

1	Channel A output	Blue
2	Channel \bar{A} output	White/Blue
3	Channel B output	Yellow
4	Channel \bar{B} output	White/Yellow
5	Channel Z output	Green
6	Channel \bar{Z} output	White/Green
7	0 V (power supply)	Black
8	+5 V (power supply)	Red
9	Frame ground (FG)	Green/Yellow
10	Channel S output	Purple
11	Channel \bar{S} output	White/Purple
(12)	(Capacitor reset)	(Gray)
13	Reset	White/Gray
14	0 V (battery)	White/Orange
15	3.6 V (battery)	Orange

Do not use this terminal.
(It is used to discharge
electricity from capacitor
before shipment.)

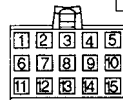

Items to be Prepared by Customer

Cap: 172163-1

Socket: 170361-1 (chain type) or
170365-1 (loose type)

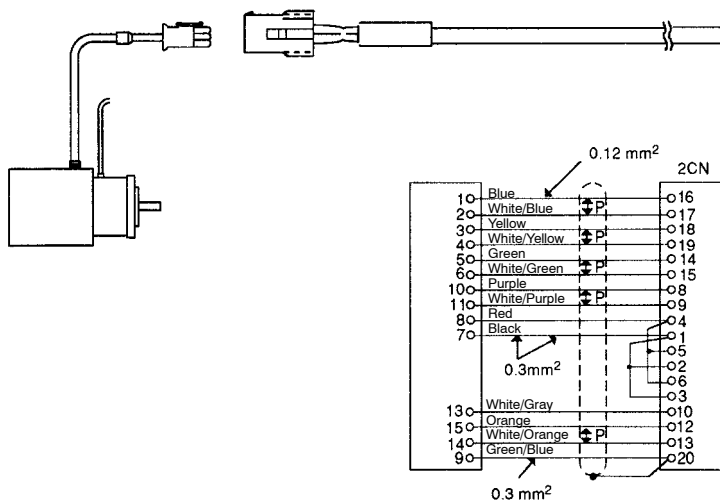
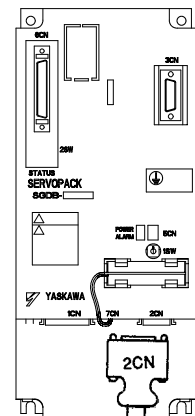

Items to be Prepared by Customer

Case:
10320-52S0-00S
(manufactured by 3M)
Connector:
10120-3000VE
(manufactured by 3M)

■ Connectors for Incremental Encoders

SGMG, SGMD and SGMS Series

A	Channel A output
B	Channel \bar{A} output
C	Channel B output
D	Channel \bar{B} output
E	Channel C output
F	Channel \bar{C} output
G	0 V (power supply)
H	+5 V (power supply)
J	Frame ground (FG)

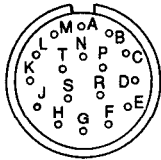

Items to be Prepared by Customer

Plug: (L shaped) MS3108B20-29S or
(Straight) MS3106B20-29S

Cable clamp: MS3057-12A

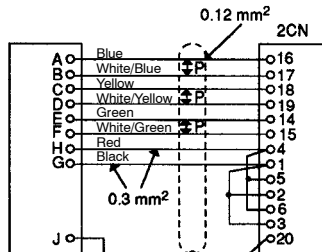
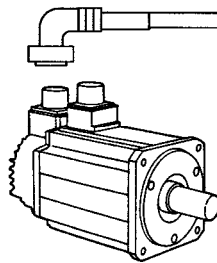
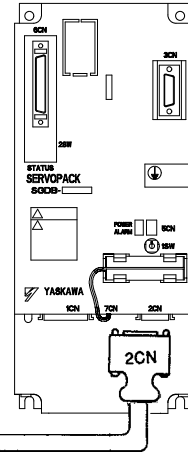

Items to be Prepared by Customer

Case:
10320-52S0-00S
(manufactured by 3M)
Connector:
10120-3000VE
(manufactured by 3M)

3

■ Connectors for Absolute Encoders

SGMG, SGMD and SGMS Series

A	Channel A output
B	Channel \bar{A} output
C	Channel B output
D	Channel \bar{B} output
E	Channel Z output
F	Channel \bar{Z} output
G	0 V (power supply)
H	+5 V (power supply)
J	Frame ground (FG)
K	Channel S output
L	Channel \bar{S} output
R	Reset
S	0 V (battery)
T	3.6 V (battery)

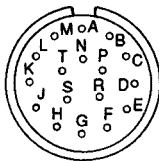

Items to be Prepared by Customer

Plug: (L shaped) MS3108B20-29S or
(Straight) MS3106B20-29S

Cable clamp: MS3057-12A

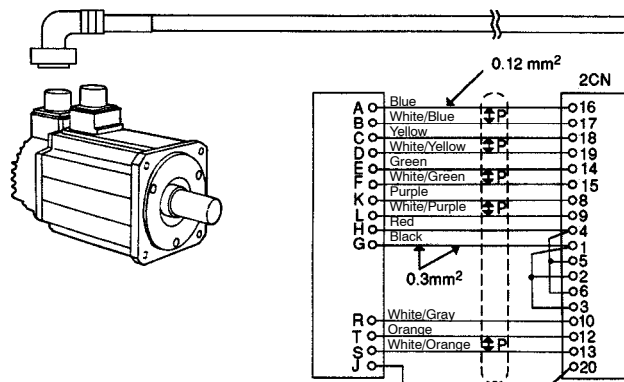
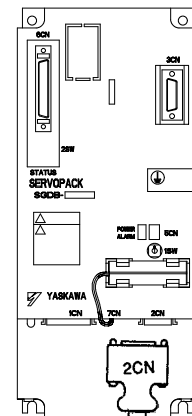

Items to be Prepared by Customer

Case:
10320-52S0-00S
(manufactured by 3M)
Connector:
10120-3000VE
(manufactured by 3M)

■ Connectors and Terminals for Standard Motors (without Brakes)

SGM and SGMP Series

1	Phase U	Red
2	Phase V	White
3	Phase W	Blue
4	Frame ground (FG)	Green

For SGMP-15A

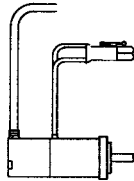
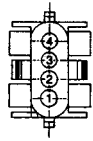

Cap: 172159-1
 Socket: 170362-1 or 170366-1

For SGM-15A
 Cap: 350780-1
 Socket: 350536-6 or 350550-6

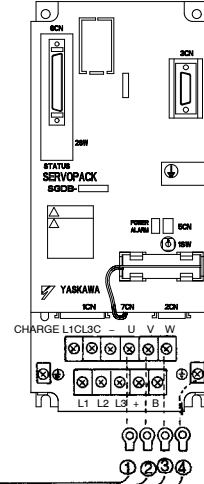

M4 crimp terminal
Items to be Prepared by Customer
 Round crimp terminal R1.25-4TOR
 (manufactured by AMP)

3

■ Connectors and Terminals for Motors with Brakes

SGM and SGMP Series

1	Phase U	Red
2	Phase V	White
3	Phase W	Blue
4	Frame ground (FG)	Green
5	Brake terminal	Black
6	Brake terminal	Black

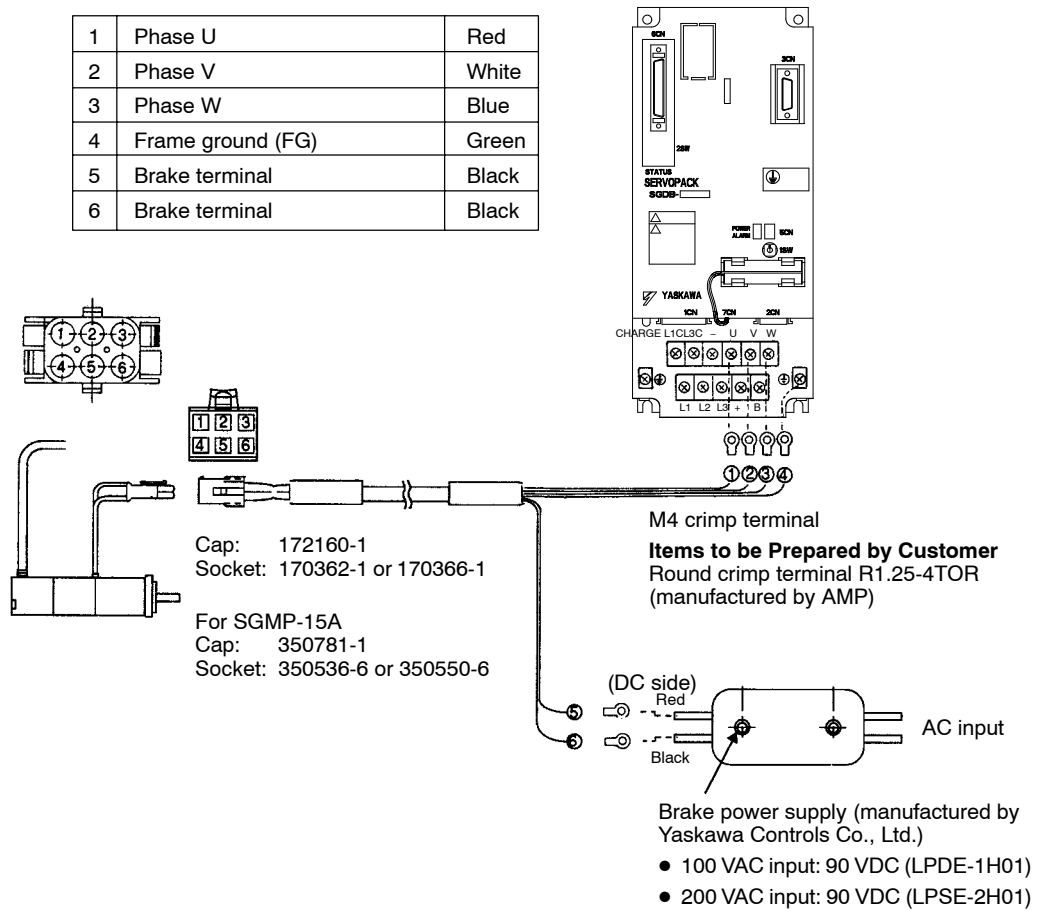

■ Connectors and Terminals for Standard Motors (without Brakes)

SGMG, SGMD and SGMS Series

A	Phase U
B	Phase V
C	Phase W
D	Frame ground (FG)

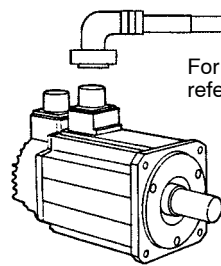
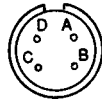
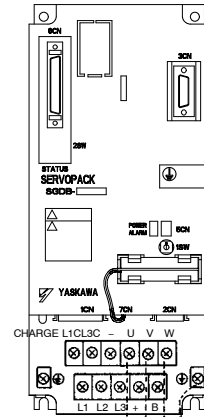

For plug and cable clamp models, refer to 6.6.3 Connector.

3

■ Connectors and Terminals for Motors with Brakes

SGMG, SGMD and SGMS Series

A	Phase U
B	Phase V
C	Phase W
D	Frame ground (FG)
E	Brake terminal
F	Brake terminal

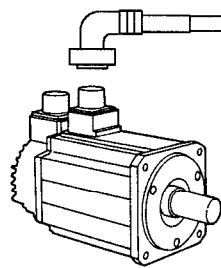
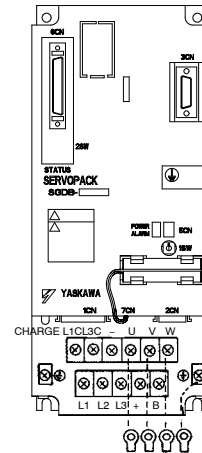
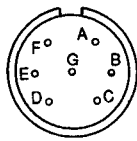

For plug and cable clamp models, refer to 6.6.3 Connector.

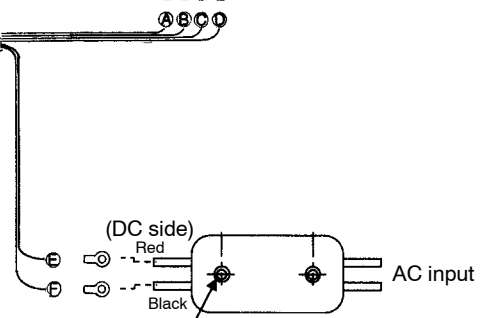

Brake power supply (manufactured by Yaskawa Controls Co., Ltd.)

- 100 VAC input: 90 VDC (LPDE-1H01)
- 200 VAC input: 90 VDC (LPSE-2H01)

■ Connectors for Digital Operators

- JUSP-OP02A-1 (Hand-held)

- JUSP-OP03A (Mounted)

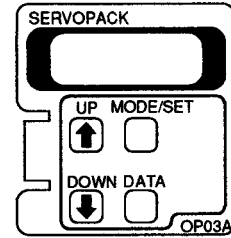
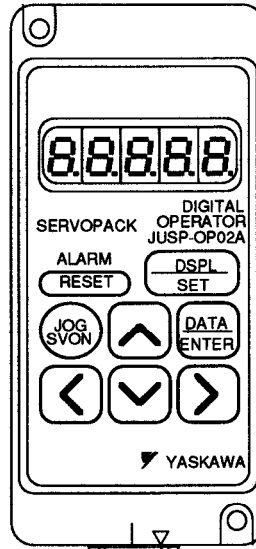

Fits directly into 3CN on the SERVOPACK.

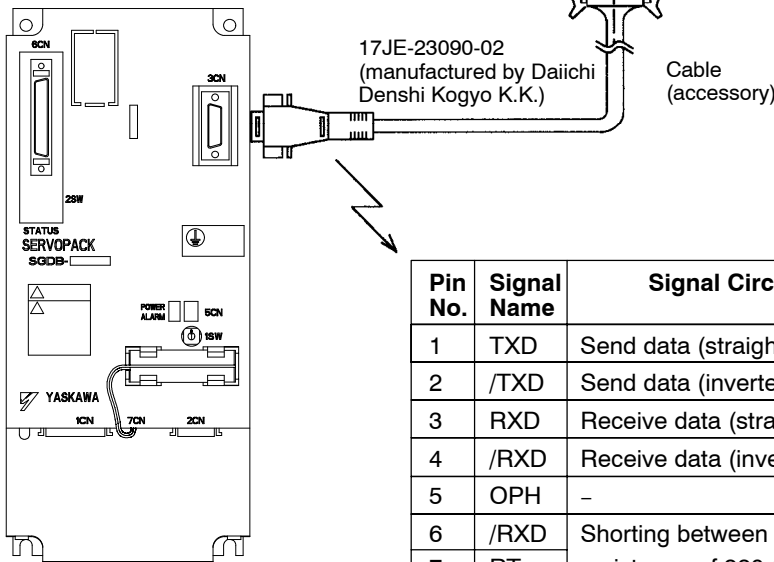

Pin No.	Signal Name	Signal Circuit Name	Signal Direction
1	TXD	Send data (straight signal)	P ← S
2	/TXD	Send data (inverted signal)	P ← S
3	RXD	Receive data (straight signal)	P → S
4	/RXD	Receive data (inverted signal)	P → S
5	OPH	-	#
6	/RXD	Shorting between pins 6 and 7 produces a terminal resistance of 220 Ω between RXD and /RXD.	
7	RT		
8	5VPP	-	#
9	GND	Signal ground 0 V	

3

4

Using Serial Communications

This chapter explains the specifications and commands associated with serial communications. The use of serial communications allows the user to input a variety of commands and set parameters, as well as to monitor SERVOPACK operation, from a personal computer or other device.

4.1	Connecting and Setting Up	
	Serial Communications	4 -2
4.1.1	Overview	4 -2
4.1.2	Wiring to the Host Controller	4 -3
4.1.3	Baud Rate and Command Length Mode Settings	4 -6
4.1.4	Axis Address Settings	4 -8
4.1.5	Axis Number Setting	4 -9
4.1.6	Group Function Setting	4 -9
4.2	Serial Communications Commands	4 -10
4.2.1	Sending Commands to a SERVOPACK	4 -10
4.2.2	Reading Data from a SERVOPACK	4 -12
4.3	Using Fixed Length Mode	4 -17
4.3.1	Calculating the Checksum	4 -17
4.3.2	Handling Communications Errors	4 -17
4.3.3	Data Sent from the SERVOPACK	4 -18
4.4	Serial Commands for Settings and Monitoring	4 -21
4.4.1	List of Commands	4 -21
4.4.2	Command Details	4 -24
4.5	Communications Specifications	4 -32
4.5.1	Hardware Specifications	4 -32
4.5.2	Communications Control Codes	4 -33
4.5.3	Transmission/Reception Timing	4 -33

4.1 Connecting and Setting Up Serial Communications

A SGDB-□□AM SERVOPACK can be connected to a host controller equipped with an RS-422A communications port. This section explains how to connect a SERVOPACK and a host controller using serial communications.

4.1.1 Overview

Whether in a single-axis configuration or multi-axis configuration (up to 32 axes), a SGDB-□□AM SERVOPACK can be operated from a single host controller. In a multi-axis configuration, commands can be sent to each axis separately, to groups of axes, or to all axes at once. The required serial communications settings differ in each case.

■ Single-axis Configuration

A single-axis configuration is like the one shown in the figure on the right. In this case, the initial settings necessary for serial communications are as follows:

- Baud rate and command length mode

A single-axis configuration has the following characteristics:

- The echoback function can be used with commands.
- Automatic data transmission from the SERVOPACK can be used.

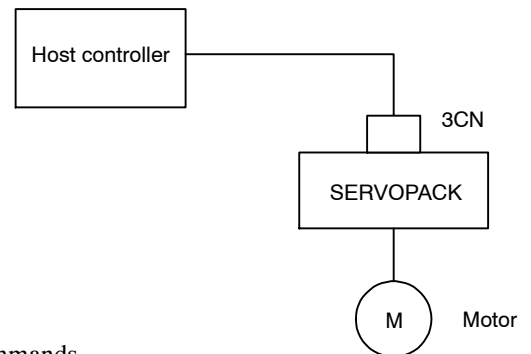

■ Multi-axis Configuration without Groups

A multi-axis configuration is shown in the following figure. In this case, each SERVOPACK is differentiated by an axis address (1 to 15). The initial settings necessary for serial communications are as follows:

- Baud rate and command length mode
- Axis address (axis number only, groups are not used)

A multi-axis configuration without groups possesses the following characteristics:

- Up to 15 axes can be connected. (Electrically, up to 32 axes can be connected, but the number of axes is logically limited to 15.)
- Commands can be sent separately to each axis or to all axes at once.
- The echoback and automatic data transmission functions cannot be used.

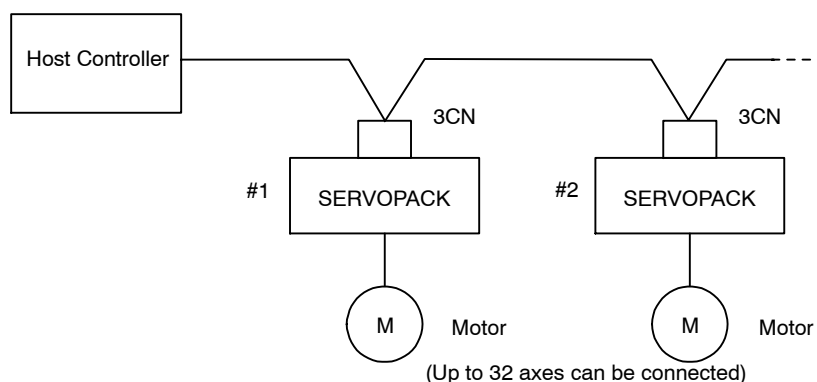

■ Multi-axis Configuration with Groups

The hardware configuration is the same as that of a system that does not use groups, i.e., the same as the one shown above. Each SERVOPACK is differentiated by an address set for each axis (11 to 19, 21 to 29, ... , 91 to 99) The 10's digit is the group number and the 1's digit is the axis number. The initial settings necessary for serial communications are as follows:

- Baud rate and command length mode
- Axis address (both axis number and group number)

A multi-axis configuration with groups possesses the following characteristics:

- One group can contain up to 9 axes, and up to 9 groups can be set, with a maximum of 32 axes possible. (Logically, up to 81 axes can be connected, but electrical specifications limit the number of axes to 32.)
- Commands can be sent separately to each axis, to all axes with the same group number, to all axes with the same axis number, or to all axes at once.
- The echoback and automatic data sending functions cannot be used.

4.1.2 Wiring to the Host Controller

The method of wiring to the host controller with an RS-422A interface and personal computers with an RS-232C interface is explained in this section for each system configuration. When an RS-232C interface is used, limit the cable length to 2 meters or less, and connect only one axis.

■ Single-axis Configuration (RS-422A)

Wire as shown in the following figure.

If the cable is too long, it may be necessary to insert a terminating resistor.

The addition of a terminating resistor generally improves resistance to noise and other interference.

When required, insert a terminating resistor between the RXD and /RXD of the host controller and the RXD and /RXD of the SERVOPACK. The SERVOPACK has a built-in terminating resistor (220 Ω), and shorting between 3CN-6 and 3CN-7 will connect it to the circuit.

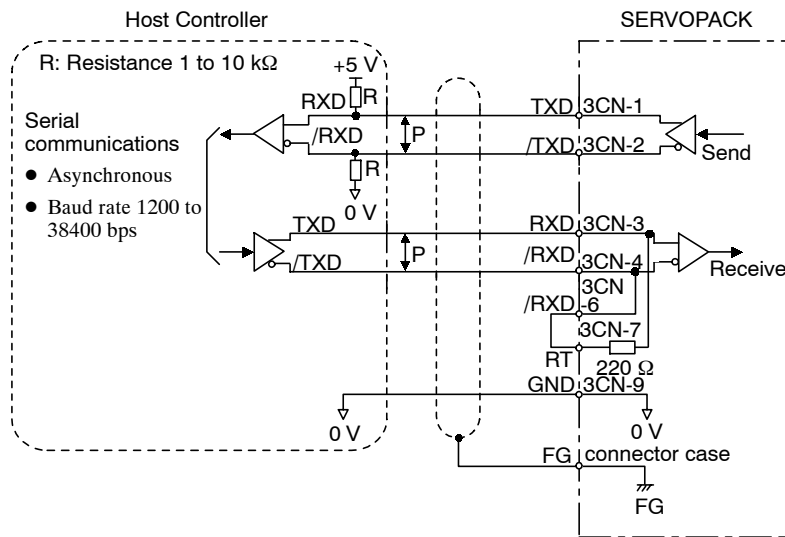

Note: $\overline{\text{P}}$ indicates twisted-pair cable.

■ Multi-axis Configuration (RS-422A)

Wire as shown in the following figure.

If the cable is too long, it may be necessary to insert a terminating resistor.

The addition of a terminating resistor generally improves resistance to noise and other interference.

When required, insert a terminating resistor between the RXD and /RXD of the host controller and the RXD and /RXD of the last SERVOPACK (the SERVOPACK furthest from the host controller).

The SERVOPACK has a built-in terminating resistor, and shorting between 3CN-6 and 3CN-7 will connect it to the circuit.

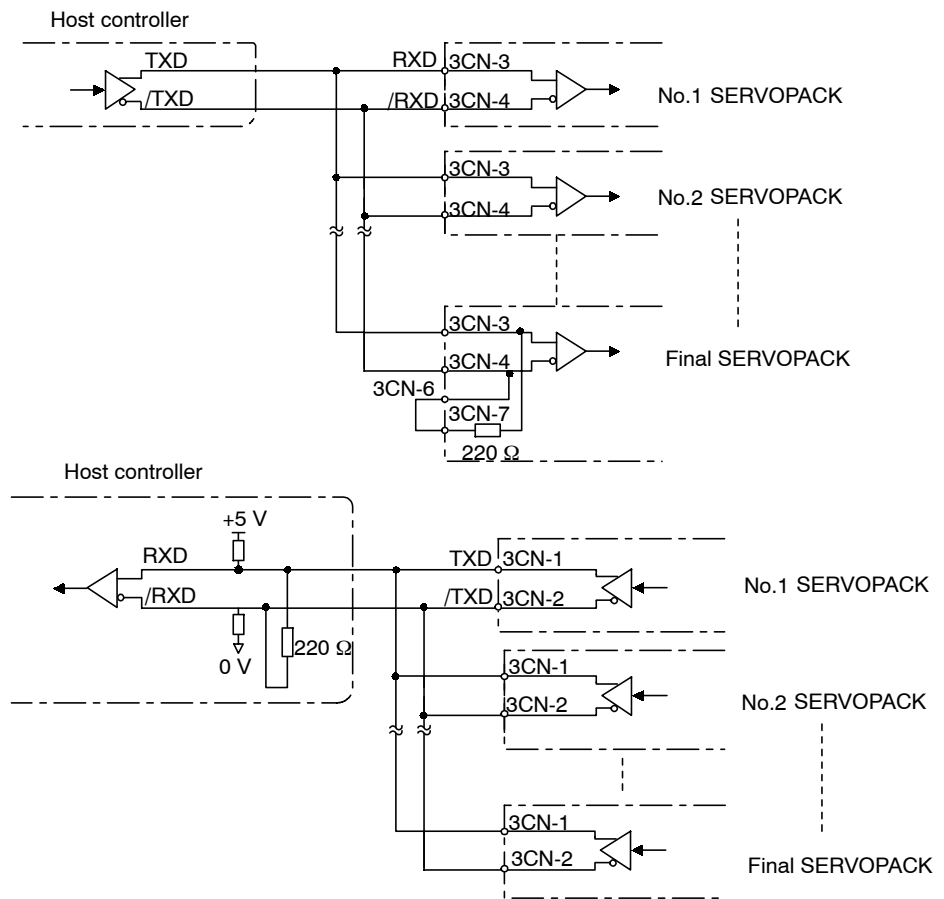

■ **Connecting to a Personal Computer (RS-232C)**

Wire as shown in the following figure, making sure the length of the cable does not exceed 2 meters.

The following dedicated cables are available from Yaskawa.

For IBM PC/AT or compatible computer: DE9408565

Electrical characteristics can sometimes prevent communications with a SERVOPACK from an RS-232C port, even if the wiring is correct and Yaskawa cables are used. In such cases, use a commercially available RS-232C ↔ RS-422A converter, and connect to an RS-422A port.

Connecting to IBM PC/AT (or Compatible)

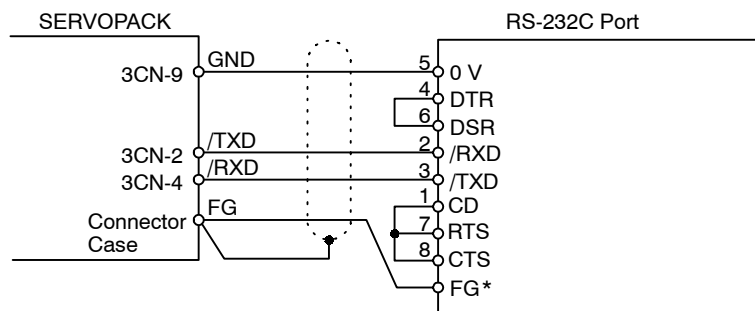

Personal computer-end connector 17JE-13090-02(08A) manufactured by Daiichi Electronic Industries, Ltd, or an equivalent product.

* Connect FG to connector case.

■ 3CN I/O Signals

Table 4.1 Terminal Arrangement

1	TXD	Serial communications line driver straight output	6	/RXD	Serial communications line receiver inverted input
2	/TXD	Serial communications line driver inverted output	7	RT	Terminating resistor
3	RXD	Serial communications line receiver straight input	8	5VPP	Digital Operator power supply
4	/RXD	Serial communications line receiver inverted input	9	GND	0 V for signal
5	OPH	Signal for Digital Operator			

Table 4.2 Terminal Functions

Output → TXD	3CN-1	Data sending signal from the SERVOPACK when using serial communications conforming to RS-422A specifications. When data is not being sent, the signal lines have high impedance.
Output → /TXD	3CN-2	
→ Input RXD	3CN-3	Data receiving signal from the host controller (personal computer, etc.) when using serial communications conforming to RS-422A specifications.
→ Input /RXD	3CN-4	
→ Input OPH	3CN-5	Digital Operator signal. Do not connect.
→ Input /RXD	3CN-6	Shorting terminals 3CN-6 and 3CN-7 connects terminating resistance to the serial input circuit of the SERVOPACK. Insert terminating resistance into the SERVOPACK at the end of the serial line (i.e., furthest from host controller).
→ Input RT	3CN-7	
Output → 5VPP	3CN-8	+5 V power supply output for Digital Operator. Do not connect.
Output → SG	3CN-9	Ground for /TXD, TXD, /RXD, and RXD signals.

4.1.3 Baud Rate and Command Length Mode Settings

Set the baud rate and command length mode according to the host controller settings.

The SGDB-□□AM SERVOPACK supports two command modes.

Normal mode: This mode maintains compatibility with CACR-HR SERVOPACKs.

Fixed length mode: The length of commands and the SERVOPACK responses are fixed at three characters, and a checksum is added. Also, communications errors are classified in more detail than in normal mode. Refer to *4.3 Using Fixed Length Mode*.

■ Baud Rate and Command Length Mode Settings

The 2SW is used to set the baud rate and command length mode.

2SW	Baud Rate and Command Length Mode	Setting Range	Factory Setting
		0 to F	0

2SW	Baud Rate	Command Length Mode
0	38400 bps	Standard Length Mode
1	19200 bps	
2	9600 bps	
3	4800 bps	
4	2400 bps	
5	1200 bps	
6	-	
7	-	-
8	38400 bps	Fixed Length Mode
9	19200 bps	
A	9600 bps	
B	4800 bps	
C	2400 bps	
D	1200 bps	
E	-	
F	-	-

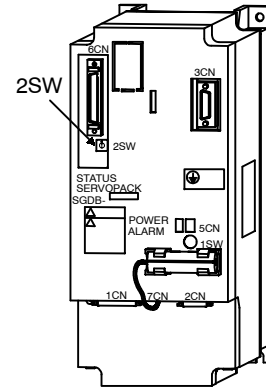

Note: Do not set 6, 7, E, and F, as functions may be assigned to these settings without prior notice.

4.1.4 Axis Address Settings

When an SGDB-□□AM SERVOPACK operates as part of a multi-axis configuration system, it is assigned an axis address. Commands sent to SERVOPACKs can also contain an axis address. In this way, it is possible to send commands to a particular SERVOPACK or a particular group of SERVOPACKs among those connected in series using serial communications.

The following three settings are used according to the connection method. The maximum number of connected axes and the axis specification functions differ in each method.

Connection Method	Max. No. of Axes Connected	Required Settings			Axis Address Designation			
		Cn-32 Bit 8 (Group Function Enable/Disable Selection)	Cn-13 (Group No.)	1SW (Axis No.)	Single Axis	All Axes	All Axes in Same Group	All Axes with Same Axis Number
Single-axis Configuration	1	0 (Disabled)	No setting required.	0	Axis address designation not required.	–	–	–
Multi-axis Configuration without Groups	15	0 (Disabled)	No setting required.	1 to F (Correspond to axis numbers 1 to 15.)	1 to 15	0 or 00 or axis address omitted.	–	–
Multi-axis Configuration with Groups	32 (See note)	1 (Enabled)	1 to 9	1 to 9	11 to 19, 21 to 29, ..., 91 to 99	0 or 00 or axis address omitted.	10, 20, ..., 90	01, 02, ..., 09

Note: Up to 81 logical axes can be connected, but the electrical specifications of the serial circuit limit the number of physical axes to 32.

■ Axis Addresses in a Single-axis Configuration

There are no axis addresses.

No axis address is included in a command when it is sent.

■ Axis Addresses in a Multi-axis Configuration without Groups

The axis address is determined by the axis number only.

Commands can be sent to a single axis address or to all axes.

■ Axis Addresses in a Multi-axis Configuration with Groups

The axis address contains an axis number and a group number.

The lower-place digit of the axis address is the axis number and the higher-place digit is the group number.

Commands can be sent to a single axis address, to all axes with the same axis number (the lower-place digit of the axis address), to all axes with the same group number (the higher-place digit of the axis address), or to all axes regardless of the axis address.

4.1.5 Axis Number Setting

The axis number is set using the rotary switch described below.

The axis address is enabled or disabled using this rotary switch.

1SW	Axis Number	Setting Range	Factory Setting
		0 to F	0

1SW	Content	Remarks
0	Disables axis address	Select when using single-axis configuration.
1 to 9	Sets axis numbers to 1 to 9.	Select when using multi-axis configuration.
A	Sets axis number to 10.	Can be selected only when using multi-axis configuration without groups. (Disable the group function.)
B	Sets axis number to 11.	
C	Sets axis number to 12.	
D	Sets axis number to 13.	
E	Sets axis number to 14.	
F	Sets axis number to 15.	

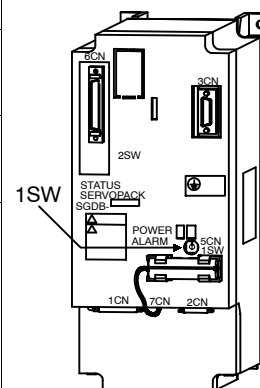

4

4.1.6 Group Function Setting

To use groups, the user needs to enable the group function and set a group number.

Whether to enable or disable the group function is set using the following memory switch bit.

Cn-32 bit 8	Group Function Enable/Disable	Factory Setting
		0

Setting	Content	Remarks
0	Disables group function.	Select when using single-axis configuration and multi-axis configuration without groups.
1	Enables group function.	Set group number in Cn-13 when group function is enabled.

The group number is set using the following parameter.

Cn-13	Group Number	Setting Range	Factory Setting
		1 to 9	1

4.2 Serial Communications Commands

The use of serial commands to operate the SERVOPACK via serial communications is explained in this section using the normal mode as an example. Refer also to *4.3 Using Fixed Length Mode* for information on using commands in fixed length mode.

4.2.1 Sending Commands to a SERVOPACK

Commands are sent as described in this section. If the axis number is omitted in a multi-axis configuration, the command will be sent to all axes.

■ Single-axis Configuration

When sending a command, the axis address is not included.

Commands take the following format:

[Command string][CR]

([CR] indicates a carriage return)

Example:

Commands	Explanation
SVON [CR]	Turns Servo ON.
SPD12000 [CR]	Sets feed speed data to 12000 ($\times 1000$ command units/min).
MOV40000 [CR]	Sets position data to 40000 (command units).
ST [CR]	Starts operation.

■ Multi-axis Configuration without Groups

Commands sent to SERVOPACKs with an axis address M from 1 to 15 have the axis address M included at the beginning of the command. If the axis address is omitted or designated as 0 or 00, the command will apply to all connected SERVOPACKs.

Commands take the following format:

[Axis address][Command string][CR]

(where [CR] indicates a carriage return)

Contents of [Axis Address]	Designated Axis
None, 0, or 00	All axes.
N (N = 1 to 15), 0N (N = 1 to 9)	Axis address N
N (N \geq 16)	None (Axis addresses note between 1 and 15 are ignored.)

Example:

Commands	Explanation
1SVON [CR]	Turns ON Servo with axis address 1.
2SVON [CR]	Turns ON Servo with axis address 2.
0SPD12000 [CR]	Sets feed speed data of all axes to 12000 ($\times 1000$ command units/min).
1MOV40000 [CR]	Sets position data of axis 1 to 40000 (command units).
2MOV20000 [CR]	Sets position data of axis 2 to 20000 (command units).
0ST [CR]	Starts operation at all axes.

■ Multi-axis Configuration with Groups

Commands sent to SERVOPACKs with an axis address have the axis address included at the beginning of the command. The axis address is in the form NM, when N is the group number set in Cn-13 and M is the axis number set on 1SW. All axes or all groups can be specified by using 0 instead of the actual number. For example, specifying 0M would send commands to all SERVOPACKs with axis number M, specifying N0 would send commands to all SERVOPACKs in group number N, and specifying 00 would send commands to all connected SERVOPACKs.

[Axis address][Command string][CR]

([CR] indicates a carriage return)

Contents of [Axis Address]	Designated Axis
None, 0, or 00	All axes
NM (N = 1 to 9, M = 1 to 9)	Axis address NM
0M (M = 1 to 9)	All axes with axis number M
N0 (N = 1 to 9)	All axes with group number N

Example:

Commands	Explanation
11SVON [CR]	Turns ON Servo with axis address 11.
12SVON [CR]	Turns ON Servo with axis address 12.
21SVON [CR]	Turns ON Servo with axis address 21.
10SPD12000 [CR]	Sets feed speed data of all axes in group 1 to 12000 ($\times 1000$ command units/min).
21SPD1000 [CR]	Sets feed speed data of axis at address 21 to 1000 ($\times 1000$ command units/min).
11MOV40000 [CR]	Sets position data of axis at address 11 to 40000 (command units).
12MOV10000 [CR]	Sets position data of axis at address 12 to 10000 (command units).
21MOV10000 [CR]	Sets position data of axis at address 21 to 10000 (command units).
00ST [CR]	Starts operation at all axes.

4.2.2 Reading Data from a SERVOPACK

The SERVOPACK can return data to the host controller based on settings and commands. The following types of data can be returned.

■ Echoback

Echoback returns serially input characters unchanged. It is used to verify the contents of an input, such as when using a serial terminal to send commands to the SERVOPACK manually.

The echoback function is enabled or disabled by sending the control code [Ctrl-E] (05H). To enable or disable the echoback function when the SERVOPACK is started, use the following parameter.

Cn-32 Bit A	Enable/Disable Echoback Function at SERVOPACK Startup	Factory Setting
		0

Setting	Content
0	No echoback
1	Echoback

Echoback only functions in a single-axis configuration, and is not available in a multi-axis configuration.

Echoback does not usually apply to control codes, including [Ctrl-E] itself.

[CR](0DH) is converted to [CR](0DH)+[LF](0AH) and echoed back.

Example: Starting SERVOPACK without Echoback Function

Commands	SERVOPACK Response	Explanation
Control power supply turned ON.		
PRM1 [CR]		Command input
	PRM01 = 0000000000000000 [CR][LF]	SERVOPACK response
[Ctrl-E]		Echoback enabled
PRM2 [CR]	PRM2 [CR][LF]	Command input and echoback
	PRM02 = 0000000000000000 [CR][LF]	SERVOPACK response
[Ctrl-E]		Echoback disabled
PRM2 [CR]		Command input
	PRM02 = 0000000000000000 [CR][LF]	SERVOPACK response

■ Reading SERVOPACK Settings

SERVOPACK settings, such as parameters and tables, will be returned.

The settings will be returned after being set with the PRM, VT, PT or BT command.

Item		Reading Specific Settings	Reading All Settings
Command Format*		<code>[axis_address][command_string]</code> <code>[data_number][CR]</code>	<code>[axis_address][command_string][CR]</code>
Response Data Format		<code>[data_string][CR][LF]</code>	<code>[data_string][CR][LF]</code> <code>[data_string][CR][LF]</code> . . . <code>[data_string][CR][LF]</code>
Ex.1	Command	11VT10 [CR]	11VT [CR]
	SERVOPACK Response	VT010 = 00000001 [CR][LF]	VT001 = 00000001 [CR][LF] VT002 = 00000001 [CR][LF] . . . VT512 = 00000001 [CR][LF]
Ex.2	Command	PRM13 [CR]	PRM [CR]
	SERVOPACK Response	PRM13 = +00000001 [CR][LF]	PRM01 = 0000000010000000 [CR][LF] PRM02 = 0000000000000000 [CR][LF] . . . PRM3F = +00000000 [CR][LF]

* When using single-axis configuration, the axis address can be omitted from the command.

■ Automatic Data Transmission at Events

Automatic data transmissions can be used to notify the user of events, such as positioning completion and alarms.

This data is sent when an event occurs.

In a single-axis configuration, the data is sent automatically.

In a multi-axis configuration, ERR SN, ERR PN, and ERR OV data is sent automatically only in the event of an axis-specific command error. It is not sent when multiple axes are designated.

Sending Conditions		Commands
Once only after positioning completion		COIN [CR][LF]
Once only after positioning near established		NEAR [CR][LF]
Normal command		OK [CR][LF]
When an alarm occurs		A.xx [CR][LF] (xx = alarm code)
Forward overtravel		P-OT [CR][LF]
Reverse overtravel		N-OT [CR][LF]
Stored positive stroke-limit overtravel		P-LS [CR][LF]
Stored negative stroke-limit overtravel		N-LS [CR][LF]
When a command error occurs	Command error (when undefined command is sent)	ERR SN [CR][LF]
	Number error (when the value of p or pp in ALMp, MONp or PRMpp, etc., is incorrect)	ERR PN [CR][LF]
	Data error (when the value of x in PRMpp = x, VTppp = x, etc., is incorrect)	ERR OV [CR][LF]

■ SERVOPACK Status Monitor 1

This current position, errors, speed, and I/O contacts can be monitored.

When requested by a command such as MON, IN or OUT, the current monitor data is returned. Single or continuous transmissions can be set using the following parameter. When continuous transmissions is selected, the transmissions can be stopped by sending any character to the SERVOPACK, or by sending a new command.

Cn-32 Bit C	Monitor Transmissions Single/Continuous	Factory Setting
		0

Setting		0	1
Content		Single transmission	Continuous transmissions
Explanation		Monitor data is sent once only upon receiving a monitor command. [CR][LF] is output after the data string.	<p>The most recent monitor data is sent continuously after receiving a monitor command. [LF] is not added to the data string.</p> <ul style="list-style-type: none"> • Automatic Data Transmission When data is sent automatically during continuous transmissions of monitor data, [LF] is sent before the automatic data transmission. After the automatic data transmission, [CR][LF] is output as usual. • Monitor data is sent until any character, such as a subsequent command, is input. Once a character is input, any data string currently being transmitted will be sent, followed by [CR][LF], terminating continuous transmissions.
Response Data Format		<i>[data_string]</i> [CR][LF]	<i>[data_string]</i> [CR] <i>[data_string]</i> [CR] . . . <i>[data_string]</i> [CR] [LF] COIN [CR][LF] <i>[data_string]</i> [CR] . . . <i>[data_string]</i> [CR][LF]
Ex.	Command	11MON0 [CR]	11MON0 [CR]
	SERVOPACK Response	NFB = +00000 [CR][LF]	NFB = +00400 [CR] NFB = +00401 [CR] . . . NFB = +00003 [CR] NFB = +00001 [CR] [LF] COIN [CR][LF] NFB = +00000 [CR] . . . NFB = +00000 [CR][LF]

■ SERVOPACK Status Monitor 2

The current alarm status, alarm history, and the SERVOPACK operating status (motor ON/OFF status, positioning status, etc.) can be monitored.

When requested by an ALM command, the current status is returned once only.

Command	Function	SERVOPACK Status	Returned Contents
ALM	Requests SERVOPACK status.	When motor is OFF	BB[SP][SP][CR][LF] ([SP] refers to a single space character)
		When motor is ON	RUN [SP][CR][LF]
		When motor is running	TURN [CR][LF]
		Positioning completed	COIN [CR][LF]
		Positioning near	NEAR [CR][LF]
		During feed hold	HOLD [CR][LF]
		When overtravel occurs	P-OT [CR][LF] N-OT [CR][LF]
		When stored stroke-limit overtravel occurs	P-LS [CR][LF] N-LS [CR][LF]
When alarm occurs	A.xx (where xx is the alarm code)[CR][LF]		
ALMp (p = 0 to 9)	Requests alarm trace back (content of p th previous alarm). If p = 0, the current alarm status is requested. The SERVOPACK stores up to nine previous alarms. If an alarm had occurred previously when power to the SERVOPACK is turned ON, the alarm code A.99 (the alarm code signifying that there is no alarm) is stored in memory.	Ap-A.xx [CR][LF]	Indicates that the p th previous alarm code is xx. When p = 0, xx is the current alarm code.

Note: In this case, the command spelling is the same for the normal mode and fixed length mode.

4.3 Using Fixed Length Mode

Fixed length mode is selected with 2SW. For an explanation of 2SW, refer to *4.1.3 Baud Rate and Command Length Mode Settings*.

In fixed length mode, the length of commands and the SERVOPACK responses are fixed at three characters, and a checksum is added. Also, communications errors are classified in more detail than in normal mode.

Fixed length mode is used when sending serial commands from a personal computer or a Serial I/O Module of a PLC, and stricter error checking is required.

4.3.1 Calculating the Checksum

The checksum in fixed length mode is calculated by changing the sum of each character code into a hexadecimal number, the lower byte of the number is added to the command as two characters.

Example: SERVO ON command (SON)

SONF0

The character code of “S” is 83 (53 Hex), the character code of “O” is 79 (4F Hex), and the character code of “N” is 78 (4E Hex), the checksum of the SON command is thus $83 + 79 + 78 = 240$. 240 is F0 Hex. The checksum F0 will be added to the command SON.

When the hexadecimal value of the checksum is 100 Hex or greater, only the lower two digits of the checksum are added. For example, if the checksum is 1234 Hex, 34 will be added.

The checksum calculation ignores the parity bit.

4.3.2 Handling Communications Errors

The SERVOPACK generates the following error codes when communicating in fixed length mode.

Error Name	Error Code
Communications error	E1
Command error	E2
Number error	E3
Data error	E4
Command sum error	E5

A communications error will occur for a parity error, an overrun error, or a framing error.

A command sum error will occur for a sum check error.

Command errors, number errors, and data errors occur under the same conditions as ERR SN, ERR PN, and ERR OV in normal mode. Refer to 4.2.2 *Reading Data from a SERVOPACK*.

■ Outputting SERVOPACK Communications Errors

When a communications error is detected, the SERVOPACK outputs the error as described below.

The 7-segment LED displays “E.” and /ERR = L, /AL3 = L, /AL2 = L, /AL1 = L, and /AL0 = H. For a single-axis configuration, the automatic data transmission ERRxx**[CR][LF] (underlined portion represents checksum) that indicates the error will be output from the serial port. For a multi-axis configuration, the SERVOPACK that detected the error will output three characters of a brake signal from the serial port.

Output Device		Output for Communications Error
7-segment LED		E.
Contact Output	/AL0 (6CN-6)	H
	/AL1 (6CN-7)	L
	/AL2 (6CN-8)	L
	/AL3 (6CN-9)	L
	/ERR (6CN-27)	L
Serial Output	Single-axis Configuration (Automatic Data Transmission)	<u>ERRxx**</u> [CR][LF] (underlined portion represents checksum)
	Multi-axis Configuration	Three characters of brake signal

■ Clearing Communications Errors

A communications error is cleared if any of the following occurs.

- A normal command is received.
- Power to the SERVOPACK is turned ON again.
- The SERVOPACK is reset.

4.3.3 Data Sent from the SERVOPACK

In the following explanation, underlined portions indicate the checksum.

■ Automatic Data Transmission

In a single-axis configuration, the data automatically output by the SERVOPACK is as shown below.

SERVOPACK State	Automatically Sent Data
Positioning complete	CIND <u>A</u> [CR][LF]
Positioning near	NER <u>E5</u> [CR][LF]
Normal command	OK, <u>C8</u> [CR][LF]
Alarm occurred	ALM <u>xx**</u> [CR][LF]
Error occurred	ERR <u>xx**</u> [CR][LF]
Forward overtravel	POT <u>E3</u> [CR][LF]
Reverse overtravel	NOT <u>E1</u> [CR][LF]
Stored positive stroke limit overtravel	PLSE <u>F</u> [CR][LF]
Stored negative stroke limit overtravel	NLSE <u>D</u> [CR][LF]

■ Responses to Commands

The responses to commands are shown below. For commands not shown below, normal mode responses with a checksum will be returned.

Command and SERVOPACK States		Response
ALM Command	Servo OFF and no alarm	BLKD <u>9</u> [CR][LF]
	Servo ON and positioning completed	CIND <u>A</u> [CR][LF]
	Servo ON and positioning near	NEAE <u>5</u> [CR][LF]
	Servo ON and motor rotating	TRNE <u>4</u> [CR][LF]
	Servo ON and feed hold	HLDD <u>8</u> [CR][LF]
	Servo ON and none of the above	RUN <u>F5</u> [CR][LF]
	Forward overtravel	POTE <u>3</u> [CR][LF]
	Reverse overtravel	NOTE <u>1</u> [CR][LF]
	Forward stored stroke limit exceeded	PLSE <u>F</u> [CR][LF]
	Reverse stored stroke limit exceeded	NLSE <u>D</u> [CR][LF]
	Alarm occurred	ALM <u>xx**</u> [CR][LF]
	Error occurred	ERR <u>xx**</u> [CR][LF]
SAVE command sent	SAVE <u>A</u> [CR][LF]	
ALMp Command		ALMp = <u>xx**</u> [CR][LF]
PTB, PTBppp Command		PTBppp = \pm nnnnnnn <u>**</u> [CR][LF]
VTB, VTBppp Command		VTBppp = nnnnnn <u>**</u> [CR][LF]

4.3.3 Data Sent from the SERVOPACK

Command and SERVOPACK States	Response
BTB, BTBppp Command	BTBppp = ± nnnnnnnn** [CR][LF]

4.4 Serial Commands for Settings and Monitoring

It is possible to set parameters and tables using serial commands, and to monitor the state of the SERVOPACK.

For information on serial commands relating to motor operation, refer to *3.6 Automatic Mode: Serial Communications*.

Note: "Read" in the descriptions of the servo commands means that the SERVOPACK will return the data requested by the command. The returned data must be processed as required in the host application program.

4.4.1 List of Commands

Type	Normal Mode	Meaning
	Fixed Length Mode	
Parameters	PRM	Reads all parameters.
	PRM	
	PRMpp	Reads parameter number pp.
	PRMpp	
	PRMpp = (±)nnnnnnnn	Changes parameter pp to (±)nnnnnnnn.
	PRMpp = (±)nnnnnnnn	
	TRMpp = (±)nnnnnnnn	Changes parameter pp to (±)nnnnnnnn temporarily.
	TRMpp = (±)nnnnnnnn	

Type	Normal Mode	Meaning
	Fixed Length Mode	
Tables	PT	Reads all position table settings.
	PTB	
	PTppp	Reads position table setting at ppp (where ppp is the number in the table).
	PTBppp	
	PTppp = (±)nnnnnnnn	Changes the position table setting of ppp to (±)nnnnnnnn (where ppp is the number in the table).
	PTBppp = (±)nnnnnnnn	
	VT	Reads all speed table settings.
	VTB	
	VTppp	Reads speed table setting of ppp (where ppp is the number in the table).
	VTBppp	
	VTppp = nnnnnn	Changes the speed table setting of ppp to nnnnnn (where ppp is the number in the table).
	VTBppp = nnnnnn	
	BT	Reads all boundary table settings.
	BTB	
	BTppp	Reads boundary table settings of ppp (where ppp is the number in the table).
	BTBppp	
	BTppp = (±)nnnnnnnn	Changes the boundary table settings of ppp to (±)nnnnnnnn (where ppp is the number in the table).
	BTBppp = (±)nnnnnnnn	
Saving Data	SAVE	Copies and saves the parameters and table settings from back-up memory to flash memory.
	SAV	
	LOAD	Reads the parameters and table settings from flash memory into back-up memory.
	LOD	
	INIT	Initializes the parameters and table settings in back-up memory.
	INT	

Type	Normal Mode	Meaning
	Fixed Length Mode	
Monitoring	MONn	Reads monitor data, such as the current position, error, speed, and I/O status.
	MONn	
	MTY	Reads the SERVOPACK capacity.
	MTY	
	YSP	Reads the Y specification (a special specification) of the SERVOPACK. The Y specification of a standard product is 0.
	YSP	
	ALM	Reads the current operational status.
	ALM	
	ALMp	Reads the p th previous alarm data (p = 0 to 9). When p = 0, the current alarm data is sent.
	ALMp	
	ATC	Deletes alarm data.
	ATC	
	SFT1	Reads the software version number in the main CPU software version.
	SFT1	
	SFT2	Reads the software version number in the servo CPU software version.
	SFT2	

4.4.2 Command Details

Note: "Read" in the descriptions of the servo commands means that the SERVOPACK will return the data requested by the command. The returned data must be processed as required in the host application program.

■ Parameter Manipulation Commands

Command Top line: Normal Bottom line: Fixed length	Function and Contents (Examples Apply to Normal Mode)
PRM PRM	This command reads all the parameters from the SERVOPACK. Example: Command Response from SERVOPACK PRM → PRM01 = nnnnnnnn PRM02 = nnnnnnnn PRM3F = nnnnnnnn
PRMpp PRMpp pp = 01 to 3F	This command reads the contents of parameter pp from the SERVOPACK. Used to check the contents of a particular parameter. Example: Command Response from SERVOPACK PRM30 → PRM30 = nnnnnnnn
PRMpp = ± nnnnnnnn PRMpp = ± nnnnnnnn pp = 01 to 3F nnnnnnnn = -99999999 to +99999999 ("+" can be omitted)	This command changes parameter number pp to ± nnnnnnnn. When changing to a positive number, "+" can be omitted. When rewriting an offline parameter, either execute the RES command after this command, or turn OFF and ON the control power supply to apply the new value.
TRMpp = ± nnnnnnnn TRMpp = ± nnnnnnnn pp = 01 to 3F nnnnnnnn = -99999999 to +99999999 ("+" can be omitted)	This command temporarily changes online parameter number pp. The command syntax is identical to "PRMpp =", however offline parameters cannot be changed. When the control power supply is turned OFF and then ON or the RES command is executed, the settings made by this command revert to those set with "PRMpp =."

■ Table Manipulation Commands

Command Top line: Normal Bottom line: Fixed length	Function and Contents (Examples Apply to Normal Mode)
PT PTB	This command reads all data in the position table from the SERVOPACK. Example: Command Response from SERVOPACK PT → PT001 = ± nnnnnnnn PT002 = ± nnnnnnnn PT512 = ± nnnnnnnn
PTppp PTBppp ppp = 1 to 512	The position data of position number ppp is returned from the SERVOPACK. Example: Command Response from SERVOPACK PT129 → PT129 = ± 00000000
PTppp = ± nnnnnnnn PTBppp = ± nnnnnnnn ppp = 1 to 512 nnnnnnnn = -99999999 to +99999999 (“+” can be omitted)	This command changes table position number ppp to ± nnnnnnnn. When changing to a positive number, “+” can be omitted. Either execute the RES command after this command, or turn OFF and ON the control power supply to apply the new value. (Unit: Command unit)
VT VTB	This command reads all data in the speed table from the SERVOPACK. Example: Command Response from SERVOPACK VT → VT001 = nnnnnn VT002 = nnnnnn VT512 = nnnnnn
VTppp VTBppp ppp = 1 to 512	The speed data of position number ppp is returned from the SERVOPACK. Command Response from SERVOPACK VT129 → VT129 = 000001
VTppp = nnnnnn VTBppp = nnnnnn ppp = 1 to 512 nnnnnn = 1 to 240000	This command changes speed table position number ppp to nnnnnn. Either execute the RES command after this command, or turn OFF and ON the control power supply to apply the new value. (Unit: × 1000 command unit/min.)

Command Top line: Normal Bottom line: Fixed length	Function and Contents (Examples Apply to Normal Mode)
BT BTB	This command reads all boundary positions from the SERVOPACK. Example: Command Response from SERVOPACK BT → BT001 = ± nnnnnnnn BT002 = ± nnnnnnnn BT511 = ± nnnnnnnn
BTppp BTBppp ppp = 1 to 511	The boundary position of boundary number ppp is returned from the SERVOPACK. Example: Command Response from SERVOPACK BT129 → BT129 = ± 00000000
BTppp = ± nnnnnnnn BTBppp = ± nnnnnnnn ppp = 1 to 511 nnnnnnnn = -99999999 to +99999999 (“+” can be omitted)	This command changes boundary position number ppp to ± nnnnnnnn. When changing to a positive number, “+” can be omitted. (Unit: Command unit) Either execute the RES command after this command, or turn OFF and ON the control power supply to apply the new value. It is necessary to set the boundary position so that $BT001 \leq BT002 \leq BT003 \leq \dots \leq BT511$. If only BT001 to BT006 are to be used, BT007 to BT511 are set to +99999999.

■ Data Management Commands

Command Top line: Normal Bottom line: Fixed length	Function and Content (Examples apply to normal mode)
SAVE SAV	Writes data from parameters, position tables, speed tables, and boundary tables to flash memory. <ul style="list-style-type: none"> • The data is stored in memory that has a battery back-up, so if the battery voltage is too low when the control power supply is turned OFF, the data may be lost. • By storing data in flash memory with this command, the data can be restored even if the back-up battery voltage is insufficient when power is turned OFF. • During SAVE command execution, do not turn OFF the control power supply or reset. The data may not be written normally.
LOAD LOD	Reads the data stored in the flash memory by the SAVE command into the back-up memory. <ul style="list-style-type: none"> • Data stored in the back-up memory before the LOAD command was executed is overwritten by the data read from the flash memory. • With the exception of on-line parameters, the data read by the LOAD command is applied using the RES command, or by turning OFF and ON the control power supply. • When the data has not been written normally by the SAVE command (e.g., when the control power supply turned OFF during SAVE command execution), do not use the LOAD command. Data stored in the back-up memory will be lost.
INIT INT	Returns all parameters and table settings to their default values (the factory settings). <ul style="list-style-type: none"> • Only the contents of the back-up memory are returned to their initial values. This command has no effect on flash memory.

Note: During a command error, ERR PN and ERR OV are not indicated.

■ Monitoring Commands

Commands (Normal and Fixed Length Mode)	Function	Response (Normal and Fixed Length Mode)	Units
MON0	Motor speed	NFB = ± nnnnn	min ⁻¹
MON1	Command speed	NRF = ± nnnnnn	× 1000 command units/min
MON2	Torque command	TRF = ± nnn	%
MON3	Number of pulses from phase-U edge	UEP = ± nnnn	No. of encoder pulses (× 4)
MON4	Motor electrical angle	EAG = nnn	deg

Commands (Normal and Fixed Length Mode)	Function	Response (Normal and Fixed Length Mode)	Units
MON5	Internal status 1 (discussed later)	ST1 = b ₁₈ b ₁₇ b ₁₆ ...b ₀	Bit
MON6	Internal status 2 (discussed later)	ST2 = b ₇ b ₆ b ₅ ...b ₀	Bit
MON7	Command pulse speed	PRF = ± nnnnn	× 1000 com- mand units/min.
MON8	Position error	PER = ± nnnnnnnn	Command unit
MON9	Command counter	RCN = nnnnn	Command unit
MONA	Internal status 3 (described later)	IN1 = b ₁₁ b ₁₀ b ₉ ...b ₀	Bit
MONB	Internal status 4 (described later)	IN2 = b ₁₅ b ₁₄ b ₁₃ ...b ₀	Bit
MONC	Internal status 5 (described later)	OU1 = b ₁₃ b ₁₂ b ₁₁ ...b ₀	Bit
MOND	DG-SW setting (position command)	DS1 = ± nnnnnnnn	Command unit
MONE	DG-SW setting (speed command)	DS2 = nnnnnn	× 1000 com- mand units/min
MONF	Current position	PUN = ± nnnnnnnn	Command unit

Note: "DG-SW" refers to digital switch.

Bit Indications: Internal Status 1 (MON5)

Bit	When Set to 0	When Set to 1
b ₀	/ALM (1CN-22, 23) = L (Contact ON)	/ALM (1CN-22, 23) = H (Contact OFF)
b ₁	Dynamic brake is not operating	Dynamic brake is operating
b ₂	Forward rotation mode	Reverse rotation mode
b ₃	Motor rotating (Contact ON)	Motor stopping (Contact OFF)
b ₄	Positioning not completed	Positioning completed
b ₅	Speed loop PI control	Speed loop P control
b ₆	/P-CL (1CN-33) = L (ON)	/P-CL (1CN-33) = H (OFF)
b ₇	/N-CL (1CN-34) = L (ON)	/N-CL (1CN-34) = H (OFF)
b ₈	Base block in progress	Motor ON
b ₉	Phase A of PG = L	Phase A of PG = H

Bit	When Set to 0	When Set to 1
b ₁₀	Phase B of PG = L	Phase B of PG = H
b ₁₁	Phase C of PG = L	Phase C of PG = H
b ₁₂	Phase U of PG = L	Phase U of PG = H
b ₁₃	Phase V of PG = L	Phase V of PG = H
b ₁₄	Phase W of PG = L	Phase W of PG = H
b ₁₅	/S-ON (1CN-28) = L (ON)	/S-ON (1CN-28) = H (OFF)
b ₁₆	/P-CON (1CN-29) = L (ON)	/P-CON (1CN-29) = H (OFF)
b ₁₇	P-OT (1CN-30) = L (ON)	P-OT (1CN-30) = H (OFF)
b ₁₈	N-OT (1CN-31) = L (ON)	N-OT (1CN-31) = H (OFF)

Bit Indications: Internal Status 2 (MON6)

Bit	When Set to 0	When Set to 1
b ₀	CA = L, /CA = H	CA = H, /CA = L
b ₁	CB = L, /CB = H	CB = H, /CB = L
b ₂	CC = L, /CC = H	CC = H, /CC = L
b ₃	Current is not restricted (Contact OFF)	Current is restricted (Contact ON)
b ₄	Brake is applied (Contact OFF)	Brake is released (Contact ON)
b ₅	No overload warning (Contact OFF)	Overload warning (Contact ON)
b ₆	Main circuit power is OFF	Main circuit power is ON.
b ₇	Servo not ready (Contact OFF)	Servo ready (Contact ON)

Bit Indications: Internal Status 3 (MONA)

Bit	When monitor bit is 0, contact is OFF and input is high.
	When monitor bit is 1, contact is ON and input is low.
b ₀	/ZRN (6CN-13)
b ₁	/MAN (6CN-14)
b ₂	/PULS (6CN-15)
b ₃	/MCW (6CN-16)
b ₄	/MCCW (6CN-17)
b ₅	/RST (6CN-18)

Bit	When monitor bit is 0, contact is OFF and input is high.
	When monitor bit is 1, contact is ON and input is low.
b ₆	/SP2ND (6CN-19)
b ₇	SP3RD (6CN-20)
b ₈	/LPG (6CN-21)
b ₉	/AST (6CN-22)
b ₁₀	/ALMRST (6CN-23)
b ₁₁	/STOP (6CN-24)

Bit Indications: Internal Status 4 (MONB)

Bit	When monitor bit is 0, contact is OFF and input is high.
	When monitor bit is 1, contact is ON and input is low.
b ₀	/CD0 (6CN-33)
b ₁	/CD1 (6CN-34)
b ₂	/CD2 (6CN-35)
b ₃	/CD3 (6CN-36)
b ₄	/CD4 (6CN-37)
b ₅	/CD5 (6CN-38)
b ₆	/CD6 (6CN-39)
b ₇	/CD7 (6CN-40)
b ₈	/CD8 (6CN-41)
b ₉	/CD9 (6CN-42)
b ₁₀	/CD10 (6CN-43)
b ₁₁	/CD11 (6CN-44)
b ₁₂	/DR0 (6CN-45)
b ₁₃	/DR1 (6CN-46)
b ₁₄	/PS0 (6CN-47)
b ₁₅	/PS1 (6CN-48)

Bit Indications: Internal Status 5 (MONC)

Bit	When monitor bit is 0, contact is ON and output is low.
	When monitor bit is 1, contact is OFF and output is high.
b ₀	/AUT-LT (6CN-2)
b ₁	/MAN-LT (6CN-3)
b ₂	/POS1 (6CN-4)
b ₃	/POS2 (6CN-5)
b ₄	/AL0 (6CN-6)
b ₅	/AL1 (6CN-7)
b ₆	/AL2 (6CN-8)
b ₇	/AL3 (6CN-9)
b ₈	/ERR (6CN-27)
b ₉	/P0 (6CN-28)
b ₁₀	/P1 (6CN-29)
b ₁₁	/P2 (6CN-30)
b ₁₂	/P3 (6CN-31)
b ₁₃	/P4 (6CN-32)
MTY MTY	Reads the SERVOPACK capacity.
YSP YSP	Reads the Y specification (special specification) of the SERVOPACK. For standard products, the Y specification is 0.
ALM ALM	Reads the current operational status.
ALMp ALMp	Reads the p th previous alarm data (p=0 to 9). When p=0, the current alarm data is sent.
ATC ATC	Deletes the alarm data.
SFT1 SFT1	Reads the software version number in the main CPU software version.
SFT2 SFT2	Reads the software version number in the servo CPU software version.

4.5 Communications Specifications

4.5.1 Hardware Specifications

The serial communications specifications of the SERVOPACK are shown below.

Item	Specifications
Applicable Standard	RS-422A
Communications Method	Asynchronous (ASYNC)
Baud Rate	1200 to 38400 bps (Initial setting: 38400 bps) Set using rotary switch 2SW.
Start Bits	1 bit
Data Bits	7 bits, JIS 7 bits (JIS X0201, formerly C6220)
Parity	1 bit, even
Stop Bits	1 bit
Flow Control	XON/XOFF control

Structure of 1 Character

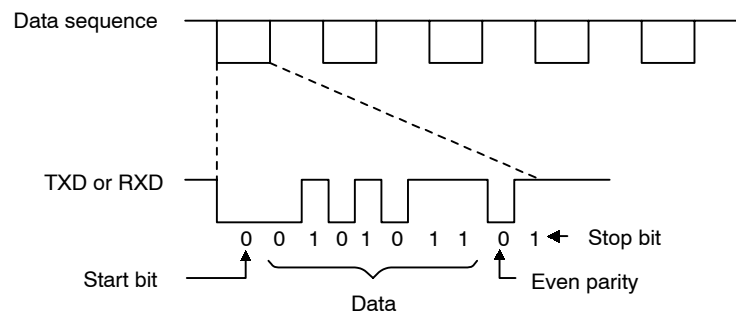

4.5.2 Communications Control Codes

The control codes that can be used in serial communications with the SERVOPACK are shown below.

Control Code	Content
DC3 (Ctrl-S, 13H)	X-OFF (Stop transmission)
DC1 (Ctrl-Q, 11H)	X-ON (Restart transmission)
EXT (Ctrl-C, 03H)	Transmission is interrupted while monitor data is being returned from the SERVOPACK. (To restart, send a monitor command to the SERVOPACK again.)
ENQ (Ctrl-E, 05H)	Enables/disables the echoback function. (The initial state at start-up is determined by bit A of Cn-32. Echoback functions only in a single-axis configuration, and cannot be used in a multi-axis configuration.)
SOH (Ctrl-A, 01H)	Initializes the serial command buffer. All input after the final [CR] is void.

4.5.3 Transmission/Reception Timing

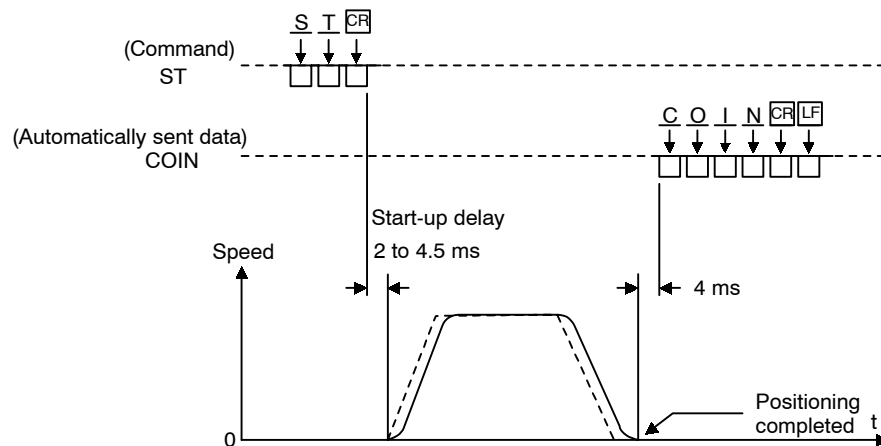

5

Using the Digital Operator

This chapter describes the basic operation of the Digital Operator and the convenient features it offers.

All parameter settings and motor operations are possible by simple, convenient, operation.

Operate the Digital Operator as you read through this chapter.

5.1 Basic Operation	5 -2
5.1.1 Connecting the Digital Operator	5 -2
5.1.2 Precaution If Connecting/Disconnecting the Digital Operator	5 -2
5.1.3 Digital Operator Functions	5 -3
5.1.4 Resetting Servo Alarms	5 -4
5.1.5 Basic Functions and Mode Selection	5 -5
5.1.6 Status Display Mode	5 -6
5.1.7 Parameter Setting Mode	5 -8
5.1.8 Position Table Setting Mode	5 -12
5.1.9 Speed Table Setting Mode	5 -14
5.1.10 Boundary Table Setting Mode	5 -15
5.1.11 Monitor Mode	5 -17
5.2 Practical Operation	5 -24
5.2.1 Operation in Alarm Trace-back Mode	5 -24
5.2.2 Operation Using the Digital Operator	5 -27
5.2.3 Autotuning	5 -30
5.2.4 Clearing Alarm Trace-back Data	5 -36
5.2.5 Checking the SERVOPACK Specifications	5 -38
5.2.6 Checking the Software Version	5 -39
5.2.7 Adjusting the Current Detection Offset Manually .	5 -40
5.2.8 Setting the Machine Zero Point	5 -42
5.2.9 Saving Backup Data	5 -45
5.2.10 Reading Backup Data	5 -47
5.2.11 Initializing Backup Data	5 -49

5.1 Basic Operation

This section describes the basic operations using the Digital Operator.

5.1.1 Connecting the Digital Operator

The Digital Operator is available as two models: JUSP-OP02A-1 (Hand-held) and JUSP-OP03A (Mounted).

Each model is connected to the SERVOPACK as shown below.

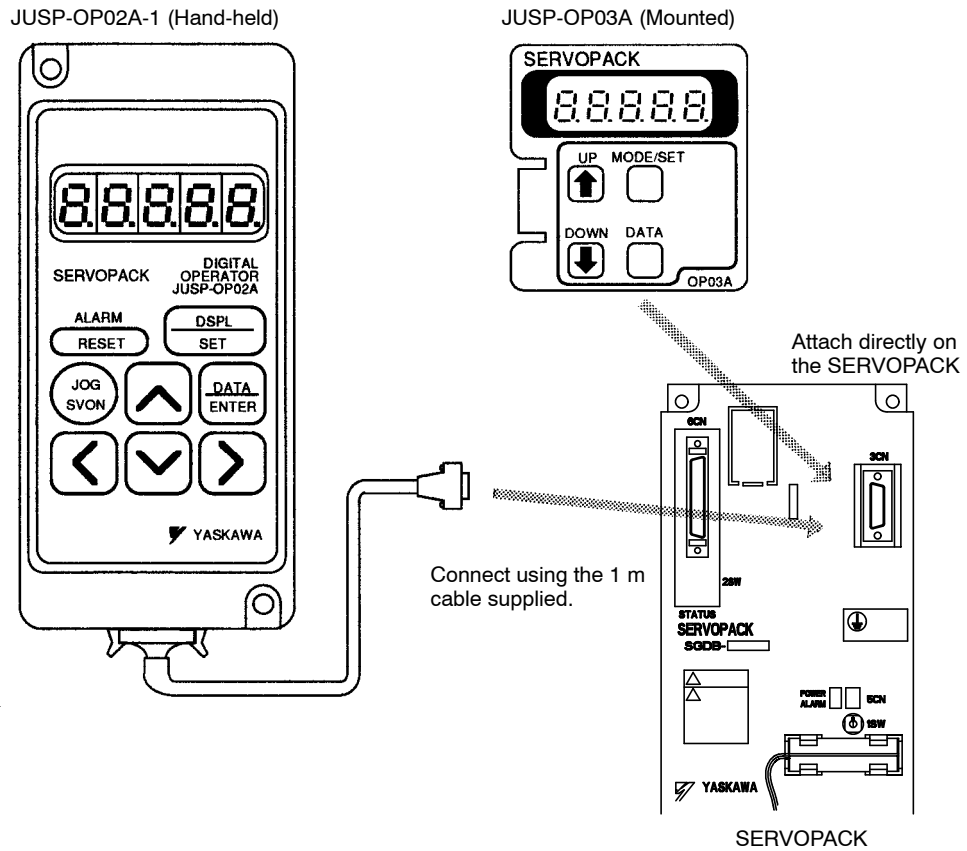

5.1.2 Precaution If Connecting/Disconnecting the Digital Operator

A communication error may occur depending on the order in which the connector pin are touched if the Digital Operator is connected or disconnected with the power supply of the SERVOPACK turned ON.

The error can be cleared or reset by using the mode switch and reading a normal command.

Use the following parameter to mask the /ERR signal in serial communications.

Cn-01 Bit 4	/ERR Signal Mask for Serial Communications	Factory Setting: 0
--------------------	--	--------------------

Setting	Meaning
0	Do not mask the /ERR signal for serial communications.
1	Mask the /ERR signal for serial communications.

5.1.3 Digital Operator Functions

The Digital Operator allows the user to set parameters, send commands, and display operating status.

This section describes the key names and functions of the Digital Operator in the initial display status.

Hand-held Digital Operator

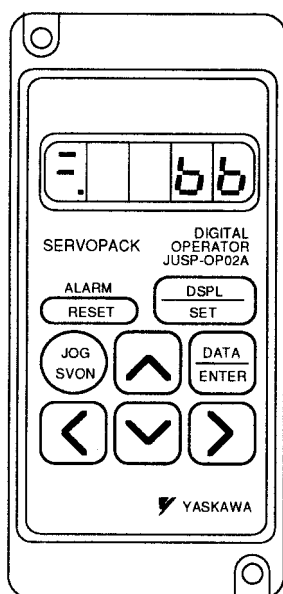

Key	Name	Function
	RESET Key	Press to reset the servo alarm.
	DSPL/SET Key	Press to select the status display mode, setting mode, monitor mode, or error trace-back mode. Used to select data in setting mode.
	DATA/ENTER Key	Press to display the parameter settings and set values.
	Value Change/Jog Keys	Increment/Forward Jog Key Press to increment the set value. Used as a forward start key during jogging.
		Decrement/Reverse Jog Key Press to decrement the set value. Used as a reverse start key during jogging.
	Digit Selection Keys	Digit Down Key Press to select the digit to be changed. The selected digit flashes. The cursor moves right one digit when the Digit Down Key is pressed.
		Digit Up Key The cursor moves left one digit when the Digit Up Key is pressed.
	SVON Key	Press to jog using the Digital Operator.

Mounted Digital Operator

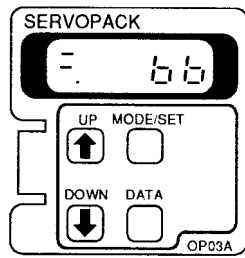

Key	Name	Function
UP ↑	UP Key	Press to display the parameter settings and set values. Pressing the UP Key increments the set value.
DOWN ↓	DOWN Key	Pressing the DOWN Key decrements the set value. Servo alarms can be reset by pressing the UP Key and DOWN Key simultaneously.
MODE/SET □	MODE/SET Key	Press to select the status display mode, setting mode, monitor mode, or error trace-back mode.
DATA □	DATA Key	Press to display the parameter settings and set values. Can be used as a data setting key in the setting mode.

5.1.4 Resetting Servo Alarms

Servo alarms can be reset using the Digital Operator.

Alarms can also be reset using the 6CN-23, /ALMRST input signal.

If the control power supply is turned OFF, the servo alarm need not be reset. Be sure to eliminate the cause of the alarm before resetting it.

For Hand-held Digital Operator, press the RESET Key to reset.

For Mounted Digital Operator, press the UP Key and DOWN Key simultaneously to reset.

5.1.5 Basic Functions and Mode Selection

Digital Operator operation allows operation status display, parameter setting, operating command, and auto-tuning operations.

The basic modes are the status display mode, parameter setting mode, position table setting mode, speed table setting mode, boundary table setting mode, monitor mode, and alarm trace-back mode. When the key is pressed, the next mode in the sequence is selected.

Hand-held Digital Operator

Press the DSPL/SET Key.

The basic mode is switched.

Mounted Digital Operator

Press the MODE/SET Key.

The basic mode is switched.

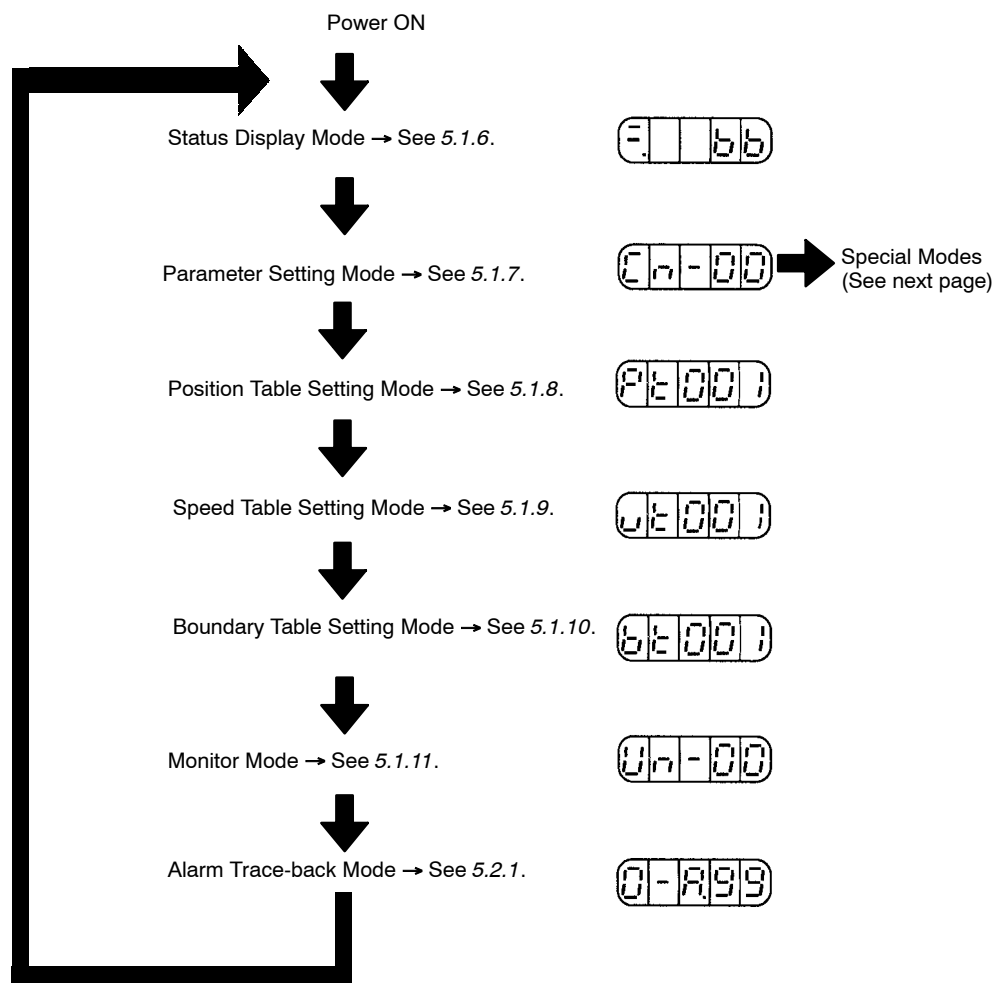

Special Modes

Set a value for parameter Cn-00 to change the sub-mode.

Hand-held Digital Operator: Press the DATA/ENTER Key.

Mounted Digital Operator: Press the DATA Key.

Cn-00 Setting	Overview	Cn-00 Setting	Overview
00-00	Operation using the Digital Operator (see 5.2.2)	00-08	Current detection offset manual adjustment mode (see 5.2.7)
00-02	Clearing alarm trace-back data (see 5.2.4)	00-0A	Machine machine zero point setting mode (see 5.2.8)
00-04	SERVOPACK specification check mode (see 5.2.5)	00-0b	Backup data save mode (see 5.2.9)
00-05	Autotuning mode (see 5.2.3)	00-0C	Backup data read mode (see 5.2.10)
00-06	Software version check mode (see 5.2.6)	00-0d	Backup data initialization mode (see 5.2.11)

5.1.6 Status Display Mode

The status display mode displays the SERVOPACK status as bit data and codes.

■ Selecting the Status Display Mode

The status display mode is displayed when the power is turned ON. If the status display mode is not displayed, use the procedure shown in 5.1.5 *Basic Functions and Mode Selection* to set the status display mode.

■ Display Contents of Status Display Mode

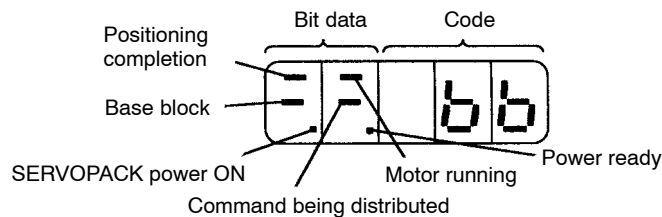





Bit Data Display Contents

Bit Data	Display
SERVOPACK Power ON	Lit when SERVOPACK input power ON. Not lit when input power OFF.
Base Block	Lit during base block. Not lit at servo ON.

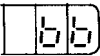
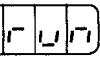
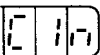
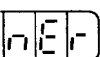
Bit Data	Display
Positioning Completion	Lit when the error between the position command and the actual motor position is smaller than the preset value. Not lit when the error is greater than the preset value. Preset value: Set in Cn-1B (1 pulse is standard.)
Motor Running	Lit when the motor speed is greater than the preset value. Not lit when the error is smaller than the preset value. Preset value: Set in Cn-0B (20 min ⁻¹ is standard.)
Command Being Distributed	Lit when an operation command is output to the motor. Not lit when no operation command is output.
Power Ready	Lit when the main circuit power supply is normal. Not lit when the power supply is OFF or faulty.

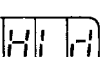
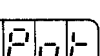
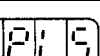
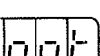
Display Codes

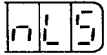
Code	Status
	Motor OFF
	Motor ON (when no command is being output)
	Positioning completed
	Positioning near
	Motor running
	Feed hold
	Positive overtravel
	Forward stored stroke limit exceeded
	Negative overtravel

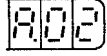
Code	Status
	Reverse stored stroke limit exceeded
  ...	Alarm status

5.1.7 Parameter Setting Mode

Functions can be selected and adjusted by setting parameters. Two types of parameters are available: Parameter settings and memory switches. The setting method differs for each.

Parameter settings enable the parameter data to be changed within a fixed range. The memory switches enable the required functions to be selected. A list of the parameters is given in *Appendix C*.

■ Changing Parameter Settings (Parameters Other Than Cn-01, -02, -26, -29, -32, -33, and -39)

Parameters can be adjusted using the following procedure. Check the ranges that can be set in the list of parameters in *Appendix C*.

The example below shows the procedure for changing the parameter Cn-15 from 100 to 85.

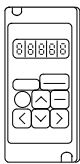

Hand-held Digital Operator

1. Press the DSPL/SET Key to select the parameter setting mode.

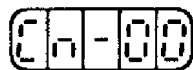

2. Select the parameter number to be set.

The set digit flashes and is changed when the Digit Up Key or Digit Down Key is pressed.

The value of the digit is changed when the Increment Key or Decrement Key is pressed.

3. Press the DATA/ENTER Key.

The current setting for the parameter selected in step 2 is displayed.



4. Set the required value.

The set digit flashes and is changed when the Digit Up Key or Digit Down Key is pressed.

The setting is changed when the Increment Key or Decrement Key is pressed.

Press the key until 00085 is displayed.

5. Press the DATA/ENTER Key.

The value flashes and is stored.



6. Press the DATA/ENTER Key once more.

The display reverts to the parameter number.

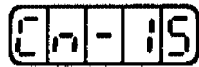

The setting of parameter Cn-15 has been successfully changed from 100 to 85.

To change the setting again, repeat steps 2 to 6.

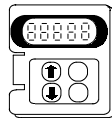

Mounted Digital Operator

1. Press the MODE/SET Key to select the setting mode.



2. Press the UP Key or DOWN Key to select the parameter number to be set.
3. Press the DATA Key.

The current setting for the parameter selected in step 2 is displayed.



4. Press the UP Key or DOWN Key to change to the required setting of 00085.
Continue pressing the key to change quickly to the next display.
5. Press the DATA Key.

The setting flashes and is stored.



6. Press the DATA Key once more.

The display reverts to the parameter number.

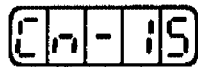

The setting of parameter Cn-15 has been successfully changed from 100 to 85.

To change the setting again, repeat steps 2 to 6.

■ **Changing Memory Switch Settings (Parameters Other Than Cn-01, -02, -26, -29, -32, -33, and -39)**

Functions can be selected by setting the memory switch bits to 0 or 1.

The example below shows the procedure for turning ON bit 4 of the memory switch in parameter Cn-01.

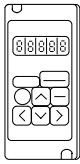

Hand-held Digital Operator

1. Press the DSPL/SET Key to select the setting mode.

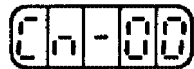

2. Select the parameter number to be set.

The set digit flashes and is changed when the Digit Up Key or Digit Down Key is pressed.

The value of the digit is changed when the Increment Key or Decrement Key is pressed.

3. Press the DATA/ENTER Key.

The current settings for the memory switch selected in step 2 are displayed.

Memory switch settings Bit number to be set

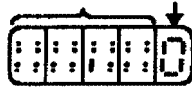

4. Press the Digit Up Key or Digit Down Key to select the bit number to be set.

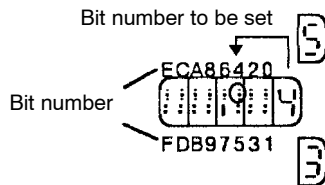

5. Press the Increment Key or Decrement Key to set the memory switch bit to 0 or 1.

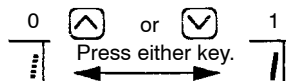

To change the setting again, repeat steps 4 and 5.

6. Press the DATA/ENTER Key.

The stored setting flashes and is stored.

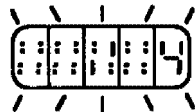

◆ **Setting Bits to 0 and 1**

Memory switches use 16 bits (0 to 9 and A to F), not numbers, to select functions. Select functions by turning these bits ON (set to 1) or OFF (set to 0).

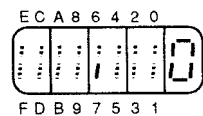

- ⋮ Set to 0.
- | Set to 1.

- Press the DATA/ENTER Key once more.

The display reverts to the parameter number.



Bit 4 of the memory switch of parameter Cn-01 has been successfully set to 1.

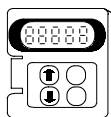

Mounted Digital Operator

- Press the MODE/SET Key to select the setting mode.

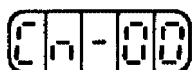

- Press the UP Key or DOWN Key to select the parameter number to be set.
- Press the DATA Key.

The current settings for the memory switches selected are displayed.

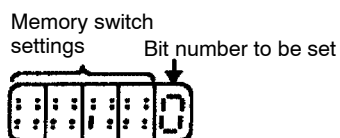

- Press the UP Key or DOWN Key to select the bit number to be set.

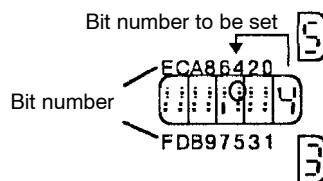

- Press the MODE/SET Key.

The memory switch setting for the bit number is set to 0 or 1.

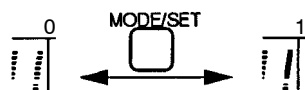

To change the setting, repeat steps 4 and 5.

- Press the DATA Key.

The setting flashes and is stored.

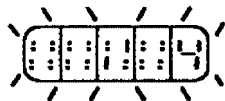

- Press the DATA Key once more.

The display reverts to the parameter number.



Bit 4 of the memory switch of parameter Cn-01 has been successfully set to 1.

5.1.8 Position Table Setting Mode

The position table setting mode enables command positions in the position table to be added or changed.

■ Using the Position Table Setting Mode

Hand-held Digital Operator

1. Press the DSPL/SET Key to select the position table setting mode.



Indicates the position table setting mode. Number in position table

2. Press the Increment Key or Decrement Key to select the number in the position table to be added or changed.
3. Press the DATA/ENTER Key.

The setting for the number in the position table selected in step 2 is displayed.

4. Press the Increment Key, Decrement Key, Digit Up Key, or Digit Down Key to add or change settings.

If the Digit Up Key is pressed when the leftmost digit of the lower digits is flashing, or the Digit Down Key is pressed when the rightmost digit of the lower digits is flashing, the higher digits will be displayed.

If the Digit Up Key is pressed when the leftmost digit of the higher digits is flashing, or the Digit Down Key is pressed when the rightmost digit of the higher digits is flashing, the lower digits will be displayed.

The leftmost higher digit is a sign digit, and when it flashes, the sign (plus or minus) can be set by pressing the Increment Key or Decrement Key.



Setting (lower 4 digits)



Setting (higher 4 digits)

5. Press the DSPL/SET Key or the DATA/ENTER Key to store the setting.
6. Press the DATA/ENTER Key once more.

The display reverts to the number in the position table.



To change the setting again, repeat steps 1 to 6.

Mounted Digital Operator

1. Press the MODE/SET Key to select the position table setting mode.



Indicates the position Number in position table setting mode.

2. Press the UP Key or DOWN Key to select the number in the position table to be added or changed.
3. Press the DATA Key.

The setting for the number in the position table selected in step 2 is displayed.

4. Press the MODE/SET Key to select the digits to be set.

Pressing the UP Key or DOWN Key increases or reduces the values of the set digits. Make sure these match the required set values.

If the MODE/SET Key is pressed when the rightmost digit of the lower digits is flashing, the higher digits will be displayed.

If the MODE/SET Key is pressed when the rightmost digit of the higher digits is flashing, the lower digits will be displayed.

The leftmost higher digit is a sign digit, and when it flashes, the sign (plus or minus) can be set by pressing the UP Key or DOWN Key.



Setting (lower 4 digits)



Setting (higher 4 digits)

5. Press the DATA Key to store the setting.
6. Press the DATA Key once more.

The display reverts to the number in the position table.



To change the setting again, repeat steps 1 to 6.

5.1.9 Speed Table Setting Mode

The speed table setting mode enables command speeds in the speed table to be added or changed.

■ Using the Speed Table Setting Mode

Hand-held Digital Operator

1. Press the DSPL/SET Key to select the speed table setting mode.



Indicates the speed table setting mode. Number in speed table

2. Press the Increment Key or Decrement Key to select the number in the speed table to be added or changed.
3. Press the DATA/ENTER Key.

The setting for the number in the speed table selected in step 2 is displayed.

4. Press the Increment Key, Decrement Key, Digit Up Key, or Digit Down Key to add or change the settings.

If the Digit Up Key is pressed when the leftmost digit of the lower digits is flashing, or the Digit Down Key is pressed when the rightmost digit of the lower digits is flashing, the higher digits will be displayed.

If the Digit Up Key is pressed when the leftmost digit of the higher digits is flashing, or the Digit Down Key is pressed when the rightmost digit of the higher digits is flashing, the lower digits will be displayed.



Setting (lower 4 digits)



Setting (higher 2 digits)

5. Press the DSPL/SET Key or the DATA/ENTER Key to store the setting.
6. Press the DATA/ENTER Key once more.

The display reverts to the number in the speed table.



To change the setting again, repeat steps 1 to 6 as required.

Mounted Digital Operator

1. Press the MODE/SET Key to select the speed table setting mode.



Indicates the speed table setting mode. Number in speed table

2. Press the UP Key or DOWN Key to select the number in the speed table to be added or changed.
3. Press the DATA Key.

The setting for the number in the speed table selected in step 2 is displayed.

4. Press the MODE/SET Key to select the digits to be set.

Pressing the UP Key or DOWN Key increases or reduces the values of the set digits. Make sure these match the required set values.

If the MODE/SET Key is pressed when the rightmost digit of the lower digits is flashing, the higher digits will be displayed.

If the MODE/SET Key is pressed when the rightmost digit of the higher digits is flashing, the lower digits will be displayed.



Setting (lower 4 digits)



Setting (higher 2 digits)

5. Press the DATA Key to store the setting.
6. Press the DATA Key once more.

The display reverts to the number in the speed table.



To change the setting again, repeat steps 1 to 6.

5.1.10 Boundary Table Setting Mode

The boundary table setting mode enables boundary positions in the boundary table to be added or changed.

■ Using the Boundary Table Setting Mode

Hand-held Digital Operator

1. Press the DSPL/SET Key to select the boundary table setting mode.



Indicates the boundary table setting mode. Number in boundary table

2. Press the Increment Key or Decrement Key to select the number in the boundary table to be added or changed.
3. Press the DATA/ENTER Key.

The setting for the number in the boundary table selected in step 2 is displayed.

4. Press the Increment Key, Decrement Key, Digit Up Key, or Digit Down Key to add or change the setting.

If the Digit Up Key is pressed when the leftmost digit of the lower digits is flashing, or the Digit Down Key is pressed when the rightmost digit of the lower digits is flashing, the higher digits will be displayed.

If the Digit Up Key is pressed when the leftmost digit of the higher digits is flashing, or the Digit Down Key is pressed when the rightmost digit of the higher digits is flashing, the lower digits will be displayed.

The leftmost higher digit is a sign digit, and when it flashes, the sign (plus or minus) can be set by pressing the Increment Key or Decrement Key.



Setting (lower 4 digits)



Setting (higher 4 digits)

5. Press the DSPL/SET Key or the DATA/ENTER Key to store the setting.
6. Press the DATA/ENTER Key once more.

The display reverts to the number in the boundary table.



To change the setting again, repeat steps 1 to 6.

Mounted Digital Operator

1. Press the MODE/SET Key to select the boundary table setting mode.



Indicates the boundary table setting mode. Number in boundary table

2. Press the UP Key or DOWN Key to select the number in the boundary table to be added or changed.

3. Press the DATA Key.

The setting for the number in the boundary table selected in step 2 is displayed.

4. Press the MODE/SET Key to select the digits to be set.

Pressing the UP Key or DOWN Key increases or reduces the values of the set digits. Make sure these match the required set values.

If the MODE/SET Key is pressed when the rightmost digit of the lower digits is flashing, the higher digits will be displayed.

If the MODE/SET Key is pressed when the rightmost digit of the higher digits is flashing, the lower digits will be displayed.

The leftmost higher digit is a sign digit, and when it flashes, the sign (plus or minus) can be set by pressing the UP Key or DOWN Key.



Setting (lower 4 digits)



Setting (higher 4 digits)

5. Press the DATA Key to store the setting.
6. Press the DATA Key once more.

The display reverts to the number in the boundary table.



To change the setting again, repeat steps 1 to 6.

5.1.11 Monitor Mode

The monitor mode enables the command data entered in the SERVOPACK, the I/O signal status, and the SERVOPACK internal status to be monitored.

The monitor mode can also be changed while the motor is running.

■ Using the Monitor Mode

The example below shows the procedure for displaying the data for monitor number Un-00.

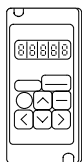

Hand-held Digital Operator

1. Press the DSPL/SET Key to select the monitor mode.

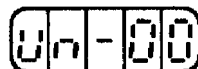

2. Press the Increment Key or Decrement Key to select the monitor number to be displayed.
3. Press the DATA/ENTER Key.

The value for the monitor number selected in step 2 is displayed.

Data

4. Press the DATA/ENTER Key once more.

The display reverts to the monitor number.

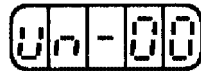

The data for monitor number Un-00 has been successfully displayed.

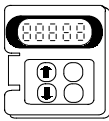

Mounted Digital Operator

1. Press the MODE/SET Key to select the monitor mode.



2. Press the UP Key or DOWN Key to select the monitor number to be displayed.
3. Press the DATA Key.

The value for the monitor number selected in step 2 is displayed.

Data

4. Press the DATA Key once more.

The display reverts to the monitor number.

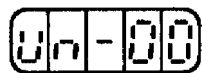

The data for monitor number Un-00 has been successfully displayed.

■ Monitor Mode Displays

The information displayed in the monitor mode is shown below.

Table 5.1 Monitor Displays

Monitor Number	Display Contents
<i>Un-00</i>	Actual motor speed: min^{-1}
<i>Un-01</i>	Target motor speed \times 1000 command units/min.
<i>Un-02</i>	Internal torque command % (with respect to rated torque)
<i>Un-03</i>	Number of pulses from phase-U edge (PG pulses \times 4)
<i>Un-04</i>	Motor electrical angle: degrees
<i>Un-05</i>	Internal status bit display 1 (discussed later)
<i>Un-06</i>	Internal status bit display 2 (discussed later)
<i>Un-07</i>	Input command pulse speed \times 1000 command units/min.
<i>Un-08</i>	Position error amount Units: \times 1 command unit (Cn-02 bit E = 0) \times 100 command units (Cn-02 bit E = 1)
<i>Un-09</i>	Command pulse counter value Units: Command units Displays a value between 0 and 65535.
<i>Un-0A</i>	Internal status bit display 3 (discussed later)
<i>Un-0B</i>	Internal status bit display 4 (discussed later)
<i>Un-0C</i>	Internal status bit display 5 (discussed later)
<i>Un-0d</i>	Digital switch (position data) set value
<i>Un-0E</i>	Digital switch (speed data) set value
<i>Un-0F</i>	Current position (command unit)

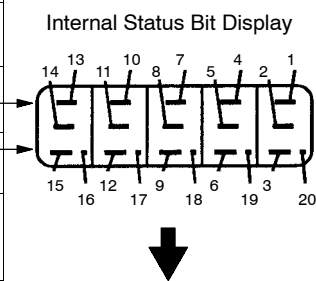

Table 5.2 Bit Displays

Monitor Number	Bit Number	Display Contents
Un-05	1	Lit with servo alarm
	2	Lit when dynamic brake ON
	3	Lit in reverse rotation mode (Cn-02 bit 0 = 1)
	4	Lit during motor rotation
	5	Lit at positioning completion
	6	Not lit during P control by mode switch or P-CON contact
	7	Lit during forward current limit
	8	Lit during reverse current limit
	9	Lit during motor power ON
	10	Lit when encoder phase A input = Low level
	11	Lit when encoder phase B input = Low level
	12	Lit when encoder phase C input = Low level
	13	Lit when encoder phase U input = Low level*
	14	Lit when encoder phase V input = Low level*
	15	Lit when encoder phase W input = Low level*
	16	Lit when /S-ON contact input = Low level
	17	Lit when /P-CON contact input = Low level
	18	Lit when P-OT contact input = High level
	19	Lit when N-OT contact input = High level
	20	None (always OFF)

* Incremental encoder only.

Monitor Number	Bit Number	Display Contents
Un-06	1	Lit when command pulse or line PG phase A input = High level*
	2	Lit when command pulse or line PG phase B input = High level*
	3	Lit when line PG phase C input = Low level
	4	Lit during current limit
	5	Lit during brake release
	6	Lit during overload warning
	7	Lit while main circuit power ON
	8	Lit during servo ready
	9 to 20	None (always OFF)
Un-0A	1	Lit when /ZRN (6CN-13) input = Low level
	2	Lit when /MAN (6CN-14) input = Low level
	3	Lit when /PULS (6CN-15) input = Low level
	4	Lit when /MCW (6CN-16) input = Low level
	5	Lit when /MCCW (6CN-17) input = Low level
	6	Lit when /RST (6CN-18) input = Low level
	7	Lit when /SP2ND (6CN-19) input = Low level
	8	Lit when /SP3RD (6CN-20) input = Low level
	9	Lit when /LPG (6CN-21) input = Low level
	10	Lit when /AST (6CN-22) input = Low level
	11	Lit when /ALMRST (6CN-23) input = Low level
	12	Lit when /STOP (6CN-24) input = Low level
	13 to 20	None (always OFF)

* Lit at low level when bit D of parameter Cn-02 is set to 1.

Monitor Number	Bit Number	Display Contents
Un-0B	1	Lit when /CD0 (6CN-33) input = Low level
	2	Lit when /CD1 (6CN-34) input = Low level
	3	Lit when /CD2 (6CN-35) input = Low level
	4	Lit when /CD3 (6CN-36) input = Low level
	5	Lit when /CD4 (6CN-37) input = Low level
	6	Lit when /CD5 (6CN-38) input = Low level
	7	Lit when /CD6 (6CN-39) input = Low level
	8	Lit when /CD7 (6CN-40) input = Low level
	9	Lit when /CD8 (6CN-41) input = Low level
	10	Lit when /CD9 (6CN-42) input = Low level
	11	Lit when /CD10 (6CN-43) input = Low level
	12	Lit when /CD11 (6CN-44) input = Low level
	13	Lit when /DR0 (6CN-45) input = Low level
	14	Lit when /DR1 (6CN-46) input = Low level
	15	Lit when /PS0 (6CN-47) input = Low level
	16	Lit when /PS1 (6CN-48) input = Low level
	17 to 20	None (always OFF)

Monitor Number	Bit Number	Display Contents
Un-0C	1	Lit when /AUT-LT (6CN-2) output = Low level
	2	Lit when /MAN-LT (6CN-3) output = Low level
	3	Lit when /POS1 (6CN-4) output = Low level
	4	Lit when /POS2 (6CN-5) output = Low level
	5	Lit when /AL0 (6CN-6) output = Low level
	6	Lit when /AL1 (6CN-7) output = Low level
	7	Lit when /AL2 (6CN-8) output = Low level
	8	Lit when /AL3 (6CN-9) output = Low level
	9	Lit when /ERR (6CN-27) output = Low level
	10	Lit when /P0 (6CN-28) output = Low level
	11	Lit when /P1 (6CN-29) output = Low level
	12	Lit when /P2 (6CN-30) output = Low level
	13	Lit when /P3 (6CN-31) output = Low level
	14	Lit when /P4 (6CN-32) output = Low level
	15 to 20	None (always OFF)

5.2 Practical Operation

This section describes how to use the Digital Operator to operate and adjust the motor. Read *5.1 Basic Operation* first.

5.2.1 Operation in Alarm Trace-back Mode

The alarm trace-back mode can display up to 10 previous alarms. It is useful for checking which alarms occurred, and when.

The alarm trace-back data is not cleared when the alarm is reset or when the SERVOPACK power is turned OFF. However, this does not affect operation.

The data can be cleared using the special mode, clearing of alarm trace-back mode. Refer to *5.2.4 Clearing Alarm Trace-back Data*.

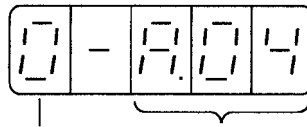

Alarm Sequence Number
The higher the number,
the older the alarm

Alarm Code
See the *Table 5.3 Alarm
Display Contents*.

■ Checking Alarms

Use the following procedure to check previous alarms.

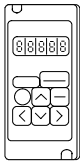

Hand-held Digital Operator

1. Press the DSPL/SET Key to select the alarm trace-back mode.

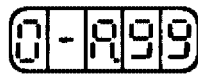

Alarm trace-back mode

2. Press the Increment Key or Decrement Key to scroll the sequence numbers up and down.
Previous alarm information is displayed.
The higher the leftmost digit, the older the alarm data.

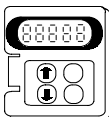

Mounted Digital Operator

1. Press the MODE/SET Key to select the alarm trace-back mode.

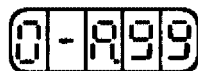

Alarm trace-back mode

2. Press the UP Key or DOWN Key to scroll the alarm sequence numbers up and down.
Previous alarm information is displayed.
The higher the leftmost digit, the older the alarm data.

■ Alarm Display Contents

The table below lists the alarms displayed in the alarm trace-back mode.
Refer to 7.2 *Troubleshooting*.

Table 5.3 Alarm Display Contents

Display (Trace-back Data)	Description
R.00	Absolute data error
R.02	EEPROM sum check error
R.04	Parameter setting alarm
R.05	SRAM sum check error
R.06	Back-up data sum check error
R.10	Overcurrent
R.30	Regenerative alarm
R.40	Main circuit voltage alarm
R.51	Overspeed
R.71	Overload (Instantaneous)
R.72	Overload (Continuous)
R.7A	Heat sink overheated
R.80	Encoder machine zero point alarm
R.81	Absolute encoder back-up alarm
R.82	Absolute encoder checksum alarm
R.83	Absolute encoder battery alarm SERVOPACK battery voltage drop alarm
R.84	Absolute encoder data alarm

Display (Trace-back Data)	Description
A85	Absolute encoder overspeed alarm
A60	Hardware alarm
A62	CPU alarm 1
A63	CPU alarm 2
AL1	Servo overrun alarm (This function prevents (minimizes) overrun.)
AL2	Encoder output phase alarm
AL3	Encoder phase A and B disconnection
AL4	Encoder phase C disconnection
AJ0	Position error pulse overflow
AF1	Power line open phase detected
AF3	Power failure alarm detected (detected when power turned ON again during power holding time)
A99	Not an alarm. Indicates normal status. Displayed when the alarm is reset or when the power is turned ON.

The following are operator-related alarms which are not recorded by alarm trace-back.

CPFD0	Digital Operator communications error 1
CPFD1	Digital Operator communications error 2

5.2.2 Operation Using the Digital Operator

Operation from the Digital Operator allows the SERVOPACK to run the motor. This allows rapid checking of motor rotating direction and setting of the motor speed during machine set-up and testing, without the trouble of connecting a host controller.

When the motor is operated by the Digital Operator, the motor speed can be changed with a parameter. The conditions are as follows:

Parameter: Cn-22

Unit: min^{-1}

Factory setting: 300

Refer to 5.1.7 *Parameter Setting Mode* for the method of setting the motor speed.

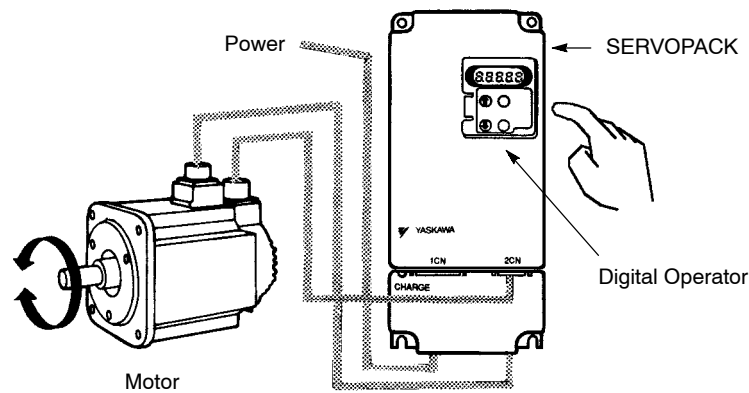

Use the following procedure to operate the motor from the Digital Operator.

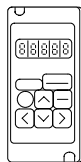

Hand-held Digital Operator

1. Press the DSPL/SET Key to select the setting mode.

Setting Mode

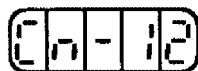

2. Select parameter Cn-00.

Cn-00 is selected when the power is turned ON.

Press the Digit Up Key or Digit Down Key to select the digits to be set.
Press the Increment Key or Decrement Key to change the value.

3. Press the DATA/ENTER Key.

The current setting for parameter Cn-00 is displayed.

Data

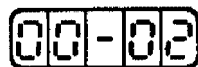

4. Press the Increment Key or Decrement Key to change the setting to 00.

00-00 is set when the power is turned ON.

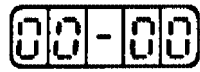

5. Press the DSPL/SET Key.

Enter the operation mode from the Digital Operator. Operation is now possible from the Digital Operator.



6. Press the SVON Key to set the servo ON status (motor turned ON).



7. Press the Increment Key or Decrement Key.

Pressing the motor rotates while the Key is pressed.



Forward rotation of motor



Reverse rotation of motor

8. Press the DSPL/SET Key.

The display reverts to 00-00. This sets the servo OFF status (motor turned OFF). The SVON Key also sets the servo to OFF.



9. Press the DATA/ENTER Key.

The display reverts to the setting mode.

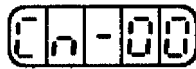

This ends the operation mode from the Digital Operator.

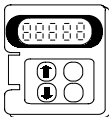

Mounted Digital Operator

1. Press the MODE/SET Key to select the setting mode.

Setting Mode

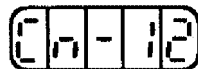

2. Press the UP Key or DOWN Key to select parameter Cn-00.

Cn-00 is selected when the power is turned ON.

3. Press the DATA Key.

The current setting for parameter Cn-00 is displayed.

Data



4. Press the UP Key or DOWN Key to change the setting to 00.

00-00 is set when the power is turned ON.



5. Press the MODE/SET Key.

Enter the operation mode from the Digital Operator. Operation is now possible from the Digital Operator.



6. Press the DATA Key.

This sets the servo ON status (motor turned ON).



7. Press the UP Key or DOWN Key.

The motor rotates while the Key is pressed.



Forward rotation
of motor



Reverse rotation
of motor

8. Press the MODE/SET Key.

The display reverts to 00-00. This sets the servo OFF status (motor turned OFF). Pressing the DATA Key also sets the servo to OFF.



9. Press the DATA Key.

The display reverts to the setting mode.



This ends the operation mode from the Digital Operator.

5.2.3 Autotuning

The SERVOPACK contains a built-in autotuning function to automatically measure the machine characteristics (machine configuration and machine rigidity) and set the parameters.

Autotuning allows even totally inexperienced people to easily complete the tuning.

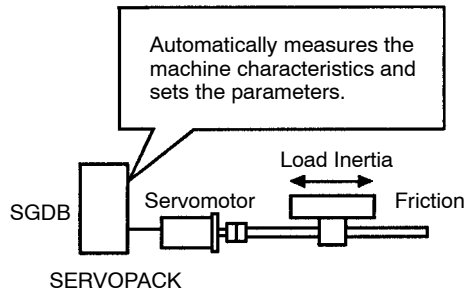

■ Precautions on Autotuning

To perform autotuning, it is necessary to set the speed, machine rigidity, and input signals. In addition, the SERVOPACK and motor operations differ from normal operations. Before performing autotuning, check the following items:

Handling the Stored Stroke Limit

During tuning, the stored stroke limit does not function normally.

The stored stroke limit may not always stop the load at the set position. (P-OT and N-OT function in the same way as with normal operations.)

Speed Setting During Tuning

The motor speed during tuning is set by parameter Cn-22. The motor speed changes according to the gear ratio, set Cn-22 so the speed is 500 min^{-1} .

If the set value is too low, it may not be possible to perform autotuning.

The motor does not run continuously, but intermittently, while the Increment Key or Decrement Key (UP Key or DOWN Key) is held down.

Machine Rigidity Selection



Select the machine rigidity as described below. If the actual rigidity is unknown, select medium rigidity.

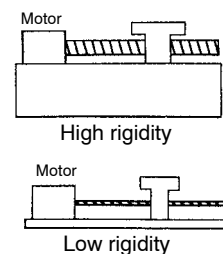

◆ Machine Rigidity

The machine rigidity is one of the machine characteristics related to servo control. Set the servo to high response for a machine, such as a machine tool, with high rigidity, and to low response for a machine, such as a robot, with low rigidity.



-  High Rigidity
-  Medium Rigidity
-  Low Rigidity

If the Machine Resonates

When the servo is turned ON with the SVON Key (or DATA Key), or when the motor is operated by pressing the Increment Key or Decrement Key (UP Key or DOWN Key), machine resonance indicates an inappropriate machine rigidity selection. Re-tune the machine.

1. Press the DSPL/SET Key (or MODE/SET Key) to cancel the tuning.
2. Press the DSPL/SET Key (or MODE/SET Key) once more.
This sets the machine rigidity selection mode. Decrement the machine rigidity number by one.

If Autotuning Does Not End

Failure of autotuning to end , is caused by an inappropriate machine rigidity setting. Follow the procedure below to correct the machine rigidity selection, and perform autotuning once more.

1. Press the DSPL/SET Key (or MODE/SET Key) to cancel the tuning.
2. Press the DSPL/SET Key (or MODE/SET Key) once more.
This sets the machine rigidity selection mode. Increment the machine rigidity number by one.

Autotuning may not end for machines with large play or extremely low rigidity. In these cases, use conventional manual tuning referring to *Appendix A*.

Input Signals

- The P-OT signal and N-OT signal are enabled in autotuning mode.
If these signals are not used, set bits 2 and 3 of parameter Cn-01 to 1.
- Autotuning is not possible during overtravel (P-OT or N-OT signal OFF).

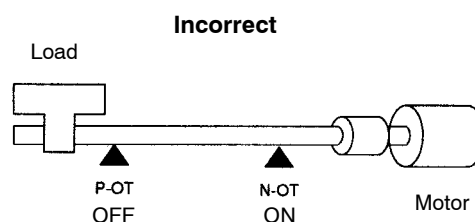

- Perform autotuning when no overtravel has occurred (both P-OT and N-OT signal ON).

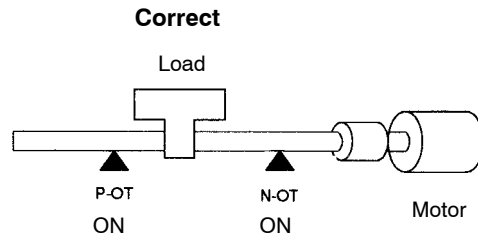

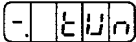
- When performing autotuning, set the P-CON signal to OFF status.
- When using the mode switching function, perform autotuning after performing one of the following operations:
 - Not using mode switching.
 - Setting a higher mode switching level.
- If the /S-ON signal is used to set the servo ON status, turn ON the /S-ON signal after  is displayed.
- After checking that the machine can be operated, attach the motor to the machine and perform autotuning.
- Check that the P-CON signal is in OFF status (PI control) before performing autotuning.
- To perform autotuning, set the speed control mode to PI control.

When the mode switching function is used, P control automatically takes over above the operating level (mode switch PI control → P control switch level), even if the P-CON signal is set to OFF. When the mode switching function is used, set the following settings before performing autotuning:

- Set bit B of parameter Cn-01 to 1 so that mode switching is not used.
- Set a higher operating level (mode switch PI control → P control switch level) so that P control does not take over.

Use the settings shown below, according to the operating level. Select bit C or D of Cn-01 as the operating level.

Operating Level (Bit C or D of Cn-01)	Parameter Setting
Torque command (0, 0)	Set Cn-0C to the maximum torque.
Speed command (0, 1)	Make Cn-0C greater than the set value of Cn-22.
Acceleration (1, 0)	Set a maximum value of 3000 for Cn-0C.
Error pulse (1, 1)	Set a maximum value of 10000 for Cn-0C.

■ Parameters Automatically Settable with Autotuning

The three parameters shown below can be set with autotuning.

Cn-04	Speed loop gain
Cn-05	Speed loop integration time constant
Cn-1A	Position loop gain

Once autotuning has been completed, the autotuning procedure can be omitted for subsequent machines, if the machine specifications remain unchanged.

It is sufficient to directly set the parameters for subsequent machines.

The machine rigidity can be selected from one of seven levels.

■ Using Autotuning

Follow the procedure below to perform autotuning.

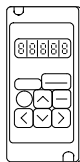

Hand-held Digital Operator

1. Press the DSPL/SET Key to select the setting mode.

Setting Mode

2. Select parameter Cn-00.

Cn-00 is selected when the power is turned ON.

Press the Digit Up Key or Digit Down Key to select the digits to be set.

Press the Increment Key or Decrement Key to change the value.



3. Press the DATA/ENTER Key.

The current setting for the parameter is displayed.

Data

4. Press the Increment Key or Decrement Key to change the setting to 05 as shown below.



5. Press the DSPL/SET Key.

The machine rigidity setting is displayed.



Machine Rigidity Display

6. Press the Increment Key or Decrement Key to select the machine rigidity.
If the machine rigidity is unknown, select medium rigidity (C-003 to C-005).
7. Press the DSPL/SET Key to select the autotuning mode.



8. Press the SVON Key to turn the servo ON.



9. Press the Increment Key or Decrement Key.

The motor rotates while the Key is pressed.

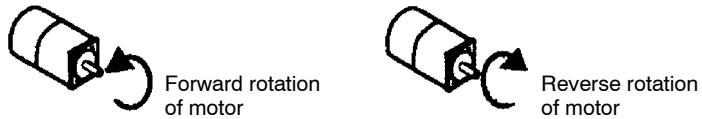

If “= . End” appears, tuning has been completed.



At this point, the servo automatically turns OFF.

If the servo is turned ON or OFF by an external contact signal, turn OFF this contact signal.

10. Release the Increment Key or Decrement Key.

The display changes to 00-05.

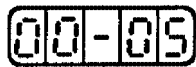

11. Press the DATA/ENTER Key.

The display reverts to the setting mode.

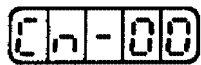

Setting Mode Display

The autotuning has now been completed.

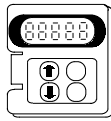

Mounted Digital Operator

1. Press the MODE/SET Key to select the setting mode.

Setting Mode



2. Press the UP Key or DOWN Key to select parameter Cn-00. Cn-00 is selected when the power is turned ON.
3. Press the DATA Key.

The current setting for the parameter is displayed.

Data



4. Press the UP Key or DOWN Key to change the setting to 05.

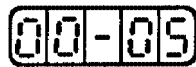

5. Press the MODE/SET Key.

The machine rigidity setting is displayed.



Machine Rigidity Display

6. Press the UP Key or DOWN Key to select the machine rigidity (C-001 to C-007).
7. Press the MODE/SET Key to select the autotuning mode.



Autotuning Mode

8. Press the DATA Key to select the servo ON status.



9. Press the UP Key or DOWN Key.

The motor rotates while the Key is pressed.



Forward rotation
of motor



Reverse rotation
of motor

If the display below appears, tuning has been completed.



Autotuning Complete

At this point, the servo automatically turns OFF.

If the servo is turned ON or OFF by an external contact signal, turn OFF this contact signal.

10. Release the UP Key or DOWN Key.

The display changes to 00-05.

11. Press the DATA Key.

The display reverts to the setting mode.

Setting Mode Display

The autotuning has now been completed.

5.2.4 Clearing Alarm Trace-back Data

This procedure clears the alarm history, which stores the alarms occurring in the SERVOPACK. When this procedure is performed, each alarm in the alarm history is set to A99, which is not an alarm code. Refer to 5.2.1 *Operation in Alarm Trace-back Mode* for details.

Follow the procedure below to clear the alarm trace-back data.

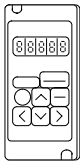

Hand-held Digital Operator

1. Press the DSPL/SET Key to select the setting mode.

Setting Mode

2. Select parameter Cn-00.

Cn-00 is selected when the power is turned ON.

Press the Digit Up Key or Digit Down Key to select the digits to be set.

Press the Increment Key or Decrement Key to change the value.

3. Press the DATA/ENTER Key.

The current setting for the parameter is displayed.

Data

4. Press the Increment Key or Decrement Key to change the setting to 02.

5. Press the DSPL/SET Key.

The alarm trace-back data is cleared.

6. Press the DATA/ENTER Key.

The display reverts to the parameter number.

Parameter Number

Cn-00

The alarm trace-back data clearing operation has now been completed.

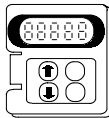

Mounted Digital Operator

1. Press the MODE/SET Key to select the setting mode.

Setting Mode

Cn-12

2. Press the UP Key or DOWN Key to select parameter Cn-00.

Cn-00 is selected when the power is turned ON.

Cn-00

3. Press the DATA Key.

The current setting for the parameter is displayed.

Data

00-00

4. Press the UP Key or DOWN Key to change the setting to 02.

00-02

5. Press the MODE/SET Key.

The alarm trace-back data is cleared.

6. Press the DATA Key.

The display reverts to the parameter number.

Parameter Number

Cn-00

The alarm trace-back data clearing operation has now been completed.

5.2.5 Checking the SERVOPACK Specifications

This mode is used for maintaining the motor.

When Cn-00 is set to 00-04, this mode is used to check the SERVOPACK specifications.

Use the following procedure to check the SERVOPACK specifications.

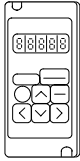

Hand-held Digital Operator

1. Set Cn-00 to 00-04.
2. Press the DSPL/SET Key.

The SERVOPACK capacity is displayed.

SERVOPACK Capacity Display

F.0005

Motor model
0: Σ Series

SERVOPACK Capacity	
02: 0.2 kW	32: 5.0 kW
05: 0.5 kW	3C: 6.0 kW
0A: 1.0 kW	4B: 7.5 kW
0F: 1.5 kW	6E: 11.0 kW
14: 2.0 kW	96: 15.0 kW
1E: 3.0 kW	

3. Press the DSPL/SET Key.

The special specification (Y specification) is displayed.

Special Specification
(Y Specification) Display

4001A (Hexadecimal notation)
(1) (2) (3) (4)

$$(1) \times 16^3 + (2) \times 16^2 + (3) \times 16 + (4) = \text{special specification (Y specification number)}$$

Checking of the SERVOPACK specifications has now been completed.

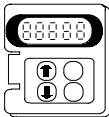

Mounted Digital Operator

1. Set Cn-00 to 00-04.
2. Press the MODE/SET Key.

The SERVOPACK capacity is displayed.

3. Press the MODE/SET Key.

The special specification (Y specification) is displayed.

Checking of the SERVOPACK specifications has now been completed.

5.2.6 Checking the Software Version

This mode is used for maintaining the SERVOPACK.

When Cn-00 is set to 00-06, this mode is used to check the software version.

Use the following procedure to check the software version.

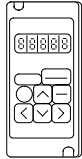

Hand-held Digital Operator

1. Set Cn-00 to 00-06.
2. Press the DSPL/SET Key.

The main CPU software version is displayed.

Main CPU Software Version Display

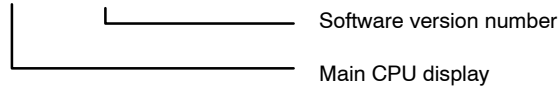

3. Press the DSPL/SET Key.

The servo CPU software version is displayed.

Servo CPU Software Version Display

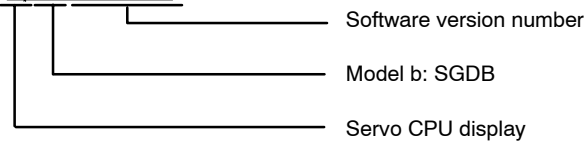

Checking of the software version has now been completed.

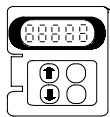

Mounted Digital Operator

1. Set Cn-00 to 00-06.
2. Press the MODE/SET Key.

The main CPU software version is displayed.

3. Press the MODE/SET Key.

The servo CPU software version is displayed.

Checking of the software version has now been completed.

5.2.7 Adjusting the Current Detection Offset Manually

Current detection offset manual adjustment is performed at Yaskawa before shipping. Basically, the customer need not perform this adjustment. Perform this adjustment only when highly accurate adjustment is required in combination with the motor used.

Run the motor at a speed of approximately 100 min^{-1} , and adjust the SERVOPACK until the torque monitor ripple is minimized. Adjust the phase-U and phase-V offsets alternately several times until these offsets are well balanced.

Use the follow procedure to perform current detection offset manual adjustment.

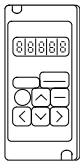

Hand-held Digital Operator

1. Press the DSPL/SET Key to select the setting mode.

Setting Mode

Cn-12

2. Select parameter Cn-00.

Cn-00 is selected when the power is turned ON.

Press the Digit Up Key or Digit Down Key to select the digits to be set.

Press the Increment Key or Decrement Key to change the value.

Cn-00

3. Press the DATA/ENTER Key.

The current setting for the parameter is displayed.

Data

00-02

4. Press the Increment Key or Decrement Key to change the setting to 08.

00-08

5. Press the DSPL/SET Key.

The display changes to the current detection offset manual adjustment mode. The amount of current detection offset is displayed.

A0000

6. Press the Digit Up or Digit Down Key.

The display switches between the phase U and phase V.

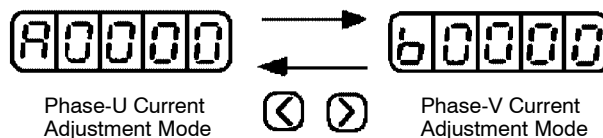

7. Press the Increment Key or Decrement Key to adjust the amount of offset.
8. Press the DSPL/SET Key.

The display reverts to the parameter number.

9. Press the DATA/ENTER Key.

The display reverts to the setting mode.

Setting Mode Display

The current detection offset manual adjustment has now been completed.

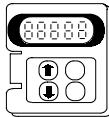

Mounted Digital Operator

1. Press the MODE/SET Key to select the setting mode.

Setting Mode

2. Press the UP Key or DOWN Key to select parameter Cn-00.

Cn-00 is selected when the power is turned ON.

3. Press the DATA Key.

The current setting for the parameter is displayed.

Data

4. Press the UP Key or DOWN Key to change the setting to 08.

5. Press the MODE/SET Key.

The display changes to the current detection offset manual adjustment mode. The amount of current detection offset is displayed.

6. Press the DATA Key. The display switches between the phase U and phase V.

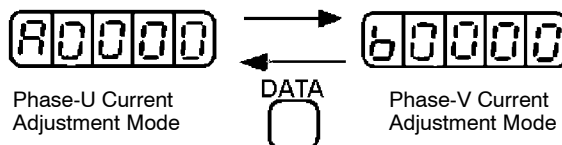

7. Press the UP Key or DOWN Key to adjust the amount of offset.
8. Press the MODE/SET Key.

The display reverts to the parameter setting.

00-08

9. Press the DATA Key.

The display reverts to the setting mode.

Setting Mode Display

Cn-00

The current detection offset manual adjustment has now been completed.

5.2.8 Setting the Machine Zero Point

When the motor is first connected to the SERVOPACK and the power is turned ON, or when the battery has been removed for more than four days without the SERVOPACK power being turned ON, perform the operation shown below after setting up the absolute encoder.

Before performing this operation, either use manual operation mode or pulse train operation mode, or rotate the motor externally and move to the machine zero point (coordinate \pm nnnnnnnn).

Use the following procedure to set the machine zero point.

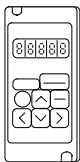

Hand-held Digital Operator

1. Press the DSPL/SET Key to select the setting mode.

Setting Mode

Cn-12

2. Select parameter Cn-00.

Cn-00 is selected when the power is turned ON.

Press the Digit Up Key or Digit Down Key to select the digits to be set.

Press the Increment Key or Decrement Key to change the value.

Cn-00

3. Press the DATA/ENTER Key.

The current setting for the parameter is displayed.

Data

00-02

- Press the Increment Key or Decrement Key to change the setting to 0A.

- Press the DSPL/SET Key.

The display changes to the machine zero point setting mode. The machine zero point to be set is displayed.

- Press the Digit Up Key or Digit Down Key to select the digits to be set.

If the digit that is currently flashing is at the end of the display area, it is possible to move from the lower digits to the higher digits, or from the higher digits to a lower digits by pressing the Digit Up Key or Digit Down Key in the direction away from this digit.

The leftmost higher digit is a sign digit, and when it flashes, the sign (plus or minus) can be set by pressing the Increment Key or Decrement Key.

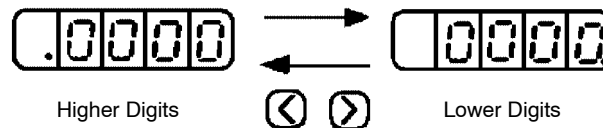

- Press the Increment Key or Decrement Key to set the machine zero point.

- Press the DSPL/SET Key.

The input value flashes.

- Press the DATA/ENTER Key.

The display reverts to the parameter setting.

- Press the DATA/ENTER Key.

The display reverts to the setting mode.

Setting Mode Display

The machine zero point setting has now been completed.

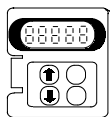

Mounted Digital Operator

- Press the MODE/SET Key to select the setting mode.

Setting Mode

2. Press the UP Key or DOWN Key to select parameter Cn-00.

Cn-00 is selected when the power is turned ON.

3. Press the DATA Key.

The current setting for the parameter is displayed.

Data

4. Press the UP Key or DOWN Key to change the setting to 0A.

5. Press the MODE/SET Key.

The display changes to the machine zero point setting mode. The machine zero point to be set is displayed.

6. Press the MODE/SET Key to select the digits to be set.

If the DOWN Key is pressed when the rightmost lower digit flashes, the higher digits are displayed.

If the DOWN Key is pressed when the rightmost higher digit flashes, the lower digits are displayed.

The leftmost higher digit is a sign digit, and when it flashes, a sign (plus or minus) can be set by pressing the Increment Key or Decrement Key.

7. Press the DOWN Key to select the digit, and press the UP Key to set the value for this digit.

8. Press the MODE/SET Key.

The display reverts to the parameter setting.

9. Press the DATA Key.

The display reverts to the setting mode.

Setting Mode Display

The machine zero point setting has now been completed.

5.2.9 Saving Backup Data

The SERVOPACK backup data consists of parameters, table data, and absolute encoder position data. Because the data and parameters are stored in the battery backup memory, they may be deleted due to battery consumption. If the following operation performed after setting the backup data, the backup data can be saved to nonvolatile memory.

Use the following procedure to save the backup data.

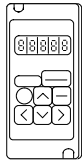

Hand-held Digital Operator

1. Press the DSPL/SET Key to select the setting mode.

Setting Mode

Cn-12

2. Select parameter Cn-00.

Cn-00 is selected when the power is turned ON.

Press the Digit Up Key or Digit Down Key to select the digits to be set.

Press the Increment Key or Decrement Key to change the value.

Cn-00

3. Press the DATA/ENTER Key.

The current setting for the parameter is displayed.

Data

00-00

4. Press the Increment Key or Decrement Key to change the setting to 0b.

00-0b

5. Press the DSPL/SET Key.

The display changes to the backup data save mode.

SAVE

6. Press the DSPL/SET Key.

When the backup data has been written to nonvolatile memory, “End” is displayed. Do not turn OFF the SERVOPACK control power until “End” is displayed. Also, if the DATA/ENTER Key is pressed in the parameter save mode, the data is not saved and the display reverts to the parameter setting.

End

7. Press the DATA/ENTER Key.

The display reverts to the parameter setting.

8. Press the DATA/ENTER Key.

The display reverts to the parameter number.

Parameter Number

The operation for saving the backup data has now been completed.

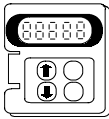

Mounted Digital Operator

1. Press the MODE/SET Key to select the setting mode.

Setting Mode

2. Press the UP Key or DOWN Key to select parameter Cn-00.

Cn-00 is selected when the power is turned ON.

3. Press the DATA Key.

The current setting for the parameter is displayed.

Data

4. Press the UP Key or DOWN Key to change the setting to 0b.

5. Press the MODE/SET Key.

The display changes to the backup data save mode.

6. Press the MODE/SET Key.

When the backup data has been written to nonvolatile memory, “End” is displayed. Do not turn OFF the SERVOPACK control power until “End” is displayed. Also, if the DATA Key is pressed in the parameter save mode, the data is not saved and the display reverts to the parameter number.

7. Press the DATA Key.

The display reverts to the parameter setting.

8. Press the DATA Key.

The display reverts to the parameter number.

Parameter Number

The operation for saving the backup data has now been completed.

5.2.10 Reading Backup Data

If the SERVOPACK backup data has been deleted, or the previously saved status need to be returned, performing this operation enables the backup data saved to nonvolatile memory to be read.

Use the following procedure to read the backup data.

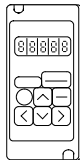

Hand-held Digital Operator

1. Press the DSPL/SET Key to select the setting mode.

Setting Mode

2. Select parameter Cn-00.

Cn-00 is selected when the power is turned ON.

Press the Digit Up Key or Digit Down Key to select the digits to be set.

Press the Increment Key or Decrement Key to change the value.

3. Press the DATA/ENTER Key.

The current setting for the parameter is displayed.

Data

4. Press the Increment Key or Decrement Key to change the setting to 0C.

5. Press the DSPL/SET Key.

The display changes to the backup data read mode.

A digital display showing the word "LOAD" in a segmented font, with each letter occupying one of the four display segments.

6. Press the DSPL/SET Key.

When the backup data has been read from nonvolatile memory, "End" is displayed. Do not turn OFF the SERVOPACK control power until "End" is displayed. Also, if the DATA/ENTER Key is pressed in the parameter read mode, the data is not read and the display reverts to the parameter setting.

A digital display showing the word "End" in a segmented font, with each letter occupying one of the four display segments.

7. Press the DATA/ENTER Key.

The display reverts to the parameter setting.

A digital display showing "00-00" in a segmented font, with the first two segments showing "00", a hyphen, and the last two segments showing "00".

8. Press the DATA/ENTER Key.

The display reverts to the parameter number.

Parameter Number

A digital display showing "Cn-00" in a segmented font, with the first segment showing "C", the second showing "n", a hyphen, and the last two segments showing "00".

The operation for reading the backup data has now been completed.

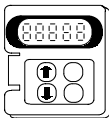

Mounted Digital Operator

1. Press the MODE/SET Key to select the setting mode.

Setting Mode

A digital display showing "Cn-12" in a segmented font, with the first segment showing "C", the second showing "n", a hyphen, and the last two segments showing "12".

2. Press the UP Key or DOWN Key to select parameter Cn-00.

Cn-00 is selected when the power is turned ON.

A digital display showing "Cn-00" in a segmented font, with the first segment showing "C", the second showing "n", a hyphen, and the last two segments showing "00".

3. Press the DATA Key.

The current setting for the parameter is displayed.

Data

A digital display showing "00-00" in a segmented font, with the first two segments showing "00", a hyphen, and the last two segments showing "00".

4. Press the UP Key or DOWN Key to change the setting to 0C.

A digital display showing "00-0C" in a segmented font, with the first two segments showing "00", a hyphen, and the last two segments showing "0C".

5. Press the MODE/SET Key.

The display changes to the backup data read mode.

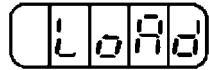

6. Press the MODE/SET Key.

When the backup data has been read from nonvolatile memory, “End” is displayed. Do not turn OFF the SERVOPACK control power until “End” is displayed. Also, if the DATA Key is pressed in the parameter read mode, the data is not read and the display reverts to the parameter setting.



7. Press the DATA Key.

The display reverts to the parameter setting.

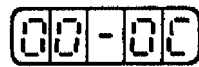

8. Press the DATA Key.

The display reverts to the parameter number.

Parameter Number



The operation for reading the backup data has now been completed.

5.2.11 Initializing Backup Data

This operation makes it possible to return the current backup data to the factory-set backup data.

Use the following procedure to initialize the backup data.

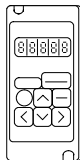

Hand-held Digital Operator

1. Press the DSPL/SET Key to select the setting mode.

Setting Mode



2. Select parameter Cn-00.

Cn-00 is selected when the power is turned ON.

Press the Digit Up Key or Digit Down Key to select the digits to be set.

Press the Increment Key or Decrement Key to change the value.

3. Press the DATA/ENTER Key.

The current setting for the parameter is displayed.

Data

4. Press the Increment Key or Decrement Key to change the setting to 0d.

5. Press the DSPL/SET Key.

The display changes to the backup data initialization mode.

6. Press the DSPL/SET Key.

When the backup data in the battery backup memory has been returned to the factory setting, “End” is displayed. Do not turn OFF the SERVOPACK control power until “End” is displayed. Also, if the DATA/ENTER Key is pressed in the battery backup data initialization mode, the data is not initialized and the display reverts to the parameter number.

7. Press the DATA/ENTER Key.

The display reverts to the parameter setting.

8. Press the DATA/ENTER Key.

The display reverts to the parameter number.

Parameter Number

The operation for initializing the backup data has now been completed.

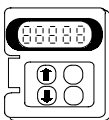

Mounted Digital Operator

1. Press the MODE/SET Key to select the setting mode.

Setting Mode

2. Press the UP Key or DOWN Key to select parameter Cn-00.

Cn-00 is selected when the power is turned ON.

3. Press the DATA Key.

The current setting for the parameter is displayed.

Data

 The LCD display shows the current parameter setting as '00-00'.

4. Press the UP Key or DOWN Key to change the setting to 0d.

The LCD display shows the parameter setting changed to '00-0d'.

5. Press the MODE/SET Key.

The display changes to the backup data initialization mode.

The LCD display shows 'Init' in the backup data initialization mode.

6. Press the MODE/SET Key.

When the backup data in the battery backup memory has been returned to the factory setting, “End” is displayed. Do not turn OFF the SERVOPACK control power until “End” is displayed. Also, if the DATA Key is pressed in the battery backup data initialization mode, the data is not initialized and the display reverts to the parameter setting.

The LCD display shows 'End'.

7. Press the DATA Key.

The display reverts to the parameter setting.

The LCD display shows the parameter setting '00-0d'.

8. Press the DATA Key.

The display reverts to the parameter number.

Parameter Number

The LCD display shows the parameter number 'Cn-00'.

The operation for initializing the backup data has now been completed.

6

Servo Selection and Data Sheets

This chapter describes how to select Σ -Series Servodrives and peripheral devices.

The section also presents the specifications and dimensional drawings required for selection and design.

Choose and carefully read the relevant sections of this chapter.

6.1	Selecting a Σ-Series Servo	6 -3
6.1.1	Selecting a Servomotor	6 -3
6.1.2	Selecting a SERVOPACK	6 -15
6.1.3	Selecting a Digital Operator	6 -17
6.2	Servomotor Ratings and Specifications	6 -19
6.2.1	Ratings and Specifications	6 -19
6.2.2	Mechanical Characteristics	6 -41
6.3	SERVOPACK Ratings and Specifications	6 -45
6.3.1	Combined Specifications	6 -45
6.3.2	Ratings and Specifications	6 -48
6.3.3	Overload Characteristics	6 -52
6.3.4	Starting Time and Stopping Time	6 -53
6.3.5	Load Inertia	6 -53
6.3.6	Overhanging Loads	6 -54
6.4	Σ-Series Dimensional Drawings	6 -55
6.4.1	Servomotor Dimensional Drawings	6 -55
6.4.2	SERVOPACK Dimensional Drawings	6 -138
6.4.3	Digital Operator Dimensional Drawings	6 -149
6.5	Selecting Peripheral Devices	6 -150
6.5.1	Selecting Peripheral Devices	6 -150
6.5.2	Order List	6 -165

6.6 Specifications and Dimensional Drawings of	
Peripheral Devices	6 -190
6.6.1 Cable Specifications and Peripheral Devices	6 -190
6.6.2 Motor Cables	6 -194
6.6.3 Connector	6 -195
6.6.4 Brake Power Supply	6 -216
6.6.5 Encoder Cables	6 -218
6.6.6 Back-up Battery	6 -229
6.6.7 1CN and 6CN Connectors	6 -230
6.6.8 3CN Connector	6 -232
6.6.9 Connector-Terminal Block Conversion Unit	6 -233
6.6.10 Cable with 1CN Connector and One End without Connector	6 -239
6.6.11 Cable with 6CN Connector and One End without Connector	6 -240
6.6.12 Circuit Breaker	6 -241
6.6.13 Noise Filter	6 -241
6.6.14 Magnetic Contactor	6 -243
6.6.15 Surge Suppressor	6 -245
6.6.16 Regenerative Resistor Unit	6 -246
6.6.17 External Position Indicator (Model MCIF-L8) ...	6 -247
6.6.18 Digital Switch Unit (MCIF-D□□)	6 -249
6.6.19 Contact Input Unit (MCIF-R86)	6 -252
6.6.20 Manual Pulse Generator (PRET-2C3T/100-M1) .	6 -255
6.6.21 Cables for Connecting Personal Computer and SERVOPACK	6 -256

6.1 Selecting a Σ -Series Servo

This section describes how to select the Σ -Series Servomotor, SERVOPACK, and Digital Operator.

6.1.1 Selecting a Servomotor

The method of selection differs according to the model of Servomotor. Numbers 1 to 6 in the following explanation correspond to 1 through 6 in the Flowchart for Servomotor Selection on following pages.

■ Selecting an SGMG, SGMS, or SGMD Servomotor

The following pages provide an explanation of Σ -Series Servomotor models and selection flowcharts.

Models

Each model of Σ-Series Servomotor can be identified by specifying an 8-digit alphanumeric code following “SGM□-”.

SGM□ - 03 A 2 A A □ □

- Σ-Series
- G: SGMG Servomotor
- S: SGMS Servomotor
- D: SGMD Servomotor

1. Rated output (motor capacity)

- 03: 0.3kW (0.40HP) 05: 0.45kW (0.60HP) 06: 0.6kW (0.80HP)
- 09: 0.85kW(1.14HP), 0.9kW(1.21HP) 10: 1.0kW (1.34HP)
- 12: 1.2kW (1.61HP) 13: 1.3kW (1.74HP) 15: 1.5kW (2.01HP)
- 20: 1.8kW (2.41HP), 2.0kW (2.68HP) 22: 2.2kW (2.95HP)
- 30: 2.9kW (3.89HP), 3.0kW (4.02HP) 32: 3.2kW (4.29HP)
- 40: 4.0kW (5.36HP) 44: 4.4kW (5.90HP) 50: 5.0kW (6.71HP)
- 55: 5.5kW (7.38HP) 60: 6.0kW (8.05HP) 75: 7.5kW (10.06HP)
- 1A: 11kW (14.75HP) 1E: 15kW(20HP)

2. Supply voltage

- A: 200V

3. Encoder specification

- 2: 8192 P/R incremental encoder
- 6: 4096 P/R incremental encoder
- W: 12-bit (1024 P/R) absolute encoder
- S: 15-bit (8192 P/R) absolute encoder

4. Rated speed

- A: SGMG (1500 min⁻¹)
SGMS (3000 min⁻¹)
SGMD (2000 min⁻¹)
- B: SGMG (1000 min⁻¹)

5. Shaft specification

- Blank: Standard (straight without key)
- A: Standard (straight without key, only when “options” and “lead specification” columns are not blank)
- B: Straight with key and one shaft-end tap
- C: Taper 1/10 with parallel key
- D: Taper 1/10 with Woodruff key (for G Series 05 and 09 only)

6. Options

- Blank: Standard
- 1: Standard (only when “lead specification” column is not blank)
- S: With oil seal
- B: With 90 VDC brake
- C: With 24 VDC brake
- F: With oil seal and 90 VDC brake
- G: With oil seal and 24 VDC brake

Lead specification

- Blank: Standard (connector)



Flowchart for Servomotor selection

	Selected motor model
Example	SGMG- 0 9 A 2 A B S □
Axis 1	SGM □ - □ □ □ □ □ □ □ □
Axis 2	SGM □ - □ □ □ □ □ □ □ □
• • •	• • • • Blank for standard specification

Flowchart for Servomotor Selection

The actual selection of the SGMG, SGMS or SGMD Servomotor is performed according to the following flowchart.

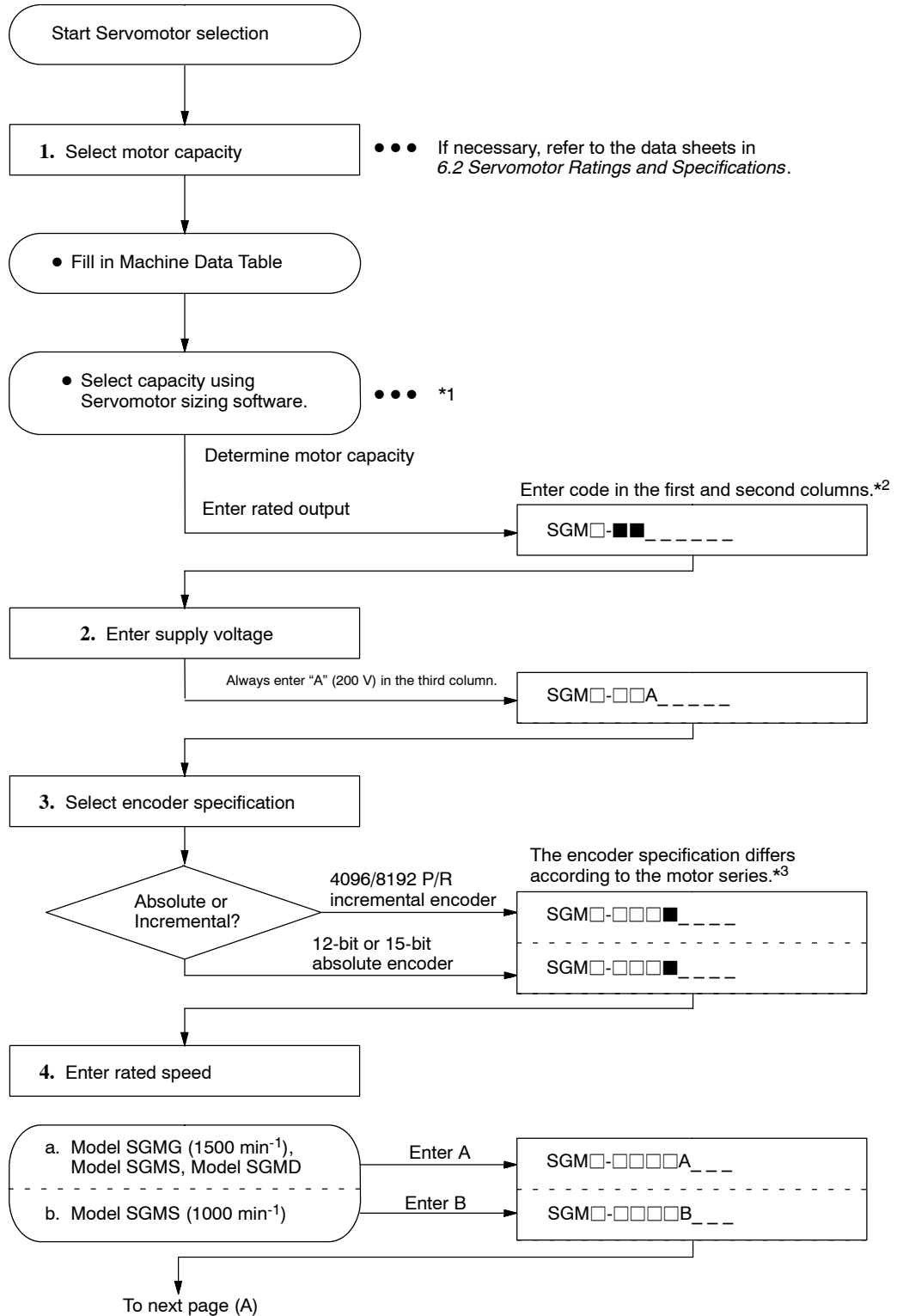

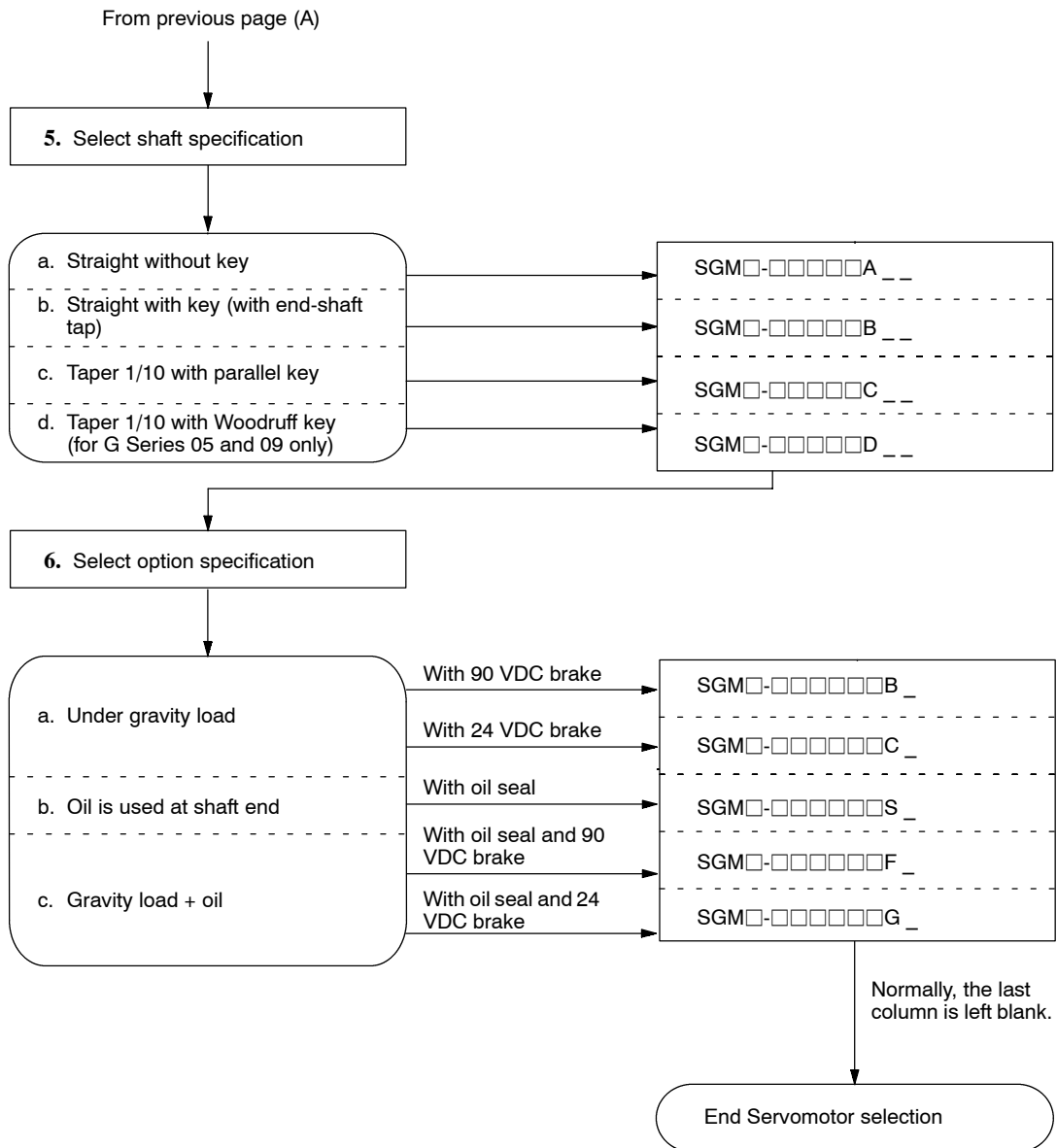

6

*1. Consult your Yaskawa sales representative for further information.

*2. Rated output

Motor capacity (kW)

Series Code	G		S	D
	1500 min ⁻¹	1000 min ⁻¹	3000 min ⁻¹	2000 min ⁻¹
03		0.3		
05	0.45			
06		0.6		
09	0.85	0.9		
10			1.0	

Code \ Series	G		S	D
	1500 min ⁻¹	1000 min ⁻¹	3000 min ⁻¹	2000 min ⁻¹
12		1.2		
13	1.3			
15			1.5	
20	1.8	2.0	2.0	
22				2.2
30	2.9	3.0	3.0	
32				3.2
40			4.0	4.0
44	4.4	4.4		
50			5.0	
55	5.5			
60		6.0		
75	7.5			
1A	11.0			
1E	15.0			

*3. Encoder specification

Symbol	Specifications	SGMG	SGMS	SGMD
2	Incremental encoder: 8192 P/R	◎	○	○
6	Incremental encoder: 4096 P/R	○	◎	○
W	Absolute encoder: 12 bits (1024 P/R)	○	○	◎
S	Absolute encoder: 15 bits (8192 P/R)	○	○	○

◎ : Standard ○ : Non-standard

■ Selecting an SGM or SGMP Servomotor

Models

Each model can be identified by specifying a 7-digit alphanumeric code following either “SGM-” or “SGMP-” according to the servo system to be used. Numbers 1 to 6 in the explanation below correspond to 1 through 6 in the Flowchart for Servomotor Selection on following pages.

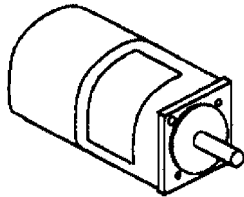
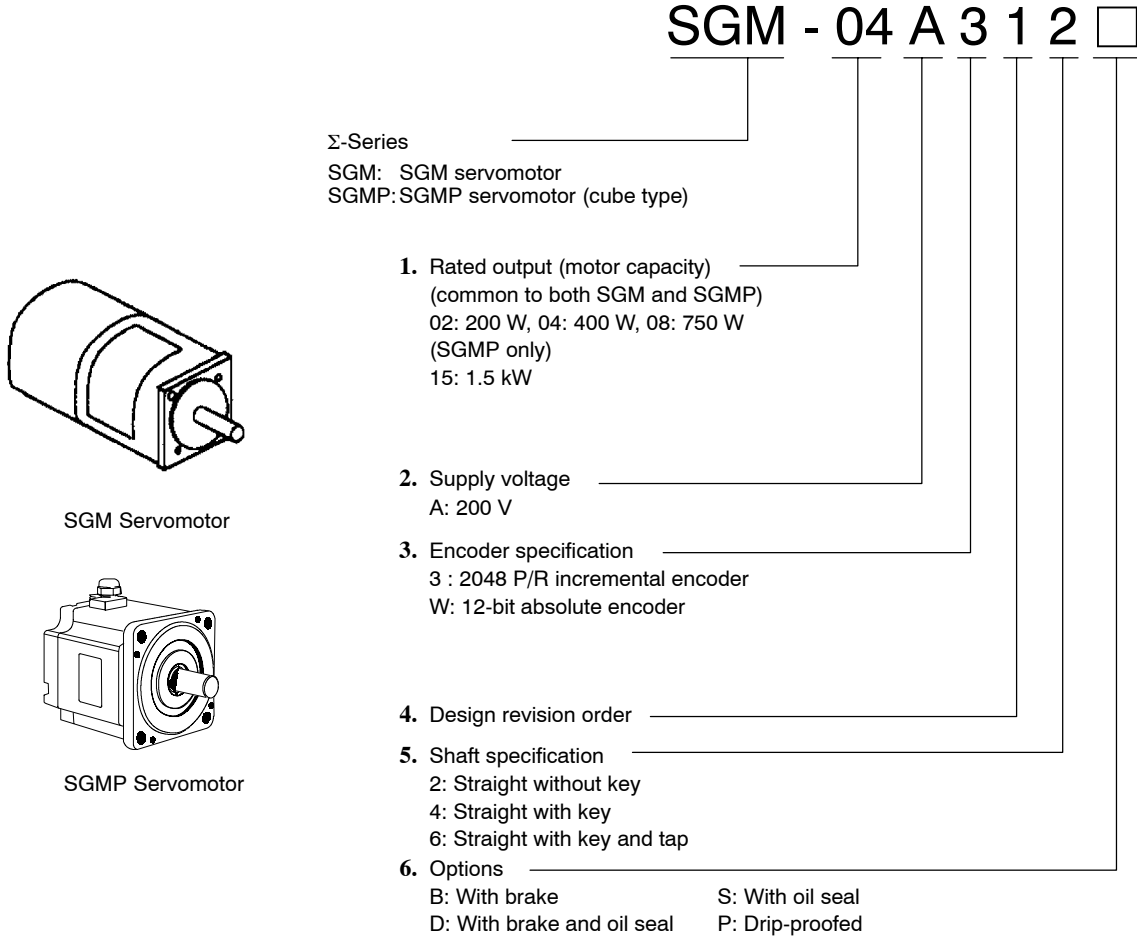

SGM Servomotor

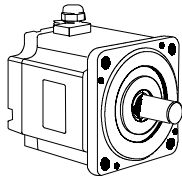

SGMP Servomotor



Flowchart for Servomotor selection

	Selected Motor Model
Example	SGM- 0 4 A W 1 4 B
Axis 1	SGM- □ □ □ □ □ □ □
Axis 2	SGM- □ □ □ □ □ □ □
• • •	• • • •

Flowchart for Servomotor Selection

The actual selection of SGM or SGMP Servomotors is made according to the following flowchart.

If an SGMP Servomotor is selected, replace “SGM” with “SGMP.”

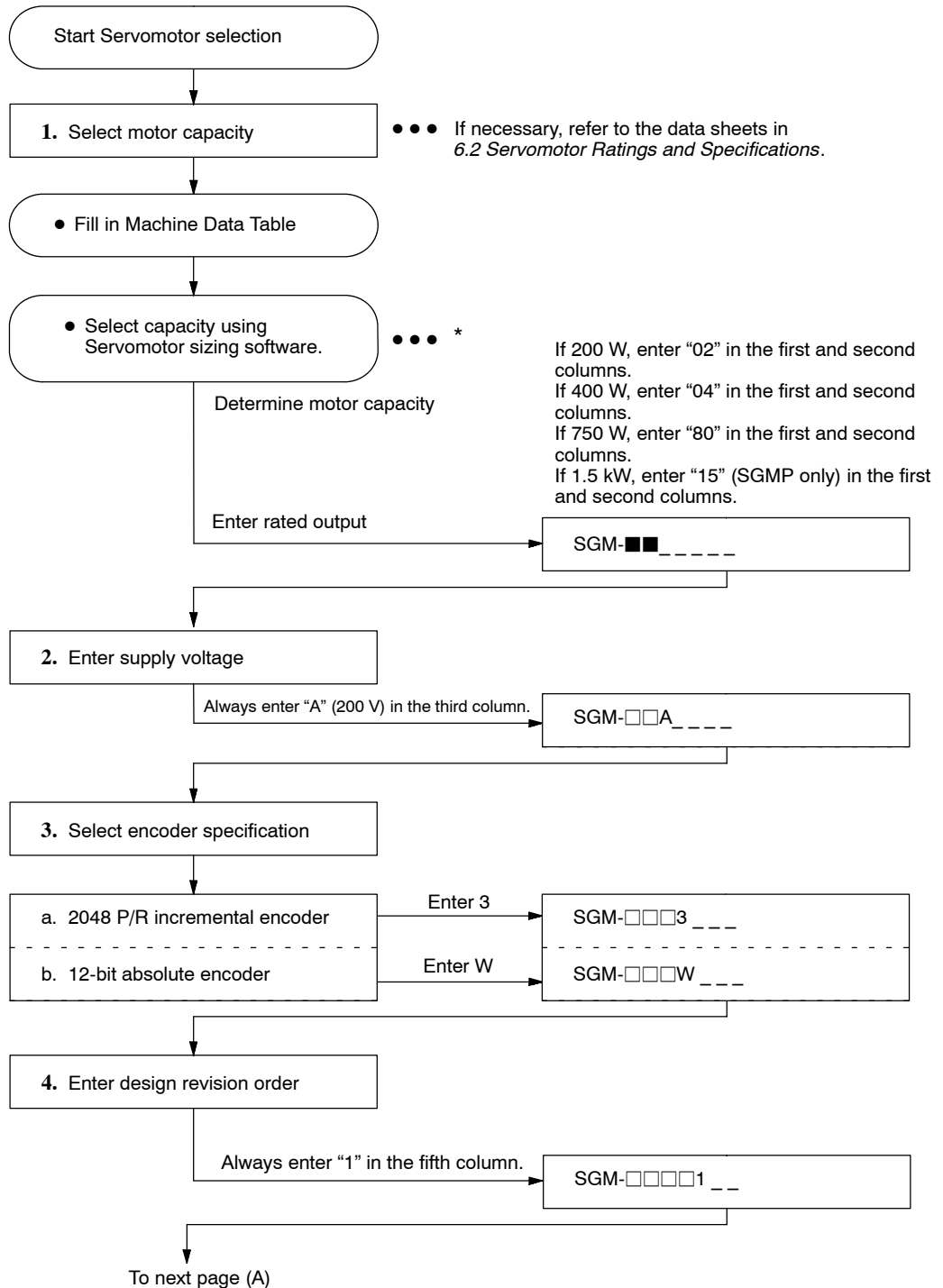

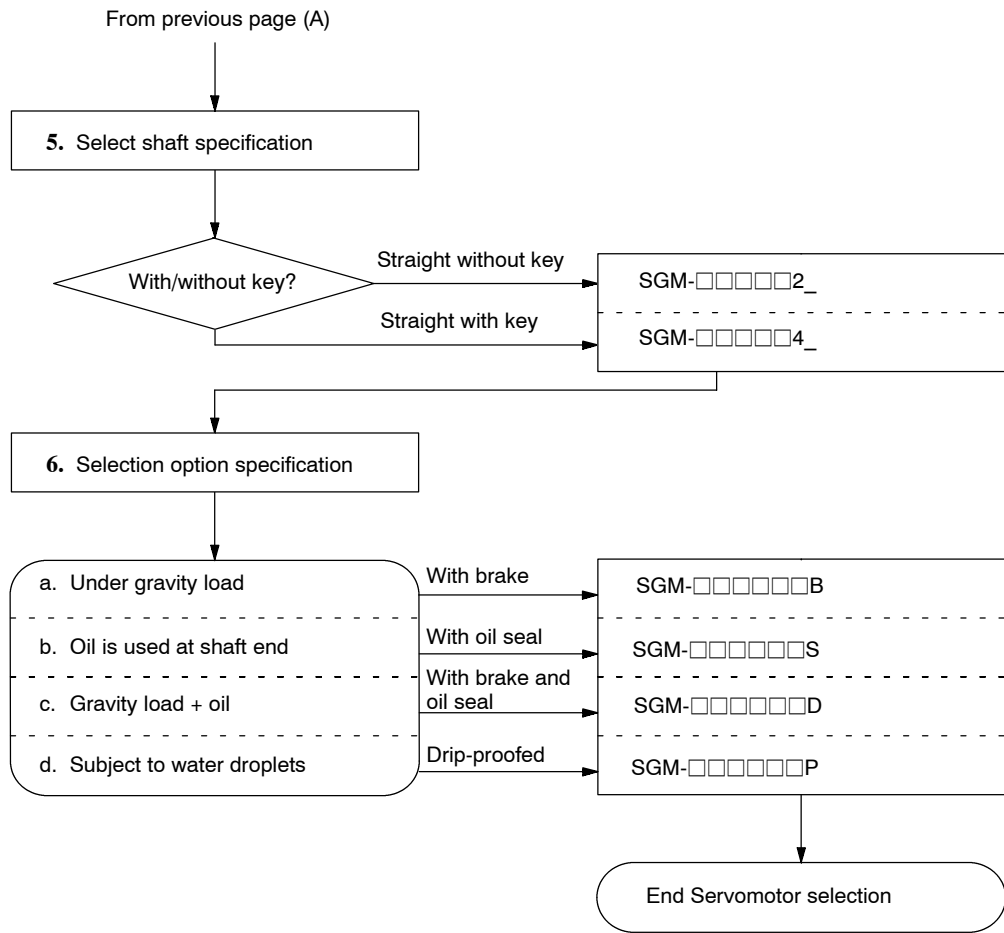

* Consult your Yaskawa sales representative for further information.

Machine Data Table

Fill out the machine data table below as an aid to selecting the drive system. When the machine data table is complete, use the servomotor sizing software to select the motor capacity.

Table 6.1 Machine Data Table

Ball Screw Horizontal Axis			
*1	Load mass	W	_____kg (lb)
	Thrust	F	_____kg (lb)
	Coefficient of friction	μ	_____
	Overall efficiency	η	_____
*2	Gear ratio	$R (= Nm/N\ell)$	_____
*3	Gear+coupling	GD^2g	_____kg·cm ² (lb·in ² .)
	Ball screw pitch	P	_____mm (in.)
	Ball screw diameter	D	_____mm (in.)
	Ball screw length	L	_____mm (in.)

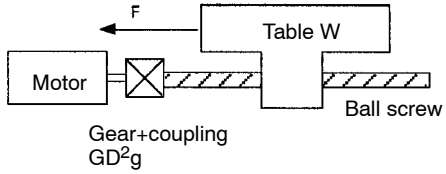

Ball Screw Vertical Axis			
	Load mass	W_1	_____kg (lb)
	Counterweight	W_2	_____kg (lb)
	Coefficient of friction	μ	_____
	Overall efficiency	η	_____
	Gear ratio	$R (= Nm/N\ell)$	_____
	Gear+coupling	GD^2g	_____kg·cm ² (lb·in ² .)
	Ball screw pitch	P	_____mm (in.)
	Ball screw diameter	D	_____mm (in.)
	Ball screw length	L	_____mm (in.)

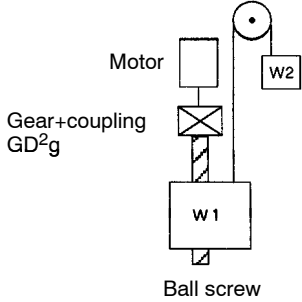

Timing Belt

Load mass	W	_____kg (lb)
Thrust	F	_____kg (lb)
Coefficient of friction	μ	_____
Overall efficiency	η	_____
Gear ratio	$R (= Nm/N\ell)$	_____
Gear+coupling	GD^2g	_____kg·cm ² (lb·in ² .)
Pulley	GD^2d	_____kg·cm ² (lb·in ² .)
Pulley diameter	D	_____mm (in.)

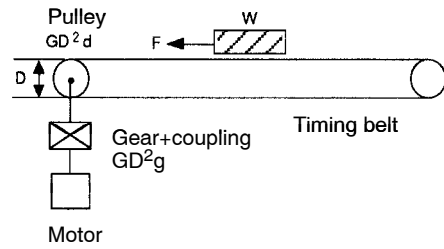

Rack and Pinion

Load mass	W	_____kg (lb)
Thrust	F	_____kg (lb)
Coefficient of friction	μ	_____
Overall efficiency	η	_____
Gear ratio	$R (= Nm/N\ell)$	_____
Gear+coupling	GD^2g	_____kg·cm ² (lb·in ² .)
Pinion diameter	D	_____mm (in.)
Pinion thickness	t	_____mm (in.)

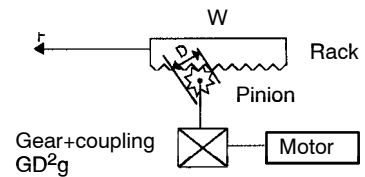

Roll Feeder

Load GD^2	$GD^2\ell$	_____kg·cm ² (lb·in ² .)
Tension	F	_____kg (lb)
Press force	P	_____kg (lb)
Roller diameter	D	_____mm (in.)
Coefficient of friction	μ	_____
Overall efficiency	η	_____
Gear ratio	R (= Nm/N ℓ)	_____
Gear+coupling	GD^2g	_____kg·cm ² (lb·in ² .)

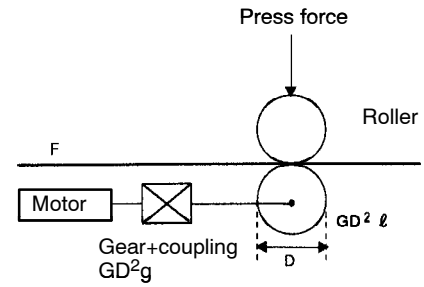
**Rotor**

Load GD^2	$GD^2\ell$	_____kg·cm ² (lb·in ² .)
Load torque	$T\ell$	_____kg·cm (lb·in ² .)
Overall efficiency	η	_____
Gear ratio	R (= Nm/N ℓ)	_____
Gear+coupling	GD^2g	_____kg·cm ² (lb·in ² .)

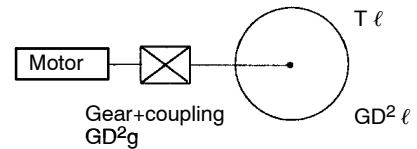
**Others**

Load GD^2	$GD^2\ell$	_____kg·cm ² (lb·in ² .)
Load torque	$T\ell$	_____kg·cm (lb·in ² .)
Motor speed	Nm	_____min ⁻¹
DUTY	td	_____s
Positioning time	ts	_____s
Accel/decel time	ta	_____s

6.1.1 Selecting a Servomotor

Duty cycle

DUTY	t_d	_____s
Positioning distance	L_s	_____mm (in.)
Moving part speed	V_ℓ	_____m/min
Positioning time	t_s	_____s
Accel/decel time	t_a	_____s

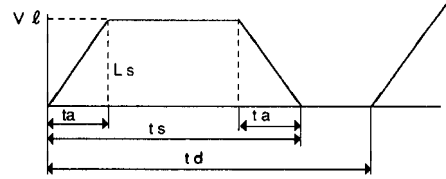

Enter either V_ℓ or t_s . If both are entered, specify priority.

- Operating environment
- Operating temperature
- Other

- * 1. GD^2 (inertia) of Table W (load weight) and GD^2 (inertia) of the motor are automatically calculated by the servomotor sizing software.
- * 2. Gear ratio $R = N_m/N_\ell = \text{motor-speed/load-speed}$
- * 3. Gear+coupling GD^2 g: GD^2 of gear or coupling
This is GD^2 of the joint (including a gear) between the motor and the load (machine).

6.1.2 Selecting a SERVOPACK

This section explains each model of SERVOPACK and applicable Servomotors.

■ Models

Select an SGDB SERVOPACK according to the servo system to be used. Each model can be identified by specifying a 4-digit alphanumeric code following “SGDB-”. Refer to the *Table 6.2*.

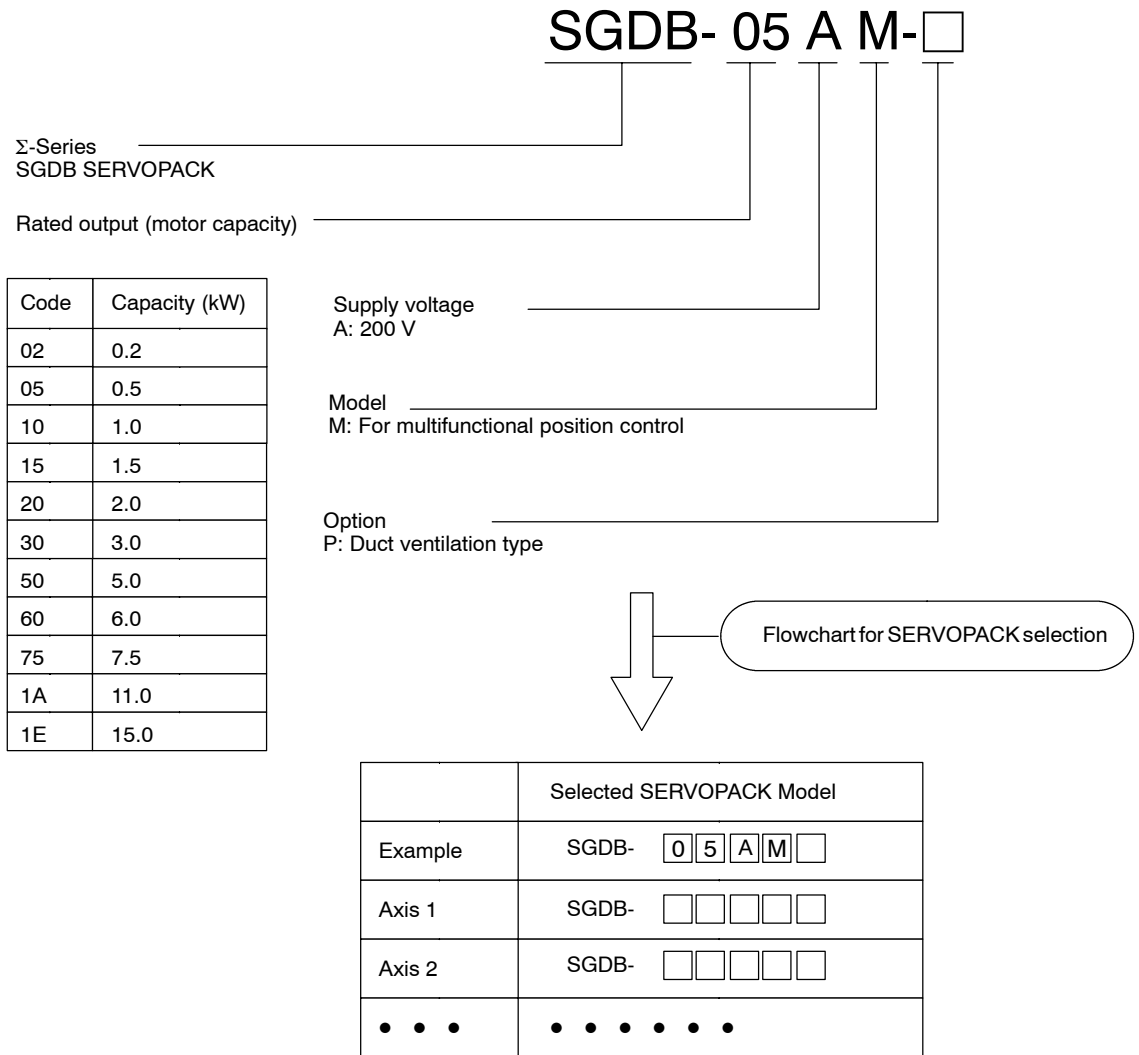

■ Correspondence between SERVOPACKs and Servomotors

The SERVOPACK to be selected is determined by the motor being used. Refer to the following table to select an appropriate SERVOPACK. The motor to be used can also be changed among applicable motors within the same group by setting the parameter.

Table 6.2 Correspondence between SERVOPACKs and Servomotors

Group	SERVOPACK Model	Applicable Motor Model
02	SGDB-02AM	SGM-02A
		SGMP-02A
05	SGDB-05AM	SGMG-03A□B
		SGM-04A
		SGMP-04A
		SGMG-05A□A
10	SGDB-10AM	SGMG-06A□B
		SGM-08A
		SGMP-08A
		SGMG-09A□A
		SGMG-09A□B
		SGMS-10A□A
15	SGDB-15AM	SGMG-12A□B
		SGMG-13A□A
		SGMP-15A
		SGMS-15A□A
20	SGDB-20AM	SGMG-20A□A
		SGMG-20A□B
		SGMS-20A□A
30	SGDB-30AM	SGMD-22A□A
		SGMG-30A□A
		SGMG-30A□B
		SGMS-30A□A

Group	SERVOPACK Model	Applicable Motor Model
50	SGDB-50AM	SGMD-32A□A
		SGMG-44A□A
		SGMG-44A□B
		SGMS-40A□A
		SGMD-40A□A
		SGMS-50A□A
60	SGDB-60AM	SGMG-55A□A
		SGMG-60A□B
75	SGDB-75AM	SGMG-75A□A
1A	SGDB-1AAM	SGMG-1AA□A
1E	SGDB-1EAM	SGMG-1EA□A

6.1.3 Selecting a Digital Operator

The following two models of Digital Operator are available. Each model differs in shape but the operating functions are identical.

The two models cannot be used simultaneously. However, it is convenient to have both models and use whichever suits the circumstances.

6

■ Models of Digital Operator

- JUSP-OP03A (Mounted)

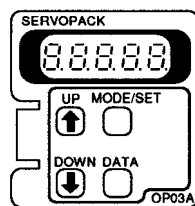

Use attached to the top of the SERVOPACK front face.

- JUSP-OP02A-1 (Hand-held)

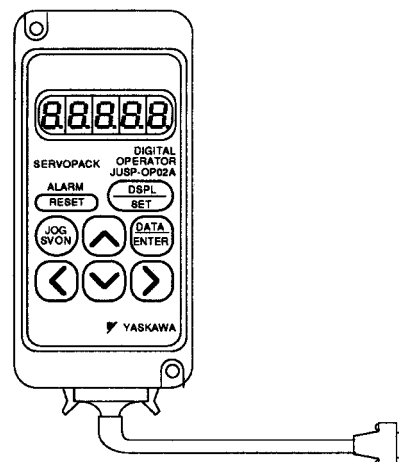

Use held in the hand while connected with the 1 m cable supplied.

Figure 6.1 Digital Operator

■ Digital Operator Selection

Select the Digital Operator according to the flowchart below.

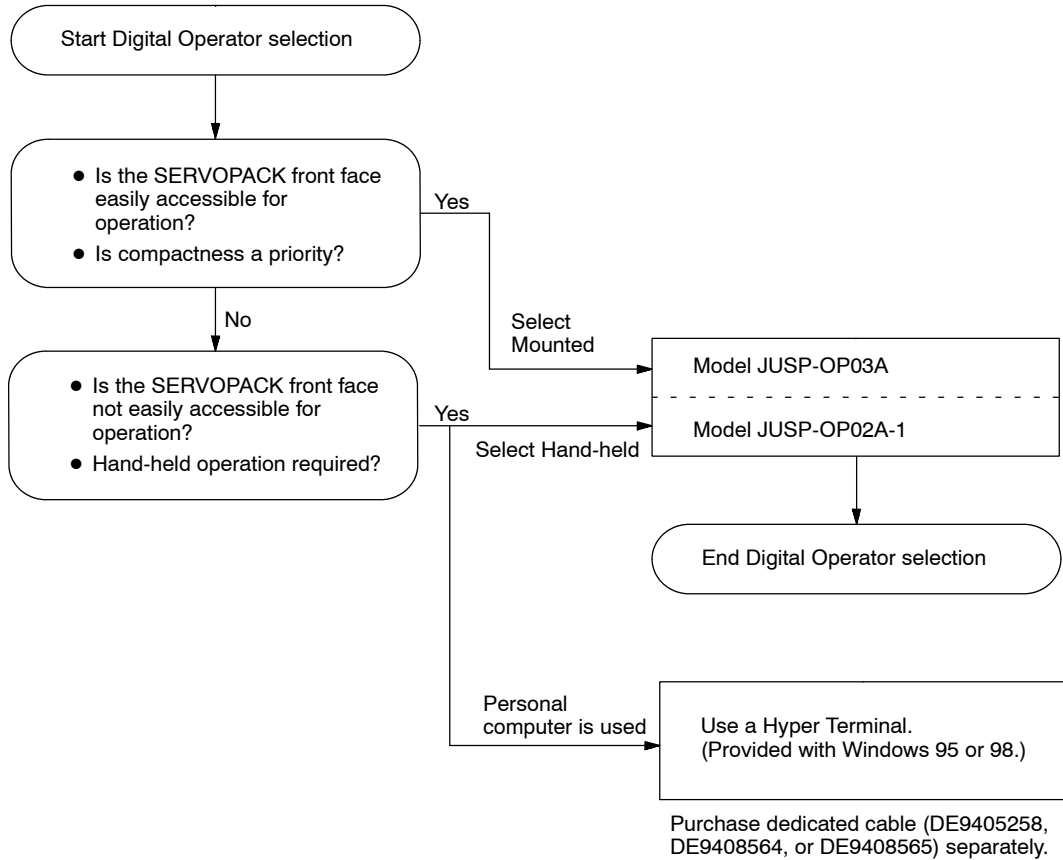

Figure 6.2 Flowchart for Digital Operator Selection

6.2 Servomotor Ratings and Specifications

This section presents tables of ratings and specifications for Servomotors. Refer to these tables when selecting a Servodrive.

6.2.1 Ratings and Specifications

The ratings and specifications of each Servomotor model are shown below.

■ SGMG Servomotors (Rated Motor Speed is 1500 min⁻¹)

Ratings and Specifications

Time rating:	Continuous
Insulation class:	Class F
Vibration class:	15 µm or below
Withstand voltage:	1500 VAC
Insulation resistance:	500 VDC 10 MΩ min.
Enclosure:	Totally enclosed, self-cooled IP67(except for shaft opening)
Ambient temperature:	0 to 40°C
Ambient humidity:	20% to 80% (non-condensing)
Excitation:	Permanent magnet
Drive method:	Direct drive
Mounting:	Flange method

**Table 6.3 Ratings and Specifications of SGMG Servomotors
(Rated Motor Speed is 1500 min⁻¹)**

Servomotor SGMG-		05A□ A	09A□ A	13A□ A	20A□ A	30A□ A	44A□ A	55A□ A	75A□ A	1AA□ A	1EA□ A
Rated Output*	kW (HP)	0.45 (0.6)	0.85 (1.1)	1.3 (1.7)	1.8 (2.4)	2.9 (3.9)	4.4 (5.9)	5.5 (7.4)	7.5 (10)	11 (15)	15 (20)
	Rated Torque*	N-m	2.84	5.39	8.34	11.5	18.6	28.4	35.0	48.0	70.0
Instantaneous Peak Torque*	kgf-cm (lb-in)	29 (25)	55 (48)	85 (74)	117 (102)	190 (165)	290 (252)	357 (310)	490 (425)	714 (620)	974 (845)
	N-m	8.92	13.8	23.3	28.7	45.1	71.1	87.6	119	175	224
Rated Current	kgf-cm (lb-in)	91 (79)	141 (122)	238 (207)	293 (254)	460 (404)	725 (630)	894 (775)	1210 (1050)	1790 (1550)	2290 (1988)
	A (rms)	3.8	7.1	10.7	16.7	23.8	32.8	42.1	54.7	58.6	78.0

6.2.1 Ratings and Specifications

Servomotor SGMG-		05A□ A	09A□ A	13A□ A	20A□ A	30A□ A	44A□ A	55A□ A	75A□ A	1AA□ A	1EA□ A	
Instantaneous Max Current*	A (rms)	11	17	28	42	56	84	110	130	140	170	
Rated Speed*	min ⁻¹	1500										
Instantaneous Max Speed*	min ⁻¹	3000									2000	
Torque Constant	N·m/A (rms)	0.82	0.83	0.84	0.73	0.83	0.91	0.88	0.93	1.25	1.32	
	kgf·cm/A (lb·in/A) (rms)	8.4 (7.3)	8.4 (7.3)	8.6 (7.4)	7.5 (6.5)	8.5 (7.3)	9.2 (8.0)	9.0 (7.8)	9.4 (8.2)	12.8 (11)	13.5 (11.7)	
Moment of Inertia	kg·m ² × 10 ⁻⁴	7.24	13.9	20.5	31.7	46.0	67.5	89.0	125	281	315	
	gf·cm·s ² (lb·in·s ² × 10 ⁻³)	7.39 (6.41)	14.2 (12.3)	20.9 (18.2)	32.3 (28.1)	46.9 (40.7)	68.9 (59.8)	90.8 (78.8)	127 (111)	287 (249)	321 (279)	
Rated Power Rate*	kW/s	11.2	20.9	33.8	41.5	75.3	120	137	184	174	289	
Rated Angular Acceleration*	rad/s ²	3930	3880	4060	3620	4050	4210	3930	3850	2490	3030	
Inertia Time Constant	ms	5.0	3.1	2.8	2.1	1.9	1.3	1.3	1.1	1.2	0.98	
Inductive Time Constant	ms	5.1	5.3	6.3	12.5	12.5	15.7	16.4	18.4	22.6	27.2	

* These items and torque-speed characteristics quoted in combination with an SGDB SERVOPACK at an armature winding temperature of 20°C.

Note: These characteristics can be obtained when the following heat sinks (steel plates) are used for cooling purposes:

Model 05A□A to 13A□A: 400×400×20 mm (15.75×15.75×0.79 in)

Model 20A□A to 75A□A: 550×550×30 mm (21.65×21.65×1.18 in)

Model 1AA□A to 1EA□A: 650×650×35 mm (25.59×25.59×1.38 in)

IMPORTANT

The ratings and specifications on the previous pages refer to a standard Servomotor.

Add the numerical values below to the moment of inertia values in the *Table 6.3* for a motor fitted with a holding brake. Other specifications will also change slightly.

Servomotor SGMG-			05A A	09A A	13A A	20A A	30A A	44A A	55A A	75A A	1AA A	1EA A
With Holding Brake	Moment of Inertia Increase	$\text{kg}\cdot\text{m}^2 \times 10^{-4}$	2.1			8.5			8.5		18.8	37.5
		$\text{gf}\cdot\text{cm}\cdot\text{s}^2$ ($\text{lb}\cdot\text{in}\cdot\text{s}^2 \times 10^{-3}$)	2.14 (1.86)			8.67 (7.54)			8.67 (7.54)		19.2 (16.7)	38.3 (33.2)
	Static Friction Torque	N·m (lb·in)	4.41 (39)	12.7 (112)	20.0 (177)	43.1 (381)			72.6 (643)		84.3 (746)	114.7 (1015)

Holding Brake, 90 VDC Rating

Servomotor SGMG-		05A A	09A A	13A A	20A A	30A A	44A A	55A A	75A A	1AA A	1EA A
Coil Resistance (at 20°C)	Ω	803.5			438			345		253	231
Rated Current (at 20°C)	A	0.11			0.21			0.26		0.36	0.39
Capacity	W	10.1			18.5			23.5		32.0	35.0

Holding Brake, 24 VDC Rating

Servomotor SGMG-		05A A	09A A	13A A	20A A	30A A	44A A	55A A	75A A	1AA A	1EA A
Coil Resistance (at 20°C)	Ω	58.5			31.1			24.5		18.0	16.4
Rated Current (at 20°C)	A	0.41			0.77			0.98		1.33	1.46
Capacity	W	9.85			18.5			23.5		32.0	35.0



◆ Holding Brake

The holding brake is automatically applied to the motor shaft to prevent the load falling in vertical axis applications when the motor power supply is turned off or fails. It is only to hold the load and cannot be used for stopping the motor.

Torque-Motor Speed Characteristics

SGMG Servomotor (Rated Motor Speed is 1500 min⁻¹) Torque-Motor Speed Characteristics

SGMG-05A□A

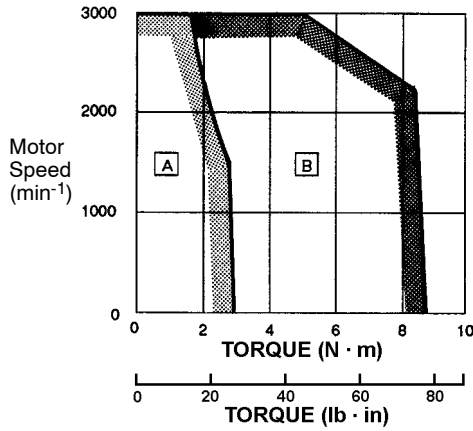

SGMG-09A□A

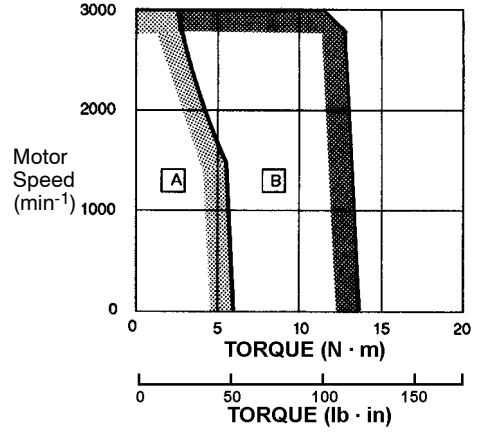

SGMG-13A□A

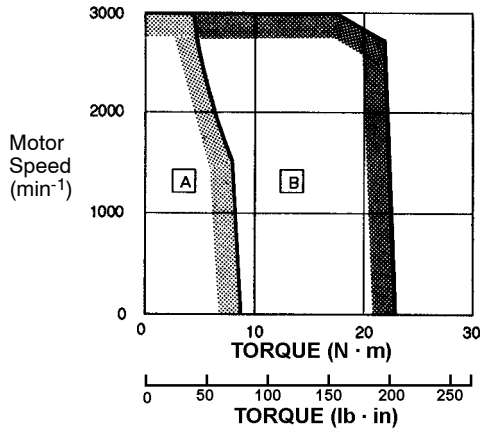

SGMG-20A□A

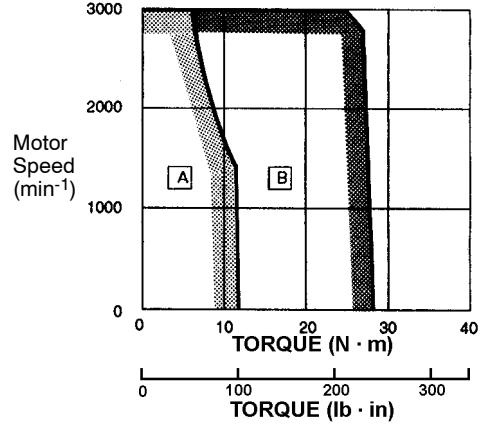

SGMG-30A□A

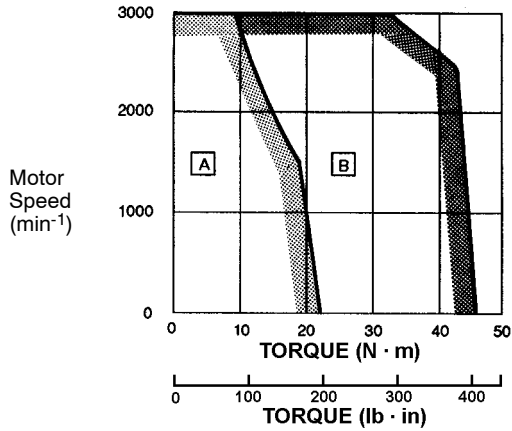

SGMG-44A□A

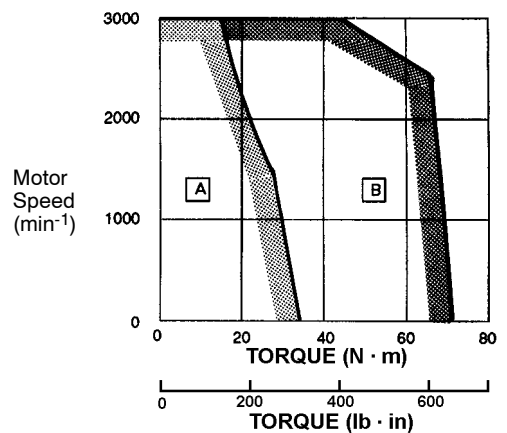

A: Continuous Duty Zone
B: Intermittent Duty Zone

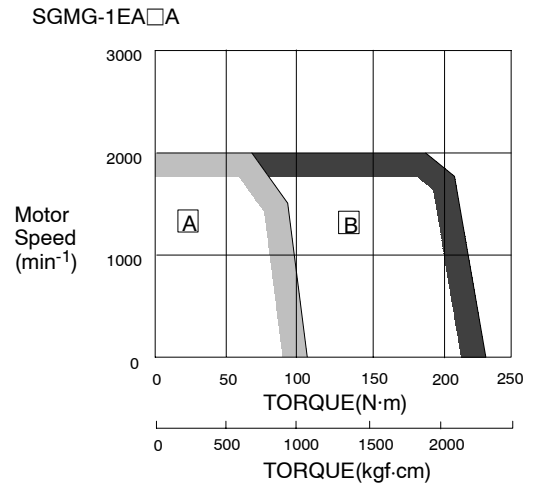
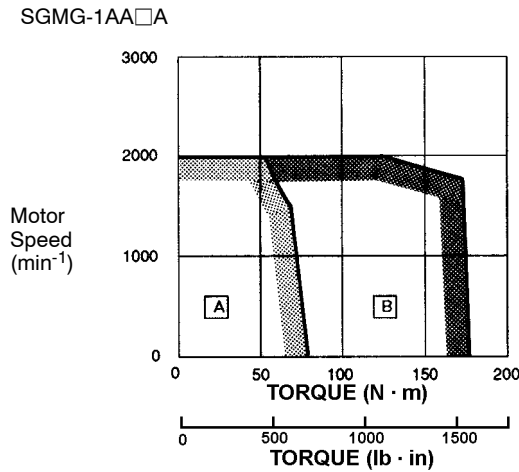
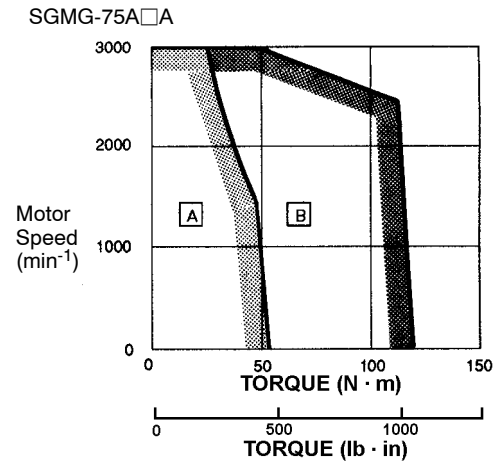
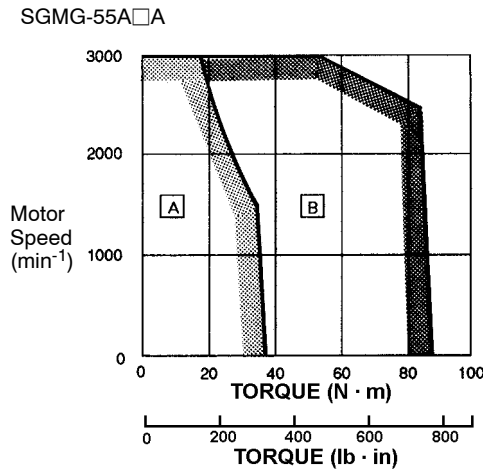

A: Continuous Duty Zone
 B: Intermittent Duty Zone

■ SGMG Servomotors (Rated Motor Speed is 1000 min⁻¹)

Ratings and Specifications

- Time rating: Continuous
- Insulation class: Class F
- Vibration class: 15 μm or below
- Withstand voltage: 1500 VAC
- Insulation resistance: 500 VDC 10 MΩ min.
- Enclosure: Totally enclosed, self-cooled
IP67 (except for shaft opening)
- Ambient temperature: 0 to 40°C
- Ambient humidity: 20% to 80% (non-condensing)
- Excitation: Permanent magnet
- Drive method: Direct drive
- Mounting: Flange method

**Table 6.4 Ratings and Specifications of SGMG Servomotors
(Rated Motor Speed Is 1000 min⁻¹)**

Servomotor SGMG-		03A□B	06A□B	09A□B	12A□B	20A□B	30A□B	44A□B	60A□B
Rated Output*	kW (HP)	0.3 (0.4)	0.6 (0.8)	0.9 (1.2)	1.2 (1.6)	2.0 (2.7)	3.0 (4.0)	4.4 (5.9)	6.0 (8.0)
Rated Torque *	N-m	2.84	5.68	8.62	11.5	19.1	28.4	41.9	57.2
	kgf·cm (lb·in)	29 (25)	58 (50)	88 (76)	117 (102)	195 (169)	290 (252)	428 (372)	584 (508)
Instantaneous Peak Torque*	N-m	7.17	14.1	19.3	28.0	44.0	63.7	107	129
	kgf·cm (lb·in)	73.2 (63)	144 (125)	197 (171)	286 (248)	449 (390)	650 (564)	1090 (947)	1320 (1140)
Rated Current	A (rms)	3.0	5.7	7.6	11.6	18.5	24.8	32.9	46.9
Instantaneous Max Current*	A (rms)	7.3	13.9	16.6	28	42	56	84	110
Rated Speed*	min ⁻¹	1000							
Instantaneous Max Speed*	min ⁻¹	2000							
Torque Constant	N·m/A (rms)	1.03	1.06	1.21	1.03	1.07	1.19	1.34	1.26
	kgf·cm/A (lb·in/A) (rms)	10.5 (9.12)	10.8 (9.38)	12.4 (10.7)	10.5 (9.12)	11.0 (9.47)	12.1 (10.5)	13.7 (11.9)	12.9 (11.2)
Moment of Inertia	kg·m ² × 10 ⁻⁴	7.24	13.9	20.5	31.7	46.0	67.5	89.0	125
	gf·cm·s ² (lb·in·s ² × 10 ⁻³)	7.39 (6.41)	14.2 (12.3)	20.9 (18.2)	32.3 (28.1)	46.9 (40.7)	68.9 (59.8)	90.8 (78.8)	127 (111)
Rated Power Rate*	kW/s	11.2	23.2	36.3	41.5	79.4	120	198	262
Rated Angular Acceleration*	rad/s ²	3930	4080	4210	3620	4150	4210	4710	4590
Inertia Time Constant	ms	5.1	3.8	2.8	2.0	1.7	1.4	1.3	1.1
Inductive Time Constant	ms	5.1	4.7	5.7	13.5	13.9	15.5	14.6	16.5

* These items and torque-speed characteristics quoted in combination with an SGDB SERVOPACK at an armature winding temperature of 20°C.

Note: These characteristics can be obtained when the following heat sinks (steel plates) are used for cooling purposes:

Model 03A□B to 09A□B: 400×400×20 mm (15.75×15.75×0.79 in)

Model 12A□B to 60A□B: 550×550×30 mm (21.65×21.65×1.18 in)

IMPORTANT

The ratings and specifications on the previous pages refer to a standard Servomotor.

Add the numerical values below to the moment of inertia values in the *Table 6.4* for a motor fitted with a holding brake. Other specifications will also change slightly.

Servomotor SGMG			03A□B	06A□B	09A□B	12A□B	20A□B	30A□B	44A□B	60A□B
With Holding Brake	Moment of Inertia Increase	kg·m ² × 10 ⁻⁴	2.1			8.5				
		gf·cm·s ² (lb·in·s ² × 10 ⁻³)	2.14 (1.86)			8.67 (7.54)				
	Static Friction Torque	N·m (lb·in)	4.41 (39)	12.7 (112)	20.0 (177)	43.1 (381)			72.6 (643)	

Holding Brake, 90 VDC Rating

Servomotor SGMG-		03A□B	06A□B	09A□B	12A□B	20A□B	30A□B	44A□B	60A□B
Coil Resistance (at 20°C)	Ω	803.5			438			345	
Rated Current (at 20°C)	A	0.11			0.21			0.26	
Capacity	W	10.1			18.5			23.5	

Holding Brake, 24 VDC Rating

Servomotor SGMG-		03A□B	06A□B	09A□B	12A□B	20A□B	30A□B	44A□B	60A□B
Coil Resistance (at 20°C)	Ω	58.5			31.1			24.5	
Rated Current (at 20°C)	A	0.41			0.77			0.98	
Capacity	W	9.85			18.5			23.5	

Torque-Motor Speed Characteristics

SGMG Servomotor (Rated Motor Speed is 1000 min^{-1}) Torque-Motor Speed Characteristics

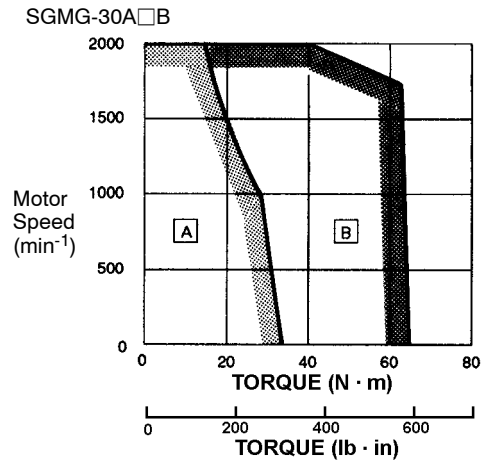
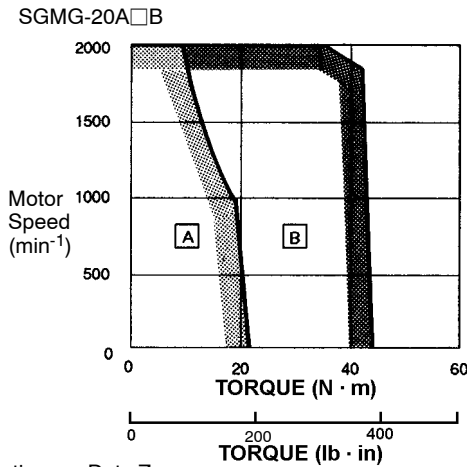
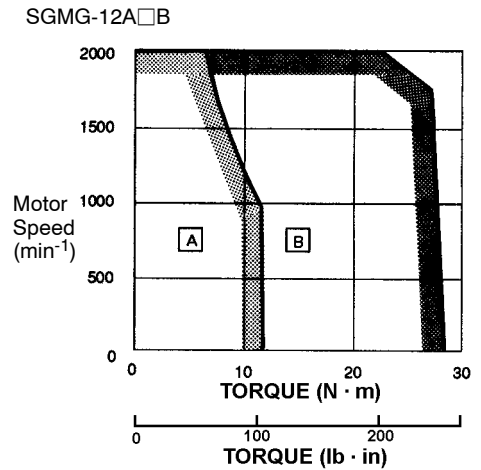
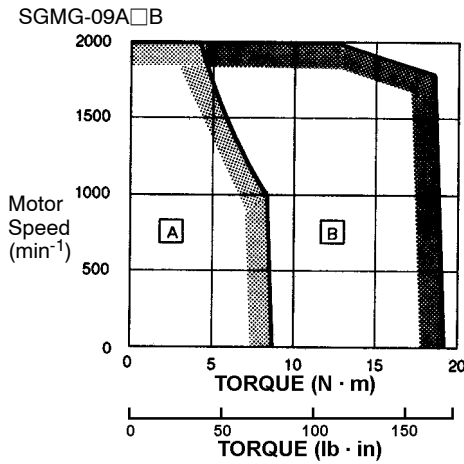
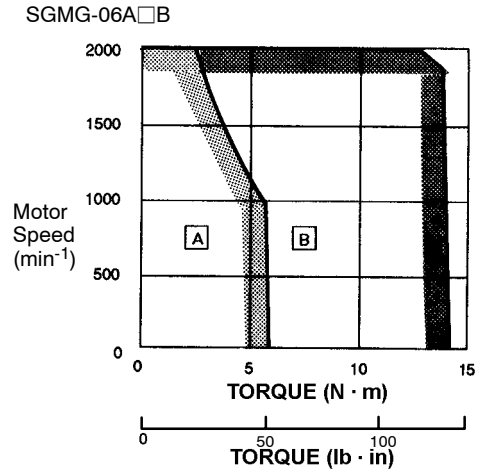
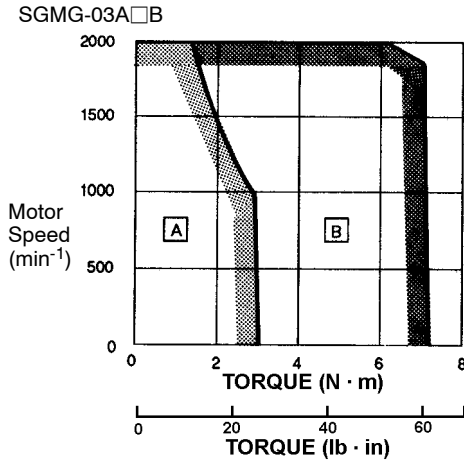

A: Continuous Duty Zone
B: Intermittent Duty Zone

6

SGMG-44A□B

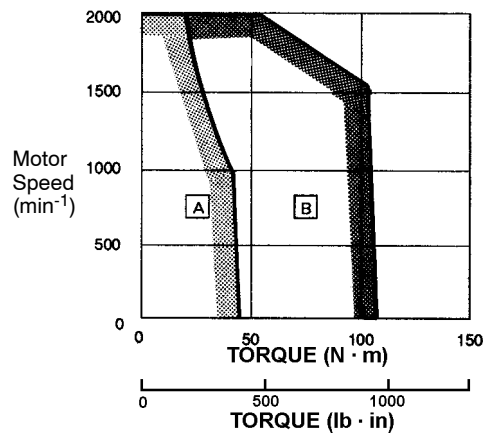

SGMG-60A□B

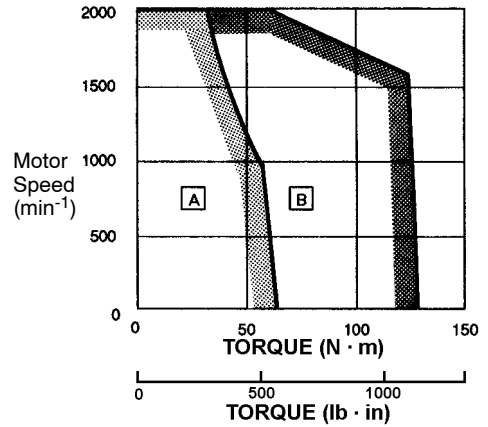

A: Continuous Duty Zone
B: Intermittent Duty Zone

■ SGM Servomotors

Ratings and Specifications

Time rating:	Continuous
Insulation class:	Class F
Vibration class:	15 μ m or below
Withstand voltage:	1500 VAC
Insulation resistance:	500 VDC 10 M Ω min.
Enclosure:	Totally enclosed, self-cooled IP67 (except for shaft opening)
Ambient temperature:	0 to 40°C
Ambient humidity:	20% to 80% (non-condensing)
Excitation:	Permanent magnet
Drive method:	Direct drive
Mounting:	Flange method

Table 6.5 Ratings and Specifications of SGMS Servomotors

Servomotor SGMS		10A□A	15A□A	20A□A	30A□A	40A□A	50A□A
Rated Output*	kW (HP)	1.0 (1.3)	1.5 (2.0)	2.0 (2.7)	3.0 (4.0)	4.0 (5.4)	5.0 (6.7)
	Rated Torque *	N·m	3.18	4.9	6.36	9.8	12.6
	kfg·cm (lb·in)	32.4 (28.2)	50 (43)	65 (56.4)	100 (87)	129 (112)	161 (140)
	Instantaneous Peak Torque*	N·m	9.54	14.7	19.1	29.4	37.8
kfg·cm (lb·in)		97.2 (84.4)	150 (130)	195 (169)	300 (260)	387 (336)	486 (422)
Rated Current	A (rms)	5.7	9.5	12.4	18.8	24.3	28.2
Instantaneous Max Current*	A (rms)	17	28	42	56	77	84
Rated Speed*	min ⁻¹	3000					
Instantaneous Max Speed*	min ⁻¹	4500					
Torque Constant	N·m/A (rms)	0.636	0.573	0.559	0.573	0.55	0.61
	kgf·cm/A (lb·in/A) (rms)	6.49 (5.6)	5.84 (5.1)	5.7 (5.0)	5.84 (5.1)	5.6 (4.9)	6.2 (5.4)
Moment of Inertia	kg·m ² ×10 ⁻⁴	1.74	2.47	3.19	7.00	9.60	12.3
	gf·cm·s ² (lb·in·s ² ×10 ⁻³)	1.78 (1.54)	2.52 (2.19)	3.26 (2.82)	7.14 (6.20)	9.80 (8.50)	12.6 (10.9)
Rated Power Rate*	kW/s	57.9	97.2	127	137	166	202
Rated Angular Acceleration*	rad/s ²	18250	19840	19970	14000	13160	12780
Inertia Time Constant	ms	0.87	0.71	0.58	0.74	0.60	0.57
Inductive Time Constant	ms	7.1	7.7	8.3	13.0	14.1	14.7

* These items and torque-speed characteristics quoted in combination with an SGDB SERVOPACK at an armature winding temperature of 20°C.

Note: These characteristics can be obtained when the following heat sinks (aluminium plates) are used for cooling purposes:

Model 10A□A to 20A□A: 300×300×12 mm (11.81×11.81×0.47 in)

Model 30A□A to 50A□A: 400×400×20 mm (15.75×15.75×0.79 in)

IMPORTANT

The ratings and specifications on the previous pages refer to a standard Servomotor.

Add the numerical values below to the moment of inertia values in the *Table 6.5* for a motor fitted with a holding brake. Other specifications will also change slightly.

Servomotor SGMS-			10A□A	15A□A	20A□A	30A□A	40A□A	50A□A
With Holding Brake	Moment of Inertia Increase	kg·m ² × 10 ⁻⁴	0.325			2.1		
		gf·cm·s ² (lb·in·s ² × 10 ⁻³)	0.332 (0.289)			2.14 (1.86)		
	Static Friction Torque	N·m (lb·in)	7.84 (69)			20 (177)		

Holding Brake, 90 VDC Rating

Servomotor SGMS-			10A□A	15A□A	20A□A	30A□A	40A□A	50A□A
Coil Resistance (at 20°C)	Ω		1150			803.5		
Rated Current (at 20°C)	A		0.08			0.11		
Capacity	W		7.0			10.1		

Holding Brake, 24 VDC Rating

Servomotor SGMS-			10A□A	15A□A	20A□A	30A□A	40A□A	50A□A
Coil Resistance (at 20°C)	Ω		82.0			58.5		
Rated Current (at 20°C)	A		0.29			0.41		
Capacity	W		7.0			9.85		

Torque-Motor Speed Characteristics

SGMS Servomotor Torque-Motor Speed Characteristics

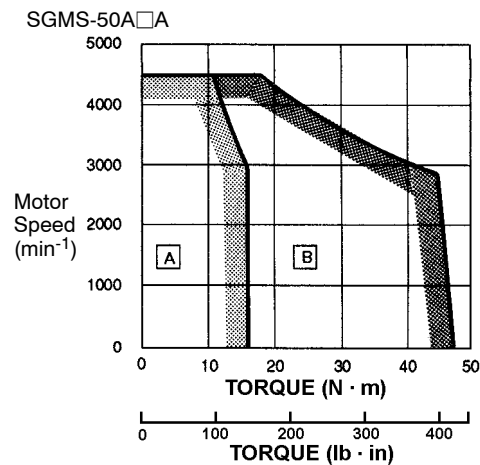
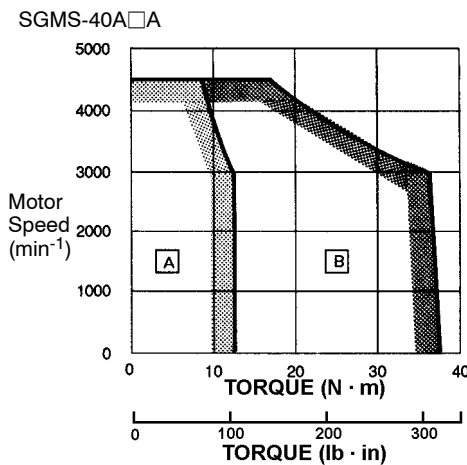
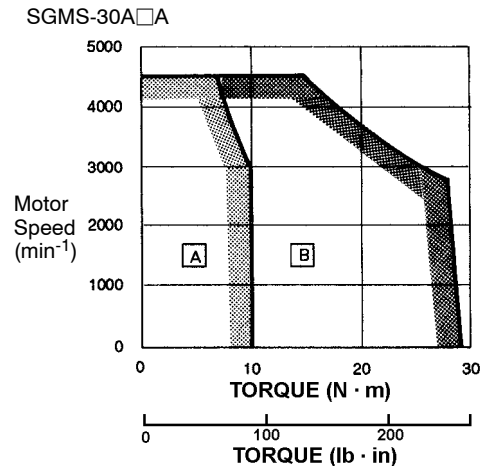
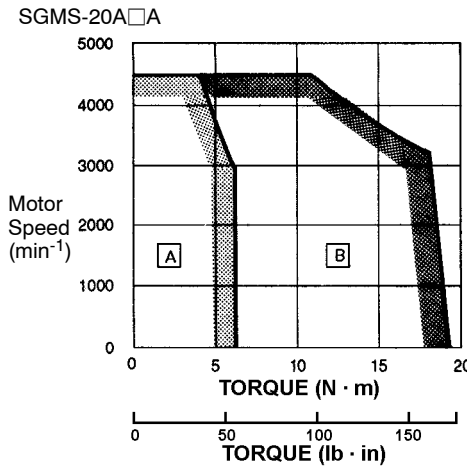
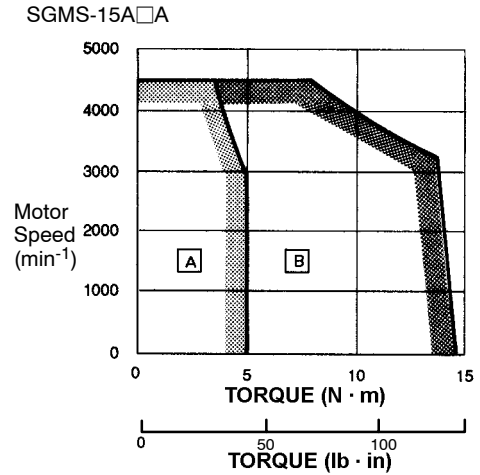
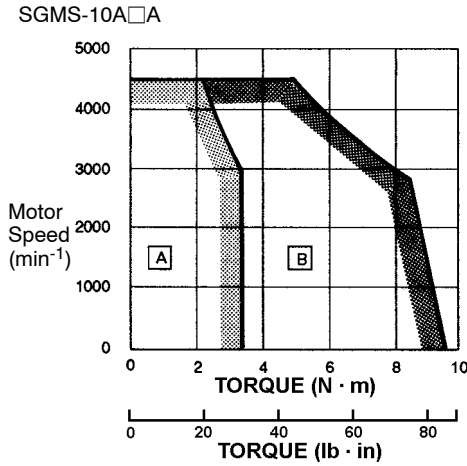

A: Continuous Duty Zone
B: Intermittent Duty Zone

6

■ SGMD Servomotors (with Holding Brake)

Ratings and Specifications

Time rating:	Continuous
Insulation class:	Class F
Vibration class:	15 μm or below
Withstand voltage:	1500 VAC
Insulation resistance:	500 VDC 10 M Ω min.
Enclosure:	Totally enclosed, self-cooled IP67 (except for shaft opening)
Ambient temperature:	0 to 40°C
Ambient humidity:	20% to 80% (non-condensing)
Excitation:	Permanent magnet
Drive method:	Direct drive
Mounting:	Flange method
Holding brake:	90 VDC Static friction torque: 3kgf·m

Table 6.6 Ratings and Specifications of SGMD Servomotors (with Holding Brake)

Servomotor SGMD-		22A□AAB	32A□AAB	40A□AAB
Rated Output*	kW (HP)	2.2 (2.9)	3.2 (4.3)	4.0 (5.4)
Rated Torque *	N·m	10.5	15.3	19.1
	kfg·cm (lb·in)	107 (93)	156 (135)	195 (169)
Instantaneous Peak Torque*	N·m	36.7	53.5	66.9
	kfg·cm (lb·in)	375 (326)	546 (474)	682 (592)
Rated Current	A (rms)	15.7	20.9	22.8
Instantaneous Max Current*	A (rms)	54	73	77
Rated Speed*	min ⁻¹	2000		
Instantaneous Max Speed*	min ⁻¹	3000		
Torque Constant	N·m/A (rms)	0.72	0.78	0.93
	kfg·cm/A(lb·in/A) (rms)	7.4 (6.4)	8.0 (6.9)	9.5 (8.2)
Moment of Inertia	kg·m ² ×10 ⁻⁴	56.6	74.2	91.8
	gf·cm·s ² (lb·in·s ² ×10 ⁻³)	57.8 (50.3)	75.7 (65.9)	93.7 (81.5)
Rated Power Rate*	kW/s	21.6	34.1	42.3
Rated Angular Acceleration*	rad/s ²	2060	2230	2220
Inertia Time Constant	ms	3.1	2.2	1.7
Inductive Time Constant	ms	15.4	18.2	20.9

* These items and torque-speed characteristics quoted in combination with an SGDB SERVOPACK at an armature winding temperature of 20°C.

Note: These characteristics can be obtained when the following heat sinks (steel plates) are used for cooling purposes:
 Model 22A□AAB to 40A□AAB: 650×650×35 mm (25.59×25.59×1.38 in)

Torque-Motor Speed Characteristics

SGMD Servomotor Torque-Motor Speed Characteristics

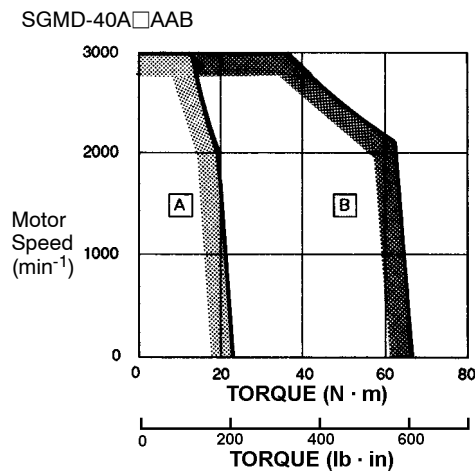
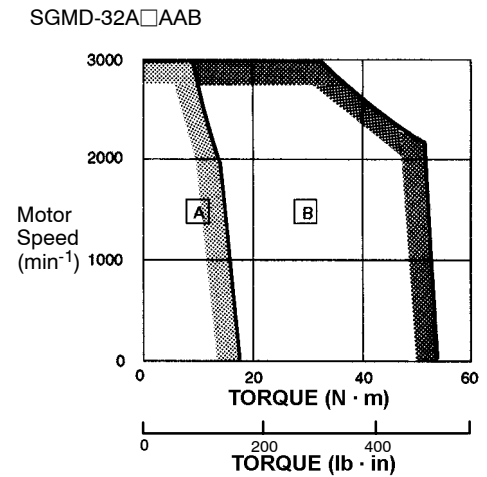
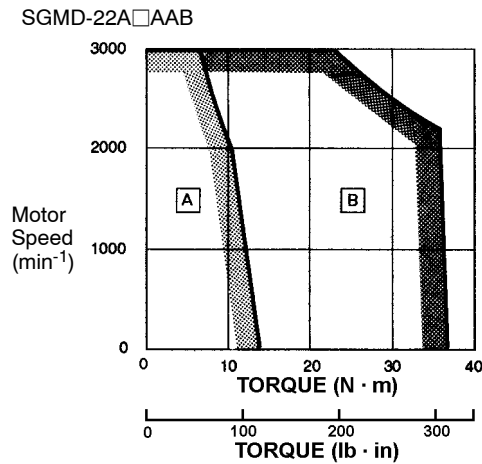

A: Continuous Duty Zone
B: Intermittent Duty Zone

■ SGMP Servomotors

Ratings and Specifications

Time rating:	Continuous
Insulation class:	Class B
Vibration class:	15 μm or below
Withstand voltage:	1500 VAC
Insulation resistance:	500 VDC 10 $\text{M}\Omega$ min.
Enclosure:	Totally enclosed, self-cooled IP67 (except for shaft opening)
Ambient temperature:	0 to 40°C
Ambient humidity:	20% to 80% (non-condensing)
Excitation:	Permanent magnet

6.2.1 Ratings and Specifications

Drive method: Direct drive
 Mounting: Flange method

Table 6.7 Ratings and Specifications of SGMP Servomotors

Servomotor SGMP-		02A	04A	08A	15A
Rated Output* ¹	kW (HP)	0.2 (0.3)	0.4 (0.5)	0.75 (1.0)	1.5 (2.0)
Rated Torque * ¹ * ²	N·m	0.637	1.27	2.39	4.77
	kgf·cm (lb·in)	6.49 (5.64)	13.0 (11.2)	24.3 (21.2)	48.7 (42.2)
Instantaneous Peak Torque* ¹	N·m	1.91	3.82	7.1	14.3
	kgf·cm (lb·in)	19.5 (16.9)	39.0 (33.8)	72.9 (62.8)	146.1 (126.6)
Rated Current	A (rms)	2.0	2.6	4.1	7.5
Instantaneous Max Current* ¹	A (rms)	6.0	8.0	13.9	23.0
Rated Speed*	min ⁻¹	3000			
Instantaneous Max Speed* ¹	min ⁻¹	4500			
Torque Constant	N·m/A (rms)	0.349	0.535	0.641	0.687
	kgf·cm/A (lb·in/A)(rms)	3.56 (3.09)	5.46 (4.74)	6.55 (5.67)	7.01 (6.08)
Moment of Inertia	kg·m ² × 10 ⁻⁴	0.209	0.347	2.11	4.03
	gf·cm·s ² (oz·in·s ² × 10 ⁻³)	0.213 (2.96)	0.354 (4.91)	2.15 (29.9)	4.11 (57.1)
Rated Power Rate* ¹	kW/s	19.4	46.8	26.9	56.6
Rated Angular Acceleration* ¹	rad/s ²	30500	36700	11300	11800
Inertia Time Constant	ms	0.6	0.4	0.7	0.5
Inductive Time Constant	ms	7.4	8.5	18	22

* 1. These items and torque-motor speed characteristics quoted in combination with an SGDBSERVOPACK at an armature winding temperature of 100°C. Other values quoted at 20°C. All values typical.

* 2. Rated torques are continuous allowable torque values at 40°C with a 300 × 300 × 12 (mm) (11.81 × 11.81 × 0.47 (in)) heat sink attached.

6

IMPORTANT

The ratings and specifications on the previous page refer to a standard Servomotor.

Add the numerical values below to the moment of inertia values in the *Table 6.7* for a motor fitted with a holding brake. Other specifications will also change slightly.

Servomotor SGMP-		02A	04A	08A	15A
With Holding Brake	$\text{kg}\cdot\text{m}^2 \times 10^{-4}$	0.098		0.41	0.88
	$\text{gf}\cdot\text{cm}\cdot\text{s}^2$ ($\text{lb}\cdot\text{in}\cdot\text{s}^2 \times 10^{-3}$)	0.100 (0.087)		0.42 (0.36)	0.89 (0.78)
With 12-bit Absolute Encoder	$\text{kg}\cdot\text{m}^2 \times 10^{-4}$	0.025			
	$\text{gf}\cdot\text{cm}\cdot\text{s}^2$	0.026			

The electrical specifications and static friction torque of holding brake are shown below.

Holding Brake, 90 VDC Rating

Servomotor SGMP-		02A	04A	08A	15A
Static Friction Torque	N·m (lb·in)	0.98 (8.67)	1.96 (17.3)	3.63 (32.1)	7.45 (65.9)
Coil Resistance (at 20°C)	Ω	1573	1062	1083	832
Rated Current (at 20°C)	A	0.056	0.085	0.083	0.108
Capacity	W	5	7.6	7.5	10

Holding Brake, 24 VDC Rating

Servomotor SGMP-		02A	04A	08A	15A
Static Friction Torque	N·m (lb·in)	0.98 (8.67)	1.96 (17.3)	3.63 (32.1)	7.45 (65.9)
Coil Resistance (at 20°C)	Ω	116	89	77	58
Rated Current (at 20°C)	A	0.21	0.29	0.31	0.42
Capacity	W	5	7.6	7.5	10

Torque-Motor Speed Characteristics

SGMP Servomotor Torque-Motor Speed Characteristics

SGMP-02A

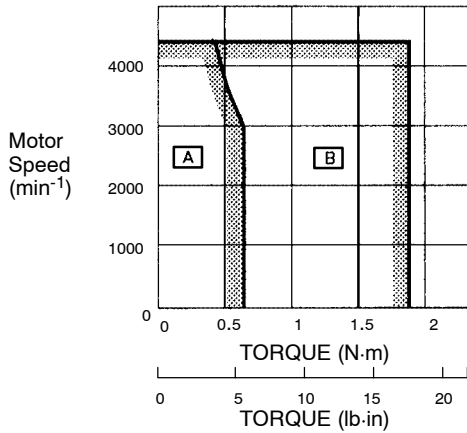

SGMP-04A

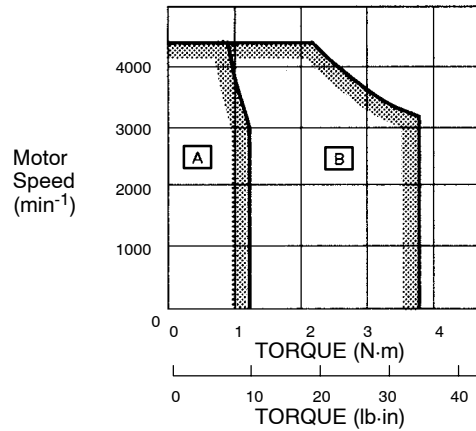

SGMP-08A

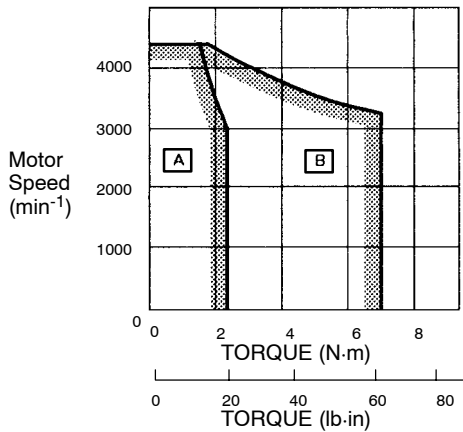

SGMP-15A

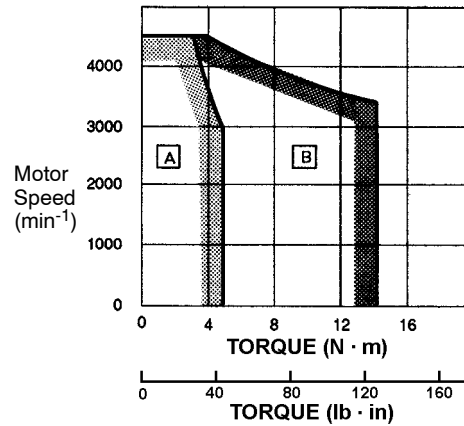

A: Continuous Duty Zone
B: Intermittent Duty Zone

■ Ratings and Specifications of SGM Model

Time rating:	Continuous
Insulation class:	Class B
Vibration class:	15 μ m or below
Withstand voltage:	1500 VAC
Insulation resistance:	500 VDC 10 M Ω min.
Enclosure:	Totally enclosed, self-cooled
Ambient temperature:	0 to 40°C
Ambient humidity:	20% to 80% (non-condensing)
Excitation:	Permanent magnet
Drive method:	Direct drive
Mounting:	Flange method

Table 6.8 Ratings and Specifications of SGM Model

Servomotor SGM-		02A	04A	08A
Rated Output* ¹	W (HP)	200 (0.272)	400 (0.536)	750 (1.006)
Rated Torque * ¹ * ²	N·m	0.637	1.27	2.39
	kgf·cm (lb·in)	6.49 (5.64)	13.0 (11.2)	24.3 (21.2)
Instantaneous Peak Torque* ¹	N·m	1.91	3.82	7.1
	kgf·cm (lb·in)	19.5 (16.9)	39.0 (33.8)	72.9 (62.8)
Rated Current* ¹	A (rms)	2.0	2.6	4.4
Instantaneous Max Current* ¹	A (rms)	6.0	8.0	13.9
Rated Speed* ¹	min ⁻¹	3000		
Instantaneous Max Speed* ¹	min ⁻¹	4500		
Torque Constant* ¹	N·m/A (rms)	0.355	0.533	0.590
	kgf·cm/A (lb·in/A)(rms)	3.62 (3.14)	5.44 (4.72)	6.01 (5.22)
Moment of Inertia [J_M]	(= $GD_M^2/4$) kg·m ² × 10 ⁻⁴	0.123	0.191	0.671
	gf·cm·s ² (oz·in·s ² × 10 ⁻³)	0.126 (1.74)	0.195 (2.70)	0.685 (9.50)
Rated Power Rate* ¹	kW/s	32.8	84.6	85.1
Rated Angular Acceleration* ¹	rad/s ²	51800	66600	35600
Inertia Time Constant	ms	0.4	0.3	0.3
Inductive Time Constant	ms	5.4	6.4	13

* 1. These items and torque-speed characteristics are the values obtained in combination with an SGDB SERVOPACK with the armature winding temperature at 100°C; other values were obtained with the armature winding temperature at 20°C. Note also that all values are representative values only.

* 2. Rated torque indicates the continuous allowable torque at an ambient temperature of 40°C when attached to a heat sink measuring 250 × 250 × 6 mm (9.84 × 9.84 × 0.24 in).

IMPORTANT

The ratings and specifications on the previous page are for a standard Servomotor.

Add the numeric values to the moment of inertia values in the *Table 6.8* for a motor fitted with a holding brake and a 12-bit absolute encoder. Other specifications will also change slightly.

SGM-		0.2A	04A	08A
With Holding Brake	$\text{kg}\cdot\text{m}^2 \times 10^{-4}$	0.058		0.14
	$\text{gf}\cdot\text{cm}\cdot\text{s}^2$ ($\text{lb}\cdot\text{in}\cdot\text{s}^2 \times 10^{-3}$)	0.059 (0.051)		0.143 (0.124)
With 12-bit Absolute Encoder	$\text{kg}\cdot\text{m}^2 \times 10^{-4}$	0.025		
	$\text{gf}\cdot\text{cm}\cdot\text{s}^2$ ($\text{lb}\cdot\text{in}\cdot\text{s}^2 \times 10^{-3}$)	0.026 (0.022)		

Also, if an oil seal is attached, use the reduced rating shown below. This is required for the resulting increase in friction torque. In this case, too, the values of other specifications will also change slightly.

SGM-	02A	04A	08A
Reduced rate (%)	90	95	

6



◆ Holding Brake

The holding brake is automatically applied to the motor shaft to prevent the load falling in vertical axis applications when the motor power supply is turned OFF or fails. It is only to hold the load and cannot be used to stop the motor.

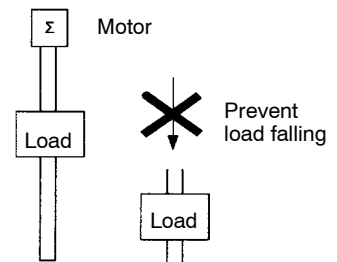

The electrical specifications and static friction torque of the holding brake are shown below.

SGM (Rated Voltage: 90 VDC): Standard Models

Motor Model	Motor Capacity W (HP)	Holding Brake Specifications			
		Capacity W (HP)	Holding Torque N•m (lb•in)	Coil Resistance Ω at 20°C	Rated Current A at 20°C
SGM-02□□□□	200 (0.272)	6.5 (0.009)	1.47 (13.0)	1246	0.072
SGM-04□□□□	400 (0.536)	6.5 (0.009)	1.47 (13.0)	1246	0.072
SGM-08□□□□	750 (1.006)	6 (0.008)	2.45 (21.7)	1350	0.067

SGM (Rated Voltage: 24 VDC): Nonstandard Models

Motor Model	Motor Capacity W (HP)	Holding Brake Specifications			
		Capacity W (HP)	Holding Torque N•m (lb•in)	Coil Resistance Ω at 20°C	Rated Current A at 20°C
SGM-02□□□□	200 (0.272)	6.5 (0.009)	1.47 (13.0)	89	0.27
SGM-04□□□□	400 (0.536)	6.5 (0.009)	1.47 (13.0)	89	0.27
SGM-08□□□□	750 (1.006)	6 (0.008)	2.45 (21.7)	96	0.25

SGM Torque-Speed Characteristics

SGM-02A

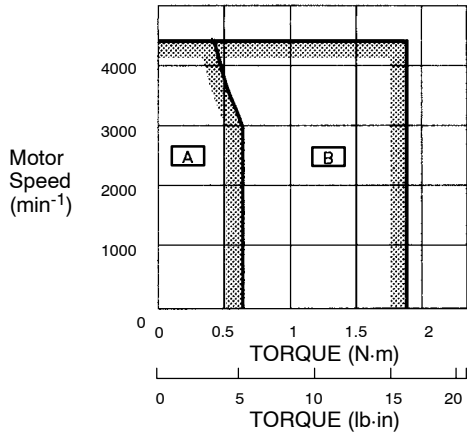

SGM-04A

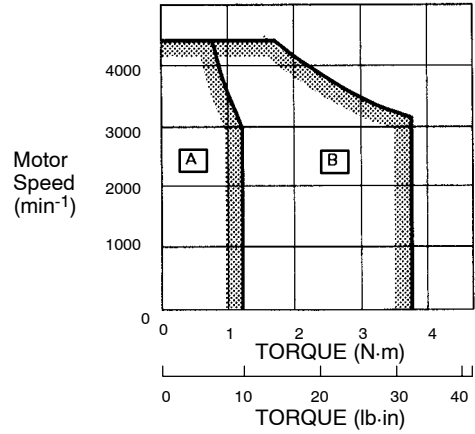

SGM-08A

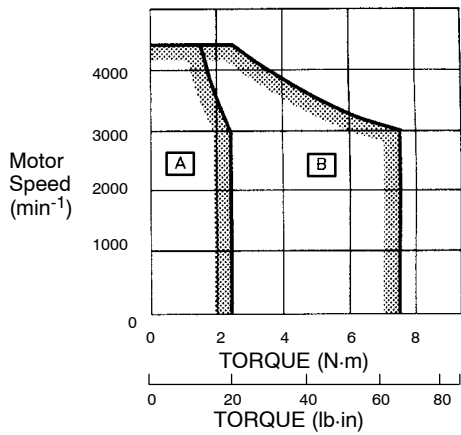

A: Continuous Duty Zone
 B: Intermittent Duty Zone

6.2.2 Mechanical Characteristics

This section describes the mechanical characteristics of Servomotors.

■ Allowable Radial Load, Allowable Thrust Load

The output shaft allowable loads for SGM□ Servomotor are shown below.

Perform mechanical design such that the thrust loads and radial loads do not exceed the values stated below.

Table 6.9 Allowable Radial Load and Thrust Load of Servomotor

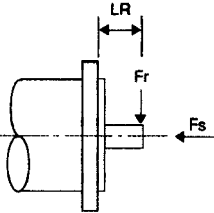
Servomotor Model	Allowable Radial Load F_r [N(lb)]	Allowable Thrust Load F_s [N(lb)]	LR mm (in.)	Reference Diagram
SGMG-05A□A	490 (110)	98 (22)	58 (2.28)	
-09A□A	490 (110)	98 (22)		
-13A□A	686 (154)	343 (77)		
-20A□A	1176 (265)	490 (110)	79 (3.11)	
-30A□A	1470 (331)	490 (110)		
-44A□A	1470 (331)	490 (110)		
-55A□A	1764 (397)	588 (132)	113 (4.45)	
-75A□A	1764 (397)	588 (132)		
-1AA□A	1764 (397)	588 (132)	116 (4.57)	
	4998 (1125)	2156 (485)		
SGMG-03A□B	490 (110)	98 (22)	58 (2.28)	
-06A□B	490 (110)	98 (22)		
-09A□B	686 (154)	343 (77)		
-12A□B	1176 (265)	490 (110)	79 (3.11)	
-20A□B	1470 (331)	490 (110)		
-30A□B	1470 (331)	490 (110)		
-44A□B	1764 (397)	588 (132)	113 (4.45)	
-60A□B	1764 (397)	588 (132)		

Servomotor Model	Allowable Radial Load Fr [N(lb)]	Allowable Thrust Load Fs [N(lb)]	LR mm (in.)	Reference Diagram
SGMS-10A	686 (154)	196 (44)	45 (1.77)	
-15A	686 (154)	196 (44)		
-20A	686 (154)	196 (44)		
-30A	980 (221)	392 (88)	63 (2.48)	
-44A	1176 (265)	392 (88)		
-50A	1176 (265)	392 (88)		
SGMD-22A	1176 (265)	490 (110)	55 (2.17)	
-32A	1176 (265)	490 (110)		
-40A	1176 (265)	490 (110)	65 (2.56)	
SGM-04A	245 (55)	74 (17)	25 (0.98)	
-08A	392 (88)	147 (33)	35 (1.38)	
SGMP-04A	245 (55)	68 (15)	25 (0.98)	
-08A	392 (88)	147 (33)	35 (1.38)	
-15A	490 (110)	147 (33)		

* Allowable radial loads shown above are the maximum values that could be applied to the shaft end.

■ Mechanical Tolerance

The tolerances of the SGM□ Servomotor output shaft and installation are shown in the table below.

Tolerance (T.I.R.)	Tolerance (T.I.R.)	Reference Diagram
Perpendicularity between flange face and output shaft (A)	0.04mm (0.0016in.)	
Mating concentricity of flange O.D. (B)	0.04mm (0.0016in.)	
Run-out at end of shaft (C)	0.02mm (0.00079in.)	

■ Direction of Motor Rotation

Positive rotation of the servomotor is counterclockwise, viewing from the drive end.

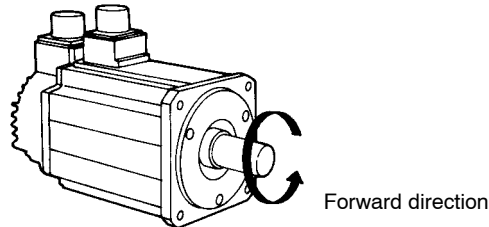

■ Impact Resistance

Mount the servomotor with the axis horizontal. The servomotor must withstand the following vertical impacts.

SGM, SGMP

- Impact Acceleration: 98 m/s^2 (10 G)
- Number of Impacts: 2

SGMG, SGMS, SGMD

- Impact Acceleration: 490 m/s^2 (50 G)
- Number of Impacts: 2

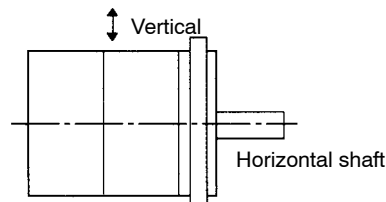

Impact Applied to Servomotor

IMPORTANT

In SGM□ Servomotors, an accurate detector is attached to the shaft at the opposite end from the load. Avoid applying impacts directly to the shaft as these may damage the detector.

■ Vibration Resistance

Mount the servomotor with the axis horizontal. The servomotor must withstand the following vibration accelerations in three directions: vertical, transverse, and longitudinal.

- Vibration Acceleration: 24.5 m/s^2 (2.5 G)

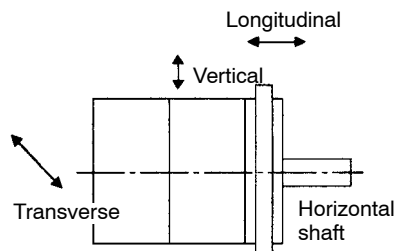

Vibration Applied to Servomotor

■ Vibration Class

The SGM□ Servomotors meet the following vibration class at rated speed.

- Vibration Class: 15 μm or below

Vibration Measurement Position

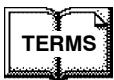
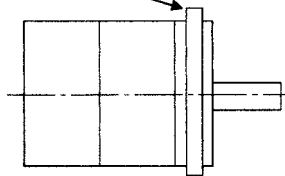

◆ Vibration Class

Vibration class 15 μm or below indicates that the total amplitude of vibration of the motor alone, running at rated speed, does not exceed 15 μm .

6.3 SERVOPACK Ratings and Specifications

This section presents tables of SGDB SERVOPACK ratings and specifications.

6.3.1 Combined Specifications

The following table shows the specifications obtained when SGDB SERVOPACKs are combined with SGMG, SGMS, SGMD, SGM, and SGMP Servomotors:

Table 6.10 Combined Specifications of SERVOPACKs and Servomotors

SGMG Series	SERVOPACK SGDB-		05AM	10AM	10AM	15AM	20AM	30AM	50AM	60AM
	Motor	Model SGMG-	03A□B	06A□B	09A□B	12A□B	20A□B	30A□B	44A□B	60A□B
	Capacity kW (HP)	0.3 (0.4)	0.6 (0.8)	0.9 (1.2)	1.2 (1.6)	2.0 (2.7)	3.0 (4.0)	4.4 (5.9)	6.0 (8.0)	
	Rated/Max. Motor Speed min ⁻¹	1000/2000								
Applicable Encoder		Standard: Incremental encoder (8192 P/R)								
	Continuous Output Current A (rms)	3.0	5.7	7.6	11.6	18.5	24.8	32.9	46.9	
	Max. Output Current A (rms)	7.3	13.9	16.6	28	42	56	84	110	
	Allowable Load Inertia* J_L kg·m ² ×10 ⁻⁴ (lb·in·s ² ×10 ⁻³)	36.2 (32.0)	69.5 (61.5)	103 (91.2)	159 (141)	230 (204)	338 (299)	445 (394)	625 (553)	

Servo Selection and Data Sheets

6.3.1 Combined Specifications

SGMG Series		SERVOPACK SGDB-	05AM	10AM	15AM	20AM	30AM	50AM	60AM	75AM	1AAM	1EAM
Motor	Model SGMG-	05 A□A	09 A□A	13 A□A	20 A□A	30 A□A	44 A□A	55 A□A	75 A□A	1A A□A	1E A□A	
	Capacity kW (HP)	0.45 (0.6)	0.85 (1.1)	1.3 (1.7)	1.8 (2.4)	2.9 (3.9)	4.4 (5.9)	5.5 (7.4)	7.5 (10)	11 (15)	15 (20)	
	Rated/Max. Motor Speed min ⁻¹	1500/3000									1500/2000	
Applicable Encoder		Standard: Incremental encoder (8192 P/R)										
	Continuous Output Current A (rms)	3.8	7.1	10.7	16.7	23.8	32.8	42.1	54.7	58.6	78.6	
	Max. Output Current A (rms)	11	17	28	42	56	84	110	130	140	170	
	Allowable Load Inertia* J_L kg·m ² ×10 ⁻⁴ (lb·in·s ² ×10 ⁻³)	36.2 (32.0)	69.5 (61.5)	103 (91.2)	159 (141)	230 (204)	338 (299)	445 (394)	625 (553)	1405 (1244)	1575 (1394)	
SGMD Series		SERVOPACK SGDB-						30AM	50AM	50AM		
Motor	Model SGMD-							22 A□A	32 A□A	40 A□A		
	Capacity kW (HP)							2.2 (2.9)	3.2 (4.3)	4.0 (5.4)		
	Rated/Max. Motor Speed min ⁻¹	2000/3000										
Applicable Encoder		Standard: Absolute encoder (1024 P/R)										
	Continuous Output Current A (rms)							15.7	20.9	22.8		
	Max. Output Current A (rms)							54	73	77		
	Allowable Load Inertia* J_L kg·m ² ×10 ⁻⁴ (lb·in·s ² ×10 ⁻³)							255 (226)	343 (304)	431 (382)		

* The allowable load inertia is five times the motor inertia for the SGMG and the SGMD.

SGMS Series	SERVOPACK SGDB-		10AM	15AM	20AM	30AM	50AM	50AM					
	Motor	Model		10 A□A	15 A□A	20 A□A	30 A□A	40 A□A	50 A□A				
	SGMS-												
	Capacity		1.0 (1.3)	1.5 (2.0)	2.0 (2.7)	3.0 (4.0)	4.0 (5.4)	5.0 (6.7)					
	kW (HP)												
	Rated/Max. Motor Speed	3000/4500											
	min ⁻¹												
	Applicable Encoder	Standard: Incremental encoder (4096 P/R)											
	Continuous Output Current		5.7	9.5	12.4	18.8	24.3	28.2					
	A (rms)												
	Max. Output Current		17	28	42	56	77	84					
	A (rms)												
	Allowable Load Inertia*J _L		8.7 (7.7)	12.4 (11.0)	16.0 (14.2)	35.0 (31.0)	48.0 (42.5)	61.5 (54.5)					
	kg·m ² ×10 ⁻⁴ (lb·in·s ² ×10 ⁻³)												
SGMP Series	SERVOPACK SGDB-		02AM	05AM	10AM	15AM							
	Motor	Model	02A□	04A□	08A□	15A□							
	SGMP-												
	Capacity	0.2 (0.3)	0.4 (0.5)	0.75 (1.0)	1.5 (2.0)								
	kW (HP)												
	Rated/Max. Motor Speed	3000/4500											
	min ⁻¹												
	Applicable Encoder	Standard: Incremental encoder (2048 P/R)											
	Continuous Output Current	2.0	2.6	4.1	7.5								
	A (rms)												
	Max. Output Current	6.0	8.0	13.9	23.0								
	A (rms)												
	Allowable Load Inertia*J _L	6.27 (5.55)	10.4 (9.20)	10.6 (9.38)	20.2 (17.9)								
	kg·m ² ×10 ⁻⁴ (lb·in·s ² ×10 ⁻³)												
SGM Series	SERVOPACK SGDB-		02AM	05AM	10AM								
	Motor	Model	02A□	04A□	08A□								
	SGM-												
	Capacity	0.2 (0.3)	0.4 (0.5)	0.75 (1.0)									
	kW (HP)												
	Rated/Max. Motor Speed	3000/4500											
	min ⁻¹												
	Applicable Encoder	Standard: Incremental encoder (2048 P/R)											
	Continuous Output Current	2.0	2.6	4.4									
	A (rms)												
	Max. Output Current	6.0	8.0	13.9									
	A (rms)												
	Allowable Load Inertia*J _L	3.69 (3.27)	5.73 (5.07)	20.1 (17.8)									
	kg·m ² ×10 ⁻⁴ (lb·in·s ² ×10 ⁻³)												

* The allowable load inertia is five times the motor inertia for the SGMS, SGMP, and SGM.

6.3.2 Ratings and Specifications

The ratings and specifications of SERVOPACKs are shown in *Table 6.11* below. Refer to them when selecting a SERVOPACK.

Table 6.11 Ratings and Specifications of SERVOPACKs

SERVOPACK SGDB-		02	05	10	15	20	30	50	60	75	1A	1E	
Applicable Servomotor	SGMG- (1500 min ⁻¹)	-	05A	09A	13A	20A	30A	44A	55A	75A	1AA	1EA	
	SGMG- (1000 min ⁻¹)	-	03A	06A, 09A	12A	20A	30A	44A	60A	-	-	-	
	SGMS-	-	-	10A	15A	20A	30A	40A, 50A	-	-	-	-	
	SGMD-	-	-	-	-	-	22A	32A, 40A	-	-	-	-	
	SGMP-	02A	04A	08A	15A	-	-	-	-	-	-	-	
	SGM-	02A	04A	08A	-	-	-	-	-	-	-	-	
Basic Specifications	Input Power Supply	Main Circuit* ¹	Three-phase 200 to 230 VAC +10% to -15%, 50/60 Hz										
		Control Circuit* ¹	Single-phase 200 to 230 VAC +10% to -15%, 50/60 Hz										
	Control Mode		Three-phase, full-wave rectification IGBT PWM (sine-wave driven)										
	Feedback		Incremental encoder, absolute encoder										
	Location	Operating/Storage Temperature* ²		0 to 55°C/-20 to 85°C									
		Operating and Storage Humidity		90% or less (non-condensing)									
		Vibration/Shock Resistance		4.9 m/s ² /19.6 m/s ²									
	Structure		Base-mounted (duct ventilation available as option)										
Approx. Mass 1 (lb)		4 (9)				5 (11)			15 (33)		23 (51)		

6

SERVOPACK SGDB-			02	05	10	15	20	30	50	60	75	1A	1E
Position Control Function	Station Number Command Method	Operating Specifications	Fixed point positioning using station numbers (contact data)										
		Command Input	Position command: BCD (000 to 999) or binary number (0 to 4095, 12 bits)										
		System	Absolute command or incremental command										
	Digital Switch Command Method	Operating Specifications	Positioning by digital switches										
		Command Input	Position command: Sign + 8 digits max. (-99999999 to +99999999) Speed command: 6 digits max. (000001 to 240000), but must not exceed maximum rotation speed of motor										
		System	Absolute command or incremental command										
	Serial Communications Command Method	Operating Specifications	Positioning by serial communications										
		Command Input	Asynchronous, baud rate 1200 to 38400 bps (Initial setting: 38400 bps)										
		System	Absolute command or incremental command										
	Command Table Method	Operating Specifications	Positioning by position and speed number command (contact data)										
		Command Input	Position command: Position table, sign + 8 bits max. (-99999999 to +99999999) Speed command: Speed table, 6 digits max. (000001 to 240000), but must not exceed maximum rotation speed of motor Position and speed number command: Binary number (1 to 512, 9 bits max.)										
		System	Absolute command or incremental command										
	Pulse Mode	Operating Specifications	Positioning by pulse train (line PG or pulse train input)										
		Command Input	Position: Pulse number 90° phase difference 2-phase pulse train, forward + reverse pulse train, sign + pulse train Speed: Pulse frequency 450 kpps max. Form: Line driver (+5 V)										
		System	Compatible with incremental command only										
Performance	Bias Setting		0 to 450 min ⁻¹ (setting resolution: 1 min ⁻¹)										
	Feed-forward Compensation		0 to 100% (setting resolution: 1%)										
	Positioning Completed Width Setting		0 to 250 command units (setting resolution: 1 command unit)										

SERVOPACK SGDB-			02	05	10	15	20	30	50	60	75	1A	1E
I/O Functions	Position Output	Output Form	Line driver output: Phases A and B										
		Frequency Dividing Ratio	16 to 32768 (up to number of encoder pulses)										
	Control Interface I/O	Input	1 serial port, 24 V digital system										
		Output	1 serial port, 24 V system and 5 V system (PG division output)										
	Analog Monitor Output	CH1	Speed feedback: 2 V/1000 min ⁻¹ or 1 V/1000 min ⁻¹										
			Position error: 0.05 V/command units or 0.05 V/100 command units										
		CH2	Torque command: 2 V/rated torque										
Speed command: 2 V/1000 min ⁻¹ or 1 V/1000 min ⁻¹													
Built-in Functions	Dynamic Brake (DB)		Activated at main power OFF, alarm, servo OFF or overtravel (specified by parameter).										
	Regenerative Processing		Built-in. (For 5 kW or greater, an external regenerative resistor must be mounted.)										
	Overtravel (OT) Prevention		When P-OT or N-OT is activated, the motor is stopped by dynamic brake, decelerates to a stop, or coasts to a stop (specified by parameter).										
	External Current Limit		Switches between forward (Cn-08) and reverse (Cn-09) current limits in accordance with /P-CL or /N-CL contact input; or a fixed current limit specified by parameter (Cn-10).										
	Protection		Absolute data alarm (A.00), parameter breakdown (A.02), parameter setting alarm (A.04), overcurrent (A.10), regenerative alarm (A.30), main circuit voltage alarm (A.40), overspeed (A.51), overload (A.71 and A.72), heat sink overheat (A.7A), zero point alarm (A.80), absolute PG back-up alarm (A.81), absolute PG checksum alarm (A.82), absolute PG battery alarm or SERVOPACK battery alarm (A.83), absolute PG data alarm (A.84), absolute PG overspeed (A.85), Servo overrun (A.C1), PG phase error detection (A.C2), PG phase A or phase B disconnection (A.C3), PG phase C disconnection (A.C4), position error pulse overflow (A.D0), hardware alarm (A.B0), CPU error (A.B2 and A.B3), power line open phase detect (A.F1), power loss (A.F3). Note: Occasionally hardware errors may not be included in alarm trace-back, and CPU errors may occasionally be included in alarm trace-back but not displayed.										
	Display		POWER (control power supply), ALARM (alarm), CHARGE (main circuit capacitor charging), STATUS (7-segment LED status display)										
	Monitor		Serial communications, digital operator (position, speed, torque, I/O signals, etc.), analog voltage (current speed, torque command, speed command, position error)										

6

SERVOPACK SGDB-		02	05	10	15	20	30	50	60	75	1A	1E	
Built-in Functions	Position Control Functions	Linear acceleration/deceleration (1-step and 2-step), exponential acceleration/deceleration, S-curve acceleration/deceleration, electronic gear function, command pulse multiplication, stored stroke limit, backlash compensation, COIN (positioning complete output), NEAR (positioning near output), line PG switching, etc.											
	Absolute Encoder Back-up	Battery mounted on SERVOPACK panel; contains built-in super capacitor											
	Communications	Interface	RS-422A port of personal computer, etc. (RS-232C port can be used if certain conditions are met.) Digital Operator (JUSP-OP02A-1, JUSP-OP03A)										
		Number of Communications Axes	15 axes if group configuration is not specified; 32 axes if group configuration is specified (when connected via RS-422A port).										
		Axis Address Setting	Hexadecimal rotary switch (1 SW); group setting is specified by parameter (Cn-13).										
Functions		Operation command input, status display, parameter settings, table settings, monitor display, alarm trace-back display, etc.											

* 1. The SERVOPACK cannot be used if the power supply voltage exceeds $230\text{ V} + 10\%$ (253 V). If it is likely to exceed this limit, use a step-down transformer.

* 2. Install the SERVOPACK where the ambient temperature lies within this range. Even if the SERVOPACK is installed in a box, the temperature within the box must not exceed this range.

6.3.3 Overload Characteristics

The SERVOPACK has a built-in overload protective function to protect the SERVOPACK and Servomotor from overload. Therefore, the SERVOPACK allowable power is limited by the overload protective function, as shown below.

The overload detection level is quoted under hot start conditions at a motor ambient temperature of 40°C.

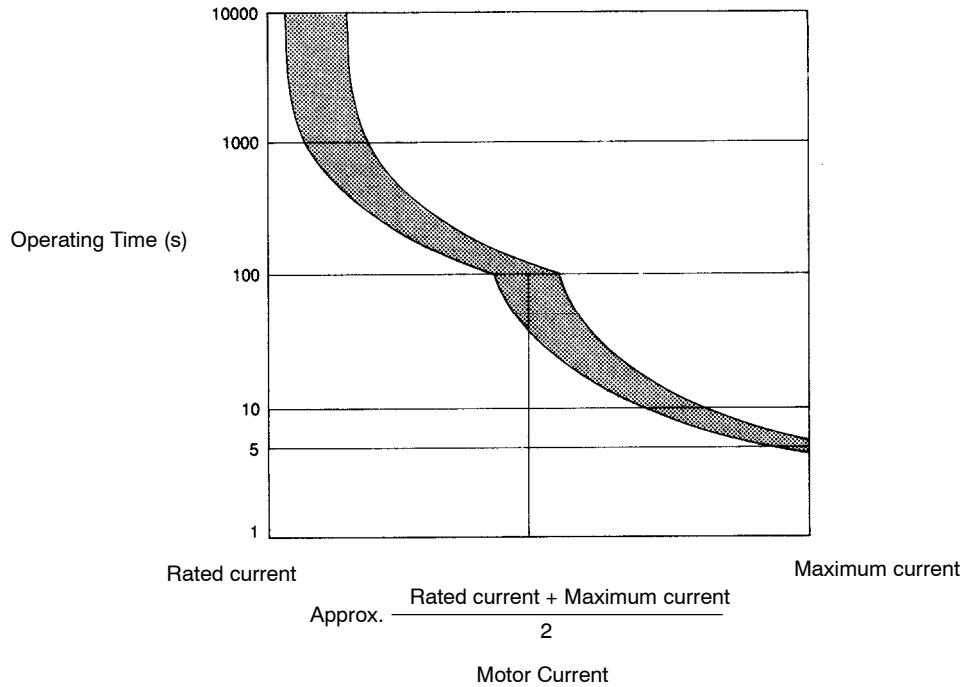

Figure 6.5 Overload Characteristics



◆ Hot Start

Indicates that both SERVOPACK and Servomotor have run long enough at rated load to be thermally saturated and then can be restarted while hot.

6.3.4 Starting Time and Stopping Time

The motor starting time (t_r) and stopping time (t_f) under constant load are calculated by the following formulas. The motor viscous torque and friction torque are ignored.

$$\text{Starting Time: } t_r = \frac{2\pi \cdot N_m (J_M + J_L)}{60 \cdot (T_{PM} - T_L)} \quad [\text{s}]$$

$$\text{Stopping Time: } t_f = \frac{2\pi \cdot N_m (J_M + J_L)}{60 \cdot (T_{PM} + T_L)} \quad [\text{ms}]$$

N_M : Motor speed used (min^{-1})

J_M : Motor moment of inertia ($\text{kg}\cdot\text{m}^2$) ($\text{GD}_M^2/4$)

J_L : Load converted to shaft moment of inertia ($\text{kg}\cdot\text{m}^2$) ($\text{GD}_L^2/4$)

T_{PM} : Maximum instantaneous motor torque obtained in combination with SERVOPACK ($\text{N}\cdot\text{m}$)

T_L : Load torque ($\text{N}\cdot\text{m}$)

To convert the motor current value into an equivalent torque value, use the following formula:

Motor torque constant \times motor current value (effective value)

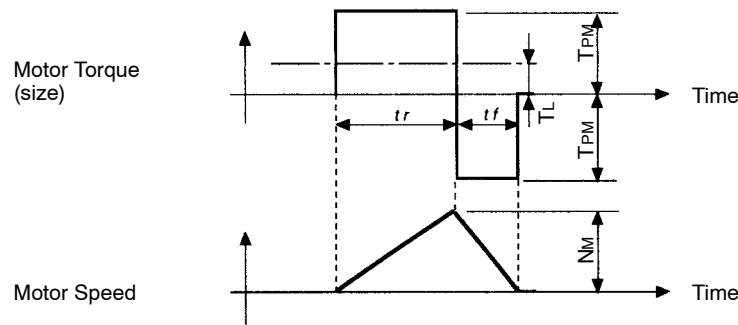

Figure 6.4 Motor Torque (Size) - Motor Speed Timing Chart

6.3.5 Load Inertia

The larger the load inertia becomes, the worse the movement response of the load. The size of the load inertia (J_L) allowable when using a servomotor must not exceed five times the motor inertia (J_M).

For the SGM-04A□, SGM-08A□, and SGMP-04A□, this limitation is 30 times the motor inertia, and for the SGMP-08A□, it is 10 times the motor inertia.

If the load inertia exceeds five times the motor inertia, an overvoltage alarm may arise during deceleration. To prevent this, take one of the following actions:

- Reduce the torque limit value.
- Reduce the slope of the deceleration curve.
- Reduce the maximum motor speed.
- Consult your Yaskawa representative.

6.3.6 Overhanging Loads

A Servomotor may not be operated under an overhanging load, which is a load which tends to continually rotate the motor. The following figure shows a typical example of overhanging load.

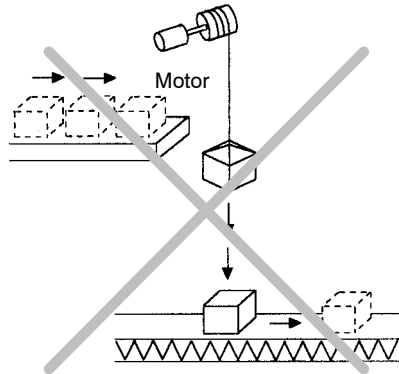

Motor drive for vertical axis, using no counterweight

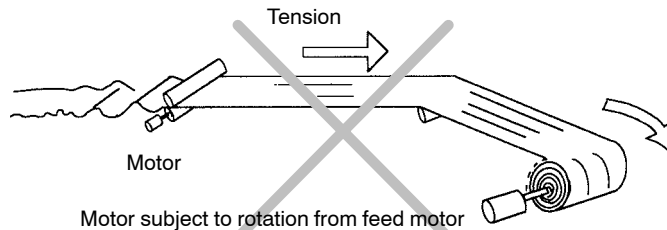

Motor subject to rotation from feed motor to maintain applied tension.

Tension control drive

Figure 6.5 Typical Example of Overhanging Load

IMPORTANT

Under an overhanging load, SERVOPACK regenerative brake is continuously applied, and the regenerative energy of the load may exceed the allowable range and damage the SERVOPACK. The regenerative brake capacity of the SERVOPACK is rated for short-time operation, approximately equivalent to the deceleration stopping time.

6.4 Σ-Series Dimensional Drawings

This section presents dimensional drawings of the Σ-Series Servomotor, SERVOPACK, and Digital Operator.

6.4.1 Servomotor Dimensional Drawings

The dimensional drawings of the SGMG, SGMS, SGMD and SGMP (1.5 kW) Servomotors are shown on the following pages. Note that the models and dimensional drawings of the SGMG Servomotors differ according to rated speed (1500 or 1000 min⁻¹).

The dimensional drawings of each Servomotor series are broadly divided into four types, according to the detector type (incremental or absolute encoder) and the presence or absence of a brake.

Model	Reference Pages
SGMG Servomotors, 1500 min ⁻¹	Page 6 -55 to 6 -69
SGMG Servomotors, 1000 min ⁻¹	Page 6 -69 to 6 -81
SGMS Servomotors	Page 6 -81 to 6 -89
SGMD Servomotors	Page 6 -90 to 6 -94
SGM Servomotors	Page 6 -95 to 6 -106
SGMP Servomotors	Page 6 -107 to 6 -126

■ SGMG-□□A□A Servomotors (1500 min⁻¹)

With Incremental Encoder (8192 P/R)

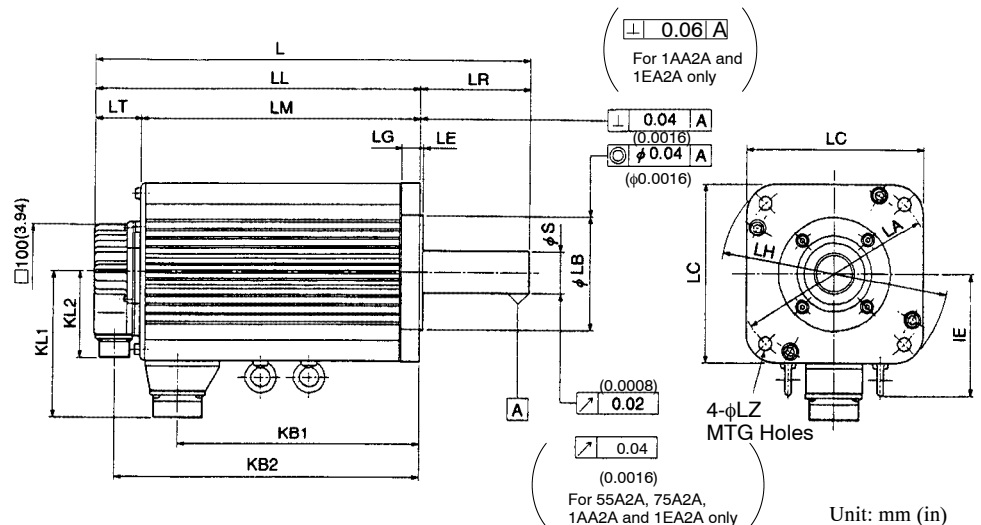

Detailed View of Shaft End

SGMG-05A2A to -13A2A, -1AA2A and -1EA2A

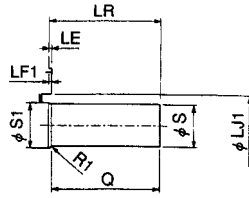

SGMG-20A2A to -75A2A

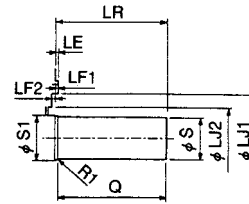

Unit: mm (in)

Model SGMG-	L	LL	LM	LR	LT	KB1	KB2	IE	KL1	KL2
05A2A	196 (7.72)	138 (5.43)	92 (3.62)	58 (2.28)	46 (1.81)	65 (2.56)	117 (4.61)	-	109 (4.29)	88 (3.46)
09A2A	219 (8.62)	161 (6.34)	115 (4.53)	58 (2.28)	46 (1.81)	88 (3.46)	140 (5.51)	-	109 (4.29)	88 (3.46)
13A2A	243 (9.57)	185 (7.28)	139 (5.47)	58 (2.28)	46 (1.81)	112 (4.41)	164 (6.46)	-	109 (4.29)	88 (3.46)
20A2A	245 (9.65)	166 (6.54)	119 (4.69)	79 (3.11)	47 (1.85)	89 (3.50)	145 (5.71)	-	140 (5.51)	88 (3.46)
30A2A	271 (10.67)	192 (7.56)	145 (5.71)	79 (3.11)	47 (1.85)	115 (4.53)	171 (6.73)	-	140 (5.51)	88 (3.46)
44A2A	305 (12.01)	226 (8.90)	179 (7.05)	79 (3.11)	47 (1.85)	149 (5.87)	205 (8.07)	-	140 (5.51)	88 (3.46)
55A2A	373 (14.69)	260 (10.24)	213 (8.39)	113 (4.45)	47 (1.85)	174 (6.85)	239 (9.41)	125 (4.92)	150 (5.91)	88 (3.46)
75A2A	447 (17.60)	334 (13.15)	287 (11.30)	113 (4.45)	47 (1.85)	248 (9.76)	313 (12.32)	125 (4.92)	150 (5.91)	88 (3.46)
1AA2A	454 (17.87)	338 (13.31)	291 (11.46)	116 (4.57)	47 (1.85)	251 (9.88)	317 (12.48)	142 (5.59)	168 (6.61)	88 (3.46)
1EA2A	573 (22.56)	457 (17.99)	388 (15.28)	116 (4.57)	69 (2.72)	343 (13.50)	435 (17.13)	142 (5.59)	168 (6.61)	88 (3.46)

Unit: mm (in)

Model SGMG-	Flange Dimensions											Shaft End Dimensions			Approx. Mass kg (lb)
	LA	LB	LC	LE	LF1	LF2	LG	LH	LJ1	LJ2	LZ	S	S1	Q	
05A2A	145 (5.71)	$110 - 0.035$ 0 (4.33 - 0.0014)	130 (5.12)	6 (0.24)	6 (0.24)	–	12 (0.47)	165 (6.50)	45 (1.77)	–	9 (0.35)	$19 - 0.013$ 0 (0.75 - 0.0005)	30 (1.18)	40 (1.57)	5.5 (12.12)
09A2A	145 (5.71)	$110 - 0.035$ 0 (4.33 - 0.0014)	130 (5.12)	6 (0.24)	6 (0.24)	–	12 (0.47)	165 (6.50)	45 (1.77)	–	9 (0.35)	$19 - 0.013$ 0 (0.75 - 0.0005)	30 (1.18)	40 (1.57)	7.6 (16.75)
13A2A	145 (5.71)	$110 - 0.035$ 0 (4.33 - 0.0014)	130 (5.12)	6 (0.24)	6 (0.24)	–	12 (0.47)	165 (6.50)	45 (1.77)	–	9 (0.35)	$22 - 0.013$ 0 (0.87 - 0.0005)	30 (1.18)	40 (1.57)	9.6 (21.16)
20A2A	200 (7.87)	$114.3 - 0.025$ 0 (4.50 - 0.0010)	180 (7.09)	3.2 (0.13)	3 (0.12)	0.5 (0.0197)	18 (0.71)	230 (9.06)	76 (2.99)	62 (2.44)	13.5 (0.53)	$35 + 0.01$ 0 (1.38 + 0.0004)	45 (1.77)	76 (2.99)	14 (30.86)
30A2A	200 (7.87)	$114.3 - 0.025$ 0 (4.50 - 0.0010)	180 (7.09)	3.2 (0.13)	3 (0.12)	0.5 (0.0197)	18 (0.71)	230 (9.06)	76 (2.99)	62 (2.44)	13.5 (0.53)	$35 + 0.01$ 0 (1.38 + 0.0004)	45 (1.77)	76 (2.99)	18 (39.68)
44A2A	200 (7.87)	$114.3 - 0.025$ 0 (4.50 - 0.0010)	180 (7.09)	3.2 (0.13)	3 (0.12)	0.5 (0.0197)	18 (0.71)	230 (9.06)	76 (2.99)	62 (2.44)	13.5 (0.53)	$35 + 0.01$ 0 (1.38 + 0.0004)	45 (1.77)	76 (2.99)	23 (50.69)
55A2A	200 (7.87)	$114.3 - 0.025$ 0 (4.50 - 0.0010)	180 (7.09)	3.2 (0.13)	3 (0.12)	0.5 (0.0197)	18 (0.71)	230 (9.06)	76 (2.99)	62 (2.44)	13.5 (0.53)	$42 - 0.016$ 0 (1.65 - 0.0006)	45 (1.77)	110 (4.33)	30 (66.13)
75A2A	200 (7.87)	$114.3 - 0.025$ 0 (4.50 - 0.0010)	180 (7.09)	3.2 (0.13)	3 (0.12)	0.5 (0.0197)	18 (0.71)	230 (9.06)	76 (2.99)	62 (2.44)	13.5 (0.53)	$42 - 0.016$ 0 (1.65 - 0.0006)	45 (1.77)	110 (4.33)	40 (88.18)
1AA2A	235 (9.25)	$200 - 0.046$ 0 (7.87 - 0.0018)	220 (8.66)	4 (0.16)	4 (0.16)	–	18 (0.71)	270 (10.63)	62 (2.44)	–	13.5 (0.53)	$42 - 0.016$ 0 (1.65 - 0.0006)	45 (1.77)	110 (4.33)	57.5 (126.73)
1EA2A	235 (9.25)	$200 - 0.046$ 0 (7.87 - 0.0018)	220 (8.66)	4 (0.16)	4 (0.16)	–	20 (0.79)	270 (10.63)	85 (3.35)	–	13.5 (0.53)	$55 + 0.030$ $+ 0.011$ $(2.17 + 0.0004)$	65 (2.56)	110 (4.33)	86 (189.6)

Note: 1. An incremental encoder (8192 P/R) is used as a detector.

2. SGMG-05A to -44A2A do not contain eyebolts.

● Connector Wiring on Detector End

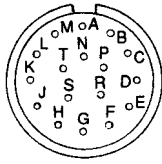

Receptacle: MS3102A20-29-P
 Plug (To be prepared by customer) (L type): MS3108B20-29S or (Straight type) MS3057-12A
 Cable Clamp: (To be prepared by customer) MS3057-12A

A	A channel output	K	---
B	\bar{A} channel output	L	---
C	B channel output	M	---
D	\bar{B} channel output	N	---
E	C channel output	P	---
F	\bar{C} channel output	R	---
G	0 V	S	---
H	+5 VDC	T	---
J	FG (Frame Ground)		

- Note: 1. Terminals K to T are not used.
 2. Receptacle, plug and cable clamp are common regardless of motor capacity.

● Connector Wiring on Motor End

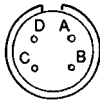

A	Phase U
B	Phase V
C	Phase W
D	Ground terminal

Note: Receptacle, plug and cable clamp differ depending on the capacity. Refer to *Connectors on Detector and Motor Ends* (page 6-127).

With Incremental Encoder (8192 P/R) and Brake

- 0.5 to 4.4 kW

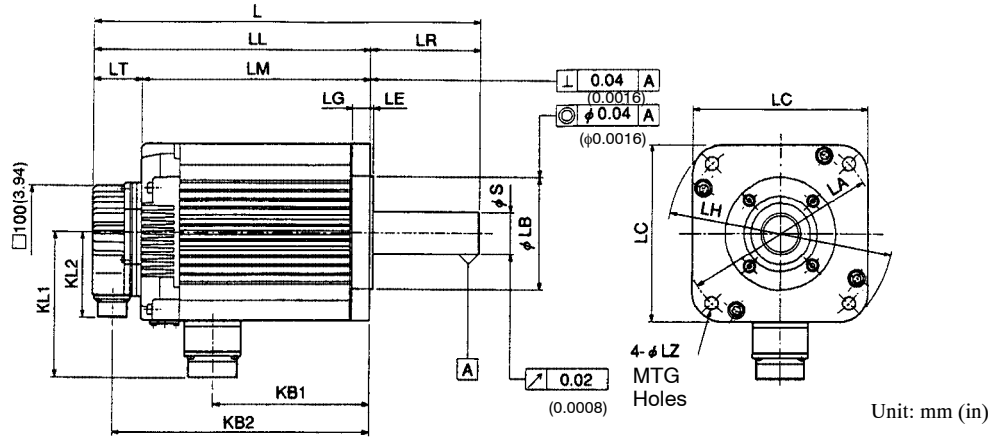

Detailed View of Shaft End

SGMG-05A2AAB to -13A2AAB

SGMG-20A2AAB to -44A2AAB

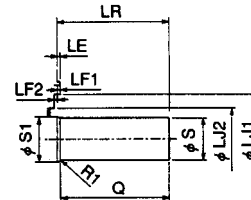
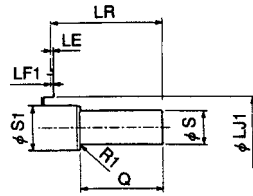

Unit: mm (in)

Model SGMG-	L	LL	LM	LR	LT	KB1	KB2	KL1	KL2
05A2AAB	234 (9.21)	176 (6.93)	129 (5.08)	58 (2.28)	47 (1.85)	56 (2.20)	155 (2.20)	120 (4.72)	88 (3.46)
09A2AAB	257 (10.12)	199 (7.83)	152 (5.98)	58 (2.28)	47 (1.85)	79 (3.11)	178 (7.01)	120 (4.72)	88 (3.46)
13A2AAB	281 (11.06)	223 (8.78)	176 (6.93)	58 (2.28)	47 (1.85)	103 (4.06)	202 (7.95)	120 (4.72)	88 (3.46)
20A2AAB	296 (11.65)	217 (8.54)	170 (6.69)	79 (3.11)	47 (1.85)	79 (3.11)	196 (7.72)	146 (5.75)	88 (3.46)
30A2AAB	322 (12.68)	243 (9.57)	196 (7.72)	79 (3.11)	47 (1.85)	105 (4.13)	222 (8.74)	146 (5.75)	88 (3.46)
44A2AAB	356 (14.02)	277 (10.91)	230 (9.06)	79 (3.11)	47 (1.85)	139 (5.47)	256 (10.08)	146 (5.75)	88 (3.46)

Unit: mm (in)

Model SGMG-	Flange Dimensions											Shaft End Dimensions			Approx. Mass kg (lb)
	LA	LB	LC	LE	LF1	LF2	LG	LH	LJ1	LJ2	LZ	S	S1	Q	
05A2AAB	145 (5.71)	$110 - 0.035$ $(4.33 - 0.0014)$	130 (5.12)	6 (0.24)	6 (0.24)	-	12 (0.47)	165 (6.5)	45 (1.77)	-	9 (0.35)	$19 - 0.013$ $(0.75 - 0.0005)$	30 (1.18)	40 (1.57)	7.5 (16.53)
09A2AAB	145 (5.71)	$110 - 0.035$ $(4.33 - 0.0014)$	130 (5.12)	6 (0.24)	6 (0.24)	-	12 (0.47)	165 (6.5)	45 (1.77)	-	9 (0.35)	$19 - 0.013$ $(0.75 - 0.0005)$	30 (1.18)	40 (1.57)	9.6 (21.16)
13A2AAB	145 (5.71)	$110 - 0.035$ $(4.33 - 0.0014)$	130 (5.12)	6 (0.24)	6 (0.24)	-	12 (0.47)	165 (6.5)	45 (1.77)	-	9 (0.35)	$22 - 0.013$ $(0.87 - 0.0005)$	30 (1.18)	40 (1.57)	12 26.45
20A2AAB	200 (7.87)	$114.3 - 0.025$ $(4.50 - 0.0010)$	180 (7.09)	3.2 (0.13)	3 (0.12)	0.5 (0.0197)	18 (0.71)	230 (9.06)	76 (2.99)	62 (2.44)	13.5 (0.53)	$35 + 0.01$ $(1.38 + 0.0004)$	45 (1.77)	76 (2.99)	19 (41.88)
30A2AAB	200 (7.87)	$114.3 - 0.025$ $(4.50 - 0.0010)$	180 (7.09)	3.2 (0.13)	3 (0.12)	0.5 (0.0197)	18 (0.71)	230 (9.06)	76 (2.99)	62 (2.44)	13.5 (0.53)	$35 + 0.01$ $(1.38 + 0.0004)$	45 (1.77)	76 (2.99)	23.5 (51.79)
44A2AAB	200 (7.87)	$114.3 - 0.025$ $(4.50 - 0.0010)$	180 (7.09)	3.2 (0.13)	3 (0.12)	0.5 (0.0197)	18 (0.71)	230 (9.06)	76 (2.99)	62 (2.44)	13.5 (0.53)	$35 + 0.01$ $(1.38 + 0.0004)$	45 (1.77)	76 (2.99)	28.5 (62.81)

Note: An incremental encoder (8192 P/R) is used as a detector.

● Connector Wiring on Motor End

A	Phase U	E	Brake terminal
B	Phase V	F	Brake terminal
C	Phase W	G	---
D	FG (Frame Ground)		

- 5.5 to 15 kW

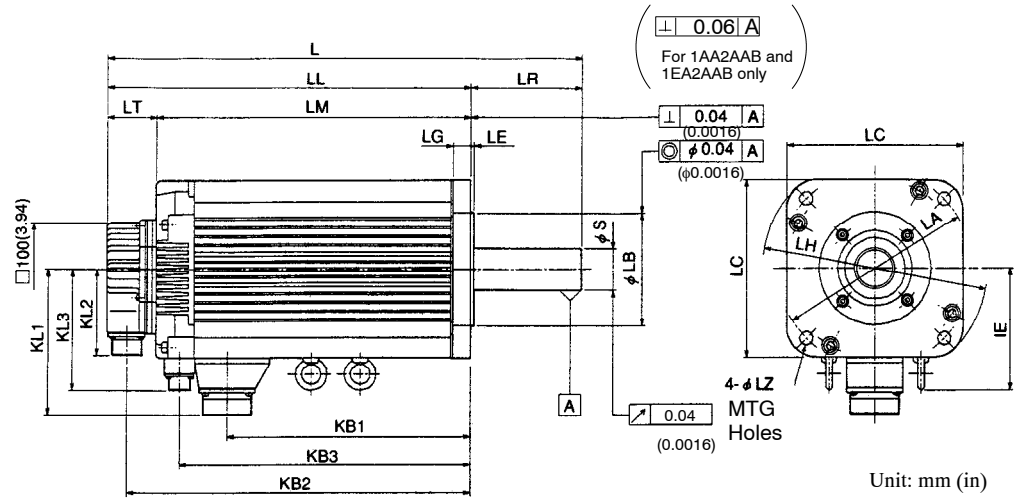

Detailed View of Shaft End

SGMG-55A2AAB and -75A2AAB

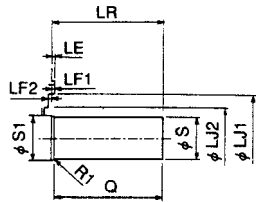

SGMG-1AA2AAB and -1EA2AAB

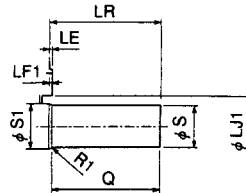

Unit: mm (in)

Model SGMG-	L	LL	LM	LR	LT	KB1	KB2	KB3	IE	KL1	KL2	KL3
55A2AAB	424 (16.69)	311 (12.24)	264 (10.39)	113 (4.45)	47 (1.85)	174 (6.85)	290 (11.42)	231 (9.09)	125 (4.92)	150 (5.91)	88 (3.46)	123 (4.84)
75A2AAB	498 (19.61)	385 (15.16)	338 (13.31)	113 (4.45)	47 (1.85)	248 (9.76)	364 (14.33)	305 (12.01)	125 (4.92)	150 (5.91)	88 (3.46)	123 (4.84)
1AA2AAB	499 (19.65)	383 (15.08)	340 (13.39)	116 (4.57)	43 (1.69)	258 (10.16)	362 (14.25)	315 (12.40)	142 (5.59)	168 (6.61)	88 (3.46)	142 (5.59)
1EA2AAB	635 (25.00)	519 (20.43)	473 (18.62)	116 (4.57)	46 (1.81)	343 (13.50)	497 (19.57)	415 (16.34)	142 (5.59)	168 (6.61)	88 (3.46)	142 (5.59)

Unit: mm (in)

Model SGMG-	Flange Dimensions											Shaft End Dimensions			Approx. Mass kg (lb)
	LA	LB	LC	LE	LF1	LF2	LG	LH	LJ1	LJ2	LZ	S	S1	Q	
55A2A AB	200 (7.87)	$114.3 - 0.025$ $(4.50 - 0.0010)$	180 (7.09)	3.2 (0.13)	3 (0.12)	0.5 (0.0197)	18 (0.71)	230 (9.06)	76 (2.99)	62 (2.44)	13.5 (0.53)	$42 - 0.016$ $(1.65 - 0.0006)$	45 (1.77)	110 (4.33)	35 (77.14)
75A2A AB	200 (7.87)	$114.3 - 0.025$ $(4.50 - 0.0010)$	180 (7.09)	3.2 (0.13)	3 (0.12)	0.5 (0.0197)	18 (0.71)	230 (9.06)	76 (2.99)	62 (2.44)	13.5 (0.53)	$42 - 0.016$ $(1.65 - 0.0006)$	45 (1.77)	110 (4.33)	45.5 (100.28)
1AA2A AB	235 (9.25)	$200 - 0.046$ $(7.87 - 0.0018)$	220 (8.66)	4 (0.16)	4 (0.16)	-	18 (0.71)	270 (10.63)	62 (2.44)	-	13.5 (0.53)	$42 - 0.016$ $(1.65 - 0.0006)$	45 (1.77)	110 (4.33)	65 (143.26)
1EA2A AB	235 (9.25)	$200 - 0.046$ $(7.87 - 0.0018)$	220 (8.66)	4 (0.16)	4 (0.16)	-	20 (0.79)	270 (10.63)	85 (3.35)	-	13.5 (0.53)	$55 + 0.030$ $(2.17 + 0.0012)$ $+ 0.011$ $+ 0.0004$	65 (2.56)	110 (4.33)	100 (220.46)

Note: An incremental encoder (8192 P/R) is used as a detector.

● Connector Wiring on Brake and Motor Ends



A	Brake terminal
B	Brake terminal
C	---

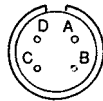

A	Phase U
B	Phase V
C	Phase W
D	Frame ground (FG)

With Absolute Encoder (15-bit : 8192 P/R)

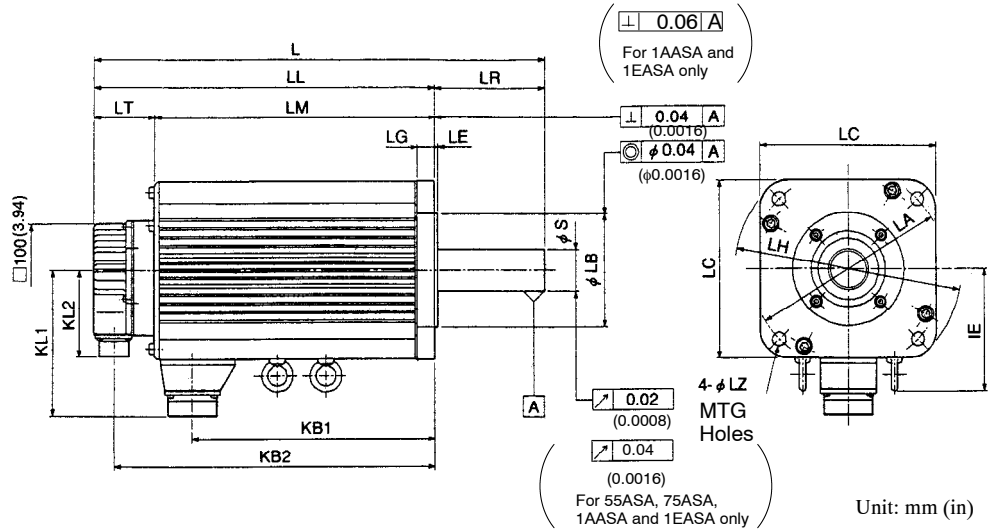

Detailed View of Shaft End

SGMG-05ASA to -13ASA, -1AASA and -1EASA

SGMG-20ASA to -75ASA

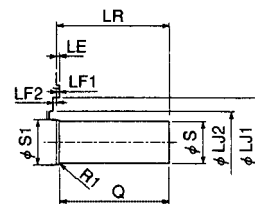
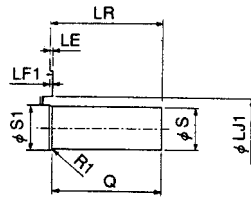

Unit: mm (in)

Model SGMG-	L	LL	LM	LR	LT	KB1	KB2	IE	KL1	KL2
05ASA	210 (8.27)	152 (5.98)	92 (3.62)	58 (2.28)	60 (2.36)	65 (2.56)	131 (5.16)	-	109 (4.29)	88 (3.46)
09ASA	233 (9.17)	175 (6.89)	115 (4.53)	58 (2.28)	60 (2.36)	88 (3.46)	154 (6.06)	-	109 (4.29)	88 (3.46)
13ASA	257 (10.12)	199 (7.83)	139 (5.47)	58 (2.28)	60 (2.36)	112 (4.41)	178 (7.01)	-	109 (4.29)	88 (3.46)
20ASA	259 (10.20)	180 (7.09)	119 (4.69)	79 (3.11)	61 (2.40)	89 (3.50)	159 (6.26)	-	140 (5.51)	88 (3.46)
30ASA	285 (11.22)	206 (8.11)	145 (5.71)	79 (3.11)	61 (2.40)	115 (4.53)	185 (7.28)	-	140 (5.51)	88 (3.46)
44ASA	319 (12.56)	240 (9.45)	179 (7.05)	79 (3.11)	61 (2.40)	149 (5.87)	219 (8.62)	-	140 (5.51)	88 (3.46)

Unit: mm (in)

Model SGMG-	L	LL	LM	LR	LT	KB1	KB2	IE	KL1	KL2
55ASA	387 (15.24)	274 (10.79)	213 (8.39)	113 (4.45)	61 (2.40)	174 (6.85)	253 (9.96)	125 (4.92)	150 (5.91)	88 (3.46)
75ASA	461 (18.15)	348 (13.70)	287 (11.30)	113 (4.45)	61 (2.40)	248 (9.76)	327 (12.87)	125 (4.92)	150 (5.91)	88 (3.46)
1AASA	468 (18.43)	352 (13.86)	291 (11.46)	116 (4.57)	61 (2.40)	251 (9.88)	331 (13.03)	142 (5.59)	168 (6.61)	88 (3.46)
1EASA	587 (23.11)	471 (18.54)	388 (15.28)	116 (4.57)	83 (3.27)	343 (13.50)	449 (17.68)	142 (5.59)	168 (6.61)	88 (3.46)

Model SGMG-	Flange Dimensions											Shaft End Dimensions			Approx. Mass kg (lb)
	LA	LB	LC	LE	LF1	LF2	LG	LH	LJ1	LJ2	LZ	S	S1	Q	
05ASA	145 (5.71)	110 ⁰ _{-0.035} (4.33 - 0.0014)	130 (5.12)	6 (0.24)	6 (0.24)	-	12 (0.47)	165 (6.50)	45 (1.77)	-	9 (0.35)	19 ⁰ _{-0.013} (0.75 - 0.0005)	30 (1.18)	40 (1.57)	5.9 (13.00)
09ASA	145 (5.71)	110 ⁰ _{-0.035} (4.33 - 0.0014)	130 (5.12)	6 (0.24)	6 (0.24)	-	12 (0.47)	165 (6.50)	45 (1.77)	-	9 (0.35)	19 ⁰ _{-0.013} (0.75 - 0.0005)	30 (1.18)	40 (1.57)	8.0 (17.63)
13ASA	145 (5.71)	110 ⁰ _{-0.035} (4.33 - 0.0014)	130 (5.12)	6 (0.24)	6 (0.24)	-	12 (0.47)	165 (6.50)	45 (1.77)	-	9 (0.35)	22 ⁰ _{-0.013} (0.87 - 0.0005)	30 (1.18)	40 (1.57)	10 (22.04)
20ASA	200 (7.87)	114.3 ⁰ _{-0.025} (4.50 - 0.0010)	180 (7.09)	3.2 (0.13)	3 (0.12)	0.5 (0.0197)	18 (0.71)	230 (9.06)	76 (2.99)	62 (2.44)	13.5 (0.53)	35 ^{+0.01} ₀ (1.38 + 0.0004)	45 (1.77)	76 (2.99)	14 (30.86)
30ASA	200 (7.87)	114.3 ⁰ _{-0.025} (4.50 - 0.0010)	180 (7.09)	3.2 (0.13)	3 (0.12)	0.5 (0.0197)	18 (0.71)	230 (9.06)	76 (2.99)	62 (2.44)	13.5 (0.53)	35 ^{+0.01} ₀ (1.38 + 0.0004)	45 (1.77)	76 (2.99)	18.5 (40.77)
44ASA	200 (7.87)	114.3 ⁰ _{-0.025} (4.50 - 0.0010)	180 (7.09)	3.2 (0.13)	3 (0.12)	0.5 (0.0197)	18 (0.71)	230 (9.06)	76 (2.99)	62 (2.44)	13.5 (0.53)	35 ^{+0.01} ₀ (1.38 + 0.0004)	45 (1.77)	76 (2.99)	24 (52.90)
55ASA	200 (7.87)	114.3 ⁰ _{-0.025} (4.50 - 0.0010)	180 (7.09)	3.2 (0.13)	3 (0.12)	0.5 (0.0197)	18 (0.71)	230 (9.06)	76 (2.99)	62 (2.44)	13.5 (0.53)	42 ⁰ _{-0.016} (1.65 - 0.0006)	45 (1.77)	110 (4.33)	30 (66.12)
75ASA	200 (7.87)	114.3 ⁰ _{-0.025} (4.50 - 0.0010)	180 (7.09)	3.2 (0.13)	3 (0.12)	0.5 (0.0197)	18 (0.71)	230 (9.06)	76 (2.99)	62 (2.44)	13.5 (0.53)	42 ⁰ _{-0.016} (1.65 - 0.0006)	45 (1.77)	110 (4.33)	40 (88.16)
1AASA	235 (9.25)	200 ⁰ _{-0.046} (7.87 - 0.0018)	220 (8.66)	4 (0.16)	4 (0.16)	-	18 (0.71)	270 (10.63)	62 (2.44)	-	13.5 (0.53)	42 ⁰ _{-0.016} (1.65 - 0.0006)	45 (1.77)	110 (4.33)	58 (127.83)
1EASA	235 (9.25)	200 ⁰ _{-0.046} (7.87 - 0.0018)	220 (8.66)	4 (0.16)	4 (0.16)	-	20 (0.79)	270 (10.63)	85 (3.35)	-	13.5 (0.53)	55 ^{+0.030} _{+0.011} (2.17 + 0.0004)	65 (2.56)	110 (4.33)	86 (189.6)

Note: 1. An absolute encoder (15-bit : 8192 P/R) is used as a detector.

2. SGMG-05ASA to -44ASA do not contain eyebolts.

- Connector Wiring on Detector End

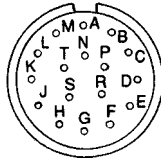

Receptacle: MS3102A20-29P
 Plug (To be prepared by customer) (L type): MS3108B20-29S or
 (Straight type) MS3106B20-29
 Cable Clamp: (To be prepared by customer) MS3057-12A

A	A channel output	K	---
B	\bar{A} channel output	L	---
C	B channel output	M	---
D	\bar{B} channel output	N	---
E	Z (C) channel output	P	---
F	\bar{Z} (\bar{C}) channel output	R	Reset
G	0 V (battery)	S	0 V
H	+5 VDC	T	3.6 V (battery)
J	FG (Frame Ground)		

Note: 1. Terminals K to P are not used. Do not connect anything.

2. Receptacle, plug and cable clamp are common regardless of motor capacity.

- Connector Wiring on Motor End

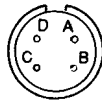

A	Phase U
B	Phase V
C	Phase W
D	Ground terminal

Note: Receptacle, plug and cable clamp differ depending on the capacity. Refer to *Connectors on Detector and Motor Ends* (page 6 -127).

With Absolute Encoder (15-bit : 8192 P/R) and Brake

- 0.5 to 4.4 kW

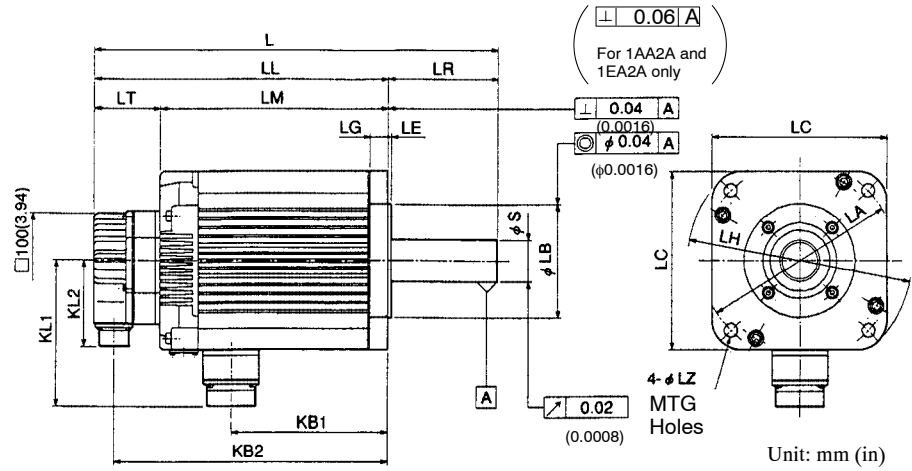

Detailed View of Shaft End

SGMG-05ASAAB to -13ASAAB

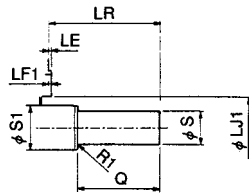

SGMG-20ASAAB to -44ASAAB

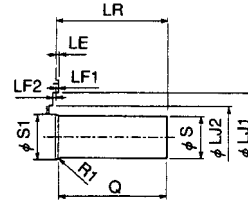

Unit: mm (in)

Model SGMG-	L	LL	LM	LR	LT	KB1	KB2	KL1	KL2
05ASAAB	248 (9.76)	190 (7.48)	129 (5.08)	58 (2.28)	61 (2.40)	56 (2.20)	169 (6.65)	120 (4.72)	88 (3.46)
09ASAAB	271 (10.67)	213 (8.39)	152 (5.98)	58 (2.28)	61 (2.40)	79 (3.11)	192 (7.56)	120 (4.72)	88 (3.46)
13ASAAB	295 (11.61)	237 (9.33)	176 (6.93)	58 (2.28)	61 (2.40)	103 (4.06)	216 (8.50)	120 (4.72)	88 (3.46)
20ASAAB	310 (12.20)	231 (9.09)	170 (6.69)	79 (3.11)	61 (2.40)	79 (3.11)	210 (8.27)	146 (5.75)	88 (3.46)
30ASAAB	336 (13.23)	257 (10.12)	196 (7.72)	79 (3.11)	61 (2.40)	105 (4.13)	236 (9.29)	146 (5.75)	88 (3.46)
44ASAAB	370 (14.57)	291 (11.46)	230 (9.06)	79 (3.11)	61 (2.40)	139 (5.47)	270 (10.63)	146 (5.75)	88 (3.46)

Unit: mm (in)

Model SGMG-	Flange Dimensions											Shaft End Dimensions			Approx. Mass kg (lb)
	LA	LB	LC	LE	LF1	LF2	LG	LH	LJ1	LJ2	LZ	S	S1	Q	
05ASA AB	145 (5.71)	$110 - 0.035$ _(4.33 - 0.0014)	130 (5.12)	6 (0.24)	6 (0.24)	-	12 (0.47)	165 (6.50)	45 (1.77)	-	9 (0.35)	$19 - 0.013$ _(0.75 - 0.0005)	30 (1.18)	40 (1.57)	7.9 (17.41)
09ASA AB	145 (5.71)	$110 - 0.035$ _(4.33 - 0.0014)	130 (5.12)	6 (0.24)	6 (0.24)	-	12 (0.47)	165 (6.50)	45 (1.77)	-	9 (0.35)	$19 - 0.013$ _(0.75 - 0.0005)	30 (1.18)	40 (1.57)	10 (22.04)
13ASA AB	145 (5.71)	$110 - 0.035$ _(4.33 - 0.0014)	130 (5.12)	6 (0.24)	6 (0.24)	-	12 (0.47)	165 (6.50)	45 (1.77)	-	9 (0.35)	$22 - 0.013$ _(0.87 - 0.0005)	30 (1.18)	40 (1.57)	12 (26.45)
20ASA AB	200 (7.87)	$114.3 - 0.025$ _(4.50 - 0.0010)	180 (7.09)	3.2 (0.13)	3 (0.12)	0.5 (0.0197)	18 (0.71)	230 (9.06)	76 (2.99)	62 (2.44)	13.5 (0.53)	$35 + 0.01$ _(1.38 + 0.0004)	45 (1.77)	76 (2.99)	19.5 (42.98)
30ASA AB	200 (7.87)	$114.3 - 0.025$ _(4.50 - 0.0010)	180 (7.09)	3.2 (0.13)	3 (0.12)	0.5 (0.0197)	18 (0.71)	230 (9.06)	76 (2.99)	62 (2.44)	13.5 (0.53)	$35 + 0.01$ _(1.38 + 0.0004)	45 (1.77)	76 (2.99)	23.5 (51.79)
44ASA AB	200 (7.87)	$114.3 - 0.025$ _(4.50 - 0.0010)	180 (7.09)	3.2 (0.13)	3 (0.12)	0.5 (0.0197)	18 (0.71)	230 (9.06)	76 (2.99)	62 (2.44)	13.5 (0.53)	$35 + 0.01$ _(1.38 + 0.0004)	45 (1.77)	76 (2.99)	29 (63.92)

Note: An absolute encoder (15-bit : 8192 P/R) is used as a detector.

● Connector Wiring on Motor End

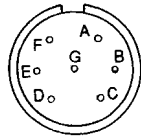

A	Phase U	E	Brake terminal
B	Phase V	F	Brake terminal
C	Phase W	G	---
D	Frame ground (FG)		

● 5.5 to 15 kW

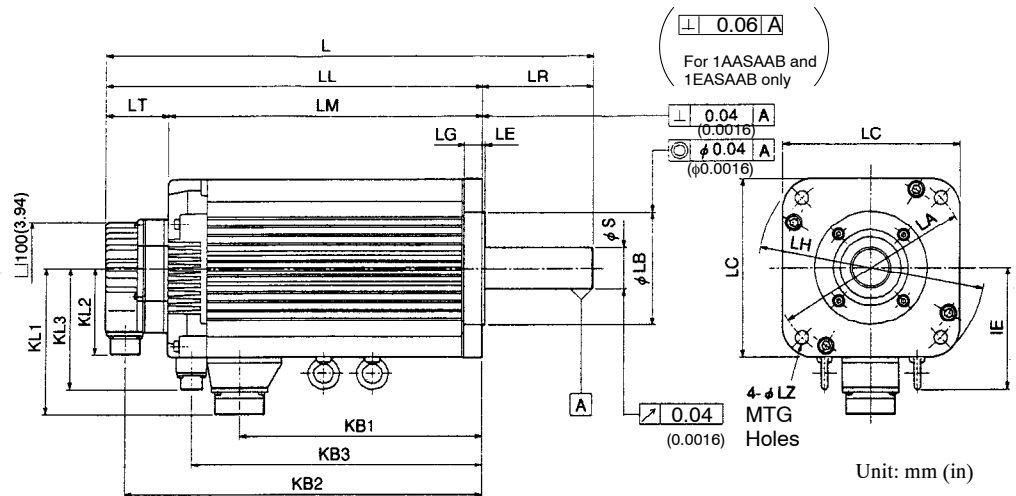

Detailed View of Shaft End

SGMG-55ASAAB and -75ASAAB

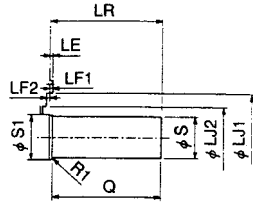

SGMG-1AASAAB and -1EASAAB

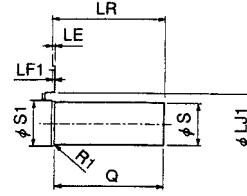

Unit: mm (in)

Model SGMG-	L	LL	LM	LR	LT	KB1	KB2	KB3	IE	KL1	KL2	KL3
55ASAAB	438 (17.24)	325 (12.80)	264 (10.39)	113 (4.45)	61 (2.40)	174 (6.85)	304 (11.97)	231 (9.09)	125 (4.92)	150 (5.91)	88 (3.46)	123 (4.84)
75ASAAB	512 (20.16)	399 (15.71)	338 (13.31)	113 (4.45)	61 (2.40)	248 (9.76)	378 (14.88)	305 (12.01)	125 (4.92)	150 (5.91)	88 (3.46)	123 (4.84)
1AASAAB	513 (20.20)	397 (15.63)	340 (13.39)	116 (4.57)	57 (2.24)	258 (10.16)	376 (14.80)	315 (12.40)	142 (5.59)	168 (6.61)	88 (3.46)	142 (5.59)
1EASAAB	649 (25.53)	533 (20.98)	473 *18.62)	116 (4.57)	60 (2.36)	343 (13.50)	511 (20.12)	415 (16.39)	142 (5.59)	168 (6.61)	88 (3.46)	142 (5.59)

Model SGMG-	Flange Dimensions											Shaft End Dimensions			Approx. Mass kg (lb)
	LA	LB	LC	LE	LF1	LF2	LG	LH	LJ1	LJ2	LZ	S	S1	Q	
55ASA AB	200 (7.87)	114.3 ⁰ _{-0.025} (4.50 ⁰ _{-0.0010})	180 (7.09)	3.2 (0.13)	3 (0.12)	0.5 (0.0197)	18 (0.71)	230 (9.06)	76 (2.99)	62 (2.44)	13.5 (0.53)	42 ⁰ _{-0.016} (1.65 ⁰ _{-0.0006})	45 (1.77)	110 (4.33)	36 (79.34)
75ASA AB	200 (7.87)	114.3 ⁰ _{-0.025} (4.50 ⁰ _{-0.0010})	180 (7.09)	3.2 (0.13)	3 (0.12)	0.5 (0.0197)	18 (0.71)	230 (9.06)	76 (2.99)	62 (2.44)	13.5 (0.53)	42 ⁰ _{-0.016} (1.65 ⁰ _{-0.0006})	45 (1.77)	110 (4.33)	50 (110.20)
1AASA AB	235 (9.25)	200 ⁰ _{-0.046} (7.87 ⁰ _{-0.0018})	220 (8.66)	4 (0.16)	4 (0.16)	-	18 (0.71)	270 (10.63)	62 (2.44)	-	13.5 (0.53)	42 ⁰ _{-0.016} (1.65 ⁰ _{-0.0006})	45 (1.77)	110 (4.33)	65.5 (144.36)
1EASA AB	235 (9.25)	200 ⁰ _{-0.046} (7.87 ⁰ _{-0.0018})	220 (8.66)	4 (0.16)	4 (0.16)	-	20 (0.79)	270 (10.63)	85 (3.35)	-	13.5 (0.53)	55 ^{+0.030} _{+0.011} (2.17 ^{+0.0012} _{+0.0004})	65 (2.56)	110 (4.33)	100 (220.46)

Note: An absolute encoder (15-bit : 8192 P/R) is used as a detector.

6

● Connector Wiring on Brake and Motor End



A	Brake terminal
B	Brake terminal
C	---

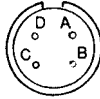

A	Phase U
B	Phase V
C	Phase W
D	Frame ground (FG)

■ SGMG-□□A□B Servomotors (1000 min⁻¹)

With Incremental Encoder (8192 P/R)

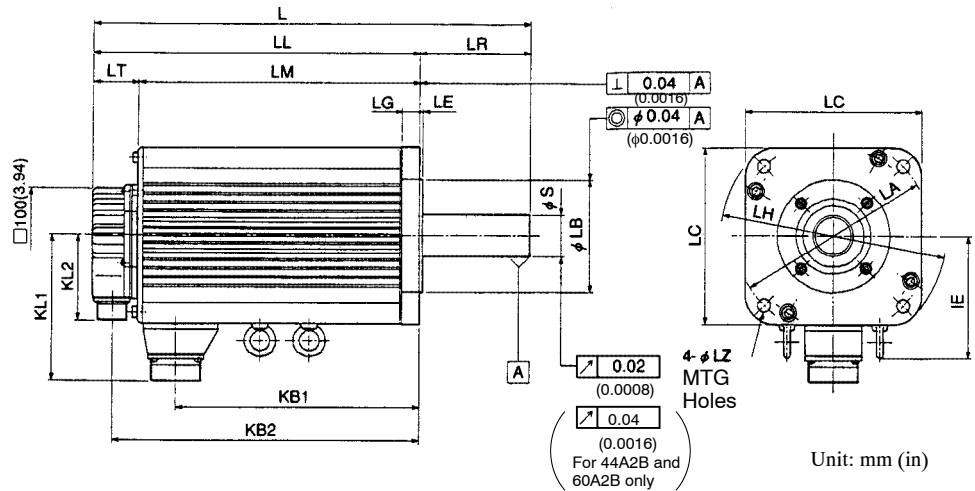

Detailed View of Shaft End

SGMG-03A2B to -09A2B

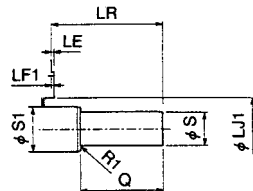

SGMG-12A2B to -60A2B

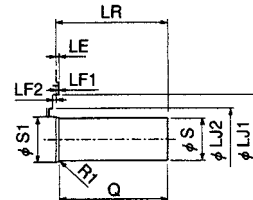

Unit: mm (in)

Model SGMG-	L	LL	LM	LR	LT	KB1	KB2	IE	KL1	KL2
03A2B	196 (7.72)	138 (5.43)	92 (3.62)	58 (2.28)	46 (1.81)	65 (2.56)	117 (4.61)	-	109 (4.29)	88 (3.46)
06A2B	219 (8.62)	161 (6.34)	115 (4.53)	58 (2.28)	46 (1.81)	88 (3.46)	140 (5.51)	-	109 (4.29)	88 (3.46)
09A2B	243 (9.57)	185 (7.28)	139 (5.47)	58 (2.28)	46 (1.81)	112 (4.41)	164 (6.46)	-	109 (4.29)	88 (3.46)
12A2B	245 (9.65)	166 (6.54)	119 (4.69)	79 (3.11)	47 (1.85)	89 (3.50)	145 (5.71)	-	140 (5.51)	88 (3.46)
20A2B	271 (10.67)	192 (7.56)	145 (5.71)	79 (3.11)	47 (1.85)	115 (4.53)	171 (6.73)	-	140 (5.51)	88 (3.46)
30A2B	305 (12.01)	226 (8.90)	179 (7.05)	79 (3.11)	47 (1.85)	149 (5.87)	205 (8.07)	-	140 (5.51)	88 (3.46)
44A2B	373 (14.69)	260 (10.24)	213 (8.39)	113 (4.45)	47 (1.85)	174 (6.85)	239 (9.41)	125 (4.92)	150 (5.91)	88 (3.46)
60A2B	447 (17.60)	334 (13.15)	287 (11.30)	113 (4.45)	47 (1.85)	248 (9.76)	313 (12.32)	125 (4.92)	150 (5.91)	88 (3.46)

Model SGMG-	Flange Dimensions											Shaft End Dimensions			Approx. Mass kg (lb)
	LA	LB	LC	LE	LF1	LF2	LG	LH	LJ1	LJ2	LZ	S	S1	Q	
03A2B	145 (5.71)	110 ⁰ _{-0.035} (4.33 - 0.0014)	130 (5.12)	6 (0.24)	6 (0.24)	-	12 (0.47)	165 (6.50)	45 (1.77)	-	9 (0.35)	19 ⁰ _{-0.013} (0.75 - 0.0005)	30 (1.18)	40 (1.57)	5.5 (12.12)
06A2B	145 (5.71)	110 ⁰ _{-0.035} (4.33 - 0.0014)	130 (5.12)	6 (0.24)	6 (0.24)	-	12 (0.47)	165 (6.50)	45 (1.77)	-	9 (0.35)	19 ⁰ _{-0.013} (0.75 - 0.0005)	30 (1.18)	40 (1.57)	7.6 (16.75)
09A2B	145 (5.71)	110 ⁰ _{-0.035} (4.33 - 0.0014)	130 (5.12)	6 (0.24)	6 (0.24)	-	12 (0.47)	165 (6.50)	45 (1.77)	-	9 (0.35)	22 ⁰ _{-0.013} (0.87 - 0.0005)	30 (1.18)	40 (1.57)	9.6 (21.16)
12A2B	200 (7.87)	114.3 ⁰ _{-0.025} (4.50 - 0.0010)	180 (7.09)	3.2 (0.13)	3 (0.12)	0.5 (0.0197)	18 (0.71)	230 (9.06)	76 (2.99)	62 (2.44)	13.5 (0.53)	35 ^{+0.01} ₀ (1.38 + 0.0004)	45 (1.77)	76 (2.99)	14 (30.86)
20A2B	200 (7.87)	114.3 ⁰ _{-0.025} (4.50 - 0.0010)	180 (7.09)	3.2 (0.13)	3 (0.12)	0.5 (0.0197)	18 (0.71)	230 (9.06)	76 (2.99)	62 (2.44)	13.5 (0.53)	35 ^{+0.01} ₀ (1.38 + 0.0004)	45 (1.77)	76 (2.99)	18 (39.62)
30A2B	200 (7.87)	114.3 ⁰ _{-0.025} (4.50 - 0.0010)	180 (7.09)	3.2 (0.13)	3 (0.12)	0.5 (0.0197)	18 (0.71)	230 (9.06)	76 (2.99)	62 (2.44)	13.5 (0.53)	35 ^{+0.01} ₀ (1.38 + 0.0004)	45 (1.77)	76 (2.99)	23 (50.69)

Unit: mm (in)

Model SGMG-	Flange Dimensions											Shaft End Dimensions			Approx. Mass kg (lb)
	LA	LB	LC	LE	LF1	LF2	LG	LH	LJ1	LJ2	LZ	S	S1	Q	
44A2B	200 (7.87)	114.3 ⁰ _{-0.025} (4.50 ⁰ _{-0.0010})	180 (7.09)	3.2 (0.13)	3 (0.12)	0.5 (0.0197)	18 (0.71)	230 (9.06)	76 (2.99)	62 (2.44)	13.5 (0.53)	42 ⁰ _{-0.016} (1.65 ⁰ _{-0.0006})	45 (1.77)	110 (4.33)	30 (66.12)
60A2B	200 (7.87)	114.3 ⁰ _{-0.025} (4.50 ⁰ _{-0.0010})	180 (7.09)	3.2 (0.13)	3 (0.12)	0.5 (0.0197)	18 (0.71)	230 (9.06)	76 (2.99)	62 (2.44)	13.5 (0.53)	42 ⁰ _{-0.016} (1.65 ⁰ _{-0.0006})	45 (1.77)	110 (4.33)	40 (88.16)

- Note: 1. An incremental encoder (8192 P/R) is used as a detector.
 2. SGMG-03A2B to -30A2B do not contain eyebolts.

● Connector Wiring on Detector End

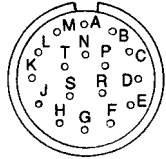

Receptacle: MS3102A20-29-P
 Plug (To be prepared by customer) (L type): MS3108B20-29S or
 (Straight type) MS3106B20-29S
 Cable Clamp: (To be prepared by customer) MS3057-12A

A	A channel output	K	---
B	\bar{A} channel output	L	---
C	B channel output	M	---
D	\bar{B} channel output	N	---
E	C channel output	P	---
F	\bar{C} channel output	R	---
G	0 V	S	---
H	+5 VDC	T	---
J	FG (Frame Ground)		

- Note: 1. Terminals K to T are not used.
 2. Receptacle, plug and cable clamp are common regardless of motor capacity.

● Connector Wiring on Motor End

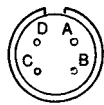

A	Phase U
B	Phase V
C	Phase W
D	Ground terminal

Note: Receptacle, plug and cable clamp differ depending on the capacity. Refer to *Connectors on Detector and Motor Ends* (page 6 -127).

With Incremental Encoder (8192 P/R) and Brake

- 0.3 to 3.0 kW

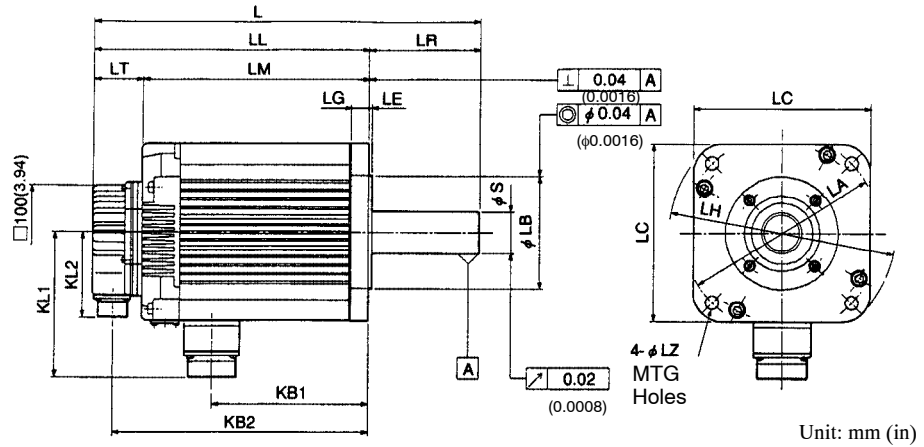

Detailed View of Shaft End

SGMG-03A2BAB to -09A2BAB

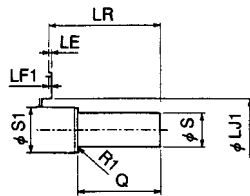

SGMG-12A2BAB to -30A2BAB

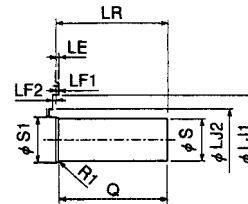

Unit: mm (in)

Model SGMG-	L	LL	LM	LR	LT	KB1	KB2	KL1	KL2
03A2BAB	234 (9.21)	176 (6.93)	129 (5.08)	58 (2.28)	47 (1.85)	56 (2.20)	155 (6.10)	120 (4.72)	88 (3.46)
06A2BAB	257 (10.12)	199 (7.83)	152 (5.98)	58 (2.28)	47 (1.85)	79 (3.11)	178 (7.01)	120 (4.72)	88 (3.46)
09A2BAB	281 (11.06)	223 (8.78)	176 (6.93)	58 (2.28)	47 (1.85)	103 (4.06)	202 (7.95)	120 (4.72)	88 (3.46)
12A2BAB	296 (11.65)	217 (8.54)	170 (6.69)	79 (3.11)	47 (1.85)	79 (3.11)	196 (7.72)	146 (5.75)	88 (3.46)
20A2BAB	322 (12.68)	243 (9.57)	196 (7.72)	79 (3.11)	47 (1.85)	105 (4.13)	222 (8.74)	146 (5.75)	88 (3.46)
30A2BAB	356 (14.02)	277 (10.91)	230 (9.06)	79 (3.11)	47 (1.85)	139 (5.47)	256 (10.08)	146 (5.75)	88 (3.46)

Unit: mm (in)

Model SGMG-	Flange Dimensions											Shaft End Dimensions			Approx. Mass kg (lb)
	LA	LB	LC	LE	LF1	LF2	LG	LH	LJ1	LJ2	LZ	S	S1	Q	
03A2B AB	145 (5.71)	$110 - 0.035$ 0 (4.33 - 0.0014)	130 (5.12)	6 (0.24)	6 (0.24)	-	12 (0.47)	165 (6.50)	45 (1.77)	-	9 (0.35)	$19 - 0.013$ 0 (0.75 - 0.0005)	30 (1.18)	40 (1.57)	7.5 (16.53)
06A2B AB	145 (5.71)	$110 - 0.035$ 0 (4.33 - 0.0014)	130 (5.12)	6 (0.24)	6 (0.24)	-	12 (0.47)	165 (6.50)	45 (1.77)	-	9 (0.35)	$19 - 0.013$ 0 (0.75 - 0.0005)	30 (1.18)	40 (1.57)	9.6 (21.16)
09A2B AB	145 (5.71)	$110 - 0.035$ 0 (4.33 - 0.0014)	130 (5.12)	6 (0.24)	6 (0.24)	-	12 (0.47)	165 (6.50)	45 (1.77)	-	9 (0.35)	$22 - 0.013$ 0 (0.87 - 0.0005)	30 (1.18)	40 (1.57)	12 (26.45)
12A2B AB	200 (7.87)	$114.3 - 0.025$ 0 (4.50 - 0.0010)	180 (7.09)	3.2 (0.13)	3 (0.12)	0.5 (0.0197)	18 (0.71)	230 (9.06)	76 (2.99)	62 (2.44)	13.5 (0.53)	$35 + 0.01$ 0 (1.38 + 0.0004)	45 (1.77)	76 (2.99)	19 (41.88)
20A2B AB	200 (7.87)	$114.3 - 0.025$ 0 (4.50 - 0.0010)	180 (7.09)	3.2 (0.13)	3 (0.12)	0.5 (0.0197)	18 (0.71)	230 (9.06)	76 (2.99)	62 (2.44)	13.5 (13.5)	$35 + 0.01$ 0 (1.38 + 0.0004)	45 (1.77)	76 (2.99)	23.5 (51.79)
30A2B AB	200 (7.87)	$114.3 - 0.025$ 0 (4.50 - 0.0010)	180 (7.09)	3.2 (0.13)	3 (0.12)	0.5 (0.0197)	18 (0.71)	230 (9.06)	76 (2.99)	62 (2.44)	13.5 (0.53)	$35 + 0.01$ 0 (1.38 + 0.0004)	45 (1.77)	76 (2.99)	28.5 (62.81)

Note: An incremental encoder (8192 P/R) is used as a detector.

● Connector Wiring on Motor End

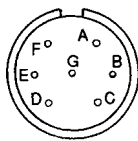

A	Phase U	E	Brake terminal
B	Phase V	F	Brake terminal
C	Phase W	G	---
D	Frame ground (FG)		

6.4.1 Servomotor Dimensional Drawings

- 4.4 to 6.0 kW

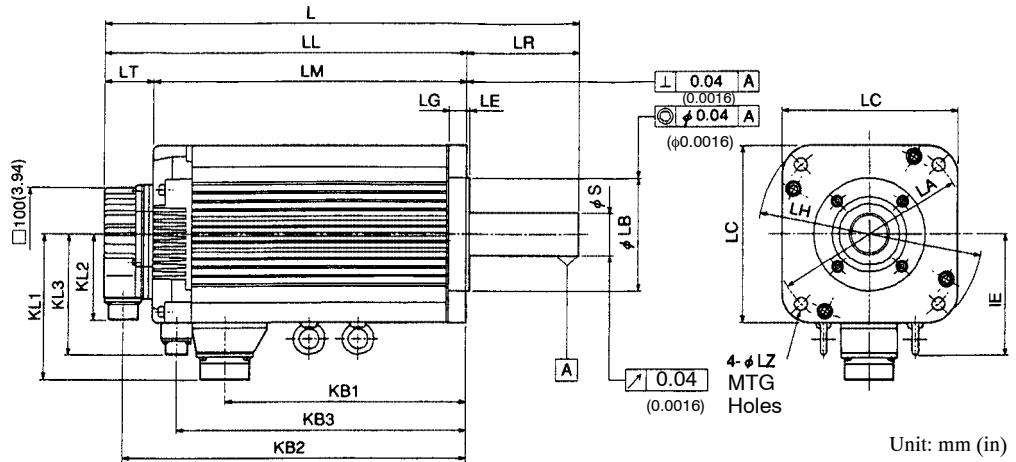

Detailed View of Shaft End

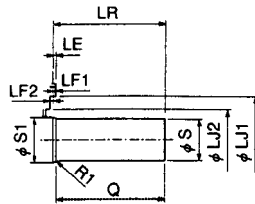

Model SGMG-	L	LL	LM	LR	LT	KB1	KB2	KB3	IE	KL1	KL2	KL3
44A2BAB	424 (16.69)	311 (12.24)	264 (10.39)	113 (4.45)	47 (1.85)	174 (6.85)	290 (11.42)	231 (9.09)	125 (4.92)	150 (5.91)	88 (3.46)	123 (4.84)
60A2BAB	498 (19.61)	385 (15.16)	338 (13.31)	113 (4.45)	47 (1.85)	248 (9.76)	364 (14.33)	305 (12.01)	125 (4.92)	150 (5.91)	88 (3.46)	123 (4.84)

Model SGMG-	Flange Dimensions											Shaft End Dimensions			Approx. Mass kg (lb)
	LA	LB	LC	LE	LF1	LF2	LG	LH	LJ1	LJ2	LZ	S	S1	Q	
44A2B AB	200 (7.87)	114.3 ⁰ _{-0.025} (4.50 ⁰ _{-0.0010})	180 (7.09)	3.2 (0.13)	3 (0.12)	0.5 (0.0197)	18 (0.71)	230 (9.06)	76 (2.99)	62 (2.44)	13.5 (0.53)	42 ⁰ _{-0.016} (1.65 ⁰ _{-0.0006})	45 (1.77)	110 (4.33)	35 (77.14)
60A2B AB	200 (7.87)	114.3 ⁰ _{-0.025} (4.50 ⁰ _{-0.0010})	180 (7.09)	3.2 (0.13)	3 (0.12)	0.5 (0.0197)	18 (0.71)	230 (9.06)	76 (2.99)	62 (2.44)	13.5 (0.53)	42 ⁰ _{-0.016} (1.65 ⁰ _{-0.0006})	45 (1.77)	110 (4.33)	45.5 (100.28)

Note: An incremental encoder (8192 P/R) is used as a detector.

● Connector Wiring on Motor End



A	Brake terminal
B	Brake terminal
C	---

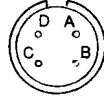

A	Phase U
B	Phase V
C	Phase W
D	Frame ground (FG)

With Absolute Encoder (15-bit : 8192 P/R)

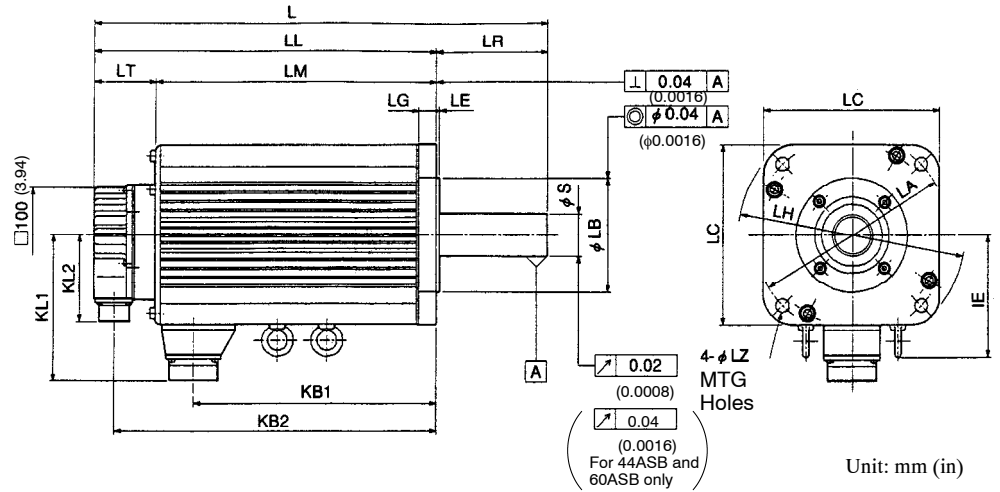

Detailed View of Shaft End

SGMG-03ASB to -09ASB

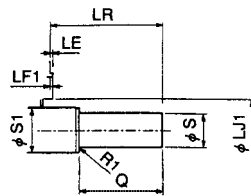

SGMG-12ASB to -60ASB

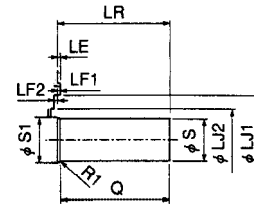

Unit: mm (in)

Model SGMG-	L	LL	LM	LR	LT	KB1	KB2	IE	KL1	KL2
03ASB	210 (8.27)	152 (5.98)	92 (3.62)	58 (2.28)	60 (2.36)	65 (2.56)	131 (5.16)	-	109 (4.29)	88 (3.46)
06ASB	233 (9.17)	175 (6.89)	115 (4.53)	58 (2.28)	60 (2.36)	88 (3.46)	154 (6.06)	-	109 (4.29)	88 (3.46)
09ASB	257 (10.12)	199 (7.83)	139 (5.47)	58 (2.28)	60 (2.36)	112 (4.41)	178 (7.01)	-	109 (4.29)	88 (3.46)
12ASB	259 (10.20)	180 (7.09)	119 (4.69)	79 (3.11)	61 (2.40)	89 (3.50)	159 (6.26)	-	140 (5.51)	88 (3.46)
20ASB	285 (11.22)	206 (8.11)	145 (5.71)	79 (3.11)	61 (2.40)	115 (4.53)	185 (7.28)	-	140 (5.51)	88 (3.46)
30ASB	319 (12.56)	240 (9.45)	179 (7.05)	79 (3.11)	61 (2.40)	149 (5.87)	219 (8.62)	-	140 (5.51)	88 (3.46)
44ASB	387 (15.24)	274 (10.79)	213 (8.39)	113 (4.45)	61 (2.40)	174 (6.85)	253 (9.96)	125 (4.92)	150 (5.91)	88 (3.46)
60ASB	461 (18.15)	348 (13.70)	287 (11.30)	113 (4.45)	61 (2.40)	248 (9.76)	327 (12.87)	125 (4.92)	150 (5.91)	88 (3.46)

Model SGMG-	Flange Dimensions											Shaft End Dimensions			Approx. Mass kg (lb)
	LA	LB	LC	LE	LF1	LF2	LG	LH	LJ1	LJ2	LZ	S	S1	Q	
03ASB	145 (5.71)	110 ⁰ _{-0.035} (4.33 - 0.0014)	130 (5.12)	6 (0.24)	6 (0.24)	-	12 (0.47)	165 (6.50)	45 (1.77)	-	9 (0.35)	19 ⁰ _{-0.013} (0.75 - 0.0005)	30 (1.18)	40 (1.57)	5.9 (13.00)
06ASB	145 (5.71)	110 ⁰ _{-0.035} (4.33 - 0.0014)	130 (5.12)	6 (0.24)	6 (0.24)	-	12 (0.47)	165 (6.50)	45 (1.77)	-	9 (0.35)	19 ⁰ _{-0.013} (0.75 - 0.0005)	30 (1.18)	40 (1.57)	8.0 (17.63)
09ASB	145 (5.71)	110 ⁰ _{-0.035} (4.33 - 0.0014)	130 (5.12)	6 (0.24)	6 (0.24)	-	12 (0.47)	165 (6.50)	45 (1.77)	-	9 (0.35)	22 ⁰ _{-0.013} (0.87 - 0.0005)	30 (1.18)	40 (1.57)	10 (22.04)
12ASB	200 (7.87)	114.3 ⁰ _{-0.025} (4.50 - 0.0010)	180 (7.09)	3.2 (0.13)	3 (0.12)	0.5 (0.0197)	18 (0.71)	230 (9.06)	76 (2.99)	62 (2.44)	13.5 (0.53)	35 ^{+0.01} ₀ (1.38 + 0.0004)	45 (1.77)	76 (2.99)	14 (30.86)
20ASB	200 (7.87)	114.3 ⁰ _{-0.025} (4.50 - 0.0010)	180 (7.09)	3.2 (0.13)	3 (0.12)	0.5 (0.0197)	18 (0.71)	230 (9.06)	76 (2.99)	62 (2.44)	13.5 (0.53)	35 ^{+0.01} ₀ (1.38 + 0.0004)	45 (1.77)	76 (2.99)	18.5 (40.77)
30ASB	200 (7.87)	114.3 ⁰ _{-0.025} (4.50 - 0.0010)	180 (7.09)	3.2 (0.13)	3 (0.12)	0.5 (0.0197)	18 (0.71)	230 (9.06)	76 (2.99)	62 (2.44)	13.5 (0.53)	35 ^{+0.01} ₀ (1.38 + 0.0004)	45 (1.77)	76 (2.99)	24 (52.90)

Unit: mm (in)

Model SGMG-	Flange Dimensions											Shaft End Dimensions			Approx. Mass kg (lb)
	LA	LB	LC	LE	LF1	LF2	LG	LH	LJ1	LJ2	LZ	S	S1	Q	
44ASB	200 (7.87)	114.3 ⁰ _{-0.025} (4.50 ⁰ _{-0.0010})	180 (7.09)	3.2 (0.13)	3 (0.12)	0.5 (0.0197)	18 (0.71)	230 (9.06)	76 (2.99)	62 (2.44)	13.5 (0.53)	42 ⁰ _{-0.016} (1.65 ⁰ _{-0.0006})	45 (1.77)	110 (4.33)	30 (66.12)
60ASB	200 (7.87)	114.3 ⁰ _{-0.025} (4.50 ⁰ _{-0.0010})	180 (7.09)	3.2 (0.13)	3 (0.12)	0.5 (0.0197)	18 (0.71)	230 (9.06)	76 (2.99)	62 (2.44)	13.5 (0.53)	42 ⁰ _{-0.016} (1.65 ⁰ _{-0.0006})	45 (1.77)	110 (4.33)	40 (88.16)

Note: 1. An absolute encoder (15-bit : 8192 P/R) is used as a detector.

2. SGMG-03ASB to -30ASB do not contain eyebolts.

● Connector Wiring on Detector End

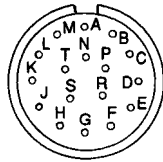

Receptacle: MS3102A20-29P

Plug (To be prepared by customer) (L type): MS3108B20-29S or
(Straight type) MS3106B20-29S

Cable Clamp: (To be prepared by customer) MS3057-12A

A	A channel output	K	---
B	\bar{A} channel output	L	---
C	B channel output	M	---
D	\bar{B} channel output	N	---
E	Z (C) channel output	P	---
F	\bar{Z} (\bar{C}) channel output	R	Reset
G	0 V	S	0 V (battery)
H	+5 VDC	T	3.6 V (battery)
J	FG (Frame Ground)		

Note: 1. Terminals K to P are not used.

2. Receptacle, plug and cable clamp are common regardless of motor capacity.

● Connector Wiring on Motor End

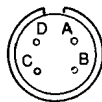

A	Phase U
B	Phase V
C	Phase W
D	Ground terminal

Note: Receptacle, plug and cable clamp differ depending on the capacity. Refer to *Connectors on Detector and Motor Ends* (page 6 -127).

With Absolute Encoder (15-bit : 8192 P/R) and Brake

- 0.3 to 3.0 kW

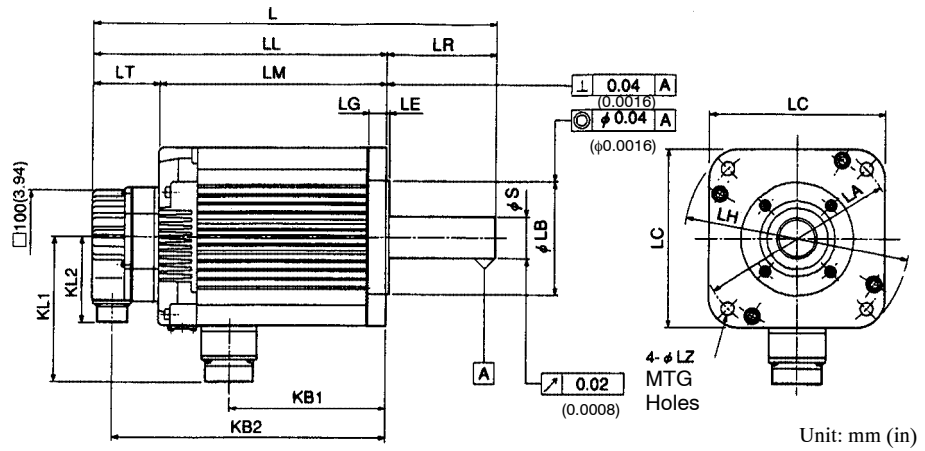

Detailed View of Shaft End

SGMG-03ASBAB to -09ASBAB

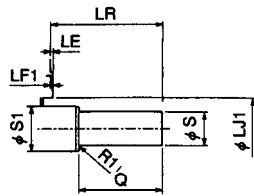

SGMG-12ASBAB to -30ASBAB

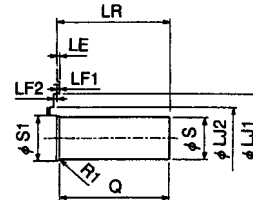

Unit: mm (in)

Model SGMG-	L	LL	LM	LR	LT	KB1	KB2	KL1	KL2
03ASBAB	248 (9.76)	190 (7.48)	129 (5.08)	58 (2.28)	61 (2.40)	56 (2.20)	169 (6.65)	120 (4.72)	88 (3.46)
06ASBAB	271 (10.67)	213 (8.39)	152 (5.98)	58 (2.28)	61 (2.40)	79 (3.11)	192 (7.56)	120 (4.72)	88 (3.46)
09ASBAB	295 (11.61)	237 (9.33)	176 (6.93)	58 (2.28)	61 (2.40)	103 (4.06)	216 (8.50)	120 (4.72)	88 (3.46)
12ASBAB	310 (12.20)	231 (9.09)	170 (6.69)	79 (3.11)	61 (2.40)	79 (3.11)	210 (8.27)	146 (5.75)	88 (3.46)
20ASBAB	336 (13.23)	257 (10.12)	196 (7.72)	79 (3.11)	61 (2.40)	105 (4.13)	236 (9.29)	146 (5.75)	88 (3.46)
30ASBAB	370 (14.57)	291 (11.46)	230 (9.06)	79 (3.11)	61 (2.40)	139 (5.47)	270 (10.63)	146 (5.75)	88 (3.46)

Unit: mm (in)

Model SGMG-	Flange Dimensions											Shaft End Dimensions			Approx. Mass kg (lb)
	LA	LB	LC	LE	LF1	LF2	LG	LH	LJ1	LJ2	LZ	S	S1	Q	
03ASB AB	145 (5.71)	$110 - 0.035$ 0 (4.33 - 0.0014)	130 (5.12)	6 (0.24)	6 (0.24)	-	12 (0.47)	165 (6.50)	45 (1.77)	-	9 (0.35)	$19 - 0.013$ 0 (0.75 - 0.0005)	30 (1.18)	40 (1.57)	7.9 (17.41)
06ASB AB	145 (5.71)	$110 - 0.035$ 0 (4.33 - 0.0014)	130 (5.12)	6 (0.24)	6 (0.24)	-	12 (0.47)	165 (6.50)	45 (1.77)	-	9 (0.35)	$19 - 0.013$ 0 (0.75 - 0.0005)	30 (1.18)	40 (1.57)	10 (22.04)
09ASB AB	145 (5.71)	$110 - 0.035$ 0 (4.33 - 0.0014)	130 (5.12)	6 (0.24)	6 (0.24)	-	12 (0.47)	165 (6.50)	45 (1.77)	-	9 (0.35)	$22 - 0.013$ 0 (0.87 - 0.0005)	30 (1.18)	40 (1.57)	12 (26.45)
12ASB AB	200 (7.87)	$114.3 - 0.025$ 0 (4.50 - 0.0010)	180 (7.09)	3.2 (0.13)	3 (0.12)	0.5 (0.0197)	18 (0.71)	230 (9.06)	76 (2.99)	62 (2.44)	13.5 (0.53)	$35 + 0.01$ 0 (1.38 + 0.0004)	45 (1.77)	76 (2.99)	19.5 (42.98)
20ASB AB	200 (7.87)	$114.3 - 0.025$ 0 (4.50 - 0.0010)	180 (7.09)	3.2 (0.13)	3 (0.12)	0.5 (0.0197)	18 (0.71)	230 (9.06)	76 (2.99)	62 (2.44)	13.5 (0.53)	$35 + 0.01$ 0 (1.38 + 0.0004)	45 (1.77)	76 (2.99)	23.5 (51.79)
30ASB AB	200 (7.87)	$114.3 - 0.025$ 0 (4.50 - 0.0010)	180 (7.09)	3.2 (0.13)	3 (0.12)	0.5 (0.0197)	18 (0.71)	230 (9.06)	76 (2.99)	62 (2.44)	13.5 (0.53)	$35 + 0.01$ 0 (1.38 + 0.0004)	45 (1.77)	76 (2.99)	29 (63.92)

Note: An absolute encoder (15-bit : 8192 P/R) is used as a detector.

● Connector Wiring on Motor End

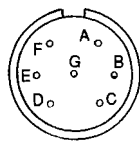

A	Phase U	E	Brake terminal
B	Phase V	F	Brake terminal
C	Phase W	G	---
D	Frame ground (FG)		

6.4.1 Servomotor Dimensional Drawings

- 4.4 to 6.0 kW

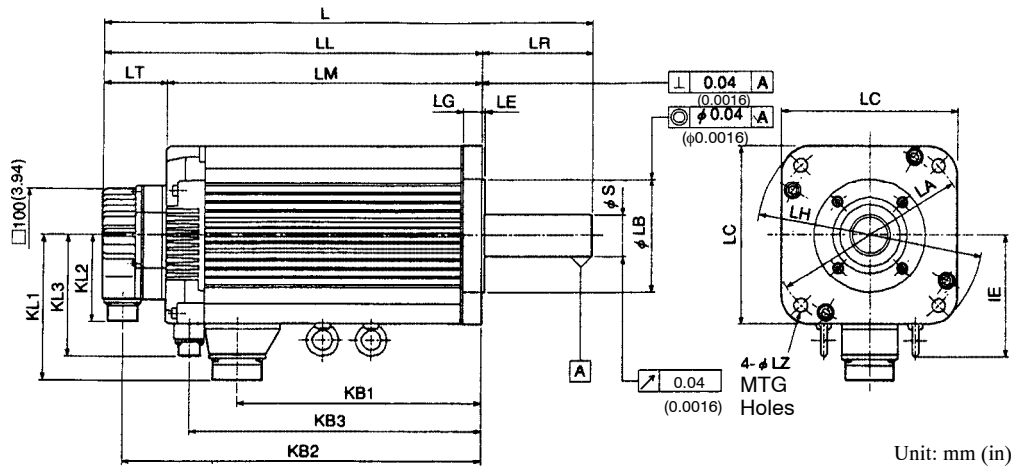

Detailed View of Shaft End

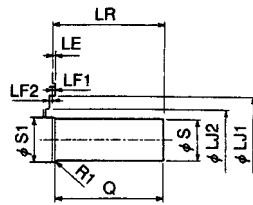

Model SGMG-	L	LL	LM	LR	LT	KB1	KB2	KB3	IE	KL1	KL2	KL3
44ASBAB	438 (17.24)	325 (12.80)	264 (10.39)	113 (4.45)	61 (2.40)	174 (6.85)	304 (11.97)	231 (9.09)	125 (4.92)	150 (5.91)	88 (3.46)	123 (4.84)
60ASBAB	512 (20.16)	399 (15.71)	338 (13.31)	113 (4.45)	61 (2.40)	248 (9.76)	378 (14.88)	305 (12.01)	125 (4.92)	150 (5.91)	88 (3.46)	123 (4.84)

Model SGMG-	Flange Dimensions											Shaft End Dimensions			Approx. Mass kg (lb)
	LA	LB	LC	LE	LF1	LF2	LG	LH	LJ1	LJ2	LZ	S	S1	Q	
44ASB AB	200 (7.87)	114.3 ⁰ _{-0.025} (4.50 - 0.0010)	180 (7.09)	3.2 (0.13)	3 (0.12)	0.5 (0.0197)	18 (0.71)	230 (9.06)	76 (2.99)	62 (2.44)	13.5 (0.53)	42 ⁰ _{-0.016} (1.65 - 0.0006)	45 (1.77)	110 (4.33)	36 (79.34)
60ASB AB	200 (7.87)	114.3 ⁰ _{-0.025} (4.50 - 0.0010)	180 (7.09)	3.2 (0.13)	3 (0.12)	0.5 (0.0197)	18 (0.71)	230 (9.06)	76 (2.99)	62 (2.44)	13.5 (0.53)	42 ⁰ _{-0.016} (1.65 - 0.0006)	45 (1.77)	110 (4.33)	50 (110.20)

Note: An absolute encoder (15-bit : 8192 P/R) is used as a detector.

● Connector Wiring on Brake and Motor Ends



A	Brake terminal
B	Brake terminal
C	---

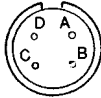

A	Phase U
B	Phase V
C	Phase W
D	Frame ground (FG)

■ SGMS-□□A Servomotors

With Incremental Encoder (4096 P/R)

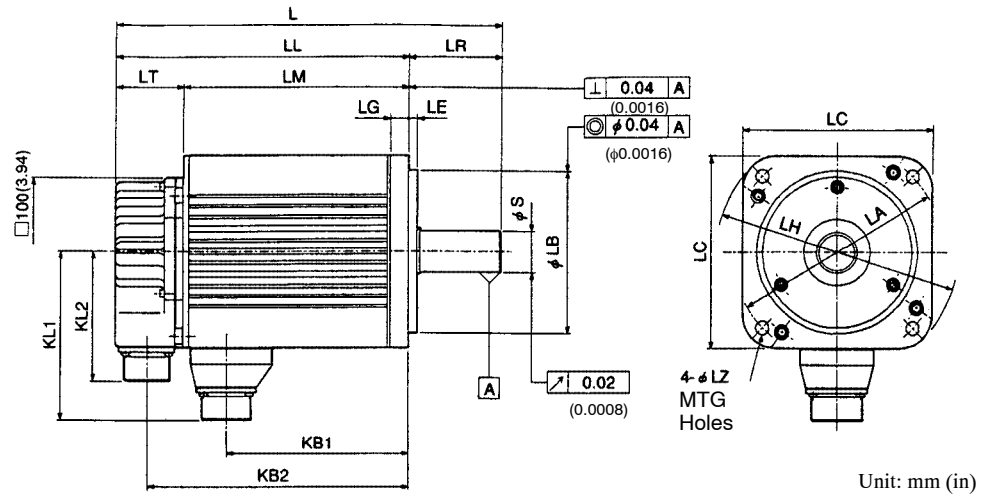

Detailed View of Shaft End

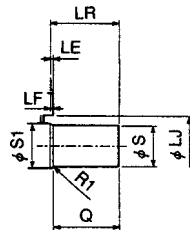

Servo Selection and Data Sheets

6.4.1 Servomotor Dimensional Drawings

Unit: mm (in)

Model SGMS-	L	LL	LM	LR	LT	KB1	KB2	KL1	KL2
10A6A	194 (7.64)	149 (5.87)	103 (4.06)	45 (1.77)	46 (1.81)	76 (2.99)	128 (5.04)	96 (3.78)	87 (3.43)
15A6A	220 (8.66)	175 (6.89)	129 (5.08)	45 (1.77)	46 (1.81)	102 (4.02)	154 (6.06)	96 (3.78)	87 (3.43)
20A6A	243 (9.57)	198 (7.80)	152 (5.98)	45 (1.77)	46 (1.81)	125 (4.92)	177 (6.97)	96 (3.78)	87 (3.43)
30A6A	262 (10.31)	199 (7.83)	153 (6.02)	63 (2.48)	46 (1.81)	122 (4.80)	178 (7.01)	114 (4.49)	87 (3.43)
40A6A	299 (11.77)	236 (9.29)	190 (7.48)	63 (2.48)	46 (1.81)	159 (6.26)	215 (8.46)	114 (4.49)	87 (3.43)
50A6A	339 (13.35)	276 (10.87)	230 (9.06)	63 (2.48)	46 (1.81)	199 (7.83)	255 (10.04)	114 (4.49)	87 (3.43)

Model SGMS-	Flange Dimensions									Shaft End Dimensions			Approx. Mass kg (lb)
	LA	LB	LC	LE	LF	LG	LH	LJ	LZ	S	S1	Q	
10A6A	115 (4.53)	$95 - 0.035$ 0 (3.74 - 0.0014)	100 (3.94)	3 (0.12)	3 (0.12)	10 (0.39)	130 (5.12)	45 (1.77)	7 (0.28)	$24 - 0.013$ 0 (0.94 - 0.0005)	30 (1.18)	40 (1.57)	4.6 (10.14)
15A6A	115 (4.53)	$95 - 0.035$ 0 (3.74 - 0.0014)	100 (3.94)	3 (0.12)	3 (0.12)	10 (0.39)	130 (5.12)	45 (1.77)	7 (0.28)	$24 - 0.013$ 0 (0.94 - 0.0005)	30 (1.18)	40 (1.57)	5.8 (12.78)
20A6A	115 (4.53)	$95 - 0.035$ 0 (3.74 - 0.0014)	100 (3.94)	3 (0.12)	3 (0.12)	10 (0.39)	130 (5.12)	45 (1.77)	7 (0.28)	$24 - 0.013$ 0 (0.94 - 0.0005)	30 (1.18)	40 (1.57)	7.0 (15.43)
30A6A	145 (5.71)	$110 - 0.035$ 0 (4.33 - 0.0014)	130 (5.12)	6 (0.24)	6 (0.24)	12 (0.47)	165 (6.50)	45 (1.77)	9 (0.35)	$28 - 0.013$ 0 (1.10 - 0.0005)	30 (1.18)	55 (2.17)	11 (24.24)
40A6A	145 (5.71)	$110 - 0.035$ 0 (4.33 - 0.0014)	130 (5.12)	6 (0.24)	6 (0.24)	12 (0.47)	165 (6.50)	45 (1.77)	9 (0.35)	$28 - 0.013$ 0 (1.10 - 0.0005)	30 (1.18)	55 (2.17)	14 (30.86)
50A6A	145 (5.71)	$110 - 0.035$ 0 (4.33 - 0.0014)	130 (5.12)	6 (0.24)	6 (0.24)	12 (0.47)	165 (6.50)	45 (1.77)	9 (0.35)	$28 - 0.013$ 0 (1.10 - 0.0005)	30 (1.18)	55 (2.17)	17 (37.47)

Note: An incremental encoder (4096 P/R) is used as a detector.

- Connector Wiring on Detector End

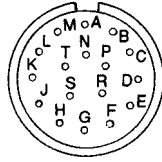

Receptacle: MS3102A20-29P
 Plug (To be prepared by customer) (L type): MS3108B20-29S or
 (Straight type) MS3106B20-29S
 Cable Clamp: (To be prepared by customer) MS3057-12A

A	A channel output	K	---
B	\bar{A} channel output	L	---
C	B channel output	M	---
D	\bar{B} channel output	N	---
E	C channel output	P	---
F	\bar{C} channel output	R	---
G	0 V	S	---
H	+5 VDC	T	---
J	FG (Frame Ground)		

Note: 1. Terminals K to T are not used. Do not connect anything.

2. Receptacle, plug and cable clamp are common regardless of motor capacity.

- Connector Wiring on Motor End

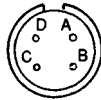

A	Phase U
B	Phase V
C	Phase W
D	Ground terminal

Note: Receptacle, plug and cable clamp differ depending on the capacity. Refer to *Connectors on Detector and Motor Ends* (page 6 -127).

With Incremental Encoder (4096 P/R) and Brake

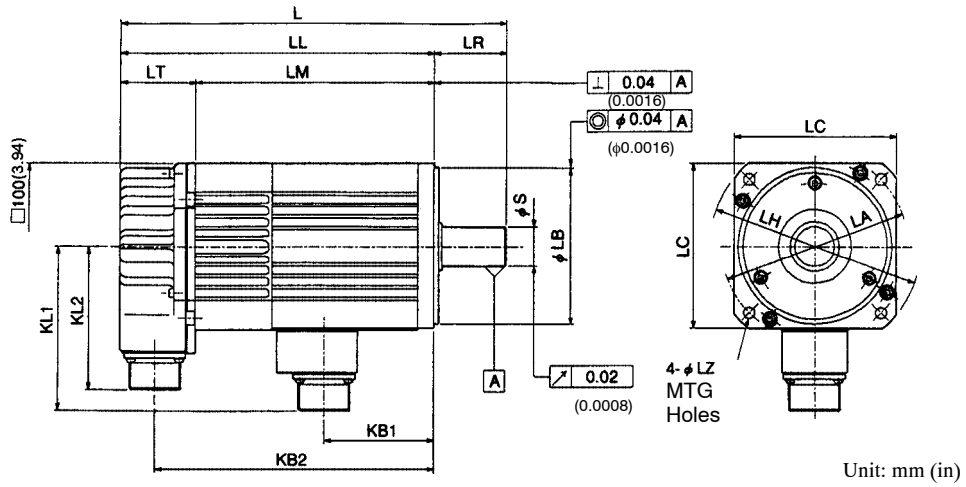

Detailed View of Shaft End

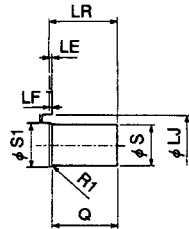

Unit: mm (in)

Model SGMS-	L	LL	LM	LR	LT	KB1	KB2	KL1	KL2
10A6AAB	238 (9.37)	193 (7.60)	147 (5.79)	45 (1.77)	46 (1.81)	67 (2.64)	172 (6.77)	100 (3.94)	87 (3.43)
15A6AAB	264 (10.39)	219 (8.62)	173 (6.81)	45 (1.77)	46 (1.81)	93 (3.66)	198 (7.80)	100 (3.94)	87 (3.43)
20A6AAB	287 (11.30)	242 (9.53)	196 (7.72)	45 (1.77)	46 (1.81)	116 (4.57)	221 (8.70)	100 (3.94)	87 (3.43)
30A6AAB	300 (11.81)	237 (9.33)	191 (7.52)	63 (2.48)	46 (1.81)	113 (4.45)	216 (8.50)	119 (4.69)	87 (3.43)
40A6AAB	336 (13.23)	274 (10.79)	228 (8.98)	63 (2.48)	46 (1.81)	150 (5.91)	253 (9.96)	119 (4.69)	87 (3.43)
50A6AAB	337 (13.27)	314 (12.36)	268 (10.55)	63 (2.48)	46 (1.81)	190 (7.48)	293 (11.54)	119 (4.69)	87 (3.43)

Unit: mm (in)

Model SGMS-	Flange Dimensions									Shaft End Dimensions			Approx. Mass kg (lb)
	LA	LB	LC	LE	LF	LG	LH	LJ	LZ	S	S1	Q	
10A6AAB	115 (4.53)	95 ⁰ - 0.035 (3.74 - 0.0014)	100 (3.94)	3 (0.12)	3 (0.12)	10 (0.39)	130 (5.12)	45 (1.77)	7 (0.28)	24 ⁰ - 0.013 (0.94 - 0.0005)	30 (1.18)	40 (1.57)	6.0 (13.22)
15A6AAB	115 (4.53)	95 ⁰ - 0.035 (3.74 - 0.0014)	100 (3.94)	3 (0.12)	3 (0.12)	10 (0.39)	130 (5.12)	45 (1.77)	7 (0.28)	24 ⁰ - 0.013 (0.94 - 0.0005)	30 (1.18)	40 (1.57)	7.5 (16.53)
20A6AAB	115 (4.53)	95 ⁰ - 0.035 (3.74 - 0.0014)	100 (3.94)	3 (0.12)	3 (0.12)	10 (0.39)	130 (5.12)	45 (1.77)	7 (0.28)	24 ⁰ - 0.013 (0.94 - 0.0005)	30 (1.18)	40 (1.57)	8.5 (18.73)
30A6AAB	145 (5.71)	110 ⁰ - 0.035 (4.33 - 0.0014)	130 (5.12)	6 (0.24)	6 (0.24)	12 (0.47)	165 (6.50)	45 (1.77)	9 (0.35)	28 ⁰ - 0.013 (1.10 - 0.0005)	30 (1.18)	55 (2.17)	14 (30.86)
40A6AAB	145 (5.71)	110 ⁰ - 0.035 (4.33 - 0.0014)	130 (5.12)	6 (0.24)	6 (0.24)	12 (0.47)	165 (6.50)	45 (1.77)	9 (0.35)	28 ⁰ - 0.013 (1.10 - 0.0005)	30 (1.18)	55 (2.17)	17 (37.47)
50A6AAB	145 (5.71)	110 ⁰ - 0.035 (4.33 - 0.0014)	130 (5.12)	6 (0.24)	6 (0.24)	12 (0.47)	165 (6.50)	45 (1.77)	9 (0.35)	28 ⁰ - 0.013 (1.10 - 0.0005)	30 (1.18)	55 (2.17)	20 (44.08)

Note: An incremental encoder (4096 P/R) is used as a detector.

● Connector Wiring on Motor End

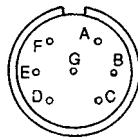

A	Phase U	E	Brake terminal
B	Phase V	F	Brake terminal
C	Phase W	G	---
D	Frame ground (FG)		

With Absolute Encoder (15-bit : 8192 P/R)

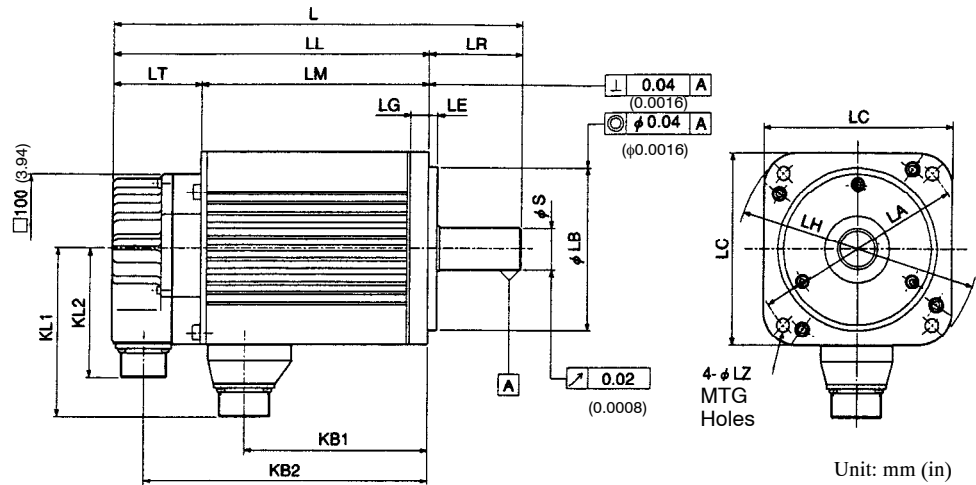

Detailed View of Shaft End

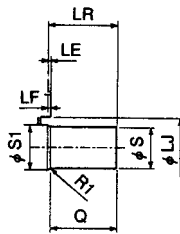

Unit: mm (in)

Model SGMS-	L	LL	LM	LR	LT	KB1	KB2	KL1	KL2
10ASA	208 (8.19)	163 (6.42)	103 (4.06)	45 (1.77)	60 (2.36)	76 (2.99)	142 (5.59)	96 (3.78)	87 (3.43)
15ASA	234 (9.21)	189 (7.44)	129 (5.08)	45 (1.77)	60 (2.36)	102 (4.02)	168 (6.61)	96 (3.78)	87 (3.43)
20ASA	257 (10.12)	212 (8.35)	152 (5.98)	45 (1.77)	60 (2.36)	125 (4.92)	191 (7.52)	96 (3.78)	87 (3.43)
30ASA	276 (10.87)	213 (8.39)	153 (6.02)	63 (2.48)	60 (2.36)	122 (4.80)	192 (7.56)	114 (4.49)	87 (3.43)
40ASA	313 (12.32)	250 (9.84)	190 (7.48)	63 (2.48)	60 (2.36)	159 (6.26)	229 (9.02)	114 (4.49)	87 (3.43)
50ASA	353 (13.90)	290 (11.42)	230 (9.06)	63 (2.48)	60 (2.36)	199 (7.83)	269 (10.59)	114 (4.49)	87 (3.43)

Unit: mm (in)

Model SGMS-	Flange Dimensions									Shaft End Dimensions			Approx. Mass kg (lb)
	LA	LB	LC	LE	LF	LG	LH	LJ	LZ	S	S1	Q	
10ASA	115 (4.53)	$95 - \begin{smallmatrix} 0 \\ 0.035 \end{smallmatrix}$ (3.74 - 0.0014)	100 (3.94)	3 (0.12)	3 (0.12)	10 (0.39)	130 (5.12)	45 (1.77)	7 (0.28)	$24 - \begin{smallmatrix} 0 \\ 0.013 \end{smallmatrix}$ (0.94 - 0.0005)	30 (1.18)	40 (1.57)	5.0 (11.02)
15ASA	115 (4.53)	$95 - \begin{smallmatrix} 0 \\ 0.035 \end{smallmatrix}$ (3.74 - 0.0014)	100 (3.94)	3 (0.12)	3 (0.12)	10 (0.39)	130 (5.12)	45 (1.77)	7 (0.28)	$24 - \begin{smallmatrix} 0 \\ 0.013 \end{smallmatrix}$ (0.94 - 0.0005)	30 (1.18)	40 (1.57)	6.2 (13.66)
20ASA	115 (4.53)	$95 - \begin{smallmatrix} 0 \\ 0.035 \end{smallmatrix}$ (3.74 - 0.0014)	100 (3.94)	3 (0.12)	3 (0.12)	10 (0.39)	130 (5.12)	45 (1.77)	7 (0.28)	$24 - \begin{smallmatrix} 0 \\ 0.013 \end{smallmatrix}$ (0.94 - 0.0005)	30 (1.18)	40 (1.57)	7.4 (16.31)
30ASA	145 (5.71)	$110 - \begin{smallmatrix} 0 \\ 0.035 \end{smallmatrix}$ (4.33 - 0.0014)	130 (5.12)	6 (0.24)	6 (0.24)	12 (0.47)	165 (6.50)	45 (1.77)	9 (0.35)	$28 - \begin{smallmatrix} 0 \\ 0.013 \end{smallmatrix}$ (1.10 - 0.0005)	30 (1.18)	55 (2.17)	11.5 (25.35)
40ASA	145 (5.71)	$110 - \begin{smallmatrix} 0 \\ 0.035 \end{smallmatrix}$ (4.33 - 0.0014)	130 (5.12)	6 (0.24)	6 (0.24)	12 (0.47)	165 (6.50)	45 (1.77)	9 (0.35)	$28 - \begin{smallmatrix} 0 \\ 0.013 \end{smallmatrix}$ (1.10 - 0.0005)	30 (1.18)	55 (2.17)	14.5 (31.96)
50ASA	145 (5.71)	$110 - \begin{smallmatrix} 0 \\ 0.035 \end{smallmatrix}$ (4.33 - 0.0014)	130 (5.12)	6 (0.24)	6 (0.24)	12 (0.47)	165 (6.50)	45 (1.77)	9 (0.35)	$28 - \begin{smallmatrix} 0 \\ 0.013 \end{smallmatrix}$ (1.10 - 0.0005)	30 (1.18)	55 (2.17)	17.5 (38.57)

Note: An absolute encoder (15-bit : 8192 P/R) is used as a detector.

● Connector Wiring on Detector End

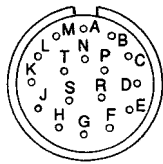

Receptacle: MS3102A20-29P

Plug (To be prepared by customer) (L type): MS3108B20-29S or
(Straight type) MS3106B20-29S

Cable Clamp: (To be prepared by customer) MS3057-12A

A	A channel output	K	---
B	\bar{A} channel output	L	---
C	B channel output	M	---
D	\bar{B} channel output	N	---
E	Z (C) channel output	P	---
F	\bar{Z} (\bar{C}) channel output	R	Reset
G	0 V	S	0 V (battery)
H	+5 VDC	T	3.6 V (battery)
J	FG (Frame Ground)		

6.4.1 Servomotor Dimensional Drawings

- Note: 1. Terminals K to P are not used. Do not connect anything.
 2. Receptacle, plug and cable clamp are common regardless of motor capacity.

● Connector Wiring on Motor End

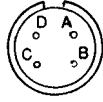

A	Phase U
B	Phase V
C	Phase W
D	Ground terminal

Note: Receptacle, plug and cable clamp differ depending on the capacity. Refer to *Connectors on Detector and Motor Ends* (page 6 -127).

With Absolute Encoder (15-bit : 8192 P/R) and Brake

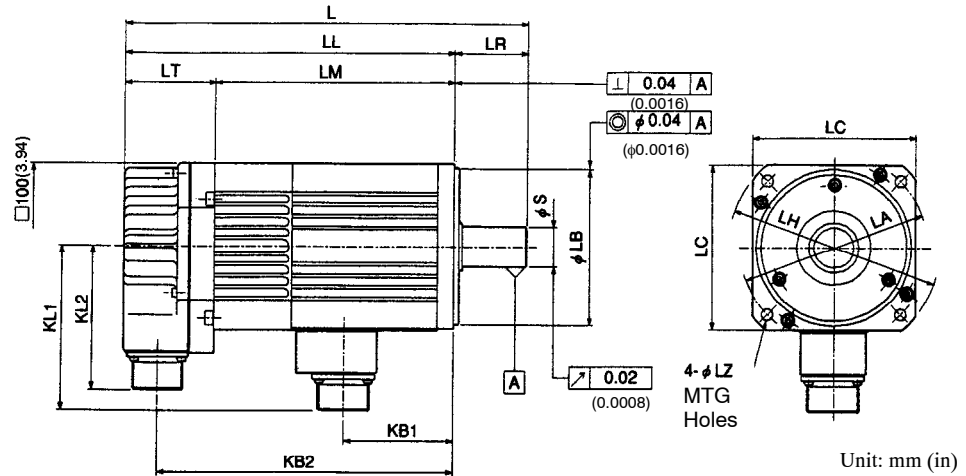

Detailed View of Shaft End

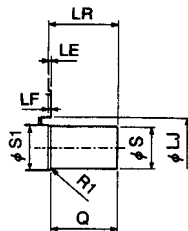

Unit: mm (in)

Model SGMS-	L	LL	LM	LR	LT	KB1	KB2	KL1	KL2
10ASAAB	252 (9.92)	207 (8.15)	147 (5.79)	45 (1.77)	60 (2.36)	67 (2.64)	186 (7.32)	100 (3.94)	87 (3.43)
15ASAAB	278 (10.94)	233 (9.17)	173 (6.81)	45 (1.77)	60 (2.36)	93 (3.66)	212 (8.35)	100 (3.94)	87 (3.43)
20ASAAB	301 (11.85)	256 (10.08)	196 (7.72)	45 (1.77)	60 (2.36)	116 (4.57)	235 (9.25)	100 (3.94)	87 (3.43)

Unit: mm (in)

Model SGMS-	L	LL	LM	LR	LT	KB1	KB2	KL1	KL2
30ASAAB	314 (12.36)	251 (9.88)	191 (7.52)	63 (2.48)	60 (2.36)	113 (4.45)	230 (9.06)	119 (4.69)	87 (3.43)
40ASAAB	350 (13.78)	288 (11.34)	228 (8.98)	63 (2.48)	60 (2.36)	150 (5.91)	267 (10.51)	119 (4.69)	87 (3.43)
50ASAAB	391 (15.39)	328 (12.91)	268 (10.55)	63 (2.48)	60 (2.36)	190 (7.48)	307 (12.09)	119 (4.69)	87 (3.43)

Model SGMS-	Flange Dimensions									Shaft End Dimensions			Approx. Mass kg (lb)
	LA	LB	LC	LE	LF	LG	LH	LJ	LZ	S	S1	Q	
10ASAAB	115 (4.53)	95 ⁰ - 0.035 (3.74 - 0.0014)	100 (3.94)	3 (0.12)	3 (0.12)	10 (0.39)	130 (5.12)	45 (1.77)	7 (0.28)	24 ⁰ - 0.013 (0.94 - 0.0005)	30 (1.18)	40 (1.57)	6.5 (14.33)
15ASAAB	115 (4.53)	95 ⁰ - 0.035 (3.74 - 0.0014)	100 (3.94)	3 (0.12)	3 (0.12)	10 (0.39)	130 (5.12)	45 (1.77)	7 (0.28)	24 ⁰ - 0.013 (0.94 - 0.0005)	30 (1.18)	40 (1.57)	8.0 (17.63)
20ASAAB	115 (4.53)	95 ⁰ - 0.035 (3.74 - 0.0014)	100 (3.94)	3 (0.12)	3 (0.12)	10 (0.39)	130 (5.12)	45 (1.77)	7 (0.28)	24 ⁰ - 0.013 (0.94 - 0.0005)	30 (1.18)	40 (1.57)	9.0 (19.84)
30ASAAB	145 (5.71)	110 ⁰ - 0.035 (4.33 - 0.0014)	130 (5.12)	6 (0.24)	6 (0.24)	12 (0.47)	165 (6.50)	45 (1.77)	9 (0.35)	28 ⁰ - 0.013 (1.10 - 0.0005)	30 (1.18)	55 (2.17)	14.5 (31.96)
40ASAAB	145 (5.71)	110 ⁰ - 0.035 (4.33 - 0.0014)	130 (5.12)	6 (0.24)	6 (0.24)	12 (0.47)	165 (6.50)	45 (1.77)	9 (0.35)	28 ⁰ - 0.013 (1.10 - 0.0005)	30 (1.18)	55 (2.17)	17.5 (38.57)
50ASAAB	145 (5.71)	110 ⁰ - 0.035 (4.33 - 0.0014)	130 (5.12)	6 (0.24)	6 (0.24)	12 (0.47)	165 (6.50)	45 (1.77)	9 (0.35)	28 ⁰ - 0.013 (1.10 - 0.0005)	30 (1.18)	55 (2.17)	20.5 (45.18)

Note: An absolute encoder (15-bit : 8192 P/R) is used as a detector.

● Connector Wiring on Motor End

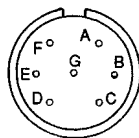

A	Phase U	E	Brake terminal
B	Phase V	F	Brake terminal
C	Phase W	G	---
D	Frame ground (FG)		

■ **SGMD-□□A Servomotors**

With Incremental Encoder (4096 P/R)

With Incremental Encoder (4096 P/R) and Brake

The dimensional drawing is the same for these types. Only approximate mass differs.

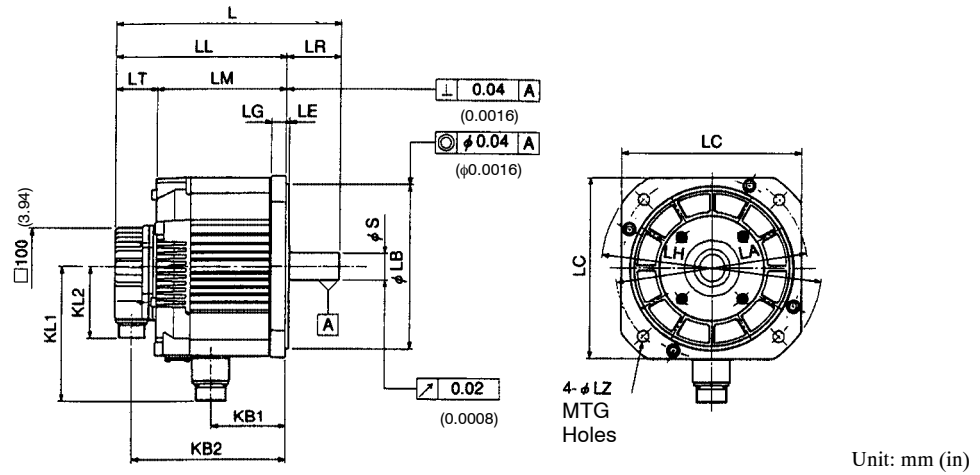

Detailed View of Shaft End

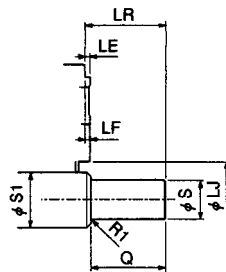

6

Model SGMD-	L	LL	LM	LR	LT	KB1	KB2	KL1	KL2
22A6A	242 (9.53)	187 (7.36)	144 (5.67)	55 (2.17)	43 (1.69)	70 (2.76)	166 (6.54)	165 (6.50)	88 (3.46)
32A6A	254 (10.00)	199 (7.83)	156 (6.14)	55 (2.17)	43 (1.69)	82 (3.23)	178 (7.01)	165 (6.50)	88 (3.46)
40A6A	274 (10.79)	209 (8.23)	166 (6.54)	65 (2.56)	43 (1.69)	92 (3.62)	188 (7.40)	165 (6.50)	88 (3.46)

Unit: mm (in)

Model SGMD-	Flange Dimensions									Shaft End Dimensions			Approx. Mass kg (lb)	
	LA	LB	LC	LE	LF	LG	LH	LJ	LZ	S	S1	Q	without brake	with brake
22A6A	235 (9.25)	$200 - \begin{smallmatrix} 0 \\ 0.046 \end{smallmatrix}$ (7.87 - 0.0018)	220 (8.66)	4 (0.16)	4 (0.16)	18 (0.71)	270 (10.63)	62 (2.44)	13.5 (0.53)	$28 - \begin{smallmatrix} 0 \\ 0.013 \end{smallmatrix}$ (1.10 - 0.0005)	45 (1.77)	50 (1.97)	15.5 (34.16)	20.5 (45.18)
32A6A	235 (9.25)	$200 - \begin{smallmatrix} 0 \\ 0.046 \end{smallmatrix}$ (7.87 - 0.0018)	220 (8.66)	4 (0.16)	4 (0.16)	18 (0.71)	270 (10.63)	62 (2.44)	13.5 (0.53)	$28 - \begin{smallmatrix} 0 \\ 0.013 \end{smallmatrix}$ (1.10 - 0.0005)	45 (1.77)	50 (1.97)	18.5 (40.77)	23.5 (51.79)
40A6A	235 (9.25)	$200 - \begin{smallmatrix} 0 \\ 0.046 \end{smallmatrix}$ (7.87 - 0.0018)	220 (8.66)	4 (0.16)	4 (0.16)	18 (0.71)	270 (10.63)	62 (2.44)	13.5 (0.53)	$32 - \begin{smallmatrix} 0 \\ 0.016 \end{smallmatrix}$ (1.26 - 0.0006)	45 (1.77)	60 (2.36)	21 (46.28)	26 (57.30)

Note: 1. An incremental encoder (4096 P/R) is used as a detector.

2. For SGMD Servomotors with brake, the product model number ends with "AB".

● Connector Wiring on Detector End

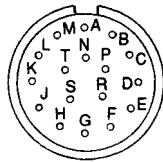

Receptacle: MS3102A20-29P

Plug (To be prepared by customer) (L type): MS3108B20-29S or
(Straight type) MS3106B20-29S

Cable Clamp: (To be prepared by customer) MS3057-12A

A	A channel output	K	---
B	\bar{A} channel output	L	---
C	B channel output	M	---
D	\bar{B} channel output	N	---
E	C channel output	P	---
F	\bar{C} channel output	R	---
G	0 V	S	---
H	+5 VDC	T	---
J	FG (Frame Ground)		

Note: 1. Terminals K to T are not used.

2. Receptacle, plug and cable clamp are common regardless of motor capacity.

• Connector Wiring on Motor End

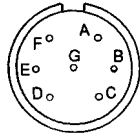

Receptacle: MS3102A24-10P
 Plug (To be prepared by customer) (L type): MS3108B24-10S or
 (Straight type) MS3106B24-10S
 Cable Clamp: (To be prepared by customer) MS3057-16A

A	Phase U	E	Brake terminal
B	Phase V	F	Brake terminal
C	Phase W	G	---
D	Frame ground (FG)		

Note: E and F are only used with the brake.

With Absolute Encoder (12-bit: 1024 P/R)

With Absolute Encoder (12-bit: 1024 P/R) and Brake

These dimensional drawing is the same for these types. Only approximate mass differs.

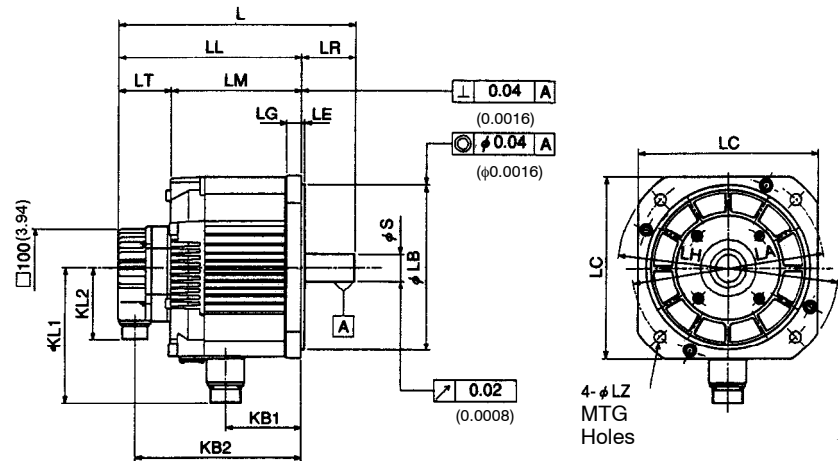

4-φLZ
 MTG
 Holes

Unit: mm (in)

Detailed View of Shaft End

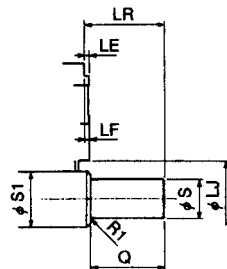

Unit: mm (in)

Model SGMD-	L	LL	LM	LR	LT	KB1	KB2	KL1	KL2
22AWA	256 (10.08)	201 (7.91)	144 (5.67)	55 (2.17)	57 (2.24)	70 (2.76)	180 (7.09)	165 (6.50)	88 (3.46)
32AWA	268 (10.55)	213 (8.39)	156 (6.14)	55 (2.17)	57 (2.24)	82 (3.23)	192 (7.56)	165 (6.50)	88 (3.46)
40AWA	288 (11.34)	223 (8.78)	166 (6.54)	65 (2.56)	57 (2.24)	92 (3.62)	202 (7.95)	165 (6.50)	88 (3.46)

Model SGMD-	Flange Dimensions									Shaft End Dimensions			Approx. Mass kg (lb)	
	LA	LB	LC	LE	LF	LG	LH	LJ	LZ	S	S1	Q	without brake	with brake
22AWA	235 (9.25)	$200 - \begin{smallmatrix} 0 \\ 0.046 \end{smallmatrix}$ $(7.87 - 0.0018)$	220 (8.66)	4 (0.16)	4 (0.16)	18 (0.71)	270 (10.63)	62 (2.44)	13.5 (0.53)	$28 - \begin{smallmatrix} 0 \\ 0.013 \end{smallmatrix}$ $(1.10 - 0.0005)$	45 (1.77)	50 (1.97)	15.5 (34.16)	20.5 (45.18)
32AWA	235 (9.25)	$200 - \begin{smallmatrix} 0 \\ 0.046 \end{smallmatrix}$ $(7.87 - 0.0018)$	220 (8.66)	4 (0.16)	4 (0.16)	18 (0.71)	270 (10.63)	62 (2.44)	13.5 (0.53)	$28 - \begin{smallmatrix} 0 \\ 0.013 \end{smallmatrix}$ $(1.10 - 0.0005)$	45 (1.77)	50 (1.97)	18.5 (40.77)	23.5 (51.79)
40AWA	235 (9.25)	$200 - \begin{smallmatrix} 0 \\ 0.046 \end{smallmatrix}$ $(7.87 - 0.0018)$	220 (8.66)	4 (0.16)	4 (0.16)	18 (0.71)	270 (10.63)	62 (2.44)	13.5 (0.53)	$32 - \begin{smallmatrix} 0 \\ 0.016 \end{smallmatrix}$ $(1.26 - 0.0006)$	45 (1.77)	60 (2.36)	21 (46.28)	26.5 (58.41)

Note: 1. An absolute encoder (12-bit : 1024 P/R) is used as a detector.

2. For SGMD Servomotors with brake, the product model number ends with "AB".

● Connector Wiring on Detector End

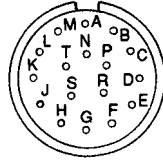

Receptacle: MS3102A20-29P
 Plug (To be prepared by customer) (L type): MS3108B20-29S or (Straight type) MS3106B20-29S
 Cable Clamp: (To be prepared by customer) MS3057-12A

A	A channel output	K	S channel output
B	\bar{A} channel output	L	\bar{S} channel output
C	B channel output	M	---
D	\bar{B} channel output	N	---
E	Z (C) channel output	P	---
F	\bar{Z} (\bar{C}) channel output	R	Reset
G	0 V	S	0 V (battery)
H	+5 VDC	T	3.6 V (battery)
J	FG (Frame Ground)		

Note: 1. Terminals M to P are not used. Do not connect anything.
 2. Receptacle, plug and cable clamp are common regardless of motor capacity.

● Connector Wiring on Motor End

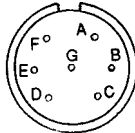

Receptacle: MS3102A24-10P
 Plug (To be prepared by customer) (L type): MS3108B24-10S or (Straight type) MS3106B24-10S
 Cable Clamp: (To be prepared by customer) MS3057-16A

A	Phase U	E	Brake terminal
B	Phase V	F	Brake terminal
C	Phase W	G	---
D	Frame ground (FG)		

Note: E and F are only used with the brake.

SGM Servomotors

With Incremental Encoder (2048 P/R) and without Brake

- 200 W, 400 W

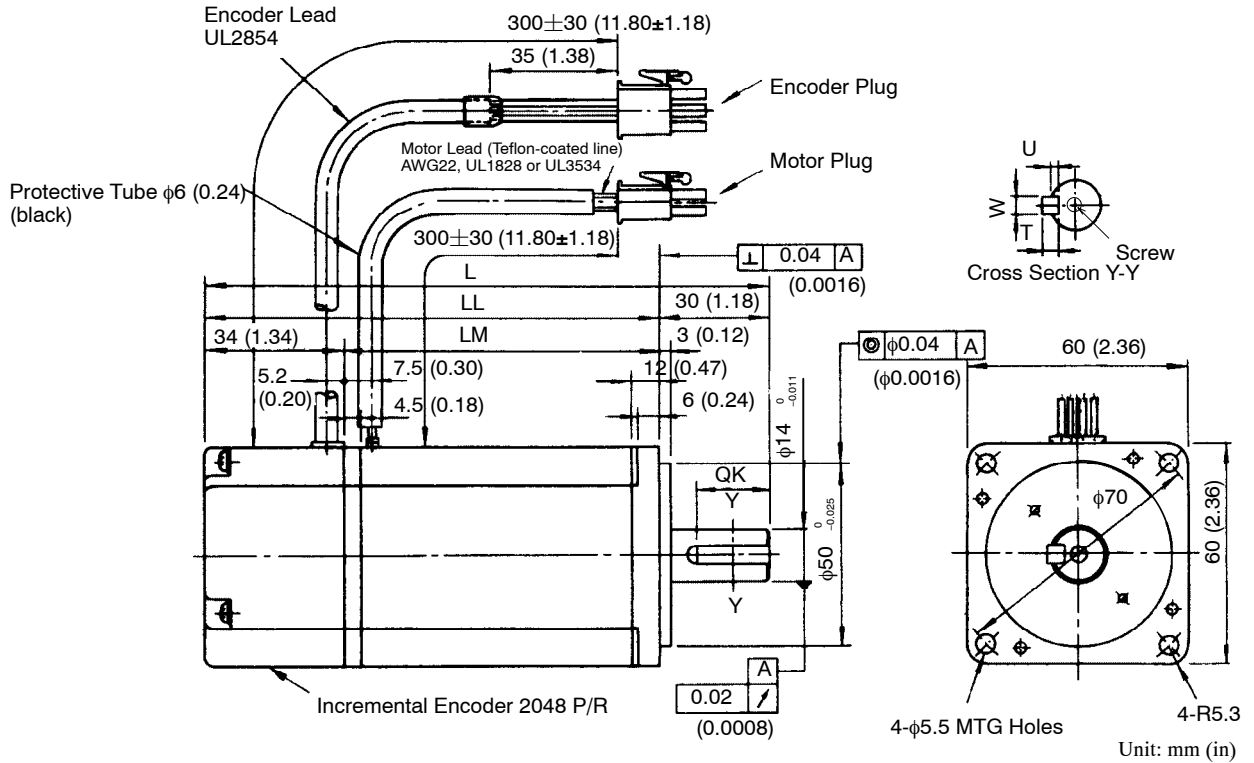

Model SGM-	L	LL	LM	QK	U	W	T	Output W (HP)	Approx. Mass kg (lb)	Allowable Radial Load N (lb)	Allowable Thrust Load N (lb)
02A312	126.5 (4.98)	96.5 (3.80)	62.5 (2.46)	No key				200 (0.272)	1.1 (2.425)	245 (55)	74 (16)
02A314				20 (0.79)	3 (0.12)	5 (0.20)	5 (0.20)				
04A312	154.5 (6.08)	124.5 (4.90)	90.5 (3.56)	No key				400 (0.54)	1.7 (3.745)	245 (55)	74 (16)
04A314				20 (0.79)	3 (0.12)	5 (0.20)	5 (0.20)				

Note: 1. An incremental encoder (2048 P/R) is used as a detector.

2. Model 0□A314 is fitted with a key. The keyway conforms to JIS B 1301-1976 (precision). A parallel key is supplied.

3. The quoted allowable radial load is the value at a position 25 mm (0.98 in.) from the motor mounting surface.

6.4.1 Servomotor Dimensional Drawings

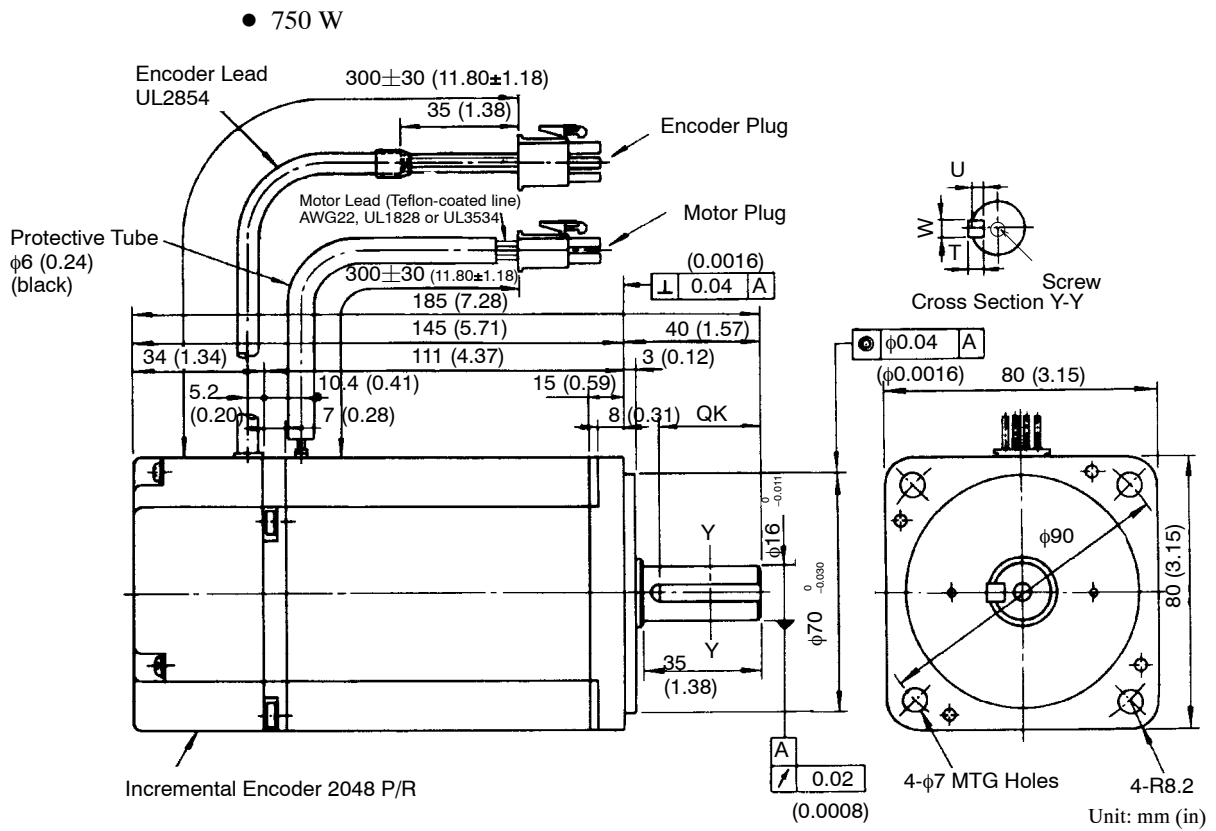

Model SGM-	QK	U	W	T	Output W (HP)	Approx. Mass kg (lb)	Allowable Radial Load N (lb)	Allowable Thrust Load N (lb)
08A312	No key				750 (1.01)	3.4 (7.496)	392 (88.1)	147 (33.0)
08A314	30 (1.18)	3 (0.12)	5 (0.20)	5 (0.20)				

Note: 1. An incremental encoder (2048 P/R) is used as a detector.

2. Model 08A314 is fitted with a key. The keyway conforms to JIS B 1301-1976 (precision). A parallel key is supplied.

3. The quoted allowable radial load is the value at a position 35 mm (1.38 in.) from the motor mounting surface.

- Details of Motor and Encoder Plugs (200 W, 400 W, 750 W)

Motor Plug

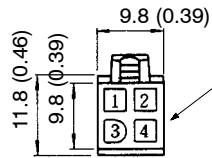

Plug: 172167-1 (Made by AMP)
 Pin: 170360-1 or 170364-1
 Connected to
 Cap: 172159-1
 Socket: 170362-1 or 170366-1

- Motor Wiring Specifications

1	Phase U	Red
2	Phase V	White
3	Phase W	Blue
4	FG (Frame Ground)	Green

Encoder Plug

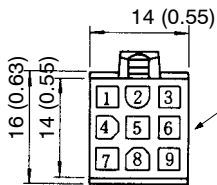

Plug: 172169-1 (Made by AMP)
 Pin: 170359-1 or 170363-1
 Connected to
 Cap: 172161-1
 Socket: 170361-1 or 170365-1

- Incremental Encoder Wiring Specifications

1	A channel output	Blue
2	\bar{A} channel output	Blue/Black
3	B channel output	Yellow
4	\bar{B} channel output	Yellow/Black
5	C channel output	Green
6	\bar{C} channel output	Green/Black
7	0 V (Power Supply)	Gray
8	+5 V (Power Supply)	Red
9	FG (Frame Ground)	Orange

With Incremental Encoder (2048 P/R) and Brake

- 200 W, 400 W

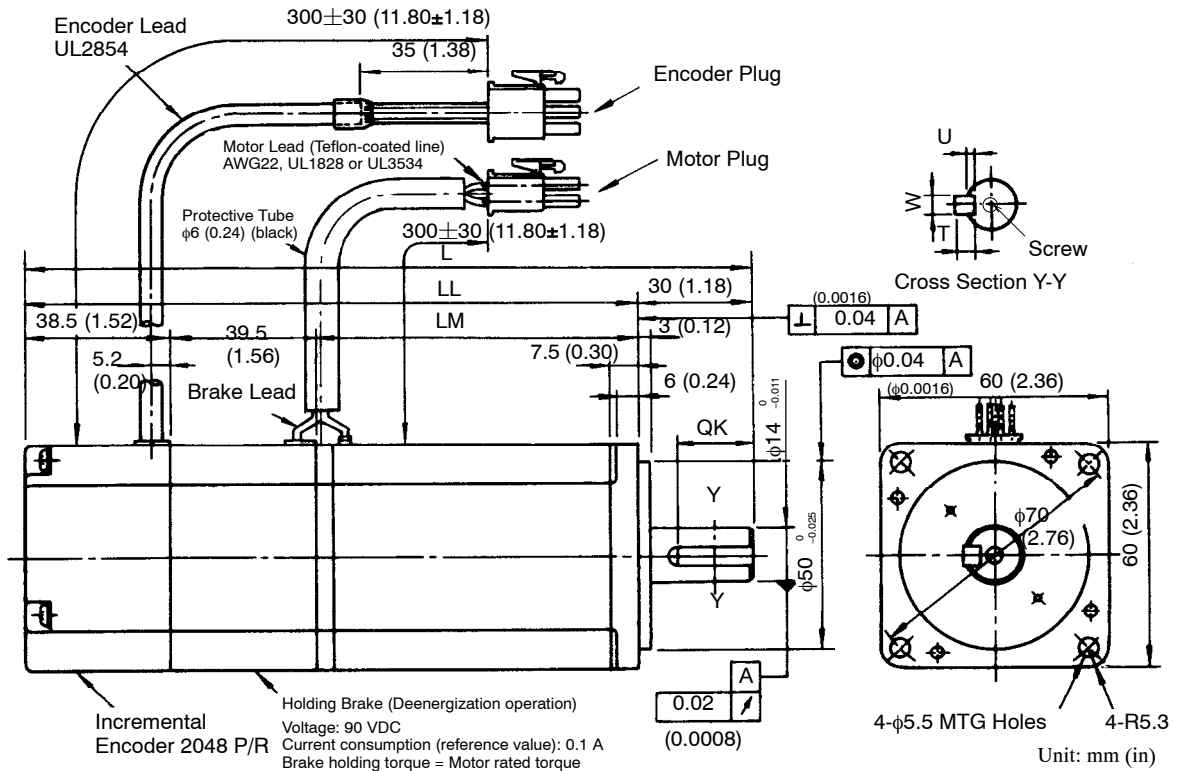

Model SGM-	L	LL	LM	QK	U	W	T	Output W (HP)	Approx. Mass kg (lb)	Allowable Radial Load N (lb)	Allowable Thrust Load N (lb)
02A312B	166.0 (6.54)	136.0 (5.35)	62.5 (2.46)	No key				200 (0.272)	1.6 (3.527)	245 (55.1)	74 (16.6)
02A314B				20 (0.79)	3 (0.12)	5 (0.20)	5 (0.20)				
04A312B	194.0 (7.64)	164.0 (6.46)	90.5 (3.56)	No key				400 (0.54)	2.2 (4.850)	245 (55.1)	74 (16.6)
04A314B				20 (0.79)	3 (0.12)	5 (0.20)	5 (0.20)				

- Note: 1. An incremental encoder (2048 P/R) is used as a detector.
2. Model 0□A314B is fitted with a key. The keyway conforms to JIS B 1301-1976 (precision). A parallel key is supplied.
3. The quoted allowable radial load is the value at a position 25 mm (0.98 in.) from the motor mounting surface.
4. Use the electromagnetic brake to hold the load in position only, and do not use it to stop the motor.

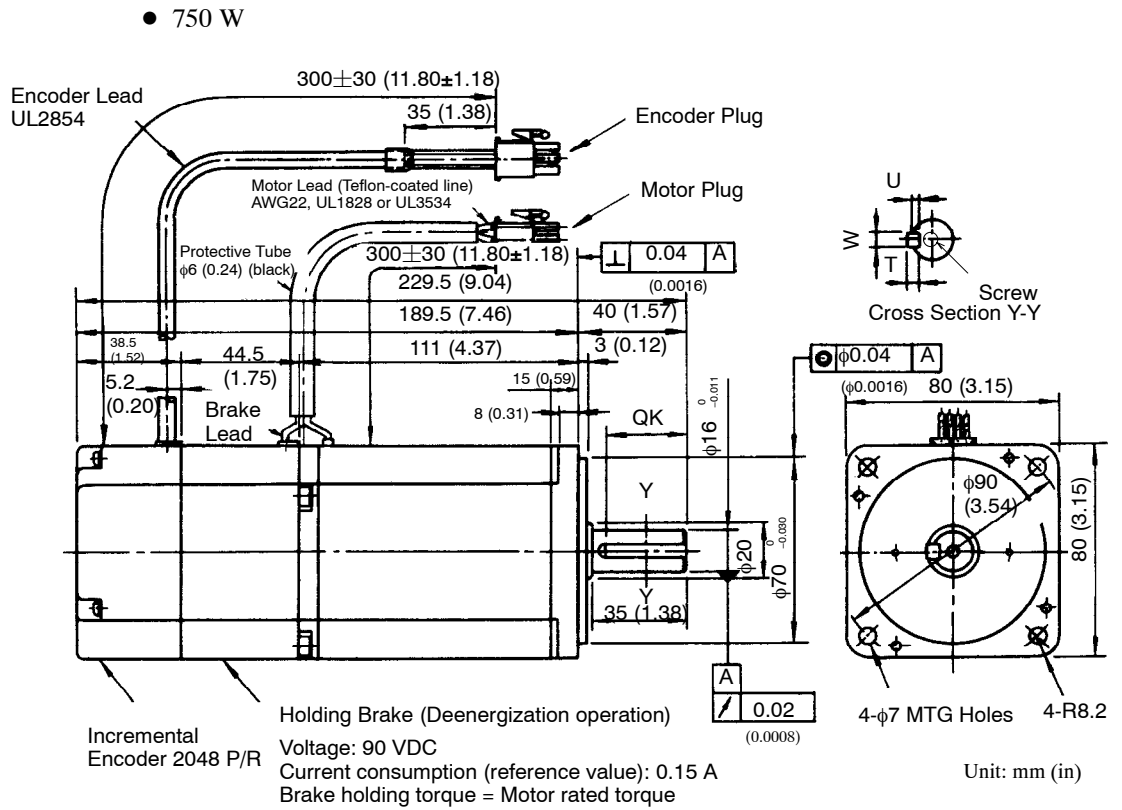

Model SGM-	QK	U	W	T	Output W (HP)	Approx. Mass kg (lb)	Allowable Radial Load N (lb)	Allowable Thrust Load N (lb)
08A312B	No key				750 (1.01)	4.3 (9.480)	392 (88.1)	147 (33.0)
08A314B	30 (1.18)	3 (0.12)	5 (0.20)	5 (0.20)				

Note: 1. An incremental encoder (2048 P/R) is used as a detector.

- Model 08A314B is fitted with a key. The keyway conforms to JIS B 1301-1976 (precision). A parallel key is supplied.
- The quoted allowable radial load is the value at a position 35 mm (1.38 in.) from the motor mounting surface.
- Use the electromagnetic brake to hold the load in position only, and do not use it to stop the motor.

● Details of Motor and Encoder Plugs (200 W, 400 W, 750 W)

Motor Plug

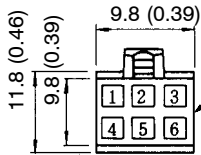

Plug: 172168-1 (Made by AMP)
 Pin: 170360-1 or 170364-1
 Connected to
 Cap: 172160-1
 Socket: 170362-1 or 170366-1

● Motor Wiring Specifications

1	Phase U	Red
2	Phase V	White
3	Phase W	Blue
4	FG (Frame Ground)	Green
5	Brake terminal	Red
6	Brake terminal	Black

Encoder Plug

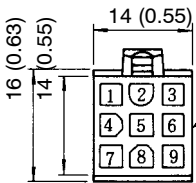

Plug: 172169-1 (Made by AMP)
 Pin: 170359-1 or 170363-1
 Connected to
 Cap: 172161-1
 Socket: 170361-1 or 170365-1

● Incremental Encoder Wiring Specifications

1	A channel output	Blue
2	\bar{A} channel output	Blue/Black
3	B channel output	Yellow
4	\bar{B} channel output	Yellow/Black
5	C channel output	Green
6	\bar{C} channel output	Green/Black
7	0 V (Power Supply)	Gray
8	+5 V (Power Supply)	Red
9	FG (Frame Ground)	Orange

With Absolute Encoder (12-bit: 1024 P/R) and without Brake

- 200 W, 400 W

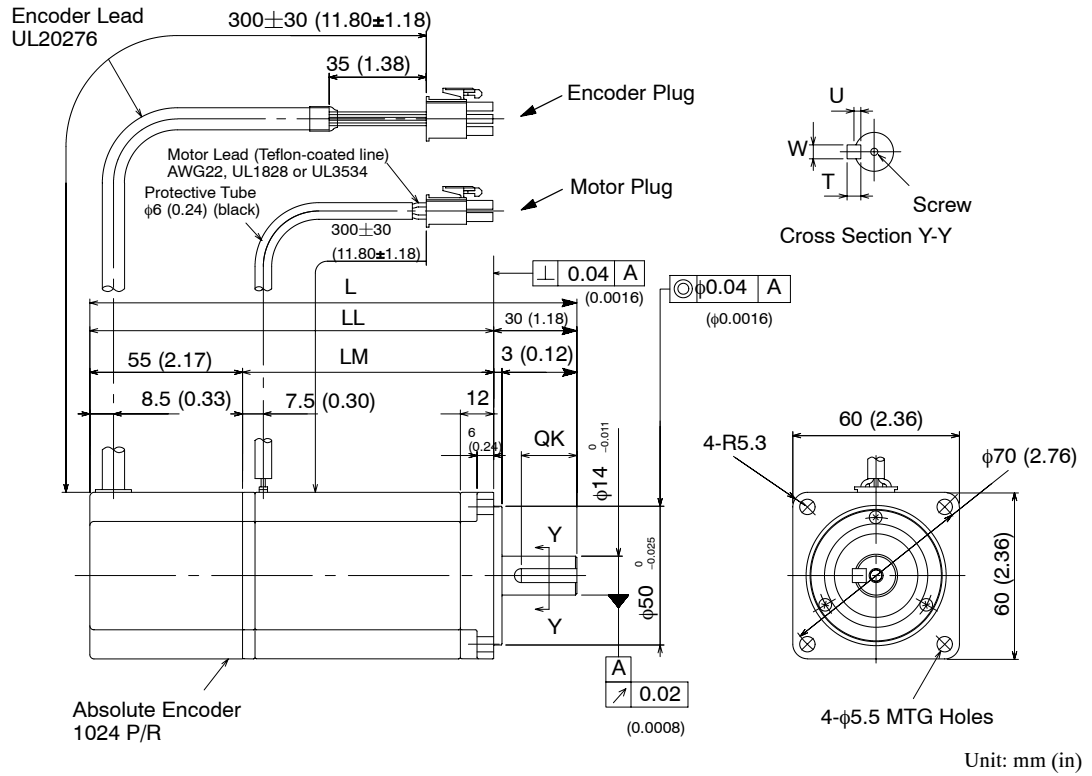

Model SGM-	L	LL	LM	QK	U	W	T	Screw Dimensions	Output W (HP)	Approx. Mass kg (lb)	Allowable Radial Load N (lb)	Allowable Thrust Load N (lb)
02AW 12	149.5 (5.89)	119.5 (4.70)	58.0 (2.28)	No key				No screw	200 (0.272)	1.2 (2.646)	196 (44.1)	49 (11.0)
02AW 14				20 (0.79)	3 (0.12)	5 (0.20)	5 (0.20)					
04AW 12	175.5 (6.91)	145.5 (5.73)	90.5 (3.56)	No key				M5 Depth: 8 (0.31)	400 (0.54)	1.8 (3.968)	245 (55.1)	74 (16.6)
04AW 14				20 (0.79)	3 (0.12)	5 (0.20)	5 (0.20)					
04AW 16												

- Note: 1. An absolute encoder (12-bit: 1024 P/R) is used as a detector.
2. Model 0□AW16 is fitted with a key. The keyway conforms to JIS B 1301-1976 (precision). A parallel key is supplied.
3. The quoted allowable radial load is the value at a position 25 mm (0.98 in.) from the motor mounting surface.

6.4.1 Servomotor Dimensional Drawings

• 750 W

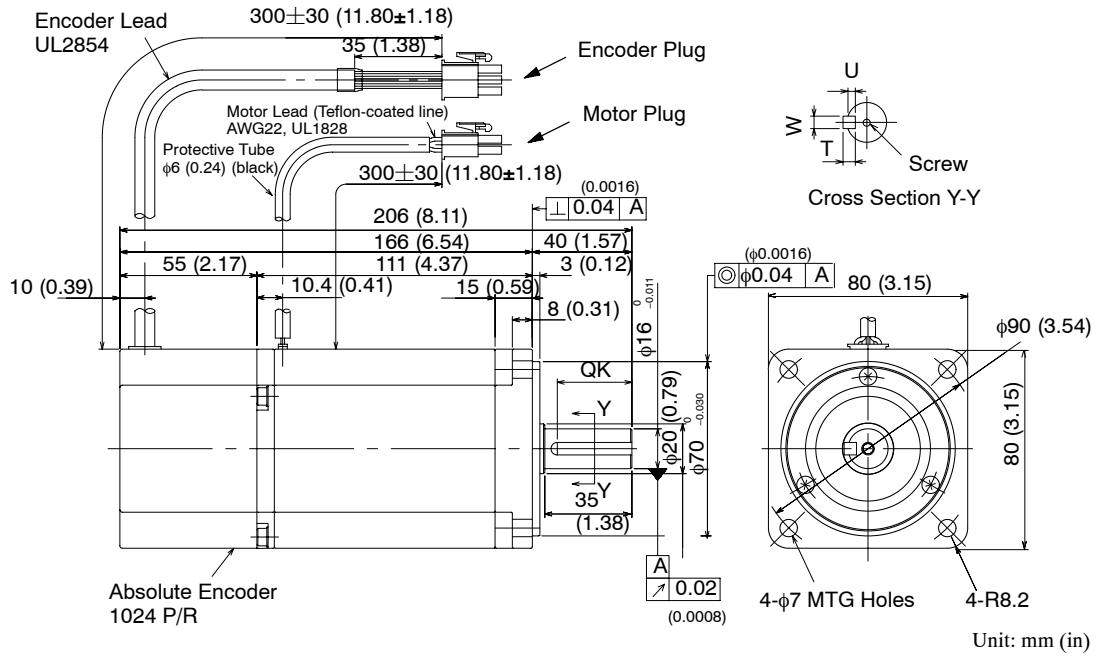

Unit: mm (in)

Model SGM-	QK	U	W	T	Screw Dimensions	Output W (HP)	Approx. Mass kg (lb)	Allowable Radial Load N (lb)	Allowable Thrust Load N (lb)
08AW12	No key				No screw	750 (1.01)	3.5 (7.716)	392 (88.1)	147 (33.0)
08AW14	30 (1.18)	3 (0.12)	5 (0.20)	5 (0.20)					
08AW16				M5 Depth: 8 (0.31)					

Note: 1. An absolute encoder (12-bit: 1024 P/R) is used as a detector.

2. Models 08AW14 and 08AW16 are fitted with a key. The keyway conforms to JIS B 1301-1976 (precision). A parallel key is supplied.
3. The quoted allowable radial load is the value at a position 35 mm (1.38 in.) from the motor mounting surface.
4. Model 08AW16 is fitted with a tapped hole on the end of the shaft (M5 × 8L).

- Details of Motor and Encoder Plugs (200 W, 400 W, 750 W)

Motor Plug



Plug: 172167-1 (Made by AMP)
 Pin: 170360-1 or 179364-1
 Connected to
 Cap: 172159-1
 Socket: 170362-1 or 170366-1

- Motor Wiring Specifications

1	Phase U	Red
2	Phase V	White
3	Phase W	Blue
4	FG	Green

Encoder Plug

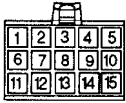

Plug: 172171-1 (Made by AMP)
 Pin: 170359-1 or 170363-1
 Connected to
 Cap: 172163-1
 Socket: 170361-1 or 170365-1

- Absolute Encoder Wiring Specifications

1	A channel output	Blue
2	\bar{A} channel output	White/Blue
3	B channel output	Yellow
4	\bar{B} channel output	White/Yellow
5	Z channel output	Green
6	\bar{Z} channel output	White/Green
7	0 V (Power Supply)	Black
8	+5 V (Power Supply)	Red
9	FG (Frame Ground)	Green/Yellow
10	S channel output	Purple
11	\bar{S} channel output	White/Purple
(12)*	(Capacitor Reset)	(Gray)
13	Reset	White/Gray
14	0 V (battery)	White/Orange
15	3.6V(battery)	Orange

* Terminal to discharge capacitor at time of shipping. Do not use.

With Absolute Encoder (12-bit : 1024 P/R) and Brake

- 200 W, 400 W

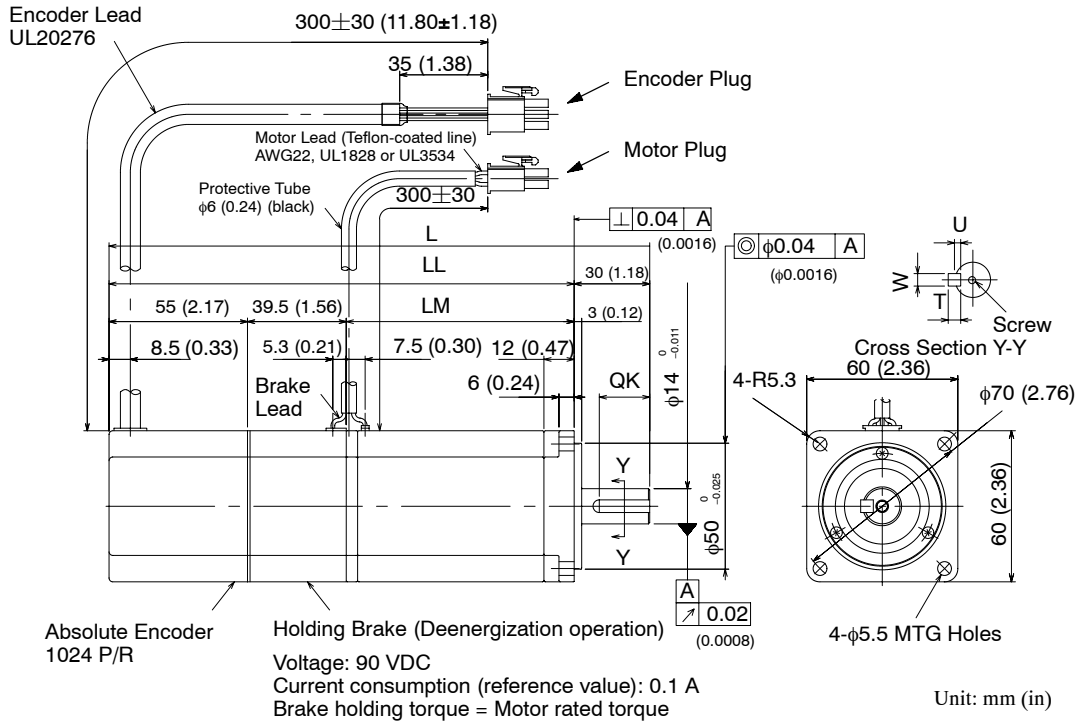

6

Model SGM-	L	LL	LM	QK	U	W	T	Screw Dimensions	Output W (HP)	Approx. Mass kg (lb)	Allowable Radial Load N (lb)	Allowable Thrust Load N (lb)
02AW 12B	189.0 (7.44)	159.0 (6.26)	58.0 (2.28)	No key				No screw	200 (0.272)	1.7 (3.745)	196 (44.1)	49 (11.0)
02AW 14B				20 (0.79)	3 (0.12)	5 (0.20)	5 (0.20)					
04AW 12B	215.0 (8.46)	185.0 (7.28)	90.5 (3.56)	No key				M5 Depth: 8 (0.31)	400 (0.54)	2.3 (5.071)	245 (55.1)	74 (16.6)
04AW 14B				20 (0.79)	3 (0.12)	5 (0.20)	5 (0.20)					
04AW 16B												

- Note: 1. An absolute encoder (12-bit: 1024 P/R) is used as a detector.
2. Models 0□AW14B and 0□AW16B are fitted with a key. The keyway conforms to JIS B 1301-1976 (precision). A parallel key is supplied.
3. The quoted allowable radial load is the value at a position 25 mm (0.98 in.) from the motor mounting surface.
4. Use the electromagnetic brake to hold the load in position only, and do not use it to stop the motor.
5. Model 0□AW16B is fitted with a tapped hole on the end of the shaft (M5 × 8L).

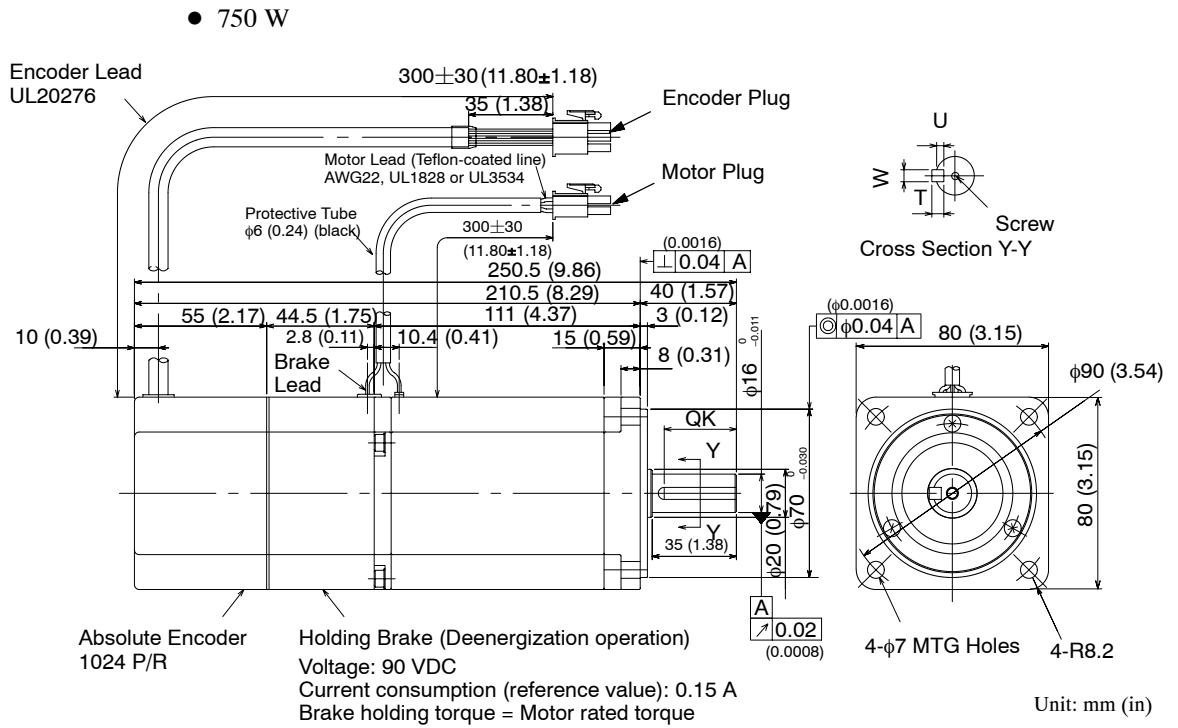

Model SGM-	QK	U	W	T	Screw Dimensions	Output W (HP)	Approx. Mass kg (lb)	Allowable Radial Load N (lb)	Allowable Thrust Load N (lb)
08AW12B	No key				No screw	750 (1.01)	4.5 (9.921)	392 (88.1)	147 (33.0)
08AW14B	30 (1.18)	3 (0.12)	5 (0.20)	5 (0.20)					
08AW16B					M5 Depth: 8 (0.31)				

- Note: 1. An absolute encoder (12-bit: 1024 P/R) is used as a detector.
2. Models 08AW14B and 08AW16B are fitted with a key. The keyway conforms to JIS B 1301-1976 (precision). A parallel key is supplied.
3. The quoted allowable radial load is the value at a position 35 mm (1.38 in.) from the motor mounting surface.
4. Model 08AW16B is fitted with a tapped hole on the end of the shaft (M5 × 8L).

● Details of Motor and Encoder Plugs (200 W, 400 W, 750 W)

Motor Plug



Plug: 172167-1 (Made by AMP)
 Pin: 170360-1 or 179364-1
 Connected to
 Cap: 172159-1
 Socket: 170362-1 or 170366-1

● Motor Wiring Specifications

1	Phase U	Red
2	Phase V	White
3	Phase W	Blue
4	FG	Green

Encoder Plug

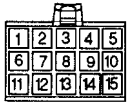

Plug: 172171-1 (Made by AMP)
 Pin: 170359-1 or 170363-1
 Connected to
 Cap: 172163-1
 Socket: 170361-1 or 170365-1

● Absolute Encoder Wiring Specifications

1	A channel output	Blue
2	\bar{A} channel output	White/Blue
3	B channel output	Yellow
4	\bar{B} channel output	White/Yellow
5	Z channel output	Green
6	\bar{Z} channel output	White/Green
7	0 V (Power Supply)	Black
8	+5 V (Power Supply)	Red
9	FG (Frame Ground)	Green/Yellow
10	S channel output	Purple
11	\bar{S} channel output	White/Purple
(12)*	(Capacitor Reset)	(Gray)
13	Reset	White/Gray
14	0 V(battery)	White/Orange
15	3.6 V(battery)	Orange

* Terminal to discharge capacitor at time of shipping. Do not use.

SGMP Servomotors

With Incremental Encoder (2048 P/R)

- 200 W, 400 W

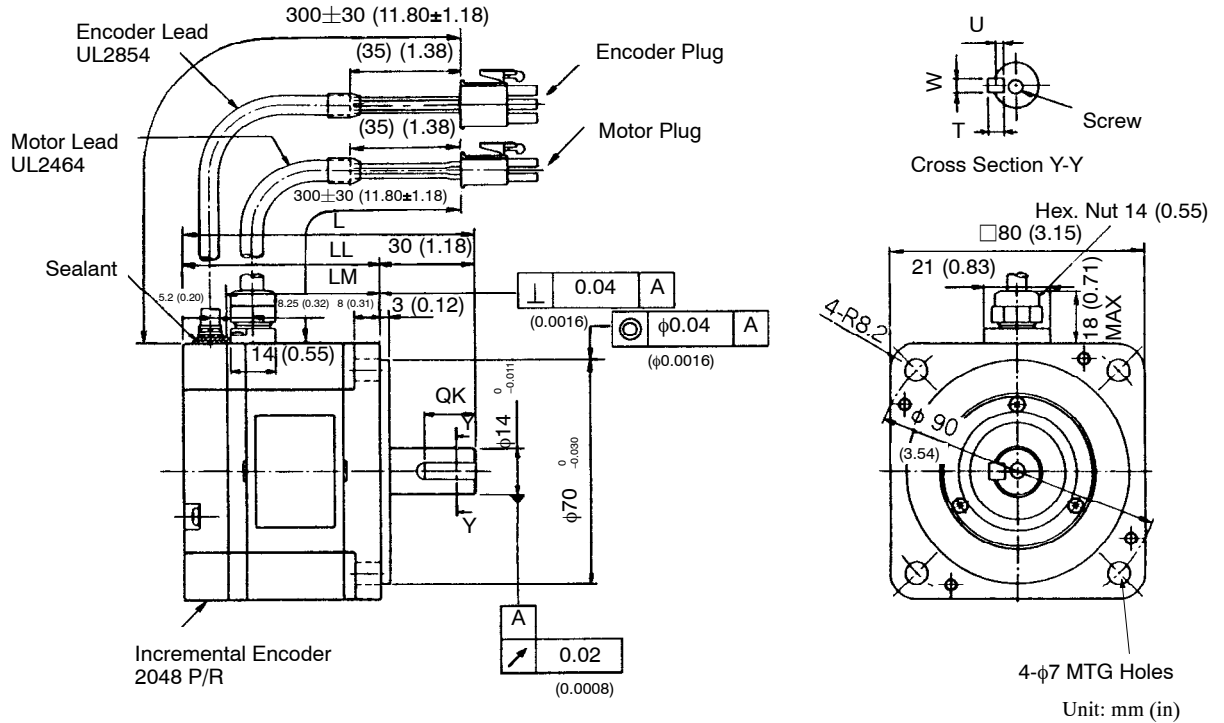

Model SGMP-	L	LL	LM	QK	U	W	T	Screw Dimensions	Output W (HP)	Approx. Mass kg (lb)	Allowable Radial Load N (lb)	Allowable Thrust Load N (lb)
02A312	92 (3.62)	62 (2.44)	48.1 (1.89)	No key				No screw	200 (0.272)	1.4 (3.086)	245 (55.1)	68 (15.3)
02A314			16 (0.63)	3 (0.12)	5 (0.20)	5 (0.20)						
02A316							M5 Depth: 8 (0.31)					
04A312	112 (4.41)	82 (3.23)	68.1 (2.68)	No key				No screw	400 (0.54)	2.1 (4.630)	245 (55.1)	68 (15.3)
04A314			16 (0.63)	3 (0.12)	5 (0.20)	5 (0.20)						
04A316							M5 Depth: 8 (0.31)					

Note: 1. An incremental encoder (2048 P/R) is used as a detector.

2. Models 0□A314 and 0□A316 are fitted with a key. The keyway conforms to JIS B 1301-1976 (precision). A parallel key is supplied.

3. The quoted allowable radial load is the value at a position 25 mm (0.98 in.) from the motor mounting surface.

4. Protective structure: IP55 (excluding connector and side of output shaft).

6.4.1 Servomotor Dimensional Drawings

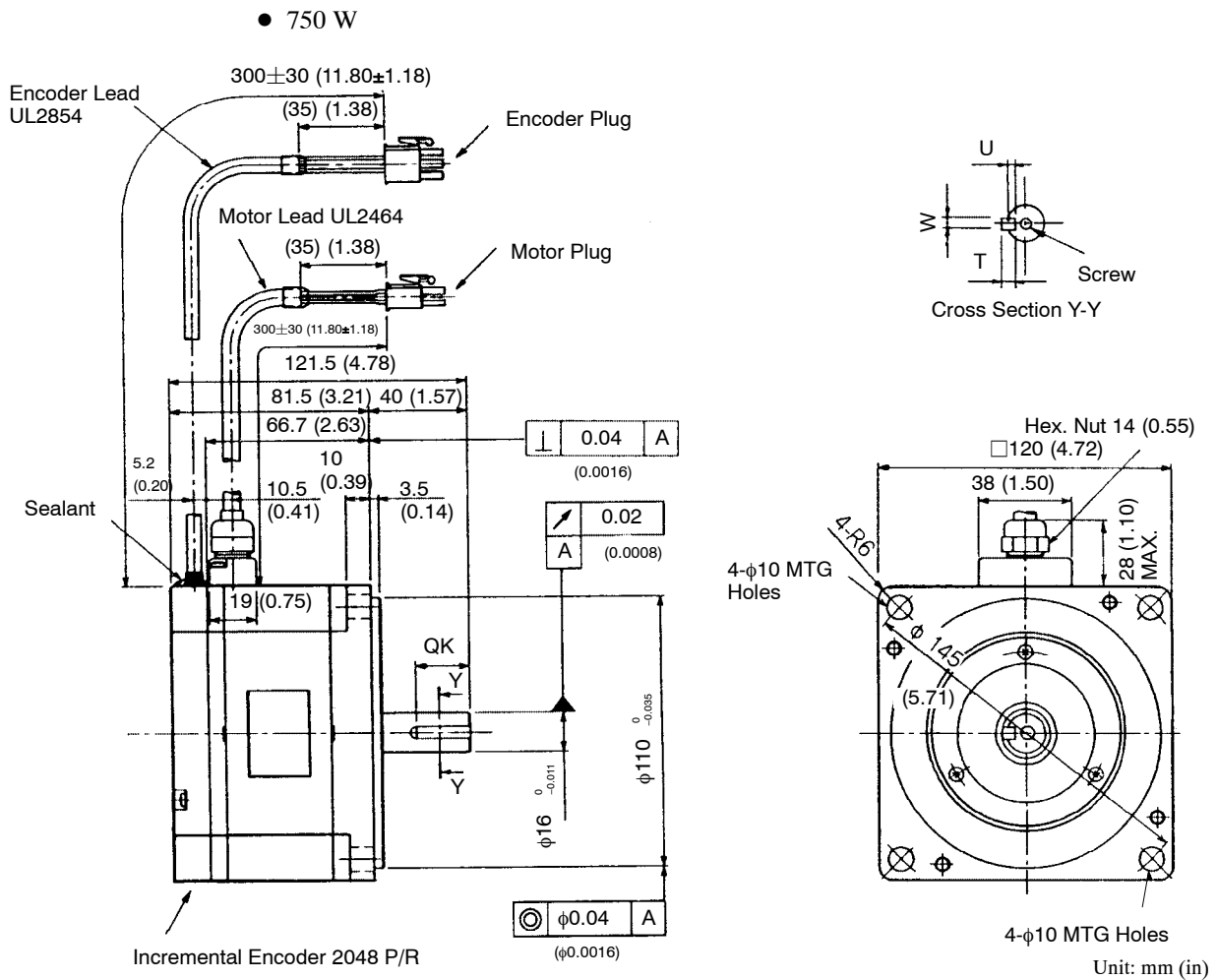

Model SGMP-	QK	U	W	T	Screw Dimensions	Output W (HP)	Approx. Mass kg (lb)	Allowable Radial Load N (lb)	Allowable Thrust Load N (lb)
08A312	No key				No screw	750 (1.01)	4.2 (9.259)	392 (88.1)	147 (33.0)
08A314	22 (0.87)	3 (0.12)	5 (0.20)	5 (0.20)	M5 Depth: 8 (0.31)				
08A316									

Note: 1. An incremental encoder (2048 P/R) is used as a detector.

2. Models 08A314 and 08A316 are fitted with a key. The keyway conforms to JIS B 1301-1976 (precision). A parallel key is supplied.

3. The quoted allowable radial load is the value at a position 35 mm (1.38 in.) from the motor mounting surface.

4. Protective structure: IP55 (excluding connector and side of output shaft).

- Details of Motor and Encoder Plugs (200 W, 400 W, 750 W)

Motor Plug



Plug: 172167-1 (Made by AMP)
 Pin: 170360-1 or 179364-1
 Connected to
 Cap: 172159-1
 Socket: 170362-1 or 170366-1

- Motor Wiring Specifications

1	Phase U	Red
2	Phase V	White
3	Phase W	Blue
4	FG (Frame Ground)	Green/Yellow

Encoder Plug

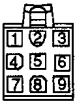

Plug: 172169-1 (Made by AMP)
 Pin: 170359-1 or 170363-1
 Connected to
 Cap: 172161-1
 Socket: 170361-1 or 170365-1

- Incremental Encoder Wiring Specifications

1	A channel output	Blue
2	\bar{A} channel output	Blue/Black
3	B channel output	Yellow
4	\bar{B} channel output	Yellow/Black
5	C channel output	Green
6	\bar{C} channel output	Green/Black
7	0 V (Power Supply)	Gray
8	+5 V (Power Supply)	Red
9	FG (Frame Ground)	Orange

6.4.1 Servomotor Dimensional Drawings

● 1.5kW

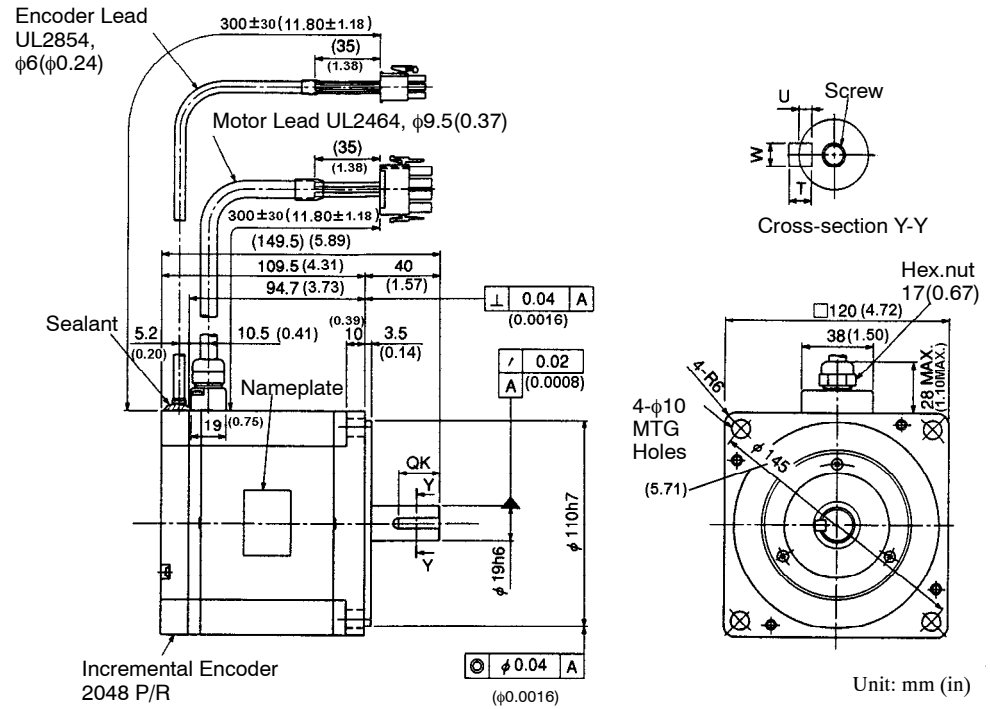

Model SGMP-	QK	U	W	T	Screw Dimensions	Output W (HP)	Approx. Mass kg (lb)	Allowable Radial Load N (lb)	Allowable Thrust Load N (lb)
15A312	No key				No screw	1500 (2.02)	6.6 (14.551)	490 (110)	147 (33.0)
15A314	22 (0.87)	3.5 (0.14)	6 (0.24)	6 (0.24)	No screw				
15A316	22 (0.87)	3.5 (0.14)	6 (0.24)	6 (0.24)	M6 Depth: 10 (0.39)				

Note: 1. An incremental encoder (2048 P/R) is used as a detector.

2. Model "A" indicated 200V specification.

3. Models 15A314 and 15A316 are fitted with a key. The keyway conforms to JIS B 1301-1976 (precision). A parallel key is supplied.

4. The quoted allowable radial load is the value at a position 35 mm (1.38 in.) from the motor mounting surface.

- Details of Motor and Encoder Plugs (1.5 kW)

Motor Plug

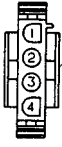

Plug : 350779-1 (Made by AMP)
 Pin: 350218-6 or 350547-6
 Connected to
 Cap: 350780-1
 Socket: 350536-6 or 350550-6

- Motor Wiring Specifications

1	Phase U	Red
2	Phase V	White
3	Phase W	Blue
4	FG (Frame Ground)	Green/Yellow

Encoder Plug



Plug: 172169-1 (Made by AMP)
 Pin: 170359-1 or 170363-1
 Connected to
 Cap :172161-1
 Socket: 170361-1 or 170365-1

- Incremental Encoder Wiring Specifications

1	A channel output	Blue
2	\bar{A} channel output	Blue/Black
3	B channel output	Yellow
4	\bar{B} channel output	Yellow/Black
5	C channel output	Green
6	\bar{C} channel output	Green/Black
7	0 V (Power Supply)	Gray
8	+5 V (Power Supply)	Red
9	FG (Frame Ground)	Orange

With Incremental Encoder (2048 P/R) and Brake

- 200 W, 400 W

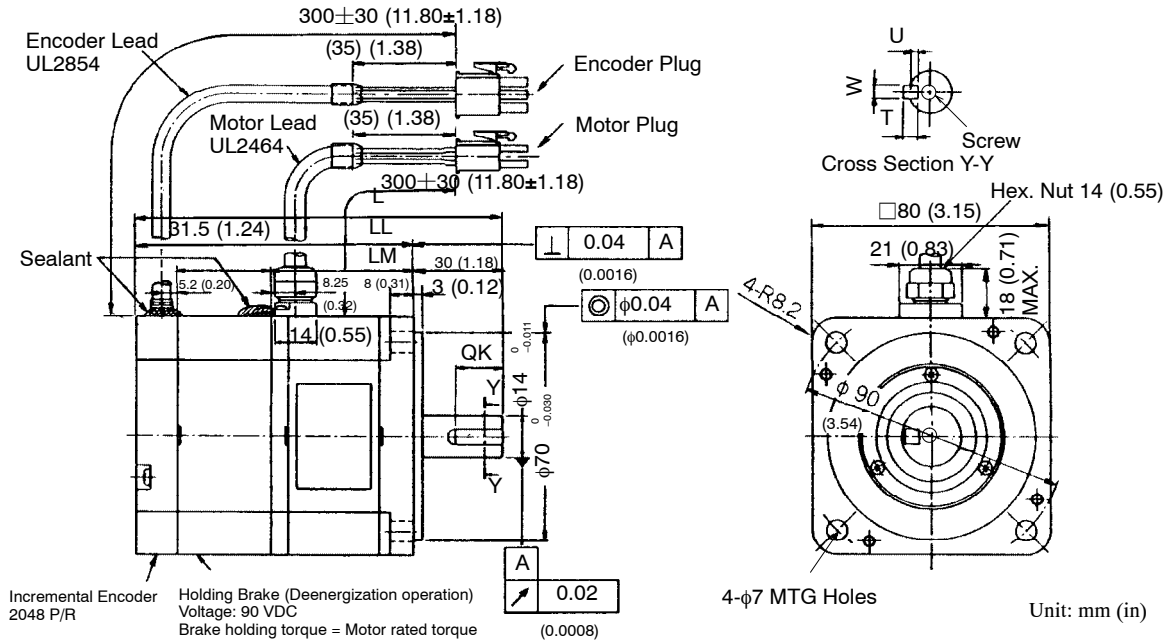

Model SGMP-	L	LL	LM	QK	U	W	T	Output W (HP)	Approx. Mass kg (lb)	Allowable Radial Load N (lb)	Allowable Thrust Load N (lb)
02A312B	123.5 (4.86)	93.5 (3.68)	48.1 (1.89)	No key				200 (0.272)	1.9 (4.189)	245 (55.1)	68 (15.3)
02A314B				16 (0.63)	3 (0.12)	5 (0.20)	5 (0.20)				
04A312B	143.5 (5.65)	113.5 (4.47)	68.1 (2.68)	No key				400 (0.54)	2.6 (5.732)	245 (55.1)	68 (15.3)
04A314B				16 (0.63)	3 (0.12)	5 (0.20)	5 (0.20)				

Note: 1. An incremental encoder (2048 P/R) is used as a detector.

2. Model 0□A314B is fitted with a key. The keyway conforms to JIS B 1301-1976 (precision). A parallel key is supplied.
3. The quoted allowable radial load is the value at a position 25 mm (0.98 in.) from the motor mounting surface.
4. Use the electromagnetic brake to hold the load in position only, and do not use it to stop the motor.
5. Protective structure: IP55 (excluding connector and side of output shaft).

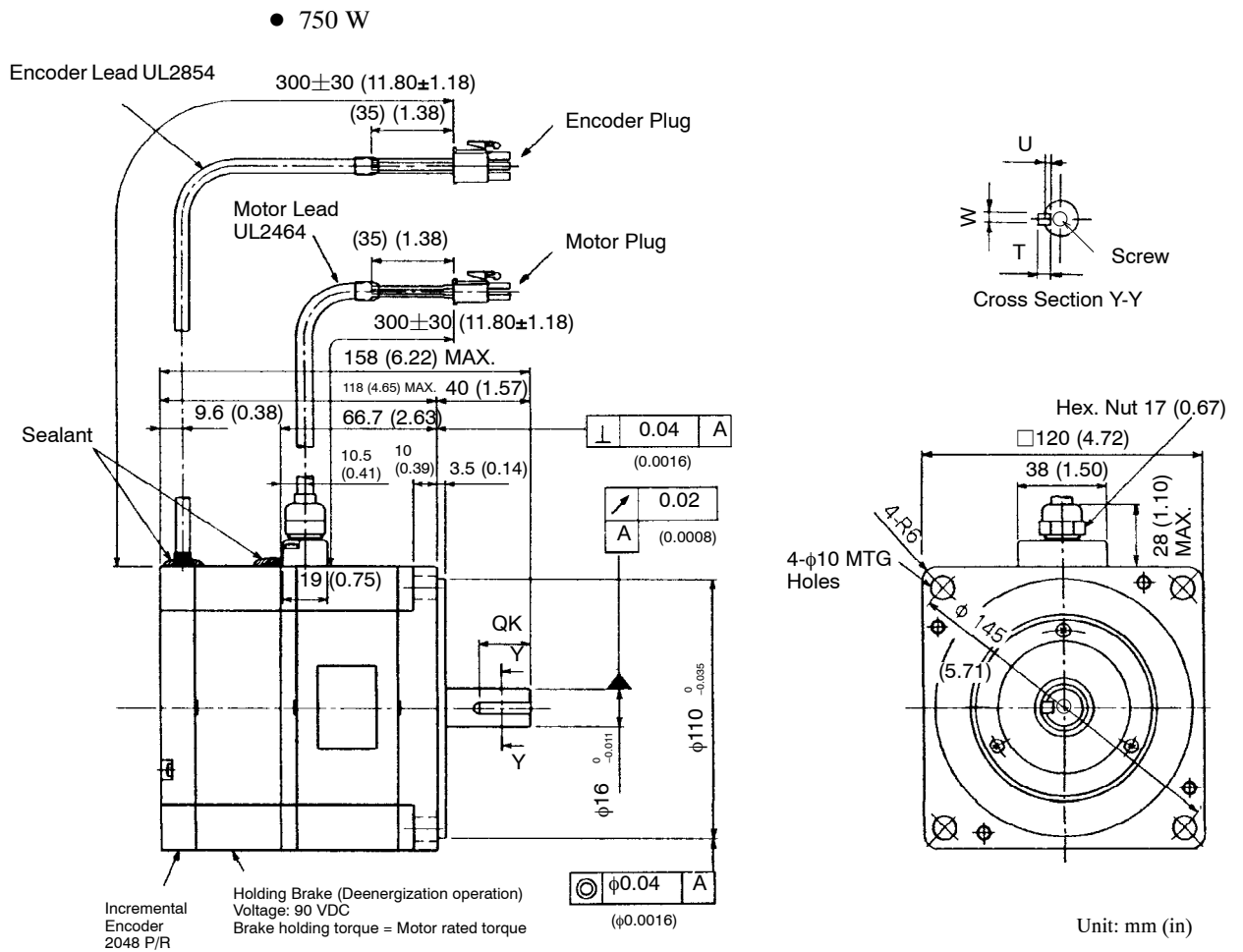

Model SGMP-	QK	U	W	T	Output W (H)	Approx. Mass kg (lb)	Allowable Radial Load N (lb)	Allowable Thrust Load N (lb)
08A312B	No key				750 (1.01)	6.1 (13.448)	392 (88.1)	147 (33.0)
08A314B	22 (0.87)	3 (0.12)	5 (0.20)	5 (0.20)				

- Note: 1. An incremental encoder (2048 P/R) is used as a detector.
 2. Model 08A314B is fitted with a key. The keyway conforms to JIS B 1301-1976 (precision). A parallel key is supplied.
 3. The quoted allowable radial load is the value at a position 35 mm (1.38 in.) from the motor mounting surface.
 4. Use the electromagnetic brake to hold the load in position only, and do not use it to stop the motor.
 5. Protective structure: IP55 (excluding connector and side of output shaft).

• Details of Motor and Encoder Plugs (200 W, 400 W, 750 W)

Motor Plug



Plug: 172168-1 (Made by AMP)
 Pin: 170360-1 or 170364-1
 Connected to
 Cap: 172160-1
 Socket: 170362-1 or 170366-1

• Motor Wiring Specifications

1	Phase U	Red
2	Phase V	White
3	Phase W	Blue
4	FG (Frame Ground)	Green/Yellow
5	Brake terminal	Black
6	Brake terminal	Black

Encoder Plug



Plug: 172169-1 (Made by AMP)
 Pin: 170359-1 or 170363-1
 Connected to
 Cap: 172161-1
 Socket: 170361-1 or 170365-1

• Incremental Encoder Wiring Specifications

1	A channel output	Blue
2	\bar{A} channel output	Blue/Black
3	B channel output	Yellow
4	\bar{B} channel output	Yellow/Black
5	C channel output	Green
6	\bar{C} channel output	Green/Black
7	0 V (Power Supply)	Gray
8	+5 V (Power Supply)	Red
9	FG (Frame Ground)	Orange

● 1.5kW

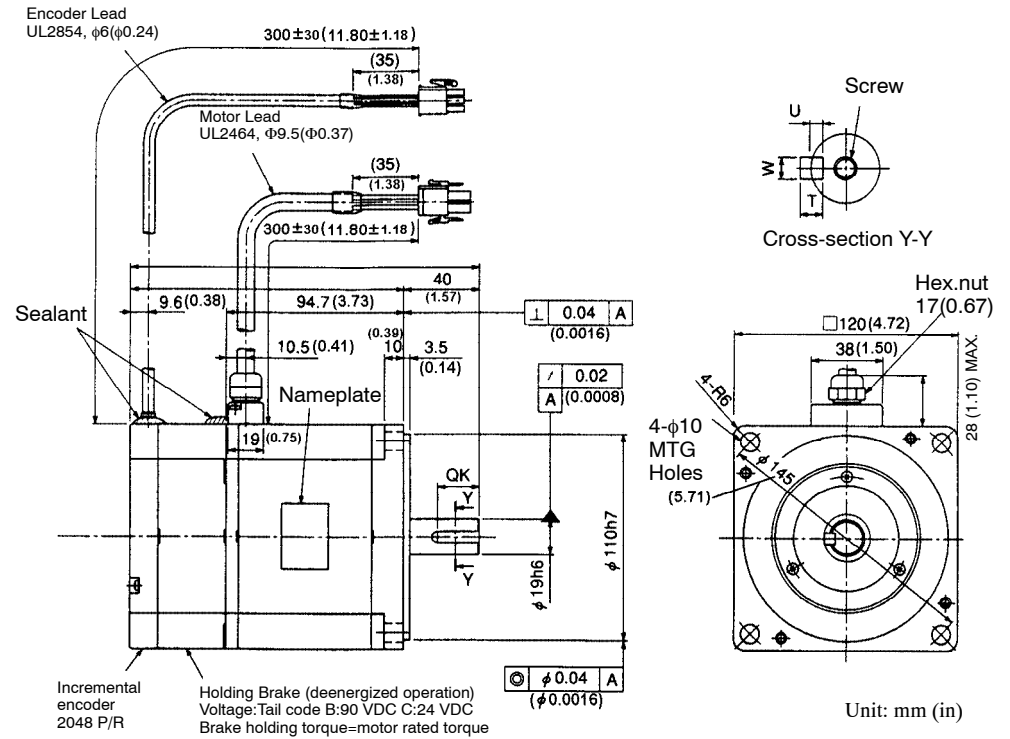

Model SGMP-	QK	U	W	T	Screw Dimensions	Output W (HP)	Approx. Mass kg (lb)	Allowable Radial Load N (lb)	Allowable Thrust Load N (lb)
15A312B	No key				No screw	1500 (2.02)	8.1 (17.858)	490 (110)	147 (33.0)
15A312C									
15A314B	22 (0.87)	3.5 (0.14)	6 (0.24)	6 (0.24)	No screw	1500 (2.02)	8.1 (17.858)	490 (110)	147 (33.0)
15A314C									
15A316B					M6, Depth: 10 (0.39)				
15A316C									

Note: 1. An incremental encoder (2048 P/R) is used as a detector.

2. Model "A" indicates 200 V specification.

3. "15A314B(C)" and "15A316B(C)" are fitted with a key. The keyway conforms to JIS B 1301-1976 (precision). A parallel key is supplied.

4. The quoted allowable radial load is the value at a position 35 mm (1.40 in.) from the motor mounting surface.

5. Use the electromagnetic brake to hold the load in position only, and do not use it to stop the motor.

● Details of Motor and Encoder Plugs (1.5 kW)

Motor Plug



Plug : 350715-1 (Made by AMP)
 Pin: 350218-6 or 350547-6 (pins 1 to 4)
 350561-1 or 350690-1 (pins 5 and 6)
 Connected to
 Cap: 350781-1
 Socket: 350536-6 or 350550-6

● Motor Wiring Specifications

1	Phase U	Red
2	Phase V	White
3	Phase W	Blue
4	FG (Frame Ground)	Green/Yellow
5	Brake terminal	Black
6	Brake terminal	Black

Encoder Plug



Plug: 172169-1 (Made by AMP)
 Pin: 170359-1 or 170363-1
 Connected to
 Cap :172161-1
 Socket: 170361-1 or 170365-1

● Incremental Encoder Wiring Specifications

1	A channel output	Blue
2	\bar{A} channel output	Blue/Black
3	B channel output	Yellow
4	\bar{B} channel output	Yellow/Black
5	C channel output	Green
6	\bar{C} channel output	Green/Black
7	0 V (Power Supply)	Gray
8	+5 V (Power Supply)	Red
9	FG (Frame Ground)	Orange

With Absolute Encoder (12-bit : 1024 P/R)

- 200 W, 400 W

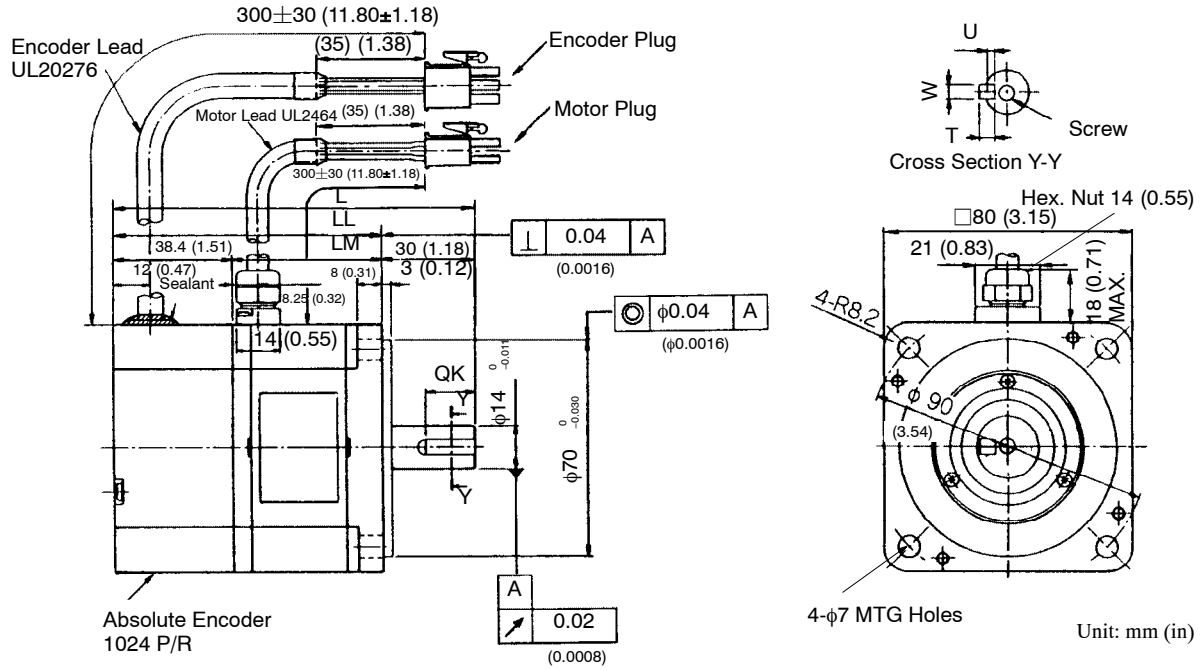

Model SGMP-	L	LL	LM	QK	U	W	T	Screw Dimensions	Output W (HP)	Approx. Mass kg (lb)	Allowable Radial Load N (lb)	Allowable Thrust Load N (lb)
02AW12	116.5 (4.59)	86.5 (3.41)	48.1 (1.89)	No key				-	200 (0.272)	1.6 (3.527)	245 (55.1)	68 (15.3)
02AW14				16 (0.63)	3 (0.12)	5 (0.20)	5 (0.20)					
02AW16				M5 Depth: 8 (0.31)								
04AW12	136.5 (5.37)	106.5 (4.19)	68.1 (2.68)	No key				-	400 (0.54)	2.3 (5.071)	245 (55.1)	68 (15.3)
04AW14				16 (0.63)	3 (0.12)	5 (0.20)	5 (0.20)					
04AW16				M5 Depth: 8 (0.31)								

- Note: 1. An absolute encoder (12-bit: 1024 P/R) is used as a detector.
2. Models 0□AW14 and 0□AW16 are fitted with a key. The keyway conforms to JIS B 1301-1976 (precision). A parallel key is supplied.
3. The quoted allowable radial load is the value at a position 25 mm (0.98 in.) from the motor mounting surface.
4. Protective structure: IP55 (excluding connector and side of output shaft).

6.4.1 Servomotor Dimensional Drawings

- 750 W

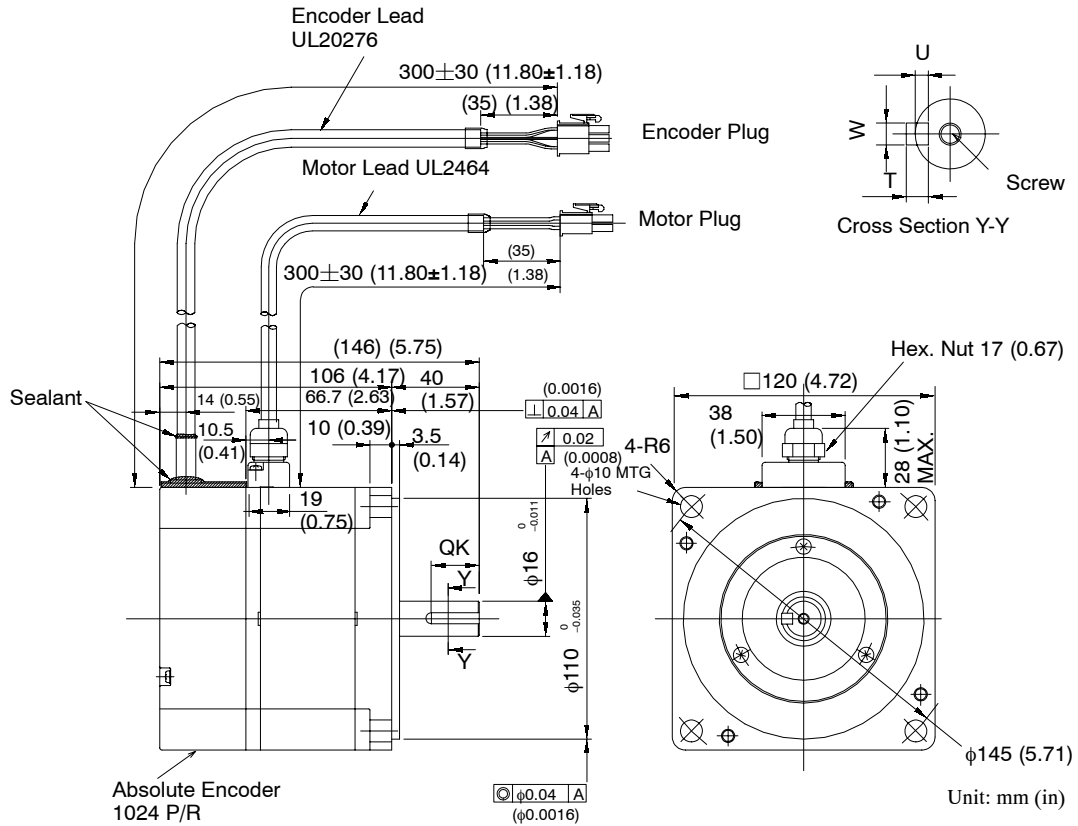

Model SGMP-	QK	U	W	T	Output W (H)	Approx. Mass kg (lb)	Allowable Radial Load N (lb)	Allowable Thrust Load N (lb)
08AW12	No key				750 (1.01)	4.8 (10.582)	392 (88.1)	147 (33.0)
08AW14	22 (0.87)	3 (0.12)	5 (0.20)	5 (0.20)				

Note: 1. An absolute encoder (12-bit: 1024 P/R) is used as a detector.

2. Model 08AW14 is fitted with a key. The keyway conforms to JIS B 1301-1976 (precision). A parallel key is supplied.

3. The quoted allowable radial load is the value at a position 35 mm (1.38 in.) from the motor mounting surface.

4. Protective structure: IP55 (excluding connector and side of output shaft).

- Details of Motor and Encoder Plugs (200 W, 400 W, 750 W)

Motor Plug



Plug: 172167-1 (Made by AMP)
 Pin: 170360-1 or 170364-1
 Connected to
 Cap: 172159-1
 Socket: 170362-1 or 170366-1

- Motor Wiring Specifications

1	Phase U	Red
2	Phase V	White
3	Phase W	Blue
4	FG (Frame Ground)	Green/Yellow

Encoder Plug

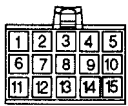

Plug: 172171-1 (Made by AMP)
 Pin: 170359-1 or 170363-1
 Connected to
 Cap: 172163-1
 Socket: 170361-1 or 170365-1

- Absolute Encoder Wiring Specifications

1	A channel output	Blue
2	\bar{A} channel output	White/Blue
3	B channel output	Yellow
4	\bar{B} channel output	White/Yellow
5	Z channel output	Green
6	\bar{Z} channel output	White/Green
7	0 V (Power Supply)	Black
8	+5 V (Power Supply)	Red
9	FG (Frame Ground)	Green/Yellow
10	S channel output	Purple
11	\bar{S} channel output	White/Purple
(12)*	(Capacitor Reset)	(Gray)
13	Reset	White/Gray
14	0 V(battery)	White/Orange
15	3.6 V(battery)	Orange

* Terminal to discharge capacitor for product dispatch. Do not use.

6.4.1 Servomotor Dimensional Drawings

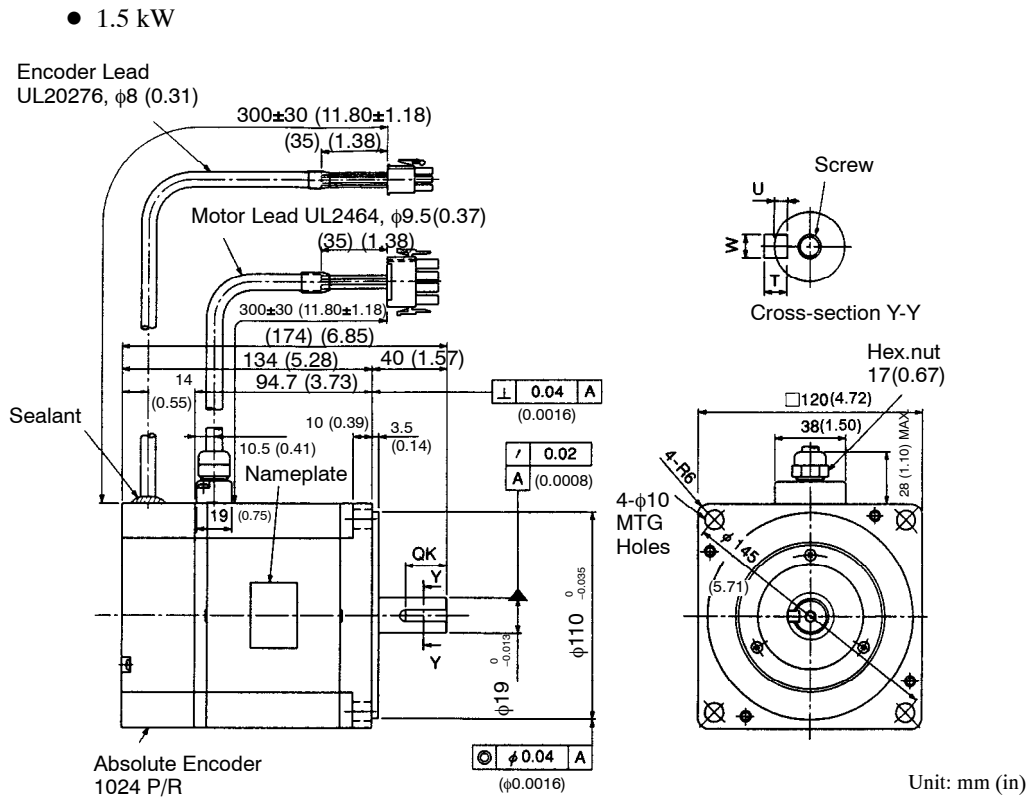

Model SGMP-	QK	U	W	T	Screw Dimensions	Output W (HP)	Approx. Mass kg kg (lb)	Allowable Radial Load N (lb)	Allowable Thrust Load N (lb)
15AW12	No key				No screw	1500 (2.01)	7.1 (15.653)	490 (110)	147 (33.0)
15AW14	22 (0.87)	3.5 (0.14)	6 (0.24)	6 (0.24)	M6 Depth: 10 (0.39)				
15AW16									

- Note: 1. An absolute encoder (12-bit: 1024 P/R) is used as a detector.
2. Model "A" indicated 200V specification.
3. Models 15AW14 and 15AW16 are fitted with a key. The keyway conforms to JIS B 1301-1976 (precision). A parallel key is supplied.
4. The quoted allowable radial load is the value at a position 35 mm (1.38 in.) from the motor mounting surface.

- Details of Motor and Encoder Plugs (1.5 kW)

Motor Plug

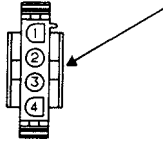

Plug: 350779-1 (Made by AMP)
 Pin: 350218-6 or 350547-6
 Connected to
 Cap: 350780-1
 Socket: 350536-6 or 350550-6

- Motor Wiring Specifications

1	Phase U	Red
2	Phase V	White
3	Phase W	Blue
4	FG (Frame Ground)	Green/Yellow

Encoder Plug

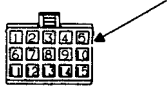

Plug: 172171-1 (Made by AMP)
 Pin: 170359-1 or 170363-1
 Connected to
 Cap: 172163-1
 Socket: 170361-1 or 170365-1

- Absolute Encoder Wiring Specifications

1	A channel output	Blue
2	\bar{A} channel output	White/Blue
3	B channel output	Yellow
4	\bar{B} channel output	White/Yellow
5	Z channel output	Green
6	\bar{Z} channel output	White/Green
7	0 V (Power Supply)	Black
8	+5 V (Power Supply)	Red
9	FG (Frame Ground)	Green/Yellow
10	S channel output	Purple
11	\bar{S} channel output	White/Purple
(12)*	(Capacitor Reset)	(Gray)
13	Reset	White/Gray
14	0 V(battery)	White/Orange
15	3.6 V(battery)	Orange

* Terminal to discharge capacitor for product dispatch. Do not use.

With Absolute Encoder (12-bit : 1024 P/R) and Brake

- 200 W, 400 W

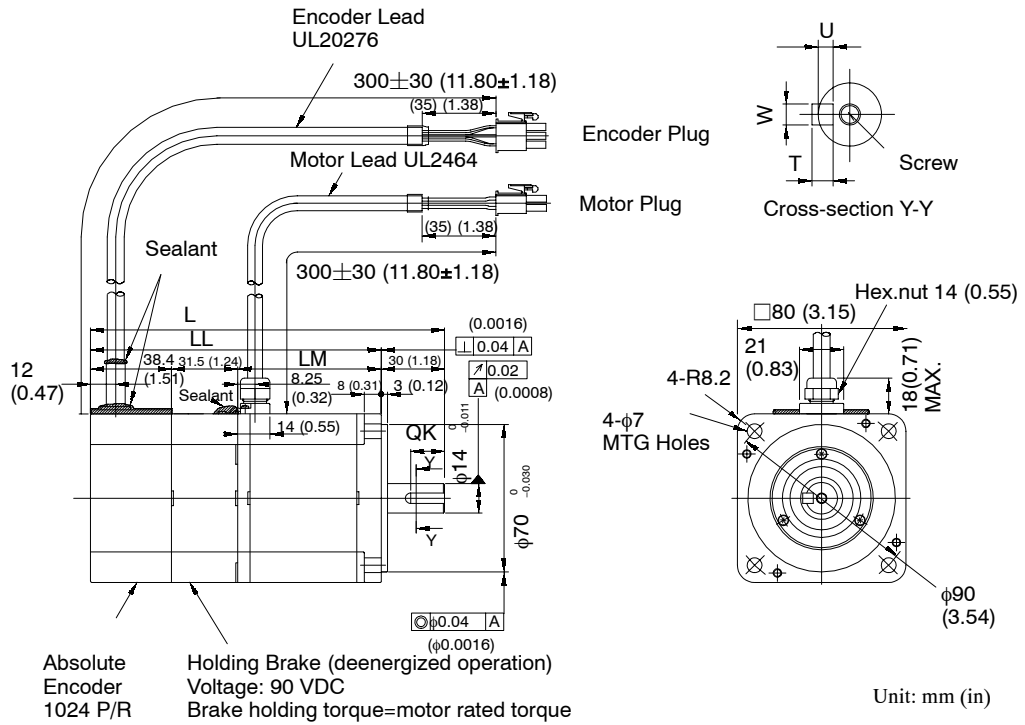

Model SGMP-	L	LL	LM	QK	U	W	T	Screw Dimensions	Output W (HP)	Approx. Mass kg (lb)	Allowable Radial Load N (lb)	Allowable Thrust Load N (lb)
02AW12 B	148 (5.83)	118 (4.65)	48.1 (1.89)	No key				-	200 (0.272)	2.1 (4.630)	245 (55.1)	68 (15.3)
02AW14 B				16 (0.63)	3 (0.12)	5 (0.20)	5 (0.20)	M5 Depth: 8 (0.31)				
02AW16 B												
04AW12 B	168 (6.61)	138 (5.43)	68.1 (2.68)	No key				-	400 (0.54)	3.0 (6.614)	245 (55.1)	68 (15.3)
04AW14 B				16 (0.63)	3 (0.12)	5 (0.20)	5 (0.20)	M5 Depth: 8 (0.31)				
04AW16 B												

Note: 1. An absolute encoder (12-bit: 1024 P/R) is used as a detector.

- Models 0□AW14B and 0□AW16B are fitted with a key. The keyway conforms to JIS B 1301-1976 (precision). A parallel key is supplied.
- The quoted allowable radial load is the value at a position 25 mm (0.98 in.) from the motor mounting surface.
- Use the electromagnetic brake to hold the load in position only, and do not use it to stop the motor.
- Protective structure: IP55 (excluding connector and side of output shaft).

● 750 W

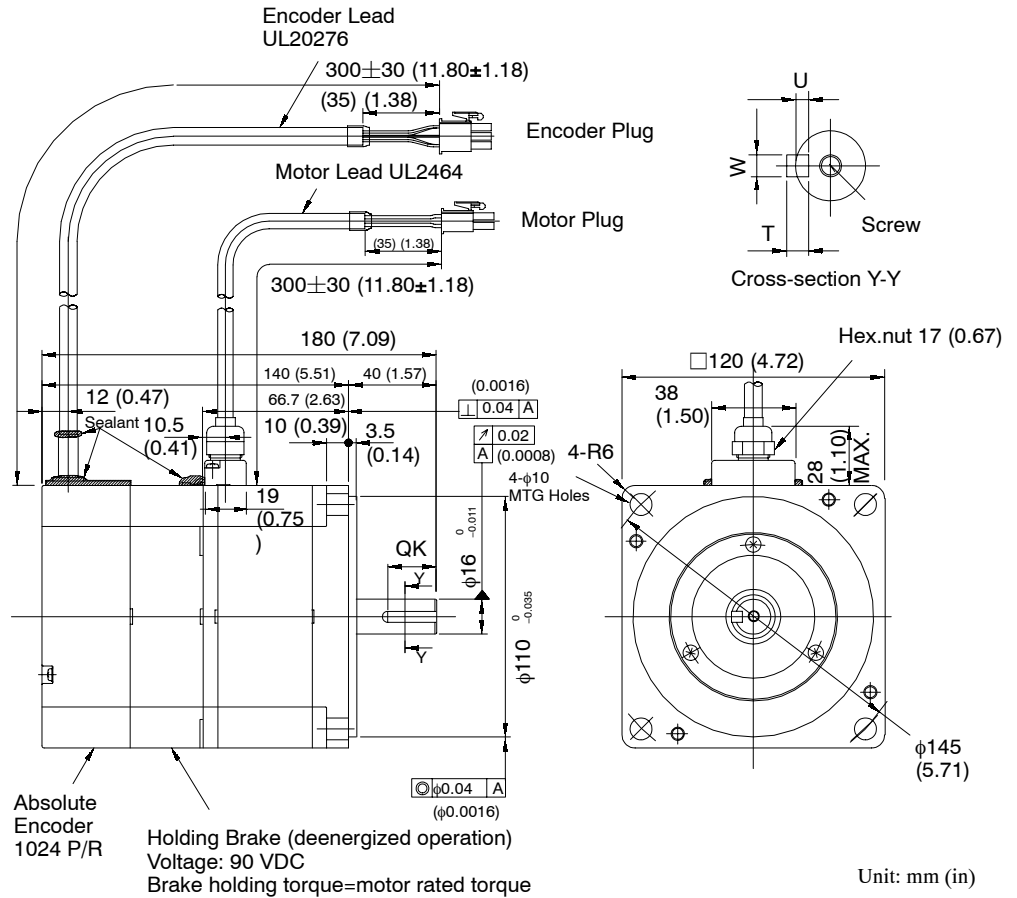

Model SGMP-	QK	U	W	T	Output W (HP)	Approx. Mass kg (lb)	Allowable Radial Load N (lb)	Allowable Thrust Load N (lb)
08AW12B	No key				750 (1.01)	6.2 (13.669)	392 (88.1)	147 (33.0)
08AW14B	22 (0.87)	3 (0.12)	5 (0.20)	5 (0.20)				

- Note: 1. An absolute encoder (12-bit: 1024 P/R) is used as a detector.
2. Model 08AW14B is fitted with a key. The keyway conforms to JIS B 1301-1976 (precision). A parallel key is supplied.
3. The quoted allowable radial load is the value at a position 35 mm (1.38 in.) from the motor mounting surface.
4. Use the electromagnetic brake to hold the load in position only, and do not use it to stop the motor.
5. Protective structure: IP55 (excluding connector and side of output shaft).

● Details of Motor and Encoder Plugs (200 W, 400 W, 750 W)

Motor Plug



Plug: 172168-1 (Made by AMP)
 Pin: 170360-1 or 170364-1 (pins 1 to 4)
 170359-1 or 170363-1 (pins 5 and 6)
 (170360-1 or 170363-1: 750 W only)
 Connected to
 Cap: 172160-1
 Socket: 170362-1 or 170366-1

● Motor Wiring Specifications

1	Phase U	Red
2	Phase V	White
3	Phase W	Blue
4	FG (Frame Ground)	Green/Yellow
5	Brake terminal	Black
6	Brake terminal	Black

Encoder Plug

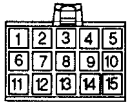

Plug: 172171-1 (Made by AMP)
 Pin: 170359-1 or 170363-1
 Connected to
 Cap: 172163-1
 Socket: 170361-1 or 170365-1

● Absolute Encoder Wiring Specifications

1	A channel output	Blue
2	\bar{A} channel output	White/Blue
3	B channel output	Yellow
4	\bar{B} channel output	White/Yellow
5	Z channel output	Green
6	\bar{Z} channel output	White/Green
7	0 V (Power Supply)	Black
8	+5 V (Power Supply)	Red
9	FG (Frame Ground)	Green/Yellow
10	S channel output	Purple
11	\bar{S} channel output	White/Purple
(12)*	(Capacitor Reset)	(Gray)
13	Reset	White/Gray
14	0 V (battery)	White/Orange
15	3.6 V (battery)	Orange

* Terminal to discharge capacitor for product dispatch. Do not use.

● 1.5kW

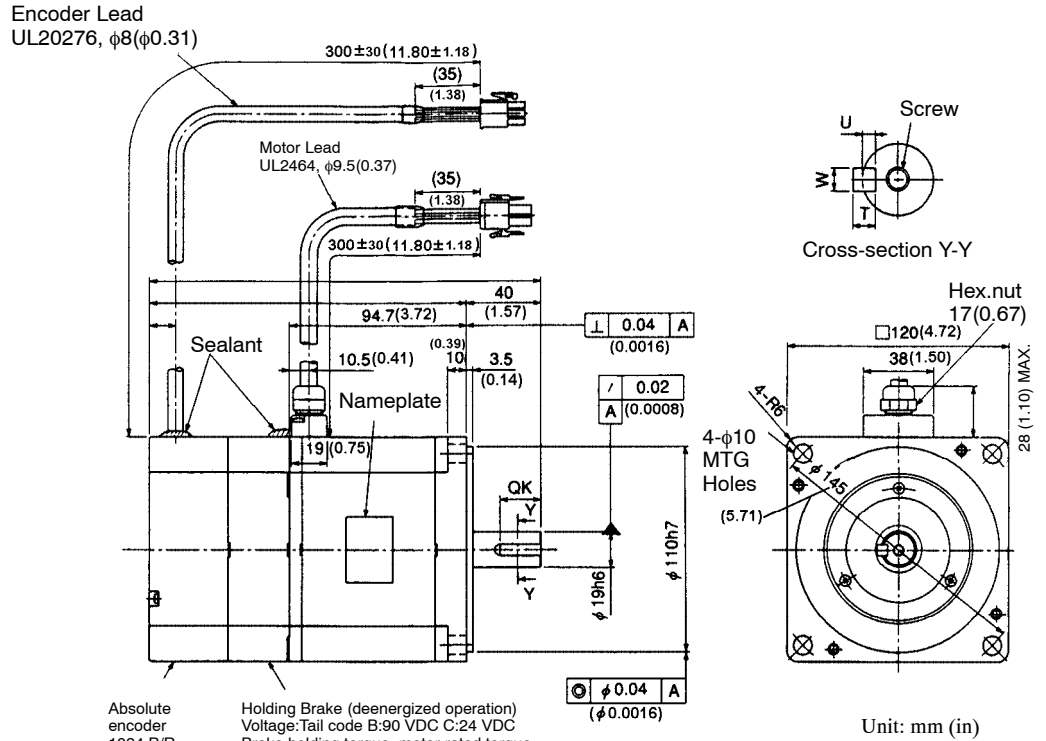

Model SGMP-	QK	U	W	T	Screw Dimensions	Output W (HP)	Approx. Mass kg (lb)	Allowable Radial Load N (lb)	Allowable Thrust Load N (lb)
15AW12B	No key				No Screw	1500 (2.02)	8.6 (18.960)	490 (110)	147 (33.0)
15AW12C									
15AW14B	22 (0.87)	3.5 (0.14)	6 (0.24)	6 (0.24)	No Screw				
15AW14C									
15AW16B					M6				
15AW16C					Depth: 10 (0.39)				

- Note: 1. An absolute encoder (12-bit: 1024 P/R) is used as a detector.
2. Model "A" indicates 200 V specification.
3. "15AW14B(C)" and "15AW16B(C)" are fitted with a key. The keyway conforms to JIS B 1301-1976 (precision). A parallel key is supplied.
4. The quoted allowable radial load is the value at a position 35 mm (1.40 in.) from the motor mounting surface.
5. Use the electromagnetic brake to hold the load in position only, and do not use it to stop the motor.

● Details of Motor and Encoder Plugs (1.5 kW)

Motor Plug

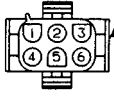

Plug : 350715-1 (Made by AMP)
 Pin: 350218-6 or 350547-6 (pins 1 to 4)
 350561-1 or 350690-1 (pins 5 and 6)
 Connected to
 Cap: 350781-1
 Socket: 350536-6 or 350550-6

Encoder Plug



Plug: 172171-1 (Made by AMP)
 Pin: 170359-1 or 170363-1
 Connected to
 Cap :172163-1
 Socket: 170361-1 or 170365-1

● Motor Wiring Specifications

1	Phase U	Red
2	Phase V	White
3	Phase W	Blue
4	FG (Frame Ground)	Green/Yellow
5	Brake terminal	Black
6	Brake terminal	Black

● Absolute Encoder Wiring Specifications

1	A channel output	Blue
2	\bar{A} channel output	White/Blue
3	B channel output	Yellow
4	\bar{B} channel output	White/Yellow
5	Z channel output	Green
6	\bar{Z} channel output	White/Green
7	0 V (Power Supply)	Black
8	+5 V (Power Supply)	Red
9	FG (Frame Ground)	Green/Yellow
10	S channel output	Purple
11	\bar{S} channel output	White/Purple
(12)*	(Capacitor Reset)	(Gray)
13	Reset	White/Gray
14	0 V(battery)	White/Orange
15	3.6 V(battery)	Orange

* Terminal to discharge capacitor for product dispatch. Do not use.

■ Connectors on Detector and Motor Ends

The connectors on the detector and motor ends are divided into two types: standard connector and IP67-based connector. The standard connector is not drip-proof.

Standard Connector

The standard connectors for Servomotors with and without holding brake are different.

Table 6.12 Standard Connectors for SGM□ Servomotors without Holding Brake

Motor Model	Connectors on Motor End			
	Receptacle	L-shaped Plug	Straight Plug	Cable Clamp
SGMS- 10A□A 15A□A 20A□A	MS3102A18-10P	MS3108B18-10S	MS3106B18-10S	MS3057-10A
30A□A 40A□A 50A□A	MS3102A22-22P	MS3108B22-22S	MS3106B22-22S	MS3057-12A
SGMG- 05A□A 09A□A 13A□A	MS3102A18-10P	MS3108B18-10S	MS3106B18-10S	MS3057-10A
20A□A 30A□A 44A□A	MS3102A22-22P	MS3108B22-22S	MS3106B22-22S	MS3057-12A
55A□A 75A□A 1AA□A 1EA□A	MS3102A32-17P	MS3108B32-17S	MS3106B32-17S	MS3057-20A

Connector on motor side already provided

To be prepared by customer (cable)

6.4.1 Servomotor Dimensional Drawings

Motor Model	Connectors on Motor End			
	Receptacle	L-shaped Plug	Straight Plug	Cable Clamp
SGMG- 03A□B 06A□B 09A□B	MS3102A18-10P	MS3108B18-10S	MS3106B18-10S	MS3057-10A
12A□B 20A□B 30A□B	MS3102A22-22P	MS3108B22-22S	MS3106B22-22S	MS3057-12A
44A□B 60A□B	MS3102A32-17P	MS3108B32-17S	MS3106B32-17S	MS3057-20A
SGMD- 22A□A 32A□A 40A□A	MS3102A24-10P	MS3108B24-10S	MS3106B24-10S	MS3057-16A

Connector on motor side already provided
To be prepared by customer (cable)

6

Motor Model	Connectors on Detector End			
	Receptacle	L-shaped Plug	Straight Plug	Cable Clamp
SGMS- 10A□A 15A□A 20A□A 30A□A 40A□A 50A□A	MS3102A20-29P	MS3108B20-29S	MS3106B20-29S	MS3057-12A

Motor Model	Connectors on Detector End			
	Receptacle	L-shaped Plug	Straight Plug	Cable Clamp
SGMG- 05A□A 09A□A 13A□A 20A□A 30A□A 44A□A 55A□A 75A□A 1AA□A 1EA□A	MS3102A20-29P	MS3108B20-29S	MS3106B20-29S	MS3057-12A
SGMG- 03A□B 06A□B 09A□B 12A□B 20A□B 30A□B 44A□B 60A□B	MS3102A20-29P	MS3108B20-29S	MS3106B20-29S	MS3057-12A
SGMD- 22A□A 32A□A 40A□A	MS3102A20-29P	MS3108B20-29S	MS3106B20-29S	MS3057-12A

Connector on motor
side already provided

To be prepared by customer (cable)

Table 6.13 Connectors for SGM□ Servomotors with Holding Brake

Motor Model		Connectors on Motor End			
		Receptacle	L-shaped Plug	Straight Plug	Cable Clamp
SGMS-	10A□A 15A□A 20A□A	MS3102A20-15P	MS3108B20-15S	MS3106B20-15S	MS3057-12A
	30A□A 40A□A 50A□A	MS3102A24-10P	MS3108B24-10S	MS3106B24-10S	MS3057-16A
SGMG-	05A□A 09A□A 13A□A	MS3102A20-15P	MS3108B20-15S	MS3106B20-15S	MS3057-12A
	20A□A 30A□A 44A□A	MS3102A24-10P	MS3108B24-10S	MS3106B24-10S	MS3057-16A
	55A□A 75A□A 1AA□A	MS3102A32-17P MS3102A10SL-3P	MS3108B32-17S MS3108B10SL-3S	MS3106B32-17S MS3106A10SL-3S	MS3057-20A MS3057-4A
	SGMG-	03A□B 06A□B 09A□B	MS3102A20-15P	MS3108B20-15S	MS3106B20-15S
12A□B 20A□B 30A□B		MS3102A24-10P	MS3108B24-10S	MS3106B24-10S	MS3057-16A
	44A□B 60A□B	MS3102A32-17P MS3102A10SL-3P	MS3108B32-17S MS3108B10SL-3S	MS3106B32-17S MS3106A10SL-3S	MS3057-20A MS3057-4A

Note: In cells containing two rows, the upper row connector model is for the motor circuit and the connector model lower row is for the brake power supply.

Motor Model	Connectors on Motor End			
	Receptacle	L-shaped Plug	Straight Plug	Cable Clamp
SGMD- 22A□A 32A□A 40A□A	MS3102A24-10P	MS3108B24-10S	MS3106B24-10S	MS3057-16A

Connector on motor
side already provided

To be prepared by customer (cable)

Motor Model	Connectors on Detector End			
	Receptacle	L-shaped Plug	Straight Plug	Cable Clamp
SGMS- 10A□A 15A□A 20A□A 30A□A 40A□A 50A□A	MS3102A20-29P	MS3108B20-29S	MS3106B20-29S	MS3057-12A
SGMG- 05A□A 09A□A 13A□A 20A□A 30A□A 44A□A 55A□A 75A□A 1AA□A 1EA□A	MS3102A20-29P	MS3108B20-29S	MS3106B20-29S	MS3057-12A

6.4.1 Servomotor Dimensional Drawings

Motor Model	Connectors on Detector End			
	Receptacle	L-shaped Plug	Straight Plug	Cable Clamp
SGMG- 03A□B 06A□B 09A□B 12A□B 20A□B 30A□B 44A□B 60A□B	MS3102A20-29P	MS3108B20-29S	MS3106B20-29S	MS3057-12A
SGMD- 22A□A 32A□A 40A□A	MS3102A20-29P	MS3108B20-29S	MS3106B20-29S	MS3057-12A

Connector on detector side already provided

To be prepared by customer (cable)

IP67-based Connectors

IP67-base connectors for servomotors without a holding brake differ from those for servomotors with a holding brake.

Table 6.14 Connectors for SGM□ Servomotors without Holding Brake

	Motor Model	Receptacle	Plug	End Bell: Manufactured by Japan Aviation Electronics Industry, Ltd. Back Shell: Manufactured by Daiichi Denshi Kogyo K.K.		Cable Clamp	Manufacturer
				Angle (L-Shaped)	Straight		
M o t o r	SGMS- 10A□A 15A□A 20A□A	CE05-2A18-10PD (MS3102A18-10P)	MS3106A18-10S(D190)	CE-18BA-S	CE02-18BS-S	CE3057-10A-*	Daiichi Denshi Kogyo K.K.
	SGMG- 05A□A 09A□A 13A□A	CE05-2A18-10PD (MS3102A18-10P)	MS3106A18-10S(D190)	CE-18BA-S	CE02-18BS-S	CE3057-10A-*	Daiichi Denshi Kogyo K.K.
	55A□A 75A□A 1AA□A 1EA□A	JL04HV-2E32-17PE-B (MS3102A32-17P)	JL04V-6A32-17SE	*1	*1	*1	Japan Aviation Electronics Industry, Ltd.

Connector on motor side already provided

To be selected if flexible conduit is used

Not required if flexible conduit is used

To be prepared by customer (cable)

6.4.1 Servomotor Dimensional Drawings

	Motor Model	Receptacle	Plug	End Bell: Manufactured by Japan Aviation Electronics Industry, Ltd. Back Shell: Manufactured by Daiichi Denshi Kogyo K.K.		Cable Clamp	Manufacturer
				Angle (L-Shaped)	Straight		
M o t o r	SGMG- 03A□B 06A□B 09A□B	CE05-2A18-10PD (MS3102A18-10P)	MS3106A18-10S(D190)	CE-18BA-S	CE02-18BS-S	CE3057-10A-*	Daiichi Denshi Kogyo K.K.
	12A□B 20A□B 30A□B	JL04HV-2E22-22PE-B (MS3102A22-22P)	JL04V-6A22-22SE	JL04-22EBL	JL04-22EB	JL04-2022CK (14)	Japan Aviation Electronics Industry, Ltd.
	44A□B 60A□B	JL04V-2E32-17PE-B (MS3102A24-10P)	JL04V-6A32-17SE	*1	*1	*1	Japan Aviation Electronics Industry, Ltd.
	SGMD- 22A□A 32A□A 40A□A	JL04V-2E24-10PE-B (MS3102A32-17P)	JL04-6A24-10SE	JL04-24EBL	JL04-24EB	JL04-2428CK (17)	Japan Aviation Electronics Industry, Ltd.
	Detector	97F3102E20-29P (MS3102A20-29P)	MS3106A20-29S(D190)	CE-20BA-S	CE02-20BS-S	CE3057-12A-*	Daiichi Denshi Kogyo K.K.

Connector on motor side already provided

To be selected if flexible conduit is used

Not required if flexible conduit is used

To be prepared by customer (cable)

* 1. The SGMG-55A□A, -75A□A, -1AA□A, -1EA□A, -44A□B, and -60A□B motors do not contain an End Bell. For these motors, use the following flexible conduit instead.

Connector		Conduit Model	Manufacturer
Angle (L-Shaped)	Straight		
RCC-3**RL-MS32F	RCC-1**RL-MS32F	VF-** (SR-**)	NIPPON FLEX CO., LTD.

6

Select an appropriate connector and conduit model (mark **) according to the lead wire diameter. For details, refer to page 6 -175.

- Note: 1. The connectors for a detector are the same regardless of the motor model being used.
 2. To ensure compliance with IP67, always use the plug, End Bell, Back Shell and cable clamp specified above.
 3. Select an appropriate cable clamp model (mark**) according to the lead wire diameter. For details, refer to page 6 -175.
 4. () in the receptacle column shows the standard (non-dripproof) model. However, both are actually the same receptacles.

Table 6.15 IP67-based Connectors for SGM□ Servomotors with Holding Brake

	Motor Model	Receptacle	Plug	End Bell: Manufactured by Japan Aviation Electronics Industry, Ltd. Back Shell: Manufactured by Daiichi Denshi Kogyo K.K.		Cable Clamp	Manufacturer
				Angle (L-Shaped)	Straight		
M o t o r	SGMS- 10A□A	JL04V-2E20- 15PE-B (MS3102A20-15P)	JL04V-6A20- 15SE	JL04-20EBL	JL04-20EB	JL04-2022C K (14)	Japan Aviation Electronics In- dustry, Ltd.
	15A□A						
	20A□A						
	30A□A	JL04-2E24- 10PE-B (MS3102A24-10P)	JL04V-6A24- 10SE	JL04-24EBL	JL04-24EB	JL04-2428C K (17)	Japan Aviation Electronics In- dustry, Ltd.
	40A□A						
50A□A							

Connector on motor
side already provided

To be selected
if flexible con-
duit is used

Not required if flexible conduit is used

To be prepared by customer (cable)

6.4.1 Servomotor Dimensional Drawings

	Motor Model	Receptacle	Plug	End Bell: Manufactured by Japan Aviation Electronics Industry, Ltd. Back Shell: Manufactured by Daiichi Denshi Kogyo K.K.		Cable Clamp	Manufacturer
				Angle (L-Shaped)	Straight		
Motor	SGMG- 05A□A 09A□A 13A□A	JL04V-2E20-15PE-B (MS3102A20-15P)	JL04V-6A20-15SE	JL04-20EBL	JL04-20EB	JL04-2022C K (14)	Japan Aviation Electronics In- dustry, Ltd.
	20A□A 30A□A 44A□A	JL04-2E24-10PE-B (MS3102A24-10P)	JL04V-6A24-10SE	JL04-24EBL	JL04-24EB	JL04-2428C K (17)	Japan Aviation Electronics In- dustry, Ltd.
	55A□A 75A□A 1AA□A 1EA□A	JL04V-2E32-17PE-B (MS3102A32-17P) CE05-2A10SL-3PC (MS3102A10SL-3P)	JL04V-6A32-17SE MS3106A10 SL-3S (D190)	*1 CE-10SLBA -S	*1 CE05-10SL BS-S	*1 CE3057-4A- 1	Japan Aviation Electronics In- dustry, Ltd. Daiichi Denshi Kogyo K.K.
	SGMG- 03A□B 06A□B 09A□B	JL04V-2E20-15PE-B (MS3102A20-15P)	JL04V-6A20-15SE	JL04-20EBL	JL04-20EB	JL04-2022C K (14)	Japan Aviation Electronics In- dustry, Ltd.
	12A□B 20A□B 30A□B	JL04-2E24-10PE-B (MS3102A24-10P)	JL04V-6A24-10SE	JL04-24EBL	JL04-24EB	JL04-2428C K (17)	Japan Aviation Electronics In- dustry, Ltd.
	44A□B 60A□B	JL04V-2E32-17PE-B (MS3102A32-17P) CE05-2A10SL-3PC (MS3102A10SL-3P)	JL04V-6A32-17SE MS3106A10 SL-3S(D190)	*1 CE-10SLBA -S	*1 CE05-10SL BS-S	*1 CE3057-4A- 1	Japan Aviation Electronics In- dustry, Ltd. Daiichi Denshi Kogyo K.K.

Connector on motor side already provided

To be selected if flexible conduit is used

Not required if flexible conduit is used

To be prepared by customer (cable)

	Motor Model	Receptacle	Plug	End Bell: Manufactured by Japan		Cable Clamp	Manufacturer
				Angle (L-Shaped)	Straight		
M o t o r	SGMD- 22A□A	JL04-2E24-10PE-B (MS3102A20-15P)	JL04V-6A24-10SE	JL04-24EBL	JL04-24EB	JL04-2428CK (17)	Japan Aviation Electronics Industry, Ltd.
	SGMD- 32A□A 40A□A	JL04-2E24-10PE-B (MS3102A20-15P)	JL04V-6A24-10SE	JL04-24EBL	JL04-24EB	JL04-2428CK (17)	Japan Aviation Electronics Industry, Ltd.
Detector		97F3102E20-29P (MS3102A20-29P)	MS3106A20-29S(D190)	CE-20BA-S	CE02-20BS-S	CE3057-12A-*	Daiichi Denshi Kogyo K.K.

Connector on motor side already provided

To be selected if flexible conduit is used

Not required if flexible conduit is used

To be prepared by customer (cable)

- * 1. The SGMG-55A□A, -75A□A, -1AA□A, 1EA□A, -44A□B, and -60A□B motors do not contain an End Bell. For these motors, use the following flexible conduit instead. Both L-shaped and straight type connectors are applicable to motors with a holding brake. (manufactured by Daiichi Denshi Kogyo K.K.).

Connector		Conduit Model	Manufacturer
Angle (L-Shaped)	Straight		
RCC-3**RL-MS32F	RCC-1**RL-MS32F	VF-** (SR-**)	NIPPON FLEX CO., LTD.

Select an appropriate connector and conduit model (mark **) according to the lead wire diameter. For details, refer to page 6 -175.

- Note: 1. The connectors for a detector are the same regardless of the motor model being used.
 2. To ensure compliance with IP67, always use the plug, End Bell, Back Shell and cable clamp specified above.
 3. Select an appropriate cable clamp model (mark **) according to the lead wire diameter. For details, refer to page 6 -175.
 4. () in the receptacle column shows the standard (non-dripproof) model. However, both are actually the same receptacles.

6.4.2 SERVOPACK Dimensional Drawings

The dimension drawings of the SERVOPACK can be grouped according to the heat sink attachment method and capacity.

Heat Sink Mounted Inside the Control Panel (cf. pp. 6 -139 to 6 -143)

- 0.2 to 1.5 kW Model: SGDB-02AM to -15AM
- 2.0 to 3.0 kW Model: SGDB-20AM to -30AM
- 5.0 to 7.5 kW Model: SGDB-50AM to -75AM
- 11 to 15 kW Model: SGDB-1AAM to -1EAM

Heat Sink Mounted Outside the Control Panel (cf. pp. 6 -144 to 6 -148)

- 0.2 to 1.5 kW Model: SGDB-02AM-P to -15AM-P
- 2.0 to 3.0 kW Model: SGDB-20AM-P to -30AM-P
- 5.0 to 7.5 kW Model: SGDB-50AM-P to -75AM-P
- 11 to 15 kW Model: SGDB-1AAM-P to -1EAM-P

■ Heat Sink Mounted Inside Control Panel

SGDB-02AM to -15AM (0.2 to 1.5 kW)

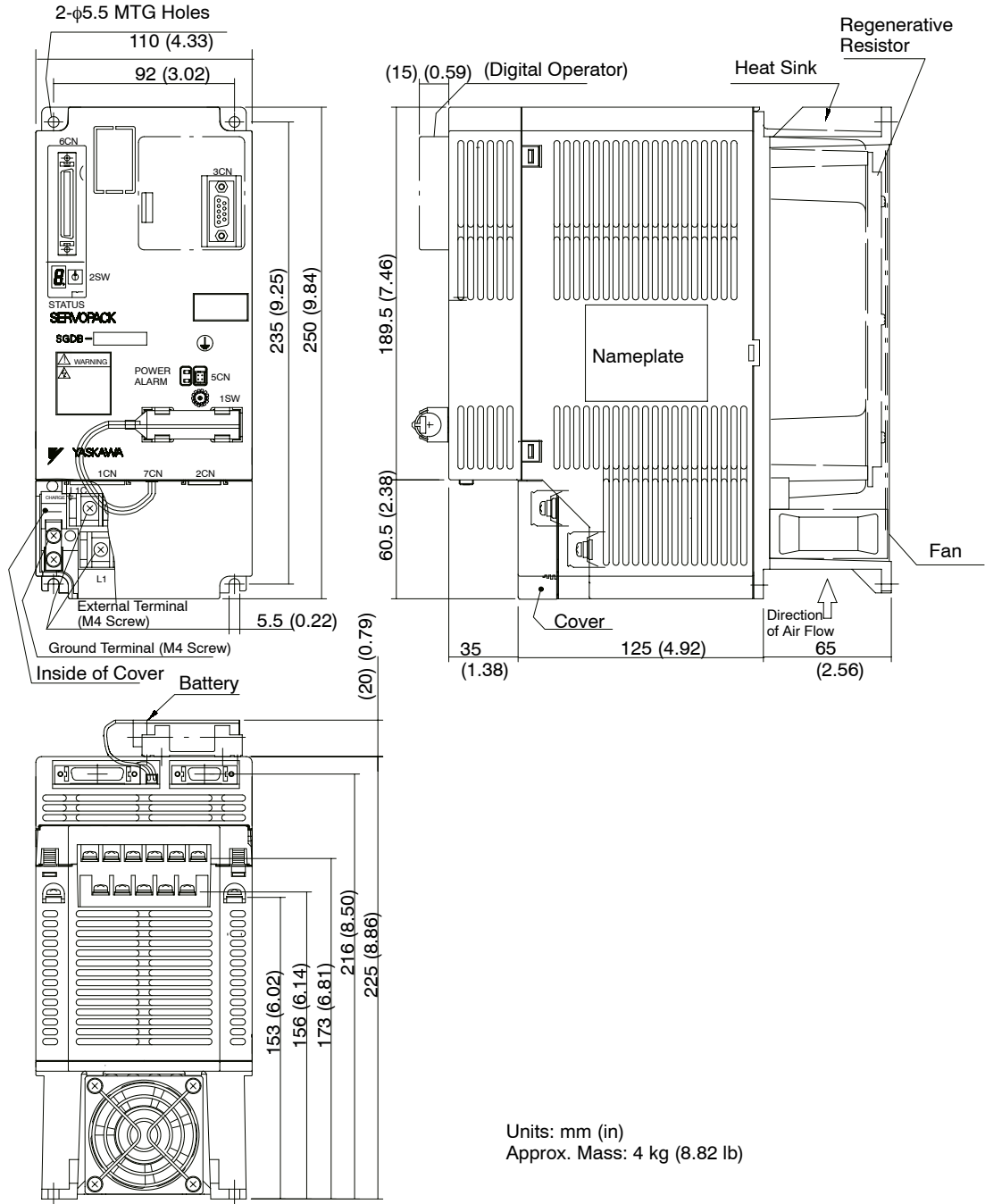

Units: mm (in)
Approx. Mass: 4 kg (8.82 lb)

The same connectors on the SERVOPACK end are used for models SGDB-02AM (0.2 kW) to SGDB-1EAM (15 kW).

Symbols	Connector on SERVOPACK End	Note
1CN	10236-52A2JL	Manufactured by 3M
2CN	10220-52A2JL	
3CN	17JE-13090-37 (D2B)	Manufactured by Daiichi Denshi Kogyo K.K.
5CN	DF11-4DP-2DSA	Manufactured by Hirose Denki
6CN	10250-6202JL	Manufactured by 3M

SGDB-20AM to -30AM (2.0 to 3.0 kW)

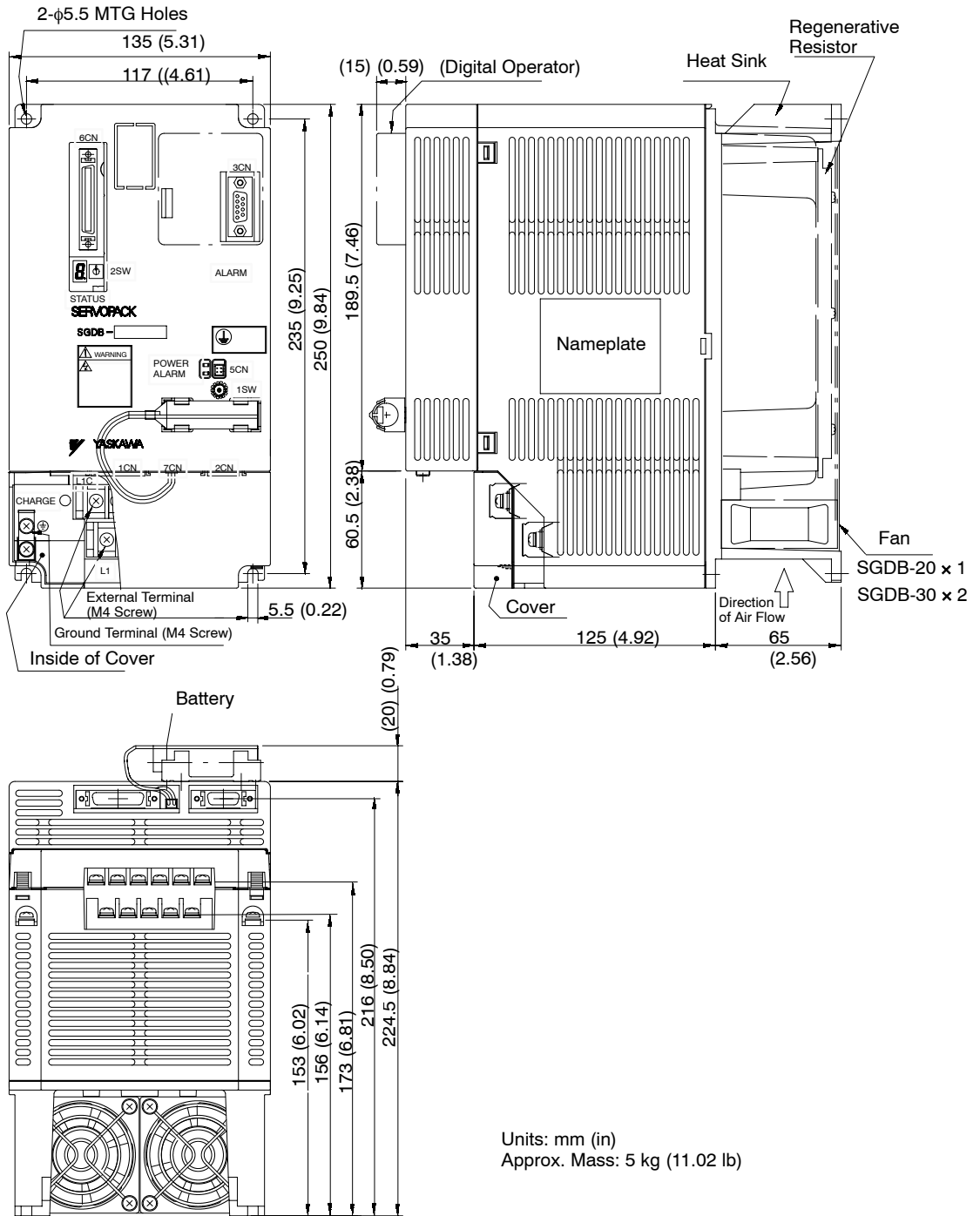

SGDB-50AM to -75AM (5.0 to 7.5 kW)

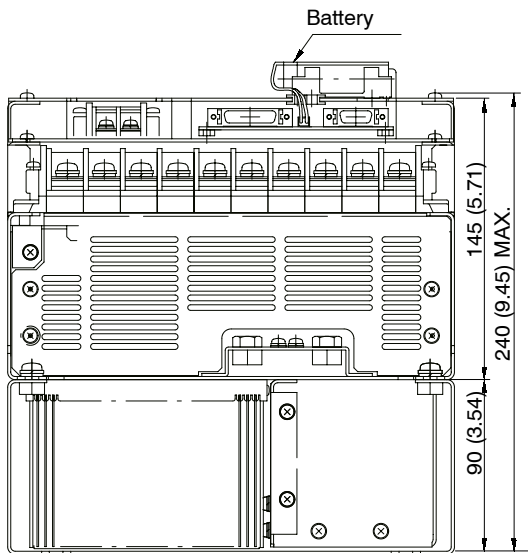
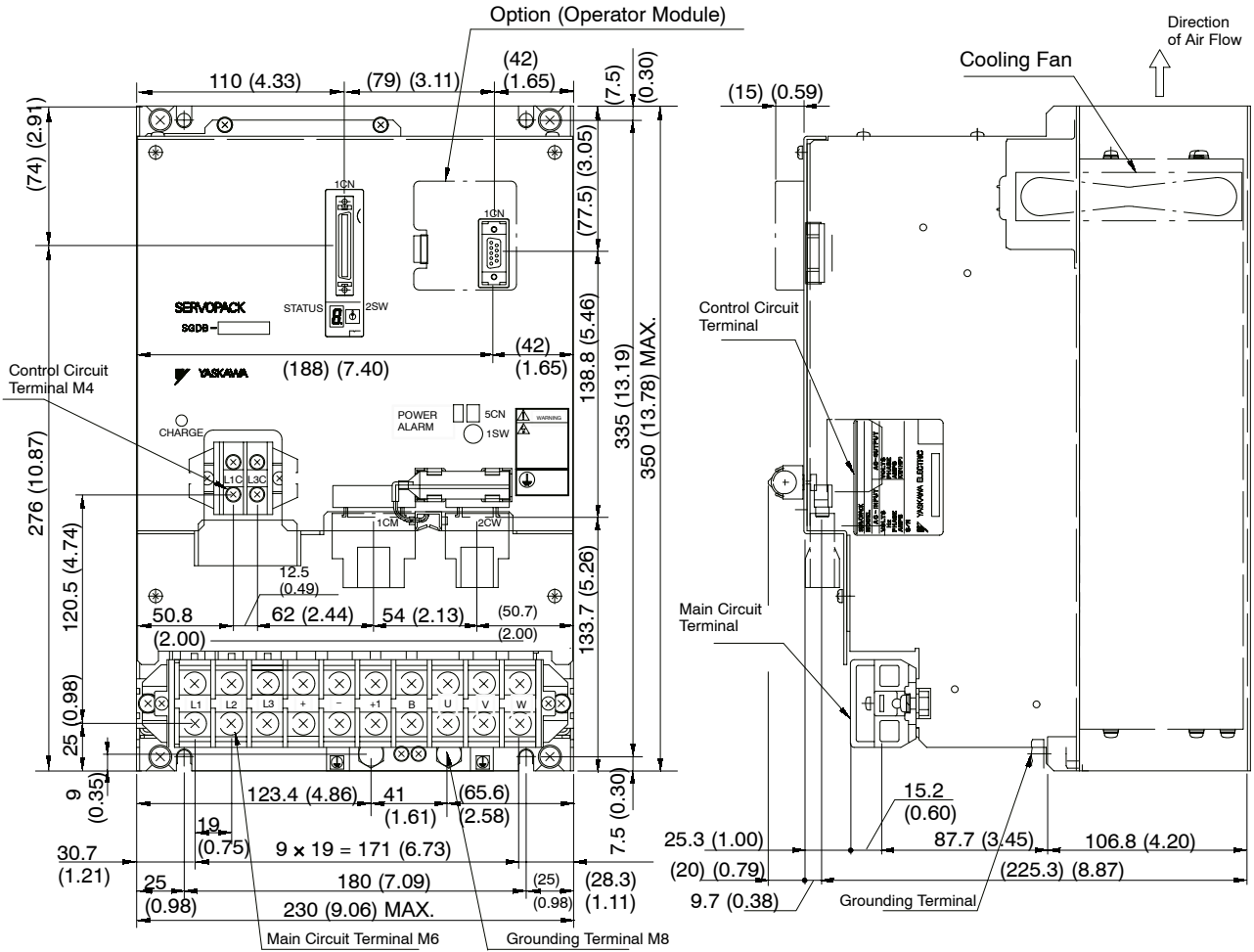

Units: mm (in)
Approx. Mass: 15 kg (33.07 lb)

SGDB-1AAM to -1EAM (11 to 15 kW)

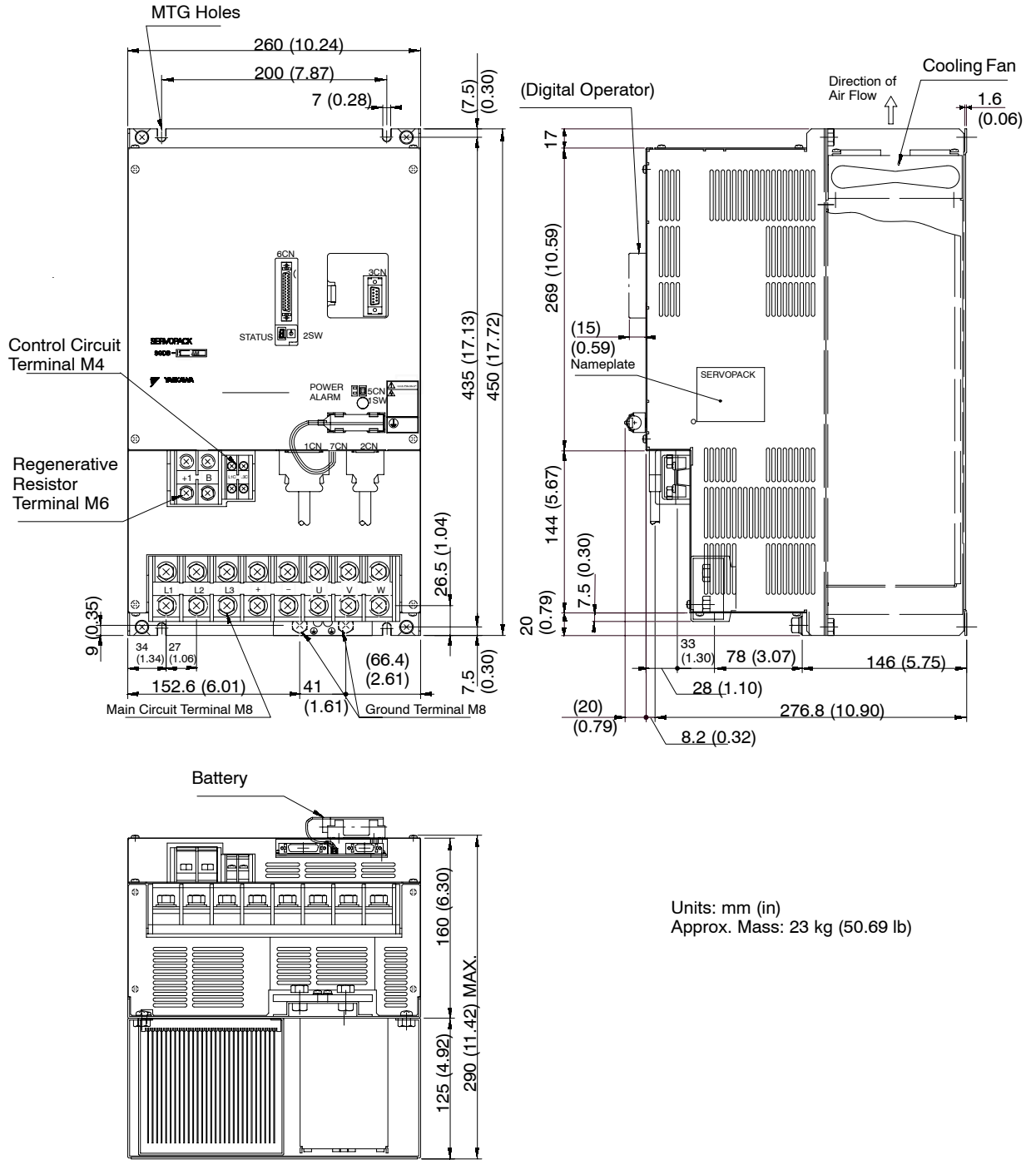

Units: mm (in)
Approx. Mass: 23 kg (50.69 lb)

■ Heat Sink Mounted Outside Control Panel

A duct ventilation model is available for SERVOPACKs that have a heat sink mounted outside the control panel.

This installation method has the following advantages.

- Heat generated inside the SERVOPACK control panel is discharged outside, reducing the buildup of heat inside the panel.
- The control panel in which the SERVOPACK is installed can remain compact.
- Connectors 1CN to 6CN:

When the heat sink is mounted outside the control panel, the same connectors on the SERVOPACK end are used for models SGDB-05AM-P to SGDB-1EAM-P.

Symbols	Connector on SERVOPACK End	Note
1CN	10236-52A2JL	Manufactured by 3M
2CN	10220-52A2JL	
3CN	17JE-13090-37 (D2B)	Manufactured by Daiichi Denshi Kogyo K.K.
5CN	DF11-4DP-2DSA	Manufactured by Hirose Denki
6CN	10250-6202JL	Manufactured by 3M

SGDB-02AM-P to -15AM-P

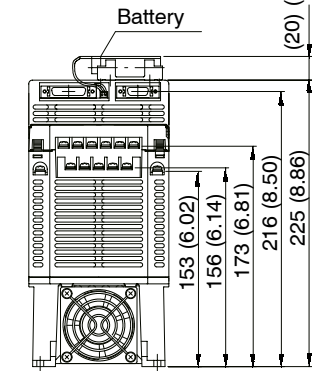
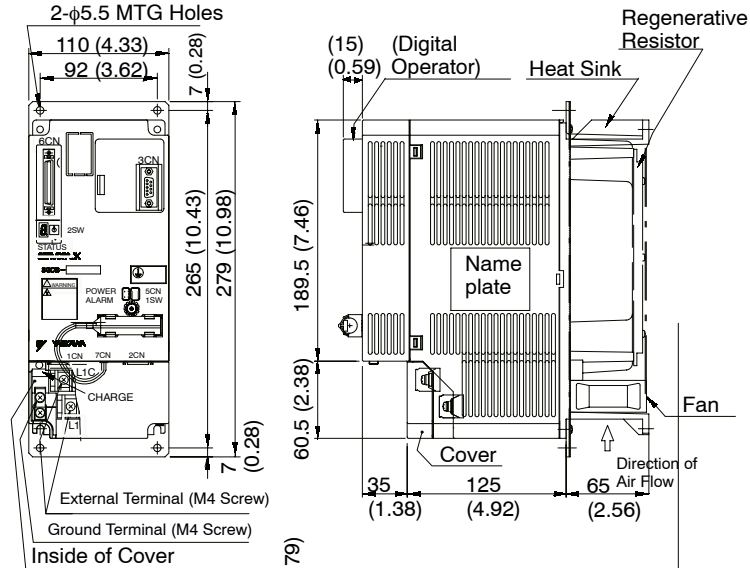

Units: mm (in)
Approx. Mass: 4 kg (8.82 lb)

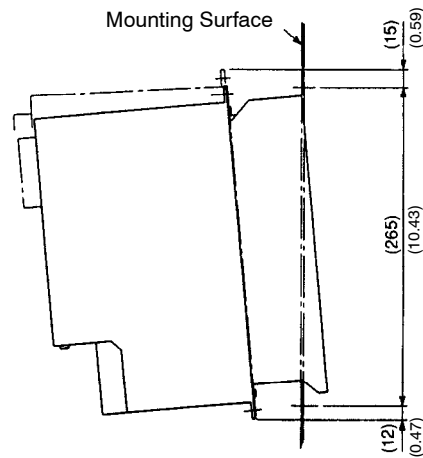
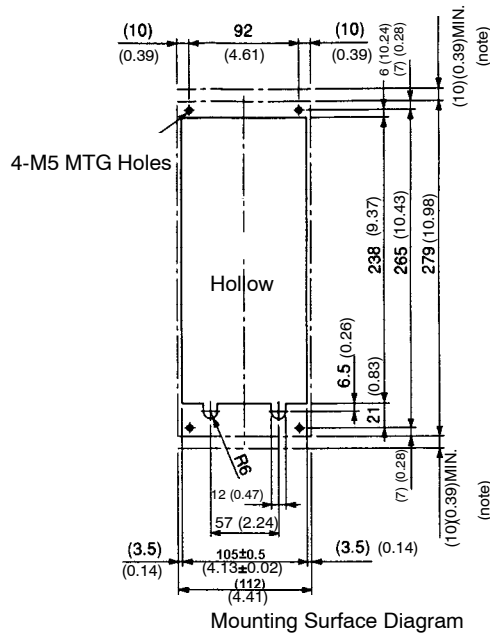

Note: When mounting, the SERVOPACK must be inclined as shown in the above figure. Provide at least 10 mm (0.39 in.) clearance above and below the SERVOPACK.

SGDB-20AM-P to -30AM-P

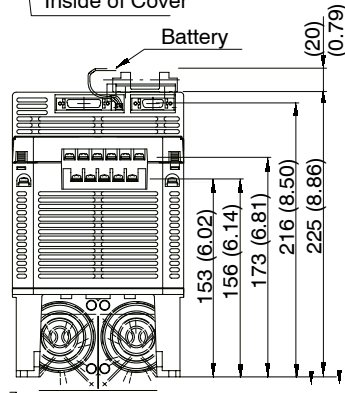
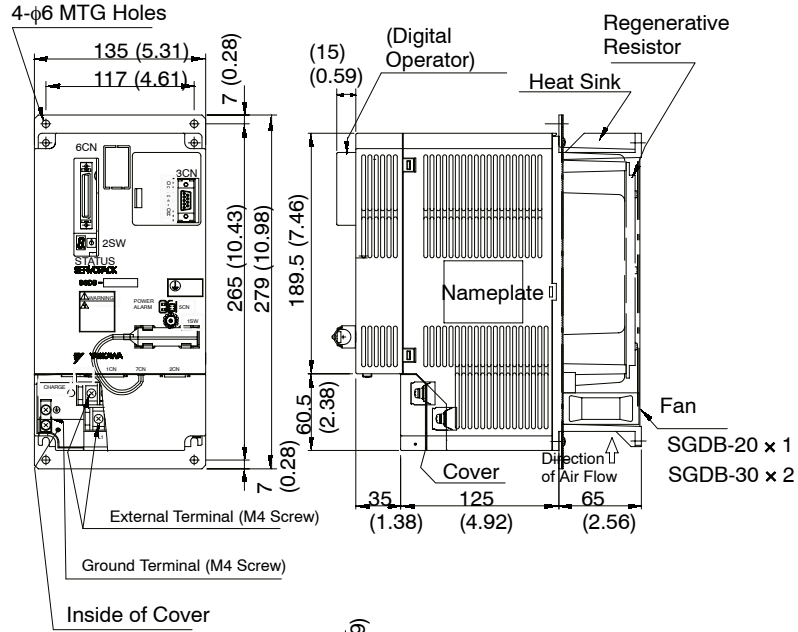

Units: mm (in)
Approx. Mass: 5 kg (11.02 lb)

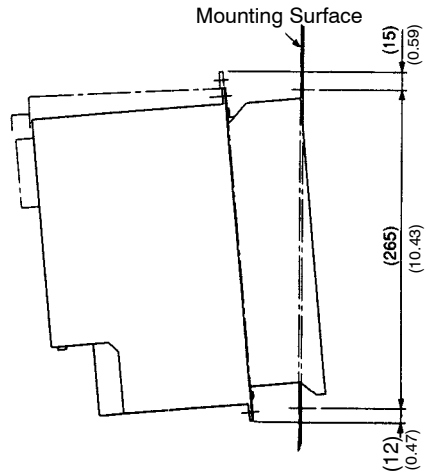
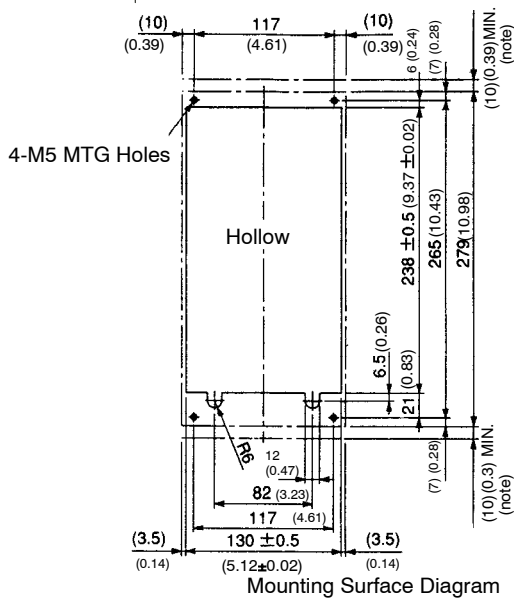

Note: When mounting, the SERVOPACK must be inclined as shown in the above figure. Provide at least 10 mm (0.39 in.) clearance above and below the SERVOPACK.

SGDB-50AM-P to -75AM-P

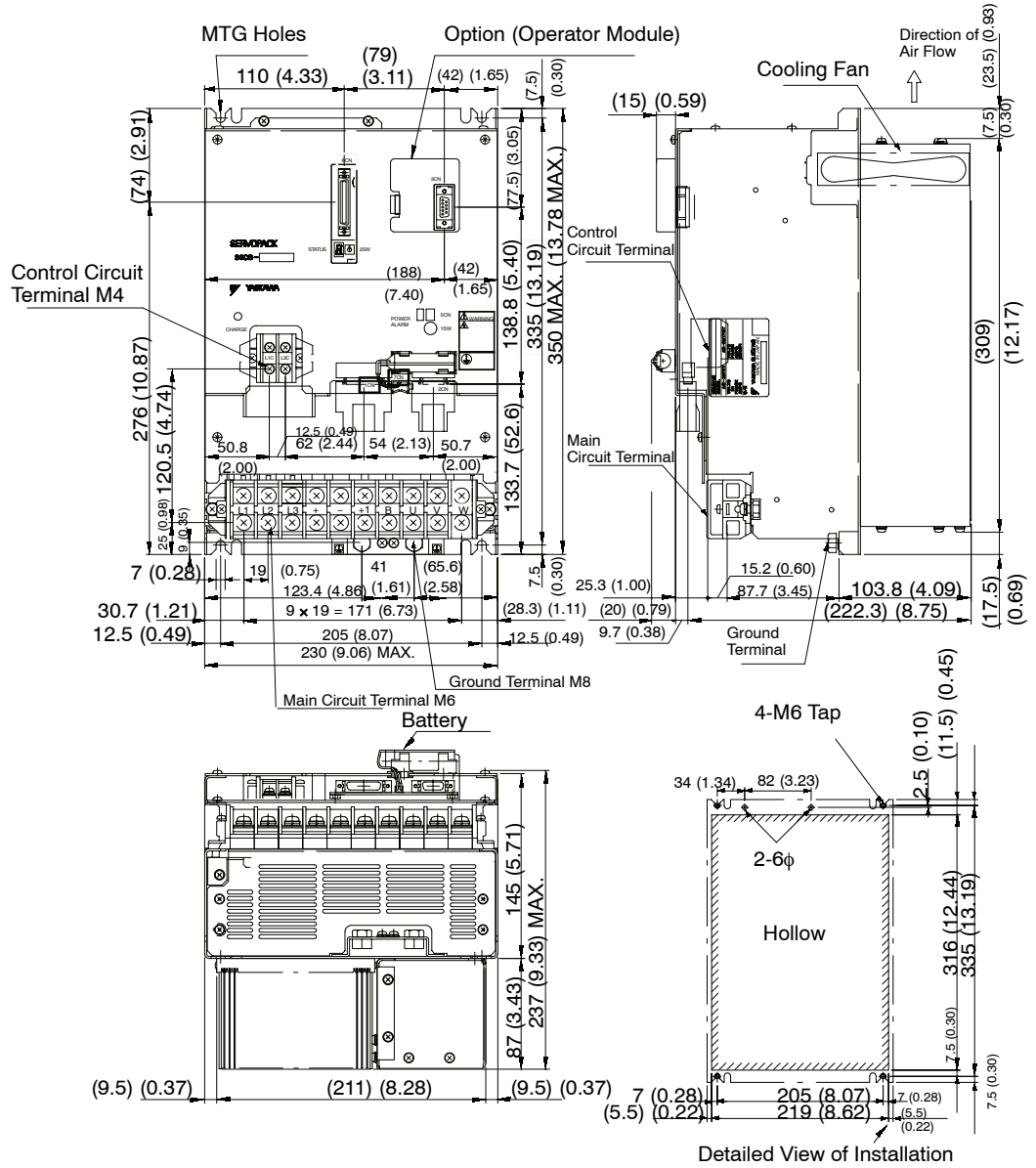

Units: mm (in)
 Approx. Mass: 15.5 kg (34.16 lb)

SGDB-1AAM-P and -1EAM-P

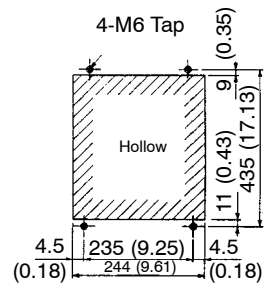
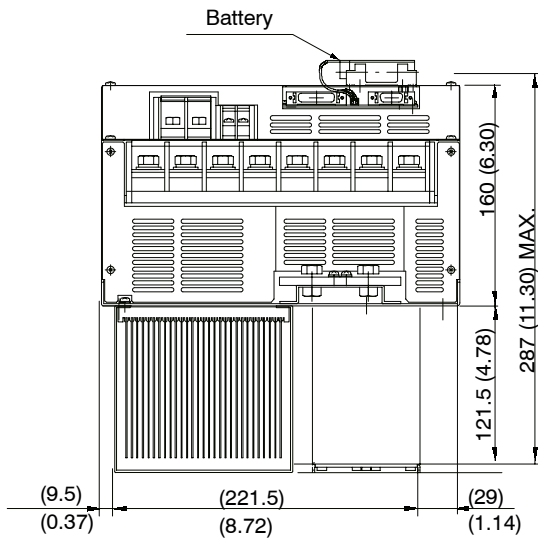
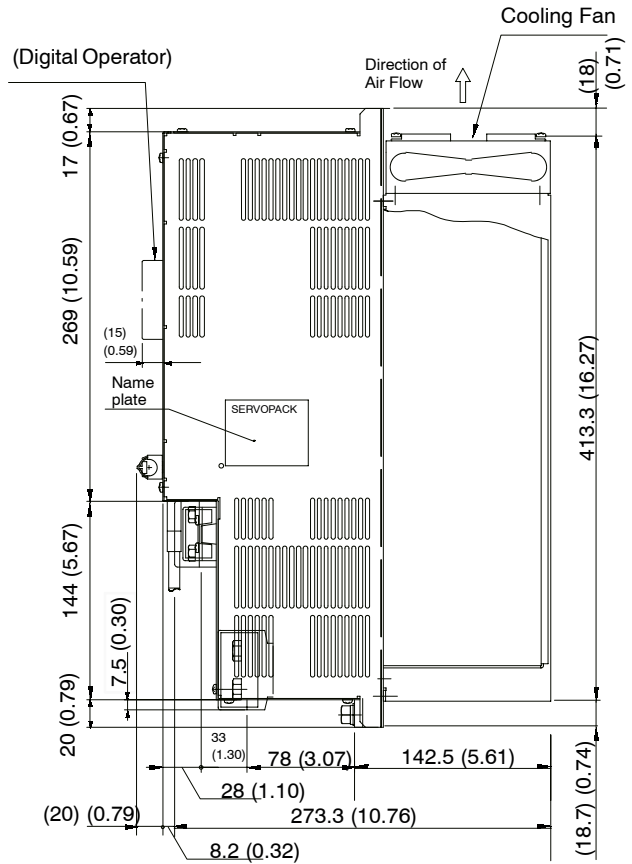
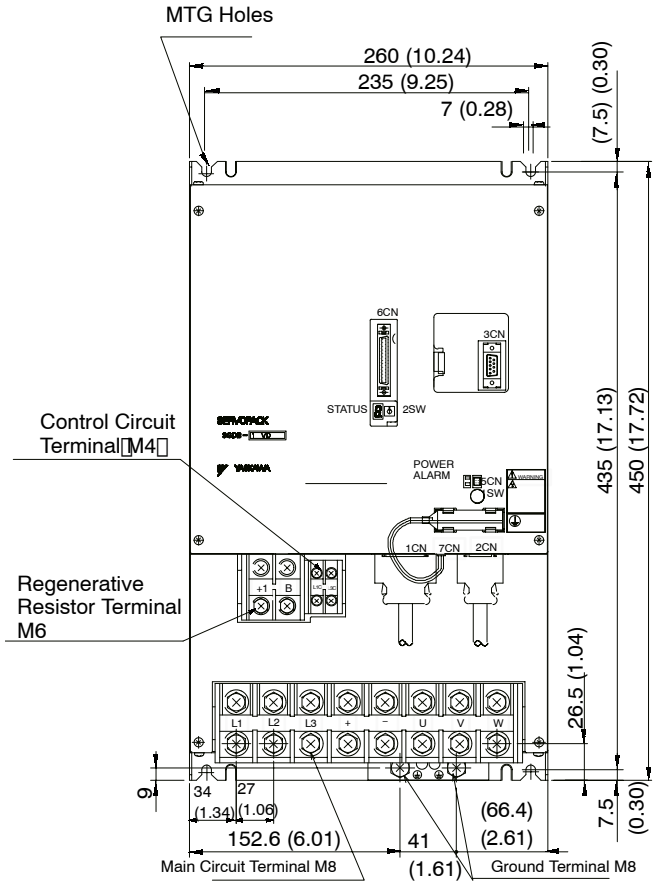

Detailed View of Installation

Units: mm (in)
Approx. Mass: 22 kg (48.49 lb)

6.4.3 Digital Operator Dimensional Drawings

The following two models of Digital Operator are available.

JUSP-OP02A-1 (Hand-held)

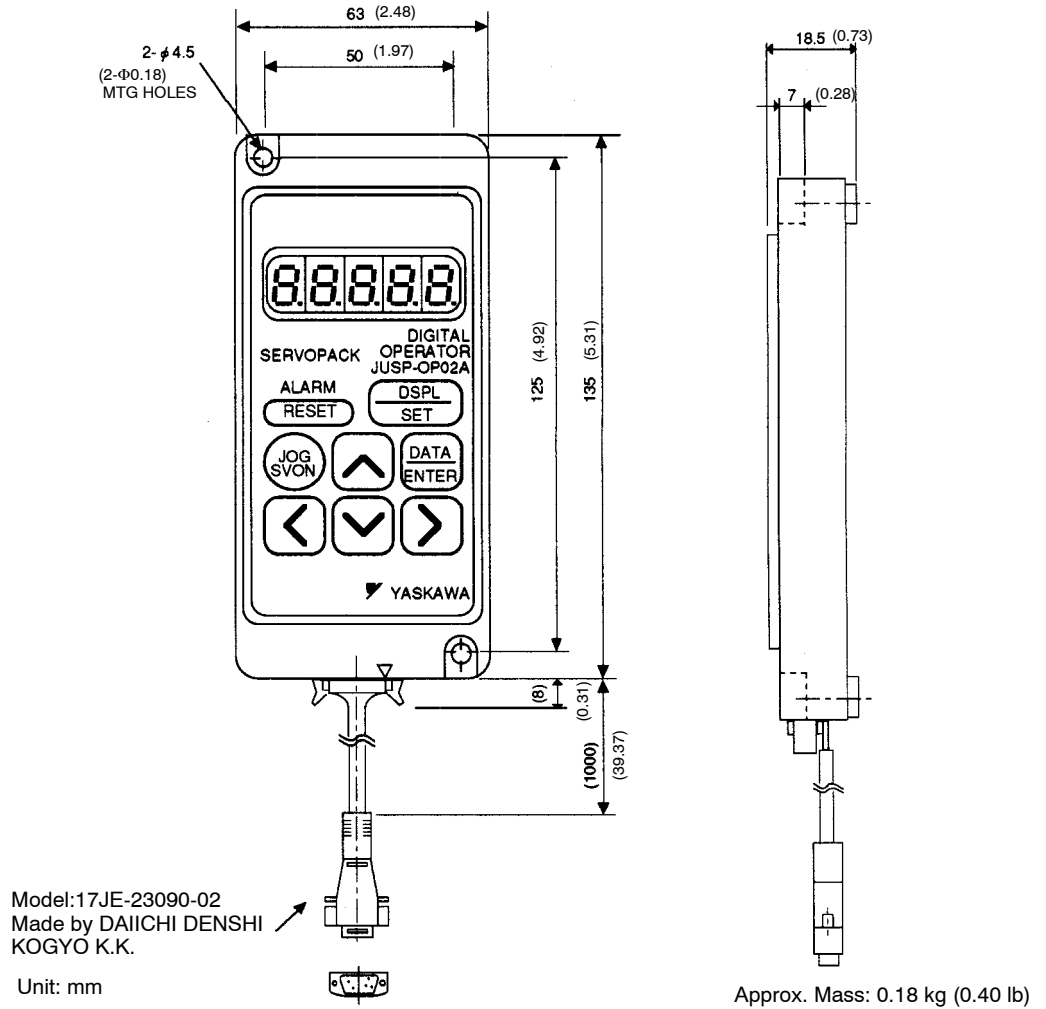

JUSP-OP03A (Mounted)

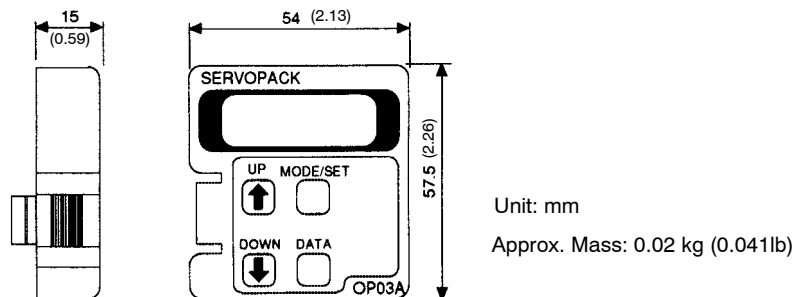

6.5 Selecting Peripheral Devices

This section shows how to select peripheral devices using flowcharts. Order lists for Servomotors, SERVOPACKs, Digital Operators, and peripheral devices are also included.

6.5.1 Selecting Peripheral Devices

Select the peripheral devices using the flowcharts on the subsequent pages.

The items below are not included in the flowcharts. Refer to *6.6 Specifications and Dimensional Drawings of Peripheral Devices*.

- Encoder signal converter units
- Cables for connecting PC and SERVOPACK

Flowchart for Peripheral Device Selection

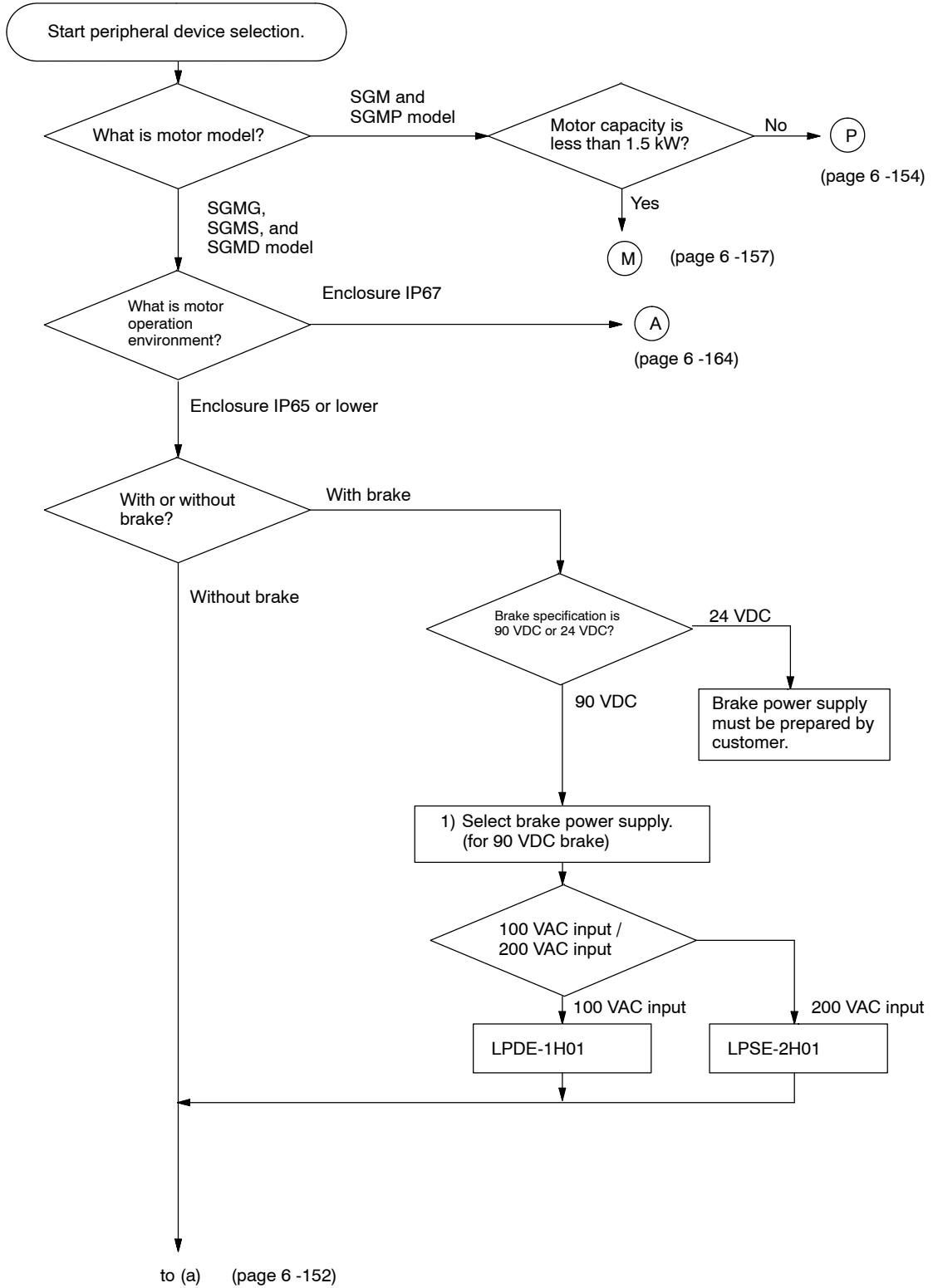

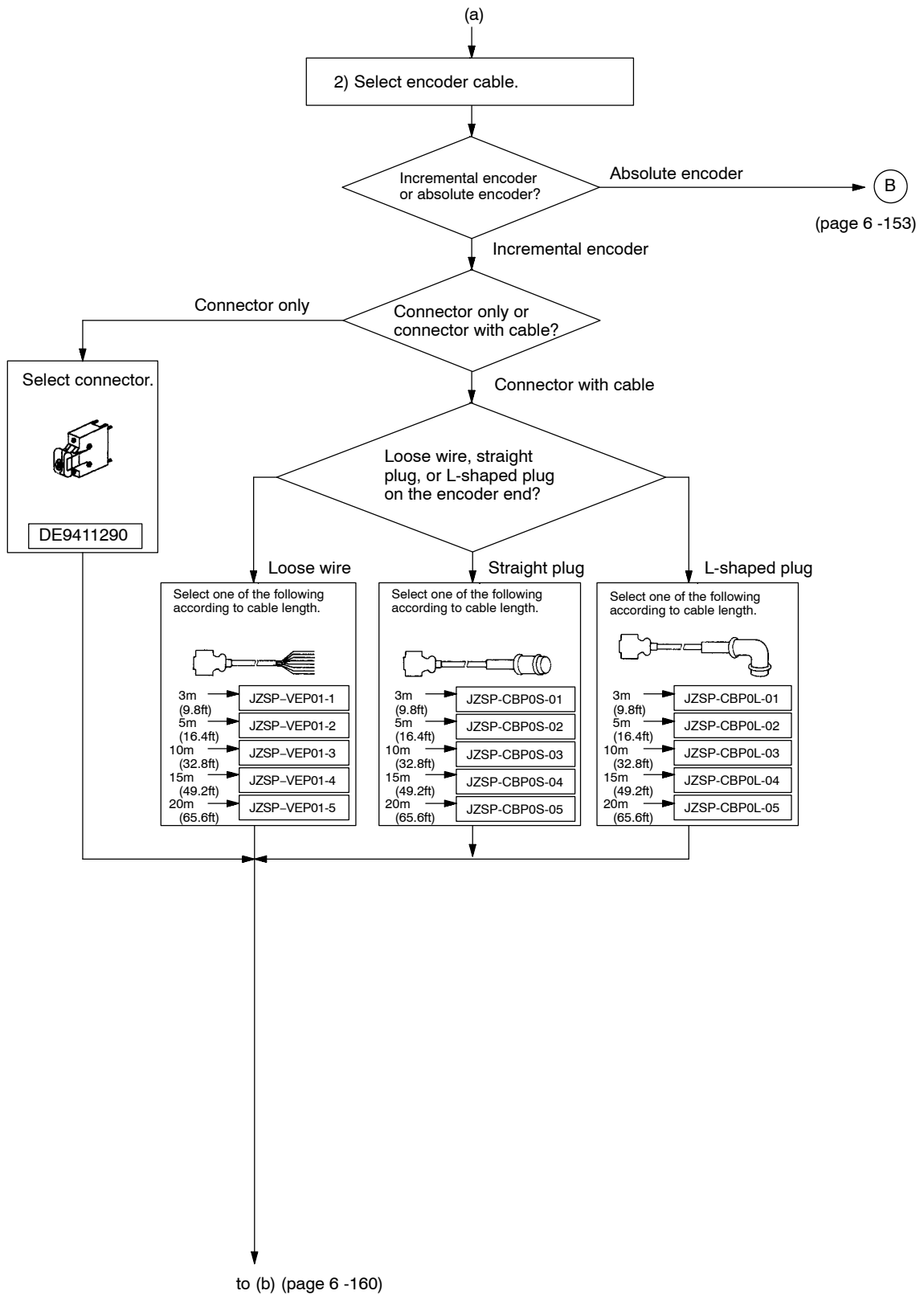

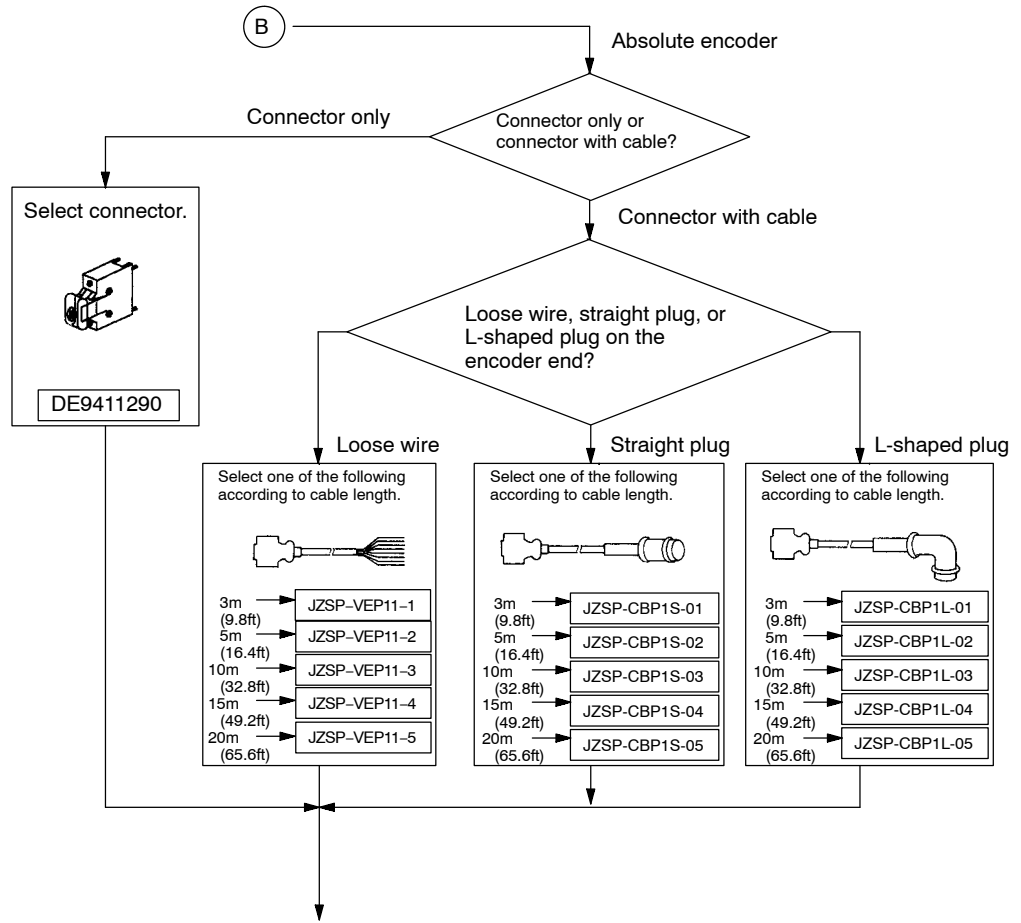

to (b) (page 6 -160)

6.5.1 Selecting Peripheral Devices

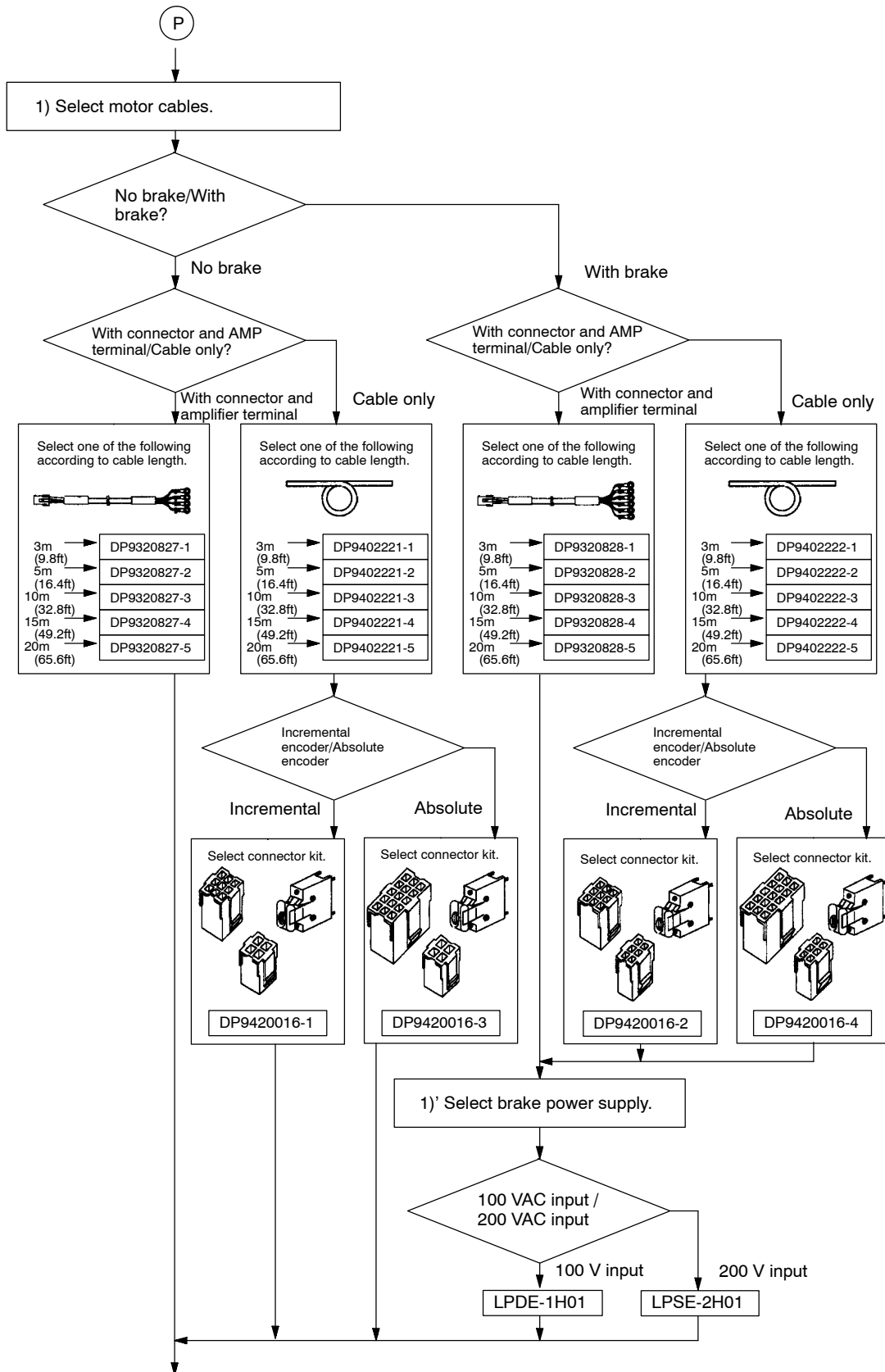

6

to (a)' (page 6 -155)

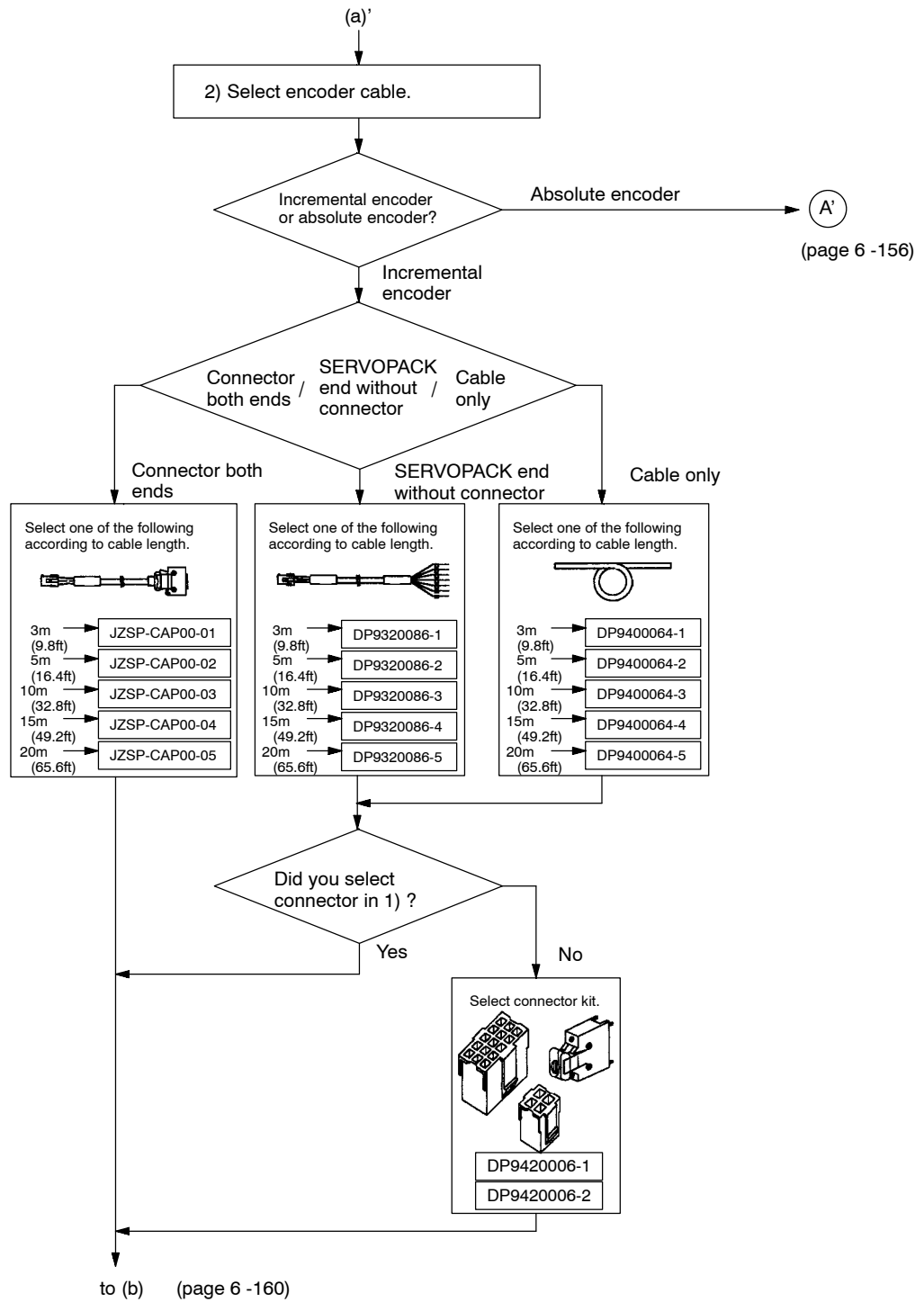

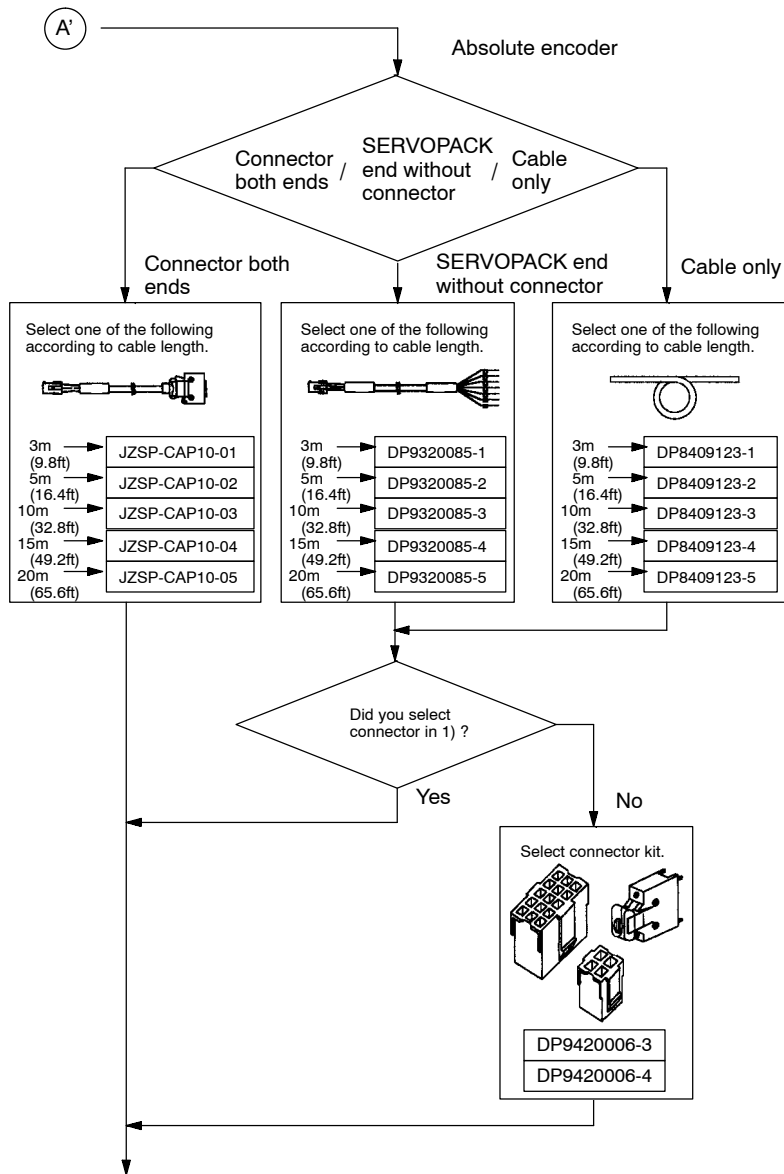

to (b) (page 6 -160)

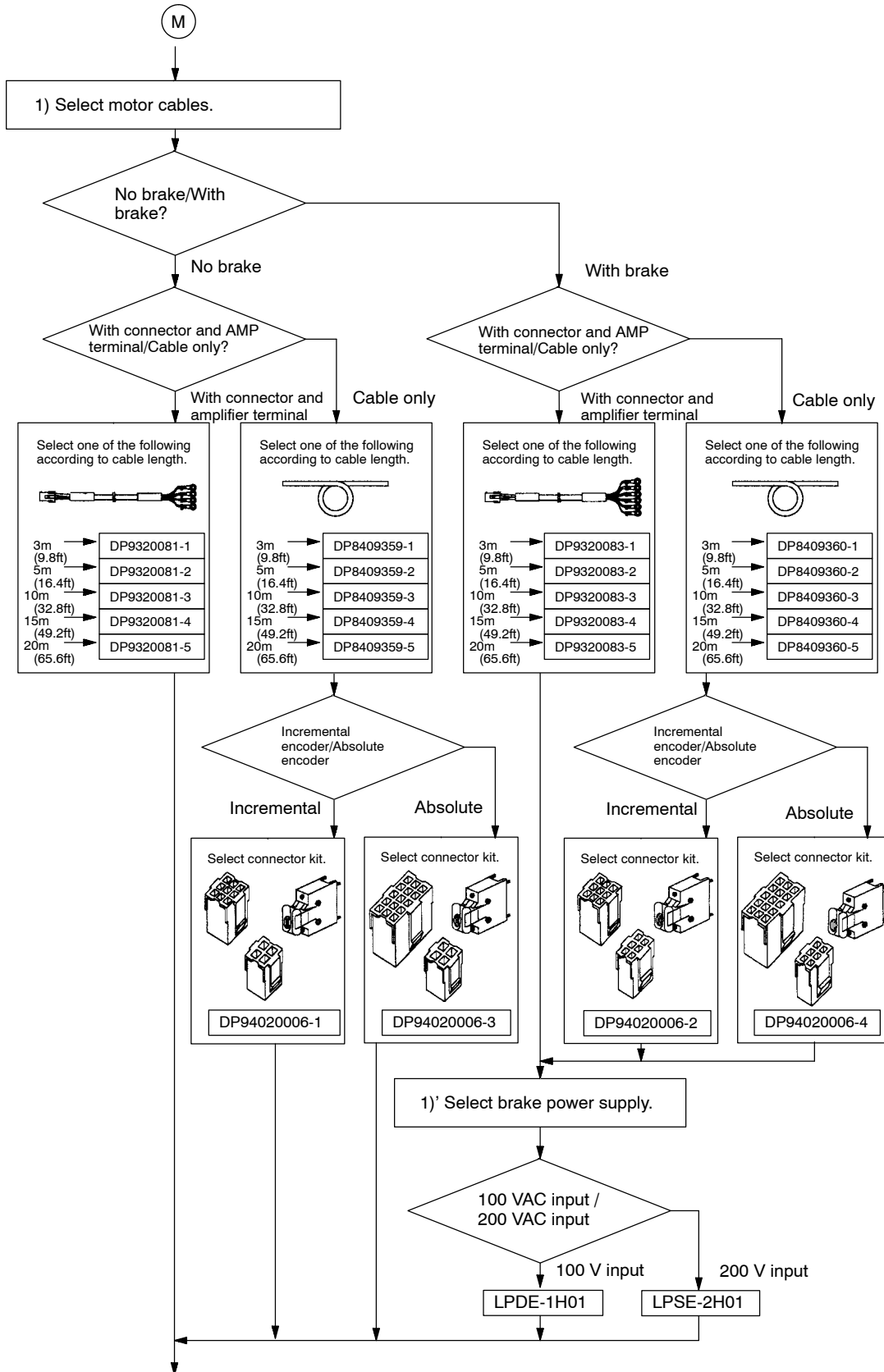

to (a)'' (page 6 -158)

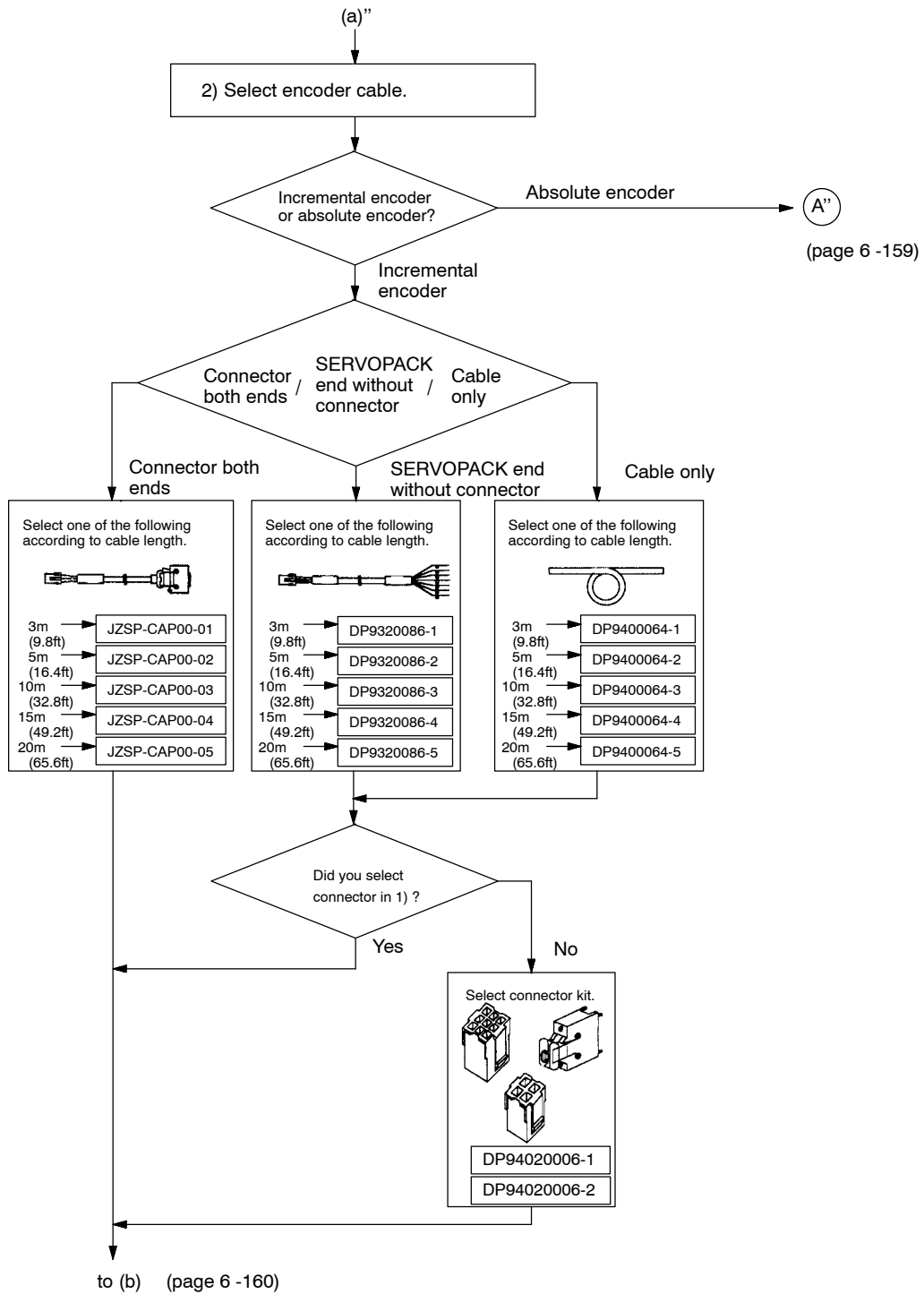

6

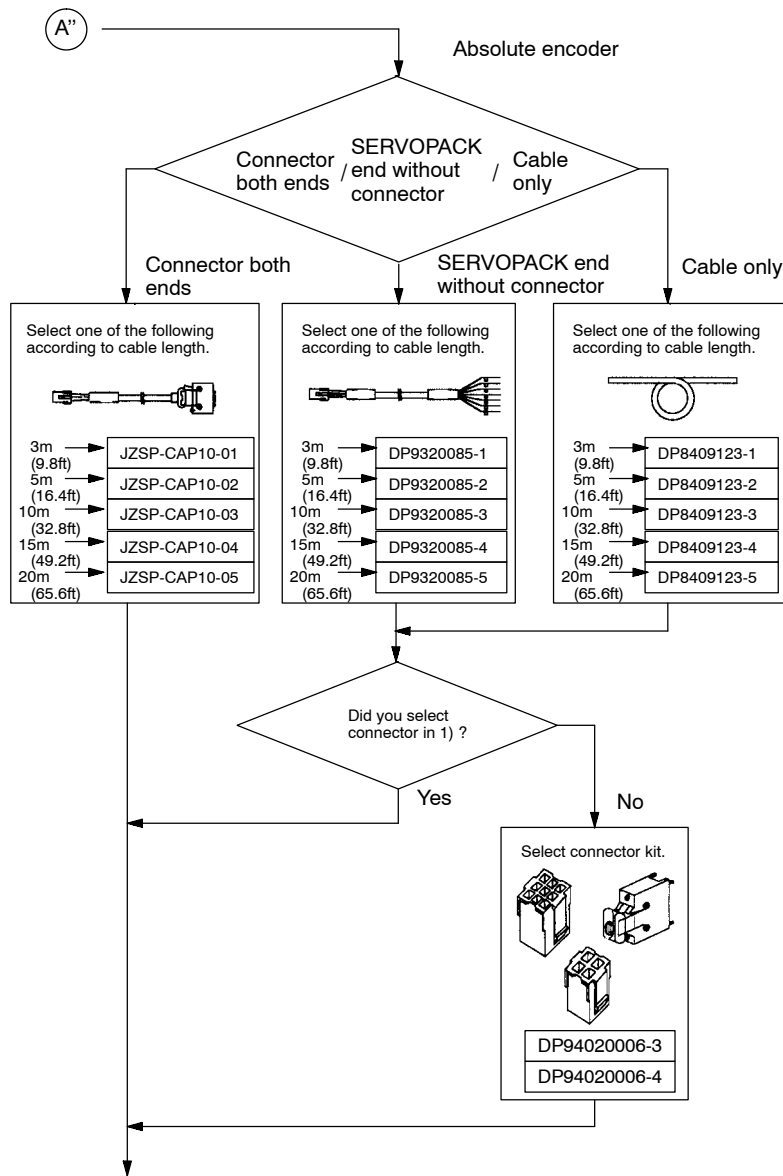

6.5.1 Selecting Peripheral Devices

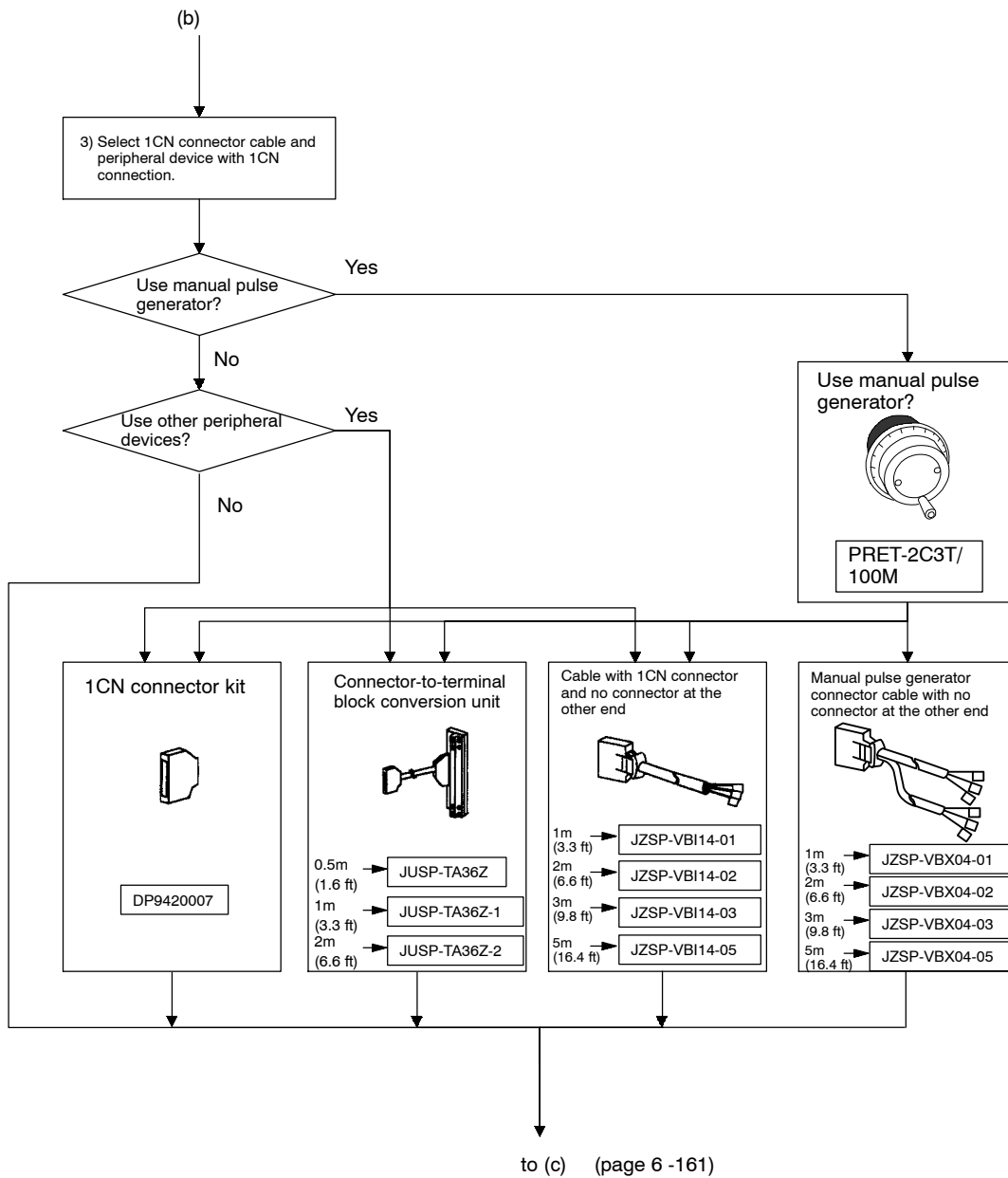

6

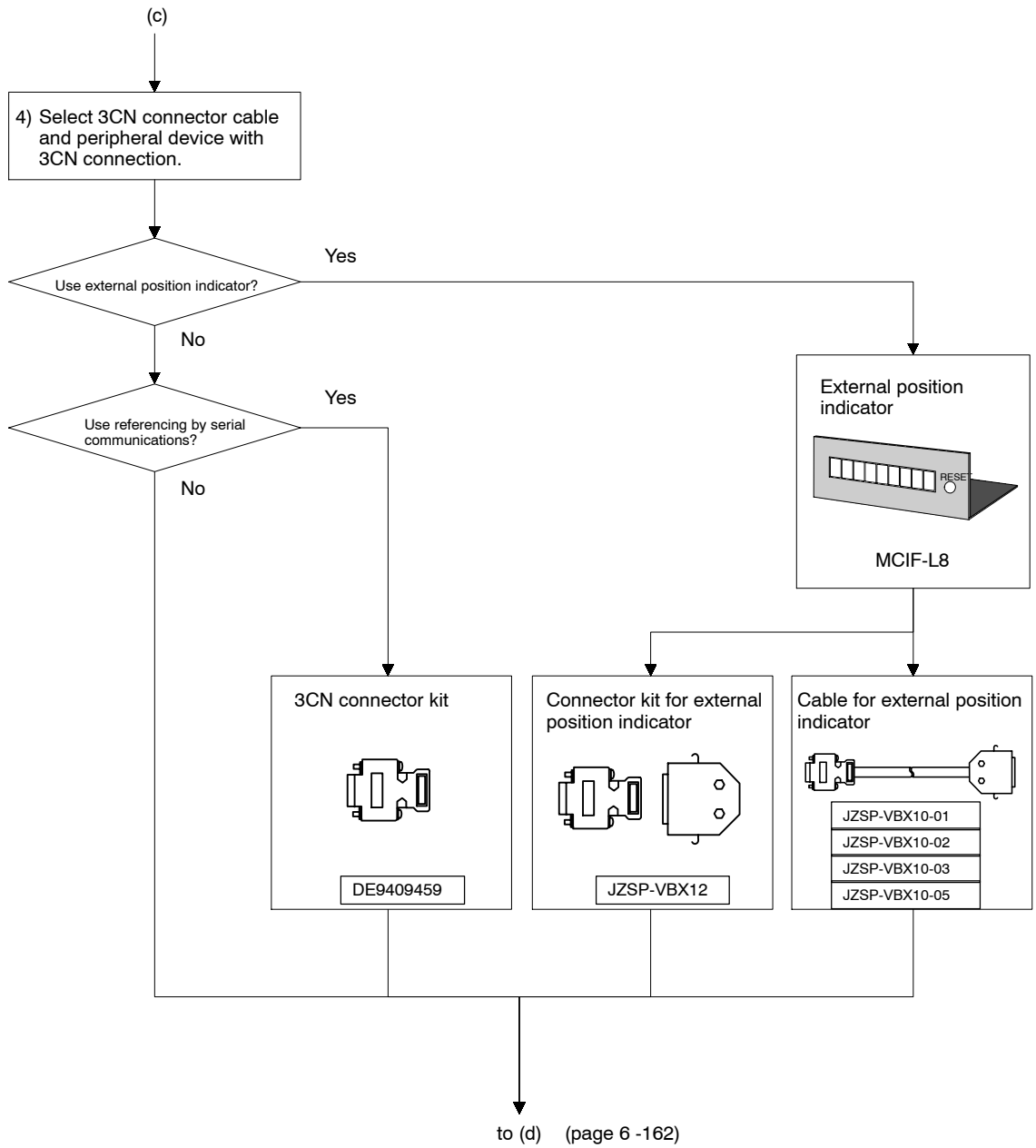

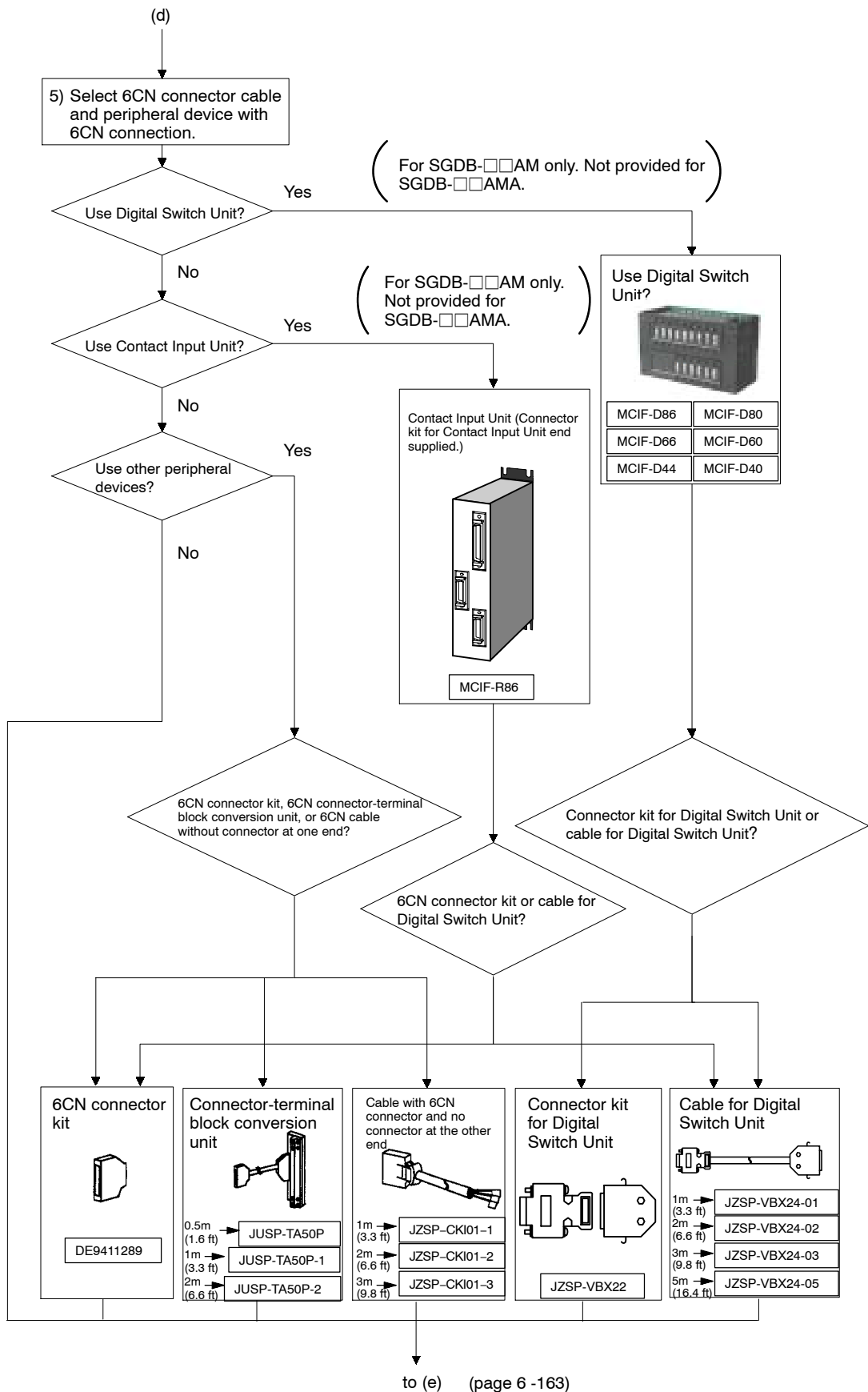

6

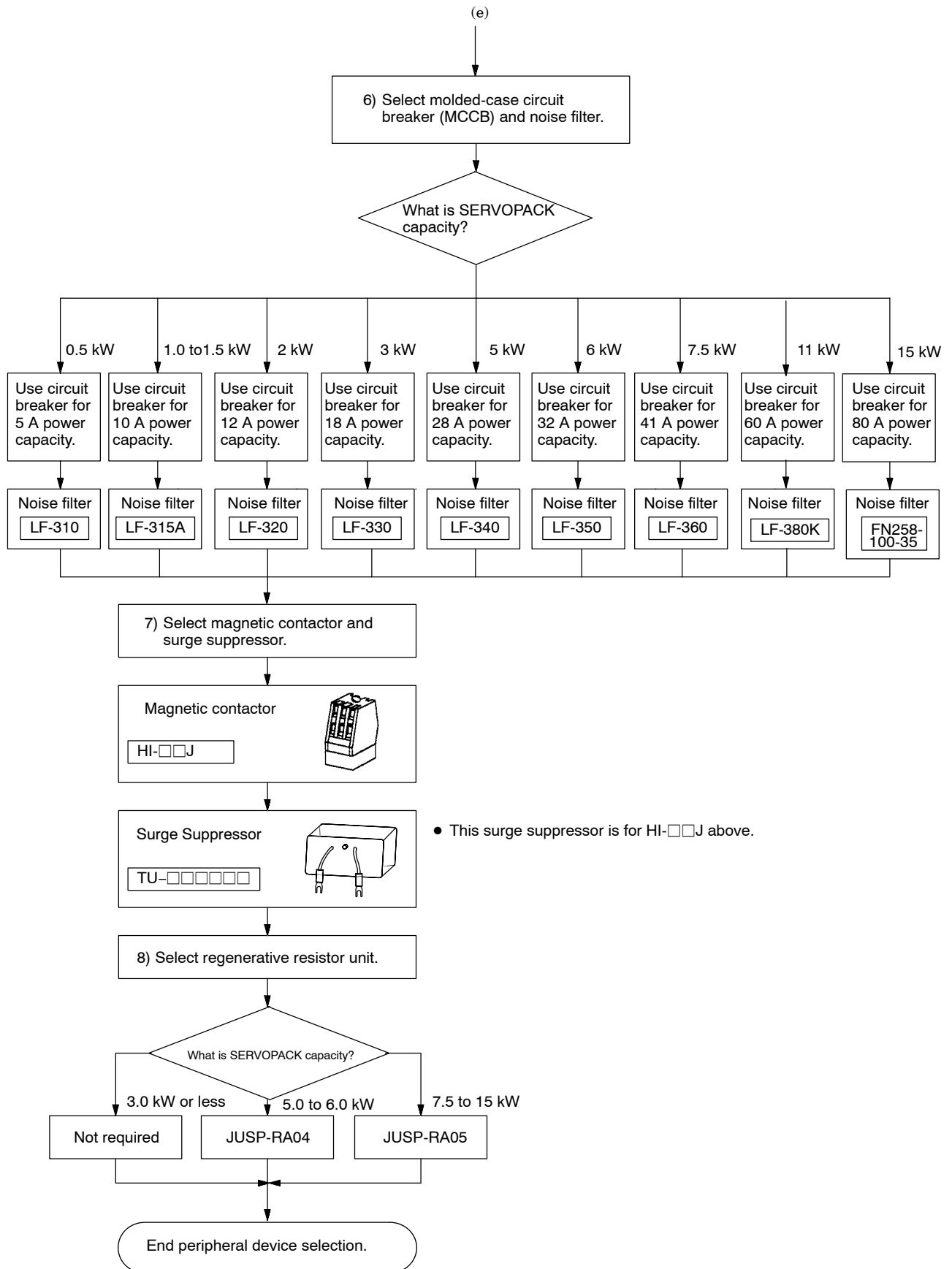

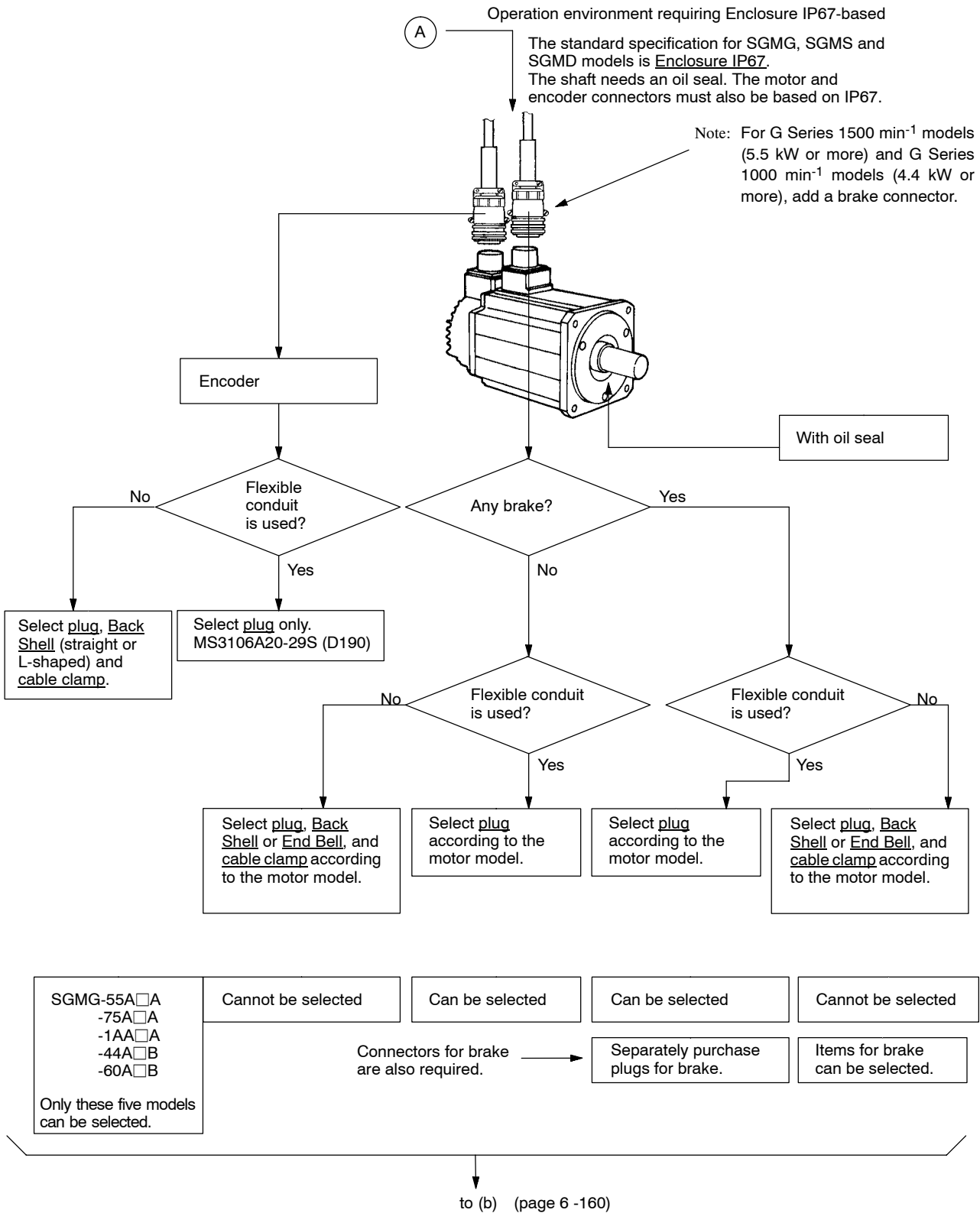

Note: 1. Power cable and flexible conduit must be prepared by the customer.

2. The customer must purchase an appropriate encoder cable according to the encoder model (incremental or absolute encoder) and an encoder connector kit (for the SERVOPACK end), and assemble them.

6.5.2 Order List

Order lists are given below for the Servomotors, SERVOPACKs, Digital Operators, and peripheral devices which comprise the AC Servo Σ -Series. These order lists are a convenient aid to selecting peripheral devices.

■ SGM□ Servomotor

Servomotor Model	Qty
SGM□-□□□□□□□□	
SGM□-□□□□□□□□	
SGM□-□□□□□□□□	
SGM□-□□□□□□□□	
SGM□-□□□□□□□□	
SGM□-□□□□□□□□	
SGM□-□□□□□□□□	
SGM□-□□□□□□□□	
SGM□-□□□□□□□□	
SGM□-□□□□□□□□	
SGM□-□□□□□□□□	
SGM□-□□□□□□□□	
SGM□-□□□□□□□□	

■ SGDB SERVOPACK

SGDB SERVOPACKs have no cables or connectors. They must be purchased separately.

SERVOPACK Model	Qty
SGDB-□□□□□	
SGDB-□□□□□	
SGDB-□□□□□	
SGDB-□□□□□	
SGDB-□□□□□	
SGDB-□□□□□	

■ Digital Operator

A Digital Operator is not included in SERVOPACKs. It must be purchased separately.

Digital Operator Model	Qty
JUSP-OP02A-1	
JUSP-OP03A	

■ Peripheral Devices

Order lists are given below for connectors, cables, and brake power supply units. They are different between SGMG/SGMS/SGMD and SGMP-15A Servomotors.

For SGM, SGMS, SGMD Servomotors

- Connectors

Main Circuit Connectors on Motor End (without Brake)

Each connector consists of a plug and a cable clamp.

(Purchase Separately)

Motor Model	Connectors on Motor End				Qty
	Plug		Cable Clamp	Receptacle*	
	L-shaped	Straight			
SGMS- 10A□A 15A□A 20A□A 30A□A 40A□A 50A□A	MS3108B18-10S	MS3106B18-10S	MS3057-10A	MS3102A18-10P	
	MS3108B22-22S	MS3106B22-22S			
SGMG- 05A□A 09A□A 13A□A 20A□A 30A□A 44A□A 55A□A 75A□A 1AA□A 1EA□A	MS3108B18-10S	MS3106B18-10S	MS3057-10A	MS3102A18-10P	
	MS3108B22-22S	MS3106B22-22S			
	MS3108B32-17S	MS3106B32-17S	MS3057-20A	MS3102A32-17P	

To be prepared by customer (cable)

* Connector on motor end already provided.

Motor Model	Connectors on Motor End				Qty
	Plug		Cable Clamp	Receptacle*	
	L-shaped	Straight			
SGMG- 03A□B 06A□B 09A□B	MS3108B18-10S	MS3106B18-10S	MS3057-10A	MS3102A18-10P	
	MS3108B22-22S	MS3106B22-22S	MS3057-12A	MS3102A22-22P	
	MS3108B32-17S	MS3106B32-17S	MS3057-20A	MS3102A32-17P	
SGMD- 22A□A 32A□A 40A□A	MS3108B24-10S	MS3106B24-10S	MS3057-16A	MS3102A24-10P	

To be prepared by customer (cable)

* Connector on motor end already provided.

Main Circuit Connectors on Motor End (with Brake)

Each connector consists of a plug and a cable clamp.

(Purchase Separately)

Motor Model	Connectors on Motor End (with Brake)				Qty
	Plug		Cable Clamp	Receptacle*	
	L-shaped	Straight			
SGMS- 10A□A 15A□A 20A□A	MS3108B20-15S	MS3106B20-15S	MS3057-12A	MS3102A20-15P	

To be prepared by customer (cable)

* Connector on motor end already provided.

Motor Model	Connectors on Motor End (with Brake)				Qty
	Plug		Cable Clamp	Receptacle*	
	L-shaped	Straight			
SGMS- 30A□A 40A□A 50A□A	MS3108B24-10S	MS3106B24-10S	MS3057-16A	MS3102A24-10P	
SGMG- 05A□A 09A□A 13A□A	MS3108B20-15S	MS3106B20-15S	MS3057-12A	MS3102A20-15P	
20A□A 30A□A 44A□A	MS3108B24-10S	MS3106B24-10S	MS3057-16A	MS3102A24-10P	
55A□A 75A□A 1AA□A 1EA□A	MS3108B32-17S MS3108B10SL-3S	MS3106B32-17S MS3106A10SL-3S	MS3057-20A MS3057-4A	MS3102A32-17P MS3102A10SL-3P	
SGMG- 03A□B 06A□B 09A□B	MS3108B20-15S	MS3106B20-15S	MS3057-12A	MS3102A20-15P	
12A□B 20A□B 30A□B	MS3108B24-10S	MS3106B24-10S	MS3057-16A	MS3102A24-10P	
44A□B 60A□B	MS3108B32-17S MS3108B10SL-3S	MS3106B32-17S MS3106A10SL-3S	MS3057-20A MS3057-4A	MS3102A32-17P MS3102A10SL-3P	
SGMD- 22A□A 32A□A 40A□A	MS3108B24-10S	MS3106B24-10S	MS3057-16A	MS3102A24-10P	

To be prepared by customer (cable)

* Connector on motor end already provided.

Encoder Connectors on Motor End

Each connector consists of a plug and a cable clamp.

(Purchase Separately)

Connectors on Encoder End				Qty
Plug		Cable Clamp	Receptacle*	
L-shaped	Straight			
MS3108B20-29S	MS3106B20-29S	MS3057-12A	MS3102A20-29P	

To be prepared by customer (cable)

* Connector on motor end already provided.

Encoder Connector Kit on SERVOPACK End (for 2CN)

This connector kit consists of a connector and a case.

(Purchase Separately)

Connector Kit on SERVOPACK End	Connector Kit				Qty
	Connector		Case		
	Model	Qty	Model	Qty	
DE9406973	10120-3000VE*	1	10320-52A0-008*	1	

* Manufactured by 3M

Enclosure IP67 Main Circuit Connectors on Motor End (without Brake)

(Purchase Separately)

Motor Model	Receptacle	Plug	End Bell: Manufactured by Japan Aviation Electronics Industry, Ltd. Back Shell: Manufactured by Daiichi Denshi Kogyo K.K.		Cable Clamp	Manufacturer	Qty
			Angle (L-shaped)	Straight			
SGMS- 10A□A 15A□A 20A□A 30A□A 40A□A 50A□A	CE05-2A18-10PD	MS3106A18-10S (D190)	CE-18BA-S	CE02-18BS-S	CE3057-10A-*	Daiichi Denshi Kogyo K.K.	
	JL04HV-2E22-22PE-B	JL04V-6A22-22SE	JL04-22EBL	JL04-22EB	JL04-2022CK (14)	Japan Aviation Electronics Industry, Ltd.	
SGMG- 05A□A 09A□A 13A□A 20A□A 30A□A 44A□A 55A□A 75A□A 1AA□A 1EA□A	CE05-2A18-10PD	MS3106A18-10S (D190)	CE-18BA-S	CE02-18BS-S	CE3057-10A-*	Daiichi Denshi Kogyo K.K.	
	JL04HV-2E22-22PE-B	JL04V-6A22-22SE	JL04-22EBL	JL04-22EB	JL04-2022CK (14)	Japan Aviation Electronics Industry, Ltd.	
	JL04V-2E32-17PE-B	JL04V-6A32-17SE	-	-	-	Daiichi Denshi Kogyo K.K.	

Connector on motor end already provided

To be selected if flexible conduit is used

Not required if flexible conduit is used

To be prepared by customer (cable)

* Select an appropriate model according to the lead wire diameter. Refer to *IP67-based Encoder Connectors on Motor End*.

Motor Model	Receptacle	Plug	End Bell: Manufactured by Japan Aviation Electronics Industry, Ltd. Back Shell: Manufactured by Daiichi Denshi Kogyo K.K.		Cable Clamp	Manufacturer	Qty
			Angle (L-shaped)	Straight			
SGMG- 03A□B 06A□B 09A□B	CE05-2A18-10PD	MS3106A18-10S (D190)	CE-18BA-S	CE02-18BS-S	CE3057-10A-*	Daiichi Denshi Kogyo K.K.	
12A□B 20A□B 30A□B	JL04HV-2E22-22PE-B	JL04V-6A22-22SE	JL04-22EBL	JL04-22EB	JL04-2022CK (14)	Japan Aviation Electronics Industry, Ltd.	
44A□B 60A□B	JL04V-2E32-17PE-B	JL04V-6A32-17SE	-	-	-	Japan Aviation Electronics Industry, Ltd.	
SGMD- 22A□A 32A□A 40A□A	JL04V-2E24-10PE-B	JL04-6A24-10SE	JL04-24EBL	JL04-24E	JL04-2428CK (17)	Japan Aviation Electronics Industry, Ltd.	

Connector on motor end already provided

To be selected if flexible conduit is used

Not required if flexible conduit is used

To be prepared by customer (cable)

* Select an appropriate model according to the lead wire diameter. Refer to *IP67-based Encoder Connectors on Motor End*.

Enclosure IP67 Main Circuit Connectors on Motor End (with Brake)

(Purchase Separately)

Motor Model	Receptacle	Plug	End Bell: Manufactured by Japan Aviation Electronics Industry, Ltd. Back Shell: Manufactured by Daiichi Denshi Kogyo K.K.		Cable Clamp	Manufacturer	Qty								
			Angle (L-shaped)	Straight											
SGMS- 10A□A 15A□A 20A□A	JL04V-2E20-15PE-B	JL04V-6A20-15SE	JL04-20EBL	JL04-20EB	JL04-2022CK (14)	Japan Aviation Electronics Industry, Ltd.									
								30A□A 40A□A 50A□A	JL04V-2E24-10PE-B	JL04V-6A24-10SE	JL04-24EBL	JL04-24EB	JL04-2428CK (17)	Japan Aviation Electronics Industry, Ltd.	
SGMG- 05A□A 09A□A 13A□A	JL04V-2E20-15PE-B	JL04V-6A20-15SE	JL04-20EBL	JL04-20EB	JL04-2022CK (14)	Japan Aviation Electronics Industry, Ltd.									
								20A□A 30A□A 44A□A	JL04V-2E24-10PE-B	JL04V-6A24-10SE	JL04-24EBL	JL04-24EB	JL04-2428CK (17)	Japan Aviation Electronics Industry, Ltd.	
55A□A 75A□A 1AA□A 1EA□A	JL04V-2E32-17PE-B CE05-2A10S L-3PC	JL04V-6A32-17SE MS3106A10S L-3S(190)*1	- CE-10SLBA-S*	- CE05-10SLBA-S*	- CE3057-4A-1*	Japan Aviation Electronics Industry, Ltd.									

Connector on motor end already provided

To be selected if flexible conduit is used

Not required if flexible conduit is used

To be prepared by customer (cable)

* Connectors for brake power supply

6

Motor Model	Receptacle	Plug	End Bell: Manufactured by Japan Aviation Electronics Industry, Ltd. Back Shell: Manufactured by Daiichi Denshi Kogyo K.K.		Cable Clamp	Manufacturer	Qty
			Angle (L-shaped)	Straight			
SGMG- 03A□B 06A□B 09A□B	JL04V-2E20-15PE-B	JL04V-6A20-15SE	JL04-20EBL	JL04-20EB	JL04-2022CK (14)	Japan Aviation Electronics Industry, Ltd.	
	JL04V-2E24-10PE-B	JL04V-6A24-10SE	JL04-24EBL	JL04-24EB	JL04-2428CK (17)		
	JL04V-2E32-17PE-B	JL04V-6A32-17SE	-	-	-		
60A□B	CE05-2A10S L-3PC	MS3106A10S L-3S(190)*1	CE-10SLBA-S*	CE05-10SLB A-S*	CE3057-4A-1*	Japan Aviation Electronics Industry, Ltd.	
SGMD- 22A□A 32A□A 40A□A	JL04V-2E24-10PE-B	JL04V-6A24-10SE	JL04-24EBL	JL04-24EB	JL04-2428CK (17)	Japan Aviation Electronics Industry, Ltd.	

Connector on motor end already provided

To be selected if flexible conduit is used

Not required if flexible conduit is used

To be prepared by customer (cable)

* Connectors for brake power supply

IP67-based Encoder Connectors on Motor End

(Purchase Separately)

Receptacle	Plug	End Bell: Manufactured by Japan Aviation Electronics Industry, Ltd. Back Shell: Manufactured by Daiichi Denshi Kogyo K.K.		Cable Clamp	Manufacturer	Qty
		Angle (L-shaped)	Straight			
97F3102E20-29 P	MS3106A20-29 S(D190)	CE-20BA-S	CE02-20BS-S	CE3057-12A-1 *	Daiichi Denshi Kogyo K.K.	

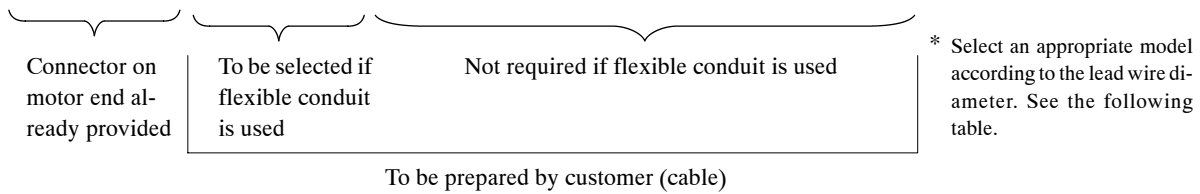

Note: Encoder connectors on the SERVOPACK end (2CN) are the same as the encoder connectors included in the connector kit for the SERVOPACK end (DE9406973).

Cable clamp models classified according to lead wire diameter

Cable Clamp Model	Lead Wire Diameter Range
CE3057-10A-1	φ10.5 to φ14.1
CE3057-10A-2	φØ8.5 to φ11.0
CE3057-10A-3	φ5.5 to φ9.7
CE3057-12A-1	φ12.5 to φ16.0
CE3057-12A-2	φ9.5 to φ13.0
CE3057-12A-3	φ6.8 to φ10.0
JL04-2022CK (14)	φ12.9 to φ15.9
JL04-2428CK (17)	φ15 to φ18

When flexible conduit is used:

Connector Model (Straight)	Conduit Model	Lead Wire Diameter Range
RCC-106RL-MS32F	VF-06 (SR-06)	Max. φ20
RCC-108RL-MS32F	VF-08 (SR-08)	Max. φ26
RCC-110RL-MS32F	VF-10 (SR-10)	Max. φ35
RCC-112RL-MS32F	VF-12 (SR-12)	Max. φ40
RCC-116RL-MS32F	VF-16 (SR-16)	Max. φ51

- Brake Power Supply

Customer must purchase a Brake Power Supply when using a Servomotor with brake.

(Purchase Separately)

Brake Power Supply Model	Qty
LPSE-2H01 (for 200 VAC input)	
LPDE-1H01 (for 100 VAC input)	

- Cables

Cables for Incremental Encoder (Cable with Loose Wire End on Encoder End)

Customer must purchase and attach connectors on encoder end and encoder connectors on servomotor end.

(Purchase Separately)

Cable Model		Qty
JZSP-VEP01-1	3m (9.8 ft)	
JZSP-VEP01-2	5m (16.4 ft)	
JZSP-VEP01-3	10m (32.8 ft)	
JZSP-VEP01-4	15m (49.2 ft)	
JZSP-VEP01-5	20m (65.6 ft)	

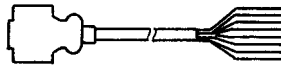

Cables with Straight Plug for Incremental Encoder

(Purchase Separately)

Cable Model		Qty
JZSP-CBP0S-01	3m (9.8 ft)	
JZSP-CBP0S-02	5m (16.4 ft)	
JZSP-CBP0S-03	10m (32.8 ft)	
JZSP-CBP0S-04	15m (49.2 ft)	
JZSP-CBP0S-05	20m (65.6 ft)	

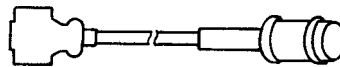

Cables with L-shaped Plug for Incremental Encoder

(Purchase Separately)

Cable Model		Qty
JZSP-CBP0L-01	3m (9.8 ft)	
JZSP-CBP0L-02	5m (16.4 ft)	
JZSP-CBP0L-03	10m (32.8 ft)	
JZSP-CBP0L-04	15m (49.2 ft)	
JZSP-CBP0L-05	20m (65.6 ft)	

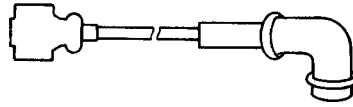

Cables with Loose Wire End on Encoder End for Absolute Encoder

Customer must purchase and attach connectors on encoder end and encoder connectors on servomotor end.

(Purchase Separately)

Cable Model		Qty
JZSP-VEP11-1	3m (9.8 ft)	
JZSP-VEP11-2	5m (16.4 ft)	
JZSP-VEP11-3	10m (32.8 ft)	
JZSP-VEP11-4	15m (49.2 ft)	
JZSP-VEP11-5	20m (65.6 ft)	

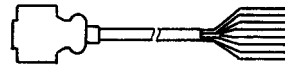

Cables with Straight Plug for Absolute Encoder

(Purchase Separately)

Cable Model		Qty
JZSP-CBP1S-01	3m (9.8 ft)	
JZSP-CBP1S-02	5m (16.4 ft)	
JZSP-CBP1S-03	10m (32.8 ft)	
JZSP-CBP1S-04	15m (49.2 ft)	
JZSP-CBP1S-05	20m (65.6 ft)	

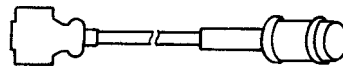

Cables with L-shaped Plug for Absolute Encoder

(Purchase Separately)

Cable Model		Qty
JZSP-CBP1L-01	3m (9.8 ft)	
JZSP-CBP1L-02	5m (16.4 ft)	
JZSP-CBP1L-03	10m (32.8 ft)	
JZSP-CBP1L-04	15m (49.2 ft)	
JZSP-CBP1L-05	20m (65.6 ft)	

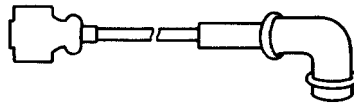

Enclosure IP67-based Encoder Cables

IP67-based encoder cables are not supplied. Customers must purchase an encoder connector kit (2CN) on the SERVOPACK end, an IP67-based encoder connector on the servomotor end, and cable materials, then assemble these items.

- Back-up Battery

(1 provided with SERVOPACK)

Battery Model	Qty
PMC ER6V for use with connector	

- 1CN for I/O Signals
1CN Connector

(Purchase Separately)

Connector Model	Qty
JZSP-VAI09	



1CN

1 x 1CN Connector Only

1CN Connector-Terminal Block Conversion Unit

(Purchase Separately)

Conversion Unit Model	Qty
JUSP-TA36Z	

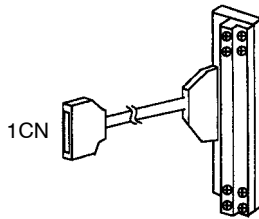

1CN

1CN Connector and Cable (0.5 m)

Cable with 1CN Connector and Loose Wire End

(Purchase Separately)

Cable Model	Qty
JZSP-VBI14-01	1 m (3.3 ft)
JZSP-VBI14-02	2 m (6.6 ft)
JZSP-VBI14-03	3 m (9.8 ft)
JZSP-VBI14-05	5 m (16.4 ft)

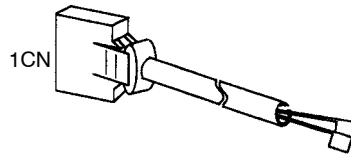

Manual Pulse Generator Cable
(Branch connection, without connector on one end and with 1CN connector on SERVOPACK end.)

(Purchase Separately)

Cable Model		Qty
JZSP-VBX04-01	1 m (3.3 ft)	
JZSP-VBX04-02	2 m (6.6 ft)	
JZSP-VBX04-03	3 m (9.8 ft)	
JZSP-VBX04-05	5 m (16.4 ft)	

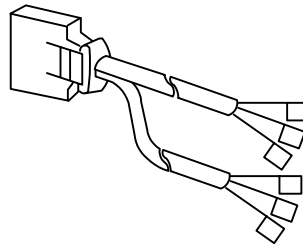

1CN for SERVOPACK

- 3CN for I/O Signals
3CN Connector

(Purchase Separately)

Connector Model	Qty
DE9409459	

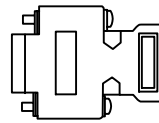

3CN for SERVOPACK

External Position Indicator Cable

(Purchase Separately)

Cable Model		Qty
JZSP-VBX10-01	1 m (3.3 ft)	
JZSP-VBX10-02	2 m (6.6 ft)	
JZSP-VBX10-03	3 m (9.8 ft)	
JZSP-VBX10-05	5 m (16.4 ft)	

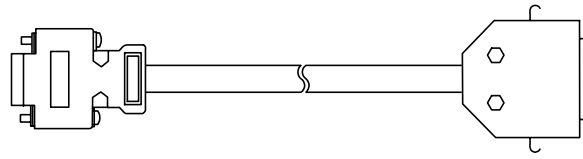

3CN for SERVOPACK

1CN for External Position Indicator

Connector Kit for External Position Indicator

(Purchase Separately)

Connector Kit Model	Qty
JZSP-VBX12	

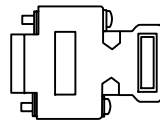

3CN for SERVOPACK

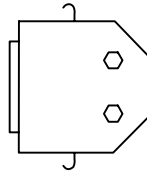

1CN for External Position Indicator

- 6CN for I/O Signals
6CN Connector

(Purchase Separately)

Connector Model	Qty
DE9411289	



6CN

1 x 6CN Connector Only

6CN Connector-Terminal Block Conversion Unit

(Purchase Separately)

Conversion Unit Model	Qty
JUSP-TA50P	

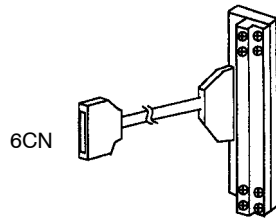

6CN Connector and Cable (0.5 m)

Cable with 6CN Connector and Loose Wire End

(Purchase Separately)

Cable Model		Qty
JZSP-CKI01-1	1 m (3.3 ft)	
JZSP-CKI01-2	2 m (6.6 ft)	
JZSP-CKI01-3	3 m (9.8 ft)	

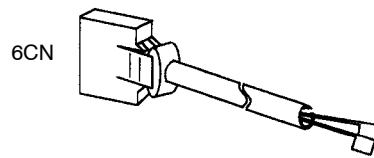

Digital Switch Unit or Contact Input Unit Cable

(Branch connection, without connector on one end and with connector on Digital Switch Unit or Contact Input Unit end, and 6CN connector on SERVOPACK end.)

(Purchase Separately)

Cable Model		Qty
JZSP-VBX24-01	1 m (3.3 ft)	
JZSP-VBX24-02	2 m (6.6 ft)	
JZSP-VBX24-03	3 m (9.8 ft)	
JZSP-VBX24-05	5 m (16.4 ft)	

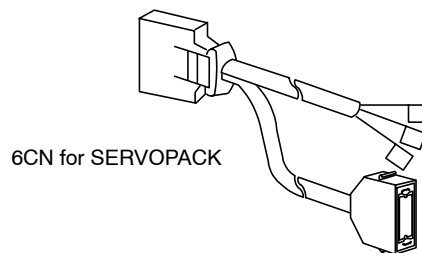

1CN for Digital Switch Unit or 3CN for Contact Input Unit

Connector Kit for Digital Switch Unit

(Purchase Separately)

Connector Kit Model	Qty
JZSP-VBX22	



6CN for SERVOPACK

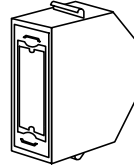

1CN for Digital Switch Unit

For SGM and SGMP Servomotors (Excluding SGMP-15A)

Cable for Servomotor without Brake, with Connector and Amplifier Terminal

(Purchase Separately)

Cable Model	Qty
DP9320081-1	3 m (9.8 ft)
DP9320081-2	5 m (16.4 ft)
DP9320081-3	10 m (32.8 ft)
DP9320081-4	15 m (49.2 ft)
DP9320081-5	20 m (65.6 ft)

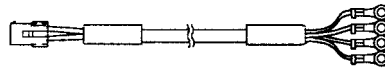

Cables for Servomotor without Brake, Cable Material Only

Customer must purchase and attach the connector and amplifier terminal.

(Purchase Separately)

Cable Model	Qty
DP8409359-1	3 m (9.8 ft)
DP8409359-2	5 m (16.4 ft)
DP8409359-3	10 m (32.8 ft)
DP8409359-4	15 m (49.2 ft)
DP8409359-5	20 m (65.6 ft)



Cables for Servomotor with Brake, with Connector and Amplifier Terminal

(Purchase Separately)

Cable Model		Qty
DP9320083-1	3 m (9.8 ft)	
DP9320083-2	5 m (16.4 ft)	
DP9320083-3	10 m (32.8 ft)	
DP9320083-4	15 m (49.2 ft)	
DP9320083-5	20 m (65.6 ft)	

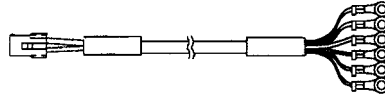

Cables for Servomotor with Brake, Cable Material Only

Customer must purchase and attach the connector and amplifier terminal.

(Purchase Separately)

Cable Model		Qty
DP8409360-1	3 m (9.8 ft)	
DP8409360-2	5 m (16.4 ft)	
DP8409360-3	10 m (32.8 ft)	
DP8409360-4	15 m (49.2 ft)	
DP8409360-5	20 m (65.6 ft)	

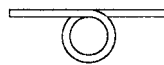

Connector Kit

(Purchase Separately)

Connector Kit Model	Qty
DP9420006-1 (for incremental encoder, without brake)	
DP9420006-2 (for incremental encoder, with brake)	
DP9420006-3 (for absolute encoder, without brake)	
DP9420006-4 (for absolute encoder, with brake)	

- The following three items are supplied as a set.

1. Motor connector on motor end: Connector for motor with or without brake × 1

2. Encoder connector on motor end: Connector for incremental or absolute encoder × 1
3. Encoder connector on SERVOPACK end: 2CN connector × 1

Connectors for SGMG, SGMS, and SGMD Servomotors are provided separately. Refer to 6.6.3 *Connector* for models and other information.

Motor Connector on Motor End

Encoder Connector on Motor End

Encoder Connector on SERVOPACK End

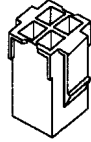

Without Brake

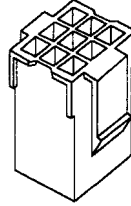

For Incremental Encoder

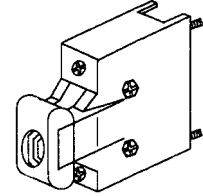

For SGMP-15A Servomotors

- Servomotor Cables

Cables for Servomotor without Brake, with Connector and Amplifier Terminal

(Purchase Separately)

Cable Model		Qty
DP9320827-1	3 m (9.8 ft)	
DP9320827-2	5 m (16.4 ft)	
DP9320827-3	10 m (32.8 ft)	
DP9320827-4	15 m (49.2 ft)	
DP9320827-5	20 m (65.6 ft)	

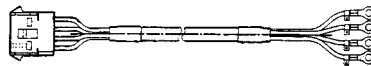

Cables for Servomotor without Brake, Cable Material Only

Customer must purchase and attach the connector and amplifier terminal.

(Purchase Separately)

Cable Model		Qty
DP9402221-1	3 m (9.8 ft)	
DP9402221-2	5 m (16.4 ft)	
DP9402221-3	10 m (32.8 ft)	
DP9402221-4	15 m (49.2 ft)	
DP9402221-5	20 m (65.6 ft)	



Cables for Servomotor with Brake, with Connector and Amplifier Terminal

(Purchase Separately)

Cable Model		Qty
DP9320828-1	3 m (9.8 ft)	
DP9320828-2	5 m (16.4 ft)	
DP9320828-3	10 m (32.8 ft)	
DP9320828-4	15 m (49.2 ft)	
DP9320828-5	20 m (65.6 ft)	

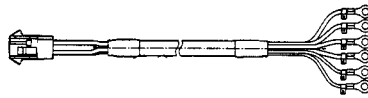

Cables for Servomotor with Brake, Cable Material Only

Customer must purchase and attach the connector and amplifier terminals.

(Purchase Separately)

Cable Model		Qty
DP9402222-1	3 m (9.8 ft)	
DP9402222-2	5 m (16.4 ft)	
DP9402222-3	10 m (32.8 ft)	
DP9402222-4	15 m (49.2 ft)	
DP9402222-5	20 m (65.6 ft)	

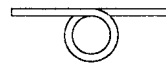

- Connectors

For SGMP-15A Servomotors, purchase one of the following connectors.

(Purchase Separately)

Connector Kit Model	Qty
DP9420016-1 (for incremental encoder, no brake)	
DP9420016-2 (for incremental encoder, with brake)	
DP9420016-3 (for absolute encoder, no brake)	
DP9420016-4 (for absolute encoder, with brake)	

- The following three items are supplied as a set.

- Main circuit connector on motor end: Connector for motor with or without brake × 1

- Encoder connector on motor end: Connector for incremental or absolute encoder × 1
- Encoder connector on SERVOPACK end: Connector 2CN × 1

Connectors for SGMG, SGMS, and SGMD Servomotors are provided separately. Refer to 6.6.3 *Connector* for models and other information.

Main Circuit Connector on Motor End

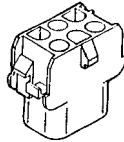

With Brake

Encoder Connector on Motor End

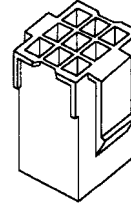

For Incremental Encoder

Encoder Connector on SERVOPACK End

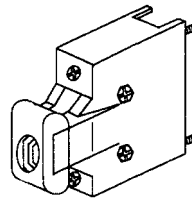

For SGM and SGMP Servomotors

- Brake Power Supply

The customer must purchase a brake power supply when using a servomotor with brake.

(Purchase Separately)

Brake Power Supply Model	Qty
LPSE-2H01 (for 200 VAC input)	
LPDE-1H01 (for 100 VAC input)	

- Encoder Cables

Cables for Incremental Encoder, with Connector on Both Ends

(Purchase Separately)

Cable Model	Qty
JZSP-CAP00-01	3m (9.8 ft)
JZSP-CAP00-02	5m (16.4 ft)
JZSP-CAP00-03	10m (32.8 ft)
JZSP-CAP00-04	15m (49.2 ft)
JZSP-CAP00-05	20m (65.6 ft)

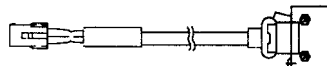

Cables for Incremental Encoder, SERVOPACK End without Connectors

Customer must purchase and attach connector on SERVOPACK end and connector kit.

(Purchase Separately)

Cable Model		Qty
DP9320086-1	3m (9.8 ft)	
DP9320086-2	5m (16.4 ft)	
DP9320086-3	10m (32.8 ft)	
DP9320086-4	15m (49.2 ft)	
DP9320086-5	20m (65.6 ft)	

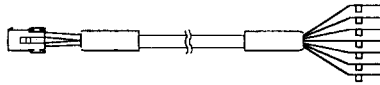

Cables for Incremental Encoder, Cable Only

Customer must purchase and attach connectors on both ends of cable and connector kit.

(Purchase Separately)

Cable Model		Qty
B9400064-1	3m (9.8 ft)	
B9400064-2	5m (16.4 ft)	
B9400064-3	10m (32.8 ft)	
B9400064-4	15m (49.2 ft)	
B9400064-5	20m (65.6 ft)	



Cables for Absolute Encoder, Connectors on Both Ends

(Purchase Separately)

Cable Model		Qty
JZSP-CAP10-01	3m (9.8 ft)	
JZSP-CAP10-02	5m (16.4 ft)	
JZSP-CAP10-03	10m (32.8 ft)	
JZSP-CAP10-04	15m (49.2 ft)	
JZSP-CAP10-05	20m (65.6 ft)	

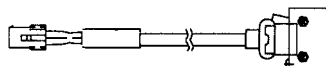

Cables for Absolute Encoder, SERVOPACK End without Connectors

Customer must purchase and attach connector on SERVOPACK end and connector kit.

(Purchase Separately)

Cable Model		Qty
DP9320085-1	3m (9.8 ft)	
DP9320085-2	5m (16.4 ft)	
DP9320085-3	10m (32.8 ft)	
DP9320085-4	15m (49.2 ft)	
DP9320085-5	20m (65.6 ft)	



Cables for Absolute Encoder, Cable Only

Customer must purchase and attach connectors on both ends of cable and connector kit.

(Purchase Separately)

Cable Model		Qty
DP8409123-1	3m (9.8 ft)	
DP8409123-2	5m (16.4 ft)	
DP8409123-3	10m (32.8 ft)	
DP8409123-4	15m (49.2 ft)	
DP8409123-5	20m (65.6 ft)	



Other Peripheral Devices

Order lists are given below for noise filters, magnetic contactors, surge suppressors, regenerative resistor units, and personal computer connecting cables.

- Noise Filter

(Purchase Separately)

Noise Filter Model	Qty
LF-310 (10A)	
LF-315 (15A)	
LF-320 (20A)	
LF-330 (30A)	

Noise Filter Model	Qty
LF-340 (40A)	
LF-350 (50A)	
LF-360 (60A)	
LF-380K (80A)	
FN258-100/35 (100A)	

- Magnetic Contactor

(Purchase Separately)

Magnetic Contactor Model	Qty
HI-15J (35A)	
HI-18J (35A)	
HI-20J (35A)	
HI-25J (50A)	
HI-35J (65A)	
HI-50J (75A)	
HI-65J (100A)	

- Surge Suppressor

(Purchase Separately)

Surge Suppressor Model	Qty
TU-25C240	
TU-65C240	

- Regenerative Resistor Unit

(Purchase Separately)

Regenerative Resistor Unit Model	Qty
JUSP-RA04	
JUSP-RA05	

- Personal Computer Connecting Cables

(Purchase Separately)

Cable Model	Qty
DE9408565 (for PC/AT-compatible computers)	2m (6.6 ft)

6.6 Specifications and Dimensional Drawings of Peripheral Devices

This section shows the specifications and dimensional drawings of the peripheral devices required for the Σ -Series servo system. The sequence of peripheral devices is given by the Flowchart for Peripheral Device Selection in *6.5.1 Selecting Peripheral Devices*.

6.6.1 Cable Specifications and Peripheral Devices

The cable sizes and peripheral devices for SGDB SERVOPACKs are listed in the following tables.

IMPORTANT

Wiring Precautions

Do not pass the power lines and signal lines through the same duct, or bundle them together. Power lines and signal lines should be laid at least 30 cm apart.

Use twisted-pair cables and multi-core shielded twisted-pair cables for signal lines and encoder (PG) feedback lines. Command input lines should be no more than 5 m, and PG feedback lines should be no more than 20 m in length.

■ **Cable Sizes**

The following table shows the cable size specifications.

Table 6.16 SERVOPACK Cable Sizes

External Terminal Name		SGDB- Terminal Symbol	Example Cable Size (mm ²)									
			02AM	05AM	10AM	15 AM	20 AM	30AM	50AM	60AM	75AM	1A AM
Online Terminal	Main Circuit Power Input Terminal	L1, L2, L3	HIV 1.25 or more	HIV 2.0 or more	HIV 3.5 or more	HIV 3.5 or more	HIV 5.5 or more	HIV 8 or more	HIV 14 or more	HIV 22 or more		
	Motor Connection Terminal	U, V, W	HIV 1.25 or more	HIV 3.5 or more	HIV 5.5 or more	HIV 8 or more	HIV 14 or more	HIV 22 or more				
	Control Power Input Terminal	L1C, L3C	HIV 1.25 or more									

External Terminal Name		SGDB- Terminal Symbol	Example Cable Size (mm ²)									
			02AM	05AM	10AM	15 AM	20 AM	30AM	50AM	60AM	75AM	1A AM
Offline Terminal	Control I/O Signal Connector	1CN, 6CN	Shielded twisted-pair or twisted-pair cables Tinned annealed copper twisted cable with core 0.12 mm ² or greater. Outside dimensions of finished cable: max. φ16 (for 1CN and 6CN); max. φ11 (for 2CN)									
	PG Signal Connector	2CN										
	Ground Terminal		HIV 2.0 or more									

- Note: 1. Cable size selection conditions: Ambient temperature 40°C, 3 cables per bundle, and rated current flowing
 2. For the main circuit, use cables with a dielectric strength of 600 V or more.
 3. Consider allowable current reduction ratio if cables are bundled in rigid PVC tube or metal ducts.

The types of cable are shown in the table below. Use it in combination with the tables.

Cable Type		Conductor Allowable Temperature °C
Symbol	Name	
PVC	Normal vinyl cable	–
IV	600 V vinyl cable	60
HIV	Temperature-resistant vinyl cable	75

- Note: 1. For the main circuit, use cables with a dielectric strength of 600 V or higher.
 2. Consider allowable current reduction ratio if cables are bundled in rigid PVC tube or metal ducts.
 3. Use temperature-resistant cable under high ambient or panel temperature where normal vinyl cables rapidly deteriorate.

■ Models and Capacities of Peripheral Devices

The models and capacities of peripheral devices compatible with SERVOPACK are shown in the following table.

Table 6.17 Models and Capacities of Peripheral Devices

SERVOPACK Model SGDB-	Motor Model	Motor Selection (Cn-2A)	MCCB or Fuse Capacity*1	Main Power Inrush Current (peak value)	Recommended Line Filter*2	Power ON/OFF Switch
02AM	SGM-02A	104	5A	28A	LF310(10A)	HI-15J(35A)
	SGMP-02A	124				
05AM	SGMG-03A□B	171	5A	28A	LF310(10A)	
	SGM-04A	106				
	SGMP-04A	126				
	SGMG-05A□A	142				
10AM	SGMG-06A□B	172	8A		LF315(15A)	
	SGM-08A	107				
	SGMP-08A	127				
	SGMG-09A□A	143				
	SGMG-09A□B	173				
	SGMG-10A□A	163				
15AM	SGMG-12A□B	174	10A			
	SGMG-13A□A	144				
	SGMP-15A	128				
	SGMS-15A□A	164				

* 1. Braking characteristics (at 25°C): 200% for 2 s or longer, 700% for 0.01 s or longer.

* 2. Yaskawa recommends noise filters manufactured by Tokin Corp and by Shaffner. Yaskawa Controls Co., Ltd. can supply these noise filters.

SERVOPACK Model SGDB-	Motor Model	Motor Selection (Cn-2A)	MCCB or Fuse Capacity*1	Main Power Inrush Current (peak value)	Recommended Line Filter*2	Power ON/OFF Switch
20AM	SGMG-20A□A	145	12A	56A	LF320(20A)	HI-18J(35A)
	SGMG-20A□B	175				
	SGMS-20A□A	165				
30AM	SGMD-22A□A	155	18A	56A	LF330(30A)	HI-18J(35A)
	SGMG-30A□A	146				
	SGMG-30A□B	176				
	SGMG-30A□A	166				
50AM	SGMD-32A□A	156	28A	58A	LF340(40A)	HI-18J(35A)
	SGMG-44A□A	147				
	SGMG-44A□B	177				
	SGMS-40A□A	167				
	SGMD-40A□A	157				
	SGMS-50A□A	168				
60AM	SGMG-55A□A	148	32A	93A	LF350(50A)	HI-25J(50A)
	SGMG-60A□B	178				
75AM	SGMG-75A□A	149	41A		LF360(60A)	HI-35J(65A)
1AAM	SGMG-1AA□A	140	60A	116A	LF380K(80A)	HI-50J(75A)
1EAM	SGMG-1EA□A	150	80A		FN258-100/35 (100A) (made by Schaffner)	HI-65J(100A)

* 1. Braking characteristics (at 25°C): 200% for 2 s or longer, 700% for 0.01 s or longer

* 2. Yaskawa recommends noise filters manufactured by Tokin Corp and by Shaffner. Yaskawa Controls Co., Ltd. can supply these noise filters.

The appropriate cables for SERVOPACK connectors 1CN, 2CN, 3CN, and 6 CN are shown in the table below.

Cable selection conditions: three cables per bundle at an ambient temperature of 40°C, with the rated current flowing.

Table 6.18 Cables for Connectors 1CN and 2CN

Control I/O Signal Connector	1CN and 6CN	Cable	Use twisted-pair cable or shielded twisted-pair cable.
		Applicable Wire Size	AWG24, 26, 28, 30
		Finished Cable Dimensions	Ø16.0 mm (Ø 0.63 in.) MAX.
Serial Communications Connector	3CN	Cable	Use shielded twisted-pair cable.
		Applicable Wire Size	AWG24, 26, 28, 30
		Finished Cable Dimensions	φ7.0 mm (φ0.28 in.) MAX.
PG Signal Connector	2CN	Cable	Use Yaskawa cable. Use shielded twisted-pair cable if Yaskawa cable is not used.
		Applicable Wire Size	Applicable wire sizes: AWG24, 26, 28, 30. However, use AWG22 (0.32 mm ²) for encoder power supply and FG line. Use AWG26 (0.12 mm ²) for other signal lines. These connections permit wiring distances up to 20 m (65.6 ft).
		Finished Cable Dimensions	Ø11.6 mm (Ø0.46 in.) MAX.

6.6.2 Motor Cables

Select an appropriate motor cable that meets the customer’s service conditions by referring to the cable specifications described in *6.6.1 Cable Specifications and Peripheral Devices*.

6.6.3 Connector

Each connector consists of a plug, cable clamp, and back shell. The connectors to be used differ according to the servomotor used.

This section describes connectors separately for the SGMG/SGMS/SGMD models, SGM/SGMP models (excluding SGMP-15A), and SGMP-15A model.

■ For the SGMG, SGMS, SGMD Models

Connectors are divided into the three types shown in the figure: one encoder connector at both the motor and SERVOPACK ends of the cable and a motor connector at the motor end of the cable. These connectors are common to both encoder types (incremental and absolute encoders).

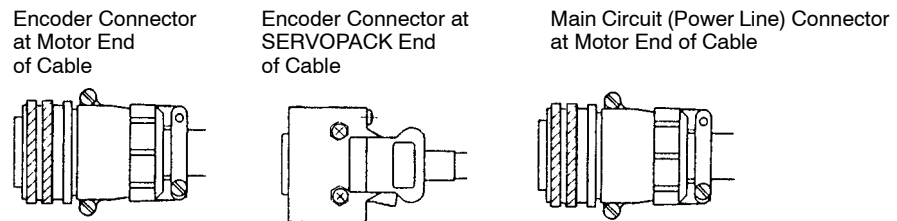

To connect the motor at the SERVOPACK end of the cable, use the crimp terminals (to be prepared by the customer).

The connector model to be used differs according to the following items:

- Straight plug or L-shaped plug
- Motor with or without brake
- Model and capacity of the servomotor
- Operating environment

Always order the connectors under the following conditions:

- Connectors for all cables (required regardless of whether the motor has brake or not)
- Connectors for encoder cables with a connector only on the SERVOPACK end of the cable or for encoder cables without connector (required regardless of the encoder model (incremental or absolute))
- Connectors for encoders (on the motor and SERVOPACK ends of the cable) when IP 67 specifications are used

Encoder Cable Connectors

Encoder cable connectors are divided into the six models shown in the following table according to the operating environment and the plug shape.

Table 6.19 Models of Encoder Cable Connector

Operating Environment		Parts	Straight Model	L-shaped (Angle) Model	Manufacturer
Standard Environment	-	Plug	MS3106B20-29S	MS3108B20-29S	Daiichi Denshi Kogyo K.K.
		Cable Clamp	MS3057-12A-*		
IP67-based Environment	Flexible Conduit Used	Plug Only	MS3106A20-29S (D190)	-	
	Flexible Conduit Not Used	Plug Only	MS3106A20-29S(D190)		
		Back Shell	CE02-20BS-S	CE-20BA-S	
		Cable Clamp	CE3057-12A-*		

* Select an appropriate model according to the lead wire diameter.

● Examples of Connector Combination

The following examples show how to combine connectors manufactured by Daiichi Denshi Kogyo K.K.

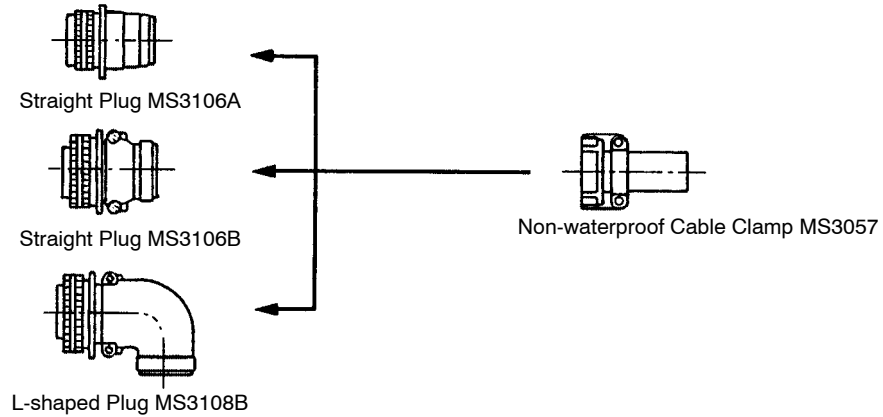

Figure 6.6 For Standard Environment

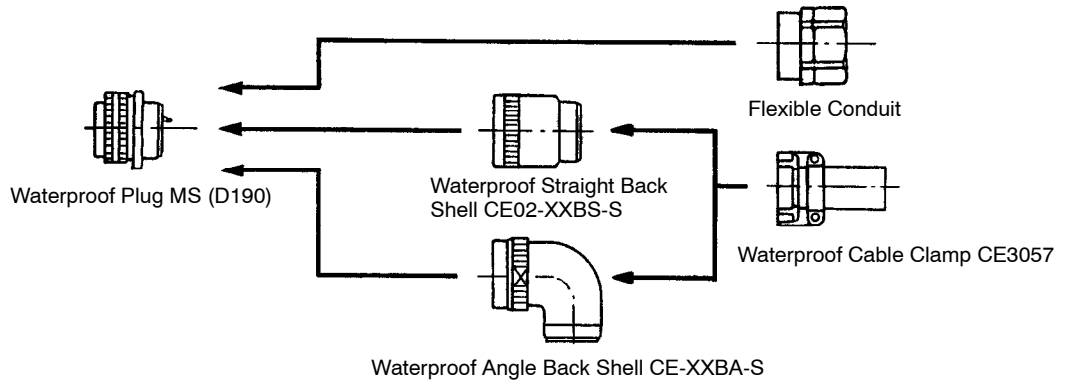

Figure 6.7 For IP67-based Environment

Servomotor Cable Connectors

Servomotor cable connectors are grouped according to the environment in which the motor is used, the presence or absence of a brake, and the model and capacity of the motor.

The crimp terminal on the SERVOPACK side should be supplied by the customer.

- Standard Environment

The following table shows the connectors for standard servomotors without brake.

Table 6.20 Connectors for Standard Servomotors without Brake

Motor Model	Connectors on Motor End			
	Receptacle	L-shaped Plug	Straight Plug	Cable Clamp
SGMS- 10A□A 15A□A 20A□A	MS3102A18-10P	MS3108B18-10S	MS3106B18-10S	MS3057-10A
	MS3102A22-22P	MS3108B22-22S	MS3106B22-22S	MS3057-12A
	MS3102A32-17P	MS3108B32-17S	MS3106B32-17S	MS3057-20A
SGMG- 05A□A 09A□A 13A□A	MS3102A18-10P	MS3108B18-10S	MS3106B18-10S	MS3057-10A
	MS3102A22-22P	MS3108B22-22S	MS3106B22-22S	MS3057-12A
	MS3102A32-17P	MS3108B32-17S	MS3106B32-17S	MS3057-20A
SGMG- 20A□A 30A□A 44A□A	MS3102A18-10P	MS3108B18-10S	MS3106B18-10S	MS3057-10A
	MS3102A22-22P	MS3108B22-22S	MS3106B22-22S	MS3057-12A
	MS3102A32-17P	MS3108B32-17S	MS3106B32-17S	MS3057-20A
	MS3102A32-17P	MS3108B32-17S	MS3106B32-17S	MS3057-20A
SGMG- 55A□A 75A□A 1AA□A 1EA□A	MS3102A18-10P	MS3108B18-10S	MS3106B18-10S	MS3057-10A
	MS3102A22-22P	MS3108B22-22S	MS3106B22-22S	MS3057-12A
	MS3102A32-17P	MS3108B32-17S	MS3106B32-17S	MS3057-20A

Connector on motor side already provided

To be prepared by customer (cable)

6.6.3 Connector

Motor Model	Connectors on Motor End			
	Receptacle	L-shaped Plug	Straight Plug	Cable Clamp
SGMG- 03A□B 06A□B 09A□B	MS3102A18-10P	MS3108B18-10S	MS3106B18-10S	MS3057-10A
12A□B 20A□B 30A□B	MS3102A22-22P	MS3108B22-22S	MS3106B22-22S	MS3057-12A
44A□B 60A□B	MS3102A32-17P	MS3108B32-17S	MS3106B32-17S	MS3057-20A
SGMD- 22A□A 32A□A 40A□A	MS3102A24-10P	MS3108B24-10S	MS3106B24-10S	MS3057-16A

Connector on motor side already provided

To be prepared by customer (cable)

MS3106B Straight Plug Shell

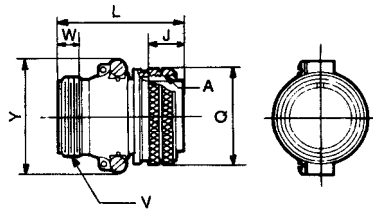

Unit: mm (in)

Shell Size	Joint Screw A	Length of Joint Portion $J \pm 0.12$ (± 0.0047)	Overall Length L or less	Outside Diameter of Joint Nut $\varnothing Q \begin{smallmatrix} +0 \\ -0.38 \\ (-0.0150) \end{smallmatrix}$	Cable Clamp Set Screw	Effective Screw Length W or more	Maximum Width Y or less
18	11/8-18UNEF	18.26 (0.72)	52.37 (2.06)	34.13 (1.34)	1-20UNEF	9.53 (0.38)	42 (1.65)
20	11/4-18UNEF	18.26 (0.72)	55.57 (2.19)	37.28 (1.47)	13/16-18UNEF	9.53 (0.38)	47 (1.85)
22	13/8-18UNEF	18.26 (0.72)	55.57 (2.19)	40.48 (1.59)	13/16-18UNEF	9.53 (0.38)	50 (1.97)
24	11/2-18UNEF	18.26 (0.72)	58.72 (2.31)	43.63 (1.72)	17/16-18UNEF	9.53 (0.38)	53 (2.09)
32	2-18UNS	18.26 (0.72)	61.92 (2.44)	56.33 (2.28)	13/4-18UNS	11.13 (0.44)	66 (2.60)

MS3108B L-Plug Shell

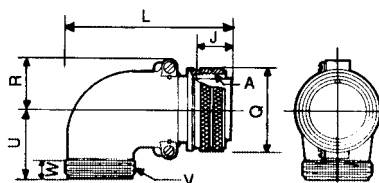

Unit: mm (in)

Shell Size	Joint Screw A	Length of Joint Portion $J \pm 0.12$ (± 0.0047)	Overall Length L or less	Outside Diameter of Joint Nut $\varnothing Q \begin{smallmatrix} +0 \\ -0.38 \\ (-0.0150) \end{smallmatrix}$	$R \pm 0.5$ (0.02)	$U \pm 0.5$ (0.02)	Cable Clamp Set Screw V	Effective Screw Length W or more
10SL								
18	11/8-18UNEF	18.26 (0.72)	68.27 (2.69)	34.13 (1.34)	20.5 (0.81)	30.2 (1.19)	1-20UNEF	9.53 (0.38)
20	11/4-18UNEF	18.26 (0.72)	76.98 (3.03)	37.28 (1.45)	22.5 (0.89)	33.3 (1.31)	13/16-18UNEF	9.53 (0.38)
22	13/8-18UNEF	18.26 (0.72)	76.98 (3.03)	40.48 (1.59)	24.1 (0.95)	33.3 (1.31)	13/16-18UNEF	9.53 (0.38)
24	11/2-18UNEF	18.26 (0.72)	86.51 (3.41)	43.63 (1.72)	25.6 (1.01)	36.5 (1.44)	17/16-18UNEF	9.53 (0.38)
32	2-18UNS	18.26 (0.72)	95.25 (3.75)	56.33 (2.22)	32.8 (1.29)	44.4 (1.75)	13/4-18UNS	11.13 (0.44)

MS3106A Straight Plug Shell

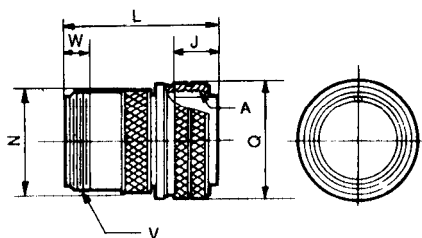

Unit: mm (in)

Shell Size	Joint Screw A	Length of Joint Portion $J \pm 0.12$ (± 0.0047)	Overall Length $L \pm 1.5$ (± 0.00591)	Outside Diameter of Joint Nut $\varnothing Q \begin{smallmatrix} +0 \\ -0.38 \\ (-0.0150) \end{smallmatrix}$	$\varnothing N \pm 0.5$ (± 0.0197)	Cable Clamp Set Screw V	Effective Screw Length W or more
10SL	5/8-24UNEF	13.49 (0.53)	34.9 (1.37)	22.22 (0.87)	19.12 (0.75)	5/8-24UNEF	9.53(0.38)

MS3057-XXA Cable Clamp (with Rubber Bushing)

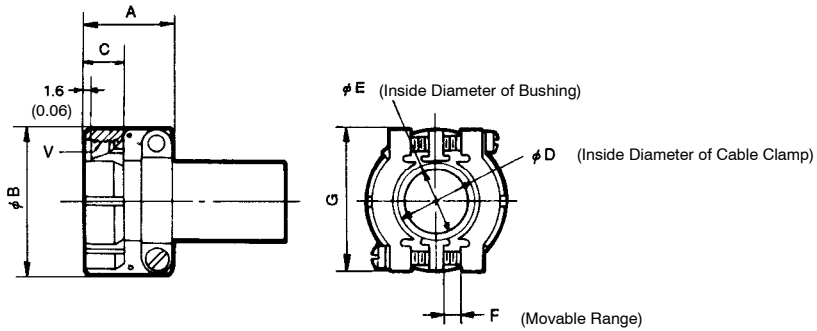

Unit: mm (in)

Part Number	Shell Size of Connector	Overall Length $A \pm 0.7$ (± 0.0276)	Outside Diameter $\phi B \pm 0.7$ (± 0.0276)	Cable Clamp C	ϕD	ϕE	F	$G \pm 0.7$ (± 0.03)	Set Screw V	Attached Bushing
MS3057-4A	10SL, 12S	20.6 (0.81)	20.6 (0.81)	10.3 (0.41)	7.9 (0.31)	5.6 (0.22)	1.6 (0.06)	22.2 (0.87)	5/8-24UNEF	AN3420-4
MS3057-10A	18	23.8 (0.94)	30.1 (1.19)	10.3 (0.41)	15.9 (0.63)	14.3 (0.56)	3.2 (0.13)	31.7 (1.25)	1-20UNEF	AN3420-10
MS3057-12A	20, 22	23.8 (0.94)	35.0 (1.38)	10.3 (0.41)	19.0 (0.75)	15.9 (0.63)	4.0 (0.16)	37.3 (1.49)	13/16-18UNEF	AN3420-12
MS3057-16A	24, 28	26.2 (1.03)	42.1 (1.66)	10.3 (0.41)	23.8 (0.94)	15.9 (0.63) 19.1 (0.75)	4.8 (0.19)	42.9 (1.69)	17/16-18UNEF	AN3420-12 AN3420-16
MS3057-20A	32	27.8 (1.09)	51.6 (2.03)	11.9 (0.47)	31.7 (1.25)	19.1 (0.75) 23.8 (0.94)	6.3 (0.25)	51.6 (2.03)	13/4-18UNS	AN3420-16 AN3420-20

6

The following table shows the connectors for standard servomotors with brake.

Table 6.21 Connectors for Standard Servomotors with Brakes

Motor Model	Connectors on Motor Side			
	Receptacle	L-shaped Plug	Straight Plug	Cable Clamp
SGMS- 10A□A 15A□A 20A□A 30A□A 40A□A 50A□A	MS3102A20-15P	MS3108B20-15S	MS3106B20-15S	MS3057-12A
	MS3102A24-10P	MS3108B24-10S	MS3106B24-10S	MS3057-16A
SGMG- 05A□A 09A□A 13A□A 20A□A 30A□A 44A□A 55A□A 75A□A 1AA□A 1EA□A	MS3102A20-15P	MS3108B20-15S	MS3106B20-15S	MS3057-12A
	MS3102A24-10P	MS3108B24-10S	MS3106B24-10S	MS3057-16A
SGMG- 03A□B 06A□B 09A□B 12A□B 20A□B 30A□B 44A□B 60A□B	MS3102A20-15P	MS3108B20-15S	MS3106B20-15S	MS3057-12A
	MS3102A24-10P	MS3108B24-10S	MS3106B24-10S	MS3057-16A
SGMD- 22A□A 32A□A 40A□A	MS3102A32-17P MS3102A10SL-3P	MS3108B32-17S MS3108B10SL-3S	MS3106B32-17S MS3106A10SL-3S	MS3057-20A MS3057-4A
	MS3102A24-10P	MS3108B24-10S	MS3106B24-10S	MS3057-16A

Connector on motor
side already provided

To be prepared by customer (cable)

Note: In the cells containing two rows, the upper row connector model is for the motor and the lower row connector model is for the brake.

- IP67-based Environment

The following table shows the connectors for IP67-based servomotors without brake.

Table 6.22 Connectors for IP67-based Servomotors without Brakes

	Motor Model	Receptacle	Plug	End Bell: Manufactured by Japan Aviation Electronics Industry, Ltd. Back Shell: Manufactured by Daiichi Denshi Kogyo K.K.		Cable Clamp	Manufacturer							
				Angle (L-shaped)	Straight									
M o t o r s	SGMS- 10A□A 15A□A 20A□A	CE05-2A18-1 0PD	MS3106A18-1 0S(D190)	CE-18BA-S	CE02-18BS-S	CE3057-10A-*	Daiichi Denshi Kogyo K.K.							
								30A□A 40A□A 50A□A	JL04HV-2E22 -22PE-B	JL04V-6A22-2 2SE	JL04-22EBL	JL04-22EB	JL04-2022CK (14)	Japan Aviation Electronics In- dustry, Ltd.
	SGMG- 05A□A 09A□A 13A□A	CE05-2A18-1 0PD	MS3106A18-1 0S(D190)	CE-18BA-S	CE02-18BS-S	CE3057-10A-*	Daiichi Denshi Kogyo K.K.							
								20A□A 30A□A 44A□A	JL04HV-2E22 -22PE-B	JL04V-6A22-2 2SE	JL04-22EBL	JL04-22EB	JL04-2022CK (14)	Japan Aviation Electronics In- dustry, Ltd.
	55A□A 75A□A 1AA□A 1EA□A	JL04V-2E32- 17PE-B	JL04V-6A32-1 7SE	*1	*1	*1	Japan Aviation Electronics In- dustry, Ltd.							
								SGMG- 03A□B 06A□B 09A□B	CE05-2A18-1 0PD	MS3106A18-1 0S(D190)	CE-18BA-S	CE02-18BS-S	CE3057-10A-*	Daiichi Denshi Kogyo K.K.
	12A□B 20A□B 30A□B	JL04HV-2E22 -22PE-B	JL04V-6A22-2 2SE	JL04-22EBL	JL04-22EB	JL04-2022CK (14)	Japan Aviation Electronics In- dustry, Ltd.							
	SGMD- 22A□A 32A□A 40A□A	JL04V-2E24- 10PE-B	JL04-6A24- 10SE	JL04-24EBL	JL04-24EB	JL04-2428CK (17)	Japan Aviation Electronics In- dustry, Ltd.							

Connector on motor side already provided

To be prepared by customer (cable)

* 1. The SGMG-55A□A, -75A□A, -1AA□A, -1EA□A, -44A□B, and -60A□B motors do not contain End Bell (manufactured by Japan Aviation Electronics Industry, Ltd.). For these motors, use flexible conduit instead.

- Note: 1. To ensure compliance with IP67, always use correct combinations of receptacles and plugs.
2. Select an appropriate cable clamp model (mark *) according to the lead wire diameter.
 3. When flexible conduit is used, select plug only.

The following table shows the connectors for IP67-based servomotors with brake.

Table 6.23 Connectors for IP67-based Servomotors with Brakes

	Motor Model	Receptacle	Plug	End Bell: Manufactured by Japan Aviation Electronics Industry, Ltd. Back Shell: Manufactured by Daiichi Denshi Kogyo K.K.		Cable Clamp	Manufacturer	
				Angle (L-shaped)	Straight			
M o t o r s	SGMS- 10A□A 15A□A 20A□A	JL04V-2E20-1 5PE-B	JL04V-6A20-1 5SE	JL04-20EBL	JL04-20EB	JL04-2022CK (14)	Japan Aviation Electronics In- dustry, Ltd.	
				JL04-24EBL	JL04-24EB			JL04-2428CK (17)
	SGMG- 05A□A 09A□A 13A□A	JL04-2E20-15 PE-B	JL04V-6A20-1 5SE	JL04-20EBL	JL04-20EB	JL04-2022CK (14)	Japan Aviation Electronics In- dustry, Ltd.	
				JL04-24EBL	JL04-24EB			JL04-2428CK (17)
	55A□A 75A□A 1AA□A 1EA□A	JL04V-2E32-1 7PE-B CE05-2A10SL -3PC	JL04V-6A32-1 7SE MS3106A10S L-3S(D190)*1	*2	*2	*2	Japan Aviation Electronics In- dustry, Ltd. Daiichi Denshi Kogyo K.K.	
				CE-10SLBA-S *1	CE-10SLBS-S *1			CE3057-4A-1 *1
	SGMG- 03A□B 06A□B 09A□B	JL04V-2E20-1 5PE-B	JL04V-6A20-1 5SE	JL04-20EB	JL04-20EB	JL04-2022CK (14)	Japan Aviation Electronics In- dustry, Ltd.	
				JL04-24EBL	JL04-24EB			JL04-2428CK (17)
				*2	*2			*2
	12A□B 20A□B 30A□B	JL04V-2E24-1 0PE-B	JL04V-6A24-1 0SE	JL04-24EBL	JL04-24EB	JL04-2428CK (17)	Japan Aviation Electronics In- dustry, Ltd.	
				*2	*2			*2
	44A□B 60A□B	JL04V-2E32-1 7PE-B CE05-2A10SL -3PC	JL04V-6A32-1 7SE MS3106A10S L-3S(D190)*1	CE-10SLBA-S *1	CE05-10SLBS-S *1	CE3057-4A-1 *1	Japan Aviation Electronics In- dustry, Ltd. Daiichi Denshi Kogyo K.K.	

Connector on motor side already provided

To be prepared by customer (cable)

* 1. Holding brakes are applicable to both L-shaped and straight types (manufactured by Daiichi Denshi Kogyo K.K.).

* 2. The SGMG-55A□A, -75A□A, -1AA□A, -1EA□A, -44A□B, and -60A□B motors do not contain End Bell (manufactured by Japan Aviation Electronics Industry, Ltd.). For these motors, use flexible conduit instead.

	Motor Model	Receptacle	Plug	End Bell: Manufactured by Japan Aviation Electronics Industry, Ltd. Back Shell: Manufactured by Daiichi Denshi Kogyo K.K.		Cable Clamp	Manufacturer
				Angle (L-shaped)	Straight		
Motors	SGMD- 22A□A 32A□A 40A□A	JL04V-2E24-1 0PE-B	JL04V-6A24-1 0SE	JL04-24EBL	JL04-24EB	JL04-2428CK (17)	Japan Aviation Electronics Industry, Ltd.

Connector on motor side already provided
To be prepared by customer (cable)

- * 1. Holding brakes are applicable to both L-shaped and straight types (manufactured by Daiichi Denshi Kogyo K.K.).
- * 2. The SGMG-55A□A, -75A□A, -1AA□A, -1EA□A, -44A□B, and -60A□B motors do not contain End Bell (manufactured by Japan Aviation Electronics Industry, Ltd.). For these motors, use flexible conduit instead.

Note: 1. To ensure compliance with IP67, always use correct combinations of receptacles and plugs.

2. When flexible conduit is used, select plug only.

**MS(D190) Series: Plug for Conduit
MS3106A20-29S (D190)**

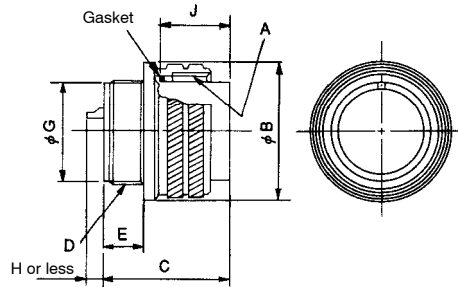

Unit: mm (in)

Shell Size	A	B ⁺⁰ _{-0.38} (-0.0150)	C ^{±0.5} (±0.0197)	D	E ^{±0.3} (±0.0118)	G ^{+0.05} (+0.0020) ^{-0.25} (-0.0098)	J ^{±0.12} (±0.0047)
10SL	5/8-24UNEF-2B	22.22 (0.87)	23.3 (0.92)	9/16-24UNEF-2A	7.5 (0.30)	12.5 (0.49)	13.49 (0.53)
20	11/4-18UNEF-2B	37.28 (1.47)	34.11 (1.34)	11/18-18UNEF-2A	12.16 (0.48)	26.8 (1.06)	18.26 (0.72)

Made by Daiichi Denshi Kogyo K.K.

CE02-XXBS-S
Straight Back Shell (for MS(D190))

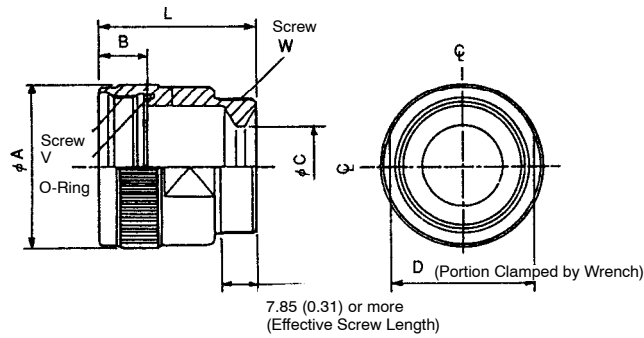

Unit: mm (in)

Shell Size	Part Number	L	A	B	C	D	V	W
18	CE02-18BS-S	31 (1.22)	30.5 (1.20)	10.5 (0.41)	16.3 (0.64)	26.7 (1.05)	1-20UNEF-2B	1-20UNEF-2A
20	CE02-20BS-S	35 (1.38)	35 (1.38)	10.9 (0.41)	17.8 (0.70)	31.6 (1.24)	11/8-18UNEF-2B	13/16-18UNEF-2A

Made by Daiichi Denshi Kogyo K.K.

CE-XXBA-S (XXX)
Angle Back Shell (for MS(D190))

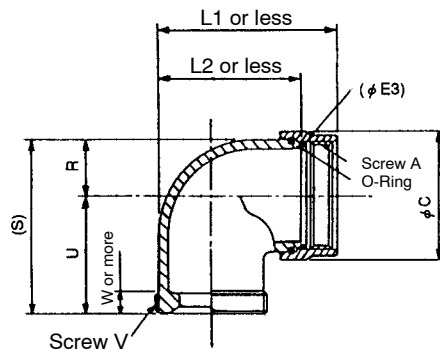

Unit: mm (in)

Part Number	Shell Size	Joint Screw A	Overall Length L1	Overall Length of Angle Body L2	Outside Diameter of Coupling C	R	V	(S)	Cable Clamp Set Screw V	Effective Screw Length W
CE-10SLBA-S	10SL	9/16-24UNEF-2B	30.6 (1.20)	22.5 (0.89)	21.7 (0.85)	7.9 (0.31)	21 (0.83)	(28.9) (1.14)	5/8-24UNEF-2A	7.5 (0.30)
CE-18BA-S	18	1-20UNEF-2B	44.6 (1.76)	34 (1.34)	32.4 (1.28)	13.2 (0.52)	30.2 (1.19)	(43.4) (1.71)	1-20UNEF-2A	7.5 (0.30)
CE-20BA-S	20	11/18UNEF-2B	50.5 (1.99)	39.6 (1.56)	36 (1.42)	15 (0.59)	33.3 (1.31)	(48.3) (1.90)	13/16-UNEF-2A	7.5 (0.30)

Made by Daiichi Denshi Kogyo K.K.

CE3057-XXA (for MS(D190))
Waterproof Cable Clamp (with Rubber Bushing)

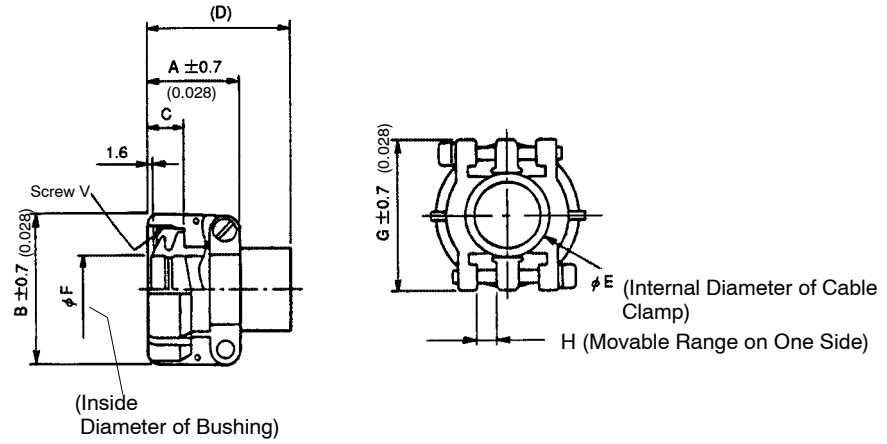

Unit: mm (in)

Part Number	Shell Size	Overall Length A	Outside Diameter B	Effective Screw Length C	(D)	E	F	G	H	Set Screw V	Attached Bushing	Cable Size (for reference)	
CE3057-4A-1	10SL	20.6 (0.81)	20.6 (0.81)	10.3 (0.41)	41.3 (1.63)	7.9 (0.31)	5.6 (0.22)	22.2 (0.87)	1.6 (0.06)	5/8-24UN EF-2B	CE3420-4-1	φ3.6 (0.14) to φ5.6 (0.22)	
CE3057-10A-1	18	23.8 (0.94)	30.1 (1.19)	10.3 (0.41)	41.3 (1.63)	15.9 (0.63)	14.1 (0.56)	31.7 (1.25)	3.2 (0.13)	1-20UNEF-2B	CE3420-10-1	φ10.5 (0.41) to φ14.1 (0.56)	
CE3057-10A-2							11.6 (0.46)					CE3420-10-2	φ8.5 (0.25) to φ11 (0.43)
CE3057-10A-3							8.7 (0.34)					CE3420-10-3	φ5.5 (0.22) to φ9.7 (0.38)
CE3057-12A-1	20 22	23.8 (0.94)	35 (1.38)	10.3 (0.41)	41.3 (1.63)	19 (0.75)	16 (0.63)	37.3 (1.47)	4 (0.16)	13/16-18U NEF-2B	CE3420-12-1	φ12.5 (0.49) to φ16 (0.63)	
CE3057-12A-2							13 (0.51)					CE3420-12-2	φ9.5 (0.37) to φ13 (0.51)
CE3057-12A-3							10 (0.38)					CE3420-12-3	φ5.5 (0.22) to φ9.7 (0.38)
CE3057-16A-1	24 28	26.2 (1.03)	42.1 (1.66)	10.3 (0.41)	41.3 (1.63)	23.8 (0.94)	19.1 (0.75)	42.9 (1.69)	4.8 (0.19)	17/16-18U NEF-2B	CE3420-16-1	φ15 (0.59) to φ19.1 (0.75)	
CE3057-16A-2							15.5 (0.61)					CE3420-16-2	φ13 (0.51) to φ15.5 (0.61)

Made by Daiichi Denshi Kogyo K.K.

Plug: JL04-6A

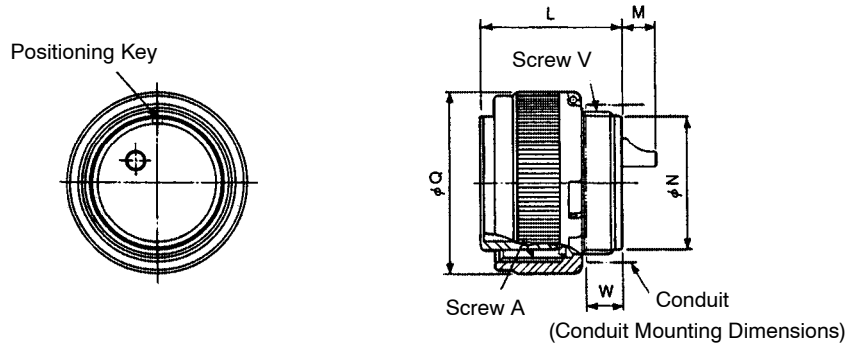

Unit: mm (in)

Shell Size	No. of Cores	Parts Name	Joint Screw	L ± 0.4 (0.0157)	M ± 0.8 (0.0315)	N ± 0.2 (0.0079)	Q ± 0.8 (0.0315)	Screw V	W (max)
22	4	JL04-6A22-22S	13/8-18UNEF-2B	31.5 (1.24)	7.6 (0.30)	29.6 (1.17)	40.5 (1.59)	11/4-18UNEF-2A	8 (0.31)
24	7	JL04-6A24-10S	11/2-18UNEF-2B	35 (1.38)	5.9 (0.23)	32.8 (1.29)	43.7 (1.72)	13/8-18UNEF-2A	10 (0.39)

Made by Japan Aviation Electronics Industry, Ltd.

Plug: JL04V-6A

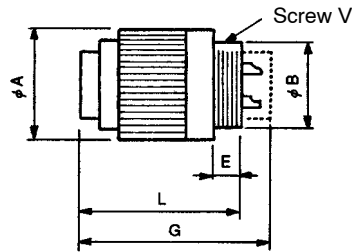

Unit: mm (in)

Shell Size	Screw V	φA	φB	L	E (max)	G
20	11/8-18UNEF-2A	37.3 ± 0.8 (1.47 ± 0.0315)	27 ± 0.2 (1.06 ± 0.0079)	31.5 ± 0.4 (1.24 ± 0.0157)	8 (0.32)	-
32	17/8-16UN-2A	56.3 ± 0.8 (22.2 ± 0.0315)	45.4 ± 0.2 (1.79 ± 0.0079)	35.8 ± 0.4 (1.41 ± 0.0157)	10 (0.39)	-

Made by Japan Aviation Electronics Industry, Ltd.

End Bell (Straight): JL04-□□EB

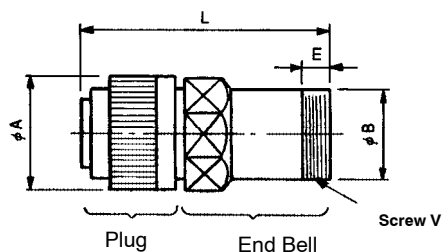

Unit: mm (in)

Shell Size	Screw V	ϕA	ϕB	L	E (min)
20	13/16-18UNEF-2A	37.3 ± 0.8 (1.47 ± 0.0315)	30.05 ± 0.2 (1.18 ± 0.0079)	67.9 ± 0.8 (2.67 ± 0.0315)	8 (032)
22	13/16-18UNEF-2A	40.5 ± 0.8 (1.59 ± 0.0315)	30.05 ± 0.2 (1.18 ± 0.0079)	67.63 ± 0.8 (2.66 ± 0.0315)	8 (0.32)
24	17/16-18UNEF-2A	43.7 ± 0.8 (1.72 ± 0.0315)	36.4 ± 0.2 (1.43 ± 0.0079)	71 ± 0.8 (2.80 ± 0.0315)	8 (0.32)

Made by Japan Aviation Electronics Industry, Ltd.

End Bell (L-shaped): JL04-□□EBL

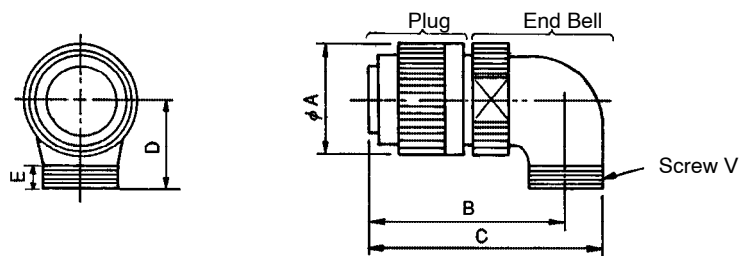

Unit: mm (in)

Shell Size	Screw V	ϕA	B	C	D	E
20	13/16-18UNEF-2A	37.3 ± 0.8 (1.47 ± 0.0315)	60.5 ± 0.8 (2.38 ± 0.0315)	74.2 ± 0.8 (2.92 ± 0.0315)	32 ± 0.8 (1.26 ± 0.0315)	10 ± 0.5 (0.39 ± 0.0197)
22	13/16-18UNEF-2A	40.5 ± 0.8 (1.59 ± 0.0315)	60.23 ± 0.8 (2.37 ± 0.0315)	73.93 ± 0.8 (2.91 ± 0.0315)	32 ± 0.8 (1.26 ± 0.0315)	10 ± 0.5 (0.39 ± 0.0197)
24	17/16-18UNEF-2A	43.7 ± 0.8 (1.72 ± 0.0315)	65 ± 0.8 (2.56 ± 0.0315)	82 ± 0.8 (3.23 ± 0.0315)	38 ± 0.8 (1.50 ± 0.0315)	10 ± 0.5 (0.39 ± 0.0197)

Cable Clamp: JL04-□CK(**)

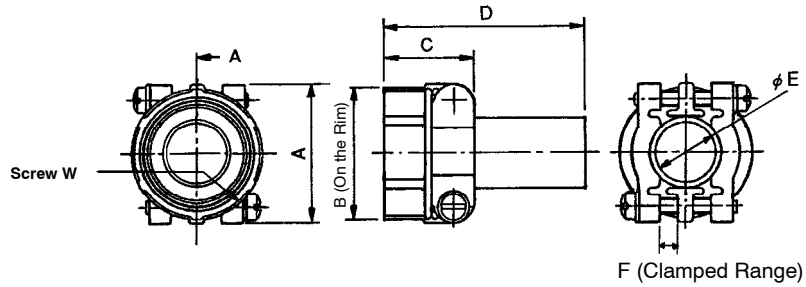

Unit: mm (in)

Parts Name/Size	A \pm 0.8 (\pm 0.0315)	B \pm 0.8 (\pm 0.0315)	C \pm 0.8 (\pm 0.0315)	D \pm 0.8 (\pm 0.0315)	ϕ E \pm 0.8 (\pm 0.0315)	F	Screw W	Cable Size
JL04-2022CK(14)	37.3 (1.47)	34.9 (1.37)	24.3 (0.96)	53.8 (2.11)	15.9 (0.63)	4 (0.16)	13/16-18UNEF-2B	ϕ 12.9 (0.51) to ϕ 15.9 (0.63)
JL04-2428CK(17)	42.9 (42.9)	42.1 (1.66)	26.2 (1.03)	56.2 (2.21)	18 (0.71)	4.8 (0.19)	17/16-18UNEF-2B	ϕ 15 (0.59) to ϕ 18 (0.71)

■ For the SGM and SGMP Models

Connector kit comprises three connectors as shown in the diagram below: one encoder connector at both the motor and SERVOPACK ends of the cable and a motor connector for the motor end of the cable.

Encoder Connector for Motor End of Cable

Encoder Connector for SERVOPACK End of Cable

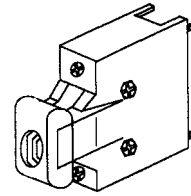
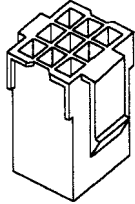

Main Circuit (Power Line) Connector on Motor Side

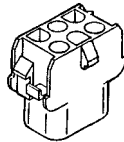

Four models of connector kit are available according to the following criteria:

- Incremental encoder or absolute encoder
- Motor with or without a brake

A connector kit is required in the following cases:

- If motor cable only is purchased (whether or not motor has a brake).
- If the encoder cable with a motor connector only and SERVOPACK end without connector, or encoder cable only is purchased (for either incremental or absolute encoder).

Encoder Cable Connectors

Select one of the following two types of encoder cable connector.

- For Incremental Encoders

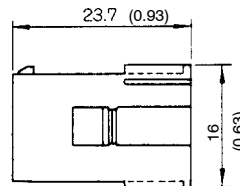
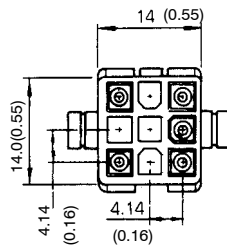

Cap: 172161-1
Socket: 170365-1

- For Absolute Encoders

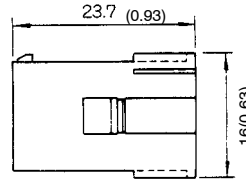
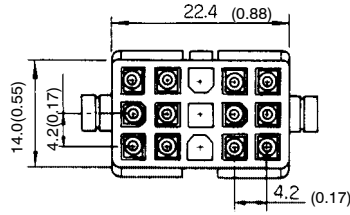

Cap: 172163-1
Socket: 170361-1 or 170365-1

Motor Cable Connectors (Excluding SGMP-15A)

Select one of the following two types for motor cable connector.

- Motors Without Brakes

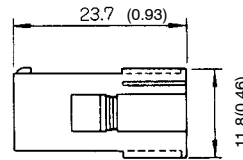
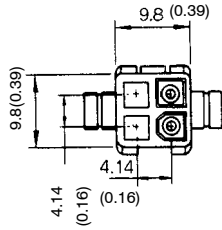

Cap: 172159-1
Socket: 170362-1 or 170366-1

- Motor With Brake

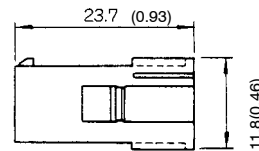
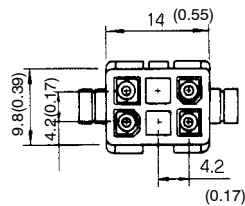

Cap: 172160-1
Socket: 170362-1 or 170366-1

■ For the SGMP-15A Model Only

The connector shape differs between motors with brakes.

- Motors without Brakes

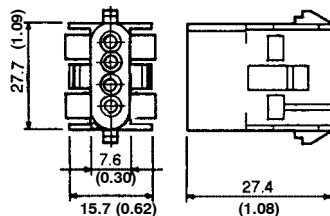

Cap: 350780-1
Socket: 350536-6 or 350550-6

● Motors with Brakes

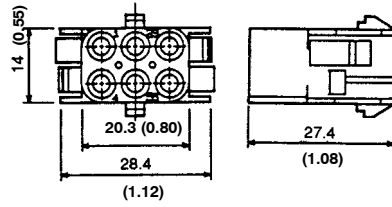

Cap: 350781-1
 Socket: 350536-6 or 350550-6

■ Common to the SGMG, SGMS, SGMD, SGM and SGMP Models

Only one model of encoder connector is available for the SERVOPACK end of the cable.

● Connector

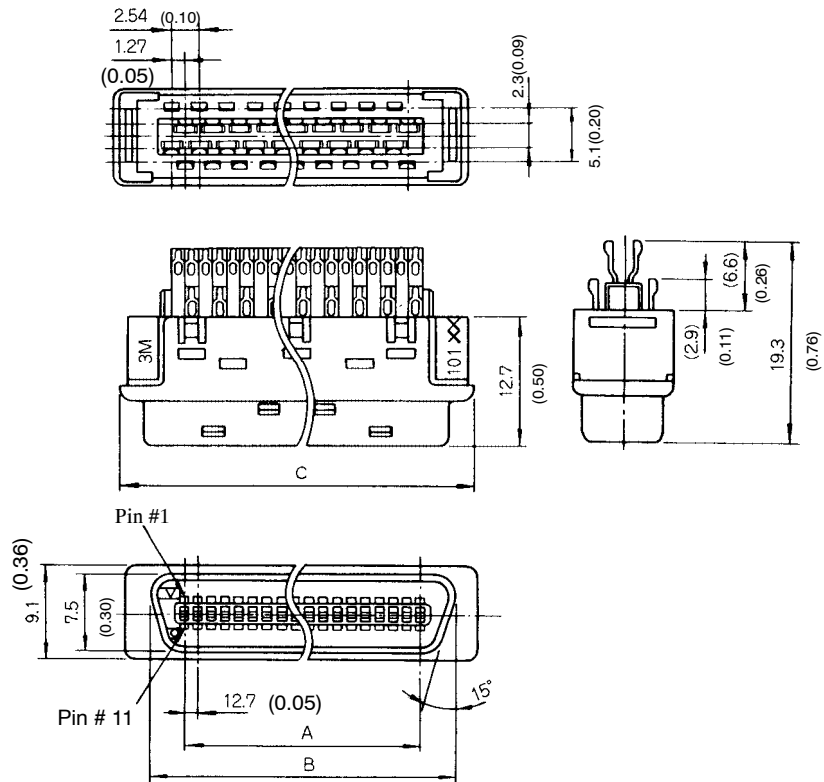

Unit: mm (in)

Connector Model	A	B	C
10120-3000VE	11.43 (0.45)	17.6 (0.69)	22.0 (0.87)

Manufactured by 3M.

6.6.3 Connector

- Case

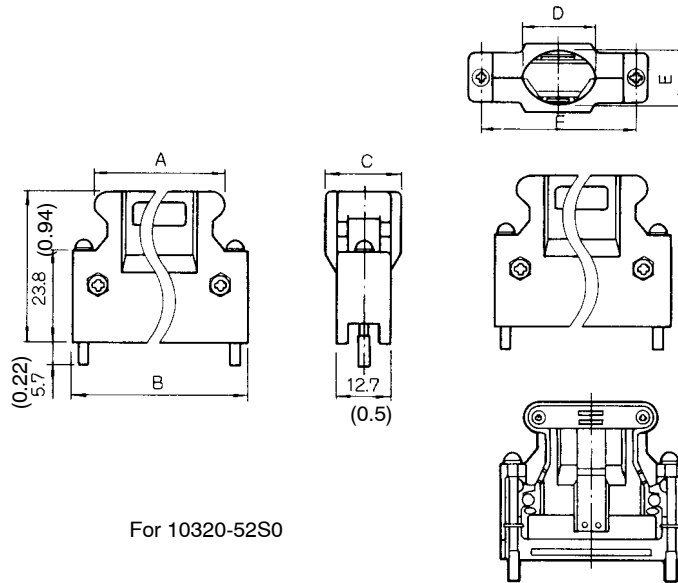

Diagram of Assembled Connector (for reference)

Unit: mm (in)

Connector Model	Case	A	B	C	D	E	F
DE9411290	10320-52S0-00S	22.0 (0.87)	33.3 (1.31)	14.0 (0.55)	12.0 (0.47)	10.0 (0.39)	27.4 (1.08)

Manufactured by 3M.

Connector Combinations (Excluding SGMP-15A)

- For the SGM and SGMP Models

Connector combinations for the SGM and SGMP Servomotors are shown in the following table. Combine these with the models selected in the previous section (pages 6 -211 to 6 -214).

Table 6.24 Connector Combinations for SGM and SGMP Servomotors

Connector Kit Model	Application		Connector Kit Part List											
	Encoder/Motor Cable		For Encoder Cable								For Motor Cable			
			Encoder End				SERVOPACK End							
	Encoder Type	Motor Brake With/Without	Cap		Socket		Connector		Case		Cap		Socket	
Model			Qty	Model	Qty	Model	Qty	Model	Qty	Model	Qty	Model	Qty	
DP9420006-1	Incremental	Without	*1 172161 -1	1	*1 170365 -1	*3 10	*2 10120-3000VE	1	*2 10320-52S0-00S	1	*1 172159 -1	1	*1 170366 -1	*3 5
DP9420006-2	Incremental	With									*1 172160 -1	1		*3 7
DP9420006-3	Absolute	Without	*1 172163 -1	1		*3 16					*1 172159 -1	1		*3 5
DP9420006-4	Absolute	With									*1 172160 -1	1		*3 7

* 1. Manufactured by AMP.

* 2. Manufactured by 3M.

* 3. Including one spare.

- For SGMP-15A Model Only

Connector combinations for the SGMP-15A Servomotor are shown in the following table.

Table 6.25 Connector Combinations for SGMP-15A Servomotor

Connector Kit Model	Application		Connector Kit Part List											
	Encoder/Motor Cable		For Encoder Cable								For Motor Cable			
			Encoder End				SERVOPACK End							
	Encoder Type	Motor Brake With/Without	Cap		Socket		Connector		Case		Cap		Socket	
Model			Qty	Model	Qty	Model	Qty	Model	Qty	Model	Qty	Model	Qty	
DP9420016-1	Incremental	Without	*1 172161 -1	1	*1 170365 -1	*3 10	*2 10120- 3000VE	1	*2 10320- 52S0- 00S	1	*1 350780 -1	1	*1 350550 -6	*3 5
DP9420016-2	Incremental	With									*1 350781 -1	1		*3 7
DP9420016-3	Absolute	Without	*1 172163 -1	1		*3 16					*1 350780 -1	1		*3 5
DP9420016-4	Absolute	With									*1 350781 -1	1		*3 7

- * 1. Manufactured by AMP.
- * 2. Manufactured by 3M.
- * 3. Including one spare.

6.6.4 Brake Power Supply

Brake power supplies are available for 200 V and 100 V input. Use for Servomotor with brake.

200 VAC Input: LPSE-2H01 (90 VDC Output)

100 VAC Input: LPDE-1H01 (90 VDC Output)

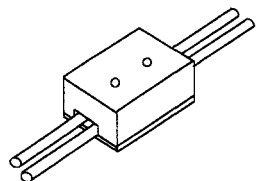

Note: 24 VDC brake power supply unit is not provided. When using a 24-VDC servomotor with brake, the brake power supply unit must be provided by the customer.

■ Dimensional Drawings

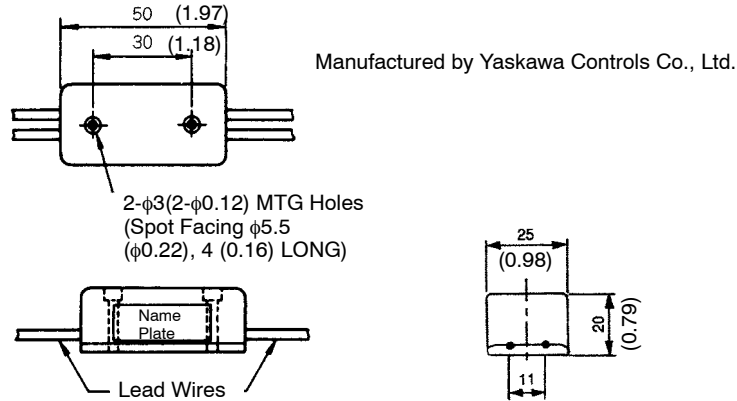

■ Specifications

- Rated Output Voltage: 90 VDC
- Maximum Output Current: 1.0 ADC
- Lead Wire Length: 500 mm each (19.69 in.)
- Max. Ambient Temperature: 60°C

AC Input		Brake
100V	200V	
Blue/White	Yellow/White	Red/Black

■ Internal Circuit

The internal circuits are shown below. While it is possible to switch either the AC or DC side of the brake power supply, it is normally safer to switch the AC side.

IMPORTANT

If the DC side is to be switched, install a surge suppressor near the brake coil to prevent the surge voltages due to switching the DC side damaging the brake coil.

Brake operation time delay occurs during brake power supply ON/OFF operation. Set output timing of servo OFF operation (motor output stop), referring to 3.14.2 Holding Brake . E specially, if the AC side of the brake power supply is to be switched, brake operation time is extended.

- Internal Circuit for 200 VAC Input (LPSE-2H01)

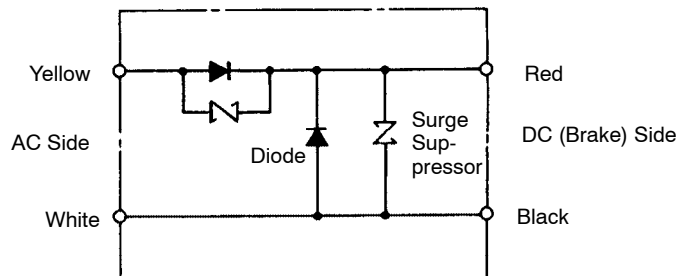

- Internal Circuit for 100 VAC Input (LPDE-1H01)

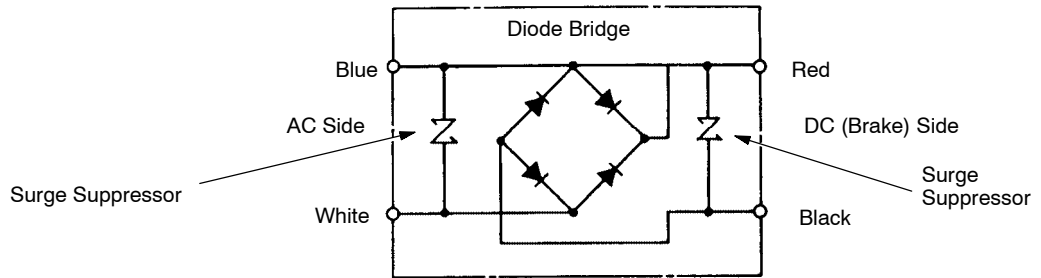

6.6.5 Encoder Cables

Encoder cables are used to connect encoders on servomotors to SERVOPACKs.

The dimensions and appearance of the encoder cables are shown below. Specify the cable model when ordering.

■ For the SGMG, SGMS and SGMD Models

Cables for Incremental Encoders (with Straight Plugs)

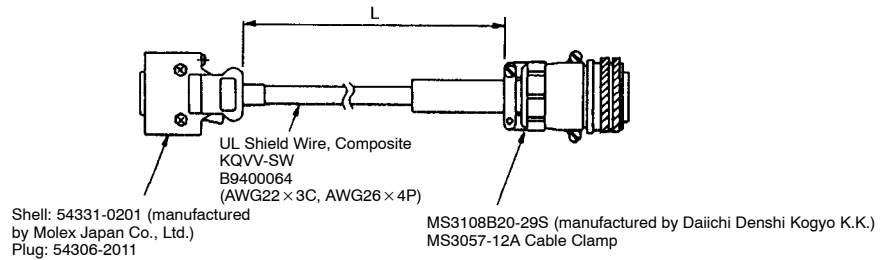

Cable Model	L in mm (feet)
JZSP-CBP0S-01	$3000 \begin{matrix} + 100 \\ 0 \end{matrix}$ ($10 \begin{matrix} + 0.33 \\ 0 \end{matrix}$)
JZSP-CBP0S-02	$5000 \begin{matrix} + 100 \\ 0 \end{matrix}$ ($16.7 \begin{matrix} + 0.33 \\ 0 \end{matrix}$)
JZSP-CBP0S-03	$10000 \begin{matrix} + 500 \\ 0 \end{matrix}$ ($33.3 \begin{matrix} + 1.67 \\ 0 \end{matrix}$)
JZSP-CBP0S-04	$15000 \begin{matrix} + 500 \\ 0 \end{matrix}$ ($50 \begin{matrix} + 1.67 \\ 0 \end{matrix}$)
JZSP-CBP0S-05	$20000 \begin{matrix} + 500 \\ 0 \end{matrix}$ ($66.7 \begin{matrix} + 1.67 \\ 0 \end{matrix}$)

Cables for Incremental Encoders (with L-shaped Plugs)

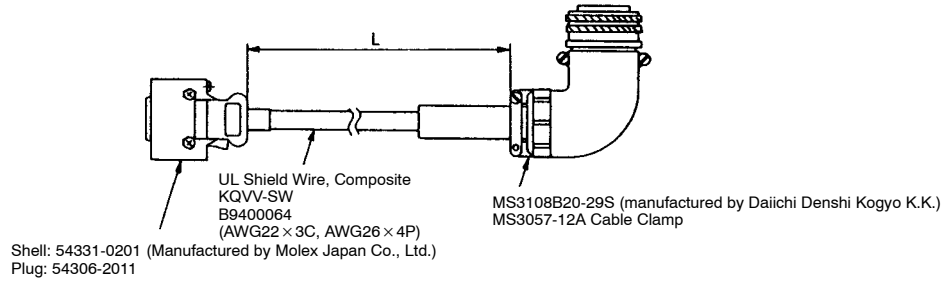

Cable Model	L in mm (feet)
JZSP-CBP0L-01	3000 $\begin{matrix} + 100 \\ 0 \end{matrix}$ (10 $\begin{matrix} + 0.33 \\ 0 \end{matrix}$)
JZSP-CBP0L-02	5000 $\begin{matrix} + 100 \\ 0 \end{matrix}$ (16.7 $\begin{matrix} + 0.33 \\ 0 \end{matrix}$)
JZSP-CBP0L-03	10000 $\begin{matrix} + 500 \\ 0 \end{matrix}$ (33.3 $\begin{matrix} + 1.67 \\ 0 \end{matrix}$)
JZSP-CBP0L-04	15000 $\begin{matrix} + 500 \\ 0 \end{matrix}$ (50 $\begin{matrix} + 1.67 \\ 0 \end{matrix}$)
JZSP-CBP0L-05	20000 $\begin{matrix} + 500 \\ 0 \end{matrix}$ (66.7 $\begin{matrix} + 1.67 \\ 0 \end{matrix}$)

Cables for Incremental Encoders (without Connector on Encoder End)

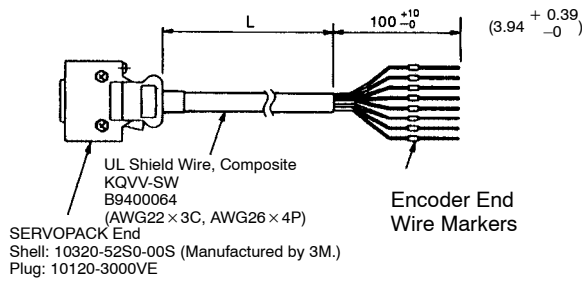

Cable Model	L in mm (feet)
DE9411276-1	3000 $\begin{matrix} + 100 \\ 0 \end{matrix}$ (10 $\begin{matrix} + 0.33 \\ 0 \end{matrix}$)
DE9411276-2	5000 $\begin{matrix} + 100 \\ 0 \end{matrix}$ (16.7 $\begin{matrix} + 0.33 \\ 0 \end{matrix}$)
DE9411276-3	10000 $\begin{matrix} + 500 \\ 0 \end{matrix}$ (33.3 $\begin{matrix} + 1.67 \\ 0 \end{matrix}$)
DE9411276-4	15000 $\begin{matrix} + 500 \\ 0 \end{matrix}$ (50 $\begin{matrix} + 1.67 \\ 0 \end{matrix}$)
DE9411276-5	20000 $\begin{matrix} + 500 \\ 0 \end{matrix}$ (66.7 $\begin{matrix} + 1.67 \\ 0 \end{matrix}$)

6.6.5 Encoder Cables

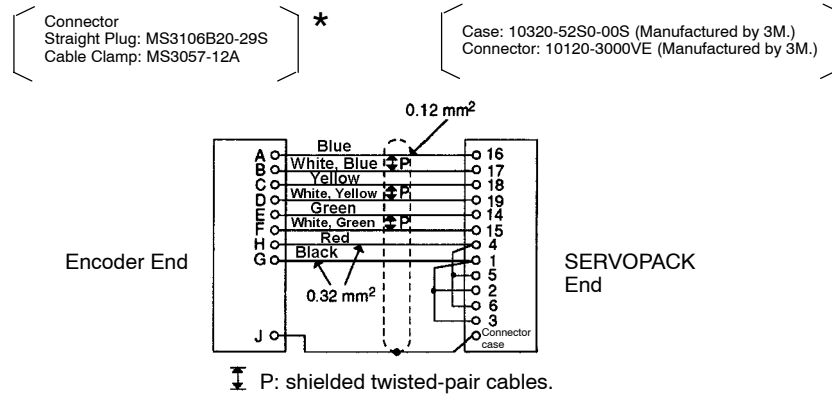

* Purchase cases and connectors separately. Refer to 6.6.3 Connector for details.

Cables for Absolute Encoders (with Straight Plugs)

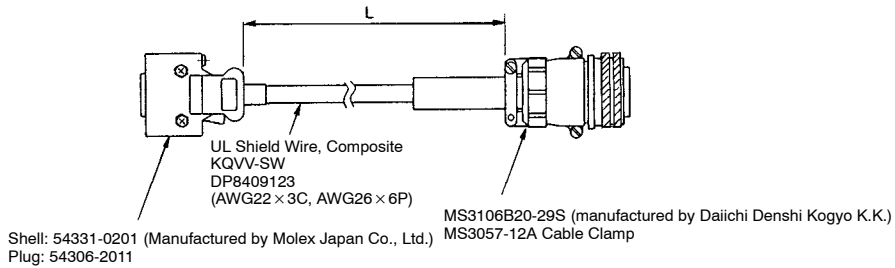

Cable Model	L in mm (feet)
JZSP-CBP1S-01	3000 + 100 0 (10 + 0.33 0)
JZSP-CBP1S-02	5000 + 100 0 (16.7 + 0.33 0)
JZSP-CBP1S-03	10000 + 500 0 (33.3 + 1.67 0)
JZSP-CBP1S-04	15000 + 500 0 (50 + 1.67 0)
JZSP-CBP1S-05	20000 + 500 0 (66.7 + 1.67 0)

Cables for Absolute Encoders (with L-shaped Plugs)

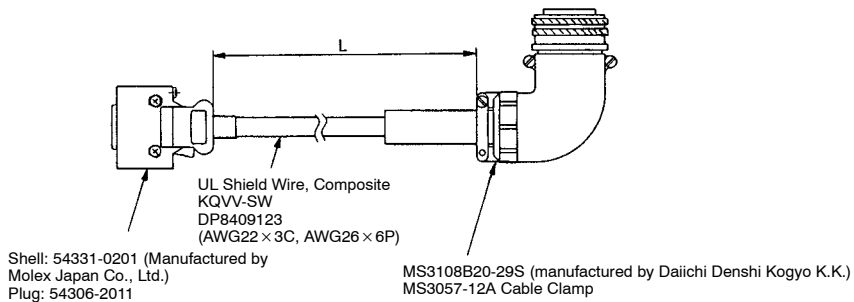

Cable Model	L in mm (feet)
JZSP-CBP1L-01	3000 $\begin{smallmatrix} +100 \\ 0 \end{smallmatrix}$ (10 $\begin{smallmatrix} +0.33 \\ 0 \end{smallmatrix}$)
JZSP-CBP1L-02	5000 $\begin{smallmatrix} +100 \\ 0 \end{smallmatrix}$ (16.7 $\begin{smallmatrix} +0.33 \\ 0 \end{smallmatrix}$)
JZSP-CBP1L-03	10000 $\begin{smallmatrix} +500 \\ 0 \end{smallmatrix}$ (33.3 $\begin{smallmatrix} +1.67 \\ 0 \end{smallmatrix}$)
JZSP-CBP1L-04	15000 $\begin{smallmatrix} +500 \\ 0 \end{smallmatrix}$ (50 $\begin{smallmatrix} +1.67 \\ 0 \end{smallmatrix}$)
JZSP-CBP1L-05	20000 $\begin{smallmatrix} +500 \\ 0 \end{smallmatrix}$ (66.7 $\begin{smallmatrix} +1.67 \\ 0 \end{smallmatrix}$)

Cables for Absolute Encoders (without Connector on Encoder End)

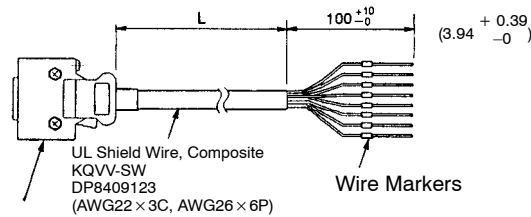

Shell: 10320-52S0-00S (Manufactured by 3M.)
Plug: 10120-3000VE

Cable Model	L in mm (feet)
DE9411277-1	3000 $\begin{smallmatrix} +100 \\ 0 \end{smallmatrix}$ (10 $\begin{smallmatrix} +0.33 \\ 0 \end{smallmatrix}$)
DE9411277-2	5000 $\begin{smallmatrix} +100 \\ 0 \end{smallmatrix}$ (16.7 $\begin{smallmatrix} +0.33 \\ 0 \end{smallmatrix}$)
DE9411277-3	10000 $\begin{smallmatrix} +500 \\ 0 \end{smallmatrix}$ (33.3 $\begin{smallmatrix} +1.67 \\ 0 \end{smallmatrix}$)
DE9411277-4	15000 $\begin{smallmatrix} +500 \\ 0 \end{smallmatrix}$ (50 $\begin{smallmatrix} +1.67 \\ 0 \end{smallmatrix}$)
DE9411277-5	20000 $\begin{smallmatrix} +500 \\ 0 \end{smallmatrix}$ (66.7 $\begin{smallmatrix} +1.67 \\ 0 \end{smallmatrix}$)

6.6.5 Encoder Cables

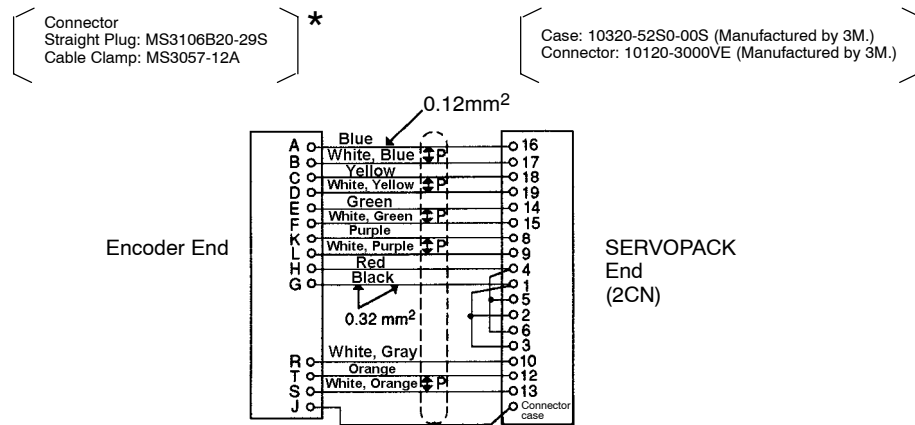

⊥ P: shielded twisted-pair cables.

* Purchase cases and connectors separately. Refer to 6.6.3 Connector for details.

Cables for Incremental Encoders (Cable Only)

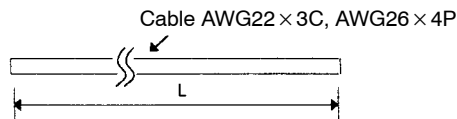

Cable Model	L in mm (feet)
B9400064-1	3000 ^{+ 100} ₀ (10 ^{+ 0.33} ₀)
B9400064-2	5000 ^{+ 100} ₀ (16.7 ^{+ 0.33} ₀)
B9400064-3	10000 ^{+ 500} ₀ (33.3 ^{+ 1.67} ₀)
B9400064-4	15000 ^{+ 500} ₀ (50 ^{+ 1.67} ₀)
B9400064-5	20000 ^{+ 500} ₀ (66.7 ^{+ 1.67} ₀)

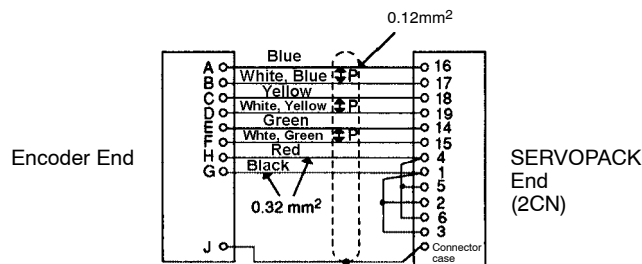

⊥ P: shielded twisted-pair cables.

* Purchase plugs, cable clamps, cases, and connectors separately. Refer to 6.6.3 Connector for details.

Cables for Absolute Encoders (Cable Only)

Cable AWG22 × 3C, AWG26 × 6P

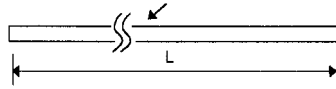

Cable Model	L in mm (feet)
DP8409123-1	3000 ^{+ 100} ₀ (10 ^{+ 0.33} ₀)
DP8409123-2	5000 ^{+ 100} ₀ (16.7 ^{+ 0.33} ₀)
DP8409123-3	10000 ^{+ 500} ₀ (33.3 ^{+ 1.67} ₀)
DP8409123-4	15000 ^{+ 500} ₀ (50 ^{+ 1.67} ₀)
DP8409123-5	20000 ^{+ 500} ₀ (66.7 ^{+ 1.67} ₀)

Connector
Straight Plug: MS3106B20-29S
Cable Clamp: MS3057-12A

Case: 10320-52S0-00S (Manufactured by 3M.)
Connector: 10120-3000VE (Manufactured by 3M.)

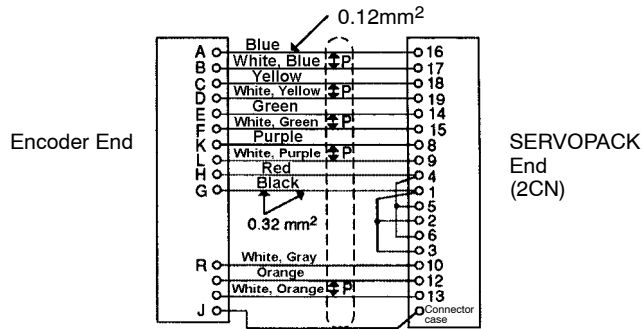

⊘ P: shielded twisted-pair cables.

* Purchase plugs, cable clamps, cases, and connectors separately. Refer to 6.6.3 Connector for details.

■ For the SGM and SGMP

Cables for Incremental Encoders (Connectors Both Ends)

Connector for Encoder End of Cable
Cap: 172161-1 (9-pin)
Socket: 170361-1 or 170365-1

SERVOPACK End of Cable
Case: 54331-0201
Connector: 54306-2011

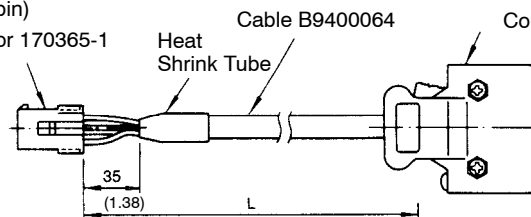

Cable Model	L in mm (feet)
JZSP-CAP00-01	$3000 \begin{smallmatrix} + 100 \\ 0 \end{smallmatrix}$ ($10 \begin{smallmatrix} + 0.33 \\ 0 \end{smallmatrix}$)
JZSP-CAP00-02	$5000 \begin{smallmatrix} + 100 \\ 0 \end{smallmatrix}$ ($16.7 \begin{smallmatrix} + 0.33 \\ 0 \end{smallmatrix}$)
JZSP-CAP00-03	$10000 \begin{smallmatrix} + 500 \\ 0 \end{smallmatrix}$ ($33.3 \begin{smallmatrix} + 1.67 \\ 0 \end{smallmatrix}$)
JZSP-CAP00-04	$15000 \begin{smallmatrix} + 500 \\ 0 \end{smallmatrix}$ ($50 \begin{smallmatrix} + 1.67 \\ 0 \end{smallmatrix}$)
JZSP-CAP00-05	$20000 \begin{smallmatrix} + 500 \\ 0 \end{smallmatrix}$ ($66.7 \begin{smallmatrix} + 1.67 \\ 0 \end{smallmatrix}$)

Cables for Absolute Encoders (Connectors on Both Ends)

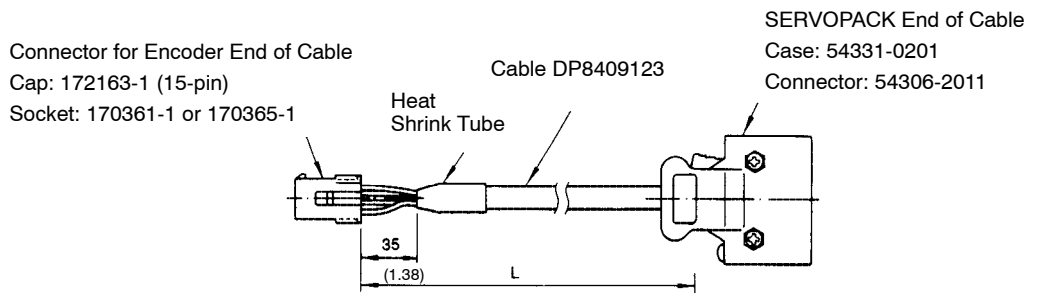

Cable Model	L in mm (feet)
JZSP-CAP10-01	$3000 \begin{smallmatrix} + 100 \\ 0 \end{smallmatrix}$ ($10 \begin{smallmatrix} + 0.33 \\ 0 \end{smallmatrix}$)
JZSP-CAP10-02	$5000 \begin{smallmatrix} + 100 \\ 0 \end{smallmatrix}$ ($16.7 \begin{smallmatrix} + 0.33 \\ 0 \end{smallmatrix}$)
JZSP-CAP10-03	$10000 \begin{smallmatrix} + 500 \\ 0 \end{smallmatrix}$ ($33.3 \begin{smallmatrix} + 1.67 \\ 0 \end{smallmatrix}$)
JZSP-CAP10-04	$15000 \begin{smallmatrix} + 500 \\ 0 \end{smallmatrix}$ ($50 \begin{smallmatrix} + 1.67 \\ 0 \end{smallmatrix}$)
JZSP-CAP10-05	$20000 \begin{smallmatrix} + 500 \\ 0 \end{smallmatrix}$ ($66.7 \begin{smallmatrix} + 1.67 \\ 0 \end{smallmatrix}$)

6

Cables for Incremental Encoders (without Connector on SERVOPACK End)

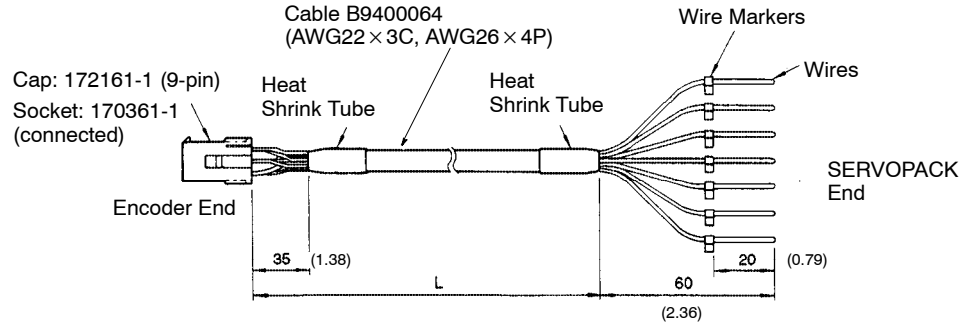

Cable Model	L in mm (feet)
DP9320086-1	3000 + 100 0 (10 + 0.33 0)
DP9320086-2	5000 + 100 0 (16.7 + 0.33 0)
DP9320086-3	10000 + 500 0 (33.3 + 1.67 0)
DP9320086-4	15000 + 500 0 (50 + 1.67 0)
DP9320086-5	20000 + 500 0 (66.7 + 1.67 0)

Case: 10320-52S0-00S (Manufactured by 3M.)
Connector: 10120-3000VE (Manufactured by 3M.) *

Cap: 172161-1
Socket: 170361-1

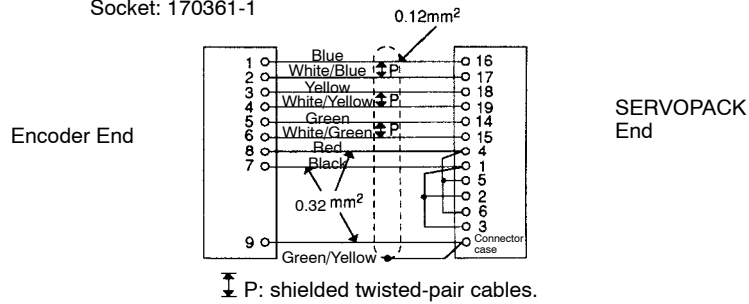

* Purchase cases and connectors separately. Refer to 6.6.3 Connector for details.

Cables for Absolute Encoders (without Connector on SERVOPACK End)

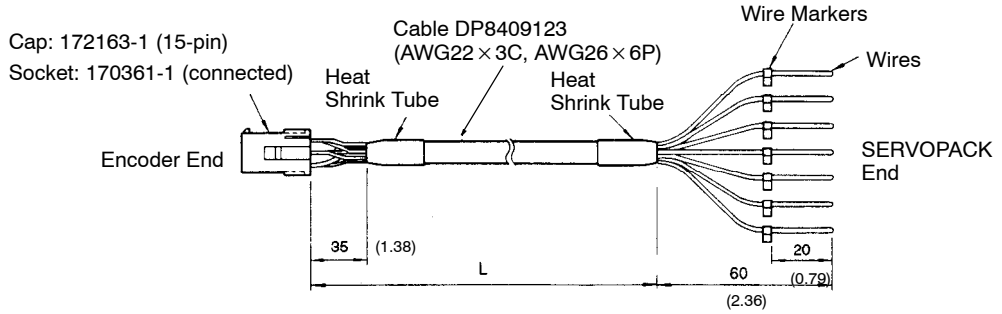

Cable Model	L in mm (feet)
DP9320085-1	3000 + 100 0 (10 + 0.33 0)
DP9320085-2	5000 + 100 0 (16.7 + 0.33 0)
DP9320085-3	10000 + 500 0 (33.3 + 1.67 0)
DP9320085-4	15000 + 500 0 (50 + 1.67 0)
DP9320085-5	20000 + 500 0 (66.7 + 1.67 0)

Case: 10320-52S0-00S (Manufactured by 3M.)
 Connector: 10120-3000VE (Manufactured by 3M.) *

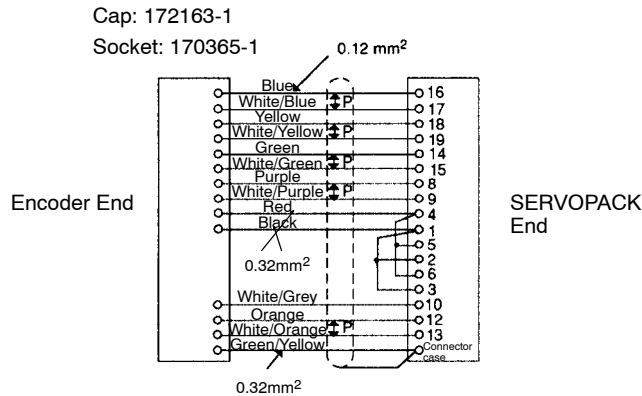

* Purchase cases and connectors separately. Refer to 6.6.3 Connector for details.

Cables for Incremental Encoders (Cable Only)

Cable AWG22 × 3C, AWG26 × 4P

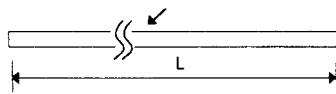

Cable Model	L in mm (feet)
B9400064-1	3000 ^{+ 100} ₀ (10 ^{+ 0.33} ₀)
B9400064-2	5000 ^{+ 100} ₀ (16.7 ^{+ 0.33} ₀)
B9400064-3	10000 ^{+ 500} ₀ (33.3 ^{+ 1.67} ₀)
B9400064-4	15000 ^{+ 500} ₀ (50 ^{+ 1.67} ₀)
B9400064-5	20000 ^{+ 500} ₀ (66.7 ^{+ 1.67} ₀)

Cap: 172161-1 (Manufactured by AMP.)
 Socket: 170361-1 or 170365-1
 (Manufactured by AMP.)

Case: 10320-52S0-00S (Manufactured by 3M.)
 Connector: 10120-3000VE (Manufactured by 3M.)

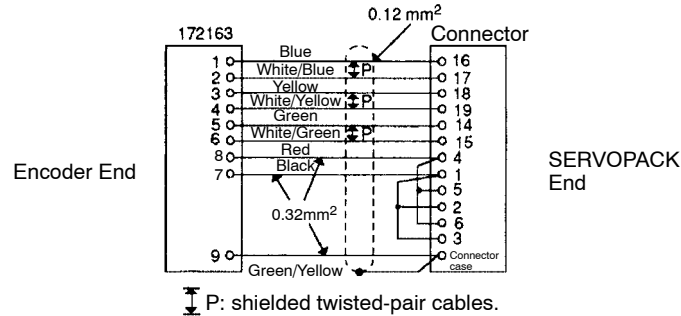

* Purchase caps, sockets, cases, and connectors separately. Refer to 6.6.3 Connector for details.

Cables for Absolute Encoders (Cable Only)

Cable AWG22 × 3C, AWG26 × 6P

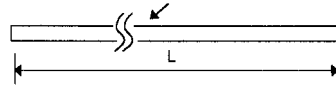

Cable Model	L in mm (feet)
DP8409123-1	3000 ^{+ 100} ₀ (10 ^{+ 0.33} ₀)
DP8409123-2	5000 ^{+ 100} ₀ (16.7 ^{+ 0.33} ₀)
DP8409123-3	10000 ^{+ 500} ₀ (33.3 ^{+ 1.67} ₀)

Cable Model	L in mm (feet)
DP8409123-4	15000 $\begin{matrix} + 500 \\ 0 \end{matrix}$ (50 $\begin{matrix} + 1.67 \\ 0 \end{matrix}$)
DP8409123-5	20000 $\begin{matrix} + 500 \\ 0 \end{matrix}$ (66.7 $\begin{matrix} + 1.67 \\ 0 \end{matrix}$)

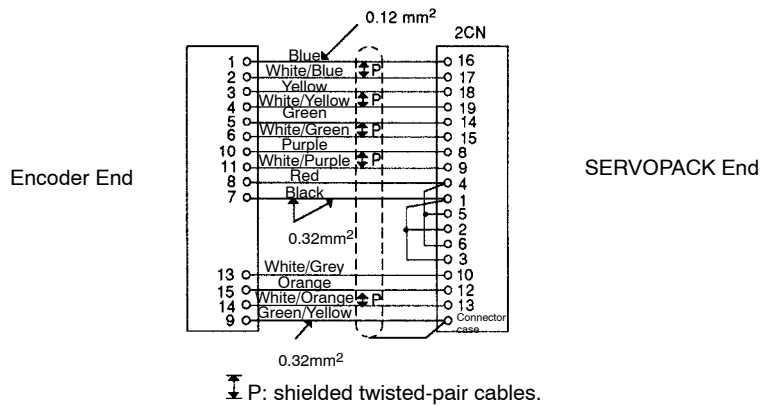
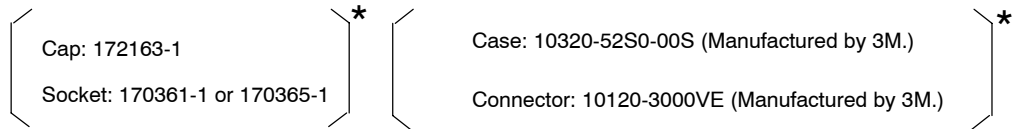

* Purchase caps, sockets, cases, and connectors separately. Refer to 6.6.3 Connector for details.

6

■ Specifications of Other Encoder Cables

Details of other encoder cables are summarized in the following table. These cables are not supplied as accessories with a SERVOPACK or Servomotor. Purchase in standard specified lengths as required.

Table 6.26 Specifications of Other Encoder Cables

Cable Specifications	Incremental Encoder (Yaskawa Drg. #B9400064)	Absolute Encoder (Yaskawa Drg. #DP8409123)
Basic Specifications	Compound KQVV-SW AWG22 × 3C, AWG26 × 4P	Compound KQVV-SW AWG22 × 3C, AWG26 × 6P
Finished Dimension	∅7.5 mm (∅0.30)	∅8.0 mm (∅0.31)

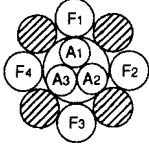
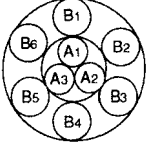
Cable Specifications	Incremental Encoder (Yaskawa Drg. #B9400064)	Absolute Encoder (Yaskawa Drg. #DP8409123)
Internal Structure and Lead Colors	 <p>A₁ Red A₂ Black A₃ Green/Yellow F₁ Blue - White/Blue (Twisted-pair) F₂ Yellow - White/Yellow (Twisted-pair) F₃ Green - White/Green (Twisted-pair) F₄ Orange - White/Orange (Twisted-pair)</p>	 <p>A₁ Red A₂ Black A₃ Green/Yellow B₁ Blue - White/Blue (Twisted-pair) B₂ Yellow - White/Yellow (Twisted-pair) B₃ Green - White/Green (Twisted-pair) B₄ Orange - White/Orange (Twisted-pair) B₅ Purple - White/Purple (Twisted-pair) B₆ Grey - White/Grey (Twisted-pair)</p>
Yaskawa standard specifications	Standard lengths: 3 m (9.8) , 5 m (16.4) , 10 m (32.8), 15 m (49.2), 20 m (65.6) *	

* When appropriate cable is used, the allowable wiring distance between SERVOPACK and Servomotor (PG) is 20 m (65.6) max.

6.6.6 Back-up Battery

The SGDB-AM SERVOPACK requires a back-up battery. This battery is used to back up various set memories and absolute encoders, and has a life of approximately 10 years. (This may vary according to service conditions.)

The battery is manufactured by Toshiba Battery Co., Ltd., and Yaskawa supplies a battery fitted with a connector. (One battery is supplied with each purchase of an SGDB-AM SERVOPACK.)

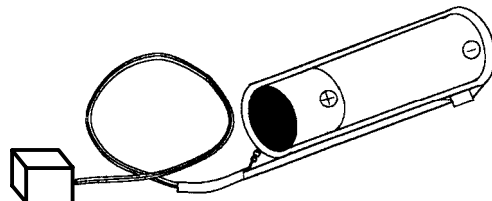

- Lithium Battery: ER6VLY + DF3 Connector
- Nominal Voltage: 3.6 V
- Standard Capacity: 2000 mAh

6.6.7 1CN and 6CN Connectors

1CN and 6CN connectors are used to connect a host controller to the SERVOPACK. They each consist of a connector and a case.

The dimensional diagrams and models are shown below.

■ Connector Models

Connector Model	Application	Connector Part List			
		Connector		Case	
		Model	Qty	Model	Qty
JZSP-VAI09	I/O Connector for 1CN	10136-3000VE*	1	10336-52S0-00S*	1 Set
DE9411289	I/O Connector for 6CN	10150-3000VE*	1	10350-52S0-00S*	1 Set

* Manufactured by 3M.

■ Dimensional Diagram

- Connector

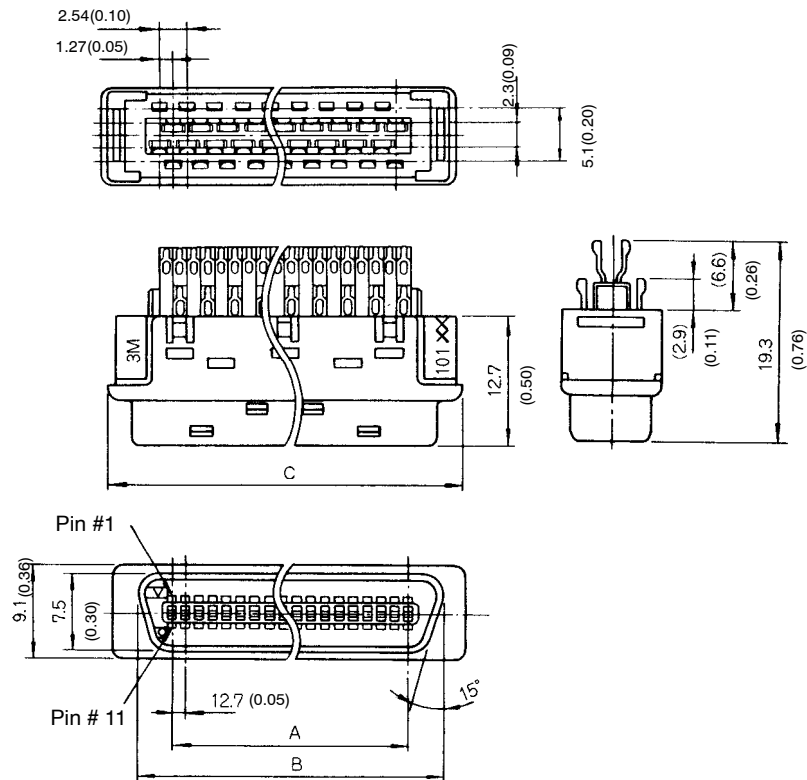

Unit: mm (in)

Connector Model	A	B	C
10136-3000VE	21.59 (0.85)	27.8 (1.09)	32.2 (1.27)
10150-3000VE	30.48 (1.20)	36.7 (1.44)	41.1 (1.62)

Manufactured by 3M.

• Case

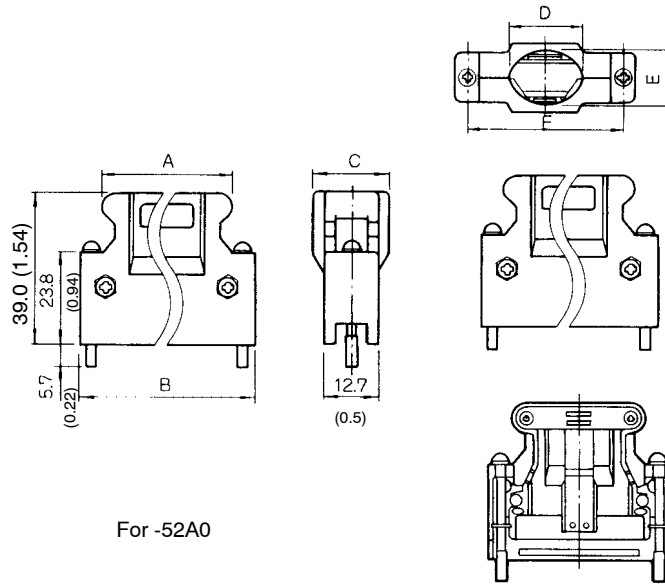

Diagram of Assembled Connector (for reference)

Unit: mm (in)

Connector Model	Case Model	A	B	C	D	E	F
10136-3000VE	10336-52S0-00S	32.2 (1.27)	43.5 (1.71)	18.0 (0.71)	17.0 (0.67)	14.0 (0.55)	37.6 (1.48)
10150-3000VE	10350-52S0-00S	41.1 (1.62)	52.4 (2.06)	18.0 (0.71)	17.0 (0.67)	14.0 (0.55)	46.5 (1.83)

Manufactured by 3M.

6.6.8 3CN Connector

A 3CN connector is used to connect the Digital Operator, the personal computer, and the external position indicator to the SERVOPACK.

■ Connector Models

Connector Kit Model	Application	Connector Kit Part List	
		Connector with Case	
		Model	Qty
DE9409459	Serial communication connector for 3CN	17JE-23090-02 (D8B)*	1 Set

* Manufactured by Daiichi Denshi Kogyo K.K.

■ Dimensional Diagram

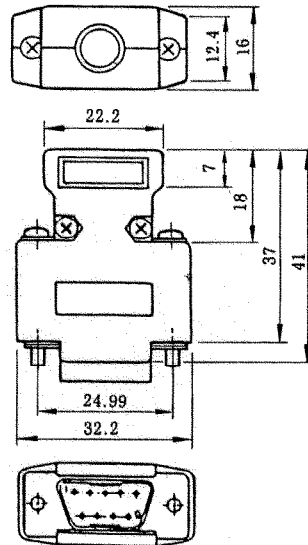

6

6.6.9 Connector-Terminal Block Conversion Unit

The connector-terminal block conversion unit comprises a cable with connectors and a terminal block. The terminal numbers of the terminal block match the connector pin numbers of the connector for the SERVOPACK side.

Connector-Terminal Block Conversion Unit is provided for both 1CN and 6CN.

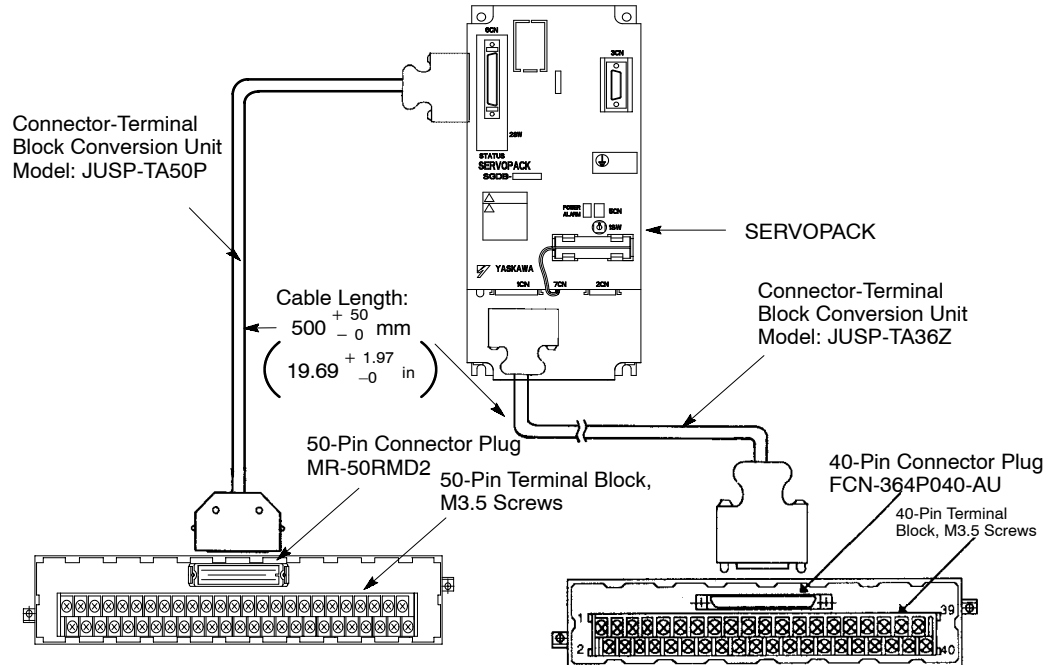

Figure 6.8 Connector-Terminal Block Conversion Unit Connected to SERVOPACK

■ 1CN Terminal Block Pin Numbers and Signal Names

The 1CN terminal block pin numbers and their corresponding signal names are shown in the following table.

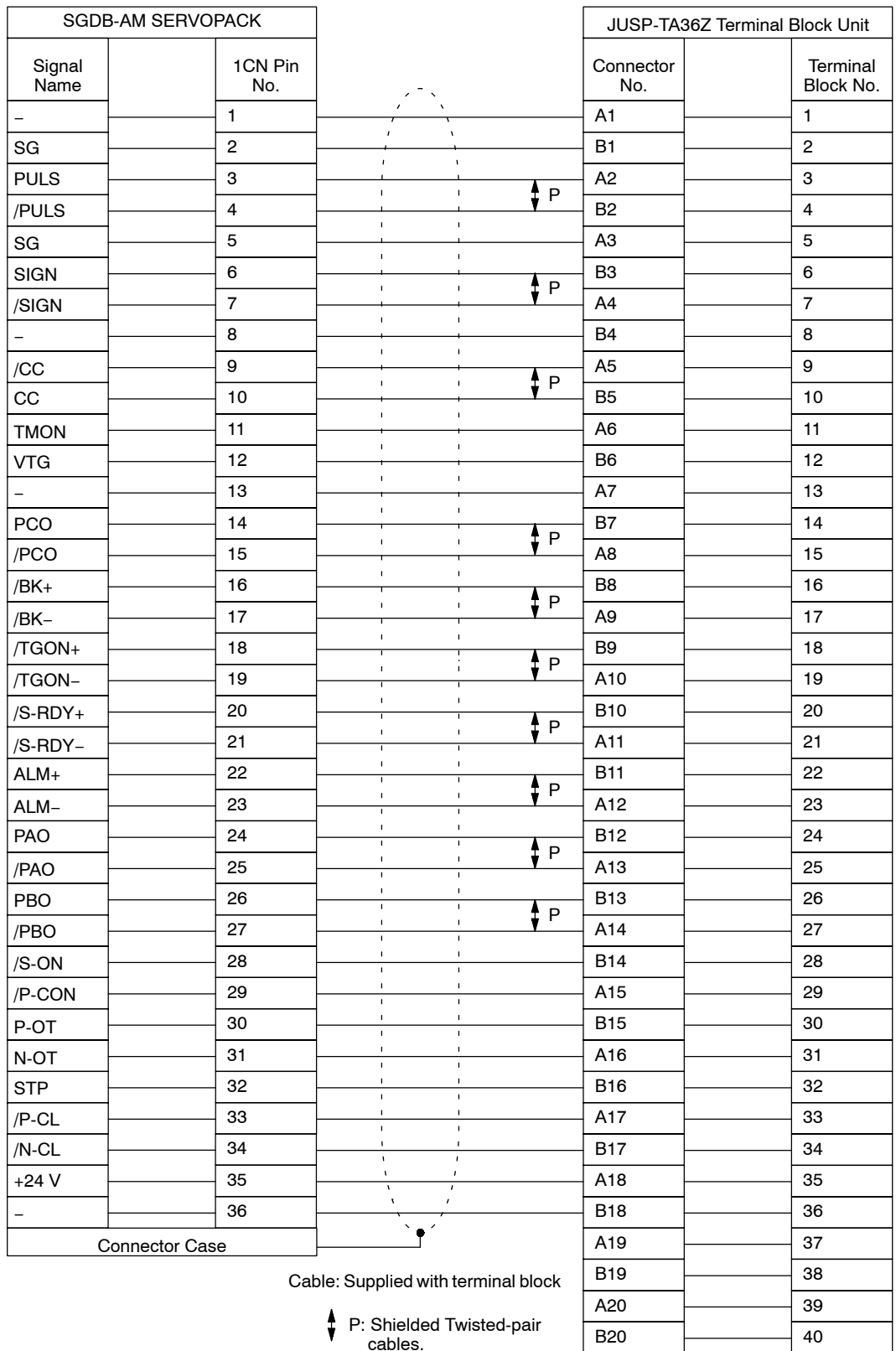

Figure 6.9 1CN Terminal Block Pin Numbers and Signal Names

6

■ 6CN Terminal Block Pin Numbers and Signal Names

The 6CN signal names differ according to the setting of Cn-27.

The 6CN terminal block pin numbers and their corresponding signal names when Cn-27 = 0 are shown in the following table.

(When station number command method is used.)

SGDB-AM SERVOPACK			JUSP-TA50P Terminal Block Unit		
Signal Name		6CN Pin No.		Connector No.	Terminal Block No.
0V1		1		A1	1
/AUT-LT		2		B1	2
/MAN-LT		3		A2	3
/POS1		4		B2	4
/POS2		5		A3	5
/AL0		6		B3	6
/AL1		7		A4	7
/AL2		8		B4	8
/AL3		9		A5	9
-		10		B5	10
-		11		A6	11
-		12		B6	12
/ZRN		13		A7	13
/MAN		14		B7	14
/PULS		15		A8	15
/MCW		16		B8	16
/MCCW		17		A9	17
/RST		18		B9	18
/SP2ND		19		A10	19
/SP3RD		20		B10	20
/LPG		21		A11	21
/AST		22		B11	22
/ALMRST		23		A12	23
STOP		24		B12	24
+24VI		25		A13	25
0V2		26		B13	26
/ERR		27		A14	27
/P0		28		B14	28
/P1		29		A15	29
/P2		30		B15	30
/P3		31		A16	31
/P4		32		B16	32
/CD0		33		A17	33
/CD1		34		B17	34
/CD2		35		A18	35
/CD3		36		B18	36
/CD4		37		A19	37
/CD5		38		B19	38
/CD6		39		A20	39
/CD7		40		B20	40
/CD8		41		A21	41
/CD9		42		B21	42
/CD10		43		A22	43
/CD11		44		B22	44
/DR0		45		A23	45
/DR1		46		B23	46
/PS0		47		A24	47
/PS1		48		B24	48
+24V2		49		A25	49
-		50		B25	50
Connector Case					

Cable: Supplied with terminal block

Figure 6.10 6CN Terminal Block Pin Numbers and Signal Names when Cn-27 = 0

The 6CN terminal block pin numbers and their corresponding signal names when Cn-27=1 are shown in the following table.

(When digital switch command method is used.)

SGDB-AM SERVOPACK			JUSP-TA50P Terminal Block Unit		
Signal Name		6CN Pin No.	Connector No.		Terminal Block No.
0V1		1	A1		1
/AUT-LT		2	B1		2
/MAN-LT		3	A2		3
/POS1		4	B2		4
/POS2		5	A3		5
/AL0		6	B3		6
/AL1		7	A4		7
/AL2		8	B4		8
/AL3		9	A5		9
-		10	B5		10
-		11	A6		11
-		12	B6		12
/ZRN		13	A7		13
/MAN		14	B7		14
/PULS		15	A8		15
/MCW		16	B8		16
/MCCW		17	A9		17
/RST		18	B9		18
/SP2ND		19	A10		19
/SP3RD		20	B10		20
/LPG		21	A11		21
/AST		22	B11		22
/ALMRST		23	A12		23
STOP		24	B12		24
+24V1		25	A13		25
0V2		26	B13		26
/ERR		27	A14		27
/DSO0		28	B14		28
/DSO1		29	A15		29
/DSO2		30	B15		30
/DSO3		31	A16		31
/DSO4		32	B16		32
/DSI10		33	A17		33
/DSI11		34	B17		34
/DSI12		35	A18		35
/DSI13		36	B18		36
/DSI14		37	A19		37
/DSI15		38	B19		38
/DSI16		39	A20		39
/DSI17		40	B20		40
/DSI20		41	A21		41
/DSI21		42	B21		42
/DSI22		43	A22		43
/DSI23		44	B22		44
/DSI24		45	A23		45
/DSI25		46	B23		46
/DSI26		47	A24		47
/DSI27		48	B24		48
+24V2		49	A25		49
-		50	B25		50

Cable: Supplied with terminal block

Figure 6.11 6CN Terminal Block Pin Numbers and Signal Names when Cn-27=1

The 6CN terminal block pin numbers and their corresponding signal names when Cn-27=4 are shown in the following table.

(When command table method is used.)

SGDB-AM SERVOPACK			JUSP-TA50P Terminal Block Unit		
Signal Name		6CN Pin No.		Connector No.	Terminal Block No.
0V1		1		A1	1
/AUT-LT		2		B1	2
/MAN-LT		3		A2	3
/POS1		4		B2	4
/POS2		5		A3	5
/AL0		6		B3	6
/AL1		7		A4	7
/AL2		8		B4	8
/AL3		9		A5	9
-		10		B5	10
-		11		A6	11
-		12		B6	12
/ZRN		13		A7	13
/MAN		14		B7	14
/PULS		15		A8	15
/MCW		16		B8	16
/MCCW		17		A9	17
/RST		18		B9	18
/SP2ND		19		A10	19
/SP3RD		20		B10	20
/LPG		21		A11	21
/AST		22		B11	22
/ALMRST		23		A12	23
STOP		24		B12	24
+24VI		25		A13	25
0V2		26		B13	26
/ERR		27		A14	27
/P0		28		B14	28
/P1		29		A15	29
/P2		30		B15	30
/P3		31		A16	31
/P4		32		B16	32
/CD0		33		A17	33
/CD1		34		B17	34
/CD2		35		A18	35
/CD3		36		B18	36
/CD4		37		A19	37
/CD5		38		B19	38
/CD6		39		A20	39
/CD7		40		B20	40
/CD8		41		A21	41
-		42		B21	42
-		43		A22	43
-		44		B22	44
-		45		A23	45
-		46		B23	46
/PS0		47		A24	47
/PS1		48		B24	48
+24V2		49		A25	49
-		50		B25	50

Cable: Supplied with terminal block

Figure 6.12 6CN Terminal Block Pin Numbers and Signal Names when Cn-27 = 4

6.6.10 Cable with 1CN Connector and One End without Connector

This cable has no connector at the host controller end. The loose wires have attached labels that indicate the terminal numbers.

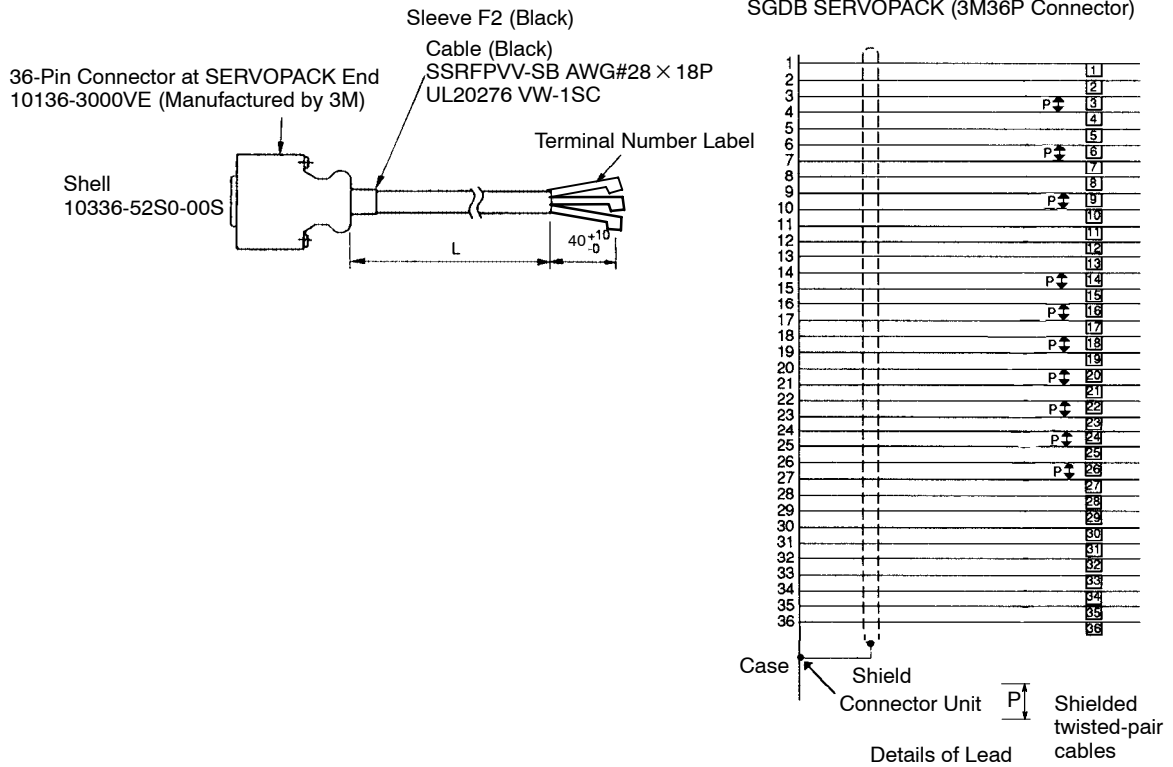

Cable Length

Cable Model	L in mm
JZSP-VB114-01	1000 ^{+ 30} ₋₃₀
JZSP-VB114-02	2000 ^{+ 50} ₋₅₀
JZSP-VB114-03	3000 ^{+ 50} ₋₅₀
JZSP-VB114-05	5000 ^{+ 50} ₋₅₀

6.6.11 Cable with 6CN Connector and One End without Connector

This cable has no connector at the host controller end. The loose wires have attached labels that indicate the terminal numbers.

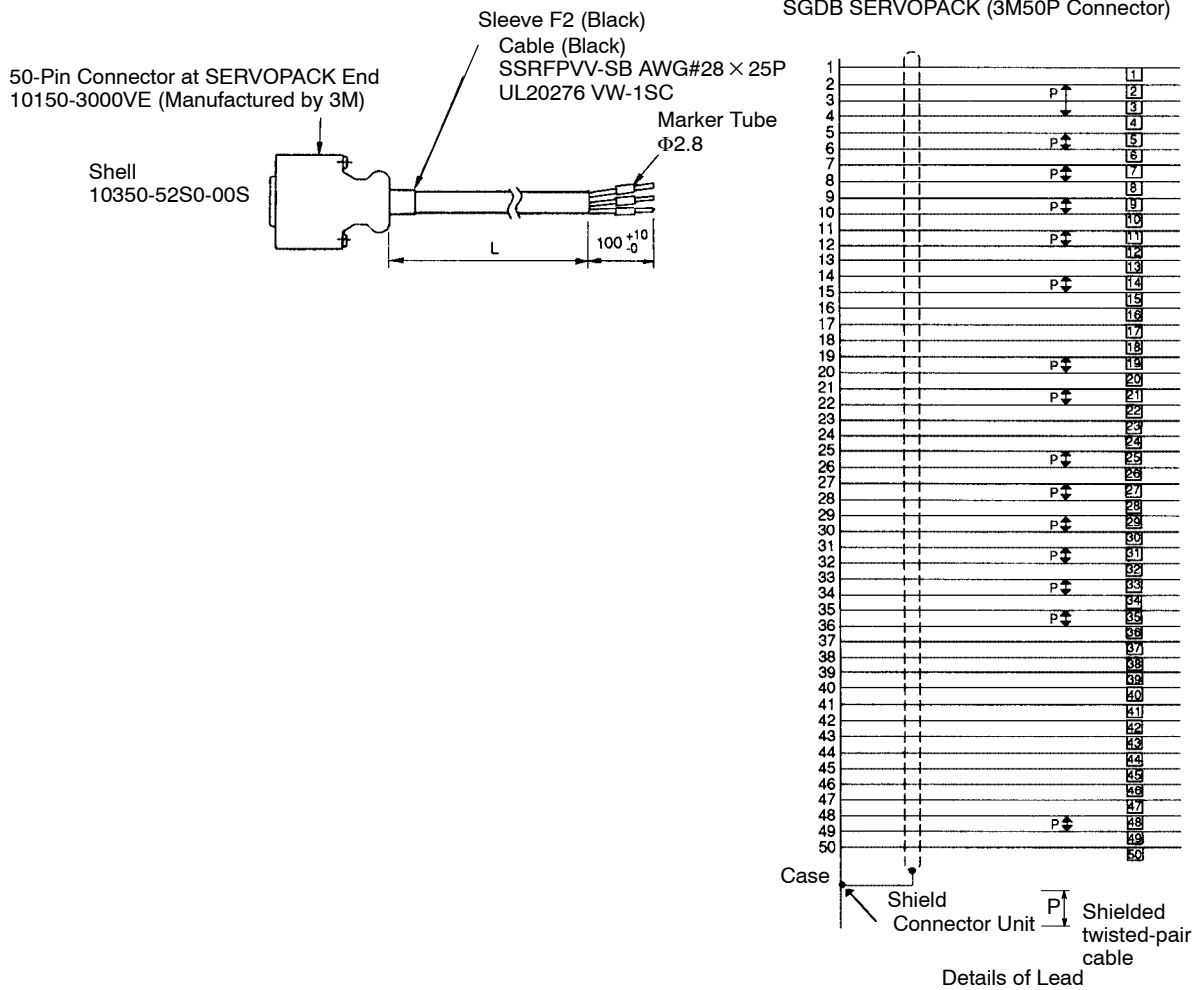

Cable Length

Cable Model	L in mm
JZSP-CKI01-1	1000 ⁺³⁰ ₀
JZSP-CKI01-2	2000 ⁺⁵⁰ ₀
JZSP-CKI01-3	3000 ⁺⁵⁰ ₀

6.6.12 Circuit Breaker

Use a molded-case circuit breaker (MCCB) to protect the power lines. The customer should purchase MCCB of appropriate capacity.

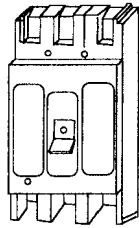

6.6.13 Noise Filter

A noise filter is installed to prevent external noise entering through the power supply line. Select a noise filter from the following three models according to the SERVOPACK capacity.

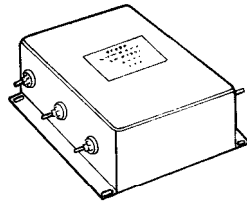

■ Dimensional Diagram

- LF-300 (Three-phase 200 VAC Class)

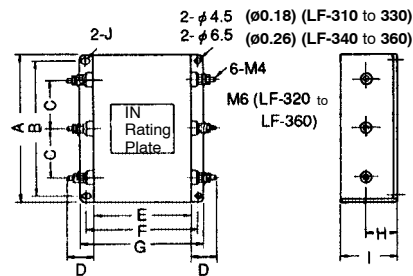

Unit: mm (in)

Part Name	A	B	C	D	E	F	G	H	I	J
LF-310	180 (7.09)	170 (6.69)	60 (2.36)	25 (0.98)	120 (4.72)	135 (5.31)	150 (5.91)	35 (1.38)	65 (2.56)	4.5(0.18) ×7
LF-315	180 (7.09)	170 (6.69)	60 (2.36)	25 (0.98)	120 (4.72)	135 (5.31)	150 (5.91)	35 (1.38)	65 (2.56)	4.5(0.18) ×7
LF-320	180 (7.09)	170 (6.69)	60 (2.36)	29 (1.14)	120 (4.72)	135 (5.31)	150 (5.91)	35 (1.38)	65 (2.56)	4.5(0.18) ×7

Part Name	A	B	C	D	E	F	G	H	I	J
LF-330	180 (7.09)	170 (6.69)	60 (2.36)	29 (1.14)	120 (4.72)	135 (5.31)	150 (5.91)	35 (1.38)	65 (2.56)	4.5(0.18) ×7
LF-340	180 (7.09)	160 (6.30)	50 (1.97)	30 (1.18)	200 (7.87)	220 (8.66)	240 (9.45)	40 (1.57)	80 (3.15)	6.5(0.26) ×9
LF-350	180 (7.09)	160 (6.30)	50 (1.97)	30 (1.18)	200 (7.87)	220 (8.66)	240 (9.45)	40 (1.57)	80 (3.15)	6.5(0.26) ×9
LF-360	200 (7.87)	180 (7.09)	60 (2.36)	30 (1.18)	300 (11.81)	320 (12.60)	340 (13.39)	40 (1.57)	100 (3.93)	6.5(0.26) ×9

● LF-K (Three-phase 200 VAC Class)

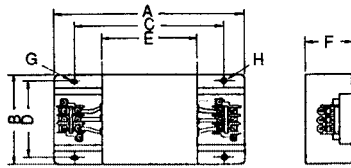

Unit: mm (in)

Parts Name	Terminal Block	A	B	C	D	E	F	G	H
LF-380K	TE-K22 M6	670 (26.38)	400 (15.75)	560 (22.05)	380 (14.96)	500 (19.69)	170 (6.69)	9×Ø6.5 (0.26)	Ø6.5 (0.26)

● FN258-100 (Three-phase 200 VAC Class)

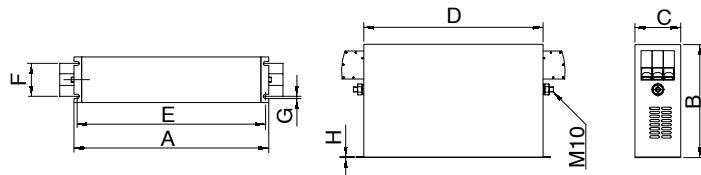

Unit: mm (in)

Parts Name	A	B	C	D	E	F	G	H
FN-258-100	379 ± 1.5 (14.92 ± 0.059)	220 (8.66)	90 ± 8 (3.54 ± 0.31)	350 ± 1.2 (13.78 ± 0.047)	364 (14.33)	65 (2.56)	6.5 (0.26)	1.5 (0.059)

6.6.14 Magnetic Contactor

The magnetic contactor turns ON and OFF the SERVOPACK power supply. The magnetic contactor must be used with a surge suppressor.

Select an appropriate magnetic contactor according to the SGDB SERVOPACK capacity. For multiple servo systems, select a magnetic contactor that meets the total capacity.

The outside dimensions and terminal symbols of magnetic contactors are shown in the following table.

Table 6.27 Outside Dimensions and Terminal Symbols of Magnetic Contactor

Unit: mm (in)

Model *	Outside Dimensions	Mounting Holes	Terminal Symbols																											
HI-15J HI-18J	<p>45.5 (1.79) 8.2 (0.32) 15.3 (0.60) 3 (0.12) 1 (0.04) 29 (1.14) 50 (1.97) 85 (3.35) 51 (2.01) 9.6 (0.38) 8.2 (0.32) 11.3 (0.44) 11.3 (0.44) 10.8 (0.43) M3.5 Coil Terminals M3.5 Auxiliary Contact Terminals M4 Main Contact Terminals</p>	<p>91 (3.58) 65 (2.56) 39 (1.54) 4.5 (1.18) 9 (0.35) 54 (2.13) 76 (2.99) 35 (1.38) 70 (2.76) 75 (2.95) Approx. Mass 0.38 kg (0.84 lb)</p>	<p>5.2 (0.20) 35 (1.38) 5 (1.20) 2 × M4 Mounting Holes</p>	<table border="1"> <thead> <tr> <th>Auxiliary contact</th> <th>Structure</th> </tr> </thead> <tbody> <tr> <td>1NO</td> <td>a[A1] — o — A2b</td> </tr> <tr> <td>1NC</td> <td> <table border="1"> <tr> <td>R</td><td>1</td> <td>S</td><td>3</td> <td>T</td><td>5</td> <td>1</td><td>2</td> <td>3</td><td>13</td> </tr> <tr> <td>U</td><td>2</td> <td>V</td><td>4</td> <td>W</td><td>6</td> <td>2</td><td>22</td> <td>4</td><td>14</td> </tr> </table> </td> </tr> </tbody> </table>	Auxiliary contact	Structure	1NO	a[A1] — o — A2b	1NC	<table border="1"> <tr> <td>R</td><td>1</td> <td>S</td><td>3</td> <td>T</td><td>5</td> <td>1</td><td>2</td> <td>3</td><td>13</td> </tr> <tr> <td>U</td><td>2</td> <td>V</td><td>4</td> <td>W</td><td>6</td> <td>2</td><td>22</td> <td>4</td><td>14</td> </tr> </table>	R	1	S	3	T	5	1	2	3	13	U	2	V	4	W	6	2	22	4	14
Auxiliary contact	Structure																													
1NO	a[A1] — o — A2b																													
1NC	<table border="1"> <tr> <td>R</td><td>1</td> <td>S</td><td>3</td> <td>T</td><td>5</td> <td>1</td><td>2</td> <td>3</td><td>13</td> </tr> <tr> <td>U</td><td>2</td> <td>V</td><td>4</td> <td>W</td><td>6</td> <td>2</td><td>22</td> <td>4</td><td>14</td> </tr> </table>	R	1	S	3	T	5	1	2	3	13	U	2	V	4	W	6	2	22	4	14									
R	1	S	3	T	5	1	2	3	13																					
U	2	V	4	W	6	2	22	4	14																					
HI-20J	<p>45.5 (1.79) 8.2 (0.32) 15.3 (0.60) 7 (0.28) 5 (0.20) 29 (1.14) 50 (1.97) 85 (3.35) 51 (2.01) 9.6 (0.38) 8.2 (0.32) 11.3 (0.44) 11.3 (0.44) 10.8 (0.43) M3.5 Coil Terminals M3.5 Auxiliary Contact Terminals M4 Main Contact Terminals</p>	<p>91 (3.58) 65 (2.56) 39 (1.54) 4.5 (1.18) 9 (0.35) 54 (2.13) 76 (2.99) 35 (1.38) 70 (2.76) 75 (2.95) Approx. Mass 0.38 kg (0.84 lb)</p>	<p>5.2 (0.20) 35 (1.38) 5 (1.20) 2 × M4 Mounting Holes</p>	<table border="1"> <thead> <tr> <th>Auxiliary contact</th> <th>Structure</th> </tr> </thead> <tbody> <tr> <td>1NO</td> <td>a[A1] — o — A2b</td> </tr> <tr> <td>1NC</td> <td> <table border="1"> <tr> <td>R</td><td>1</td> <td>S</td><td>3</td> <td>T</td><td>5</td> <td>5</td><td>4</td> <td>7</td><td>23</td> </tr> <tr> <td>U</td><td>2</td> <td>V</td><td>4</td> <td>W</td><td>6</td> <td>6</td><td>42</td> <td>8</td><td>24</td> </tr> </table> </td> </tr> </tbody> </table>	Auxiliary contact	Structure	1NO	a[A1] — o — A2b	1NC	<table border="1"> <tr> <td>R</td><td>1</td> <td>S</td><td>3</td> <td>T</td><td>5</td> <td>5</td><td>4</td> <td>7</td><td>23</td> </tr> <tr> <td>U</td><td>2</td> <td>V</td><td>4</td> <td>W</td><td>6</td> <td>6</td><td>42</td> <td>8</td><td>24</td> </tr> </table>	R	1	S	3	T	5	5	4	7	23	U	2	V	4	W	6	6	42	8	24
Auxiliary contact	Structure																													
1NO	a[A1] — o — A2b																													
1NC	<table border="1"> <tr> <td>R</td><td>1</td> <td>S</td><td>3</td> <td>T</td><td>5</td> <td>5</td><td>4</td> <td>7</td><td>23</td> </tr> <tr> <td>U</td><td>2</td> <td>V</td><td>4</td> <td>W</td><td>6</td> <td>6</td><td>42</td> <td>8</td><td>24</td> </tr> </table>	R	1	S	3	T	5	5	4	7	23	U	2	V	4	W	6	6	42	8	24									
R	1	S	3	T	5	5	4	7	23																					
U	2	V	4	W	6	6	42	8	24																					

6.6.14 Magnetic Contactor

Model *	Outside Dimensions	Mounting Holes	Terminal Symbols				
HI-25J HI-35J	<p>Approx. Mass 0.68 kg (1.50 lb)</p>	<p>2 x M4 Mounting Holes</p>	<table border="1"> <thead> <tr> <th data-bbox="1091 400 1177 431">Auxiliary contact</th> <th data-bbox="1177 400 1457 431">Structure</th> </tr> </thead> <tbody> <tr> <td data-bbox="1091 495 1177 612">1NO 1NC</td> <td data-bbox="1177 431 1457 612"> </td> </tr> </tbody> </table>	Auxiliary contact	Structure	1NO 1NC	
Auxiliary contact	Structure						
1NO 1NC							
HI-50J HI-65J	<p>Approx. Mass 1.1 kg (2.43 lb)</p>	<p>2 x M4 Mounting Holes (Recommended)</p>	<table border="1"> <thead> <tr> <th data-bbox="1091 863 1177 895">Auxiliary contact</th> <th data-bbox="1177 863 1457 895">Structure</th> </tr> </thead> <tbody> <tr> <td data-bbox="1091 959 1177 1076">1NO 1NC</td> <td data-bbox="1177 895 1457 1076"> </td> </tr> </tbody> </table>	Auxiliary contact	Structure	1NO 1NC	
Auxiliary contact	Structure						
1NO 1NC							

6

6.6.15 Surge Suppressor

Manufactured by Yaskawa Controls Co., Ltd.

The surge suppressor absorbs voltage surges generated when the magnetic coil is off. This prevents faulty operation in or damage to electronic parts near the magnetic contactors or switches.

Recommended surge suppressors for the HI-□J series of magnetic contactors are listed here.

■ Surge Suppressor Types and Ratings

Model	Absorption	Rated Insulation Voltage	Applicable Magnetic-Coil Voltage Range						Applicable Magnetic Contactor
			AC 50/60 Hz						
			50 V	110 V	127 V	240 V	380 V	440 V	
TU-25C240	CR	300 VAC	████████████████████						HI-15J, HI-18J, HI-20J
TU-65C240	CR	300 VAC	████████████████████						HI-25J, HI-35J, HI-50J, HI-65J

Note: ██████████ : Indicates the applicable voltage range for the magnetic coil.

■ Dimensional Drawings

- TU-25C240

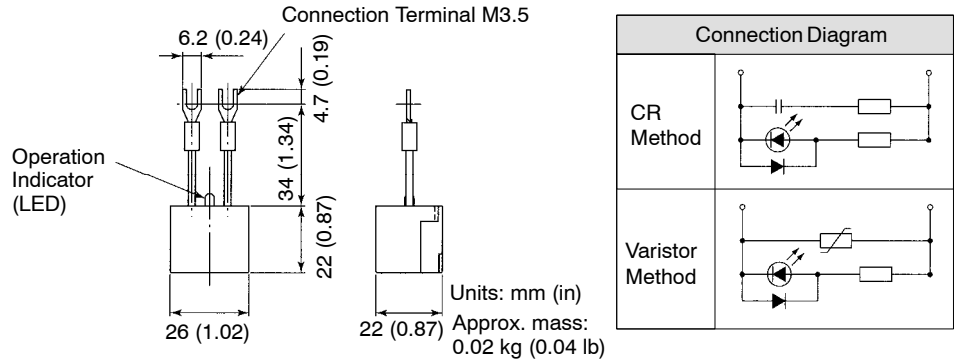

- TU-65C240

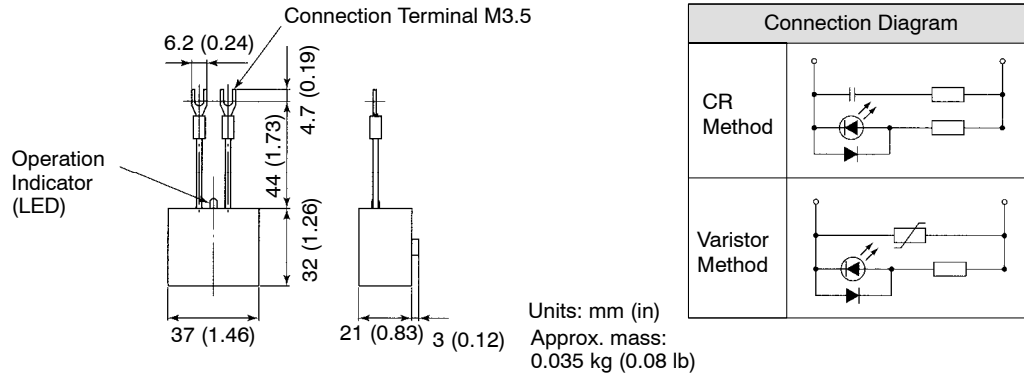

6.6.16 Regenerative Resistor Unit

For SERVOPACKs for use with motors with 3.2 kW or more (SGDB-50AM/60AM/75AM/1AAM/1EAM), externally attach a regenerative resistor to the SERVOPACK. This resistor is used for dissipating regenerative energy.

Use one of the following regenerative resistor units according to the SERVOPACK model:

SERVOPACK Model SGDB-	Regenerative Resistor Unit Model
50AM	JUSP-RA04
60AM	
75AM	JUSP-RA05
1AAM	
1EAM	

■ Dimensional Drawings

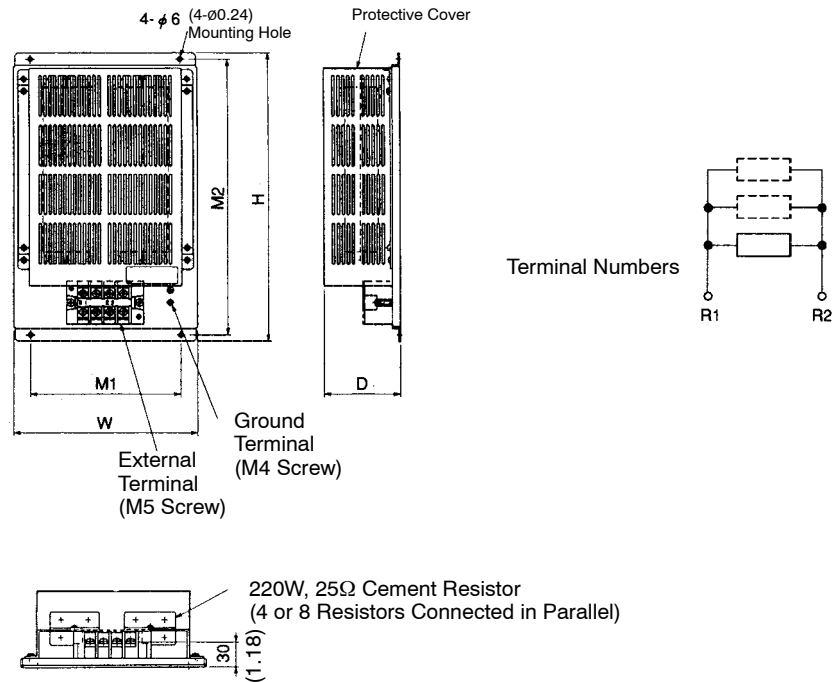

Unit: mm (in)

Model	W	H	D	M1	M2	Approx. mass
JUSP-RA04	220 (8.66)	350 (13.78)	92 (3.62)	180 (7.09)	335 (13.19)	4 kg (8.82 lb)
JUSP-RA05	300 (11.81)	350 (13.78)	95 (3.74)	250 (9.84)	335 (13.19)	7 kg (15.43 lb)

6.6.17 External Position Indicator (Model MCIF-L8)

■ Specifications

Model	MCIF-L8
Item	
Power Supply	5 VDC, 1A
Power Fluctuation Range	4.75 to 5.25 V
Operating Temperature	0 to +55°C
Storage Temperature	-20 to +80°C
Operating and Storage Humidity	90% or less
Vibration/Shock Resistance	Vibration resistance: 4.9 m/s ² (0.5 G)(10 to 55 Hz) Shock resistance: 19.6 m/s ² (2 G)

Model	MCIF-L8
No. of Displayed Digits	“-” (minus) sign and 8 digits
Connection Method	Connect to 3CN serial communications connector of SGDB-AM

■ **Circuit Block Diagram**

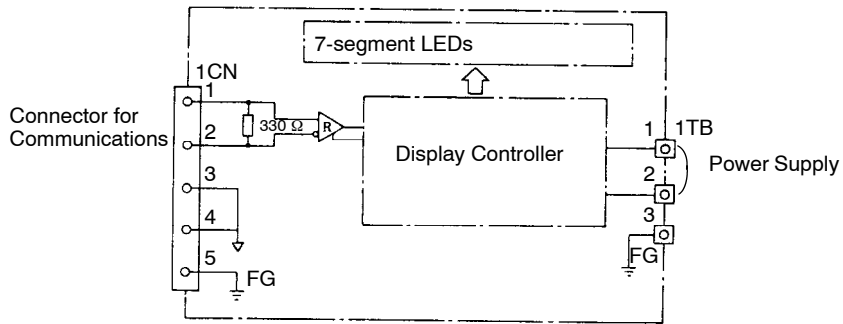

Connect to Power Supply

Model	ITB	1	2	3
MCIF-L8		+5 V	0	FG

Note: 1. 1CN pin nos. 7 and 8 are test pins and should not be connected to anything. Other pins are unused.

2. The RESET button on the front panel does not perform any function.

■ Dimensional Drawings

Model MCIF-L8

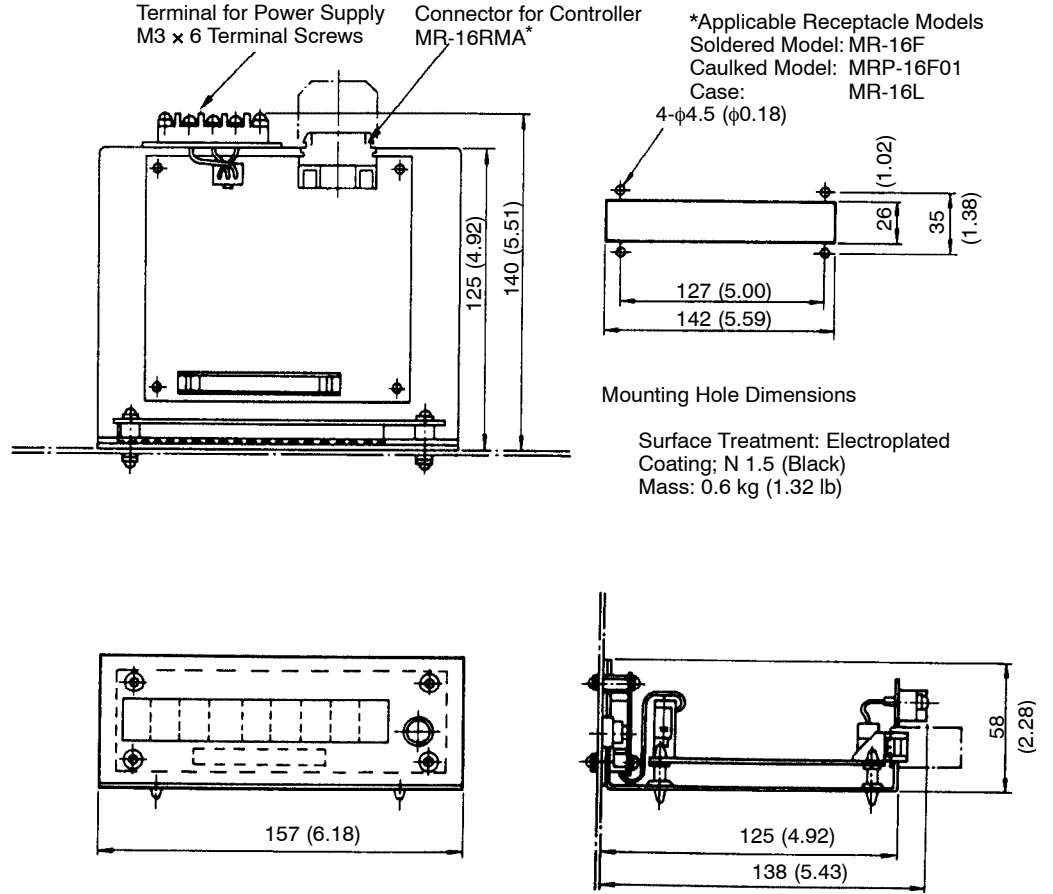

6.6.18 Digital Switch Unit (MCIF-D□□)

This Digital Switch Unit is intended for use with SGDB-□□AM. It cannot be used with SGDB-□□AMA.

■ Specifications

Model	MCIF-D86	MCIF-D66	MCIF-D44	MCIF-D80	MCIF-D60	MCIF-D40
Data Content	2-step (position command and speed command data)			1-step (position command data only)*		
Position Command Data	BCD 8 digits and sign	BCD 6 digits and sign	BCD 4 digits and sign	BCD 8 digits and sign	BCD 6 digits and sign	BCD 4 digits and sign
Speed Command Data	BCD 6 digits	BCD 6 digits	BCD 4 digits	None		

Model	MCIF-D86	MCIF-D66	MCIF-D44	MCIF-D80	MCIF-D60	MCIF-D40
Operating Temperature	0 to +55°C					
Storage Temperature	-20 to +80°C					
Vibration/Shock Resistance	Vibration resistance: 4.9 m/s ² (0.5 G)(10 to 55 Hz) Shock resistance: 19.6 m/s ² (2 G)					
Connection	Connect to 6CN connector of SGDB-AM.					

* 1-step units can be used for speed command data also. (Note, however, that this usage requires a different connector cable. The cable provided by Yaskawa cannot be used for speed command data.)

■ Circuit Diagram

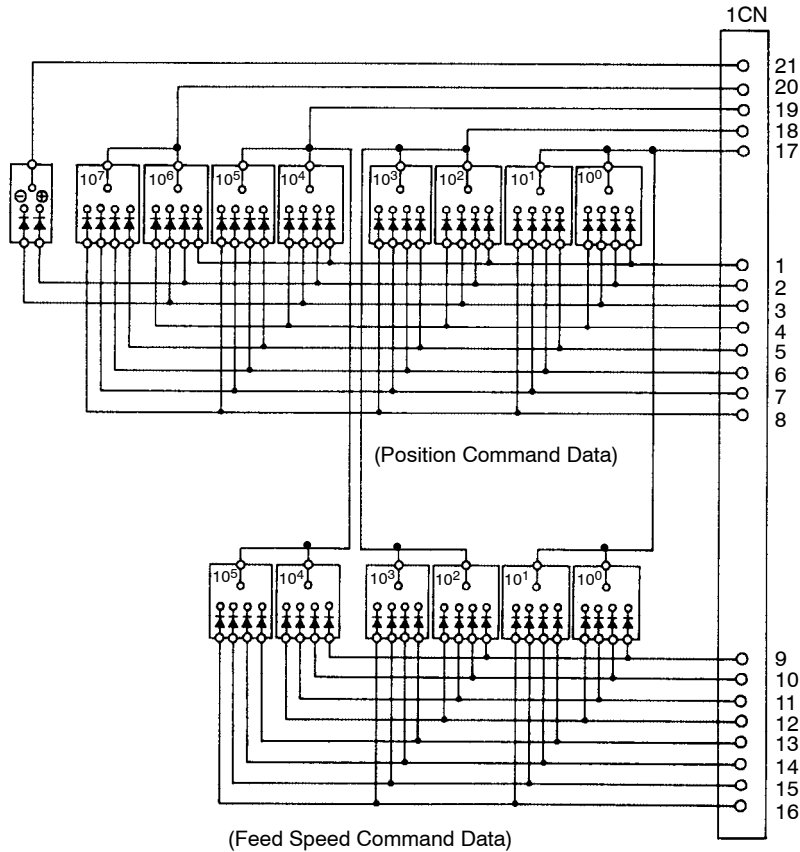

6

■ Dimensional Drawings

MCIF-D44, -D66, -D86 Models

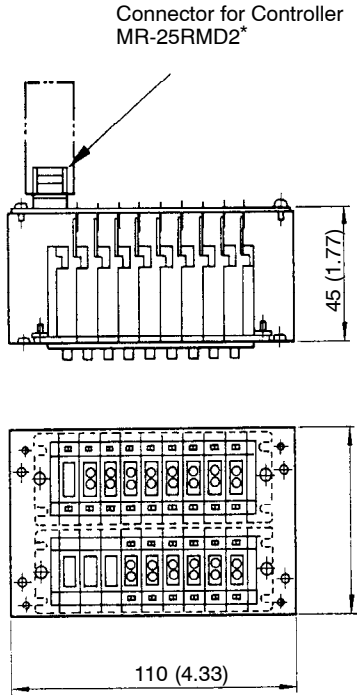

*Applicable Receptacle Models
Soldered Model: MR-25F
Caulked Model: MRP-25F01
Case: MR-25L

Surface Treatment: Electroplated Coating;
N 1.5 (Black)
Mass: 0.3 kg (0.66 lb)

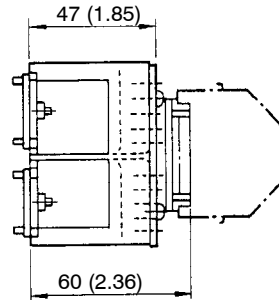

Unit: mm (in)

No. of Digits	Model	L
4	MCIF-D44	47.5 (1.87)
6	MCIF-D66	63.5 (2.50)
8	MCIF-D86	79.5 (3.13)

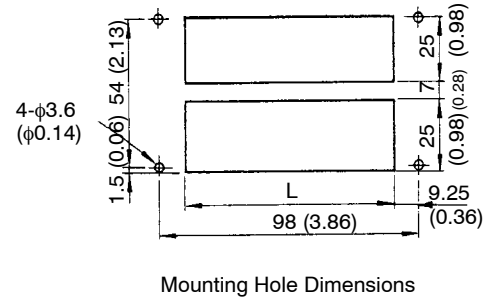

MCIF-D40, -D60, -D80 Models

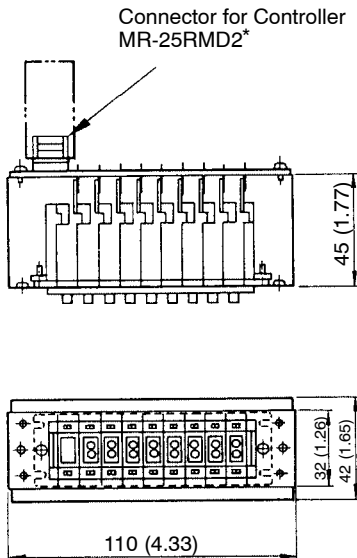

*Applicable Receptacle Models
Soldered Model: MR-25F
Caulked Model: MRP-25F01
Case: MR-25L

Surface Treatment: Electroplated
Coating; N 1.5 (Black)
Mass: 0.2 kg (0.44 lb)

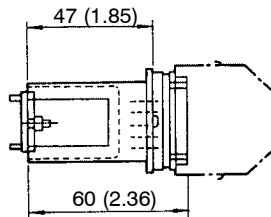

Unit: mm (in)

No. of Digits	Model	L
4	MCIF-D40	47.5 (1.87)
6	MCIF-D60	63.5 (2.50)
8	MCIF-D80	79.5 (3.13)

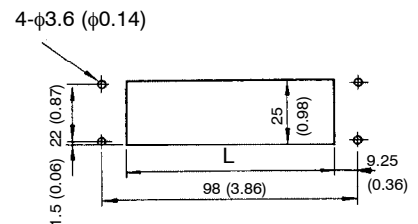

6.6.19 Contact Input Unit (MCIF-R86)

The Contact Input Unit is intended for use with SGDB-□□AM. It cannot be used with SGDB-□□AMA.

■ Specifications

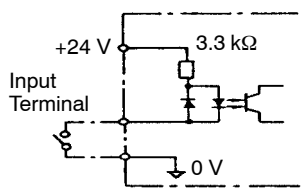
Model Item	MCIF-R86
Data Content	Position command (sign signal and 8-digit BCD signal), speed command (6-digit BCD signal)
Operating Temperature	0 to +55°C
Storage Temperature	-20 to +80°C
Operating and Storage Humidity	99% or less
Vibration/Shock Resistance	Vibration resistance: 4.9 m/s ² (0.5 G)(10 to 55 Hz) Shock resistance: 19.6 m/s ² (2 G)
Input Conditions	DC 24 V power supply, photocoupler (drive current 7 mA), dry contact and transistor open collector input, position data 1CN connector, speed data 2CN connector. <div style="text-align: right;">  </div>
Connection	Connect 3CN connector and 6CN connector of SGDB-AM.

6

■ Dimensional Drawings

MCIF-R86 Model

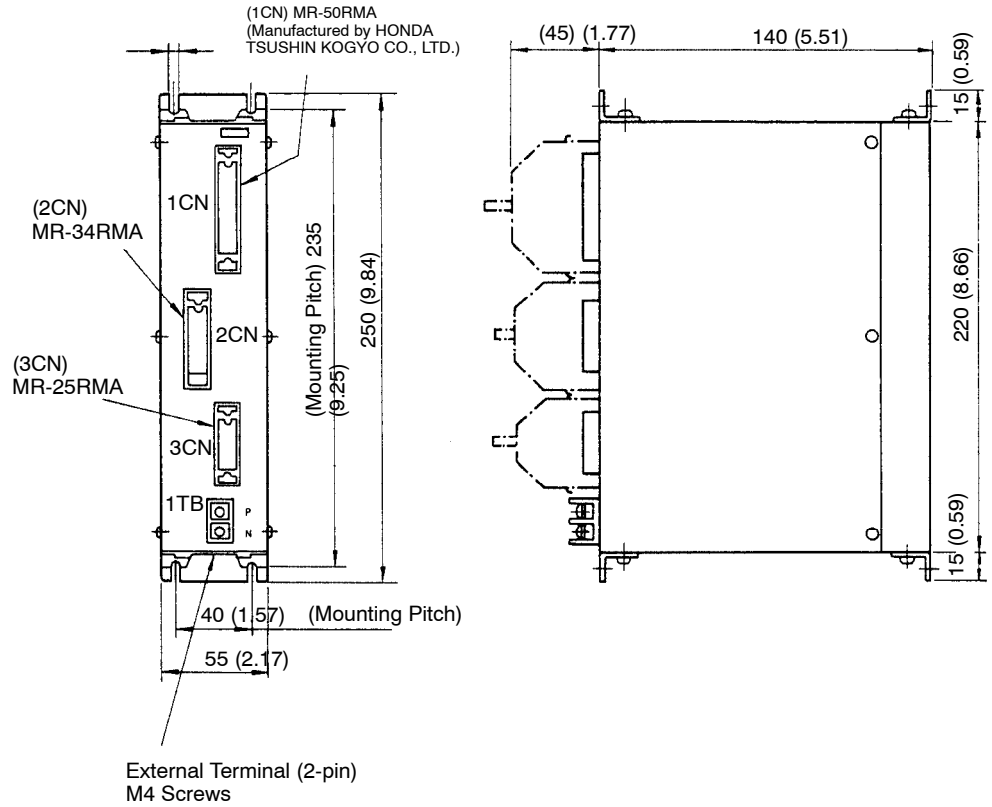

Accessories
1CN Connector (for Cable) Hood: MR-50L Housing: MR-50F (Manufactured by HONDA TSUSHIN KOGYO CO., LTD.)
2CN Connector (for Cable) Hood: MR-34L Housing: MR-34F (Manufactured by HONDA TSUSHIN KOGYO CO., LTD.)
3CN Connector (for Cable) Hood: MR-25L Housing: MR-25F (Manufactured by HONDA TSUSHIN KOGYO CO., LTD.)

■ Connection Diagram

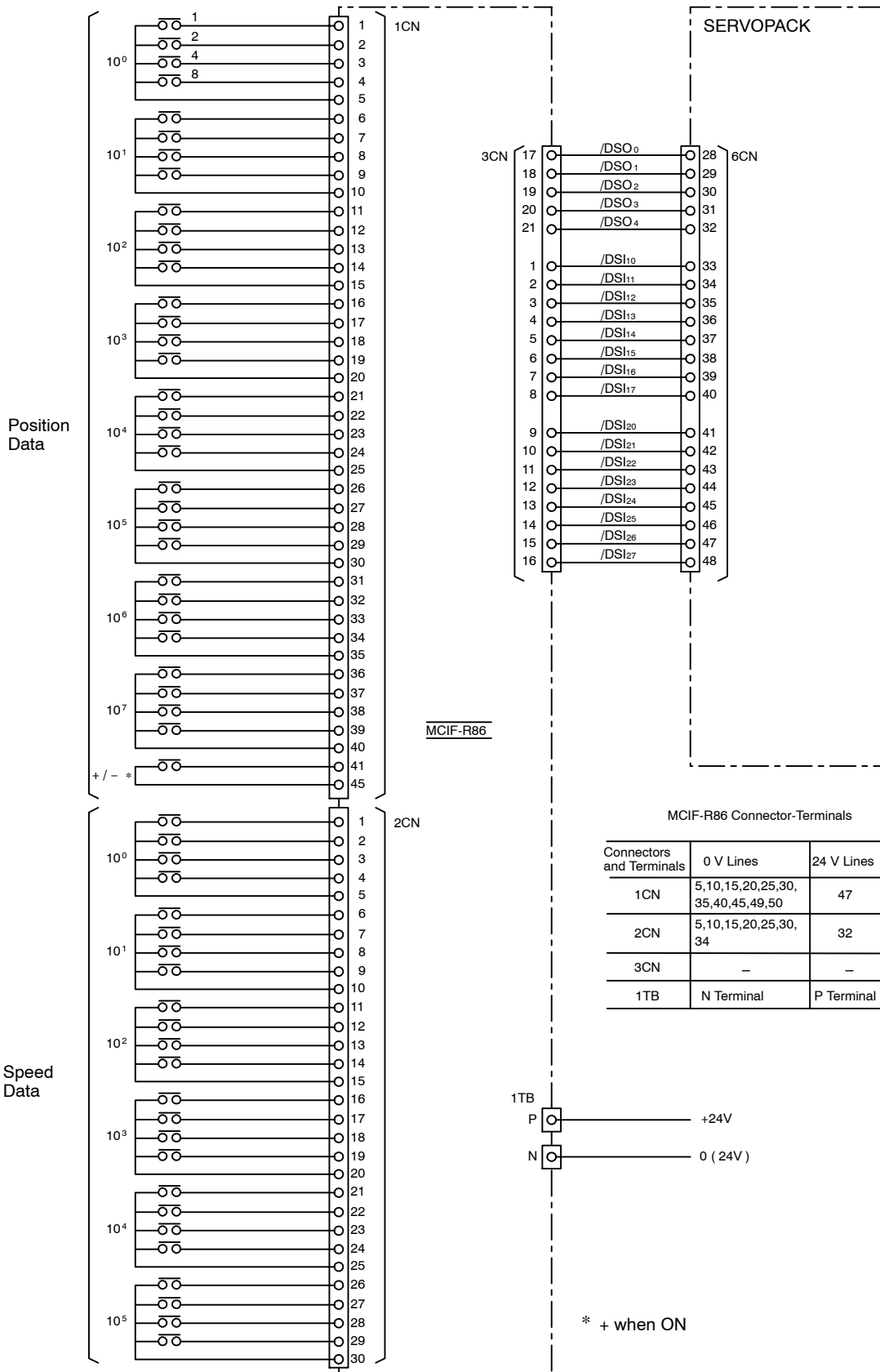

MCIF-R86 Connector-Terminals

Connectors and Terminals	0 V Lines	24 V Lines	Unused Pins
1CN	5,10,15,20,25,30,35,40,45,49,50	47	46,48
2CN	5,10,15,20,25,30,34	32	31,33
3CN	-	-	22,23,24,25
1TB	N Terminal	P Terminal	-

* + when ON

6

6.6.20 Manual Pulse Generator (PRET-2C3T/100-M1)

■ Specifications

Model	PRET-2C3T/100-M1
Item	
Power Supply	5 VDC \pm 10% 150 mA
Output Waveform, Output Type	Short wave, line driver output
Output Pulse Number, Output Signal	100 pulses/revolution, 90° phase difference 2 signal (phase A, phase B)
Operating Temperature	0 to +50°C
Storage Temperature	-30 to +70°C
Operating and Storage Humidity	20% to 80%RH
Connection	Connect to 1CN connector of SGDB-AM.

■ Output Terminal Arrangement

Symbol	Function
1	+V (5 VDC)
2	V (0 V)
3	SIG. A
4	SIG. \bar{A}
5	SIG. B
6	SIG. \bar{B}

Note: When connecting to the SERVOPACK, connect SIG.A and SIG. \bar{A} as shown below - the reverse of the logical sequence shown in the table at left.

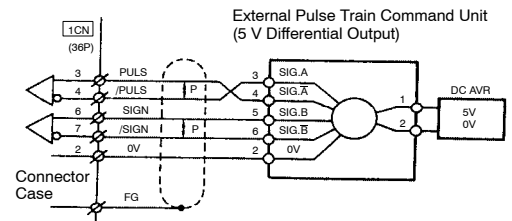

■ Dimensional Drawing

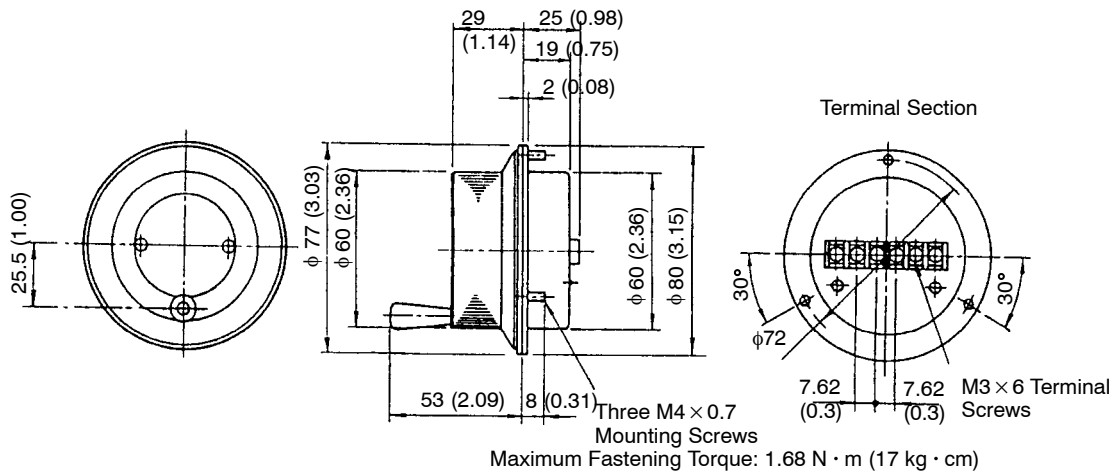

Panel Cut Dimensions

- Note: 1. Refer to the figure at right when performing the panel cut.
 2. The dial is made from resin.
 3. The receiver IC is equivalent to AM26LS32C or SN75175.

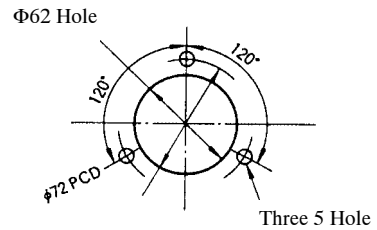

6.6.21 Cables for Connecting Personal Computer and SERVOPACK

Special cables for connecting a personal computer to a SERVOPACK. Using these cables allows monitoring and setting of parameters with a personal computer. Personal computer software is available for these communications. Ask your Yaskawa representative for details. Operate the software as described in the manual supplied.

Cable for PC/AT-Compatible Computers (model DE9408565)

- Cable Form

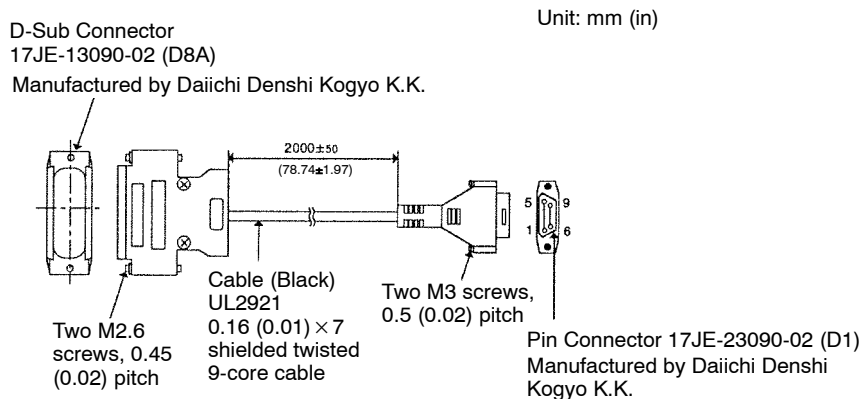

- Connection Circuit

Personal Computer Side
(D-Sub 9-pin)

SERVOPACK Side (D-Sub
9-pin)

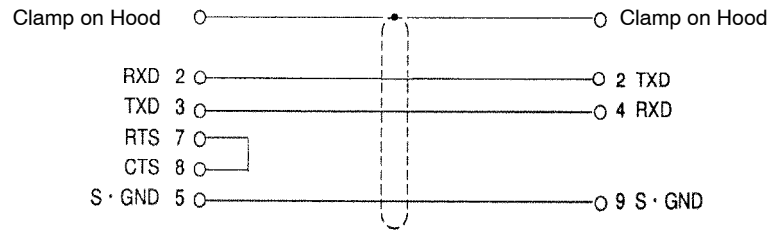

7

Inspection, Maintenance, and Troubleshooting

This chapter describes the basic inspections and maintenance to be carried out by the customer.

In addition, troubleshooting procedures are described for problems which cause an alarm display and for problems which result in no alarm display.

7.1 Inspection and Maintenance	7 -2
7.1.1 Servomotor	7 -2
7.1.2 SERVOPACK	7 -3
7.1.3 Replacing Battery for Back-up	7 -4
7.2 Troubleshooting	7 -5
7.2.1 Troubleshooting Problems with Alarm Display ...	7 -5
7.2.2 Troubleshooting Problems with No Alarm Display	7 -34
7.2.3 Internal Connection Diagram and Instrument Connection Examples	7 -36

7.1 Inspection and Maintenance

This chapter describes the basic inspection and maintenance procedures for the Servomotor and SERVOPACK, as well as the method of replacing back-up batteries used for the absolute encoder and the built-in memory of the SERVOPACK.

7.1.1 Servomotor

For inspection and maintenance of servomotors, follow the simple, daily inspection procedures in the table below. The AC servomotors are brushless. Simple, daily inspection is sufficient. The inspection and maintenance frequencies in the table are only guidelines. Increase or decrease the frequency to suit the operating conditions and environment.

IMPORTANT

During inspection and maintenance, do not disassemble the servomotor. If disassembly of the servomotor is required, contact your Yaskawa representative.

Table 7.1 Servomotor Inspections

Item	Frequency	Procedure	Comments
Vibration and noise	Daily	Touch and listen.	Levels higher than normal?
Appearance	According to degree of contamination	Clean with cloth or compressed air.	
Insulation resistance measurement	Yearly	Disconnect SERVOPACK and test insulation resistance at 500 V. Must exceed 10 MΩ*.	Contact your Yaskawa representative if the insulation resistance is below 10 MΩ.
Replace oil seal	Every 5,000 hours	Remove servomotor from machine and replace oil seal.	Applies only to motors with oil seal.
Overhaul	Every 20,000 hours or 5 years	Contact your Yaskawa representative.	The customer should not disassemble and clean the servomotor.

* Measure across the servomotor FG and the phase-U, phase-V, or phase-W power lead.

7.1.2 SERVOPACK

For inspection and maintenance of the SERVOPACK, follow the inspection procedures in the table below at least once every year. The SERVOPACK contains highly reliable parts and daily inspection is not required. Carry out the inspections and maintenance in the table below once every year.

Table 7.2 SERVOPACK Inspections

Item	Frequency	Procedure	Remedy
Clean unit interior and circuit boards	Yearly	Check for dust, dirt, and oil on the surfaces.	Clean with cloth or compressed air.
Loose screws	Yearly	Check for loose terminal block and connector screws.	Tighten any loose screws.
Defective parts in unit or on circuit boards	Yearly	Check for discoloration, damage or discontinuities due to heating.	Contact your Yaskawa representative.

■ Part Replacement Schedule

The following parts are subject to mechanical wear or deterioration over time. To avoid failure, replace these parts at the frequency indicated.

If the SERVOPACK has been already overhauled at Yaskawa, its parameters are set back to the standard settings on shipment. Always check the parameters before operating the motor.

Table 7.3 Periodical Part Inspections

Part	Standard Replacement Period	Replacement Method
Cooling fan	4 to 5 years	Replace with new part.
Smoothing Capacitor	7 to 8 years	Test. Replace with new part if necessary.
Relays	–	Test. Replace if necessary.
Fuse	10 years	Replace with new part.
Aluminum Electrolytic Capacitor on Circuit Board	5 years	Test. Replace with new circuit board if necessary.

Operating Conditions

- Ambient Temperature: annual average 30°C
- Load Factor: 80% max.
- Operation Rate: 20 hours/day max.

7.1.3 Replacing Battery for Back-up

Battery replacement is only required for servo systems using a battery for back-up.

The battery model recommended below (purchased by the customer) is installed in the host controller to allow the back-up memory or the absolute encoder to store position data when the power is turned OFF.

Recommended Battery

Lithium Battery
 PMC ER6V for use with connector
 manufactured by Yaskawa Controls Co., Ltd.
 3.6 V, 2000 mAh
 Estimated Life: Approximately 10 years

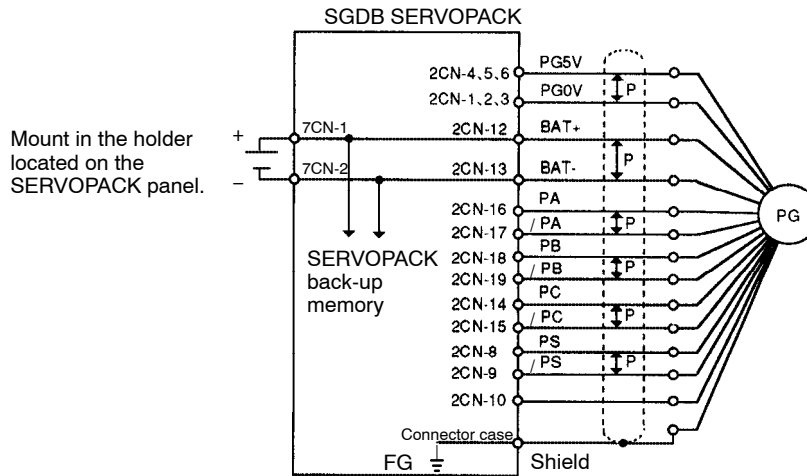
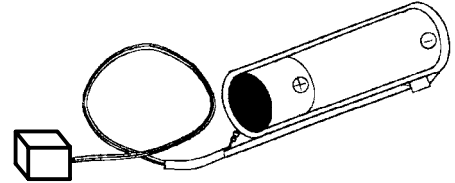

Figure 7.1 Connection Diagram of Back-up Battery

The SERVOPACK monitors the battery voltage. If this voltage drops, a low battery alarm will appear.

If a low battery alarm appears, replace the battery using the following procedure.

■ Battery Replacement Procedure

1. Turn ON the SERVOPACK.
2. Replace the battery in the SERVOPACK.

7.2 Troubleshooting

This section describes causes and remedies for problems which cause an alarm display and for problems which result in no alarm display.

7.2.1 Troubleshooting Problems with Alarm Display

If the servo drive develops a problem, an alarm display “A.□□” or “CPF□□” will appear in the Digital Operator. Note, however, that “A.99” is not an alarm. The alarm displays and their correct remedies are listed below.

Contact your Yaskawa representative if the problem cannot be solved by the described procedures.

■ A.00

A.00 indicates an absolute data error.

Alarm A.00 is reset when the power is turned OFF. An alarm is reset only when the control power supply of the SERVOPACK is off, and the motor shaft is rotated a distance greater than the value specified by the Cn-14 (Absolute Encoder Allowable Error).

Alarm Output

Alarm Output				
Alarm Code Output				Alarm Output
/AL0	/AL1	/AL2	/AL3	
OFF	OFF	OFF	OFF	OFF

ON: Output transistor is ON

OFF: Output transistor is OFF

Status When Lit and Remedies

Cause		Remedy
A	When the control power source of the SERVOPACK was OFF, the motor shaft rotated more than the value specified by the parameter Cn-14.	Reset the machine zero point. (If necessary, increase the value of Cn-14.)
B	Absolute encoder power not supplied from SERVOPACK	Use the encoder power supply on the SERVOPACK.
C	Incorrect wiring of absolute encoder	Check the absolute encoder wiring and rewire correctly.
D	Incorrect parameter setting. Incremental encoder used with Cn-01 Bit E set to 1	Set Cn-01 Bit E to 0.
E	Absolute encoder defective	Replace servomotor.
F	Circuit board defective	Replace SERVOPACK.

■ **A.02**

A.02 indicates a EEPROM sum check error.

Alarm Output

Alarm Output				
Alarm Code Output				Alarm Output
/AL0	/AL1	/AL2	/AL3	
OFF	OFF	OFF	OFF	OFF

ON: Output transistor is ON

OFF: Output transistor is OFF

Status When Lit and Remedies

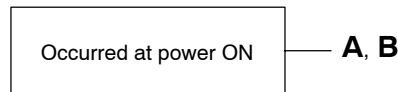

Cause		Remedy
A	Power turned OFF during parameter write. Alarm occurred at the next power ON.	Initialize and reset (or reload) parameters and table settings.
B	Circuit board defective	Replace SERVOPACK.

■ **A.04**

A.04 indicates a parameter setting error.

Alarm Output

Alarm Output				
Alarm Code Output				Alarm Output
/AL0	/AL1	/AL2	/AL3	
OFF	OFF	OFF	OFF	OFF

ON: Output transistor is ON

OFF: Output transistor is OFF

Status When Lit and Remedies

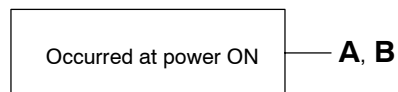

Cause		Remedy
A	An out-of-range parameter was previously set or loaded.	Reset all parameters in range. Otherwise, re-load correct parameters.
B	Circuit board defective	Replace SERVOPACK.

■ A.05

A.05 indicates a SRAM sum check error.

Alarm Output

Alarm Output				
Alarm Code Output				Alarm Output
/AL0	/AL1	/AL2	/AL3	
OFF	OFF	OFF	OFF	OFF

ON: Output transistor is ON

OFF: Output transistor is OFF

Status When Lit and Remedies

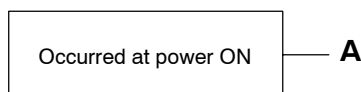

Cause		Remedy
A	<ul style="list-style-type: none"> • Circuit board defective • SRAM defective 	Replace SERVOPACK.

■ **A.06**

A.06 indicates a back-up data sum check error.

Alarm Output

Alarm Output				
Alarm Code Output				Alarm Output
/AL0	/AL1	/AL2	/AL3	
OFF	OFF	OFF	OFF	OFF

ON: Output transistor is ON

OFF: Output transistor is OFF

Status When Lit and Remedies

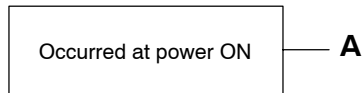

Cause		Remedy
A	<ul style="list-style-type: none"> • Circuit board defective • FLASH memory defective 	Replace SERVOPACK.

■ A.10

A.10 indicates overcurrent.

Alarm Output

Alarm Output				
Alarm Code Output				Alarm Output
/AL0	/AL1	/AL2	/AL3	
ON	OFF	OFF	OFF	OFF

ON: Output transistor is ON

OFF: Output transistor is OFF

Status When Lit and Remedies

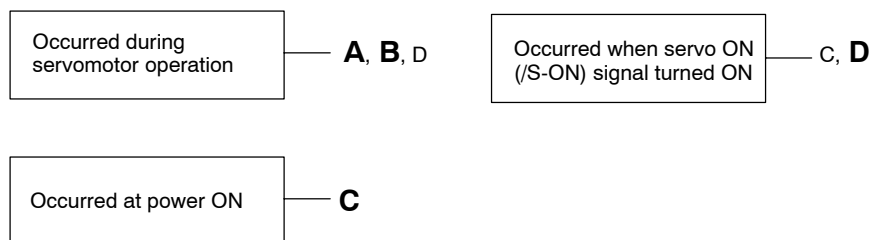

Cause		Remedy
A	Wiring grounded between SERVOPACK and servomotor	Check and correct wiring.
B	Servomotor phase U, V, or W grounded.	Replace servomotor.
C	<ul style="list-style-type: none"> • Circuit board defective • Power transistor defective 	Replace SERVOPACK.
D	Current feedback circuit, power transistor, DB relay, or circuit board defective.	Replace SERVOPACK.

■ **A.30**

A.30 indicates a regenerative alarm.

Alarm Output

Alarm Output				
Alarm Code Output				Alarm Output
/AL0	/AL1	/AL2	/AL3	
ON	ON	OFF	OFF	OFF

ON: Output transistor is ON

OFF: Output transistor is OFF

Status When Lit and Remedies

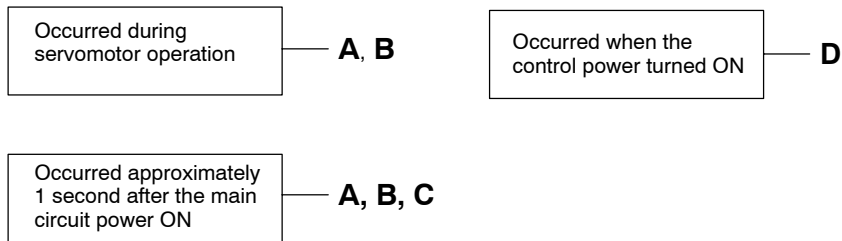

Cause		Remedy
A	Regenerative transistor is abnormal.	Replace SERVOPACK.
B	Disconnection of the regenerative resistor unit	Replace SERVOPACK or regenerative resistor unit.
C	Regenerative resistor unit disconnected (for more than 5.0 kW)	Check wiring of the regenerative resistor unit.
D	SERVOPACK defective.	Replace SERVOPACK.

■ A.40

A.40 indicates a main circuit voltage alarm.

Alarm Output

Alarm Output				
Alarm Code Output				Alarm Output
/AL0	/AL1	/AL2	/AL3	
OFF	OFF	ON	OFF	OFF

ON: Output transistor is ON

OFF: Output transistor is OFF

Status When Lit and Remedies

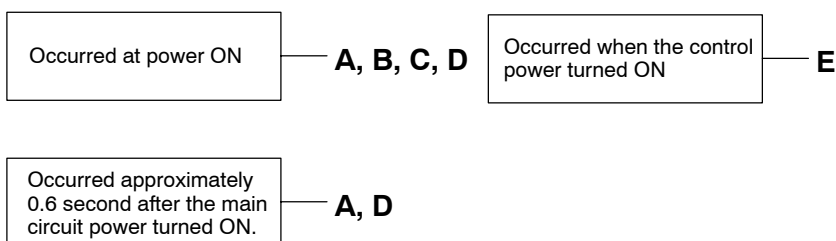

Cause		Remedy
A	The power supply voltage is not within the range of specifications.	Check power supply.
B	Load exceeds capacity of the regenerative unit.	Check specifications of load inertia and overhanging load.
C	Regenerative transistor is abnormal.	Replace SERVOPACK.
D	<ul style="list-style-type: none"> • Rectifying diode defective • Fuse blown • Inrush current-limited resistor disconnected 	
E	SERVOPACK defective	

■ **A.51**

A.51 indicates overspeed.

Alarm Output

Alarm Output				
Alarm Code Output				Alarm Output
/AL0	/AL1	/AL2	/AL3	
ON	OFF	ON	OFF	OFF

ON: Output transistor is ON

OFF: Output transistor is OFF

Status When Lit and Remedies

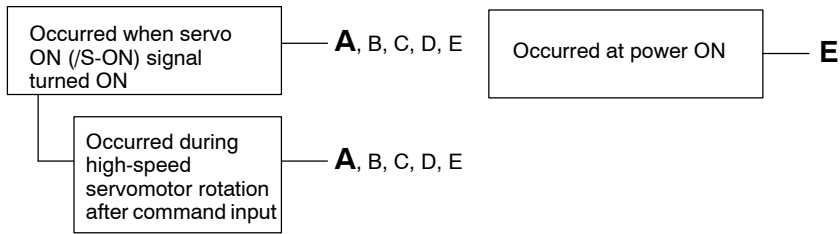

Cause		Remedy
A	<ul style="list-style-type: none"> • Servomotor wiring incorrect. • Encoder wiring incorrect (disconnection, shortcircuit, power supply, etc.) 	Check and correct wiring. (Check phase-A, -B, and -C pulses correct at 2CN.)
B	Incremental encoder power not supplied from SERVOPACK	Use the SERVOPACK power supply for the encoder.
C	Noise in encoder wiring	Separate encoder wiring from main wiring circuits.
D	Incorrect parameter (number of encoder pulses) setting	Set parameter Cn-11 to the correct number of pulses.
E	Circuit board defective	Replace SERVOPACK.

■ A.71

A.71 indicates an overload excessively high overload.

The alarm output, the status when LEDs are lit, and the remedy procedure are identical to those of A.72 below.

■ A.72

A.72 indicates an overload (long-term overload).

Alarm Output

Alarm Output				
Alarm Code Output				Alarm Output
/AL0	/AL1	/AL2	/AL3	
ON	ON	ON	OFF	OFF

ON: Output transistor is ON

OFF: Output transistor is OFF

Status When Lit and Remedies

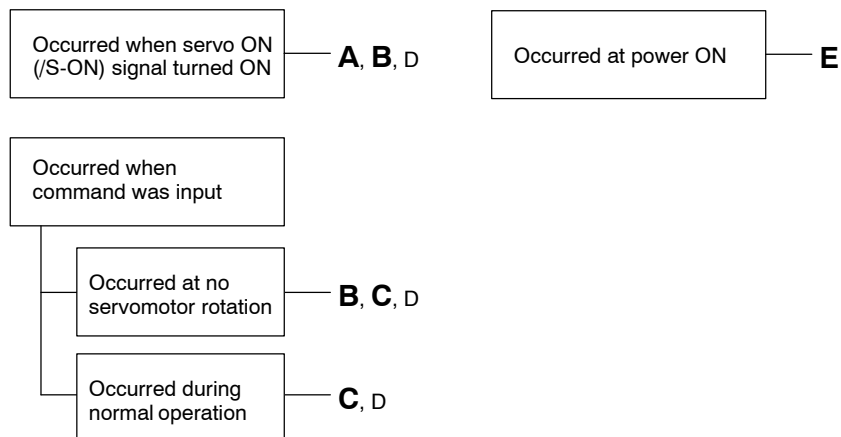

Cause		Remedy
A	Servomotor wiring incorrect or disconnected	Check wiring and connectors at servomotor.
B	Encoder wiring incorrect or disconnected	Check wiring and connectors at encoder.
C	Load greatly exceeds rated torque.	Reduce load torque and inertia. Otherwise, replace with larger capacity servomotor.
D	Incremental encoder power not supplied from SERVOPACK.	Use the SERVOPACK power supply for the encoder.
E	Circuit board defective	Replace SERVOPACK.

■ **A.7A**

A.7A indicates that the heat sink overheated.

Alarm Output

Alarm Output				
Alarm Code Output				Alarm Output
/AL0	/AL1	/AL2	/AL3	
ON	ON	ON	OFF	OFF

ON: Output transistor is ON

OFF: Output transistor is OFF

Status When Lit and Remedies



Cause		Remedy
A	The ambient temperature of the SERVOPACK exceeds 55°C.	Alter conditions so that the ambient temperature goes below 55°C.
B	The air flow around the heat sink is bad.	Follow installing method and provide sufficient surrounding space as specified.
C	Fan stopped.	Replace SERVOPACK.
D	SERVOPACK is running under overload.	Reduce load.
E	SERVOPACK defective	Replace SERVOPACK.

■ A.80

A.80 indicates an encoder error.

Alarm Output

Alarm Output				
Alarm Code Output				Alarm Output
/AL0	/AL1	/AL2	/AL3	
OFF	OFF	OFF	ON	OFF

ON: Output transistor is ON

OFF: Output transistor is OFF

Status When Lit and Remedies



Cause		Remedy
A	Encoder wiring error	Check the encoder wiring and rewire correctly.
B	Circuit board defective	Replace SERVOPACK.
C	Error occurred in absolute encoder. <ul style="list-style-type: none"> Another encoder-related alarm is displayed when the power is turned ON again. 	Turn the SERVOPACK OFF and then ON.
D	SERVOPACK miscounted pulses (positional displacement) or malfunctioned due to noise.	<ul style="list-style-type: none"> Separate encoder wiring from main circuits. Turn the SERVOPACK OFF and then ON.
E	The number of encoder pulses set in the SERVOPACK differs from the number of pulses of the connected encoder.	Set the correct encoder pulse number in Cn-11.

■ **A.81**

A.81 indicates an absolute encoder back-up error. (This alarm only occurs when a 12-bit absolute encoder is used.)

Alarm Output

Alarm Output				
Alarm Code Output				Alarm Output
/AL0	/AL1	/AL2	/AL3	
OFF	OFF	OFF	ON	OFF

ON: Output transistor is ON

OFF: Output transistor is OFF

Status When Lit and Remedies

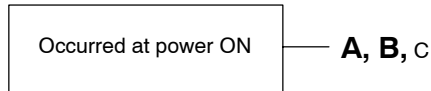

Cause		Remedy
A	The following power supplied to the absolute encoder all failed: <ul style="list-style-type: none"> • +5 V supply • Battery • Internal capacitor 	Initialize the absolute encoder and reset the machine zero point.
B	Circuit board defective	Replace SERVOPACK.
C	Absolute encoder malfunctioned	Replace servomotor.

■ A.82

A.82 indicates an absolute encoder checksum error. (This alarm only occurs when a 12-bit absolute encoder is used.)

Alarm Output

Alarm Output				
Alarm Code Output				Alarm Output
/AL0	/AL1	/AL2	/AL3	
OFF	OFF	OFF	ON	OFF

ON: Output transistor is ON

OFF: Output transistor is OFF

Status When Lit and Remedies



Cause		Remedy
A	Abnormality during absolute encoder memory check	<ul style="list-style-type: none"> Initialize the absolute encoder and reset the machine zero point. Replace servomotor if error occurs frequently.
B	Circuit board defective	Replace SERVOPACK.

* If a checksum error (A.82) occurs during operation, an absolute encoder error (A.80) will be initially generated. The checksum error (A.82) occurs after SERVOPACK is turned OFF and then ON.

■ **A.83**

A.83 indicates that battery voltage is low, or an absolute encoder battery error occurred. (The absolute encoder battery alarm only occurs when a 12-bit absolute encoder is used.)

Alarm Output

Alarm Output				
Alarm Code Output				Alarm Output
/AL0	/AL1	/AL2	/AL3	
OFF	OFF	OFF	ON	OFF

ON: Output transistor is ON

OFF: Output transistor is OFF

Status When Lit and Remedies

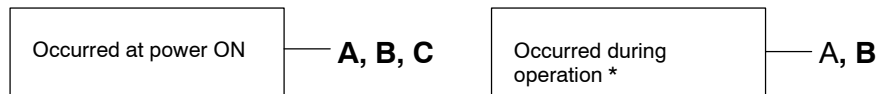

Cause		Remedy
A	<ul style="list-style-type: none"> • Battery not connected • Battery connection defective 	Check and correct battery connection.
B	Battery voltage below specified value Specified value: 2.8 V	Replace the battery and turn SERVOPACK ON.
C	Circuit board defective	Replace SERVOPACK.

* No alarm occurs at the SERVOPACK when a battery error (A.83) is generated. The battery error (A.83) occurs the next time the SERVOPACK turns ON.

■ A.84

A.84 indicates an absolute encoder data alarm. (This alarm only occurs when an absolute encoder is used.)

Alarm Output

Alarm Output				
Alarm Code Output				Alarm Output
/AL0	/AL1	/AL2	/AL3	
OFF	OFF	OFF	ON	OFF

ON: Output transistor is ON

OFF: Output transistor is OFF

Status When Lit and Remedies



Cause		Remedy
A	Absolute encoder malfunctioned	<ul style="list-style-type: none"> • Turn the SERVOPACK OFF and then ON. • Replace servomotor if error occurs frequently.
B	Circuit board defective	Replace SERVOPACK.

* No alarm occurs at the SERVOPACK when a data error (A.84) is generated. The data error (A.84) occurs the next time the SERVOPACK turns ON.

■ **A.85**

A.85 indicates an absolute encoder overspeed. (This alarm only occurs when an absolute encoder is used.)

Alarm Output

Alarm Output				
Alarm Code Output				Alarm Output
/AL0	/AL1	/AL2	/AL3	
OFF	OFF	OFF	ON	OFF

ON: Output transistor is ON

OFF: Output transistor is OFF

Status When Lit and Remedies

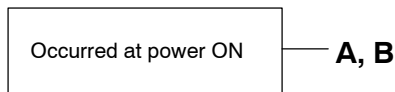

Cause		Remedy
A	Absolute encoder turned ON at a speed exceeding 400 min ⁻¹ .	Turn the SERVOPACK OFF and then ON. If this error occurs frequently, replace the servomotor.
B	Circuit board defective	Replace SERVOPACK.

■ A.b0

A.b0 indicates a hardware error.

This alarm is occasionally not stored in the alarm trace-back function memory.

Alarm Output

Alarm Output				
Alarm Code Output				Alarm Output
/AL0	/AL1	/AL2	/AL3	
ON	ON	OFF	ON	OFF

ON: Output transistor is ON

OFF: Output transistor is OFF

Status When Lit and Remedies



Cause		Remedy
A	SERVOPACK malfunctioned.	Turn the control power ON again.
B	SERVOPACK defective	Replace SERVOPACK.

■ **A.b2**

A.b2 indicates CPU error 1.

Occasionally, this alarm is not displayed via serial communications or on the Digital Operator, but is stored in the alarm trace-back function memory only.

In this case, the 7-segment LED on the SERVOPACK will indicate a CPU error (□), and the Digital Operator will display either “CPF00” or “CPF01.”

Alarm Output

Alarm Output				
Alarm Code Output				Alarm Output
/AL0	/AL1	/AL2	/AL3	
ON	ON	OFF	ON	OFF

ON: Output transistor is ON

OFF: Output transistor is OFF

Status When Lit and Remedies

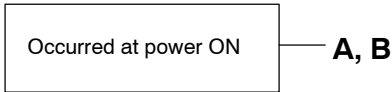

Cause		Remedy
A	SERVOPACK malfunctioned.	Turn the control power ON again.
B	SERVOPACK defective	Replace SERVOPACK.

■ A.b3

A.b3 indicates CPU error 2.

Occasionally, this alarm is not displayed via serial communications or on the Digital Operator, but is stored in the alarm trace-back function memory only.

In this case, the 7-segment LED on the SERVOPACK will indicate a CPU error (□), and the Digital Operator will display either “CPF00” or “CPF01.”

Alarm Output

Alarm Output				
Alarm Code Output				Alarm Output
/AL0	/AL1	/AL2	/AL3	
ON	ON	OFF	ON	OFF

ON: Output transistor is ON

OFF: Output transistor is OFF

Status When Lit and Remedies



Cause		Remedy
A	SERVOPACK malfunctioned.	Turn the control power ON again.
B	SERVOPACK defective	Replace SERVOPACK.

■ **A.C1**

A.C1 indicates a Servo overrun.

Alarm Output

Alarm Output				
Alarm Code Output				Alarm Output
/AL0	/AL1	/AL2	/AL3	
OFF	OFF	ON	ON	OFF

ON: Output transistor is ON

OFF: Output transistor is OFF

Status When Lit and Remedies

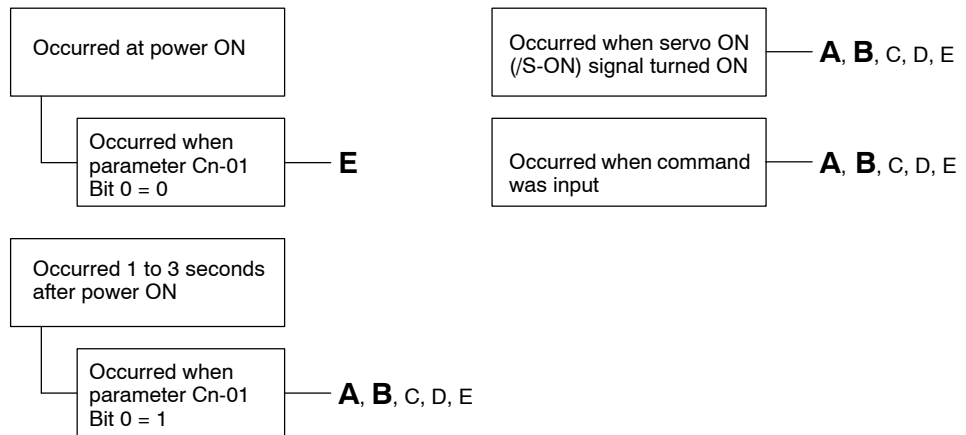

Cause		Remedy
A	Servomotor wiring incorrect	Check wiring and connectors at servomotor.
B	Encoder wiring incorrect	Check wiring and connectors at encoder.
C	Incremental encoder power not supplied from SERVOPACK	Use the SERVOPACK power supply for the encoder.
D	Encoder defective	Replace servomotor.
E	Circuit board defective	Replace SERVOPACK.

■ A.C2

A.C2 indicates that an encoder phase error was detected. (This alarm only occurs when an incremental encoder is used.)

Alarm Output

Alarm Output				
Alarm Code Output				Alarm Output
/AL0	/AL1	/AL2	/AL3	
OFF	OFF	ON	ON	OFF

ON: Output transistor is ON

OFF: Output transistor is OFF

Status When Lit and Remedies

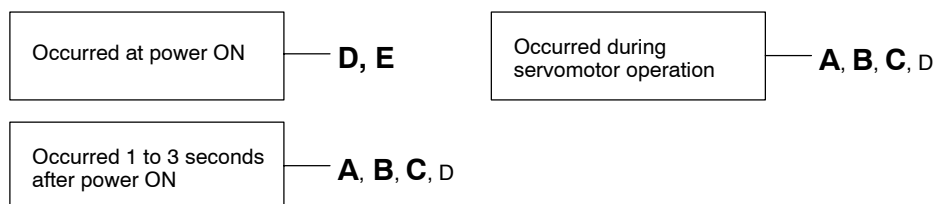

Cause		Remedy
A	Noise in encoder wiring	Separate encoder wiring from main wiring circuits.
B	Encoder wiring incorrect or poor connection	Check wiring and connectors at encoder.
C	Encoder defective	Replace servomotor.
D	Circuit board defective	Replace SERVOPACK.
E	Absolute encoder was used with incremental encoder setting.	Change to absolute encoder setting. (Change bit E of Cn-01 to 1.)

■ **A.C3**

A.C3 indicates an encoder phase A or phase B disconnection.

Alarm Output

Alarm Output				
Alarm Code Output				Alarm Output
/AL0	/AL1	/AL2	/AL3	
OFF	OFF	ON	ON	OFF

ON: Output transistor is ON

OFF: Output transistor is OFF

Status When Lit and Remedies

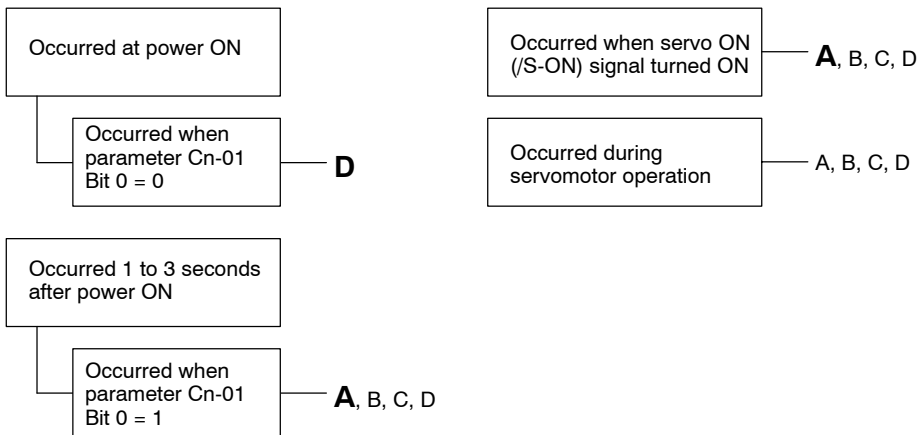

Cause		Remedy
A	Encoder wiring incorrect or poor connection	Check wiring and connectors at encoder.
B	Noise in encoder wiring	Separate encoder wiring from main wiring circuits.
C	Encoder defective	Replace servomotor.
D	Circuit board defective	Replace SERVOPACK.

■ A.C4

A.C4 indicates an encoder phase C disconnection.

Alarm Output

Alarm Output				
Alarm Code Output				Alarm Output
/AL0	/AL1	/AL2	/AL3	
OFF	OFF	ON	ON	OFF

ON: Output transistor is ON

OFF: Output transistor is OFF

Status When Lit and Remedies

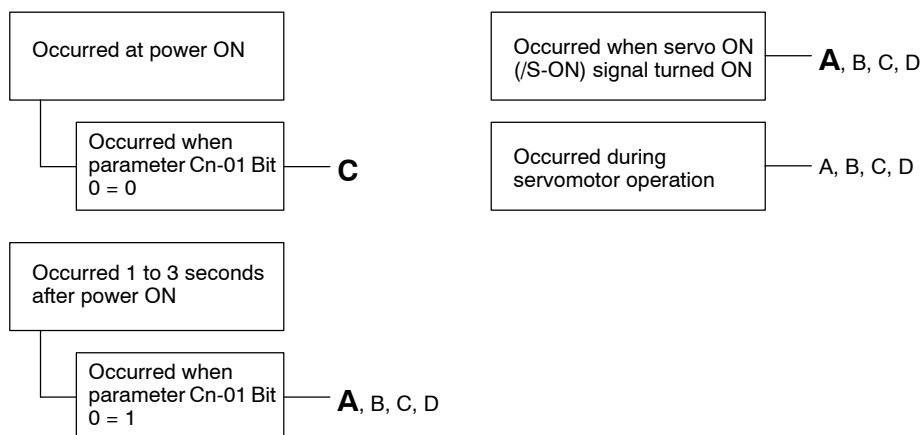

Cause		Remedy
A	Encoder wiring incorrect or poor connection	Check wiring and connectors at encoder.
B	Noise in encoder wiring	Separate encoder wiring from main wiring circuits.
C	Encoder defective	Replace servomotor.
D	Circuit board defective	Replace SERVOPACK.

■ **A.d0**

A.d0 indicates a position error pulse overflow.

Alarm Output

Alarm Output				
Alarm Code Output				Alarm Output
/AL0	/AL1	/AL2	/AL3	
ON	OFF	ON	ON	OFF

ON: Output transistor is ON

OFF: Output transistor is OFF

Status When Lit and Remedies

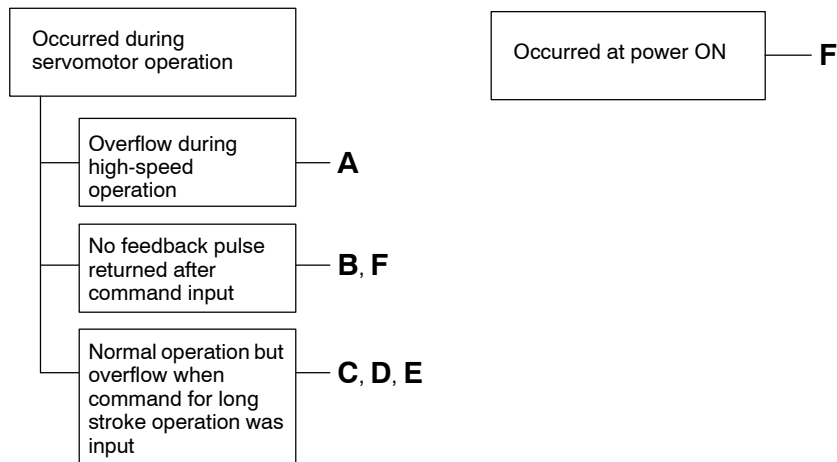

Cause		Remedy
A	Servomotor wiring incorrect	Check and correct wiring. (Check that phase-A, -B, -C pulses are correct at 2CN.)
B	Encoder wiring incorrect (disconnection, shortcircuit, power supply, etc.)	
C	SERVOPACK adjustment incorrect	Increase speed loop gain (Cn-04) and/or position loop gain (Cn-1A).
D	Servomotor overloaded	Reduce load torque and inertia. Otherwise, replace with larger capacity servomotor.
E	<ul style="list-style-type: none"> Position command pulse frequency too high Specified acceleration/deceleration rate too high 	<ul style="list-style-type: none"> Decrease command pulse frequency. Decrease acceleration/deceleration rate. Change electronic gear ratio.
F	Circuit board defective	Replace SERVOPACK.

■ A.F1

A.F1 indicates power line open-phase.

Alarm Output

Alarm Output				
Alarm Code Output				Alarm Output
/AL0	/AL1	/AL2	/AL3	
ON	ON	ON	ON	OFF

ON: Output transistor is ON

OFF: Output transistor is OFF

Status When Lit and Remedies



Cause		Remedy
A	One phase (L1, L2, or L3) of the main circuit power supply is disconnected.	<ul style="list-style-type: none"> • Check power supply. • Check wiring of the main circuit power supply. • Check MCCB, noise filter, and magnetic contactor.
B	There is one phase where the line voltage is low.	Check power supply.
C	SERVOPACK defective	Replace SERVOPACK.

■ **A.F3**

A.F3 indicates a momentary power loss alarm.

Alarm Output

Alarm Output				
Alarm Code Output				Alarm Output
/AL0	/AL1	/AL2	/AL3	
ON	ON	ON	ON	OFF

ON: Output transistor is ON

OFF: Output transistor is OFF

Status When Lit and Remedies

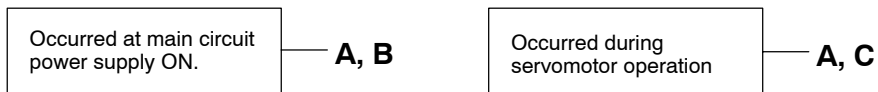

Cause		Remedy
A	Although the momentary power loss alarm is not necessary, its parameter is set valid.	Set the parameter Cn-01 bit 5 to 0.
B	Time between turning power OFF and back ON was shorter than 0.5 second.	After turning power OFF, wait for at least 0.5 second, and then ON again.
C	<p>If any of the following power supply conditions are met during motor operation:</p> <ul style="list-style-type: none"> • Complete power loss: half cycle of supply frequency • Voltage drop: full cycle of supply frequency <p>Note: Because of detector lag or detector margin, there may be no alarm even if the above values are exceeded.</p>	<p>Check the power supply.</p> <p>Terms</p> <ul style="list-style-type: none"> • Complete power loss = Power loss where voltage drops to zero. • Voltage drop = Power loss where voltage drops, but not to zero.

■ CPF00

CPF00 indicates a Digital Operator transmission error 1. This alarm is not stored in alarm trace-back function memory.

Alarm Output

Alarm Output				
Alarm Code Output				Alarm Output
/AL0	/AL1	/AL2	/AL3	
Not specified				

Status When Lit and Remedies

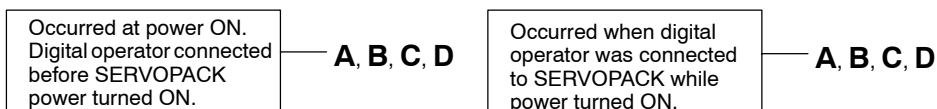

Cause		Remedy
A	Cable defective or poor contact between Digital Operator and SERVOPACK	<ul style="list-style-type: none"> • Check connector connections. • Replace cable.
B	Malfunction due to external noise	Separate Digital Operator and cable from noise source.
C	Digital Operator defective	Replace Digital Operator.
D	SERVOPACK defective	Replace SERVOPACK.

■ **CPF01**

CPF01 indicates a Digital Operator transmission error 2. This alarm is not stored in alarm trace-back function memory.

Alarm Output

Alarm Output				
Alarm Code Output				Alarm Output
/AL0	/AL1	/AL2	/AL3	
Not specified				

Status When Lit and Remedies

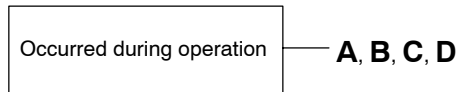

Cause		Remedy
A	Cable defective or poor contact between Digital Operator and SERVOPACK	<ul style="list-style-type: none"> • Check connector connections. • Replace cable.
B	Malfunction due to external noise	Separate Digital Operator and cable from noise source.
C	Digital operator defective	Replace Digital Operator.
D	SERVOPACK defective	Replace SERVOPACK.

■ A.99

Indicates normal operation. Not an alarm.

Alarm Output

Alarm Output				
Alarm Code Output				Alarm Output
/AL0	/AL1	/AL2	/AL3	
OFF	OFF	OFF	OFF	ON

ON: Output transistor is ON

OFF: Output transistor is OFF

■ CPU Error (7-segment LED Display)

Indicates an error in the SERVOPACK CPU.

When this error occurs, the Digital Operator displays “CPF00” or “CPF01.”

A.b2 or A.b3 may be stored in the alarm trace-back function memory.

Alarm Output

Alarm Output				
Alarm Code Output				Alarm Output
/AL0	/AL1	/AL2	/AL3	
OFF	OFF	OFF	OFF	OFF

OFF: Output transistor is OFF

ON: Output transistor is ON

Status When Lit and Remedies



Cause		Remedy
A	SERVOPACK malfunctioned	Turn the control power ON again.
B	SERVOPACK defective	Replace SERVOPACK.

7.2.2 Troubleshooting Problems with No Alarm Display

Refer to the tables below to identify the cause of a problem which causes no alarm display and take the remedy described.

Turn OFF the servo system power supply before commencing the shaded procedures.

Contact your Yaskawa representative if the problem cannot be solved by the described procedures.

Table 7.4 Troubleshooting Table with No Alarm Display

Symptom	Cause	Inspection	Remedy
Servomotor does not start.	Power not turned ON	Check voltage between power supply terminals.	Correct the power circuit.
	Loose connection	Check terminals of connectors (1CN, 2CN, 3CN, 6CN).	Tighten any loose parts.
	Connector (1CN) external wiring incorrect	Check connector (1CN) external wiring.	Refer to connection diagram and correct wiring.
	Servomotor or encoder wiring disconnected	–	Reconnect wiring.
	Overloaded	Run under no load.	Reduce load or replace with larger capacity servomotor.
	Command not input	Check input pins.	Input correctly.
	/S-ON input is turned OFF	(If Cn-01 Bit 0 is 0)	Turn /S-ON input ON.
	Command pulse mode selection incorrect	Refer to 3.9 <i>Pulse Operation Mode</i> .	Select correct parameters Cn-02 Bits 3, 4, 5.
	Encoder type used differs from parameter setting.	Incremental or absolute encoder?	Set parameters Cn-01 Bit E to the encoder type used.
	P-OT and N-OT inputs are turned OFF.	(If Cn-01 Bits 2, 3 are 0)	Turn P-OT and N-OT input signals ON.
Servomotor moves instantaneously, then stops.	Number of encoder pulses used differs from parameter setting.	–	Set the parameter Cn-11 to the number of encoder pulses used.
	Servomotor or encoder wiring incorrect	–	Refer to 3.18 <i>Special Wiring</i> and correct wiring.
Suddenly stops during operation and will not restart.	An alarm occurred with the alarm reset signal /ALM-RST ON.	–	Remove cause of alarm. Turn alarm reset signal /ALM-RST from ON to OFF.
Servomotor speed unstable	Wiring connection to motor defective	Check connection of phase -U, -V, and -W power leads encoder connectors.	Tighten any loose terminals or connectors.

Symptom	Cause	Inspection	Remedy
Servomotor vibrates at approximately 200 to 400 Hz.	Speed loop gain value is too high.	–	Reduce Cn-04 set value for speed loop gain.
High rotation speed overshoot on starting and stopping.	Speed loop gain value is too high.	–	Reduce Cn-04 set value for speed loop gain.
Servomotor overheated	Ambient temperature is too high.	Measure servomotor ambient temperature.	Reduce ambient temperature to 40°C max.
	Servomotor surface dirty	Visual check	Clean dust and oil from motor surface.
	Overloaded	Run under no load.	Reduce load or replace with larger capacity servomotor.
Abnormal noise	Mechanical mounting incorrect	Servomotor mounting screws loose?	Tighten mounting screws.
		Coupling not centered?	Center coupling.
		Coupling unbalanced?	Balance coupling.
	Bearing defective	Check noise and vibration near bearing.	Consult your Yaskawa representative if defective.
	Machine causing vibrations	Foreign object intrusion, damage or deformation of driving parts of machine.	Consult with machine manufacturer if defective.

7.2.3 Internal Connection Diagram and Instrument Connection Examples

The following diagram shows the SGDB-□□AM SERVOPACK internal connection diagram, instrument connection examples, and connections between SERVOPACK and encoder. Refer to these diagrams during inspection and maintenance.

Internal Connection Diagram

0.2 to 1.5 kW

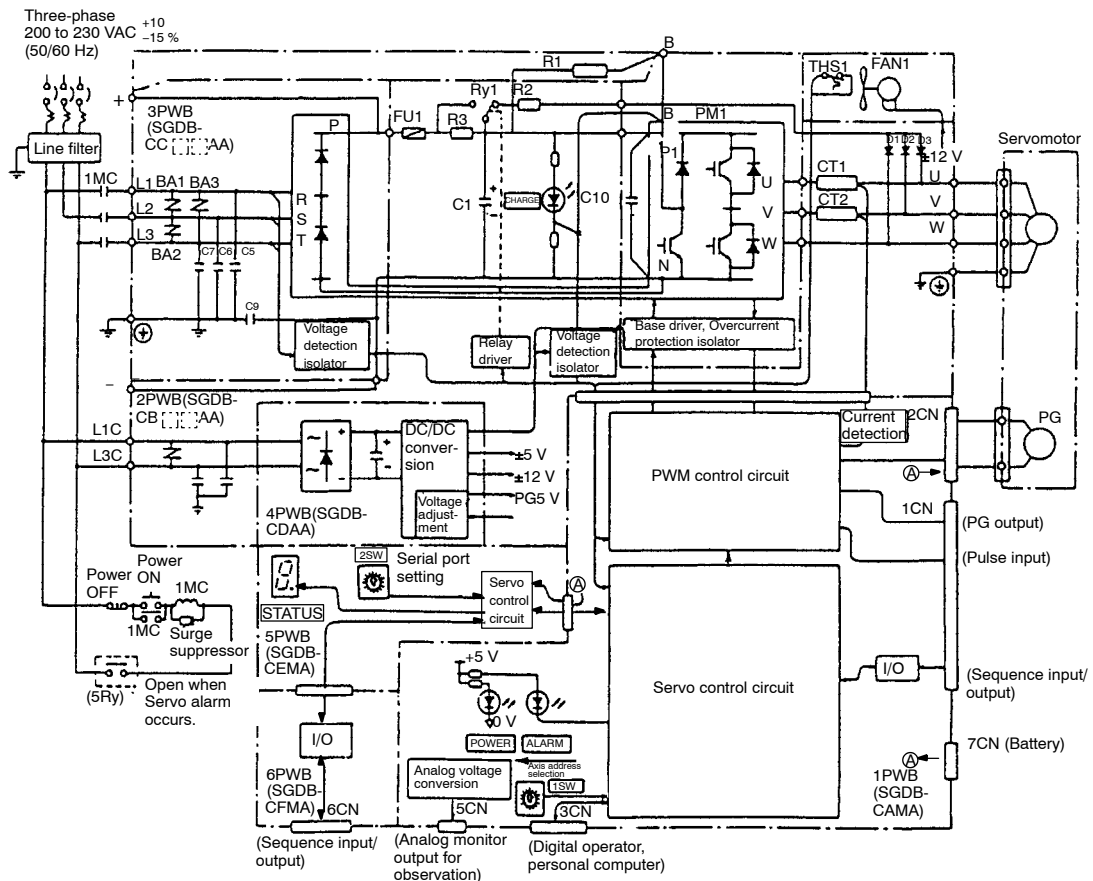

Figure 7.2 Internal Connection Diagram of 0.2 to 1.5 kW SERVOPACK

2.0 to 3.0 kW

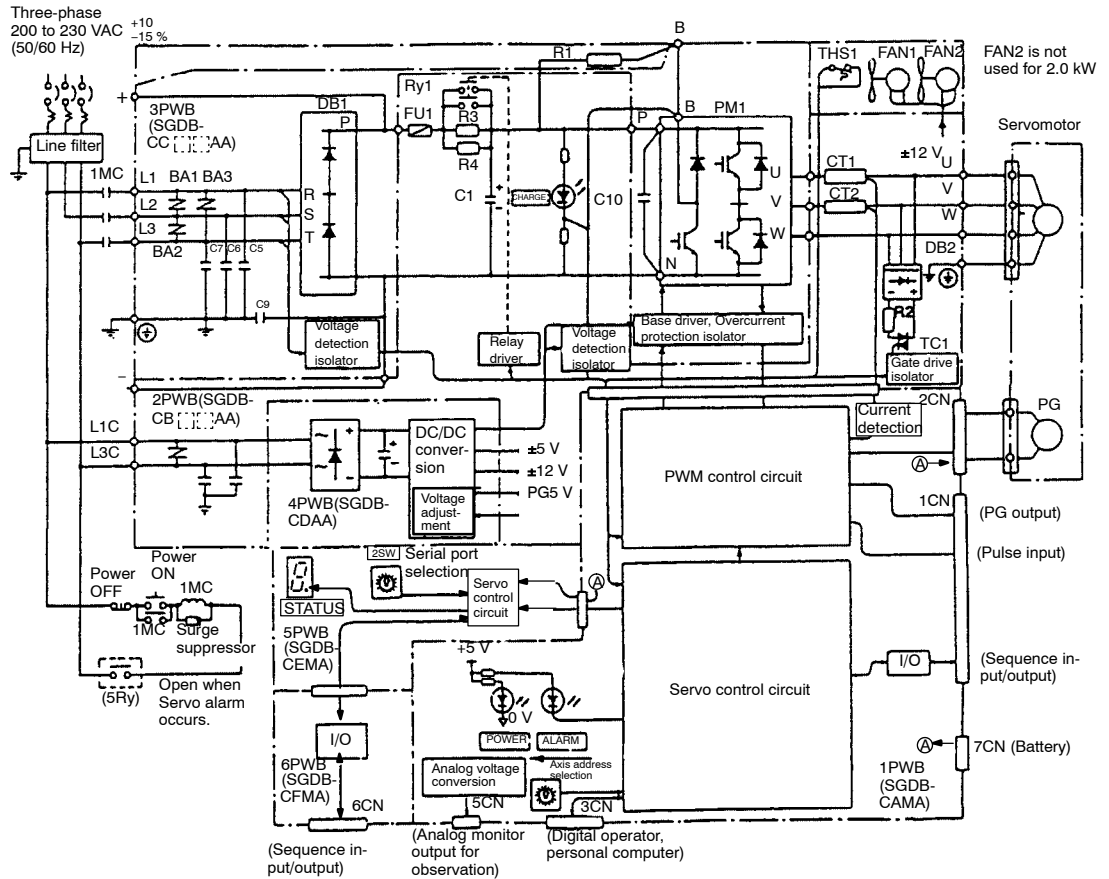

Figure 7.3 Internal Connection Diagram of 2.0 to 3.0 kW SERVOPACK

5.0 to 15.0 kW

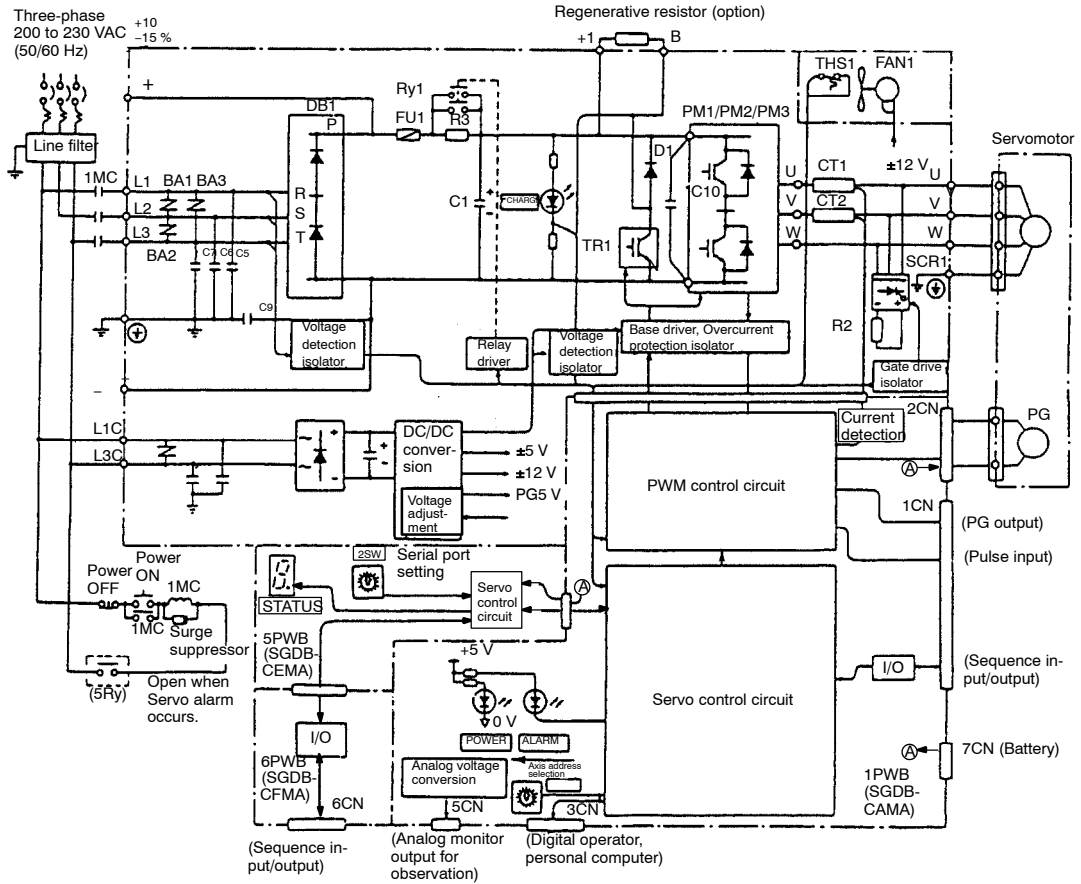
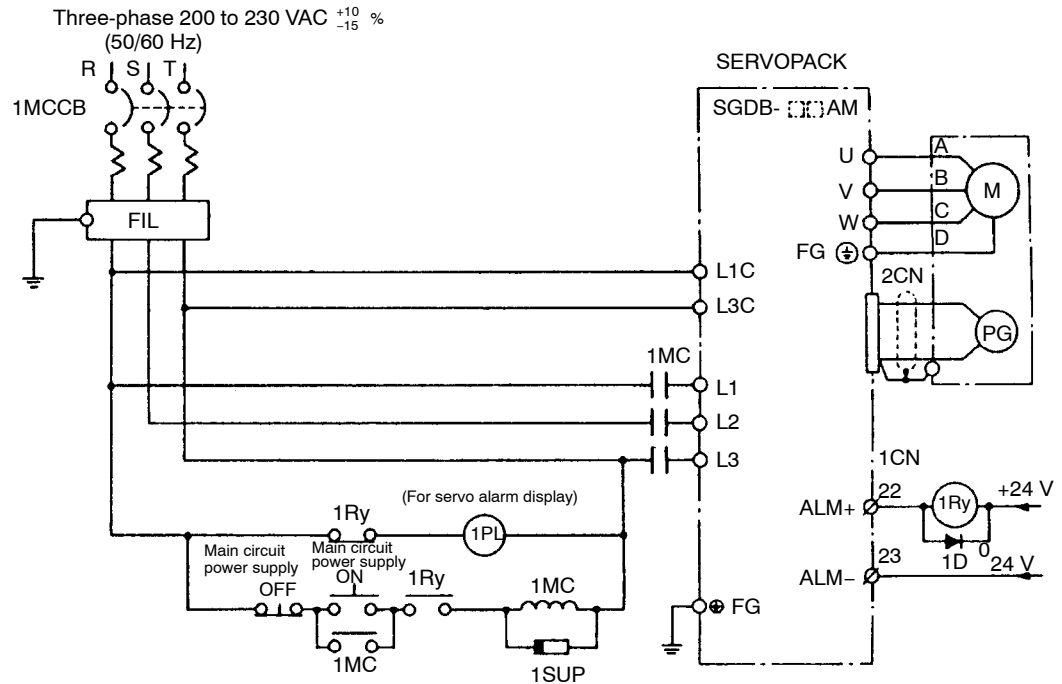

Figure 7.4 Internal Connection Diagram of 5.0 to 15.0 kW SERVOPACK

Instrument Connection Examples

Examples of a SERVOPACK connected to a power supply and a servomotor are shown below. For details on how to connect the SERVOPACK to a host controller, refer to 3.4 to 3.7.



1MCCB: Circuit breaker for wiring (for inverter)
 FIL: Noise filter
 1MC: Contactor
 1Ry: Relay

1PL: Indicator lamp
 1SUP: Surge suppressor
 1D: Flywheel diode

■ **Connections between SERVOPACK and Encoder for SGMS SGMD, and SGMG**

Incremental Encoder

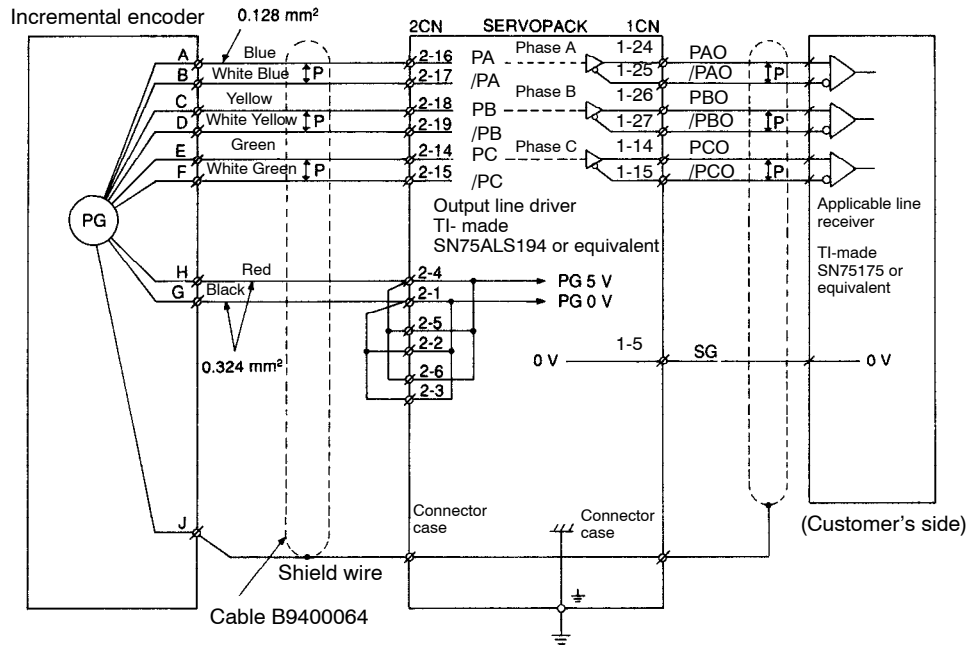

Figure 7.5 Connecting Incremental Encoder and SERVOPACK

Absolute Encoder

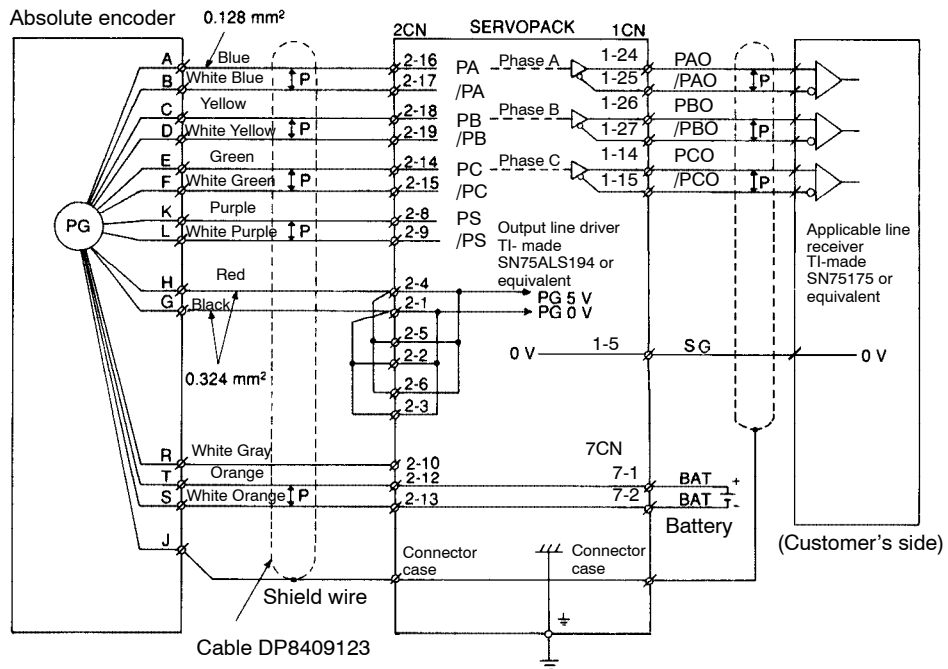

Figure 7.6 Connecting Absolute Encoder and SERVOPACK

■ Connections between SERVOPACK and Encoder for SGM and SGMP

Incremental Encoder

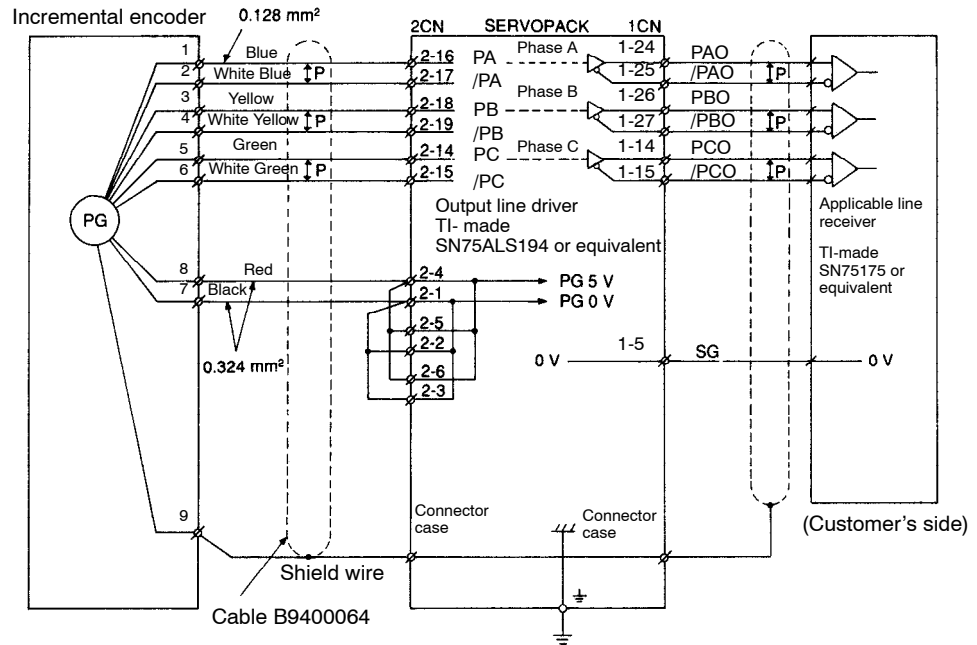

Figure 7.7 Connecting Incremental Encoder and SERVOPACK

Absolute Encoder

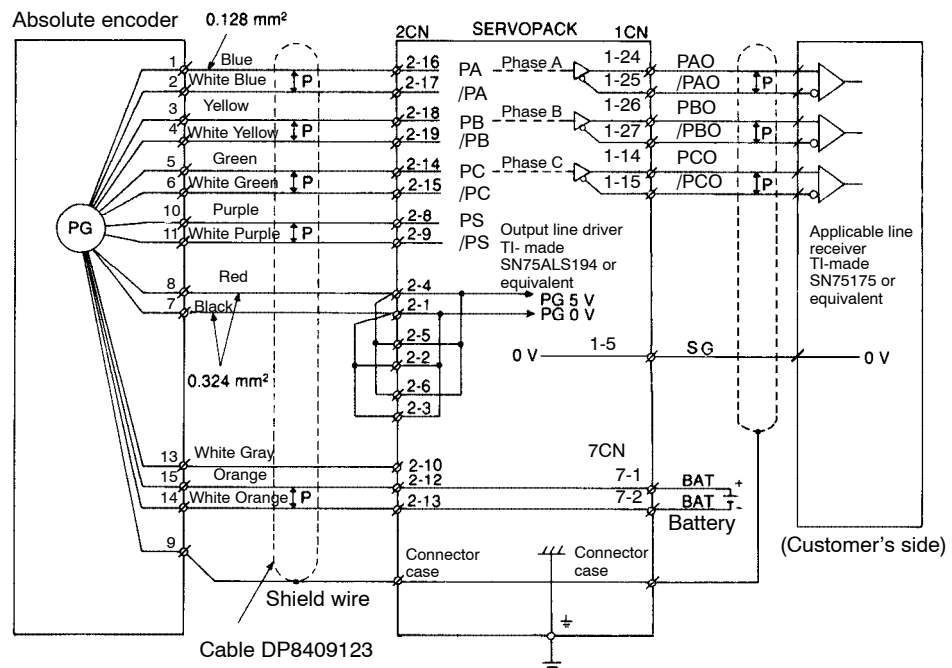

Figure 7.8 Connecting Absolute Encoder and SERVOPACK

A

Servo Adjustment

This appendix presents the basic rules for Σ -Series AC SERVOPACK gain adjustment, describes various adjustment techniques, and gives some pre-set values as guidelines.

A.1	Σ-Series AC SERVOPACK Gain Adjustment	A - 2
A.1.1	Σ -Series AC SERVOPACKs and Gain Adjustment Methods	A - 2
A.1.2	Basic Rules for Gain Adjustment	A - 2
A.2	Adjusting a Position-control SERVOPACK	A - 4
A.2.1	Adjusting Using Auto-tuning	A - 4
A.2.2	Adjusting Manually	A - 5
A.3	Gain Setting References	A - 8
A.3.1	Guidelines for Gain Settings According to Load Inertia Ratio	A - 8

A.1 Σ -Series AC SERVOPACK Gain Adjustment

This section gives some basic information required to adjust the servo system.

A.1.1 Σ -Series AC SERVOPACKs and Gain Adjustment Methods

The SGDB-AM SERVOPACK can be adjusted manually by observing machine responses, or automatically using the SERVOPACK auto-tuning function.

The main parameters changed by the customer to adjust the servo system include the following:

- Cn-04 (Speed Loop Gain)
- Cn-05 (Speed Loop Integration Time Constant)
- Cn-17 (Torque Command Filter Time Constant)
- Cn-1A (Position Loop Gain)

A simple block diagram of the servo system is shown below.

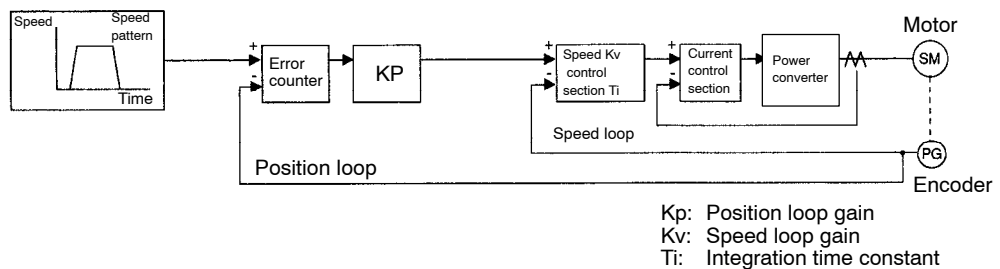

Figure A.1 Servo System Block Diagram

A.1.2 Basic Rules for Gain Adjustment

1. The servo system comprises three feedback systems: position loop, speed loop, and current loop. The response must increase from outer loop to inner loop (see Servo System Block Diagram, above). The response deteriorates and oscillates if this principle is not obeyed. The customer cannot adjust the current loop. Sufficient response is assured for the current loop.

The customer can adjust the position loop gain and speed loop gain, as well as the speed loop integration time constant and torque command filter.

2. The position loop and speed loop must be adjusted to provide a balanced response.

In particular, if the position loop gain only is increased (adjustment with Cn-1A at the SERVOPACK, the speed commands oscillate, and the positioning time extends and oscillates as a result.

If the position loop gain (or Cn-1A) is increased, the speed loop gain (Cn-04) must be similarly increased.

If the mechanical system starts to oscillate after the position loop gain and speed loop gain are increased, do not increase the gains further.

3. The position loop gain should not normally be increased above the characteristic frequency of the mechanical system.

For example, the harmonic gears used in an articulated robot form a structure with extremely poor rigidity and a characteristic frequency of approximately 10 to 20 Hz. This type of machine allows a position loop gain of only 10 to 20 (1/sec).

Conversely, the characteristic frequency of a precision machine tool such as a chip mounter or IC bonder exceeds 70 Hz, allowing a position loop gain exceeding 70 (1/sec) for some machines.

Therefore, although the response of the servo system (servo driver, motor, detectors, etc.) is an important factor where good response is required, it is also important to improve the rigidity of the mechanical system.

4. In cases where the position loop response is greater than the speed loop response and linear acceleration or deceleration is attempted, the poor speed loop response and follow-up cause an accumulation of position loop errors and result in increased output of speed commands from the position loop.

The motor moves faster and overshoots as a result of increased speed commands, and the position loop tends to decrease the speed commands. However, the poor motor follow-up due to the poor speed loop response results in oscillating speed commands, as shown in the diagram below.

If this problem occurs, reduce the position loop gain or increase the speed loop gain to eliminate the speed command oscillations.

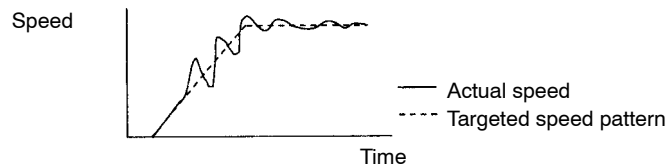

Figure A.2 Behavior with Unbalanced Position Loop Gain and Speed Loop Gain

A.2 Adjusting a Position-control SERVOPACK

This section gives examples of adjusting the gains of a position-control SERVOPACK manually and using auto-tuning.

A.2.1 Adjusting Using Auto-tuning

■ Important Points About Auto-tuning

Speed During Auto-tuning

Auto-tuning may not function correctly if the speed is too low, so set the speed to approximately 500 min⁻¹. Speed is set with the parameter Cn-22 (fourth feed speed).

IMPORTANT

If fourth feed speed is used in normal operation, do not forget to restore the original settings after auto-tuning.

Selecting Machine Rigidity

If the machine rigidity is unknown, select the rigidity according to the following standards.

Drive Method	Machine Rigidity
Ball screw, direct	3 (C-003) to 7 (C-007)
Ball screw, with gears	2 (C-002) to 3 (C-003)
Timing belt	1 (C-001) to 3 (C-003)
Chain	1 (C-001) to 2 (C-002)
Wave gears*	1 (C-001) to 2 (C-002)

* Product name: Harmonic Drive

Select the machine rigidity level according to the table.

Level	Rigidity
7 (C-007)	High
6 (C-006)	⋮
5 (C-005)	⋮
4 (C-004)	⋮
3 (C-003)	Medium
2 (C-002)	⋮
1 (C-001)	Low

Auto-tuning may not end if high rigidity is selected for a low-rigidity machine or low rigidity is selected for a high-rigidity machine.

If this occurs, halt the auto-tuning and change the machine rigidity selection.

■ If Auto-tuning is Unsuccessful

Auto-tuning may be unsuccessful (the end of auto-tuning not displayed) for machines with large play or extremely low rigidity.

Similarly, auto-tuning may be unsuccessful for a machine with high load inertia (exceeding 15 to 30 times the motor moment of inertia).

In these cases, use conventional manual adjustment.

Even if auto-tuning is successful for a machine with large fluctuations in load inertia or load torque, vibrations or noise may still occur in some positions.

■ Response During Operation is Unsatisfactory after Auto-tuning

Auto-tuning sets the gain and integration time constant with some safety margin (to avoid oscillations). This can result in long positioning times.

In particular, the target position may not be reached if low response is selected, because the machine does not move in response to the final minute commands. An excessively high setting of the integration time constant (Cn-05) during auto-tuning is one cause of this problem.

If response is slow, the speed loop gain cannot be manually increased very much after auto-tuning, because increasing the gain causes oscillation.

In this case, manually reduce the integration time constant while observing the machine behavior to ensure oscillation does not occur.

Auto-tuning does not set the torque command filter (Cn-17).

A.2.2 Adjusting Manually

■ Parameters

The role of each parameter is briefly described below.

Speed Loop Gain (Cn-04)

This parameter sets the speed loop response.

The response is improved by setting this parameter to the maximum value in the range which does not cause vibrations in the mechanical system.

The following formula relates the speed loop gain to the load inertia.

$$\text{Speed Loop Gain } K_v \text{ [Hz]} = \frac{2}{\frac{GD_L^2}{GD_M^2} + 1} \times (\text{Cn-04 Preset value})$$

GD_L^2 : Motor Axis Converted Load Inertia

GD_M^2 : Motor Moment of Inertia

Speed Loop Integration Time Constant (Cn-05)

The speed loop has an integration element to allow response to micro-inputs.

This integration element can produce a delay in the servo system, and the positioning setting time increases and response becomes slower as the time constant increases.

However, the integration time constant must be increased to prevent machine vibration if the load inertia is large or the mechanical system includes a vibration elements.

The following formula calculates a guideline value.

$$T_i \geq 2.3 \times \frac{1}{2\pi \times K_v}$$

Ti: Integration Time Constant (sec)

Kv: Speed Loop Gain (Hz)

Torque Command Filter Time Constant (Cn-17)

When a ball screw is used, torsional resonance may occur which increases the pitch of the vibration noise.

These vibrations can sometimes be overcome by increasing the torque command filter time constant.

However, this filter can produce a delay in the servo system, as is the integration time constant, and its value should not be increased more than necessary.

Position Loop Gain (Cn-1A)

The position loop gain parameter determines the servo system response.

The higher the position loop gain is set, the better the response and shorter the positioning times.

To enable a high setting of the position loop gain, increase the machine rigidity and raise the machine characteristic frequency.

Increasing the position loop gain only to improve the response can result in oscillating response of the overall servo system, that is, the speed commands output from the position loop oscillate. Therefore, also increase the speed loop gain while observing the response.

■ Adjustment Procedure

1. Set the position loop gain (Cn-1A) to a low value and increase the speed loop gain (Cn-04) within the range that no abnormal noise or oscillation occurs.
2. Slightly reduce the speed loop gain from the value at step 1, and increase the position loop gain in the range that no overshooting or vibration occurs.
3. Determine the speed loop integration time constant (Cn-05), by observing the positioning set time and vibrations in the mechanical system.
The positioning set time may become excessive if the speed loop integration time constant (Cn-05) is too large.
4. It is not necessary to change the torque command filter time constant (Cn-17) unless torsional resonance occurs in the machine shafts.
Torsional resonance may be indicated by a high vibration noise from the machine system. Adjust the torque command filter time constant to reduce the vibration noise.
5. Finally, fine adjustment of the position gain, speed gain, and integration time constant is required to determine the optimum point for step response, etc.

■ Functions to Improve Response

The mode switch, feed-forward, and bias functions improve response.

However, they are not certain to improve response and may even worsen it in some cases. Follow the points outlined below and observe the actual response while making adjustments.

Mode Switch

The mode switch improves the transition characteristics when the torque commands become saturated during acceleration or deceleration.

Above the set level, the speed loop control switches from PI (proportional/integral) control to P (proportional) control.

Feed-forward Function

Use feed-forward to improve the response speed. However, feed-forward may be ineffective in systems where the value of position loop gain is sufficiently high.

Follow the procedure below to adjust the feed-forward amount (Cn-1D).

1. Adjust the speed loop and position loop, as described above.
2. Gradually increase the feed-forward amount (Cn-1D), such that the positioning complete (/POS1) signal is output early.

At this point, ensure that the positioning complete (/POS1) signal does not brake up (alternately does not turn ON/OFF) and that the speed does not overshoot. These problems can arise if the feed-forward is set too high.

Bias Function

When the lag pulses in the error counter exceeds the positioning complete width (Cn-1B), the bias amount (Cn-1C) is added to the error counter output (speed command). If the lag pulses in the error counter lies within the positioning complete width (Cn-1B), the bias amount (Cn-1C) is no longer added.

This reduces the number of pulses in the error counter and shortens the positioning time.

The motor speed becomes unstable if the bias amount is too large.

Observe the response during adjustment as the optimum value depends on the load, gain, and positioning complete width.

Set Cn-1C to zero (0) when the bias is not used.

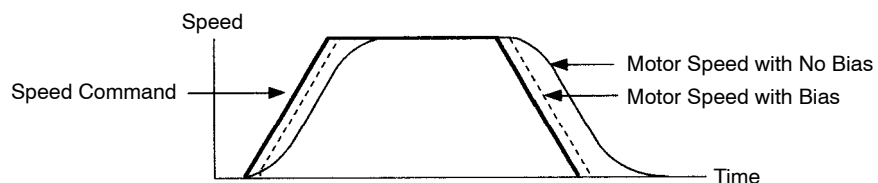

A.3 Gain Setting References

This section presents tables of load inertia values for reference when adjusting the gain.

A.3.1 Guidelines for Gain Settings According to Load Inertia Ratio

Adjustment guidelines are given below according to the rigidity of the mechanical system and load inertia. Use these values as guidelines when adjusting according to the procedures described above.

These values are given as guidelines only. Oscillations and poor response may occur inside the specified value ranges. Observe the response (waveform) to optimize the adjustment.

Higher gains are possible for machines with high rigidity.

■ Machines with High Rigidity

Ball Screw, Direct Drive Machines

Example: Chip moulder, IC bonder, precision machine tools

Load/Inertia Ratio (GD_L^2/GD_M^2)	Position Loop Gain (Cn-1A) [1/s]	Speed Loop Gain (Cn-04)	Speed Loop Integration Time Constant (Cn-05) [ms]
1 ×	50 to 70	50 to 70	5 to 20 * Slightly increase this value for inertia ratio of 20 × , or greater.
3 ×		100 to 140	
5 ×		150 to 200	
10 ×		270 to 380	
15 ×		400 to 560	
20 ×		500 to 730	
30 ×		700 to 1100	

Note: For an inertia ratio of 10 × , or greater, set the position loop gain and speed loop gain to slightly lower values than the values shown and set the speed loop integration time constant to a higher value before starting the adjustment.

As the inertia ratio increases, set the position loop gain and speed loop gain to the lower limit of the range of values specified. Conversely, increase the speed loop integration time constant.

■ Machines with Medium Rigidity

Machines driven by ball screw through gears, or machines directly driven by long ball screws.

Example: General machine tools, orthogonal robots, conveyors

Load/Inertia Ratio (GD_L^2/GD_M^2)	Position Loop Gain (Cn-1A) [1/s]	Speed Loop Gain (Cn-04)	Speed Loop Integration Time Constant (Cn-05) [ms]
1 ×	30 to 50	30 to 50	10 to 40 * Slightly increase this value for inertia ratio of 20 × , or greater.
3 ×		60 to 100	
5 ×		90 to 150	
10 ×		160 to 270	
15 ×		240 to 400	
20 ×		310 to 520	
30 ×		450 to 770	

Note: For an inertia ratio of 10 × , or greater, set the position loop gain and speed loop gain to slightly lower values than the values shown and set the speed loop integration time constant to a higher value before starting the adjustment.

As the inertia ratio increases, set the position loop gain and speed loop gain to the lower limit of the range of values specified. Conversely, increase the speed loop integration time constant.

■ Machines with Low Rigidity

Machines driven by timing belts, chains or wave gears (product name: Harmonic Drive).

Example: Conveyors, articulated robots

Load/Inertia Ratio (GD_L^2/GD_M^2)	Position Loop Gain (Cn-1A) [1/s]	Speed Loop Gain (Cn-04)	Speed Loop Integration Time Constant (Cn-05) [ms]
1 ×	10 to 20	10 to 20	50 to 120 * Slightly increase this value for inertia ratio of 20 × , or greater.
3 ×		20 to 40	
5 ×		30 to 60	
10 ×		50 to 110	
15 ×		80 to 160	
20 ×		100 to 210	
30 ×		150 to 310	

Note: For an inertia ratio of 10 × , or greater, set the position loop gain and speed loop gain to slightly lower values than the values shown and set the speed loop integration time constant to a higher value before starting the adjustment.

As the inertia ratio increases, set the position loop gain and speed loop gain to the lower limit of the range of values specified. Conversely, increase the speed loop integration time constant.

The position loop gain K_p is determined from the following relationship.

$$K_p = \frac{V_s}{\epsilon}$$

K_p [1/s]: Position loop gain

V_s [PPS]: Steady speed command

ϵ : (pulse): Steady error (The number of pulses in the error counter at steady speed.)

A

B

List of I/O Signals

B

This appendix lists the I/O signal terminals (connectors 1CN, 3CN, and 6CN) which are used to connect a SERVOPACK to a host controller or external circuit.

IMPORTANT

1. Refer to *Chapter 3 Advanced Use* for details on how to use I/O signals.
2. The functions of I/O signal terminals differ according to the memory switch and parameter settings.

■ List of 1CN I/O Signals

According to parameter settings, the specifications of some signal terminals on connector 1CN vary.

1CN Terminal Number	Symbol	Signal Name	1CN Terminal Number	Symbol	Signal Name	
1	–		19	/TGON-	Rotation detection output	*3
2	SG	Signal ground	20	/S-RDY+	Servo ready output	*3
3	PULS	Command pulse, line PG pulse	21	/S-RDY-		
4	/PULS	Phase-A input	22	ALM+	Servo alarm output	
5	SG	Signal ground	23	ALM-		
6	SIGN	Command pulse, line PG pulse	24	PAO		
7	/SIGN	Phase-B or sign input	25	/PAO		
8	–		26	PBO	PG division output Phase B	
9	/CC	Line PG machine zero point pulse input	27	/PBO		
10	CC		28	/S-ON		
11	TMON	Torque monitor output	*2	29	/P-CON	Proportional control command input
12	VTG	Speed monitor output	*2	30	P-OT	Forward drive prohibited input
13	–		31	N-OT	Reverse drive prohibited input	
14	PCO	PG division output Phase C	32	STP	Machine zero point return limit switch input	
15	/PCO		33	/P-CL	Forward torque limit input	
16	/BK+	Brake interlock output	*3	34	/N-CL	Reverse torque limit input
17	/BK-		35	+24 V	24 V external power supply input	
18	/TGON+	Rotation detection output	*3	36	–	

* 1. Specification changes according to bit E of Cn-33 and bits 3, 4, and 5 of Cn-02. Refer to *Line PG and Pulse Input Terminals* (page B -3) or *Appendix C*.

* 2. Specification changes according to bits 6 and 7 of Cn-02. Refer to *Analog Monitor Signals* (page B -3).

* 3. Specification changes according to setting of Cn-2D. Refer to *Appendix C* (page C -11).

Line PG and Pulse Input Terminals

Table B.1. Using Line PG (Cannot be Used with Pulse Operation Mode)

Specifications	-				Two-phase Pulse Feed-back with 90° Phase Difference	
Setting 1CN Terminal Number	Bit 5, 4, 3 of Cn-02=0, Bit E of Cn-33=1*		Bit 5, 4 of Cn-02=0, Bit 3 of Cn-02=1, Bit E of Cn-33=1*		Bits 5, 4, 3 of Cn-02 = 0, 1, 0 (x 1) = 0, 1, 1 (x 2) = 1, 0, 0 (x 4) Bit E of Cn-33 = 1	
3	PULS	Not used	PULS	Not used	PULS	Feed-back pulse Phase-A input
4	/PULS		/PULS		/PULS	
6	SIGN		SIGN		SIGN	Feed-back pulse Phase-B input
7	/SIGN		/SIGN		/SIGN	

* Do not set these combinations.

Table B.2. Pulse Operation Mode (Cannot be Used with Line PG Mode)

Specifications	Sign + Pulse Train Input Command		CCW Pulse + CW Pulse Command		Two-phase Pulse Command with 90° Phase Difference	
Setting 1CN Terminal Number	Bit 5, 4, 3 of Cn-02=0, Bit E of Cn-33=0		Bit 5, 4 of Cn-02=0, Bit 3 of Cn-02=0, Bit E of Cn-33=0		Bits 5, 4, 3 of Cn-02 = 0, 1, 0 (x 1) = 0, 1, 1 (x 2) = 1, 0, 0 (x 4) Bit E of Cn-33 = 0	
3	PULS	Command pulse input	PULS	Forward command pulse input (CCW)	PULS	Phase-A command pulse input
4	/PULS		/PULS		/PULS	
6	SIGN	Command sign input	SIGN	Reverse command pulse input (CW)	SIGN	Phase-B command pulse input
7	/SIGN		/SIGN		/SIGN	

Table B.3. Analog Monitor Signals

	Setting	Bit 6 of Cn-02 = 0		Bit 6 of Cn-02 = 1	
11		TRQ-M	Torque monitor	TRQ-M	Command speed monitor
1CN Terminal Number	Setting	Bit 7 of Cn-02 = 0		Bit 7 of Cn-02 = 1	
11		VTG-M	Speed monitor	VTG-M	Position error monitor



■ List of 3CN I/O Signals

3CN Terminal Number	Symbol	Signal Name	Signal Direction
1	TXD	SERVOPACK transmission data (straight)	SERVOPACK →
2	/TXD	SERVOPACK transmission data (inverted)	SERVOPACK →
3	RXD	SERVOPACK reception data (straight)	SERVOPACK ←
4	/RXD	SERVOPACK reception data (inverted)	SERVOPACK ←
5	OPH	Digital Operator dedicated signal	–
6	/RXD	Shorting between pins 6 and 7 inserts a 220 Ω terminating resistor between RXD and /RXD.	
7	RT		
8	5VPP	Digital Operator dedicated signal	–
9	GND	0 V for signal	–

■ List of 6CN I/O Signals

The usage of the signal terminals on connector 6CN differs according to the command mode that has been set.

Table B.4. Station Number Command Method (Cn-27 = 0)

6CN Terminal Number	Symbol	Signal Name	6CN Terminal Number	Symbol	Signal Name
1	0V1	0 V input 1	26	0V2	0 V input 2
2	/AUT-LT	Automatic operation mode output	27	/ERR	Command error output
3	/MAN-LT	Manual operation mode output	28	/P0	Current station position output (1)
4	/POS1	Positioning completed output (COIN)	29	/P1	Current station position output (2)
5	/POS2	Positioning near output (NEAR)	30	/P2	Current station position output (3)
6	/AL0	Alarm code output (1)	31	/P3	Current station position output (4)
7	/AL1	Alarm code output (2)	32	/P4	Current station position output (5)
8	/AL2	Alarm code output (4)	33	/CD0	Command data input (0)
9	/AL3	Alarm code output (8)	34	/CD1	Command data input (1)
10	–		35	/CD2	Command data input (2)
11	–		36	/CD3	Command data input (3)
12	–		37	/CD4	Command data input (4)
13	/ZRN	Machine zero point return mode setting input	38	/CD5	Command data input (5)
14	/MAN	Manual operation mode setting input	39	/CD6	Command data input (6)
15	/PULS	Pulse operation mode setting input	40	/CD7	Command data input (7)
16	/MCW	Manual operation input (reverse)	41	/CD8	Command data input (8)
17	/MCCW	Manual operation input (forward)	42	/CD9	Command data input (9)
18	/RST	Reset input	43	/CD10	Command data input (10)
19	/SP2ND	Speed selection code input 2	44	/CD11	Command data input (11)
20	/SP3RD	Speed selection code input 3	45	/DR0	Rotating direction select input 1
21	/LPG	Line PG selection input	46	/DR1	Rotating direction select input 2
22	/AST	Start command input	47	/PS0	Station number read select input 0
23	/ALMRST	Alarm reset input	48	/PS1	Station number read select input 1
24	/STOP	Pause input	49	+24V2	+24 V input 2
25	+24V1	+24 V input 1	50	–	

Table B.5. Digital Switch Command Method (Cn-27 = 1)

6CN Terminal Number	Symbol	Signal Name	6CN Terminal Number	Symbol	Signal Name
1	0V1	0 V input 1	26	0V2	0 V input 2
2	/AUT-LT	Automatic operation mode output	27	/ERR	Command error output
3	/MAN-LT	Manual operation mode output	28	/DSO0	Data strobe output (0)
4	/POS1	Positioning completed output (COIN)	29	/DSO1	Data strobe output (1)
5	/POS2	Positioning near output (NEAR)	30	/DSO2	Data strobe output (2)
6	/AL0	Alarm code output (1)	31	/DSO3	Data strobe output (3)
7	/AL1	Alarm code output (2)	32	/DSO4	Data strobe output (4)
8	/AL2	Alarm code output (4)	33	/DSI10	Position data input (0)
9	/AL3	Alarm code output (8)	34	/DSI11	Position data input (1)
10	–		35	/DSI12	Position data input (2)
11	–		36	/DSI13	Position data input (3)
12	–		37	/DSI14	Position data input (4)
13	/ZRN	Machine zero point return mode setting input	38	/DSI15	Position data input (5)
14	/MAN	Manual operation mode setting input	39	/DSI16	Position data input (6)
15	/PULS	Pulse operation mode setting input	40	/DSI17	Position data input (7)
16	/MCW	Manual operation input (Reverse)	41	/DSI20	Speed data input (0)
17	/MCCW	Manual operation input (Forward)	42	/DSI21	Speed data input (1)
18	/RST	Reset input	43	/DSI22	Speed data input (2)
19	/SP2ND	Speed selection code input 2	44	/DSI23	Speed data input (3)
20	/SP3RD	Speed selection code input 3	45	/DSI24	Speed data input (4)
21	/LPG	Line PG selection input	46	/DSI25	Speed data input (5)
22	/AST	Start command input	47	/DSI26	Speed data input (6)
23	/ALMRST	Alarm reset input	48	/DSI27	Speed data input (7)
24	STOP	Pause input	49	+24V2	+24 V input 2
25	+24V1	+24 V input 1	50	–	

Table B.6. Serial Communications Method (Cn-27 = 2)

6CN Terminal Number	Symbol	Signal Name	6CN Terminal Number	Symbol	Signal Name
1	0V1	0 V input 1	26	0V2	0 V input 2
2	/AUT-LT	Automatic operation mode output	27	/ERR	Command error output
3	/MAN-LT	Manual operation mode output	28	–	
4	/POS1	Positioning completed output (COIN)	29	–	
5	/POS2	Positioning near output (NEAR)	30	–	
6	/AL0	Alarm code output (1)	31	–	
7	/AL1	Alarm code output (2)	32	–	
8	/AL2	Alarm code output (4)	33	–	
9	/AL3	Alarm code output (8)	34	–	
10	–		35	–	
11	–		36	–	
12	–		37	–	
13	/ZRN	Machine zero point return mode setting input	38	–	
14	/MAN	Manual operation mode setting input	39	–	
15	/PULS	Pulse operation mode setting input	40	–	
16	/MCW	Manual operation input (Reverse)	41	–	
17	/MCCW	Manual operation input (Forward)	42	–	
18	/RST	Reset input	43	–	
19	/SP2ND	Speed selection code input 2	44	–	
20	/SP3RD	Speed selection code input 3	45	–	
21	/LPG	Line PG selection input	46	–	
22	/AST	Start command input	47	–	
23	/ALMRST	Alarm reset input	48	–	
24	STOP	Pause input	49	+24V2	+24 V input 2
25	+24V1	+24 V input 1	50	–	

B

Table B.7. Command Table Method (Cn-27 = 4)

6CN Terminal Number	Symbol	Signal Name	6CN Terminal Number	Symbol	Signal Name
1	0V1	0 V input 1	26	0V2	0 V input 2
2	/AUT-LT	Automatic operation mode output	27	/ERR	Command error output
3	/MAN-LT	Manual operation mode output	28	/P0	Zone signal output (1)
4	/POS1	Positioning completed output (COIN)	29	/P1	Zone signal output (2)
5	/POS2	Positioning near output (NEAR)	30	/P2	Zone signal output (3)
6	/AL0	Alarm code output (1)	31	/P3	Zone signal output (4)
7	/AL1	Alarm code output (2)	32	/P4	Zone signal output (5)
8	/AL2	Alarm code output (4)	33	/CD0	Position number data input (0)
9	/AL3	Alarm code output (8)	34	/CD1	Position number data input (1)
10	–		35	/CD2	Position number data input (2)
11	–		36	/CD3	Position number data input (3)
12	–		37	/CD4	Position number data input (4)
13	/ZRN	Machine zero point return mode setting input	38	/CD5	Position number data input (5)
14	/MAN	Manual operation mode setting input	39	/CD6	Position number data input (6)
15	/PULS	Pulse operation mode setting input	40	/CD7	Position number data input (7)
16	/MCW	Manual operation input (Reverse)	41	/CD8	Position number data input (8)
17	/MCCW	Manual operation input (Forward)	42	–	
18	/RST	Reset input	43	–	
19	/SP2ND	Speed selection code input 2	44	–	
20	/SP3RD	Speed selection code input 3	45	–	
21	/LPG	Line PG selection input	46	–	
22	/AST	Start command input	47	/PS0	Zone signal read selection input 0
23	/ALMRST	Alarm reset input	48	/PS1	Zone signal read selection input 1
24	STOP	Pause input	49	+24V2	+24 V input 2
25	+24V1	+24 V input 1	50	–	

C

List of Parameters

C

Σ-Series SERVOPACKs provide many functions, and have parameters to allow the user to select each function and perform fine adjustment. This appendix lists these parameters.

Parameters are divided into the following two types:

Memory switches Cn-01, Cn-02, Cn-26, Cn-29, Cn-32, Cn-33, Cn-39	Each bit of this switch is turned ON or OFF to select a function.
Parameter settings other than those above	A numerical value such as a torque limit value or speed loop gain is set in this parameter.

IMPORTANT

1. Refer to *Chapter 3 Advanced Use* for details on how to use parameters.
2. For details on how to set parameters, refer to *5.1.7 Parameter Setting Mode*.

Table C.1. List of Parameters (Parameter Settings)

Parameter No.	Name	Unit	Lower Limit	Upper Limit	Factory Setting	Remarks
Cn-00	Not a parameter	(Used to select special mode of Digital Operator)				
Cn-01	Memory Switch	(See page C -5)* ¹				
Cn-02	Memory Switch	(See page C -7) (Off-line setting except for bits 6, 7, and E)* ¹				
Cn-03	Speed limit	× 1000 command units/min.	1	240000	10000	
Cn-04	Speed loop gain	Hz	1	4000	80	*2
Cn-05	Speed loop integration time constant	× 0.01 ms	200	51200	2000	*2
Cn-06	Forward rotation stored stroke limit	Command unit	-99999999	+99999999	+99999999	*1
Cn-07	Reverse rotation stored stroke limit	Command unit	-99999999	+99999999	-99999999	*1
Cn-08	Forward torque limit	%	0	800	800	
Cn-09	Reverse torque limit	%	0	800	800	
Cn-0A	PG dividing pulse number	P/R	16	32768	8192	*1
Cn-0B	Zero-speed level	min ⁻¹	1	10000	20	
Cn-0C	Mode switch	(See page C -8)				
Cn-0D	Backlash compensation	Pulse	-30000	+30000	0	
Cn-0E	Reserved				0	
Cn-0F	Reserved				0	
Cn-10	Torque limit	%	0	800	800	
Cn-11	Number of encoder pulses	P/R	513	32768	8192	*1
Cn-12	Base block waiting time	× 10 ms	0	50	0	
Cn-13	Group designation number		1	9	1	*1
Cn-14	Absolute encoder allowable error	Pulse	0	20000000	8192	*1
Cn-15	Brake waiting speed	min ⁻¹	0	500	100	
Cn-16	Brake waiting time	× 10 ms	10	100	50	
Cn-17	Torque command filter time constant	× 0.1 ms	0	250	6.0 kW or less: 4 7.5 kW: 8 11.0 to 15.0 kW: 16	
Cn-18	Feed speed setting method	(See page C -8)	00	44	22	



Parameter No.	Name	Unit	Lower Limit	Upper Limit	Factory Setting	Remarks
Cn-19	S-curve acceleration/deceleration time	ms	0	1000	0	
Cn-1A	Position loop gain	1/s	1	1000	40	*2
Cn-1B	Positioning completed range	Command unit	0	250	7	
Cn-1C	Bias	min ⁻¹	0	450	0	
Cn-1D	Feed forward gain	%	0	100	0	
Cn-1E	Overflow level	× 256 command units	1	32767	1024	
Cn-1F	1 st feed speed	× 1000 command units/min.	1	240000	500	
Cn-20	2 nd feed speed	× 1000 command units/min.	1	240000	100	
Cn-21	3 rd feed speed	× 1000 command units/min.	1	240000	200	
Cn-22	4 th feed speed	× 1000 command units/min.	1	240000	300	
Cn-23	Command units per machine revolution	Command unit	1	1500000	32768	*1
Cn-24	Electronic gear on motor side (numerator)	× 1 rotation	1	65535	4	*1
Cn-25	Electronic gear on load side (denominator)	× 4 rotation	1	65535	1	*1
Cn-26	Command coordinate mode	(See page C -9)				*1
Cn-27	Position command method	(See page C -9)	0	4	2	*1
Cn-28	Station number		1	4096	1	*1
Cn-29	Zero point return mode	(See page C -10)				*1
Cn-2A	Motor selection	(See page C -10)	0	254	Varies according to capacity	*1
Cn-2B	Positioning near range	Command unit	0	3000	20	
Cn-2C	PG power supply voltage	× 0.1 mV	52000	58000	52500	
Cn-2D	Output signal selection	(See page C -11)	111	666	214	*1
Cn-2E	Machine zero point return feed speed	× 1000 command units/min.	1	240000	200	

List of Parameters

Parameter No.	Name	Unit	Lower Limit	Upper Limit	Factory Setting	Remarks
Cn-2F	Machine zero point return approach speed	× 1000 command units/min.	1	240000	100	
Cn-30	Machine zero point return creep speed	× 1000 command units/min.	1	240000	50	
Cn-31	Machine zero point return final distance traveled	Command unit	-99999999	+99999999	8192	
Cn-32	Function selection 1	(See page C -12)				*1
Cn-33	Function selection 2	(See page C -13)				*1
Cn-34	Position loop gain 2	1/s	1	1000	40	
Cn-35	Position loop gain changeover point	Command unit	0	10000	0	
Cn-36	Speed loop gain 2	Hz	1	4000	80	
Cn-37	Speed loop gain changeover point	Command unit	0	10000	0	
Cn-38	Digital switch read scan time	ms	12	2000	24	*1
Cn-39	Acceleration/deceleration type setting	(See page C -15) (Off-line setting except for bits 8, A, C, and E)*1				
Cn-3A	Linear acceleration/deceleration time 1	ms	8	60000	100	
Cn-3B	Linear acceleration/deceleration time 2	ms	8	60000	100	
Cn-3C	Linear acceleration/deceleration switching speed	× 1000 command units/min.	0	240000	10000	
Cn-3D	Exponential acceleration/deceleration time constant	ms	8	1000	100	
Cn-3E	Exponential acceleration/deceleration bias speed	× 1000 command units/min.	0	240000	0	
Cn-3F	Decimal point position and digit number shift		0	7	0	*1

Note: Parameters in must be set and checked before turning ON the motor.

* 1. Changes to this setting become valid after turning OFF and then ON the power.

* 2. Set automatically by the auto-tuning function.

Table C.2. List of Parameters (Memory Switch Settings) Cn-01

Function	Parameter No.	Bit No.	Setting		Factory Setting
Input signal enable/disable	Cn-01	0	0	1	0
			Uses servo ON input (/S-ON).	Does not use Servo ON signal (/S-ON). Servo is always ON.	
		1	Reserved: Setting = 0 (Do not change this setting.)		0
		2	0	1	0
			Uses forward rotation prohibited input (P-OT).	Does not use forward rotation prohibited input (P-OT). Forward rotation is always possible.	
		3	0	1	0
Uses reverse rotation prohibited input (N-OT).	Does not use reverse rotation prohibit input (N-OT). Reverse rotation is always possible.				
/ERR signal mask at serial communication error	4	0	1	0	
		Do not mask.	Mask the /ERR signal at the serial communication.		
Processing performed at recovery from power loss	5	0	1	0	
		After recovery from power loss, does not activate Servo alarm.	After recovery from power loss, activates Servo alarm.		
Sequence selection at abnormal stop	6	0	1	0	
		At base block, stops motor with dynamic brake (DB).	At base block, allows the motor to coast to a stop.		
	7	0	1	*1	
		At base block, stops motor with dynamic brake (DB) then releases brake.	At base block, stops motor with dynamic brake (DB) then does not release brake.		
	8	0	1	0	
		When overtravel is detected (P-OT, N-OT), stops the motor using the method determined by bit 6.	When overtravel is detected (P-OT, N-OT), decelerates the motor to a stop using maximum torque.		
	9	0	1	0	
		When overtravel is detected (P-OT, N-OT), decelerates the motor to a stop using maximum torque, then turns OFF the servo.	When overtravel is detected (P-OT, N-OT), decelerates the motor to a stop using maximum torque, then executes zero-clamp.		



Function	Parameter No.	Bit No.	Setting				Factory Setting
Reserved	Cn-01	A	Reserved: Setting = 0 (Do not change this setting.)				0
Mode switch selection		B	0	1		0	
			Uses mode switch function. Based on the settings in Cn-01 bits D and C.		Does not use mode switch function.		
		D, C	0, 0	0, 1	1, 0	1, 1	0, 0
			Uses internal torque command as a condition. (Level setting: Cn-0C)	Uses speed command as a condition. (Level setting: Cn-0D)	Uses acceleration as a condition. (Level setting: Cn-0E)	Uses error pulse as a condition. (Level setting: Cn-0E)	
Encoder selection		E	0		1		0
	Uses incremental encoder.		Uses absolute encoder.				
Reserved	F	Reserved: Setting = 0 (Do not change this setting.)				0	

Note: : Parameters in must be set and checked before turning ON the motor.

* 1. 1.5 kW or less: 1; 2.0 kW or more: 0

IMPORTANT

Changes to Cn-01 memory switch settings become valid after turning OFF and then ON the power.

Table C.3. List of Parameters (Memory Switch Settings) Cn-02

Function	Parameter No.	Bit No.	Setting					Factory Setting
Rotating direction select	Cn-02	0	0		1			0
			Defines counterclockwise (CCW) rotation as forward rotation.		Defines clockwise (CW) rotation as forward rotation. (Reverse rotation mode)			
Motor zero point error processing selection		1	0		1			0
			Detects motor zero point error		Does not detect motor zero point error.			
Analog speed limit function		2	Reserved: Setting = 0 (Do not change this setting.)					0
Command or line PG pulse form		5, 4, 3	0, 0, 0	0, 0, 1	0, 1, 0	0, 1, 1	1, 0, 0	0, 0, 0
			Sign + Pulse	CW + CCW	Phase A + phase B (×1)	Phase A + phase B (×2)	Phase A + phase B (×4)	
Analog monitor selection		6	0		1			0
			Outputs torque command to TRQ-M.		Outputs speed command to TRQ-M.			
		7	0		1			0
	Outputs present speed to VTG-M.		Outputs position error to VTG-M.					
Reserved	8	Reserved: Setting = 0 (Do not change this setting.)					0	
Reserved	9	Reserved: Setting = 0 (Do not change this setting.)					0	
Reserved	A	Reserved: Setting = 0 (Do not change this setting.)					0	
Reserved	B	Reserved: Setting = 0 (Do not change this setting.)					0	
Torque filter	C	0		1			*	
		Uses torque filter as primary filter.		Uses torque filter as secondary filter.				
Input pulse form	D	0		1			0	
		Does not invert input pulse logic.		Inverts input pulse logic.				



Function	Parameter No.	Bit No.	Setting		Factory Setting
Position error monitor unit	Cn-02	E	0	1	0
			Displays position error as $\times 1$ command units for analog monitor.	Displays position error as $\times 100$ command units for analog monitor.	
Reserved		F	Reserved: Setting = 0 (Do not change this setting.)		0

* 5 kW or less: 0; 6.0 kW or more: 1

IMPORTANT

Changes to Cn-02 memory switch settings become valid after turning OFF and then ON the power. However, bits 6, 7, and E become valid immediately after setting.

■ Mode Switch Changeover Level (Cn-0C) Settings

Sets the mode switch changeover level. The setting range and units vary according to the settings of the mode switch changeover conditions (bits C and D of memory switch Cn-01).

Mode Switch Changeover Conditions (Cn-01 bits D,C)	Unit	Lower Limit	Upper Limit
According to torque command (0,0)	%	0	800
According to speed command (0,1)	min^{-1}	0	10000
According to acceleration (1,0)	$\times 10 \text{ min}^{-1}/\text{s}$	0	3000
According to error pulse (1,1)	Command unit	0	10000

■ Feed Speed Setting Method (Cn-18) Settings

1's digit	Feed speed setting method in automatic operation mode
10's digit	Feed speed setting method in manual operation mode

Setting	Function
0	Selected from parameters through contact inputs
1	Digital switches
2	Serial communications
4	Speed table

■ Command Coordinate Mode (Cn-26) Settings

Function	Bit No.	Setting		Factory Setting
		0	1	
External position indicator display mode	0	0	1	0
		Displays the present position.	Displays the value accumulated from the start of automatic operation.	0
Finite/Infinite length mode selection	1	0	1	0
		Finite length	Infinite length	
Linear/Rotary mode selection	2	0	1	0
		Linear	Rotary	
Position command method	3	0	1	0
		Absolute	Incremental	
Position data code of station number and digital switch command mode	4	0	1	0
		Binary	BCD	
Reserved	5 to F	Reserved: Setting = 0 (Do not change this setting.)		0

IMPORTANT

If Cn-26 is set to in finite length and linear mode and the power is turned OFF and then ON again, an A.04 Alarm (Parameter Setting Alarm) is detected.

■ Position Command Method (Cn-27) Settings

Setting	Function
0	Station numbers
1	Digital switches
2	Serial communications
4	Command table

■ Zero point Return Mode (Cn-29) Settings

Function	Bit No.	Setting			Factory Setting
Zero point return	0	0	1		0
		Does not use.	Uses.		
Reserved	1	Reserved: Setting = 0 (Do not change this setting.)			0
Zero point return mode setting	3, 2	0, 0	0, 1	1, 1	0, 1
		Mode I	Mode II	Mode III	
Zero point return method	4	0		1	0
		Positive direction		Negative direction	
Reserved	5 to F	Reserved: Setting = 0 (Do not change this setting.)			0

■ Motor Selection (Cn-2A) Settings

SERVOPACK Model	Applicable Motor Model	Cn-2A	Factory Setting
SGDB-02AM	SGM-02A	104	104
	SGMP-02A	124	
SGDB-05AM	SGMG-03A□B	171	142
	SGM-04A	106	
	SGMP-04A	126	
	SGMG-05A□A	142	
SGDB-10AM	SGMG-06A□B	172	143
	SGM-08A	107	
	SGMP-08A	127	
	SGMG-09A□A	143	
	SGMG-09A□B	173	
	SGMS-10A□A	163	
SGDB-15AM	SGMG-12A□B	174	144
	SGMG-13A□A	144	
	SGMP-15A	128	
	SGMS-15A□A	164	
SGDB-20AM	SGMG-20A□A	145	145
	SGMG-20A□B	175	
	SGMS-20A□A	165	

SERVOPACK Model	Applicable Motor Model	Cn-2A	Factory Setting
SGDB-30AM	SGMD-22A□A	155	146
	SGMG-30A□A	146	
	SGMG-30A□B	176	
	SGMS-30A□A	166	
SGDB-50AM	SGMD-32A□A	156	147
	SGMG-44A□A	147	
	SGMG-44A□B	177	
	SGMS-40A□A	167	
	SGMD-40A□A	157	
	SGMS-50A□A	168	
SGDB-60AM	SGMG-55A□A	148	148
	SGMG-60A□B	178	
SGDB-75AM	SGMG-75A□A	149	149
SGDB-1AAM	SGMG-1AA□A	140	140
SGDB-1EAM	SGMG-1EA□A	150	150

■ Output Signal Selection (Cn-2D) Settings

Selects which function signal to output at 1CN.

1's digit	Selects function of 1CN-16, 17 (/BK)
10's digit	Selects function of 1CN-18, 19 (/TGON)
100's digit	Selects function of 1CN 20, 21 (/S-RDY)

Setting	Function
1	/TGON
2	/S-RDY
3	/CLT
4	/BK
5	OL warning
6	OL alarm



■ Function Selection 1 (Cn-32) Settings

Function	Bit No.	Setting		Factory Setting
Reserved	0 to 1	Reserved: Setting = 0 (Do not change this setting.)		0
Change in speed command during automatic operation	2	0	1	0
		Does not use.	Uses.	
Reserved	3	Reserved: Setting = 0 (Do not change this setting.)		0
Soft limit switch	4	0	1	0
		Does not set.	Sets.	
Speed command (automatic operation)	5	0	1	0
		Sets using same method as position command.	Sets using different method from position command.	
Speed command (manual operation)	6	0	1	0
		Sets using same method as position command.	Sets using different method from position command.	
FB when positioning stopped	7	0	1	0
		Motor PG only	According to /LPG contact	
Serial communications group	8	0	1	0
		Does not set.	Sets.	
Addition of axis address to serial response	9	0	1	0
		Does not add.	Adds.	
Echo back when power turned ON	A	0	1	0
		Does not use.	Uses.	
"OK" response to commands	B	0	1	0
		Uses.	Does not use.	
Continuous monitor transmission	C	0	1	0
		Does not use. (Sends once only.)	Uses.	
Variable position loop gain	D	0	1	0
		Does not use.	Uses.	

Function	Bit No.	Setting		Factory Setting
Variable speed loop gain	E	0	1	0
		Does not use.	Uses.	
External positioning function	F	0	1	0
		Does not use.	Uses.	

■ Function Selection 2 (Cn-33) Settings

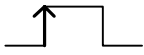
Function	Bit No.	Setting		Factory Setting
STOP signal	0	0	1	0
		Uses.	Does not use.	
Remaining data after STOP signal	1	0	1	0
		Keeps.	Discards.	
Reserved	2	Reserved: Setting = 0 (Do not change this setting.)		0
Station number. 0	3	0	1	0
		Uses.	Does not use.	
Station near signal	4	0	1	0
		Does not use.	Uses.	
Station number output expansion	5	0	1	0
		Does not use.	Uses.	
Reserved	6	Reserved: Setting = 0 (Do not change this setting.)		0
Pulse input	7	0	1	0
		Does not use.	Uses.	
OT signal switching	8	0	1	0
		Standard	Reverses P-OT signal and N-OT signal.	
External position indicator	9	0	1	0
		Does not use.	Uses.	
Zone signal	A	0	1	0
		Does not use.	Uses.	

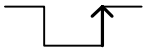
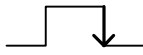
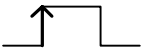
Function	Bit No.	Setting				Factory Setting
		0	1	0	1	
/AST signal logic	B	0	1	0	1	0
	C	0	0	1	1	
Input logic	H L					
/COIN signal interchangeable mode	D	0		1		0
		Software version 001A interchangeable		Software version 0019 or earlier interchangeable		
Line PG	E	0		1		0
		Does not use.		Uses.		
Modification of the positioning-completed signal	F	0		1		0
		Does not use.		Uses.		

C

■ Acceleration/Deceleration Type (Cn-39) Settings

Function	Bit No.	Setting		Factory Setting
Acceleration/deceleration designation	0	0	1	0
		Does not use.	Uses.	
Linear acceleration/deceleration step number	1	0	1	0
		Single-step	Two-step	
S-shaped acceleration/deceleration	2	0	1	0
		Does not use.	Uses.	
Reserved	3 to 7	Reserved: Setting = 0 (Do not change this setting.)		0
Acceleration/deceleration type of automatic operation mode	8	0	1	0
		Linear, S-shaped	Exponential	
Reserved	9	Reserved: Setting = 0 (Do not change this setting.)		0
Acceleration/deceleration type of manual operation mode	A	0	1	0
		Linear, S-shaped	Exponential	
Reserved	B	Reserved: Setting = 0 (Do not change this setting.)		0
Reserved	C	Reserved: Setting = 0 (Do not change this setting.)		0
Reserved	D	Reserved: Setting = 0 (Do not change this setting.)		0
Acceleration/deceleration type of machine zero point return mode	E	0	1	0
		Linear, S-shaped	Exponential	
Reserved	F	Reserved: Setting = 0 (Do not change this setting.)		0

C

D

List of Alarm Displays

SGDB SERVOPACK allows up to 10 last alarms to be displayed at a Digital Operator. This function is called a trace-back function.

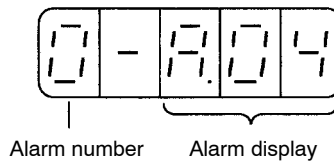

This appendix provides the name and meaning of each alarm display.

For details on how to display an alarm, refer to the following section:
5.2.1 Operation in Alarm Trace-back Mode.

For the cause of each alarm and the action to be taken, refer to the following section: *7.2.1 Troubleshooting Problems with Alarm Display.*

Table D.1. Alarm and Error Displays

Serial Data (Transmitted only in Automatic Transmission Mode)	Status (7-seg- ment LED Display)	Alarm Display on Digital Operator	Alarm Output				/ERR Out- put	Alarm or Error Name	Meaning	Remarks	
			Alarm Code Output								ALM Out- put
			/AL0	/AL1	/AL2	/AL3					
None	This error is not dis- played on 7-segment LED.	This error is not dis- played on the Digital Operator.	OFF	ON	OFF	ON	ON	ON	Mode error	Operation mode setting signal is abnormal.	Only when motor is ON.
			ON	ON	OFF	ON	ON	ON	Position error	Position command data is abnormal (non-existent sta- tion, outside stored stroke limit, etc.)	Only when motor is ON.
			OFF	OFF	ON	ON	ON	ON	Speed error	Command data ex- ceeded speed limit.	Only when motor is ON.
-	-	bb	OFF	OFF	OFF	OFF	ON	OFF	Motor power interrupted	Motor not receiving power.	-
P-OT	P.	Pot	OFF	ON	OFF	OFF	ON	ON	Forward overtravel	Forward overtravel limit switch activated.	-
P-LS	P.	PLS	OFF	OFF	ON	OFF	ON	ON	Forward rotation stored stroke limit	Exceeded forward travel area.	Valid in finite length mode.
N-OT	n.	not	ON	ON	OFF	OFF	ON	ON	Reverse overtravel	Reverse overtravel limit switch activated.	-
N-LS	n.	nLS	ON	OFF	ON	OFF	ON	ON	Reverse rotation stored stroke limit	Exceeded reverse travel area.	Valid in finite length mode.
ERRE1	E.	-	OFF	ON	ON	ON	ON	ON	Communica- tions error	Communications abnormality (parity error, checksum error, etc.)	Only occurs in fixed length mode.
ERRE2	E.	-	OFF	ON	ON	ON	ON	ON	Command error	Undefined command sent.	Only occurs in fixed length mode.

Note: ON: Output transistor is ON
OFF: Output transistor is OFF



◆ Checksum

An automatic check function for a set of data such as parameters. It stores the sum of parameter data, recalculates the sum at specific timing, and then checks whether the stored value matches the recalculated value. This function is a simple method of checking whether a set of data is correct.

Serial Data (Transmitted only in Automatic Transmission Mode)	Status (7-seg- ment LED Dis- play)	Alarm Display on Digital Opera- tor	Alarm Output					/ERR Out- put	Alarm or Error Name	Meaning	Remarks
			Alarm Code Output				ALM Out- put				
			/AL0	/AL1	/AL2	/AL3					
ERRE3	E.	–	OFF	ON	ON	ON	ON	ON	Number error	Input command number out of allowable range.	Only occurs in fixed length mode.
ERRE4	E.	–	OFF	ON	ON	ON	ON	ON	Data error	Command data out of allowable range.	Only occurs in fixed length mode.
ERRE5	E.	–	OFF	ON	ON	ON	ON	ON	Command sum error	Command sum value is incorrect.	Only occurs in fixed length mode.
A.00	0.	A.00	OFF	OFF	OFF	OFF	OFF	OFF	Absolute data alarm	Absolute data fails to be received, or received absolute data is abnormal.	For absolute encoder only
A.02	0.	A.02	OFF	OFF	OFF	OFF	OFF	OFF	EEPROM sum check error	Sum check results of EEPROM are abnormal.	–
A.04	0.	A.04	OFF	OFF	OFF	OFF	OFF	OFF	Parameter setting alarm	The parameter setting is out of the allowable setting range.	–
A.05	0.	A.05	OFF	OFF	OFF	OFF	OFF	OFF	SRAM sum check error	Sum-check results of SRAM are abnormal.	–
A.06	0.	A.06	OFF	OFF	OFF	OFF	OFF	OFF	Back-up data sum check error	Sum-check results of back-up data are abnormal.	–
A.10	1.	A.10	ON	OFF	OFF	OFF	OFF	OFF	Overcurrent	An overcurrent flowed through the power transistor.	–
A.30	3.	A.30	ON	ON	OFF	OFF	OFF	OFF	Regenerative alarm	Regenerative circuit is abnormal.	–
A.40	4.	A.40	OFF	OFF	ON	OFF	OFF	OFF	Main circuit voltage alarm	Main circuit voltage is abnormal.	–
A.51	5.	A.51	ON	OFF	ON	OFF	OFF	OFF	Overspeed	Rotation speed of the motor has exceeded detection level.	Detection level = Maximum rotation speed × 1.1 or × 1.2
A.71	7.	A.71	ON	ON	ON	OFF	OFF	OFF	Overload (high load)	The motor was running for several seconds to several tens of seconds under a torque largely exceeding ratings.	–

Note: ON: Output transistor is ON
OFF: Output transistor is OFF



List of Alarm Displays

Serial Data (Transmitted only in Automatic Transmission Mode)	Status (7-seg- ment LED Display)	Alarm Display on Digital Operator	Alarm Output					/ERR Out- put	Alarm or Error Name	Meaning	Remarks
			Alarm Code Output				ALM Out- put				
			/AL0	/AL1	/AL2	/AL3					
A.72	7.	A.72	ON	ON	ON	OFF	OFF	OFF	Overload (low load)	The motor was running continuously under a torque exceeding ratings.	-
A.7A	7.	A.7A	ON	ON	ON	OFF	OFF	OFF	Heat sink overheat	Heat sink of SERVOPACK overheated.	-
A.80	8.	A.80	OFF	OFF	OFF	ON	OFF	OFF	Encoder zero point alarm	The number of phase-A and phase-B pulses does not match the number of phase-C pulses.	Also detected when using incremental PG.
A.81	8.	A.81	OFF	OFF	OFF	ON	OFF	OFF	Absolute encoder backup alarm	All three power supplies for the absolute encoder (+5 V, battery and internal capacitor) have failed.	For 12 bit absolute encoder only
A.82	8.	A.82	OFF	OFF	OFF	ON	OFF	OFF	Absolute encoder checksum alarm	The checksum results of absolute encoder memory is abnormal.	For 12 bit absolute encoder only
A.83	8.	A.83	OFF	OFF	OFF	ON	OFF	OFF	Absolute encoder battery alarm	Battery voltage for the absolute encoder is abnormal.(Detected by 12-bit absolute encoder.)	For 12 bit absolute encoder only
									Battery voltage drop alarm	Voltage of back-up battery has dropped. (Detected by SERVOPACK.)	-
A.84	8.	A.84	OFF	OFF	OFF	ON	OFF	OFF	Absolute encoder data alarm	Received absolute data is abnormal.	For 12 bit absolute encoder only
A.85	8.	A.85	OFF	OFF	OFF	ON	OFF	OFF	Absolute encoder overspeed	The motor was running at a speed exceeding 400 min ⁻¹ when the absolute encoder was turned ON.	For 12 bit absolute encoder only
A.B0	b.	A.b0	ON	ON	OFF	ON	OFF	OFF	Hardware alarm	Hardware of Servo controller section malfunctioning.	This alarm may not be stored in alarm trace-back memory.

Note: ON: Output transistor is ON
 OFF: Output transistor is OFF

Serial Data (Transmitted only in Automatic Transmission Mode)	Status (7-seg- ment LED Display)	Alarm Display on Digital Operator	Alarm Output					/ERR Out- put	Alarm or Error Name	Meaning	Remarks
			Alarm Code Output				ALM Out- put				
			/AL0	/AL1	/AL2	/AL3					
A.B2	b.	A.b2	ON	ON	OFF	ON	OFF	OFF	CPU error 1	CPU of SERVO- PACK malfunction- ing.	*
A.B3	b.	A.b3	ON	ON	OFF	ON	OFF	OFF	CPU error 2		
A.C1	C.	A.C1	OFF	OFF	ON	ON	OFF	OFF	Servo overrun alarm	The servomotor (encoder) overrun.	-
A.C2	C.	A.C2	OFF	OFF	ON	ON	OFF	OFF	Encoder phase error detection alarm	Phase -A, -B and -C output by the encoder are abnormal.	For incremen- tal encoder only.
A.C3	C.	A.C3	OFF	OFF	ON	ON	OFF	OFF	Encoder phase-A, -B disconnection	Wiring in encoder phase-A or -B is disconnected.	-
A.C4	C.	A.C4	OFF	OFF	ON	ON	OFF	OFF	Encoder phase-C disconnection	Wiring in encoder phase-C is disconnected.	-
A.D0	d.	A.d0	ON	OFF	ON	ON	OFF	OFF	Position error pulse overflow	Position error pulse has exceeded the “Overflow” parameter setting.	-
A.F1	F.	A.F1	ON	ON	ON	ON	OFF	OFF	Power lines open phase detect	One phase is not connected in the main power supply.	-
A.F3	F.	A.F3	ON	ON	ON	ON	OFF	OFF	Power loss error	A power loss exceeding one cycle occurred in AC power supply.	Only when bit 5 of Cn-01 set to 1
-	Undefined	CPF00	Undefined				OFF	Unde- fined	Digital Operator transmission error 1	Digital Operator fails to communi- cate with SERVOPACK even five seconds after power is turned ON.	These alarms are not stored in alarm trace- back memory.
-	Undefined	CPF01	Undefined				OFF	Unde- fined	Digital Operator transmission error 2	Transmission error has occurred five consecutive times.	
-	-. or .	A.99	OFF	OFF	OFF	OFF	ON	OFF	Not an alarm	Normal operation status	-
Indeterminate or no transmis- sion		Undefined	OFF	OFF	OFF	OFF	OFF	OFF	Control board alarm	Control board faulty.	-

Note: ON: Output transistor is ON
OFF: Output transistor is OFF

* Serial data (automatic transmission) and alarm output may be uncertain, and the 7-segment LED may display the symbol . In such cases, either A.B2 or A.B3 will be stored in the alarm trace-back memory. (In the Digital Operator, “B2” and “B3” will be displayed as “b2” and “b3.”)



E

Supplementary Information on SGDB-□□AMA SERVOPACKs (Contact I/O with Reverse Common)

The SGDB-□□AMA source output uses +24 V common as contact input and 0 V common as contact output, which is the reverse of the SGDB-□□AM SERVOPACK described in this manual. This appendix explains the differences between the SGDB-□□AMA and SGDB-□□AM SERVOPACKs.

E.1	List of I/O Signals	E - 3
E.2	Lists of 6CN I/O Signals by Command Mode	E - 5
E.3	Contact I/O Circuits	E - 12
E.4	Wiring Examples	E - 14

Some SGDB-□□AMA terminals have identical specifications to those of the SGDB-□□AM SERVOPACK. Other contact I/O and their common terminals are connected in the reverse order of those of the SGDB-□□AM described in this manual.

For SGDB-□□AMA contacts, it is necessary to understand the explanation given for SGDB-□□AM as shown below. For details, refer to the lists of signals.

Classifications in SGDB-□□AMA I/O Signal List	Explanation	For SGDB-□□AM	For SGDB-□□AMA
Group of contact output terminals for which the terminals of each contact I/O are independent and there are no common terminals (output terminals X+, X-).	Operation: Since the polarity of the contact I/O drive power supply is reversed, the operating logic is reversed.	ON state: The circuit between X+ and X- is closed, and X+ is at low level.	ON state: The circuit between X+ and X- is closed, and X- is at high level.
		OFF state: The circuit between X+ and X- is open, and X+ is at high level.	OFF state: The circuit between X+ and X- is open, and X- is at low level.
	Signal name: Since the operating logic is reversed, the logic indicating the signal names is reversed.	Example: /BK+ /BK- ALM+ ALM-	Example: BK+ BK- /ALM+ /ALM-
Group of contact I/O terminals which have a common terminal for each group. Common terminal is Y (input or output terminal X,Y).	Operation: Since the polarity of the contact I/O drive power supply is reversed, the operating logic is reversed.	ON state: X is at low level.	ON state: X is at high level.
		OFF state: X is at high level.	OFF state: X is at low level.
	Signal name: Since the operating logic is reversed, the logic indicating the signal names is reversed. The polarity of the power supply connected to common terminals is reversed also.	Example: /AUT-LT /AL0 /S-ON STP /CD0 STOP 0V1 +24V	Example: AUT-LT AL0 S-ON /STP CD0 /STOP +24V1 0V
Terminals not mentioned above	Signal names and functions are the same as those of model SGDB-□□AM.		

E

E.1 List of I/O Signals

Lists of SGDB-□□AMA I/O signals are provided below.

■ List of SGDB-□□AMA 1CN I/O Signals

List of 1CN I/O Signals

According to parameter settings, the specifications of some signal terminals on connector 1CN vary.

1CN Terminal No.	Symbol	Signal Name	Relevant Circuit Diagram	1CN Terminal No.	Symbol	Signal Name	Relevant Circuit Diagram
1	–	–	–	19	TGON+	Rotation detection output *3, *5	1CN output circuit
2	SG	Signal ground	–	20	S-RDY+	Servo ready output *3, *5	1CN output circuit
3	PULS	Command pulse, line PG pulse phase-A input*1	–	21	S-RDY-		
4	/PULS		–	22	/ALM+	Servo alarm output *5	1CN output circuit
5	SG	Signal ground	–	23	/ALM-		
6	SIGN	Command pulse, line PG pulse phase-B or sign input	–	24	PAO	PG division output phase A	–
7	/SIGN		–	25	/PAO		
8	–	–	–	26	PBO	PG division output phase B	–
9	/CC	Line PG machine zero point pulse input	–	27	/PBO		
10	CC		–	28	S-ON	Servo ON input *4	1CN input circuit
11	TMON	Torque monitor output *2	–	29	P-CON	Proportional control command input *4	1CN input circuit
12	VTG	Speed monitor output *2	–	30	/P-OT	Forward drive prohibited input *4	1CN input circuit
13	–	–	–	31	/N-OT	Reverse drive prohibited input *4	1CN input circuit
14	PCO	PG division output phase C	–	32	/STP	Machine zero point return limit switch input *4	1CN input circuit
15	/PCO		–	33	P-CL	Forward torque limit input *4	1CN input circuit
16	BK+	Break interlock output *3, *5	1CN output circuit	34	N-CL	Reverse torque limit input *4	1CN input circuit
17	BK-			35	0 V	0 V external power supply input *4	1CN input circuit
18	TGON+	Rotation detection output *3, *5	1CN output circuit	36	–	–	–

* 1. Specification changes according to bit E of Cn-33 and bits 3, 4, and 5 of Cn-02. Refer to *Line PG and Pulse Input Terminals* (page B-3), or *Appendix C*.

- * 2. Specification changes according to bits 6 and 7 of Cn-02. Refer to specifications stated in *Analog Monitor Signals* (page B -3).
- * 3. Specification changes according to setting of Cn-2D. Refer to *Appendix C* (page C -11).
- * 4. For the SGDB-□□AMA, understand the explanation given in the SGDB-□□AM manual as follows:

	SGDB-□□AM	SGDB-□□AMA
Input terminal X, common terminal Y	ON state: X is at low level.	ON state: X is at high level.
	OFF state: X is at high level.	OFF state: X is at low level.
	Example: /AUT-LT, /AL0, /S-ON, STP, /CD0, STOP	Example: AUT-LT, AL0, S-ON, /STP, CD0, /STOP

- * 5. For the SGDB-□□AMA, understand the explanation given in the SGDB-□□AM manual as follows:

	SGDB-□□AM	SGDB-□□AMA
Output terminal X+, X-	ON state: The circuit between X+ and X- is closed, and X+ is at low level.	ON state: The circuit between X+ and X- is closed, and X+ is at high level.
	OFF state: The circuit between X+ and X- is open, and X+ is at high level.	OFF state: The circuit between X+ and X- is open, and X+ is at low level.
	Example: /BK+, /BK-, ALM+, ALM-	Example: BK+, BK-, /ALM+, /ALM-

E

E.2 Lists of 6CN I/O Signals by Command Mode

Lists of SGDB-□□AMA 6CN I/O signals in each command mode are provided below.

■ List of 6CN I/O Signals in Station Number Method

Table E.1. Station Number Command Method (Cn-27 = 0)

1CN Terminal No.	Symbol	Signal Name	Relevant Circuit Diagram	1CN Terminal No.	Symbol	Signal Name	Relevant Circuit Diagram
1	+24 V	+24 V input 1	6CN output circuit	26	+24V2	+24 V input 2	6CN output circuit
2	AUT-LT	Automatic operation mode output	6CN output circuit	27	ERR	Command error output	6CN output circuit
3	MAN-LT	Manual operation mode output	6CN output circuit	28	P0	Current station position output 1	6CN output circuit
4	POS1	Positioning completed output (COIN)	6CN output circuit	29	P1	Current station position output 2	6CN output circuit
5	POS2	Positioning near output (NEAR)	6CN output circuit	30	P2	Current station position output 3	6CN output circuit
6	AL0	Alarm code output 1	6CN output circuit	31	P3	Current station position output 4	6CN output circuit
7	AL1	Alarm code output 2	6CN output circuit	32	P4	Current station position output 5	6CN output circuit
8	AL2	Alarm code output 4	6CN output circuit	33	CD0	Command data input 0	6CN input circuit
9	AL3	Alarm code output 8	6CN output circuit	34	CD1	Command data input 1	6CN input circuit
10	-	-	-	35	CD2	Command data input 2	6CN input circuit
11	-	-	-	36	CD3	Command data input 3	6CN input circuit
12	-	-	-	37	CD4	Command data input 4	6CN input circuit
13	ZRN	Machine zero point return mode setting input	6CN input circuit	38	CD5	Command data input 5	6CN input circuit
14	MAN	Manual operation mode setting input	6CN input circuit	39	CD6	Command data input 6	6CN input circuit
15	PULS	Pulse operation mode setting input	6CN input circuit	40	CD7	Command data input 7	6CN input circuit
16	MCW	Manual operation input (reverse)	6CN input circuit	41	CD8	Command data input 8	6CN input circuit
17	MCCW	Manual operation input (forward)	6CN input circuit	42	CD9	Command data input (9)	6CN input circuit
18	RST	Reset input	6CN input circuit	43	CD10	Command data input (10)	6CN input circuit

1CN Terminal No.	Symbol	Signal Name	Relevant Circuit Diagram	1CN Terminal No.	Symbol	Signal Name	Relevant Circuit Diagram
19	SP2ND	Speed selection code input 2	6CN input circuit	44	CD11	Command data input (11)	6CN input circuit
20	SP3RD	Speed selection code input 3	6CN input circuit	45	DR0	Rotating direction select input 1	6CN input circuit
21	LPG	Line PG selection input	6CN input circuit	46	DR1	Rotating direction select input 2	6CN input circuit
22	AST	Start command input	6CN input circuit	47	PS0	Station number read select input 0	6CN input circuit
23	ALMRST	Alarm reset input	6CN input circuit	48	PS1	Station number read select input 1	6CN input circuit
24	/STOP	Pause input	6CN input circuit	49	0V2	0 V input 2	6CN input circuit
25	0V1	0 V input 1	6CN input circuit	50	–	–	–

Note: For the SGDB-□□AMA, understand the explanation given in the SGDB-□□AM manual as follows:

	SGDB-□□AM	SGDB-□□AMA
Input or output terminal X, common terminal Y	ON state: X is at low level. OFF state: X is at high level.	ON state: X is at high level. OFF state: X is at low level.
	Example: /AUT-LT, /AL0, /CD0, STOP	Example: AUT-LT, AL0, CD0, /STOP

E

■ List of 6CN I/O Signals in Digital Switch Method

Table E.2. Digital Switch Command Method (Cn-27 = 1)

1CN Terminal No.	Symbol	Signal Name	Relevant Circuit Diagram	1CN Terminal No.	Symbol	Signal Name	Relevant Circuit Diagram
1	+24 V	+24 V input 1	6CN output circuit	26	+24V2	+24 V input 2	6CN output circuit
2	AUT-LT	Automatic operation mode output	6CN output circuit	27	ERR	Command error output	6CN output circuit
3	MAN-LT	Manual operation mode output	6CN output circuit	28	DSO0	Data strobe output 0	6CN output circuit
4	POS1	Positioning completed output (COIN)	6CN output circuit	29	DSO1	Data strobe output 1	6CN output circuit
5	POS2	Positioning near output (NEAR)	6CN output circuit	30	DSO2	Data strobe output 2	6CN output circuit
6	AL0	Alarm code output 1	6CN output circuit	31	DSO3	Data strobe output 3	6CN output circuit
7	AL1	Alarm code output 2	6CN output circuit	32	DSO4	Data strobe output 4	6CN output circuit
8	AL2	Alarm code output 4	6CN output circuit	33	DSI10	Position data input 0	6CN input circuit
9	AL3	Alarm code output 8	6CN output circuit	34	DSI11	Position data input 1	6CN input circuit
10	-	-	-	35	DSI12	Position data input 2	6CN input circuit
11	-	-	-	36	DSI13	Position data input 3	6CN input circuit
12	-	-	-	37	DSI14	Position data input 4	6CN input circuit
13	ZRN	Zero point return mode setting input	6CN input circuit	38	DSI15	Position data input 5	6CN input circuit
14	MAN	Manual operation mode setting input	6CN input circuit	39	DSI16	Position data input 6	6CN input circuit
15	PULS	Pulse operation mode setting input	6CN input circuit	40	DSI17	Position data input 7	6CN input circuit
16	MCW	Manual operation input (reverse)	6CN input circuit	41	DSI20	Speed data input 0	6CN input circuit
17	MCCW	Manual operation input (forward)	6CN input circuit	42	DSI21	Speed data input 1	6CN input circuit
18	RST	Reset input	6CN input circuit	43	DSI22	Speed data input 2	6CN input circuit
19	SP2ND	Speed selection code input 2	6CN input circuit	44	DSI23	Speed data input 3	6CN input circuit
20	SP3RD	Speed selection code input 3	6CN input circuit	45	DSI24	Speed data input 4	6CN input circuit

1CN Terminal No.	Symbol	Signal Name	Relevant Circuit Diagram	1CN Terminal No.	Symbol	Signal Name	Relevant Circuit Diagram
21	LPG	Line PG selection input	6CN input circuit	46	DSI25	Speed data input 5	6CN input circuit
22	AST	Start command input	6CN input circuit	47	DSI26	Speed data input 6	6CN input circuit
23	ALMRST	Alarm reset input	6CN input circuit	48	DSI27	Speed data input 7	6CN input circuit
24	/STOP	Pause input	6CN input circuit	49	0V2	0 V input 2	6CN input circuit
25	0V1	0 V input 1	6CN input circuit	50	–	–	–

Note: For the SGDB-□□AMA, understand the explanation given in the SGDB-□□AM manual as follows:

	SGDB-□□AM	SGDB-□□AMA
Input or output terminal X, common terminal Y	ON state: X is at low level. OFF state: X is at high level.	ON state: X is at high level. OFF state: X is at low level.
	Example: /AUT-LT, /AL0, /DSI10, STOP	Example: AUT-LT, AL0, DSI10, /STOP

■ List of 6CN I/O Signals in Serial Communications Method

Table E.3. Serial Communications Method (Cn-27 = 2)

1CN Terminal No.	Symbol	Signal Name	Relevant Circuit Diagram	1CN Terminal No.	Symbol	Signal Name	Relevant Circuit Diagram
1	+24 V	+24 V input 1	6CN output circuit	26	+24V2	+24 V input 2	6CN output circuit
2	AUT-LT	Automatic operation mode output	6CN output circuit	27	ERR	Command error output	6CN output circuit
3	MAN-LT	Manual operation mode output	6CN output circuit	28	P0	Zone signal output 1	6CN output circuit
4	POS1	Positioning completed output (COIN)	6CN output circuit	29	P1	Zone signal output 2	6CN output circuit
5	POS2	Positioning near output (NEAR)	6CN output circuit	30	P2	Zone signal output 3	6CN output circuit
6	AL0	Alarm code output 1	6CN output circuit	31	P3	Zone signal output 4	6CN output circuit
7	AL1	Alarm code output 2	6CN output circuit	32	P4	Zone signal output 5	6CN output circuit
8	AL2	Alarm code output 4	6CN output circuit	33	–	–	–
9	AL3	Alarm code output 8	6CN output circuit	34	–	–	–

1CN Terminal No.	Symbol	Signal Name	Relevant Circuit Diagram	1CN Terminal No.	Symbol	Signal Name	Relevant Circuit Diagram
10	-	-	-	35	-	-	-
11	-	-	-	36	-	-	-
12	-	-	-	37	-	-	-
13	ZRN	Machine zero point return mode setting input	6CN input circuit	38	-	-	-
14	MAN	Manual operation mode setting input	6CN input circuit	39	-	-	-
15	PULS	Pulse operation mode setting input	6CN input circuit	40	-	-	-
16	MCW	Manual operation input (reverse)	6CN input circuit	41	-	-	-
17	MCCW	Manual operation input (forward)	6CN input circuit	42	-	-	-
18	RST	Reset input	6CN input circuit	43	-	-	-
19	SP2ND	Speed selection code input 2	6CN input circuit	44	-	-	-
20	S[3RD	Speed selection code input 3	6CN input circuit	45	-	-	-
21	LPG	Line PG selection input	6CN input circuit	46	-	-	-
22	AST	Start command input	6CN input circuit	47	-	-	-
23	ALMRST	Alarm reset input	6CN input circuit	48	-	-	-
24	/STOP	Pause input	6CN input circuit	49	-	-	-
25	0V1	0 V input 1	6CN input circuit	50	-	-	-

Note: For the SGDB-□□AMA, understand the explanation given in the SGDB-□□AM manual as follows:

	SGDB-□□AM	SGDB-□□AMA
Input or output terminal X, common terminal Y	ON state: X is at low level. OFF state: X is at high level.	ON state: X is at high level. OFF state: X is at low level.
	Example: /AUT-LT, /AL0, /P0, STOP	Example: AUT-LT, AL0, P0, /STOP



■ List of 6CN I/O Signals in Command Table Method

Table E.4. Command Table Method (Cn-27 = 4)

1CN Terminal No.	Symbol	Signal Name	Relevant Circuit Diagram	1CN Terminal No.	Symbol	Signal Name	Relevant Circuit Diagram
1	+24 V	+24 V input 1	6CN output circuit	26	+24V2	+24 V input 2	6CN output circuit
2	AUT-LT	Automatic operation mode output	6CN output circuit	27	ERR	Command error output	6CN output circuit
3	MAN-LT	Manual operation mode output	6CN output circuit	28	P0	Zone signal output 1	6CN output circuit
4	POS1	Positioning completed output (COIN)	6CN output circuit	29	P1	Zone signal output 2	6CN output circuit
5	POS2	Positioning near output (NEAR)	6CN output circuit	30	P2	Zone signal output 3	6CN output circuit
6	AL0	Alarm code output 1	6CN output circuit	31	P3	Zone signal output 4	6CN output circuit
7	AL1	Alarm code output 2	6CN output circuit	32	P4	Zone signal output 5	6CN output circuit
8	AL2	Alarm code output 4	6CN output circuit	33	CD0	Position number data input 0	6CN input circuit
9	AL3	Alarm code output 8	6CN output circuit	34	CD1	Position number data input 1	6CN input circuit
10	–	–	–	35	CD2	Position number data input 2	6CN input circuit
11	–	–	–	36	CD3	Position number data input 3	6CN input circuit
12	–	–	–	37	CD4	Position number data input 4	6CN input circuit
13	ZRN	Zero point return mode setting input	6CN input circuit	38	CD5	Position number data input 5	6CN input circuit
14	MAN	Manual operation mode setting input	6CN input circuit	39	CD6	Position number data input 6	6CN input circuit
15	PULS	Pulse operation mode setting input	6CN input circuit	40	CD7	Position number data input 7	6CN input circuit
16	MCW	Manual operation input (reverse)	6CN input circuit	41	CD8	Position number data input 8	6CN input circuit
17	MCCW	Manual operation input (forward)	6CN input circuit	42	–	–	–
18	RST	Reset input	6CN input circuit	43	–	–	–
19	SP2ND	Speed selection code input 2	6CN input circuit	44	–	–	–
20	SP3RD	Speed selection code input 3	6CN input circuit	45	–	–	–

1CN Terminal No.	Symbol	Signal Name	Relevant Circuit Diagram	1CN Terminal No.	Symbol	Signal Name	Relevant Circuit Diagram
21	LPG	Line PG selection input	6CN input circuit	46	-	-	-
22	AST	Start command input	6CN input circuit	47	PS0	Zone signal read selection input 0	6CN input circuit
23	ALMRST	Alarm reset input	6CN input circuit	48	PS1	Zone signal read selection input 1	6CN input circuit
24	/STOP	Pause input	6CN input circuit	49	0V2	0 V input 2	6CN input circuit
25	0V1	0 V input 1	6CN input circuit	50	-	-	-

Note: For the SGDB-□□AMA, understand the explanation given in the SGDB-□□AM manual as follows:

	SGDB-□□AM	SGDB-□□AMA
Input or output terminal X, common terminal Y	ON state: X is at low level. OFF state: X is at high level.	ON state: X is at high level. OFF state: X is at low level.
	Example: /AUT-LT, /AL0, /CD0, STOP	Example: AUT-LT, AL0, CD0, /STOP



E.3 Contact I/O Circuits

The contact I/O circuits of the SGDB-□□AMA SERVOPACK are shown below.

■ 1CN Input Circuit

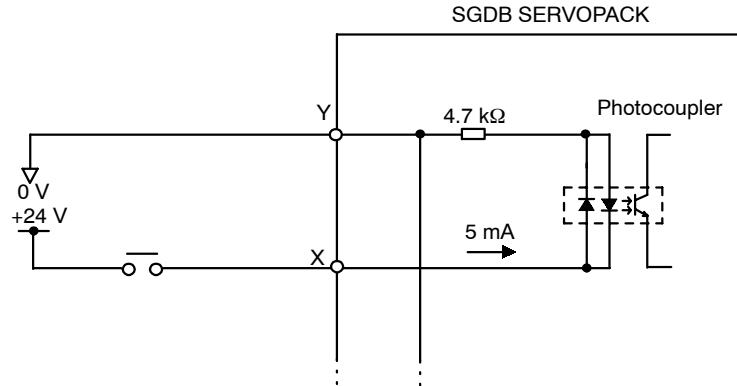

■ 1CN Output Circuit

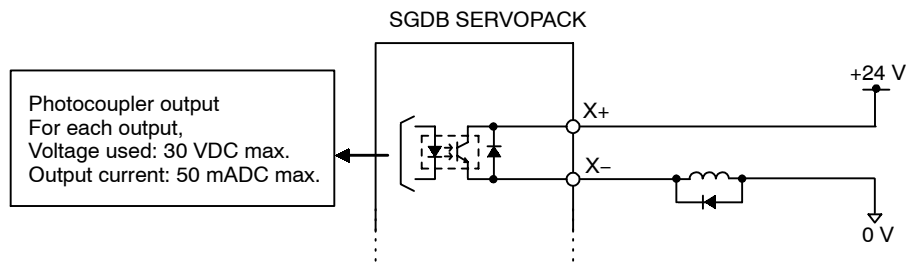

■ 6CN Input Circuit

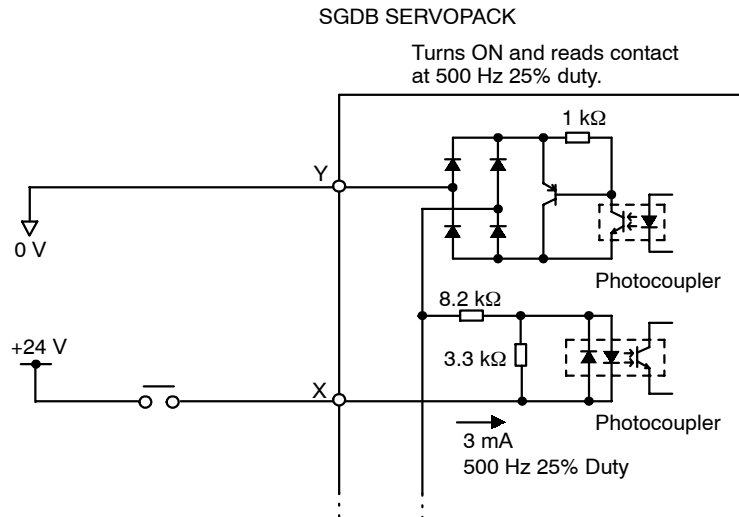

■ 6CN Output Circuit

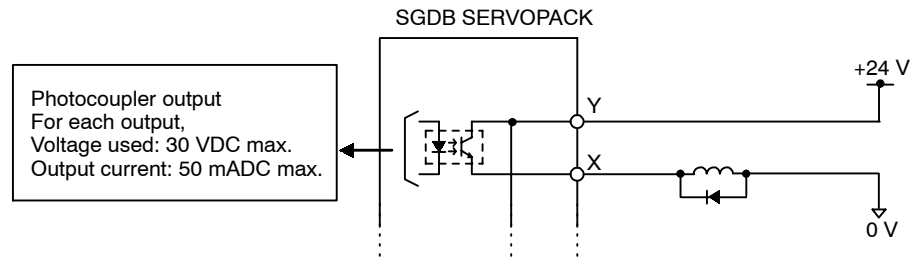

E.4 Wiring Examples

The following are examples of wiring the SGDB-□□AMA in each command method.

E

Station Number Method Wiring Example

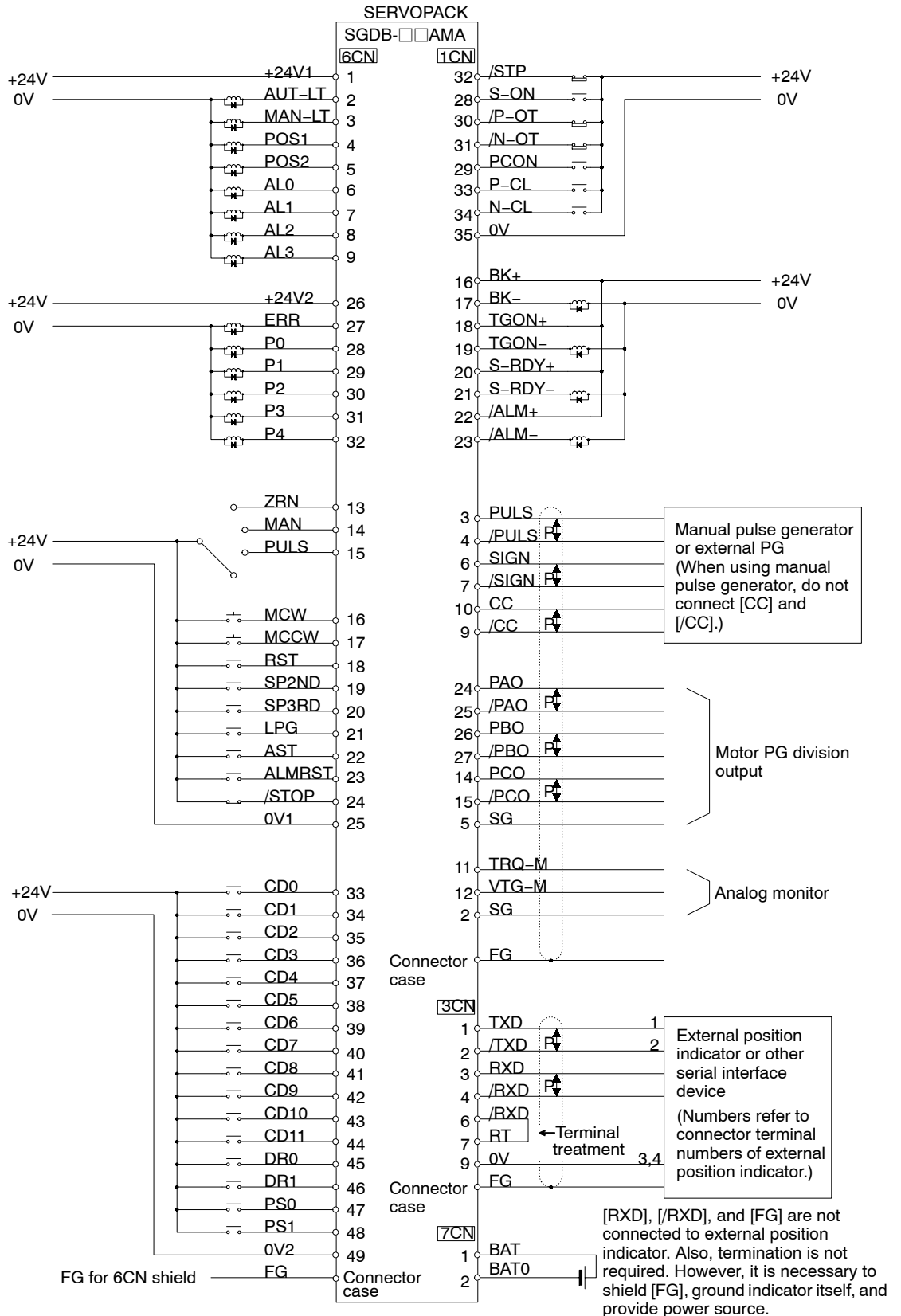

■ Digital Switch Method Wiring Example

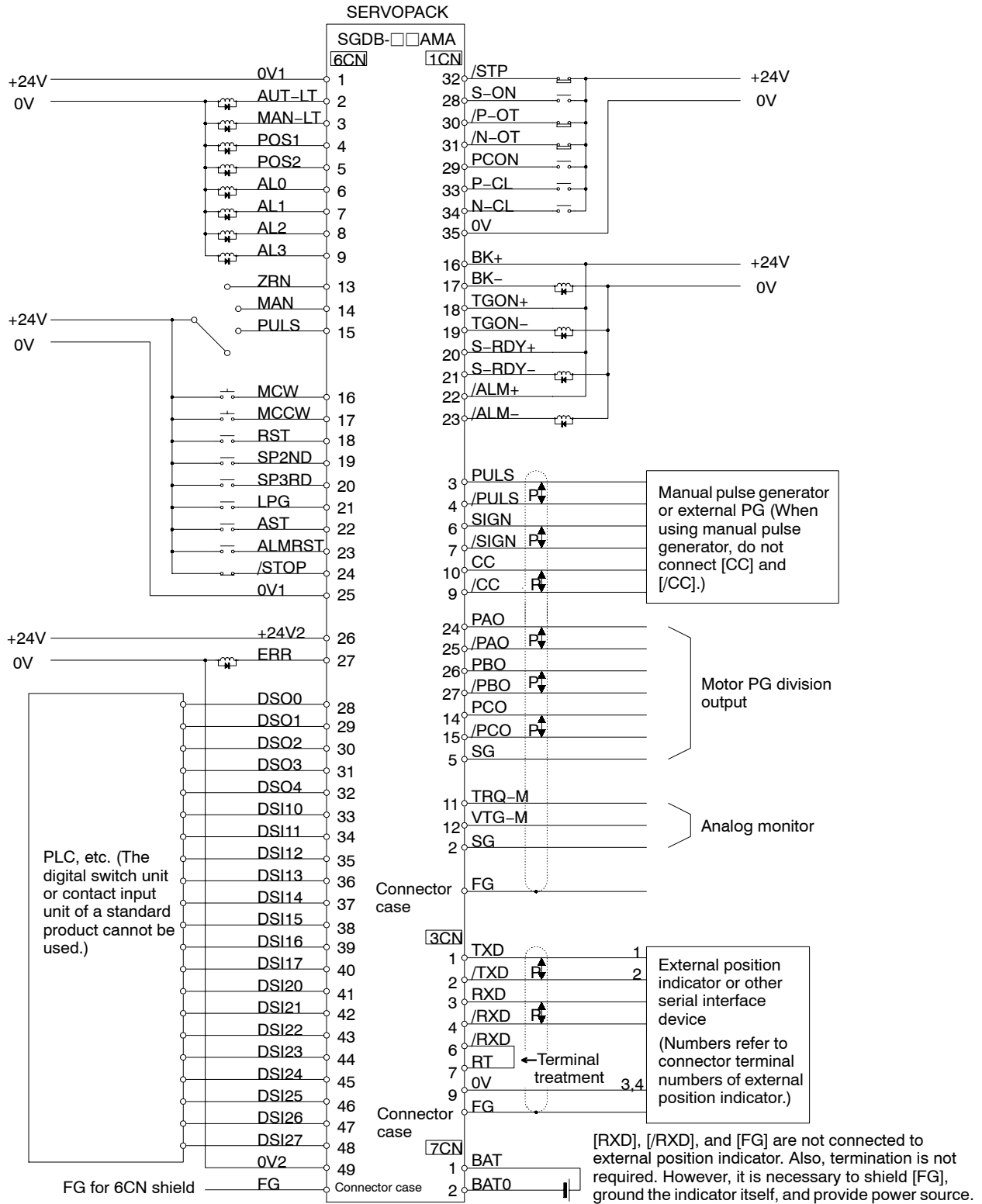

Note: Since the polarity of the contact I/O drive power supply is reversed, the Digital Switch Unit and Contact Input Unit of an SGDB-□□AM SERVOPACK cannot be used. Yaskawa does not supply Digital Switch Units or Contact Input Units for the SGDB-□□AMA SERVOPACK.

Serial Communications Method Wiring Example

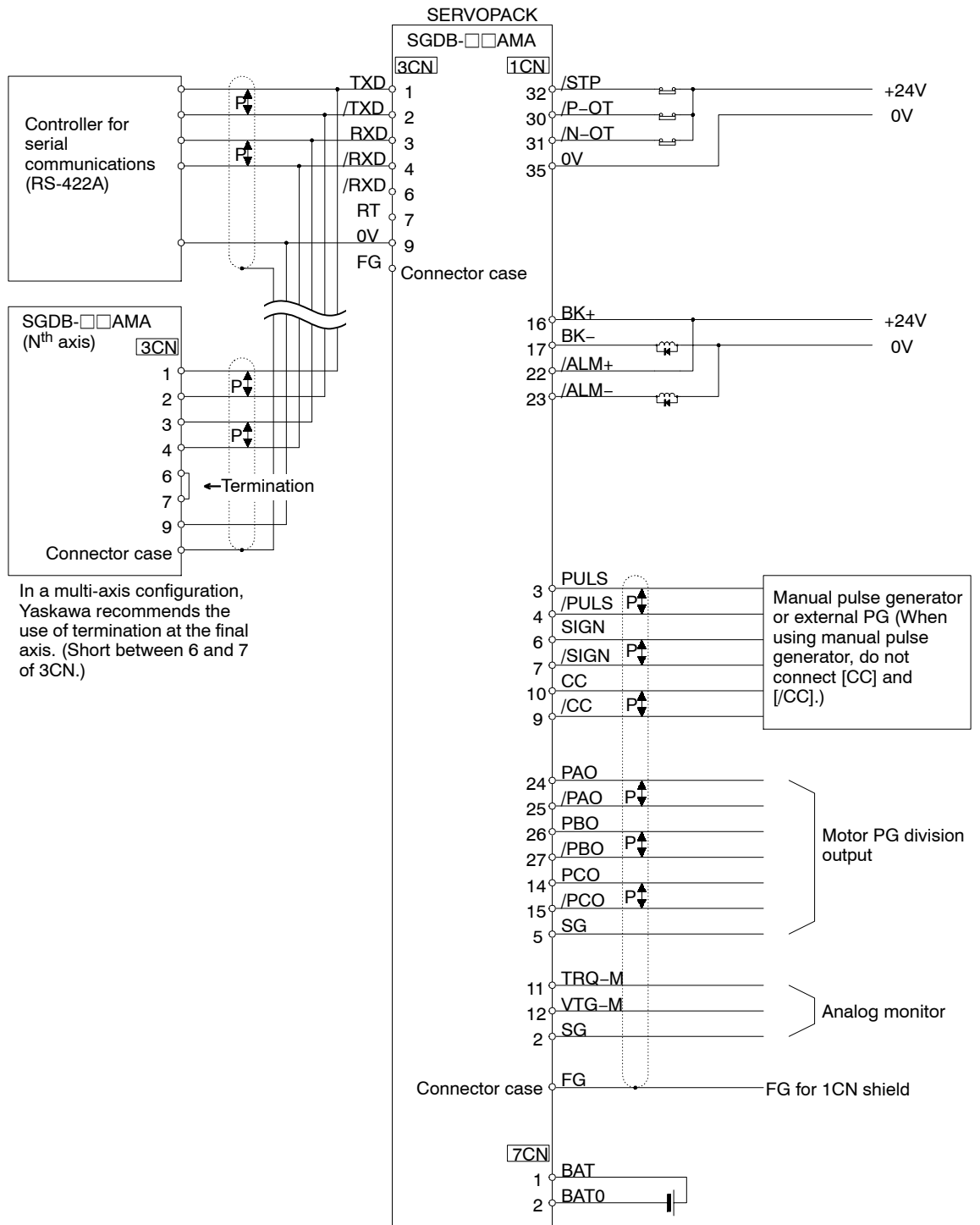

Command Table Method Wiring Example

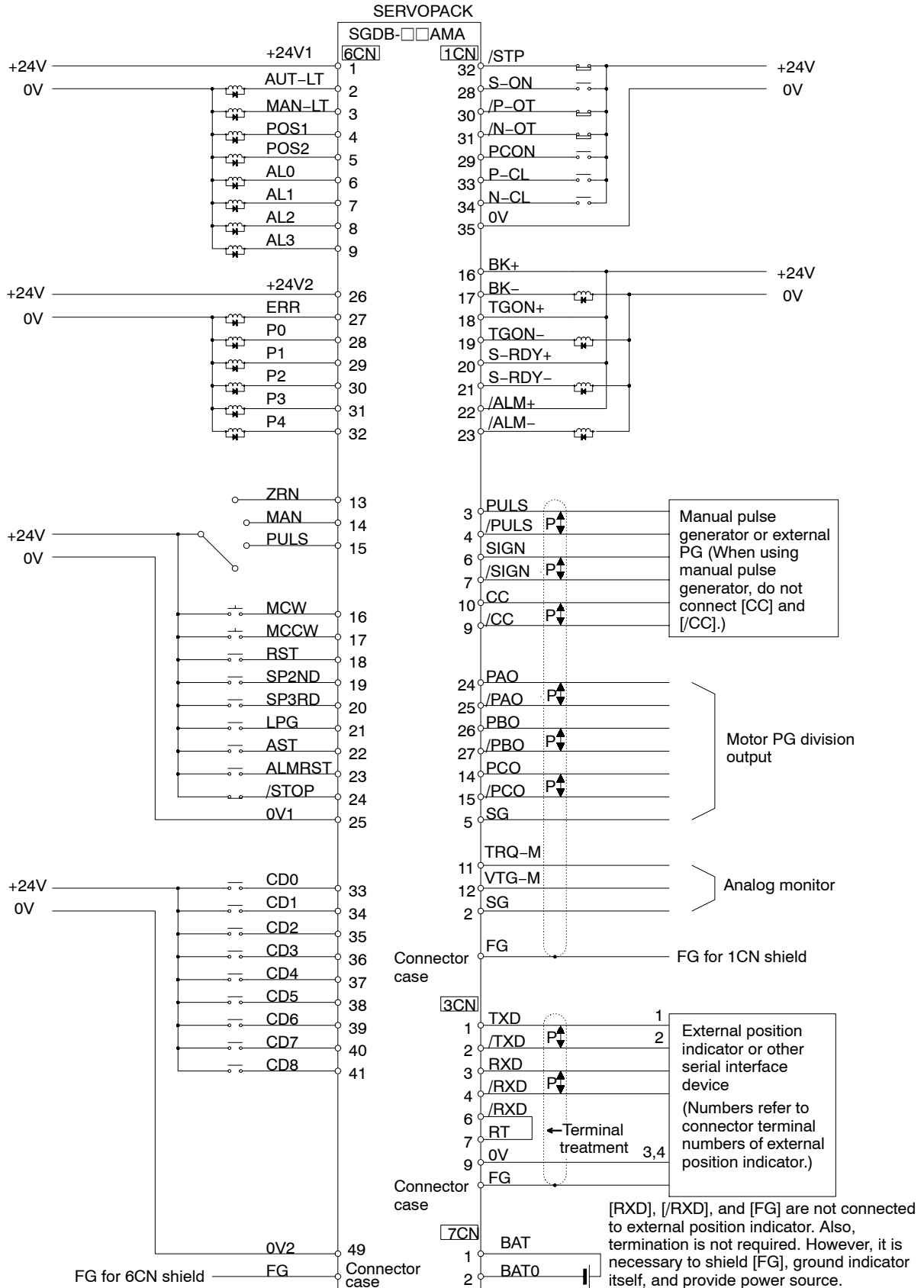

INDEX

A

- absolute value detection system, 3 -134
- alarm traceback data, clearing, 5 -36
- alarms
 - display, troubleshooting, 7 -5
 - Servo, resetting using Digital Operator, 5 -4
 - servo, reset, 5 -4
- alignment, 2 -8
 - radial load, 2 -8
 - thrust load, 2 -8
- autotuning, 5 -33
 - adjustment of position control SERVOPACKs, A -4
- autotuning function, 3 -118
 - Digital Operators, 5 -33

B

- battery, replacement, absolute encoder, 7 -4
- brake power supply, 2 -14
 - dimensional drawings, 6 -216
 - internal circuit, 6 -217
 - specifications, 6 -216

C

- cables, 3 -125
 - encoders
 - dimensional drawings, 6 -218
 - specifications, 6 -218
 - for connecting PC and SERVOPACK, 6 -256
 - motor, connectors, 6 -212
 - specifications, 6 -190
 - tension, 3 -125
- command pulse, input
 - allowable voltage level, 3 -99
 - timing, 3 -99
- connector kits, 6 -195
 - dimension drawings, 6 -195
 - specifications, 6 -195

connectors

- 1CN, test run, 2 -24
- absolute encoder, 3 -147, 3 -149
- Digital Operator, 3 -154
- encoder cables, 6 -211
- incremental encoder, 3 -146, 3 -148
- motor cables, 6 -212
- Servomotors with holding brake, 6 -130
 - IP67-based, 6 -135
- Servomotors without holding brake, 6 -127
- standard motor with brake, 3 -151, 3 -153
- standard motor without brake, 3 -150, 3 -152
- terminal layouts, 3 -141
- SERVOPACK, 3 -141

controlled systems

- components, 1 -6
- meaning, 1 -5
- current detection offset, manual adjustment mode, 5 -40

D

- deceleration stop mode, 3 -27
- detectors
 - encoders, 1 -8
 - meaning, 1 -5
- Digital Operator, 2 -15
- Digital Operators
 - autotuning, 5 -30
 - connection, 5 -2
 - dimensional drawings, 6 -149
 - selection, 6 -17
 - flowchart, 6 -18
 - servo alarm reset, 5 -4
- dimensional drawings, 6 -55
 - brake power supply, 6 -216
 - cables, encoders, 6 -218
 - connector kits, 6 -195
 - Digital Operators, 6 -149
 - magnetic contactor, 6 -243
 - regenerative resistor unit, 6 -246
 - Servomotors, 6 -55
 - SERVOPACKs, 6 -138
- dividing, 3 -104
- drive systems, 1 -6
- dynamic brake, 3 -111
 - stop mode, 3 -28

E

- electronic gear function, 3 -9
 - setting, 3 -9
- electronic gear ratio, 3 -9
 - command unit, 3 -9
 - for different load mechanisms, 3 -11
 - load travel distance per revolution of load shaft in command units, 3 -9
 - machine specifications, 3 -9
- encoder output, 3 -104
 - signals, divided, 3 -104
- encoder pulses, number per revolution, 3 -6
- encoders
 - absolute, 1 -8, 3 -134
 - battery replacement, 7 -4
 - cables
 - connectors, 6 -211
 - dimensional drawings, 6 -218
 - specifications, 6 -218
 - extending cables, 3 -137
 - incremental, 1 -8
- external torque limit, 3 -16
- external torque limit input, 3 -18
 - forward, 3 -18
 - reverse, 3 -18

F

- feed-forward control, 3 -119
- feedback control, meaning, 1 -3
- fuse, 3 -126

G

- gain
 - adjustment, 3 -115
 - AC SERVOPACK, A -2
 - setting references, load inertia ratio, A -8
- ground-fault interrupter, 2 -3
- grounding, 2 -3
 - wiring, 3 -127

H

- high-voltage lines, SERVOPACKs, 3 -140
- holding brake, 3 -112
 - electrical specifications, 200-VAC SGM Servomotors, 6 -21, 6 -25, 6 -29, 6 -35
- host controllers, 1 -5, 1 -9
- hot start, 6 -52

I

- impact resistance, 6 -43
- input signal terminals
 - forward external torque limit input, 3 -17
 - reverse external torque limit input, 3 -17
 - servo ON, 3 -21
- inspection, 7 -2, 7 -3
 - Servomotors, 7 -2
 - SERVOPACKs, 7 -3
- installation, 2 -4
 - servomotor, alignment, 2 -8
 - Servomotors, 2 -7
 - SERVOPACKs, 2 -10
- internal torque limit, 3 -16

L

- limit switch, overtravel limit function, 3 -25
- load inertia, gain settings, A -8
- loads
 - allowable radial load, 6 -41
 - allowable thrust load, 6 -41

M

- machine data table, 6 -11
- machine rigidity, 5 -33
 - selection, 5 -30
- magnetic contactor, 2 -14
 - dimensional drawings, 6 -243
 - specifications, 6 -243
- maintenance, 7 -2, 7 -3
 - Servomotors, 7 -2
 - SERVOPACKs, 7 -3
- mechanical tolerance, 6 -42
- memory switches, 3 -4

mode switch, 3 -120
 detection points
 error pulse, 3 -123
 motor acceleration, 3 -122
 speed command, 3 -122
 torque command, 3 -121

molded-case circuit breaker (MCCB), 2 -14, 3 -126, 6 -241

N

noise control, 2 -3
 filter, 2 -14, 3 -125
 installation, 3 -128
 wiring, 3 -126

O

order lists, 6 -165

output phase, form, 3 -105
 absolute encoder, 3 -105
 incremental encoder, 3 -105

output signal terminals
 brake interlock output, 3 -112
 encoder output, 3 -105
 overload alarm, 3 -45
 overload warning, 3 -45
 running output, 3 -43

overhanging load
 precautions, 2 -3
 Servomotors, 6 -54

overload
 alarm, 3 -45
 characteristics, SERVOPACKs, 6 -52
 warning, 3 -45

overtravel limit function, 3 -25

P

parameter, 3 -8, 3 -26
 bias, 3 -119
 brake signal output timing during motor operation, 3 -114
 brake signal speed level output during motor operation, 3 -114
 dividing ratio setting, 3 -105
 encoder type selection, 3 -6
 feed-forward gain, 3 -119
 forward external torque limit, 3 -17
 motor selection, 3 -5

number of encoder pulses, 3 -6, 3 -135
 operation when motor stops after overtravel, 3 -27
 operation when motor stops after servo OFF, 3 -28
 output signal selection, 3 -43, 3 -44, 3 -45, 3 -113
 overflow, 3 -115
 position loop gain, 3 -115
 positioning complete range, 3 -44, 3 -45
 reverse external torque limit, 3 -17
 reverse rotation mode, 3 -7
 rotation direction selection, 3 -7
 speed loop gain, 3 -116
 speed loop integration time constant, 3 -116
 stopping motor at servo OFF, 3 -28, 3 -111
 stopping the motor at overtravel, 3 -27
 time delay from brake signal output to servo OFF, 3 -113
 torque command filter selection, 3 -117
 torque command filter time constant, 3 -116

peripheral devices
 selection, 6 -150
 flowchart, 6 -151
 specifications, 6 -190
 wiring, 2 -13

personal computer, 2 -15

positioning time, minimizing, 3 -118

power amplifiers, 1 -9

precautions, 2 -2

proportional/integral control, 1 -9

pulse dividing ratio, 3 -105

R

radial load, 2 -8

ratings
 100-VAC SGM Servomotors, 6 -27, 6 -31, 6 -33
 200-VAC SGM Servomotors, 6 -19, 6 -23

regenerative resistor unit, 2 -15
 dimensional drawings, 6 -246
 specifications, 6 -246

regenerative unit
 connection, 3 -133
 models, 3 -133

residual voltage, precautions, 2 -2

reverse rotation mode, 3 -7
 parameter, 3 -7

rotation, 3 -27
 forward, prohibiting, 3 -27
 reverse, prohibiting, 3 -27

running output signal, 3 -43

S

servo amplifiers, 1 -8
 meaning, 1 -5

servo drive, meaning, 1 -4

servo mechanisms
 illustration, 1 -5
 meaning, 1 -2

servo OFF, 3 -28

servo ON input signal, 3 -21

Servomotors, 7 -2
 100-VAC SGM ratings, 6 -27, 6 -31, 6 -33
 100-VAC SGM specifications, 6 -27, 6 -31, 6 -33
 200-VAC SGM ratings, 6 -19, 6 -23
 200-VAC SGM specifications, 6 -19, 6 -23
 200-VAC SGM torque-motor speed characteristics, 6
 -22, 6 -26, 6 -30, 6 -33, 6 -36

AC, 1 -7
 induction, 1 -7
 synchronous, 1 -7

components, 1 -7

DC, 1 -7

dimensional drawings, 6 -55

inspection, 7 -2

installation, 2 -7

maintenance, 7 -2

meaning, 1 -4, 1 -5

overhanging load, 6 -54

selection, 6 -3
 flowchart, 6 -5, 6 -9
 machine data table, 6 -11

setting the model, 3 -5

test run, 2 -24

SERVOPACKs, 7 -3
 AC, gain adjustment, A -2
 dimensional drawings, 6 -138
 high-voltage lines, 3 -140
 inspection, 7 -3
 installation, 2 -10
 instrument connection examples, 7 -36
 internal connection diagram, 7 -36
 maintenance, 7 -3
 meaning, 1 -4
 overload characteristics, 6 -52
 position control
 auto-tuning, A -4
 manual adjustment, A -5
 selection, 6 -15
 according to the motor, 6 -16

servos
 alarm reset, 5 -4
 control systems, meaning, 1 -4
 gain adjustment, 3 -115

meaning, 1 -4

shaft opening, 2 -8

specifications
 100-VAC SGM Servomotors, 6 -27, 6 -31, 6 -33
 200-VAC SGM Servomotors, 6 -19, 6 -23
 brake power supply, 6 -216
 cables, 6 -190
 encoders, 6 -218
 connector kits, 6 -195
 magnetic contactor, 6 -243
 peripheral devices, 6 -190
 regenerative resistor unit, 6 -246
 SERVOPACK/Servomotor combination, 6 -45

speed bias, 3 -119

starting time, 6 -53

stopping time, 6 -53

T

terminals
 standard motor with brake, 3 -151, 3 -153
 standard motor without brake, 3 -150, 3 -152

test run, 2 -23
 motor alone, 2 -24
 motor connected to the machine, 2 -28
 servomotor with brake, 2 -29

thrust load, 2 -8

torque command filter time constant, 3 -116

torque restriction function, torque limit value, 3 -17

troubleshooting
 alarm display, 7 -5
 without alarm display, 7 -34

V

vibration class, 6 -44

vibration resistance, 6 -43

voltage resistance test, 2 -3

W

wiring, 2 -13, 3 -125
 grounding, 3 -127
 more than one servo drive, 3 -131
 noise control, 3 -126
 peripheral devices, 2 -13
 precautions, 2 -2, 3 -125

Revision History

The revision dates and numbers of the revised manuals are given on the bottom of the back cover.

MANUAL NO. SIE-S800-16.3B

© Printed in Japan September 1999 99-09 ①
Date of printing Date of original publication Revision number

Date of Printing	Rev. No.	Section	Revised Content
September 1999	–	–	First edition
March 2003	①	Back cover	Revision: Address
February 2005	②	All chapters	Completely revised
July 2005	③	Back cover	Revision: Address

Σ Series SGM□/SGDB-□□AM USER'S MANUAL

IRUMA BUSINESS CENTER (SOLUTION CENTER)

480, Kamifujisawa, Iruma, Saitama 358-8555, Japan
Phone 81-4-2962-5696 Fax 81-4-2962-6138

YASKAWA ELECTRIC AMERICA, INC.

2121 Norman Drive South, Waukegan, IL 60085, U.S.A.
Phone 1-847-887-7000 Fax 1-847-887-7370

YASKAWA ELÉTRICO DO BRASIL COMÉRCIO LTD.A.

Avenida Fagundes Filho, 620 Bairro Saude-Sao Paulo-SP, Brazil CEP: 04304-000
Phone 55-11-5071-2552 Fax 55-11-5581-8795

YASKAWA ELECTRIC EUROPE GmbH

Am Kronberger Hang 2, 65824 Schwalbach, Germany
Phone 49-6196-569-300 Fax 49-6196-569-312

YASKAWA ELECTRIC UK LTD.

1 Hunt Hill Orchardton Woods Cumbernauld, G68 9LF, United Kingdom
Phone 44-1236-735000 Fax 44-1236-458182

YASKAWA ELECTRIC KOREA CORPORATION

7F, Doore Bldg. 24, Yeoido-dong, Youngdungpo-Ku, Seoul 150-877, Korea
Phone 82-2-784-7844 Fax 82-2-784-8495

YASKAWA ELECTRIC (SINGAPORE) PTE. LTD.

151 Lorong Chuan, #04-01, New Tech Park 556741, Singapore
Phone 65-6282-3003 Fax 65-6289-3003

YASKAWA ELECTRIC (SHANGHAI) CO., LTD.

No.18 Xizang Zhong Road, Room 1702-1707, Harbour Ring Plaza Shanghai 200001, China
Phone 86-21-5385-2200 Fax 86-21-5385-3299

YASKAWA ELECTRIC (SHANGHAI) CO., LTD. BEIJING OFFICE

Room 1011A, Tower W3 Oriental Plaza, No.1 East Chang An Ave.,
Dong Cheng District, Beijing 100738, China
Phone 86-10-8518-4086 Fax 86-10-8518-4082

YASKAWA ELECTRIC TAIWAN CORPORATION

9F, 16, Nanking E. Rd., Sec. 3, Taipei, Taiwan
Phone 886-2-2502-5003 Fax 886-2-2505-1280



YASKAWA ELECTRIC CORPORATION

YASKAWA

In the event that the end user of this product is to be the military and said product is to be employed in any weapons systems or the manufacture thereof, the export will fall under the relevant regulations as stipulated in the Foreign Exchange and Foreign Trade Regulations. Therefore, be sure to follow all procedures and submit all relevant documentation according to any and all rules, regulations and laws that may apply.

Specifications are subject to change without notice for ongoing product modifications and improvements.

© 1999-2005 YASKAWA ELECTRIC CORPORATION. All rights reserved.

MANUAL NO. SIE-S800-16.3B

Printed in Japan July 2005 99-9

05-7 97-23059