

AC Servo Drives
 Σ -V Series
 Λ Σ -V Series for
Large-Capacity Models
 Λ Σ -7 Series
USER'S MANUAL
Safety Module

Model: SGDV-OSA01A

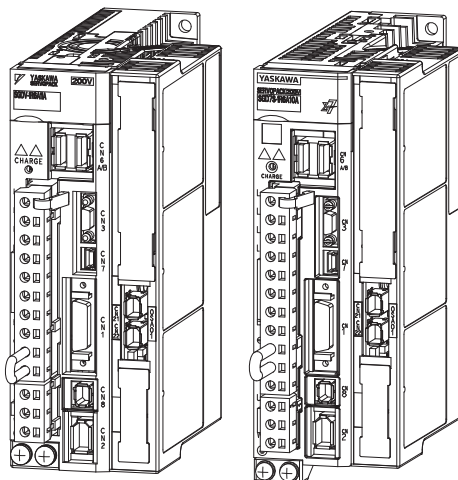

Checking Products	1
Specifications	2
SERVOPACK Installation	3
Wiring and Connection	4
Precautions and Basic Settings Required before Starting Operation	5
Safety Functions	6
Setting Parameters	7
Utility Functions	8
Monitor Mode	9
Active Mode Function	10
Troubleshooting	11
Appendix	12

Copyright © 2010 YASKAWA ELECTRIC CORPORATION

All rights reserved. No part of this publication may be reproduced, stored in a retrieval system, or transmitted, in any form, or by any means, mechanical, electronic, photocopying, recording, or otherwise, without the prior written permission of Yaskawa. No patent liability is assumed with respect to the use of the information contained herein. Moreover, because Yaskawa is constantly striving to improve its high-quality products, the information contained in this manual is subject to change without notice. Every precaution has been taken in the preparation of this manual. Nevertheless, Yaskawa assumes no responsibility for errors or omissions. Neither is any liability assumed for damages resulting from the use of the information contained in this publication.

About this Manual

This manual provides information required for designing and maintaining the Safety Module for Σ -V Series, Large-Capacity Σ -V Series, and Σ -7 Series SERVOPACKs.

Be sure to refer to this manual and perform design and maintenance to select devices correctly.

Keep this manual in a location where it can be accessed for reference whenever required.

■ IMPORTANT Explanations

The following icon is displayed for explanations requiring special attention.



IMPORTANT

- Indicates important information that should be memorized, as well as precautions, such as alarm displays, that do not involve potential damage to equipment.

■ Notation Used in this Manual

• Reverse Symbol Notation

In this manual, the names of reverse signals (ones that are valid when low) are written with a forward slash (/) before the signal name, as shown in the following example:

Example

The notation for $\overline{\text{BK}}$ is /BK.

• Parameter Notation

The following two types of notations are used for parameter digit places and settings.

Example

Notation Example for Pn000

$Pn000 = n . 0 0 0 0$

Digit Notation		Set Value Notation	
Notation Method	Meaning	Notation Method	Meaning
Digit 1 Pn000.0	Indicates digit 1 of the parameter (Pn000).	Pn000.0 = x or n.□□□x	Indicates that digit 1 of the parameter (Pn000) is x.
Digit 2 Pn000.1	Indicates digit 2 of the parameter (Pn000).	Pn000.1 = x or n.□□x□	Indicates that digit 2 of the parameter (Pn000) is x.
Digit 3 Pn000.2	Indicates digit 3 of the parameter (Pn000).	Pn000.2 = x or n.□x□□	Indicates that digit 3 of the parameter (Pn000) is x.
Digit 4 Pn000.3	Indicates digit 4 of the parameter (Pn000).	Pn000.3 = x or n.x□□□	Indicates that digit 4 of the parameter (Pn000) is x.

Related Manuals

■ Manuals Related to the Σ -V Series

Refer to the following manuals as required.

Name	Selecting Models and Peripheral Devices	Ratings and Specifications	System Design	Panels and Wiring	Trial Operation	Trial Operation and Servo Adjustment	Maintenance and Inspection
Σ -V Series Product Catalog (KAEP S800000 42)	✓	✓	✓				
Σ -V Series User's Manual Setup Rotational Motor (SIEP S800000 43)				✓	✓		
Σ -V Series User's Manual Setup Linear Motor (SIEP S800000 44)				✓	✓		
Σ -V Series User's Manual Design and Maintenance Rotational Motor Analog Voltage and Pulse Train Reference (SIEP S800000 45)		✓	✓		✓	✓	✓
Σ -V Series User's Manual Design and Maintenance Linear Motor Analog Voltage and Pulse Train Reference (SIEP S800000 47)		✓	✓		✓	✓	✓
Σ -V Series User's Manual Design and Maintenance Rotational Motor MECHATROLINK-II Communications Reference (SIEP S800000 46)		✓	✓		✓	✓	✓
Σ -V Series User's Manual Design and Maintenance Linear Motor MECHATROLINK-II Communications Reference (SIEP S800000 48)		✓	✓		✓	✓	✓
Σ -V Series/DC Power Input Σ -V Series/ Σ -V Series for Large-Capacity Models User's Manual MECHATROLINK-II Command (SIEP S800000 54)			✓		✓	✓	
Σ -V Series User's Manual Design and Maintenance Rotational Motor MECHATROLINK-III Communications Reference (SIEP S800000 64)		✓	✓		✓	✓	✓

(cont'd)

Name	Selecting Models and Peripheral Devices	Ratings and Specifications	System Design	Panels and Wiring	Trial Operation	Trial Operation and Servo Adjustment	Maintenance and Inspection
Σ -V Series User's Manual Design and Maintenance Linear Motor MECHATROLINK-III Communications Reference (SIEP S800000 65)		✓	✓		✓	✓	✓
Σ -V Series/DC Power Input Σ -V Series/ Σ -V Series for Large-Capacity Models User's Manual MECHATROLINK-III Standard Servo Profile Commands (SIEP S800000 63)			✓		✓	✓	
Σ -V Series User's Manual Design and Maintenance Rotational Motor Command Option Attachable Type (SIEP S800000 60)		✓	✓		✓	✓	✓
Σ -V Series User's Manual Design and Maintenance Linear Motor Command Option Attachable Type (SIEP S800000 66)		✓	✓		✓	✓	✓
Σ -V Series User's Manual Operation of Digital Operator (SIEP S800000 55)					✓	✓	
SigmaWin+ Online Manual Σ -V Component (SIEP S800000 73)					✓	✓	✓
Σ -V Series/ Σ -V Series for Large-Capacity Models/ Σ -7 Series Installation Guide Safety Module (TOBP C720829 06)				✓			
Σ -V Series AC SERVOPACK SGDV Safety Precautions (TOMP C710800 10)	✓			✓			✓
Σ -V Series/ Σ -V Series for Large-Capacity Models/ Σ -7 Series Option Module Safety Precautions (TOBP C720829 00)				✓			
Σ Series Digital Operator Safety Precautions (TOBP C730800 00)							✓
AC Servomotor Safety Precautions (TOBP C230200 00)				✓			✓

■ Manuals Related to the Large-Capacity Σ -V Series

Name	Selecting Models and Peripheral Devices	Ratings and Specifications	System Design	Panels and Wiring	Trial Operation	Trial Operation and Servo Adjustment	Maintenance and Inspection
Large-Capacity Σ -V Series (KAEPS 800000 86)	✓	✓	✓				
Σ -V Series User's Manual For Use with Large-Capacity Models Setup Rotational Motor (SIEP S800000 89)				✓	✓		
Σ -V Series User's Manual For Use with Large-Capacity Models Design and Maintenance Rotational Motor Analog Voltage and Pulse Train Reference (SIEP S800000 88)		✓	✓		✓	✓	✓
Σ -V Series User's Manual For Use with Large-Capacity Models Design and Maintenance Rotational Motor MECHATROLINK-II Communications Reference (SIEP S800000 90)		✓	✓		✓	✓	✓
Σ -V Series User's Manual For Use with Large-Capacity Models Design and Maintenance Rotational Motor MECHATROLINK-III Communications Reference (SIEP S800000 93)		✓	✓		✓	✓	✓
Σ -V Series User's Manual For Use with Large-Capacity Models Design and Maintenance Rotational Motor Command Option Attachable Type (SIEP S800000 98)		✓	✓		✓	✓	✓
Σ -V Series/DC Power Input Σ -V Series/ Σ -V Series for Large-Capacity Models User's Manual MECHATROLINK-II Command (SIEP S800000 54)			✓		✓	✓	
Σ -V Series/DC Power Input Σ -V Series/ Σ -V Series for Large-Capacity Models User's Manual MECHATROLINK-III Standard Servo Profile Commands (SIEP S800000 63)			✓		✓	✓	

(cont'd)

Name	Selecting Models and Peripheral Devices	Ratings and Specifications	System Design	Panels and Wiring	Trial Operation	Trial Operation and Servo Adjustment	Maintenance and Inspection
Σ -V Series User's Manual Operation of Digital Operator (SIEP S800000 55)					✓	✓	
SigmaWin+ Online Manual Σ -V Component (SIEP S800000 73)					✓	✓	✓
Σ -V Series/ Σ -V Series for Large-Capacity Models/ Σ -7 Series Installation Guide Safety Module (TOBP C720829 06)				✓			
AC SERVOPACK and Converter Σ -V Series Safety Precautions For Use with Large-Capacity Models (TOMP C710829 07)	✓			✓			✓
Σ -V Series/ Σ -V Series for Large-Capacity Models/ Σ -7 Series Option Module Safety Precautions (TOBP C720829 00)				✓			
Σ Series Digital Operator Safety Precautions (TOBP C730800 00)							✓
AC Servomotor Safety Precautions (TOBP C230200 00)				✓			✓

■ Manuals Related to the Σ -7 Series

Name	Selecting Models and Peripheral Devices	Ratings and Specifications	System Design	Panels and Wiring	Trial Operation	Trial Operation and Servo Adjustment	Maintenance and Inspection
Σ -7-Series AC Servo Drive Σ -7S SERVOPACK with Analog Voltage/ Pulse Train References Product Manual (SIEP S800001 26)	✓	✓	✓	✓	✓	✓	✓
Σ -7-Series AC Servo Drive Σ -7S SERVOPACK with MECHATROLINK-II Communications References Product Manual (SIEP S800001 27)	✓	✓	✓	✓	✓	✓	✓
Σ -7-Series AC Servo Drive Σ -7S SERVOPACK with MECHATROLINK-III Communications References Product Manual (SIEP S800001 28)	✓	✓	✓	✓	✓	✓	✓
Σ -7-Series AC Servo Drive Σ -7S SERVOPACK with MECHATROLINK-4 Communications References Product Manual (SIEP S800002 31)	✓	✓	✓	✓	✓	✓	✓
Σ -7-Series AC Servo Drive Rotary Servomotor Product Manual (SIEP S800001 36)	✓	✓	✓	✓			✓
Σ -7-Series AC Servo Drive Linear Servomotor Product Manual (SIEP S800001 37)	✓	✓	✓	✓			✓
Σ -7-Series AC Servo Drive Direct Drive Servomotor Product Manual (SIEP S800001 38)	✓	✓	✓	✓			✓
Σ -7-Series AC Servo Drive MECHATROLINK-II Communications Command Manual (SIEP S800001 30)			✓		✓	✓	

(cont'd)

Name	Selecting Models and Peripheral Devices	Ratings and Specifications	System Design	Panels and Wiring	Trial Operation	Trial Operation and Servo Adjustment	Maintenance and Inspection
Σ -7-Series AC Servo Drive MECHATROLINK-III Communications Standard Servo Profile Command Manual (SIEP S800001 31)			✓		✓	✓	
Σ -7-Series AC Servo Drive MECHATROLINK-4 Communications Standard Servo Profile Command Manual (SIEP S800002 32)			✓		✓	✓	
Σ -7-Series AC Servo Drive Peripheral Device Selection Manual (SIEP S800001 32)	✓	✓	✓	✓			
Σ -7-Series AC Servo Drive Digital Operator Operating Manual (SIEP S800001 33)					✓	✓	
Σ -7-Series AC Servo Drive Σ -7S and Σ -7W SERVOPACK Safety Precautions (TOMP C710828 00)	✓			✓			✓
Σ -V Series/ Σ -V Series for Large-Capacity Models/ Σ -7 Series Installation Guide Safety Module (TOBP C720829 06)				✓			
Σ -V Series/ Σ -V Series for Large-Capacity Models/ Σ -7 Series Option Module Safety Precautions (TOBP C720829 00)				✓			
Σ Series Digital Operator Safety Precautions (TOBP C730800 00)							✓
AC Servo Drives Rotary Servomotors Safety Precautions (TOBP C23026 00)				✓			✓

■ Safety Information

The following conventions are used to indicate precautions in this manual. Failure to heed precautions provided in this manual can result in serious or possibly even fatal injury or damage to the products or to related equipment and systems.



Indicates precautions that, if not heeded, could possibly result in loss of life or serious injury.



Indicates precautions that, if not heeded, could result in relatively serious or minor injury, damage to the product, or faulty operation. In some situations, the precautions indicated could have serious consequences if not heeded.



Indicates prohibited actions that must not be performed. For example, this symbol would be used to indicate that fire is prohibited as follows:



Indicates compulsory actions that must be performed. For example, this symbol would be used as follows to indicate that grounding is compulsory:



Safety Precautions

These safety precautions are very important. Read them before performing any procedures such as checking products on delivery, storage and transportation, installation, wiring, operation and inspection, or disposal. Be sure to always observe these precautions thoroughly.



WARNING

- Never touch any rotating motor parts while the motor is running.
Failure to observe this warning may result in injury.
- Before starting operation with a machine connected, make sure that an emergency stop can be applied at any time.
Failure to observe this warning may result in injury or damage to the product.
- Never touch the inside of the SERVOPACKs.
Failure to observe this warning may result in electric shock.
- Do not remove the cover of the power supply terminal block while the power is ON.
Failure to observe this warning may result in electric shock.
- After the power is turned OFF or after a voltage resistance test, do not touch terminals while the CHARGE lamp is ON.
Residual voltage may cause electric shock.
- Follow the procedures and instructions provided in this manual for trial operation.
Failure to do so may result not only in faulty operation and damage to equipment, but also in personal injury.
- The multi-turn serial data output range for the Σ -V Series, Large-Capacity Σ -V Series, and Σ -7 Series absolute position detecting system is different from that of earlier systems with 15-bit and 12-bit encoders. In particular, change the system to configure the Σ Series infinite-length positioning system with the Σ -V Series, Large-Capacity Σ -V Series, or Σ -7 Series.
- The multi-turn limit value need not be changed except for special applications.
Changing it inappropriately or unintentionally can be dangerous.
- If the Multi-turn Limit Disagreement alarm occurs, check the setting of parameter Pn205 in the SERVOPACK to be sure that it is correct.
If Fn013 is executed when an incorrect parameter value is set, an incorrect value will be set in the encoder. The alarm will disappear even if an incorrect value is set, but incorrect positions will be detected, resulting in a dangerous situation where the machine will move to unexpected positions.
- Do not remove the front cover, cables, connectors, or optional items from the upper front of the SERVOPACK while the power is ON.
Failure to observe this warning may result in electric shock.
- Do not damage, press, exert excessive force on, or place heavy objects on the cables.
Failure to observe this warning may result in electric shock, stopping operation of the product, or fire.
- Provide an appropriate stopping device on the machine side to ensure safety.
The holding brake on a servomotor with a brake is not a braking device for ensuring safety.
Failure to observe this warning may result in injury.
- Connect the ground terminal according to local electrical codes (100 Ω or less for a SERVOPACK with a 100 V, 200 V power supply, 10 Ω or less for a SERVOPACK with a 400 V power supply).
Improper grounding may result in electric shock or fire.





WARNING



- Installation, disassembly, or repair must be performed only by authorized personnel.
Failure to observe this warning may result in electric shock or injury.
- Engineers designing a mechanical system using the safety functions of the Safety Module must have complete knowledge of the relative safety standards and a full understanding of the safety functions of the Safety Module.
Improper use may result in injury or damage to the product.
- When creating a safety design for a mechanical system using the safety functions of the Safety Module, always perform risk assessment of the system to identify residual risks.
Improper use may result in injury or damage to the product.
- The dynamic brake is not a safety-related part of a control system. Create the safety design of the mechanical system in such a way that any trouble in the dynamic brake function does not create a hazard when the safety functions of the Safety Module operate.
Improper use may result in injury or damage to the product.
- Connect device conforming to the relative safety standards to the connector for Safety Request Input Signals.
Improper use may result in injury or damage to the product.
- The safety functions of the Safety Module are not for emergency stopping. To use the safety functions for emergency stopping, separately shut OFF the power supply from the electromechanical section to the motor.
Improper use may result in injury or damage to the product.
- The safety functions of the Safety Module are not for shutting OFF the power supply to the SERVOPACK and do not provide electrical isolation. Be sure to separately shut OFF the power supply to the SERVOPACK when performing maintenance or inspection of the SERVOPACK.
Failure to observe this warning may result in electric shock.
- Be sure to check the safety-related parameters before using the safety functions of the Safety Module.
Improper use may result in injury or damage to the product.
- If the Safety Module or SERVOPACK is changed when starting the servo system or during maintenance or inspection, be sure to check the operation of the safety functions in the actual application after performing wiring.
Improper use may result in injury or damage to the product.
- Make sure that the safety function jumper connector is not connected to the connector (CN8) of the SERVOPACK.
If the safety jumper connector is connected, the safety functions may not operate properly, which may result in injury or damage to the product.

■ Storage and Transportation

CAUTION

- Do not store or install the product in the following locations.
Failure to observe this caution may result in fire, electric shock, or damage to the product.
 - Locations subject to direct sunlight
 - Locations subject to ambient operating temperatures outside the range specified in the storage/installation temperature conditions
 - Locations subject to humidity outside the range specified in the storage/installation humidity conditions
 - Locations subject to condensation as the result of extreme changes in temperature
 - Locations subject to corrosive or flammable gases
 - Locations subject to dust, salts, or iron dust
 - Locations subject to exposure to water, oil, or chemicals
 - Locations subject to shock or vibration
- Do not hold the product by the cables, motor shaft or detector while transporting it.
Failure to observe this caution may result in injury or malfunction.
- Do not place any load exceeding the limit specified on the packing box.
Failure to observe this caution may result in injury or malfunction.
- If disinfectants or insecticides must be used to treat packing materials such as wooden frames, pallets, or plywood, the packing materials must be treated before the product is packaged, and methods other than fumigation must be used.
Example: Heat treatment, where materials are kiln-dried to a core temperature of 56°C for 30 minutes or more.
If the electronic products, which include stand-alone products and products installed in machines, are packed with fumigated wooden materials, the electrical components may be greatly damaged by the gases or fumes resulting from the fumigation process. In particular, disinfectants containing halogen, which includes chlorine, fluorine, bromine, or iodine can contribute to the erosion of the capacitors.

■ Installation

CAUTION

- Never use the product in an environment subject to water, corrosive gases, inflammable gases, or combustibles.
Failure to observe this caution may result in electric shock or fire.
- Do not step on or place a heavy object on the product.
Failure to observe this caution may result in injury.
- Do not cover the inlet or outlet ports and prevent any foreign objects from entering the product.
Failure to observe this caution may cause internal elements to deteriorate resulting in malfunction or fire.
- Be sure to install the product in the correct direction.
Failure to observe this caution may result in malfunction.
- Provide the specified clearances between the SERVOPACK and the control panel or with other devices.
Failure to observe this caution may result in fire or malfunction.
- Do not apply any strong impact.
Failure to observe this caution may result in malfunction.

■ Wiring



CAUTION

- Be sure to wire correctly and securely.
Failure to observe this caution may result in motor overrun, injury, or malfunction.
- Do not connect a commercial power supply to the U, V, or W terminals for the servomotor connection.
Failure to observe this caution may result in injury or fire.
- Securely connect the main circuit power supply terminal screws, control power supply terminal screws, and servomotor connection terminal screws.
Failure to observe this caution may result in fire.
- Do not bundle or run the main circuit cables together with the input/output signal cables or the encoder cables in the same duct. Keep them separated by at least 30 cm.
Failure to observe this caution may result in malfunction.
- Use shielded twisted-pair wires or multi-core shielded twisted-pair wires for input/output signal cables and the encoder cables.
- I/O signal cables must be no longer than 3 m, encoder cables must be no longer than 50 m, and control power supply cables for the SERVOPACK with a 400 V power supply (+24 V, 0 V) must be no longer than 10 m.
- Do not touch the power terminals while the CHARGE lamp is ON after turning power OFF because high voltage may still remain in the SERVOPACK.
Make sure the CHARGE lamp is OFF first before starting an inspection.
- Observe the following precautions when wiring main circuit terminal blocks of the SERVOPACK.
 - Remove the detachable main circuit terminal blocks from the SERVOPACK prior to wiring.
 - Insert only one main power line per opening in the main circuit terminals.
 - Make sure that no part of the core wire comes into contact with (i.e., short-circuit) adjacent wires.
- Install a battery at either the host controller or the SERVOPACK, but not both.
It is dangerous to install batteries at both ends simultaneously, because that sets up a loop circuit between the batteries.
- Always use the specified power supply voltage.
An incorrect voltage may result in fire or malfunction.
- Take appropriate measures to ensure that the input power supply is supplied within the specified voltage fluctuation range. Be particularly careful in places where the power supply is unstable.
An incorrect power supply may result in damage to the product.
- Install external breakers or other safety devices against short-circuiting in external wiring.
Failure to observe this caution may result in fire.
- Take appropriate and sufficient countermeasures for each form of potential interference when installing systems in the following locations.
 - Locations subject to static electricity or other forms of noise
 - Locations subject to strong electromagnetic fields and magnetic fields
 - Locations subject to possible exposure to radioactivity
 - Locations close to power suppliesFailure to observe this caution may result in damage to the product.
- Do not reverse the polarity of the battery when connecting it.
Failure to observe this caution may damage the battery, the SERVOPACK, the servomotor, or cause an explosion.
Wiring or inspection must be performed by a technical expert.
- Use a 24-VDC power supply with double insulation or reinforced insulation.

■ Operation

CAUTION

- Always use the servomotor and SERVOPACK in one of the specified combinations.
Failure to observe this caution so may result in fire or malfunction.
- Conduct trial operation on the servomotor alone with the motor shaft disconnected from the machine to avoid accidents.
Failure to observe this caution may result in injury.
- During trial operation, confirm that the holding brake works correctly. Furthermore, secure system safety against problems such as signal line disconnection.
- Before starting operation with a machine connected, change the settings to match the parameters of the machine.
Starting operation without matching the proper settings may cause the machine to run out of control or malfunction.
- Do not frequently turn power ON and OFF.
Since the SERVOPACK has a capacitor in the power supply, a high charging current flows when power is turned ON. Frequently turning power ON and OFF causes main power devices like capacitors and fuses to deteriorate, resulting in unexpected problems.
- When using JOG operations (Fn002), search operations (Fn003), or EasyFFT operations (Fn206), the dynamic brake function does not work for reverse overtravel or forward overtravel. Take necessary precautions.
- When using the servomotor for a vertical axis, install safety devices to prevent workpieces from falling due to alarms or overtravels. Set the servomotor so that it will stop in the zero clamp state when overtravel occurs.
Failure to observe this caution may cause workpieces to fall due to overtravel.
- When not using turning-less function, set to the correct moment of inertia ratio (Pn103).
Setting to an incorrect moment of inertia ratio may cause machine vibration.
- Do not touch the SERVOPACK heatsinks, regenerative resistor, or servomotor while power is ON or soon after the power is turned OFF.
Failure to observe this caution may result in burns due to high temperatures.
- Do not make any extreme adjustments or setting changes of parameters.
Failure to observe this caution may result in injury or damage to the product due to unstable operation.
- When an alarm occurs, remove the cause, reset the alarm after confirming safety, and then resume operation.
Failure to observe this caution may result in damage to the product, fire, or injury.
- Do not use the brake of the servomotor for braking.
Failure to observe this caution may result in malfunction.
- An alarm or warning may be generated if communications are executed with the host controller during operation using the digital operator.
If an alarm or warning is generated, the process currently being executed may be aborted and the system may stop.

■ Maintenance and Inspection

CAUTION

- Do not disassemble the SERVOPACK.
Failure to observe this caution may result in electric shock or injury.
- Do not change wiring while the power is ON.
Failure to observe this caution may result in electric shock or injury.
- When replacing the SERVOPACK, resume operation only after copying the previous SERVOPACK parameters to the new SERVOPACK.
Failure to observe this caution may result in damage to the product.

■ Disposal Precautions

 CAUTION	
<ul style="list-style-type: none">• Correctly discard the product as stipulated by regional, local, and municipal laws and regulations. Be sure to include these contents in all labelling and warning notifications on the final product as necessary.	 

■ General Precautions

Observe the following general precautions to ensure safe application.
<ul style="list-style-type: none">• The products shown in illustrations in this manual are sometimes shown without covers or protective guards. Always replace the cover or protective guard as specified first, and then operate the products in accordance with the manual.• The drawings presented in this manual are typical examples and may not match the product you received.• If the manual must be ordered due to loss or damage, inform your nearest Yaskawa representative or one of the offices listed on the back of this manual.

Warranty

(1) Details of Warranty

■ Warranty Period

The warranty period for a product that was purchased (hereinafter called “delivered product”) is one year from the time of delivery to the location specified by the customer or 18 months from the time of shipment from the Yaskawa factory, whichever is sooner.

■ Warranty Scope

Yaskawa shall replace or repair a defective product free of charge if a defect attributable to Yaskawa occurs during the warranty period above. This warranty does not cover defects caused by the delivered product reaching the end of its service life and replacement of parts that require replacement or that have a limited service life.

This warranty does not cover failures that result from any of the following causes.

1. Improper handling, abuse, or use in unsuitable conditions or in environments not described in product catalogs or manuals, or in any separately agreed-upon specifications
2. Causes not attributable to the delivered product itself
3. Modifications or repairs not performed by Yaskawa
4. Abuse of the delivered product in a manner in which it was not originally intended
5. Causes that were not foreseeable with the scientific and technological understanding at the time of shipment from Yaskawa
6. Events for which Yaskawa is not responsible, such as natural or human-made disasters

(2) Limitations of Liability

1. Yaskawa shall in no event be responsible for any damage or loss of opportunity to the customer that arises due to failure of the delivered product.
2. Yaskawa shall not be responsible for any programs (including parameter settings) or the results of program execution of the programs provided by the user or by a third party for use with programmable Yaskawa products.
3. The information described in product catalogs or manuals is provided for the purpose of the customer purchasing the appropriate product for the intended application. The use thereof does not guarantee that there are no infringements of intellectual property rights or other proprietary rights of Yaskawa or third parties, nor does it construe a license.
4. Yaskawa shall not be responsible for any damage arising from infringements of intellectual property rights or other proprietary rights of third parties as a result of using the information described in catalogs or manuals.

(3) Suitability for Use

1. It is the customer's responsibility to confirm conformity with any standards, codes, or regulations that apply if the Yaskawa product is used in combination with any other products.
2. The customer must confirm that the Yaskawa product is suitable for the systems, machines, and equipment used by the customer.
3. Consult with Yaskawa to determine whether use in the following applications is acceptable. If use in the application is acceptable, use the product with extra allowance in ratings and specifications, and provide safety measures to minimize hazards in the event of failure.
 - Outdoor use, use involving potential chemical contamination or electrical interference, or use in conditions or environments not described in product catalogs or manuals
 - Nuclear energy control systems, combustion systems, railroad systems, aviation systems, vehicle systems, medical equipment, amusement machines, and installations subject to separate industry or government regulations
 - Systems, machines, and equipment that may present a risk to life or property
 - Systems that require a high degree of reliability, such as systems that supply gas, water, or electricity, or systems that operate continuously 24 hours a day
 - Other systems that require a similar high degree of safety
4. Never use the product for an application involving serious risk to life or property without first ensuring that the system is designed to secure the required level of safety with risk warnings and redundancy, and that the Yaskawa product is properly rated and installed.
5. The circuit examples and other application examples described in product catalogs and manuals are for reference. Check the functionality and safety of the actual devices and equipment to be used before using the product.
6. Read and understand all use prohibitions and precautions, and operate the Yaskawa product correctly to prevent accidental harm to third parties.

(4) Specifications Change

The names, specifications, appearance, and accessories of products in product catalogs and manuals may be changed at any time based on improvements and other reasons. The next editions of the revised catalogs or manuals will be published with updated code numbers. Consult with your Yaskawa representative to confirm the actual specifications before purchasing a product.

Compliance with UL Standards, EU Directives, UK Regulations, and Other Safety Standards

■ North American Safety Standards (UL)



Product	Model	North American Safety Standards (UL File No.)
SERVOPACK	SGDV	UL508C (E147823)
	SGD7S	UL 61800-5-1 (E147823), CSA C22.2 No.274

Note: Applicable when the Safety Module is attached to the SERVOPACKs for use with the analog voltage and pulse train reference, with the MECHATROLINK-II/-III/-4 communications reference, with the MECHATROLINK-III communications reference, and with the command option attachable type.

■ EU Directives



Product	Model	EU Directives	Harmonized Standards
SERVOPACK	SGDV	Machinery Directive 2006/42/EC	EN ISO 13849-1: 2015 EN IEC 62061 EN 61800-5-2
		EMC Directive 2014/30/EU	EN 55011 Group 1, Class A EN 61000-6-2 EN 61000-6-4 EN 61800-3 (Category C2, Second environment)
		Low Voltage Directive 2014/35/EU	EN 61800-5-1
		RoHS Directive 2011/65/EU (EU)2015/863	EN IEC 63000
	SGD7S	Machinery Directive 2006/42/EC	EN ISO 13849-1: 2015 EN 61800-5-2
		EMC Directive 2014/30/EU	EN 55011 Group 1, Class A EN 61000-6-2 EN 61000-6-4 EN 61800-3 (Category C2, Second environment)
		Low Voltage Directive 2014/35/EU	EN 61800-5-1
		RoHS Directive 2011/65/EU (EU)2015/863	EN IEC 63000

Note: Applicable when the Safety Module is attached to the SERVOPACKs for use with the analog voltage and pulse train reference, with the MECHATROLINK-II/-III/-4 communications reference, with the MECHATROLINK-III communications reference, and with the command option attachable type.

■ UK Conformity Assessed (UKCA)



Product	Model	UK Regulations	Designated Standards
SERVOPACK	SGDV	Supply of Machinery (Safety) Regulations S.I. 2008/1597	EN ISO 13849-1: 2015 EN IEC 62061 EN 61800-5-2
		Electromagnetic Compatibility Regulations S.I. 2016/1091	EN 55011 Group 1, Class A EN 61000-6-2 EN 61000-6-4 EN 61800-3 (Category C2, Second environment)
		Electrical Equipment (Safety) Regulations S.I. 2016/1101	EN 61800-5-1
		Restriction of the Use of Certain Hazardous Substances in Electrical and Electronic Equipment Regulations S.I. 2012/3032	EN IEC 63000
	SGD7S	Supply of Machinery (Safety) Regulations S.I. 2008/1597	EN ISO 13849-1: 2015 EN 61800-5-2
		Electromagnetic Compatibility Regulations S.I. 2016/1091	EN 55011 Group 1, Class A EN 61000-6-2 EN 61000-6-4 EN 61800-3 (Category C2, Second environment)
		Electrical Equipment (Safety) Regulations S.I. 2016/1101	EN 61800-5-1
		Restriction of the Use of Certain Hazardous Substances in Electrical and Electronic Equipment Regulations S.I. 2012/3032	EN IEC 63000

Note: We declared the UKCA marking based on the designated standards in the above table.

■ Safety Standards

Product	Model	Safety Standards	Standards
SERVOPACK	SGDV	Safety of Machinery	EN ISO 13849-1: 2015 EN 60204-1
		Functional Safety	EN 61508 series EN IEC 62061 EN 61800-5-2
		Functional Safety EMC	EN 61326-3-1 EN 61000-6-7
	SGD7S	Safety of Machinery	EN ISO 13849-1: 2015 EN 60204-1
		Functional Safety	EN 61508 series EN 61800-5-2
		Functional Safety EMC	EN 61326-3-1 EN 61000-6-7

Note: Applicable when the Safety Module is attached to the SERVOPACKs for use with the analog voltage and pulse train reference, with the MECHATROLINK-II/-III/-4 communications reference, with the MECHATROLINK-III communications reference, and with the command option attachable type.

• Safe Performance

Items	Standards	Performance Level
Safety Integrity Level	EN 61508	SIL2
Probability of Dangerous Failure per Hour	EN 61508	$PFH \leq 3.3 \times 10^{-8}$ [1/h] (3.3% of SIL2)
Performance Level	EN ISO 13849-1	PL d (Category 2)
Mean Time to Dangerous Failure of Each Channel	EN ISO 13849-1	MTTFd: High
Average Diagnostic Coverage	EN ISO 13849-1	DCavg: Medium
Stop Category	EN 60204-1	Stop category 0/1/2
Safety Function	EN 61800-5-2	STO/SS1/SS2/SLS
Mission Time	EN 61508	20 years*
Hardware Fault Tolerance	EN 61508	HFT = 1
Subsystem	EN 61508	B

* Mission time 10 years and 20 years are valid and can be used for calculations.

Description of Technical Terms

The following table shows the meanings of terms used in this manual.

Term	Meaning
Servomotor	Σ -V Series/ Σ -7 Series: SGMJV, SGMAV, SGMPS, SGMGV, SGMSV, SGMCV (Direct Drive) or SGMCS (Direct Drive) servomotor Σ -V Series for Large-Capacity Models: SGMVV servomotor Σ -7 Series: SGM7J, SGM7A, SGM7P, SGM7G, SGM7D (Direct Drive), SGM7E (Direct Drive), or SGM7F (Direct Drive) servomotor Linear Σ Series: SGLGW, SGLFW, SGLFW2, SGLTW, or SGLC servomotor
SERVOPACK	Σ -V Series SGD _V SERVOPACK, Large-Capacity Σ -V Series SGD _V SERVOPACK, or Σ -7 Series SGD _{7S} SERVOPACK
Servo Drive	A set including a servomotor and SERVOPACK (i.e., a servo amplifier)
Servo System	A servo control system that includes the combination of a servo drive with a host controller and peripheral devices
Analog voltage and pulse train reference model	SGD _V or SGD _{7S} SERVOPACK with analog voltage and pulse train interface
M-II communications reference model	SGD _V or SGD _{7S} SERVOPACK with a MECHATROLINK-II communications reference interface
M-III communications reference model	SGD _V or SGD _{7S} SERVOPACK with a MECHATROLINK-III communications reference interface
M-4 communications reference model	SGD _{7S} SERVOPACK with a MECHATROLINK-4 communications reference interface
Command option attachable type	SERVOPACK on which a Command Option Module can be installed
Safety Option Module	Generic term for an Option Module that provides safety functions and is mounted on an SGD _V or SGD _{7S} SERVOPACK
Safety Module	The option module that provides safety functions specified in this manual.
Panel Operator	The operator with a panel display that is mounted on analog voltage and pulse-train reference SERVOPACKs.
Digital Operator	Handy type operator connected to SERVOPACKs
Servo ON	Power to motor ON
Servo OFF	Power to motor OFF
BaseBlock (BB)	Power supply to motor is turned OFF by shutting OFF the base current to the power transistor that supplies power to the motor.
Hardwire BaseBlock Function (HWBB)	Safety function in the SERVOPACK This is the safety function that is equivalent to the Safe Torque Off function defined in IEC 61800-5-2.
Safe Torque Off (STO)	This is one of safety functions defined in IEC 61800-5-2. This is the safety function that shuts OFF power supply to the motor.
Safe Stop 1 (SS1)	This is one of safety functions defined in IEC 61800-5-2. This is the safety function that starts deceleration of the motor and executes the STO function after a specified time has passed.
Safe Stop 2 (SS2)	This is one of safety functions defined in IEC 61800-5-2. This is the safety function that starts deceleration of the motor and prevents the motor from stopping at a distance greater than the allowable deviation from the specified position after a specified time has passed.
Safely-Limited Speed (SLS)	This is one of safety functions defined in IEC 61800-5-2. This is the safety function that prevents the motor speed from exceeding the specified speed.
Safe BaseBlock Function (SBB function)	This is one of safety functions in the Safety Module. This is the safety function that is equivalent to the Safe Torque Off function defined in IEC 61800-5-2.

(cont'd)

Term	Meaning	
Safe BaseBlock with Delay Function (SBB-D function)	This is one of safety functions in the Safety Module. This is the safety function that is equivalent to the Safe Stop 1 function defined in IEC 61800-5-2.	
Safe Position Monitor with Delay Function (SPM-D function)	This is one of safety functions in the Safety Module. This is the safety function that is equivalent to the Safe Stop 2 function defined in IEC 61800-5-2.	
Safely Limited Speed with Delay Function (SLS-D function)	Stopping function in the Safety Module. This is the safety function that is equivalent to the Safely-Limited Speed function defined in IEC 61800-5-2.	
Safe (HWBB) state	The Safety Module is shutting OFF power supply to the motor by executing the HWBB function of SGDV SERVOPACK.	
Safe State	Safe state depends on safety functions used.	
	SBB function	Safe (HWBB) state
	SBB-D function	Safe (HWBB) state
	SPM-D function	When monitoring positions or in a safe (HWBB) state
	SLS-D function	When monitoring constant-speed operation or in a safe (HWBB) state
Deceleration Monitoring	The Safety Module is monitoring deceleration operation of the motor.	
Position Monitoring	The Safety Module is monitoring distance that the motor moved.	
Constant-speed Monitoring	The Safety Module is monitoring constant-speed operation of the motor.	
Safety-related Module Parameter	Parameter related to the safety functions of the Safety Module.	
Safety-related Servo Parameter	These parameters contain the information related to the safety functions of SERVO-PACKs and servomotors, and are managed by the Safety Module.	
System Reset	Reset the servo system by shutting OFF the power or executing software reset (Fn030).	
Parameter Recalculation	Recalculation of parameter by CONFIG command via MECHATROLINK-II or by the request from the Command Option Module.	
Proof Test	Scheduled tests defined in IEC 61508-4.	
	This is the test that is used to detect the failure of the safety-related system.	

CONTENTS

About this Manual	iii
Related Manuals	iv
Safety Precautions	xi
Warranty	xvii
Compliance with UL Standards, EU Directives, UK Regulations, and Other Safety Standards	xix
Description of Technical Terms	xxii
Chapter 1 Checking Products	1-1
1.1 Checking Products on Delivery	1-2
1.2 Nameplate (Ratings) and Model Designation	1-3
1.3 Nameplate Location	1-3
Chapter 2 Specifications	2-1
2.1 Overview	2-2
2.2 Specifications	2-3
2.3 Part Names	2-5
2.4 Internal Block Diagram	2-6
Chapter 3 SERVOPACK Installation	3-1
3.1 SERVOPACK Installation Environment and Harmonized Standards	3-2
3.1.1 Installation Environment	3-2
3.1.2 Installation Conditions for Harmonized Standards	3-2
3.2 SERVOPACK Installation	3-3
3.2.1 Orientation	3-3
3.2.2 Installation Standards	3-4
3.3 EMC Installation Conditions	3-6
3.3.1 Σ -V Series	3-7
3.3.2 Σ -V Series for Large-Capacity Models	3-38
3.3.3 Σ -7 Series	3-46
3.3.4 Other Precautions	3-50
Chapter 4 Wiring and Connection	4-1
4.1 System Configuration Diagram	4-2
4.1.1 Σ -V Series System Configuration Diagram	4-2
4.1.2 Σ -7 Series System Configuration Diagram	4-3
4.2 I/O Signal Connections	4-4
4.2.1 Terminal Layout	4-4
4.2.2 Electrical Specifications and Connections of Input Circuit	4-5
4.2.3 Electrical Specifications and Connections of Output Circuit	4-6

Chapter 5 Precautions and Basic Settings Required before Starting Operation . . .5-1

5.1 Safety Precautions for Using the Safety Module	5-2
5.2 Risk Assessment	5-3
5.3 Limitations	5-4
5.3.1 Limitations on Lower Limit of Encoder Output Pulses	5-4
5.3.2 Limitations on the Use of the Test without Motor Function.	5-7
5.3.3 Limitations on the Use of an External Encoder	5-7
5.3.4 Device Combination	5-7
5.4 Basic Settings Required before Starting Operation	5-8
5.5 Checking the Operation	5-9

Chapter 6 Safety Functions.6-1

6.1 Overview	6-2
6.2 Common Items.	6-3
6.2.1 Selecting a Safety Function	6-3
6.2.2 Safety Request Input Signals.	6-4
6.2.3 External Device Monitor Output Signals	6-7
6.2.4 Operations After Alarms and Resetting Systems, and While Recalculating Parameters	6-10
6.2.5 Validating Safety Functions	6-11
6.3 Safe BaseBlock Function (SBB Function)	6-12
6.3.1 Basic Operation	6-12
6.3.2 Settings	6-12
6.3.3 Returning Method.	6-12
6.3.4 Exceptional Operation	6-13
6.3.5 Related SERVOPACK Functions.	6-14
6.4 Safe BaseBlock with Delay Function (SBB-D Function)	6-18
6.4.1 Basic Operation	6-18
6.4.2 Settings	6-20
6.4.3 Returning Method.	6-20
6.4.4 Exceptional Operation	6-20
6.4.5 Related SERVOPACK Functions	6-21
6.5 Safe Position Monitor with Delay Function (SPM-D Function).	6-22
6.5.1 Basic Operation	6-22
6.5.2 Settings	6-24
6.5.3 Returning Method.	6-24
6.5.4 Exceptional Operation	6-24
6.5.5 Related SERVOPACK Functions	6-25
6.6 Safely Limited Speed with Delay Function (SLS-D Function)	6-26
6.6.1 Basic Operation	6-26
6.6.2 Settings	6-28
6.6.3 Returning Method.	6-28
6.6.4 Exceptional Operation	6-29
6.6.5 Related SERVOPACK Functions	6-29
6.7 Order of Priority of Safety Functions	6-30
6.8 Application Example of Safety Functions.	6-32

Chapter 7 Setting Parameters	7-1
7.1 Types of Parameters	7-2
7.2 Safety-related Module Parameters	7-3
7.2.1 Overview	7-3
7.2.2 Operation Procedures	7-4
7.3 Safety-related Servo Parameters	7-7
7.3.1 Overview	7-7
7.3.2 Operation Procedures	7-8
Chapter 8 Utility Functions	8-1
8.1 List of Utility Functions	8-2
8.2 Safety Option Module Access Mode Setting (Fn040)	8-3
8.2.1 Overview	8-3
8.2.2 Operation Procedures	8-3
8.3 Safety-related Module Parameter Setting (Fn041)	8-5
8.3.1 Overview	8-5
8.3.2 Operation Procedures	8-6
8.4 Safety-related Servo Parameter Updating (Fn042)	8-8
8.4.1 Overview	8-8
8.4.2 Operation Procedures	8-8
8.5 Safety Option Module Initializing Parameter Setting (Fn043)	8-12
8.5.1 Overview	8-12
8.5.2 Operation Procedures	8-12
8.6 Safety Option Module Setup Alarm Clear (Fn044)	8-14
8.6.1 Overview	8-14
8.6.2 Operation Procedures	8-15
8.7 Related Utility Functions	8-17
8.7.1 Software Version Display (Fn012)	8-17
8.7.2 Resetting Configuration Error in Option Modules (Fn014)	8-17
8.7.3 Display of SERVOPACK and Servomotor ID (Fn01E)	8-17
Chapter 9 Monitor Mode	9-1
9.1 Overview	9-2
9.1.1 List of Monitor Modes	9-2
9.1.2 Status Display	9-3
9.2 Monitoring from the Panel Operator and Digital Operator	9-5
9.2.1 Safety Module I/O Signal Monitor (Un016)	9-5
9.2.2 Safety Module Safety Function Status (Un017)	9-5
9.2.3 Safety Module System Status (Un018)	9-6
9.2.4 Time until Arrival at Safety Speed (Un019 and Un01A)	9-7
9.2.5 Active Mode Reference Speed (Un01B)	9-8
9.2.6 Safety Module Motor Speed (Un01C)	9-8
9.2.7 Safety Module Motor Position (Un01D)	9-8
9.2.8 Safety Module Monitoring Speed (Un01E, Un01F)	9-8
9.3 Monitoring Over the Network	9-9
9.3.1 SERVOPACK for Use with MECHATROLINK-II Communications Reference	9-9
9.3.2 SERVOPACK for Use with MECHATROLINK-III Communications Reference	9-10
9.3.3 SERVOPACK for Use with MECHATROLINK-4 Communications Reference	9-12
9.3.4 SERVOPACK for Use with Command Option Module	9-13

Chapter 10 Active Mode Function	10-1
10.1 Overview	10-2
10.2 Basic Functions	10-2
10.2.1 Internal Deceleration References	10-3
10.2.2 Active Mode Hold Time	10-3
10.2.3 Position Error Level for Releasing Active Mode	10-4
10.2.4 Speed Reference Level for Releasing Active Mode	10-5
10.2.5 Monitoring Active Mode Function	10-6
10.3 Settings	10-12
10.4 Returning Method	10-13
10.4.1 Returning Conditions	10-13
10.4.2 SERVOPACK for Use with Analog Voltage and Pulse Train Reference	10-13
10.4.3 SERVOPACK for Use with MECHATROLINK-II Communications Reference	10-15
10.4.4 SERVOPACK for Use with MECHATROLINK-III Communications Reference	10-17
10.4.5 SERVOPACK for Use with MECHATROLINK-4 Communications Reference	10-19
10.4.6 SERVOPACK for Use with Command Option Module	10-20
10.5 Exceptional Operation	10-21
10.6 Related SERVOPACK Functions	10-22
10.6.1 Utility Functions	10-22
10.6.2 Overtravel	10-23
10.6.3 Servo ON Command	10-23
10.6.4 Zero-clamp Function	10-23
10.6.5 Speed Feedforward Function	10-23
10.6.6 Torque Feedforward Function	10-23

Chapter 11 Troubleshooting	11-1
11.1 List of Alarms	11-2
11.2 Troubleshooting of Alarms	11-3

Chapter 12 Appendix	12-1
12.1 Safety-related Module Parameters	12-2
12.2 Safety-related Servo Parameters	12-4
12.3 Parameters Related Active Mode Function	12-6
12.4 Device Combinations	12-8
12.4.1 SERVOPACKs	12-8
12.4.2 Servomotors	12-8
12.4.3 Serial Converter Units	12-13

Index	Index-1
------------------------	----------------

Revision History



Checking Products

This chapter describes how to check products upon delivery.

1.1	Checking Products on Delivery	1-2
1.2	Nameplate (Ratings) and Model Designation	1-3
1.3	Nameplate Location	1-3

1.1 Checking Products on Delivery

■ When the Safety Module is Not Connected to the SERVOPACK

1. Check the nameplate (ratings) to confirm that the product is the one that was ordered. For the nameplate (ratings), refer to *1.2 Nameplate (Ratings) and Model Designation*.
2. Mount the Safety Module to the SERVOPACK as described in the enclosed *Σ-V Series/Σ-V Series for Large-Capacity Models/Σ-7 Series Safety Option Module Installation Guide*. For the location of the nameplate, refer to *1.3 Nameplate Location*.
3. Remove the safety function jumper connector from the connector (CN8) of the SERVOPACK.

■ When the Safety Module is Connected to the SERVOPACK

1. Check the nameplate (ratings) to confirm that the Module that is mounted is the Safety Module.
2. Check that the safety function jumper connector is not connected to the connector (CN8) of the SERVOPACK.

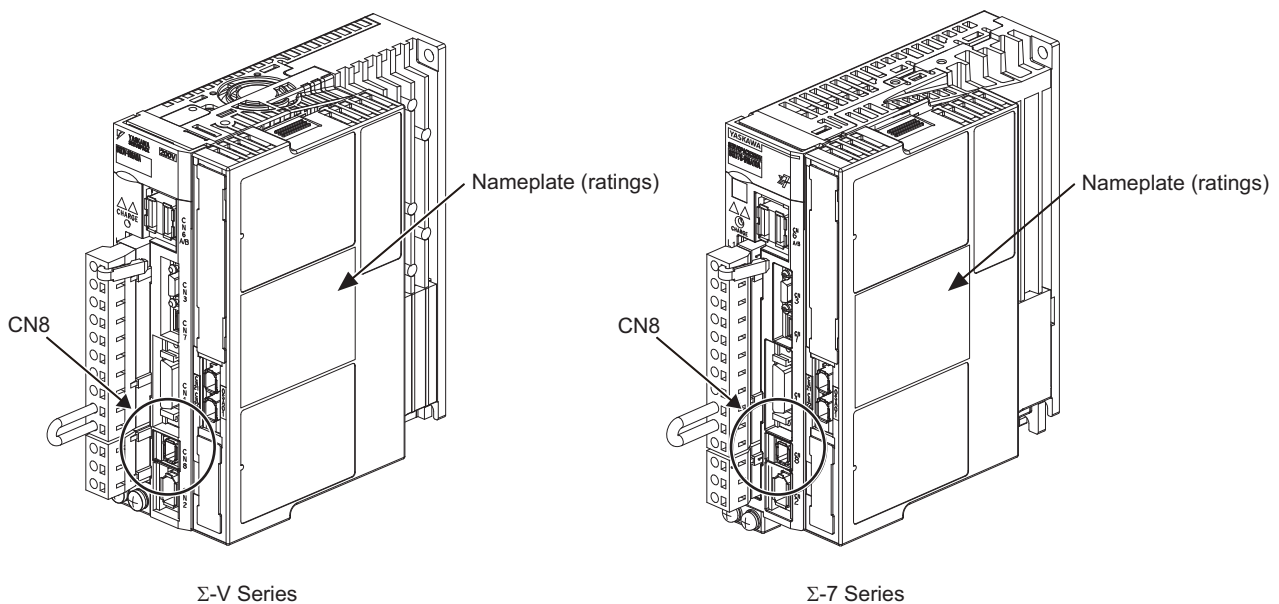

1.2 Nameplate (Ratings) and Model Designation

■ Nameplate (Ratings) Example

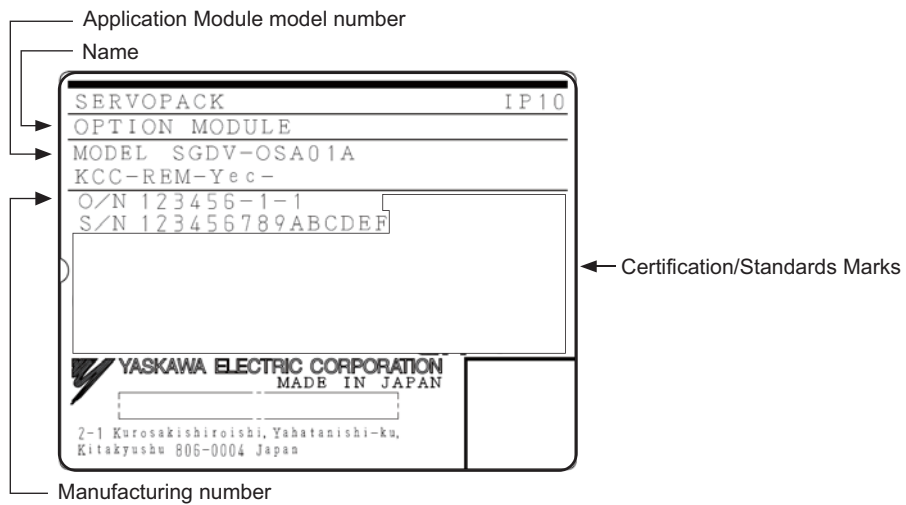

■ Model Designation

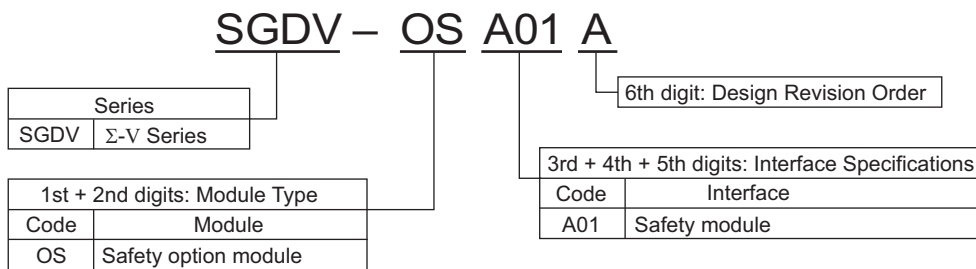

1.3 Nameplate Location

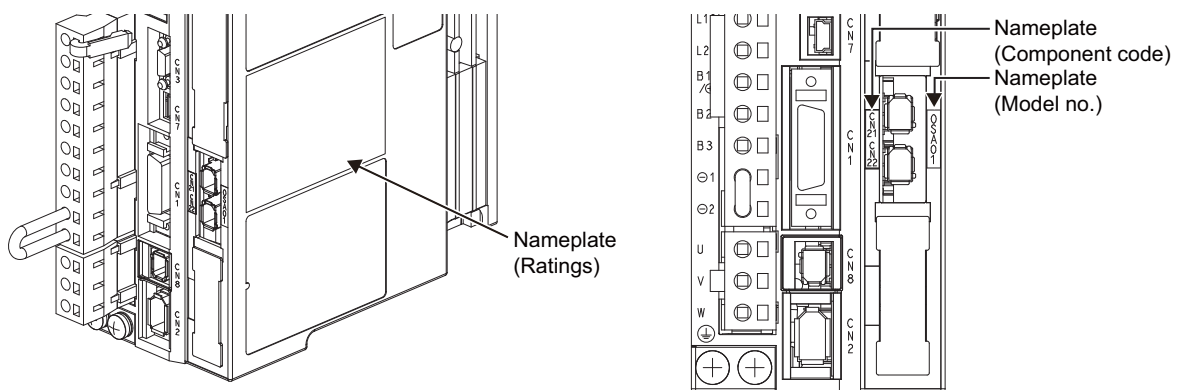

Specifications

This chapter gives an overview and describes the specifications of the Safety Module.

2.1 Overview	2-2
2.2 Specifications	2-3
2.3 Part Names	2-5
2.4 Internal Block Diagram	2-6

2.1 Overview

The Safety Module is an Option Module that is connected to a Σ -V Series, Large-Capacity Σ -V Series, or Σ -7 Series SERVOPACK. By using the Hard Wire BaseBlock function of the SERVOPACK, the following four safety functions, which are defined in functional safety standards, can be achieved.

Function	Remarks
Safe BaseBlock Function (SBB function)	This is a safety function that is equivalent to the Safe Torque Off function defined in IEC 61800-5-2.
Safe BaseBlock with Delay Function (SBB-D function)	This is a safety function that is equivalent to the Safe Stop 1 function defined in IEC 61800-5-2.
Safe Position Monitor with Delay Function (SPM-D function)	This is a safety function that is equivalent to the Safe Stop 2 function defined in IEC 61800-5-2.
Safely Limited Speed with Delay Function (SLS-D function)	This is a safety function that is equivalent to the Safely-Limited Speed function defined in IEC 61800-5-2.

2.2 Specifications

This table lists the general specifications of the Safety Module.

Applicable SERVOPACK		Σ-V Series /Σ-V Series for Large-Capacity Models	Rotational motor	SGDV-□□□□01 (analog voltage and pulse train reference models) SGDV-□□□□11 (M-II communications reference models) SGDV-□□□□E1 (command option attachable type) SGDV-□□□□21 (M-III communications reference models)
			Linear motor	SGDV-□□□□05 (analog voltage and pulse train reference models) SGDV-□□□□15 (M-II communications reference models) SGDV-□□□□E5 (command option attachable type) SGDV-□□□□25 (M-III communications reference models)
		Σ-7 Series Σ-7S	Rotational/ linear motor	SGD7S-□□□A00 (analog voltage and pulse train reference models) SGD7S-□□□A10 (M-II communications reference models) SGD7S-□□□A20 (M-III communications reference models) SGD7S-□□□A40 (M-4 communications reference models)
Placement		Attached to the SERVOPACK		
Power Specification	Power Supply Method	Supplied from the control power supply of the SERVOPACK.		
Operating Conditions	Surrounding Air/Storage Temperature	0°C to +55°C/ -20°C to +85°C		
	Ambient/Storage Humidity	90% RH or less (with no condensation)		
	Vibration/Shock Resistance	4.9 m/s ² / 19.6 m/s ²		
	Protection Class/ Pollution Degree	Protection class: IP10, Pollution degree: 2 An environment that satisfies the following conditions. <ul style="list-style-type: none"> • Free of corrosive or explosive gases • Free of exposure to water, oil or chemicals • Free of dust, salts or iron dust 		
	Altitude	1000 m or less		
	Others	Free of static electricity, strong electromagnetic fields, magnetic fields or exposure to radioactivity		
Safety Functions	Number of Functions: 2			
	Safety Function A	Inputs	Number of Channels	2
			Function	Safety Request Input Signal (SRI-A1, SRI-A2)
		Output	Number of Channels	1
			Function	External Device Monitor Output Signal (EDM-A)
	Safety Function B	Inputs	Number of Channels	2
			Function	Safety Request Input Signal (SRI-B1, SRI-B2)
		Output	Number of Channels	1
Function			External Device Monitor Output Signal (EDM-B)	

(cont'd)

	Safety Functions (IEC61800-5-2)	Function names of Safety Module
Stopping Methods	Safe Torque Off (STO)	Safe BaseBlock Function (SBB function)
	Safe Stop 1 (SS1)	Safe BaseBlock with Delay Function (SBB-D function)
	Safe Stop 2 (SS2)	Safe Position Monitor with Delay Function (SPM-D function)
	Safety-Limited Speed (SLS)	Safely Limited Speed with Delay Function (SLS-D function)
Others	Active Mode Function	
Response Time	Max. 200 ms	
Proof Test Interval	10 years	

2.3 Part Names

The following figure shows the part names of the Safety Module.

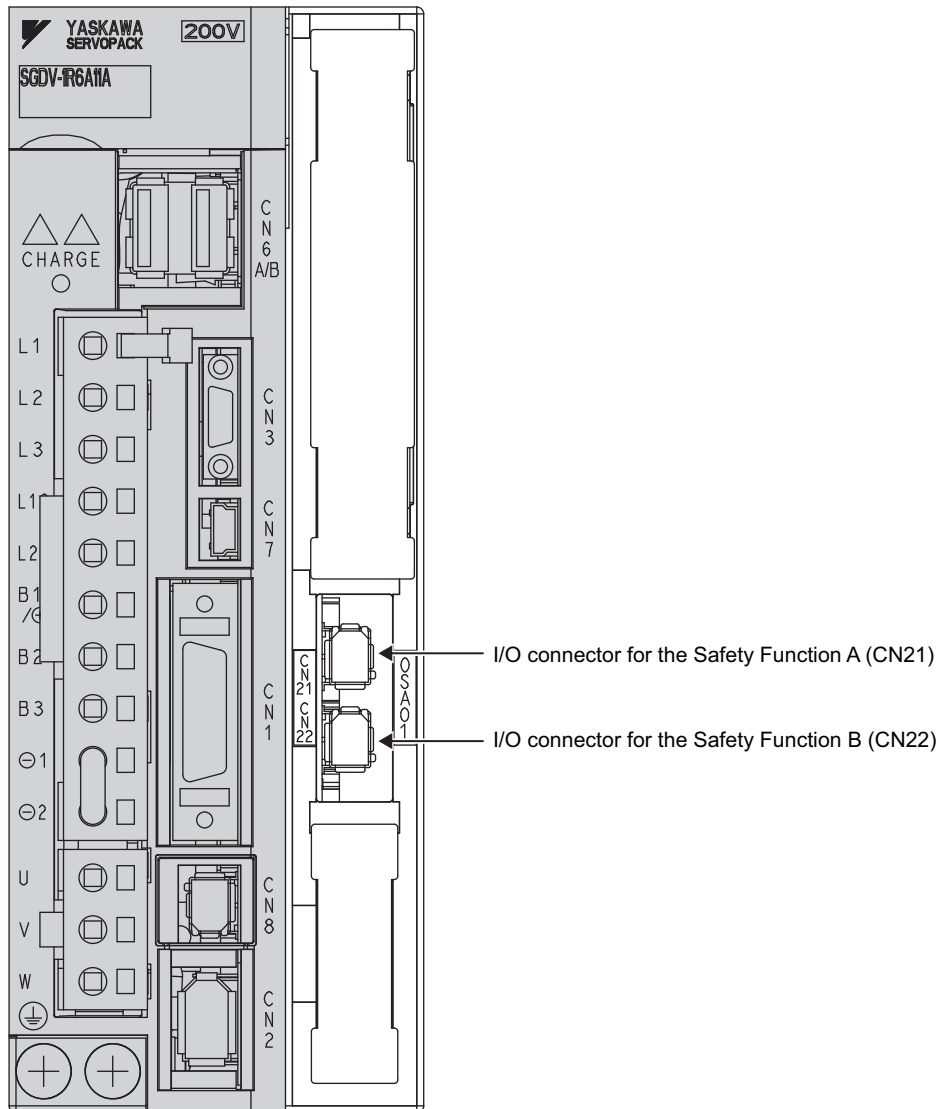

Note: For the names of the SERVOPACK parts, refer to the manual for your SERVOPACK.

2.4 Internal Block Diagram

This figure shows a typical internal block diagram.

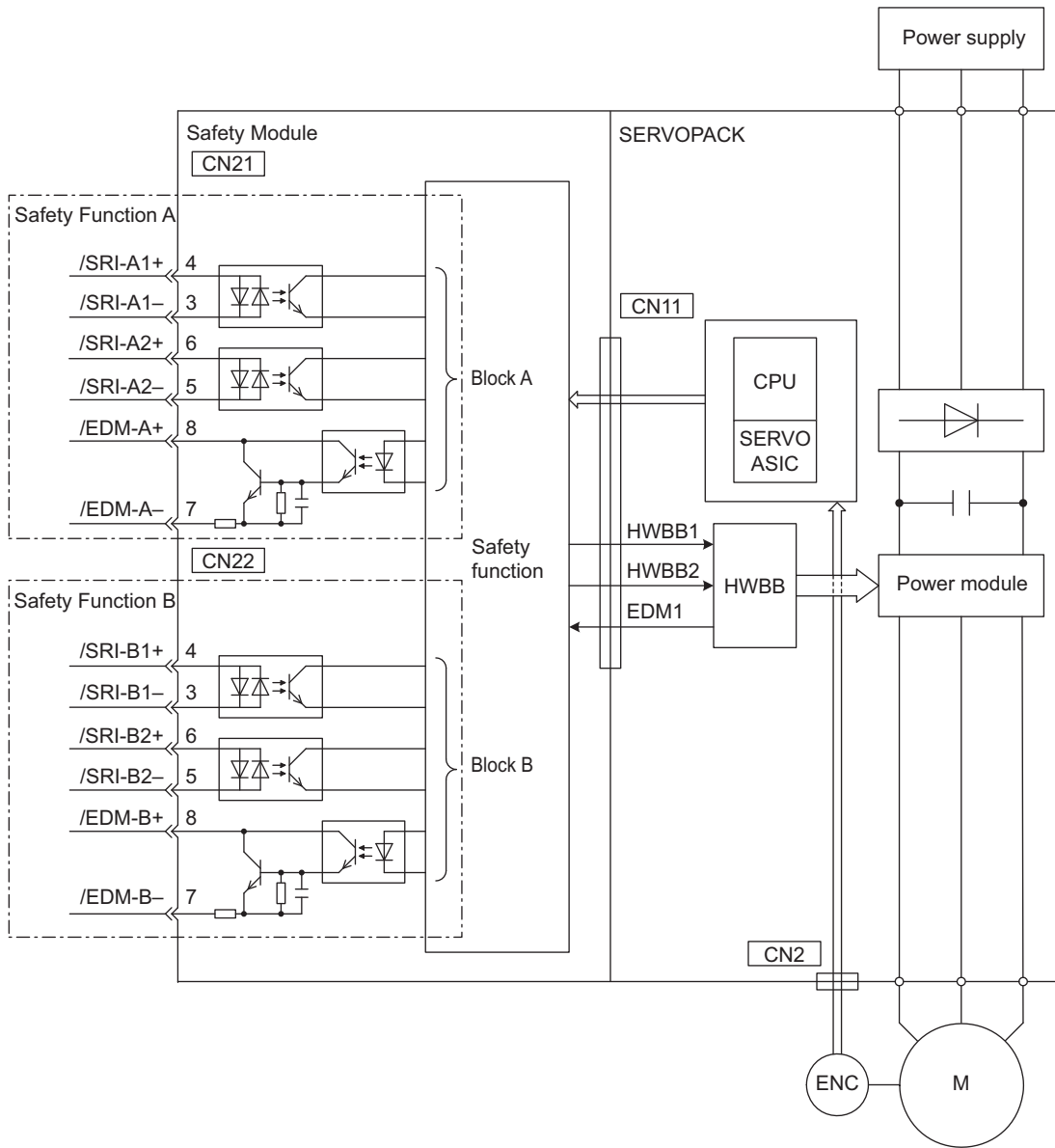

SERVOPACK Installation

This chapter describes how to install the SERVOPACK.

3.1	SERVOPACK Installation Environment and Harmonized Standards	3-2
3.1.1	Installation Environment	3-2
3.1.2	Installation Conditions for Harmonized Standards	3-2
3.2	SERVOPACK Installation	3-3
3.2.1	Orientation	3-3
3.2.2	Installation Standards	3-4
3.3	EMC Installation Conditions	3-6
3.3.1	Σ -V Series	3-7
3.3.2	Σ -V Series for Large-Capacity Models	3-38
3.3.3	Σ -7 Series	3-46
3.3.4	Other Precautions	3-50

3.1 SERVOPACK Installation Environment and Harmonized Standards

SERVOPACK installation environment and harmonized standards are as follows.

3.1.1 Installation Environment

- Surrounding air temperature: 0 to 55°C
- Ambient humidity: 90% RH or less (with no condensation)
- Altitude: 1,000 m or less
- Vibration resistance: 4.9 m/s²
- Shock resistance: 19.6 m/s²
- Installation Precautions

- Mounting in a Control Panel

To prevent the temperature around the SERVOPACK from exceeding 55°C, take into account the size of the control panel, the layout of the SERVOPACK, and the cooling method. For details, refer to 3.2 *SERVOPACK Installation*.

- Mounting Near a Heating Unit

To prevent the temperature around the SERVOPACK from exceeding 55°C, suppress radiant heat from the heating unit and temperature rise due to convection.

- Mounting Near a Vibration Source

To prevent vibration from being transmitted to the SERVOPACK, install a vibration isolator underneath the SERVOPACK.

- Mounting to a Location Exposed to Corrosive Gas

Take measures to prevent exposure to corrosive gas. Corrosive gases will not immediately affect the SERVOPACK, but will eventually cause electronic components and contactor-related devices to malfunction.

- Other Locations

Do not mount the SERVOPACK in locations subject to high temperatures, high humidity, dripping water, cutting oil, dust, iron filings, or radiation.

<Note>

When storing the SERVOPACK with the power OFF, store it in an environment with the following temperature and humidity:

- -20 to +85°C, 90% RH or less (with no condensation)

3.1.2 Installation Conditions for Harmonized Standards

Harmonized Standards	Refer to <i>Compliance with UL Standards, EU Directives, UK Regulations, and Other Safety Standards</i> in the preface for details.
Operating Conditions	Overvoltage category: III Pollution degree: 2 Protection class: IP10
Installation Conditions	UL Standards, Low Voltage Directive, and Electrical Equipment (Safety) Regulations: Satisfy the conditions outlined in <i>Σ-V Series or Large-Capacity Σ-V Series AC SERVOPACK Safety Precautions</i> or <i>Σ-7-Series AC Servo Drive Σ-7S/Σ-7W SERVOPACK Safety Precautions</i> . EMC Directive and Electromagnetic Compatibility Regulations: Certification is required after installation in the user's machine under the conditions outlined in 3.3 <i>EMC Installation Conditions</i> .

3.2 SERVOPACK Installation

3.2.1 Orientation

The SERVOPACK is available in models that are base-mounted, models that are rack-mounted, and models that are duct-ventilated. In any case, mount the SERVOPACK with a vertical orientation.

Firmly secure the SERVOPACK to the mounting surface, using either two or four mounting holes depending on the SERVOPACK capacity.

- Base-mounted

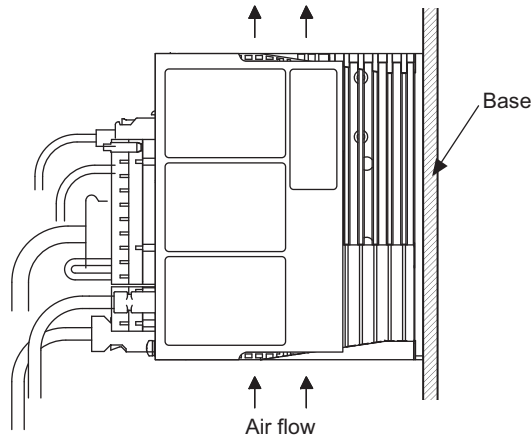

- Rack-mounted

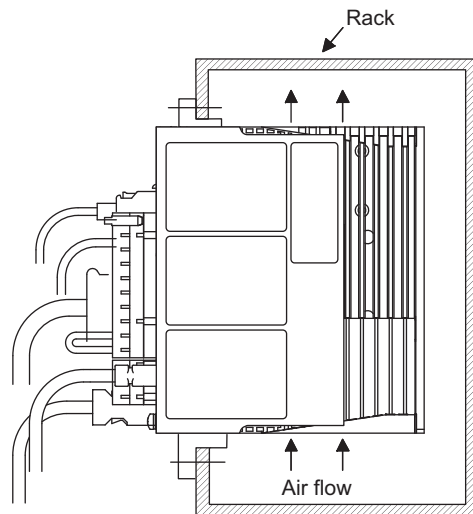

- Duct-ventilated

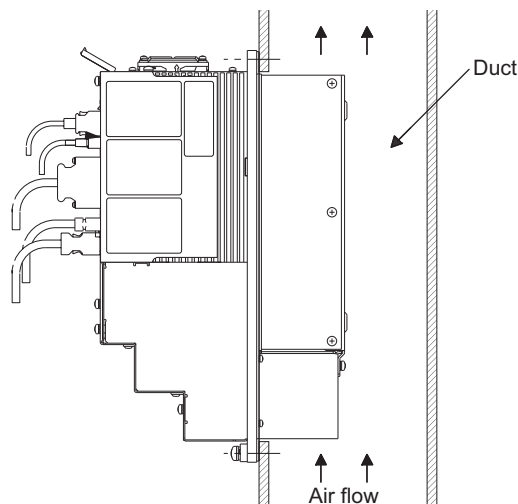

3.2.2 Installation Standards

Observe the standards for mounting SERVOPACKs in control panels, including those for the mounting SERVOPACKs side by side in one control panel as shown in the following illustration.

- **SERVOPACK Mounting Orientation**
Mount the SERVOPACK vertically to the wall, with the front panel (the side with the panel operator display) facing out.
- **Cooling**
Refer to the following diagram and leave sufficient space for cooling by fans and natural convection.
- **Mounting SERVOPACKs Side by Side in a Control Pane**
 - Σ -V Series

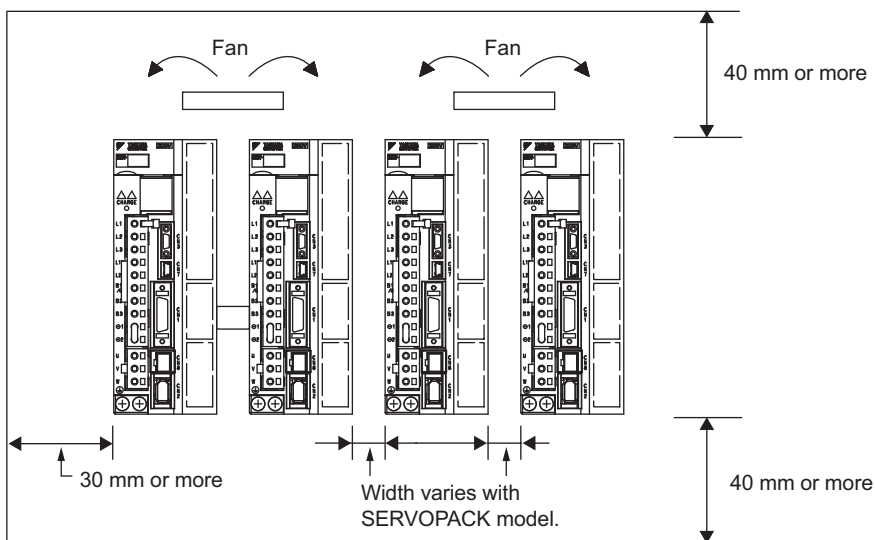

Leave sufficient space on each side and at the top and the bottom of each SERVOPACK. The width on each side varies in accordance with the models of the SERVOPACKs used.

SERVOPACK Model SGD V-	Side		Top and bottom
	Left	Right	
R70F, R90F, 2R1F, R70A, R90A, 1R6A, 2R8A	1 mm or more		40 mm or more
2R8F, 3R8A, 5R5A, 7R6A	1 mm or more	10 mm or more	
120A, 180A, 200A, 330A, 470A, 550A, 590A, 780A, 1R9D, 3R5D, 5R4D, 8R4D, 120D, 170D, 210D, 260D, 280D, 370D	10 mm or more		

Also install cooling fans above the SERVOPACKs to disperse local pockets of warmer air around the SERVOPACKs.

- **Large-Capacity Σ -V Series**

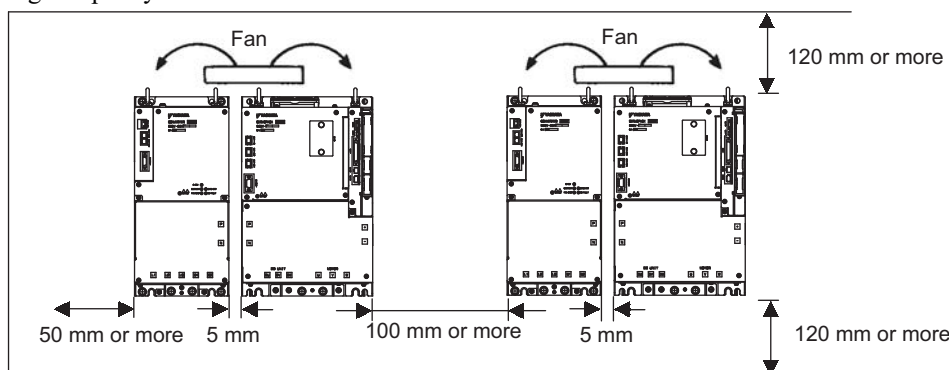

Also install cooling fans above the SERVOPACKs and converters to disperse local pockets of warmer air around them.

- Inside the Control Panel

The conditions inside the control panel should be the same as the environmental conditions of the SERVOPACK. Refer to 3.1.1 *Installation Environment*.

- Σ -7 Series

When multiple SERVOPACKs are installed close together in an enclosed space, natural convection may provide insufficient air circulation to distribute heat uniformly through the space, resulting in the air surrounding the SERVOPACKs to locally exceed the surrounding air temperature range. In this case, you must take measures to disperse the localized hot spots, such as by using fans. When using fans, install them as shown below.

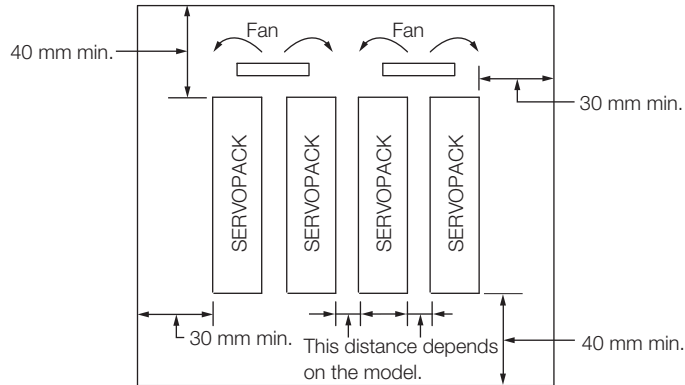

* For this dimension, ignore items protruding from the main body of the SERVOPACK.

The space required on the right side of a SERVOPACK (when looking at the SERVOPACK from the front) depends on the SERVOPACK models. Refer to the following table.

SERVOPACK Model		Space on Right Side	Cooling Fan Installation Conditions
			10 mm above SERVOPACK's Top Surface
SGD7S-	R70A, R90A, 1R6A, 2R8A, 3R8A, 5R5A, 7R6A	1 mm min.	Air speed: 0.5 m/s min.
	120A, 180A, 200A, 330A, 470A, 550A, 590A, 780A	10 mm min.	Air speed: 0.5 m/s min.

Note: When option modules are mounted on SERVOPACKs, the SERVOPACK installation conditions will depend on the option modules that are mounted. For details, refer to the manual for option module.

- Environmental Conditions inside the Control Panel

These conditions are the same as the environmental conditions of the SERVOPACK. Refer to 3.1.1 *Installation Environment*.

3.3 EMC Installation Conditions

This section gives the recommended installation conditions that were used for EMC certification testing for each model of the SGD V and SGD7S SERVOPACKs. The conditions required for the standard type (base-mounted) of the SERVOPACK are described. Refer to this section for other SERVOPACK models such as the rack-mounted types as well.

This section describes the EMC installation conditions satisfied in test conditions prepared by Yaskawa. The actual EMC level may differ depending on the actual system's configuration, wiring, and other conditions. However, because this product is built-in, check that the following conditions are still met after being installed in the user's product.

The harmonized standards are EN 55011 Group 1, Class A, EN 61000-6-2, EN 61000-6-4, and EN 61800-3 (Category C2, Second environment).



WARNING

- In a domestic environment, this product may cause radio interference in which case supplementary mitigation measures may be required.



CAUTION

- This equipment is not intended for use in residential environments and may not provide adequate protection to radio reception in such environments.

3.3.1 Σ-V Series

(1) SGD-V-□□□□0□□ (Analog Voltage and Pulse Train Reference Models)

■ Single-phase 100 V

- SGD-V-□□□F0□A (□□□ = R70, R90, 2R1, 2R8) + SGD-V-OSA01A

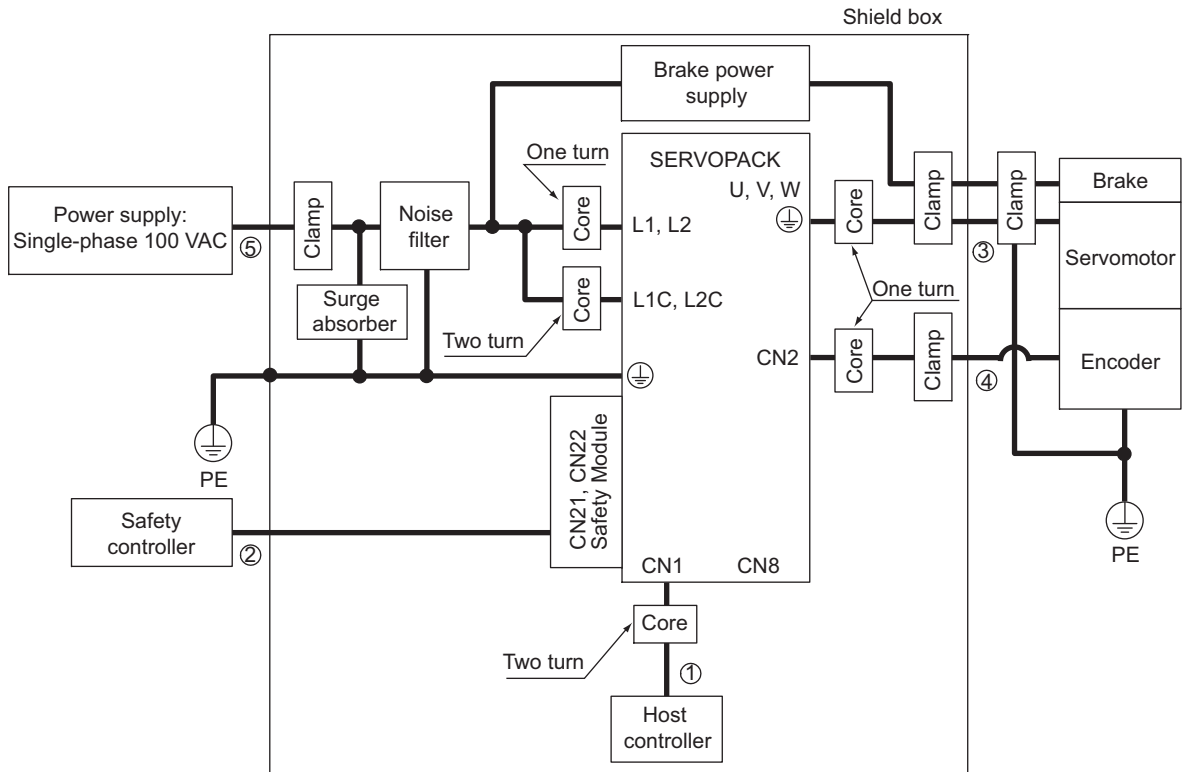

Symbol	Cable Name	Specification
①	I/O signal cable	Shielded cable
②	Safety signal cable	Shielded cable
③	Motor main circuit cable	Shielded cable
④	Encoder cable	Shielded cable
⑤	Main circuit cable	Shielded cable

■ Three-phase 200 V

- SGD7-□□□A0□B (□□□ = R70, R90, 1R6, 2R8) + SGD7-OSA01A

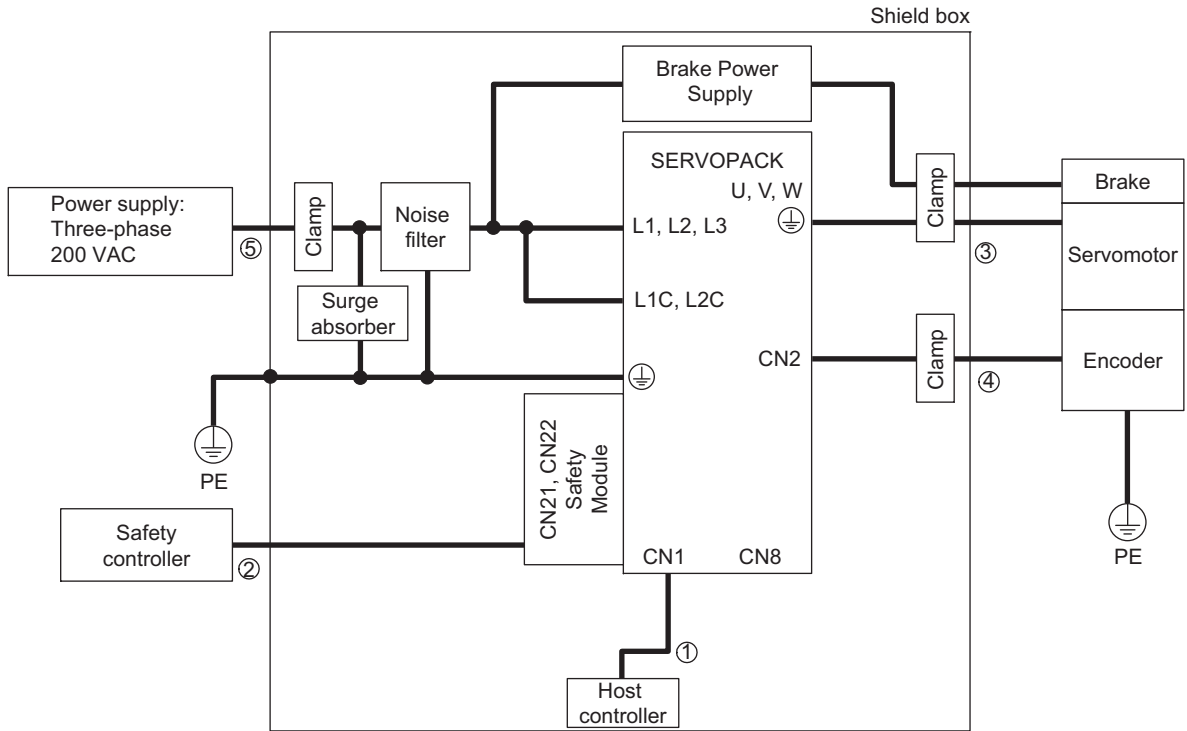

Symbol	Cable Name	Specification
①	I/O signal cable	Shielded cable
②	Safety signal cable	Shielded cable
③	Motor main circuit cable	Shielded cable
④	Encoder cable	Shielded cable
⑤	Main circuit cable	Shielded cable

■ Three-phase 200 V

- SGDV-□□□A0□A (□□□ = R70, R90, 1R6, 2R8, 3R8, 5R5, 7R6) + SGDV-OSA01A

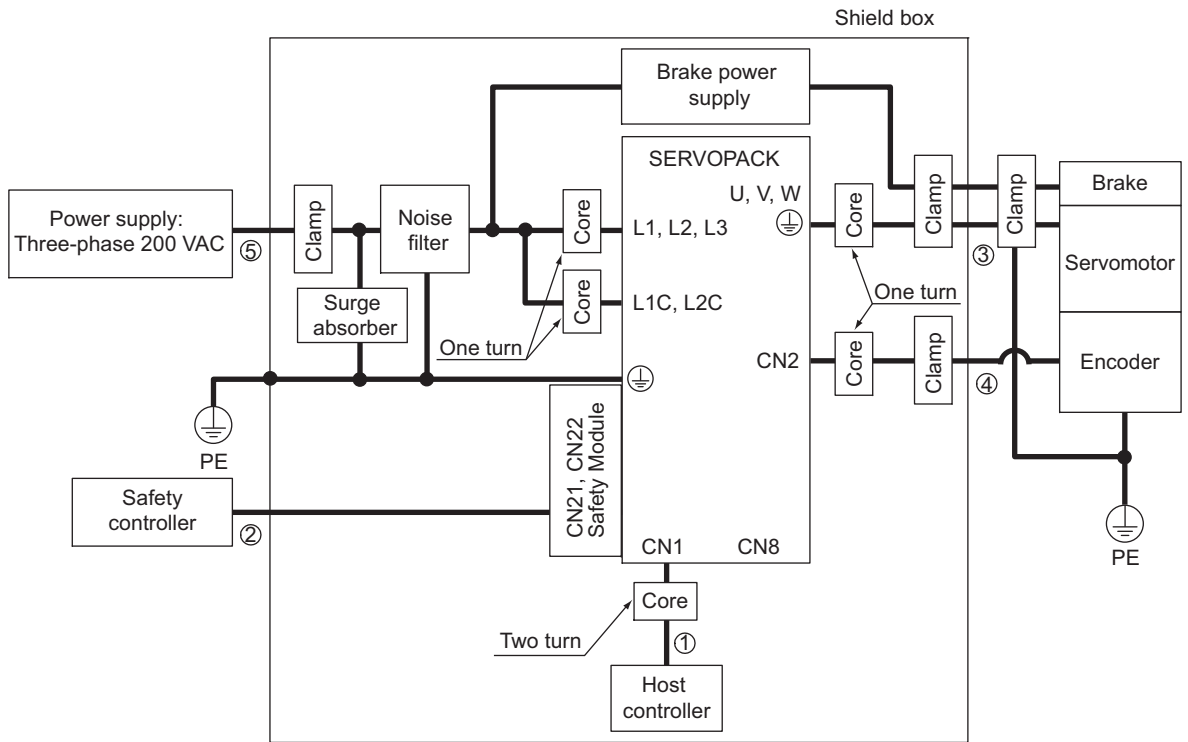

Symbol	Cable Name	Specification
①	I/O signal cable	Shielded cable
②	Safety signal cable	Shielded cable
③	Motor main circuit cable	Shielded cable
④	Encoder cable	Shielded cable
⑤	Main circuit cable	Shielded cable

■ Three-phase 200 V

- SGD7-□□□A0□A (□□□ = 120) + SGD7-OSA01A

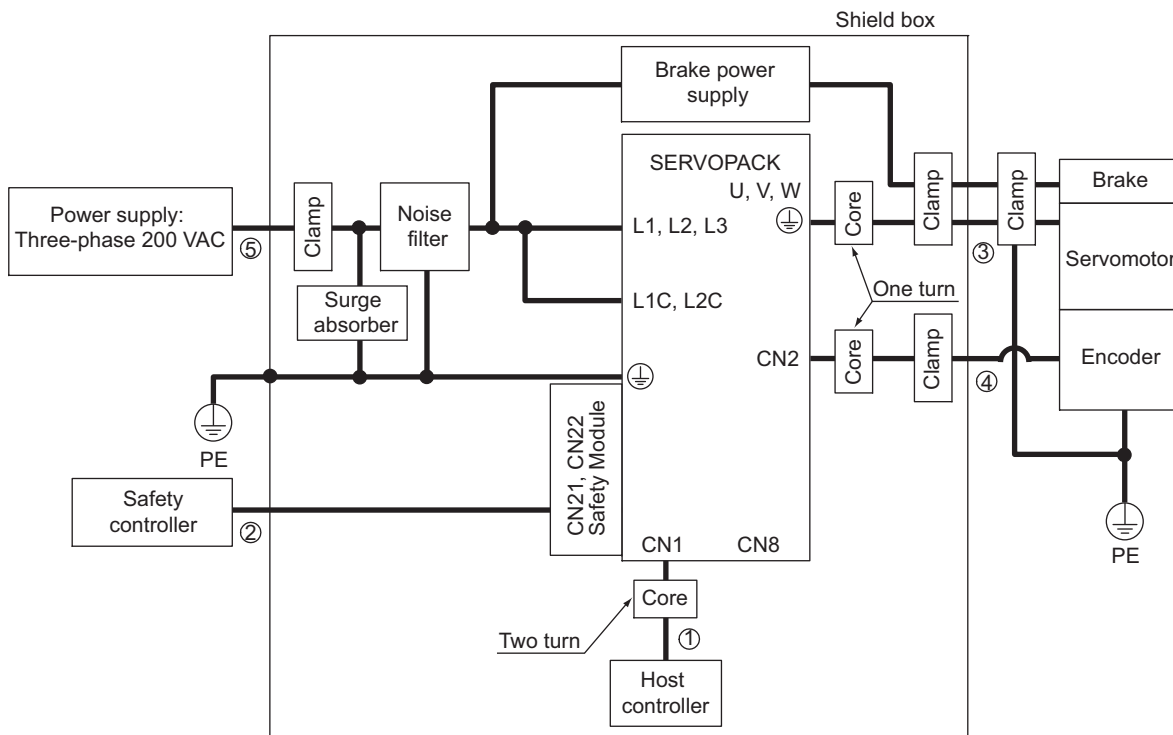

Symbol	Cable Name	Specification
①	I/O signal cable	Shielded cable
②	Safety signal cable	Shielded cable
③	Motor main circuit cable	Shielded cable
④	Encoder cable	Shielded cable
⑤	Main circuit cable	Shielded cable

■ Three-phase 200 V

- SGDV-□□□A0□A (□□□ = 180, 200, 330) + SGDV-OA01A

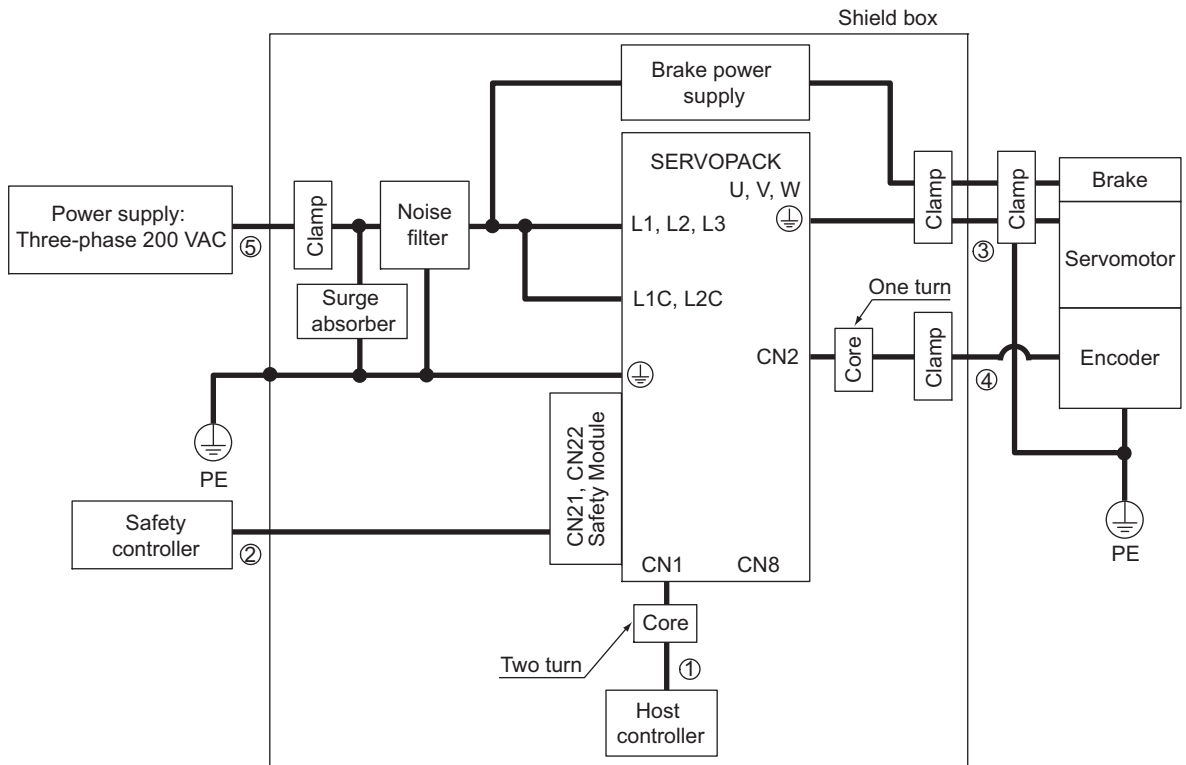

Symbol	Cable Name	Specification
①	I/O signal cable	Shielded cable
②	Safety signal cable	Shielded cable
③	Motor main circuit cable	Shielded cable
④	Encoder cable	Shielded cable
⑤	Main circuit cable	Shielded cable

■ Three-phase 200 V

- SGDV-□□□A0□A (□□□ = 470, 550, 590, 780) + SGDV-OSA01A

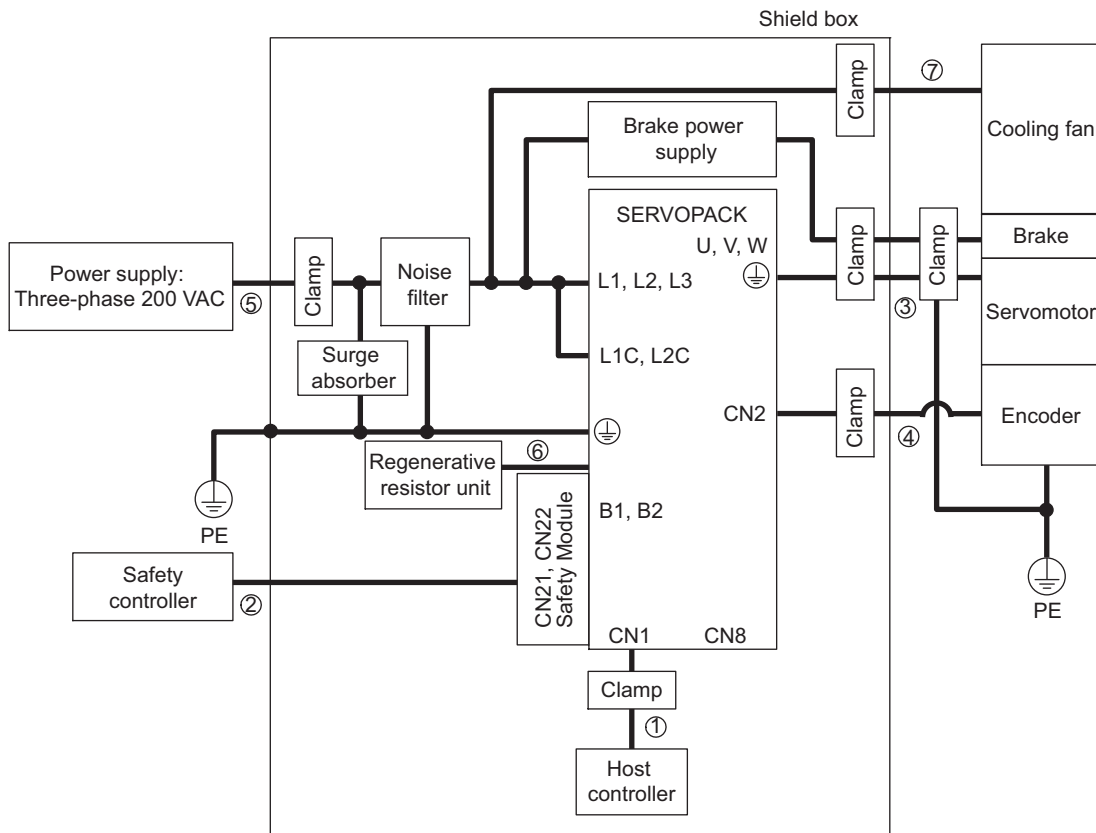

Symbol	Cable Name	Specification
①	I/O signal cable	Shielded cable
②	Safety signal cable	Shielded cable
③	Motor main circuit cable	Shielded cable
④	Encoder cable	Shielded cable
⑤	Main circuit cable	Shielded cable
⑥	Regenerative resistor unit cable	Non-shielded cable
⑦	Cooling fan cable	Shielded cable

■ Three-phase 400 V

- SGDV-□□□D0□A (□□□ = 1R9, 3R5, 5R4, 8R4, 120, 170) + SGDV-OSA01A

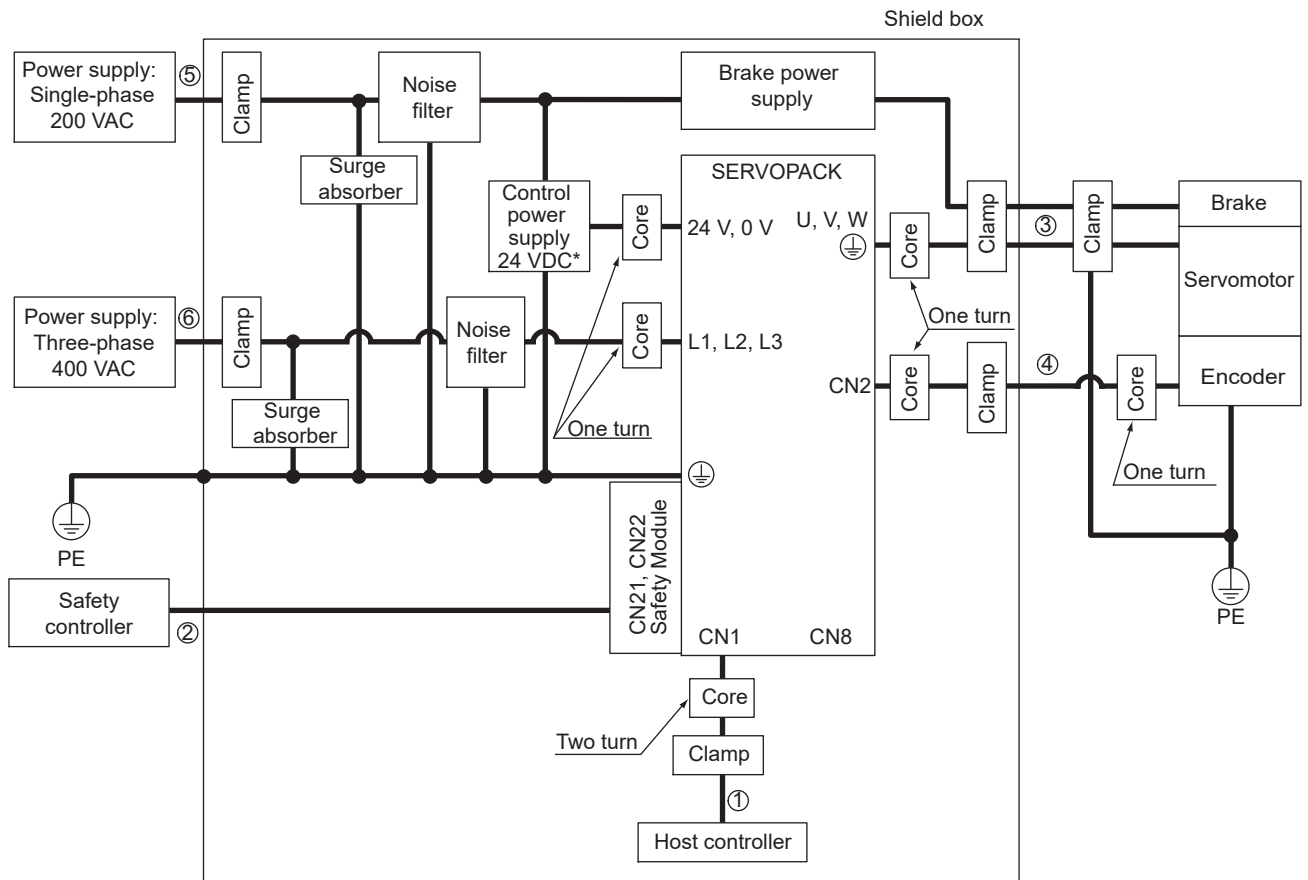

Symbol	Cable Name	Specification
①	I/O signal cable	Shielded cable
②	Safety signal cable	Shielded cable
③	Motor main circuit cable	Shielded cable
④	Encoder cable	Shielded cable
⑤	Control power cable	Shielded cable
⑥	Main circuit cable	Shielded cable

* Products that have received CE marking are recommended for the 24 VDC power supply.

■ Three-phase 400 V

- SGDV-□□□D0□A (□□□ = 210, 260, 280, 370) + SGDV-OSA01A

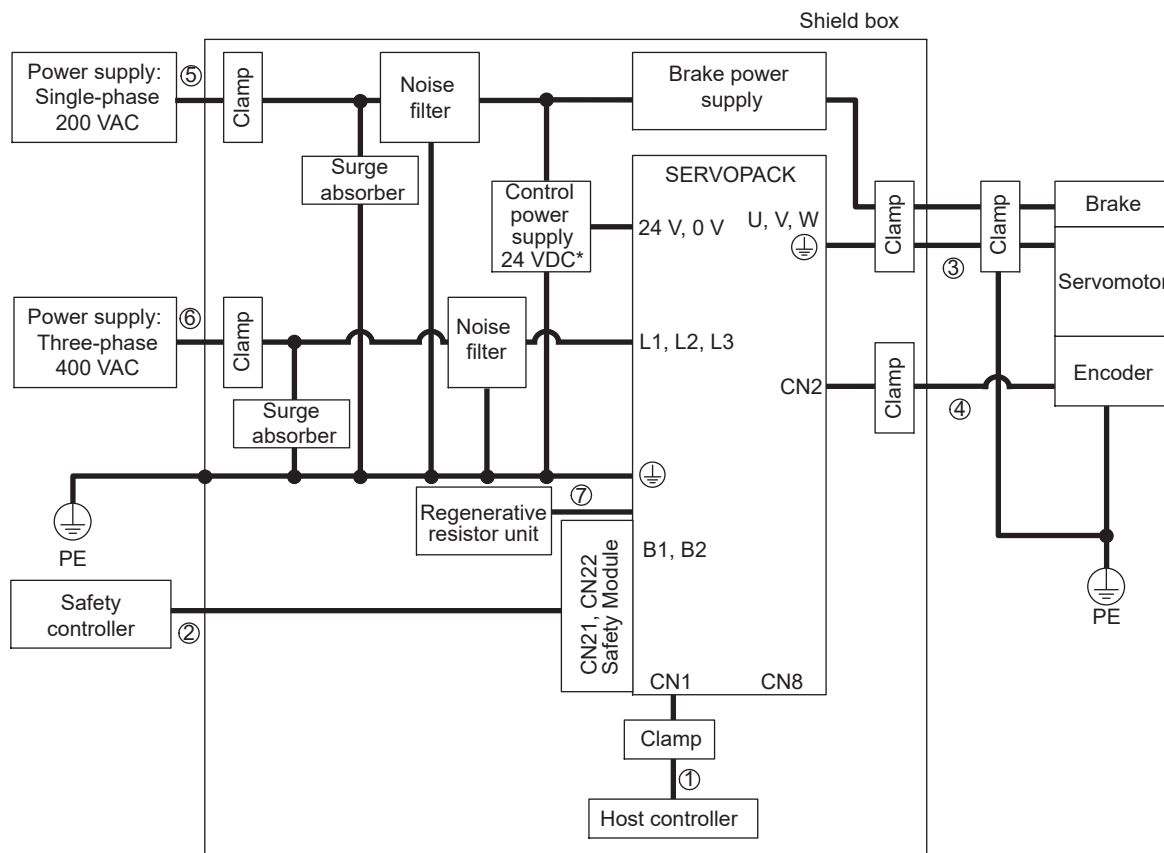

Symbol	Cable Name	Specification
①	I/O signal cable	Shielded cable
②	Safety signal cable	Shielded cable
③	Motor main circuit cable	Shielded cable
④	Encoder cable	Shielded cable
⑤	Control power cable	Shielded cable
⑥	Main circuit cable	Shielded cable
⑦	Regenerative resistor unit cable	Non-shielded cable

* Products that have received CE marking are recommended for the 24 VDC power supply.

(2) SGD V-□□□□1□□ (M-II Communications Reference Models)

■ Single-phase 100 V

- SGD V-□□□F1□A (□□□ = R70, R90, 2R1, 2R8) + SGD V-OSA01A

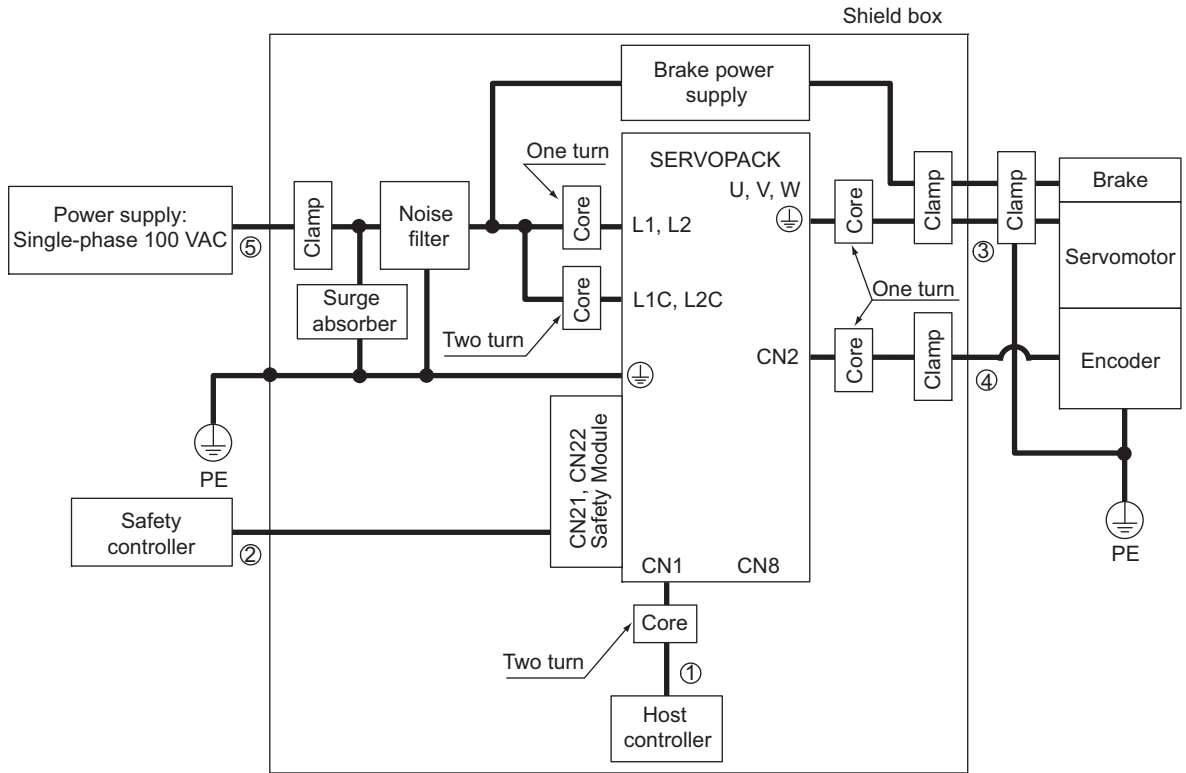

Symbol	Cable Name	Specification
①	I/O signal cable	Shielded cable
②	Safety signal cable	Shielded cable
③	Motor main circuit cable	Shielded cable
④	Encoder cable	Shielded cable
⑤	Main circuit cable	Shielded cable

■ Three-phase 200 V

- SGDV-□□□A1□B (□□□ = R70, R90, 1R6, 2R8) + SGDV-OSA01A

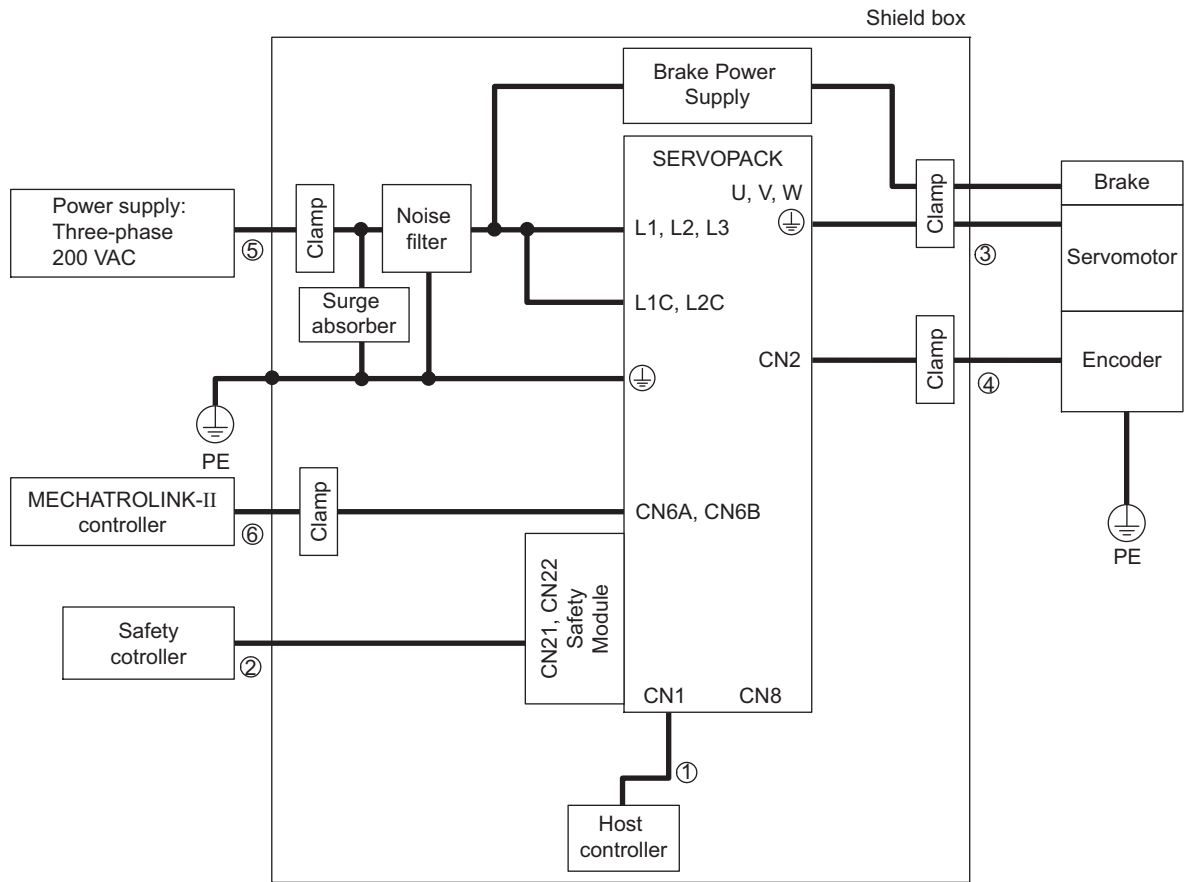

Symbol	Cable Name	Specification
①	I/O signal cable	Shielded cable
②	Safety signal cable	Shielded cable
③	Motor main circuit cable	Shielded cable
④	Encoder cable	Shielded cable
⑤	Main circuit cable	Shielded cable
⑥	MECHATROLINK-II communication cable	Shielded cable

■ Three-phase 200 V

- SGDV-□□□A1□A (□□□ = R70, R90, 1R6, 2R8, 3R8, 5R5, 7R6) + SGDV-OSA01A

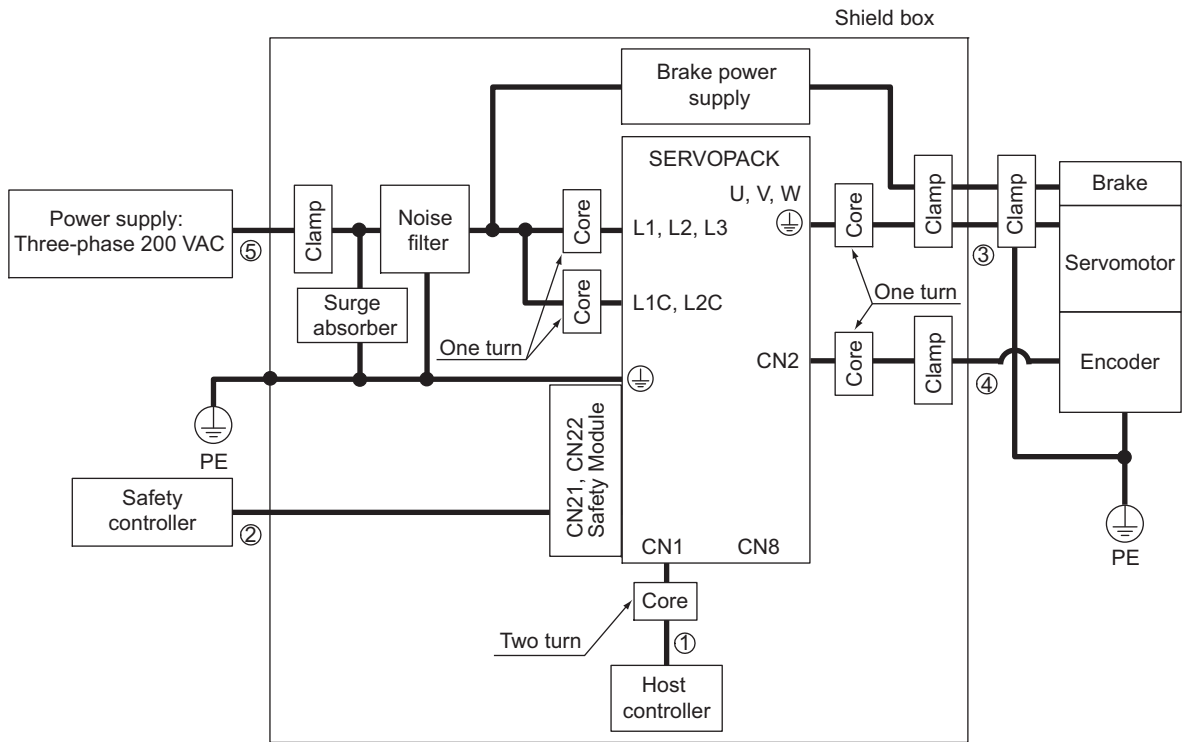

Symbol	Cable Name	Specification
①	I/O signal cable	Shielded cable
②	Safety signal cable	Shielded cable
③	Motor main circuit cable	Shielded cable
④	Encoder cable	Shielded cable
⑤	Main circuit cable	Shielded cable

■ Three-phase 200 V

- SGD7-□□□A1□A (□□□ = 120) + SGD7-OSA01A

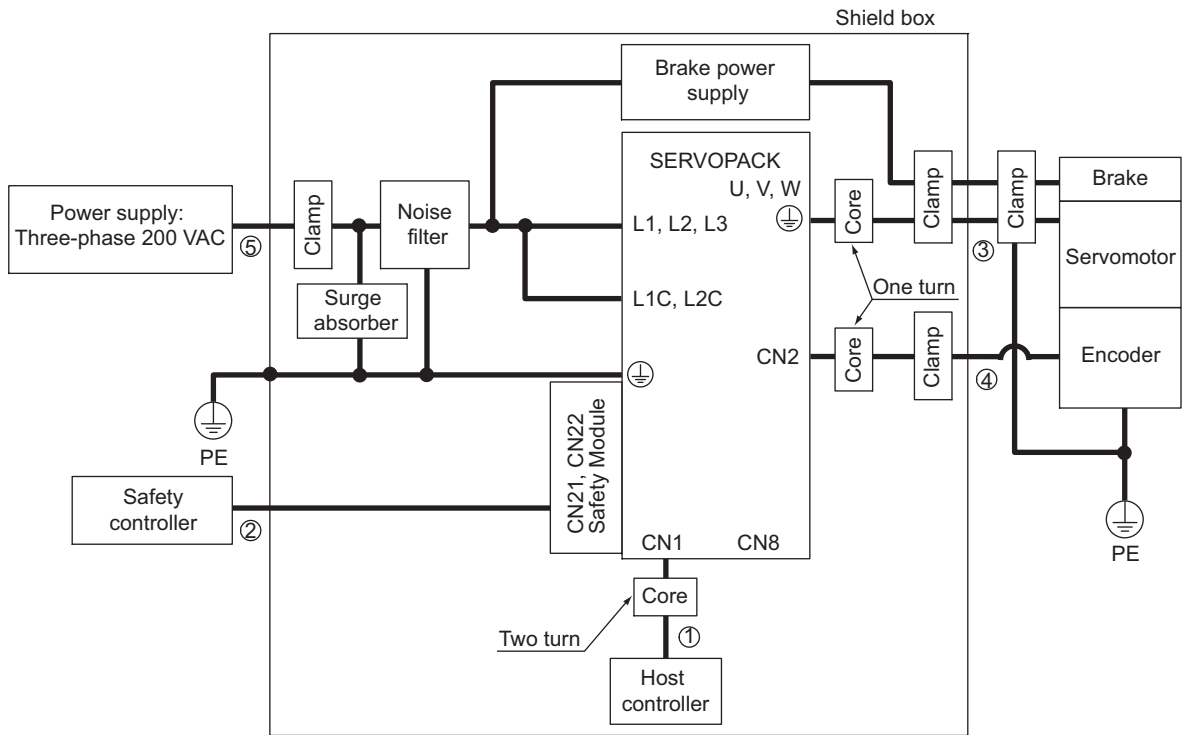

Symbol	Cable Name	Specification
①	I/O signal cable	Shielded cable
②	Safety signal cable	Shielded cable
③	Motor main circuit cable	Shielded cable
④	Encoder cable	Shielded cable
⑤	Main circuit cable	Shielded cable

■ Three-phase 200 V

- SGDV-□□□A1□A (□□□ = 180, 200, 330) + SGDV-OSA01A

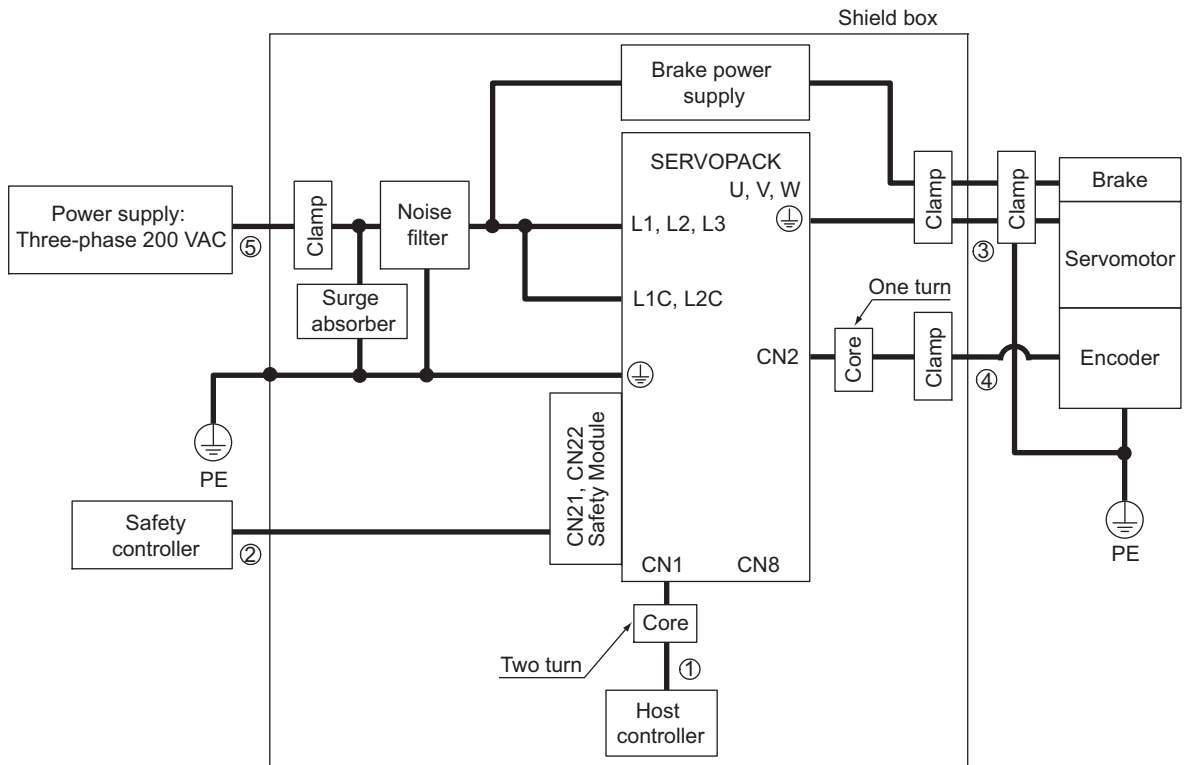

Symbol	Cable Name	Specification
①	I/O signal cable	Shielded cable
②	Safety signal cable	Shielded cable
③	Motor main circuit cable	Shielded cable
④	Encoder cable	Shielded cable
⑤	Main circuit cable	Shielded cable

■ Three-phase 200 V

- SGDV-□□□A1□A (□□□ = 470, 550, 590, 780) + SGDV-OSA01A

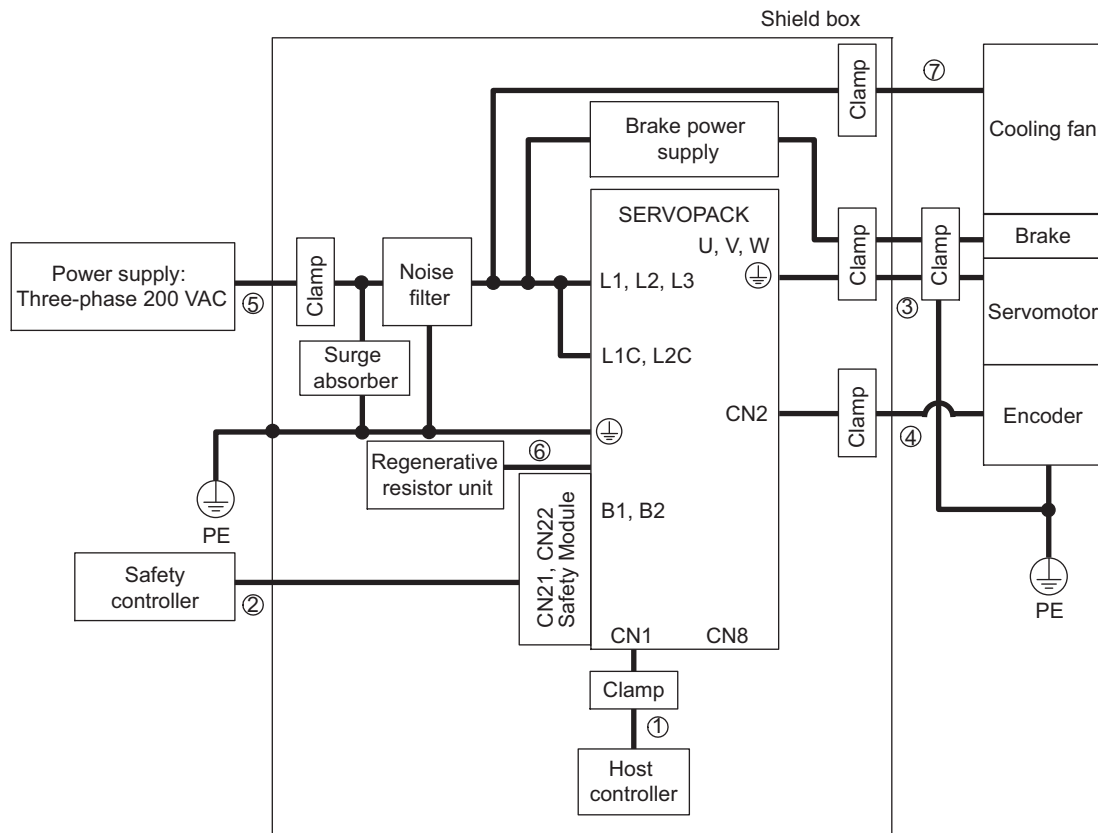

Symbol	Cable Name	Specification
①	I/O signal cable	Shielded cable
②	Safety signal cable	Shielded cable
③	Motor main circuit cable	Shielded cable
④	Encoder cable	Shielded cable
⑤	Main circuit cable	Shielded cable
⑥	Regenerative resistor unit cable	Non-shielded cable
⑦	Cooling fan cable	Shielded cable

■ Three-phase 400 V

- SGDV-□□□D1□A (□□□ = 1R9, 3R5, 5R4, 8R4, 120, 170) + SGDV-OSA01A

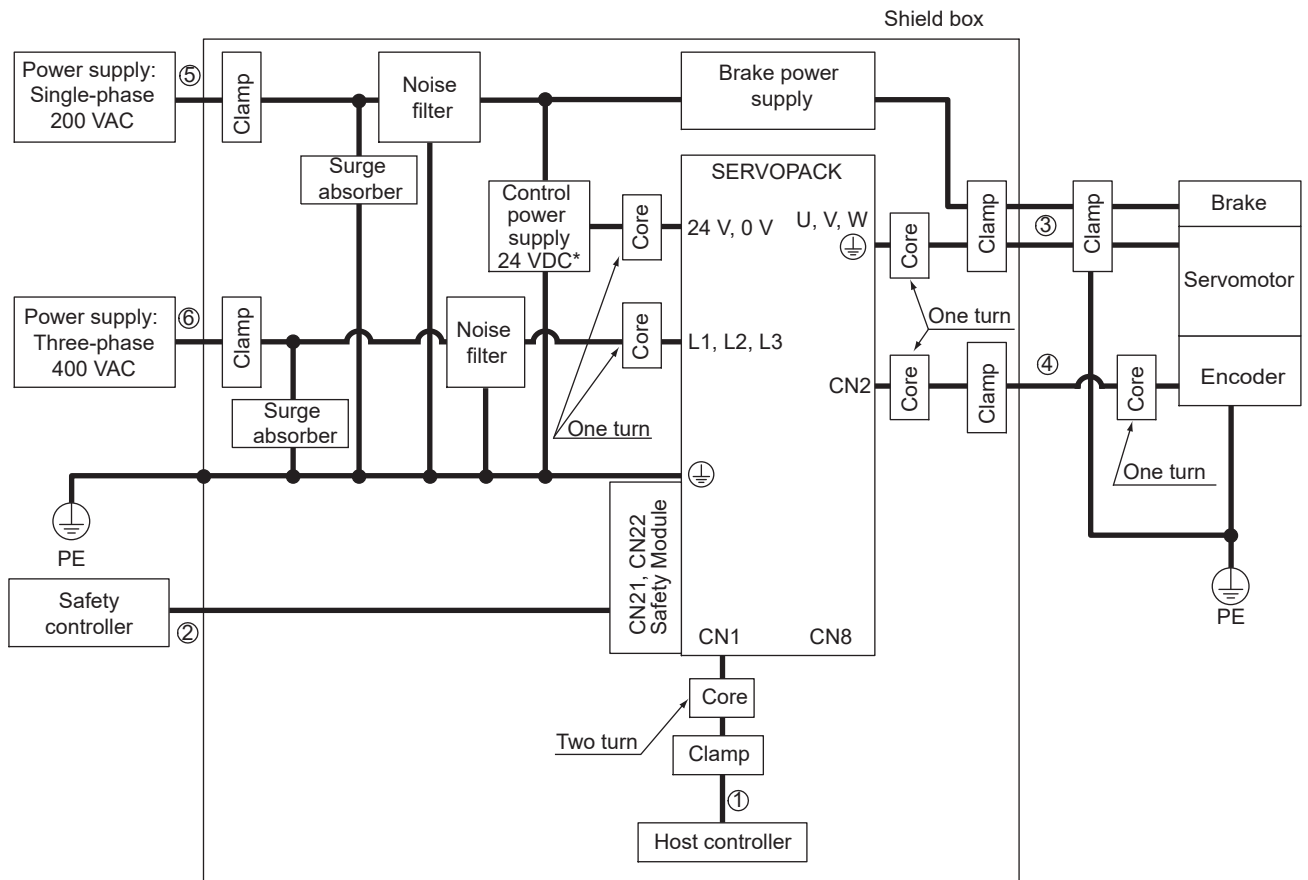

Symbol	Cable Name	Specification
①	I/O signal cable	Shielded cable
②	Safety signal cable	Shielded cable
③	Motor main circuit cable	Shielded cable
④	Encoder cable	Shielded cable
⑤	Control power cable	Shielded cable
⑥	Main circuit cable	Shielded cable

* Products that have received CE marking are recommended for the 24 VDC power supply.

■ Three-phase 400 V

- SGDV-□□□D1□A (□□□ = 210, 260, 280, 370) + SGDV-OSA01A

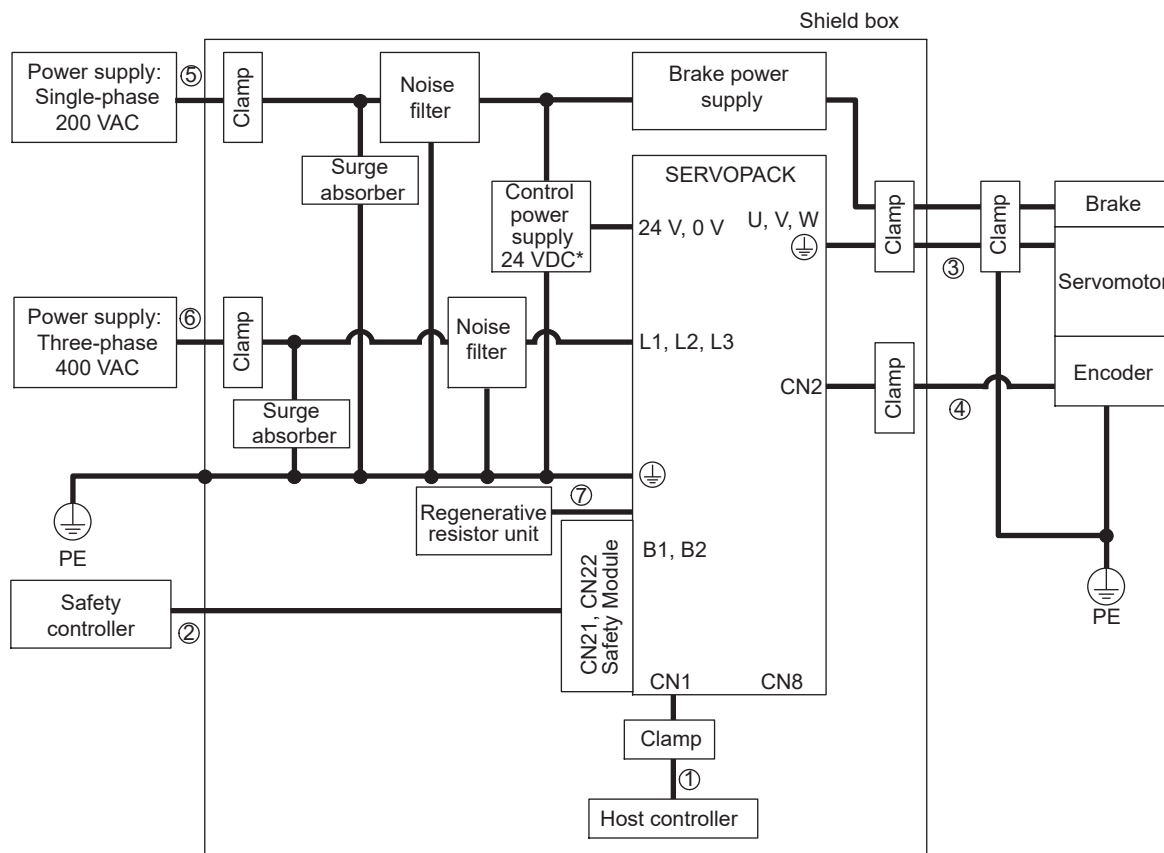

Symbol	Cable Name	Specification
①	I/O signal cable	Shielded cable
②	Safety signal cable	Shielded cable
③	Motor main circuit cable	Shielded cable
④	Encoder cable	Shielded cable
⑤	Control power cable	Shielded cable
⑥	Main circuit cable	Shielded cable
⑦	Regenerative resistor unit cable	Non-shielded cable

* Products that have received CE marking are recommended for the 24 VDC power supply.

(3) SGDV-□□□□2□□ (M-III Communications Reference Models)

■ Single-phase 100 V

- SGDV-□□□F2□A (□□□ = R70, R90, 2R1, 2R8) + SGDV-OSA01A

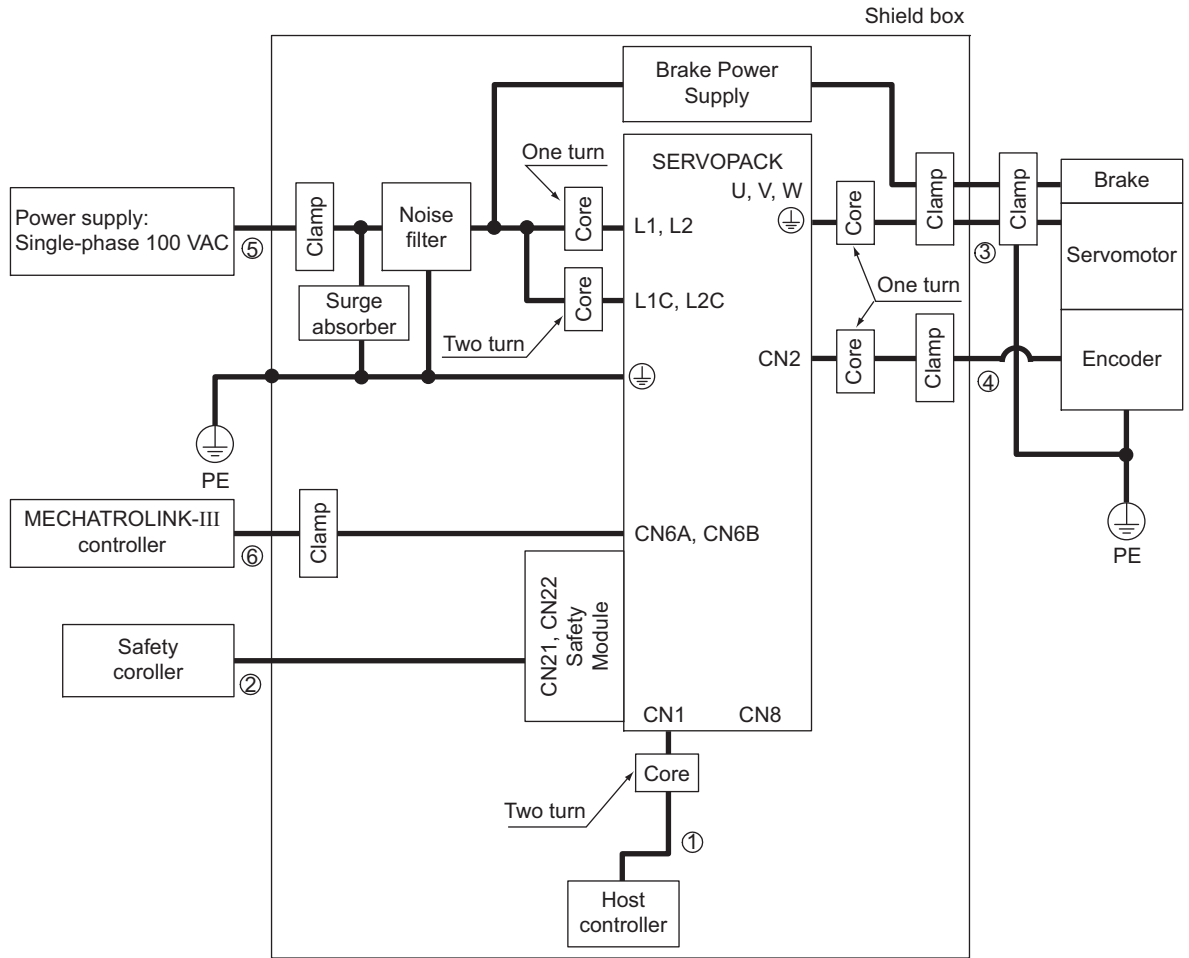

Symbol	Cable Name	Specification
①	I/O signal cable	Shielded cable
②	Safety signal cable	Shielded cable
③	Motor main circuit cable	Shielded cable
④	Encoder cable	Shielded cable
⑤	Main circuit cable	Shielded cable
⑥	MECHATROLINK-III communication cable	Shielded cable

■ Three-phase 200 V

- SGDV-□□□A2□B (□□□ = R70, R90, 2R6, 2R8) + SGDV-OSA01A

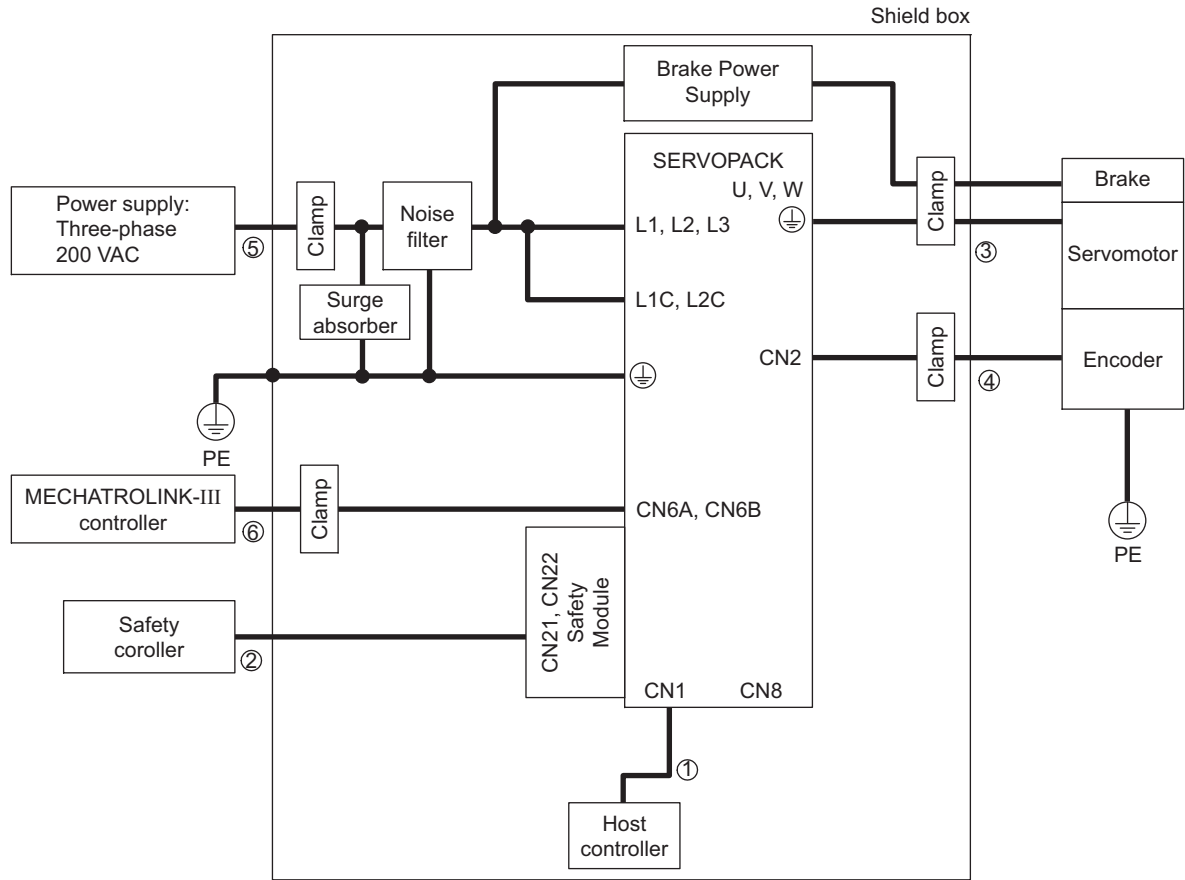

Symbol	Cable Name	Specification
①	I/O signal cable	Shielded cable
②	Safety signal cable	Shielded cable
③	Motor main circuit cable	Shielded cable
④	Encoder cable	Shielded cable
⑤	Main circuit cable	Shielded cable
⑥	MECHATROLINK-III communication cable	Shielded cable

■ Three-phase 200 V

- SGDV-□□□A2□A (□□□ = R70, R90, 1R6, 2R8, 3R8, 5R5, 7R6) + SGDV-OSA01A

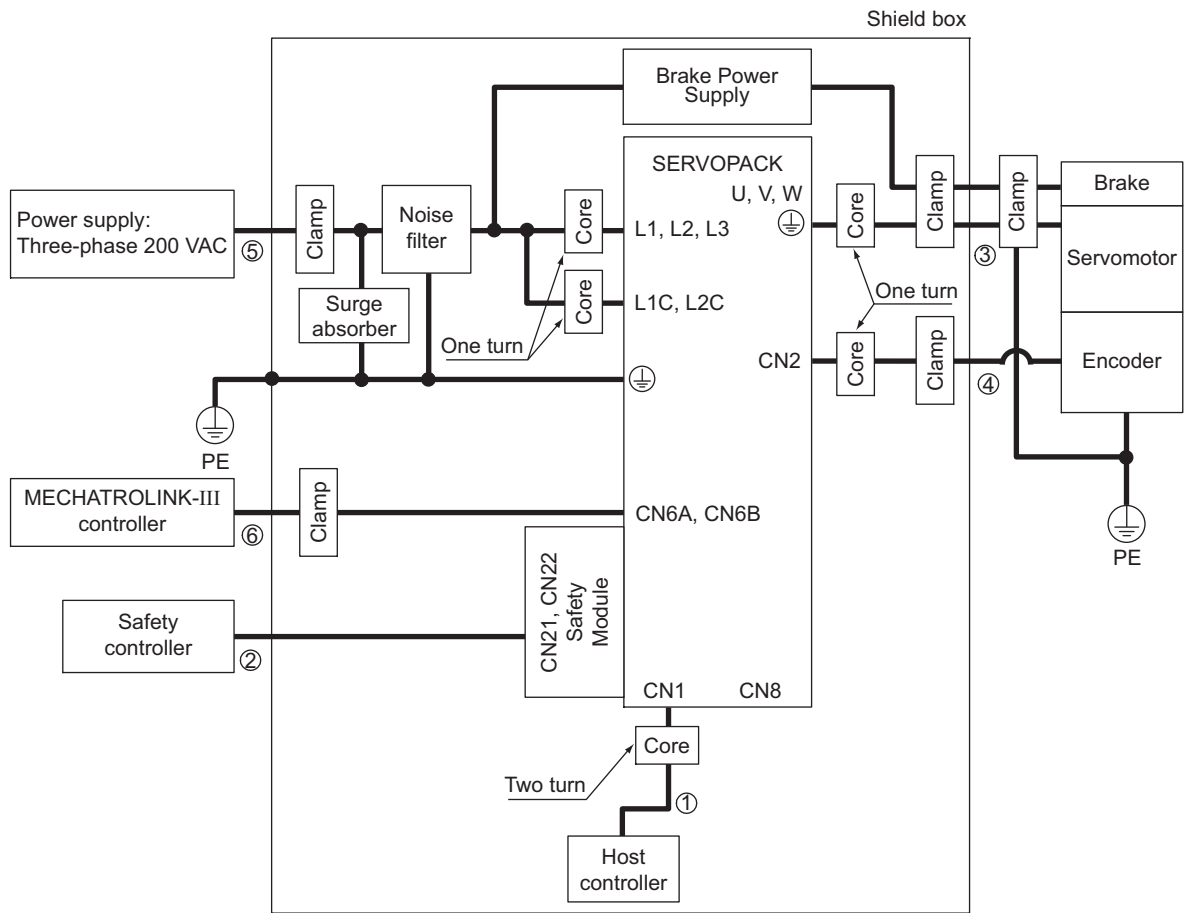

Symbol	Cable Name	Specification
①	I/O signal cable	Shielded cable
②	Safety signal cable	Shielded cable
③	Motor main circuit cable	Shielded cable
④	Encoder cable	Shielded cable
⑤	Main circuit cable	Shielded cable
⑥	MECHATROLINK-III communication cable	Shielded cable

■ Three-phase 200 V

- SGDV-□□□A2□A (□□□ = 120) + SGDV-OSA01A

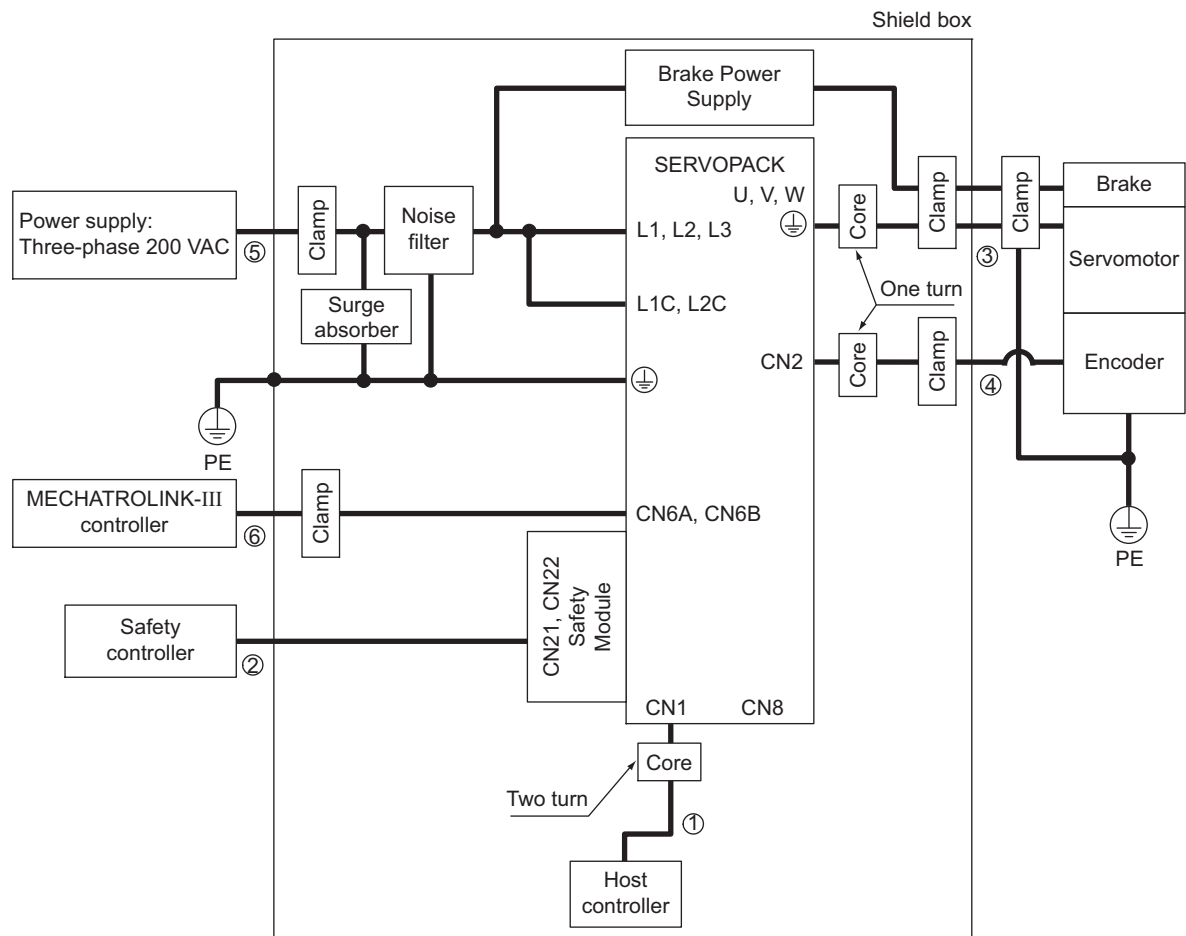

Symbol	Cable Name	Specification
①	I/O signal cable	Shielded cable
②	Safety signal cable	Shielded cable
③	Motor main circuit cable	Shielded cable
④	Encoder cable	Shielded cable
⑤	Main circuit cable	Shielded cable
⑥	MECHATROLINK-III communication cable	Shielded cable

■ Three-phase 200 V

- SGDV-□□□A2□A (□□□ = 180, 200, 330) + SGDV-OSA01A

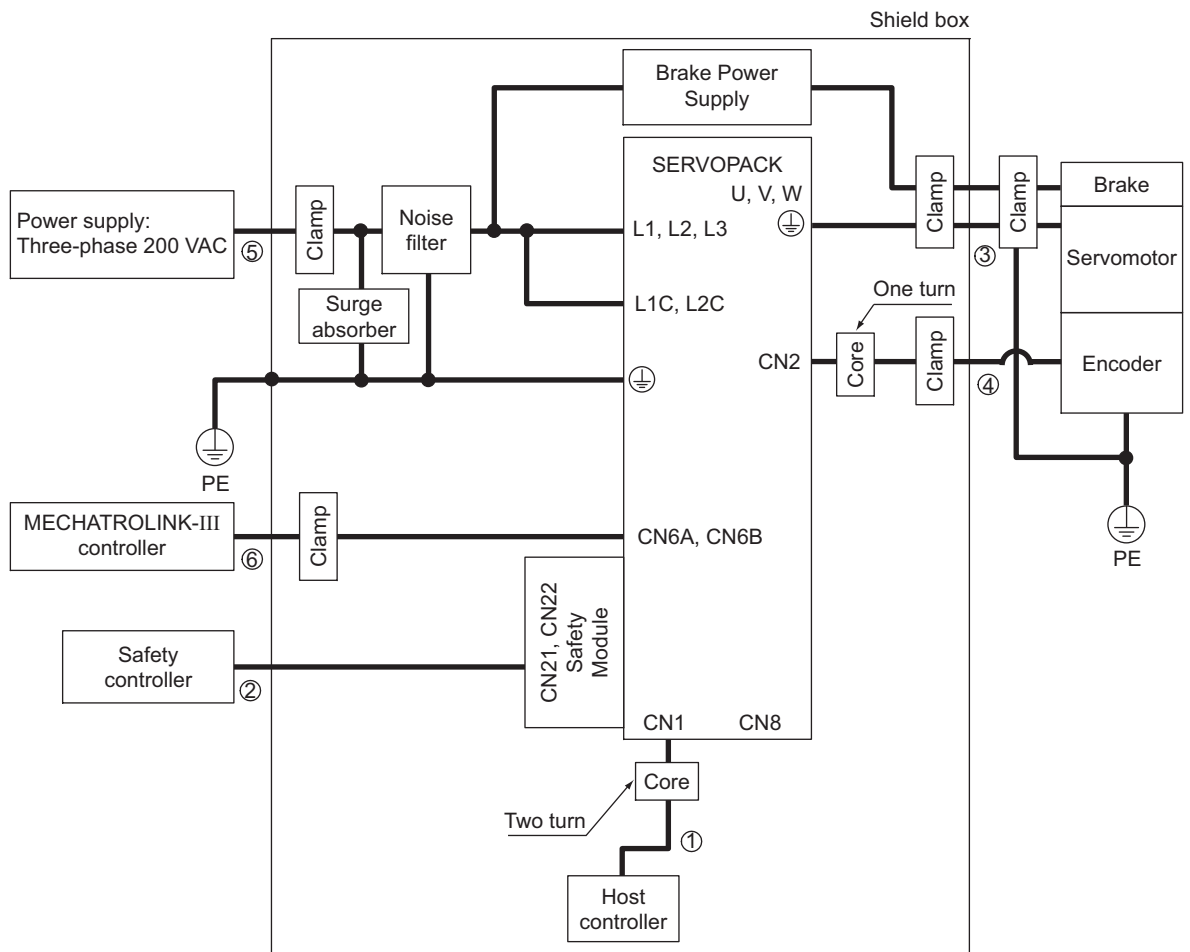

Symbol	Cable Name	Specification
①	I/O signal cable	Shielded cable
②	Safety signal cable	Shielded cable
③	Motor main circuit cable	Shielded cable
④	Encoder cable	Shielded cable
⑤	Main circuit cable	Shielded cable
⑥	MECHATROLINK-III communication cable	Shielded cable

■ Three-phase 200 V

- SGDV-□□□A2□A (□□□ = 470, 550, 590, 780) + SGDV-OSA01A

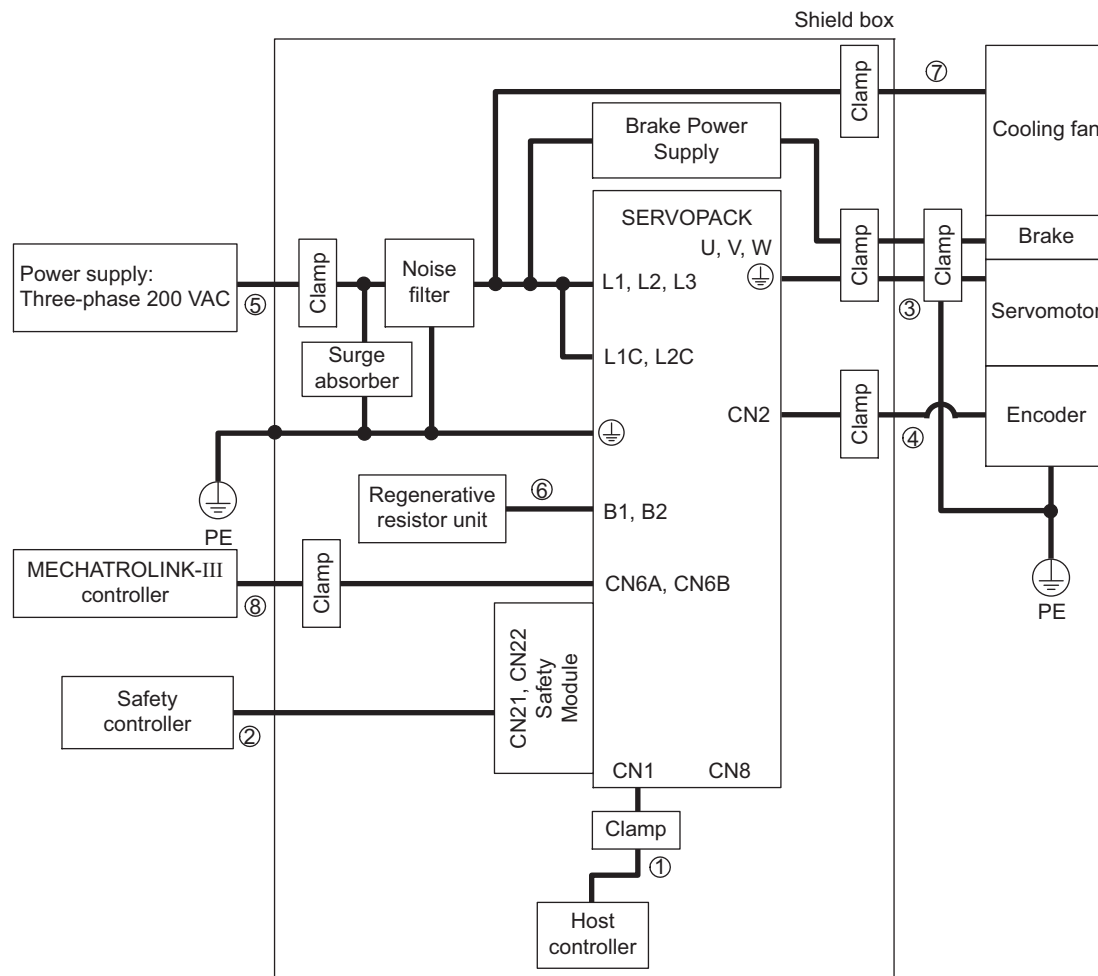

Symbol	Cable Name	Specification
①	I/O signal cable	Shielded cable
②	Safety signal cable	Shielded cable
③	Motor main circuit cable	Shielded cable
④	Encoder cable	Shielded cable
⑤	Main circuit cable	Shielded cable
⑥	Regenerative resistor unit cable	Non-shielded cable
⑦	Cooling fan cable	Shielded cable
⑧	MECHATROLINK-III communication cable	Shielded cable

■ Three-phase 400 V

- SGDV-□□□D2□A (□□□ = 1R9, 3R5, 5R4, 8R4, 120, 170) + SGDV-OSA01A

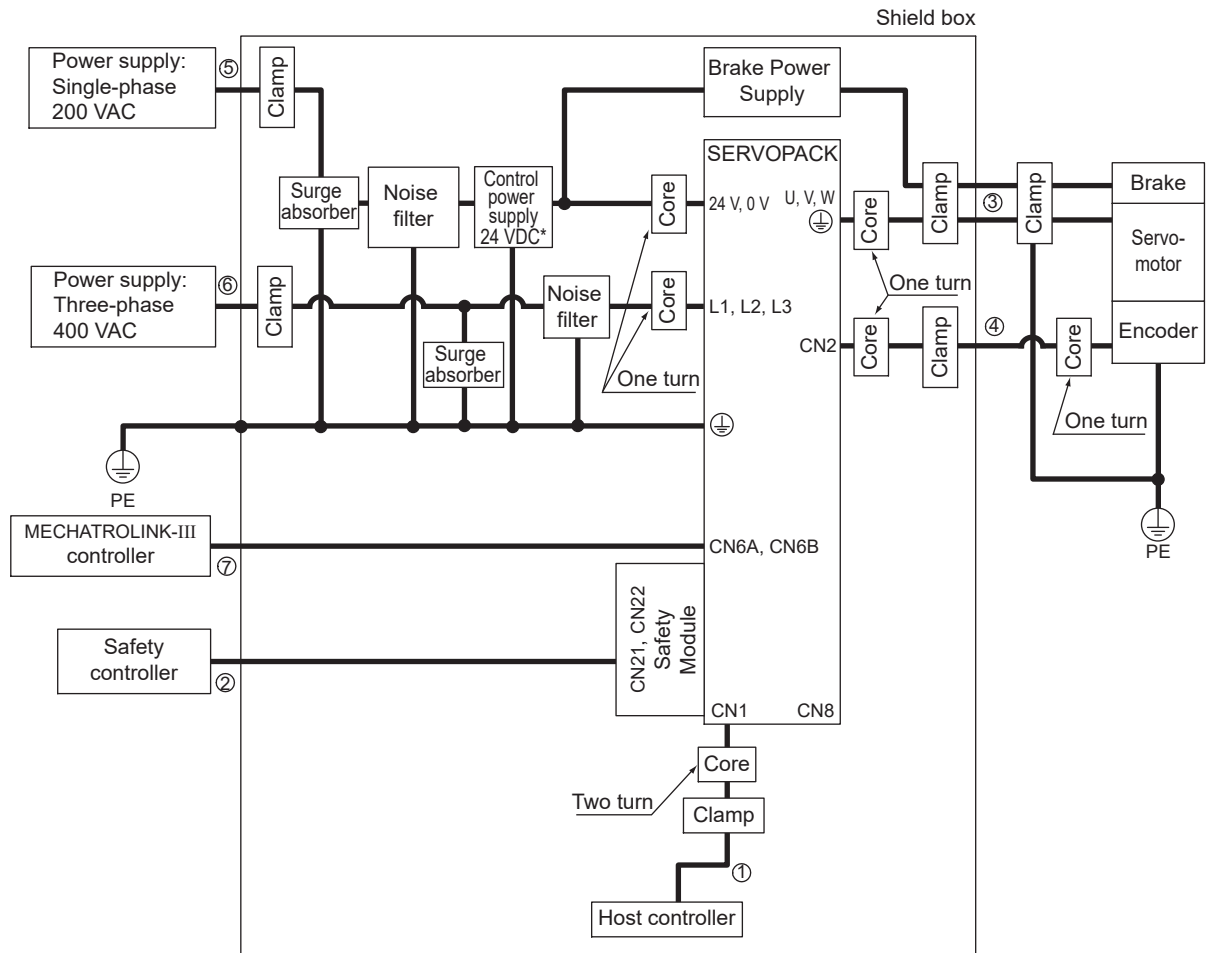

Symbol	Cable Name	Specification
①	I/O signal cable	Shielded cable
②	Safety signal cable	Shielded cable
③	Motor main circuit cable	Shielded cable
④	Encoder cable	Shielded cable
⑤	Control power cable	Shielded cable
⑥	Main circuit cable	Shielded cable
⑦	MECHATROLINK-III communication cable	Shielded cable

* Products that have received CE marking are recommended for the 24 VDC power supply.

■ Three-phase 400 V

- SGDV-□□□D2□A (□□□ = 210, 260, 280, 370) + SGDV-OSA01A

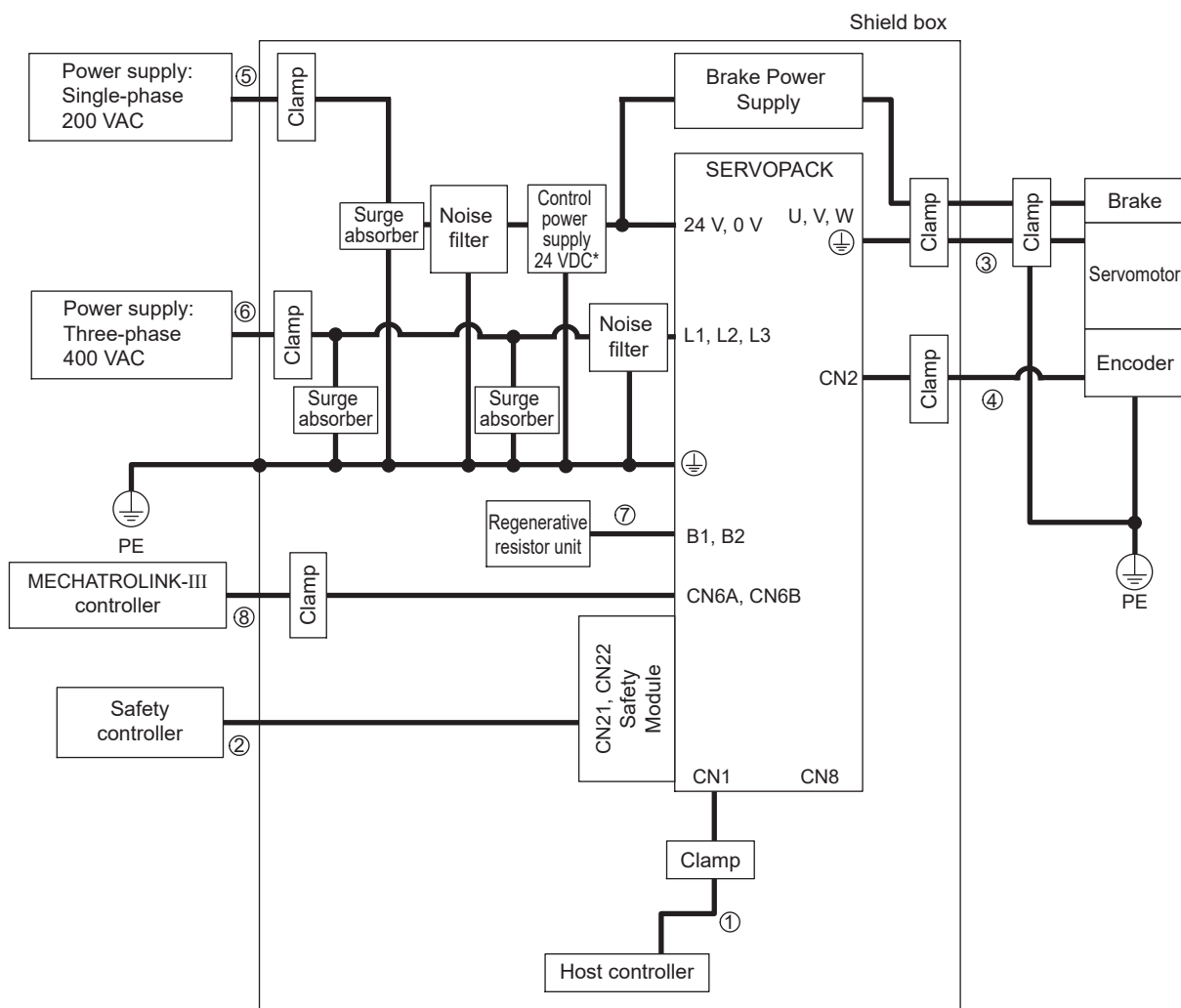

Symbol	Cable Name	Specification
①	I/O signal cable	Shielded cable
②	Safety signal cable	Shielded cable
③	Motor main circuit cable	Shielded cable
④	Encoder cable	Shielded cable
⑤	Control power cable	Shielded cable
⑥	Main circuit cable	Shielded cable
⑦	Regenerative resistor unit cable	Non-shielded cable
⑧	MECHATROLINK-III communication cable	Shielded cable

* Products that have received CE marking are recommended for the 24 VDC power supply.

(4) SGDV-□□□□E□A (Command Option Attachable Type)

■ Single-phase 100 V

- SGDV-□□□FE□A (□□□ = R70, R90, 2R1, 2R8) + SGDV-OSA01A

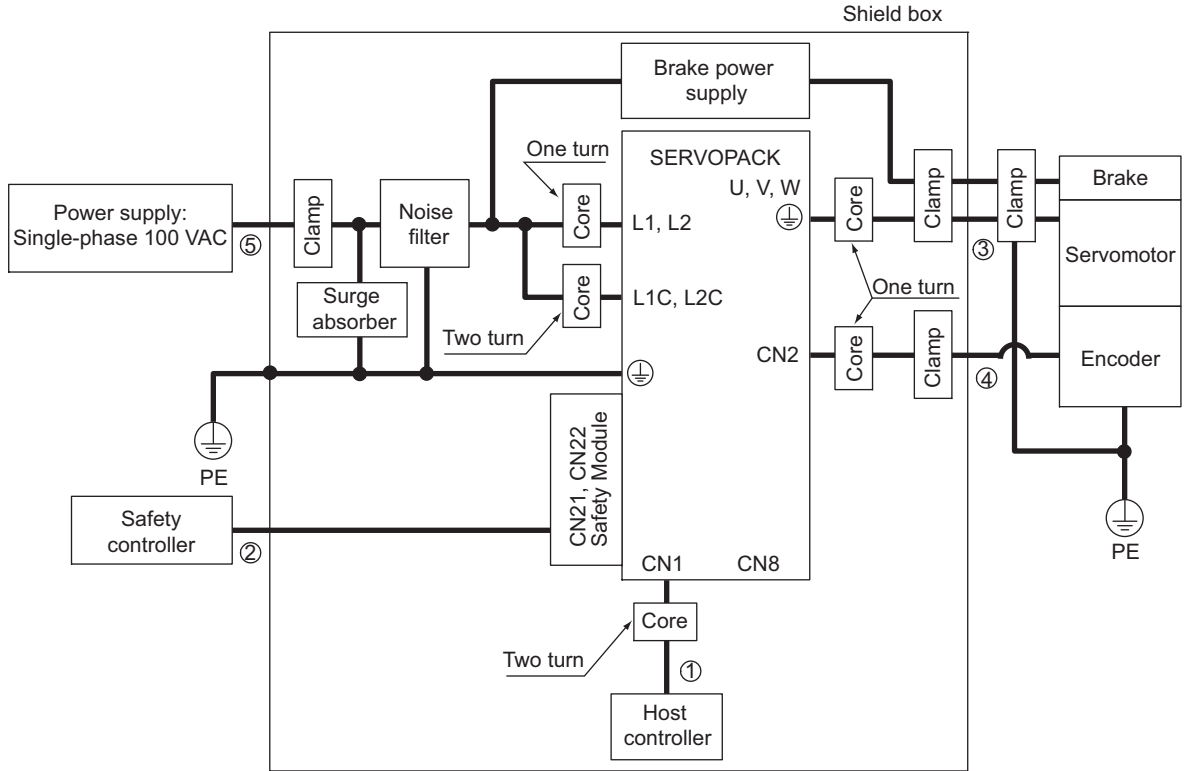

Symbol	Cable Name	Specification
①	I/O signal cable	Shielded cable
②	Safety signal cable	Shielded cable
③	Motor main circuit cable	Shielded cable
④	Encoder cable	Shielded cable
⑤	Main circuit cable	Shielded cable

■ Three-phase 200 V

- SGDV-□□□AE□A (□□□ = R70, R90, 1R6, 2R8, 3R8, 5R5, 7R6) + SGDV-OSA01A

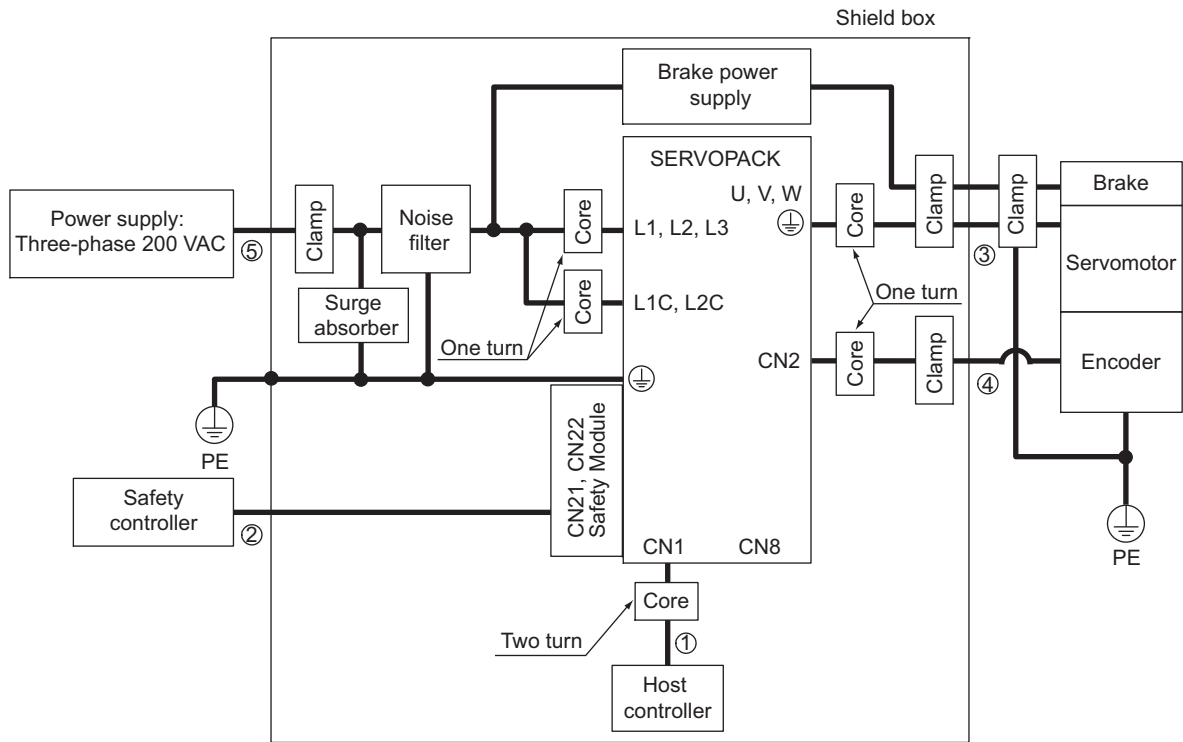

Symbol	Cable Name	Specification
①	I/O signal cable	Shielded cable
②	Safety signal cable	Shielded cable
③	Motor main circuit cable	Shielded cable
④	Encoder cable	Shielded cable
⑤	Main circuit cable	Shielded cable

■ Three-phase 200 V

- SGDV-□□□AE□A (□□□ = 120) + SGDV-OSA01A

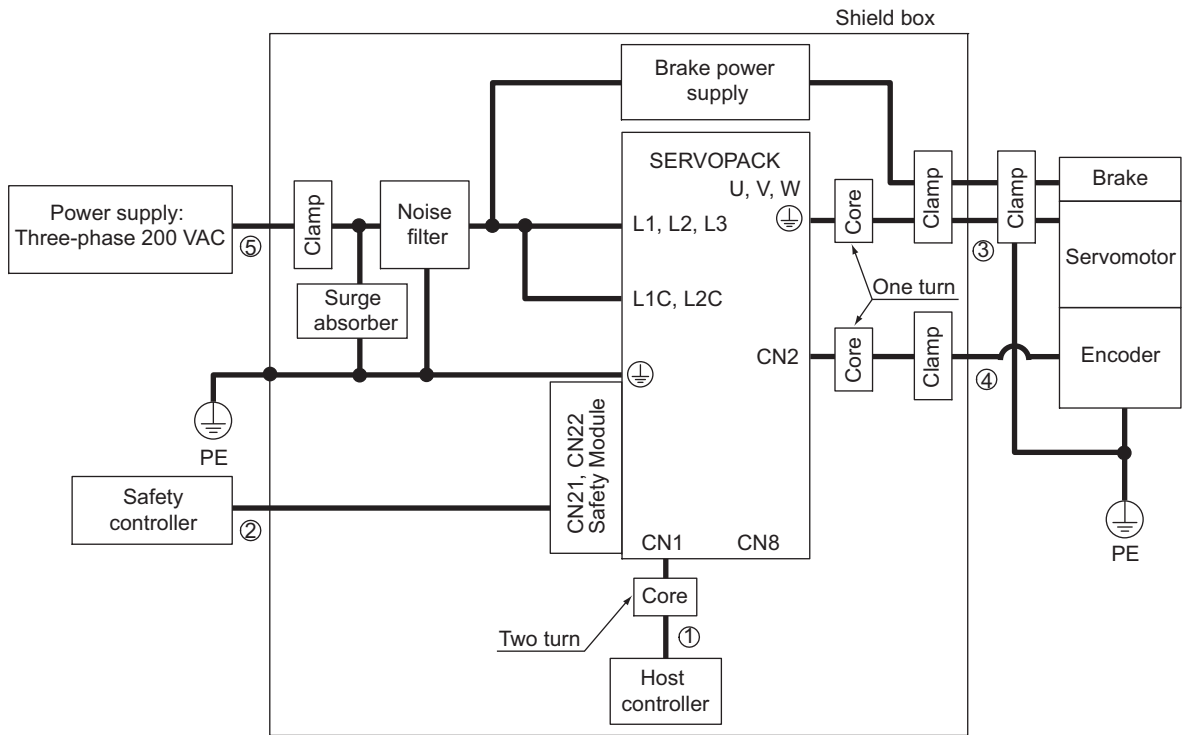

Symbol	Cable Name	Specification
①	I/O signal cable	Shielded cable
②	Safety signal cable	Shielded cable
③	Motor main circuit cable	Shielded cable
④	Encoder cable	Shielded cable
⑤	Main circuit cable	Shielded cable

■ Three-phase 200 V

- SGD7-□□□AE□A (□□□ = 180, 200, 330) + SGD7-OSA01A

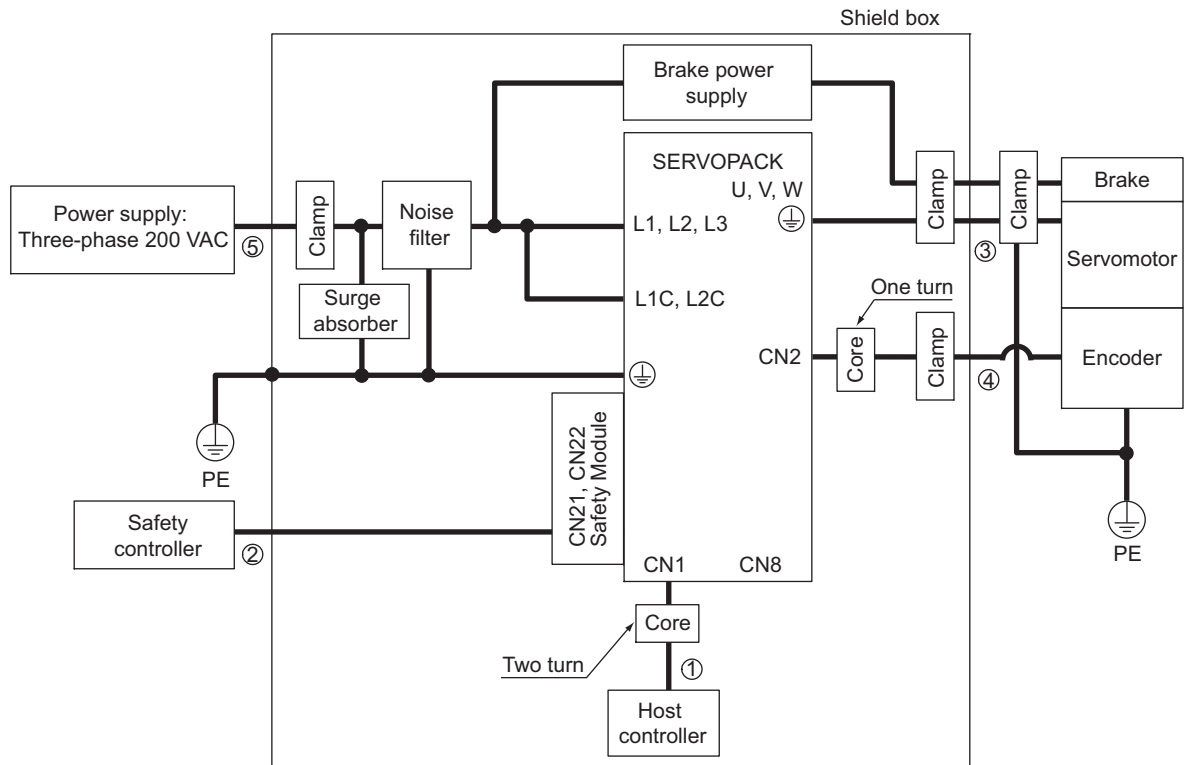

Symbol	Cable Name	Specification
①	I/O signal cable	Shielded cable
②	Safety signal cable	Shielded cable
③	Motor main circuit cable	Shielded cable
④	Encoder cable	Shielded cable
⑤	Main circuit cable	Shielded cable

■ Three-phase 200 V

- SGD V-□□□AE□□ (□□□ = 470, 550, 590, 780) + SGD V-OSA01A

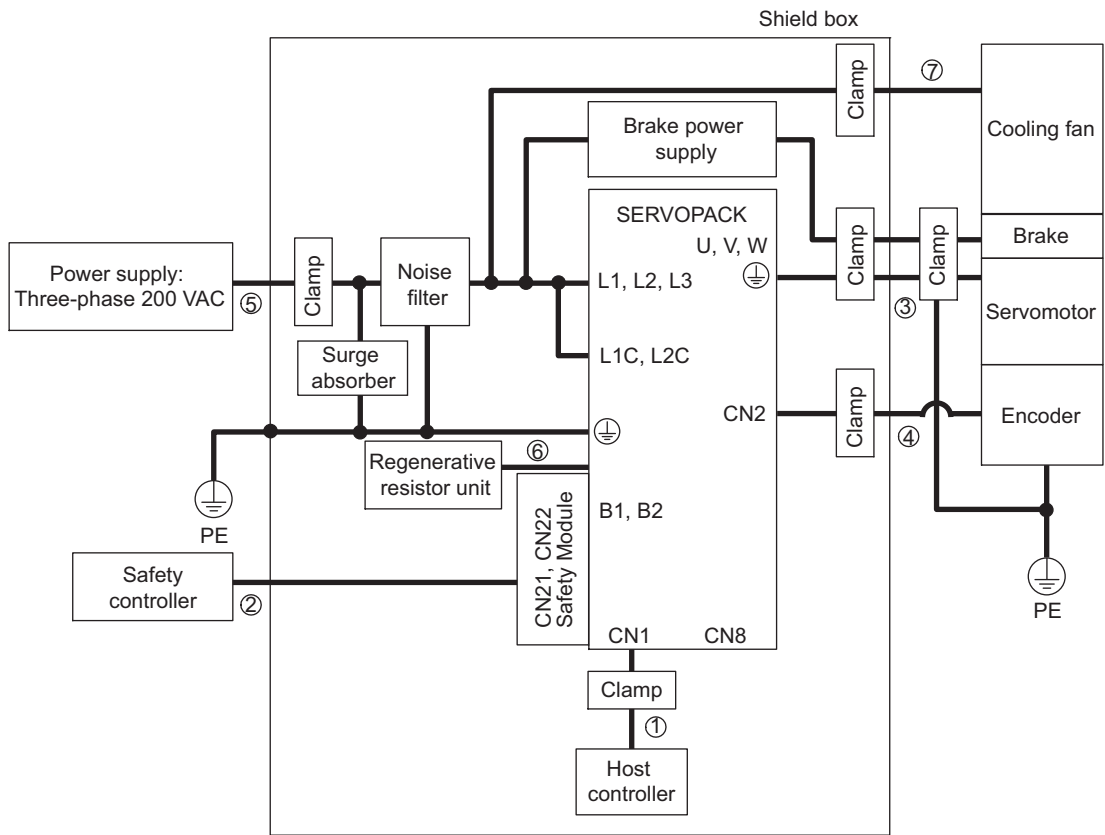

Symbol	Cable Name	Specification
①	I/O signal cable	Shielded cable
②	Safety signal cable	Shielded cable
③	Motor main circuit cable	Shielded cable
④	Encoder cable	Shielded cable
⑤	Main circuit cable	Shielded cable
⑥	Regenerative resistor unit cable	Non-shielded cable
⑦	Cooling fan cable	Shielded cable

■ Three-phase 400 V

- SGDV-□□□DE□A (□□□ = 1R9, 3R5, 5R4, 8R4, 120, 170) + SGDV-OSA01A

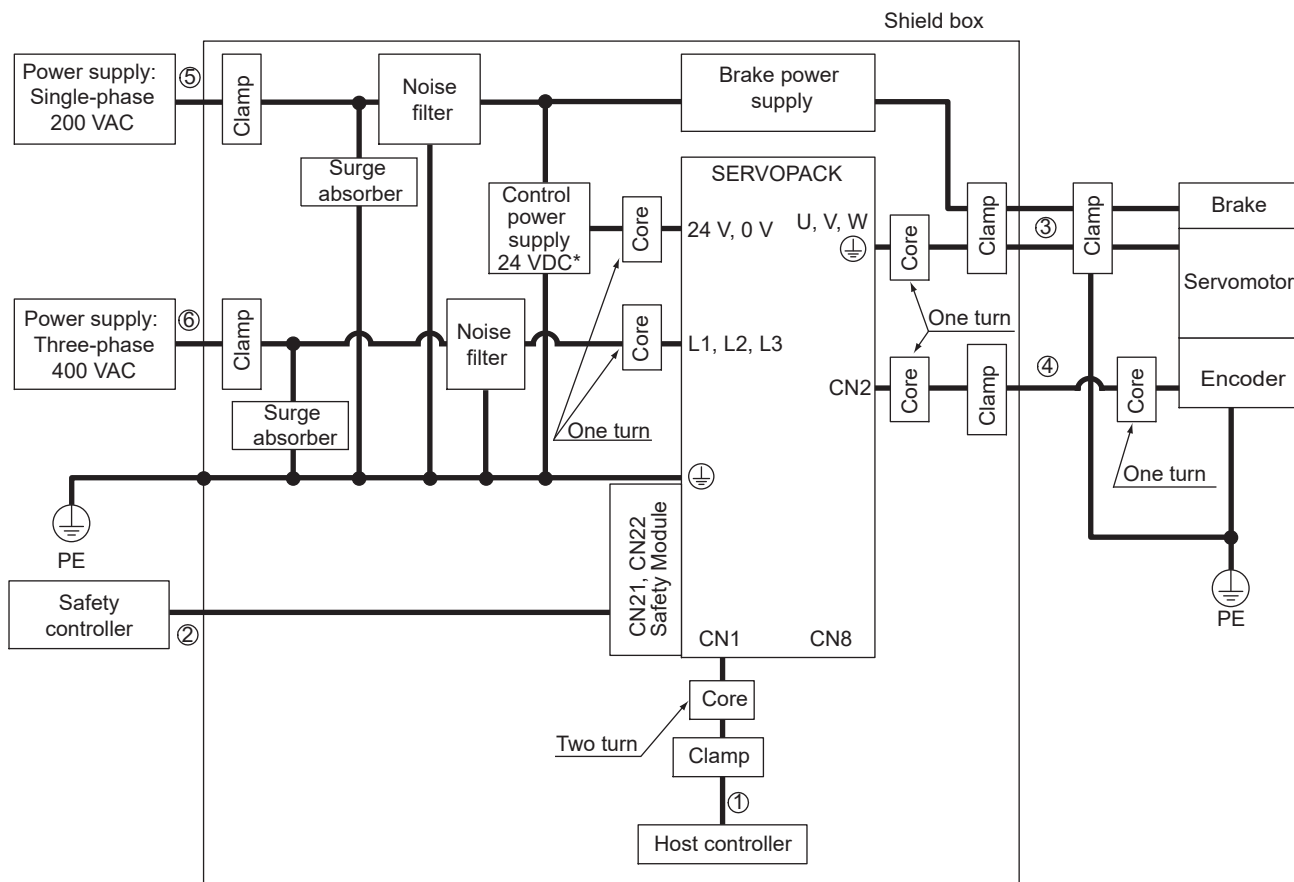

Symbol	Cable Name	Specification
①	I/O signal cable	Shielded cable
②	Safety signal cable	Shielded cable
③	Motor main circuit cable	Shielded cable
④	Encoder cable	Shielded cable
⑤	Control power cable	Shielded cable
⑥	Main circuit cable	Shielded cable

* Products that have received CE marking are recommended for the 24 VDC power supply.

■ Three-phase 400 V

- SGDV-□□□DE□A (□□□ = 210, 260, 280, 370) + SGDV-OSA01A

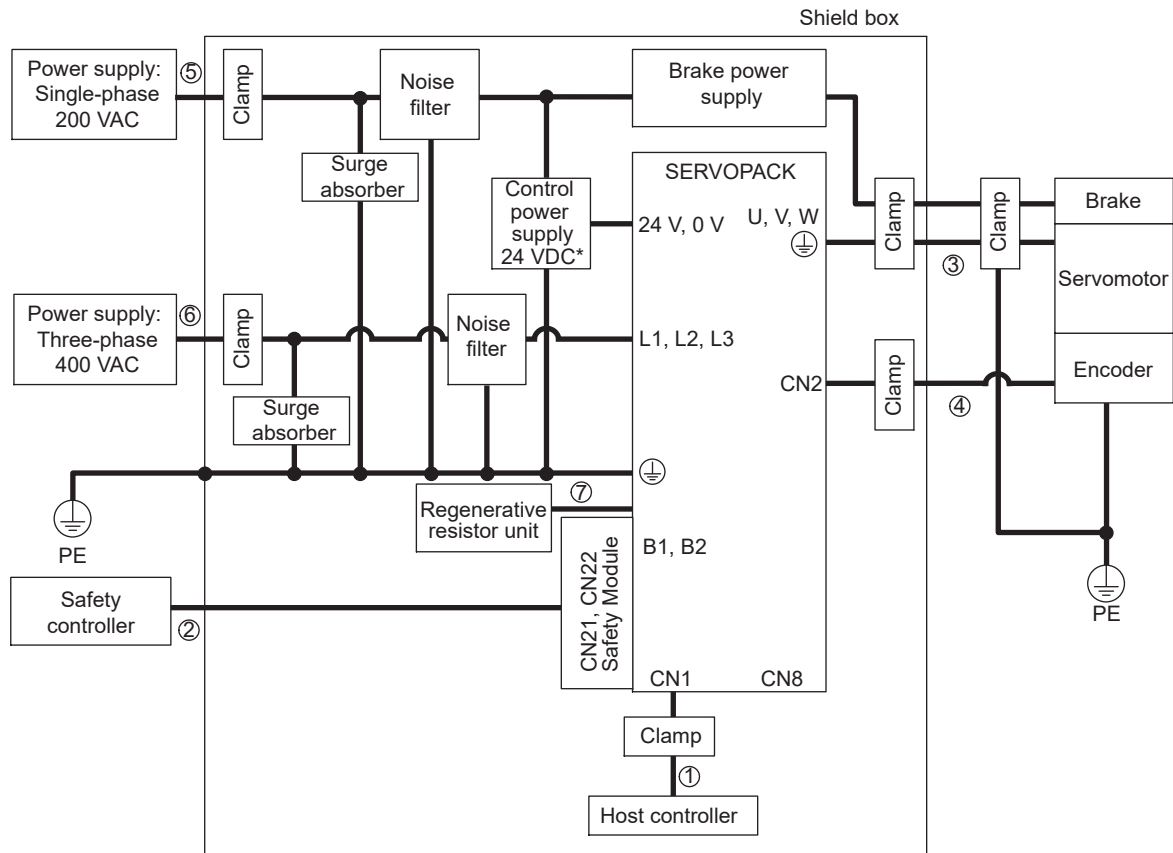

Symbol	Cable Name	Specification
①	I/O signal cable	Shielded cable
②	Safety signal cable	Shielded cable
③	Motor main circuit cable	Shielded cable
④	Encoder cable	Shielded cable
⑤	Control power cable	Shielded cable
⑥	Main circuit cable	Shielded cable
⑦	Regenerative resistor unit cable	Non-shielded cable

* Products that have received CE marking are recommended for the 24 VDC power supply.

3.3.2 Σ-V Series for Large-Capacity Models

(1) SGDV-□□□□□□□□ (Analog Voltage and Pulse Train Reference Models)

■ Three-phase 200 V

- SERVOPACK: SGDV-□□□□H0□□A (□□□ = 121, 161, 201) + SGDV-OSA01A
- Converter: SGDV-COA□□□AA (□□ = 2B, 3G)

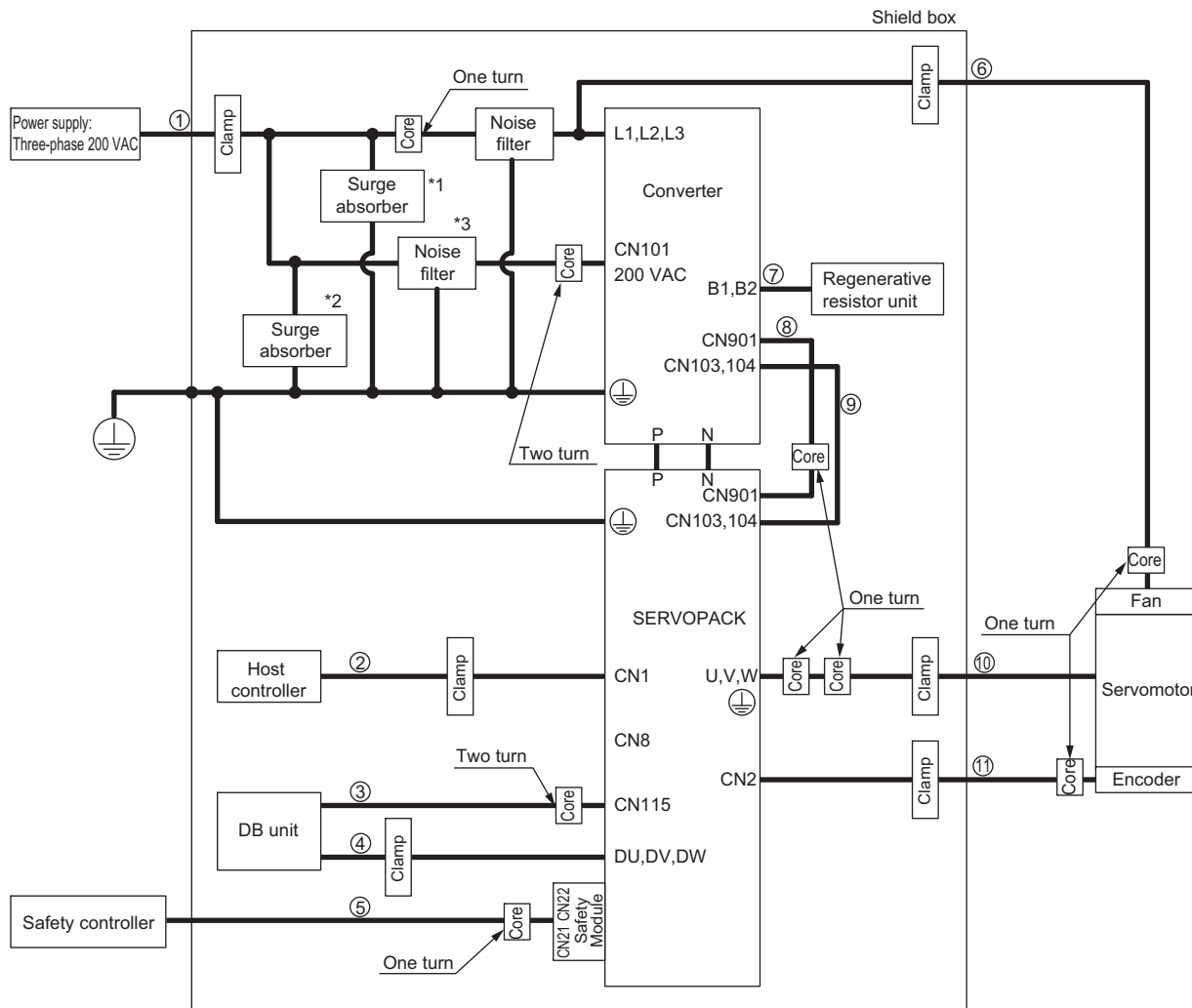

Symbol	Cable Name	Specification
①	Main circuit cable	Shielded cable
②	I/O signal cable	Shielded cable
③	DB unit signal cable	Non-shielded cable
④	DB unit power cable	Non-shielded cable
⑤	Safety signal cable	Shielded cable
⑥	Motor cooling fan cable	Shielded cable
⑦	Regenerative resistor unit cable	Non-shielded cable
⑧	I/O signal connection cable	Shielded cable
⑨	24-VDC control power cable	Non-shielded cable
⑩	Motor main circuit cable	Shielded cable
⑪	Encoder cable	Shielded cable

*1. Surge absorber: LT-C32G801WS (manufactured by Soshin Electric Co., Ltd.)
 *2. Surge absorber: LT-C12G801WS (manufactured by Soshin Electric Co., Ltd.)
 *3. Noise filter: HF2005A-UP (manufactured by Soshin Electric Co., Ltd.)

■ Three-phase 400 V

- SERVOPACK: SGDV-□□□J0□A (□□□ = 750, 101, 131) + SGDV-OSA01A
- Converter: SGDV-COA□□DA (□□ = 3Z, 5E)

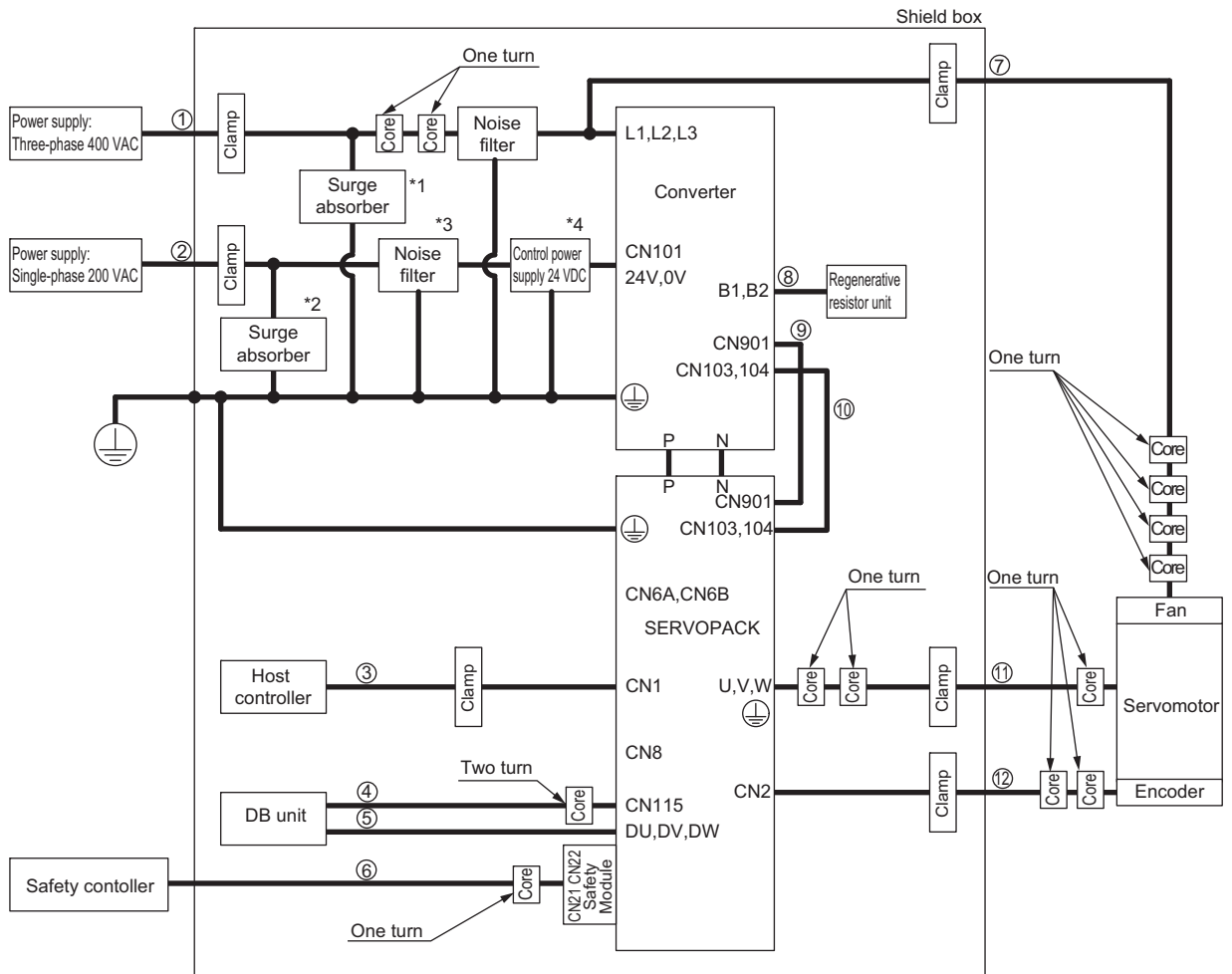

Symbol	Cable Name	Specification
①	Main circuit cable	Shielded cable
②	Control power cable	Shielded cable
③	I/O signal cable	Shielded cable
④	DB unit signal cable	Non-shielded cable
⑤	DB unit power cable	Non-shielded cable
⑥	Safety signal cable	Shielded cable
⑦	Motor cooling fan cable	Shielded cable
⑧	Regenerative resistor unit cable	Non-shielded cable
⑨	I/O signal connection cable	Shielded cable
⑩	24-VDC control power cable	Non-shielded cable
⑪	Motor main circuit cable	Shielded cable
⑫	Encoder cable	Shielded cable

- *1. Surge absorber: LT-C35G102WS (manufactured by Soshin Electric Co., Ltd.)
- *2. Surge absorber: LT-C12G801WS (manufactured by Soshin Electric Co., Ltd.)
- *3. Noise filter: HF2005A-UP (manufactured by Soshin Electric Co., Ltd.)
- *4. 24 VDC power supply: Power supply with double or reinforced insulation that has received CE marking.

(2) SGDV-□□□□1□□ (M-II Communications Reference Models)

■ Three-phase 200 V

- SERVOPACK: SGDV-□□□□H1□□ (□□□ = 121, 161, 201) + SGDV-OSA01A
- Converter: SGDV-COA□□□AA (□□ = 2B, 3G)

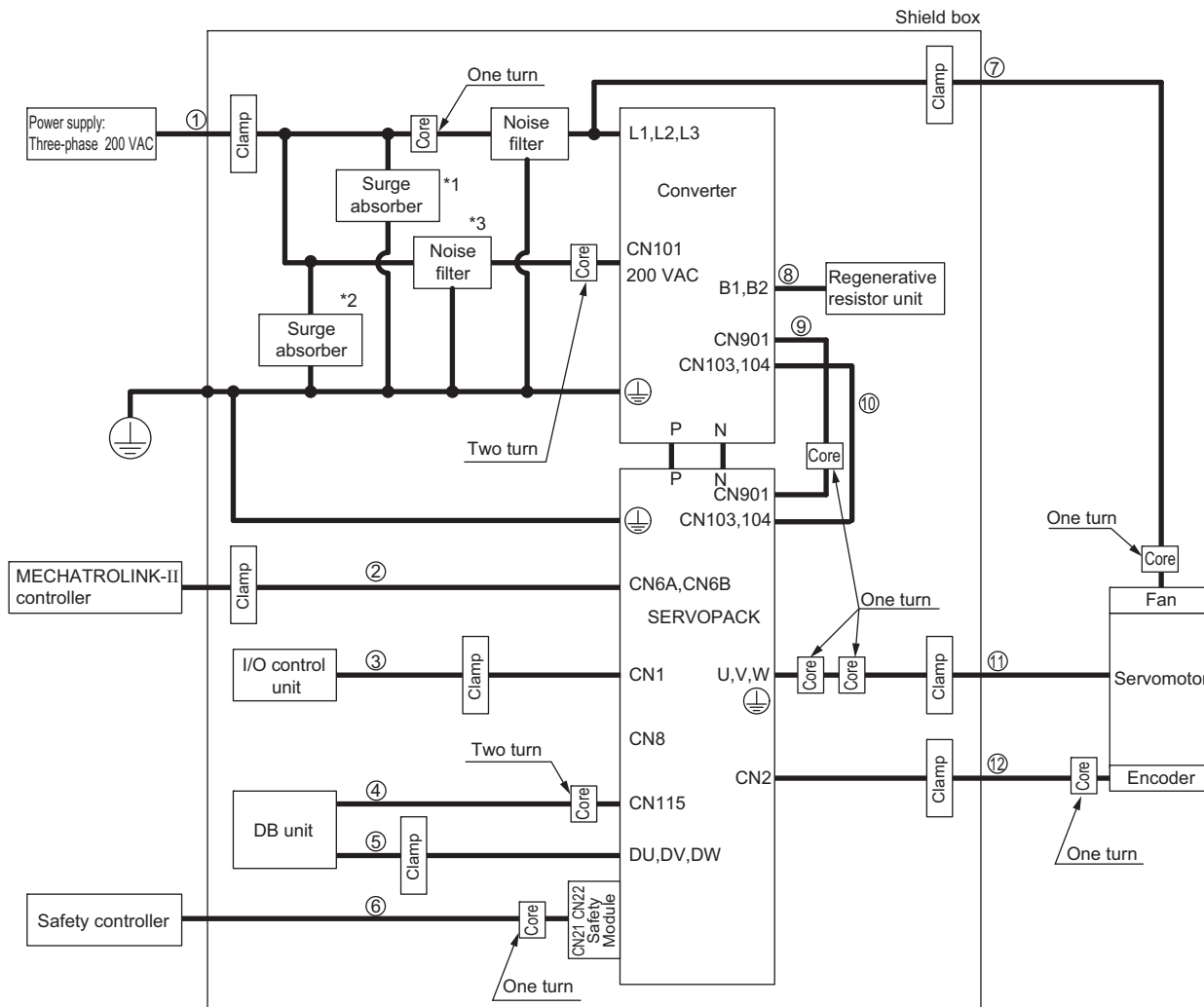

Symbol	Cable Name	Specification
①	Main circuit cable	Shielded cable
②	MECHATROLINK-II communication cable	Shielded cable
③	I/O signal cable	Shielded cable
④	DB unit signal cable	Non-shielded cable
⑤	DB unit power cable	Non-shielded cable
⑥	Safety signal cable	Shielded cable
⑦	Motor cooling fan cable	Shielded cable
⑧	Regenerative resistor unit cable	Non-shielded cable
⑨	I/O signal connection cable	Shielded cable
⑩	24-VDC control power cable	Non-shielded cable
⑪	Motor main circuit cable	Shielded cable
⑫	Encoder cable	Shielded cable

- *1. Surge absorber: LT-C32G801WS (manufactured by Soshin Electric Co., Ltd.)
- *2. Surge absorber: LT-C12G801WS (manufactured by Soshin Electric Co., Ltd.)
- *3. Noise filter: HF2005A-UP (manufactured by Soshin Electric Co., Ltd.)

■ Three-phase 400 V

- SERVOPACK: SGDV-□□□J1□A (□□□ = 750, 101, 131) + SGDV-OSA01A
- Converter: SGDV-COA□□DA (□□ = 3Z, 5E)

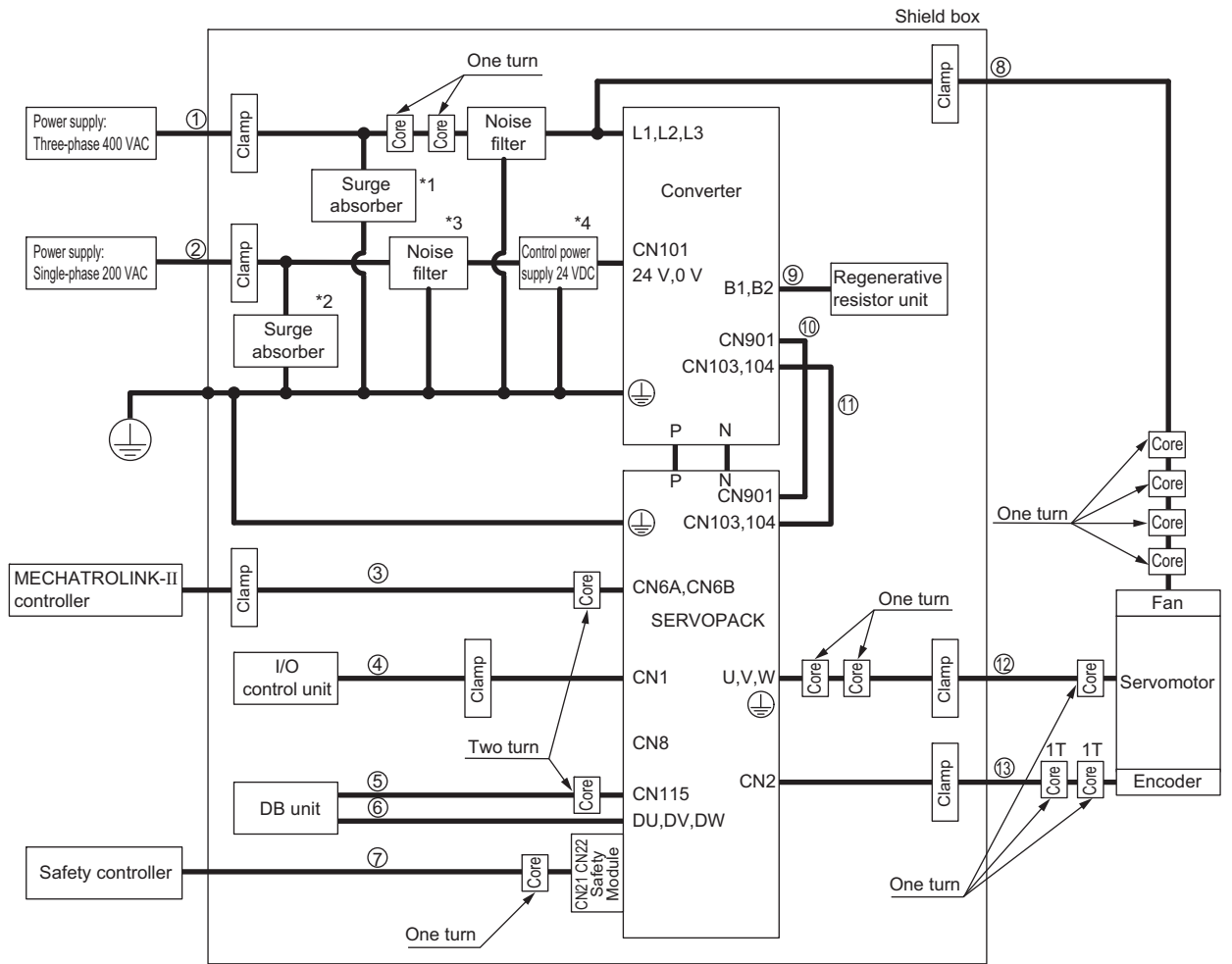

Symbol	Cable Name	Specification
①	Main circuit cable	Shielded cable
②	Control power cable	Shielded cable
③	MECHATROLINK-II communication cable	Shielded cable
④	I/O signal cable	Shielded cable
⑤	DB unit signal cable	Non-shielded cable
⑥	DB unit power cable	Non-shielded cable
⑦	Safety signal cable	Shielded cable
⑧	Motor cooling fan cable	Shielded cable
⑨	Regenerative resistor unit cable	Non-shielded cable
⑩	I/O signal connection cable	Shielded cable
⑪	24-VDC control power cable	Non-shielded cable
⑫	Motor main circuit cable	Shielded cable
⑬	Encoder cable	Shielded cable

- *1. Surge absorber: LT-C35G102WS (manufactured by Soshin Electric Co., Ltd.)
- *2. Surge absorber: LT-C12G801WS (manufactured by Soshin Electric Co., Ltd.)
- *3. Noise filter: HF2005A-UP (manufactured by Soshin Electric Co., Ltd.)
- *4. 24 VDC power supply: Power supply with double or reinforced insulation that has received CE marking.

(3) SGDV-□□□□2□□ (M-III Communications Reference Models)

■ Three-phase 200 V

- SERVOPACK: SGDV-□□□H2□□ (□□□ = 121, 161, 201) + SGDV-OSA01A
- Converter: SGDV-COA□□AA (□□ = 2B, 3G)

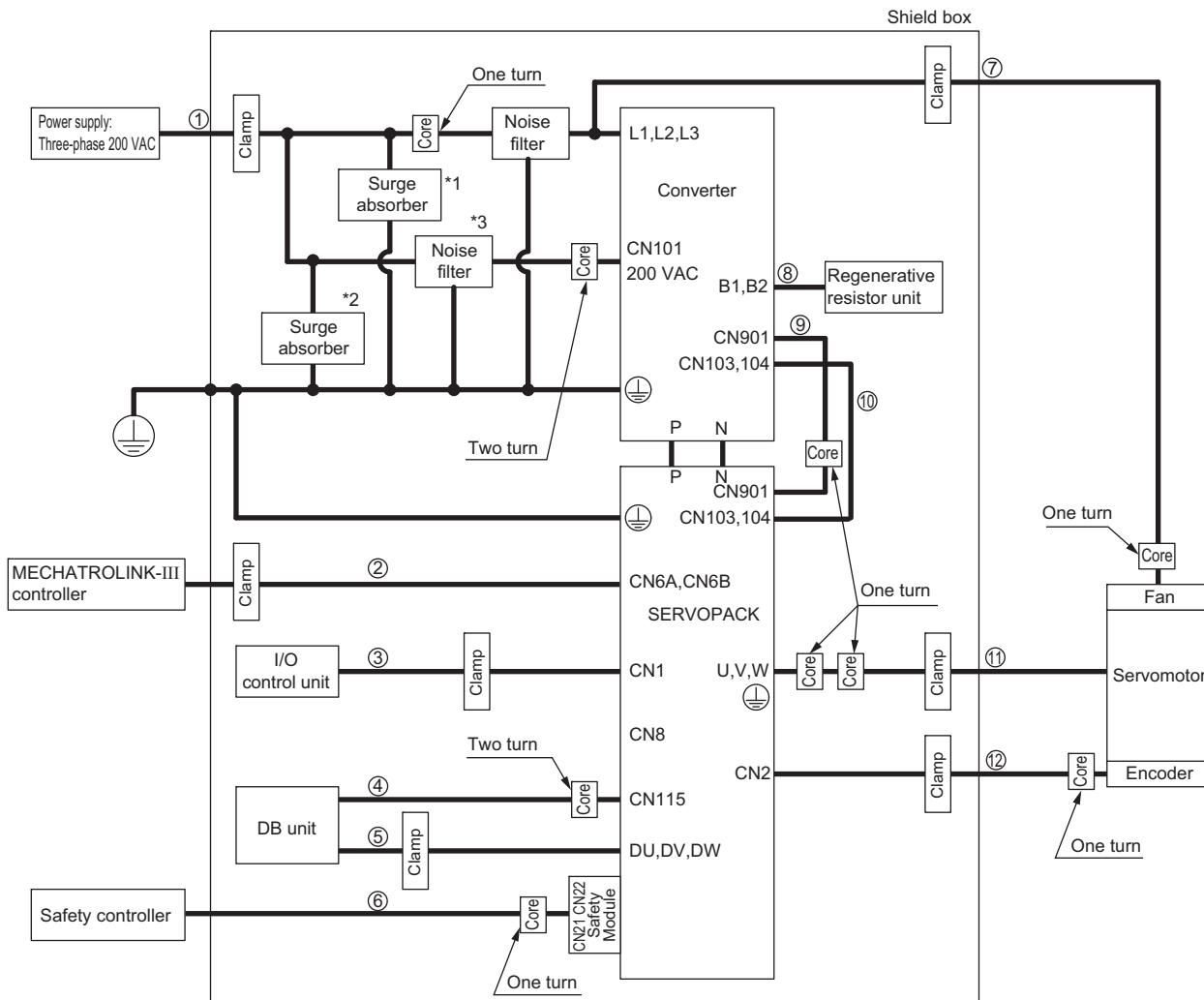

Symbol	Cable Name	Specification
①	Main circuit cable	Shielded cable
②	MECHATROLINK-III communication cable	Shielded cable
③	I/O signal cable	Shielded cable
④	DB unit signal cable	Non-shielded cable
⑤	DB unit power cable	Non-shielded cable
⑥	Safety signal cable	Shielded cable
⑦	Motor cooling fan cable	Shielded cable
⑧	Regenerative resistor unit cable	Non-shielded cable
⑨	I/O signal connection cable	Shielded cable
⑩	24-VDC control power cable	Non-shielded cable
⑪	Motor main circuit cable	Shielded cable
⑫	Encoder cable	Shielded cable

*1. Surge absorber: LT-C32G801WS (manufactured by Soshin Electric Co., Ltd.)
 *2. Surge absorber: LT-C12G801WS (manufactured by Soshin Electric Co., Ltd.)
 *3. Noise filter: HF2005A-UP (manufactured by Soshin Electric Co., Ltd.)

■ Three-phase 400 V

- SERVOPACK: SGDV-□□□J2□A (□□□ = 750, 101, 131) + SGDV-OSA01A
- Converter: SGDV-COA□□DA (□□ = 3Z, 5E)

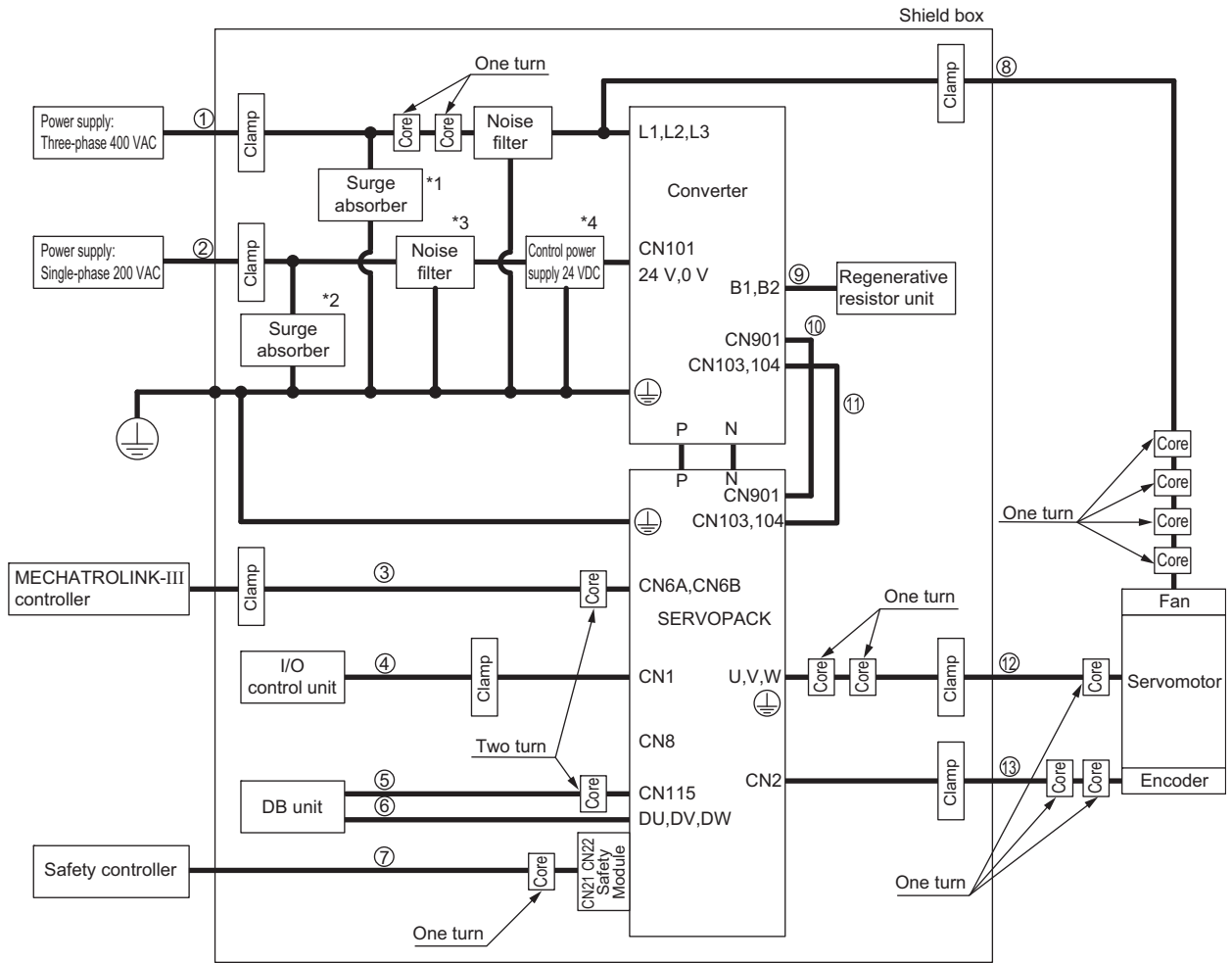

Symbol	Cable Name	Specification
①	Main circuit cable	Shielded cable
②	Control power cable	Shielded cable
③	MECHATROLINK-III communication cable	Shielded cable
④	I/O signal cable	Shielded cable
⑤	DB unit signal cable	Non-shielded cable
⑥	DB unit power cable	Non-shielded cable
⑦	Safety signal cable	Shielded cable
⑧	Motor cooling fan cable	Shielded cable
⑨	Regenerative resistor unit cable	Non-shielded cable
⑩	I/O signal connection cable	Shielded cable
⑪	24-VDC control power cable	Non-shielded cable
⑫	Motor main circuit cable	Shielded cable
⑬	Encoder cable	Shielded cable

*1. Surge absorber: LT-C35G102WS (manufactured by Soshin Electric Co., Ltd.)
 *2. Surge absorber: LT-C12G801WS (manufactured by Soshin Electric Co., Ltd.)
 *3. Noise filter: HF2005A-UP (manufactured by Soshin Electric Co., Ltd.)
 *4. 24 VDC power supply: Power supply with double or reinforced insulation that has received CE marking.

(4) SGDV-□□□□E□A (Command Option Attachable Type)

■ Three-phase 200 V

- SERVOPACK: SGDV-□□□HE□A (□□□ = 121, 161, 201) + SGDV-OSA01A
- Converter: SGDV-COA□□AA (□□ = 2B, 3G)

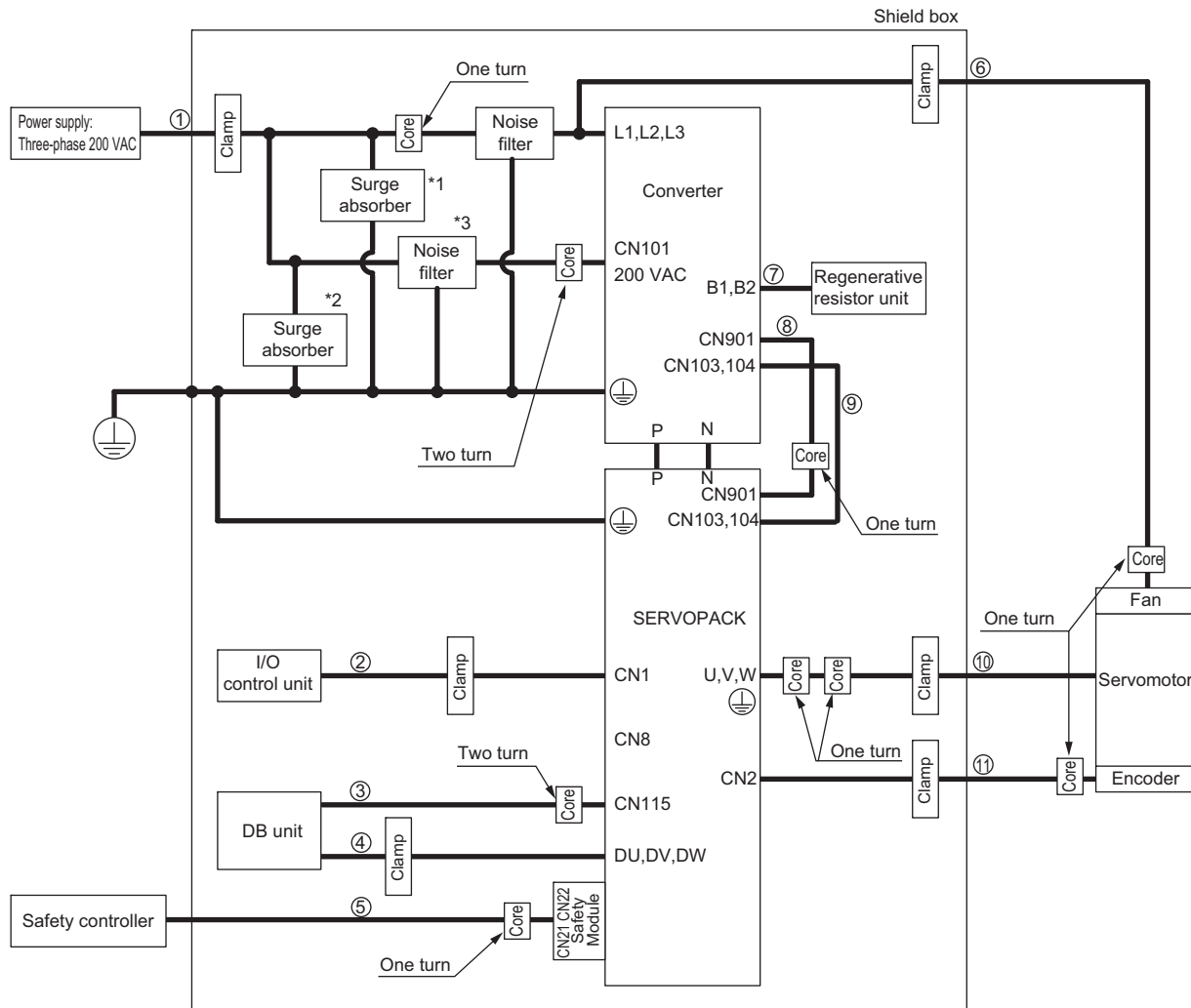

Symbol	Cable Name	Specification
①	Main circuit cable	Shielded cable
②	I/O signal cable	Shielded cable
③	DB unit signal cable	Non-shielded cable
④	DB unit power cable	Non-shielded cable
⑤	Safety signal cable	Shielded cable
⑥	Motor cooling fan cable	Shielded cable
⑦	Regenerative resistor unit cable	Non-shielded cable
⑧	I/O signal connection cable	Shielded cable
⑨	24-VDC control power cable	Non-shielded cable
⑩	Motor main circuit cable	Shielded cable
⑪	Encoder cable	Shielded cable

*1. Surge absorber: LT-C32G801WS (manufactured by Soshin Electric Co., Ltd.)
 *2. Surge absorber: LT-C12G801WS (manufactured by Soshin Electric Co., Ltd.)
 *3. Noise filter: HF2005A-UP (manufactured by Soshin Electric Co., Ltd.)

■ Three-phase 400 V

- SERVOPACK: SGDV-□□□JE□A (□□□ = 750, 101, 131) + SGDV-OSA01A
- Converter: SGDV-COA□□DA (□□ = 3Z, 5E)

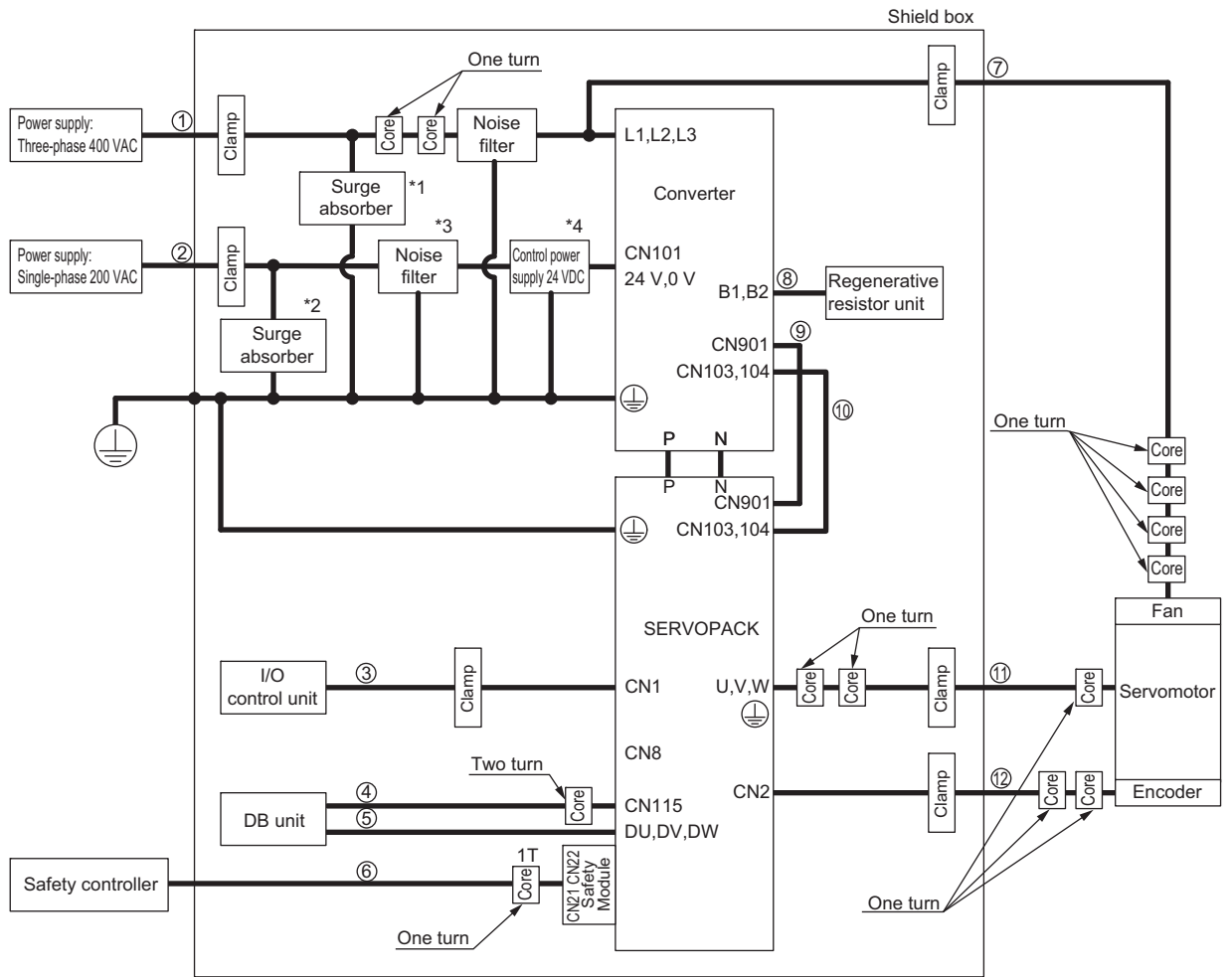

Symbol	Cable Name	Specification
①	Main circuit cable	Shielded cable
②	Control power cable	Shielded cable
③	I/O signal cable	Shielded cable
④	DB unit signal cable	Non-shielded cable
⑤	DB unit power cable	Non-shielded cable
⑥	Safety signal cable	Shielded cable
⑦	Motor cooling fan cable	Shielded cable
⑧	Regenerative resistor unit cable	Non-shielded cable
⑨	I/O signal connection cable	Shielded cable
⑩	24-VDC control power cable	Non-shielded cable
⑪	Motor main circuit cable	Shielded cable
⑫	Encoder cable	Shielded cable

- *1. Surge absorber: LT-C35G102WS (manufactured by Soshin Electric Co., Ltd.)
- *2. Surge absorber: LT-C12G801WS (manufactured by Soshin Electric Co., Ltd.)
- *3. Noise filter: HF2005A-UP (manufactured by Soshin Electric Co., Ltd.)
- *4. 24 VDC power supply: Power supply with double or reinforced insulation that has received CE marking.

3.3.3 Σ-7 Series

(1) SGD7S-□□□A0□□ (Analog Voltage and Pulse Train Reference Models)

■ Three-phase 200 V

- SGD7S-□□□A00A (□□□ = R70, R90, 1R6, 2R8, 3R8, 5R5, 7R6, 120, 180, 200, 330, 470, 550, 590, 780) + SGDV-OSA01A

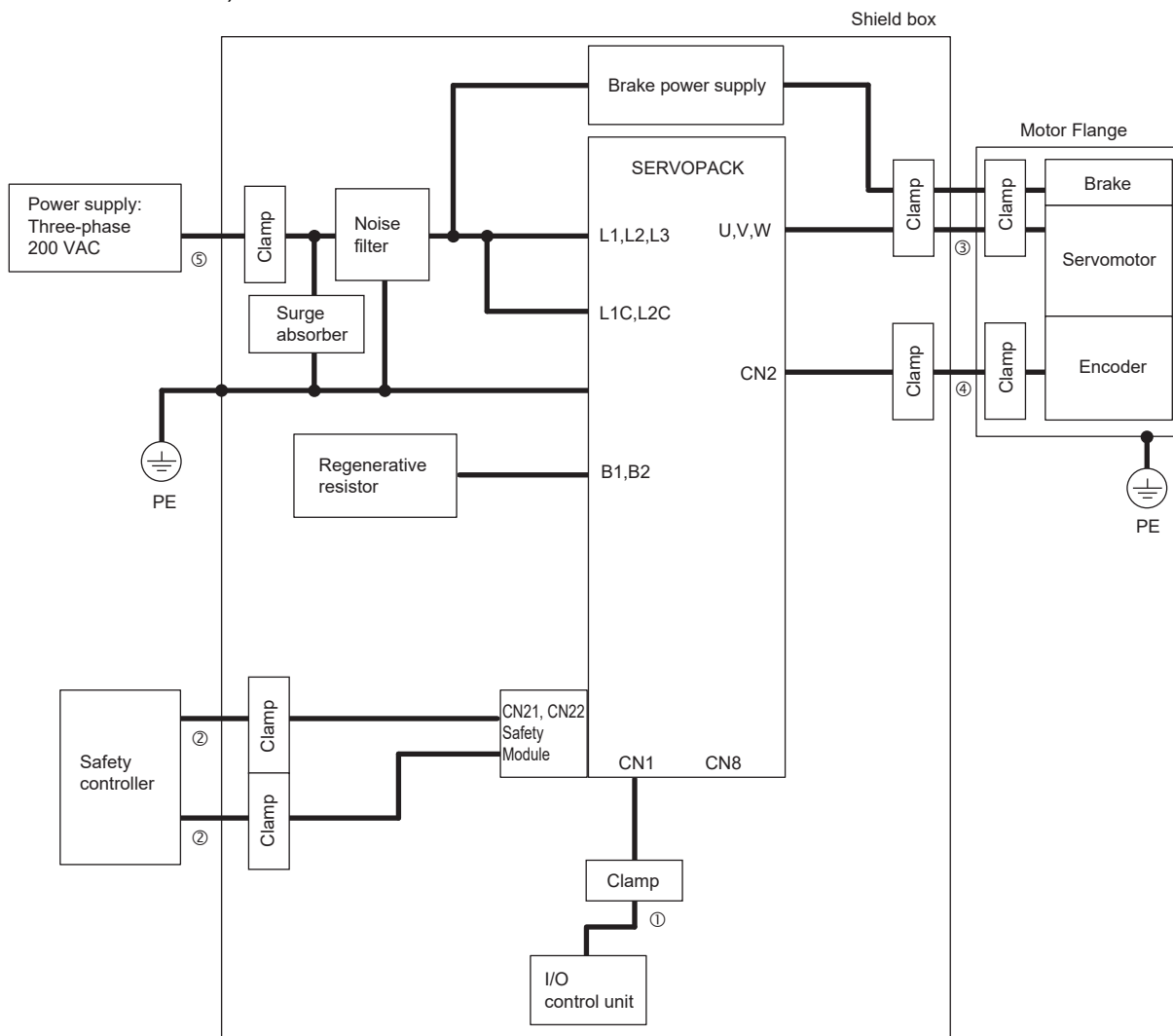

Symbol	Cable Name	Specification
①	I/O signal cable	Shielded cable
②	Safety signal cable	Shielded cable
③	Motor main circuit cable	Shielded cable
④	Encoder cable	Shielded cable
⑤	Main circuit cable	Shielded cable

(2) SGD7S-□□□A1□□ (M-II Communications Reference Models)

■ Three-phase 200 V

- SGD7S-□□□A10A (□□□ = R70, R90, 1R6, 2R8, 3R8, 5R5, 7R6, 120, 180, 200, 330, 470, 550, 590, 780) + SGD7-OSA01A

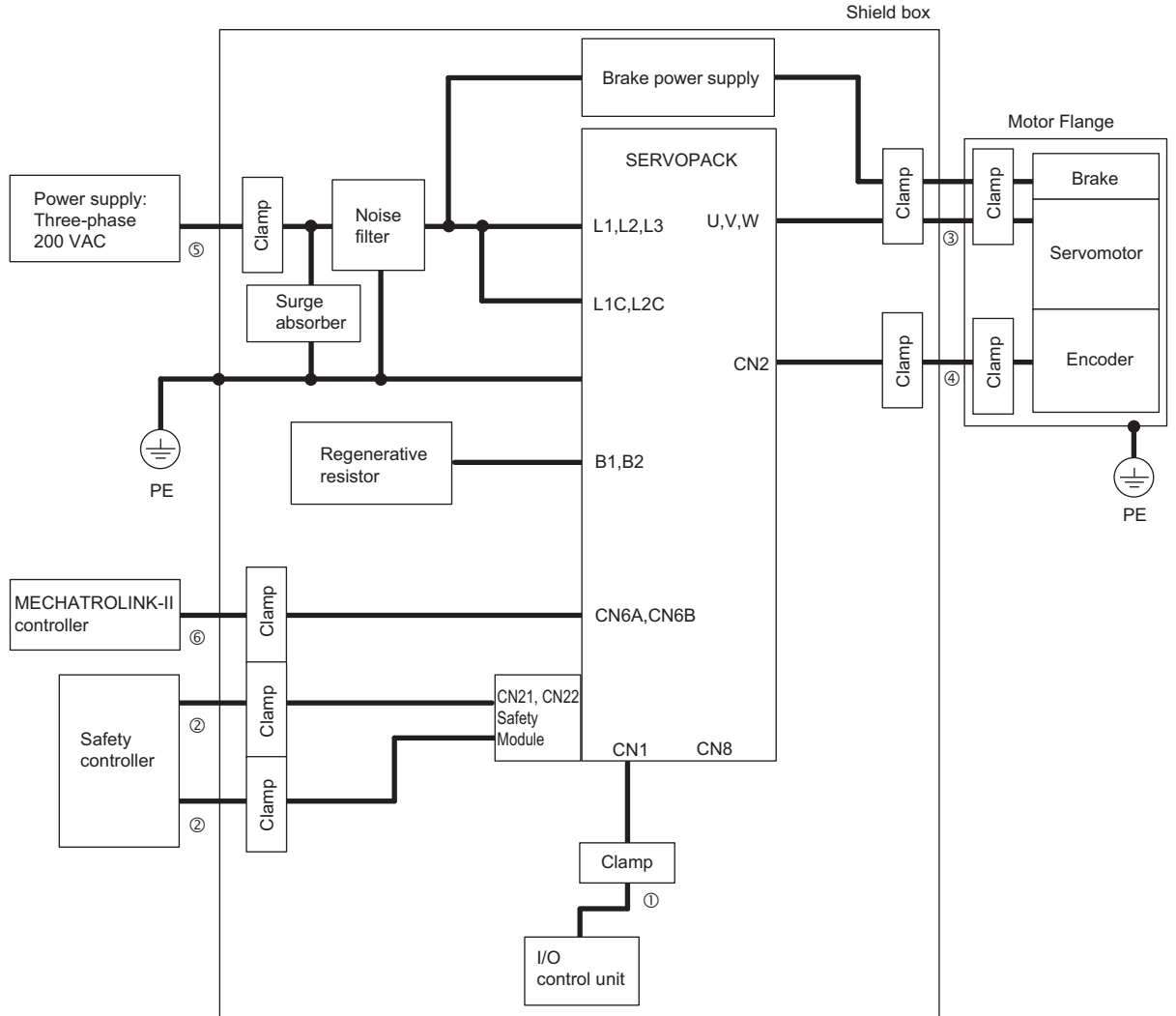

Symbol	Cable Name	Specification
①	I/O signal cable	Shielded cable
②	Safety signal cable	Shielded cable
③	Motor main circuit cable	Shielded cable
④	Encoder cable	Shielded cable
⑤	Main circuit cable	Shielded cable
⑥	Communications cable	Shielded cable

(3) SGD7S-□□□A2□□ (M-III Communications Reference Models)

■ Three-phase 200 V

- SGD7S-□□□A20A (□□□ = R70, R90, 1R6, 2R8, 3R8, 5R5, 7R6, 120, 180, 200, 330, 470, 550, 590, 780) + SGD7V-OSA01A

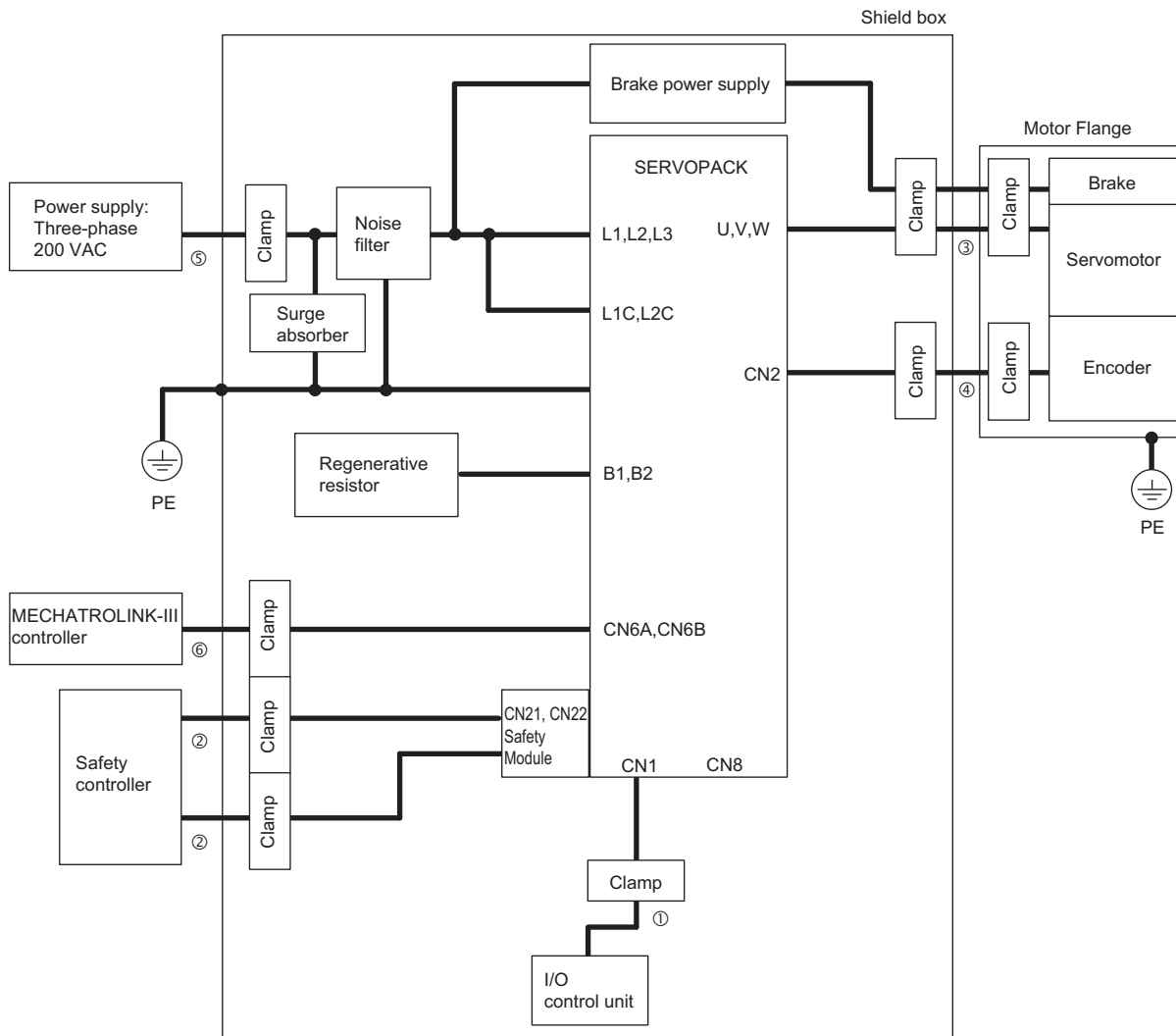

Symbol	Cable Name	Specification
①	I/O signal cable	Shielded cable
②	Safety signal cable	Shielded cable
③	Motor main circuit cable	Shielded cable
④	Encoder cable	Shielded cable
⑤	Main circuit cable	Shielded cable
⑥	Communications cable	Shielded cable

(4) SGD7S-□□□A4□□ (M-4 Communications Reference Models)

■ Three-phase 200 V

- SGD7S-□□□A40A (□□□ = R70, R90, 1R6, 2R8, 3R8, 5R5, 7R6, 120, 180, 200, 330, 470, 550, 590, 780) + SGD7-OSA01A

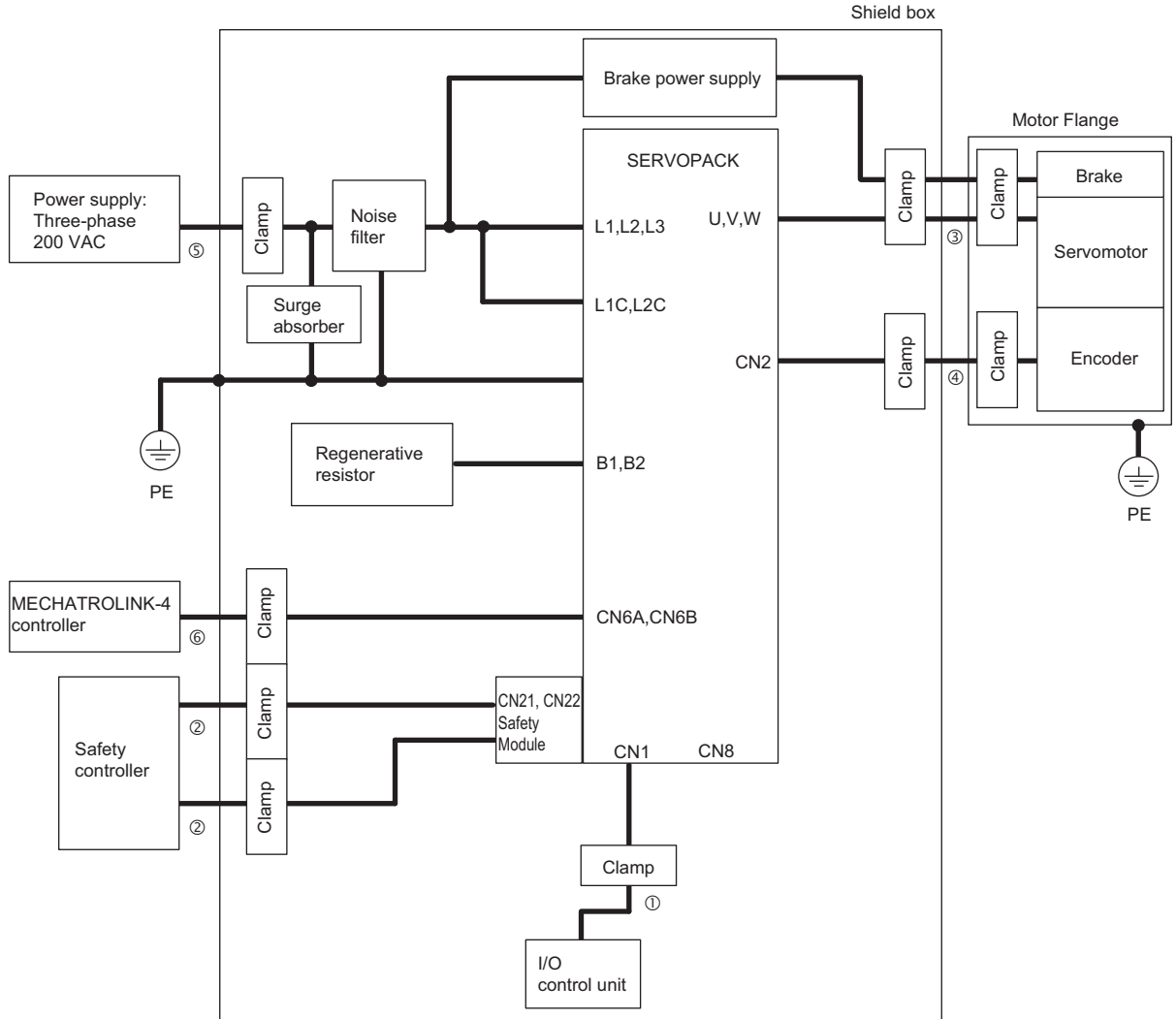

Symbol	Cable Name	Specification
①	I/O signal cable	Shielded cable
②	Safety signal cable	Shielded cable
③	Motor main circuit cable	Shielded cable
④	Encoder cable	Shielded cable
⑤	Main circuit cable	Shielded cable
⑥	Communications cable	Shielded cable

3.3.4 Other Precautions

(1) Attachment Methods of Ferrite Cores

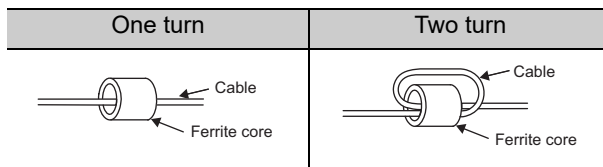

(2) Recommended Ferrite Core

■ Σ -V Series

Cable Name	Ferrite Core Model	Manufacturer
Motor main circuit cable	ESD-SR-250	NEC TOKIN Corp.

■ Large-Capacity Σ -V Series

• Three-phase 200 V

Cable Name	Ferrite Core Model	Manufacturer
Main circuit power supply cable	F11080GB	Hitachi Metals, Ltd.
Motor main circuit cable		
Control power cable	ESD-SR-250	NEC TOKIN Corp.
I/O signal connection cable		
Encoder cable		
DB unit signal cable		
Motor cooling fan cable		
Safety signal cable		

• Three-phase 400 V

Cable Name	Ferrite Core Model	Manufacturer
Main circuit power supply cable	RC5128ZZ	Soshin Electric Co., Ltd.
Motor main circuit cable (motor end)		
Motor main circuit cable (SERVOPACK end)	F11080GB	Hitachi Metals, Ltd.
Encoder cable	ESD-SR-250	NEC TOKIN Corp.
DB unit signal cable		
Motor cooling fan cable		
MECHATROLINK-II communication cable		
Safety signal cable		

(3) Recommended Noise Filter and Surge Absorber

For more information on recommended noise filters and surge absorbers, refer to Σ -V series, large capacity Σ -V series or Σ -7 series product catalog.

(4) Fixing the Cable

Fix and ground the cable shield using a piece of conductive metal.

- Example of Cable Clamp

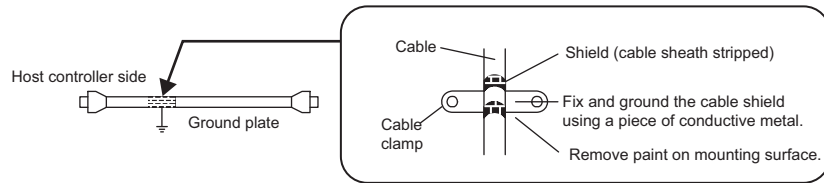

(5) Shield Box

A shield box, which is a closed metallic enclosure, is effective as reinforced shielding against electromagnetic interference (EMI) from SERVOPACKs. The structure of the box should allow the main body, door, and cooling unit to be attached to the ground. The box opening should be as small as possible.

<Note>

Do not connect the digital operator and the analog monitor cable to the SERVOPACK during operations. Connect them only when the machinery is stopped during maintenance.

Wiring and Connection

This chapter describes an example of how a system is configured using the Safety Module and how the I/O signals are connected.

For details on the main circuit, encoders, and regenerative resistors, refer to the manual for SERVOPACK being used.

For more information on safe and stable usage of the servo system, be sure to read the precautions in the sections labelled, “**!** IMPORTANT,” in the manuals.

4.1 System Configuration Diagram	4-2
4.1.1 Σ -V Series System Configuration Diagram	4-2
4.1.2 Σ -7 Series System Configuration Diagram	4-3
4.2 I/O Signal Connections	4-4
4.2.1 Terminal Layout	4-4
4.2.2 Electrical Specifications and Connections of Input Circuit	4-5
4.2.3 Electrical Specifications and Connections of Output Circuit	4-6

4.1 System Configuration Diagram

An example of system configuration using SERVOPACK for MECHATROLINK-II communications reference is shown below.

4.1.1 Σ -V Series System Configuration Diagram

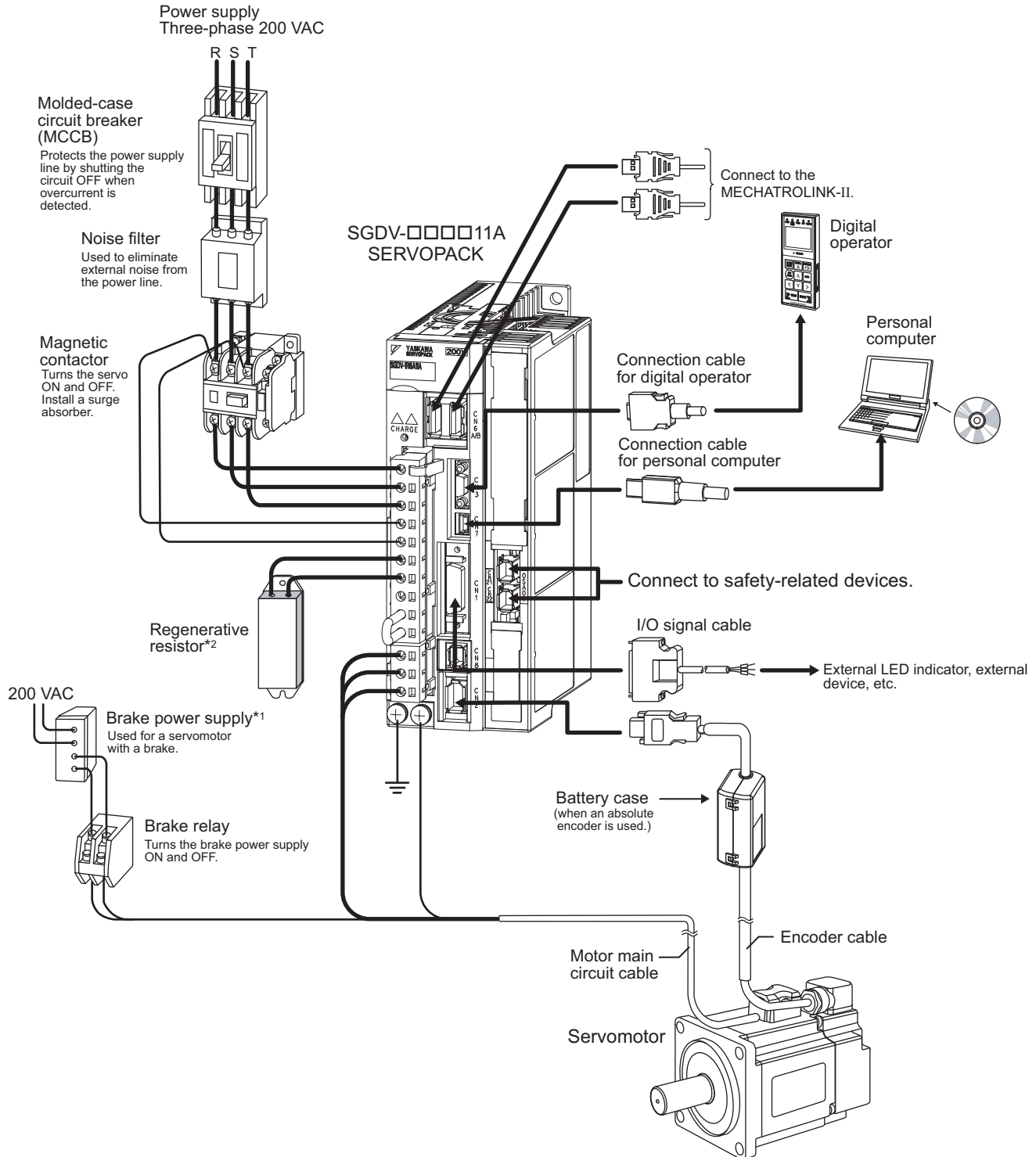

*1. Use a 24-VDC power supply. (Not included.)

If using a 90-VDC power supply for a brake, however, use one of the following power supplies.

- For 200-V input voltage: LPSE-2H01-E
- For 100-V input voltage: LPDE-1H01-E

For details, refer to *Σ -V Series Product Catalog* (No.: KAEP S800000 42).

*2. Before connecting an external regenerative resistor to the SERVOPACK, refer to the manual for your SERVOPACK.
Note: The connections and wiring of the power supply of the main circuit and that of the controls differ in accordance with the SERVOPACK to be used. For details, refer to the manual for your SERVOPACK.

4.1.2 Σ -7 Series System Configuration Diagram

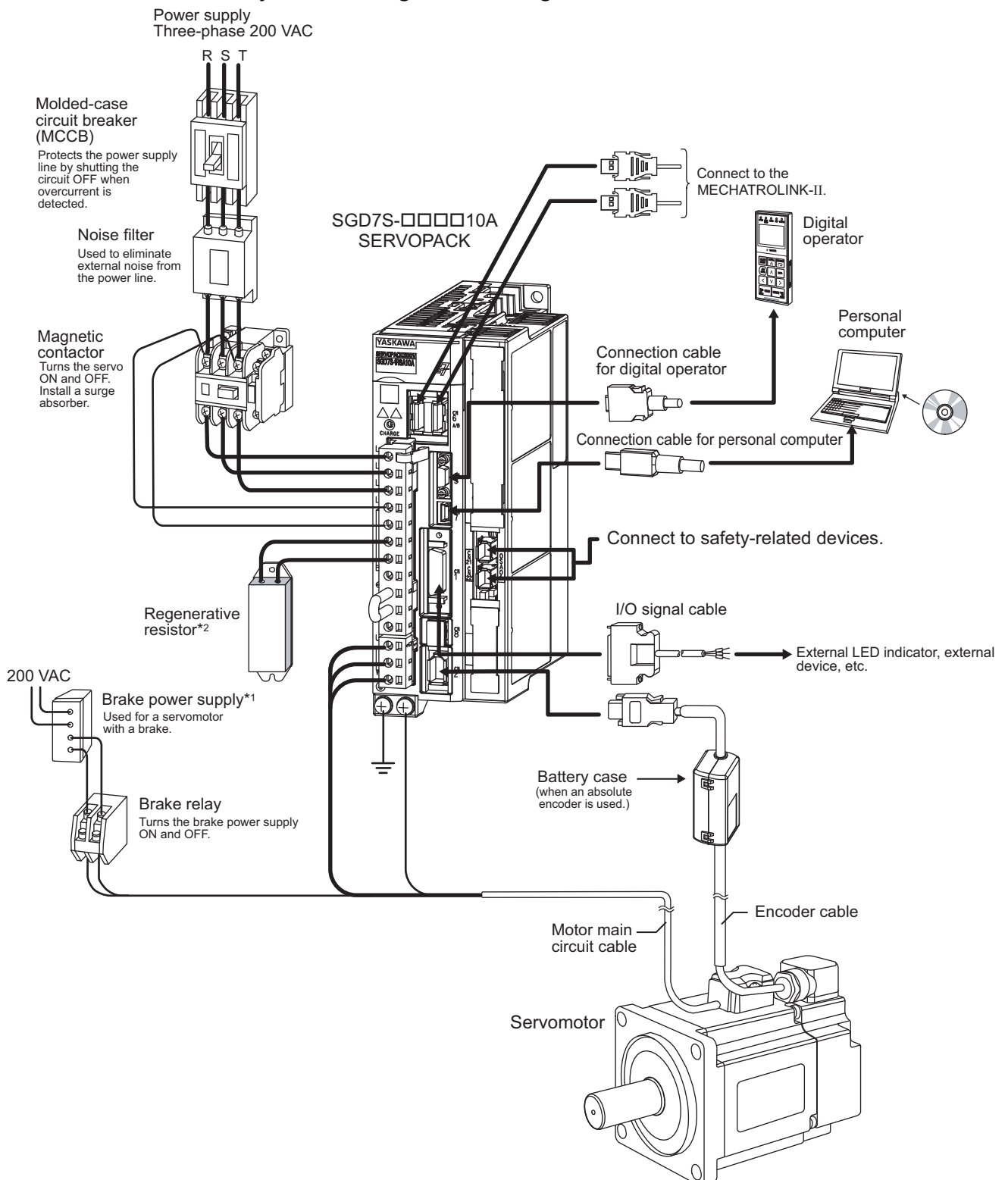

*1. Use a 24-VDC power supply. (Not included.)

If using a 90-VDC power supply for a brake, however, use one of the following power supplies.

- For 200-V input voltage: LPSE-2H01-E
- For 100-V input voltage: LPDE-1H01-E

For details, refer to *Σ -V Series Product Catalog* (No.: KAEP S800000 42).

*2. Before connecting an external regenerative resistor to the SERVOPACK, refer to the manual for your SERVOPACK.

Note: The connections and wiring of the power supply of the main circuit and that of the controls differ in accordance with the SERVOPACK to be used. For details, refer to the manual for your SERVOPACK.

4.2 I/O Signal Connections

This section describes the names and functions of I/O connectors (CN21 and CN22) for the Safety Functions A and B.

4.2.1 Terminal Layout

(1) I/O Connector for Safety Function A (CN21)

Signal	Pin No.	Name	Function	Reference Section
–	1	–	–	–
–	2	–	–	–
/SRI-A1-	3	Safety Request Input Signal A1	Input signal for Safety Function A	6.2.2
/SRI-A1+	4			
/SRI-A2-	5	Safety Request Input Signal A2		
/SRI-A2+	6			
EDM-A-	7	External Device Monitor Output Signal A	Output signal indicates that Safety Function A activates without failure.	6.2.3
EDM-A+	8			

(2) I/O Connector for Safety Function B (CN22)

Signal	Pin No.	Name	Function	Reference Section
–	1	–	–	–
–	2	–	–	–
/SRI-B1-	3	Safety Request Input Signal B1	Input signal for Safety Function B	6.2.2
/SRI-B1+	4			
/SRI-B2-	5	Safety Request Input Signal B2		
/SRI-B2+	6			
EDM-B-	7	External Device Monitor Output Signal B	Output signal indicates that Safety Function B activates without failure.	6.2.3
EDM-B+	8			

4.2.2 Electrical Specifications and Connections of Input Circuit

This section describes the characteristics of the input signals assigned to the CN21 and CN22 connectors on the Safety Module.

(1) Specifications

Name	Signal	Pin No.	Input Status	Meaning
Safety Request Input Signal A	SRI-A1	CN21-4 CN21-3	ON	The SERVOPACK is operating normally.
			OFF	Safety Function A activates.
	SRI-A2	CN21-6 CN21-5	ON	The SERVOPACK is operating normally.
			OFF	Safety Function A activates.
Safety Request Input Signal B	SRI-B1	CN22-4 CN22-3	ON	The SERVOPACK is operating normally.
			OFF	Safety Function B activates.
	SRI-B2	CN22-6 CN22-5	ON	The SERVOPACK is operating normally.
			OFF	Safety Function B activates.

Electrical characteristics of Safety Request Input Signal are as follows.

Items	Characteristics	Remarks
Input Current	5 mA (Typ.)	This is the value per channel.
ON Input Voltage Range	+20 V to +26 V	–
OFF Input Voltage Range	0 V to +2 V	–
Maximum Pulse Width	20 ms	The Safety Request Input Signal will not detect pulses with pulse widths of 0.5 ms or shorter.

(2) Connection Example

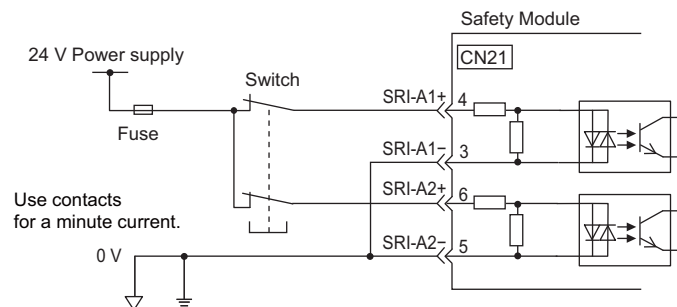

Note: This is the same for Safety Request Input Signal B.

4.2.3 Electrical Specifications and Connections of Output Circuit

This section describes the characteristics of the output signals assigned to the CN21 and CN22 connectors on the Safety Module.

(1) Specifications

Name	Signal	Pin No.	Input Status	Meaning
External Device Monitor Output Signal A	EDM-A	CN21-8 CN21-7	ON	Safety Function A activates without fault.
			OFF	The SERVOPACK is operating normally, or Safety Function A is fault.
External Device Monitor Output Signal B	EDM-B	CN22-8 CN22-7	ON	Safety Function B activates without fault.
			OFF	The SERVOPACK is operating normally, or Safety Function B is fault.

Electrical characteristics of External Device Monitor Output Signal are as follows.

Items	Characteristics	Remarks
Maximum Allowable Voltage	30 VDC	–
Maximum Current	50 mADC	–
Maximum Voltage Drop at ON	1.5 V	<ul style="list-style-type: none"> Voltage between EDM-A+ to EDM-A– at current 50 mA. Voltage between EDM-B+ to EDM-B– at current 50 mA.
Operating Current at ON	5 mA to 50 mA	–

(2) Connection Example

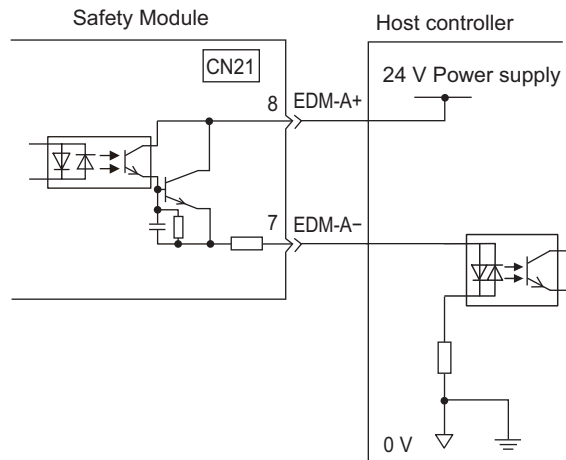

Note: This is the same for External Device Monitor Output Signal B.

Precautions and Basic Settings Required before Starting Operation

This chapter describes information that is required before starting operation. Be sure to read the following safety precautions, risk assessment information, limitations, and basic settings before starting operation, and use the Safety Module after properly understanding all of this information.

5.1 Safety Precautions for Using the Safety Module	5-2
5.2 Risk Assessment	5-3
5.3 Limitations	5-4
5.3.1 Limitations on Lower Limit of Encoder Output Pulses	5-4
5.3.2 Limitations on the Use of the Test without Motor Function	5-7
5.3.3 Limitations on the Use of an External Encoder	5-7
5.3.4 Device Combination	5-7
5.4 Basic Settings Required before Starting Operation	5-8
5.5 Checking the Operation	5-9

5.1 Safety Precautions for Using the Safety Module

Carefully read the following important precautions and observe them when using the Safety Module.

WARNING



- Installation, disassembly, or repair must be performed only by authorized personnel.
Failure to observe this precaution may result in electric shock or injury.
- Engineers designing a mechanical system using the safety functions of the Safety Module must have complete knowledge of the relative safety standards and a full understanding of the safety functions of the Safety Module.
Improper use may result in injury or damage to the product.
- When creating a safety design for a mechanical system using the safety functions of the Safety Module, always perform risk assessment of the system to identify residual risks.
Improper use may result in injury or damage to the product.
- The dynamic brake is not a safety-related part of a control system. Create the safety design of the mechanical system in such a way that any trouble in the dynamic brake function does not create a hazard when the safety functions of the Safety Module operate.
Improper use may result in injury or damage to the product.
- Connect device conforming to the relative safety standards to the connector for Safety Request Input Signals.
Improper use may result in injury or damage to the product.
- The safety functions of the Safety Module are not for emergency stopping. To use the safety functions for emergency stopping, separately shut OFF the power supply from the electromechanical section to the motor.
Improper use may result in injury or damage to the product.
- The safety functions of the Safety Module are not for shutting OFF the power supply to the SERVOPACK and do not provide electrical isolation. Be sure to separately shut OFF the power supply to the SERVOPACK when performing maintenance or inspection of the SERVOPACK.
Failure to observe this warning may result in electric shock.
- Be sure to check the safety-related parameters before using the safety functions of the Safety Module.
Improper use may result in injury or damage to the product.
- If the Safety Module or SERVOPACK is changed when starting the servo system or during maintenance or inspection, be sure to check the operation of the safety functions in the actual application after performing wiring.
Improper use may result in injury or damage to the product.
- Make sure that the safety function jumper connector is not connected to the connector (CN8) of the SERVOPACK.
If the safety jumper connector is connected, the safety functions may not operate properly, which may result in injury or damage to the product.

5.2 Risk Assessment

When using the Safety Module, be sure to perform risk assessment of the servo system in advance. Make sure that the safety level of the standards is met. For details about the standards, refer to *Compliance with UL Standards, EU Directives, UK Regulations, and Other Safety Standards* at the front of this manual.

The following residual risks can be present even when the safety functions operate. Therefore, safety must always be given consideration during risk assessment.

- If external forces (such as gravitational force with a vertical axis) are applied when the safety functions of the Safety Module are operating, the motor will rotate due to the action of these external forces. Provide a separate mechanical brake to secure the motor.
- If the SERVOPACK fails, the motor may operate within a range of 180 electrical degrees. Make sure that safety is ensured even in hazardous situations.

The number of rotations and movement distance for each type of motor are listed below.

Rotational Servomotor: 1/6 rotation max. (rotation angle at motor shaft conversion)

Direct Drive Motor: 1/20 rotation max. (rotation angle at motor shaft conversion)

Linear Servomotor: 30 mm max.

5.3 Limitations

When the Safety Module is used, use of Pn212 or Pn281 to control the encoder’s output pulses, test without the motor function, and the external encoder of the SERVOPACK will be restricted.

5.3.1 Limitations on Lower Limit of Encoder Output Pulses

When the Safety Module is used, the lower limit for the encoder’s output pulses is restricted. Set the encoder’s output pulses to a value that is higher than the lower limit. If the pulses number is lower than the lower limit, the following alarm will occur.

Alarm Number	Name	Meaning	Alarm Reset	Stopping Method
A.EB2	Safety Module: Parameter Setting Error	The settings of safety-related module parameters or safety-related servo parameter.	Not possible	According to the setting of Pn001.0

The following section shows the method used to calculate the lower limit for the encoder’s output pulses.

■ Rotational Servomotors

Pn212: Encoder Output Pulses [pulses/rev]

$$\text{Lower limit of Pn212 [pulses/rev]} = 75000 / \text{Motor Max. Speed [min}^{-1}\text{]}$$

Lower Limit of Encoder Output Pulse

Motor Max. Speed [min ⁻¹]	Lower Limit [pulses/rev] of Encoder Output Pulses (Pn212)
6000	16
5000	16
3000	25
1500	50
750	100
375	200

Example of Detection Accuracy at Different Motor Speeds

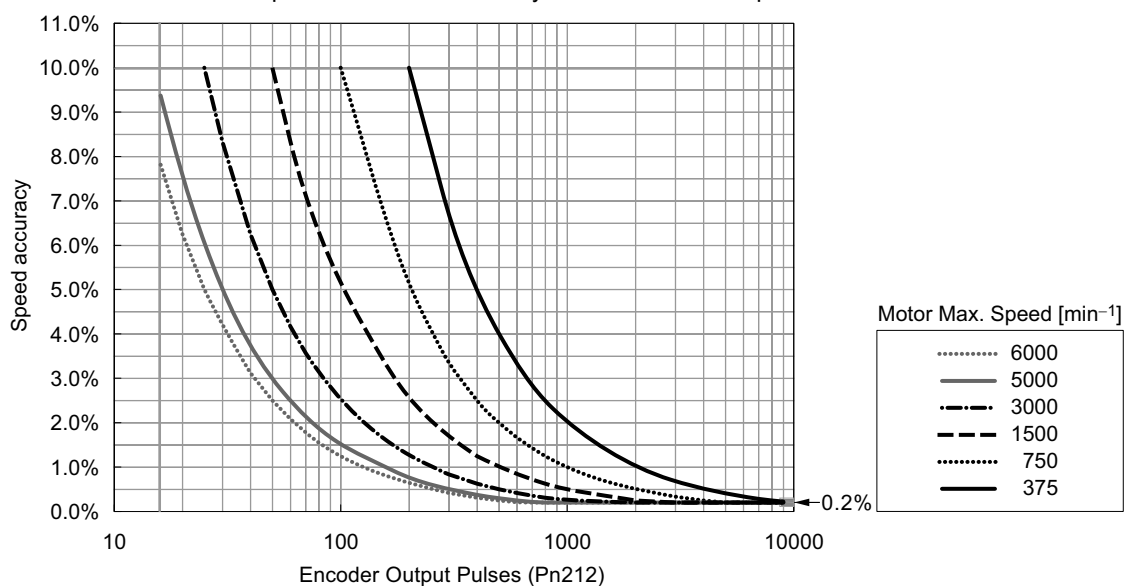

Note: The Motor Max. Speed (Pc62) of the Safety-related Servo Parameter depends on the connected rotational servomotor.

- **Monitoring Speed Margin**

The monitoring speed margin is added to the monitoring speed of the safety function according to the detection accuracy of motor speed.

The Safety Module performs speed monitoring using a monitoring speed to which this monitoring speed margin was added.

The monitoring speed margin is calculated using the following formula.

Monitoring speed margin: S_{mgn} [min^{-1}]

$$S_{\text{mgn}} = \text{Motor maximum speed} [\text{min}^{-1}] \times \text{Detection accuracy of motor speed} [\%]$$

For the detection accuracy of motor speed, take the value from the Example of Detection Accuracy at Different Motor Speeds found in *5.3.1 Limitations on Lower Limit of Encoder Output Pulses*.

The lower limit value of the monitoring speed margin is 4 [min^{-1}].

Calculation Example 1:

When using a Servomotor with a maximum speed of 6000 [min^{-1}] and Pn212 (Encoder Output Pulses) is set to 16384

$$\begin{aligned} S_{\text{mgn}} &= 6000[\text{min}^{-1}] \times 0.2[\%] \\ &= 12[\text{min}^{-1}] \end{aligned}$$

Calculation Example 2:

When using a Servomotor with a maximum speed of 750 [min^{-1}] and Pn212 (Encoder Output Pulses) is set to 16384

$$\begin{aligned} S_{\text{mgn}} &= 750[\text{min}^{-1}] \times 0.2[\%] \\ &= 1.5[\text{min}^{-1}] \end{aligned}$$

In this case, S_{mgn} is 4 [min^{-1}] because calculation result is less than the lower limit value.

Calculation Example 3:

When using a Servomotor with a maximum speed of 3000 [min^{-1}] and Pn212 (Encoder Output Pulses) is set to 100

$$\begin{aligned} S_{\text{mgn}} &= 3000[\text{min}^{-1}] \times 2.5[\%] \\ &= 75[\text{min}^{-1}] \end{aligned}$$

5.3.1 Limitations on Lower Limit of Encoder Output Pulses

■ Linear Servomotors

Pn281: Encoder Output Resolution [edge/pitch]

$$\text{Lower limit of Pn281 [edge/pitch]} \geq \frac{5 \times \text{Pn282 (Linear Scale Pitch) } [\mu\text{m/pitch}]}{\text{Pn385 (Motor Max. Speed) [mm/s]}}$$

Lower Limit of Encoder Output Resolution

Motor Max. Speed [mm/s]	Linear Scale Pitch [$\mu\text{m/pitch}$]	Lower Limit of Encoder Output Resolution (Pn281) [edge/pitch]
5000	4	1
	20	
	256	
4000	4	1
	20	
	256	
3000	20	1
	256	
1500	20	1
	256	
1000	20	1
	256	2
100	0.4	1
	4	
	20	
	256	13

Example of Detection Accuracy at Different Motor Speeds

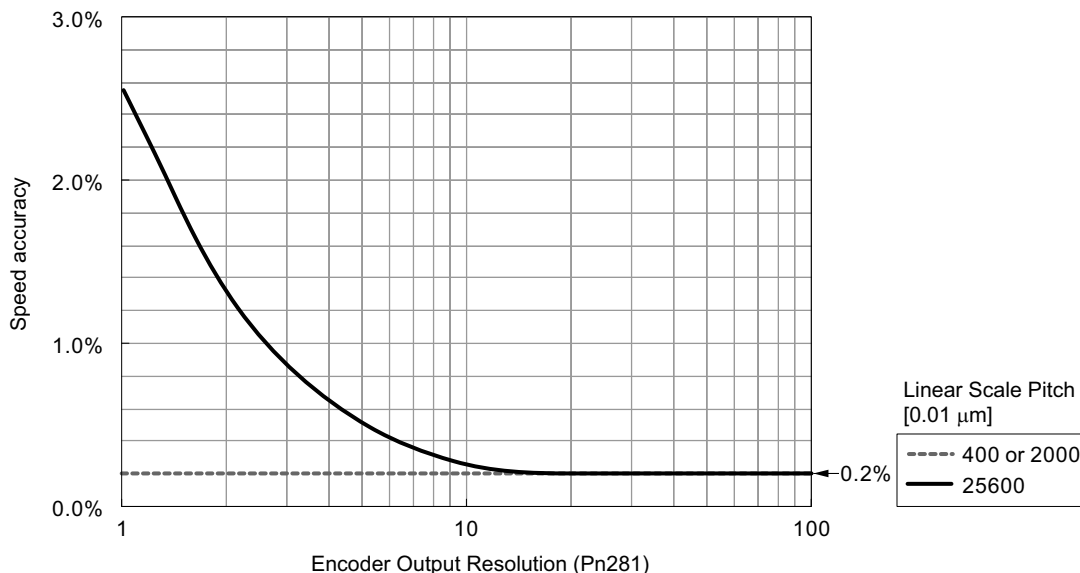

Note: The Motor Max. Speed (Pc62) of the Safety-related servo parameter is 5000 mm/s in this example.

• Monitoring Speed Margin

The monitoring speed margin is added to the monitoring speed of the safety function according to the detection accuracy of motor speed.

The Safety Module performs speed monitoring using a monitoring speed to which this monitoring speed margin was added.

The monitoring speed margin S_{mgn} is fixed to 1 [mm/s].

5.3.2 Limitations on the Use of the Test without Motor Function

The test without motor function of the SERVOPACK cannot be used together with the safety functions of the Safety Module. When using the safety functions, disable the test without motor function of the SERVOPACK being used. When using the test without motor function, set parameter Pc00 (Safety Function Selection Switch) of the Safety Module to “0000” (No safety functions). For details, refer to *Chapter 12 Appendix*.

5.3.3 Limitations on the Use of an External Encoder

An external encoder cannot be used together with the Safety Module, even if the external encoder is compatible with the servo drives. Disable the use of an external encoder for the SERVOPACK being used.

5.3.4 Device Combination

Due to the safety functions, the Safety Module can be used with limited models of SERVOPACKs, servomotors, and serial converters. For details, refer to *12.4 Device Combinations*.

5.4 Basic Settings Required before Starting Operation

The basic functions that must be set before starting operation are given below.

Step	Item		Reference
1	Disabling the external encoder		For details, refer to the manual for your SERVOPACK.
2	Disabling the test without motor function		
3	Rotational servomotor	Motor rotation direction	
	Linear servomotor	<ul style="list-style-type: none"> • Motor movement direction • Scale pitch • Motor Max. Speed 	
4	Rotational servomotor	Encoder output pulses	
	Linear servomotor	Encoder output resolution	
5	Safety-related Module Parameter Setting		
6	Safety-related Servo Parameter Updating		<i>8.4 Safety-related Servo Parameter Updating (Fn042)</i>
7	Safety Option Module Setup Alarm Clear		<i>8.6 Safety Option Module Setup Alarm Clear (Fn044)</i>

Note: Perform Steps 5 to 7 with the actual motor connected.

5.5 Checking the Operation

When starting the system or replacing a SERVOPACK for maintenance or inspection purposes, make sure that the relevant External Device Monitor Output Signal turns ON when the redundant Safety Request Input Signals turn OFF.

Failure of the safety functions can be detected by monitoring the Safety Request Input Signals and the External Device Monitor Output Signals.

The following table shows the logic for the Safety Request Input Signals and the External Device Monitor Output Signals.

Signal Name	Code	Logic			
Safety Request Input Signal A1	SRI-A1	ON	ON	OFF	OFF
Safety Request Input Signal A2	SRI-A2	ON	OFF	ON	OFF
External Device Monitor Output Signal A	EDM-A	OFF	OFF	OFF	ON

- Note 1. For details on the Safety Request Input Signals, refer to 6.2.2 *Safety Request Input Signals*.
- Note 2. For details on the External Device Monitor Output Signals, refer to 6.2.3 *External Device Monitor Output Signals*.
- Note 3. This logic is the same for the Safety Request Input Signal B.

Safety Functions

This chapter describes the Safety Functions of the Safety Module.

6.1 Overview	6-2
6.2 Common Items	6-3
6.2.1 Selecting a Safety Function	6-3
6.2.2 Safety Request Input Signals	6-4
6.2.3 External Device Monitor Output Signals	6-7
6.2.4 Operations After Alarms and Resetting Systems, and While Recalculating Parameters	6-10
6.2.5 Validating Safety Functions	6-11
6.3 Safe BaseBlock Function (SBB Function)	6-12
6.3.1 Basic Operation	6-12
6.3.2 Settings	6-12
6.3.3 Returning Method	6-12
6.3.4 Exceptional Operation	6-13
6.3.5 Related SERVOPACK Functions	6-14
6.4 Safe BaseBlock with Delay Function (SBB-D Function)	6-18
6.4.1 Basic Operation	6-18
6.4.2 Settings	6-20
6.4.3 Returning Method	6-20
6.4.4 Exceptional Operation	6-20
6.4.5 Related SERVOPACK Functions	6-21
6.5 Safe Position Monitor with Delay Function (SPM-D Function)	6-22
6.5.1 Basic Operation	6-22
6.5.2 Settings	6-24
6.5.3 Returning Method	6-24
6.5.4 Exceptional Operation	6-24
6.5.5 Related SERVOPACK Functions	6-25
6.6 Safely Limited Speed with Delay Function (SLS-D Function)	6-26
6.6.1 Basic Operation	6-26
6.6.2 Settings	6-28
6.6.3 Returning Method	6-28
6.6.4 Exceptional Operation	6-29
6.6.5 Related SERVOPACK Functions	6-29
6.7 Order of Priority of Safety Functions	6-30
6.8 Application Example of Safety Functions	6-32

6.1 Overview

The Safety Module is equipped with four functions to provide machine safety. These functions reduce risks during usage of the machine by protecting people from hazardous operations of movable machine parts. The stopping function that is defined in functional safety standards can be achieved with these four functions.

The Safety Module provides the following four safety functions.

Function	Description	Remarks	Reference
Safe BaseBlock Function (SBB function)	This function shuts OFF the power supply to the motor by executing the HWBB function of the SERVOPACK according to the state of the input signals.	This safety function is equivalent to the Safe Torque Off function that is defined in IEC 61800-5-2.	6.3
Safe BaseBlock with Delay Function (SBB-D function)	<ol style="list-style-type: none"> 1. This function monitors the deceleration of the motor until the specified time according to the state of the input signal. 2. It shuts OFF the power supply to the motor by executing the HWBB function of the SERVOPACK. 	This safety function is equivalent to the Safe Stop 1 function that is defined in IEC 61800-5-2.	6.4
Safe Position Monitor with Delay Function (SPM-D function)	<ol style="list-style-type: none"> 1. This function monitors the deceleration of the motor until the specified time according to the state of the input signal. 2. It monitors the position after the motor has stopped. 	This safety function is equivalent to the Safe Stop 2 function that is defined in IEC 61800-5-2.	6.5
Safely Limit Speed with Delay Function (SLS-D function)	<ol style="list-style-type: none"> 1. This function monitors the deceleration of the motor until the specified time according to the state of the input signal. 2. It monitors the motor speed to make sure that it is within the allowable range. 	This safety function is equivalent to the Safely-Limited Speed function that is defined in IEC 61800-5-2.	6.6

The Safety Module has two Safety Functions with the same features and these functions can be allocated separately. Each of these functions has a two input channels and one output channel. The safety function that is specified beforehand is executed according to the state of the input signal.

A schematic diagram of the functions is shown below.

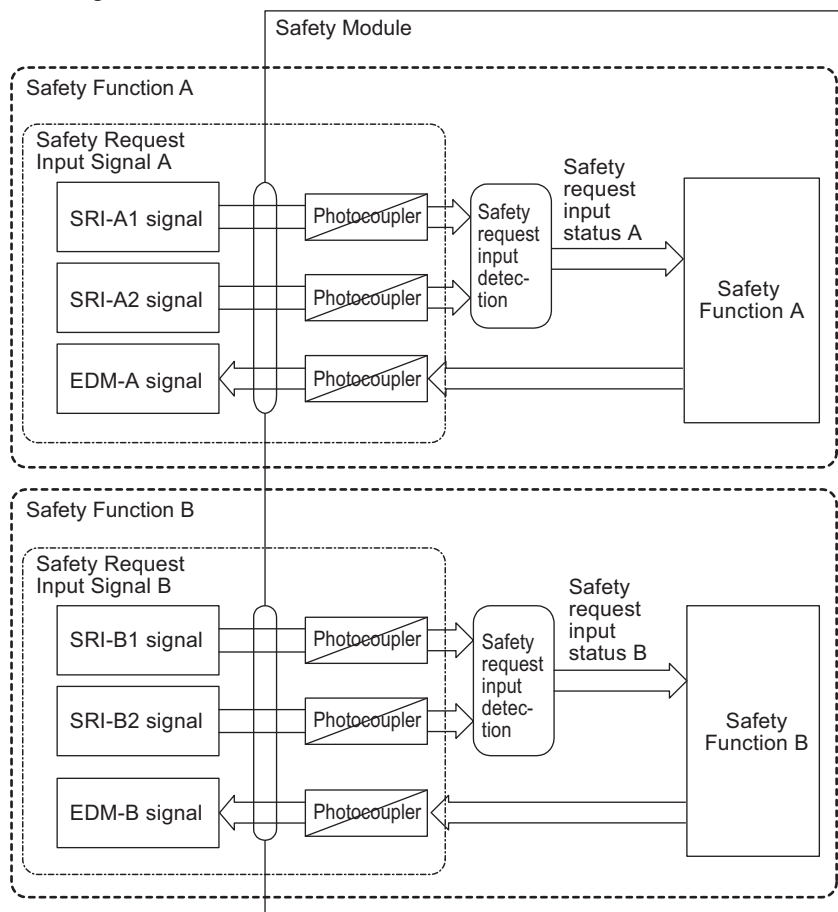

6.2 Common Items

6.2.1 Selecting a Safety Function

The Safety Module has two safety functions with the same features and these functions can be allocated separately. Either or both of these safety functions can be used.

The setup parameters of safety functions are as follows:

Parameter No.	Name	Setting Range	Units	Factory Setting	When Enabled
Pc00	Safety Function Selection Switch	–	–	0002	After resetting the system
Details	Safety Function Selection Basic Switch				
Pc00.0	Safety Function A Selection				
	0	No safety function.			
	1	Safe BaseBlock Function (SBB function)			
	2	Safe BaseBlock with Delay Function (SBB-D function) [factory setting]			
	3	Safe Position Monitor with Delay Function (SPM-D function)			
	4	Safely Limited Speed with Delay Function (SLS-D function)			
Pc00.1	Safety Function B Selection				
	0	No safety function [factory setting].			
	1	Safe BaseBlock Function (SBB function)			
	2	Safe BaseBlock with Delay Function (SBB-D function)			
	3	Safe Position Monitor with Delay Function (SPM-D function)			
Pc00.2	0	Reserved (Do not change.)			
	Apply Monitoring Speed Margin Selection				
Pc00.3	0	Applies the monitoring speed margin during deceleration monitoring and constant speed monitoring. [factory setting]			
	1	Applies the monitoring speed margin during deceleration monitoring only. The monitoring speed margin is not applied during constant speed monitoring.			

Note 1. For details on safety functions, refer to 6.3 *Safe BaseBlock Function (SBB Function)* through 6.6 *Safely Limited Speed with Delay Function (SLS-D Function)*.

2. The SERVOPACK functions will be limited when safety functions are used. For details, refer to 5.3 *Limitations*.

6.2.2 Safety Request Input Signals

(1) Safety Request Input Signals

Safety Request Input Signals initiate the execution of the safety functions. Safety functions are executed when a Safety Request Input Signal is input.

To improve safety, two Safety Request Input Signal channels are allocated to each safety function.

Safety Request Input Signal A

Signal Name	Signal State	Meaning
SRI-A1	ON	Cancels the safety function operation request.
	OFF	Requests operation of the safety function.
SRI-A2	ON	Cancels the safety function operation request.
	OFF	Requests operation of the safety function.

Note: This is the same for Safety Request Input Signal B.

(2) Safety Request Input State

The state when the Safety Module recognizes a request for operation of a safety function based on the state of the redundant Safety Request Input Signals is called the safety request input status.

Safety Request Input State	ON	Cancels the safety function execution request.
	OFF	Requests execution of the safety function.

Relationship between Safety Request Input Signal and Safety Request Input Status

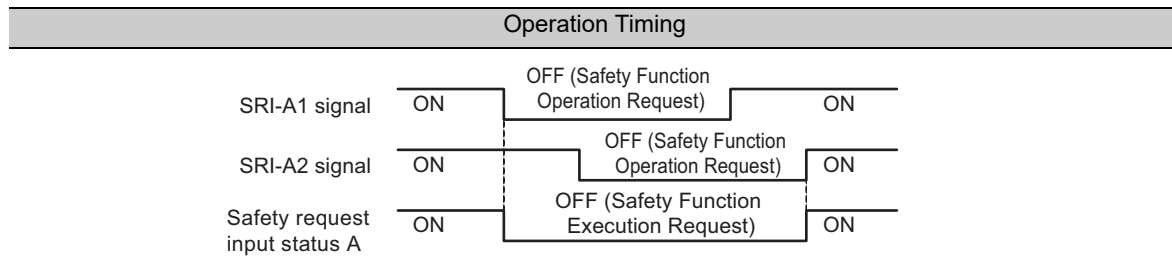

(3) Relationship between the Safety Request Input Signal and Safety Function

Relationship between the Safety Request Input Signal and Safety Function

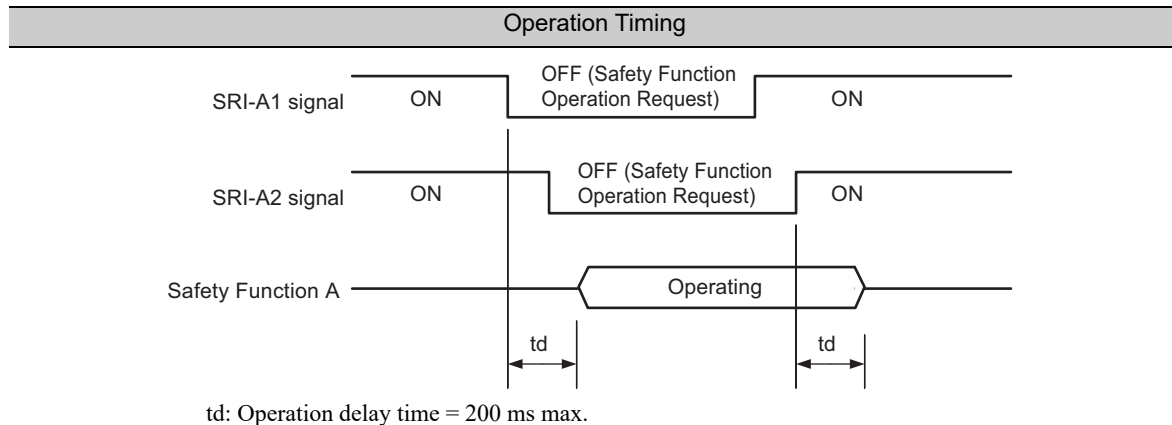

- Note 1. Make sure that the Safety Request Input Signal has a pulse width that is 200 ms or longer.
- 2. Safety Request Input Signal with a pulse width that is 0.5 ms or shorter cannot be detected.

(4) Error Detection for Safety Request Input Signals

The Safety Module monitors the state of redundant Safety Request Input Signals allocated to each safety function to detect errors.

The process of error detection is as follows:

1. The time period until the ON/OFF state of the redundant Safety Request Input Signals matches is measured.
2. If the measured time period exceeds the specified time period, an error is detected in the Safety Request Input Signal.
3. The power supply to the motor is shut OFF by executing the HWBB function of the SERVOPACK.

■ Time Measurement Timing

The timing of measuring the time period until the ON/OFF state of the redundant Safety Request Input Signals match is described below.

- Measurement starts when the edge of either the SRI-A1 signal or SRI-A2 signal is detected.
- The condition for ending measurement depends on the condition when measurement was started.

The conditions for starting and ending the measurement of time period are as follows:

Condition for Starting Measurement	Condition for Ending Measurement
When either the SRI-A1 signal or SRI-A2 signal changes from ON to OFF	Measurement ends when both the Safety Request Input Signals turn OFF.
When either the SRI-A1 signal or SRI-A2 signal changes from OFF to ON	Measurement ends when both the Safety Request Input Signals turn ON.

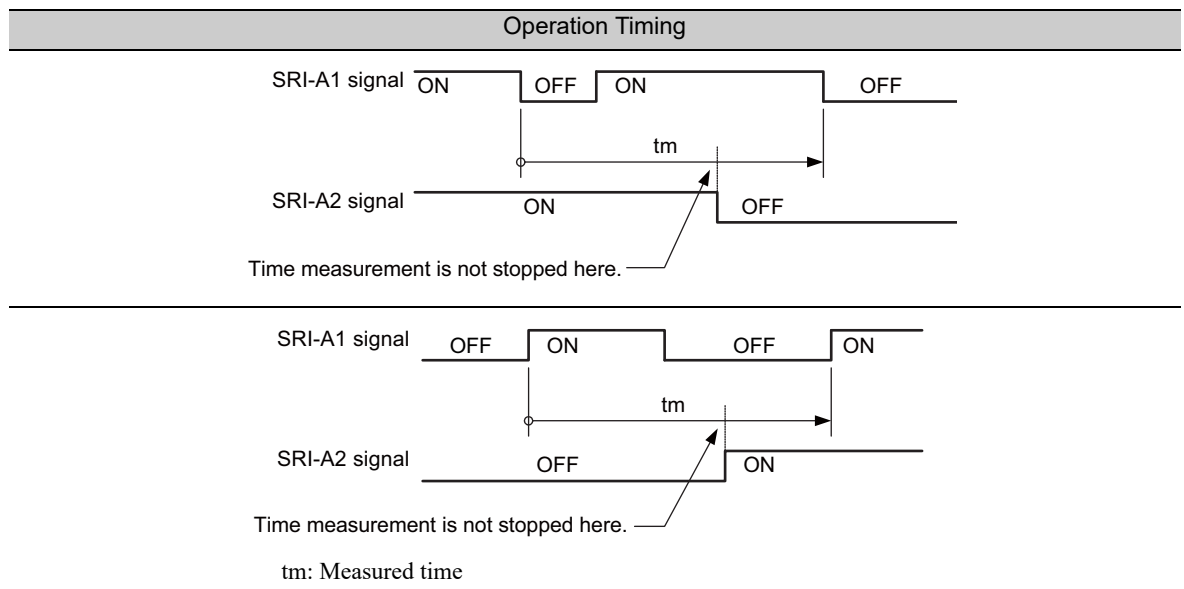

■ Alarms

The following alarms occur if an error is detected in the Safety Request Input Signals.

To cancel an alarm, remove the cause of the alarm, and then reset the system.

Alarm No.	Name	Description	Alarm Reset	Stopping Method
A.EB5	Safety Module: Timing Error of Safety Request Input Signal A	The ON/OFF state of the Safety Request Input Signals A1 and A2 did not match within the specified time period.	Not possible	According to the setting of Pn001.0*
A.EB6	Safety Module: Timing Error of Safety Request Input Signal B	The ON/OFF state of the Safety Request Input Signals B1 and B2 did not match within the specified time period.	Not possible	According to the setting of Pn001.0*

* For details on how to stop the motor, refer to the manual for your SERVOPACK.

The timing of the occurrence of an alarm when an error is detected in the Safety Request Input Signals is shown below.

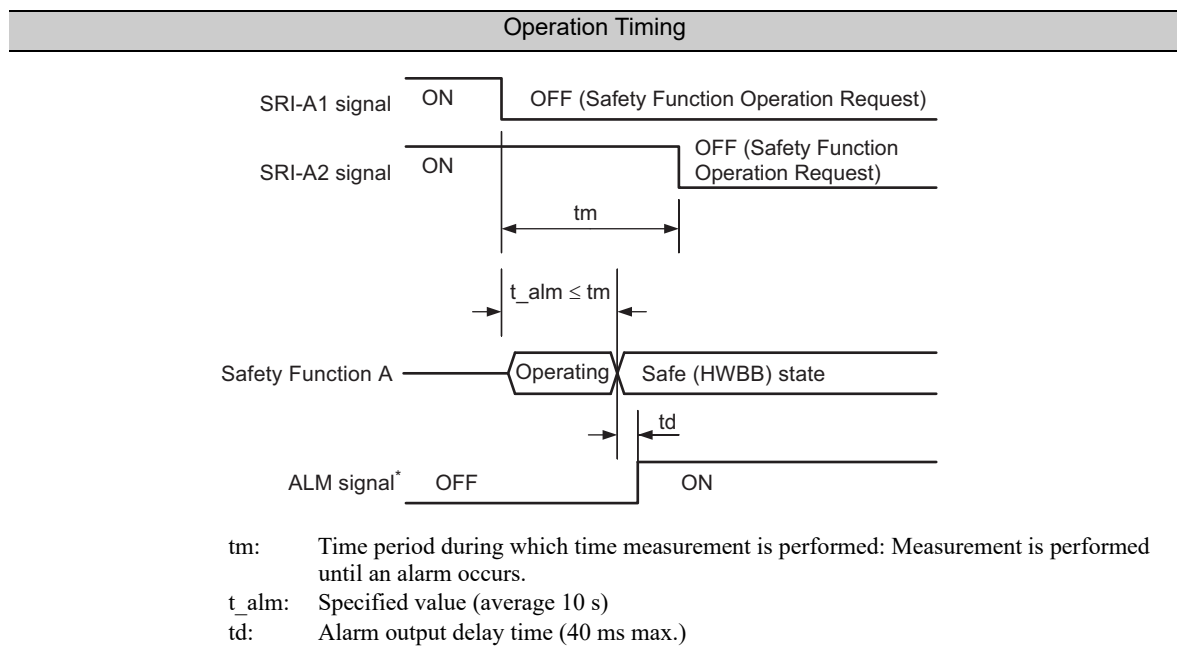

* For details on alarm signals, refer to the manual for your SERVOPACK.

6.2.3 External Device Monitor Output Signals

These signals are output when the following two conditions are met:

- The safety function is operating normally.
- No malfunction occurs in the safety function.

If a malfunction occurs in the safety function when the safety function is operating, this signal will not be output.

By monitoring this signal from an external device, a sequence can be designed for returning to normal operations from the safety function operation state.

The following figure shows the relationship between the External Device Monitor Signal and safety function.

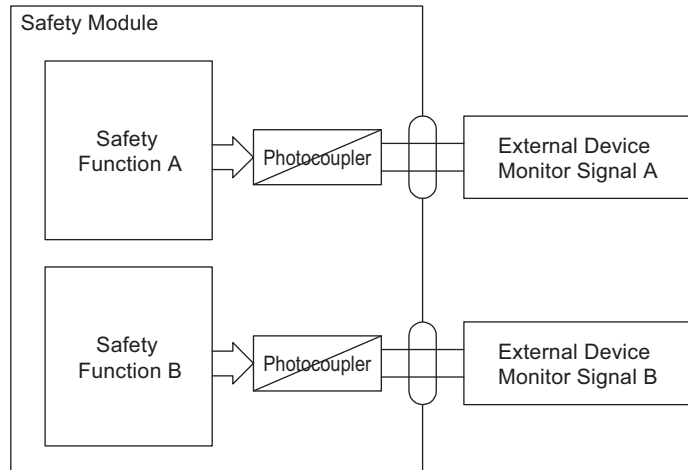

The specifications of the External Device Monitor Output Signal are as follows:

Signal Name	Output State	Meaning
External Device Monitor Output Signal A	ON	Safety Function A is operating normally and no malfunction occurs in the safety function.
	OFF	–
External Device Monitor Output Signal B	ON	Safety Function B is operating normally and no malfunction occurs in the safety function.
	OFF	–

(1) Output Conditions

The output signal turns ON when all of the following conditions are met:

- Application Safety Request Input Signals are OFF (Safety Function Operation Request).
- The safety function is either operating, or is in the safe state.
- Output of the External Device Monitor Signal is set by using parameters. For details, refer to (2) *Selecting Output Conditions*.
- No malfunction is being detected in the Safety Module.
- There is no malfunction in the safety-related parts of the SERVOPACK.
- A system reset or recalculation of parameters is not in progress.

(2) Selecting Output Conditions

The output conditions of the External Device Monitor Output Signals can be selected by using the parameters.

Parameter No.	Name	Setting Range	Units	Factory Setting	When Enabled
Pc01	EDM Signal Output Selection Switch	–	–	0011	After resetting the system
Details		EDM Signal Output Setting			
Pc01.0	EDM Signal A Output Setting				
	0	The EDM-A signal turns ON while the safety function of safety function A is operating.			
	1	The EDM-A signal turns ON while safety function A is in the safe state.* [default setting]			
Pc01.1	EDM Signal B Output Setting				
	0	The EDM-B signal turns ON while the safety function of safety function B is operating.			
	1	The EDM-B signal turns ON while safety function B is in the safe state.* [default setting]			
Pc01.2	Reserved (Do not change.)				
Pc01.3	Reserved (Do not change.)				

* The kind of the safe state depends on the type of the Safety Function used. For details, refer to Description of Technical Terms at the front of this manual.

An example of the output timing of External Device Monitor Output Signal is shown below.

■ When Pc01.0 = 0 (Output Condition = Safety Function Operation)

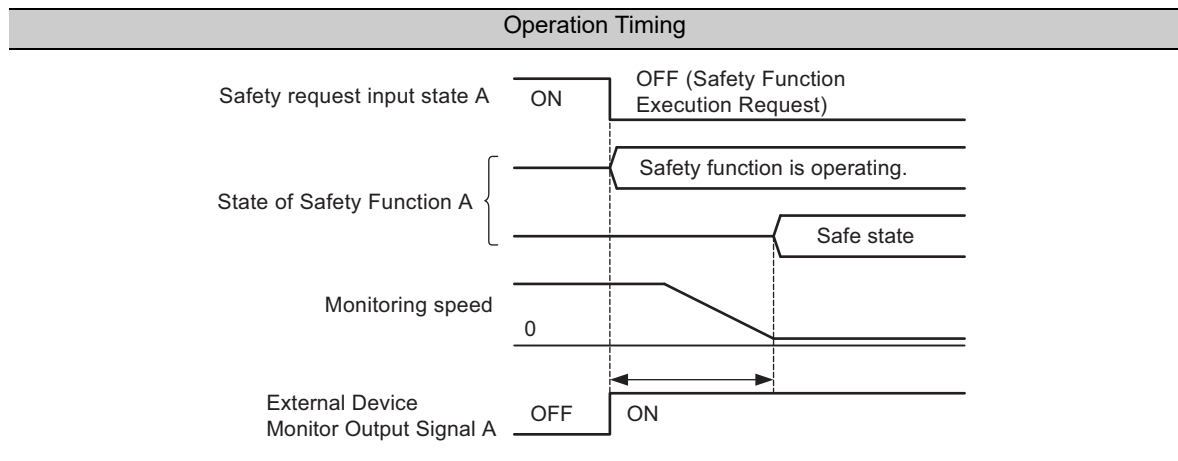

■ When Pc01.0 = 1 (Output Condition = Safe State)

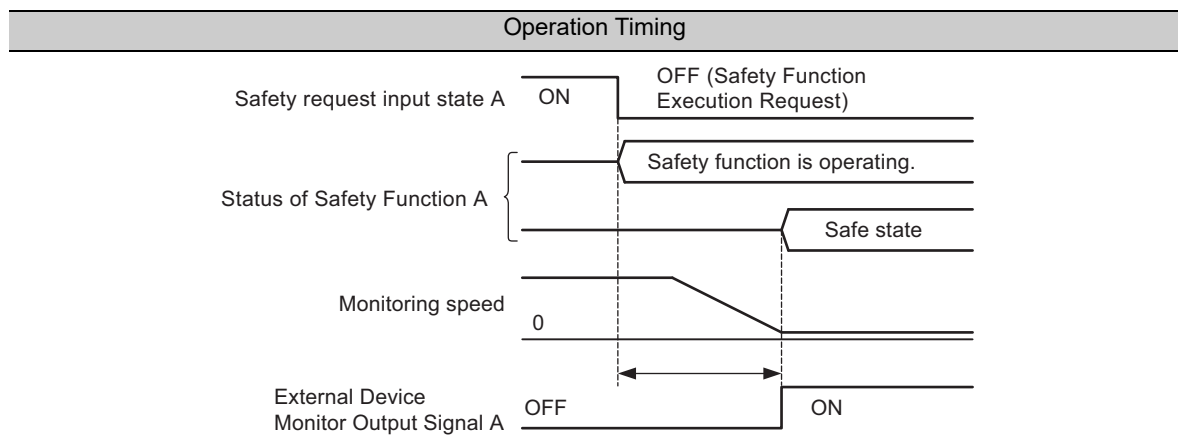

(3) Output Delay Time

The output delay time of the External Device Monitor Output Signals is shown below.

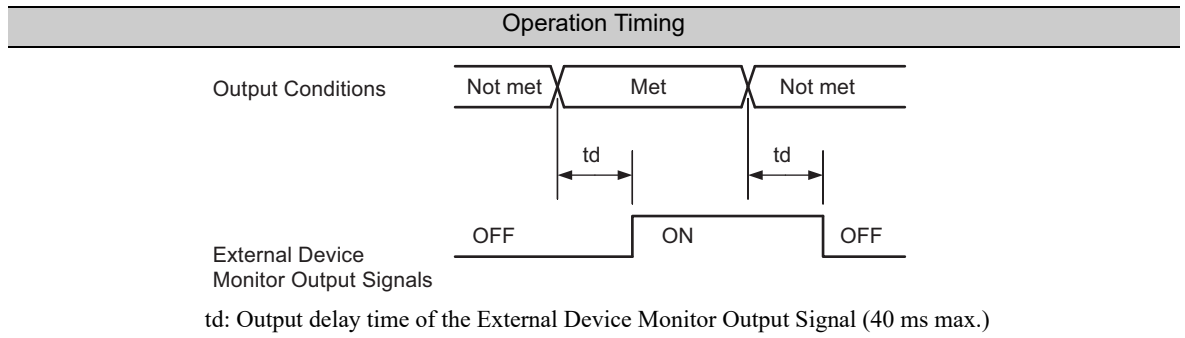

■ Timing Charts

The timing chart for each output condition is shown below.

Note: All other output conditions are met, and the output delay time is applicable.

a) When the Safety Request Input Signals A1 and A2 are OFF

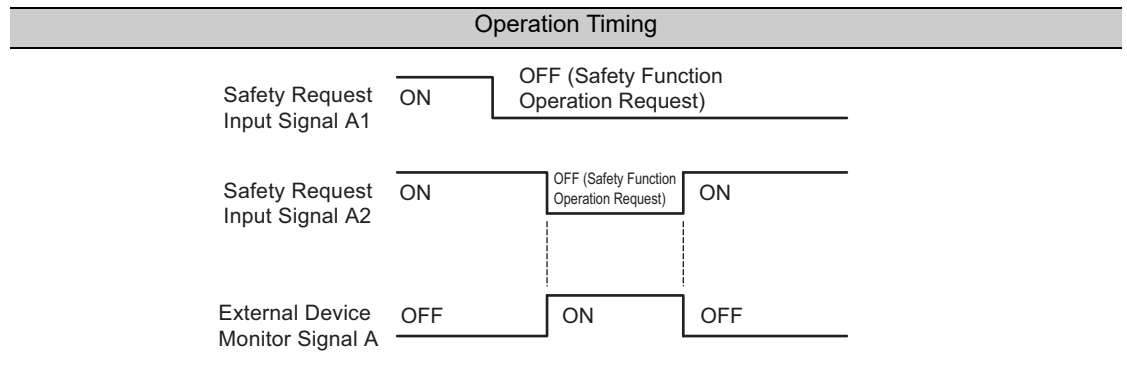

b) When a Malfunction Occurs in Safety Function A

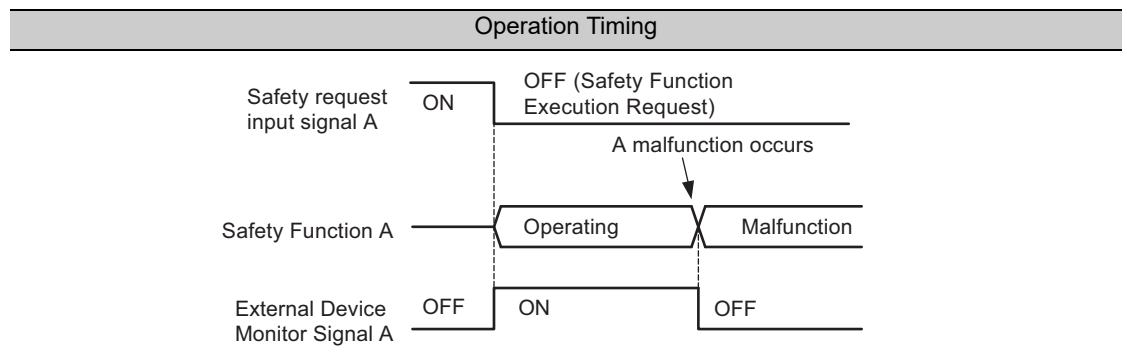

Note: Safety Function Operation is set as the output condition in this example. Regardless of the state of the Safety Request Input Signals, if a malfunction is detected in the safety function, the External Device Monitor Signal will turn OFF.

6.2.4 Operations After Alarms and Resetting Systems, and While Recalculating Parameters

The Safety Module operates in a different manner after the system is reset, an alarm occurs, or while parameters are recalculated.

(1) After Resetting the System

After the system is reset, the Safety Module forcibly shuts OFF the power supply to the motor by executing the HWBB function of the SERVOPACK. After the startup processes of the Safety Module and the SERVOPACK have been completed, the ALM signal of the SERVOPACK turns OFF and normal operation starts. The timing of system startup of Safety Module is shown below.

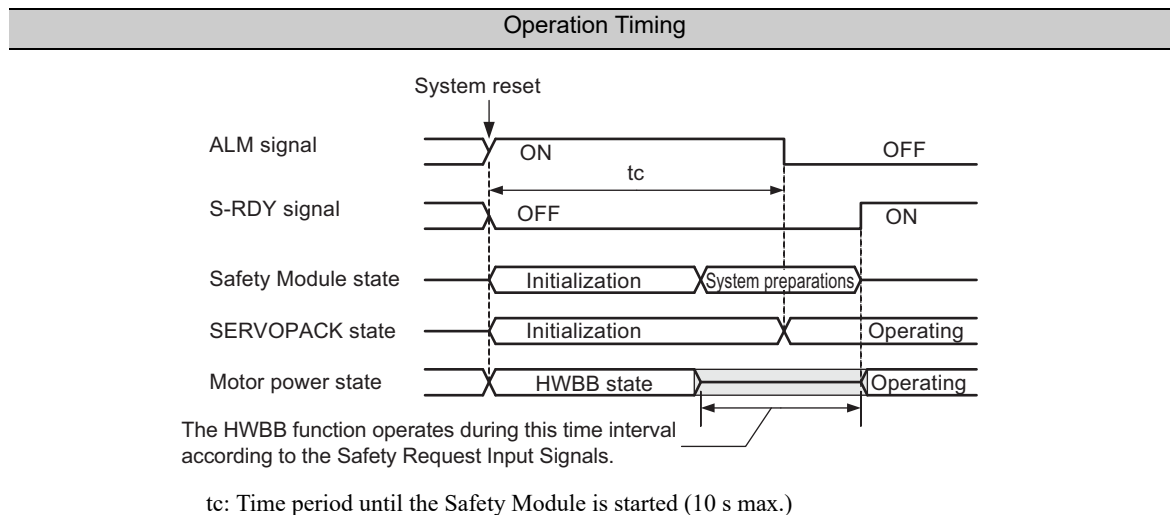

(2) While Recalculating Parameters

When parameters are being recalculated, the Safety Module shuts OFF the power supply to the motor by executing the HWBB function of SERVOPACK according to the safety request input state.

(3) After an Alarm Occurs

After an alarm occurs, the Safety Module shuts OFF the power supply to the motor by executing the HWBB function of the SERVOPACK regardless of the input state of the Safety Request Input Signals.

The timing of the execution of the HWBB function of the SERVOPACK during an alarm is shown below.

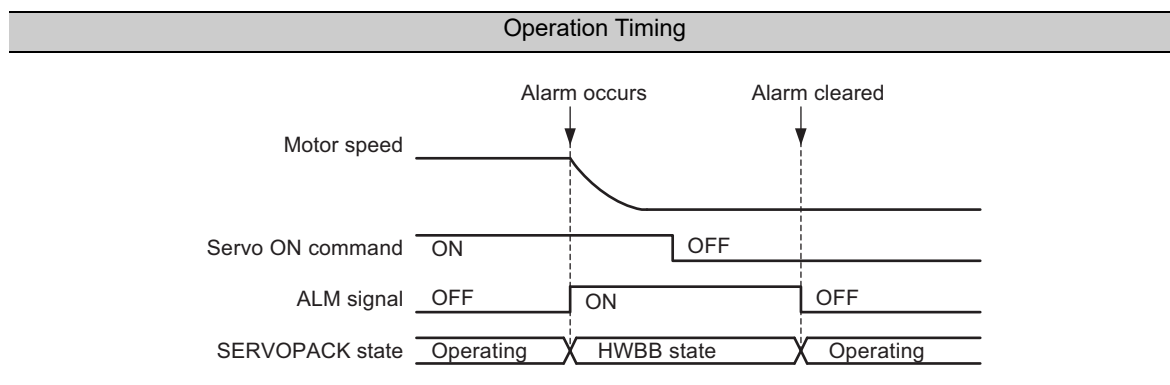

For details on alarms that are detected in the Safety Module, refer to *Chapter 11 Troubleshooting*.

To cancel the HWBB state after an alarm has occurred, perform the following:

- Remove the cause of the alarm.
- Set the safety request input state to ON.
- Set the servo ON command to OFF.

6.2.5 Validating Safety Functions

When you commission the system, replace a SERVOPACK or Safety Module for maintenance or inspection purposes, or change the parameter settings of a Safety Module, you must always perform the following validation test on the safety function after completing the wiring.

(It is recommended that you keep the confirmation results as a record.)

- The logic of the Safety Request Input Signals and the External Device Monitor Output Signal operates as shown in the following table.

Signal Name	Code	Logic			
Safety Request Input Signal A1	SRI-A1	ON	ON	OFF	OFF
Safety Request Input Signal A2	SRI-A2	ON	OFF	ON	OFF
External Device Monitor Output Signal A	EDM-A	OFF	OFF	OFF	ON

Note 1. For details on the Safety Request Input Signals, refer to 6.2.2 *Safety Request Input Signals*.

2. For details on the External Device Monitor Output Signals, refer to 6.2.3 *External Device Monitor Output Signals*.

3. This logic is the same for the Safety Request Input Signal B.

- When signals /SRI-A1 and /SRI-A2, or /SRI-B1 and /SRI-B2 are switched between ON and OFF, make sure that the bits assigned to Un016 operate properly.
 - ⇒ For details on Un016, refer to 9.2.1 *Safety Module I/O Signal Monitor (Un016)*.
 - ⇒ If the ON/OFF timing of the signals does not match or if the signals are not operating, the external wiring may have been disconnected or there may be a short-circuit. Another possible reason is malfunctioning of the safety equipment or SERVOPACK. Find the cause and take proper action.
- If signals /SRI-A1 and /SRI-A2, or /SRI-B1 and /SRI-B2 turn OFF, EDM-A or EDM-B must turn ON after the specified time elapses.
- If signals /SRI-A1 and /SRI-A2, or /SRI-B1 and /SRI-B2 turn ON, the motor must operate properly according to the reference from the host controller.
- The safety function in the customer's machine works properly according to the parameter settings and the state of the Safety Request Inputs.
- If parameter settings are changed, it is recommended that you keep a record of the parameter settings and the validation test results.

6.3 Safe BaseBlock Function (SBB Function)

6.3.1 Basic Operation

The Safe BaseBlock Function (hereafter called the SBB function) operates based on Safe Torque Off (STO) function that is defined in IEC 61800-5-2. This function shuts OFF the power supply to the motor by executing the HWBB function of the SERVOPACK according to the safety request input state.

The safe state in the SBB function indicates the safe (HWBB) state in which the power supply to the motor has been shut OFF.

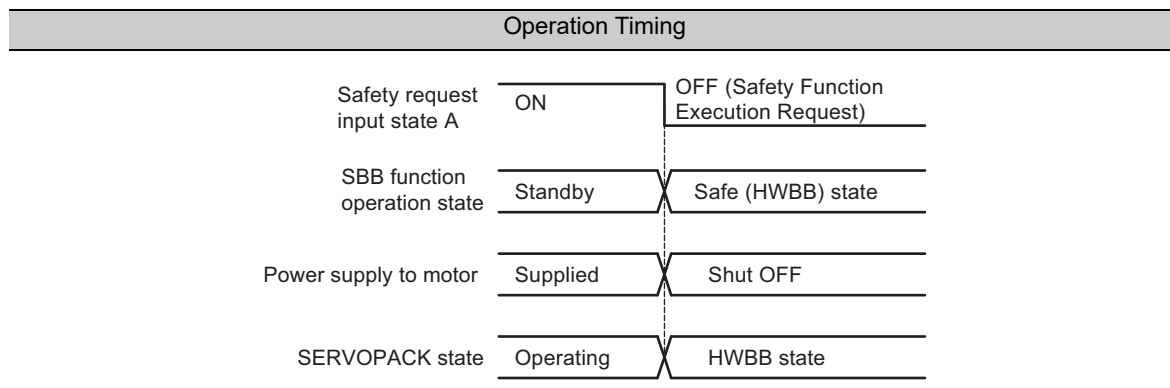

6.3.2 Settings

To use the SBB function, make the settings for using the SBB function of either Safety Function A or Safety Function B in the parameters. For details on the settings of the safety functions, refer to 6.2.1 *Selecting a Safety Function*.

6.3.3 Returning Method

(1) Returning Conditions

When the SERVOPACK state changes to the safe (HWBB) state by the SBB function, the safe (HWBB) state can be cleared to return to normal operation when all of the following conditions are met.

- The input states of all safety request must be ON.
- The servo ON command must be OFF.
- The polarity detection request must not be input to the SERVOPACK.
- The following utility functions for turning ON the servo must not be executed.

The utility functions for turning ON the servo are as follows:

Utility Function No.	Function Name
Fn002	Jog Operation
Fn003	Origin Search
Fn004	Program Jog Operation
Fn00E	Automatic Offset-signal Adjustment of the Motor Current Detection Signal
Fn080	Polarity Detection
Fn201	Advanced Autotuning
Fn206	EasyFFT

Note: If any of these utility functions are being executed, the utility function must be terminated first. Return to either the main menu of utility function mode with a digital operator or the utility function selection screen with a panel operator to terminate it. Refer to the *Σ-V Series User's Manual Operation of Digital Operator*, the *Σ-7 Series Digital Operator Operating Manual*, or the manual for your SERVOPACK for more details.

(2) Returning Timing

■ When the Servo ON Command Is Not Input

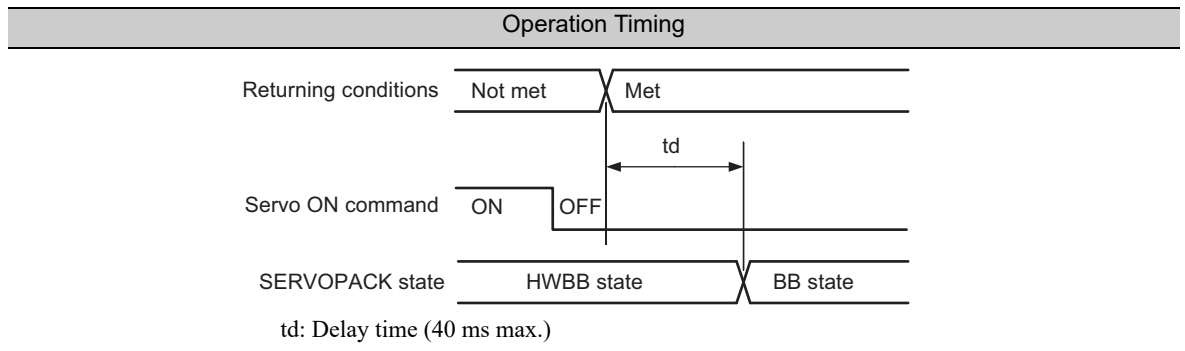

■ When the Servo ON Command Is Input

When the safety request input status is ON, the SBB function stops operating. However, if the servo ON command is input at that point, the SERVOPACK continues in the HWBB state. To return to normal operation, the servo must be turned OFF to change the SERVOPACK to the BB status. For details on restoring the operation of the SERVOPACK, refer to the manual for your SERVOPACK.

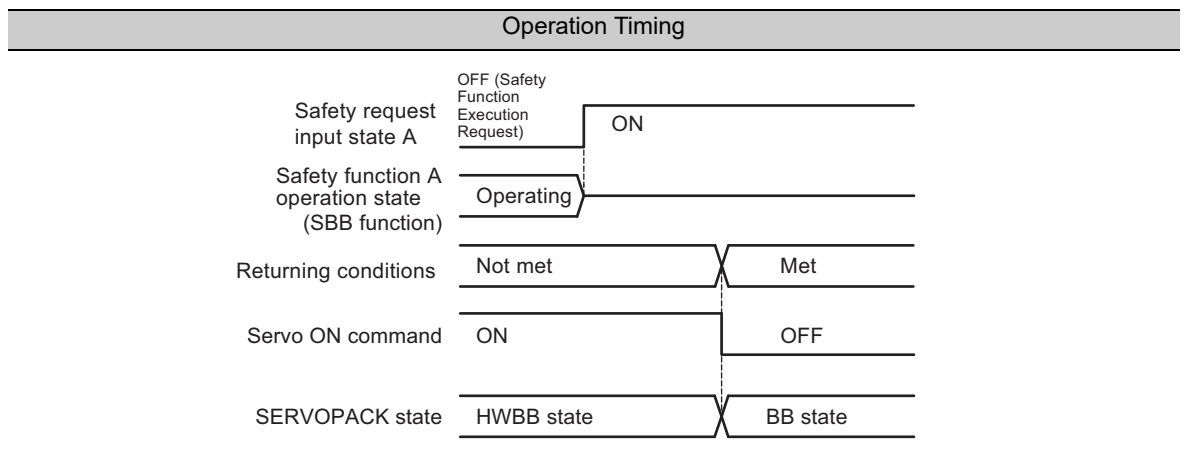

6.3.4 Exceptional Operation

(1) After Resetting the System

After the system is reset, the SBB function is executed according to the Safety Request Input Signals during completion of the initialization processing.

For details on how to return to normal operation from the HWBB state, refer to 6.3.3 *Returning Method*.

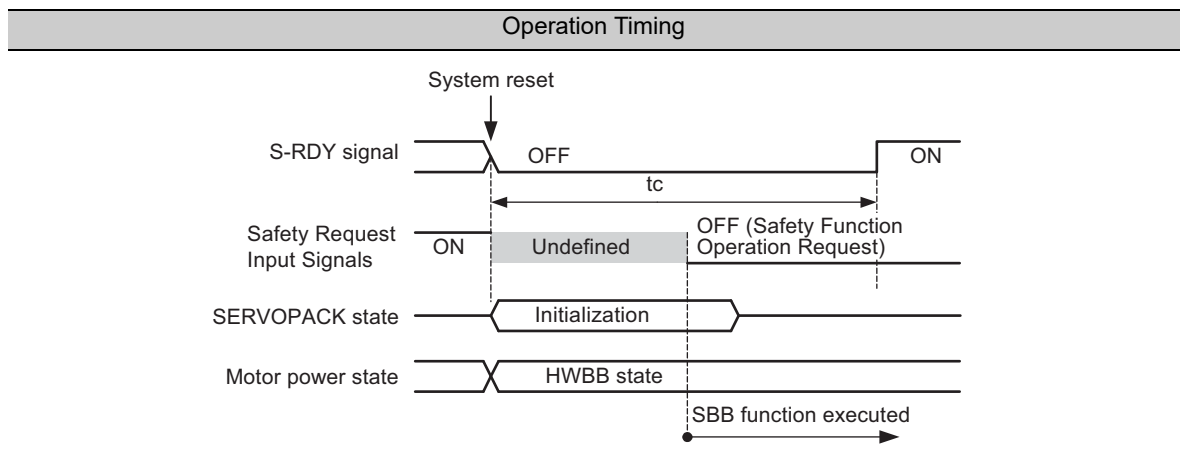

(2) While Recalculating Parameters

When parameters are being recalculated, the SBB function is executed according to the Safety Request Input Signal after recalculation of parameters.

For details on how to return to normal operation from the HWBB state, refer to *6.3.3 Returning Method*.

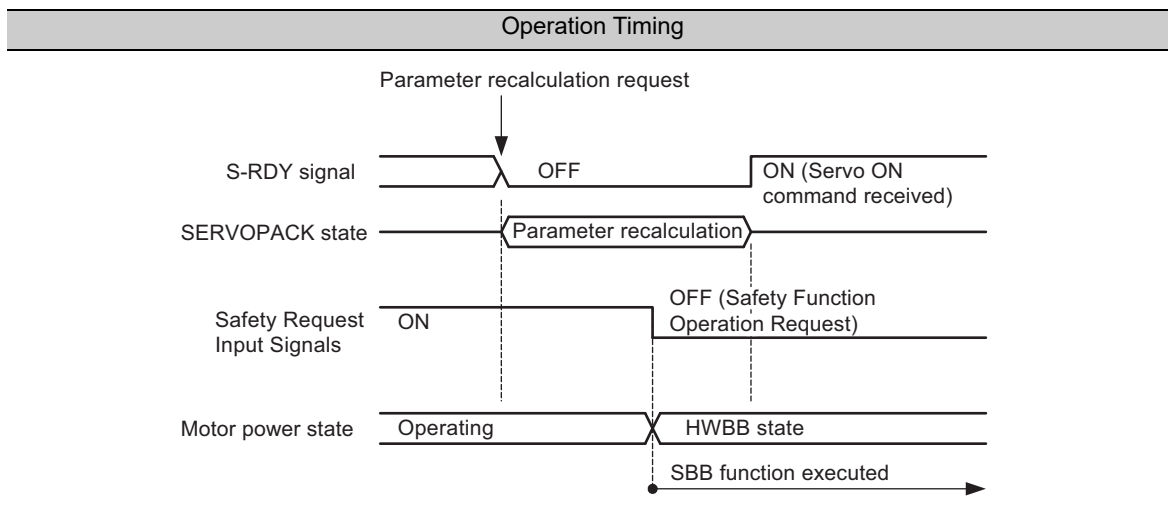

6.3.5 Related SERVOPACK Functions

The SERVOPACK functions and operations related to the operation of the SBB function are described below. For details, refer to the manual for your SERVOPACK.

- Always servo ON setting
- Motor stop mode
- Zero-speed setting
- Overtravel
- Servo ready signal
- Brake sequence
- Relationship with MECHATROLINK-II commands
- Relationship with MECHATROLINK-III commands
- Relationship with MECHATROLINK-4 commands

(1) Always Servo ON Setting

If the Always Servo ON status is set for the SERVOPACK, the HWBB state cannot be cleared. When using the Safety Module, do not use the Always Servo ON setting in the SERVOPACK.

(2) Motor Stop Mode

When the SBB function is operating, the motor will stop according to the method specified in the SERVOPACK parameter Pn001.0 (Application Function Select Switch 1).

Parameter No.	Set Value	Stop Mode	Motor after Stopping
Pn001.0	0	Dynamic brake	Dynamic brake
	1	Dynamic brake	Coast
	2	Coast	Coast

(3) Zero-speed Stopping

■ When the SBB Function is Turned ON (Operating) while Zero-speed Stopping

When the SBB function is turned ON while zero-speed stopping (during a GR2 alarm), zero-speed stopping is canceled and the motor is stopped according to the method specified in parameter Pn001.0 (Application Function Select Switch).

Note: For details on the Gr2 alarm, refer to the manual for your SERVOPACK.

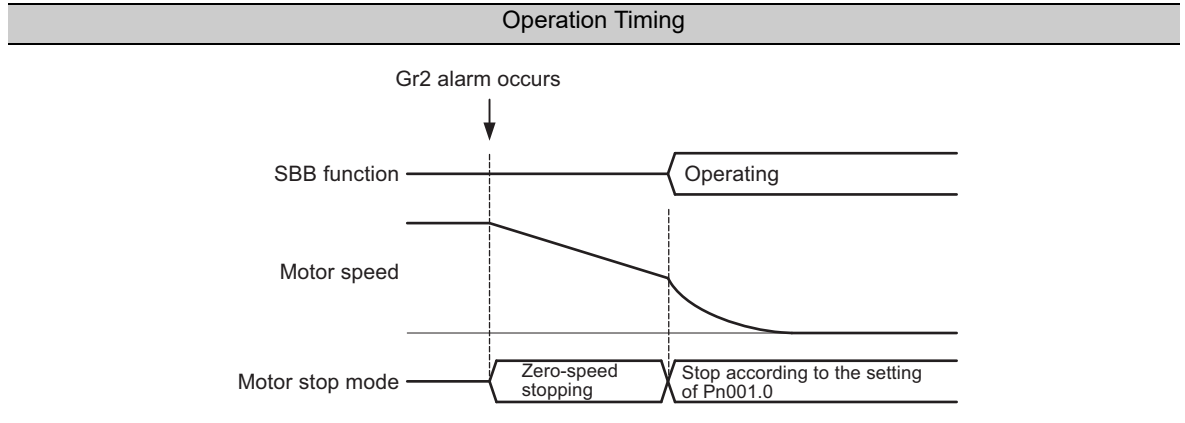

■ When a Gr2 Alarm Occurs while the SBB Function Is Operating

When a Gr2 alarm occurs while the SBB function is operating, the motor is not stopped by zero-speed stopping. Instead, the stopping method specified in Pn001.0 (Application Function Select Switch) is used.

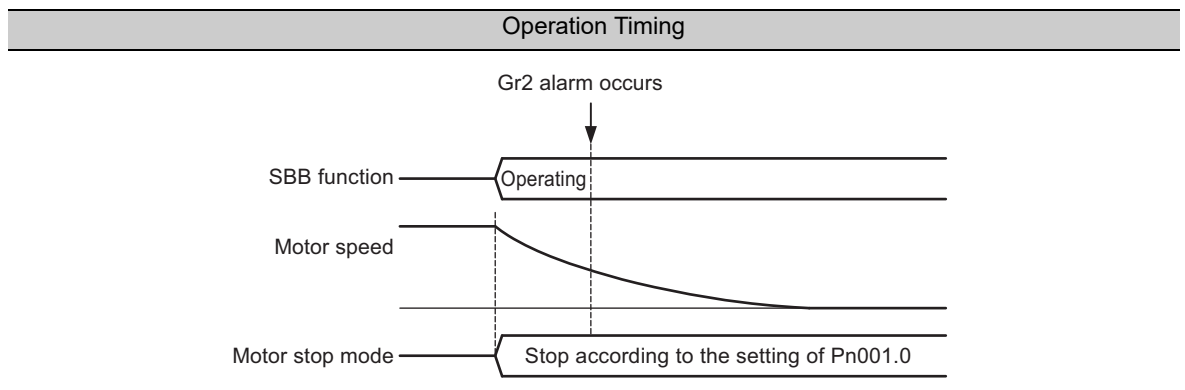

(4) Overtravel

When the SBB function operates during overtravel, the motor is stopped with the method specified in parameter Pn001.0 (Application Function Select Switch). The overtravel function does not operate while the SBB function is operating.

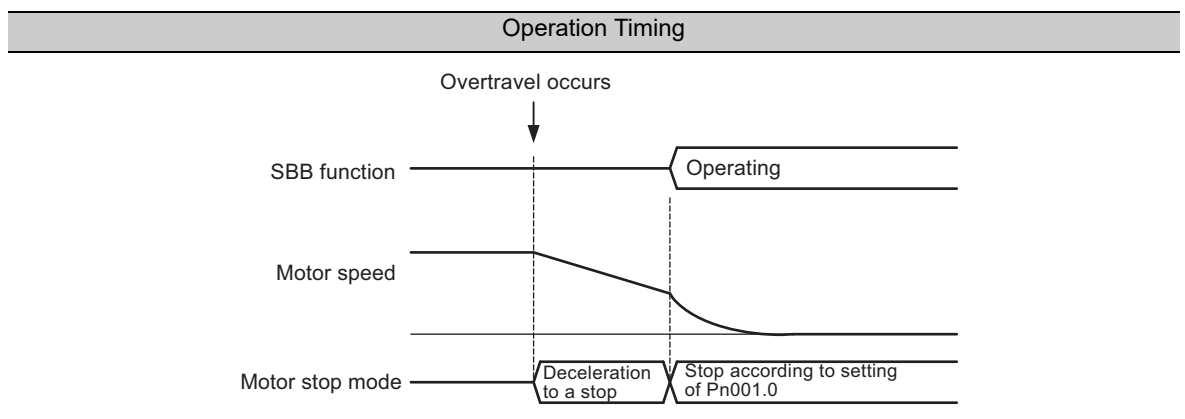

(5) Servo Ready Signal

When the SBB function is operating, the Servo Ready Signal turns OFF (i.e., the servo cannot be turned ON) during operation of the SBB function. After returning from the HWBB state, the Servo Ready Signal turns ON (i.e., the servo can be turned ON).

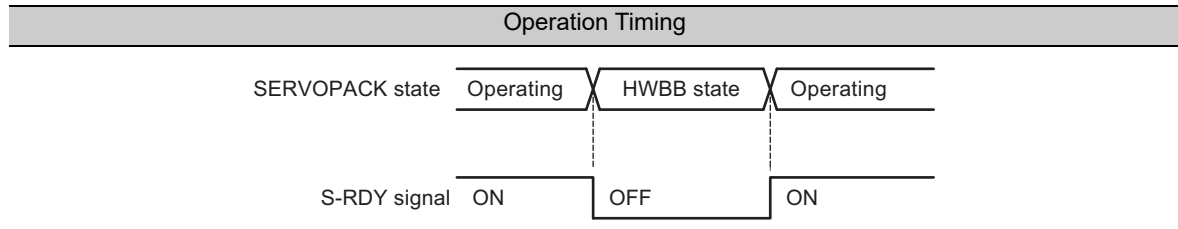

(6) Brake Sequence

When the SBB function is operating, the SERVOPACK parameter Pn506 (Brake Reference-Servo OFF Delay Time) is disabled, and the SERVOPACK changes to the HWBB state.

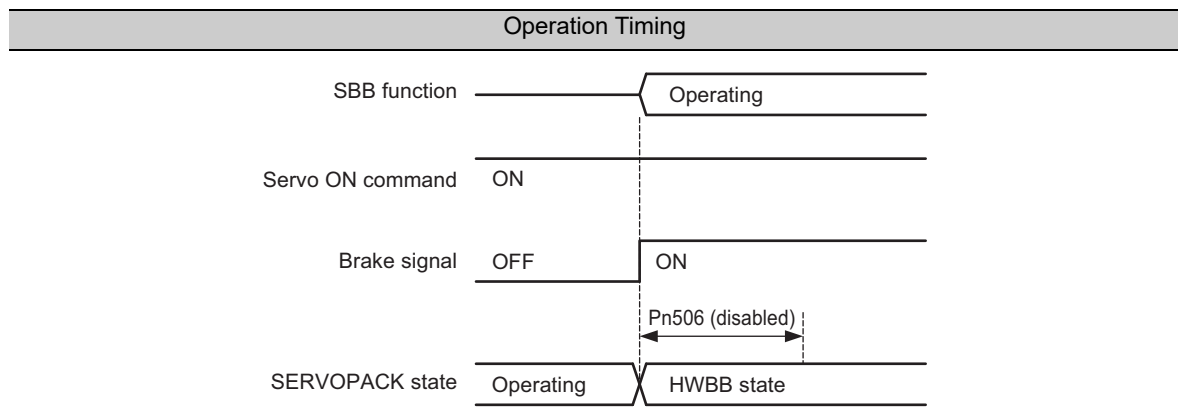

(7) Relationship with MECHATROLINK-II Commands

If the SERVOPACK changes to the HWBB state during the execution of any of the following MECHATROLINK-II commands, a command warning will occur. If a warning occurs, reset the alarm and then return to normal operation.

MECHATROLINK-II Commands Related to the SBB Function

Command	Function Name
SV_ON	Servo ON
INTERPOLATE	Interpolation
POSING	Positioning
FEED	Constant-speed Feeding
LATCH	Interpolation with Position Detection
EX_POSING	External Input Positioning
ZRET	Homing

(8) Relationship with MECHATROLINK-III Commands

If the SERVOPACK changes to the HWBB state during the execution of any of the following MECHATROLINK-III commands, a command warning will occur. A command warning will also occur if a MECHATROLINK-III command now being executed is canceled with the CMD_CANCEL (cancellation of move command) control bit.

If a warning occurs, cancel the HWBB state first, and then send a new motion command, or disable the CMD_CANCEL control bit to resume the operation.

MECHATROLINK-III Commands Related with SBB Function

Command	Function Name
SV_ON	Servo ON
INTERPOLATE	Interpolation
POSING	Positioning
FEED	Constant speed feed
EX_POSING	Positioning by external input command
EX_FEED	Positioning at constant speed by external input command
ZRET	Zero point return

(9) Relationship with MECHATROLINK-4 Commands

If the SERVOPACK changes to the HWBB state during the execution of any of the following MECHATROLINK-4 commands, a command warning will occur. A command warning will also occur if a MECHATROLINK-4 command now being executed is canceled with the CMD_CANCEL (cancellation of move command) control bit.

If a warning occurs, cancel the HWBB state first, and then send a new motion command, or disable the CMD_CANCEL control bit to resume the operation.

MECHATROLINK-4 Commands Related with SBB Function

Command	Function Name
SV_ON	Servo ON
INTERPOLATE	Interpolation
POSING	Positioning
FEED	Constant speed feed
EX_POSING	Positioning by external input command
EX_FEED	Positioning at constant speed by external input command
ZRET	Zero point return
CF_POSCTRL	CF Position Control

6.4 Safe BaseBlock with Delay Function (SBB-D Function)

6.4.1 Basic Operation

The Safety BaseBlock with Delay Function (hereafter called the SBB-D function) operates based on the Safe Stop 1 (SS1) function that is defined in IEC 61800-5-2. This function monitors the deceleration operation (deceleration monitoring) of the motor according to the safety request input state until the time period specified in the parameter elapses, and then shuts OFF the power supply to the motor by executing the HWBB function of the SERVOPACK.

The safe state in the SBB-D function indicates the safe (HWBB) state in which the power supply to the motor has been shut OFF.

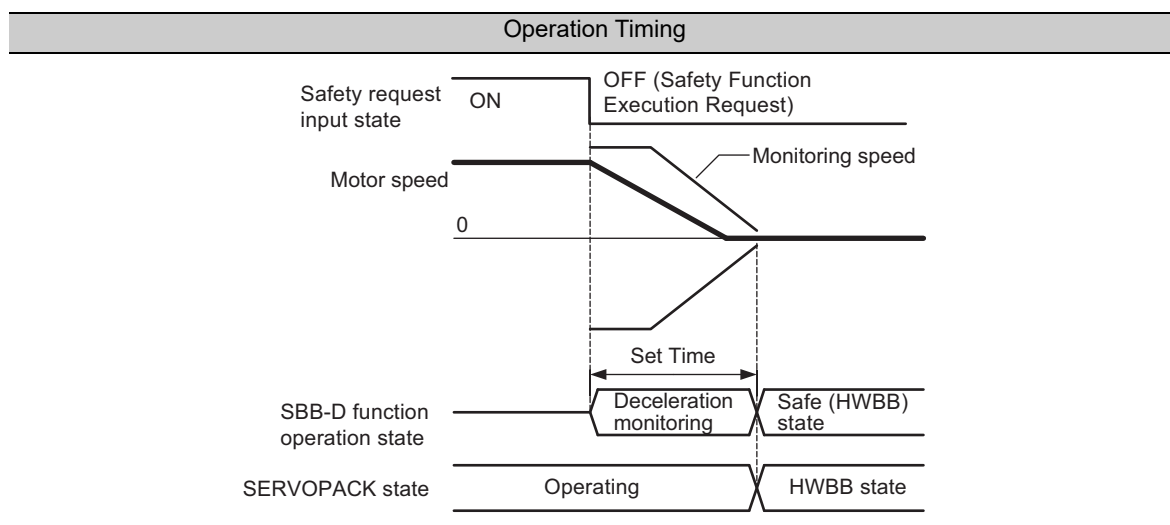

■ Operation during Deceleration Monitoring

• Alarms

When the motor speed exceeds the monitoring speed during deceleration monitoring, the following alarms occur. When an alarm is detected, motor speed monitoring is ended, following which the HWBB function of the SERVOPACK is executed and the power supply to the motor is shut OFF. Because these alarms are not an indication of any malfunction in the Safety Module, the External Device Monitor Output Signal will be ON.

Alarm No.	Name	Description	Alarm Reset	Stopping Method
A.EB7	Safety Module: Safety Function A Monitoring Alarm	The motor speed has exceeded the monitoring speed specified for Safety Function A. Alternatively, the distance that the motor moved has exceeded the allowable distance for monitoring that was specified for Safety Function A.	Available	According to the setting of Pn001.0
A.EB8	Safety Module: Safety Function B Monitoring Alarm	The motor speed has exceeded the monitoring speed specified for Safety Function B. Alternatively, the distance that the motor moved has exceeded the allowable distance for monitoring that was specified for Safety Function B.	Available	According to the setting of Pn001.0

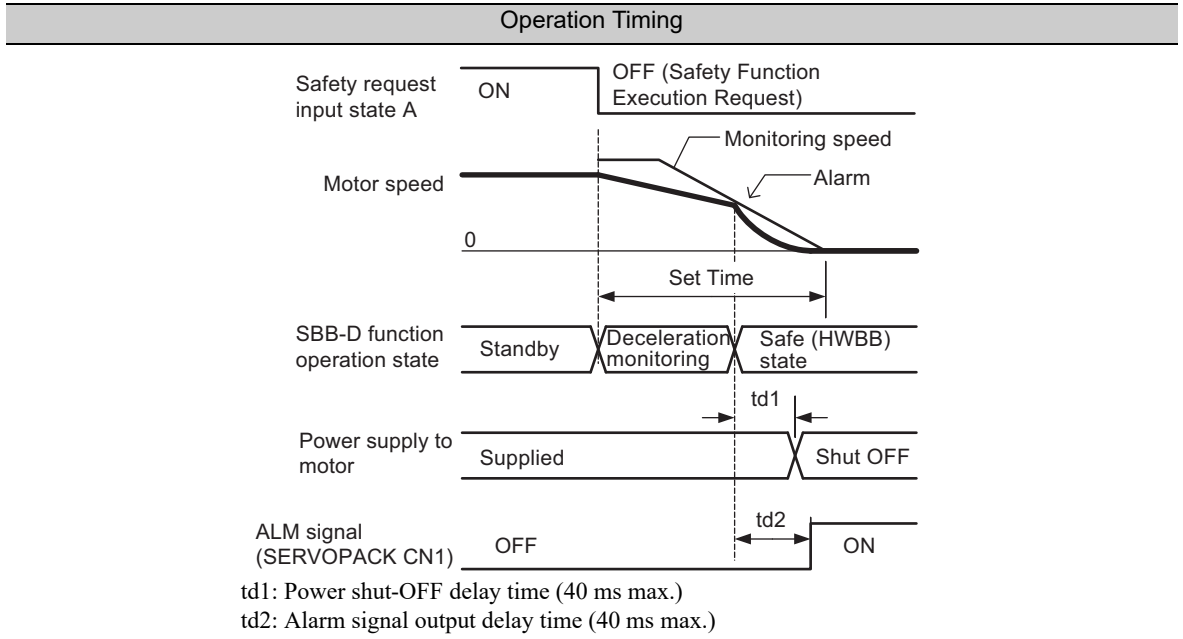

• Related Parameters

The schematic diagram and related parameters for monitoring the speed are shown below.

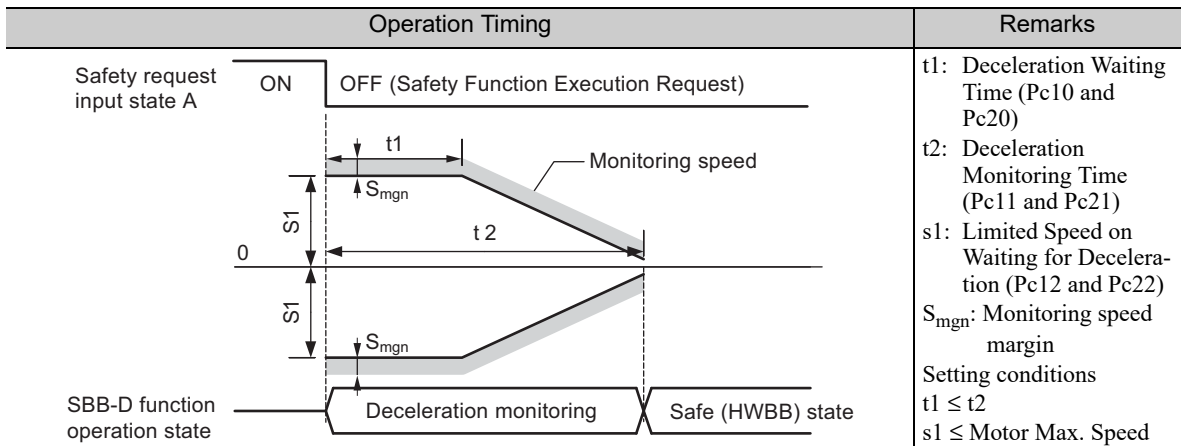

Parameter No.	Name	Setting Range	Units	Factory Setting	When Enabled
Pc10	Deceleration Waiting Time A (Safety Function A)	0 to 10000	10 ms	0	After resetting the system
Pc11	Deceleration Monitoring Time A (Safety Function A)	0 to 10000	10 ms	500	After resetting the system
Pc12	Limited Speed A on Waiting for Deceleration (Safety Function A)	0 to 10000	Rotational motor: min ⁻¹ Linear motor: mm/s	0	After resetting the system
Pc20	Deceleration Waiting Time B (Safety Function B)	0 to 10000	10 ms	0	After resetting the system
Pc21	Deceleration Monitoring Time B (Safety Function B)	0 to 10000	10 ms	500	After resetting the system
Pc22	Limited Speed B on Waiting for Deceleration (Safety Function B)	0 to 10000	Rotational motor: min ⁻¹ Linear motor: mm/s	0	After resetting the system

- Note 1. The deceleration waiting time (t1) cannot be longer than the deceleration monitoring time (t2). If it is longer, alarm A.EB2 (Safety Module: Parameter Setting Error) will occur.
2. The deceleration waiting monitoring speed (s1) cannot be faster than the Motor Max. Speed. If it is faster, alarm A.EB2 (Safety Module: Parameter Setting Error) will occur.
3. A monitoring speed margin (S_{mgn}) that takes into account the speed detection accuracy is added to the monitoring speed during deceleration monitoring. For the value of the monitoring speed margin, refer to 5.3.1 Limitations on Lower Limit of Encoder Output Pulses.

6.4.2 Settings

To use the SBB-D function, make the settings for using the SBB-D function of either Safety Function A or Safety Function B in the parameters. For details on the settings of the safety functions, refer to *6.2.1 Selecting a Safety Function*.

6.4.3 Returning Method

The method of returning to normal operation depends on the operation state of the SBB-D function.

(1) During Deceleration Monitoring

The SERVOPACK will return to normal operation when the input state of safety request is turned to ON.

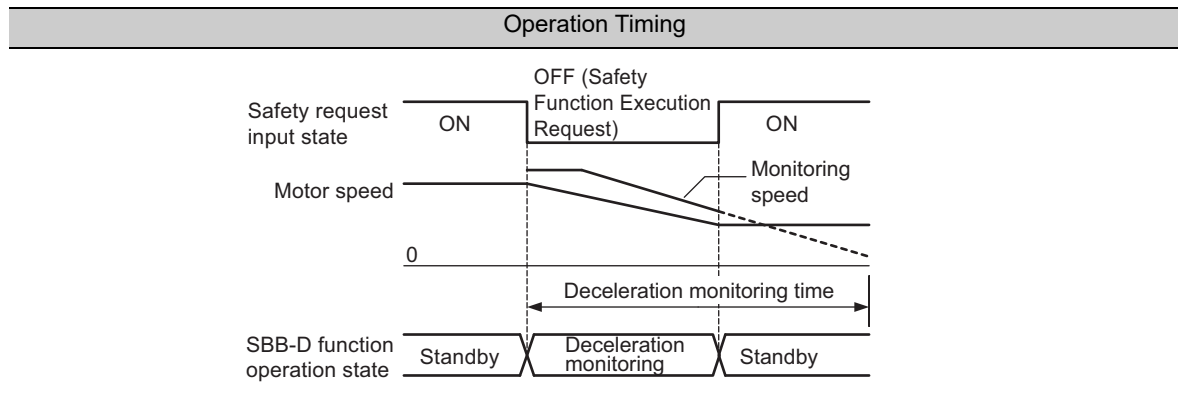

(2) During Safe (HWBB) State

The method of returning to normal operation after deceleration monitoring has ended and the SERVOPACK has changed to the safe (HWBB) state is the same as that for the SBB function. For details, refer to *6.3.3 Returning Method*.

6.4.4 Exceptional Operation

(1) After Resetting the System

The operation after the system is reset is the same as the operation after the system is reset for the SBB function. For details, refer to *6.3.4 Exceptional Operation*.

(2) While Recalculating Parameters

The operation when parameters are being recalculated is the same as the operation when parameters are being recalculated for the SBB function. For details, refer to *6.3.4 Exceptional Operation*.

6.4.5 Related SERVOPACK Functions

The SERVOPACK functions and operations related to the safe (HWBB) state after deceleration monitoring are the same as that for the SBB function. These are listed below. For details, refer to 6.3.5 *Related SERVOPACK Functions*.

- Always servo ON setting
- Motor stop mode
- Zero-speed stopping
- Overtravel
- Servo ready signal
- Brake sequence
- Relationship with MECHATROLINK-II commands
- Relationship with MECHATROLINK-III commands
- Relationship with MECHATROLINK-4 commands

Other related SERVOPACK functions are described below.

(1) Utility Functions

When the SBB-D function is being executed, any adjustments made with the following functions will not be successfully completed.

Execute these functions when the SBB-D function is not operating.

Utility Functions Related to the SBB-D Function

Utility Function No.	Function Name
Fn00A	Manual Servo Tuning of Speed Reference Offset
Fn00B	Manual Servo Tuning of Torque Reference Offset
Fn00F	Manual Offset-signal Adjustment of the Motor Current Detection Signal
Fn01B	Vibration Detection Level Initialization
Fn202	Advanced Autotuning by Reference
Fn203	One-parameter Tuning
Fn204	Anti-resonance Control Adjustment Function
Fn205	Vibration Suppression Function
Fn207	Online Vibration Monitor

(2) SEN Signal, Encoder Power Supply OFF (SENS_OFF), Sensor OFF (SENS_OFF)

If the following operations are performed while the Servo Ready Signal (S-RDY) is OFF, the SBB function will be operated instead of the safety function selected at Pc00.

If the Safety Request Input Signal turns OFF while the SBB function is operating, the SERVOPACK will enter a safe (HWBB) state.

- Turning OFF the SEN signal (analog voltage and pulse train reference model)
- Encoder power supply OFF (SENS_OFF) command (M-II communications reference model)
- Sensor OFF (SENS_OFF) command (M-III communications reference model and M-4 communications reference model)

6.5 Safe Position Monitor with Delay Function (SPM-D Function)

6.5.1 Basic Operation

The Safe Position Monitor with Delay Function (hereafter called the SPM-D function) operates based on the Safe Stop 2 (SS2) function that is defined in IEC 61800-5-2. This function monitors the deceleration operation (deceleration monitoring) of the motor according to the safety request input state until the time period specified in the parameter elapses, and then switches to position monitoring and monitors the distance that the motor moved to make sure it is within the allowable range.

The safe state resulting from use of the SPM-D function indicates the state during position monitoring.

The HWBB function of the SERVOPACK is executed when the specified speed is exceeded during deceleration monitoring or when the distance that the motor moved exceeds the allowable range during position monitoring. In either case, the power supply to the motor is shut OFF. If so, the safe state resulting from use of the SPM-D function indicates the state during the power supply to the motor has been shut OFF.

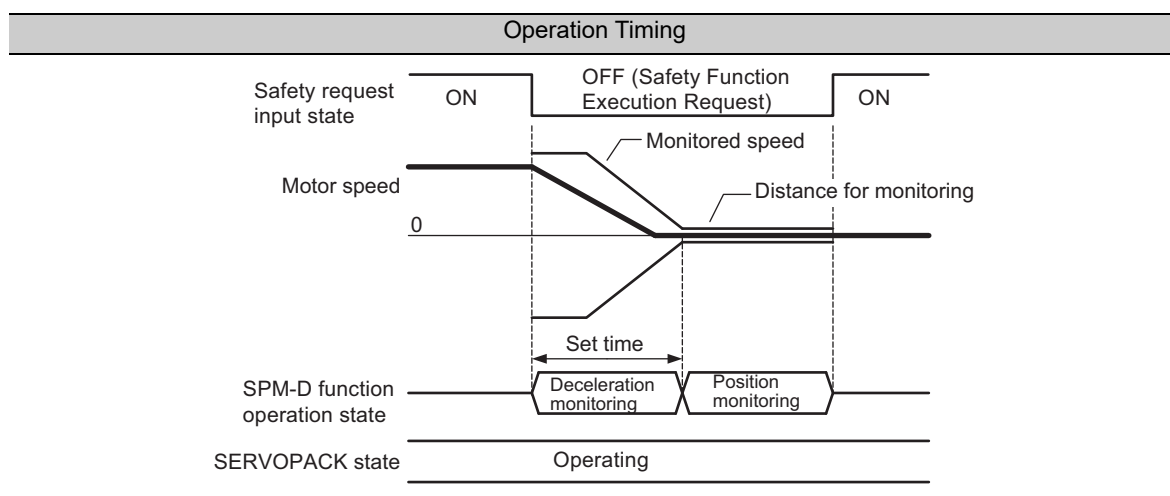

■ Operation during Deceleration Monitoring

The operation when the motor speed exceeds the monitoring speed during deceleration monitoring is the same as the operation during speed monitoring of the SBB-D function. For details, refer to ■ *Operation during Deceleration Monitoring* in 6.4.1.

■ Operation during Position Monitoring

• Alarms

When the motor position exceeds the distance for monitoring specified in the parameters during position monitoring, the following alarms occur. When an alarm is detected, position monitoring is ended, following which the HWBB function of the SERVOPACK is executed and the power supply to the motor is shut OFF. Because these alarms are not an indication of any malfunction in the Safety Module, the External Device Monitor Output Signal will be ON.

Alarm No.	Name	Description	Alarm Reset	Stopping Method
A.EB7	Safety Module: Safety Function A Monitoring Alarm	The motor speed has exceeded the monitoring speed specified for Safety Function A. Alternatively, the distance that the motor moved has exceeded the allowable distance for monitoring that was specified for Safety Function A.	Available	According to the setting of Pn001.0
A.EB8	Safety Module: Safety Function B Monitoring Alarm	The motor speed has exceeded the monitoring speed specified for Safety Function B. Alternatively, the distance that the motor moved has exceeded the allowable distance for monitoring that was specified for Safety Function B.	Available	According to the setting of Pn001.0

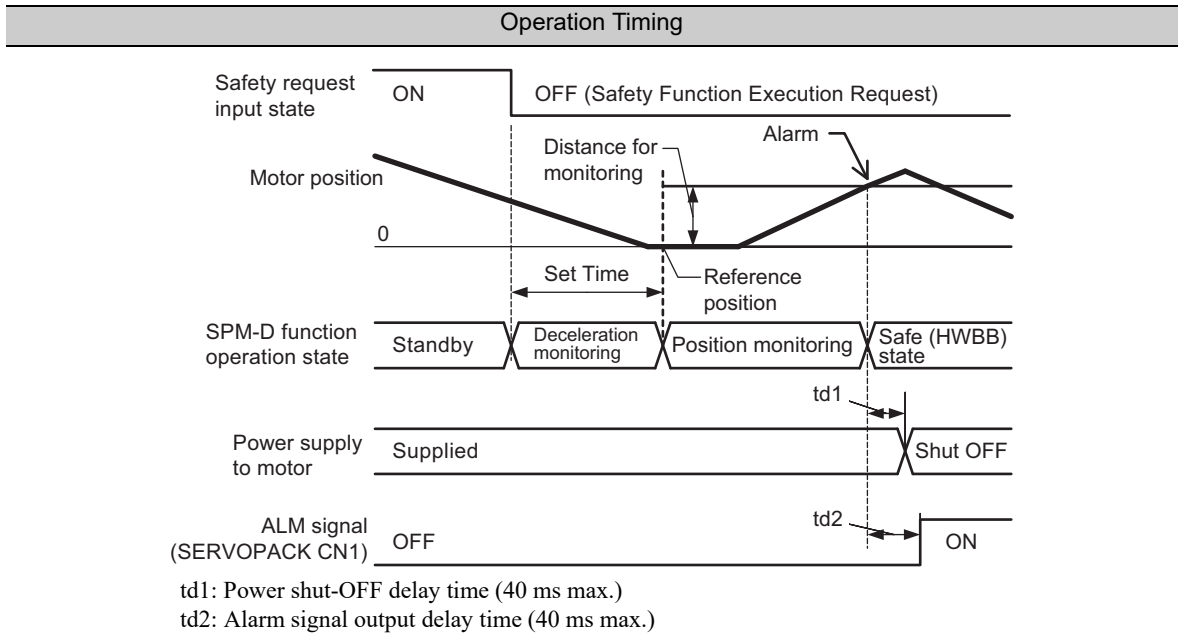

• Related Parameters

Parameters related to the distance for monitoring are described below. The edge of encoder output pulse that is output from the SERVOPACK is used as the unit when setting the distance for monitoring.

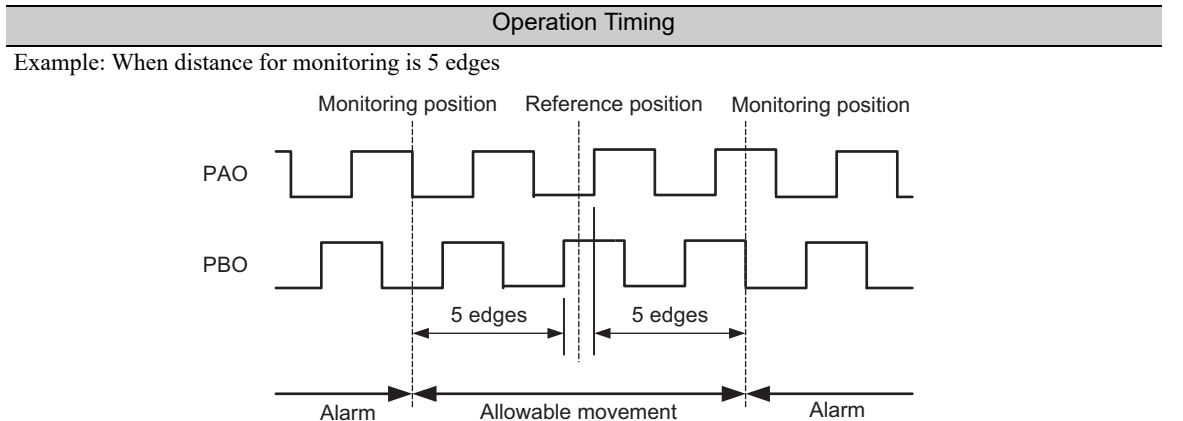

Parameter No.	Name	Setting Range	Units	Factory Setting	When Enabled
Pc13	Limited Distance A (Safety Function A)	1 to 65535	edge	10	After resetting the system
Pc23	Limited Distance B (Safety Function B)	1 to 65535	edge	10	After resetting the system

Because the output pulse count of the encoder output pulses for one rotation (or for one scale pitch) can be specified in the SERVOPACK parameters, the detectable distance that the motor moved will differ from that set for the parameter.

The relationship between the set value of encoder output pulses and the detectable distance that the motor moved is described below:

- The smaller the set value of encoder output pulses, the higher the detection accuracy of the distance that the motor moved.
- The larger the set value of encoder output pulses, the lower the detection accuracy of the distance that the motor moved.

For details on the set value of encoder output pulses and the distance that the motor moved per edge, refer to information on setting the encoder output pulse in the user's manual of the SERVOPACK being used.

6.5.2 Settings

To use the SPM-D function, make the settings for using the SPM-D function of either Safety Function A or Safety Function B in the parameters. For details on selecting the safety functions, refer to *6.2.1 Selecting a Safety Function*.

6.5.3 Returning Method

The method of returning to normal operation depends on the operation state of the SPM-D function.

(1) During Deceleration Monitoring or Position Monitoring

The SERVOPACK will return to normal operation when the input state of safety request is turned to ON.

(2) During Safe (HWBB) State

The method of returning after an alarm has occurred and the SERVOPACK has changed to the safe (HWBB) state is the same as that for the SBB function. For details, refer to *6.3.3 Returning Method*.

6.5.4 Exceptional Operation

(1) After Resetting the System

After the system is reset, if the Safety Request Input Signal turns OFF (Safety Function Execution Request) when the S-RDY signal turns OFF, the Safety Module performs position monitoring instead of deceleration monitoring.

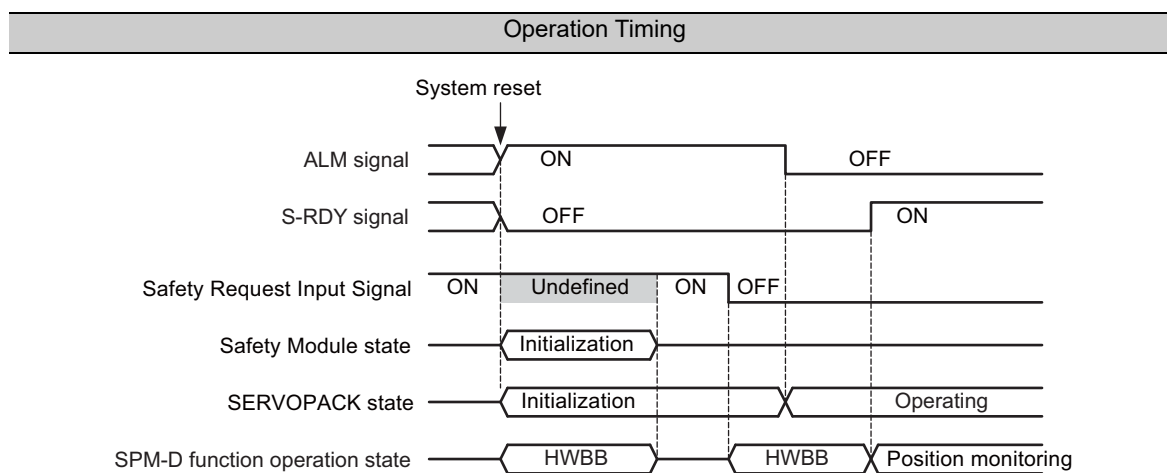

(2) While Recalculating Parameters

Similar to the CONFIG command for MECHATROLINK-II/-III/-4 communications, if the Safety Request Input Signal turns OFF (Safety Function Execution Request) when the S-RDY signal turns OFF during parameter recalculation, position monitoring is performed instead of deceleration monitoring.

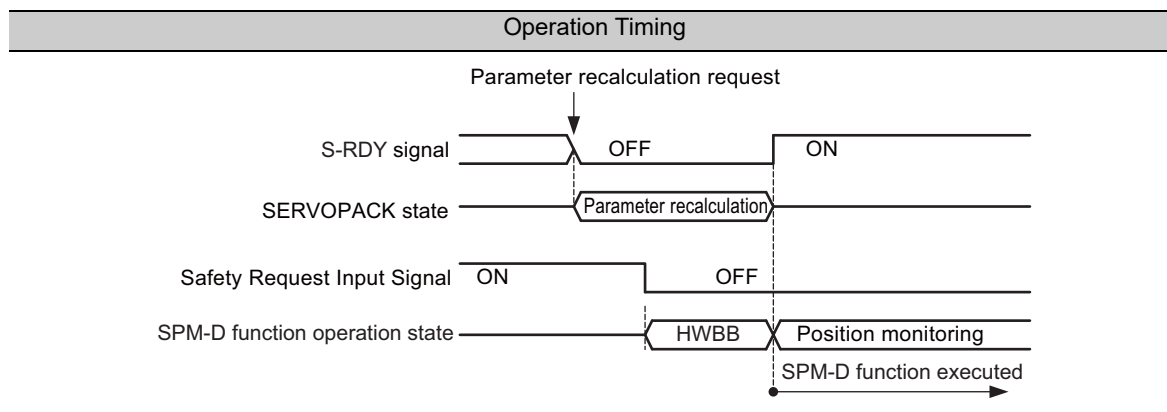

6.5.5 Related SERVOPACK Functions

The SERVOPACK functions and operations related to the operation of the SPM-D function are same as that for the SBB-D function. There are listed below. For details, refer to 6.4.5 *Related SERVOPACK Functions*.

- Always servo ON setting
- Motor stop mode
- Zero-speed stopping
- Overtravel
- Servo ready signal
- Brake sequence
- Relationship with MECHATROLINK-II commands
- Relationship with MECHATROLINK-III commands
- Relationship with MECHATROLINK-4 commands
- Utility functions
- SEN signal, encoder power supply OFF (SENS_OFF), sensor OFF (SENS_OFF)

6.6 Safely Limited Speed with Delay Function (SLS-D Function)

6.6.1 Basic Operation

The Safely Limited Speed with Delay Function (hereafter called the SLS-D function) operates based on Safely-Limited Speed (SLS) that is defined in IEC 61800-5-2. This function monitors the deceleration operation (deceleration monitoring) of the motor according to the safety request input state until the time period specified in the parameter elapses, and then monitors the motor speed to make sure it is within the allowable range (within a constant speed range).

The safe state in the SLS-D function indicates the state when the motor speed is within the allowable range.

If the specified speed is exceeded during motor speed monitoring, the power supply to the motor is shut OFF by executing the HWBB function of the SERVOPACK. If so, the safe state resulting from use of the SLS-D function indicates the state during the power supply to the motor has been shut OFF.

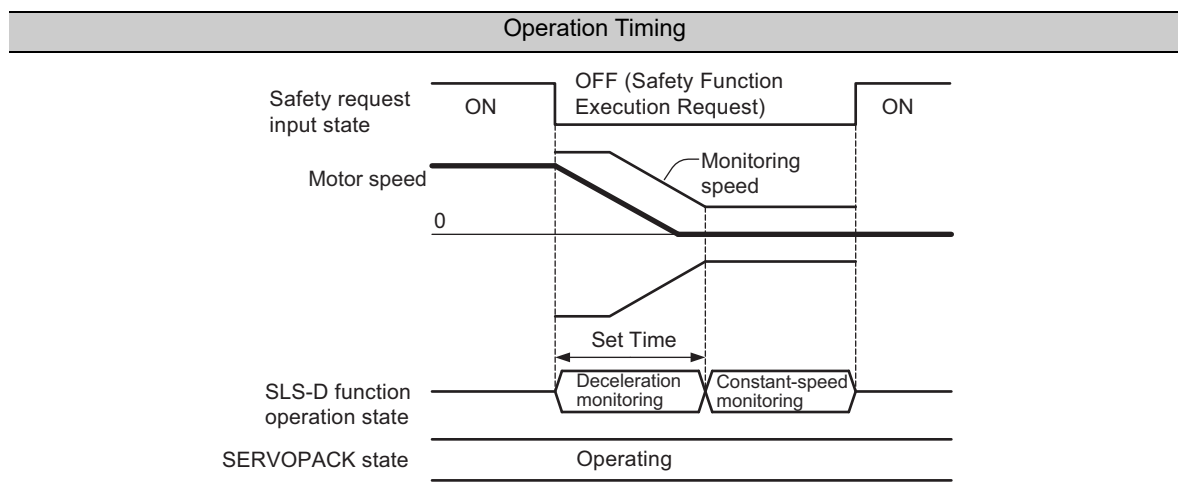

■ Operation during Deceleration Monitoring and Constant-speed Monitoring

• Alarms

The operation when the motor speed exceeds the monitoring speed during deceleration monitoring and constant-speed monitoring is the same as the operation during deceleration monitoring of the SBB-D function. For details, refer to ■ *Operation during Deceleration Monitoring* in 6.4.1.

• Related Parameters

Parameters related to monitoring speed are described below.

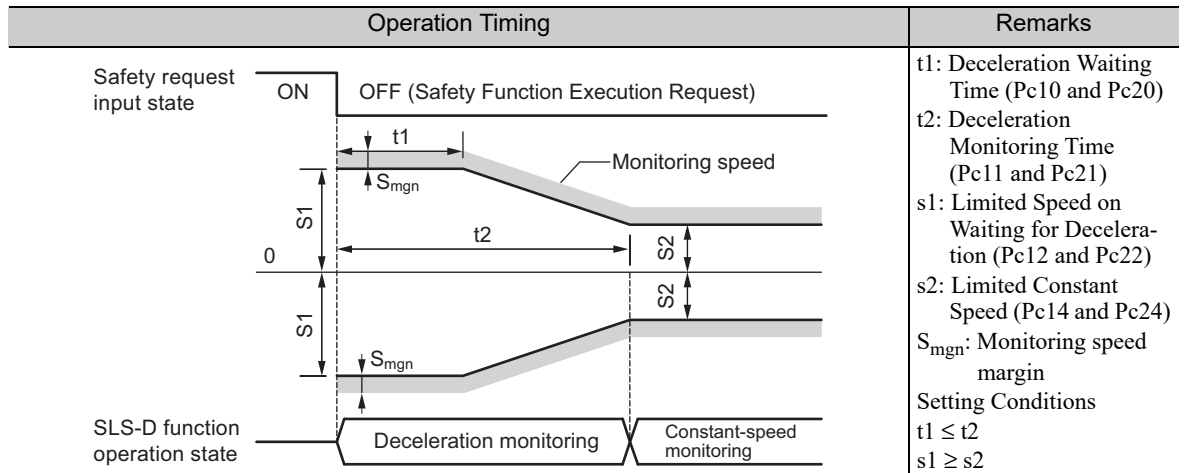

Parameter No.	Name	Setting Range	Units	Factory Setting	When Enabled
Pc10	Deceleration Waiting Time A (Safety Function A)	0 to 10000	10 ms	0	After resetting the system
Pc11	Deceleration Monitoring Time A (Safety Function A)	0 to 10000	10 ms	500	After resetting the system
Pc12	Limited Speed A on Waiting Deceleration (Safety Function A)	0 to 10000	Rotational motor: min^{-1} Linear motor: mm/s	0	After resetting the system
Pc14	Limited Constant Speed A (Safety Function A)	0 to 10000	Rotational motor: min^{-1} Linear motor: mm/s	0	After resetting the system
Pc20	Deceleration Waiting Time B (Safety Function B)	0 to 10000	10 ms	0	After resetting the system
Pc21	Deceleration Monitoring Time B (Safety Function B)	0 to 10000	10 ms	500	After resetting the system
Pc22	Limited Speed B on Waiting Deceleration (Safety Function B)	0 to 10000	Rotational motor: min^{-1} Linear motor: mm/s	0	After resetting the system
Pc24	Limited Constant Speed B (Safety Function B)	0 to 10000	Rotational motor: min^{-1} Linear motor: mm/s	0	After resetting the system

Note 1. The deceleration waiting time ($t1$) cannot be longer than the deceleration monitoring time ($t2$). If it is longer, alarm A.EB2 (Safety Module: Parameter Setting Error) will occur.

2. The limited constant speed ($s2$) cannot be faster than the deceleration waiting monitoring speed ($s1$). If it is faster, alarm A.EB2 (Safety Module: Parameter Setting Error) will occur.

3. Information on the Monitoring Speed Margin (S_{mgn})

A monitoring speed margin (S_{mgn}) that takes into account the speed detection accuracy is added to the monitoring speed during deceleration monitoring and during constant speed monitoring.

For the value of the monitoring speed margin, refer to 5.3.1 *Limitations on Lower Limit of Encoder Output Pulses*.

For a Safety Module with software version 0004 or higher, the monitoring speed margin during constant speed monitoring can be set to 0.

Operation when Pc00.3 = 1 (Monitoring speed margin is not applied during constant speed monitoring)

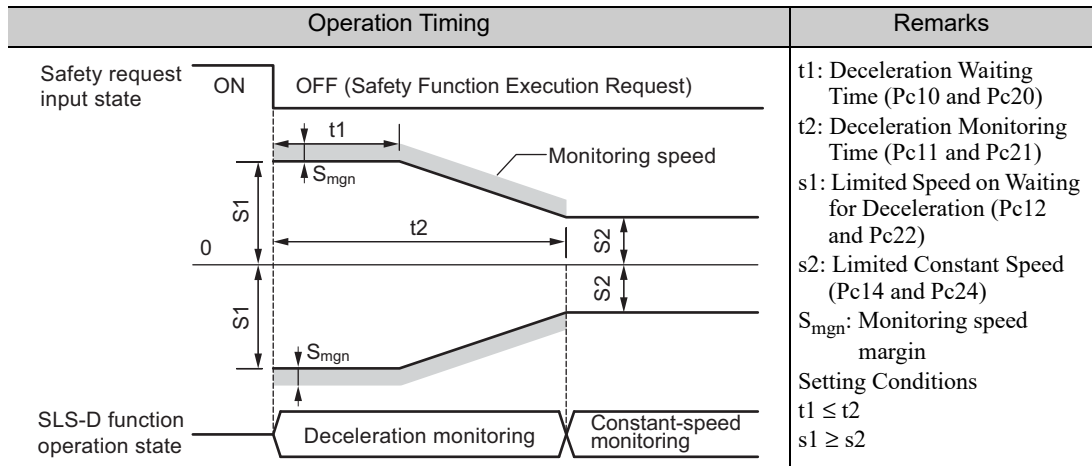

6.6.2 Settings

To use the SLS-D function, make the settings for using the SLS-D function of either Safety Function A or Safety Function B in the parameters. For details on the settings of the safety functions, refer to 6.2.1 *Selecting a Safety Function*.

6.6.3 Returning Method

The method of returning to normal operation depends on the operation state of the SLS-D function.

(1) During Deceleration Monitoring or Constant-speed Monitoring

The SERVOPACK will return to normal operation when the input state of safety request is turned to ON.

(2) During Safe (HWBB) State

The method of returning after an alarm has occurred and the SERVOPACK has changed to the safe (HWBB) state is the same as that for the SBB function. For details, refer to 6.3.3 *Returning Method*.

6.6.4 Exceptional Operation

(1) After Resetting the System

After the system is reset, if the Safety Request Input Signal turns OFF (Safety Function Execution Request) when the S-RDY signal turns OFF, the Safety Module performs constant-speed monitoring instead of deceleration monitoring.

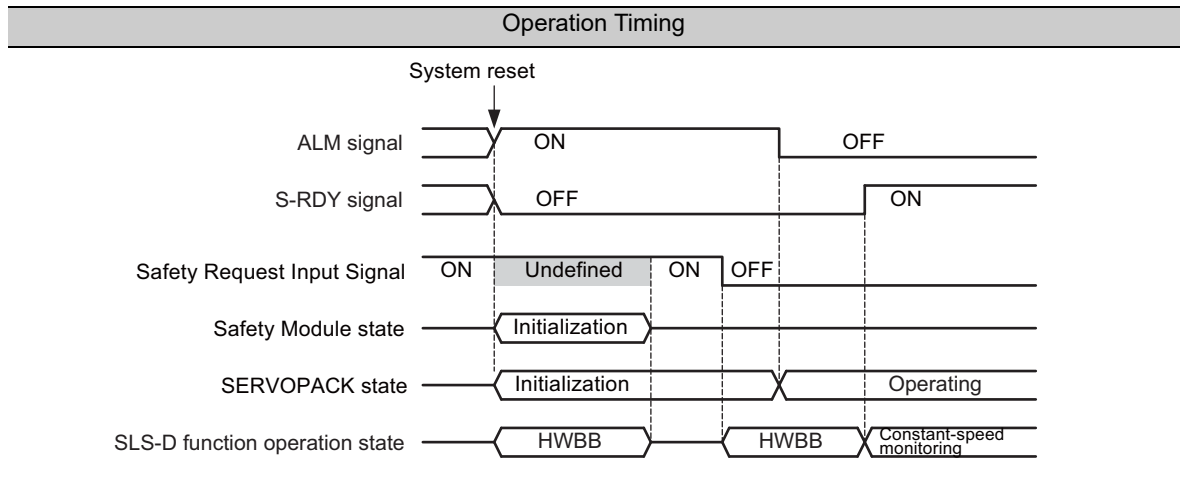

(2) While Recalculating Parameters

Similar to the CONFIG command of MECHATROLINK-II/-III/-4 communications or MECHATROLINK-III communications, if the Safety Request Input Signal turns OFF (Safety Function Execution Request) when the S-RDY signal turns OFF during recalculation, constant-speed monitoring is performed instead of deceleration monitoring.

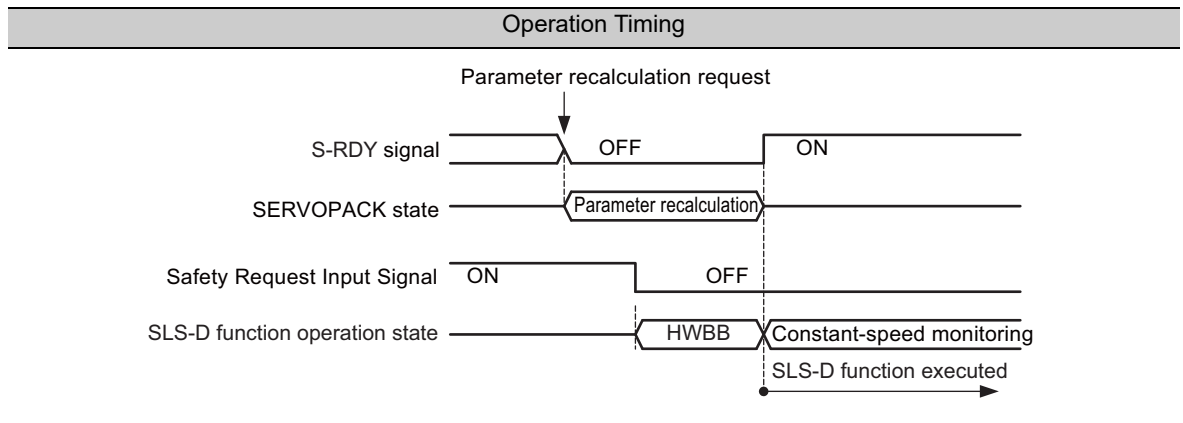

6.6.5 Related SERVOPACK Functions

The SERVOPACK functions and operations related to the operation of the SLS-D function are same as that for the SBB-D function. These are listed below. For details, refer to 6.4.5 *Related SERVOPACK Functions*.

- Always servo ON setting
- Motor stop mode
- Zero-speed stopping
- Overtravel
- Servo ready signal
- Brake sequence
- Relationship with MECHATROLINK-II commands
- Relationship with MECHATROLINK-III commands
- Relationship with MECHATROLINK-4 commands
- Utility functions
- SEN signal, encoder power supply OFF (SENS_OFF), sensor OFF (SENS_OFF)

6.7 Order of Priority of Safety Functions

Safety functions can be set individually for Safety Function A and Safety Function B. Two safety functions may be executed under the following two conditions:

- If one of the two safety functions is changed to the safe (HWBB) state, the other function will also be changed to the safe (HWBB) state.
- Both safety functions operate independently.

Examples of these two conditions are given below.

(1) When Both Safety Functions are Changed to the Safe (HWBB) State

During the execution of two safety functions, if one safety function is changed to the safe (HWBB) state, the other will also be forcibly changed to the safe (HWBB) state.

Example: When the SBB function is set as Safety Function A and the SPM-D function is set as Safety Function B

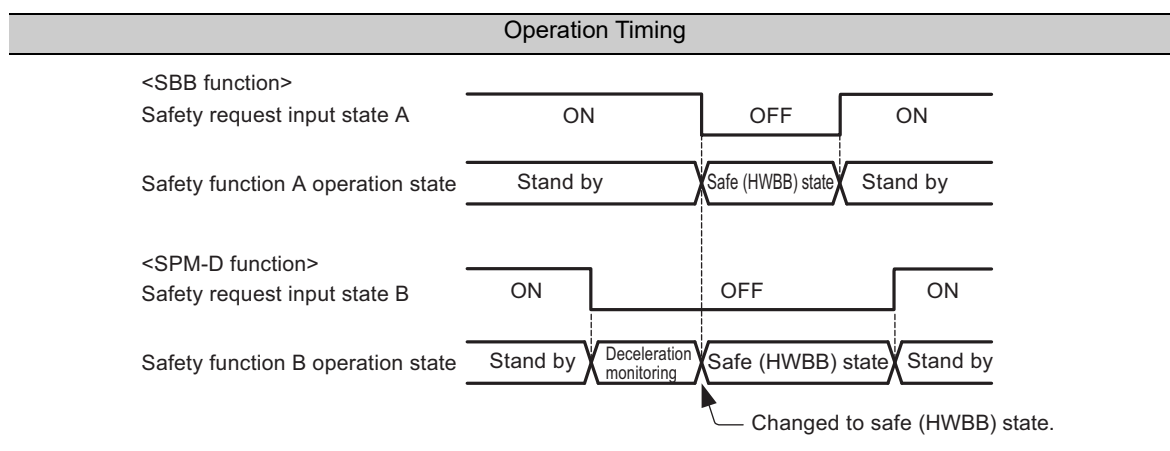

The returning method is the same as that for the SBB function. For details, refer to 6.3.3 *Returning Method*.

(2) When Two Safety Functions Operate Independently

Safety Function A and Safety Function B independently monitor the motor speed.

Example: When the SLS-D Function is set as Safety Function A and Safety Function B

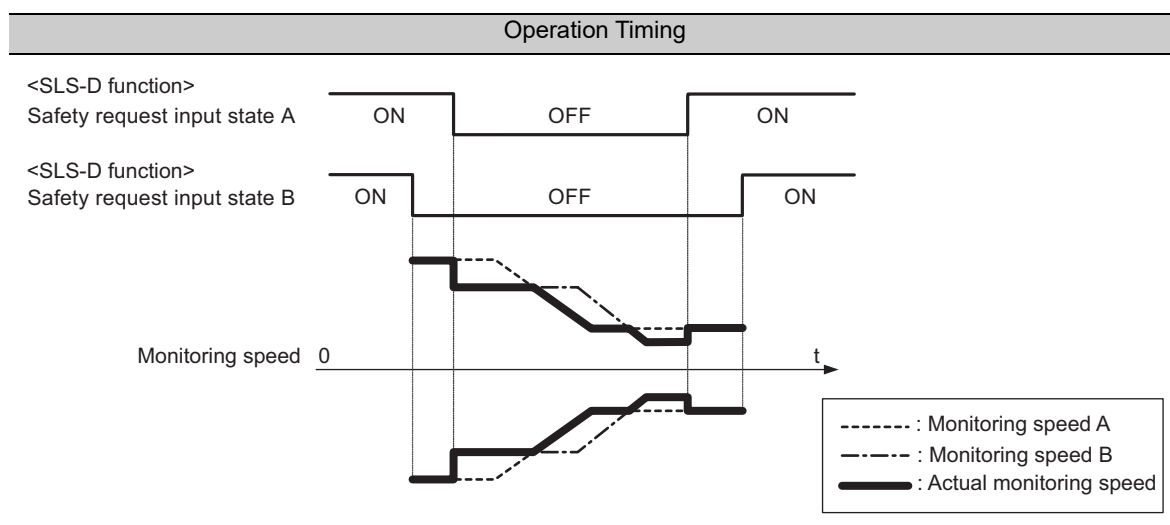

■ Reference Position When the SPM-D Function Is Set for Both Safety Functions

When the SPM-D function is set for Safety Function A and Safety Function B, the motor position set in the safety function that is the first to reach the position monitoring state is treated as the reference position of Safety Function A and Safety Function B.

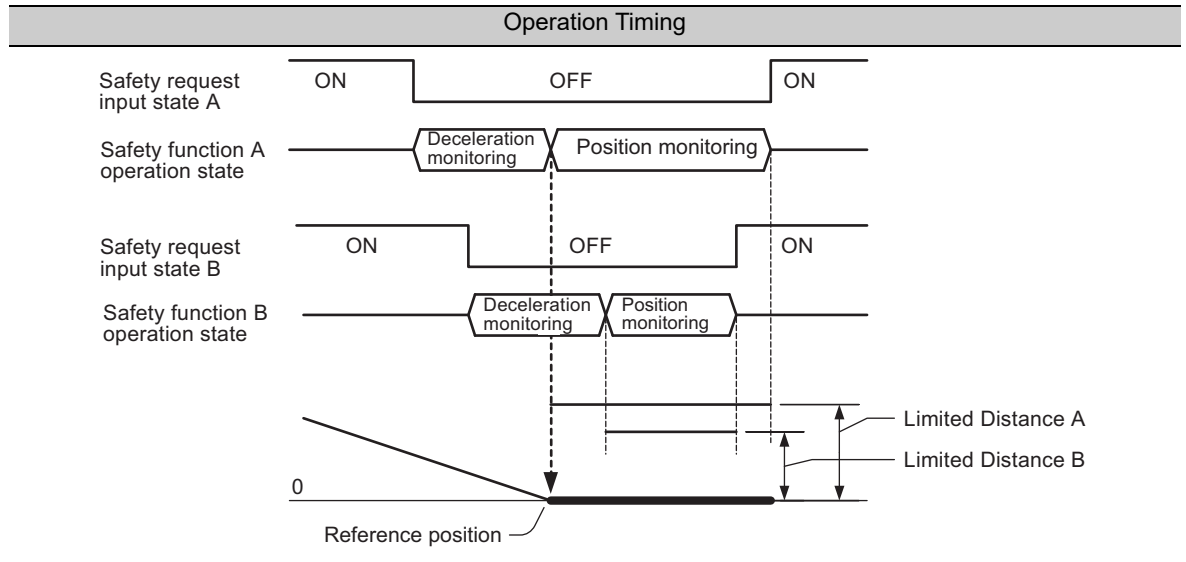

6.8 Application Example of Safety Functions

An application example of the safety functions is described below.

(1) Connection Example

A connection example in which a Safety Module is used and the safety functions are set to operate under the following conditions is described here.

- Safety Function A: Safety Function A (SLS-D function) operates when the door switch opens.
- Safety Function B: Safety Function B (SBB-D function) operates when the emergency stop switch is pressed.

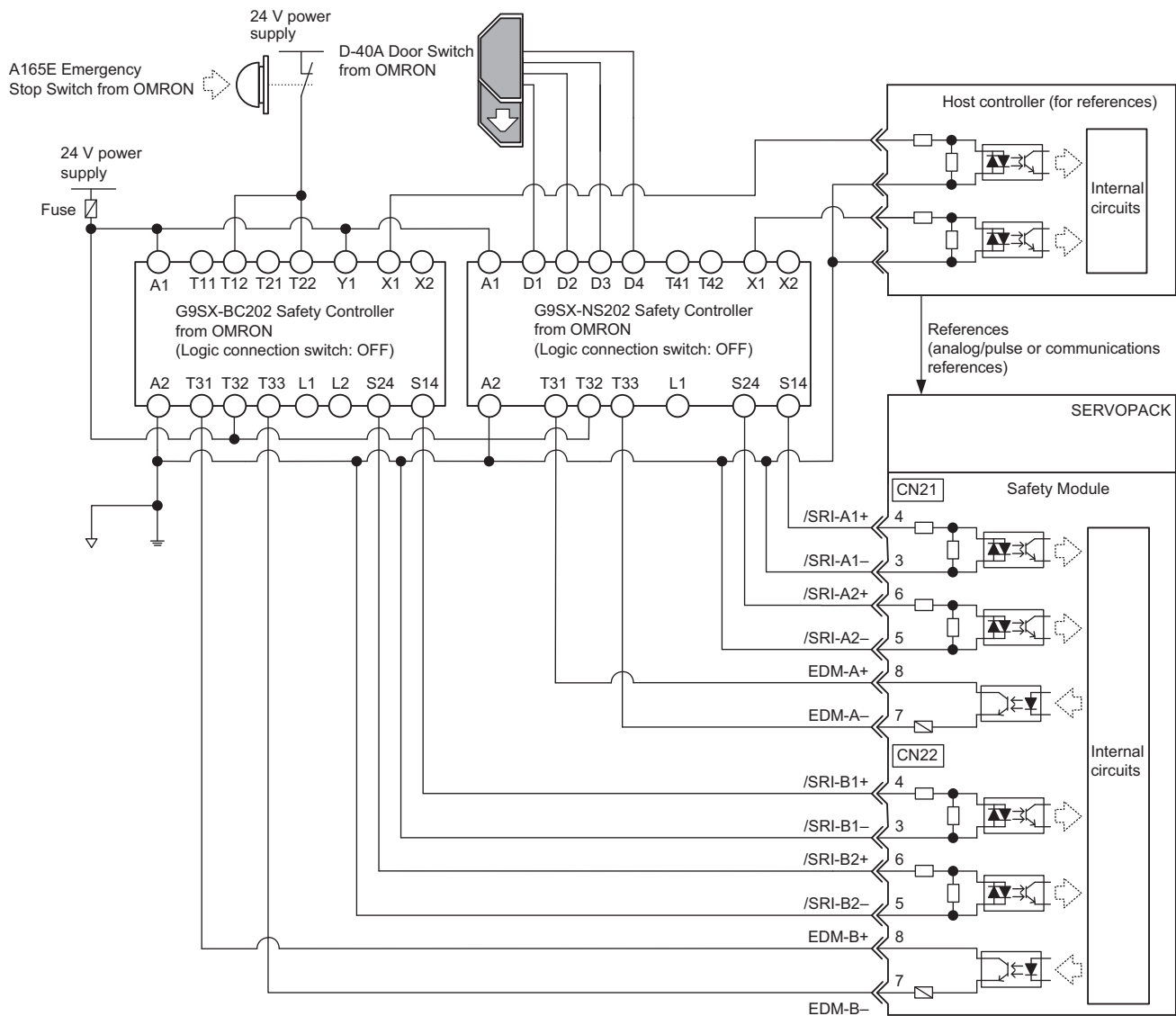

Note 1. For details on how to use OMRON products, contact an OMRON representative.

2. Use signals EDM-A and EDM-B as sourcing outputs. Make connections so that the electric current flows from EDM-A+ to EDM-A- or EDM-B+ to EDM-B-.

(2) Operation Example

■ Safety Function A

<When Door Switch Is Closed>

The X1 signal of the Safety Controller is OFF and the S14 and the S24 signals are ON. Signals /SRI-A1 and /SRI-A2 both are ON and Safety Function A (SLS-D function) does not operate. Normal operation is executed.

<When Door Switch Is Opened>

The X1 signal of the Safety Controller turns ON and the S14 and the S24 signals turn OFF. Due to the state of the X1 signal, the host controller switches from the normal operation reference to a deceleration reference toward the speed limit. The Safety Module monitors the speed. If the speed is within the specified Limited Constant Speed (Pc14) after the specified Deceleration Monitoring Time (Pc11) has elapsed, the EDM-A signal turns ON.

<When the Door Switch Closes after Opening>

If the speed is within the speed limit, the EDM-A signal remains ON. If the door switch is closed in this state, the X1 signal turns OFF and the S14 and the S24 signals turn ON because the Safety Controller is in the Auto Reset state. Due to the state of the X1 signal, the host controller switches from the speed limit operation reference to the normal operation reference, and normal operation is returned.

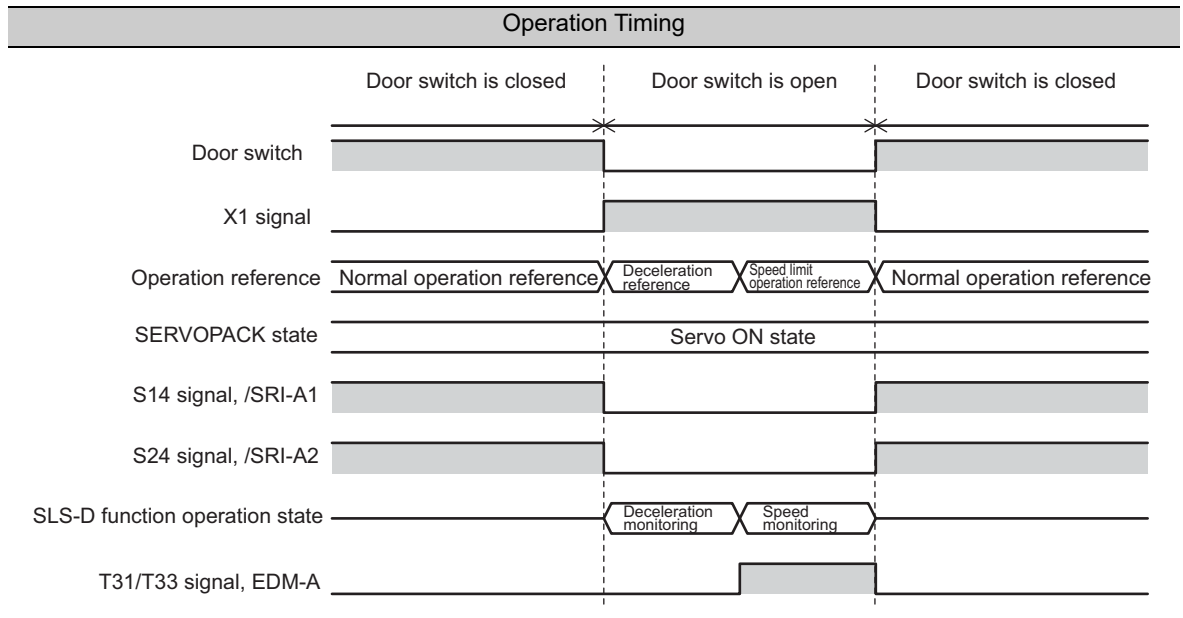

■ Safety Function B

<When the Emergency Stop Switch Is Not Pressed>

The X1 signal of the Safety Controller is OFF and the S14 and the S24 signals are ON. Signals /SRI-B1 and /SRI-B2 are both ON and Safety Function B (SBB-D function) does not operate. Normal operation is executed.

<When the Emergency Stop Switch Is Pressed>

The X1 signal of the Safety Controller turns ON and the S14 and the S24 signals turn OFF. Due to the state of the X1 signal, the host controller switches from the normal operation reference to the deceleration reference to stop. The motor is stopped and the servo is turned OFF. The Safety Module monitors the speed, and shuts OFF the power supply to the motor after the specified Deceleration Monitoring Time (Pc21) has elapsed. EDM-B turns ON when the power supply is shut OFF.

<When the Emergency Stop Switch Is Released>

The EDM-B signal is ON while no power is being supplied to the motor. If the emergency stop switch is released in this state, the X1 signal turns OFF and the S14 and the S24 signals turn ON because the Safety Controller is in the Auto Reset state. Due to the state of the X1 signal, the host controller switches to the normal operation reference, and normal operation is returned.

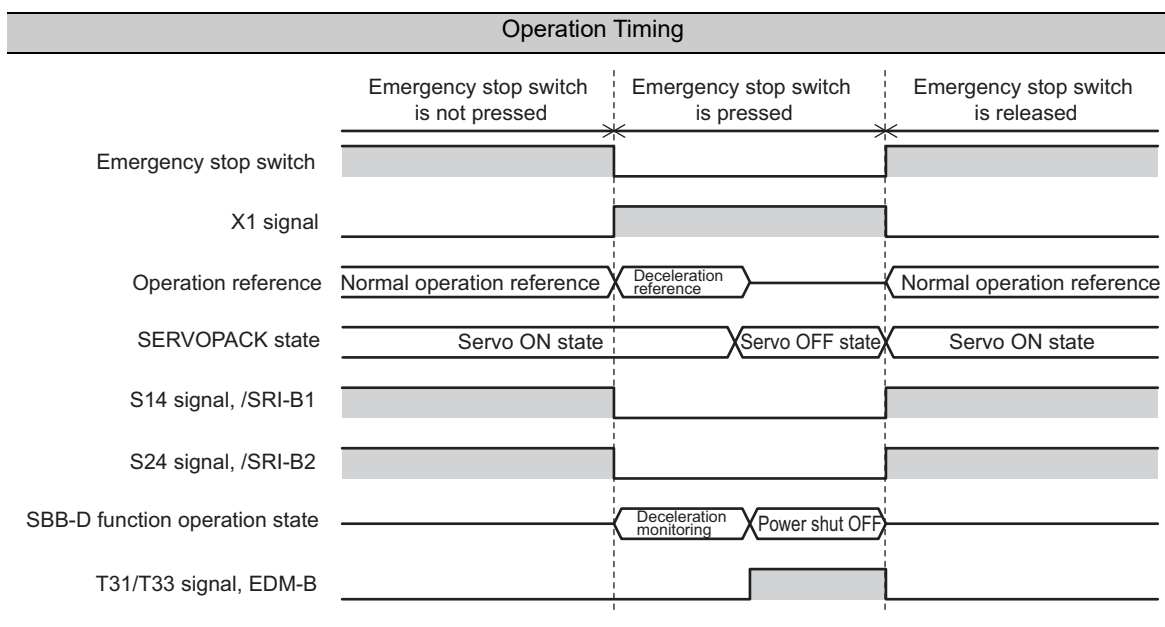

(3) Checking the Operation of Safety Functions

When starting the system or replacing a SERVOPACK or a Safety Module for maintenance or inspection purposes, you must perform the validation test described in 6.2.5 *Validating Safety Functions*.

Setting Parameters

This chapter describes the parameters related to the safety functions of the Safety Module.
For the parameters of the SERVOPACK, refer to the manual for your SERVOPACK.

7.1	Types of Parameters	7-2
7.2	Safety-related Module Parameters	7-3
7.2.1	Overview	7-3
7.2.2	Operation Procedures	7-4
7.3	Safety-related Servo Parameters	7-7
7.3.1	Overview	7-7
7.3.2	Operation Procedures	7-8

7.1 Types of Parameters

To operate the Safety Module, the parameters must be set according to the servo system being used. There are two types of Safety Module parameters, as described in the following table.

Parameters	Overview
Safety-related Module Parameters	These parameters are used to set safety functions. These parameters are used only for the Safety Module.
Safety-related Servo Parameters	These parameters contain information about the safety functions of the SERVOPACK and servomotor and are managed by the Safety Module. This information is maintained in the SERVOPACK, but it is also managed in the Safety Module with different parameter numbers. These parameters can be changed only from the SERVOPACK.

7.2 Safety-related Module Parameters

7.2.1 Overview

The safety-related module parameters are used to set the safety functions of the Safety Module. The safety-related module parameters are listed in the following table.

Parameter No.	Name
Pc00	Safety Function Selection Switch
Pc01	EDM Signal Output Selection Switch
Pc10	Deceleration Waiting Time A
Pc11	Deceleration Monitoring Time A
Pc12	Limited Speed A on Waiting for Deceleration
Pc13	Limited Distance A
Pc14	Limited Constant Speed A
Pc20	Deceleration Waiting Time B
Pc21	Deceleration Monitoring Time B
Pc22	Limited Speed B on Waiting for Deceleration
Pc23	Limited Distance B
Pc24	Limited Constant Speed B

7.2.2 Operation Procedures

The procedures for referencing, editing, and initializing the safety-related module parameters are given in this section.

(1) Referencing Parameters

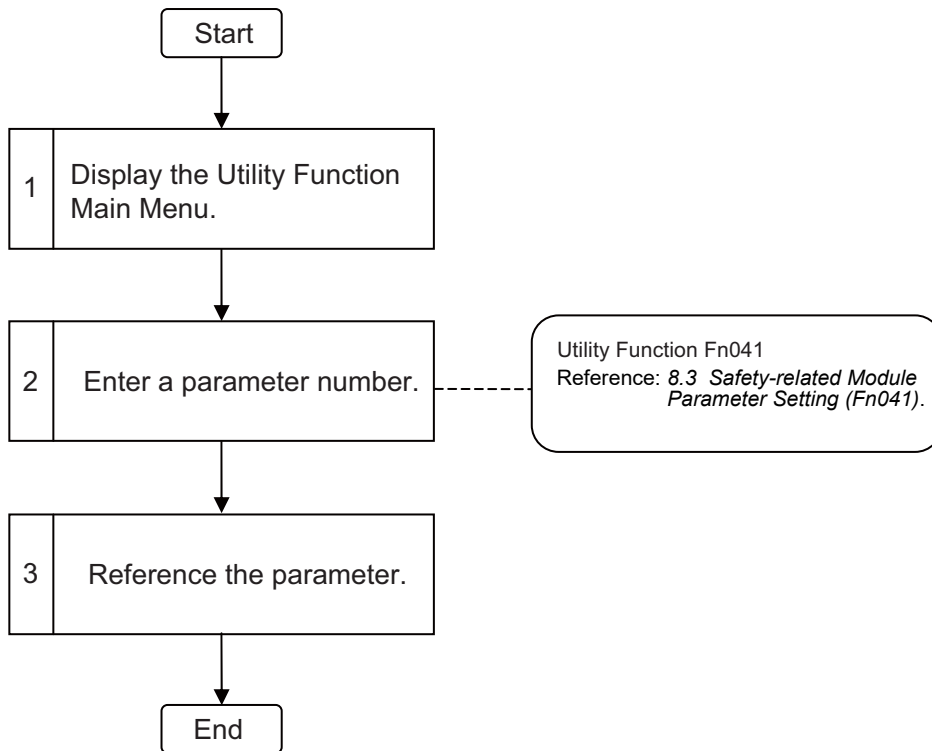

(2) Editing Parameters

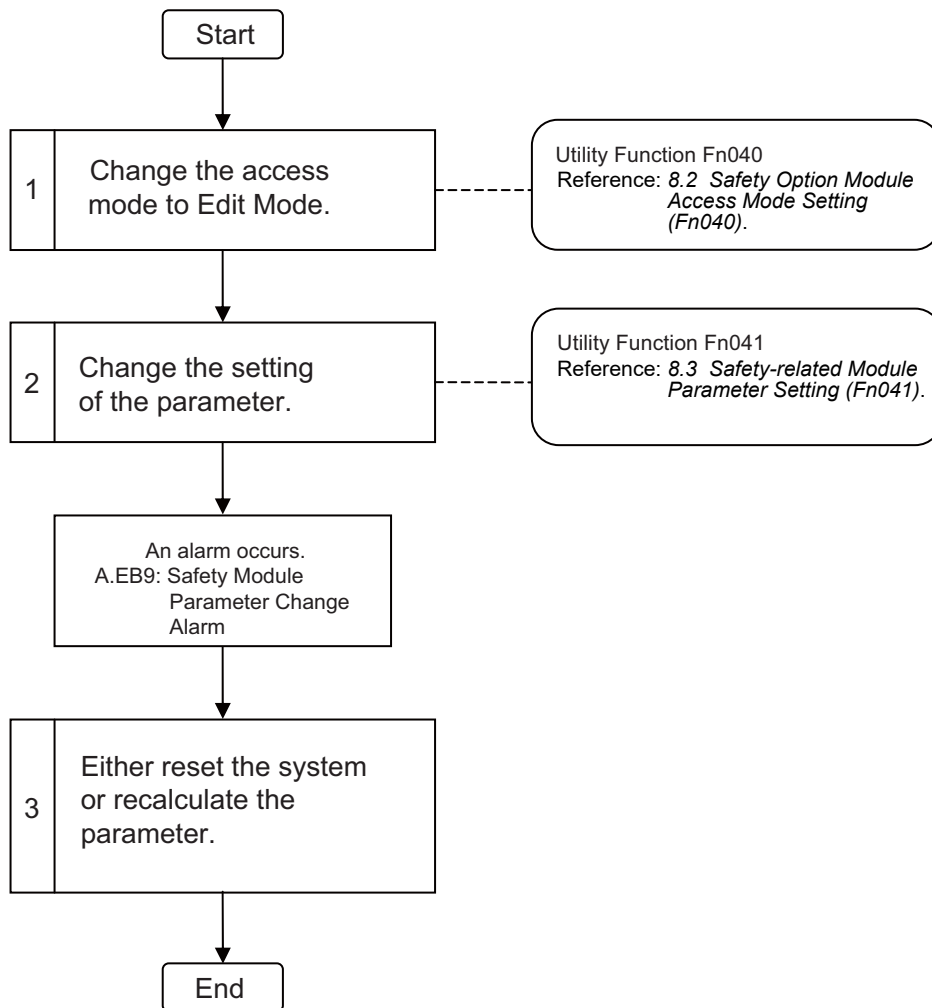

(3) Initializing Parameters

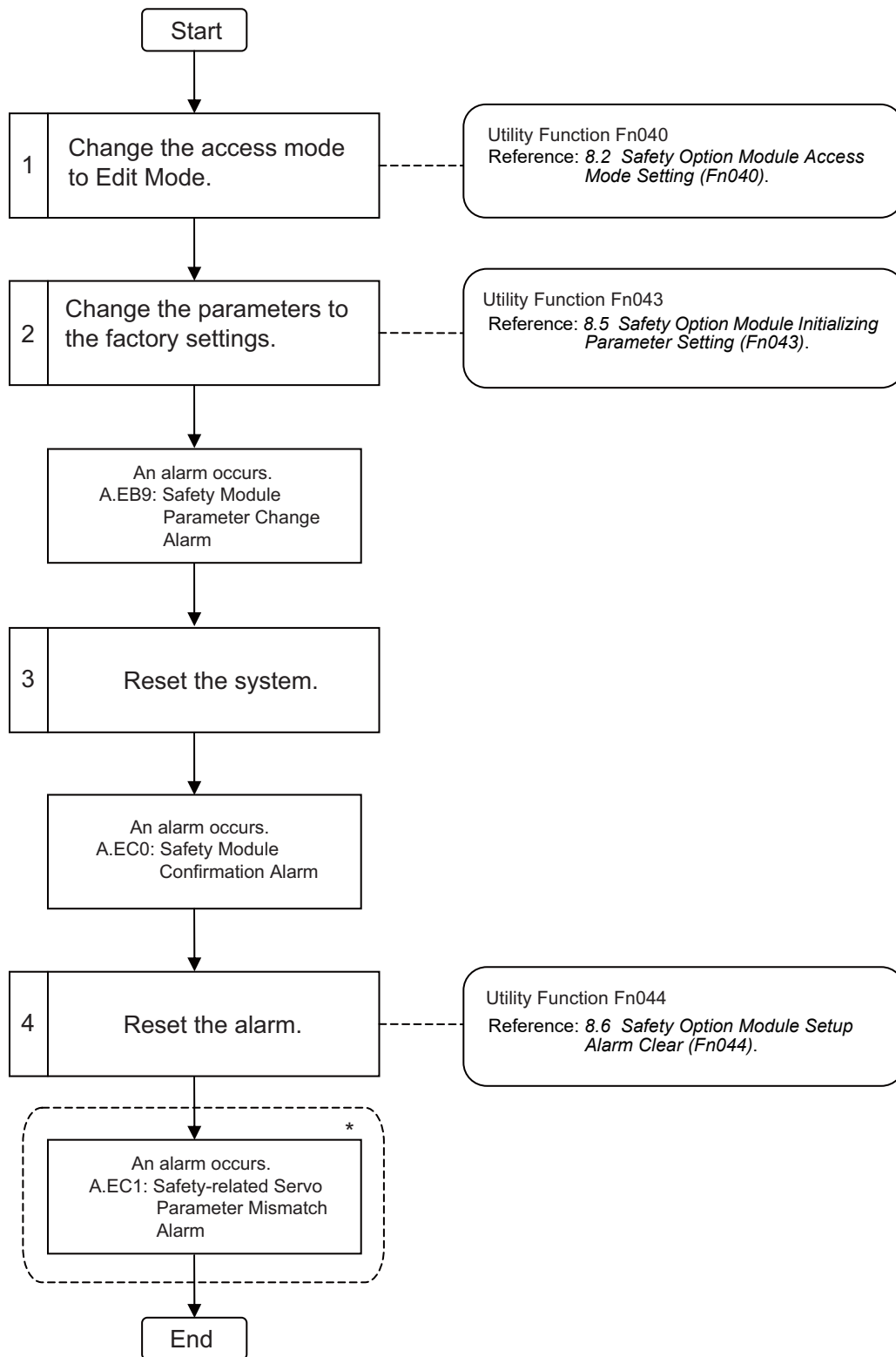

* This alarm occurs when the settings of a safety-related servo parameter and the corresponding parameter in the SERVOPACK do not match. When this alarm occurs, refer to step 4 of 7.3.2 (2) *Updating Parameters*.

7.3 Safety-related Servo Parameters

7.3.1 Overview

Safety-related servo parameters contain information about the safety functions of the SERVOPACK and servomotor and are managed by the Safety Module. This information is maintained in the SERVOPACK, but it is also managed in the Safety Module with different parameter numbers. To change a safety-related servo parameter, change the corresponding SERVOPACK parameter, and then update the parameters with the utility function Fn042.

The following table shows the correspondence between the safety-related servo parameters maintained in the Safety Module and the corresponding SERVOPACK parameters.

Safety-related servo parameter		SERVOPACK parameter			
Parameter No.	Name	Parameter No.	Name	Rotational Servomotor	Linear Servomotor
Pc50.0	Motor Type Setting	–	–	–	–
Pc51.0	Selection of Test without Motor	Pn00C.0	Test without Motor Function Setting	Applicable	Applicable
Pc5A.0	External Encoder Setting	Pn002.3	External Encoder Usage	Applicable	–
Pc60	Encoder Resolution	–	–	Applicable	–
Pc61	Divided Encoder Pulse	Pn212	Encoder Output Pulses	Applicable	–
	Encoder Output Resolution	Pn281	Encoder Output Resolution	–	Applicable
Pc62	Motor Max. Speed	Pn385	Motor Max. Speed	–	Applicable
Pc63	Linear Scale Pitch	Pn282	Linear Scale Pitch	–	Applicable

7.3.2 Operation Procedures

The procedures for referencing and updating the safety-related servo parameters are given in this section. The safety-related servo parameters cannot be edited.

(1) Referencing Parameters

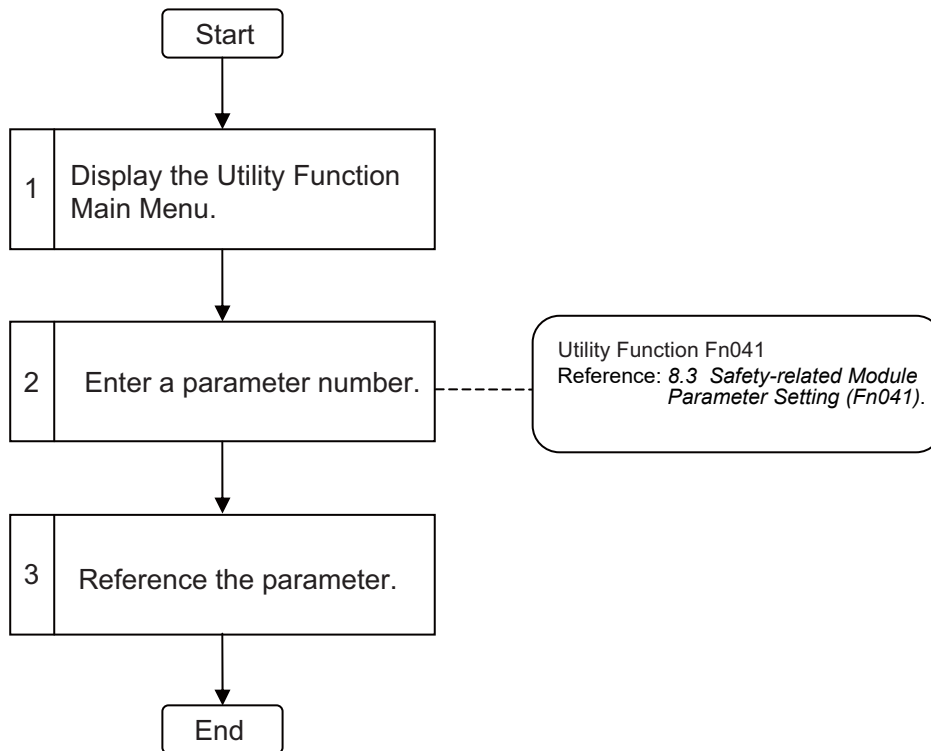

(2) Updating Parameters

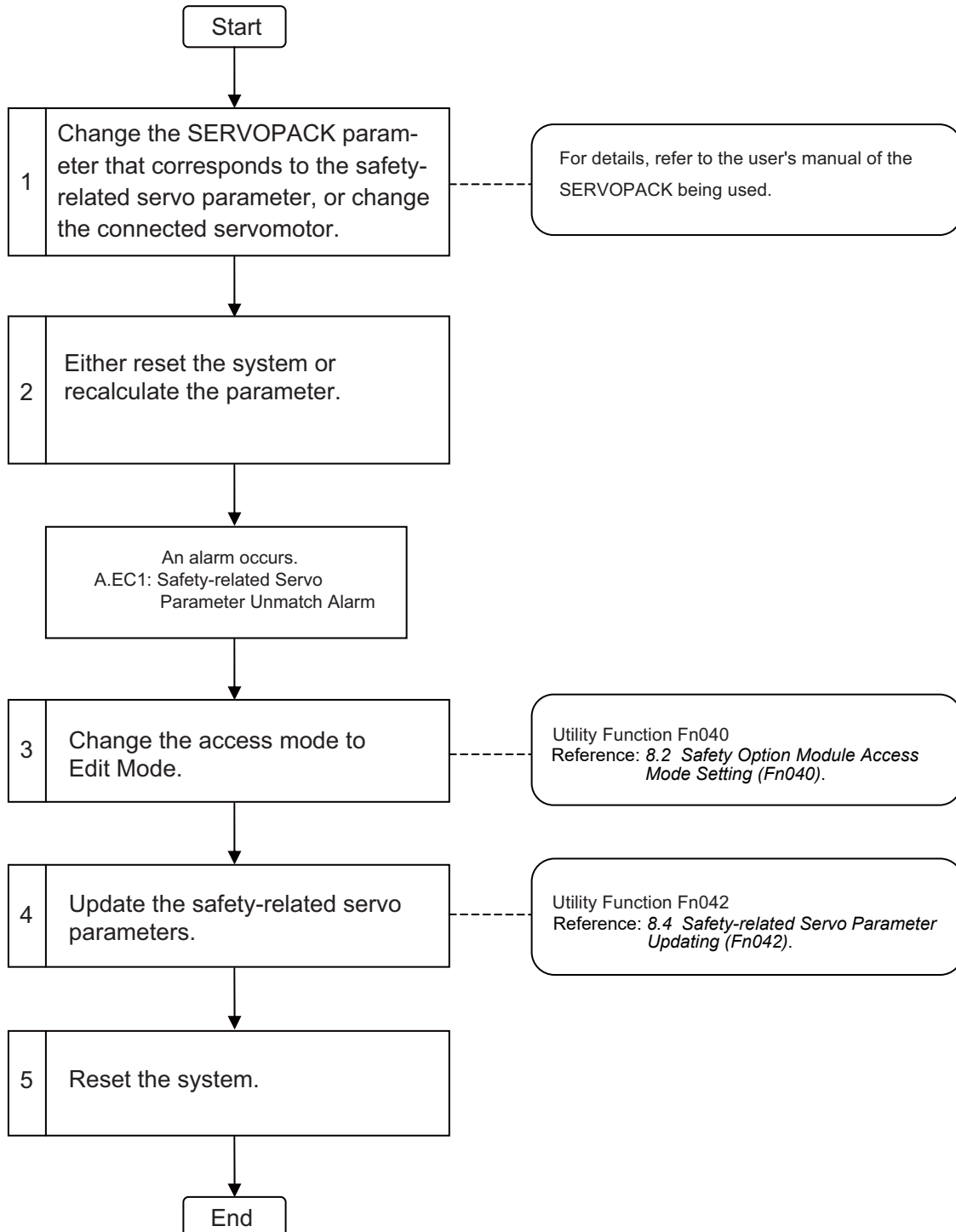

Utility Functions

This chapter describes the utility functions related to the Safety Module. For details on the utility functions of the SERVOPACK, refer to the manual for your SERVOPACK.

8.1 List of Utility Functions	8-2
8.2 Safety Option Module Access Mode Setting (Fn040)	8-3
8.2.1 Overview	8-3
8.2.2 Operation Procedures	8-3
8.3 Safety-related Module Parameter Setting (Fn041)	8-5
8.3.1 Overview	8-5
8.3.2 Operation Procedures	8-6
8.4 Safety-related Servo Parameter Updating (Fn042)	8-8
8.4.1 Overview	8-8
8.4.2 Operation Procedures	8-8
8.5 Safety Option Module Initializing Parameter Setting (Fn043)	8-12
8.5.1 Overview	8-12
8.5.2 Operation Procedures	8-12
8.6 Safety Option Module Setup Alarm Clear (Fn044)	8-14
8.6.1 Overview	8-14
8.6.2 Operation Procedures	8-15
8.7 Related Utility Functions	8-17
8.7.1 Software Version Display (Fn012)	8-17
8.7.2 Resetting Configuration Error in Option Modules (Fn014)	8-17
8.7.3 Display of SERVOPACK and Servomotor ID (Fn01E)	8-17

8.1 List of Utility Functions

When the Safety Module is connected to the SERVOPACK, the following utility functions can be used. These functions are used when operating the parameters of the safety Module and referring the informations related to the Safety Module.

Function No.	Function	Reference
Fn012	Software Version Display	8.7.1
Fn014	Resetting Configuration Error in Option Modules	8.7.2
Fn01E	Display of SERVOPACK and Servomotor ID	8.7.3
Fn040	Safety Option Module Access Mode Setting	8.2
Fn041	Safety-related Module Parameter Setting	8.3
Fn042	Safety-related Servo Parameter Updating	8.4
Fn043	Safety Option Module Initializing Parameter Setting	8.5
Fn044	Safety Option Module Setup Alarm Clear	8.6

8.2 Safety Option Module Access Mode Setting (Fn040)

8.2.1 Overview

To change the parameters of the Safety Module, the access mode must be changed to Edit Mode. The access mode can be switched using this function.

■ Preparation

























Before setting the Safety Module access mode, check the following:

- Alarm A.EB0 (Safety Module: System Malfunction) has not occurred.
- Alarm A.C90 (Encoder Communications Error) has not occurred.
- Alarm A.C91 (Encoder Communications Position Data Error) has not occurred.
- Alarm A.C92 (Encoder Communications Timer Error) has not occurred.

8.2.2 Operation Procedures

(1) Operating from the Digital Operator

The procedure for operating from the digital operator is shown below.

Step	Display After Operation	Keys	Operation
1	<pre> BB - FUNCTION - Fn030 Soft Reset Fn040 SOM ModeSet Fn041 SOM PrmEdit Fn042 SOM PrmUpd </pre>	  	Press the  Key to display the main menu of utility function mode and select Fn040 using the  or  Key.
2	<pre> BB Safety Access Mode Set P.0001 </pre>		Press the  Key. The display switches to the Fn040 main window.
3	<pre> BB Safety Access Mode Set P.000<u>0</u> </pre>	    	Press the  ,  , and  ,  Keys to change “P.0001” (reference screen) to “P.0000” (edit screen). Note: Press the  Key to return to the main menu of utility function mode.
4	<pre> BB Safety Access Mode Set P.0000 </pre> <p>Status display</p>	 	Press the  Key to save the set value. When the set value has been saved, “DONE” flashes in the status display for approx. one second. Note: <ul style="list-style-type: none"> • If an attempt to save the set value fails: “ERROR” flashes in the status display for approx. one second and the display returns to step 3. Try to save the set value again. • If alarm A.EB0 (Safety Module: System Malfunction) occurs: “NO-OP” is displayed in the status display and “SYSTEM ERROR” flashes on the screen. Press the  Key to return to the main menu of utility function mode. Try to make the settings again.
5	<pre> BB - FUNCTION - Fn030 Soft Reset Fn040 SOM ModeSet Fn041 SOM PrmEdit Fn042 SOM PrmUpd </pre>		Press the  Key to return to the main menu of utility function mode.

(2) Operating from the Panel Operator

The procedure for operating from the panel operator is shown below.

Step	Display After Operation	Keys	Operation
1			Press the MODE/SET Key to select the utility function mode.
2			Press the UP or DOWN Key to display “Fn040.”
3			Press the DATA/SHIFT Key for at least one second to display “P.0001.” Note: If an error occurs: “no-oP” flashes for approx. one second, after which “Fn040” is displayed again.
4			Press the DOWN Key to display “P.0000.” Note: If the DATA/SHIFT Key is pressed for at least one second, “Fn040” is displayed again.
5			Press the MODE/SET Key to save the set value. When the set value has been saved, “donE” flashes for approx. one second and then “P.0000” is displayed again. Note: <ul style="list-style-type: none"> • If an attempt to save the set value fails: “Error” flashes for approx. one second and then “P.0000” is displayed again. Try to save the set value again. • If an error occurs: “no-oP” flashes for approx. one second, and “P.0000” is displayed again.
6			Press the DATA/SHIFT Key for at least one second to return to the utility function selection screen.

Note: If the following events occur while the access mode is being changed, the utility function is ended forcibly before the results are confirmed, and the status is displayed in the panel. If this occurs, execute the utility function again.

- If an alarm occurs while the utility function is being executed from the panel operator
- If a digital operator is connected to the SERVOPACK

8.3 Safety-related Module Parameter Setting (Fn041)

8.3.1 Overview

This function is used to change the safety-related module parameters.

■ Preparation

Before setting the safety-related module parameters check the following:

- The servo must be OFF.
- Alarm A.EB0 (Safety Module: System Malfunction) has not occurred.
- Alarm A.C90 (Encoder Communications Error) has not occurred.
- Alarm A.C91 (Encoder Communications Position Data Error) has not occurred.
- Alarm A.C92 (Encoder Communications Timer Error) has not occurred.
- When the parameters of the Safety Module are changed, the Safety Option Module Access Mode Setting (Fn040) must be set to “P.0000.”

■ Related Alarms



































The following alarms are related to this function. For details on the alarms, refer to Chapter 11 Troubleshooting.

No.	Name	Description	Alarm Reset	Stop Mode
A.EB9	Safety Module: Parameter Change Alarm	A Safety Module parameter for which the power must be turned OFF and then ON again to enable the settings was changed.	Available	According to the setting of Pn001.0

8.3.2 Operation Procedures

(1) Operating from the Digital Operator

The procedure for operating from the digital operator is shown below.

Step	Display After Operation	Keys	Operation
1	<pre> BB - FUNCTION - Fn040 SOM ModeSet Fn041 SOM PrmEdit Fn042 SOM PrmUpd Fn043 SOM PrmInit </pre>	  	Press the  Key to display the main menu of utility function mode and select Fn041 using the  or  Key.
2	<pre> BB - R/W - Safety Parameter Edit Pc00=n.0000 </pre>		Press the  Key. The display switches to the Fn041 main window.
3	<pre> BB - R/W - Safety Parameter Edit Pc10=00000 </pre>	    	Press the  ,  and  ,  Keys to set the parameter number of the safety-related module parameter. The parameter value appears automatically. Note: Press the  Key to return to the main menu of utility function mode.
4	<p>Status display</p> <pre> BB - R/W - Safety Parameter Edit Pc10=0000<u>0</u> </pre>		Press the  Key. The cursor moves from “Pc10” to “00000.” Note: If the “P.0000” (edit screen) has not been set with the Safety Option Module Access Mode Setting (Fn040): “NO-OP” flashes in the status display for approx. one second and the display returns to step 3. Set the “P.0000” (edit screen) with Fn040.
5	<pre> BB - R/W - Safety Parameter Edit Pc10=000<u>2</u>0 </pre>	    	Press the  ,  and  ,  Keys to change the parameter value. Note: Press the  Key to return to step 3.
6	<pre> BB - R/W - Safety Parameter Edit Pc10=000<u>2</u>0 </pre>		Press the  Key to save the set value. When the set value has been saved, “DONE” flashes in the status display for approx. one second. Note: If an attempt to save the set value fails: “Error” flashes for approx. one second in the status display and the display returns to step 5. Try to make the settings again.
7	<pre> BB - FUNCTION - Fn040 SOM ModeSet Fn041 SOM PrmEdit Fn042 SOM PrmUpd Fn043 SOM PrmInit </pre>		Press the  Key to return to the main menu of utility function mode.

Note: If alarm A.EB0 (Safety Module: System Malfunction) occurs during operation, “NO-OP” is displayed in the status display and “SYSTEM ERROR” flashes on the screen. Press the  Key to return to the main menu of utility function mode, and make the settings again.

(2) Operating from the Panel Operator

The procedure for operating from the panel operator is shown below.

Step	Display After Operation	Keys	Operation
1			Press the MODE/SET Key to select the utility function mode.
2			Press the UP or DOWN Key to display “Fn041.”
3			Press the DATA/SHIFT Key for at least one second to display the parameter number selection screen.
4			Press the DATA/SHIFT Key, and UP or DOWN Key to set the parameter number. Note: If the DATA/SHIFT Key is pressed for at least one second, the display returns to the parameter number selection screen.
5			Press the MODE/SET Key to display the set value of the selected parameter number.
6			Press the DATA/SHIFT Key, and UP or DOWN Key to set the parameter value. Note 1. When the “P.0000” (edit screen) has not been set with the Safety Module Access Mode Setting (Fn040): “no-oP” flashes for approx. one second. Set the “P.0000” (edit screen) with Fn040. 2. If the DATA/SHIFT Key is pressed for at least one second, the display returns to step 4.
7			Press the MODE/SET Key to save the set value. When the set value has been saved, “donE” flashes for approx. one second and the parameter value is displayed. Note 1. When the “P.0000” (edit screen) has not been set with the Safety Module Access Mode Setting (Fn040): “no-oP” flashes for approx. one second. Set the “P.0000” (edit screen) with Fn040. 2. If an attempt to save the set value fails: “Error” flashes for approx. one second, and the display returns to step 6. Try to make the settings again.
8			Press the DATA/SHIFT Key for at least one second to return to the utility function selection screen.

Note: If the following events occur while a parameter is being edited, the utility function is ended forcibly before the results are confirmed, and the status is displayed in the panel. If this occurs, execute the utility function again.

- If an alarm occurs while the utility function is being executed from the panel operator
- If a digital operator is connected to the SERVOPACK

8.4 Safety-related Servo Parameter Updating (Fn042)

8.4.1 Overview

The settings of SERVOPACK parameters related to the safety functions are managed in the Safety Module. These parameters are called safety-related servo parameters.

This function is used to copy the settings of SERVOPACK parameters related to the safety functions to safety-related servo parameters maintained in the Safety Module.

■ Preparation

Before updating the safety-related servo parameters check the following:

- The servo must be OFF.
- Alarm A.EB0 (Safety Module: System Malfunction) has not occurred.
- Alarm A.C90 (Encoder Communications Error) has not occurred.
- Alarm A.C91 (Encoder Communications Position Data Error) has not occurred.
- Alarm A.C92 (Encoder Communications Timer Error) has not occurred.
- The Safety Option Module Access Mode Setting (Fn040) must be set to “P.0000.”

■ Related Alarms













The following alarms are related to this function. For details on the alarms, refer to Chapter 11 Troubleshooting.

No.	Name	Description	Alarm Reset	Stop Mode
A.EC1	Safety-related Servo Parameter Unmatch Alarm	The settings of a safety-related servo parameter and the corresponding SERVOPACK parameter related to the safety functions do not match.	Available	According to the setting of Pn001.0







8.4.2 Operation Procedures

(1) Operating from the Digital Operator

The procedure for operating from the digital operator is shown below.

Step	Display After Operation	Keys	Operation
1	<pre> BB - FUNCTION - Fn041 SOM PrmEdit Fn042 SOM PrmUpd Fn043 SOM PrmInit Fn044 SOM AlmClr </pre>	  	Press the  Key to display the main menu of utility function mode and select Fn042 using the  or  Key.
2	<p>Parameter Check Screen</p> <pre> BB - Prm Upd - PcXX 1/X <Func Select SW> Op = n.0000 SV = n.FFFF </pre> <p>Parameter Match Screen</p> <pre> DONE - Prm Upd - All Parameters Matched </pre>		Press the  Key. The safety-related servo parameters are compared with corresponding SERVOPACK parameters. <ul style="list-style-type: none"> • If parameter settings do not match: As many parameter check screens as the number of mismatching parameters are created, and the first parameter check screen is displayed. • If parameter settings match: The parameter match screen is displayed for approx. one second, and the display returns to the main menu of utility function mode.
3	<pre> BB - Prm Upd - PcXX 1/X <Func Select SW> Op = n.0000 SV = n.FFFF </pre>	 	Use the   Keys to switch between the parameter check screens. The settings of the parameters are displayed.

(cont'd)

Step	Display After Operation	Keys	Operation
4	<pre> BB - Prm Upd - PcXX 1/X <Func Select SW> Op =n.0000 SV =n.FFFF </pre>	 	<p>Press the  Key to update the safety-related servo parameter.</p> <p>When the parameter has been updated, “DONE” flashes in the status display for approx. one second, and the display returns to the parameter check screen. Repeat the operation in Step 3 to 4 and update all the mismatched parameters.</p> <p>Note:</p> <ul style="list-style-type: none"> • If an attempt to update the parameter fails: “ERROR” flashes in the status display for approx. one second, and the display returns to the parameter check screen. Try to update the parameter again. • If the “P.0000” (edit screen) has not been set with the Safety Option Module Access Mode Setting (Fn040): “NO-OP” flashes in the status display for approx. one second. Set the “P.0000” (edit screen) with Fn040. • When the safety-related servo parameter is not to be updated: Press the  Key to return to the main menu of utility function mode.
5	<pre> BB - FUNCTION - Fn041 SOM PrmEdit Fn042 SOM PrmUpd Fn043 SOM PrmInit Fn044 SOM AlmClr </pre>		<p>Press the  Key to return to the main menu of utility function mode.</p>

(2) Operating from the Panel Operator

The procedure for operating from the panel operator is shown below.

Step	Display After Operation	Keys	Operation
1			Press the MODE/SET Key to select the utility function mode.
2			Press the UP or DOWN Key to display “Fn042.”
3			Press the DATA/SHIFT Key for at least one second. The safety-related servo parameters are compared with corresponding SERVOPACK parameters. <ul style="list-style-type: none"> • If the parameter settings do not match: The number of the mismatched parameter is displayed. • If the parameter settings match: “donE” is displayed for approx. one second, and the display returns to the utility function selection screen.
4			Press the UP or DOWN Key to select the parameter number. Note: If the DATA/SHIFT Key is pressed for at least one second, the display returns to the utility function selection screen.
5	Safety Module SERVOPACK 		Press the MODE/SET Key to display a selection screen for selecting whether to display the parameter maintained in the Safety Module or a SERVOPACK parameter. Press the UP or DOWN Key to select either “O.oP” (safety-related servo parameter maintained in the Safety Module) or “I.Sv” (SERVOPACK parameter related to the safety functions). Note: If the DATA/SHIFT Key is pressed for at least one second when changing the parameter number, the display returns to step 4.
6			Press the MODE/SET Key to display the setting of the selected parameter. When the DATA/SHIFT Key is pressed, the display switches between the upper, middle, and lower digits of the parameter value. Note: If the DATA/SHIFT Key is pressed for at least one second, the display returns to step 5.
7			Press the MODE/SET Key to display the screen on the left. Note 1. When the “P.0000” (edit screen) has not been set with the Safety Module Access Mode Setting (Fn040): “no-oP” flashes for approx. one second. Set the “P.0000” (edit screen) with Fn040. 2. If the DATA/SHIFT Key is pressed for at least one second, the display returns to step 4.
8			Press the MODE/SET Key to update the parameter. “S-UPd” flashes while the parameter is being updated. When the parameter has been updated, “donE” flashes for approx. one second, and the value of the updated safety-related servo parameter is displayed. Note: If an attempt to update the parameter fails: “Error” flashes for approx. one second and the display returns to step 7. Try to update the parameter again.

(cont'd)

Step	Display After Operation	Keys	Operation
9	 or 		Press the DATA/SHIFT Key for at least one second to display the screen on the left.
10			Press the DATA/SHIFT Key for at least one second to display the screen on the left. Repeat the operation in Step 4 to 10 and update all the mismatched parameters.
11			Press the DATA/SHIFT Key for at least one second to return to the utility function selection screen.

Note: If the following events occur while a parameter is being edited, the utility function is ended forcibly before the results are confirmed, and the status is displayed in the panel. If this occurs, execute the utility function again.

- If an alarm occurs while the utility function is being executed from the panel operator
- If a digital operator is connected to the SERVOPACK

8.5 Safety Option Module Initializing Parameter Setting (Fn043)

8.5.1 Overview

This function initializes the parameters of the Safety Module to the factory settings. This function is used if the Safety Module parameters are to be initialized to the factory settings from the current settings, or if consistency of parameters cannot be achieved due to a memory error in the Safety Module.

■ Preparation

Before initializing the Safety Module parameters check the following:

- The servo must be OFF.
- Alarm A.C90 (Encoder Communications Error) has not occurred.
- Alarm A.C91 (Encoder Communications Position Data Error) has not occurred.
- Alarm A.C92 (Encoder Communications Timer Error) has not occurred.
- The Safety Option Module Access Mode Setting (Fn040) must be set to “P.0000.”

■ Related Alarms













The following alarms are related to this function. For details on the alarms, refer to Chapter 11 Troubleshooting.

No.	Name	Description	Alarm Reset	Stop Mode
A.EB9	Safety Module: Parameter Change Alarm	A Safety Module parameter for which the power must be turned OFF and then ON again to enable the settings was changed.	Available	According to the setting of Pn001.0
A.EC0	Safety Module: Confirmation Alarm	A SERVOPACK different from the one used before has been connected. Alternatively, the Safety Module parameters were initialized.	Available	According to the setting of Pn001.0



8.5.2 Operation Procedures

(1) Operating from the Digital Operator

The procedure for operating from the digital operator is shown below.

Step	Display After Operation	Keys	Operation
1	<pre> BB - FUNCTION - Fn042 SOM PrmUpd Fn043 SOM PrmInit Fn044 SOM AlmClr Fn080 Pole Detect </pre>	  	Press the  Key to display the main menu of utility function mode and select Fn043 using the  or  Key.
2	<pre> BB Safety Parameter Init Start :[DATA] Return:[SET] </pre>	 	Press the  Key to display the parameter initialization execution screen. Note: If the  Key is pressed, the display returns to the main menu of Utility Function Mode.
3	<pre> BB Safety Parameter Init Start :[DATA] Return:[SET] </pre>		Press the  Key to initialize the Safety Module parameters. During initialization, “Processing” flashes on menu display. When the parameters have been initialized, “DONE” flashes in the status display for approx. one second. Note: If an attempt to initialize the parameters fails: “ERROR” flashes in the status display for approx. one second, and the display returns to the parameter initialization execution screen. Try to initialize the parameters again.







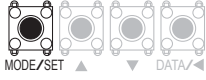

(cont'd)

Step	Display After Operation	Keys	Operation
4	<pre> BB - FUNCTION - Fn041 SOM PrmEdit Fn042 SOM PrmUpd Fn043 SOM PrmInit Fn044 SOM AlmClr </pre>		Press the  Key to return to the main menu of utility function mode.

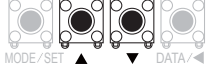
Note: If alarm A.EB0 (Safety Module: System Malfunction) occurs during operation, “NO-OP” is displayed in the status display and “SYSTEM ERROR” flashes on the screen. Press the  Key to return to the main menu of utility function mode, and make the settings again.

(2) Operating from the Panel Operator

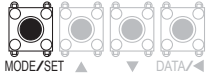
The procedure for operating from the panel operator is shown below.

Step	Display After Operation	Keys	Operation
1			Press the MODE/SET Key to select the utility function mode.
2			Press the UP or DOWN Key to display “Fn043.”
3			Press the DATA/SHIFT Key for at least one second to display “P.InIt.”
4			Press the MODE/SET Key to initialize the Safety Module parameters. During initialization, “P.InIt” flashes on the panel. When the parameters have been initialized, “donE” flashes for approx. one second, and then “P.InIt” is displayed again.
5			Press the DATA/SHIFT Key for at least one second to return to the utility function selection screen.

Note: If the following events occur while a parameter is being edited, the utility function is ended forcibly before the results are confirmed, and the status is displayed in the panel. If this occurs, execute the utility function again.

- If an alarm occurs while the utility function is being executed from the panel operator
- If a digital operator is connected to the SERVOPACK

8.6 Safety Option Module Setup Alarm Clear (Fn044)

8.6.1 Overview

This function clears the cause of the Safety Module: Confirmation Alarm (A.EC0).

This alarm occurs in the following cases:

- The system was reset or parameters were recalculated after the combination of the SERVOPACK and Safety Module was changed.
- The system was reset or parameters were recalculated after the Safety Module parameters were initialized.

Executing this function means that the user has confirmed that the SERVOPACK combination has been changed or Safety Module parameters has been initialized.

Note: The alarm display (A.EC0) is not cleared even if this function is executed. After executing this function, always reset the system.

■ Preparation















Before clearing the Safety Module Confirmation Alarm check the following:

- The servo must be OFF.
- Alarm A.C90 (Encoder Communications Error) has not occurred.
- Alarm A.C91 (Encoder Communications Position Data Error) has not occurred.
- Alarm A.C92 (Encoder Communications Timer Error) has not occurred.

8.6.2 Operation Procedures

(1) Operating from the Digital Operator







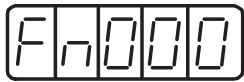
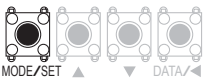

The procedure for operating from the digital operator is shown below.

Step	Display After Operation	Keys	Operation
1	<pre>A.EC0 -FUNCTION- Fn043 SOM PrmInit Fn044 SOM AlmClr Fn080 Pole Detect Fn200 TuneLvISet</pre>	  	Press the  Key to display the main menu of utility function mode and select Fn044 using the  or  Key.
2	<pre>A.EC0 Safety Setup Alarm Clr Start :[DATA] Return:[SET]</pre>	 	Press the  Key to display the setup alarm clear execution screen. Note 1. If the cause of the Safety Module: Confirmation Alarm (A.EC0) is cleared: “NO-OP” is displayed in the status display for approx. one second. 2. If the  Key is pressed, the display returns to the main menu of utility function mode.
3	<pre>A.EC0 Safety Setup Alarm Clr Start :[DATA] Return:[SET]</pre>		Press the  Key to clear the Safety Module: Confirmation Alarm. “Processing” flashes on the menu display while the alarm is being cleared. When the alarm has been cleared, “DONE” flashes in the status display for approx. one second. Note: If an attempt to clear the alarm fails: “ERROR” flashes in the status display for approx. one second, and the display returns to the setup alarm clear execution screen. Try to perform the operation again.
4	<pre>A.EC0 -FUNCTION- Fn043 SOM PrmInit Fn044 SOM AlmClr Fn080 Pole Detect Fn200 TuneLvISet</pre>		Press the  Key to return to the main menu of utility function mode.

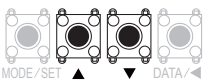
Note: If alarm A.EB0 (Safety Module: System Malfunction) occurs during operation, “NO-OP” is displayed in the status display and “SYSTEM ERROR” flashes on the screen. Press the  Key to display the main menu of utility function mode and make the settings again.

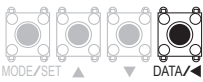
(2) Operating from the Panel Operator

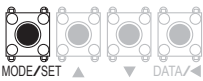
The procedure for operating from the panel operator is shown below.

Step	Display After Operation	Keys	Operation
1			Press the MODE/SET Key to select the utility function mode.
2			Press the UP or DOWN Key to display “Fn044.”
3			Press the DATA/SHIFT Key for at least one second to display the setup alarm clear execution screen. Note: If the cause of the Safety Module: Confirmation Alarm (A.EC0) is cleared: “No-oP” is displayed in the status display for approx. one second and the display return to the utility function selection screen.
4			Press the MODE/SET Key to execute the Safety Option Module Setup Alarm Clear. When the alarm has been cleared, “donE” flashes for approx. one second. Note: If an attempt to clear the alarm fails: “Error” flashes for approx. one second, and the display returns to step 3. Try to perform the operation again.
5			Press the DATA/SHIFT Key for at least one second to return to the utility function selection screen.

Note: If the following events occur while a parameter is being edited, the utility function is ended forcibly before the results are confirmed, and the status is displayed in the panel. If this occurs, execute the utility function again.

- If an alarm occurs while the utility function is being executed from the panel operator
- If a digital operator is connected to the SERVOPACK

8.7 Related Utility Functions

When using the Safety Module, the following information about the Safety Module is added to the utility functions used in the SERVOPACK. For details on these functions, refer to the manual of your SERVOPACK.

8.7.1 Software Version Display (Fn012)

This function is used to check the software version of the Safety Module.

8.7.2 Resetting Configuration Error in Option Modules (Fn014)

If the Safety Module being used is changed, or if an unsupported Safety Module is connected to the SERVOPACK, alarm A.E71 (Safety Option Module Detection Failure) occurs. This function is used to clear this alarm.

8.7.3 Display of SERVOPACK and Servomotor ID (Fn01E)

This function is used to check the ID information of the Safety Module.

Monitor Mode

This chapter describes the monitor mode that is used when a Safety Module is connected to the SERVOPACK.

9.1 Overview	9-2
9.1.1 List of Monitor Modes	9-2
9.1.2 Status Display	9-3
9.2 Monitoring from the Panel Operator and Digital Operator	9-5
9.2.1 Safety Module I/O Signal Monitor (Un016)	9-5
9.2.2 Safety Module Safety Function Status (Un017)	9-5
9.2.3 Safety Module System Status (Un018)	9-6
9.2.4 Time until Arrival at Safety Speed (Un019 and Un01A)	9-7
9.2.5 Active Mode Reference Speed (Un01B)	9-8
9.2.6 Safety Module Motor Speed (Un01C)	9-8
9.2.7 Safety Module Motor Position (Un01D)	9-8
9.2.8 Safety Module Monitoring Speed (Un01E, Un01F)	9-8
9.3 Monitoring Over the Network	9-9
9.3.1 SERVOPACK for Use with MECHATROLINK-II Communications Reference	9-9
9.3.2 SERVOPACK for Use with MECHATROLINK-III Communications Reference	9-10
9.3.3 SERVOPACK for Use with MECHATROLINK-4 Communications Reference	9-12
9.3.4 SERVOPACK for Use with Command Option Module	9-13

9.1 Overview

The Monitor Mode is used to display the operating status of the SERVOPACK or Safety Module. When a Safety Module is connected to the SERVOPACK, the items related to the Safety Module are added to the monitor mode displays of the SERVOPACK.

9.1.1 List of Monitor Modes

The monitor modes related to the Safety Module are shown below. For details on monitor mode, refer to the manual for your SERVOPACK.

Parameter No.	Display Contents	Reference
Un016 *	Safety Module I/O Signal Monitor	9.2.1
Un017 *	Safety Module Safety Function Status	9.2.2
Un018 *	Safety Module System Status	9.2.3
Un019 *	Time A until Arrival at Safety Speed	9.2.4
Un01A *	Time B until Arrival at Safety Speed	9.2.4
Un01B	Active Mode Reference Speed	9.2.5
Un01C	Safety Module Motor Speed	9.2.6
Un01D	Safety Module Motor Position	9.2.7
Un01E	Safety Module Monitoring Speed A	9.2.8
Un01F	Safety Module Monitoring Speed B	9.2.8

- * When the following alarms are occurred, these parameters are not displayed on the digital operator and the panel.
- Alarm A.C90 (Encoder Communications Error)
 - Alarm A.C91 (Encoder Communications Position Data Error)
 - Alarm A.C92 (Encoder Communications Timer Error)

9.1.2 Status Display

The operating status of the safety functions can be checked from the digital operator, or panel operator displays.

A safety function has the following operating states:

- Deceleration monitoring
- Safe state
- Safe (HWBB) state

(1) Displaying the Status on the Digital Operator

When a digital operator is connected, the SERVOPACK status is displayed at the top left of the display screen.

For details on the basic operation and display of the digital operator, *Σ-V Series User's Manual Operation of Digital Operator* (No.: SIEP S800000 55) or the *Σ-7 Series Digital Operator Operating Manual* (No.: SIEP S80001 33).

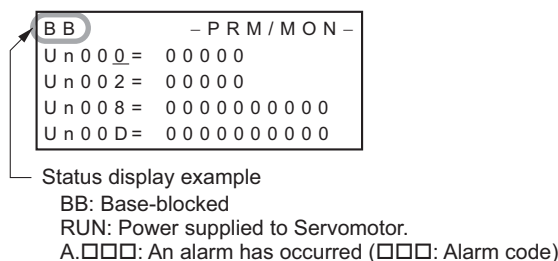

■ Deceleration monitoring

During deceleration monitoring, the current status and “SF-ON,” which indicates that deceleration monitoring is in progress, are displayed alternately in the status display.

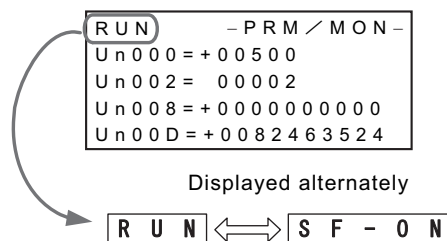

■ Safe State

During the safe state, the current status and “SAFE,” which indicates the safe state when the HWBB function is not operating, are displayed alternately in the status display.

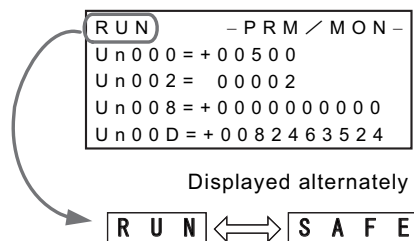

■ Safe (HWBB) State

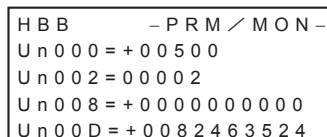

During the safe (HWBB) state, “HBB” is displayed in the status display.



(2) Displaying the Status on the Panel



■ Deceleration Monitoring

During deceleration monitoring, the panel display is as shown below.

SERVOPACK	Display
Analog voltage and pulse train reference model	Flashing 
<ul style="list-style-type: none"> • M-II communications reference model • M-III communications reference model • M-4 communications reference model • Command option attachable type 	Flashing 

■ Safe State

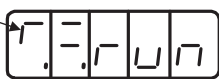
During the safe state (when the HWBB function is not operating), the panel display is as shown below:

SERVOPACK	Display
Analog voltage and pulse train reference model	Lit 
<ul style="list-style-type: none"> • M-II communications reference model • M-III communications reference model • M-4 communications reference model • Command option attachable type 	Lit 

■ Safe (HWBB) State

During the safe (HWBB) state, the panel display is shown below.

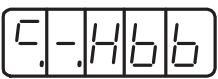
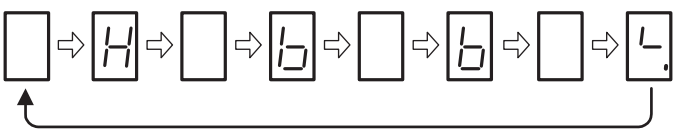
SERVOPACK	Display
Analog voltage and pulse train reference model	
<ul style="list-style-type: none"> • M-II communications reference model • M-III communications reference model • M-4 communications reference model • Command option attachable type 	

9.2 Monitoring from the Panel Operator and Digital Operator

This section describes the contents displayed when information related to the safety functions is checked on the panel operator and digital operator.

For details on how to perform operations with the panel operator and Digital Operator, refer to the following manuals:

- Panel Operator: Σ -V Series/Large-Capacity Σ -V Series User's Manual Design and Maintenance or Σ -7 Series Σ -7S SERVOPACK Product Manual
- Digital Operator: Σ -V Series User's Manual Operation of Digital Operator or Σ -7 Series Digital Operator Operating Manual

9.2.1 Safety Module I/O Signal Monitor (Un016)

Parameter No.	Name	Unit	Display Attribute
Un016	Safety Module I/O Signal Monitor	–	Bit
Bit	Name	Value	Description
0	Safety Request Input Signal A1	0	The Safety Request Input Signal A1 turns OFF.
		1	The Safety Request Input Signal A1 turns ON.
1	Safety Request Input Signal A2	0	The Safety Request Input Signal A2 turns OFF.
		1	The Safety Request Input Signal A2 turns ON.
2	Safety Request Input Signal B1	0	The Safety Request Input Signal B1 turns OFF.
		1	The Safety Request Input Signal B1 turns ON.
3	Safety Request Input Signal B2	0	The Safety Request Input Signal B2 turns OFF.
		1	The Safety Request Input Signal B2 turns ON.
4	External Device Monitor Output Signal A	0	The External Device Monitor Output Signal A turns OFF.
		1	The External Device Monitor Output Signal A turns ON.
5	External Device Monitor Output Signal B	0	The External Device Monitor Output Signal B turns OFF.
		1	The External Device Monitor Output Signal B turns ON.
6-7	Reserved	–	–

9.2.2 Safety Module Safety Function Status (Un017)

The operation of the Safety Module safety functions is classified into three states: Monitoring, Safe, and HWBB.

Parameter No.	Name	Unit	Display Attribute
Un017	Safety Module Safety Function Status	–	Bit
Bit	Name	Value	Description
0	Safety Function A – Monitoring	0	–
		1	Deceleration monitoring is in progress.
1	Safety Function A – Safe	0	–
		1	Safe state
2	Safety Function A – HWBB	0	–
		1	HWBB function is operating.
3	Reserved	–	–
4	Safety Function B – Monitoring	0	–
		1	Deceleration monitoring is in progress.
5	Safety Function B – Safe	0	–
		1	Safe state

(cont'd)

Parameter No.	Name	Unit	Display Attribute
6	Safety Function B – HWBB	0	–
		1	HWBB function is operating.
7	Reserved	–	–

The operating status of one safety function is affected by the operating status of the other safety function.

The relationship between the operating status of the safety functions and the monitor display is described below.

Operating State of the Other Safety Function	Operating State of the Safety Function			
	Standby	Monitoring	Safe State	HWBB
Standby	Monitoring = 0	Monitoring = 1	Monitoring = 1	Monitoring = 0
	Safe = 0	Safe = 0	Safe = 1	Safe = 1
	HWBB = 0	HWBB = 0	HWBB = 0	HWBB = 1
Deceleration monitoring	Monitoring = 0	Monitoring = 1	Monitoring = 1	Monitoring = 0
	Safe = 0	Safe = 0	Safe = 1	Safe = 1
	HWBB = 0	HWBB = 0	HWBB = 0	HWBB = 1
Safe state	Monitoring = 0	Monitoring = 1	Monitoring = 1	Monitoring = 0
	Safe = 0	Safe = 0	Safe = 1	Safe = 1
	HWBB = 0	HWBB = 0	HWBB = 0	HWBB = 1
HWBB	Monitoring = 0	Monitoring = 0	Monitoring = 0	Monitoring = 0
	Safe = 0	Safe = 1	Safe = 1	Safe = 1
	HWBB = 0	HWBB = 1	HWBB = 1	HWBB = 1

9.2.3 Safety Module System Status (Un018)

This monitor mode displays the operation of the Safety Module according to the state of Safety Function A and Safety Function B.

Parameter No.	Name	Unit	Display Attribute	
Un018	Safety Module System Status	–	Bit	
Bit	Name	Value	Description	Remarks
0	Safety Function – Monitoring	0	–	Monitoring is in progress for either Safety Function A or Safety Function B, or for both.
		1	Monitoring is in progress.	
1	Safety Function – Safe	0	–	Both Safety Function A and Safety Function B are in the safe state.
		1	Safe state	
2	Safety Function – HWBB	0	–	The HWBB function is operating for either Safety Function A, Safety Function B, or both.
		1	HWBB function is operating.	
3	Reserved	–	–	–
4	Active Mode State	0	Standby or not selected	–
		1	Operating	
5-7	Reserved	–	–	–

9.2.4 Time until Arrival at Safety Speed (Un019 and Un01A)

This monitor mode displays the time period until the motor reaches a safe speed after the safety request signal is input.

Parameter No.	Name	Unit	Remarks
Un019	Time A until Arrival at Safety Speed	ms	Initial display after system reset: 0
Un01A	Time B until Arrival at Safety Speed	ms	

The measurement of the time period until the motor reaches a safe speed depends on the selected safety function as shown below:

Safety Function	Measurement of Safe Speed
SBB	The time period until the motor reaches a safe speed is not measured. The value is always "0."
SBB-D	The time period is measured by assuming that a speed value within the speed detection error is the safe speed.
SPM-D	The time period is measured by assuming that a speed value within the speed detection error is the safe speed.
SLS-D	The time period is measured by assuming that the constant monitoring speed is the safe speed.

The characteristics of measuring the time period until the motor reaches a safe speed are as follows:

- The time period is measured from the time the safety request input state turns ON until the motor speed reaches the safe speed.
- The measured time is updated whenever the motor speed reaches the safe speed.
- Monitoring is performed until the safety request input state turns OFF.

The specifications of measuring the time period until the motor reaches a safe speed are shown below.

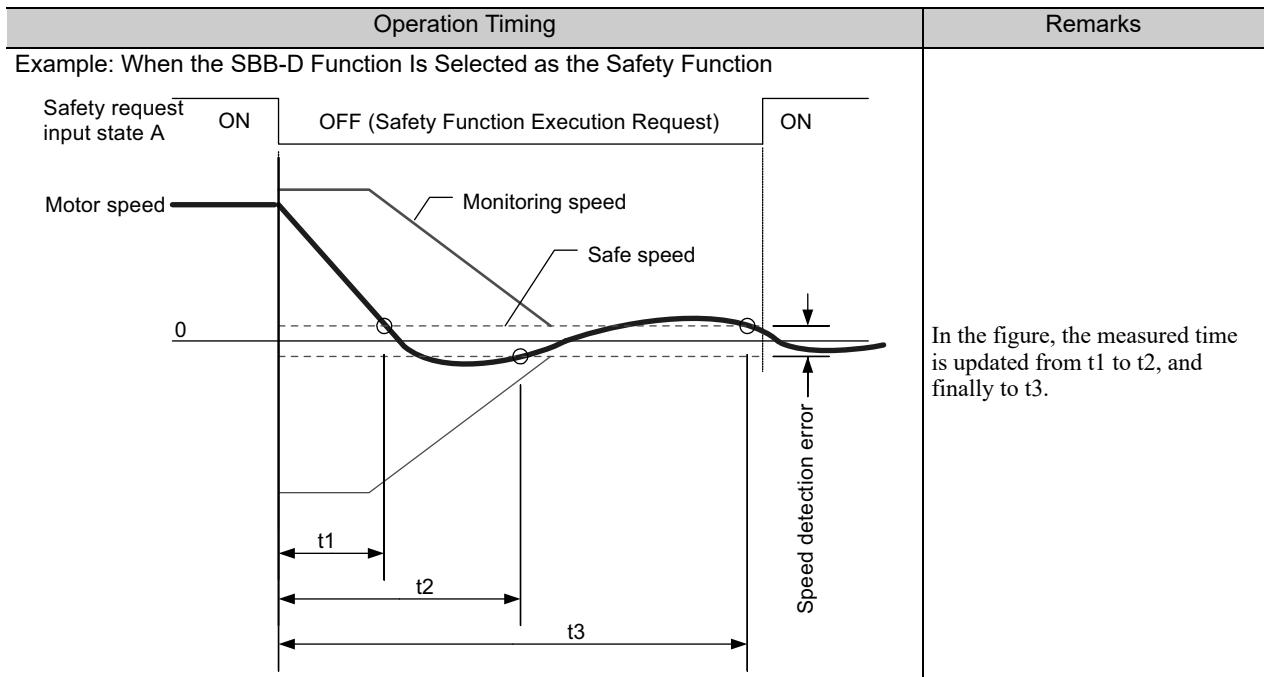

9.2.5 Active Mode Reference Speed (Un01B)

This monitor mode displays the internal speed reference of the SERVOPACK that uses the Active Mode Function.

Parameter No.	Name	Unit	Remarks
Un01B	Active Mode Reference Speed	Rotational motor: min^{-1}	Initial display after system reset: 0
		Linear motor: mm/s	

9.2.6 Safety Module Motor Speed (Un01C)

This monitor mode displays the motor speed that is detected by the Safety Module. The speed is shown as an absolute value regardless of the rotation (travel) direction.

Parameter No.	Name	Unit	Remarks
Un01C	Safety Module Motor Speed	Rotational motor: min^{-1}	-
		Linear motor: mm/s	

9.2.7 Safety Module Motor Position (Un01D)

In this monitor mode, the distance that the Safety Module detected the motor to have moved is displayed when the SPM-D function is used.

Parameter No.	Name	Unit	Remarks
Un01D	Safety Module Motor Position	edge	Pulses multiplied by 4

9.2.8 Safety Module Monitoring Speed (Un01E, Un01F)

This monitor mode displays the monitoring speed when a safety function is in operation (Safety Function A or Safety Function B). The speed is shown as an absolute value regardless of the rotation (travel) direction.

Parameter No.	Name	Unit	Remarks
Un01E	Safety Module Monitoring Speed A	Rotational motor: min^{-1}	-
		Linear motor: mm/s	
Un01F	Safety Module Monitoring Speed B	Rotational motor: min^{-1}	-
		Linear motor: mm/s	

9.3 Monitoring Over the Network

In a SERVOPACK for use with MECHATROLINK-II/-III/-4 communications reference, monitoring can be performed via MECHATROLINK-II/-III/-4 communications. In a SERVOPACK for use with the Command Option Module, monitoring can be performed over the field network of the Command Option Module. However, a function for acquiring the monitor information of the Safety Module must be installed in the Command Option Module. These monitoring functions are described below.

9.3.1 SERVOPACK for Use with MECHATROLINK-II Communications Reference

When Option Monitor 1 or 2 is allocated to MONITOR 1, 2, 3, or 4 in the Monitor Selection (SEL_MON1/2/3/4) Field, the I/O signals of the Safety Module and the operating state of the safety functions can be monitored via MECHATROLINK-II communications when a specified value is set in the following parameters.

(1) Allocating Monitor Information

Parameter No.	Name	Set Value	Contents
Pn824	Option Monitor 1	003Ch	The monitor information of the Safety Option Module is allocated to Option 1.
Pn825	Option Monitor 2	003Ch	The monitor information of the Safety Option Module is allocated to Option 2.

Note: For details on the MECHATROLINK-II communications commands, refer to the *Σ-V Series/DC Power Input Σ-V Series/Σ-V Series for Large-Capacity Models User's Manual MECHATROLINK-II Command* or the *Σ-7 Series MECHATROLINK-II Communications Command Manual*.

(2) Monitor Information

The monitor information of the Safety Module is described below.

Bit	Name	Display Contents
d0	Safety Request Input Signal A1	0 = OFF, 1 = ON
d1	Safety Request Input Signal A2	0 = OFF, 1 = ON
d2	Safety Request Input Signal B1	0 = OFF, 1 = ON
d3	Safety Request Input Signal B2	0 = OFF, 1 = ON
d4	External Device Monitor Signal A	0 = OFF, 1 = ON
d5	External Device Monitor Signal B	0 = OFF, 1 = ON
d6-7	Reserved	–
d8	Safety Function	Monitoring 0 = –, 1 = Deceleration monitoring is in progress.
d9		Safe 0 = –, 1 = Safe state
d10		HWBB 0 = –, 1 = HWBB function is operating.
d11		Reserved –
d12-15	Reserved	–
d16	Active Mode State	0 = Standby or not selected, 1 = Operating
d17-31	Reserved	–

9.3.2 SERVOPACK for Use with MECHATROLINK-III Communications Reference

MECHATROLINK-III Communications Reference SERVOPACKs has multiple fields that can monitor the I/O signals of the Safety Module and operating status of the safety functions via MECHATROLINK-III communications. Refer to the following information for details.

(1) When connected to the MP-series controller

When Option Monitor 1 or 2 is allocated to MONITOR 1, 2, 3, or 4 in the Monitor Selection (SEL_MON1/2/3/4) Field, the I/O signals of the Safety Module and the operating state of the safety functions can be monitored via MECHATROLINK-III communications when a specified value is set in the following parameters.

■ Allocating Monitor Information

Parameter No.	Name	Set Value	Contents
Pn824	Option Monitor 1	003Ch	The monitor information of the Safety Option Module is allocated to Option 1.
Pn825	Option Monitor 2	003Ch	The monitor information of the Safety Option Module is allocated to Option 2.

Note: For details on the MECHATROLINK-III communications commands, refer to the *Σ-V Series/DC Power Input Σ-V Series/Σ-V Series for Large-Capacity Models User's Manual MECHATROLINK-III Standard Servo Profile Command Manual* or the *Σ-7 Series MECHATROLINK-III Communications Command Manual*.

(2) When connected to other controllers

■ Monitor fields and parameter settings

The monitor fields and parameter settings to specify monitor information are shown in the following table.

Monitor Field	Parameter Settings for Monitor Information
CPRM_SEL_MON1	One of the following values is set. <ul style="list-style-type: none"> Common parameters 87 PnB0E = 000Eh, and, Pn824 = 003Ch Common parameters 87 PnB0E = 000Fh, and, Pn825 = 003Ch
CPRM_SEL_MON2	One of the following values is set. <ul style="list-style-type: none"> Common parameters 88 PnB10 = 000Eh, and, Pn824 = 003Ch Common parameters 88 PnB10 = 000Fh, and, Pn825 = 003Ch
MONITOR1	One of the following values is set. <ul style="list-style-type: none"> SVCMD_CTRL. SEL_MON1 = 000Eh, and, Pn824 = 003Ch SVCMD_CTRL. SEL_MON1 = 000Fh, and, Pn825 = 003Ch
MONITOR2	One of the following values is set. <ul style="list-style-type: none"> SVCMD_CTRL. SEL_MON2 = 000Eh, and, Pn824 = 003Ch SVCMD_CTRL. SEL_MON2 = 000Fh, and, Pn825 = 003Ch
MONITOR3	One of the following values is set. <ul style="list-style-type: none"> SVCMD_CTRL. SEL_MON3 = 000Eh, and, Pn824 = 003Ch SVCMD_CTRL. SEL_MON3 = 000Fh, and, Pn825 = 003Ch
MONITOR4	One of the following values is set. <ul style="list-style-type: none"> SUB_CTRL. SEL_MON4 = 000Eh, and, Pn824 = 003Ch SUB_CTRL. SEL_MON4 = 000Fh, and, Pn825 = 003Ch
MONITOR5	One of the following values is set. <ul style="list-style-type: none"> SUB_CTRL. SEL_MON5 = 000Eh, and, Pn824 = 003Ch SUB_CTRL. SEL_MON5 = 000Fh, and, Pn825 = 003Ch
MONITOR6	One of the following values is set. <ul style="list-style-type: none"> SUB_CTRL. SEL_MON6 = 000Eh, and, Pn824 = 003Ch SUB_CTRL. SEL_MON6 = 000Fh, and, Pn825 = 003Ch

■ Monitor Information

The displayed contents of the monitor fields are shown in the following table.

Bit	Name	Display Contents
d0	Safety Request Input Signal A1	0 = OFF, 1 = ON
d1	Safety Request Input Signal A2	0 = OFF, 1 = ON
d2	Safety Request Input Signal B1	0 = OFF, 1 = ON
d3	Safety Request Input Signal B2	0 = OFF, 1 = ON
d4	External Device Monitor Signal A	0 = OFF, 1 = ON
d5	External Device Monitor Signal B	0 = OFF, 1 = ON
d6-7	Reserved	–
d8	Safety Function	Monitoring 0 = –, 1 = Deceleration monitoring is in progress.
d9		Safe 0 = –, 1 = Safe state
d10		HWBB 0 = –, 1 = HWBB function is operating.
d11		Reserved –
d12-15	Reserved	–
d16	Active Mode State	0 = Standby or not selected, 1 = Operating
d17-31	Reserved	–

■ Details on Parameter Settings for Monitor Information

Common parameter No.	Set value	Contents
87 PnB0E, 88 PnB10	000Eh	OMN1 (Optional monitor 1) (Select the monitor data specified by Pn824.)
	000Fh	OMN2 (Optional monitor 2) (Select the monitor data specified by Pn825.)

Parameter No.	Name	Set Value	Contents
Pn824	Option Monitor 1	003Ch	The monitor information of the Safety Option Module is allocated to Option 1.
Pn825	Option Monitor 2	003Ch	The monitor information of the Safety Option Module is allocated to Option 2.

Command field	Set value	Contents
SVCMD_CTRL	SEL_MON1 to 3	000Eh OMN1 (Option Monitor 1) (Select the monitor data specified by Pn824.)
		000Fh OMN2 (Option Monitor 2) (Select the monitor data specified by Pn825.)
SUB_CTRL	SEL_MON4 to 6	000Eh OMN1 (Option Monitor 1) (Select the monitor data specified by Pn824.)
		000Fh OMN2 (Option Monitor 2) (Select the monitor data specified by Pn825.)

Note: For details on the MECHATROLINK-III communications commands, refer to the Σ -V Series/DC Power Input Σ -V Series/ Σ -V Series for Large-Capacity Models User's Manual MECHATROLINK-III Commands or the Σ -7 Series MECHATROLINK-III Standard Servo Profile Command Manual.

9.3.3 SERVOPACK for Use with MECHATROLINK-4 Communications Reference

MECHATROLINK-4 Communications Reference SERVOPACKs has multiple fields that can monitor the I/O signals of the Safety Module and operating status of the safety functions via MECHATROLINK-4 communications. Refer to the following information for details.

(1) When connected to the MP-series controller

When Option Monitor 1 or 2 is allocated to MONITOR 1, 2, 3, or 4 in the Monitor Selection (SEL_MON1/2/3/4) Field, the I/O signals of the Safety Module and the operating state of the safety functions can be monitored via MECHATROLINK-4 communications when a specified value is set in the following parameters.

■ Allocating Monitor Information

Parameter No.	Name	Set Value	Contents
Pn824	Option Monitor 1	003Ch	The monitor information of the Safety Option Module is allocated to Option 1.
Pn825	Option Monitor 2	003Ch	The monitor information of the Safety Option Module is allocated to Option 2.

Note: For details on the MECHATROLINK-4 communications commands, refer to the *Σ-V Series/DC Power Input Σ-V Series/Σ-V Series for Large-Capacity Models User's Manual MECHATROLINK-4 Standard Servo Profile Command Manual* or the *Σ-7 Series MECHATROLINK-4 Communications Command Manual*.

(2) When connected to other controllers

■ Monitor fields and parameter settings

The monitor fields and parameter settings to specify monitor information are shown in the following table.

Monitor Field	Parameter Settings for Monitor Information
CPRM_SEL_MON1	Common parameters 87 PnB0E = 008Ch
CPRM_SEL_MON2	Common parameters 88 PnB10 = 008Ch
CPRM_SEL_MON3	Common parameters E0 PnBC0 = 008Ch
CPRM_SEL_MON4	Common parameters E1 PnBC2 = 008Ch
CPRM_SEL_MON5	Common parameters E2 PnBC4 = 008Ch
CPRM_SEL_MON6	Common parameters E3 PnBC6 = 008Ch
CPRM_SEL_MON7	Common parameters E4 PnBC8 = 008Ch
CPRM_SEL_MON8	Common parameters E5 PnBCA = 008Ch
CPRM_SEL_MON9	Common parameters E6 PnBCC = 008Ch
CPRM_SEL_MON10	Common parameters E7 PnBCE = 008Ch
MONITOR1	One of the following values is set. <ul style="list-style-type: none"> SVCMD_CTRL. SEL_MON1 = 000Eh, and, Pn824 = 003Ch SVCMD_CTRL. SEL_MON1 = 000Fh, and, Pn825 = 003Ch
MONITOR2	One of the following values is set. <ul style="list-style-type: none"> SVCMD_CTRL. SEL_MON2 = 000Eh, and, Pn824 = 003Ch SVCMD_CTRL. SEL_MON2 = 000Fh, and, Pn825 = 003Ch
MONITOR3	SVCMD_CTRL. SEL_MON3 = 008Ch
MONITOR4	One of the following values is set. <ul style="list-style-type: none"> SUB_CTRL. SEL_MON4 = 000Eh, and, Pn824 = 003Ch SUB_CTRL. SEL_MON4 = 000Fh, and, Pn825 = 003Ch
MONITOR5	One of the following values is set. <ul style="list-style-type: none"> SUB_CTRL. SEL_MON5 = 000Eh, and, Pn824 = 003Ch SUB_CTRL. SEL_MON5 = 000Fh, and, Pn825 = 003Ch
MONITOR6	One of the following values is set. <ul style="list-style-type: none"> SUB_CTRL. SEL_MON6 = 000Eh, and, Pn824 = 003Ch SUB_CTRL. SEL_MON6 = 000Fh, and, Pn825 = 003Ch

■ Monitor Information

The displayed contents of the monitor fields are shown in the following table.

Bit	Name	Display Contents
d0	Safety Request Input Signal A1	0 = OFF, 1 = ON
d1	Safety Request Input Signal A2	0 = OFF, 1 = ON
d2	Safety Request Input Signal B1	0 = OFF, 1 = ON
d3	Safety Request Input Signal B2	0 = OFF, 1 = ON
d4	External Device Monitor Signal A	0 = OFF, 1 = ON
d5	External Device Monitor Signal B	0 = OFF, 1 = ON
d6-7	Reserved	–
d8	Safety Function	Monitoring 0 = –, 1 = Deceleration monitoring is in progress.
d9		Safe 0 = –, 1 = Safe state
d10		HWBB 0 = –, 1 = HWBB function is operating.
d11		Reserved –
d12-15	Reserved	–
d16	Active Mode State	0 = Standby or not selected, 1 = Operating
d17-31	Reserved	–

■ Details on Parameter Settings for Monitor Information

Common Parameter No.	Set Value	Contents
87 PnB0E, 88 PnB10, E0 PnBC0 to E7 PnBCE	008Ch	Selects the monitor data of the Safety Option Module.

Parameter No.	Name	Set Value	Contents
Pn824	Option Monitor 1	003Ch	The monitor information of the Safety Option Module is allocated to Option 1.
Pn825	Option Monitor 2	003Ch	The monitor information of the Safety Option Module is allocated to Option 2.

Command Field	Set Value	Content
SVCMD_CTRL	SEL_MON1 to 2	000Eh OMN1 (Optional monitor 2) (Selects the monitor data specified at parameter Pn824.)
		000Fh OMN2 (Optional monitor 2) (Selects the monitor data specified at parameter Pn825.)
	SEL_MON3	008Ch Safety Option Module
SUB_CTRL	SEL_MON4 to 6	000Eh OMN1 (Optional monitor 1) (Selects the monitor data specified at parameter Pn824.)
		000Fh OMN2 (Optional monitor 2) (Selects the monitor data specified at parameter Pn825.)

Note: For details on the MECHATROLINK-4 communications commands, refer to the Σ -7 Series MECHATROLINK-4 Communications Standard Servo Profile Command Manual.

9.3.4 SERVOPACK for Use with Command Option Module

A SERVOPACK for use with Command Option Module has a function for providing the monitor information of the Safety Module to the Command Option Module that is connected. For details, refer to the manual of the Command Option Module that is connected to the Command Option Attachable-type SERVOPACK.

Active Mode Function

This chapter describes the Active Mode Function, which is an additional function of the SERVOPACK available when used with the Safety Module.

10.1 Overview	10-2
10.2 Basic Functions	10-2
10.2.1 Internal Deceleration References	10-3
10.2.2 Active Mode Hold Time	10-3
10.2.3 Position Error Level for Releasing Active Mode	10-4
10.2.4 Speed Reference Level for Releasing Active Mode	10-5
10.2.5 Monitoring Active Mode Function	10-6
10.3 Settings	10-12
10.4 Returning Method	10-13
10.4.1 Returning Conditions	10-13
10.4.2 SERVOPACK for Use with Analog Voltage and Pulse Train Reference	10-13
10.4.3 SERVOPACK for Use with MECHATROLINK-II Communications Reference	10-15
10.4.4 SERVOPACK for Use with MECHATROLINK-III Communications Reference	10-17
10.4.5 SERVOPACK for Use with MECHATROLINK-4 Communications Reference	10-19
10.4.6 SERVOPACK for Use with Command Option Module	10-20
10.5 Exceptional Operation	10-21
10.6 Related SERVOPACK Functions	10-22
10.6.1 Utility Functions	10-22
10.6.2 Overtravel	10-23
10.6.3 Servo ON Command	10-23
10.6.4 Zero-clamp Function	10-23
10.6.5 Speed Feedforward Function	10-23
10.6.6 Torque Feedforward Function	10-23

10.1 Overview

Active Mode Function is used to stop the motor according to the internal deceleration reference of the SERVOPACK that is set in the parameters, when the Safety Request Input Signal turns OFF. Independent deceleration references can be set for Safety Function A and Safety Function B.

Note: Active Mode Function is not a safety function of the harmonized standards. Consider this when designing the system.

10.2 Basic Functions

The basic functions in Active Mode Function are as follows:

- Internal Deceleration References (Pn622, Pn623, and Pn624)
- Active Mode Hold Time (Pn625)
- Position Error Level for Releasing Active Mode (Pn626)
- Speed Reference Level for Releasing Active Mode (Pn628)

Active Mode Function can be used when the control mode is set to position control or speed control.

Note: Do not use Active Mode Function when the control mode is set to torque control. If used, the internal elements may deteriorate leading to malfunctioning.

If the motor stops due to the operation of Active Mode Function, Active Mode Function can be canceled to return to the normal operation when all of the following conditions are met.

- The servo ON command must be OFF.
- The corresponding Safety Request Input Signal must be ON.

Restart the normal operation after Active Mode Function has been canceled.

The Active Mode Function of the Safety Module has the following basic features.

- Can be selected by parameter setting.
- “ACT” is shown on the status display while in Active Mode Function.
- The internal deceleration reference of the SERVOPACK can be set by the parameter.
- The deceleration reference can be separately set for Safety Functions A and B, and the Active Mode Function operates for each safety function separately.
- When Safety Functions A and B operate in Active Mode Function concurrently, the motor will be controlled at the lower of two speeds set as the deceleration reference.

If either of the following occurs while in Active Mode Function, the Active Mode Function will be canceled.

- The servo ready signal is OFF.
- An alarm occurs.

10.2.1 Internal Deceleration References

The parameters for the internal deceleration references in Active Mode Function are as follows:

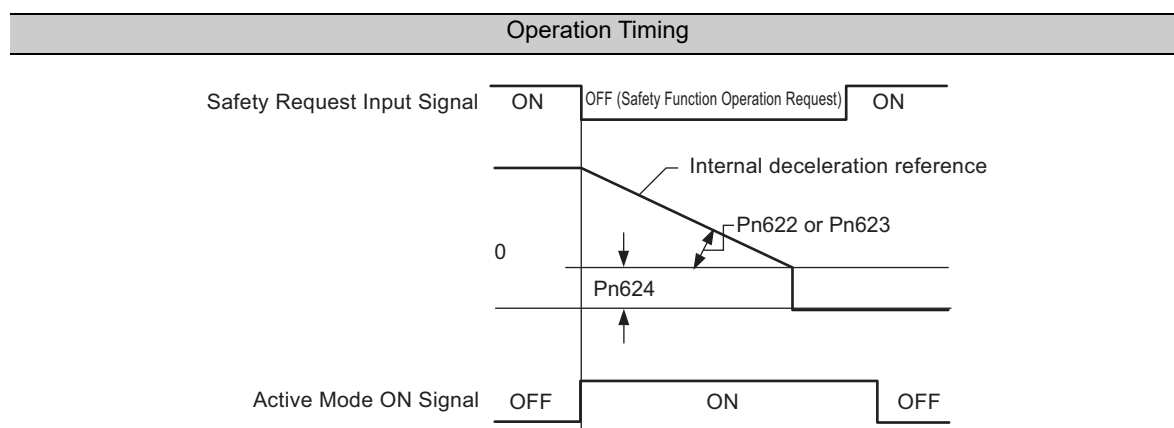

Parameter No.	Name	Setting Range	Units	Factory Setting	When Enabled
Pn622	Constant of Deceleration for Safety Function A	1 to 30000	Rotational motor: min^{-1}/s Linear motor: mm/s^2	10000	Immediately
Pn623	Constant of Deceleration for Safety Function B	1 to 30000	Rotational motor: min^{-1}/s Linear motor: mm/s^2	10000	Immediately
Pn624	Motor Stop Detection Level for Active Mode	0 to 10000	Rotational motor: min^{-1} Linear motor: mm/s	10	Immediately

Note: If Active Mode is used when the control mode is set to torque control, the servo turns OFF. Stopping is performed according to the setting of Pn.001.0. For details, refer to the manual for your SERVOPACK.

10.2.2 Active Mode Hold Time

After the motor stops, the motor is placed in a servolock state in Active Mode Function for a specified time in accordance with the parameter setting. Using this function, the hold time can be set for the host controller to detect if the motor has stopped.

The Active Mode Hold Time is set in Pn625. This parameter applies to both Safety Function A and Safety Function B. Individual settings are not provided.

Parameter No.	Name	Setting Range	Units	Factory Setting	When Enabled
Pn625	Active Mode Hold Time	0 to 10000	10 ms	100	Immediately

After the motor stops, Active Mode Function continues for the Active Mode Hold Time (Pn625) regardless of the state of the Safety Request Input Signal.

If the Safety Request Input Signal turns ON after the Active Mode Hold Time (Pn625) elapses, Active Mode Function is canceled.

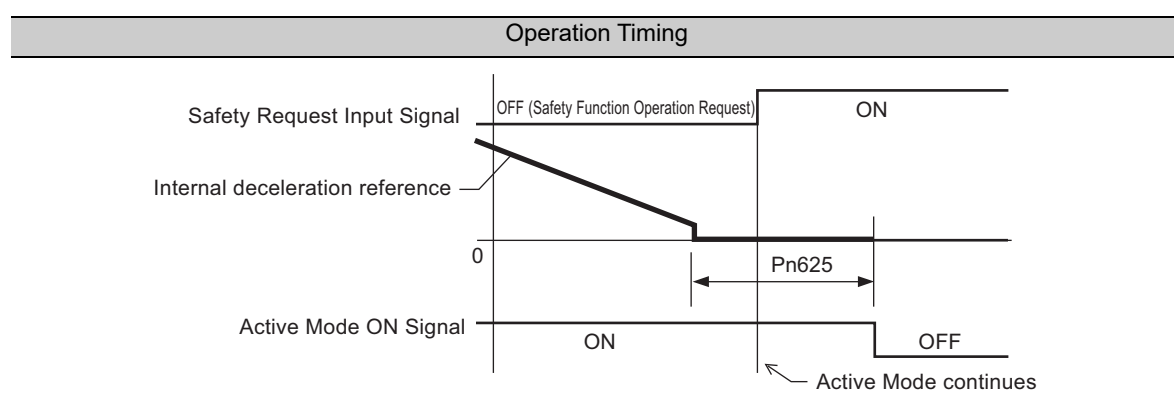

10.2.3 Position Error Level for Releasing Active Mode

The Position Error Level for Releasing Active Mode prevents the motor from moving unexpectedly when position control is used as the control method and Active Mode Function is canceled.

Besides the position reference from the host controller, Active Mode Function controls the motor based on the deceleration reference from the SERVOPACK. At this point, the difference between the position reference from the host controller and the actual motor position is maintained in the SERVOPACK as the position error. While a position error remains, do not cancel Active Mode Function. This would be dangerous because the motor might move unexpectedly to clear the position error and reset the position error to zero. To avoid this, an error level can be set to cancel the Active Mode Function.

The Position Error Level for Releasing Active Mode is set in Pn626. This parameter applies to both Safety Function A and Safety Function B. Individual settings are not provided.

Parameter No.	Name	Setting Range	Units	Factory Setting	When Enabled
Pn626	Position Error Level for Releasing Active Mode	1 to 1073741823	1 reference unit	100	Immediately

If the position error exceeds the value set in Pn626, Active Mode Function continues to operate regardless of the state of the Safety Request Input Signals.

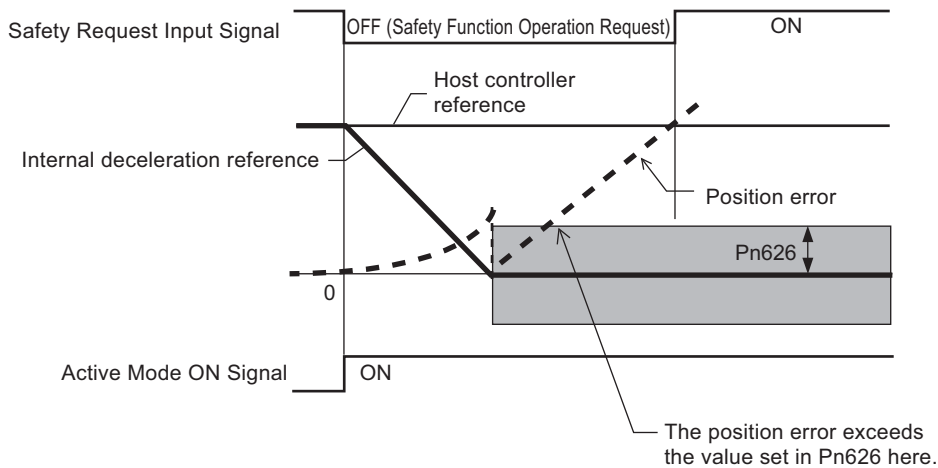

10.2.4 Speed Reference Level for Releasing Active Mode

The Speed Reference Level for Releasing Active Mode is used to prevent the sudden operation of the motor when Active Mode Function is canceled in speed control mode. Besides the speed reference from the host controller, Active Mode Function controls the motor based on the deceleration reference from the SERVO-PACK. Do not cancel Active Mode Function while the motor is stopping in Active Mode Function after the speed reference from the host controller has been input. This would be dangerous because the motor might move unexpectedly. To avoid this, a speed reference level can be set to cancel the Active Mode Function.

The Speed Reference Level for Releasing Active Mode is set in Pn628. This parameter applies to both Safety Function A and Safety Function B. Individual settings are not provided.

Parameter No.	Name	Setting Range	Units	Factory Setting	When Enabled
Pn628	Speed Reference Level for Releasing Active Mode	0 to 10000	Rotational motor: min^{-1} Linear motor: mm/s	10	Immediately

If the speed reference exceeds the value set in Pn628, Active Mode Function continues to operate regardless of the state of the Safety Request Input Signals.

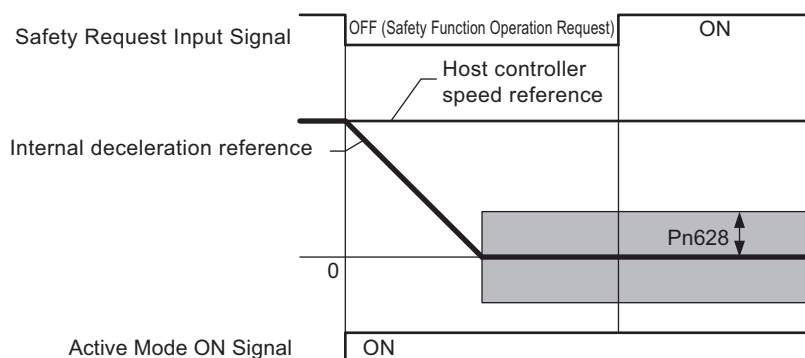

10.2.5 Monitoring Active Mode Function

Whether Active Mode Function is operating can be monitored by the following methods:

- All SERVOPACKs: Allocating the Active Mode output signal (/ACT_MOD) to CN1.
- M-II communications reference model: Using the I/O monitor (IO_MON) field.
- M-III communications reference model: Using the I/O signal monitor (SVCMD_IO) field.
- M-4 communications reference model: Using the input signal monitor (SVCMD_IN) field.
- Command option attachable type: Depends on the Command Option Module.

For details, refer to the user's manual of the Command Option Module connected to the SERVOPACK being used.

(1) Active Mode ON Signal

The operation of Active Mode Function can be monitored by allocating the Active Mode ON Signal to an output signal on CN1 of the SERVOPACK.

■ Active Mode ON Signal Allocations

Output Signal Names and Parameters	Output Signal	Cn1 Pin No.			Invalid (Not Used)
		25/(26) ^{*1}	27/(28) ^{*1}	29/(30) ^{*1}	
		1/(2) ^{*2}	23/(24) ^{*2}	25/(26) ^{*2}	
Active Mode ON Signal Pn518.0	/ACT_MOD	1	2	3	0 (Factory setting)
Pn512.0 = 1	Polarity inversion			0 (Factory setting: Polarity not inverted)	
Pn512.1 = 1	Polarity inversion				
Pn512.2 = 1	Polarity inversion				

*1. Pin numbers when using the following SERVOPACKs

Series	Communications reference model
Σ-V Series	Analog voltage and pulse train reference model
Large-Capacity Σ-V Series	Analog voltage and pulse train reference model
	M-II communications reference model
	M-III communications reference model
	Command option attachable type
Σ-7 Series Σ-7S	Analog voltage and pulse train reference model

*2. Pin numbers when using the following SERVOPACKs

Series	Communications reference model
Σ-V Series	M-II communications reference model
	M-III communications reference model
	Command option attachable type
Σ-7 Series Σ-7S	M-II communications reference model
	M-III communications reference model
	M-4 communications reference model

(2) MECHATROLINK-II I/O Monitor (IO_MON) Field

If the Active Mode ON Signal is allocated to CN1 in a SERVOPACK with MECHATROLINK-II Communications Reference, the operating state of Active Mode Function can be monitored in the I/O monitor field. The allocation of monitor information and information on the I/O monitor (IO_MON) field are given below. For details on allocation of the Active Mode ON Signal, refer to (1) *Active Mode ON Signal*.

■ Monitor Information Allocations

Parameter No.	Name	Setting Range	Units	Factory Setting	When Enabled
Pn81E	Input Signal Monitor Selection	–	–	0000	Immediately
Details	I/O Signal Monitor				
Pn81E.0	IO12 Signal Mapping				
	0 to 7	Same as the parameters of M-II communications reference model.			
	8	Σ-V Series/Σ-7 Series Σ-7S: Monitors the CN1-1 (2) output terminal. Large-Capacity Σ-V Series: Monitors the CN1-25 (26) output terminal.			
	9	Σ-V Series/Σ-7 Series Σ-7S: Monitors the CN1-23 (24) output terminal. Large-Capacity Σ-V Series: Monitors the CN1-27 (28) output terminal.			
Pn81E.1	IO13 Signal Mapping				
	0 to A	Same as the IO12 signal mapping			
Pn81E.2	IO14 Signal Mapping				
	0 to A	Same as the IO12 signal mapping			
Pn81E.3	IO15 Signal Mapping				
	0 to A	Same as the IO12 signal mapping			

■ Monitor Information

Bit	Name	Description	Display
d12	IO12	I/O signal of CN1 that is set in Pn81E.0	0 = OFF, 1 = ON
d13	IO13	I/O signal of CN1 that is set in Pn81E.1	0 = OFF, 1 = ON
d14	IO14	I/O signal of CN1 that is set in Pn81E.2	0 = OFF, 1 = ON
d15	IO15	I/O signal of CN1 that is set in Pn81E.3	0 = OFF, 1 = ON

Note: For details on the MECHATROLINK-II communications, refer to the *Σ-V Series/DC Power Input Σ-V Series/Σ-V Series for Large-Capacity Models User's Manual MECHATROLINK-II Command* or the *Σ-7 Series MECHATROLINK-II Communications Command Manual*.

(3) MECHATROLINK-III I/O Signal Monitor (SVCMD_IO) Field

If the Active Mode ON Signal is allocated to CN1 in a SERVOPACK with MECHATROLINK-III communications, the operating state of the Active Mode Function can be monitored in IO1 to IO8 in the I/O signal monitor (SVCMD_IO) field. The following tables provide information on the allocation of the output signal monitor and the I/O signal monitor (SVCMD_IO) field. For details on allocation of the Active Mode ON Signal, refer to (1) *Active Mode ON Signal*.

■ Monitor Information Allocation

Parameter No.	Name	Setting Range	Units	Factory Setting	When Enabled
Pn868	SVCMD_IO (output signal monitor) Allocation 1	0000 to 1717	–	n.0000	Immediately
Pn869	SVCMD_IO (output signal monitor) Allocation 2	0000 to 1717	–	n.0000	Immediately
Details	SVCMD_IO (I/O signal monitor) Bit Position Allocation			Remarks	
Pn868.0	Σ-V Series and Σ-7 Series Σ-7S: Allocation of bit position for monitoring the CN1-1 (2) output signal. Large-Capacity Σ-V Series: Allocation of bit position for monitoring the CN1-25 (26) output signal.				–
	0	D24 (IO1_STS1)			–
	1	D25 (IO2_STS1)			–
	2	D26 (IO3_STS1)			–
	3	D27 (IO4_STS1)			–
	4	D28 (IO5_STS1)			–
	5	D29 (IO6_STS1)			–
	6	D30 (IO7_STS1)			–
Pn868.1	Σ-V Series and Σ-7 Series Σ-7S: Enables or disables the allocated bit position for monitoring the CN1-1 (2) output signal. Large-Capacity Σ-V Series: Enables or disables the allocated bit position for monitoring the CN1-25 (26) output signal.				–
	0	Disabled			–
	1	Enabled			–
Pn868.2	Σ-V Series and Σ-7 Series Σ-7S: Allocation of bit position for monitoring the CN1-23 (24) output signal. Large-Capacity Σ-V Series: Allocation of bit position for monitoring the CN1-27 (28) output signal.				–
	0-7	Σ-V Series and Σ-7 Series Σ-7S: Same settings for the CN1-1 (2) output signal Large-Capacity Σ-V Series: Same settings for the CN1-25 (26) output signal			–
Pn868.3	Σ-V Series and Σ-7 Series Σ-7S: Enables or disables the allocated bit position for monitoring the CN1-23 (24) output signal. Large-Capacity Σ-V Series: Enables or disables the allocated bit position for monitoring the CN1-27 (28) output signal.				–
	0	Disabled			–
	1	Enabled			–

(cont'd)

Details	SVCMD_IO (I/O signal monitor) Bit Position Allocation		Remarks
Pn869.0	Σ -V Series and Σ -7 Series Σ -7S: Allocation of bit position for monitoring the CN1-25 (26) output signal. Large-Capacity Σ -V Series: Allocation of bit position for monitoring the CN1-29 (30) output signal.		–
	0-7	Σ -V Series: Same settings for the CN1-1 (2) output signal Large-Capacity Σ -V Series: Same settings for the CN1-25 (26) output signal	–
Pn869.1	Σ -V Series and Σ -7 Series Σ -7S: Enables or disables the allocated bit position for monitoring the CN1-25 (26) output signal. Large-Capacity Σ -V Series: Enables or disables the allocated bit position for monitoring the CN1-29 (30) output signal.		–
	0	Disabled	–
	1	Enabled	–
Pn869.2	–	Reserved (Do not change)	–
Pn869.3	–	Reserved (Do not change)	–

■ Monitor Information

Bit	Name	Description	Value	I/O Status
D24 to D31	IO1_STS1 to IO8_STS1	Monitors the CN1 output signal	0	OFF (Output transistor is open.)
			1	ON (Output transistor is closed.)
		Indicates the status of the CN1 output signal. Use any of the Pn868 and Pn869 to allocate bit positions for monitoring the CN1 output signal. When using these parameters, if the same bit position is allocated to more than two signals, the logical OR operator is used to send a signal.		

Note: For details, refer to the Σ -V Series/DC Power Input Σ -V Series/ Σ -V Series for Large-Capacity Models User's Manual MECHATROLINK-III Command or the Σ -7 Series MECHATROLINK-III Standard Profile Command Manual.

(4) MECHATROLINK-4 I/O Signal Monitor (SVCMD_IN) Field

If the Active Mode ON Signal is allocated to CN1 in a SERVOPACK with MECHATROLINK-4 communications, the operating state of the Active Mode Function can be monitored in IO_STS1 to IO_STS8 in the I/O signal monitor (SVCMD_IN) field. The following tables provide information on the allocation of the output signal monitor and the I/O signal monitor (SVCMD_IN) field. For details on allocation of the Active Mode ON Signal, refer to (1) *Active Mode ON Signal*.

■ Monitor Information Allocation

Parameter No.	Name	Setting Range	Units	Factory Setting	When Enabled
Pn868	SVCMD_IN (output signal monitor) Allocation 1	0000 to 1717	–	n.0000	Immediately
Pn869	SVCMD_IN (output signal monitor) Allocation 2	0000 to 1717	–	n.0000	Immediately
Details	SVCMD_IN (I/O signal monitor) Bit Position Allocation			Remarks	
Pn868.0	Allocation of bit position for monitoring the CN1-1 (2) output signal.			–	
	0	D24 (IO_STS1)	–		
	1	D25 (IO_STS2)	–		
	2	D26 (IO_STS3)	–		
	3	D27 (IO_STS4)	–		
	4	D28 (IO_STS5)	–		
	5	D29 (IO_STS6)	–		
	6	D30 (IO_STS7)	–		
Pn868.1	Enables or disables the allocated bit position for monitoring the CN1-1 (2) output signal.			–	
	0	Disabled	–		
	1	Enabled	–		
Pn868.2	Allocation of bit position for monitoring the CN1-23 (24) output signal.			–	
	0-7	Same settings for the CN1-1 (2) output signal		–	
Pn868.3	Enables or disables the allocated bit position for monitoring the CN1-23 (24) output signal.			–	
	0	Disabled	–		
	1	Enabled	–		
Pn869.0	Allocation of bit position for monitoring the CN1-25 (26) output signal.			–	
	0-7	Same settings for the CN1-1 (2) output signal		–	
Pn869.1	Enables or disables the allocated bit position for monitoring the CN1-25 (26) output signal.			–	
	0	Disabled	–		
	1	Enabled	–		
Pn869.2	–	Reserved (Do not change)		–	
Pn869.3	–	Reserved (Do not change)		–	

■ Monitor Information

Bit	Name	Description	Value	I/O Status
D24 to D31	IO_STS1 to IO_STS8	Monitors the CN1 output signal	0	OFF (Output transistor is open.)
			1	ON (Output transistor is closed.)
		Indicates the status of the CN1 output signal. Use any of the Pn868 and Pn869 to allocate bit positions for monitoring the CN1 output signal. When using these parameters, if the same bit position is allocated to more than two signals, the logical OR operator is used to send a signal.		

Note: For details, refer to the *Σ-7 Series MECHATROLINK-4 Standard Servo Profile Command Manual*.

10.3 Settings

This section describes the setup parameters of Active Mode Function.

Parameter No.	Name	Setting Range	Units	Factory Setting	When Enabled	
Pn621	Application Switch for Safety Function	–	–	0000	After resetting the system or are recalculating parameters	
	0	Selection of Active Mode for Safety Function A				
		0	Disabled			
		1	Enabled			
		2 to F	Reserved (Do not use.)			
	1	Selection of Active Mode for Safety Function B				
		0	Disabled			
		1	Enabled			
		2 to F	Reserved (Do not use.)			
	2	Reserved (Do not change.)				
	3	Reserved (Do not change.)				

Note 1. Active Mode Function cannot be used when the following safety functions have been selected.

- Safe BaseBlock Function (SBB function)
- The Safely Limited Speed with Delay Function (SLS-D function)
- No safety function.

For details on selecting the safety functions, refer to *6.2.1 Selecting a Safety Function*.

2. There are some limitations when Active Mode Function is used together with the utility functions.
For details, refer to *10.6 Related SERVOPACK Functions*.

10.4 Returning Method

10.4.1 Returning Conditions

When the motor stops due to the operation of Active Mode Function, Active Mode Function can be canceled to return to the normal operation when all of the following conditions are met.

- The corresponding Safety Request Input Signal must be ON.
- A period of time greater than the value set as the Active Mode Hold Time (Pn625) must have elapsed.
- If the control mode is set to position control, the position error must be within the value set in Position Error Level for Releasing Active Mode (Pn626)
- If the control mode is set to speed control, the speed reference must be within the value set in Speed Reference Level for Releasing Active Mode (Pn628).

Examples of the returning method used for the different control modes of the SERVOPACK are shown below.

10.4.2 SERVOPACK for Use with Analog Voltage and Pulse Train Reference

(1) Speed Control Mode

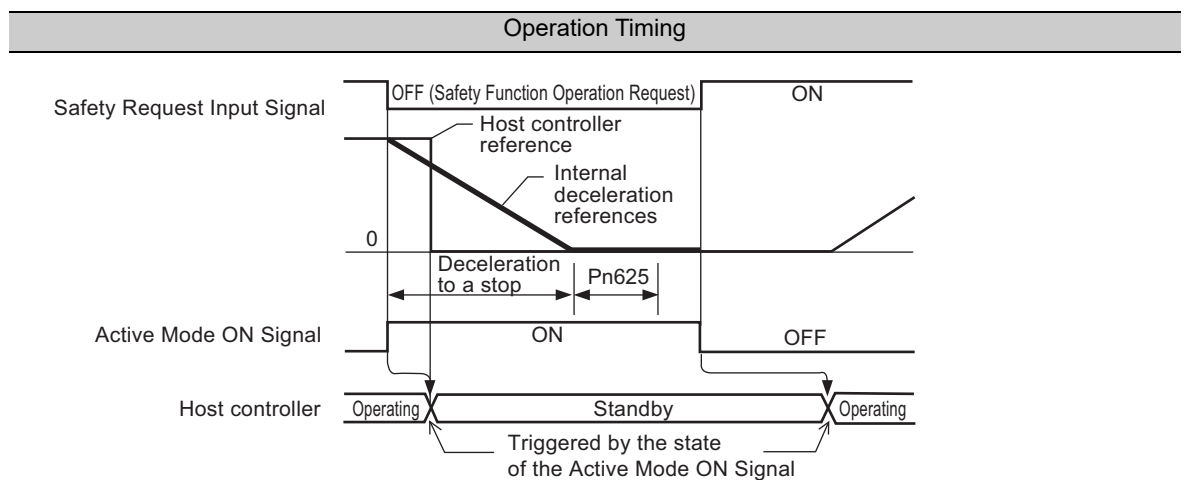

Pn625: Active Mode Hold Time

- Design the system in such a way that the host controller will stop the reference after detecting that the Active Mode ON Signal has turned ON.
- Design the system in such a way that the host controller will resume normal operations after detecting that the Active Mode ON Signal has turned OFF.

(2) Position Control Mode

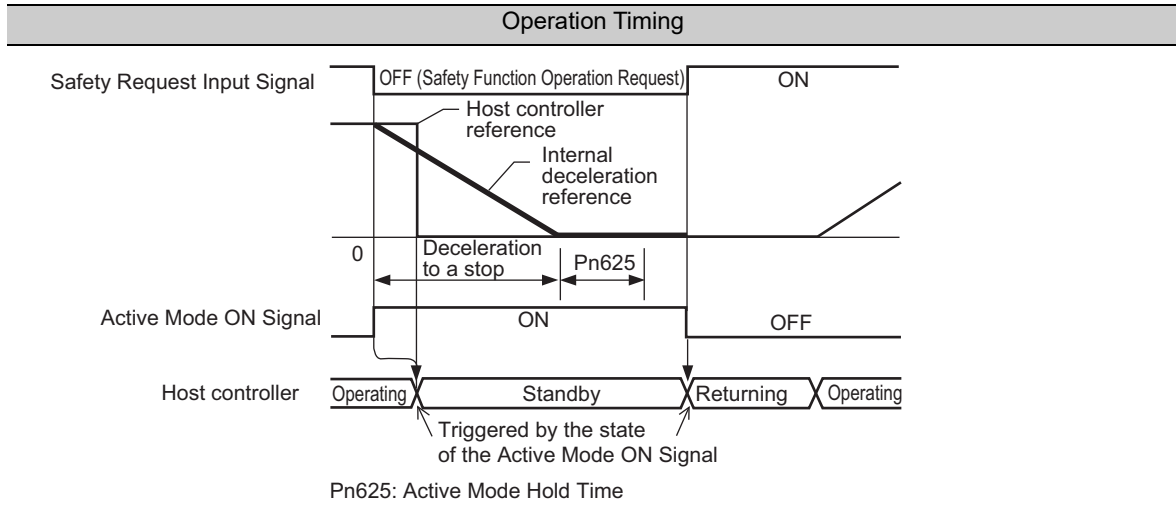

- Design the system in such a way that the host controller will stop the reference after detecting that the Active Mode ON Signal has turned ON.
- Design the system in such a way that the host controller will set the position information to the current position of the motor and resume normal operations after detecting that the Active Mode ON Signal has turned OFF.

- Note 1. After the Active Mode Function is activated, the motor stops at a position different from the reference position of the host controller, because the reference of the host controller will not be used. The motor will be stopped by the internal deceleration reference of the SERVOPACK.
2. When Active Mode Function starts, the position error becomes fixed. When the motor enters zero-clamp operation after a deceleration to a stop, the position error is cleared. After the position error has been cleared, it is calculated again according to the new reference that is input.

10.4.3 SERVOPACK for Use with MECHATROLINK-II Communications Reference

(1) Speed Control Mode

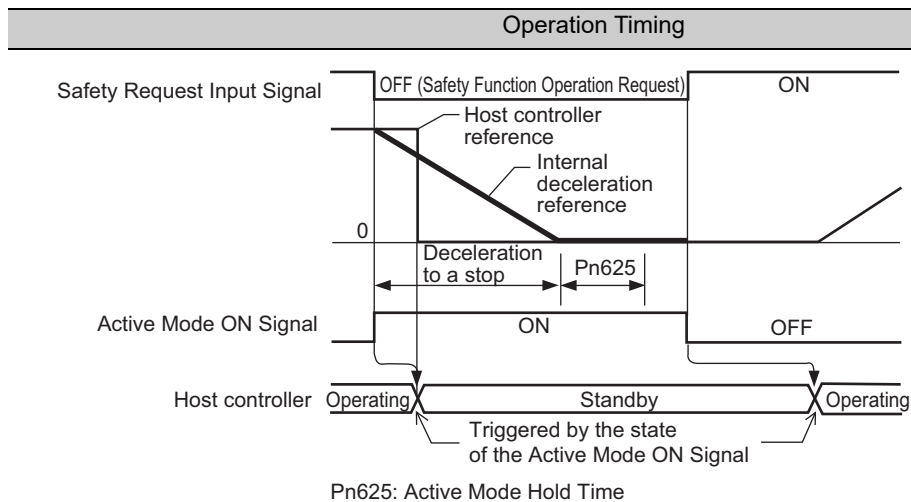

- Design the system in such a way that the host controller will send a HOLD, NOP, or SMON command after detecting that the Active Mode ON Signal has turned ON, and then the host controller will be placed on standby.
- Design the system in such a way that the host controller will resume normal operations after detecting that the Active Mode ON Signal has turned OFF.

For details on the MECHATROLINK-II communications commands, refer to the *Σ-V Series/DC Power Input Σ-V Series/Σ-V Series for Large-Capacity Models User's Manual MECHATROLINK-II Command* or the *Σ-7 Series MECHATROLINK-II Communications Commands Manual*.

(2) Position Control Mode

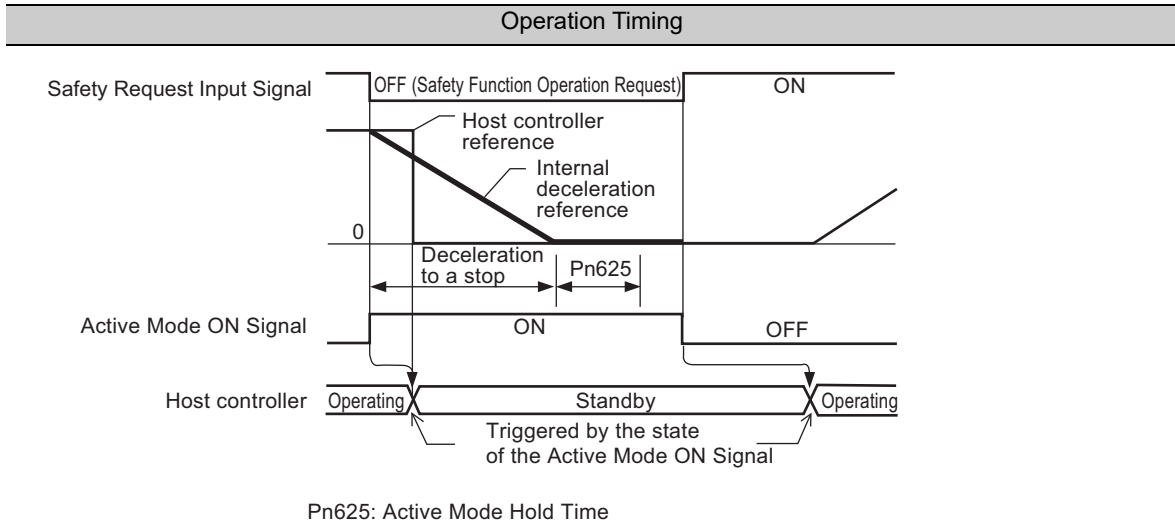

- Design the system in such a way that the host controller will do one of the following procedures after detecting that the Active Mode ON Signal has turned ON, and then the host controller will be placed on standby.
 - If an INTERPOLATE command is being executed, the host controller cancels the TPOS (target position) of the INTERPOLATE command or sends a non-motion command (NOP or SMON).
 - If a POSING, FEED, EX_POSING, or ZRET command is being executed, the host controller sends a HOLD command.
- Design the system in such a way that the host controller will resume normal operations after detecting that the Active Mode ON Signal has turned OFF.

[Related Motion Commands]
 INTERPOLATE
 POSING
 FEED
 LATCH
 EX_POSING
 ZRET

For details on the MECHATROLINK-II communications commands, refer to the *Σ-V Series/DC Power Input Σ-V Series/Σ-V Series for Large-Capacity Models User's Manual MECHATROLINK-II Command* or the *Σ-7 Series MECHATROLINK-II Communications Command Manual*.

10.4.4 SERVOPACK for Use with MECHATROLINK-III Communications Reference

(1) Speed Control Mode

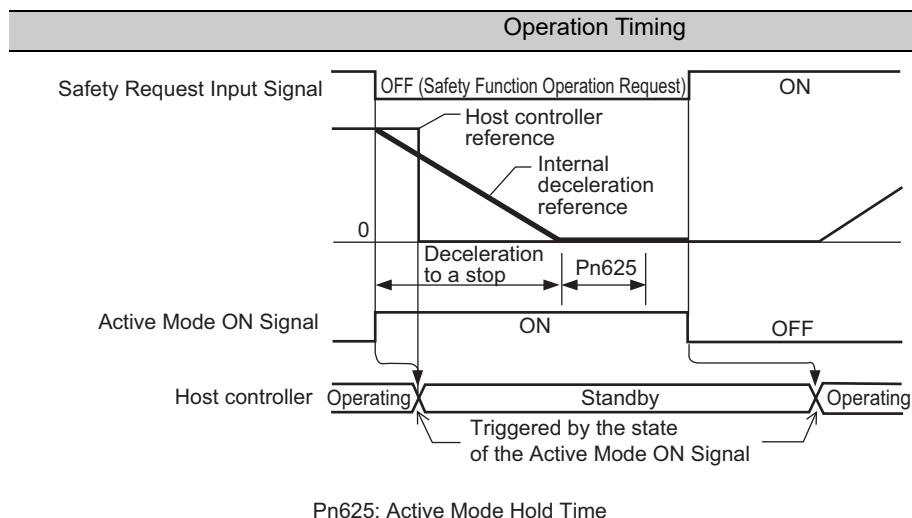

- Design the system in such a way that the host controller will do the following procedure after detecting that the Active Mode ON Signal has turned ON while the speed is controlled with a VELCTRL command. The host controller cancels the VELCTRL command, and then the controller is placed on standby. A VELCTRL command can be canceled by setting the CMD_CANCEL control bit in the SVCMD_CTRL field to 1.
- Design the system in such a way that the host controller will resume normal operations after detecting that the Active Mode ON Signal has turned OFF.

For details on the MECHATROLINK-III communications commands, refer to the *Σ-V Series/DC Power Input Σ-V Series/Σ-V Series for Large-Capacity Models User's Manual MECHATROLINK-III Command* or the *Σ-7 Series MECHATROLINK-III Standard Profile Command Manual*.

(2) Position Control Mode

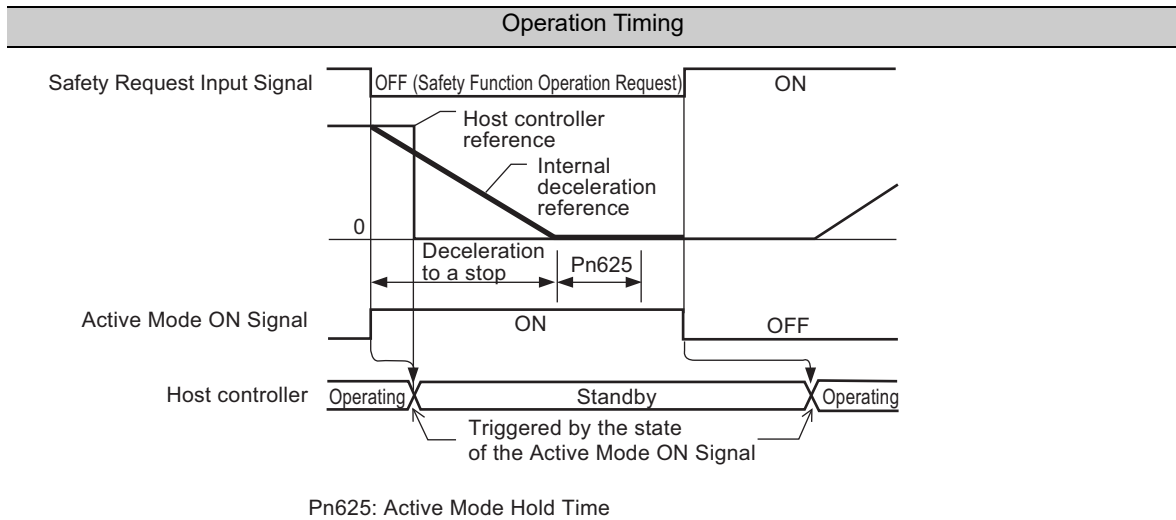

- Design the system in such a way that the host controller will do the following procedure after detecting that the Active Mode ON Signal has turned ON, and then the host controller will be placed on standby.
 - If an INTERPOLATE command is being executed, the host controller cancels the TPOS (target position) of the INTERPOLATE command or sends a non-motion command (NOP or SMON).
 - If a POSING, FEED, EX_POSING, EX_FEED, or a ZRET command is being executed, the host controller cancels the command. Any of these commands can be canceled by setting the CMD_CANCEL control bit in the SVCMD_CTRL field to 1.
- Design the system in such a way that the host controller will resume normal operations after detecting that the Active Mode ON Signal has turned OFF.

[Related Motion Command]
 INTERPOLATE
 POSING
 FEED
 EX_POSING
 EX_FEED
 ZRET

For details on the MECHATROLINK-III communications commands, refer to the *Σ-V Series/DC Power Input Σ-V Series/Σ-V Series for Large-Capacity Models User's Manual MECHATROLINK-III Command* or the *Σ-7 Series MECHATROLINK-III Standard Profile Command Manual*.

10.4.5 SERVOPACK for Use with MECHATROLINK-4 Communications Reference

(1) Speed Control Mode

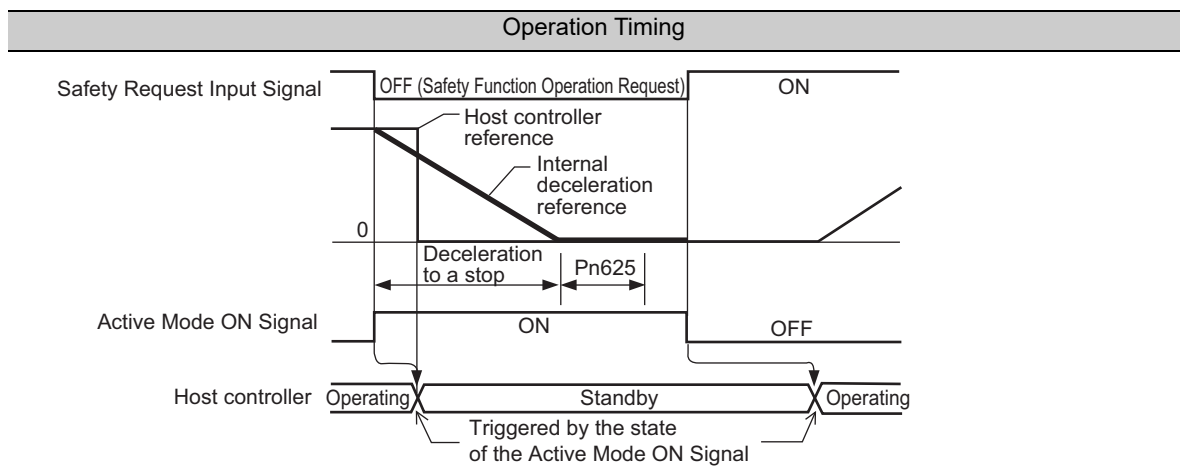

Pn625: Active Mode Hold Time

- Design the system in such a way that the host controller will do the following procedure after detecting that the Active Mode ON Signal has turned ON while the speed is controlled with a VELCTRL or CF_VELCTRL command.
The host controller cancels the VELCTRL or CF_VELCTRL command, and then the controller is placed on standby. A VELCTRL or CF_VELCTRL command can be canceled by setting the CMD_CANCEL control bit in the SVCMD_CTRL field to 1.
- Design the system in such a way that the host controller will resume normal operations after detecting that the Active Mode ON Signal has turned OFF.

For details on the MECHATROLINK-4 communications command, refer to the *Σ-7 Series MECHATROLINK-4 Standard Servo Profile Command Manual*.

(2) Position Control Mode

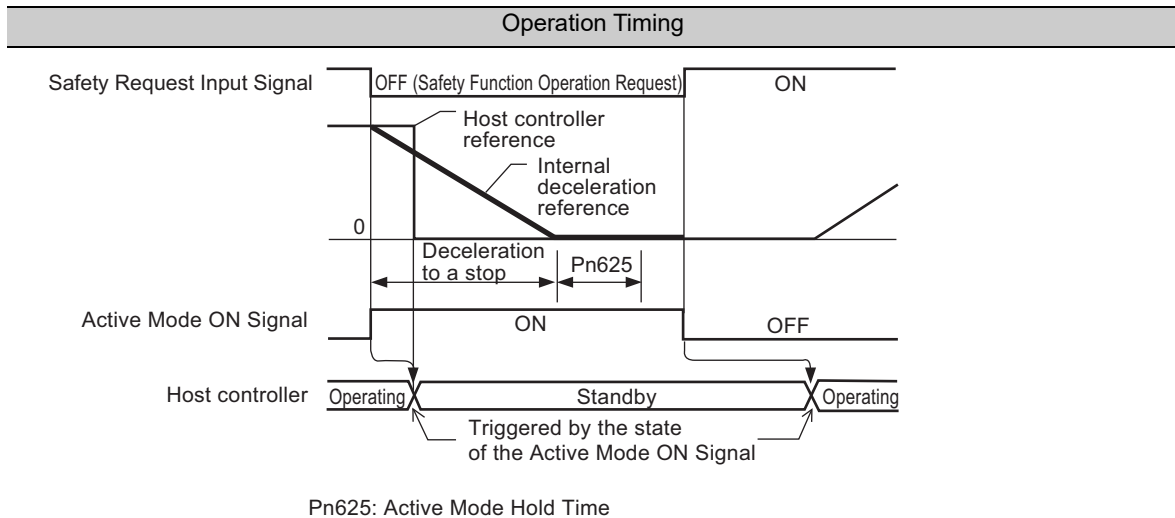

- Design the system in such a way that the host controller will do the following procedure after detecting that the Active Mode ON Signal has turned ON, and then the host controller will be placed on standby.
 - If an INTERPOLATE command is being executed, the host controller cancels the TPOS (target position) of the INTERPOLATE command or sends a non-motion command (NOP or SMON).
 - If a POSING, FEED, EX_POSING, EX_FEED, ZRET, or a CF_POSCTRL command is being executed, the host controller cancels the command. Any of these commands can be canceled by setting the CMD_CANCEL control bit in the SVCMD_CTRL field to 1.
- Design the system in such a way that the host controller will resume normal operations after detecting that the Active Mode ON Signal has turned OFF.

[Related Motion Command]
 INTERPOLATE
 POSING
 FEED
 EX_POSING
 EX_FEED
 ZRET
 CF_POSCTRL

For details on the MECHATROLINK-4 communications command, refer to the Σ -7 Series MECHATROLINK-4 Standard Servo Profile Command Manual.

10.4.6 SERVOPACK for Use with Command Option Module

The returning method from Active Mode Function depends on the Command Option Module that is connected. Refer to the manual of the corresponding Command Option Module.

10.5 Exceptional Operation

■ After Resetting the System

After the system is reset in Active Mode Function, Active Mode Function stops and the servo system is restarted.

■ While Recalculating Parameters

When parameters are being recalculated in Active Mode Function, Active Mode Function stops.

For SERVOPACKs with the MECHATROLINK-III communications reference or the MECHATROLINK-4 communications reference, however, a command warning will be issued and parameters will not be recalculated if recalculation of parameters is attempted with the CONFIG command during a servo ON state. If so, the Active Mode Function will remain active.

10.6 Related SERVOPACK Functions

The SERVOPACK functions related to the operation of the Active Mode Function are described below. For details, refer to the manual for your SERVOPACK.

- Utility functions
- Overtravel
- Servo ON command
- Zero-clamp function
- Speed feedforward function
- Torque feedforward function

10.6.1 Utility Functions

The following restriction are applied when Active Mode Function is used together with the utility functions.

Function No.	Function	Using Active Mode Function when Utility Functions Enabled	Using Utility Functions when Active Mode Function Enabled
Fn002	Jog Operation	Not possible	Not possible
Fn003	Origin Search		
Fn004	Program Jog Operation	Possible	
Fn005	Initializing Parameter Settings	Not possible	
Fn008	Absolute Encoder Multiturn Reset and Encoder Alarm Reset		
Fn009	Automatic Tuning of Analog (Speed, Torque) Reference Offset		
Fn00E	Automatic Offset-signal Adjustment of the Motor Current Detection Signal		
Fn013	Multiturn Limit Value Setting Change When a Multiturn Limit Disagreement Alarm Occurs		
Fn020	Origin Setting		
Fn030	Software Reset		
Fn041	Safety-related Module Parameter Setting		
Fn042	Safety-related Servo Parameter Updating		
Fn043	Safety Option Module Initializing Parameter Setting		
Fn044	Safety Option Module Setup Alarm Clear		
Fn080	Polarity Detection	Possible	
Fn201	Advanced Autotuning		
Fn202	Advanced Autotuning by Reference		
Fn203	One-parameter Tuning		
Fn204	Anti-resonance Control Adjustment Function		
Fn205	Vibration Suppression Function		
Fn206	EasyFFT		

10.6.2 Overtravel

If the overtravel function is operated in Active Mode Function, the SERVOPACK operations change as follows:

- The internal deceleration reference of Active Mode Function is stopped and the overtravel function is used to slow the motor.
The motor stop method depends on the overtravel function of the corresponding SERVOPACK.
- After stopping the motor, Active Mode Function cannot be canceled until the time period set in Pn625 has elapsed.

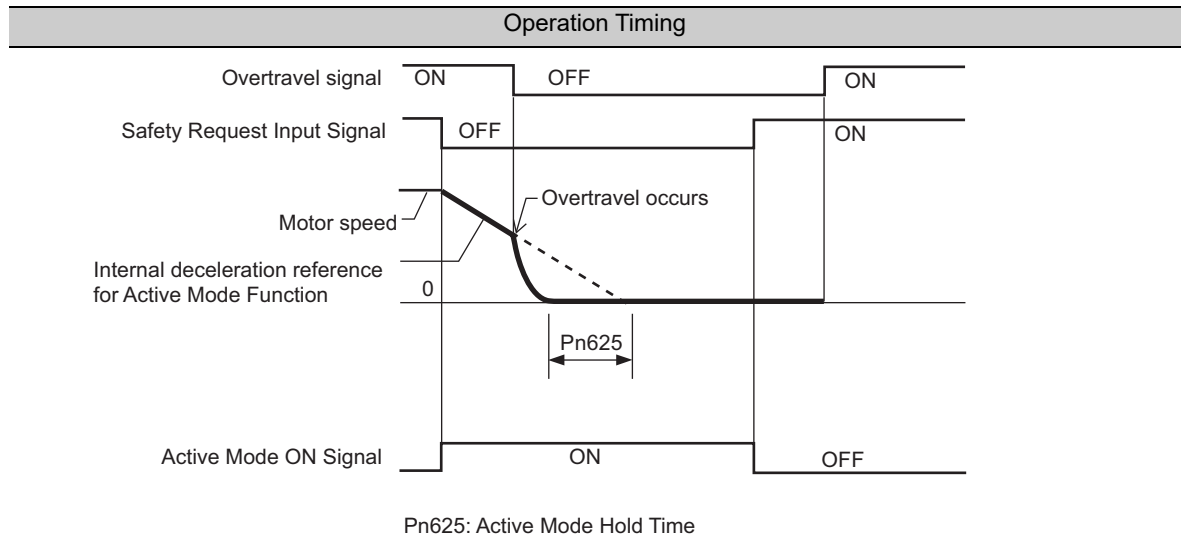

10.6.3 Servo ON Command

Active Mode Function stops when the Servo ON command is cleared.

10.6.4 Zero-clamp Function

The zero-clamp function does not operate in Active Mode Function.

Note: Only available for the analog voltage and pulse train reference model.

10.6.5 Speed Feedforward Function

The speed feedforward function does not operate in Active Mode Function.

10.6.6 Torque Feedforward Function

The torque feedforward function does not operate in Active Mode Function.

Troubleshooting

This chapter describes the alarms that can occur in the Safety Module and the methods of clearing these alarms. For details on the alarms that occur in the SERVOPACK and the methods of clearing the alarms, refer to the manual of your SERVOPACK.

11.1 List of Alarms	11-2
11.2 Troubleshooting of Alarms	11-3

11.1 List of Alarms

A list of alarms occurring in the Safety Module is shown below.

Alarm Code	Alarm Name	Alarm Details	Alarm Reset
A.E71	Safety Option Module Detection Failure	The Safety Option Module could not be detected.	N/A
A.E74	Safety Option Module Nonsupport	A Safety Option Module that is not supported by the SERVOPACK has been connected.	N/A
A.E81	Safety Option Module Unmatch	A Safety Option Module different from the one used before has been connected.	N/A
A.EB0	Safety Module: System Malfunction	An error occurred in the CPU of the Safety Module, or in a peripheral circuit.	N/A
A.EB2	Safety Module: Parameter Setting Error	An error occurred in a Safety Module parameter.	Available
A.EB3	HWBB Circuit Malfunction	An error occurred in the HWBB circuit of the SERVOPACK.	N/A
A.EB4	Safety Module: Feedback Data Malfunction	The feedback data is incorrect. (The output data of encoder pulse is incorrect.)	N/A
A.EB5	Safety Module: Timing Error of Safety Request Input Signal A	The ON/OFF timing of Safety Request Input Signals A1 and A2 does not match the specified time period.	N/A
A.EB6	Safety Module: Timing Error of Safety Request Input Signal B	The ON/OFF timing of Safety Request Input Signals B1 and B2 does not match the specified time period.	N/A
A.EB7	Safety Module: Safety Function A Monitoring Alarm	The motor speed has exceeded the monitoring speed set for Safety Function A. Alternatively, the distance that the motor moved has exceeded the distance for monitoring set for Safety Function A.	Available
A.EB8	Safety Module: Safety Function B Monitoring Alarm	The motor speed has exceeded the monitoring speed set for Safety Function B. Alternatively, the distance that the motor moved has exceeded the distance for monitoring set for Safety Function B.	Available
A.EB9	Safety Module: Parameter Change Alarm	A Safety Module parameter for which the power must be turned OFF and ON again to enable the settings was changed.	Available
A.EC0	Safety Module: Confirmation Alarm	A SERVOPACK different from the one used before has been connected. Alternatively, the Safety Module parameters were initialized.	Available
A.EC1	Safety-related Servo Parameter Unmatch Alarm	The settings of a safety-related servo parameter and the corresponding SERVOPACK parameter do not match.	Available
A.EC2	Active Mode Parameter Setting Error	A safety function that cannot be used together with the Active Mode Function has been selected.	Available

Note: The method of stopping the Servomotor when an alarm occurs depends on the setting of Pn001.0. The stop method in the factory settings is for using the DB. For details, refer to the manual for your SERVOPACK.

11.2 Troubleshooting of Alarms

Refer to the following table to identify the cause of an alarm and the action to be taken. Contact your Yaskawa representative if the problem cannot be solved by the described corrective action.

Alarm No.	Alarm Name	Cause	Investigative Action	Corrective Action
A.E71	Safety Option Module Detection Failure	Faulty connection between the SERVO-PACK and Safety Option Module.	Check the connection between the SERVO-PACK and Safety Option Module.	Reconnect the Safety Option Module.
		The Safety Option Module was removed.	—	Execute Fn014 (Resetting Configuration Error in Option Modules), and turn the power OFF and ON again.
		A fault occurred in the Safety Option Module.	—	Replace the Safety Option Module.
		A fault occurred in the SERVOPACK.	—	Replace the SERVO-PACK.
A.E74	Safety Option Module Nonsupport	A safety function jumper connector is connected to CN8.	Make sure that the safety function jumper connector is not connected to CN8 in the SERVO-PACK.	Remove the safety function jumper connector that is connected to CN8 in the SERVOPACK.
		A Safety Option Module that is not supported by the SERVOPACK has been connected.	<ul style="list-style-type: none"> Check the model of the Safety Option Module. Check for models of the Safety Option Module that are supported by the SERVOPACK. 	<ul style="list-style-type: none"> Install a Safety Option Module that is supported by the SERVOPACK. Replace the Safety Option Module. Replace the SERVOPACK.
		The power was turned ON without connecting the encoder.	Check the encoder connection.	Connect an encoder.
		An error occurred in the system of the Safety Option Module.	—	Replace the Safety Option Module.
A.E81	Safety Option Module Unmatch	A Safety Option Module different from the one used before has been connected.	Check the model of the Safety Option Module.	<ul style="list-style-type: none"> Execute Fn014 (Resetting Configuration Error in Option Modules), and turn the power OFF and ON again. Install the Safety Option Module that was connected before.

(cont'd)

Alarm No.	Alarm Name	Cause	Investigative Action	Corrective Action
A.EB0	Safety Module: System Malfunction	An error occurred in the system of the Safety Module.	—	<ul style="list-style-type: none"> Restart the system. Make improvements in the EMC installation environment. Replace the Safety Module. Replace the SERVO-PACK.
		The following alarms are occurred. <ul style="list-style-type: none"> Encoder Communications Error (A.C90) Encoder Communications Position Data Acceleration Rate Error (A.C91) Encoder Communications Timer Error (A.C92) 	Refer to the manual for your SERVOPACK.	
A.EB2	Safety Module: Parameter Setting Error	The settings of the safety functions do not conform to the settings of the test without motor function.	Check the set values of Pc00 and Pn00C.	When the safety functions are used: Set Pn00C.0 (Selection of Test without a Motor) to 0. When the test without motor function is used: Set digit 1 and digit 2 of Pc00 (Safety Function Selection Switch) to 0.
		The settings of the safety functions do not conform to the settings of the external encoder usage method.	Check the set values of Pc00 and Pc5A.	When the safety functions are used: <ul style="list-style-type: none"> Remove the external encoder. Set Pn002.3 (External Encoder Usage) to 0, and then execute Fn042 (Safety-related Servo Parameter Updating). Turn the control power OFF and then ON again, and confirm that Pc5A.0 = 0 (External Encoder Setting = Does not use the external encoder). When an external encoder is used: Set digit 1 and digit 2 of Pc00 (Safety Function Selection Switch) to 0.
		The set value of deceleration waiting time does not conform to the set value of deceleration monitoring time.	Check the set values of Pc10 and Pc11, and also those of Pc20 and Pc21.	Set the appropriate values.

(cont'd)

Alarm No.	Alarm Name	Cause	Investigative Action	Corrective Action
A.EB2	Safety Module: Parameter Setting Error (cont'd)	The set value of deceleration waiting monitoring speed does not conform to the maximum speed of the rotational motor or linear motor.	Check the set values of Pc12 and Pc62, and also those of Pc22 and Pc62.	Set the appropriate values.
		The set value of deceleration waiting monitoring speed does not conform to the set value of constant monitoring speed.	Check the set values of Pc12 and Pc14, and also those of Pc22 and Pc24.	Set the appropriate values.
		The set value of encoder output pulses does not conform to the rotational motor that is being used.	Check the model of the motor that is being used and also the set value of Pn212.	Set the appropriate values.
		The set values of encoder output resolution, Motor Max. Speed, and Liner Scale Pitch do not conform to the linear motor that is being used.	Check the set values of Pc62, Pc63, and Pn281.	Set the appropriate values.
		An error occurred in a Safety Module parameter.	—	<ul style="list-style-type: none"> Execute Fn043 (Safety Option Module Initializing Parameter Setting). Replace the Safety Module.
A.EB3	HWBB Circuit Malfunction	An error occurred in the HWBB circuit of the SERVOPACK.	Make sure that the safety function jumper connector is not connected to CN8 of the SERVOPACK.	Remove the safety function jumper connector that is connected to CN8 of the SERVOPACK.
			—	<ul style="list-style-type: none"> Restart the system. Replace the SERVOPACK. Replace the Safety Module.
A.EB4	Safety Module: Feedback Data Malfunction	An error occurred in the position data of the motor.	—	<ul style="list-style-type: none"> Restart the system. Remove the Safety Module and then install it again. Replace the SERVOPACK. Replace the Safety Module.
A.EB5	Safety Module: Timing Error of Safety Request Input Signal A	When either Safety Request Input Signal A1 or A2 was turned OFF, the other signal did not turn OFF within 10 seconds.	<ul style="list-style-type: none"> Check the state of the I/O signal corresponding to Un016. Check the wiring. Check the waveform of the input signal with measuring device such as an oscilloscope. 	<ul style="list-style-type: none"> Correct the wiring. Make improvements in the EMC installation environment. Restart the system. Replace the Safety Module.
		When either Safety Request Input Signal A1 or A2 was turned ON, the other signal did not turn ON within 10 seconds.		

(cont'd)

Alarm No.	Alarm Name	Cause	Investigative Action	Corrective Action
A.EB6	Safety Module: Timing Error of Safety Request Input Signal B	When either Safety Request Input Signal B1 or B2 was turned OFF, the other signal did not turn OFF within 10 seconds.	<ul style="list-style-type: none"> • Check the state of the I/O signal corresponding to Un016. • Check the wiring. • Check the waveform of the input signal with measuring device such as an oscilloscope. 	<ul style="list-style-type: none"> • Correct the wiring. • Make improvements in the EMC installation environment. • Restart the system. • Replace the Safety Module.
		When either Safety Request Input Signal B1 or B2 was turned ON, the other signal did not turn ON within 10 seconds.		
A.EB7	Safety Module: Safety Function A Monitoring Alarm	When SBB-D, SPM-D, or SLS-D was selected as Safety Function A, the motor speed exceeded the monitoring speed set for Safety Function A.	—	<ul style="list-style-type: none"> • Correct the deceleration reference. • Correct the monitoring speed.
		When SPM-D was selected as Safety Function A, the distance that the motor moved exceeded the distance for monitoring set for Safety Function A.	—	<ul style="list-style-type: none"> • Correct the position reference. • Correct the distance for monitoring.
A.EB8	Safety Module: Safety Function B Monitoring Alarm	When SBB-D, SPM-D, or SLS-D was selected as Safety Function B, the motor speed exceeded the monitoring speed set for Safety Function B.	—	<ul style="list-style-type: none"> • Correct the deceleration reference. • Correct the monitoring speed.
		When SPM-D was selected as Safety Function B, the distance that the motor moved exceeded the distance for monitoring set for Safety Function B.	—	<ul style="list-style-type: none"> • Correct the position reference. • Correct the distance for monitoring.
A.EB9	Safety Module: Parameter Change Alarm	A Safety-related Module Parameter was changed.	—	<ul style="list-style-type: none"> • Restart the system. • Recalculate the parameters.
		Fn042 (Safety-related Servo Parameter Updating) was executed.		
		Fn043 (Safety Option Module Initializing Parameter Setting) was executed.		
A.EC0	Safety Module: Confirmation Alarm	Fn043 (Safety Option Module Initializing Parameter Setting) was executed.	—	Execute Fn044 (Safety Option Module Setup Alarm Clear). Then, reset the alarm.
		A different Safety Module was connected to the SERVOPACK.		

(cont'd)

Alarm No.	Alarm Name	Cause	Investigative Action	Corrective Action
A.EC1	Safety-related Servo Parameter Unmatch Alarm	The settings of a safety-related servo parameter maintained in the Safety Module do not match the settings of the corresponding SERVOPACK parameter.	<ul style="list-style-type: none"> • Check the safety-related servo parameters maintained in the Safety Module. • Check the SERVOPACK parameters related to the safety functions. 	<ul style="list-style-type: none"> • Execute Fn042 (Safety-related Servo Parameter Updating). • Match the settings of the SERVOPACK parameter with the settings of the corresponding safety-related servo parameter maintained in the Safety Module.
		Fn043 (Safety Option Module Initializing Parameter Setting) was executed.		
		The motor, encoder, or linear scale connected to the SERVOPACK was changed.	Check the encoder connection.	
A.EC2	Active Mode Parameter Setting Error	A safety function that cannot be used together with the Active Mode Function has been selected.	Check the set values of Pc00 and Pn621.	<p>When the Active Mode Function is used: Select safety functions that can be used together with the Active Mode Function for Safety Function A and Safety Function B.</p> <p>When the Active Mode Function is not used: Disable the Active Mode Function. (For details, refer to 10.3.)</p>

Appendix

This chapter describes three parameters and also devices that can be used with the Safety Module. For the parameters of the SERVOPACK, refer to the manual for your SERVO-PACK.

12.1 Safety-related Module Parameters	12-2
12.2 Safety-related Servo Parameters	12-4
12.3 Parameters Related Active Mode Function	12-6
12.4 Device Combinations	12-8
12.4.1 SERVOPACKs	12-8
12.4.2 Servomotors	12-8
12.4.3 Serial Converter Units	12-13

12.1 Safety-related Module Parameters

This section contains a tables of Safety Module parameters.

Note: Do not change the following parameters from the factory settings.

- Reserved parameters
- Parameters not described in this manual

Parameter No.	Name	Setting Range	Units	Factory Setting	When Enabled	
Pc00	Safety Function Selection Switch	–	–	0002	After resetting the system	
		4th digit n. <input type="checkbox"/>	3rd digit <input type="checkbox"/>	2nd digit <input type="checkbox"/>	1st digit <input type="checkbox"/>	
		Safety Function A Selection				
		0	No safety function.			
		1	Safe BaseBlock Function (SBB function)			
		2	Safe BaseBlock with Delay Function (SBB-D function)			
		3	Safe Position Monitor with Delay Function (SPM-D function)			
		4	Safely Limited Speed with Delay Function (SLS-D function)			
		5 to F	Reserved (Do not use.)			
		Safety Function B Selection				
	0	No safety function.				
	1	Safe BaseBlock Function (SBB function)				
	2	Safe BaseBlock with Delay Function (SBB-D function)				
	3	Safe Position Monitor with Delay Function (SPM-D function)				
	4	Safely Limited Speed with Delay Function (SLS-D function)				
	5 to F	Reserved (Do not use.)				
	Reserved (Do not change.)					
	Apply Monitoring Speed Margin Selection					
	0	Applies the monitoring speed margin during deceleration monitoring and constant speed monitoring.				
	1	Applies the monitoring speed margin during deceleration monitoring only. The monitoring speed margin is not applied during constant speed monitoring.				
Pc01	EDM Signal Output Selection Switch	–	–	0011	After resetting the system	
		4th digit n. <input type="checkbox"/>	3rd digit <input type="checkbox"/>	2nd digit <input type="checkbox"/>	1st digit <input type="checkbox"/>	
		EDM Signal A Output Setting				
		0	The EDM-A signal turns ON while the safety function of Safety Function A is operating.			
		1	The EDM-A signal turns ON while Safety Function A is in the safe state.			
		2 to F	Reserved (Do not use.)			
		EDM Signal B Output Setting				
		0	The EDM-B signal turns ON while the Safety Function of safety function B is operating.			
		1	The EDM-B signal turns ON while Safety Function B is in the safe state.			
		2 to F	Reserved (Do not use.)			
	Reserved (Do not change.)					
	Reserved (Do not change.)					
Pc02 to Pc0F	Reserved (Do not change.)					

(cont'd)

Parameter No.	Name	Setting Range	Units	Factory Setting	When Enabled
Pc10	Deceleration Waiting Time A	0 to 10000	10 ms	0	After resetting the system
Pc11	Deceleration Monitoring Time A	0 to 10000	10 ms	500	After resetting the system
Pc12	Limited Speed A on Waiting for Deceleration	0 to 10000	Rotational motor: min^{-1} Linear motor: mm/s	0	After resetting the system
Pc13	Limited Distance A	1 to 65535	edge	10	After resetting the system
Pc14	Limited Constant Speed A	0 to 10000	Rotational motor: min^{-1} Linear motor: mm/s	0	After resetting the system
Pc15 to Pc1F	Reserved (Do not change.)				
Pc20	Deceleration Waiting Time B	0 to 10000	10 ms	0	After resetting the system
Pc21	Deceleration Monitoring Time B	0 to 10000	10 ms	500	After resetting the system
Pc22	Limited Speed B on Waiting for Deceleration	0 to 10000	Rotational motor: min^{-1} Linear motor: mm/s	0	After resetting the system
Pc23	Limited Distance B	1 to 65535	edge	10	After resetting the system
Pc24	Limited Constant Speed B	0 to 10000	Rotational motor: min^{-1} Linear motor: mm/s	0	After resetting the system
Pc25 to Pc4F	Reserved (Do not change.)				

12.2 Safety-related Servo Parameters

This section contains a tables of parameters.

Note: Do not change the following parameters from the factory settings.

- Reserved parameters
- Parameters not described in this manual

Parameter No.	Name	Setting Range	Units	Factory Setting	When Enabled						
Pc50	Motor Setting Switch	–	–	0000	After resetting the system						
	<p>4th digit 3rd digit 2nd digit 1st digit</p> <p>n. <input type="checkbox"/> <input type="checkbox"/> <input type="checkbox"/> <input type="checkbox"/></p> <p>Motor Type Setting</p> <table border="1"> <tr> <td>0</td> <td>Rotational motor</td> </tr> <tr> <td>1</td> <td>Linear motor</td> </tr> <tr> <td>2 to F</td> <td>Reserved (Do not use.)</td> </tr> </table> <p>Reserved (Do not change.)</p> <p>Reserved (Do not change.)</p> <p>Reserved (Do not change.)</p>					0	Rotational motor	1	Linear motor	2 to F	Reserved (Do not use.)
	0	Rotational motor									
	1	Linear motor									
	2 to F	Reserved (Do not use.)									
	Pc51	Function Setting Switch	–	–	0011	After resetting the system					
<p>4th digit 3rd digit 2nd digit 1st digit</p> <p>n. <input type="checkbox"/> <input type="checkbox"/> <input type="checkbox"/> <input type="checkbox"/></p> <p>Selection of Test without Motor</p> <table border="1"> <tr> <td>0</td> <td>Disabled</td> </tr> <tr> <td>1</td> <td>Enabled</td> </tr> <tr> <td>2 to F</td> <td>Reserved (Do not use.)</td> </tr> </table> <p>Reserved (Do not change.)</p> <p>Reserved (Do not change.)</p> <p>Reserved (Do not change.)</p>					0	Disabled	1	Enabled	2 to F	Reserved (Do not use.)	
0		Disabled									
1		Enabled									
2 to F		Reserved (Do not use.)									
Pc52 to Pc59		Reserved (Do not change.)									
Pc5A	Rotary Motor Setting Switch	–	–	0000	After resetting the system						
	<p>4th digit 3rd digit 2nd digit 1st digit</p> <p>n. <input type="checkbox"/> <input type="checkbox"/> <input type="checkbox"/> <input type="checkbox"/></p> <p>External Encoder Setting</p> <table border="1"> <tr> <td>0</td> <td>Does not use external encoder.</td> </tr> <tr> <td>1</td> <td>Uses external encoder.</td> </tr> <tr> <td>2 to F</td> <td>Reserved (Do not use.)</td> </tr> </table> <p>Reserved (Do not change.)</p> <p>Reserved (Do not change.)</p> <p>Reserved (Do not change.)</p>					0	Does not use external encoder.	1	Uses external encoder.	2 to F	Reserved (Do not use.)
	0	Does not use external encoder.									
	1	Uses external encoder.									
	2 to F	Reserved (Do not use.)									

(cont'd)

Parameter No.	Name	Setting Range	Units	Factory Setting	When Enabled
Pc5B to Pc5F	Reserved (Do not change.)				
Pc60	Encoder Resolution	–	bit	20	After resetting the system
Pc61	Encoder Output Pulses/ Encoder Output Resolution	–	Rotational motor: pulse/rev Linear motor: edge/pitch	2048	After resetting the system
Pc62	Motor Max. Speed	–	Rotational motor: min^{-1} Linear motor: mm/s	6000	After resetting the system
Pc63	Linear Scale Pitch	–	0.01 μm	0	After resetting the system
Pc64 to Pc6F	Reserved (Do not change.)				

12.3 Parameters Related Active Mode Function

Parameter No.	Name	Setting Range	Units	Factory Setting	When Enabled	
Pn518	Output Signal Selection 7	–	–	0000	After resetting the system or recalculating parameters	
	0	Active Mode ON Signal Mapping				
		0	Disabled			
		1	< Σ -V Series and Σ -7 Series Σ -7S> • Analog voltage and pulse train reference model: CN1-25(26) • M-II/-III/-4 communications reference model and command option attachable type: CN1-1(2) <Large-Capacity Σ -V Series> Analog voltage and pulse train reference model, M-II communications reference model, M-III communications reference model, and command option attachable type: CN1-25(26)			
		2	< Σ -V Series and Σ -7 Series Σ -7S> • Analog voltage and pulse train reference model: CN1-27(28) • M-II/-III/-4 communications reference model and command option attachable type: CN1-23(24) <Large-Capacity Σ -V Series> Analog voltage and pulse train reference model, M-II communications reference model, M-III communications reference model, and command option attachable type: CN1-27(28)			
	3	< Σ -V Series and Σ -7 Series Σ -7S> • Analog voltage and pulse train reference model: CN1-29(30) • M-II/-III/-4 communications reference model and command option attachable type: CN1-25(26) <Large-Capacity Σ -V Series> Analog voltage and pulse train reference model, M-II communications reference model, M-III communications reference model, and command option attachable type: CN1-29(30)				
	1	Reserved (Do not change.)				
	2	Reserved (Do not change.)				
	3	Reserved (Do not change.)				
	Pn621	Application Switch for Safety Function	–	–	0000	After resetting the system or recalculating parameters
0		Selection of Active Mode for Safety Function A				
		0	Disabled			
		1	Enabled			
		2 to F	Reserved (Do not use.)			
1		Selection of Active Mode for Safety Function B				
		0	Disabled			
		1	Enabled			
		2 to F	Reserved (Do not use.)			
2		Reserved (Do not change.)				
3	Reserved (Do not change.)					
Pn622	Constant of Deceleration for Safety Function A	1 to 30000	Rotational motor: min^{-1}/s Linear motor: mm/s^2	10000	Immediately	
Pn623	Constant of Deceleration for Safety Function B	1 to 30000	Rotational motor: min^{-1}/s Linear motor: mm/s^2	10000	Immediately	

(cont'd)

Parameter No.	Name	Setting Range	Units	Factory Setting	When Enabled
Pn624	Motor Stop Detection Level for Active Mode	0 to 10000	Rotational motor: min^{-1} Linear motor: mm/s	10	Immediately
Pn625	Active Mode Hold Time	0 to 10000	10 ms	100	Immediately
Pn626	Position Error Level for Releasing Active Mode	1 to 1073741823	1 Reference unit	100	Immediately
Pn628	Speed Reference Level for Releasing Active Mode	0 to 10000	Rotational motor: min^{-1} Linear motor: mm/s	10	Immediately

12.4 Device Combinations

Only the models of SERVOPACKs, rotational servomotors and serial converter units listed here can be used in combination with the Safety Module.

12.4.1 SERVOPACKs

SERVOPACK Models		
Analog voltage and pulse train reference model	Rotational motor	SGDV-□□□□01A SGDV-□□□□01B SGDV-COA□□□A
	Linear motor	SGDV-□□□□05A SGDV-□□□□05B
	Rotational/linear motor	SGD7S-□□□A00A
M-II communications reference model	Rotational motor	SGDV-□□□□11A SGDV-□□□□11B SGDV-COA□□□A
	Linear motor	SGDV-□□□□15A SGDV-□□□□15B
	Rotational/linear motor	SGD7S-□□□A10A
M-III communications reference model	Rotational motor	SGDV-□□□□21A SGDV-□□□□21B SGDV-COA□□□A
	Linear motor	SGDV-□□□□25A SGDV-□□□□25B
	Rotational/linear motor	SGD7S-□□□A20A
M-4 communications reference model	Rotational/linear motor	SGD7S-□□□A40A
Command option attachable type	Rotational motor	SGDV-□□□□E1A SGDV-COA□□□A
	Linear motor	SGDV-□□□□E5A

12.4.2 Servomotors

Rotational Servomotor Models	
SGMJV (Medium inertia, small capacity) 3000 min ⁻¹	SGMJV-A5A
	SGMJV-01A
	SGMJV-C2A
	SGMJV-02A
	SGMJV-04A
	SGMJV-06A
	SGMJV-08A
SGMAV (Low inertia, small capacity) 3000 min ⁻¹	SGMAV-A5A
	SGMAV-01A
	SGMAV-C2A
	SGMAV-02A
	SGMAV-04A
	SGMAV-06A
	SGMAV-08A
SGMAV-10A	

(cont'd)

Rotational Servomotor Models	
SGMPS (Medium inertia, small capacity, flat type) 3000 min ⁻¹	SGMPS-01A
	SGMPS-02A
	SGMPS-04A
	SGMPS-08A
	SGMPS-15A
SGMGV (Medium inertia, medium capacity) 1500 min ⁻¹	SGMGV-03A
	SGMGV-05A
	SGMGV-09A
	SGMGV-13A
	SGMGV-20A
	SGMGV-30A
	SGMGV-44A
	SGMGV-55A
	SGMGV-75A
	SGMGV-1AA
	SGMGV-1EA
	SGMGV-03D
	SGMGV-05D
	SGMGV-09D
	SGMGV-13D
	SGMGV-20D
	SGMGV-30D
	SGMGV-44D
	SGMGV-55D
	SGMGV-75D
SGMGV-1AD	
SGMGV-1ED	
SGMSV (Low inertia, medium capacity) 3000 min ⁻¹	SGMSV-10A
	SGMSV-15A
	SGMSV-20A
	SGMSV-25A
	SGMSV-30A
	SGMSV-40A
	SGMSV-50A
	SGMSV-70A
	SGMSV-10D
	SGMSV-15D
	SGMSV-20D
	SGMSV-25D
	SGMSV-30D
	SGMSV-40D
	SGMSV-50D

(cont'd)

Rotational Servomotor Models	
SGMVCV (Direct Drive, small capacity, coreless inner rotor)	SGMVCV-04B
	SGMVCV-10B
	SGMVCV-14B
	SGMVCV-08C
	SGMVCV-17C
	SGMVCV-25C
	SGMVCV-16D
	SGMVCV-35D
SGMCS (Direct Drive, small capacity, coreless inner rotor)	SGMCS-02B
	SGMCS-05B
	SGMCS-07B
	SGMCS-04C
	SGMCS-10C
	SGMCS-14C
	SGMCS-08D
	SGMCS-17D
	SGMCS-25D
	SGMCS-16E
SGMCS-35E	
SGMCS (Direct Drive, medium capacity, inner rotor with core)	SGMCS-45M
	SGMCS-80M
	SGMCS-1AM
	SGMCS-80N
	SGMCS-1EN
	SGMCS-2ZN
SGMVV (Low inertia, large capacity) 800 min ⁻¹ , 1500 min ⁻¹	SGMVV-2BA
	SGMVV-3ZA
	SGMVV-3GA
	SGMVV-2BD
	SGMVV-3ZD
	SGMVV-3GD
	SGMVV-4ED
	SGMVV-5ED
SGMMV (Medium inertia, ultra-small capacity) 6000 min ⁻¹	SGMMV-A1A
	SGMMV-A2A
	SGMMV-A3A
SGM7J (Medium inertia, small capacity) 6000 min ⁻¹	SGM7J-A5A
	SGM7J-01A
	SGM7J-C2A
	SGM7J-02A
	SGM7J-04A
	SGM7J-06A
SGM7J-08A	

(cont'd)

Rotational Servomotor Models	
SGM7A (Low inertia, small capacity) 6000 min ⁻¹	SGM7A-A5A
	SGM7A-01A
	SGM7A-C2A
	SGM7A-02A
	SGM7A-04A
	SGM7A-06A
	SGM7A-08A
	SGM7A-10A
	SGM7A-15A
	SGM7A-20A
	SGM7A-25A
	SGM7A-30A
	SGM7A-40A
	SGM7A-50A
SGM7A-70A	
SGM7P (Medium inertia, small capacity) 6000 min ⁻¹	SGM7P-01A
	SGM7P-02A
	SGM7P-04A
	SGM7P-08A
	SGM7P-15A
SGM7G (Medium inertia, medium capacity) 3000 min ⁻¹	SGM7G-03A
	SGM7G-05A
	SGM7G-09A
	SGM7G-13A
	SGM7G-20A
	SGM7G-30A
	SGM7G-44A
	SGM7G-55A
	SGM7G-75A
	SGM7G-1AA
SGM7G-1EA	

(cont'd)

Rotational Servomotor Models	
SGM7D (Direct Drive, outer rotor with core)	SGM7D-30F
	SGM7D-58F
	SGM7D-90F
	SGM7D-1AF
	SGM7D-01G
	SGM7D-05G
	SGM7D-08G
	SGM7D-18G
	SGM7D-24G
	SGM7D-34G
	SGM7D-45G
	SGM7D-03H
	SGM7D-28I
	SGM7D-70I
	SGM7D-1ZI
	SGM7D-1CI
	SGM7D-2BI
	SGM7D-2DI
	SGM7D-06J
	SGM7D-09J
	SGM7D-18J
	SGM7D-20J
	SGM7D-38J
	SGM7D-02K
	SGM7D-06K
	SGM7D-08K
	SGM7D-06L
	SGM7D-12L
	SGM7D-30L
	SGM7E (Direct Drive, small capacity, coreless inner rotor)
SGM7E-05B	
SGM7E-07B	
SGM7E-04C	
SGM7E-10C	
SGM7E-14C	
SGM7E-08D	
SGM7E-17D	
SGM7E-25D	
SGM7E-16E	
SGM7E-35E	

(cont'd)

Rotational Servomotor Models	
SGM7F (Direct Drive, small capacity, inner rotor with core)	SGM7F-02A
	SGM7F-05A
	SGM7F-04B
	SGM7F-10B
	SGM7F-14B
	SGM7F-08C
	SGM7F-17C
	SGM7F-25C
	SGM7F-16D
	SGM7F-35D
SGM7F (Direct Drive, medium capacity, inner rotor with core)	SGM7F-45M
	SGM7F-80M
	SGM7F-80N
	SGM7F-1AM
	SGM7F-1EN
	SGM7F-2ZN

Note: For details on rotational servomotors, refer to the Σ -V Series or Large-Capacity Σ -V Series Product Catalog or the Σ -7 Series Product Catalog.

Any model of linear servomotor can be used with the Safety Module. However, be sure to connect the linear servomotor to the serial converter unit shown in 12.4.3 *Serial Converter Units*. This servo system does not conform to safety standards if the specified serial converter unit is not connected.

12.4.3 Serial Converter Units

Serial Converter Unit Model	
Without hall sensor, by Heidenhain	JZDP-D003-□□□-E
	JZDP-G003-□□□-E
	JZDP-H003-□□□
	JZDP-J003-□□□
Without hall sensor, by Renishaw	JZDP-D005-□□□-E
	JZDP-G005-□□□-E
	JZDP-H005-□□□
	JZDP-J005-□□□
With hall sensor, by Heidenhain	JZDP-D006-□□□-E
	JZDP-G006-□□□-E
	JZDP-H006-□□□
	JZDP-J006-□□□
With hall sensor, by Renishaw	JZDP-D008-□□□-E
	JZDP-G008-□□□-E
	JZDP-H008-□□□
	JZDP-J008-□□□

Note: For details on serial converter units, refer to the Σ -V Series or Large-Capacity Σ -V Series Product Catalog or the Σ -7 Series Product Catalog.

Index

A

Active Mode Function	10-2
basic functions	10-2
exceptional operation	10-21
related SERVOPACK functions	10-22
returning method	10-13
settings	10-12
Active Mode Hold Time	10-3
Active Mode Reference Speed	9-8
application example of safety functions	6-32
checking the operation of safety functions	6-34
connection example	6-32
operation example	6-33

B

basic settings required before starting operation	5-8
---	-----

C

checking the operation	5-9
constant-speed monitoring	xxiii, 6-27, 6-29

D

deceleration monitoring	xxiii, 6-18, 6-22, 6-26
device combinations	12-8
displaying the status on the panel	9-4
deceleration monitoring	9-4
safe (HWBB) state	9-4
safe state	9-4

E

EMC directive	3-2
EMC installation conditions	3-6
analog voltage and pulse train reference model	3-7, 3-38, 3-46
command option attachable type	3-31, 3-44
M-4 communications reference model	3-49
M-II communications reference model	3-15, 3-40
M-III communications reference model	3-23, 3-42, 3-47, 3-48
EU Directives	xix
External Device Monitor Output Signal A	4-4, 4-6
External Device Monitor Output Signal B	4-4, 4-6
External Device Monitor Output Signals	6-7
output conditions	6-7
output delay time	6-9
selecting output conditions	6-8

F

Fn040	8-3
Fn041	8-5
Fn042	8-8
Fn043	8-12
Fn044	8-14

H

harmonized standards	3-2
installation conditions	3-2

I

I/O connector for Safety Function A	4-4
I/O connector for Safety Function B	4-4

input circuit	4-5
connections	4-5
electrical specifications	4-5
input signal for Safety Function A	4-4
Safety Request Input Signal A1	4-4
Safety Request Input Signal A2	4-4
input signal for Safety Function B	4-4
Safety Request Input Signal B1	4-4
Safety Request Input Signal B2	4-4
internal deceleration references	10-3

L

limitations on lower limit of encoder output pulses	5-4
linear servomotors	5-6
rotational servomotors	5-4
limitations on the use of an external encoder	5-7
limitations on the use of the test without motor function	5-7
list	
alarms	11-2
monitor modes	9-2
utility functions	8-2
low voltage directive	3-2

M

model designation	1-3
monitoring	9-5
digital operator	9-5
network	9-9
panel operator	9-5
monitoring Active Mode Function	10-6
Active Mode ON Signal	10-6
MECHATROLINK-4 I/O signal monitor (SVCMD_IN)	
field	10-10
MECHATROLINK-II I/O monitor (IO_MON) field	10-7
MECHATROLINK-III I/O signal monitor (SVCMD_IO)	
field	10-8

N

nameplate	1-3
location	1-3

O

order of priority of safety functions	6-30
output circuit	4-6
connections	4-6
electrical specifications	4-6

P

parameter recalculation	xxiii
parameters related Active Mode Function	12-6
Position Error Level for Releasing Active Mode	10-4
position monitoring	xxiii, 6-22, 6-31
proof test	xxiii

R

related utility functions	8-17
risk assessment	5-3

S

safe (HWBB) state	xxiii, 6-12, 6-18, 6-30
Safe BaseBlock Function	xxii, 6-12
basic operation	6-12
exceptional operation	6-13
related SERVOPACK functions	6-14
returning method	6-12
settings	6-12

Safe BaseBlock with Delay Function	xxiii, 6-18	SERVOPACK installation	3-2, 3-3
basic operation	6-18	environment	3-2
exceptional operation	6-20	installation standards	3-4
related SERVOPACK functions	6-21	orientation	3-3
returning method	6-20	SLS-D function	xxiii, 6-26
settings	6-20	basic operation	6-26
Safe Position Monitor with Delay Function	xxiii, 6-22	exceptional operation	6-29
basic operation	6-22	related SERVOPACK functions	6-29
exceptional operation	6-24	returning method	6-28
related SERVOPACK functions	6-25	settings	6-28
returning method	6-24	Speed Reference Level for Releasing Active Mode	10-5
settings	6-24	SPM-D function	xxiii, 6-22
safe state	xxiii, 6-12, 6-18, 6-22, 6-26	basic operation	6-22
Safely Limited Speed with Delay Function	xxiii, 6-26	exceptional operation	6-24
basic operation	6-26	related SERVOPACK functions	6-25
exceptional operation	6-29	returning method	6-24
related SERVOPACK functions	6-29	settings	6-24
returning method	6-28	status display	9-3
settings	6-28	deceleration monitoring	9-3
Safety Function A	6-33	safe (HWBB) state	9-3
Safety Function B	6-34	safe state	9-3
Safety Module I/O Signal Monitor	9-5	system configuration diagram	4-2
Safety Module Monitoring Speed	9-8	system reset	xxiii
Safety Module Motor Position	9-8		
Safety Module Motor Speed	9-8	T	
Safety Module Safety Function Status	9-5	Time until Arrival at Safety Speed	9-7
Safety Module System Status	9-6	troubleshooting of alarms	11-3
Safety Option Module Access Mode Setting	8-3	types of parameters	7-2
operating from the digital operator	8-3	U	
operating from the panel operator	8-4	UKCA	xx
Safety Option Module Initializing Parameter Setting	8-12	UL standards	xix
operating from the digital operator	8-12	Un016	9-5
operating from the panel operator	8-13	Un017	9-5
Safety Option Module Setup Alarm Clear	8-14	Un018	9-6
operating from the digital operator	8-15	Un019	9-7
operating from the panel operator	8-16	Un01A	9-7
Safety Request Input Signal A	4-5	Un01B	9-8
Safety Request Input Signal B	4-5	Un01C	9-8
Safety Request Input Signals	6-4	Un01D	9-8
error detection	6-5	Un01E	9-8
relationship with safety function	6-4	Un01F	9-8
safety request input state	6-4		
Safety-related Module Parameter Setting	8-5		
operating from the digital operator	8-6		
operating from the panel operator	8-7		
safety-related module parameters	xxiii, 7-3, 12-2		
Safety-related Servo Parameter Updating	8-8		
operating from the digital operator	8-8		
operating from the panel operator	8-10		
safety-related servo parameters	xxiii, 7-7, 12-4		
SBB function	xxii, 6-12		
basic operation	6-12		
exceptional operation	6-13		
related SERVOPACK functions	6-14		
returning method	6-12		
settings	6-12		
SBB-D function	xxiii, 6-18		
basic operation	6-18		
exceptional operation	6-20		
related SERVOPACK functions	6-21		
returning method	6-20		
settings	6-20		
selecting a safety function	6-3		

Revision History

The revision dates and numbers of the revised manuals are given on the bottom of the back cover.

MANUAL NO. SIEP C720829 06A <0>-1
 WEB revision number
 Revision number
 Published in Japan June 2011
 Date of publication

Date of Publication	Rev. No.	WEB Rev. No.	Section	Revised Content
February 2026	<11>	0	Preface, 12.4.2	Partly revised.
			Back cover	Revision: Address
June 2025	<10>	0	Preface	Partly revised.
November 2024	<9>	0	Preface	Partly revised.
April 2024	<8>	0	Preface, 3.3	Partly revised.
May 2023	<7>	0	Preface, Chapter 1, 3	Partly revised.
			Back cover	Revision: Address
September 2022	<6>	0	5.3.1	Revision: Graphs for Encoder Output Pulses (Pn212) and Encoder Output Resolution (Pn281) Addition: Monitoring speed margin
			6.2.1, 12.1	Revision: Pc00.3
			6.2.5	Addition: Validating Safety Functions
			6.8 (3)	Revision: Information on checking the operation of safety functions
			6.4.1, 6.6.1	Addition: Information on the monitoring speed margin
September 2020	<5>	2	3.2.2, 9.3.2, 9.3.3	Partly revised.
			9.3.2(1), 9.3.3(1)	Addition: When connected to the MP-series controller
January 2020	<5>	1	All chapters	Addition: MECHATROLINK-4 information
			Preface	Revision: ■ Disposal precautions
			Chapter 1	Revision: Illustration of nameplate
			6.4.5(2), 6.5.5, 6.6.5	Revision: Command name
			9.3.2	Revision: Details on monitoring
			12.4.2	Addition: Rotational Servomotor model: SGMMV
			Back cover	Revision: Address
February 2018	<5>	0	All chapters	Partly revised
			Back cover	Revision: Address
July 2017	<4>	3	6.5.1	Revision: Operation timing diagram related to distance for monitoring
			Back cover	Revision: Address
December 2016	<4>	2	Preface	Revision: European Directives EN ISO13849-1: 2008 → EN ISO13849-1: 2015 Safety Standards EN ISO13849-1: 2008/AC: 2009 → EN ISO13849-1: 2015
			10.2.4, 12.3	Revision: Setting range of Pn628
June 2016	<4>	1	10.3, 12.1, 12.2, 12.3	Revision: Information on reserved parameters
			12.4.2	Revision: SGMAV-C1A → SGMAV-C2A SGM7J-C6A → SGM7J-06A SGM7J-C8A → SGM7J-08A
November 2015	<4>	0	Front cover	Revision: Format
			12.4.2	Addition: Device combinations for direct drive servomotors Model: SGMCV-16D, SGMCV-35D
			Back cover	Revision: Address, format
November 2014	<3>	1	6.6.1	Revision: Operation timing diagram
September 2014	<3>	0	All chapters	Addition: Information on the Σ-7 Series

Date of Publication	Rev. No.	WEB Rev. No.	Section	Revised Content
November 2013	<2>	0	All chapters	Addition: Large-Capacity Σ -V Series information
			Preface, 3.3, 3.12	Revision: EN55011/A2 → EN55011
			Back cover	Revision: Address
June 2012	<1>	0	Preface, 2.2, 3.3.3, Chapter 4, 6.3.5, 6.4.5, 6.5.4, 6.5.5, 6.6.4, 6.6.5, 9.1.2(2), 9.3.2, 10.2.5, 10.4.4, 12.3, 12.4.1	Addition: MECHATROLINK-III information
			3.3.1, 3.3.2	Addition: EMC installation conditions for SGD V-□□□□□□B with SGD V-OSA01A Safety Module
			4.1	Revision: Illustration of CD
			9.2.6, 9.2.8	Addition: Descriptions related to speeds monitored by the Safety Module
			10.2.5(2)	Revision: External device monitor signal output setting → I/O signal monitor
			10.4.3(1)	Revision: Descriptions related to speed control
			10.4.3(2)	Revision: Descriptions related to position control
			10.6.2	Deletion: Servolock information
			Back cover	Revision: Address
June 2011	<0>	1	Front cover	Revision: Format
			6.2.3 (2), 12.1	Revision: Setting of Pc01.1
			Back cover	Revision: Address, format Addition: Original instructions
April 2010	–	–	–	First edition

AC Servo Drives

Σ -V Series

$\sqrt{\Sigma}$ -V Series for

Large-Capacity Models

$\sqrt{\Sigma}$ -7 Series

USER'S MANUAL

Safety Module

IRUMA BUSINESS CENTER (SOLUTION CENTER)

480, Kamifujisawa, Iruma, Saitama, 358-8555, Japan
Phone: +81-4-2962-5151 Fax: +81-4-2962-6138
www.yaskawa.co.jp

YASKAWA AMERICA, INC.

2121, Norman Drive South, Waukegan, IL 60085, U.S.A.
Phone: +1-800-YASKAWA (927-5292) or +1-847-887-7000 Fax: +1-847-887-7310
www.yaskawa.com

YASKAWA ELÉTRICO DO BRASIL LTDA.

777, Avenida Piraporinha, Diadema, São Paulo, 09950-000, Brasil
Phone: +55-11-3585-1100 Fax: +55-11-3585-1187
www.yaskawa.com.br

YASKAWA EUROPE GmbH

Philipp-Reis-Str. 6, 65795 Hattersheim am Main, Germany
Phone: +49-6196-569-300
www.yaskawa.eu.com E-mail: support@yaskawa.eu

YASKAWA ELECTRIC KOREA CORPORATION

6F, 112, LS-ro, Dongan-gu, Anyang-si, Gyeonggi-do, Korea
Phone: +82-31-8015-4224 Fax: +82-31-8015-5034
www.yaskawa.co.kr

YASKAWA ASIA PACIFIC PTE. LTD.

30A, Kallang Place, #06-01, 339213, Singapore
Phone: +65-6282-3003 Fax: +65-6289-3003
www.yaskawa.com.sg

YASKAWA ELECTRIC (THAILAND) CO., LTD.

59, 1F-5F, Flourish Building, Soi Ratchadapisek 18, Ratchadapisek Road, Huaykwang, Bangkok, 10310, Thailand
Phone: +66-2-017-0099 Fax: +66-2-017-0799
www.yaskawa.co.th

YASKAWA ELECTRIC (CHINA) CO., LTD.

22F, Link Square 1, No.222, Hubin Road, Shanghai, 200021, China
Phone: +86-21-5385-2200 Fax: +86-21-5385-3299
www.yaskawa.com.cn

YASKAWA ELECTRIC (CHINA) CO., LTD. BEIJING OFFICE

Room 1011, Tower W3 Oriental Plaza, No.1, East Chang An Avenue,
Dong Cheng District, Beijing, 100738, China
Phone: +86-10-8518-4086 Fax: +86-10-8518-4082

YASKAWA ELECTRIC TAIWAN CORPORATION

12F, No. 207, Section 3, Beishin Road, Shindian District, New Taipei City 23143, Taiwan
Phone: +886-2-8913-1333 Fax: +886-2-8913-1513 or +886-2-8913-1519
www.yaskawa.com.tw

YASKAWA

YASKAWA ELECTRIC CORPORATION

In the event that the end user of this product is to be the military and said product is to be employed in any weapons systems or the manufacture thereof, the export will fall under the relevant regulations as stipulated in the Foreign Exchange and Foreign Trade Act. Therefore, be sure to follow all procedures and submit all relevant documentation according to any and all rules, regulations and laws that may apply. Specifications are subject to change without notice for ongoing product modifications and improvements.

© 2010 YASKAWA ELECTRIC CORPORATION

MANUAL NO. SIEP C720829 06L <11>-0

Published in Japan February 2026

25-9-21

Original instructions