

$\Sigma$ -7/ $\Sigma$ -X-Series AC Servo Drive

# MECHATROLINK-III Communications Standard Servo Profile Command Manual

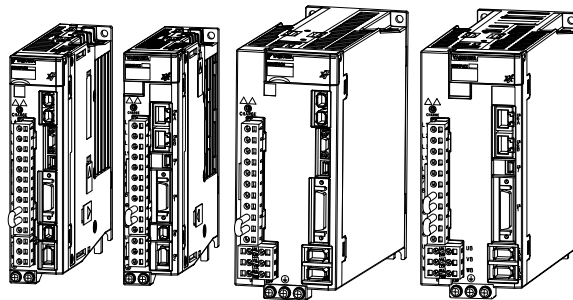

Overview of MECHATROLINK-III  
Communications

1

Command Format

2

Main Commands

3

Subcommands

4

Operation Sequence

5

Function/Command Related Parameters

6

Detecting Alarms/Warnings Related to  
Communications or Commands

7

Common Parameters

8

Virtual Memory Space

9

Appendices

10



# Table of Contents

---

i.	Preface and General Precautions . . . . .	9
i.1	About this Manual . . . . .	10
i.2	Outline of Manual . . . . .	11
i.3	Related Documents . . . . .	12
i.3.1	Related Documents . . . . .	13
i.4	Using This Manual . . . . .	21
i.4.1	Technical Terms Used in This Manual . . . . .	21
i.4.2	Differences in Terms for Rotary Servomotors and Linear Servomotors . . . . .	21
i.4.3	Notation Used in this Manual . . . . .	22
i.4.4	Trademarks . . . . .	23
i.4.5	Visual Aids . . . . .	23
i.5	Safety Precautions . . . . .	24
i.5.1	Safety Information . . . . .	24
i.5.2	Safety Precautions That Must Always Be Observed . . . . .	24
i.6	Warranty . . . . .	36
i.6.1	Details of Warranty . . . . .	36
i.6.2	Limitations of Liability . . . . .	36
i.6.3	Suitability for Use . . . . .	36
i.6.4	Specifications Change . . . . .	37
1.	Overview of MECHATROLINK-III Communications . . . . .	39
1.1	Layers . . . . .	40
1.2	Frame Structure . . . . .	41
1.3	Information on the Extended Address . . . . .	42
1.4	State Transition Diagram . . . . .	43
1.5	Command and Response Timing . . . . .	44
1.5.1	Command Data Execution Timing . . . . .	44
1.5.2	Monitored Data Input Timing . . . . .	44

1.6	List of Commands .....	46
1.6.1	Command Types .....	46
1.6.2	Main Commands .....	46
1.6.3	Subcommands .....	47
1.6.4	Combinations of Main Commands and Subcommands .....	48
<b>2.</b>	<b>Command Format .....</b>	<b>51</b>
2.1	Common Command Format .....	52
2.2	Command Header Section of Main Command Area .....	53
2.2.1	Command Code (CMD/RCMD) .....	53
2.2.2	Watchdog Data (WDT/RWDT) .....	54
2.2.3	Command Control (CMD_CTRL) .....	55
2.2.4	Command Status (CMD_STAT) .....	56
2.3	Command Header Section of Subcommand Area .....	60
2.3.1	Subcommand Codes (SUBCMD/SUBRCMD) .....	60
2.3.2	Subcommand Control (SUB_CTRL) .....	60
2.3.3	Subcommand Status (SUB_STAT) .....	61
2.4	Servo Command Format .....	62
2.5	Command Header Section .....	63
2.5.1	Servo Command Control (SVCMD_CTRL) .....	63
2.5.2	Servo Command Status (SVCMD_STAT) .....	68
2.5.3	Servo Command I/O Signal (SVCMD_IO) .....	70
2.6	Command Data .....	76
2.6.1	Data Order .....	76
2.6.2	Specifying Units .....	76
2.6.3	Specifying Monitor Data .....	77
2.6.4	Position Data .....	77
<b>3.</b>	<b>Main Commands .....</b>	<b>79</b>
3.1	Common Commands .....	81
3.1.1	No Operation Command (NOP: 00h) .....	81
3.1.2	Read ID Command (ID_RD: 03h) .....	82
3.1.3	Setup Device Command (CONFIG: 04h) .....	90
3.1.4	Read Alarm or Warning Command (ALM_RD: 05h) .....	92
3.1.5	Clear Alarm or Warning Command (ALM_CLR: 06h) .....	93
3.1.6	Start Synchronous Communication Command (SYNC_SET: 0Dh) .....	94
3.1.7	Establish Connection Command (CONNECT: 0Eh) .....	95
3.1.8	Disconnection Command (DISCONNECT: 0Fh) .....	96
3.1.9	Read Memory Subcommand (MEM_RD: 1Dh) .....	97

3.1.10	Write Memory Command (MEM_WR: 1Eh)	98
<b>3.2</b>	<b>Servo Commands</b>	<b>101</b>
3.2.1	Set Coordinates Command (POS_SET: 20h)	101
3.2.2	Apply Brake Command (BRK_ON: 21h)	102
3.2.3	Release Brake Command (BRK_OFF: 22h)	103
3.2.4	Turn Sensor ON Command (SENS_ON: 23h)	105
3.2.5	Turn Sensor OFF Command (SENS_OFF: 24h)	105
3.2.6	Servo Status Monitor Command (SMON: 30h)	106
3.2.7	Servo ON Command (SV_ON: 31h)	107
3.2.8	Servo OFF Command (SV_OFF: 32h)	108
3.2.9	Interpolation Command (INTERPOLATE: 34h)	109
3.2.10	Positioning Command (POSING: 35h)	110
3.2.11	Feed Command (FEED: 36h)	112
3.2.12	External Input Feed Command (EX_FEED: 37h)	114
3.2.13	External Input Positioning Command (EX_POSING: 39h)	116
3.2.14	Zero Point Return Command (ZRET: 3Ah)	118
3.2.15	Velocity Control Command (VELCTRL: 3Ch)	121
3.2.16	Torque Control Command (TRQCTRL: 3Dh)	122
3.2.17	Read Servo Parameter Command (SVPRM_RD: 40h)	123
3.2.18	Write Servo Parameter Command (SVPRM_WR: 41h)	124
3.2.19	Motion Command Data Setting Method	125
3.2.20	Restrictions in Using Servo Commands	126
<b>4.</b>	<b>Subcommands</b>	<b>129</b>
4.1	Servo Commands	130
4.1.1	No Operation Subcommand (NOP: 00h)	130
4.1.2	Read Alarm or Warning Subcommand (ALM_RD: 05h)	131
4.1.3	Clear Alarm or Warning Subcommand (ALM_CLR: 06h)	132
4.1.4	Read Memory Subcommand (MEM_RD: 1Dh)	133
4.1.5	Write Memory Subcommand (MEM_WR: 1Eh)	134
4.1.6	Servo Status Monitor Subcommand (SMON: 30h)	135
4.1.7	Read Servo Parameter Subcommand (SVPRM_RD: 40h)	136
4.1.8	Write Servo Parameter Subcommand (SVPRM_WR: 41h)	137
<b>5.</b>	<b>Operation Sequence</b>	<b>139</b>
5.1	Preparing for Operation	140
5.2	Parameter Management and Operation Sequence	141
5.2.1	Operation Sequence for Managing Parameters Using a Controller	141
5.2.2	Operation Sequence for Managing Parameters Using a SERVOPACK	141
5.3	Setting the Zero Point before Starting Operation	143

5.3.1	When Using an Incremental Encoder . . . . .	143
5.3.2	When Using an Absolute Encoder . . . . .	143
5.4	Operation Sequence when Turning the Servo ON . . . . .	144
5.5	Operation Sequence when OT (Overtravel Limit Switch) Signal Is Input. . . . .	145
5.5.1	Operating Sequence When the Overtravel Alarm Is Used . . . . .	145
5.6	Operation Sequence at Emergency Stop (Main Circuit OFF). . . . .	147
5.7	Operation Sequence When a Safety Signal Is Input . . . . .	148
5.7.1	When an HWBB Signal Is Input . . . . .	148
5.7.2	Recovery from Stop Status . . . . .	149
5.8	Operation Sequence at Occurrence of Alarm . . . . .	150
5.9	Notes When the Positioning Completed State (PSET = 1) Is Established While Canceling a Motion Command . . . . .	151
<b>6.</b>	<b>Function/Command Related Parameters . . . . .</b>	<b>153</b>
6.1	Position Control . . . . .	155
6.1.1	INTERPOLATE (Interpolating) . . . . .	155
6.1.2	Positioning Command (POSING, FEED, EX_FEED, EX_POSING, ZRET) . . . . .	155
6.2	Torque Limiting Function . . . . .	158
6.2.1	Internal Torque Limits . . . . .	158
6.2.2	External Torque Limit Using P_CL/N_CL Bits of SVCMD_IO Field . . . . .	158
6.2.3	Torque Limit by Position/Speed Control Command. . . . .	158
6.2.4	Torque Limit When Torque Limiting Functions Are Combined . . . . .	159
6.3	Torque Feedforward Function. . . . .	160
6.3.1	Relationship between the Host Controller and SERVOPACK . . . . .	160
6.3.2	Setting Parameters . . . . .	161
6.4	Speed Feedforward Function . . . . .	162
6.4.1	Relationship between the Host Controller and SERVOPACK . . . . .	162
6.4.2	Setting Parameters . . . . .	162
6.5	Software Limit Function. . . . .	163
6.5.1	Conditions for Enabling the Software Limit Function. . . . .	163
6.5.2	Parameters Related to Software Limit Functions . . . . .	163
6.5.3	Software Limit Monitoring . . . . .	164
6.6	Latch Function . . . . .	165
6.6.1	Continuous Latch by SVCMD_CTRL.LT_REQ2 . . . . .	166
6.6.2	Setting the Latching Allowable Area. . . . .	168
6.7	Acceleration/Deceleration Parameter High-speed Switching Function . . . . .	170
6.7.1	Specifying a Bank . . . . .	170

6.7.2	Parameter Bank Setting	170
6.7.3	Parameters that can Be Registered as Bank Members	170
6.7.4	Setting Procedure	171
6.7.5	Application Notes	172
6.8	Triggers at Preset Positions	174
6.8.1	Setting Command Data	174
6.8.2	Setting Table Parameters List	175
7.	Detecting Alarms/Warnings Related to Communications or Commands	179
7.1	Communication Related Alarms	180
7.1.1	Communication Errors (CMD_STAT.COMM_ALM)	180
7.1.2	Device-Specific Errors (CMD_STAT.D_ALM)	181
7.2	Warnings Related to Communication and Commands	183
7.2.1	Communication Errors (CMD_STAT.COMM_ALM)	183
7.2.2	Command Errors (CMD_STAT.CMD_ALM)	184
7.3	Monitoring Communication Data on Occurrence of an Alarm or Warning	185
7.3.1	$\Sigma$ -X SERVOPACKs	185
7.3.2	$\Sigma$ -7 SERVOPACKs	185
8.	Common Parameters	187
8.1	Overview	188
8.2	List of Common Parameters	189
8.3	Differences between the Common Parameters	200
8.4	Common Parameters and Corresponding Device Parameters	202
9.	Virtual Memory Space	205
9.1	Virtual Memory Space	206
9.1.1	$\Sigma$ -7S/ $\Sigma$ -XS SERVOPACKs	206
9.1.2	$\Sigma$ -7W/ $\Sigma$ -XW SERVOPACKs	207
9.1.3	$\Sigma$ -XT SERVOPACKs	207
9.2	Information Allocated to Virtual Memory	209
9.2.1	ID Information Area	209
9.2.2	Common Parameter Area	210
9.2.3	Adjustment Operation Area	211
10.	Appendices	213

---

10.1	Differences Between MECHATROLINK Commands for $\Sigma$ -7 SERVOPACKs and $\Sigma$ -X SERVOPACKs .....	214
------	---	-----

Revision History .....	215
------------------------	-----



# Preface and General Precautions

---

<b>i.1</b>	<b>About this Manual .....</b>	<b>10</b>
<b>i.2</b>	<b>Outline of Manual .....</b>	<b>11</b>
<b>i.3</b>	<b>Related Documents .....</b>	<b>12</b>
<b>i.3.1</b>	<b>Related Documents .....</b>	<b>13</b>
<b>i.4</b>	<b>Using This Manual.....</b>	<b>21</b>
<b>i.4.1</b>	<b>Technical Terms Used in This Manual .....</b>	<b>21</b>
<b>i.4.2</b>	<b>Differences in Terms for Rotary Servomotors and Linear Servomotors .....</b>	<b>21</b>
<b>i.4.3</b>	<b>Notation Used in this Manual.....</b>	<b>22</b>
<b>i.4.4</b>	<b>Trademarks .....</b>	<b>23</b>
<b>i.4.5</b>	<b>Visual Aids .....</b>	<b>23</b>
<b>i.5</b>	<b>Safety Precautions .....</b>	<b>24</b>
<b>i.5.1</b>	<b>Safety Information.....</b>	<b>24</b>
<b>i.5.2</b>	<b>Safety Precautions That Must Always Be Observed.....</b>	<b>24</b>
<b>i.6</b>	<b>Warranty .....</b>	<b>36</b>
<b>i.6.1</b>	<b>Details of Warranty.....</b>	<b>36</b>
<b>i.6.2</b>	<b>Limitations of Liability .....</b>	<b>36</b>
<b>i.6.3</b>	<b>Suitability for Use.....</b>	<b>36</b>
<b>i.6.4</b>	<b>Specifications Change .....</b>	<b>37</b>

## i.1 About this Manual

This manual describes the specifications of standard servo profile commands used in MECHATROLINK-III communications for the following MECHATROLINK-III communications reference input type SERVOPACKs, the basic operations using these commands, and the parameters for these commands.

Series	Model	SERVOPACK Model
Σ-7-Series	Σ-7S	SGD7S-□□□□20
	Σ-7W	SGD7W-□□□□20
Σ-X-Series	Σ-XS	SGDXS-□□□□40
	Σ-XW	SGDXW-□□□□40
	Σ-XT	SGDXT-□□□□40

Read and understand this manual to ensure correct usage of the Σ-7/Σ-X-series AC servo drives.

Keep this manual in a safe place so that it can be referred to whenever necessary.

### Targeted Readers

- Users who incorporate the MECHATROLINK-III standard servo profile commands in controllers
- Users who design applications for host controllers that use MECHATROLINK-III standard servo profile commands directly



#### Important

- This manual does not apply to users who use MP-series motion controllers for controlling Σ-7/Σ-X-series SERVOPACKs.
- Be sure that you fully understand each command and use the commands in the order appropriate for your application. Incorrect usage of the commands can result not only unexpected motions, but in a serious accident. Special care and verification must be taken for usage of the commands in order to avoid accidents. Be sure to also establish safety measures for the system.

## i.2 Outline of Manual

The contents of the chapters of this manual are described in the following table.

Refer to these chapters as required.

Chapter	Chapter Title	Contents
1	MECHATROLINK-III Communication Settings	Provides detailed information on MECHATROLINK-III communications.
2	Command Format	Describes the common specifications for all commands and the command format.
3	Main Commands	Provides detailed information on the main commands.
4	Subcommands	Provides detailed information on the subcommands.
5	Operation Sequence	Describes basic operation sequences using MECHATROLINK-III communications.
6	Function/Command Related Parameters	Describes the parameter settings required for executing commands and functions.
7	Detecting Alarms/Warnings Related to Communications or Commands	Describes the alarms and warnings that may occur in MECHATROLINK-III communications.
8	Common Parameters	Provides detailed information on the common parameters.
9	Virtual Memory Space	Provides detailed information on the virtual memory space.
10	Appendices	Describes the differences between the MECHATROLINK standard servo profile commands for $\Sigma$ -7 SERVOPACKs and $\Sigma$ -X SERVOPACKs.

# i.3 Related Documents

The relationships between the documents that are related to the servo drives are shown in the following figure. The numbers in the figure correspond to the numbers in the table on the following pages. Refer to these documents as required.

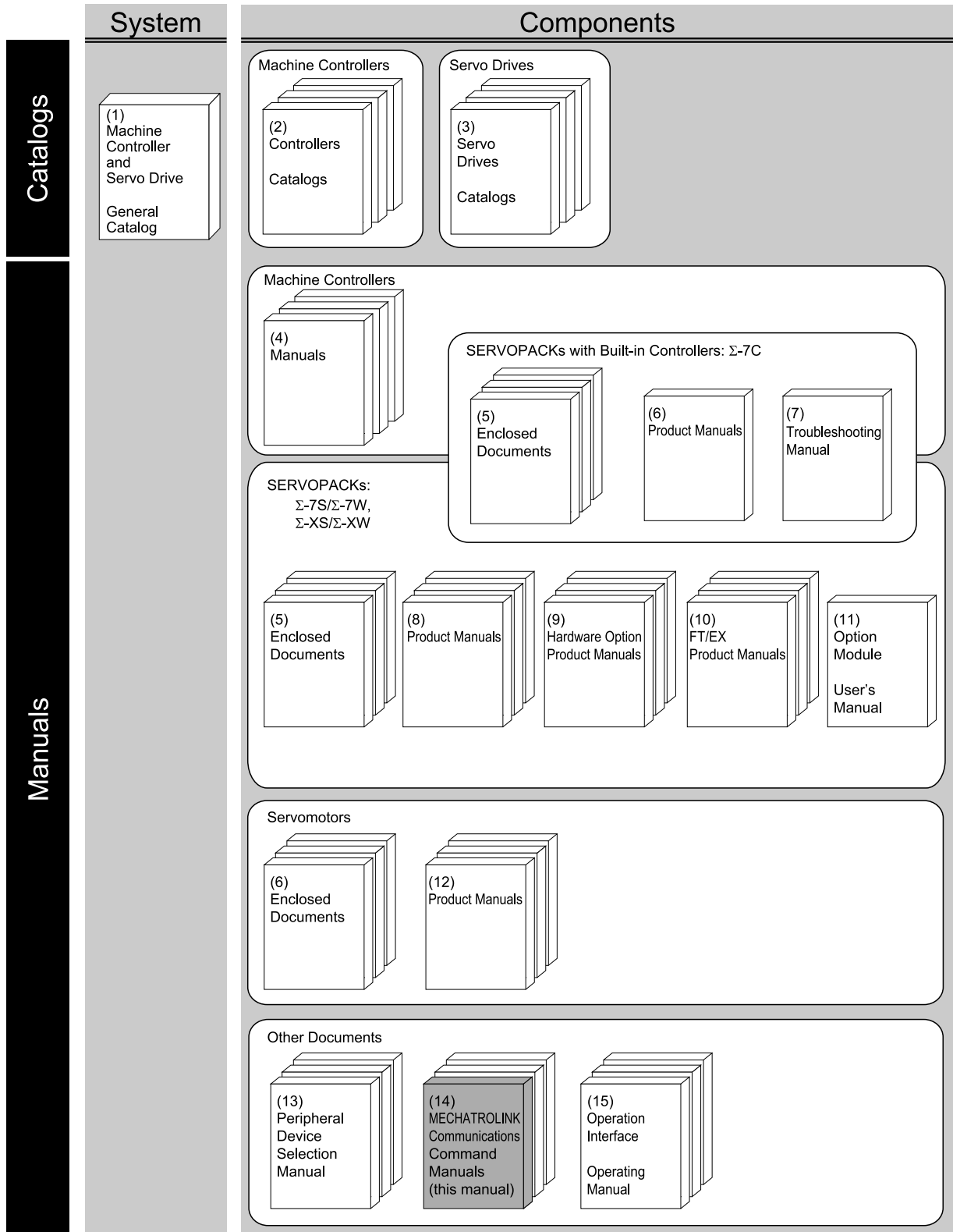

## i.3.1 Related Documents

### (1) Machine Controllers and Servo Drives General Catalog

Document Name	Document No.	Description
Machine Controller and AC Servo Drive Solutions Catalog	KAEP S800001 22	Describes the features and application examples for combinations of MP3000-series machine controllers and $\Sigma$ -7-series AC servo drives.

### (2) Machine Controllers Catalogs

You can check for products related to YASKAWA controllers. Refer to these documents as required.

### (3) Servo Drives Catalogs

Document Name	Document No.	Description
AC Servo Drives $\Sigma$ -X-Series	KAEP C710812 03	Provides detailed information on $\Sigma$ -X-Series AC servo drives, including features and specifications.
AC Servo Drives $\Sigma$ -7-Series	KAEP S800001 23	Provides detailed information on $\Sigma$ -7-Series AC servo drives, including features and specifications.

### (4) Machine Controllers Manuals

The machine controller to use depends on the SERVOPACK that is used. Refer to the manual for the machine controller as required.

### (5) Enclosed Documents

#### (a) SERVOPACK

Document Name	Document No.	Description
$\Sigma$ -X-Series AC Servo Drive $\Sigma$ -XS/ $\Sigma$ -XW SERVOPACK Safety Precautions	TOMP C710812 00	Provides detailed information for the safe usage of $\Sigma$ -X-series SERVOPACKs.
$\Sigma$ -X-Series AC Servo Drive $\Sigma$ -XT SERVOPACK Safety Precautions	TOMP C710812 16	
$\Sigma$ -7-Series AC Servo Drive $\Sigma$ -7S, $\Sigma$ -7W, and $\Sigma$ -7C SERVOPACK Safety Precautions	TOMP C710828 00	Provides detailed information for the safe usage of $\Sigma$ -7-series SERVOPACKs.

#### (b) Servomotors

Document Name	Document No.	Description
AC Servo Drives Rotary Servomotor Safety Precautions	TOBP C230260 00	Provides detailed information for the safe usage of rotary servomotors and direct drive servomotors.
AC Servomotor Linear Servomotor Safety Precautions	TOBP C230842 00	Provides detailed information for the safe usage of linear servomotors.

**(c) Option Modules**

Document Name	Document No.	Description
$\Sigma$ -V-Series/ $\Sigma$ -V-Series for Large-Capacity Models/ $\Sigma$ -7-Series Safety Precautions Option Module	TOBP C720829 00	Provides detailed information for the safe usage of option modules.
$\Sigma$ -V-Series/ $\Sigma$ -V-Series for Large-Capacity Models/ $\Sigma$ -7-Series Installation Guide Command Option Module	TOBP C720829 01	Provides detailed procedures for installing a command option module in a SERVOPACK.
$\Sigma$ -V-Series/ $\Sigma$ -V-Series for Large-Capacity Models/ $\Sigma$ -7-Series/ $\Sigma$ -X-Series Installation Guide Fully-closed Module	TOBP C720829 03	Provides detailed procedures for installing the fully-closed module in a SERVOPACK.
$\Sigma$ -V-Series/ $\Sigma$ -V-Series for Large-Capacity Models/ $\Sigma$ -7-Series Installation Guide Safety Module	TOBP C720829 06	Provides detailed procedures for installing the safety module in a SERVOPACK.
$\Sigma$ -V-Series/ $\Sigma$ -V-Series for Large-Capacity Models/ $\Sigma$ -7-Series Installation Guide INDEXER Module	TOBP C720829 02	Provides detailed procedures for installing the INDEXER module in a SERVOPACK.
$\Sigma$ -V-Series/ $\Sigma$ -V-Series for Large-Capacity Models/ $\Sigma$ -7-Series Installation Guide DeviceNet Module	TOBP C720829 07	Provides detailed procedures for installing the DeviceNet module in a SERVOPACK.

**(d) Peripheral Device**

Document Name	Document No.	Description
$\Sigma$ -X-Series AC Servo Drive $\Sigma$ -LINK II Sensor Hub INSTRUCTIONS	TOMP C710812 06	Provides detailed information for the safe usage of the $\Sigma$ -LINK II sensor hub, as well as specifications, installation, and connection information.
$\Sigma$ -X-Series AC Servo Drive $\Sigma$ -LINK II Booster Unit Instructions	TOMP C710812 08	Provides detailed information for the safe usage of the $\Sigma$ -LINK II booster unit, as well as specifications, installation, and connection information.

**(6)  $\Sigma$ -7-Series  $\Sigma$ -7C SERVOPACK Product Manual**

Document Name	Document No.	Description
$\Sigma$ -7-Series AC Servo Drive $\Sigma$ -7C SERVOPACK Product Manual	SIEP S800002 04	Provides detailed information on selecting $\Sigma$ -7-series $\Sigma$ -7C SERVOPACKs; installing, connecting, setting, testing in trial operation, and tuning servo drives; writing, monitoring, and maintaining programs; and other information.

**(7)  $\Sigma$ -7-Series  $\Sigma$ -7C SERVOPACK Troubleshooting Manual**

Document Name	Document No.	Description
$\Sigma$ -7-Series AC Servo Drive $\Sigma$ -7C SERVOPACK Troubleshooting Manual	SIEP S800002 07	Provides detailed troubleshooting information for $\Sigma$ -7-series $\Sigma$ -7C SERVOPACKs.

**(8)  $\Sigma$ -7/ $\Sigma$ -X-Series SERVOPACK Product Manuals**

Document Name	Document No.	Description
$\Sigma$ -X-Series AC Servo Drive $\Sigma$ -XS SERVOPACK with MECHATROLINK-4/III Communications References Product Manual	SIEP C710812 01	Provide detailed information on selecting $\Sigma$ -X-series $\Sigma$ -XS or $\Sigma$ -XW SERVOPACKs; installing, connecting, setting, testing in trial operation, tuning, monitoring, and maintaining servo drives; and other information.
$\Sigma$ -X-Series AC Servo Drive $\Sigma$ -XS SERVOPACK with EtherCAT Communications References Product Manual	SIEP C710812 02	
$\Sigma$ -X-Series AC Servo Drive $\Sigma$ -XS SERVOPACK with Analog Voltage/Pulse Train References Product Manual	SIEP C710812 03	
$\Sigma$ -X-Series AC Servo Drive $\Sigma$ -XW SERVOPACK with MECHATROLINK-4/III Communications References Product Manual	SIEP C710812 04	
$\Sigma$ -X-Series AC Servo Drive $\Sigma$ -XW SERVOPACK with EtherCAT Communications References Product Manual	SIEP C710812 05	
$\Sigma$ -X-Series AC Servo Drive $\Sigma$ -XT SERVOPACK with MECHATROLINK-4/III Communications References Product Manual	SIEP C710812 16	
$\Sigma$ -X-Series AC Servo Drive $\Sigma$ -XT SERVOPACK with EtherCAT Communications References Product Manual	SIEP C710812 17	

Continued on next page.

Document Name	Document No.	Description
$\Sigma$ -7-Series AC Servo Drive $\Sigma$ -7S SERVOPACK with MECHATROLINK-4 Communications References Product Manual	SIEP S800002 31	Provide detailed information on selecting $\Sigma$ -7-series $\Sigma$ -7S and $\Sigma$ -7W SERVOPACKs; installing, connecting, setting, testing in trial operation, tuning, monitoring, and maintaining server drives; and other information.
$\Sigma$ -7-Series AC Servo Drive $\Sigma$ -7S SERVOPACK with MECHATROLINK-III Communica- tions References Product Manual	SIEP S800001 28	
$\Sigma$ -7-Series AC Servo Drive $\Sigma$ -7S SERVOPACK with MECHATROLINK-II Communications References Product Manual	SIEP S800001 27	
$\Sigma$ -7-Series AC Servo Drive $\Sigma$ -7S SERVOPACK with Analog Voltage/Pulse Train References Product Manual	SIEP S800001 26	
$\Sigma$ -7-Series AC Servo Drive $\Sigma$ -7S SERVOPACK Command Option Attachable Type with INDEXER Module Product Manual	SIEP S800001 64	
$\Sigma$ -7-Series AC Servo Drive $\Sigma$ -7S SERVOPACK Command Option Attachable Type with DeviceNet Module Product Manual	SIEP S800001 70	
$\Sigma$ -7-Series AC Servo Drive $\Sigma$ -7W SERVOPACK with MECHATROLINK-III Communica- tions References Product Manual	SIEP S800001 29	

## (9) $\Sigma$ -7/ $\Sigma$ -X-Series SERVOPACKs with Hardware Option Specifications Product Manuals

Document Name	Document No.	Description
$\Sigma$ -X-Series AC Servo Drive $\Sigma$ -XW/ $\Sigma$ -XT SERVOPACK Hardware Option Specifications HWBB Function Product Manual	SIEP C710812 13	Provide detailed information on hardware options for $\Sigma$ -X-series SERVOPACKs.
$\Sigma$ -X-Series AC Servo Drive $\Sigma$ -XS/ $\Sigma$ -XW/ $\Sigma$ -XT SERVOPACK Hardware Option Specifications Dynamic Brake Product Manual	SIEP C710812 14	
$\Sigma$ -7-Series AC Servo Drive $\Sigma$ -7S/ $\Sigma$ -7W SERVOPACK Hardware Option Specifications Dynamic Brake Product Manual	SIEP S800001 73	Provide detailed information on hardware options for $\Sigma$ -7-series SERVOPACKS.
$\Sigma$ -7-Series AC Servo Drive $\Sigma$ -7W/ $\Sigma$ -7C SERVOPACK Hardware Option Specifications HWBB Function Product Manual	SIEP S800001 72	

## (10) $\Sigma$ -7/ $\Sigma$ -X-Series SERVOPACK FT/EX Specifications Product Manuals

Provide detailed information on the FT/EX option for  $\Sigma$ -7/ $\Sigma$ -X-series SERVOPACKs.

Document Name	Document No.
$\Sigma$ -X-Series AC Servo Drive $\Sigma$ -XS/ $\Sigma$ -XW SERVOPACK MECHATROLINK-4/III Communications References FT Specification for Gantry Applications Product Manual	SIEP C710812 19
$\Sigma$ -X-Series AC Servo Drive $\Sigma$ -XS/ $\Sigma$ -XW SERVOPACK with EtherCAT Communications References FT Specification for Gantry Applications Product Manual	SIEP C710812 20
$\Sigma$ -7-Series AC Servo Drive $\Sigma$ -7S SERVOPACK with FT/EX Specification for Indexing Application Product Manual	SIEP S800001 84
$\Sigma$ -7-Series AC Servo Drive $\Sigma$ -7S SERVOPACK with FT/EX Specification for Tracking Application Product Manual	SIEP S800001 89

Continued on next page.

Document Name	Document No.
$\Sigma$ -7-Series AC Servo Drive $\Sigma$ -7S SERVOPACK with FT/EX Specification for Application with Special Motor, SGM7D Motor Product Manual	SIEP S800001 91
$\Sigma$ -7-Series AC Servo Drive $\Sigma$ -7S SERVOPACK with FT/EX Specification for Press and Injection Molding Application Product Manual	SIEP S800001 94
$\Sigma$ -7-Series AC Servo Drive $\Sigma$ -7S SERVOPACK with FT/EX Specification for Transfer and Alignment Application Product Manual	SIEP S800001 95
$\Sigma$ -7-Series AC Servo Drive $\Sigma$ -7S SERVOPACK with FT/EX Specification for Transfer and Alignment Application Torque/Force Assistance Product Manual	SIEP S800002 09
$\Sigma$ -7-Series AC Servo Drive $\Sigma$ -7S SERVOPACK with FT/EX Specification for Cutting Application Feed Shaft Motor Product Manual	SIEP S800002 10
$\Sigma$ -7-Series AC Servo Drive $\Sigma$ -7S SERVOPACK with FT/EX Specification for Transfer and Alignment Application for Three-Point Latching for Conveyance Application Product Manual	SIEP S800002 17
$\Sigma$ -7-Series AC Servo Drive $\Sigma$ -7S SERVOPACK with FT/EX Specification for Transfer and Alignment Application for Semi-/Fully-Closed Loop Control Online Switching for Conveyance Application Product Manual	SIEP S800002 27
$\Sigma$ -7-Series AC Servo Drive $\Sigma$ -7W SERVOPACK with FT/EX Specification for Gantry Applications Product Manual	SIEP S800002 29

**(11) Option Module User's Manual**

Document Name	Document No.	Description
$\Sigma$ -V-Series/ $\Sigma$ -V-Series for Large-Capacity Models/ $\Sigma$ -7-Series User's Manual Safety Module	SIEP C720829 06	Provides detailed information required for the design and maintenance of a safety module.

**(12)  $\Sigma$ -7/ $\Sigma$ -X-Series Servomotor Product Manuals**

Document Name	Document No.	Description
$\Sigma$ -X-Series AC Servo Drive Rotary Servomotors Product Manual	SIEP C230210 00	Provide detailed information on selecting, installing, and connecting the $\Sigma$ -X-series servomotors.
$\Sigma$ -7-Series AC Servo Drive Rotary Servomotors Product Manual	SIEP S800001 36	Provide detailed information on selecting, installing, and connecting the $\Sigma$ -7-series servomotors.
$\Sigma$ -7-Series AC Servo Drive Linear Servomotors Product Manual	SIEP S800001 37	
$\Sigma$ -7-Series AC Servo Drive Direct Drive Servomotors Product Manual	SIEP S800001 38	

**(13)  $\Sigma$ -7/ $\Sigma$ -X-Series Peripheral Device Selection Manuals**

Document Name	Document No.	Description
$\Sigma$ -X-Series AC Servo Drive Peripheral Device Selection Manual	SIEP C710812 12	Provides detailed information required to select cables, peripheral devices, and options for $\Sigma$ -X-series servo systems. <ul style="list-style-type: none"> <li>• Cables: Model numbers, external dimensions, wire materials, connector model numbers, and wiring specifications</li> <li>• Peripheral devices: Model numbers, specifications, dimensional drawings, and selection (calculation) methods</li> </ul>
$\Sigma$ -7-Series AC Servo Drive Peripheral Device Selection Manual	SIEP S800001 32	Provides detailed information required to select cables, peripheral devices, and options for $\Sigma$ -7-series servo systems. <ul style="list-style-type: none"> <li>• Cables: Model numbers, external dimensions, wire materials, connector model numbers, and wiring specifications</li> <li>• Peripheral devices: Model numbers, specifications, dimensional drawings, and selection (calculation) methods</li> </ul>

**(14)  $\Sigma$ -7/ $\Sigma$ -X-Series MECHATROLINK Communications Command Manuals**

Document Name	Document No.	Description
$\Sigma$ -7/ $\Sigma$ -X-Series AC Servo Drive MECHATROLINK-4 Standard Servo Profile Command Manual	SIEP S800002 32	Provides detailed information on the MECHATROLINK-4 communications standard servo profile commands that are used for a $\Sigma$ -7/ $\Sigma$ -X-series servo system.
$\Sigma$ -7/ $\Sigma$ -X-Series AC Servo Drive MECHATROLINK-III Standard Servo Profile Command Manual	SIEP S800001 31	Provides detailed information on the MECHATROLINK-III communications standard servo profile commands that are used for a $\Sigma$ -7/ $\Sigma$ -X-series servo system.
$\Sigma$ -7-Series AC Servo Drive MECHATROLINK-III Communications Command Manual	SIEP S800001 30	Provides detailed information on the MECHATROLINK-II communications commands that are used for a $\Sigma$ -7-series servo system.

**(15) Operation Interface Operating Manuals**

Document Name	Document No.	Description
System Integrated Engineering Tool MPE720 Ver.7 User's Manual	SIEP C880761 03	Describes in detail how to operate MPE720 version 7.
$\Sigma$ -7/ $\Sigma$ -X-Series AC Servo Drives Digital Operator Operating Manual	SIEP S800001 33	Describes the operating procedures for a digital operator for a $\Sigma$ -7/ $\Sigma$ -X-series servo system.
AC Servo Drive Engineering Tool MPE720 Version 7 SigmaWin+ Operation Manual	SIET S800001 34	Provides detailed operating procedures for the SigmaWin+ Engineering Tool for a $\Sigma$ -7/ $\Sigma$ -X-series servo system.

**(16) Additional Documents: Issued by the MECHATROLINK Members Association**

Document Name	Document No.
MECHATROLINK-III Protocol Specifications	MMA TDEP 020A
MECHATROLINK-III Command Specifications for Standard Servo Profile	MMA TDEP 021A

## i.4 Using This Manual

### i.4.1 Technical Terms Used in This Manual

The following terms are used in this manual.

Term	Meaning
Transmission Cycle	The transmission cycle is the cycle in the MAC layer (Media Access Control layer). It is the communications cycle for physically sending data to the transmission path. The transmission cycle is unaffected by the services provided by the application layer.
Communications Cycle	The communications cycle is the cycle for application layer. The communications cycle is set to an integral multiple of the transmission cycle.
Synchronous Commands (Classification S)	For commands of this type, commands are sent and response are received every communications cycle. The WDT (Watchdog Timer) in the frames are refreshed and checked every communications cycle. Synchronous commands can be used only during synchronous communications (communications phase 3).
Asynchronous Commands (Classification A)	For commands of this type, commands are sent and response are received asynchronously to the communications cycle. Subsequent commands can be sent after confirming the completion of processing of the SDevice station that received the command. The WDT (Watchdog Timer) in the frames are not checked.
Common Command	Commands that are common for MECHATROLINK-III communications, independent of profiles
Servo Commands	Commands that are defined in the MECHATROLINK-III communications standard servo profile commands and specific to SERVOPACKs
Motion Commands	Among servo commands, the following commands are called motion commands. INTERPOLATE, POSING, FEED, EX_FEED, EX_POSING, ZRET, VELCTRL, and TRQCTRL
Position/Speed Control Commands	Among motion commands, the following commands are called position/speed control commands. INTERPOLATE, POSING, FEED, EX_FEED, EX_POSING, ZRET, and VELCTRL
Absolute Encoders	A generic term used for an absolute encoder with a battery and a batteryless absolute encoder. If the explanation is difficult to understand, "batteryless absolute encoder" may also be used for clarity.
MDevice	An abbreviation for a Main Device.
SDevice	An abbreviation for a Subordinate Device.

### i.4.2 Differences in Terms for Rotary Servomotors and Linear Servomotors

There are differences in the terms that are used for rotary servomotors and linear servomotors. This manual primarily describes rotary servomotors. If you are using a linear servomotor, you need to interpret the terms as given in the following table.

Rotary Servomotor	Linear Servomotor
torque	force
moment of inertia	mass
rotation	movement
forward rotation and reverse rotation	forward movement and reverse movement
CW + CCW pulse trains	forward and reverse pulse trains
rotary encoder	linear encoder
absolute rotary encoder	absolute linear encoder
incremental rotary encoder	incremental linear encoder

Continued on next page.

Rotary Servomotor	Linear Servomotor
unit: min <sup>-1</sup>	unit: mm/s
unit: N·m	unit: N

### i.4.3 Notation Used in this Manual

#### (1) Notation for Parameters

The notation depends on whether the parameter requires a numeric setting (parameter for numeric setting) or requires the selection of a function (parameter for selecting functions).

##### (a) Parameters for Numeric Settings

Parameter	Name	Data Size (Byte)	Setting Range	Setting Unit	Default Setting
Pn10A	Feedforward Filter Time Constant	2	0 to 64000	0.01 ms	0

(1) (2) (3) (4) (5)

No.	Description
(1)	Parameter number
(2)	This is the parameter data size in bytes.
(3)	This is the setting range for the parameter.
(4)	This is the setting unit (setting increment) that you can set for the parameter.
(5)	This is the parameter setting before shipment.

##### (b) Parameters for Selecting Functions

Parameter	Meaning	Data Size (Byte)
Pn884	n.□□□0 [Default setting] n.□□□1	2

(1) (2) (3) (4)

No.	Description																												
(1)	Parameter number																												
(2)	<p>The notation "n.□□□□" indicates a parameter for selecting functions. The digit shown as "X" is the content being explained in this parameter.</p> <p>Notation Example</p> <table border="1"> <thead> <tr> <th colspan="2">Notation Example for Pn002</th> <th colspan="2">Numeric Value Notation</th> </tr> <tr> <th colspan="2">Digit Notation</th> <th colspan="2">Numeric Value Notation</th> </tr> <tr> <th>Notation</th> <th>Meaning</th> <th>Notation</th> <th>Meaning</th> </tr> </thead> <tbody> <tr> <td>Pn002 = n.□□□X</td> <td>Indicates the first digit from the right in Pn002.</td> <td>Pn002 = n.□□□1</td> <td>Indicates that the first digit from the right in Pn002 is set to 1.</td> </tr> <tr> <td>Pn002 = n.□□X□</td> <td>Indicates the second digit from the right in Pn002.</td> <td>Pn002 = n.□□1□</td> <td>Indicates that the second digit from the right in Pn002 is set to 1.</td> </tr> <tr> <td>Pn002 = n.□X□□</td> <td>Indicates the third digit from the right in Pn002.</td> <td>Pn002 = n.□1□□</td> <td>Indicates that the third digit from the right in Pn002 is set to 1.</td> </tr> <tr> <td>Pn002 = n.X□□□</td> <td>Indicates the fourth digit from the right in Pn002.</td> <td>Pn002 = n.1□□□</td> <td>Indicates that the fourth digit from the right in Pn002 is set to 1.</td> </tr> </tbody> </table>	Notation Example for Pn002		Numeric Value Notation		Digit Notation		Numeric Value Notation		Notation	Meaning	Notation	Meaning	Pn002 = n.□□□X	Indicates the first digit from the right in Pn002.	Pn002 = n.□□□1	Indicates that the first digit from the right in Pn002 is set to 1.	Pn002 = n.□□X□	Indicates the second digit from the right in Pn002.	Pn002 = n.□□1□	Indicates that the second digit from the right in Pn002 is set to 1.	Pn002 = n.□X□□	Indicates the third digit from the right in Pn002.	Pn002 = n.□1□□	Indicates that the third digit from the right in Pn002 is set to 1.	Pn002 = n.X□□□	Indicates the fourth digit from the right in Pn002.	Pn002 = n.1□□□	Indicates that the fourth digit from the right in Pn002 is set to 1.
Notation Example for Pn002		Numeric Value Notation																											
Digit Notation		Numeric Value Notation																											
Notation	Meaning	Notation	Meaning																										
Pn002 = n.□□□X	Indicates the first digit from the right in Pn002.	Pn002 = n.□□□1	Indicates that the first digit from the right in Pn002 is set to 1.																										
Pn002 = n.□□X□	Indicates the second digit from the right in Pn002.	Pn002 = n.□□1□	Indicates that the second digit from the right in Pn002 is set to 1.																										
Pn002 = n.□X□□	Indicates the third digit from the right in Pn002.	Pn002 = n.□1□□	Indicates that the third digit from the right in Pn002 is set to 1.																										
Pn002 = n.X□□□	Indicates the fourth digit from the right in Pn002.	Pn002 = n.1□□□	Indicates that the fourth digit from the right in Pn002 is set to 1.																										

Continued on next page.

Continued from previous page.

No.	Description
(3)	This column explains the selections for the function. In the above example, the first line gives an explanation of when Pn884 = n.□□□0 is set.
(4)	This column shows the parameter data size in bytes.

## i.4.4 Trademarks

- MECHATROLINK is a trademark of the MECHATROLINK Members Association.
- Σ-LINK is a trademark of the MECHATROLINK Members Association.
- Other product names and company names are the trademarks or registered trademarks of their respective companies. "TM" and the ® mark do not appear with product or company names in this manual.

## i.4.5 Visual Aids

The following aids are used to indicate certain types of information for easier reference.



Important

Indicates precautions or restrictions that must be observed.

Also indicates alarm displays and other precautions that will not result in machine damage.



Term

Indicates definitions of difficult terms or terms that have not been previously explained in this manual.

Information

Indicates supplemental information to deepen understanding or useful information.

## i.5 Safety Precautions

### i.5.1 Safety Information

To prevent personal injury and equipment damage in advance, the following signal words are used to indicate safety precautions in this document. The signal words are used to classify the hazards and the degree of damage or injury that may occur if a product is used incorrectly. Information marked as shown below is important for safety. Always read this information and heed the precautions that are provided.



#### **DANGER**

This signal word identifies a hazard that will cause serious injury or death if you do not prevent it.



#### **WARNING**

This signal word identifies a hazard that can cause death or serious injuries if you do not prevent it.



#### **CAUTION**

This signal word identifies a hazard that can cause moderate injuries if you do not prevent it.

#### **NOTICE**

This signal word identifies a property damage message that is not related to personal injury.

### i.5.2 Safety Precautions That Must Always Be Observed

#### (1) General Precautions



#### **DANGER**

**Make sure to observe all information related to safety contained in this manual.**

If you fail to observe these warnings, there is a risk of equipment damage or product failure. There is also a risk of injury, fire, or electric shock that causes death or serious injury.

Yaskawa bears no responsibility to you or your customers for injuries and equipment damage that occur from failing to observe the warnings and precautions listed in this manual.

**Keep this manual in a safe, convenient place so that it can be referred to whenever necessary. Make sure that it is delivered to the final user of the product.**

**Install and remove covers, cables, connectors, and optional devices when the power is turned OFF.**

There is a risk of equipment damage or product failure. There is also a risk of fire or electric shock that causes death or serious injury. Additionally, there is a risk of death or serious injury due to unexpected machine operation.

**WARNING**

**Use a power supply with specifications (number of phases, voltage, frequency, and AC/DC type) that are appropriate for the product. Always check the power supply specifications in this manual.**

If you do not use the product with the correct power supply specifications, there is a risk of thermal damage, fire, or electric shock because of product overheating due to the application of high voltage or leakage current, and these may cause death or serious injury.

**Make sure to connect the ground terminals on the SERVOPACK and servomotor to ground poles in the state shown below.**

- **SERVOPACK with 100-VAC power supply input: 100  $\Omega$  max.**
- **SERVOPACK with 200-VAC power supply input: 100  $\Omega$  max.**
- **SERVOPACK with 400-VAC power supply input: 10  $\Omega$  max.**

There is a risk of product failure. A fire or electric shock may also occur resulting in death or serious injury.

**A SERVOPACK with 400-VAC power supply input can be used only in a power system with grounded neutral. Make sure to connect the SERVOPACK to a power supply with grounded neutral.**

If the SERVOPACK is connected to a power supply without a grounded neutral, there is a risk of electric shock and product failure. A fire or electric shock may also occur resulting in death or serious injury.

**Do not modify or alter the product in any manner that is not described in this manual.**

If you modify or alter the product, there is a risk of fire or electric shock that causes death or serious injury.

Repairs for product damage caused by modifying or altering the product in a manner not described in this manual are outside the scope of the Yaskawa warranty. Yaskawa bears no responsibility for product alterations performed by you or your customers.

**For a 24-VDC power supply, use a power supply device with double insulation or reinforced insulation.**

There is a risk of injury, fire, or electric shock that causes death or serious injury when a short circuit or ground fault occurs due to insulation deterioration in the device.

**Do not damage, pull on, apply excessive force to, place heavy objects on, or pinch cables.**

There is a risk of fire or electric shock due to cable failure or damage that causes death or serious injury.

**The person who designs the system that uses the safety function must have a complete knowledge of the related safety standards and a complete understanding of the instructions in this document.**

If the safety design of the system is insufficient, there is a risk of equipment damage. There is also a risk of death or serious injury due to unexpected machine operation.

**Do not place the product in locations where it is subject to water, corrosive gases, flammable gases, potentially explosive atmospheres, or near flammable materials.**

There is a risk of product failure. A fire or electric shock may also occur resulting in death or serious injury.

**Install external emergency stop circuits that can turn OFF the power and stop operation immediately in case an error occurs.**

There is a risk of equipment damage and death or serious injury due to unexpected machine operation.

**Always use a servomotor and SERVOPACK in one of the specified combinations.**

There is a risk of product failure. There is also a risk of fire that causes death or serious injury. Additionally, there is a risk of death or serious injury due to unexpected machine operation.

**Do not touch a SERVOPACK or servomotor with wet hands.**

There is a risk of product failure if the SERVOPACK and servomotor get wet. A fire or electric shock may also occur resulting in death or serious injury.



## CAUTION

**The SERVOPACK heat sinks, regenerative resistors, external dynamic brake resistors, servomotors, and other components can be very hot while power is ON or soon after the power is turned OFF. Implement safety measures, such as installing covers, so that hands and parts such as cables do not come into contact with hot components.**

There is a risk of burns from touching hot components.

## NOTICE

**Do not attempt to use a SERVOPACK or servomotor that is damaged or that has missing parts.**

There is a risk that the product may not function correctly.

**In environments with unstable power supply, install the necessary protective devices (such as AC reactors) to ensure that the input power is supplied within the specified voltage range.**

There is a risk of product failure.

**Minimize the effects of electromagnetic interference by connecting a device, such as a noise filter.**

There is a risk of equipment or product malfunction.

## (2) Storage Precautions



## WARNING

**Do not place an excessive load on the product. Follow the labels on the shipping box regarding product loading.**

There is a risk of the product falling and causing product damage or failure. There is also a risk of death or serious injury.

**Do not install or store the product in any of the following locations.**

- **Locations that are subject to direct sunlight**
- **Locations that are subject to surrounding air temperatures that exceed product specifications**
- **Locations that are subject to relative humidities that exceed product specifications**
- **Locations that are subject to condensation as the result of extreme changes in temperature**
- **Locations that are subject to corrosive or flammable gases**
- **Locations that are near flammable materials**
- **Locations that are subject to dust, salts, or iron powder**
- **Locations that are subject to water, oil, or chemicals**
- **Locations that are subject to vibration or shock that exceeds product specifications**
- **Locations that are subject to radiation**

If you store or install the product in any of the above locations, there is a risk of product failure. A fire or electric shock may also occur resulting in death or serious injury.

### (3) Transportation Precautions

#### **WARNING**

**Transport the product in a way that is suitable to the mass of the product.**

There is a risk of the product falling and causing product damage or failure. There is also a risk of death or serious injury.

**Do not use the lifting hardware on a SERVOPACK or servomotor to move the entire machine.**

There is a risk of the product falling due to improper use of lifting hardware and causing product and equipment damage or failure. There is also a risk of death or serious injury.

**Do not place an excessive load on the product. Follow the labels on the shipping box regarding product loading.**

There is a risk of the product falling and causing product damage or failure. There is also a risk of death or serious injury.

**Do not overtighten the lifting hardware on the SERVOPACK and servomotor.**

If you use a tool to overtighten the lifting hardware, the product may be damaged. The product may also be damaged and fall causing death or serious injury.

#### **CAUTION**

**When you handle a SERVOPACK or servomotor, be careful of sharp edges, such as the corners.**

There is a risk of injury.

**When you move the SERVOPACK, hold the main body directly and not the front cover or connectors.**

If you move the SERVOPACK by holding the front cover or connectors, those parts may break off and cause product damage, product failure, or injury.

#### **NOTICE**

**A SERVOPACK or servomotor is a precision device. Do not drop it or subject it to impact or excessive force.**

There is a risk of product damage or failure.

**Avoid applying mechanical shock or impact to connectors.**

There is a risk of product damage or failure.

**If disinfectants or insecticides must be used to treat packing materials such as wooden frames, plywood, or pallets, use a method other than fumigation.**

**For example, use heat sterilization (core temperature of 56°C or higher for 30 minutes or longer).**

**Treat the packing materials before the product is packaged instead of using a method that treats the entire packaged product.**

If the electronic products, which include stand-alone products and products installed in machines, are packed with fumigated wooden materials, the electrical components may be greatly damaged by the gases or fumes resulting from the fumigation process. In particular, disinfectants containing halogen, which includes chlorine, fluorine, bromine, or iodine, can contribute to product failure by corroding the insides of capacitors.

## (4) Installation Precautions



### WARNING

**Install the SERVOPACK and the servomotor using mounting that can support their mass. Check the masses of the SERVOPACK and the servomotor in the respective instruction manuals, and install the SERVOPACK and the servomotor by following the chapters related to installation in the respective product manuals.**

In case of improper installation, there is a risk of the SERVOPACK and servomotor falling and causing damage or failure to equipment and the product. There is also a risk of death or serious injury.

**Install SERVOPACKs, servomotors, regenerative resistors, and external dynamic brake resistors on nonflammable materials.**

Installation directly onto or near flammable materials may result in fire that causes death or serious injury.

**Provide the specified clearances between the SERVOPACK and the control panel and other devices. Refer to "Mounting Interval" in the product manual for your SERVOPACK for the specified clearances.**

There is a risk of product failure if the SERVOPACK temperature and the temperature around the SERVOPACK locally exceed the surrounding air temperature range. There is also a risk of fire that causes death or serious injury.

**Install the SERVOPACK in the specified orientation.**

There is a risk of product failure if the SERVOPACK temperature and the temperature around the SERVOPACK locally exceed the surrounding air temperature range. There is also a risk of fire that causes death or serious injury.

**Do not allow any foreign matter to enter the SERVOPACK or servomotor.**

There is a risk of product failure. There is also a risk of fire that causes death or serious injury.

**Do not install or store the product in any of the following locations.**

- **Locations that are subject to direct sunlight**
- **Locations that are subject to surrounding air temperatures that exceed product specifications**
- **Locations that are subject to relative humidities that exceed product specifications**
- **Locations that are subject to condensation as the result of extreme changes in temperature**
- **Locations that are subject to corrosive or flammable gases**
- **Locations that are near flammable materials**
- **Locations that are subject to dust, salts, or iron powder**
- **Locations that are subject to water, oil, or chemicals**
- **Locations that are subject to vibration or shock that exceeds product specifications**
- **Locations that are subject to radiation**

If you store or install the product in any of the above locations, there is a risk of product failure. A fire or electric shock may also occur resulting in death or serious injury.



### CAUTION

**Do not step on or place a heavy object on the product.**

There is a risk of product damage or failure because the product cannot withstand the load.

## NOTICE

**Use the product in an environment that is appropriate for the product specifications.**

There is a risk of product damage or failure if you use the product in an environment that exceeds the product specifications.

**A SERVOPACK or servomotor is a precision device. Do not drop it or subject it to impact or excessive force.**

There is a risk of product damage or failure.

**Always install a SERVOPACK in a control panel.**

**Do not allow any foreign matter to enter a SERVOPACK or a servomotor with a cooling fan and do not cover the outlet from the servomotor's cooling fan.**

There is a risk of product failure.

### (5) Wiring Precautions



## DANGER

**Do not change any wiring while power is being supplied.**

There is a risk of equipment damage or product failure. There is also a risk of fire or electric shock that causes death or serious injury. Additionally, there is a risk of death or serious injury due to unexpected machine operation.

**Wait for at least the amount of time listed below for your SERVOPACK after turning OFF the power supply and then make sure that the CHARGE indicator is not lit before starting wiring or inspection work. Do not touch the main circuit terminals while the CHARGE indicator is lit because high voltage may still remain in the SERVOPACK even after turning OFF the power.**

- $\Sigma$ -X-series SERVOPACK: 20 minutes or longer
- $\Sigma$ -7-series SERVOPACK with 200-VAC power supply input: 6 minutes or longer
- $\Sigma$ -7-series SERVOPACK with 100-VAC power supply input: 9 minutes or longer

There is a risk of electric shock that causes death or serious injury.



## WARNING

**Wiring and inspections must be performed only by qualified engineers.**

If work is performed by a worker who is not a qualified engineer, there is a risk of fire or electric shock that causes death or serious injury.

**Check all wiring and power supplies carefully.**

Incorrect wiring or incorrect voltage application to the output circuits may cause short-circuit failures. If this failure occurs, there is a risk of fire that causes death or serious injury. There is also a risk of equipment and product damage because the holding brake may fail to operate properly.

**WARNING**

**Always use the specified terminals to connect the SERVOPACK and peripheral devices. For the power supply in particular, confirm that the connections are made to the terminals shown below.**

**100-V power supply input SERVOPACK:**

- AC power supply: L1, L2, L1C, L2C terminals on the SERVOPACK

**200-V power supply input SERVOPACK:**

- AC power supply: L1, L2, L3, L1C, L2C terminals on the SERVOPACK
- DC power supply: B1/⊕, ⊖2, L1C, L2C terminals on the SERVOPACK

**400-V power supply input SERVOPACK:**

- AC power supply: L1, L2, L3 terminals on the SERVOPACK
- DC power supply: B1/⊕, ⊖2 terminals on the SERVOPACK
- 24-VDC control power supply: 24-V and 0-V terminals (same whether the main circuit power supply wiring is an AC power supply or a DC power supply)

**Refer to "Terminal Symbols and Terminal Names" in the product manual for your SERVOPACK for details on terminals.**

If you ignore these precautions, there is a risk of equipment failure or product failure due to fire. There is also a risk of fire that causes death or serious injury.

**If you use a SERVOPACK with the dynamic brake hardware option, connect an external dynamic brake resistor that is suitable for the machine and equipment specifications to the specified terminals.**

There is a risk of equipment damage due to unintended machine operation during an emergency stop. There is also a risk of injury or fire that causes death or serious injury.

**Observe the precautions and instructions for wiring and trial operation precisely as described in "Wiring" and "Holding Brake" in the product manual for your SERVOPACK.**

If a mistake is made in wiring or trial operation, there is a risk of product failure due to incorrect wiring or incorrect voltage application in the brake circuit. A fire or electric shock may also occur resulting in death or serious injury. Additionally, there is a risk of death or serious injury due to unexpected machine operation.

**Check the wiring to be sure it has been performed correctly. Connectors and pin layouts may vary depending on the model. Always confirm the pin layout examples in the chapter related to pin layouts in the product manual for your model.**

If the wiring is not performed correctly, there is a risk of product failure. There is also a risk of fire or electric shock that causes death or serious injury. Additionally, there is a risk of death or serious injury due to unexpected machine operation.

**Connect wires to main circuit terminals and motor connection terminals securely with the specified methods and tightening torque. Refer to "SERVOPACK Main Circuit Wires" in the peripheral selection manual for your SERVOPACK for the specified methods and tightening torque.**

Insufficient tightening may cause wires and terminal blocks to generate heat due to poor contact, possibly resulting in product failure. There is also a risk of fire that causes death or serious injury.

**Make sure the cables do not exceed the following lengths:**

- I/O signal cable: 3 m max.
- Servomotor main circuit cable: 50 m max.
- Encoder cable: 50 m max.
- Control power supply cable for 400-V power supply input SERVOPACK (+24 V and 0 V): 10 m max.

If a cable is longer than the specified length, there is a risk of equipment damage due to product malfunction that causes death or serious injury. There is also a risk of electric shock due to a short circuit or ground fault that causes death or serious injury.

 **WARNING**

**Observe the following precautions when wiring the SERVOPACK's main circuit terminals.**

- **Turn ON the power to the SERVOPACK only after all wiring, including the main circuit terminals, has been completed.**
- **If a connector is used for the main circuit terminals, remove the main circuit connector from the SERVOPACK before you wire it.**
- **Insert only one wire per insertion hole in the main circuit terminals.**
- **When you insert a wire, make sure that the conductor wire (e.g., whiskers) does not come into contact with adjacent wires and cause a short-circuit.**

If the SERVOPACK power is turned ON with incorrect wiring, there is a risk of fire due to electric shock or product failure that causes death or serious injury.

**Install molded-case circuit breakers and other safety measures to provide protection against short circuits in external wiring.**

There is a risk of fire or electric shock due to product failure that causes death or serious injury.

**Install a battery at either the host controller or on the encoder cable.**

If you install batteries both at the host controller and on the encoder cable at the same time, you will create a loop circuit between the batteries, and this may result in a fire from product failure or damage that causes death or serious injury.

**When connecting a battery, connect the polarity correctly.**

There is a risk of encoder failure if the battery ruptures and a risk of fire that causes death or serious injury.

 **CAUTION**

**Use shielded twisted-pair cables or shielded multi-core twisted-pair cables for I/O signal cables and encoder cables.**

There is a risk of injury from product malfunction.

**NOTICE**

**Use the cables specified by Yaskawa. If you use any other cables, confirm the rated current and application environment of your model and use the wiring materials specified by Yaskawa or equivalent materials. Refer to the peripheral selection manual for your SERVOPACK for Yaskawa-specified cables and wiring materials.**

**Securely tighten connector screws and lock mechanisms.**

Insufficient tightening may result in connectors falling off during operation.

**Do not bundle power lines (e.g., the main circuit cable) and low-current lines (e.g., the I/O signal cables or encoder cables) together or run them through the same duct. If you do not place power lines and low-current lines in separate ducts, separate them by at least 30 cm.**

There is a risk that the product may not function correctly due to the effects of noise on low-current lines.

## (6) Operation Precautions

 **WARNING**

**Before starting operation with a machine connected, configure the settings of the switches and parameters to match the machine. Always check the settings of the switches and parameters in the product manual for your SERVOPACK.**

If operation is performed without configuring the settings, there is a risk of equipment damage and death or serious injury due to unexpected machine operation.

**Do not significantly change the settings of the parameters.**

There is a risk of equipment damage and death or serious injury due to unexpected machine operation.

**WARNING**

**Install safety equipment (e.g., limit switches or stoppers) in an appropriate manner at the ends of the moving parts of the machine to prevent unexpected accidents.**

If safety equipment is not installed in an appropriate manner, there is a risk of equipment damage and death or serious injury due to unexpected machine operation.

**For trial operation, securely mount the servomotor and disconnect it from the machine.**

There is a risk of equipment damage and death or serious injury due to unexpected machine operation.

**Forced stops for overtravel is disabled when the Jog, Origin Search, or Easy FFT utility function is executed. Ensure that appropriate safety measures are in place around moving parts.**

There is a risk of equipment damage and death or serious injury due to unexpected machine operation.

**When an alarm occurs, the servomotor will coast to a stop or stop with the dynamic brake according to the SERVOPACK option and settings. The coasting distance will change with the moment of inertia of the load and the external dynamic brake resistance. Check the coasting distance during trial operation and implement suitable safety measures on the machine.**

**Refer to the product manual for your SERVOPACK for the specifications of SERVOPACK options.**

There is a risk of equipment damage and death or serious injury due to unexpected machine operation.

**Do not enter the machine's range of motion during operation.**

There is a risk of death or serious injury from entrapment or the machine making contact with your body due to unexpected equipment or system operation.

**Do not touch the moving parts of the servomotor or machine during operation.**

There is a risk of death or serious injury from entrapment or the machine making contact with your body due to unexpected equipment or system operation.

**Perform the correct operation with the servomotor connected to the machine.**

There is a risk of equipment damage or product damage. There is also a risk of fire that causes death or serious injury.

**Design the system to ensure safety even when problems, such as broken signal lines, occur. For example, the SERVOPACK's P-OT (Forward Drive Prohibit Input) and N-OT (Reverse Drive Prohibit Input) signals are set in the default settings to operate on the safe side if a signal line breaks. Do not change the polarity of this type of signal. Refer to "Overtravel Function and Settings" in the product manual for your SERVOPACK for the P-OT and N-OT signals.**

If there is poor contact or a cable break occurs when safety is neglected or the signal polarities are changed, there is a risk of equipment damage because the SERVOPACK will not stop when the P-OT and N-OT signals are input. There is also a risk of death or serious injury due to unexpected machine operation.

**Use the dynamic brake only for emergency stop applications.**

If used for any other applications, there is a risk of rapid deterioration of internal components in the SERVOPACK as well as equipment or product damage. There is also a risk of fire that causes death or serious injury.

**In the following situations, use the SigmaWin+ to back up the settings of the SERVOPACK parameters, and then apply the backed up parameter settings after the SERVOPACK is replaced.**

- Before replacement or shipment when shipping a SERVOPACK to Yaskawa for SERVOPACK or part replacement
- After you complete tuning and trial operation of the machine and facilities

**Refer to the SigmaWin+ Operation Manual for saving parameter settings to a file and applying saved parameter settings.**

If you fail to perform these operations, the SERVOPACK may not operate normally after replacement or after trial operation, and there is a risk of equipment damage. There is also a risk of death or serious injury due to unexpected machine operation.

## NOTICE

**Always turn OFF the servo before you turn OFF the power. If you turn OFF the main circuit power or control power during operation before you turn OFF the servo, the servomotor stopping method will be executed as follows regardless of the stopping method set in the parameter.**

- **If you turn OFF the main circuit power during operation without turning OFF the servo, the servomotor will stop abruptly with the dynamic brake.**
- **If you turn OFF the control power without turning OFF the servo, the stopping method that is used by the servomotor depends on the model of the SERVOPACK. For details, refer to the manual for your SERVOPACK.**
- **If you use a SERVOPACK with the dynamic brake hardware option, the servomotor stopping methods will be different from the stopping methods used without the option or with other hardware options. For details, refer to the manual for your SERVOPACK.**

Depending on the usage conditions of the servomotor, there is a risk of equipment damage.

**When you adjust the gain during system commissioning, use a measuring instrument to monitor the torque waveform and speed waveform and confirm that there is no vibration.**

If a high gain causes vibration, the servomotor will be damaged quickly.

**Do not frequently turn the power ON and OFF. After you have started actual operation, allow at least one hour between turning the power ON and OFF (for reference only). Do not use the product in applications that require the power to be turned ON and OFF frequently.**

Frequently turning the power ON and OFF may rapidly deteriorate internal components in the SERVOPACK or cause the product to fail.

**An alarm or warning may occur if communications are performed with the host controller while the SigmaWin+ or digital operator is operating.**

If an alarm or warning occurs, it may interrupt the current process and stop the system.

## (7) Maintenance and Inspection Precautions



### DANGER

**Do not change any wiring while power is being supplied.**

There is a risk of equipment damage or product failure. There is also a risk of fire or electric shock that causes death or serious injury. Additionally, there is a risk of death or serious injury due to unexpected machine operation.

**Wait for at least the amount of time listed below for your SERVOPACK after turning OFF the power supply and then make sure that the CHARGE indicator is not lit before starting wiring or inspection work. Do not touch the main circuit terminals while the CHARGE indicator is lit because high voltage may still remain in the SERVOPACK even after turning OFF the power.**

- **Σ-X-series SERVOPACK: 20 minutes or longer**
- **Σ-7-series SERVOPACK with 200-VAC power supply input: 6 minutes or longer**
- **Σ-7-series SERVOPACK with 100-VAC power supply input: 9 minutes or longer**

There is a risk of electric shock that causes death or serious injury.

**WARNING**

**Wiring and inspections must be performed only by qualified engineers.**

If work is performed by a worker who is not a qualified engineer, there is a risk of fire or electric shock that causes death or serious injury.

**When shipping a SERVOPACK to Yaskawa for SERVOPACK or part replacement, use the SigmaWin+ to back up the settings of the SERVOPACK parameters. Apply the backed up parameter settings before using the replaced SERVOPACK. Refer to the SigmaWin+ Operation Manual for saving parameter settings to a file and applying saved parameter settings.**

The parameters of any SERVOPACKs that are sent to Yaskawa for part replacement are reset to the factory settings before they are returned to you. If you fail to perform these operations, there is a risk of equipment damage and death or serious injury due to unexpected machine operation.

**NOTICE**

**Discharge all static electricity from your body before you operate any of the buttons or switches inside the front cover of the SERVOPACK.**

There is a risk of equipment damage or product failure.

**(8) Troubleshooting Precautions****DANGER**

**If the safety device (molded-case circuit breaker or fuse) installed in the power line operates, repair or replace the SERVOPACK, check the wiring, and remove the factor that caused the safety device to operate. After you confirm that the factor was removed, supply power to the SERVOPACK.**

There is a risk of equipment damage or product failure. There is also a risk of fire or electric shock that causes death or serious injury. Additionally, there is a risk of death or serious injury due to unexpected machine operation.

**WARNING**

**The product may suddenly start to operate when the power supply is recovered after a momentary power interruption. Design the machine to ensure human safety when operation restarts.**

There is a risk of equipment damage and death or serious injury due to unexpected machine operation.

**When an alarm occurs, remove the cause of the alarm and ensure safety. Then reset the alarm or turn the power OFF and ON again to restart operation.**

There is a risk of equipment damage or product failure. There is also a risk of injury, fire, or electric shock that causes death or serious injury.

**If the Servo ON signal is input to the SERVOPACK and an alarm is reset, the servomotor may suddenly restart operation. Make sure to confirm that the servo is OFF and ensure safety before you reset an alarm.**

There is a risk of equipment damage and death or serious injury due to unexpected machine operation.

**Always insert a magnetic contactor in the line between the main circuit power supply and the main circuit terminals on the SERVOPACK so that the power can be turned OFF at the main circuit power supply.**

There is a risk of fire due to internal component failure in the SERVOPACK that causes death or serious injury.



## WARNING

**If an alarm occurs, turn OFF the main circuit power supply.**

There is a risk of fire and death or serious injury due to a regenerative resistor overheating as the result of regenerative transistor failure.

**Install a ground fault detector against overloads and short-circuiting or install a molded-case circuit breaker combined with a ground fault detector.**

If a ground fault occurs, there is a risk of injury, fire, or electric shock due to SERVOPACK failure that causes death or serious injury.

**The holding brake alone on a servomotor will not ensure safety if there is the possibility that an external force (including gravity) may move the current position and create a hazardous situation when power is interrupted or an error occurs. To ensure safety, make sure to install an external braking mechanism.**

There is a risk of equipment damage and death or serious injury due to unexpected machine operation.

## (9) General Precautions

- Figures provided in this manual are typical examples or conceptual representations. There may be differences between them and actual wiring, circuits, and products.
- The products shown in illustrations in this manual are sometimes shown with their covers or protective guards removed to illustrate detail. Always replace all covers and protective guards before you use the product.
- If you need a new copy of this manual because it has been lost or damaged, contact your nearest Yaskawa representative or one of the offices listed on the back of this manual.
- This manual is subject to change without notice for product improvements, specifications changes, and improvements to the manual itself. We will update the manual number of the manual and issue revisions when changes are made.
- Any and all quality guarantees provided by Yaskawa are null and void if the customer modifies the product in any way. Yaskawa disavows any responsibility for damages or losses that are caused by modified products.

## **i.6 Warranty**

---

### **i.6.1 Details of Warranty**

---

#### **(1) Warranty Period**

The warranty period for a product that was purchased (hereinafter called the “delivered product”) is one year from the time of delivery to the location specified by the customer or 18 months from the time of shipment from the Yaskawa factory, whichever is sooner.

#### **(2) Warranty Scope**

Yaskawa shall replace or repair a defective product free of charge if a defect attributable to Yaskawa occurs during the above warranty period. This warranty does not cover defects caused by the delivered product reaching the end of its service life and replacement of parts that require replacement or that have a limited service life.

This warranty does not cover failures that result from any of the following causes.

- Improper handling, abuse, or use in unsuitable conditions or in environments not described in product catalogs or manuals, or in any separately agreed-upon specifications
- Causes not attributable to the delivered product itself
- Modifications or repairs not performed by Yaskawa
- Use of the delivered product in a manner in which it was not originally intended
- Causes that were not foreseeable with the scientific and technological understanding at the time of shipment from Yaskawa
- Events for which Yaskawa is not responsible, such as natural or human-made disasters

---

### **i.6.2 Limitations of Liability**

---

- Yaskawa shall in no event be responsible for any damage or loss of opportunity to the customer that arises due to failure of the delivered product.
- Yaskawa shall not be responsible for any programs (including parameter settings) or the results of program execution of the programs provided by the user or by a third party for use with programmable Yaskawa products.
- The information described in product catalogs or manuals is provided for the purpose of the customer purchasing the appropriate product for the intended application. The use thereof does not guarantee that there are no infringements of intellectual property rights or other proprietary rights of Yaskawa or third parties, nor does it construe a license.
- Yaskawa shall not be responsible for any damage arising from infringements of intellectual property rights or other proprietary rights of third parties as a result of using the information described in catalogs or manuals.

---

### **i.6.3 Suitability for Use**

---

- It is the customer’s responsibility to confirm conformity with any standards, codes, or regulations that apply if the Yaskawa product is used in combination with any other products.
- The customer must confirm that the Yaskawa product is suitable for the systems, machines, and equipment used by the customer.
- Consult with Yaskawa to determine whether use in the following applications is acceptable. If use in the application is acceptable, use the product with extra allowance in ratings and specifications, and provide safety measures to minimize hazards in the event of failure.
  - Outdoor use, use involving potential chemical contamination or electrical interference, or use in conditions or environments not described in product catalogs or manuals

- Nuclear energy control systems, combustion systems, railroad systems, aviation systems, vehicle systems, medical equipment, amusement machines, and installations subject to separate industry or government regulations
- Systems, machines, and equipment that may present a risk to life or property
- Systems that require a high degree of reliability, such as systems that supply gas, water, or electricity, or systems that operate continuously 24 hours a day
- Other systems that require a similar high degree of safety
- Never use the product for an application involving serious risk to life or property without first ensuring that the system is designed to secure the required level of safety with risk warnings and redundancy, and that the Yaskawa product is properly rated and installed.
- The circuit examples and other application examples described in product catalogs and manuals are for reference. Check the functionality and safety of the actual devices and equipment to be used before using the product.
- Read and understand all use prohibitions and precautions, and operate the Yaskawa product correctly to prevent accidental harm to third parties.

---

## **i.6.4 Specifications Change**

---

The names, specifications, appearance, and accessories of products in product catalogs and manuals may be changed at any time based on improvements and other reasons. The next editions of the revised catalogs or manuals will be published with updated code numbers. Consult with your Yaskawa representative to confirm the actual specifications before purchasing a product.



# Overview of MECHATROLINK-III Communications

---

1.1	Layers .....	40
1.2	Frame Structure .....	41
1.3	Information on the Extended Address .....	42
1.4	State Transition Diagram .....	43
1.5	Command and Response Timing .....	44
1.5.1	Command Data Execution Timing .....	44
1.5.2	Monitored Data Input Timing .....	44
1.6	List of Commands .....	46
1.6.1	Command Types .....	46
1.6.2	Main Commands .....	46
1.6.3	Subcommands .....	47
1.6.4	Combinations of Main Commands and Subcommands .....	48

## 1.1 Layers

The MECHATROLINK-III communications layers have functions equivalent to layers 1, 2, and 7 in the OSI (Open System Interconnection) reference model.

OSI	MECHATROLINK-III Protocol
Layer 7: Application layer	MECHATROLINK-III application layer
Layers 3 to 6	None
Layer 2: Data link layer	ASIC dedicated to MECHATROLINK-III
Layer 1: Physical layer	Standard Ethernet PHY IEEE 802.3u

This manual describes standard servo profile commands for the application layer.

## 1.2 Frame Structure

A standard servo profile command is composed of the combination of a main command and a subcommand as shown below. It is also possible to use a main command alone.

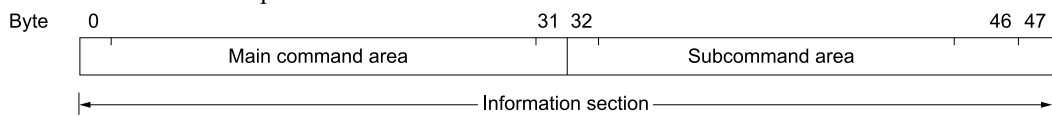

Classifi- cation	Byte	Command	Response
Informa- tion Field	0 to 31	Used by main commands.	
	32 to 47	Used by subcommands. The subcommands for servo commands use byte 33 to byte 48. In some main commands, subcommand cannot be used.	

The application layer interfaces with only the information field.

## 1.3 Information on the Extended Address

If you are using a SERVOPACK that can control multiple servomotors in a single unit (e.g.,  $\Sigma$ -XW SERVOPACK for two-axis control or  $\Sigma$ -XT SERVOPACK for three-axis control), the extended addresses are used to identify the axes.

Axis	Extended Address
Axis A	00h
Axis B	01h
Axis C	02h

# 1.4 State Transition Diagram

The MDevice and SDevice station state transitions are shown in the following diagrams.

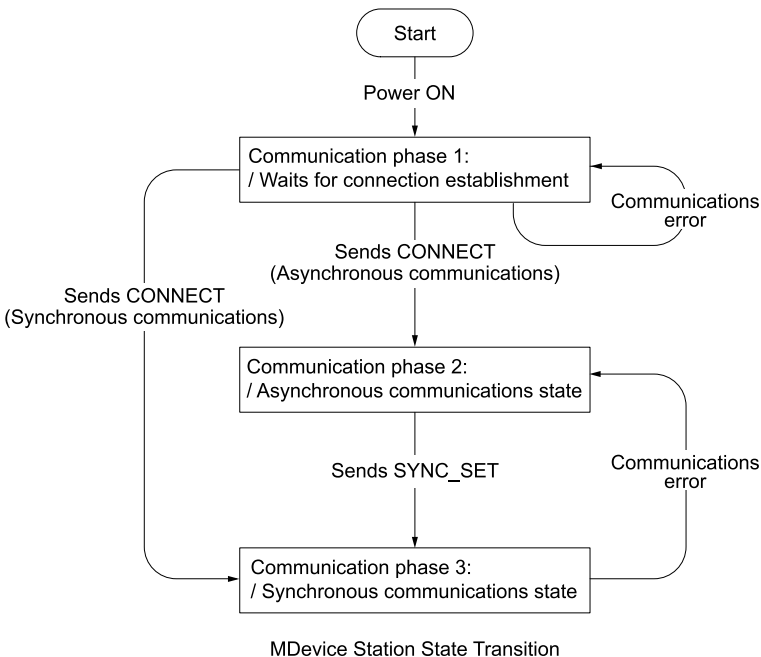

MDevice Station State Transition

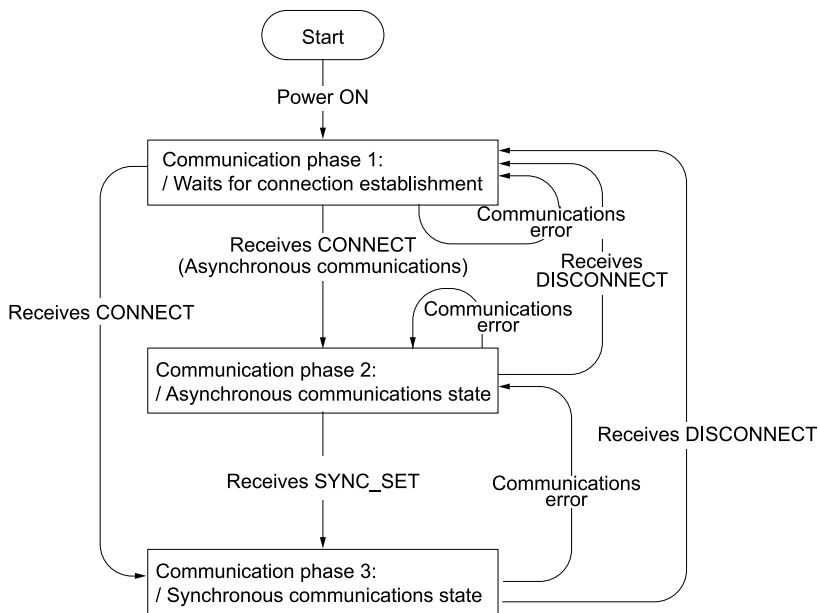

SDevice Station State Transition

Communication Phases	Description
1	Waiting for establishment of connection.
2	Asynchronous communications enabled. Only asynchronous commands can be used.
3	Synchronous communications enabled. Both synchronous and asynchronous commands can be used.

## 1.5 Command and Response Timing

This section describes command execution timing at the SERVOPACK and monitored data input timing at the MDevice station.

These timings are constant, regardless of the transmission cycle and communications cycle.

### 1.5.1 Command Data Execution Timing

There is a delay in the time until the motor starts because motion commands (such as POSING and INTERPOLATE), and the servo command control and servo command I/O signals (SVCMD\_CTRL and SVCMD\_IO) are executed with a slight delay after command reception. The delay time depends on your SERVOPACK. <sup>\*1</sup>

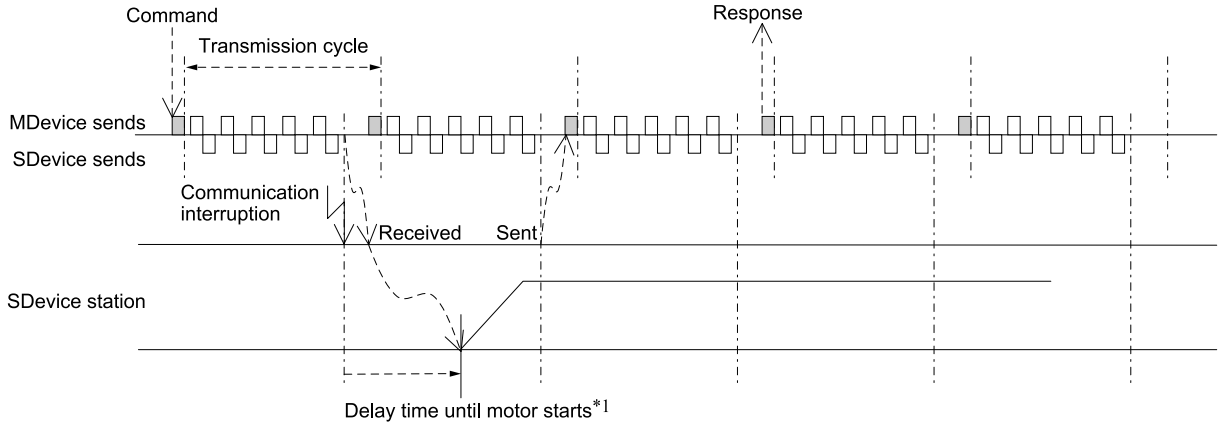

\*1 The time until the motor starts is given below.

SERVOPACK Model	Delay Time until Motor Starts
Σ-7S	About 125 μs
Σ-7W	
Σ-XS	
Σ-XW	
Σ-XT	About 187.5 μs

### 1.5.2 Monitored Data Input Timing

The monitor, I/O, and status data are the data of about 125 μs to 187.5 μs before the response is sent. The time depends on your SERVOPACK. <sup>\*1</sup>

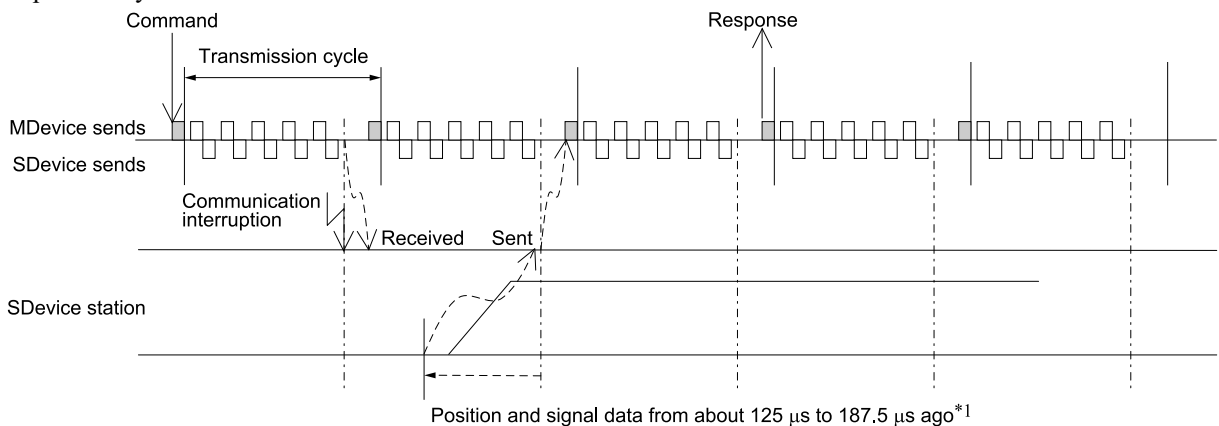

\*1 The data displayed as monitors is given below.

SERVOPACK Model	Data Displayed as Monitors
$\Sigma$ -7S	Data from about 125 $\mu$ s ago
$\Sigma$ -7W	
$\Sigma$ -XS	
$\Sigma$ -XW	
$\Sigma$ -XT	Data from about 187.5 $\mu$ s ago

## 1.6 List of Commands

### 1.6.1 Command Types

MECHATROLINK-III standard servo profile commands are classified into common commands and servo commands.

Common commands: Commands that are common for MECHATROLINK communications, independent of profiles

Servo commands: Commands that are defined in the MECHATROLINK-III standard servo profile and specific to SERVOPACKs

### 1.6.2 Main Commands

The MECHATROLINK-III standard servo profile main commands used for the SERVOPACK are listed below.

#### (1) Common commands

Command Code	Command	Command Name	Function	Reference
00h	NOP	No operation command	Nothing is performed.	81
03h	ID_RD	Read ID command	Reads the device ID.	82
04h	CONFIG	Device setup request command	Enables the current parameter settings.	90
05h	ALM_RD	Read alarm/warning command	Reads the current alarm or warning status, and the alarm history.	92
06h	ALM_CLR	Clear alarm/warning state command	Clears the current alarm or warning status, and the alarm history.	93
0Dh	SYNC_SET	Request for establishing synchronization command	Starts synchronous communications.	94
0Eh	CONNECT	Request for establishing connection command	Requests the establishment of a connection and setting of the communication mode.	95
0Fh	DISCONNECT	Request for releasing connection command	Requests disconnection.	96
1Dh	MEM_RD	Read memory command	Reads data from virtual memory.	97
1Eh	MEM_WR	Write memory command	Writes data to virtual memory.	98

#### (2) Servo Commands

Command Code	Command	Command Name	Function	Reference
20h	POS_SET	Set Coordinates Command	Sets the coordinate system.	101
21h	BRK_ON	Request for applying brake command	Turns the brake signal OFF and applies the holding brake.	102

Continued on next page.

Continued from previous page.

Command Code	Command	Command Name	Function	Reference
22h	BRK_OFF	Release brake command	Turns the brake signal ON and releases the holding brake.	103
23h	SENS_ON	Request for turning sensor ON command	Turns the encoder power supply ON, and gets the position data.	105
24h	SENS_OFF	Request for turning sensor OFF command	Turns the encoder power supply OFF.	105
30h	SMON	Monitor servo status command	Monitors the SERVOPACK status.	106
31h	SV_ON	Servo ON command	Turns the servo of the motor ON.	107
32h	SV_OFF	Servo OFF command	Turns the servo of the motor OFF.	108
34h	INTERPOLATE	Interpolation command	Starts interpolation feeding.	109
35h	POSING	Positioning command	Starts positioning to the target position (TPOS) at the target speed (TSPD).	110
36h	FEED	Constant speed feed command	Starts constant speed feeding at the target speed (TSPD).	112
37h	EX_FEED	Positioning at constant speed by external input command	Starts constant speed feeding at the target speed (TSPD). When an external signal is input part way through, positioning to the specified position is performed from the external signal input position.	114
39h	EX_POSING	Positioning by external input command	Starts positioning to the target position (TPOS) at the target speed (TSPD). When an external signal is input part way through, positioning to the specified position is performed from the external signal input position.	116
3Ah	ZRET	Zero point return command	Performs zero point return.	118
3Ch	VELCTRL	Velocity control command	Controls speed.	121
3Dh	TRQCTRL	Torque control command	Controls torque.	122
40h	SVPRM_RD	Read servo parameter command	Reads the specified servo parameter.	123
41h	SVPRM_WR	Write servo parameter command	Writes the specified servo parameter.	124

### 1.6.3 Subcommands

The MECHATROLINK-III standard servo profile subcommands used for the SERVOPACK are listed below.

Category	Command Code	Command	Command Name	Function	Reference
Servo Commands	00h	NOP	No operation command	Nothing is performed.	<a href="#">130</a>
	05h	ALM_RD	Read alarm/warning command	Reads the current alarm or warning status, and the alarm history.	<a href="#">131</a>
	06h	ALM_CLR	Clear alarm/warning state command	Clears the current alarm or warning status, and the alarm history.	<a href="#">132</a>
	1Dh	MEM_RD	Read memory command	Reads data from virtual memory.	<a href="#">133</a>
	1Eh	MEM_WR	Write memory command	Writes data to virtual memory.	<a href="#">134</a>
	30h	SMON	Monitor servo status command	Monitors the SERVOPACK status.	<a href="#">135</a>
	40h	SVPRM_RD	Read servo parameter command	Reads the specified servo parameter.	<a href="#">136</a>
	41h	SVPRM_WR	Write servo parameter command	Writes the specified servo parameter.	<a href="#">137</a>

#### 1.6.4 Combinations of Main Commands and Subcommands

The combinations of main commands and subcommands are listed below. When an invalid combination is specified, an alarm (SUBCMD\_ALM = Bh (A.95E)) occurs.

For example, if initialization of a parameter is attempted by the MEM\_WR command while sending the SV\_ON command (during the servo ON state), a command error (A.95A) occurs. A command interference error (A.95E) does not occur.

(1)  $\Sigma$ -7 SERVOPACKs

Main Command		Subcommands							
		NOP (00h)	ALM_RD (05h)	ALM_CLR (06h)	MEM_RD (1Dh)	MEM_WR (1Eh)	SMON (30h)	SVPRM_ RD (40h)	SVPRM_ WR (41h)
Com- mon Com- mands	NOP(00h)	○	○	○	○	○	○	○	○
	ID_RD(03h)	○	○	○	○	○	○	○	○
	CONFIG(04h)	○	×	×	×	×	○	×	×
	ALM_RD(05h)	○	×	×	×	×	○	×	×
	ALM_CLR(06h)	○	×	×	×	×	○	×	×
	SYNC_SET(0Dh)	○	×	×	×	×	○	×	×
	CONNECT(0Eh)	○	×	×	×	×	×	×	×
	DISCONNECT(0Fh)	○	×	×	×	×	×	×	×
	MEM_RD(1Dh)	○	×	×	×	×	○	×	×
	MEM_WR(1Eh)	○	×	×	×	×	○	×	×
Servo Com- mands	POS_SET(20h)	○	×	×	×	×	○	×	×
	BRK_ON(21h)	○	×	×	×	×	○	×	×
	BRK_OFF(22h)	○	×	×	×	×	○	×	×
	SENS_ON(23 h)	○	×	×	×	×	○	×	×
	SENS_OFF(24h)	○	×	×	×	×	○	×	×
	SMON(30h)	○	○	○	○	○	○	○	○
	SV_ON(31h)	○	○	○	○	○	○	○	○
	SV_OFF(32h)	○	○	○	○	○	○	○	○
	INTERPOLATE(34h)	○	○	○	○	○	○	○	○
	POSING(35h)	○	○	○	○	○	○	○	○
	FEED(36h)	○	○	○	○	○	○	○	○
	EX_FEED(37h)	○	○	○	○	○	○	○	○
	EX_POSING(39h)	○	○	○	○	○	○	○	○
	ZRET(3Ah)	○	○	○	○	○	○	○	○
	VELCTRL(3Ch)	○	○	○	○	○	○	○	○
	TRQCTRL(3Dh)	○	○	○	○	○	○	○	○
SVPRM_RD(40h)	○	×	×	×	×	○	×	×	
SVPRM_WR(41h)	○	×	×	×	×	○	×	×	

○: Can be combined

×: Cannot be combined

**Information**

Even for a valid combination, a command error (A.95A) occurs if the execution conditions of the commands are not satisfied.

## (2) Σ-X SERVOPACKs

Main Command		Subcommands							
		NOP (00h)	ALM_RD (05h)	ALM_CLR (06h)	MEM_RD (1Dh)	MEM_WR (1Eh)	SMON (30h)	SVPRM_ RD (40h)	SVPRM_ WR (41h)
Common Commands	NOP(00h)	○	○	○	○	○	○	○	○
	ID_RD(03h)	○	○	○	○	○	○	○	○
	CONFIG(04h)	○	×	×	×	×	○	×	×
	ALM_RD(05h)	○	○	○ *1	○	○	○	○	○
	ALM_CLR(06h)	○	×	×	×	×	○	×	×
	SYNC_SET(0Dh)	○	×	×	×	×	○	×	×
	CONNECT(0Eh)	○	×	×	×	×	×	×	×
	DISCONNECT(0Fh)	○	×	×	×	×	×	×	×
	MEM_RD(1Dh)	○	○	○	○	○	○	○	○
	MEM_WR(1Eh)	○	○	○	○	○	○	○	○
Servo Commands	POS_SET(20h)	○	○	○	○	○	○	○	○
	BRK_ON(21h)	○	○	○	○	○	○	○	○
	BRK_OFF(22h)	○	○	○	○	○	○	○	○
	SENS_ON(23 h)	○	×	×	×	×	○	×	×
	SENS_OFF(24h)	○	×	×	×	×	○	×	×
	SMON(30h)	○	○	○	○	○	○	○	○
	SV_ON(31h)	○	○	○	○	○	○	○	○
	SV_OFF(32h)	○	○	○	○	○	○	○	○
	INTERPOLATE(34h)	○	○	○	○	○	○	○	○
	POSING(35h)	○	○	○	○	○	○	○	○
	FEED(36h)	○	○	○	○	○	○	○	○
	EX_FEED(37h)	○	○	○	○	○	○	○	○
	EX_POSING(39h)	○	○	○	○	○	○	○	○
	ZRET(3Ah)	○	○	○	○	○	○	○	○
	VELCTRL(3Ch)	○	○	○	○	○	○	○	○
	TRQCTRL(3Dh)	○	○	○	○	○	○	○	○
SVPRM_RD(40h)	○	○	○	○	○	○	○	○	
SVPRM_WR(41h)	○	○	○	○	○	○	○	○	

○: Can be combined

×: Cannot be combined

\*1 An alarm (command combination error (SUBCMD\_ALM = BH) (= command interference error (A.95E)) will not occur, but the value read with the ALM\_RD command will be indefinite.

**Information** Even for a valid combination, a command error (A.95A) occurs if the execution conditions of the commands are not satisfied.

# Command Format

---

<b>2.1</b>	<b>Common Command Format .....</b>	<b>52</b>
<b>2.2</b>	<b>Command Header Section of Main Command Area .....</b>	<b>53</b>
2.2.1	Command Code (CMD/RCMD) .....	53
2.2.2	Watchdog Data (WDT/RWDT) .....	54
2.2.3	Command Control (CMD_CTRL) .....	55
2.2.4	Command Status (CMD_STAT) .....	56
<b>2.3</b>	<b>Command Header Section of Subcommand Area .....</b>	<b>60</b>
2.3.1	Subcommand Codes (SUBCMD/SUBRCMD) .....	60
2.3.2	Subcommand Control (SUB_CTRL) .....	60
2.3.3	Subcommand Status (SUB_STAT) .....	61
<b>2.4</b>	<b>Servo Command Format .....</b>	<b>62</b>
<b>2.5</b>	<b>Command Header Section .....</b>	<b>63</b>
2.5.1	Servo Command Control (SVCMD_CTRL) .....	63
2.5.2	Servo Command Status (SVCMD_STAT) .....	68
2.5.3	Servo Command I/O Signal (SVCMD_IO) .....	70
<b>2.6</b>	<b>Command Data .....</b>	<b>76</b>
2.6.1	Data Order .....	76
2.6.2	Specifying Units .....	76
2.6.3	Specifying Monitor Data .....	77
2.6.4	Position Data .....	77

## 2.1 Common Command Format

This section describes the specifications that are common for all commands.

The format that is common for the commands sent from the MDevice station and the responses returned from SDevice stations is shown below.

The format of a command can be divided into the main command area (32 bytes) and the subcommand area (16 bytes). The subcommand area is used to supplement the main command with another command. Whether the subcommand area is used or not is determined by the setting of the number of transmission bytes. When the number of transmission bytes is 32, the subcommand area is not used.

Both the main command area and subcommand area are divided into the command header section and the command data section.

- Fields in the command header section of the main command area  
Command: CMD, WDT, CMD\_CTRL  
Response: RCMD, RWDT, CMD\_STAT
- Fields in the command header section of the subcommand area  
Command: SUBCMD, SUB\_CTRL  
Response: RSUBCMD, SUB\_STAT

	Byte	Command	Response	Description
Main Com- mand Area	0	00H	00h	<ul style="list-style-type: none"> <li>• CMD/RCMD: Command code specified for individual commands. Refer to the following section. <a href="#">2.3.1 Subcommand Codes (SUBCMD/SUBRCMD) on page 60</a></li> <li>• WDT/RWDT: Refer to the following section. <a href="#">2.2.2 Watchdog Data (WDT/RWDT) on page 54</a></li> <li>• CMD_CTRL: Refer to the following section. <a href="#">2.2.3 Command Control (CMD_CTRL) on page 55</a></li> <li>• CMD_STAT: Refer to the following section. <a href="#">2.2.4 Command Status (CMD_STAT) on page 56</a></li> <li>• CMD_DATA/RSP_DATA: Specified for individual commands.</li> </ul>
	1	WDT	RWDT	
	2	CMD_CTRL	CMD_STAT	
	3			
	4	CMD_DATA	RSP_DATA	
	5			
	6			
	:			
	29			
	30			
	31			
Subcommand Area	32	SUBCMD	RSUBCMD	<ul style="list-style-type: none"> <li>• SUBCMD/RSUBCMD: Command code specified for individual commands. Refer to the following section. <a href="#">2.3.1 Subcommand Codes (SUBCMD/SUBRCMD) on page 60</a></li> <li>• SUB_CTRL: Refer to the following section. <a href="#">2.3.2 Subcommand Control (SUB_CTRL) on page 60</a></li> <li>• SUB_STAT: Refer to the following section. <a href="#">2.3.3 Subcommand Status (SUB_STAT) on page 61</a></li> <li>• SUB_CMD_DATA/SUB_RSP_DATA: Specified for individual commands. Refer to the following section. <a href="#">4 Subcommands on page 129</a></li> </ul>
	33	SUB_CTRL	SUB_STAT	
	34			
	35			
	36	SUB_CMD_DATA	SUB_RSP_DATA	
	37			
	38			
	:			
	45			
	46			
47				

---

## 2.2 Command Header Section of Main Command Area

This section describes the command header section of the main command area.

---

### 2.2.1 Command Code (CMD/RCMD)

---

This is the command code that defines the meaning of the messaging. Byte 0 of the command format is defined as the CMD/RCMD field. The data set in this field of the response data is a copy of that of the command data.

The following table shows the command codes.

## 2.2 Command Header Section of Main Command Area

Profile	Command Code	Command	Operation	Communication Phases *1		
				1	2	3
Common Commands	00h	NOP	No operation	–	○	○
	01h	PRM_RD *2	Read parameter	–	×	×
	02h	PRM_WR *2	Write parameter	–	×	×
	03h	ID_RD	Read ID	–	○	○
	04h	CONFIG	Device setup request	–	○	○
	05h	ALM_RD	Read alarm/warning	–	○	○
	06h	ALM_CLR	Clear alarm/warning state	–	○	○
	0Dh	SYNC_SET	Request for establishing synchronization	–	○	Δ
	0EH	CONNECT	Request for establishing connection	○	Δ	Δ
	0Fh	DISCONNECT	Request for releasing connection	○	○	○
	1Bh	PPRM_RD *2	Read stored parameter	–	×	×
	1Ch	PPRM_WR *2	Write stored parameter	–	×	×
	1Dh	MEM_RD	Read memory	–	○	○
	1Eh	MEM_WR	Write memory	–	○	○
Servo Commands	20h	POS_SET	Set coordinates	–	○	○
	21h	BRK_ON	Request for applying brake	–	○	○
	22h	BRK_OFF	Release brake	–	○	○
	23h	SENS_ON	Request for turning sensor ON	–	○	○
	24h	SENS_OFF	Request for turning sensor OFF	–	○	○
	30h	SMON	Monitor servo status	–	○	○
	31h	SV_ON	Servo ON	–	○	○
	32h	SV_OFF	Servo OFF	–	○	○
	34h	INTERPOLATE	Interpolation	–	×	○
	35h	POSING	Positioning	–	○	○
	36h	FEED	Constant speed feed	–	○	○
	37h	EX_FEED	Positioning at constant speed by external input	–	○	○
	39h	EX_POSING	Positioning by external input	–	○	○
	3Ah	ZRET	Zero point return	–	○	○
	3Ch	VELCTRL	Velocity control	–	○	○
	3Dh	TRQCTRL	Torque control	–	○	○
	40h	SVPRM_RD	Read servo parameter	–	○	○
41h	SVPRM_WR	Write servo parameter	–	○	○	

\*1 ○: Can be executed, Δ: Ignored, ×: Command error, –: Indefinite response data  
Refer to the following section for details.

 1.4 State Transition Diagram on page 43

\*2 The standard servo command profile does not use PRM\_RD, PRM\_WR, PPRM\_RD and PPRM\_WR, but uses SVPRM\_RD and SVPRM\_WR instead.

## 2.2.2 Watchdog Data (WDT/RWDT)

Byte 1 of the main command is defined as the WDT/RWDT field.

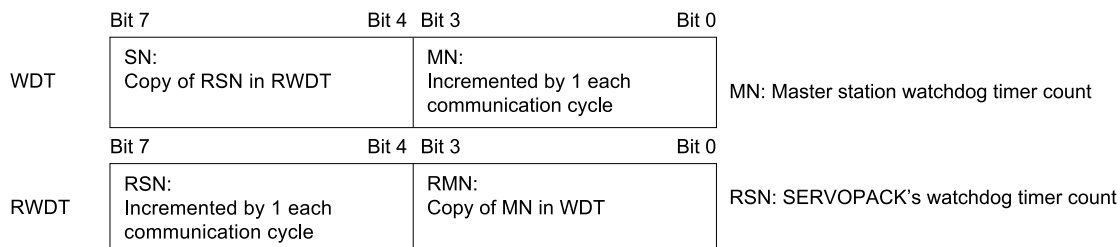

The watchdog data (WDT) is checked after establishing synchronous communications (communications phase 3).

The watchdog data (RWDT) at the SERVOPACK will be refreshed regardless of the establishment of synchronous communications.

## 2.2.3 Command Control (CMD\_CTRL)

The following describes the control data of the main command.

Byte 2 and 3 of the command area of the main command are defined as the CMD\_CTRL field.

The designation in the CMD\_CTRL field is valid even when an alarm specified by CMD\_ALM has occurred.

The CMD\_CTRL field is specified as shown below by the communication specification.

Bit 7	Bit 6	Bit 5	Bit 4	Bit 3	Bit 2	Bit 1	Bit 0
CMD_ID		Reserved.	Reserved.	ALM_CLR	Reserved.	Reserved.	Reserved.

bit 15	Bit 14	Bit 13	Bit 12	Bit 11	Bit 10	Bit 9	Bit 8
Reserved.	Reserved.	Reserved.	Reserved.	Reserved.	Reserved.	Reserved.	Reserved.

### (1) ALM\_CLR: Clear Alarm/Warning State

#### (a) Definition

Clears the alarms and warnings that have occurred in the SERVOPACK.

0: Clear alarm/warning disabled

1: Clear alarm/warning triggered

#### (b) Description

Clears the alarm/warning state at the leading edge.

The same processing as when ALM\_CLR\_MOD = 0 for the ALM\_CLR command (the currently occurring alarm/warning state is cleared) is performed.

### (2) CMD\_ID: Command ID

#### (a) Definition

The MDevice station uses the command ID to have as SDevice station acknowledge that the command is a new command when the MDevice station sends the same command repeatedly to the SDevice station.

Applicable commands: EX\_FEED, EX\_POSING, ZRET

A value in the range 0 to 3 is used.

#### (b) Description

The SDevice station returns the CMD\_ID of the command being executed. The SDevice station can decisively judge the command for which the SDevice station sent the response.

While CMDRDY = 0 (command reception disabled), the SDevice station disregards commands that have a different CMD\_ID and continues the execution of the command being executed.

## 2.2.4 Command Status (CMD\_STAT)

The following describes the status of main command responses.

Byte 2 and 3 of the response area of the main command are defined as the CMD\_STAT field.

The CMD\_STAT field is specified as shown below by the communication specification.

Bit 7	Bit 6	Bit 5	Bit 4	Bit 3	Bit 2	Bit 1	Bit 0
RCMD_ID		Reserved.	Reserved.	ALM_CLR_CMP	CMDRDY	D_WAR	D_ALM
bit 15	Bit 14	Bit 13	Bit 12	Bit 11	Bit 10	Bit 9	Bit 8
COMM_ALM				CMD_ALM			

### (1) D\_ALM

#### (a) Definition

This bit indicates the device alarm state of the SDevice station.

1: A device-specific alarm has occurred.

0: Other state (normal state, or the alarm specified by COMM\_ALM or CMD\_ALM has occurred.)

#### (b) Description

- When a device-specific alarm other than the alarm state specified by COMM\_ALM and CMD\_ALM has occurred, the D\_ALM status bit is set to "1." D\_ALM is independent of COMM\_ALM and CMD\_ALM.
- When a device-specific alarm has occurred and D\_ALM is set to "1" in the servo ON state, the servo OFF state is established.
- When the SDevice station shifts from the alarm state to the normal state as a result of the execution of the ALM\_CLR command or CMD\_CTRL.ALM\_CLR, this bit is set to "0."

< Example > Device alarm: Position Deviation Overflow (A.D00) → D\_ALM = 1

### (2) D\_WAR

#### (a) Definition

This bit indicates the device warning state of the SDevice station.

1: A device-specific warning has occurred.

0: Other state (normal state, or the alarm specified by COMM\_ALM or CMD\_ALM has occurred.)

#### (b) Description

- When a device-specific warning other than the warning state specified by COMM\_ALM or CMD\_ALM has occurred, the D\_WAR status bit is set to "1." D\_WAR is independent of COMM\_ALM and CMD\_ALM.
- When a device-specific warning has occurred and the D\_WAR status bit is set to "1" in the servo ON state, the servo ON state is retained.
- When the SDevice station shifts from the warning state to the normal state as a result of the execution of the ALM\_CLR command or CMD\_CTRL.ALM\_CLR, D\_WAR is set to "0."

< Example > Device warning: Overload Warning (A.910) → D\_WAR = 1

### (3) CMDRDY

#### (a) Definition

This bit indicates whether the SDevice station is ready to receive commands.

1: Command reception enabled

0: Command reception disabled

**(b) Description**

- CMDRDY = 0 means that command processing is in progress. While CMDRDY = 0, the SDevice station continues to process the current command, but the SDevice station will discard new commands received while CMDRDY = 0.  
Only the DISCONNECT command is executed immediately regardless of the CMDRDY value.
- Completion of command execution is confirmed in accordance with the completion confirmation method of each command.
- The hold time for CMDRDY = 0 is specified for each command.
- If command execution is possible despite an alarm or warning state, CMDRDY is set to "1."

**(4) ALM\_CLR\_CMP****(a) Definition**

This bit indicates the execution state of the CMD\_CTRL.ALM\_CLR command.

1: CMD\_CTRL.ALM\_CLR execution completed

0: Other

**(b) Description**

- ALM\_CLR\_CMP is set to "1" in the following cases.
  - When the alarm clear processing executed by the CMD\_CTRL.ALM\_CLR command has been completed.  
ALM\_CLR\_CMP is set to "1" when the alarm cannot be cleared as well.
  - When the alarm clear processing time (approx. 200 ms) has elapsed after receiving the CMD\_CTRL.ALM\_CLR command.  
ALM\_CLR\_CMP is set to "1" when the alarm cannot be cleared as well.
- ALM\_CLR\_CMP can be cancelled by setting "0" for CMD\_CTRL.ALM\_CLR.

**(5) RCMD\_ID****(a) Definition**

This is the echo-back of CMD\_CTRL.CMD\_ID.

**(b) Description**

- This is the identification code of the same commands that the SDevice station has received contiguously.
- Returns the CMD\_ID of the command format.

**(6) CMD\_ALM****(a) Definition**

This bit indicates the validation result of the command.

**(b) Description**

- CMD\_ALM indicates whether the command is valid or not. The results of validations of the command codes, and the combinations of commands and the data in the command frame are notified.
- COMM\_ALM is independent of D\_ALM and D\_WAR.
- If a normal command is received after the occurrence of a command error, CMD\_ALM is automatically cleared.
- The phase doesn't change even if the status of CMD\_ALM is not "0." The servo ON/OFF state doesn't change either.

Code		Description	Remarks
Normal	0	Normal	–
Warning	1	Invalid data	The SDevice station notifies the warning state. It operates at the specified value or the value on clamping at the maximum or minimum value.
	2	–	
	3	–	
	4	–	
	5	–	
	6	–	
	7	–	
Alarm	8	Unsupported command received	The SDevice station notifies the alarm state. The command is not executed.
	9	Invalid data	
	A	Command execution condition error	
	B	Subcommand combination error	
	C	Phase error	
	D	–	
	E	–	
	F	–	

< Example > Command error: Data Setting Warning 2 (A.94B) → CMD\_ALM = 9h



Check the status of CMD\_ALM with the host controller for every communication cycle and perform appropriate processing because CMD\_ALM will be automatically cleared.

Important

## (7) COMM\_ALM

### (a) Definition

This bit indicates the MECHATROLINK communications error status.

### (b) Description

- COMM\_ALM shows if the data transmission in the physical or application layer has completed normally or not.
- COMM\_ALM is independent of CMD\_ALM, D\_ALM and D\_WAR.
- COMM\_ALM is cleared by the ALM\_CLR command or CMD\_CTRL.ALM\_CLR.

Code		Description	Remarks
Normal	0	Normal	–
Warning	1	FCS error	Occurs when an error is detected once.
	2	Command data not received	The servo ON state is retained when an error is detected in the servo ON state.
	3	Synchronous frame not received	Error detection method
	4	–	1: FCS error
	5	–	The SERVOPACK detects FCS errors.
	6	–	2: Command data not received
	7	–	The SERVOPACK detects that command data has not been received. 3: Synchronous frame not received The SERVOPACK detects that the synchronous frame has not been received.

Continued on next page.

Continued from previous page.

Code		Description	Remarks
Alarm	8	FCS error	Occurs when an error is detected in the following detection methods. Error detection method 8, 9, A: Set if an error is detected twice consecutively using the error detection method for warnings 1, 2 and 3 described above. B, C: Set immediately upon occurrence of a single error. The following occur after error detection. • If the system is in communication phase 3, it will shift to communication phase 2. After shifting to communication phase 2, first remove the cause of the error, and then send the SYNC_SET command and restart synchronous communications. • The servo will turn OFF.
	9	Command data not received	
	A	Synchronous frame not received	
	B	Synchronization interval error	
	C	WDT error	
	D	–	
	E	–	
F	–		

&lt;Example&gt;

Communications error (warning): MECHATROLINK Communications Warning (A.960) → COMM\_ALM = 2h

Communications error (alarm): Reception Error in MECHATROLINK Communications (A.E60) → COMM\_ALM = 9h

## 2.3 Command Header Section of Subcommand Area

Subcommands use byte 32 to byte 47 of the data field and function as a supplementary command to the main command. This subsection describes the command header of the subcommand area.

### 2.3.1 Subcommand Codes (SUBCMD/SUBRCMD)

This is the subcommand code that specifies the meaning of the subcommand messaging. Byte 32 of the command format is defined as the SUBCMD/SUBRCMD field. The data set in this field of the response data is a copy of that of the command data.

The following table shows the command codes of the subcommand.

Profile	Command Code	Command	Operation	Communication Phases <sup>*1</sup>		
				1	2	3
Servo Commands	00h	NOP	No operation	–	○	○
	05h	ALM_RD	Read alarm/warning	–	○	○
	06h	ALM_CLR	Clear alarm/warning state	–	○	○
	1Dh	MEM_RD	Read memory command	–	○	○
	1Eh	MEM_WR	Write memory command	–	○	○
	30h	SMON	Monitor servo status	–	○	○
	40h	SVPRM_RD	Read servo parameter	–	○	○
	41h	SVPRM_WR	Write servo parameter	–	○	○

\*1 ○: Can be executed, Δ: Ignored, ×: Command error, –: Indefinite response data

### 2.3.2 Subcommand Control (SUB\_CTRL)

The following describes the subcommand control data.

Byte 33 to byte 35 of the command format are specified as the SUB\_CTRL field.

The SUB\_CTRL field is specified as shown below by the communication specification.

#### (1) SUB\_CTRL Field

Bit 7	Bit 6	Bit 5	Bit 4	Bit 3	Bit 2	Bit 1	Bit 0
Reserved.		Reserved.		Reserved.			
Bit 15	Bit 14	Bit 13	Bit 12	Bit 11	Bit 10	Bit 9	Bit 8
SEL_MON4				Reserved.			
Bit 23	Bit 22	Bit 21	Bit 20	Bit 19	Bit 18	Bit 17	Bit 16
SEL_MON6				SEL_MON5			

#### (2) Details of Control Bits

The following table shows the details of the control bits.

Bit	Name	Description	Value	Setting
12 to 15	SEL_MON4	Monitor Selection 4	0 to 15	Selects the monitor information with the setting value. Refer to the following section for details on the settings. <a href="#">2.6.3 Specifying Monitor Data on page 77</a>
16 to 19	SEL_MON5	Monitor Selection 5	0 to 15	
20 to 23	SEL_MON6	Monitor Selection 6	0 to 15	

### 2.3.3 Subcommand Status (SUB\_STAT)

The following describes the status of subcommand responses.

Byte 33 to 35 of the response area of the subcommand are defined as the SUB\_STAT field.

The SUB\_STAT field is specified as shown below by the communication specification.

#### (1) SUB\_STAT Field

Bit 7	Bit 6	Bit 5	Bit 4	Bit 3	Bit 2	Bit 1	Bit 0
Reserved.		Reserved.		Reserved.	SUBCMDRDY	Reserved.	Reserved.
Bit 15	Bit 14	Bit 13	Bit 12	Bit 11	Bit 10	Bit 9	Bit 8
SEL_MON4				SUBCMD_ALM			
Bit 23	Bit 22	Bit 21	Bit 20	Bit 19	Bit 18	Bit 17	Bit 16
SEL_MON6				SEL_MON5			

#### (2) Details of Status Bits

The following table shows the details of the status bits.

Bit	Name	Description	Value	Setting
2	SUBCMDRDY <sup>*</sup> 1	Subcommand Ready	1	Subcommand reception enabled
			0	Other than above
8 to 11	SUBCMD_ALM	Subcommand Alarm	0 to 15	Refer to the following section. <a href="#">2.2.4 Command Status (CMD_STAT) on page 56</a>
12 to 15	SEL_MON4	Monitor Selection 4	0 to 15	The status used to judge the data currently being monitored as the monitor information of the response data A copy of the command is displayed here.
16 to 19	SEL_MON5	Monitor Selection 5	0 to 15	
20 to 23	SEL_MON6	Monitor Selection 6	0 to 15	The monitor information is displayed in the MONITOR4 to 6 fields of the response area.

\*1 When no subcommand is used, the SUBCMDRDY status bit is set to "1."

## 2.4 Servo Command Format





This section describes the specifications of the servo commands.

The servo commands are specified by the 32-byte command and response data in the communication specifications as shown in the table below.

The command/response data area can be expanded to 48 bytes by using subcommands. For the subcommands, refer to the following chapter.

 [4 Subcommands on page 129](#)

The following table shows the format of the servo command and response data.

Byte	Command	Response	Description
0	CMD	RCMD	<ul style="list-style-type: none"> <li>• CMD_CTRL: Refer to the following section.  <a href="#">2.2.3 Command Control (CMD_CTRL) on page 55</a></li> <li>• CMD_STAT: Refer to the following section.  <a href="#">2.2.4 Command Status (CMD_STAT) on page 56</a></li> <li>• SVCMD_CTRL: Refer to the following section.  <a href="#">2.5.1 Servo Command Control (SVCMD_CTRL) on page 63</a></li> <li>• SVCMD_STAT: Refer to the following section.  <a href="#">2.5.2 Servo Command Status (SVCMD_STAT) on page 68</a></li> <li>• SVCMD_IO: Refer to the following section.  <a href="#">2.5.3 Servo Command I/O Signal (SVCMD_IO) on page 70</a></li> <li>• CMD_DATA/RSP_DATA: Specified for individual commands.</li> </ul>
1	WDT	RWDT	
2	CMD_CTRL	CMD_STAT	
3			
4	SVCMD_CTRL	SVCMD_STAT	
5			
6			
7			
8	SVCMD_IO	SVCMD_IO	
9			
10			
11			
12	CMD_DATA	POS_SET_MOD	
13			
14			
:			
29			
30			
31			

## 2.5 Command Header Section

For the details of the command header section (command code, watchdog data and command control fields), refer to the following section.

☞ [2.2 Command Header Section of Main Command Area on page 53](#)

### 2.5.1 Servo Command Control (SVCMD\_CTRL)

The following describes the servo command control data.

Byte 4 to 7 of the command area of the servo command are defined as the SVCMD\_CTRL field. The control bit specifies a motion command for an SDevice station.

The SVCMD\_CTRL field contains auxiliary data for the specified command and the control bits have no meaning with commands other than the command that specified the data.

Note that the commands in this field are valid even when a CMD\_ALM has occurred.

The SVCMD\_CTRL field is specified as shown below by the communications specification.

#### (1) SVCMD\_CTRL Field

Bit 7	Bit 6	Bit 5	Bit 4	Bit 3	Bit 2	Bit 1	Bit 0
Reserved (0)		ACCFIL		STOP_MODE		CMD_CANCEL	CMD_PAUSE
Bit 15	Bit 14	Bit 13	Bit 12	Bit 11	Bit 10	Bit 9	Bit 8
Reserved (0)		LT_SEL2		LT_SEL1		LT_REQ2	LT_REQ1
Bit 23	Bit 22	Bit 21	Bit 20	Bit 19	Bit 18	Bit 17	Bit 16
SEL_MON2				SEL_MON1			
Bit 31	Bit 30	Bit 29	Bit 28	Bit 27	Bit 26	Bit 25	Bit 24
Reserved (0)				SEL_MON3			

#### (2) Details of Control Bits

The following table shows the details of the control bits.

Bit	Name	Description	Value	Setting	Enabled Timing
0	CMD_PAUSE	Pause of Move Command	0	None	Level
			1	Move command pause command	
Pauses execution of the POSING, FEED, EX_FEED, EX_POSING, ZRET, and VELCTRL commands according to the SVCMD_CTRL.STOP_MODE setting.					
1	CMD_CANCEL	Cancellation of Move Command	0	None	Level
			1	Cancellation of move command	
Cancels execution of the POSING, FEED, EX_FEED, EX_POSING, ZRET, and VELCTRL commands according to the SVCMD_CTRL.STOP_MODE setting.					
2, 3	STOP_MODE	Selection of Stop Mode	0	Stop after deceleration	Level
			1	Immediate stop	
			2	Reserved.	
			3	Reserved.	
Selects the stop mode for SVCMD_CTRL.CMD_PAUSE and SVCMD_CTRL.CMD_CANCEL.					

Continued on next page.

Bit	Name	Description	Value	Setting	Enabled Timing
4, 5	ACCFIL	Selection of Position Reference Filter	0	No position reference filter	Level
			1	Exponential function position reference filter	
			2	Movement average position reference filter	
			3	Reserved.	
To be set when specifying the position reference filter.					
8	LT_REQ1	Latch Request 1	0	None	Leading edge
			1	Request for latch	
Requests latch by the phase C or an external input signal.					
9	LT_REQ2	Latch Request 2	0	None	Leading edge
			1	Request for latch	
Requests latch by the phase C or an external input signal. This can be used as the continuous latch mode as well.					
10, 11	LT_SEL1	Latch Signal Select 1	0	Phase C	Leading edge of LT_REQ1
			1	External input signal 1	
			2	External Input Signal 2	
			3	External Input Signal 3	
Selects the phase C or the external input signal for SVCMD_CTRL.LT_REQ1. Make a setting different from SVCMD_CTRL.LT_SEL2. However, if you will use the $\Sigma$ -7F integrated servomotor (Model: SGF7□-□□□□□□□□2□), set LT_SEL1 and LT_SEL2 to phase C. <b>【Important】</b> The $\Sigma$ -7F integrated servomotor (Model: SGF7□-□□□□□□□□2□) supports phase C only. This setting is disabled when the control bits are set to external input signal 1, 2, or 3.					
12, 13	LT_SEL2	Latch Signal Select 2	0	Phase C	Leading edge of LT_REQ2
			1	External Input Signal 1	
			2	External Input Signal 2	
			3	External Input Signal 3	
Selects the phase C or the external input signal for SVCMD_CTRL.LT_REQ2. Make a setting different from SVCMD_CTRL.LT_SEL1. However, if you will use the $\Sigma$ -7F integrated servomotor (Model: SGF7□-□□□□□□□□2□), set LT_SEL1 and LT_SEL2 to phase C. When the continuous latch mode is selected, this setting will be ignored since the signal set with the parameter is used. <b>【Important】</b> The $\Sigma$ -7F integrated servomotor (Model: SGF7□-□□□□□□□□2□) supports phase C only. This setting is disabled when the control bits are set to external input signal 1, 2, or 3.					
16 to 19	SEL_MON1	Monitor Selection 1	0 to 15	Monitor selection	Level
20 to 23	SEL_MON2	Monitor Selection 2	0 to 15	Monitor selection	Level
24 to 27	SEL_MON3	Monitor Selection 3	0 to 15	Monitor selection	Level

### (3) Supplementary Information on SVCMD\_CTRL.CMD\_PAUSE and SVCMD\_CTRL.CMD\_CANCEL

#### (a) SVCMD\_CTRL.CMD\_PAUSE (Pausing a Command Operation)

- SVCMD\_CTRL.CMD\_PAUSE is used to pause motion command operation. (Motion command processing continues. Motion command operation can be resumed by clearing CMD\_PAUSE.)
- SVCMD\_CTRL.CMD\_PAUSE is valid only when the POSING, FEED, EX\_FEED, EX\_POSING, ZRET, and VELCTRL commands are operating.

#### ◆ Pausing Procedure

Step	Operation	Remarks
1	The MDevice station sets "1" (immediate stop) for SVCMD_CTRL.STOP_MODE and "1" (move command pause command) for SVCMD_CTRL.CMD_PAUSE and transmits one of the motion commands given above.	—
2	The SDevice station stops in accordance with SVCMD_CTRL.STOP_MODE.	When "0" (stop after deceleration) is set for SVCMD_CTRL.STOP_MODE, the SDevice station decelerates at the value set for the DECR (deceleration) field.
3	When SVCMD_CTRL.CMD_PAUSE becomes "1" (move command pause command) and SVCMD_IO.ZSPD becomes "1" (zero speed detected), the SDevice station sets SVCMD_STAT.CMD_PAUSE_CMP to "1" (pausing of move command completed).	Even after stopping, the SDevice station maintains the previous control mode and SVCMD_IO.DEN remains at "0" (during distribution) (in the position control mode).



Important

- SVCMD\_CTRL.CMD\_PAUSE is disregarded for commands for which CMD\_PAUSE is not valid, and SVCMD\_STAT.CMD\_PAUSE\_CMP remains "0" (incomplete).
- When using SVCMD\_CTRL.CMD\_PAUSE, execute the relevant motion command continuously until SVCMD\_STAT.CMD\_PAUSE\_CMP becomes "1" (pausing of move command completed).
- By setting "0" (none) for SVCMD\_CTRL.CMD\_PAUSE, the pausing operation is canceled and the motion command operation is resumed.

#### ◆ Example of Pausing the POSING Command

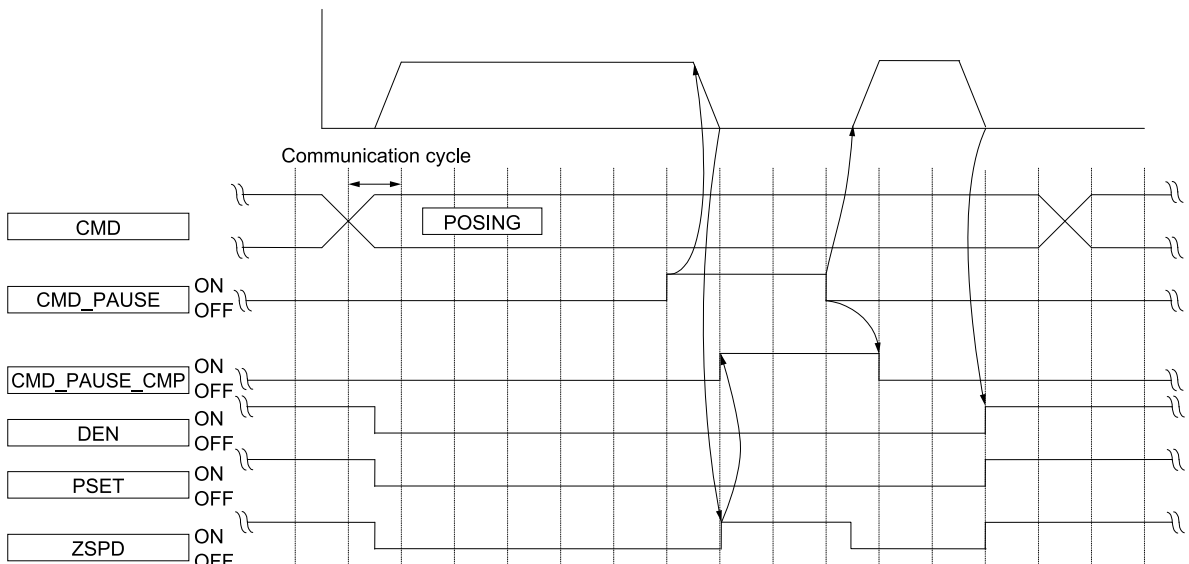

◆ Example of Pausing the VELCTRL Command

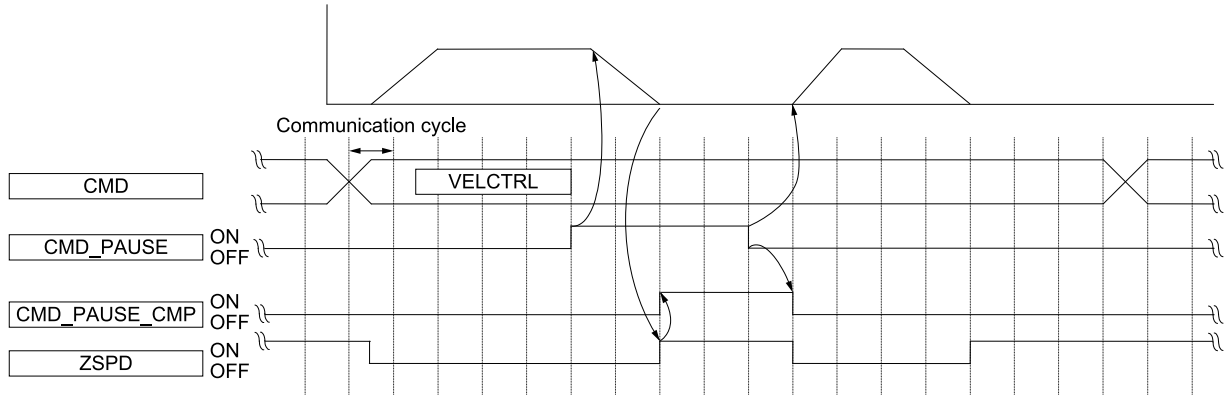

(b) SVCMD\_CTRL.CMD\_CANCEL (Canceling a Command Operation)

- SVCMD\_CTRL.CMD\_CANCEL is used to interrupt motion command operation. (Motion command processing is cleared.)
- SVCMD\_CTRL.CMD\_CANCEL is valid only when the POSING, FEED, EX\_FEED, EX\_POSING, ZRET, and VELCTRL commands are operating.

◆ Canceling Procedure

Step	Operation	Remarks
1	The MDevice station sets "1" (immediate stop) for SVCMD_CTRL.STOP_MODE and "1" (cancellation of move command) for SVCMD_CTRL.CMD_CANCEL and transmits one of the motion commands given above.	-
2	The SDevice station stops in accordance with SVCMD_CTRL.STOP_MODE.	When "0" (stop after deceleration) is set for SVCMD_CTRL.STOP_MODE, the SDevice station decelerates at the value set for the DECR (deceleration) field.
3	"1" (cancellation of move command completed) is set for SVCMD_STAT.CMD_CANCEL_CMP at the SDevice station in the following circumstances.	In the position control mode: When SVCMD_CTRL.CMD_CANCEL becomes "1" (cancellation of move command) and SVCMD_IO.DEN becomes "1" (distribution completed). In the speed control mode: When SVCMD_CTRL.CMD_CANCEL becomes "1" (cancellation of move command) and ZSPD becomes "1" (zero speed detected). Even after stopping, the SDevice station maintains the previous control mode.



Important

- SVCMD\_CTRL.CMD\_CANCEL is disregarded for commands for which CMD\_CANCEL is not valid, and SVCMD\_STAT.CMD\_CANCEL\_CMP remains "0" (incomplete).
- When SVCMD\_CTRL.CMD\_PAUSE and CMD\_CANCEL are simultaneously turned ON or when CMD\_CANCEL is turned ON after CMD\_PAUSE, CMD\_CANCEL takes priority.
- When using SVCMD\_CTRL.CMD\_CANCEL, execute the relevant motion command continuously until SVCMD\_STAT.CMD\_CANCEL\_CMP becomes "1" (cancellation of move command completed).
- By setting "0" (none) for SVCMD\_CTRL.CMD\_CANCEL, the cancellation operation is canceled and the motion command is processed as a new motion command.

◆ Example of Canceling the POSING Command

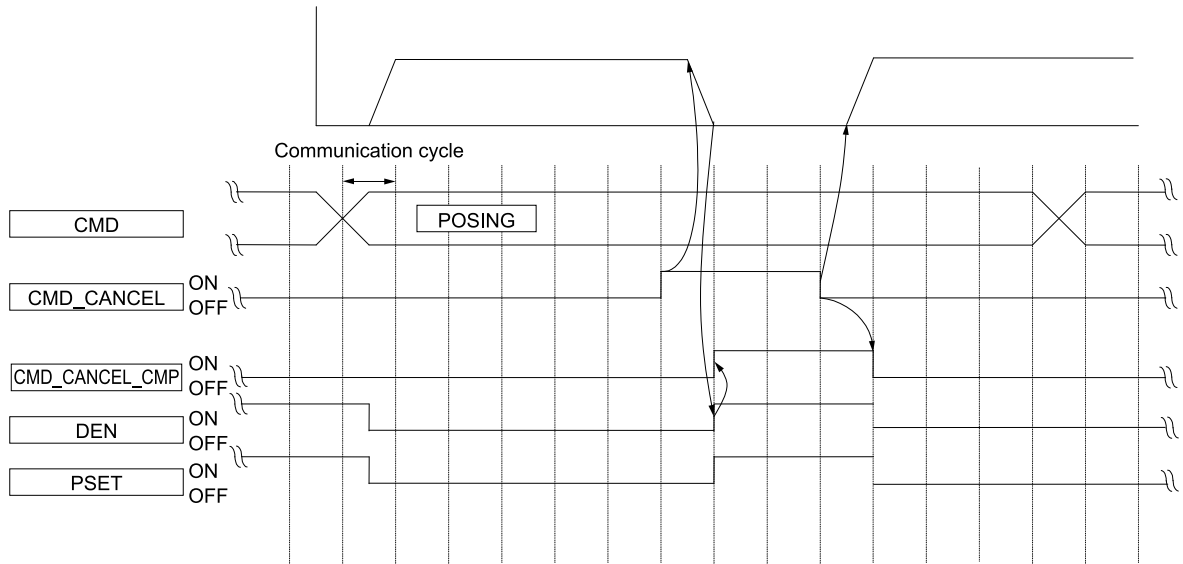

◆ Example of Canceling the VELCTRL Command

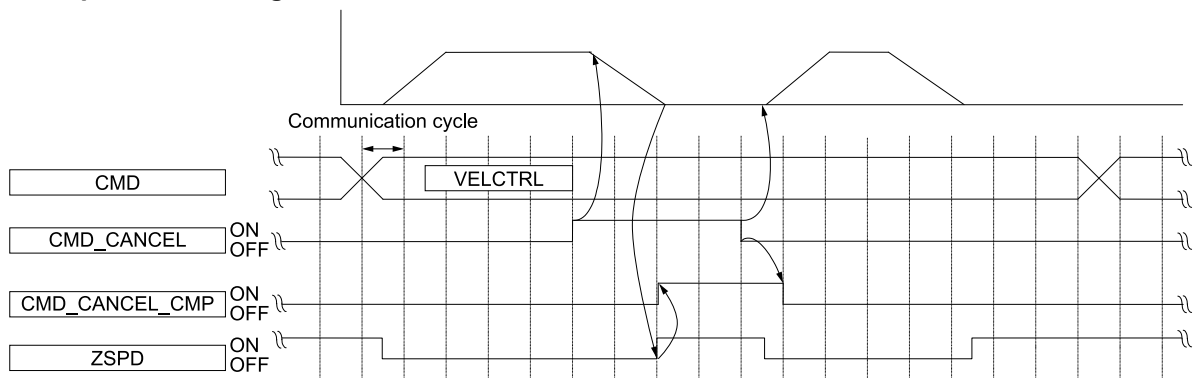

(4) Supplementary Information on Latching Operation

The latch operation is enabled at the leading edge of SVCMD\_CTRL.LT\_REQ1 and SVCMD\_CTRL.LT\_REQ2. The operations to be performed when commands are changed after enabling the latch operation are specified in the table below. (The value of SVCMD\_CTRL.LT\_SEL is an example.)

Command before Switching	Command after Switching	Latch Operation
Command without a latch function LT_SEL = 1 LT_REQ = 1	Common commands	Continues the latch request before switching.
Command with a latch function LT_SEL = 1 LT_REQ = 1	Common commands	Interrupts operation as a command with a latch function.
Command without a latch function LT_SEL = 1 LT_REQ = 1	Command without a latch function LT_SEL = 1 LT_REQ = 1	Continues the latch request before switching.
Command without a latch function LT_SEL = 1 LT_REQ = 1	Command without a latch function LT_SEL = 2 LT_REQ = 1	Continues the latch request before switching.

Continued on next page.

Command before Switching	Command after Switching	Latch Operation
Command without a latch function LT_SEL = 1 LT_REQ = 1	Command with a latch function LT_SEL = 1 LT_REQ = 1	Switches to a latch request for the command after switching. The servo drive executes another latch request. (Internal processing) If the status "L_CMP = 1" is established before command switching, then the status is set to "L_CMP = 0" at command switching.
Command with a latch function LT_SEL = 1 LT_REQ = 1	Command without a latch function LT_SEL = 1 LT_REQ = 1	Switches to a latch request for the command after switching. The servo drive executes another latch request. (Internal processing) If the status "L_CMP = 1" is established before command switching, then the status is set to "L_CMP = 0" at command switching.
Command with a latch function LT_SEL = 1 LT_REQ = 1	Command with a latch function LT_SEL = 1 LT_REQ = 1	Switches to a latch request for the command after switching. The servo drive executes another latch request. (Internal processing) If the status "L_CMP = 1" is established before command switching, then the status is set to "L_CMP = 0" at command switching.

**Note:**

- Command with a latch function: EX\_FEED, EX\_POSING, ZRET  
 Commands without a latch function: POS\_SET, BRK\_ON, BRK\_OFF, SENS\_ON, SENS\_OFF, SMON, SV\_ON, SV\_OFF, INTERPOLATE, POSING, FEED, VELCTRL, TRQCTRL, SVPRM\_RD, SVPRM\_WR  
 Common commands: NOP, ID\_RD, CONFIG, ALM\_RD, ALM\_CLR, SYNC\_SET, CONNECT, DISCONNECT, MEM\_RD, MEM\_WR
- LT\_SEL:LT\_SEL1 or LT\_SEL2  
 LT\_REQ:LT\_REQ1 or LT\_REQ2

## 2.5.2 Servo Command Status (SVCMD\_STAT)

The following describes the status of servo command responses.

Byte 4 to 7 of the response area of the servo command are defined as the SVCMD\_STAT field. The status bit indicates the status of the SDevice station.

Note that the designation in this field is valid even when a CMD\_ALM has occurred.

The SVCMD\_STAT field is specified as shown below by the communication specification.

### (1) SVCMD\_STAT Field

Bit 7	Bit 6	Bit 5	Bit 4	Bit 3	Bit 2	Bit 1	Bit 0
Reserved (0)		ACCFIL		Reserved (0)		CMD_CAN- CEL_CMP	CMD_PAUSE_ CMP
bit 15	Bit 14	Bit 13	Bit 12	Bit 11	Bit 10	Bit 9	Bit 8
Reserved (0)		SV_ON	M_RDY	PON	POS_RDY	L_CMP2	L_CMP1
Bit 23	Bit 22	Bit 21	Bit 20	Bit 19	Bit 18	Bit 17	Bit 16
SEL_MON2				SEL_MON1			
Bit 31	Bit 30	Bit 29	Bit 28	Bit 27	Bit 26	Bit 25	Bit 24
Reserved (0)				SEL_MON3			

### (2) Details of Status Bits

The following table shows the details of the status bits.

Bit	Name	Description	Value	Setting
0	CMD_PAUSE_CMP	Completion of Pause of Move Command	0	Incomplete (when pausing commanded)
			1	Pausing of move command completed
	The status used to judge the completion of pausing of the POSING, FEED, EX_FEED, EX_POSING, ZRET and VELCTRL commands			
1	CMD_CANCEL_CMP	Completion of Cancellation of Move Command	0	Incomplete (when cancellation commanded)
			1	Cancellation of Move Command Completed
	The status used to judge the completion of cancellation of the POSING, FEED, EX_FEED, EX_POSING, ZRET and VELCTRL commands			
4, 5	ACCFIL	Current Position Reference Filter	0	No position reference filter
			1	Exponential function position reference filter
			2	Movement average position reference filter
			3	Reserved.
	The status used to judge the position reference filter currently being applied			
8	L_CMP1	Latch Completion 1	0	Latch not completed
			1	Latch completed
	The status used to judge the completion of latching requested by SVCMD_CTRL.LT_REQ1. Up until "0" is set for LT_REQ1, L_CMP1 is maintained at "1."			
9	L_CMP2	Latch Completion 2	0	Latch not completed
			1	Latch completed
	The status used to judge the completion of latching requested by SVCMD_CTRL.LT_REQ2. Up until "0" is set for LT_REQ2, L_CMP2 is maintained at "1." In the continuous latch mode, L_CMP2 is returned to "0" after one communication cycle after completing latching.			
10	POS_RDY	Position Data Enabled	0	Disabled
			1	Enabled
	The status used to judge if the position data currently being monitored as the monitor information of the response data is valid. When an incremental encoder is used: "1" is set after completion of executing the CONNECT command. When an absolute encoder is used: "1" is set on completion of the SENS_ON command and "0" is set on completion of the SENS_OFF or CONFIG command. When position data cannot be obtained properly due to an encoder error, "0" is set.			
11	PON	Power ON	0	Power OFF
			1	Power ON
The status used to judge if the power is turned ON or not				
12	M_RDY	Motor Energization Ready	0	Not ready
			1	Ready
The status used to judge if the servo can be turned ON or not				
13	SV_ON	Servo ON	0	Servo OFF
			1	Servo ON
The status used to judge if the motor is energized or not				
16 to 19	SEL_MON1	Monitor Selection 1: Returns what data is being monitored.	0 to 15	Monitor selection
			The status used to judge the data currently being monitored as the monitor information of the response data A copy of the command is displayed here. The monitor information is displayed in the MONITOR1 field of the response area.	

Continued on next page.

Bit	Name	Description	Value	Setting
20 to 23	SEL_MON2	Monitor Selection 2: Returns what data is being monitored.	0 to 15	Monitor selection
	The status used to judge the data currently being monitored as the monitor information of the response data A copy of the command is displayed here. The monitor information is displayed in the MONITOR2 field of the response area.			
24 to 27	SEL_MON3	Monitor Selection 3: Returns what data is being monitored.	0 to 15	Monitor selection
	The status used to judge the data currently being monitored as the monitor information of the response data A copy of the command is displayed here. The monitor information is displayed in the MONITOR3 field of the response area.			

### 2.5.3 Servo Command I/O Signal (SVCMD\_IO)

This section describes the servo command I/O signal monitoring.

#### (1) Bit Allocation of Servo Command Output Signals

Byte 8 to 11 of the command area of the servo command are defined as the SVCMD\_IO field. The servo command output signals are signals output to the SDevice station.

Note that the commands in this field are valid even when a CMD\_ALM has occurred.

##### (a) SVCMD\_IO (Output) Field

Bit 7	Bit 6	Bit 5	Bit 4	Bit 3	Bit 2	Bit 1	Bit 0
N_CL	P_CL	P_PPI	V_PPI	Reserved (0)			
bit 15	Bit 14	Bit 13	Bit 12	Bit 11	Bit 10	Bit 9	Bit 8
Reserved (0)				G-SEL			
Bit 23	Bit 22	Bit 21	Bit 20	Bit 19	Bit 18	Bit 17	Bit 16
SO4 or SLO4 <i>*1</i>	SO3 or SLO3 <i>*1</i>	SO2 or SLO2 <i>*1</i>	SO1 or SLO1 <i>*1</i>	BANK_SEL			
Bit 31	Bit 30	Bit 29	Bit 28	Bit 27	Bit 26	Bit 25	Bit 24
EXT_TRC	FOUT_STOP <i>*2</i>	Reserved (0)					SO5 <i>*1</i>

\*1 Valid only for Σ-X SERVOPACKs.  
Valid only for Σ-7W/Σ-XW/Σ-XT SERVOPACKs.  
If you are using a Σ-X SERVOPACK and Pn55C is set to n.□□□1 (enable the function to specify the output status when a host communications error occurs), SO1 to SO5 will change between ON and OFF according the settings of Pn55D (Specify Output Status When a Host Communications Error Occurs) in addition to the actual status of the signals.

\*2 Valid only for Σ-X SERVOPACKs.  
Valid for Σ-7S SERVOPACKs with FT/EX specifications (model: SGD7S-□□□□□□□□F62), but there are differences in the details of the function. Refer to the following manual instead of this manual if you use a Σ-7 SERVOPACK.

📖 Σ-7S SERVOPACK with FT/EX Specification for Transfer and Alignment Application Product Manual (Manual No.: SIEP S800001 95)

##### (b) Details of Output Signal Bits

The following table shows the details of the output signal bits.

Bit	Name	Description	Value	Setting	Enabled Timing
4	V_PPI	Speed Loop P/PI Control	0	PI control	Level
			1	P control	
Switches the speed control from PI control to P control. Used for adjusting the settling time by suppressing overshoot during acceleration.					
5	P_PPI	Position Loop P/PI Control	0	PI control	Level
			1	P control	
Switches the position control automatically from PI control to P control. Used for shortening the settling time by suppressing overshoot during positioning movement.					
6	P_CL	Forward Torque Limit	0	Torque not clamped	Level
			1	Torque clamped	
Used to select whether the forward torque is clamped or not according to the forward torque limit (common parameter: 8C).					
7	N_CL	Reverse Torque Limit	0	Torque not clamped	Level
			1	Torque clamped	
Used to select whether the reverse torque is clamped or not according to the reverse torque limit (common parameter: 8D).					
8 to 11	G_SEL	Gain Select	0	Gain settings 1	Level
			1	Gain settings 2	
			2	Gain settings 3: $\Sigma$ -X-series only	
			3	Gain settings 4: $\Sigma$ -X-series only	
			2 to 15	Reserved (Do not set.): For $\Sigma$ -7-series	
			4 to 15	Reserved (Do not set.): For $\Sigma$ -X-series	
Used to select the position loop gain, speed loop gain and other settings as desired according to the G_SEL value. 0:Gain settings 1 1:Gain settings 2 2:Gain settings 3: $\Sigma$ -X-series only 3:Gain settings 4: $\Sigma$ -X-series only 2 to 15: Reserved (Do not set.): For $\Sigma$ -7-series 4 to 15: Reserved (Do not set.): For $\Sigma$ -X-series					
16 to 19	BANK_SEL	Bank Selector	0	Bank 0	Level
			1	Bank 1	
			:	:	
			F	Bank F	
High-speed acceleration/deceleration parameter (bank switching) function					

Continued on next page.

Bit	Name	Description	Value	Setting	Enabled Timing
20 to 24	SO1 to SO5 or SLO1 to SLO4	I/O Signal Output Command	0	Signal OFF	Level
			1	Signal ON	
<p>Turns ON/OFF the signal output for I/O signal outputs (SO1 to SO5 or SLO1 to SLO4).                      SO1 to SO5 are used to output signals to CN1 on the SERVOPACK.                      SLO1 to SLO4 are used to output signals to connected devices when the <math>\Sigma</math>-LINK II function is used.                      To use SO1 to SO5 and SLO1 to SLO4, you must set the SERVOPACK parameters.</p> <ul style="list-style-type: none"> <li>• SO1 to SO4: Pn56A</li> <li>• SO5: Pn56B</li> <li>• SLO1 to SLO4 : Pn56A, Pn090 to Pn096, Pn0B5</li> </ul> <p>For details on the settings, refer to the product manual for your SERVOPACK.</p> <p>[Important]</p> <ul style="list-style-type: none"> <li>• <math>\Sigma</math>-7 SERVOPACKs:                      The operation of these settings is disabled when output signals are allocated to pin numbers by SERVOPACK parameters. To use these settings, disable the signal allocations by SERVOPACK parameters. The SERVOPACK parameters to set are:                     <ul style="list-style-type: none"> <li>– <math>\Sigma</math>-7S SERVOPACKs: Pn50E, Pn50F, Pn510</li> <li>– <math>\Sigma</math>-7W SERVOPACKs: Pn50E, Pn50F, Pn510, Pn5B0 to Pn5BC</li> </ul> </li> <li>• <math>\Sigma</math>-X SERVOPACKs:                      To use these settings, disable the signal allocations by SERVOPACK parameters. The SERVOPACK parameters to set are:                     <ul style="list-style-type: none"> <li>– Pn50E, Pn50F, Pn510, Pn5B0 to Pn5BC</li> </ul> </li> </ul> <p>If you do not change the SERVOPACK parameter settings, the signal output will be turned ON and OFF by an OR circuit of the signal and this setting.</p> <ul style="list-style-type: none"> <li>• <math>\Sigma</math>-7F integrated servomotor (Model: SGF7□-□□□□□□□□2□):                      This setting is disabled because it does not support I/O signal outputs (SO1 to SO3).</li> </ul>					
30	FOUT_STOP	Request to stop outputting triggers at preset positions	0	None	Leading edge
			1	Request stopping outputs at preset positions.	
<p>This bit is used to request that the triggers at preset position outputs be stopped.</p>					
31	EXT_TRC	External Trace Input	0	External trace input OFF	Level
			1	External trace input ON	
<p>Used in combination with SigmaWin+ data trace control.                      By using this bit as a trigger for data trace, data can be acquired at the preferred timing.                      Cannot be used with the motion analyze function of MPE720 at the same time.                      If you are using <math>\Sigma</math>-7-series SERVOPACKs, this bit can be used on SERVOPACKs with software version 002C or higher.</p>					

## (2) Bit Allocation of Servo Command I/O Signal Monitoring

Byte 8 to 11 of the response area of the servo command are defined as the SVCMD\_IO field.

Note that the commands in this field are valid even when a CMD\_ALM has occurred.

### (a) SVCMD\_IO (I/O Signal) Field

Bit 7	Bit 6	Bit 5	Bit 4	Bit 3	Bit 2	Bit 1	Bit 0
ESTP	EXT3	EXT2	EXT1	N-OT	P-OT	DEC	Reserved (0)
Bit 15	Bit 14	Bit 13	Bit 12	Bit 11	Bit 10	Bit 9	Bit 8
ZPOINT	PSET	NEAR	DEN	N-SOT	P-SOT	BRK_ON	Reserved (0)
Bit 23	Bit 22	Bit 21	Bit 20	Bit 19	Bit 18	Bit 17	Bit 16
Reserved (0)				ZSPD	V_CMP	V_LIM	T_LIM

Bit 31	Bit 30	Bit 29	Bit 28	Bit 27	Bit 26	Bit 25	Bit 24
IO_STS8	IO_STS7	IO_STS6	IO_STS5	IO_STS4	IO_STS3	IO_STS2	IO_STS1

### (b) Details of I/O Signal Bits

The following table shows the details of the I/O signal bits.

Bit	Name	Description	Value	Setting
1	DEC	Zero return deceleration limit switch input	0	OFF
			1	ON
The status used to judge the state of the deceleration limit switch used for zero point return operation				
2	P-OT	Forward drive prohibition input	0	OFF
			1	ON
Overtravel (OT) is a function that forcibly stops a movable machine unit if it moves beyond its range of movement. P_OT is the status used to judge if the movable machine unit is in the forward drive prohibited state. The OT stop judgment is made based on SVCMD_IO.ZSPD.				
3	N-OT	Reverse drive prohibition input	0	OFF
			1	ON
Overtravel (OT) is a function that forcibly stops a movable machine unit if it moves beyond its range of movement. N_OT is the status used to judge if the movable machine unit is in the reverse drive prohibited state. The OT stop judgment is made based on SVCMD_IO.ZSPD.				
4	EXT1	External latch 1 input	0	OFF
			1	ON
The status used to judge the state of the external latch 1 input signal [Important] The $\Sigma$ -7F integrated servomotor (Model: SGF7□-□□□□□□□□2□) does not support monitoring because it lacks external input signal 1. The value will be undefined.				
5	EXT2	External latch 2 input	0	OFF
			1	ON
The status used to judge the state of the external latch 2 input signal [Important] The $\Sigma$ -7F integrated servomotor (Model: SGF7□-□□□□□□□□2□) does not support monitoring because it lacks external input signal 2. The value will be undefined.				
6	EXT3	External latch 3 input	0	OFF
			1	ON
The status used to judge the state of the external latch 3 input signal [Important] The $\Sigma$ -7F integrated servomotor (Model: SGF7□-□□□□□□□□2□) does not support monitoring because it lacks external input signal 3. The value will be undefined.				
7	ESTP (HWBB)	Emergency stop	0	OFF
			1	ON
When the HWBB1 or HWBB2 signal is input, the power supply to the motor is shut OFF forcibly and the motor stops according to the setting of Pn001 = n.□□X.				
9	BRK_ON	Brake application output	0	Brake released
			1	Brake applied
The holding brake is used in applications where the servo driver controls the vertical axis. This is the status used to judge the state of the holding brake control signal (/BK). Note that the logic is the inverse of that of the hardware output (/BK).				

Continued on next page.

Bit	Name	Description	Value	Setting
10	P_SOT	Forward software limit	0	Range of motion
			1	Drive prohibited due to forward software limit
	The software limit forcibly stops a movable machine unit if it moves beyond the software limit range in the same manner as the overtravel function, with or without using P-OT and N-OT (overtravel signals). This is the status used to judge if the movable machine unit is in the Forward Software Limit state (common parameter: 26).			
11	N_SOT	Reverse software limit	0	Range of motion
			1	Drive prohibited due to reverse software limit
	The software limit forcibly stops a movable machine unit if it moves beyond the software limit range in the same manner as the overtravel function, with or without using P-OT and N-OT (overtravel signals). This is the status used to judge if the movable machine unit is in the Reverse Software Limit state (common parameter: 28).			
12	DEN	Distribution completed (position control mode)	0	During distribution
			1	Distribution completed
	The status used to judge if the position reference from the servo drive has been completed. This bit is valid only in position control mode.			
13	NEAR	Near position (position control mode)	0	Outside the near-position range
			1	Within the near-position range
	The status used to judge if the current position is within the range of the NEAR Signal Width (common parameter: 67) This bit is valid only in position control mode.			
14	PSET	Positioning completion (position control mode)	0	Outside the positioning completion range
			1	Within the positioning completion range
	The status used to judge if the current position is within the range of the Positioning Completed Width (common parameter: 66) This bit is valid only in position control mode. Refer to the following chapter for details.  <a href="#">5.9 Notes When the Positioning Completed State (PSET = 1) Is Established While Canceling a Motion Command on page 151</a>			
15	ZPOINT	Zero point	0	Outside the zero point position range
			1	Within the zero point position range
	The status used to judge if the current position is within the range of the Origin Detection Range (common parameter: 8B).			
16	T_LIM	Torque limit	0	Not in the torque limited state
			1	In the torque limited state
	The status used to judge if the torque is clamped at the Forward Toque Limit or the Reverse Toque (force) Limit			
17	V_LIM	Speed limit (torque control mode)	0	Speed limit not detected
			1	Speed limit detected
	The status used to judge if the speed is clamped at the limit value specified in the command or parameter This bit is valid only in the torque control mode.			
18	V_CMP	Speed match (speed control mode)	0	Speed not matched
			1	Speed Match
	The status used to judge if the speed is within the Speed Match Signal Detection Range (common parameter: 8F). This bit is valid only in the speed control mode.			

Continued from previous page.

Bit	Name	Description	Value	Setting
19	ZSPD	Zero speed	0	Zero speed not detected
			1	Zero speed detected
	The status used to judge if the current speed is within the Zero Speed Detection Range (common parameter: 8E).			
24 to 31	IO_STS1 to IO_STS8	I/O signal monitor	0	Signal OFF
			1	Signal ON
	<p>The status used to indicate the I/O signal state of CN1 You can select which I/O signal statuses to monitor by setting the SERVOPACK parameters. The parameters to set depend on your SERVOPACK as shown below.</p> <ul style="list-style-type: none"> <li>• <math>\Sigma</math>-7/<math>\Sigma</math>-XS: Pn860 to Pn863, Pn868, and Pn869</li> <li>• <math>\Sigma</math>-XW: Pn860 to Pn865, Pn868 to Pn86A</li> <li>• <math>\Sigma</math>-XT: Pn860 to Pn867, Pn868 to Pn86A</li> </ul> <p>[Important]</p> <p>The <math>\Sigma</math>-7F integrated servomotor (Model: SGF7□-□□□□□□□□2□) does not support I/O Signal Monitor (IO_STS1 to IO_STS8) because it lacks I/O signals. The value will be undefined.</p>			

## 2.6 Command Data

This section describes the servo-specific data used with servo commands.

### 2.6.1 Data Order

Data in commands and responses is stored in little endian byte order.

For example, 4-byte data "0x1234ABCD" in hexadecimal is stored from the least significant byte as shown below.

Byte	Data
1	CD
2	AB
3	34
4	12

### 2.6.2 Specifying Units

The units for the user command and parameter data can be selected.

The system of units is set in the common parameters. For the details on the common parameters, refer to the following chapter for details.

 [8 Common Parameters on page 187](#)

#### (1) Speed

The following units can be selected.

Settings are made with common parameters 41 and 42.

Unit	Remarks
Reference unit/s (default)	$\times 10^n$ [reference unit/s] can be set.
Reference unit/min	$\times 10^n$ [reference unit/min] can be set.
"%" of rated speed	$\times 10N^n$ [%] can be set.
$\text{min}^{-1}$ (rpm)	$\times 10^n$ [ $\text{min}^{-1}$ ] can be set.
Max. motor speed/40000000 (h)	Set "0" for common parameter 42.

#### (2) Position

The following units can be selected.

Settings are made with common parameters 43 and 44.

Unit	Remarks
Reference unit (default)	[Reference unit] Fixed Set "0" for common parameter 44.

#### (3) Acceleration

The following units can be selected.

Settings are made with common parameters 45 and 46.

Unit	Remarks
Reference unit/s <sup>2</sup> (default)	×10 <sup>n</sup> [reference unit/s <sup>2</sup> ] can be set.

#### (4) Torque

The following units can be selected.

Settings are made with common parameters 47 and 48.

Unit	Remarks
% of rated torque (default)	×10 <sup>n</sup> [%] can be set.
Max. torque/40000000 (h)	Set "0" for common parameter 48.

### 2.6.3 Specifying Monitor Data

The MDevice station sets the selection code of the monitor data to be read from an SDevice station at monitor selection bits SEL\_MON1 to 3 in the servo command control field (SVCMD\_CTRL) and at monitor selection bits SEL\_MON4 to 6 in the subcommand control field (SUB\_CTRL). The SDevice station sets the specified monitor selection code and the monitor data in the response.

The following table lists the monitor data.

Value	Monitor Name	Description	Remarks
00h	APOS	Feedback position	Current position of the servomotor
01h	CPOS	Reference position	Reference position after acceleration/deceleration filter
02h	PERR	Position deviation	Position deviation in control loop Valid only when performing position control
03h	LPOS1	Latched position 1	Motor position 1 when latched by latch signal
04h	LPOS2	Latched position 2	Motor position 2 when latched by latch signal
05h	FSPD	Feedback speed	–
06h	CSPD	Reference speed	–
07h	TRQ	Reference torque (force)	Reference torque (force) to motor
08h	ALARM	Detailed information on the current alarm	Current alarm or warning When an alarm has occurred after the occurrence of a warning, the information on the alarm is displayed.
09h	MPOS	Reference position	Input reference position in a position control loop MPOS = APOS + PERR
0Ch	CMN1	Common monitor 1	Select the monitor data specified by common parameter 89.
0Dh	CMN2	Common monitor 2	Select the monitor data specified by common parameter 8A.
0Eh	OMN1	Option monitor 1	Selects the monitor data specified at parameter Pn824.
0Fh	OMN2	Option monitor 2	Selects the monitor data specified at parameter Pn825.

### 2.6.4 Position Data

Servo commands use 4-byte data as position data. For infinite length operation, position data beyond this limit are expressed as shown in the diagram below.

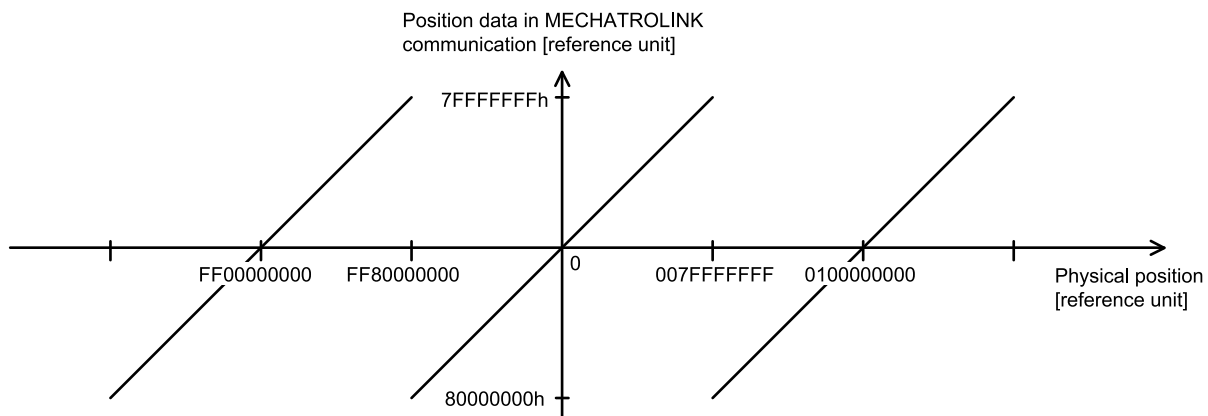

## Main Commands

---

<b>3.1</b>	<b>Common Commands</b> .....	<b>81</b>
3.1.1	No Operation Command (NOP: 00h).....	81
3.1.2	Read ID Command (ID_RD: 03h) .....	82
3.1.3	Setup Device Command (CONFIG: 04h).....	90
3.1.4	Read Alarm or Warning Command (ALM_RD: 05h) .....	92
3.1.5	Clear Alarm or Warning Command (ALM_CLR: 06h).....	93
3.1.6	Start Synchronous Communication Command (SYNC_SET: 0Dh) .....	94
3.1.7	Establish Connection Command (CONNECT: 0Eh) .....	95
3.1.8	Disconnection Command (DISCONNECT: 0Fh).....	96
3.1.9	Read Memory Subcommand (MEM_RD: 1Dh) .....	97
3.1.10	Write Memory Command (MEM_WR: 1Eh).....	98
<b>3.2</b>	<b>Servo Commands</b> .....	<b>101</b>
3.2.1	Set Coordinates Command (POS_SET: 20h) .....	101
3.2.2	Apply Brake Command (BRK_ON: 21h) .....	102
3.2.3	Release Brake Command (BRK_OFF: 22h).....	103
3.2.4	Turn Sensor ON Command (SENS_ON: 23h).....	105
3.2.5	Turn Sensor OFF Command (SENS_OFF: 24h) .....	105
3.2.6	Servo Status Monitor Command (SMON: 30h) .....	106
3.2.7	Servo ON Command (SV_ON: 31h).....	107
3.2.8	Servo OFF Command (SV_OFF: 32h) .....	108
3.2.9	Interpolation Command (INTERPOLATE: 34h) .....	109
3.2.10	Positioning Command (POSING: 35h).....	110
3.2.11	Feed Command (FEED: 36h).....	112
3.2.12	External Input Feed Command (EX_FEED: 37h) .....	114
3.2.13	External Input Positioning Command (EX_POSING: 39h).....	116
3.2.14	Zero Point Return Command (ZRET: 3Ah) .....	118
3.2.15	Velocity Control Command (VELCTRL: 3Ch).....	121
3.2.16	Torque Control Command (TRQCTRL: 3Dh).....	122
3.2.17	Read Servo Parameter Command (SVPRM_RD: 40h).....	123
3.2.18	Write Servo Parameter Command (SVPRM_WR: 41h).....	124
3.2.19	Motion Command Data Setting Method.....	125



## 3.1 Common Commands

### 3.1.1 No Operation Command (NOP: 00h)

#### (1) Data Format

Communication Phases in which the Command can be Executed		2, 3	Command Classification	Common command	Asynchronous command
Processing Time		Within communication cycle	Subcommand	Can be used	
Byte	NOP		Description		
	Command	Response			
0	00h	00h	<ul style="list-style-type: none"> <li>The NOP command is used for network control.</li> <li>The response returns the current status.</li> <li>Confirm that RCMD = NOP (= 00h) and CMD_STAT.CMDRDY = 1.</li> </ul>		
1	WDT	RWDT			
2	CMD_CTRL	CMD_STAT			
3					
4	Reserved.	Reserved.			
5					
6					
:					
29					
30					
31					

## 3.1.2 Read ID Command (ID\_RD: 03h)

### (1) Data Format

Communication Phases in which the Command can be Executed		2, 3	Command Classification	Common command	Asynchronous command
Processing Time		Within 200 ms	Subcommand	Can be used	
Byte	ID_RD		Description		
	Command	Response			
0	03h	03h	<ul style="list-style-type: none"> <li>The ID_RD command reads the ID of a device. This command reads the product information as ID data.</li> <li>The ID data is selected in detail by specifying ID_CODE.</li> <li>Confirm the completion of the command execution by checking that RCMD = ID_RD (= 03h) and CMD_STAT.CMDRDY = 1, and also checking the setting for ID_CODE, OFFSET and SIZE.</li> </ul> <p>In the following cases, an alarm will occur. Do not read ID in the response in those cases because the DATA value will be indefinite.</p> <ul style="list-style-type: none"> <li>When the ID_CODE data is invalid: CMD_ALM = 9h (A.94A)</li> <li>When the OFFSET data is invalid or the SIZE data do not match: CMD_ALM = 9h (A.94D)</li> </ul> <p>If the OFFSET or SIZE data is invalid for the specified ID_CODE, an alarm occurs.</p> <p>Example: Setting OFFSET = 3 and SIZE = 4 for reading the device version (4-byte data) specifies reading of data outside the device version data (4 bytes) and generates an alarm.</p>		
1	WDT	RWDT			
2	CMD_CTRL	CMD_STAT			
3					
4	ID_CODE	ID_CODE			
5	OFFSET	OFFSET			
6	SIZE	SIZE			
7					
8	Reserved.	ID			
9					
10					
:					
29					
30					
31					

### (2) Command Parameters

ID\_CODE: ID data selection code

OFFSET: ID read offset

SIZE: Read data size [bytes]

The following tables describe details of the ID\_CODE.

ID_CODE	Description	Data Size	Data Type
01h	Vendor ID Code	4 bytes	Binary Data
	00000000h (YASKAWA ELECTRIC CORPORATION) An ID code used to specify the vendor. Vendor ID codes are managed by the MECHATROLINK Members Association.		
02h	Device Code	4 bytes	Binary Data
	02250000h (Σ-7S SERVOPACK (SGD7S-□□□□20□))		
	02250001h (Σ-7W SERVOPACK(SGD7W-□□□□20□))		
	02250005h (Σ-7F integrated servomotor (SGF7□-□□□□□□□□2□))		
	02290000h (Σ-XS SERVOPACK (SGDXS-□□□□40□))		
	02290001h (Σ-XW SERVOPACK (SGDXW-□□□□40□))		
02290002h (Σ-XT SERVOPACK (SGDXT-□□□□40□))			
This is a code specific to each device.			
03h	Device Version	4 bytes	Binary Data
	Returns the firmware version of this product. Example: 00160000h Version information of device		

Continued on next page.

Continued from previous page.

ID_CODE	Description	Data Size	Data Type					
04h	Device Information File Version	4 bytes	Binary Data					
	This is the version information of the device information (MDI) file supported by this product.							
	Bit 7	Bit 6	Bit 5	Bit 4	Bit 3	Bit 2	Bit 1	Bit 0
	Revision No.							
	bit 15	Bit 14	Bit 13	Bit 12	Bit 11	Bit 10	Bit 9	Bit 8
	Major version				Minor version			
	Major version: When there are major changes to the MDI associated with function additions and function changes, such as addition of profiles. Minor version: When there are changes to the MDI associated with minor function additions or function changes. Revision No.: Normally returns "0." Bit 16 to 31: Reserved (0)							
05h	Extended Address Settings	4 bytes	Binary Data					
	This is the number of extended addresses used. • $\Sigma$ -7S, $\Sigma$ -XS: 1 • $\Sigma$ -7W, $\Sigma$ -XW: 2 • $\Sigma$ -XT: 3							
06h	Serial No.	32 bytes	ASCII Code (Delimiter: 00)					
	Serial number specific to each device							
10h	Profile Type 1 (Primary)	4 bytes	Binary Data					
	Profile type (primary) that the device supports 00000010h (MECHATROLINK-III standard servo profile)							
11h	Profile Version 1 (Primary)	4 bytes	Binary Data					
	Profile version (primary) that the device supports. Example: 00000030h							
12h	Profile Type 2	4 bytes	Binary Data					
	When the device supports two or more profiles, this is the (second) profile type that is supported. 000000FFh (Profile type 2 not supported)							
13h	Profile Version 2	4 bytes	Binary Data					
	When the device supports two or more profiles, this is the version of profile type 2 that is supported. Example: 00000000h (Profile type 2 not supported)							
14h	Profile Type 3	4 bytes	Binary Data					
	When the device supports two or more profiles, this is the (third) profile type that is supported. "000000FFh (unsupported code)" will be displayed because this product does not support profile type 3.							
15h	Profile Version 3	4 bytes	Binary Data					
	When the device supports two or more profiles, this is the version of profile type 3 that is supported. "00000000h" will be displayed because this product does not support profile type 3.							
16h	Minimum Value of Transmission Cycle	4 bytes	Binary Data					
	• $\Sigma$ -X/ $\Sigma$ -7S SERVOPACKs: 12500 [unit: 0.01 $\mu$ s] (= 125 $\mu$ s) • $\Sigma$ -7W SERVOPACKs: 25000 [unit: 0.01 $\mu$ s] (= 250 $\mu$ s) The minimum transmission cycle that the device can support in the granularity level of the transmission cycle increment (18h)							
17h	Maximum Value of Transmission Cycle	4 bytes	Binary Data					
	400000 [0.01 $\mu$ s unit] (4 ms) The maximum transmission cycle that the device can support in the granularity level of the transmission cycle increment (18h)							

Continued on next page.

ID_CODE	Description	Data Size	Data Type					
18h	Transmission Cycle Increment (Granularity)	4 bytes	Binary Data					
	00000003h There are the following four levels of transmission cycle increment that the device supports. This product supports level 03h. 00h: 31.25, 62.5, 125, 250, 500 (μs), 2 to 64 (ms) (2 ms increment) 01h: 31.25, 62.5, 125, 250, 500 (μs), 1 to 64 (ms) (1 ms increment) 02h: 31.25, 62.5, 125, 250, 500 (μs), 1 to 64 (ms) (0.5 ms increment) 03h: 31.25, 62.5, 125, 250, 500, 750 (μs), 1 to 64 (ms) (0.5 ms increment)							
19h	Minimum Value of Communication Cycle	4 bytes	Binary Data					
	12500 [0.01 μs unit] (0.125 ms) The minimum communications cycle that the device supports							
1Ah	Maximum Value of Communication Cycle	4 bytes	Binary Data					
	3200000 [0.01 μs unit] (32 ms) The maximum communications cycle that the device supports							
1Bh	Number of Transmission Bytes	4 bytes	Binary Data					
	0000000Eh The number of transmission bytes that the device supports The numbers of bytes to be transmitted are allocated to the following bits. (Supported:1, Not supported:0)							
	Bit 7	Bit 6	Bit 5	Bit 4	Bit 3	Bit 2	Bit 1	Bit 0
	Reserved.	Reserved.	Reserved.	64 bytes	48 bytes	32 bytes	16 bytes	8 bytes
	0	0	0	0	1	1	0	0
Bit 5 to 63: Reserved (0)								
1Ch	Number of Transmission Bytes (Current Setting)	4 bytes	Binary Data					
	0000000xh The number of transmission bytes that is currently set with DIP switch (S3). One of the bits indicated by "-" will be set to "1." The numbers of bytes to be transmitted are allocated to the following bits.							
	Bit 7	Bit 6	Bit 5	Bit 4	Bit 3	Bit 2	Bit 1	Bit 0
	Reserved.	Reserved.	Reserved.	64 bytes	48 bytes	32 bytes	16 bytes	8 bytes
	0	0	0	0	-	-	-	0
Bit 5 to 63: Reserved (0)								
1Dh	Profile Type (Current Selection)	4 bytes	Binary Data					
	This is the profile selected with the CONNECT command.							
20h	Supported Communication Mode	4 bytes	Binary Data					
	00000007h The communication mode that the device supports 0: Not supported, 1: Supported							
	Bit 7	Bit 6	Bit 5	Bit 4	Bit 3	Bit 2	Bit 1	Bit 0
	Reserved.	Reserved.	Reserved.	Reserved.	Ethernet communications	Message communications	Cyclic communications	Event-driven communications
	0	0	0	0	0	1	1	1
Bit 8 to 31: Reserved (0)								
21h	MAC Address	8 bytes	Binary Data					
	Not supported							

Continued from previous page.

ID_CODE	Description	Data Size	Data Type					
30h	List of Supported Main Commands	32 bytes	Array					
	The list of the main commands that the device supports The commands are allocated as shown below. 0: Command not supported, 1: Command supported							
	Bit 7	Bit 6	Bit 5	Bit 4	Bit 3	Bit 2	Bit 1	Bit 0
	Reserved.	ALM_CLR	ALM_RD	CONFIG	ID_RD	PRM_WR	PRM_RD	NOP
	0	1	1	1	1	0	0	1
	bit 15	Bit 14	Bit 13	Bit 12	Bit 11	Bit 10	Bit 9	Bit 8
	DISCON- NECT	CONNECT	SYNC_SET	Reserved.	Reserved.	Reserved.	Reserved.	Reserved.
	1	1	1	0	0	0	0	0
	Bit 16 to 23: Reserved (0)							
	Bit 31	Bit 30	Bit 29	Bit 28	Bit 27	Bit 26	Bit 25	Bit 24
	Reserved.	MEM_WR	MEM_RD	PPRM_WR	PPRM_RD	Reserved.	Reserved.	Reserved.
	0	1	1	0	0	0	0	0
	bit 39	Bit 38	Bit 37	Bit 36	Bit 35	Bit 34	Bit 33	Bit 32
	Reserved.	Reserved.	Reserved.	SENS_OFF	SENS_ON	BRK_OFF	BRK_ON	POS_SET
	0	0	0	1	1	1	1	1
	Bit 40 to 47: Reserved (0)							
	Bit 55	Bit 54	Bit 53	Bit 52	Bit 51	Bit 50	Bit 49	Bit 48
	EX_FEED	FEED	POSING	INTERPO- LATE	Reserved.	SV_OFF	SV_ON	SMON
	1	1	1	1	0	1	1	1
	bit 63	Bit 62	Bit 61	Bit 60	Bit 59	Bit 58	Bit 57	Bit 56
Reserved.	Reserved.	TRQCTRL	VELCTRL	Reserved.	ZRET	EX_POSING	Reserved.	
0	0	1	1	0	1	1	0	
bit 71	Bit 70	Bit 69	Bit 68	Bit 67	Bit 66	Bit 65	Bit 64	
Reserved.	Reserved.	Reserved.	Reserved.	Reserved.	Reserved.	SVPRM_WR	SVPRM_RD	
0	0	0	0	0	0	1	1	
Bit 72 to 255: Reserved (0)								

Continued on next page.

ID_CODE	Description	Data Size	Data Type					
38h	List of Supported Subcommands	32 bytes	Array					
	The list of the subcommands that the device supports The commands are allocated as shown below. 0: Command not supported, 1: Command supported							
	Bit 7	Bit 6	Bit 5	Bit 4	Bit 3	Bit 2	Bit 1	Bit 0
	Reserved.	ALM_CLR	ALM_RD	Reserved.	Reserved.	PRM_WR	PRM_RD	NOP
	0	1	1	0	0	0	0	1
	Bit 8 to 23: Reserved (0)							
	Bit 31	Bit 30	Bit 29	Bit 28	Bit 27	Bit 26	Bit 25	Bit 24
	Reserved.	MEM_WR	MEM_RD	PPRM_WR	PPRM_RD	Reserved.	Reserved.	Reserved.
	0	1	1	0	0	0	0	0
	Bit 32 to 47: Reserved (0)							
	Bit 55	Bit 54	Bit 53	Bit 52	Bit 51	Bit 50	Bit 49	Bit 48
	Reserved.	Reserved.	Reserved.	Reserved.	Reserved.	Reserved.	Reserved.	SMON
	0	0	0	0	0	0	0	1
	Bit 56 to 63: Reserved (0)							
	Bit 71	Bit 70	Bit 69	Bit 68	Bit 67	Bit 66	Bit 65	Bit 64
	Reserved.	Reserved.	Reserved.	Reserved.	Reserved.	Reserved.	SVPRM_WR	SVPRM_RD
0	0	0	0	0	0	1	1	
Bit 72 to 255: Reserved (0)								
40h	List of Supported Common Parameters	32 bytes	Array					
	The list of the common parameter numbers that the device supports The common parameters are allocated as shown below. 0: Common parameter not supported, 1: Common parameter supported							
	Bit 7	Bit 6	Bit 5	Bit 4	Bit 3	Bit 2	Bit 1	Bit 0
	07	06	05	04	03	02	01	Reserved.
	1	1	1	1	1	1	1	0
	bit 15	Bit 14	Bit 13	Bit 12	Bit 11	Bit 10	Bit 9	Bit 8
	Reserved.	Reserved.	Reserved.	0C	0B	0A	09	08
	0	0	0	1	1	1	1	1
	Bit 16 to 31: Reserved (0)							
	Bit 39	Bit 38	Bit 37	Bit 36	Bit 35	Bit 34	Bit 33	Bit 32
	27	26	25	24	23	22	21	Reserved.
	1	1	1	1	1	1	1	0
	bit 47	Bit 46	Bit 45	Bit 44	Bit 43	Bit 42	Bit 41	Bit 40
	Reserved.	Reserved.	Reserved.	Reserved.	Reserved.	Reserved.	29	28
	0	0	0	0	0	0	1	1

Continued from previous page.

ID_CODE	Description			Data Size		Data Type		
40h (Continued on next page.)	Bit 48 to 63: Reserved (0)							
	Bit 71	Bit 70	Bit 69	Bit 68	Bit 67	Bit 66	Bit 65	Bit 64
	47	46	45	44	43	42	41	Reserved.
	1	1	1	1	1	1	1	0
	bit 79	Bit 78	Bit 77	Bit 76	Bit 75	Bit 74	Bit 73	Bit 72
	Reserved.	Reserved.	Reserved.	Reserved.	Reserved.	Reserved.	49	48
	0	0	0	0	0	0	1	1
	Bit 80 to 95: Reserved (0)							
	Bit 103	Bit 102	Bit 101	Bit 100	Bit 99	Bit 98	Bit 97	Bit 96
	67	66	65	64	63	62	61	Reserved.
	1	1	1	1	1	1	1	0
	Bit 104 to 127: Reserved (0)							
	Bit 135	Bit 134	Bit 133	Bit 132	Bit 131	Bit 130	Bit 129	Bit 128
	87	86	85	84	83	82	81	Reserved.
	1	1	1	1	1	1	1	0
	Bit 143	Bit 142	Bit 141	Bit 140	Bit 139	Bit 138	Bit 137	Bit 136
	8F	8E	8D	8C	8B	8A	89	88
	1	1	1	1	1	1	1	1
	bit 151	Bit 150	Bit 149	Bit 148	Bit 147	Bit 146	Bit 145	Bit 144
	Reserved.	Reserved.	Reserved.	94	93	92	91	90
	0	0	0	1	1	1	1	1
	Bit 152 to 255: Reserved (0)							

Continued on next page.

ID_CODE	Description	Data Size	Data Type
60h	List of Supported Message Communications Subfunctions	32 bytes	Array
	The list of supported subfunctions for the MECHATROLINK message function (42h) in the message communications commands. The subfunctions are allocated as shown below. 0: Subfunction not supported, 1: Subfunction supported		
	Bit 0	Reserved.	0
	bit 1	Read memory	1
	bit 2	Write memory	1
	bit 3	Read memory (non-continuous)	1
	bit 4	Write memory (non-continuous)	1
	bit 5	Reserved.	0
	bit 6	Write memory mask	0
	Bit 7	Read memory (complex type)	0
	bit 8	Write memory (complex type)	0
	Bits 9 to 16	Reserved.	0
	bit 17	Read maximum message size	1
	Bits 18 to 32	Reserved.	0
	bit 33	Abort message	0
	Bits 34 to 48	Reserved.	0
	bit 49	Request download	0
	bit 50	Download data	0
	bit 51	End download	0
	bit 52	Request upload	0
bit 53	Upload data	0	
bit 54	End upload	0	
Bits 55 to 255	Reserved.	0	
68h	Message Communications Message Relaying Support	4 bytes	Binary Data
	Message relaying command: supported Maximum number of supported relaying hops: 10 hops The support status for the message relaying command and the maximum number of supported relaying hops. bit 0: 0: Not supported, 1: Supported		
	Bit 0	Message relaying supported status	1
	Bits 1 to 15	Reserved.	0
	Bits 16 to 32	Maximum number of supported relaying hops	10
69h	Message Communications Timeout Duration	4 bytes	Binary Data
	<ul style="list-style-type: none"> <li>• Σ-X SERVOPACKs: 5 [unit: s]</li> <li>• Σ-7 SERVOPACKs: 2 [unit: s]</li> </ul> The duration of the timeout for command processing of message communications commands excluding the file access commands (subfunction codes: 31h to 36h). If the primary station does not respond to the message from the secondary station within this time, a timeout will occur and the abort message command must be sent to cancel processing.		

Continued from previous page.

ID_CODE	Description	Data Size	Data Type
6Ah	Message Communications File Access Command Timeout Duration	4 bytes	Binary Data
	<ul style="list-style-type: none"> <li>• <math>\Sigma</math>-X SERVOPACKs: 5 [unit: s]</li> <li>• <math>\Sigma</math>-7 SERVOPACKs: 2 [unit: s]</li> </ul> The duration of the timeout for command processing during file access commands (subfunction codes: 31h to 36h). If the primary station does not respond to the message from the secondary station within this time, a timeout will occur and the abort message command must be sent to cancel processing.		
80h	Main Device Name	32 bytes	ASCII Code (Delimiter: 00)
	Product model Example:SGD7S-1R6A20A The main device name (ASCII code) <Notice> To judge the device with the host device, use the device code (02h) instead of this ID_CODE.		
90h	Sub Device 1 Name	32 bytes	ASCII Code (Delimiter: 00)
	Motor model Example: SGM7J-01A7A21 The name of sub device 1 (ASCII code) For the $\Sigma$ -7F integrated servomotor (Model: SGF7□-□□□□□□□□2□), this is the same as main device name (80h).		
98h	Sub Device 1 Version	4 bytes	Binary Data
	Firmware version of the motor encoder Example: 0000001h The version number of sub device 1		
A0h	Sub Device 2 Name	32 bytes	ASCII Code (Delimiter: 00)
	External encoder model The name of sub device 2 (ASCII code)		
A8h	Sub Device 2 Version	4 bytes	Binary Data
	The software version of the external encoder Example: 0000001h The version number of sub device 2		
B0h	Sub Device 3 Name	32 bytes	ASCII Code (Delimiter: 00)
	Not supported: NULL The name of sub device 3 (ASCII code)		
B8h	Sub Device 3 Version	4 bytes	Binary Data
	Not supported: 0000000h The version number of sub device 3		
BCh to BFh	Reserved.		
C0h	Sub Device 4 Name	32 bytes	ASCII Code (Delimiter: 00)
	The safety option module model The name of sub device 4 (ASCII code)		
C8h	Sub Device 4 Version	4 bytes	Binary Data
	The software version of the safety option module Example: 00000001h The version number of sub device 4		
D0h	Sub Device 5 Name	32 bytes	ASCII Code (Delimiter: 00)
	The feedback option module model The name of sub device 5 (ASCII code)		

Continued on next page.

ID_CODE	Description	Data Size	Data Type
D8h	Sub Device 5 Version	4 bytes	Binary Data
	The software version of the feedback option module Example: 00000001h The version number of sub device 5		
E0h	Sub Device 6 Name	32 bytes	ASCII Code (Delimiter: 00)
	Reserved. The name of sub device 6 (ASCII code)		
E8h	Sub Device 6 Version	4 bytes	Binary Data
	Reserved. The version number of sub device 6		

**Note:**

The ID\_CODE values of C0h and above are the vendor-specific area.

### 3.1.3 Setup Device Command (CONFIG: 04h)

#### (1) Data Format

Communication Phases in which the Command can be Executed		2, 3	Command Classification	Common command	Asynchronous command
Processing Time		 (2) Command Parameters on page 90	Subcommand	Cannot be used	
Byte	CONFIG		Description		
	Command	Response			
0	04h	04h	<ul style="list-style-type: none"> <li>The CONFIG command sets up devices.</li> <li>Confirm the completion of the command execution by checking that RCMD = CONFIG (= 04h) and CMD_STAT.CMDRDY = 1, and also checking the setting for CONFIG_MOD.</li> <li>CMD_STAT:Indefinite until the completion of the command</li> </ul> In the following cases, an alarm will occur and the command will not be executed. <ul style="list-style-type: none"> <li>When the CONFIG_MOD data is invalid:CMD_ALM = 9h (A.94B)</li> <li>While in the servo ON state:CMD_ALM = Ah (A.95A) (In MECHATROLINK-II communications, the servo OFF state is established and the command is executed.)</li> <li>While editing using SigmaWin or digital operator: CMD_ALM = Ah (A.95A)</li> </ul>		
1	WDT	RWDT			
2	CMD_CTRL	CMD_STAT			
3					
4	CONFIG_MOD	CONFIG_MOD			
5	Reserved.	Reserved.			
6					
7					
:					
29					
30					
31					

#### (2) Command Parameters

The details of CONFIG\_MOD are described below.

CONFIG_MOD	Description	Remarks	Processing Time
0	Re-calculating and setting up the parameters	–	Within 5 s
1	Not supported	When set, CMD_ALM = 9h (A.94B)	–
2	Initializing to the factory-set parameter setting values	Turn the power OFF after completion of the process and turn it back ON.	Within 20 s

### (3) State of Each Status during CONFIG Command Execution

The following tables show the state of each status before, during and after CONFIG command processing.

#### (a) When Re-calculating and Setting up the Parameters

Status and Output Signal	Before CONFIG Processing	During CONFIG Processing	After CONFIG Processing
D_ALM	Current state	Current state	Current state
CMDRDY	1	0	1
M_RDY	Current state	Indefinite	Current state
Other Statuses	Current state	Indefinite	Current state
ALM (CN1 Output Signal)	Current state	Current state	Current state
/S-RDY (CN1 Output Signal)	Current state	OFF	Current state
Other Output Signals	Current state	Indefinite	Current state

#### (b) When Initializing to the Factory-set Parameter Settings

Status and Output Signal	Before CONFIG Processing	During CONFIG Processing	After CONFIG Processing
D_ALM	Current state	Current state	Current state
CMDRDY	1	0	1
M_RDY	Current state	0	0
Other Statuses	Current state	Indefinite	Current state
ALM (CN1 Output Signal)	Current state	Current state	Current state
/S-RDY (CN1 Output Signal)	Current state	OFF	OFF
Other Output Signals	Current state	Indefinite	Current state

### 3.1.4 Read Alarm or Warning Command (ALM\_RD: 05h)

#### (1) Data Format

Communication Phases in which the Command can be Executed		2, 3	Command Classification	Common command	Asynchronous command
Processing Time		 (2) Command Parameters on page 92	Subcommand	Cannot be used	
Byte	ALM_RD		Description		
	Command	Response			
0	05h	05h	<ul style="list-style-type: none"> <li>The ALM_RD command reads the alarm or warning state.</li> <li>The current alarm or warning state is read to ALM_DATA.</li> <li>Confirm the completion of the command execution by checking that RCMD = ALM_RD (= 05h) and CMD_STAT.CMDRDY = 1, and also checking the setting for ALM_RD_MOD.</li> <li>ALM_INDEX is not used. Its setting is ignored.</li> </ul> In the following cases, an alarm will occur. Do not read ALM_DATA in the response in these cases because the ALM_DATA value will be indefinite. <ul style="list-style-type: none"> <li>When the ALM_RD_MOD data is invalid: CMD_ALM = 9h (A.94B)</li> </ul>		
1	WDT	RWDT			
2	CMD_CTRL	CMD_STAT			
3					
4	ALM_RD_MOD	ALM_RD_MOD			
5					
6	ALM_INDEX	ALM_INDEX			
7					
8	Reserved.	ALM_DATA			
9					
10					
:					
29					
30					
31					

**Note:**

1. ALM\_DATA specifies an alarm using 2 bytes.
2. The most recent alarms come first in the history data.
3. Normal status is indicated by 0000h.

#### (2) Command Parameters

The details of ALM\_RD\_MOD are described below.

ALM_RD_MOD	Description	Processing Time
0	Current alarm or warning state Max. 10 items (byte 8 to 27) (00h is set for the remaining bytes (byte 28 to 31).)	<ul style="list-style-type: none"> <li>Σ-7 SERVOPACKs: Within communications cycle</li> <li>Σ-X SERVOPACKs: Within 200 ms</li> </ul>
1	Alarm occurrence status history (Warnings are not retained in the history.) Max. 10 items (byte 8 to 27) (00h is set for the remaining bytes (byte 28 to 31).)	<ul style="list-style-type: none"> <li>Σ-7 SERVOPACKs: Within communications cycle</li> <li>Σ-X SERVOPACKs: Within 200 ms</li> </ul>

For Σ-7/Σ-X-series SERVOPACKs, alarm codes are defined as 2-byte data with the following configuration.

	Bits 15 to 12	Bits 11 to 0
	0	Alarm Code
Example for A.94B	0h	94BH

### 3.1.5 Clear Alarm or Warning Command (ALM\_CLR: 06h)

#### (1) Data Format

Communication Phases in which the Command can be Executed		2, 3	Command Classification	Common command	Asynchronous command
Processing Time		 (2) Command Parameters on page 93	Subcommand	Cannot be used	
Byte	ALM_CLR		Description		
	Command	Response			
0	06H	06h	<ul style="list-style-type: none"> <li>The ALM_CLR subcommand clears the alarm or warning state. It changes the state of an SDevice station, but does not eliminate the cause of the alarm or warning. ALM_CLR should be used to clear the state after the cause of the alarm or warning has been eliminated.</li> <li>When a communications error (reception error) or synchronous communications error (watchdog data error) occurs during synchronous communications, synchronous communications must be recovered by using the SYNC_SET command after the ALM_CLR command has been executed.</li> <li>Confirm the completion of the command execution by checking that RCMD = ALM_CLR (= 06h) and CMD_STAT.CMDRDY = 1, and also checking the setting for ALM_CLR_MOD.</li> </ul> <p>In the following cases, an alarm will occur and the command will not be executed.</p> <ul style="list-style-type: none"> <li>When the ALM_CLR_MOD data is invalid: CMD_ALM = 9h (A.94B)</li> <li>While editing using SigmaWin or digital operator: CMD_ALM = Ah (A.95A)</li> </ul> <p>Use this command with CMD_CTRL.ALM_CLR set to "0."</p>		
1	WDT	RWDT			
2	CMD_CTRL	CMD_STAT			
3					
4	ALM_CLR_MOD	ALM_CLR_MOD			
5					
6	Reserved.	Reserved.			
7					
8					
:					
29					
30					
31					

#### (2) Command Parameters

The details of ALM\_CLR\_MOD are described below.

ALM_CLR_MOD	Description	Processing Time
0	Clearance of the current alarm or warning state	Within 200 ms
1	Clearance of the alarm history	Within 2 s

### 3.1.6 Start Synchronous Communication Command (SYNC\_SET: 0Dh)

#### (1) Data Format

Communication Phases in which the Command can be Executed		2	Command Classification	Common command	Asynchronous command
Processing Time		Communications cycle or greater, and 5 seconds or less	Subcommand	Cannot be used	
Byte	SYNC_SET		Description		
	Command	Response			
0	0DH	0Dh	<ul style="list-style-type: none"> <li>The SYNC_SET command starts synchronous communications. The system will be in the synchronous communications mode (communication phase 3) when the execution of this command is completed and watchdog data error detection starts.</li> <li>It can be used to return to synchronous communications (communication phase 3), for example, when a shift has been made to asynchronous communications (communication phase 2) as a result of a communications error. Synchronous communications is established by taking the transition of the watchdog data (WDT) during the execution of this command as the reference.</li> <li>Maintains this command at the MDevice station until processing has been completed.</li> <li>Confirm the completion of the command execution by checking that RCMD = SYNC_SET (= 0Dh) and CMD_STAT.CMDRDY = 1.</li> <li>If the system is in communication phase 2, it will establish the servo OFF state and shift to communication phase 3.</li> <li>If the system is in communication phase 3, this command will be ignored and a normal response will be returned.</li> <li>If 8 or a higher COMM_ALM has occurred, the system shifts to communication phase 2. In such a case, first remove the cause of the error, and then restart synchronous communications by sending this command.</li> </ul> <p>In the following cases, an alarm will occur and the command will not be executed.</p> <ul style="list-style-type: none"> <li>While editing using SigmaWin or digital operator: CMD_ALM = Ah (A.95A)</li> </ul>		
1	WDT	RWDT			
2	CMD_CTRL	CMD_STAT			
3					
4	Reserved.	Reserved.			
5					
6					
:					
29					
30					
31					

### 3.1.7 Establish Connection Command (CONNECT: 0Eh)

#### (1) Data Format

Communication Phases in which the Command can be Executed		1	Command Classification	Common command	Asynchronous command
Processing Time		Communications cycle or greater, and 5 seconds or less	Subcommand	Cannot be used	
Byte	CONNECT		Description		
	Command	Response			
0	0EH	0Eh	<ul style="list-style-type: none"> <li>The CONNECT command establishes a MECHATROLINK connection. When the execution of this command has been completed, the control of SDevice stations is started by means of MECHATROLINK communication.</li> <li>Confirm the completion of the command execution by checking that RCMD = CONNECT (= 0Eh) and CMD_STAT.CMDRDY = 1, and also that the settings of VER, COM_MOD, COM_TIM, and PROFILE_TYPE of the response agree with the set data.</li> </ul> <p>In the following cases, an alarm will occur and the system will remain in communication phase 1.</p> <ul style="list-style-type: none"> <li>When the VER data is invalid: CMD_ALM = 9h (A.94B)</li> <li>When the COM_TIM data is invalid: MD_ALM = 9h (A.94B)</li> <li>When the PROFILE_TYPE data is invalid: MD_ALM = 9h (A.94B)</li> <li>When the number of transmission bytes is 32 and SUBCMD = 1: CMD_ALM = 9h (A.94B)</li> <li>While editing using SigmaWin or digital operator: CMD_ALM = Ah (A.95A)</li> </ul>		
1	WDT	RWDT			
2	CMD_CTRL	CMD_STAT			
3					
4	VER	VER			
5	COM_MOD	COM_MOD			
6	COM_TIM	COM_TIM			
7	PROFILE_TYPE	PROFILE_TYPE			
8	Reserved.	Reserved.			
9					
10					
:					
29					
30					
31					

#### (2) Command Parameters

##### (a) VER:MECHATROLINK application layer version

For MECHATROLINK-III standard servo profile: VER = 30h

##### (b) COM\_MOD: Communication mode

Bit 7	Bit 6	Bit 5	Bit 4	Bit 3	Bit 2	Bit 1	Bit 0
SUBCMD	0	0	0	DTMODE		SYNCMODE	0

- SYNCMODE: Synchronization setting  
1: Performs synchronous communication.  
(Watchdog data error detection enabled. Synchronous communication commands can be used.)  
0: Performs asynchronous communication.  
(Watchdog data error detection disabled. Synchronous communication commands cannot be used.)
- DTMODE: Data transfer method  
00: Single transmission  
01: Consecutive transmission  
10: Reserved  
11: Reserved
- SUBCMD: Subcommand setting  
0: Subcommand disabled  
1: Subcommand enabled

**(c) COM\_TIM: Communications cycle setting**

Sets the number by which to multiply the transmission cycle to get the communications cycle.

<Setting Example>

If you use a communications cycle of 2 ms for a transmission cycle of 0.5 ms,

$$COM\_TIM = 2/0.5 = 4$$

The setting range is 1 to 255. The setting must meet the following conditions.

$$\text{Minimum transmission cycle [ms]} \leq \text{Transmission cycle [ms]} \times COM\_TIM \leq 32 \text{ [ms]}$$

The minimum transmission cycle of each SERVOPACK is given below.

Series	Model	Minimum Transmission Cycle
Σ-7-Series	Σ-7S	0.125 [ms] (125 μs)
	Σ-7W	0.25 [ms] (250 μs)
Σ-X-Series	Σ-XS	0.125 [ms] (125 μs)
	Σ-XW	
	Σ-XT	

**(d) PROFILE\_TYPE: Profile type setting**

Sets the profile type to be used.

$$PROFILE\_TYPE = 10h \text{ (MECHATROLINK-III standard servo profile)}$$

**3.1.8 Disconnection Command (DISCONNECT: 0Fh)**

**(1) Data Format**

Communication Phases in which the Command can be Executed		All phases	Command Classification	Common command	Asynchronous command
Processing Time		Communications cycle or greater, and 5 seconds or less	Subcommand	Cannot be used	
Byte	DISCONNECT		Description		
	Command	Response			
0	0FH	0Fh	<ul style="list-style-type: none"> <li>When releasing a connection, the MDevice station transmits the DISCONNECT command for two or more communications cycles. At this time, the SDevice station interrupts current processing and then performs the initialization required to reestablish the connection. It then waits for the connect establishment request from the MDevice station.</li> <li>The DISCONNECT command can be sent regardless of the state of the CMD_STAT.CMDRDY bit. If the DISCONNECT command is sent when the CMD_STAT.CMDRDY state bit is 0, processing is interrupted and this command is processed.</li> <li>Control with the command sending time of the MDevice station as two or more communications cycles.</li> <li>Upon receipt of this command, the following operation is performed.                             <ul style="list-style-type: none"> <li>Shifts the communication phase to phase 1.</li> <li>Establishes the servo OFF state.</li> <li>Disables reference point setting.</li> <li>Initializes the position data.</li> </ul> </li> <li>When the control power is turned OFF at the same time the DISCONNECT command is sent, the response data is indefinite.</li> </ul>		
1	Reserved.	Reserved.			
2					
3					
:					
29					
30					
31					

### 3.1.9 Read Memory Subcommand (MEM\_RD: 1Dh)

#### (1) Data Format

Communication Phases in which the Command can be Executed		2, 3	Command Classification	Common command	Asynchronous command
Processing Time		Within 200 ms	Subcommand	Cannot be used	
Byte	MEM_RD		Description		
	Command	Response			
0	1Dh	1Dh	<ul style="list-style-type: none"> <li>The MEM_RD command reads the data stored in virtual memory by specifying the initial address and the data size for reading.</li> <li>Confirm the completion of the command execution by checking that RCMD = MEM_RD (= 1Dh) and CMD_STAT.CMDRDY = 1, and also checking the setting for ADDRESS, SIZE and MODE/DATA_TYPE.</li> </ul> <p>In the following cases, an alarm will occur. Do not read DATA in the response in these cases because the DATA value will be indefinite.</p> <ul style="list-style-type: none"> <li>When the ADDRESS data is invalid: CMD_ALM = 9h (A.94A)</li> <li>When the MODE/DATA_TYPE data is invalid: CMD_ALM = 9h (A.94B)</li> <li>When the SIZE data is invalid: MD_ALM = 9h (A.94D)</li> <li>While editing using SigmaWin or digital operator: CMD_ALM = Ah (A.95A)</li> </ul> <p>Refer to the following section for details.</p> <p> (4) Method to Access Virtual Memory Areas on page 100</p>		
1	WDT	RWDT			
2	CMD_CTRL	CMD_STAT			
3					
4	Reserved.	Reserved.			
5	MODE/DATA_TYPE	MODE/DATA_TYPE			
6	SIZE	SIZE			
7					
8					
9	ADDRESS	ADDRESS			
10					
11					
12	Reserved.	DATA			
13					
14					
:					
29					
30					
31					

#### (2) Command Parameters

##### (a) MODE/DATA\_TYPE

Bit 7	Bit 6	Bit 5	Bit 4	Bit 3	Bit 2	Bit 1	Bit 0
MODE 1: Volatile memory, 2: Not supported				DATA_TYPE 1: Byte, 2: Short, 3: Long, 4: Not supported			

##### (b) SIZE

Data size for reading (of type specified by DATA\_TYPE)

##### (c) ADDRESS



Initial address for writing

##### (d) DATA

DATA: Read data

### 3.1.10 Write Memory Command (MEM\_WR: 1Eh)

#### (1) Data Format

Communication Phases in which the Command can be Executed		2, 3	Command Classification	Common command	Asynchronous command
Processing Time		 (3) Executing the Adjustment Operation on page 99	Subcommand	Cannot be used	
Byte	MEM_WR		Description		
	Command	Response			
0	1Eh	1Eh	<ul style="list-style-type: none"> <li>The MEM_WR command writes the data in virtual memory by specifying the initial address, the data size and the data for writing.</li> <li>This command provides an adjustment function equivalent to that of the MECHATROLINK-II ADJ command.</li> <li>Confirm the completion of the command execution by checking that RCMD = MEM_WR (= 1Eh) and CMD_STAT.CMDRDY = 1, and also checking the setting for MODE/DATA_TYPE and DATA.</li> </ul> <p>In the following cases, an alarm will occur and the command will not be executed.</p> <ul style="list-style-type: none"> <li>When the ADDRESS data is invalid: CMD_ALM = 9h (A.94A)</li> <li>When the MODE/DATA_TYPE data is invalid: CMD_ALM = 9h (A.94B)</li> <li>When the SIZE data is invalid: MD_ALM = 9h (A.94D)</li> <li>When the DATA data is invalid: MD_ALM = 9h (A.94B)</li> <li>When the conditions for executing the adjustment operation (3) Executing the Adjustment Operation on page 99 are not satisfied: CMD_ALM = Ah (A.95A)</li> <li>While editing using SigmaWin or digital operator: CMD_ALM = Ah (A.95A)</li> </ul> <p>Refer to the following section for details.</p> <p> (4) Method to Access Virtual Memory Areas on page 100</p>		
1	WDT	RWDT			
2	CMD_CTRL	CMD_STAT			
3					
4	Reserved.	Reserved.			
5	MODE/DATA_TYPE	MODE/DATA_TYPE			
6	SIZE	SIZE			
7					
8	ADDRESS	ADDRESS			
9					
10					
11					
12	DATA	DATA			
13					
14					
:					
29					
30					
31					

#### (2) Command Parameters

##### (a) MODE/DATA\_TYPE

Bit 7	Bit 6	Bit 5	Bit 4	Bit 3	Bit 2	Bit 1	Bit 0
MODE 1: Volatile memory, 2: Non-volatile memory (Non-volatile memory can be selected only for common parameters.)				DATA_TYPE 1: Byte, 2: Short, 3: Long, 4: Not supported			

##### (b) SIZE

Data size for reading (of type specified by DATA\_TYPE)

##### (c) ADDRESS

Initial address for writing

**(d) DATA**

Data to be written

For details, refer to the following section.

 (3) *Executing the Adjustment Operation on page 99*

**(3) Executing the Adjustment Operation**

The table below lists the adjustment operations that can be executed.

Adjustment	Request Code	Preparation before Execution	Processing Time	Execution Conditions
Normal mode	0000h	None	200 ms max.	—
Parameter initialization	1005h	None	20 s max.	Initialization impossible while the servo is ON. After execution, the power supply must be turned OFF and then ON again.
Absolute encoder reset	1008h	Required	5 s max.	When using an incremental encoder, impossible to reset the encoder while the servo is ON. After execution, the power supply must be turned OFF and then ON again.
Automatic offset adjustment of motor current detection signals	100Eh	None	5 s max.	Cannot be adjusted when the main circuit power supply is OFF, when the servo is ON, and when the servomotor is running.
Multiturn limit setting	1013h	Required	5 s max.	When using an incremental encoder, the setting is disabled unless A.CC0 (Multiturn Limit Disagreement) occurs. After execution, the power supply must be turned OFF and then ON again.

**(a) Details of Command for Adjustment**

**Information** If you are using a  $\Sigma$ -7W/ $\Sigma$ -XW/ $\Sigma$ -XT SERVOPACK, only axis A addresses are given here.

For axis B addresses, add "0010 0000h" to the addresses listed here.

For axis C addresses, add "0020 0000h" to the addresses listed here.

- Send the following data and set the request code of the adjustment to be executed.**  
 Command = MEM\_WR  
 ADDRESS = 80004000h  
 MODE/DATA\_TYPE = 12h  
 SIZE = 0001h  
 DATA = Request code of the adjustment to be executed  
 To confirm the completion of the execution, check that CMDRDY = 1. If an error occurs, carry out the operation in step 4 to abort execution.
- For adjustment that requires a preparation process in the table, send the following data.**  
 Command = MEM\_WR  
 ADDRESS = 80004002h  
 MODE/DATA\_TYPE = 12h  
 SIZE = 0001h  
 DATA = 0002h  
 To confirm the completion of the execution, check that CMDRDY = 1. If an error occurs, carry out the operation in step 4 to abort execution.
- Send the following data to execute adjustment.**  
 Command = MEM\_WR  
 ADDRESS = 80004002h  
 MODE/DATA\_TYPE = 12h

SIZE = 0001h

DATA = 0001h

To confirm the completion of the execution, check that CMDRDY = 1. If an error occurs, carry out the operation in step 4 to abort execution.

4. **Send the following data to abort the execution.**

Command = MEM\_WR

ADDRESS = 80004000h

MODE/DATA\_TYPE = 12h

SIZE = 0001h

DATA = 0000h

To confirm the completion of the execution, check that CMDRDY = 1.

**(4) Method to Access Virtual Memory Areas**

For the information on the allocation of virtual memory areas, refer to the following chapter for details.

[9 Virtual Memory Space on page 205](#)

The details of the units (DATA\_TYPE) for accessing the virtual memory areas are described below.

Area Name	Details	DATA_TYPE	SIZE *1	Accessible/ inaccessible
Vendor-specific area	Reserved.	–	–	Inaccessible
	Register area	Short, long	Number of data	Accessible
Common parameter area	Common parameters	Long	Number of data	Accessible
ID area	Reserved.	Byte, short, long	Number of data	Accessible
	ID			
Reserved.	Reserved.	–	–	Inaccessible

\*1 Set the number of data of the data type specified by DATA\_TYPE.

The details of CMD\_ALM of the MEM\_RD/MEM\_WR command are described below.

CMD_ALM	Displayed Code	Error Details
9h	A.94A	When an initial address outside the defined areas is specified
		When an address within the reserved ranges of common parameter or vendor-specific areas is specified
		When a value other than a multiple of the data size specified in DATA_TYPE is set for ADDRESS
	A.94B	When the MODE or DATA_TYPE data is invalid
	A.94D	When the initial address is within the defined areas but the specified size goes beyond those areas
When a data size beyond the specification of the command format is set for SIZE		

## 3.2 Servo Commands

### 3.2.1 Set Coordinates Command (POS\_SET: 20h)

#### (1) Data Format

Communication Phases in which the Command can be Executed		2, 3	Command Classification	Common motion command	Asynchronous command
Processing Time		Within communications cycle	Subcommand	Cannot be used	
Byte	POS_SET		Description		
	Command	Response			
0	20H	20h	<ul style="list-style-type: none"> <li>The POS_SET command sets the coordinate system for the SDevice station. Specify the type of coordinates with the monitor selection code using POS_SEL.</li> <li>This command also provides a function to set the reference point. Specifying this command after setting REFE = 1 sets the machine zero point according to the coordinate setting values and enables the stroke check (software limit) function.</li> <li>Confirm the completion of the command execution by checking that RCMD = POS_SET (= 20h) and CMD_STAT.CMDRDY = 1, and also checking the setting for POS_SEL and POS_DATA.</li> <li>In the following cases, an alarm will occur and the command will not be executed. <ul style="list-style-type: none"> <li>When the POS_SET_MOD data is invalid: CMD_ALM = 9h (A.94B)</li> </ul> </li> </ul>		
1	WDT	RWDT			
2	CMD_CTRL	CMD_STAT			
3					
4 to 7	SVCMD_CTRL	SVCMD_STAT			
8 to 11	SVCMD_IO	SVCMD_IO			
12 to 15	POS_SET_MOD	POS_SET_MOD			
16 to 19	POS_DATA	POS_DATA			
20 to 23	Reserved	MONITOR1			
24 to 27		MONITOR2			
28 to 31		MONITOR3			

#### (2) Command Parameters

##### (a) POS\_SET\_MOD: Coordinates Setting Mode

Bit 7	Bit 6	Bit 5	Bit 4	Bit 3	Bit 2	Bit 1	Bit 0
REFE	Reserved.			POS_SEL			
Bit 15	Bit 14	Bit 13	Bit 12	Bit 11	Bit 10	Bit 9	Bit 8
Reserved.							
Bit 23	Bit 22	Bit 21	Bit 20	Bit 19	Bit 18	Bit 17	Bit 16
Reserved.							
Bit 31	Bit 30	Bit 29	Bit 28	Bit 27	Bit 26	Bit 25	Bit 24
Reserved.							

- POS\_SEL: Select coordinates system  
Set "0" (APOS (feedback position of the machine coordinates system)). When POS\_SEL is set to 0, the command/machine coordinates system is set at POS\_DATA.
- REFE: Enable/Disable setting of reference point  
0: Disables setting of a reference point.  
1: Enables setting of a reference point. The coordinate reference point setting is confirmed and the ZPOINT (zero point position) and software limit become effective.
- Reserved: Set to "0".

- (b) **POS\_DATA**  
Coordinate set value
- (c) **Reserved.**  
Set to "0".

### 3.2.2 Apply Brake Command (BRK\_ON: 21h)

#### (1) Data Format

Communication Phases in which the Command can be Executed		2, 3	Command Classification	Servo standard command	Asynchronous command
Processing Time		Within communication cycle	Subcommand	Cannot be used	
Byte	BRK_ON		Description		
	Command	Response			
0	21h	21h	<ul style="list-style-type: none"> <li>• The BRK_ON command outputs a brake operation signal.</li> <li>• Confirm the completion of the command execution by checking that RCMD = BRK_ON (= 21h) and CMD_STAT.CMDRDY = 1.</li> <li>• Valid only in the servo OFF state.</li> </ul> To use this command, set Pn50F = n.X to allocate the brake output (/BK) signal. If you do not allocate the /BK signal, BRK_ON in SVCMD_IO will change, but the /BK signal will not be output.		
1	WDT	RWDT			
2 to 3	CMD_CTRL	CMD_STAT			
4 to 7	SVCMD_CTRL	SVCMD_STAT			
8 to 11	SVCMD_IO	SVCMD_IO			
12 to 15	Reserved.	CPRM_SEL_MON1			
16 to 19		CPRM_SEL_MON2			
20 to 23		MONITOR1			
24 to 27		MONITOR2			
28 to 31		MONITOR3			

### 3.2.3 Release Brake Command (BRK\_OFF: 22h)

#### (1) Data Format

Communication Phases in which the Command can be Executed		2, 3	Command Classification	Servo standard command	Asynchronous command
Processing Time		Within communication cycle	Subcommand	Cannot be used	
Byte	BRK_OFF		Description		
	Command	Response			
0	22h	22h	<ul style="list-style-type: none"> <li>The BRK_OFF command releases the brake.</li> <li>Confirm the completion of the command execution by checking that RCMD = BRK_OFF (= 22h) and CMD_STAT.CMDRDY = 1.</li> <li>This command is enabled when Pn50F = n.□X□□ is set to a value other than 0 (allocation of /BK).</li> </ul>		
1	WDT	RWDT			
2 to 3	CMD_CTRL	CMD_STAT			
4 to 7	SVCMD_CTRL	SVCMD_STAT			
8 to 11	SVCMD_IO	SVCMD_IO			
12 to 15	Reserved.	CPRM_SEL_MON1			
16 to 19		CPRM_SEL_MON2			
20 to 23		MONITOR1			
24 to 27		MONITOR2			
28 to 31		MONITOR3			

#### (a) Brake Signal Output Timing

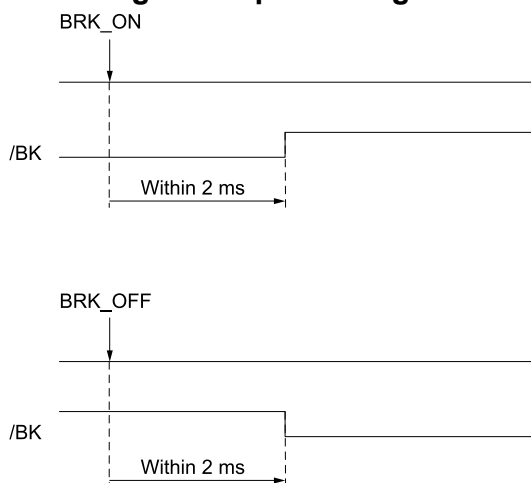

Important

Normally, brake signals are controlled by the SERVOPACK parameters.

BRK\_ON and BRK\_OFF commands are always valid as command as long as no warning occurs.

Always make sure of the status of brake control command when using BRK\_ON or BRK\_OFF command.

Sending BRK\_OFF command while the servomotor is being powered (servo ON) will not change the operation status.

However, it is very dangerous to send SV\_OFF command in the above status since the brake is kept released.

#### (b) Operation for MECHATROLINK Communications Errors

If any of the MECHATROLINK communications errors listed in the following table occurs when the brake signal is being controlled by the BRK\_OFF or BRK\_ON command, the brake signal will be output according to the setting of Pn884 = n.□□X (MECHATROLINK Communications Error Holding Brake Signal Setting). If any other alarm occurs, the status that is set for the BRK\_ON or BRK\_OFF command will be maintained regardless of the setting of Pn884 = n.□□X.

Alarm Number	Alarm Name
A.E50	MECHATROLINK Synchronization Error
A.E60	Reception Error in MECHATROLINK Communications
A.E61	Synchronization Interval Error in MECHATROLINK Transmission Cycle
A.E62	FCS Error in MECHATROLINK Communications
A.E63	MECHATROLINK Synchronization Frame Not Received

◆ **Parameter Setting**

Set the operation for a MECHATROLINK communications error using the following parameter.

Parameter	Meaning	Data Size (Byte)	
Pn884	n.□□□0 [Default setting]	Maintain the status set by the BRK_ON or BRK_OFF command when a MECHATROLINK communications error occurs.	2
	n.□□□1	Apply the holding brake when a MECHATROLINK communications error occurs.	

◆ **Brake Signal Timing Charts for MECHATROLINK Communications Error Operation Settings**

The following timing chart illustrates when Pn884 is set to n.□□□0.

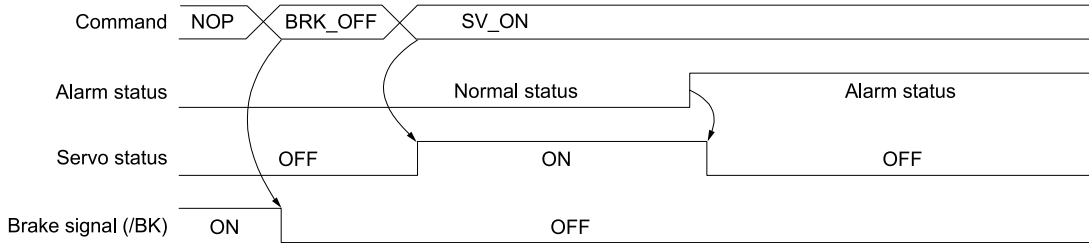

The following timing chart illustrates when Pn884 is set to n.□□□1.

• **MECHATROLINK Communications Error-Related Alarm**

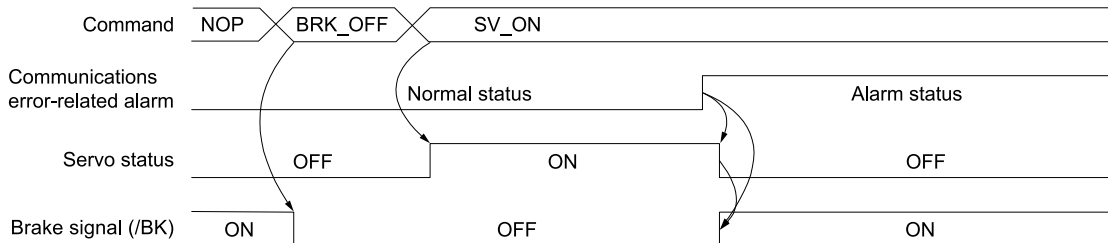

• **Alarm Other Than a MECHATROLINK Communications Error-Related Alarm**

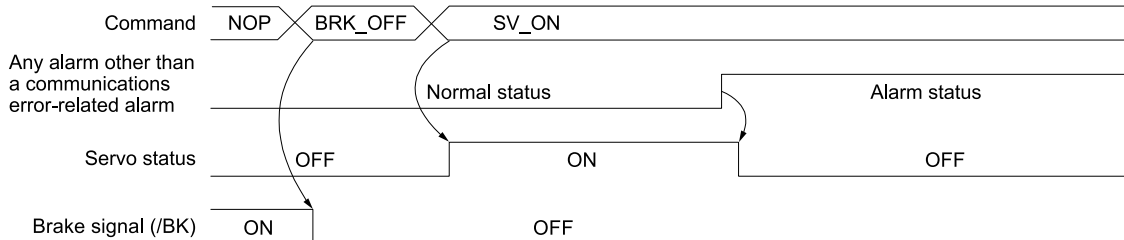

### 3.2.4 Turn Sensor ON Command (SENS\_ON: 23h)

#### (1) Data Format

Communication Phases in which the Command can be Executed		2, 3	Command Classification	Common command	Asynchronous command
Processing Time		$\Sigma$ -7 SERVO-PACKs: Within 2 s $\Sigma$ -X SERVO-PACKs: Within 10 s	Subcommand	Cannot be used	
Byte	SENS_ON		Description		
	Command	Response			
0	23h	23h	<ul style="list-style-type: none"> <li>The SENS_ON command is the sensor information initialization request command. It initializes the sensor.</li> <li>Confirm the completion of the command execution by checking that RCMD = SENS_ON (= 23h) and CMD_STAT.CMDRDY = 1.</li> <li>CPRM_SEL_MON1/CPRM_SEL_MON2: Monitor data can be selected by changing the common parameter setting. Refer to the following chapter for details. ☞ 8 Common Parameters on page 187</li> <li>When an absolute encoder is used, the initial position is acquired from the encoder. The current position is taken to be: acquired encoder position + zero point position offset (common parameter 23). The coordinate reference point setting is confirmed and the ZPOINT (zero point position) and software limit become effective.</li> <li>When an incremental encoder is used, only a response is returned without processing.</li> </ul>		
1	WDT	RWDT			
2 to 3	CMD_CTRL	CMD_STAT			
4 to 7	SVCMD_CTRL	SVCMD_STAT			
8 to 11	SVCMD_IO	SVCMD_IO			
12 to 15	Reserved	CPRM_SEL_MON1			
16 to 19		CPRM_SEL_MON2			
20 to 23		MONITOR1			
24 to 27		MONITOR2			
28 to 31		MONITOR3			

### 3.2.5 Turn Sensor OFF Command (SENS\_OFF: 24h)

#### (1) Data Format

Communication Phases in which the Command can be Executed		2, 3	Command Classification	Common command	Asynchronous command
Processing Time		Within 2 s	Subcommand	Cannot be used	
Byte	SENS_OFF		Description		
	Command	Response			
0	24h	24h	<ul style="list-style-type: none"> <li>The SENS_OFF command is the sensor power OFF request command. It is used to turn OFF the power to the sensor.</li> <li>Confirm the completion of the command execution by checking that RCMD = SENS_OFF (= 24h) and CMD_STAT.CMDRDY = 1.</li> <li>CPRM_SEL_MON1/CPRM_SEL_MON2: Monitor data can be selected by changing the common parameter setting. Refer to the following chapter for details. ☞ 8 Common Parameters on page 187</li> <li>When an absolute encoder is used, the position data is indefinite. "0" is set for POS_RDY. The coordinate reference point setting becomes invalid and the ZPOINT (zero point position) and software limit also become invalid.</li> <li>When an incremental encoder is used, only a response is returned without processing.</li> </ul> <p>In the following cases, an alarm will occur and the command will not be executed.</p> <ul style="list-style-type: none"> <li>In the servo ON state: CMD_ALM = Ah (A.95A)</li> </ul>		
1	WDT	RWDT			
2	CMD_CTRL	CMD_STAT			
3					
4 to 7	SVCMD_CTRL	SVCMD_STAT			
8 to 11	SVCMD_IO	SVCMD_IO			
12 to 15	Reserved.	CPRM_SEL_MON1			
16 to 19		CPRM_SEL_MON2			
20 to 23		MONITOR1			
24 to 27		MONITOR2			
28 to 31		MONITOR3			

### 3.2.6 Servo Status Monitor Command (SMON: 30h)

#### (1) Data Format

Communication Phases in which the Command can be Executed		2, 3	Command Classification	Servo standard command	Asynchronous command
Processing Time		Within communication cycle	Subcommand	Can be used	
Byte	SMON		Description		
	Command	Response			
0	30h	30h	<ul style="list-style-type: none"> <li>The SMON subcommand reads the alarms, status, and monitor information (position, speed, output, torque, etc.) specified in monitor setting, and the state of the I/O signals of the servo drive.</li> <li>Confirm the completion of the command execution by checking that RCMD = SMON (= 30h) and CMD_STAT.CMDRDY = 1.</li> <li>CPRM_SEL_MON1/CPRM_SEL_MON2: Monitor data can be selected by changing the common parameter setting. Refer to the following chapter for details.  <a href="#">☞ 8 Common Parameters on page 187</a></li> </ul>		
1	WDT	RWDT			
2	CMD_CTRL	CMD_STAT			
3					
4 to 7	SVCMD_CTRL	SVCMD_STAT			
8 to 11	SVCMD_IO	SVCMD_IO			
12 to 15	Reserved.	CPRM_SEL_MON1			
16 to 19		CPRM_SEL_MON2			
20 to 23		MONITOR1			
24 to 27		MONITOR2			
28 to 31		MONITOR3			

### 3.2.7 Servo ON Command (SV\_ON: 31h)

#### (1) Data Format

Communication Phases in which the Command can be Executed		2, 3	Command Classification	Servo standard command	Asynchronous command
Processing Time		Normally 50 ms (10 s max.)	Subcommand	Can be used	
Byte	SV_ON		Description		
	Command	Response			
0	31h	31h	<ul style="list-style-type: none"> <li>The SV_ON command supplies the power to the servomotor and makes it ready for operation.</li> <li>Confirm the completion of the command execution by checking that RCMD = SV_ON (= 31h) and CMD_STAT.CMDRDY = 1.</li> <li>Confirm that M_RDY = 1 before sending this command.</li> <li>CPRM_SEL_MON1/CPRM_SEL_MON2: Monitor data can be selected by changing the common parameter setting. Refer to the following chapter for details. <a href="#">☞ 8 Common Parameters on page 187</a></li> <li>To establish the servo ON state after a warning has occurred, send a command other than SV_ON, such as the SV_OFF command, and then send the SV_ON command.</li> <li>Upon completion of execution of this command, the reference position (CPOS) must be read, and the controller coordinate system must be set up.</li> </ul> <p>In the following cases, Ah (A.95A) will be set for CMD_ALM and the command will not be executed.</p> <ul style="list-style-type: none"> <li>When an alarm (COM_ALM = 8h or greater, or D_ALM = 1) has occurred</li> <li>When PON = 0</li> <li>When the execution of the SENS_ON command has not completed with an absolute encoder used</li> <li>When ESTP (HWBB signal off) = 1</li> <li>When parameters have been initialized</li> </ul>		
1	WDT	RWDT			
2	CMD_CTRL	CMD_STAT			
3					
4 to 7	SVCMD_CTRL	SVCMD_STAT			
8 to 11	SVCMD_IO	SVCMD_IO			
12 to 15	Reserved.	CPRM_SEL_MON1			
16 to 19		CPRM_SEL_MON2			
20 to 23		MONITOR1			
24 to 27		MONITOR2			
28 to 31		MONITOR3			

### 3.2.8 Servo OFF Command (SV\_OFF: 32h)

#### (1) Data Format

Communication Phases in which the Command can be Executed		2, 3	Command Classification	Servo standard command	Asynchronous command
Processing Time		Time set with Pn506 500 ms max.	Subcommand	Can be used	
Byte	SV_OFF		Description		
	Command	Response			
0	32h	32h	<ul style="list-style-type: none"> <li>The SV_OFF command shuts the power to the servomotor.</li> <li>Confirm the completion of the command execution by checking that RCMD = SV_OFF (= 32h) and CMD_STAT.CMDRDY = 1.</li> <li>CPRM_SEL_MON1/CPRM_SEL_MON2: Monitor data can be selected by changing the common parameter setting. Refer to the following chapter for details.  <a href="#">☞ 8 Common Parameters on page 187</a></li> <li>When Pn829 (SVOFF Waiting Time (for SVOFF at Deceleration to Stop) is set to a value other than "0", the servo will be turned OFF after the servomotor decelerates to a stop according to the deceleration constant for stopping set by the parameter. (The servomotor decelerates to a stop in position control mode.)</li> <li>When Pn829 (SVOFF Waiting Time (for SVOFF at Deceleration to Stop) is set to "0", the servo will be turned OFF immediately after reception of this command (default setting). (The control mode before receiving the SV_OFF command remains unchanged.)</li> <li>Executing the SV_OFF command will cancel the speed reference, speed feedforward, torque feedforward, and torque limits set by a position/speed control command.</li> </ul>		
1	WDT	RWDT			
2	CMD_CTRL	CMD_STAT			
3					
4 to 7	SVCMD_CTRL	SVCMD_STAT			
8 to 11	SVCMD_IO	SVCMD_IO			
12 to 15	Reserved.	CPRM_SEL_MON1			
16 to 19		CPRM_SEL_MON2			
20 to 23		MONITOR1			
24 to 27		MONITOR2			
28 to 31		MONITOR3			

#### (a) Related Parameters

Parameter No.	Description
Pn829	SVOFF Waiting Time (for SVOFF at Deceleration to Stop)
Pn827 (Pn840)	Linear Deceleration Constant for Stopping

**Note:**

Note: Parameter numbers in parentheses are those when Pn833 = n.□□□1 is set to 1.

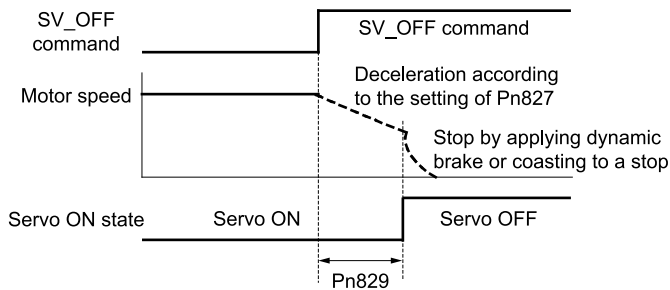

## 3.2.9 Interpolation Command (INTERPOLATE: 34h)

### (1) Data Format

Communication Phases in which the Command can be Executed		3	Command Classification	Servo standard command	Synchronous command
Processing Time		Within communications cycle	Subcommand	Can be used	
Byte	INTERPOLATE		Description		
	Command	Response			
0	34h	34h	<ul style="list-style-type: none"> <li>The INTERPOLATE command performs interpolation feeding by specifying the interpolation positions every communications cycle set in the CONNECT command.</li> <li>Confirm the completion of the command execution by checking that RCMD = INTERPOLATE (= 34h) and CMD_STAT. CMDRDY = 1.</li> <li>Confirm motion reference output completion by checking that SVCMD_IO.DEN = 1, and the completion of positioning by checking that SVCMD_IO.PSET = 1.</li> <li>CPRM_SEL_MON1/CPRM_SEL_MON2: Monitor data can be selected by changing the common parameter setting. Refer to the following chapter for details.  <a href="#">8 Common Parameters on page 187</a></li> </ul> <p>&lt;Notes on using the command&gt;</p> <ul style="list-style-type: none"> <li>TPOS (target position): Set the target position with a signed value.</li> <li>VFF (velocity feedforward): Set the speed feedforward value with a signed value. Use it as a speed feedforward function.</li> <li>TFF (torque feedforward): Set the torque feedforward value with a signed value. Use it as a torque feedforward function.</li> <li>TLIM (torque limit): Set the torque limit with an unsigned value.</li> <li>Refer to the following section for the above reference data.  <a href="#">3.2.19 Motion Command Data Setting Method on page 125</a></li> <li>Refer to the following section for the reference value units in the command area.  <a href="#">2.6.2 Specifying Units on page 76</a></li> </ul> <p>In the following cases, an alarm will occur and the command will not be executed.</p> <ul style="list-style-type: none"> <li>When used in communication phase 2: CMD_ALM = Ch (A.97A)</li> <li>In the servo OFF state: CMD_ALM = Ah (A.95A)</li> <li>When the difference relative to the previous TPOS exceeds the limit value <i>*1</i>: CMD_ALM = 9h (A.94B)</li> </ul> <p>In the following case, an alarm will occur and the relevant value will be clamped at the limit value.</p> <ul style="list-style-type: none"> <li>When the VFF data is invalid: CMD_ALM = 1h (A.97B)</li> <li>When the TFF data is invalid: CMD_ALM = 1h (A.97B)</li> </ul>		
1	WDT	RWDT			
2	CMD_CTRL	CMD_STAT			
3					
4 to 7	SVCMD_CTRL	SVCMD_STAT			
8 to 11	SVCMD_IO	SVCMD_IO			
12 to 15	TPOS	CPRM_SEL_MON1			
16 to 19	VFF	CPRM_SEL_MON2			
20 to 23	TFF	MONITOR1			
24 to 27	Reserved	MONITOR2			
28 to 31	TLIM	MONITOR3			

\*1 The limit values for the difference relative to TPOS are given below. In other words, the maximum value of the distribution amount per interpolation feeding cycle is 30 bits.

- $\Sigma$ -7 SERVOPACKs: 7D000000h [reference units/s]
- $\Sigma$ -X SERVOPACKs: 40000000h [pulses/communications cycle]

## 3.2.10 Positioning Command (POSING: 35h)

### (1) Data Format

Communication Phases in which the Command can be Executed		2, 3		Command Classification	Servo standard command	Asynchronous command
Processing Time		Within communication cycle		Subcommand	Can be used	
Byte	POSING		Description			
	Command	Response				
0	35h	35h	<ul style="list-style-type: none"> <li>The POSING command executes positioning to the specified position.</li> <li>Positioning is executed to the target position (P1) at the positioning speed.</li> <li>You can set Pn846 to a value other than 0 to use S-curve acceleration/deceleration for positioning.</li> <li>You can set Pn846 to 0 to use linear acceleration/deceleration for positioning.</li> <li>Confirm the completion of the command execution by checking that RCMD = POSING (= 35h) and CMD_STAT.CMDRDY = 1.</li> <li>Confirm the completion of motion reference output by checking that SVCMD_IO.DEN = 1, and the completion of positioning by checking that SVCMD_IO.PSET = 1.</li> <li>Confirm the completion of the cancellation of the command by checking that RCMD = POSING (= 35h), CMD_STAT.CMDRDY = 1 and SVCMD_STAT.CMD_CANCEL_CMP = 1.</li> <li>Confirm the completion of pausing of the command by checking that RCMD = POSING (= 35h), CMD_STAT.CMDRDY = 1 and SVCMD_STAT.CMD_PAUSE_CMP = 1.</li> <li>CPRM_SEL_MON1/CPRM_SEL_MON2: Monitor data can be selected by changing the common parameter setting. Refer to the following chapter for details. <ul style="list-style-type: none"> <li><a href="#">8 Common Parameters on page 187</a></li> </ul> </li> </ul> <p>&lt;Notes on using the command&gt;</p> <ul style="list-style-type: none"> <li>TPOS (target position): Set the target position with a signed value.</li> <li>TSPD (target speed): Set the target speed with an unsigned value.</li> <li>ACCR (acceleration): Set the acceleration with an unsigned value.</li> <li>DECR (deceleration): Set the deceleration with an unsigned value. When both ACCR and DECR are "0", acceleration/deceleration is performed according to the parameter settings. When acceleration/deceleration is set with parameters, it can also operate as 2-step acceleration/deceleration. Refer to the following section for details on the parameter settings. <ul style="list-style-type: none"> <li><a href="#">6.1.2 Positioning Command (POSING, FEED, EX_FEED, EX_POSING, ZRET) on page 155</a></li> </ul> </li> <li>TLIM (torque limit): Set the torque limit with an unsigned value. When not applying the torque limit, set the maximum value.</li> <li>Refer to the following section for the above reference data. <ul style="list-style-type: none"> <li><a href="#">3.2.19 Motion Command Data Setting Method on page 125</a></li> </ul> </li> <li>Refer to the following section for the reference value units in the command area. <ul style="list-style-type: none"> <li><a href="#">2.6.2 Specifying Units on page 76</a></li> </ul> </li> </ul> <p>In the following cases, an alarm will occur and the command will not be executed.</p> <ul style="list-style-type: none"> <li>In the servo OFF state: CMD_ALM = Ah (A.95A)</li> <li>When the TSPD data is invalid: CMD_ALM = 9h (A.94B)</li> <li>When the ACCR or DECR data is invalid: CMD_ALM = 9h (A.94B)</li> <li>When either of the ACCR or DECR data is set to "0": CMD_ALM = 9h (A.94B)</li> </ul> <p>In the following case, an alarm will occur and the relevant value will be clamped at the limit value.</p> <ul style="list-style-type: none"> <li>When the TLIM data is invalid: CMD_ALM = 1h (A.97B)</li> </ul>			
1	WDT	RWDT				
2	CMD_CTRL	CMD_STAT				
3						
4 to 7	SVCMD_CTRL	SVCMD_STAT				
8 to 11	SVCMD_IO	SVCMD_IO				
12 to 15	TPOS	CPRM_SEL_MON1				
16 to 19	TSPD	CPRM_SEL_MON2				
20 to 23	ACCR	MONITOR1				
24 to 27	DECR	MONITOR2				
28 to 31	TLIM	MONITOR3				

### (2) Operation for Linear Acceleration/Deceleration

The following figure shows operation for linear acceleration/deceleration.

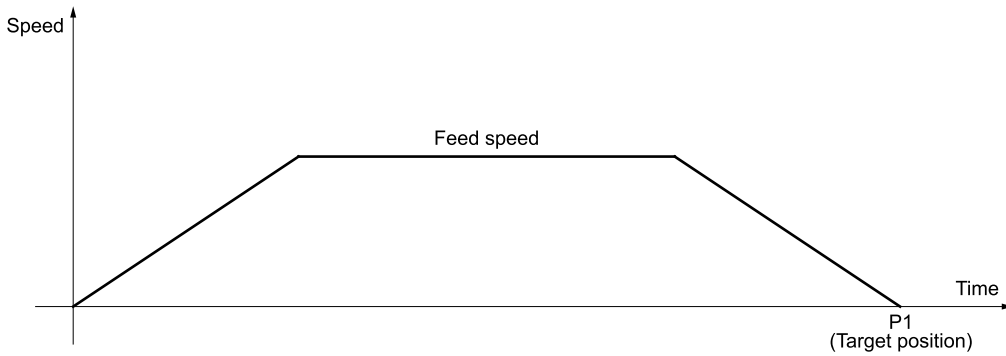

### (3) Operation for S-Curve Acceleration/Deceleration

The following figure shows operation for S-curve acceleration/deceleration.

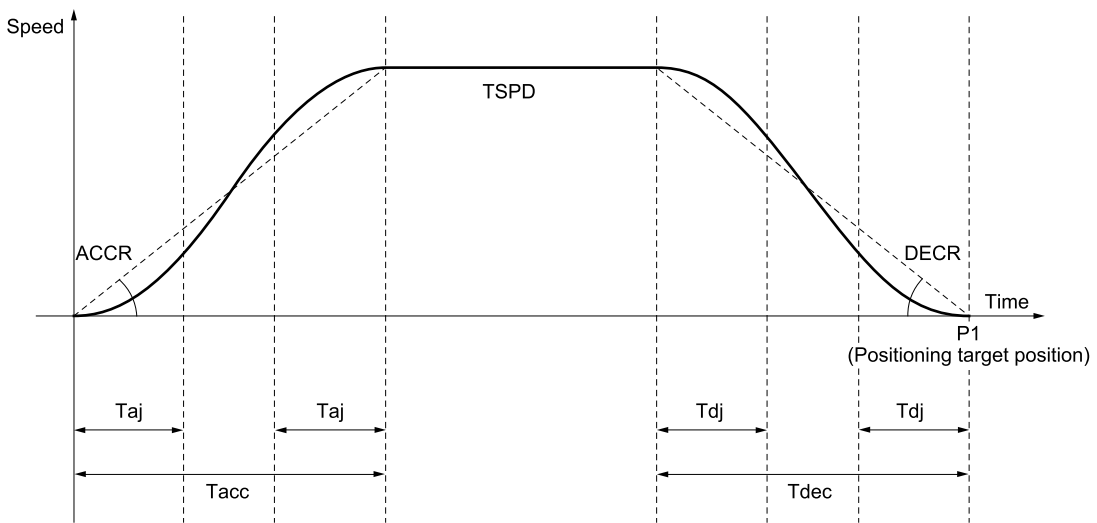

Acceleration time:  $T_{acc} = TSPD/ACCR$   
 S-curve acceleration time:  $T_{aj} = S\_RATIO \times T_{acc}$

Deceleration time:  $T_{dec} = TSPD/DECR$   
 S-curve deceleration time:  $T_{dj} = S\_RATIO \times T_{dec}$



Important

- If the value of the TPOS, TSPD, ACCR, or DECR field is changed during positioning, the change will be made when positioning is stopped or during constant-speed movement.
- If the acceleration/deceleration time is too long, linear acceleration/deceleration will be used. Linear acceleration/deceleration will be used when the rate of acceleration/deceleration (ACCR, DCCR) meets the following condition for the target speed (TSPD).  
 $Acceleration/deceleration\ rate\ [ref/s^2] < 700 \times \sqrt{(TSPD)}$
- Set the S-curve acceleration/deceleration ratio (S\_RATIO) in Pn846 (S-Curve Acceleration/Deceleration Ratio).

Parameter	Name	Data Size (Byte)	Setting Range	Setting Unit	Default Setting
Pn846	POSING Command S-curve Acceleration/Deceleration Rate	2	0 to 50	1%	0

## 3.2.11 Feed Command (FEED: 36h)

### (1) Data Format

Communication Phases in which the Command can be Executed		2, 3	Command Classification	Servo standard command	Asynchronous command
Processing Time		Within communication cycle	Subcommand	Can be used	
Byte	FEED		Description		
	Command	Response			
0	36h	36h	<ul style="list-style-type: none"> <li>The FEED command performs constant speed feed control at the specified feed speed.</li> <li>To change the speed and direction of feed, change the feed speed setting.</li> <li>To cancel constant speed feed, set SVCMD_CTRL.CMD_CANCEL to "1."</li> <li>To pause constant speed feed, set SVCMD_CTRL.CMD_PAUSE to "1."</li> <li>Confirm the completion of the cancellation of the command by checking that RCMD = FEED (= 36h), CMD_STAT.CMDRDY = 1 and SVCMD_STAT.CMD_CANCEL_CMP = 1.</li> <li>Confirm the completion of motion reference output by checking that SVCMD_IO.DEN = 1, and the completion of positioning by checking that SVCMD_IO.PSET = 1.</li> <li>Confirm the completion of pausing of the command by checking that RCMD = FEED (= 36h), CMD_STAT.CMDRDY = 1 and SVCMD_STAT.CMD_PAUSE_CMP = 1.</li> <li>CPRM_SEL_MON1/CPRM_SEL_MON2: Monitor data can be selected by changing the common parameter setting. Refer to the following chapter for details. <ul style="list-style-type: none"> <li><a href="#">8 Common Parameters on page 187</a></li> </ul> </li> </ul> <p>&lt;Notes on using the command&gt;</p> <ul style="list-style-type: none"> <li>TSPD (target speed): Set the target speed with a signed value.</li> <li>ACCR (acceleration): Set the acceleration with an unsigned value.</li> <li>DECR (deceleration): Set the deceleration with an unsigned value. When both ACCR and DECR are "0", acceleration/deceleration is performed according to the parameter settings. When acceleration/deceleration is set with parameters, it can also operate as 2-step acceleration/deceleration. Refer to the following section for details on the parameter settings. <ul style="list-style-type: none"> <li><a href="#">6.1.2 Positioning Command (POSING, FEED, EX_FEED, EX_POSING, ZRET) on page 155</a></li> </ul> </li> <li>TLIM (torque limit): Set the torque limit with an unsigned value.</li> <li>Refer to the following section for the above reference data. <ul style="list-style-type: none"> <li><a href="#">3.2.19 Motion Command Data Setting Method on page 125</a></li> </ul> </li> <li>Refer to the following section for the reference value units in the command area. <ul style="list-style-type: none"> <li><a href="#">2.6.2 Specifying Units on page 76</a></li> </ul> </li> </ul> <p>In the following cases, an alarm will occur and the command will not be executed.</p> <ul style="list-style-type: none"> <li>In the servo OFF state: CMD_ALM = Ah (A.95A)</li> <li>When the TSPD data is invalid: CMD_ALM = 9h (A.94B)</li> <li>When the ACCR or DECR data is invalid: CMD_ALM = 9h (A.94B)</li> <li>When either of the ACCR or DECR data is set to "0": CMD_ALM = 9h (A.94B)</li> </ul> <p>In the following case, an alarm will occur and the relevant value will be clamped at the limit value.</p> <ul style="list-style-type: none"> <li>When the TLIM data is invalid: CMD_ALM = 1h (A.97B)</li> </ul>		
1	WDT	RWDT			
2	CMD_CTRL	CMD_STAT			
3					
4 to 7	SVCMD_CTRL	SVCMD_STAT			
8 to 11	SVCMD_IO	SVCMD_IO			
12 to 15	Reserved.	CPRM_SEL_MON1			
16 to 19	TSPD	CPRM_SEL_MON2			
20 to 23	ACCR	MONITOR1			
24 to 27	DECR	MONITOR2			
28 to 31	TLIM	MONITOR3			

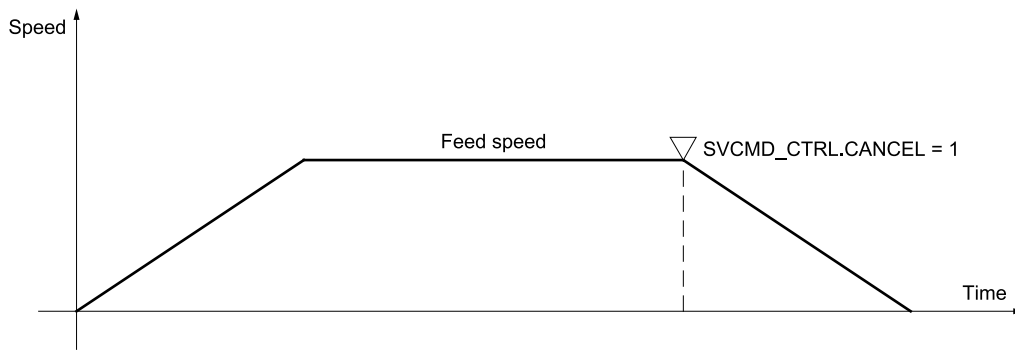

## 3.2.12 External Input Feed Command (EX\_FEED: 37h)

### (1) Data Format

Communication Phases in which the Command can be Executed		2, 3	Command Classification	Servo standard command	Asynchronous command
Processing Time		Within communication cycle	Subcommand	Can be used	
Byte	EX_FEED		Description		
	Command	Response			
0	37h	37h	<ul style="list-style-type: none"> <li>The EX_FEED command performs positioning in response to the input of the external positioning signal during constant speed feed at the specified feed speed.</li> <li>To change the speed and direction of feed, change the feed speed setting.</li> <li>To pause external input feed, set SVCMD_CTRL.CMD_PAUSE to "1."</li> <li>Confirm the completion of the command execution by checking that RCMD = EX_FEED (= 37h) and CMD_STAT.CMDRDY = 1.</li> <li>To cancel constant speed feeding, set SVCMD_CTRL.CMD_CANCEL to "1."</li> <li>Confirm the completion of latching by the latch signal by checking that SVCMD_STAT.L_CMP1 = 1.</li> <li>Confirm the completion of motion reference output by checking that SVCMD_IO.DEN = 1, and the completion of positioning by checking that SVCMD_IO.PSET = 1.</li> <li>Confirm the completion of the cancellation of the command by checking that RCMD = EX_FEED (= 37h), CMD_STAT.CMDRDY = 1 and SVCMD_STAT.CMD_CANCEL_CMP = 1.</li> <li>Confirm the completion of pausing of the command by checking that RCMD = EX_FEED (= 37h), CMD_STAT.CMDRDY = 1 and SVCMD_STAT.CMD_PAUSE_CMP = 1.</li> <li>CPRM_SEL_MON1/CPRM_SEL_MON2: Monitor data can be selected by changing the common parameter setting. Refer to the following chapter for details.  <a href="#">☞ 8 Common Parameters on page 187</a></li> </ul> <p>&lt;Notes on using the command&gt;</p> <ul style="list-style-type: none"> <li>To send this command, select the latch signal with LT_SEL1 of SVCMD_CTRL and output the latch request by setting LT_REQ1 = 1.</li> <li>TSPD (target speed): Set the target speed with a signed value.</li> <li>ACCR (acceleration): Set the acceleration with an unsigned value.</li> <li>DECR (deceleration): Set the deceleration with an unsigned value. When both ACCR and DECR are "0", acceleration/deceleration is performed according to the parameter settings. When acceleration/deceleration is set with parameters, it can also operate as 2-step acceleration/deceleration. Refer to the following section for details on the parameter settings.  <a href="#">☞ 6.1.2 Positioning Command (POSING, FEED, EX_FEED, EX_POSING, ZRET) on page 155</a></li> <li>TLIM (torque limit): Set the torque limit with an unsigned value.</li> <li>Refer to the following section for the above reference data.  <a href="#">☞ 3.2.19 Motion Command Data Setting Method on page 125</a></li> <li>Refer to the following section for the reference value units in the command area.  <a href="#">☞ 2.6.2 Specifying Units on page 76</a></li> </ul> <p>In the following cases, an alarm will occur and the command will not be executed.</p> <ul style="list-style-type: none"> <li>In the servo OFF state: CMD_ALM = Ah (A.95A)</li> <li>When the TSPD data is invalid: CMD_ALM = 9h (A.94B)</li> <li>When the ACCR or DECR data is invalid: CMD_ALM = 9h (A.94B)</li> </ul> <p>In the following case, an alarm will occur and the relevant value will be clamped at the limit value.</p> <ul style="list-style-type: none"> <li>When the TLIM data is invalid: CMD_ALM = 1h (A.97B)</li> </ul>		
1	WDT	RWDT			
2	CMD_CTRL	CMD_STAT			
3					
4 to 7	SVCMD_CTRL	SVCMD_STAT			
8 to 11	SVCMD_IO	SVCMD_IO			
12 to 15	Reserved.	CPRM_SEL_MON1			
16 to 19	TSPD	CPRM_SEL_MON2			
20 to 23	ACCR	MONITOR1			
24 to 27	DECR	MONITOR2			
28 to 31	TLIM	MONITOR3			

## (2) Operating Sequence

The following describes the operating sequence for external input positioning operation using the EX\_FEED command.

No.	Description
1	The MDevice sends the EX_FEED command. It selects the latch signal with SVCMD_CTRL.LT_SEL1 and sends SVCMD_CTRL.LT_REQ1 = 1 (latch request).
2	The SDevice station starts feeding at the specified speed (value set in the TSPD field) when it receives the EX_FEED command. At the same time, it enters the external input positioning mode.
3	When the external positioning signal is input, the SDevice station sets SVCMD_STAT.L_CMP1 to "1" (latch completed) to notify the MDevice station that current position latching by the external positioning signal is completed.
4	The SDevice station calculates "(External input positioning target P3) = (Position P2 latched by the external positioning signal) + (Travel distance for external input positioning (common parameter 83))" and performs positioning to external input positioning target P3.
5	After the completion of motion reference output to move the device to target position P3, the SDevice station sets SVCMD_IN.DEN = 1 (distribution completed) to notify the MDevice station of the completion of motion reference output to move the device to target position P3.

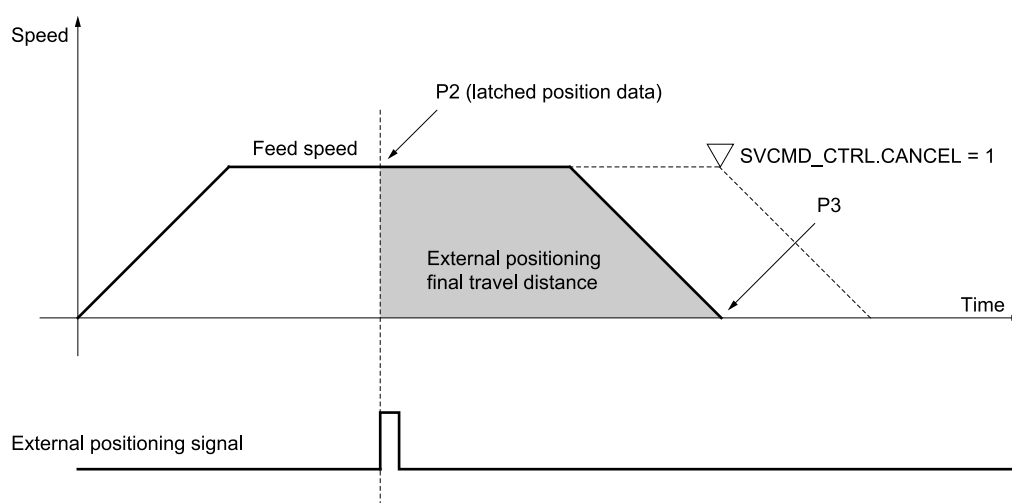

### Information

- To cancel the external input feed, set SVCMD\_CTRL.CMD\_CANCEL to "1" (cancellation of move command).
- The motion direction after latching is determined by the sign of the value set for the external positioning final travel distance.
  - If the final travel distance for external positioning is a positive value:
    - After latching during motion in the positive direction, the motor rotates in the positive direction (the same direction) for positioning.
    - After latching during motion in the negative direction, the motor rotates in the positive direction (the reverse direction) for positioning.
  - If the final travel distance for external positioning is a negative value:
    - After latching during motion in the positive direction, the motor rotates in the negative direction (the reverse direction) for positioning.
    - After latching during motion in the negative direction, the motor rotates in the negative direction (the same direction) for positioning.

### 3.2.13 External Input Positioning Command (EX\_POSING: 39h)

#### (1) Data Format

Communication Phases in which the Command can be Executed		2, 3		Command Classification	Servo standard command	Asynchronous command
Processing Time		Within communication cycle		Subcommand	Can be used	
Byte	EX_POSING		Description			
	Command	Response				
0	39h	39h	<ul style="list-style-type: none"> <li>The EX_POSING command performs positioning in response to the input of the external positioning signal.</li> <li>To pause the external input positioning, set SVCMD_CTRL.CMD_PAUSE to "1."</li> <li>Confirm the completion of the command execution by checking that RCMD = EX_POSING (= 39h) and CMD_STAT.CMDRDY = 1.</li> <li>Confirm the completion of latching by the latch signal by checking that SVCMD_STAT.L_CMP1 = 1.</li> <li>Confirm the completion of motion reference output by checking that SVCMD_IO.DEN = 1, and the completion of positioning by checking that SVCMD_IO.PSET = 1.</li> <li>Confirm the completion of the cancellation of the command by checking that RCMD = EX_POSING (= 39h), CMD_STAT.CMDRDY = 1 and SVCMD_STAT.CMD_CANCEL_CMP = 1.</li> <li>Confirm the completion of pausing of the command by checking that RCMD = EX_POSING (= 39h), CMD_STAT.CMDRDY = 1 and SVCMD_STAT.CMD_PAUSE_CMP = 1.</li> <li>CPRM_SEL_MON1/CPRM_SEL_MON2: Monitor data can be selected by changing the common parameter setting. Refer to the following chapter for details. <ul style="list-style-type: none"> <li>8 Common Parameters on page 187</li> </ul> </li> </ul> <p>&lt;Notes on using the command&gt;</p> <ul style="list-style-type: none"> <li>To send this command, select the latch signal with LT_SEL1 of SVCMD_CTRL and output the latch request by setting LT_REQ1 = 1.</li> <li>TPOS (target position): Set the target position with a signed value.</li> <li>TSPD (target speed): Set the target speed with an unsigned value.</li> <li>ACCR (acceleration): Set the acceleration with an unsigned value.</li> <li>DECR (deceleration): Set the deceleration with an unsigned value. When both ACCR and DECR are "0", acceleration/deceleration is performed according to the parameter settings. When acceleration/deceleration is set with parameters, it can also operate as 2-step acceleration/deceleration. Refer to the following section for details on the parameter settings. <ul style="list-style-type: none"> <li>6.1.2 Positioning Command (POSING, FEED, EX_FEED, EX_POSING, ZRET) on page 155</li> </ul> </li> <li>TLIM (torque limit): Set the torque limit with an unsigned value.</li> <li>Refer to the following section for the above reference data. <ul style="list-style-type: none"> <li>3.2.19 Motion Command Data Setting Method on page 125</li> </ul> </li> <li>Refer to the following section for the reference value units in the command area. <ul style="list-style-type: none"> <li>2.6.2 Specifying Units on page 76</li> </ul> </li> </ul> <p>In the following cases, an alarm will occur and the command will not be executed.</p> <ul style="list-style-type: none"> <li>In the servo OFF state: CMD_ALM = Ah (A.95A)</li> <li>When the TSPD data is invalid: CMD_ALM = 9h (A.94B)</li> <li>When the ACCR or DECR data is invalid: CMD_ALM = 9h (A.94B)</li> </ul> <p>In the following case, an alarm will occur and the relevant value will be clamped at the limit value.</p> <ul style="list-style-type: none"> <li>When the TLIM data is invalid: CMD_ALM = 1h (A.97B)</li> </ul>			
1	WDT	RWDT				
2	CMD_CTRL	CMD_STAT				
3						
4 to 7	SVCMD_CTRL	SVCMD_STAT				
8 to 11	SVCMD_IO	SVCMD_IO				
12 to 15	TPOS	CPRM_SEL_MON1				
16 to 19	TSPD	CPRM_SEL_MON2				
20 to 23	ACCR	MONITOR1				
24 to 27	DECR	MONITOR2				
28 to 31	TLIM	MONITOR3				

## (2) Operating Sequence

The following describes the operating sequence for external input positioning operation using the EX\_POSING command.

No.	Description
1	The MDevice station sends the EX_POSING command. Target position P1 is set in the "target position" field to be used as the positioning target if the external signal is not input. It selects the latch signal with SVCMD_CTRL.LT_SEL1 and sends SVCMD_CTRL.LT_REQ1 = 1 (latch request).
2	The SDevice station starts feeding toward the positioning target position P1 at the specified speed (value that was set in the TSPD field) when it receives the EX_POSING command. At the same time, it enters the external input positioning mode.
3	When the external positioning signal is input, the SDevice station sets SVCMD_STAT.L_CMP1 to "1" (latch completed) to notify the MDevice station that current position latching by the external positioning signal is completed.
4	The SDevice station calculates "(External input positioning target P3) = (Position P2 latched by the external positioning signal) + (Travel distance for external input positioning (common parameter 83))" and performs positioning to external input positioning target P3.
5	After the completion of motion reference output to move the device to target position P3, the SDevice station sets SVCMD_IN.DEN = 1 (distribution completed) to notify the MDevice station of the completion of motion reference output to move the device to target position P3.

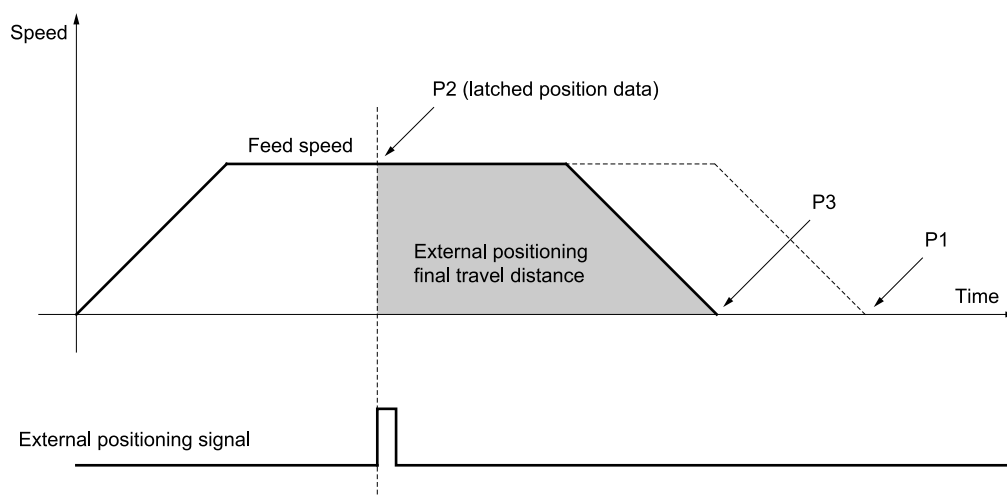

- Information**
- To cancel the external input positioning, set SVCMD\_CTRL.CMD\_CANCEL to "1" (cancellation of move command).
  - The motion direction after latching is determined by the sign of the value set for the external positioning final travel distance.
    - If the final travel distance for external positioning is a positive value:
      - After latching during motion in the positive direction, the motor rotates in the positive direction (the same direction) for positioning.
      - After latching during motion in the negative direction, the motor rotates in the positive direction (the reverse direction) for positioning.
    - If the final travel distance for external positioning is a negative value:
      - After latching during motion in the positive direction, the motor rotates in the negative direction (the reverse direction) for positioning.
      - After latching during motion in the negative direction, the motor rotates in the negative direction (the same direction) for positioning.
  - If you are using a  $\Sigma$ -X SERVOPACK, you can perform the S-curve acceleration/deceleration operation by setting Pn846 in the same manner as the POSING command. Refer to the following section for details on S-curve acceleration/deceleration.
    - ☞ (3) [Operation for S-Curve Acceleration/Deceleration on page 111](#)

## 3.2.14 Zero Point Return Command (ZRET: 3Ah)

### (1) Data Format

Communication Phases in which the Command can be Executed		2, 3		Command Classification	Servo standard command	Asynchronous command
Processing Time		Within communication cycle		Subcommand	Can be used	
Byte	ZRET		Description			
	Command	Response				
0	3Ah	3Ah	<ul style="list-style-type: none"> <li>The ZRET command specifies the type of zero point return operation and performs the operation using the zero point limit switch and the position latch signal.</li> <li>The signal used to latch the position is specified by "latch signal selection."</li> <li>To pause the zero point return operation, set SVCMD_CTRL.CMD_PAUSE to "1."</li> <li>Confirm the completion of the command execution by checking that RCMD = ZRET (= 3Ah) and CMD_STAT.CMDRDY = 1.</li> <li>Confirm the completion of motion reference output by checking that SVCMD_IO.DEN = 1, and the completion of positioning at the zero point by checking that SVCMD_IO.ZPOINT (zero point position) = 1 and SVCMD_IO.PSET = 1.</li> <li>Confirm the completion of the cancellation of the command by checking that RCMD = ZRET (= 3Ah), CMD_STAT.CMDRDY = 1 and SVCMD_STAT.CMD_CANCEL_CMP = 1.</li> <li>Confirm the completion of pausing of the command by checking that RCMD = ZRET (= 3Ah), CMD_STAT.CMDRDY = 1 and SVCMD_STAT.CMD_PAUSE_CMP = 1.</li> <li>CPRM_SEL_MON1/CPRM_SEL_MON2: Monitor data can be selected by changing the common parameter setting. Refer to the following chapter for details.  <a href="#">8 Common Parameters on page 187</a></li> </ul> <p>&lt;Notes on using the command&gt;</p> <ul style="list-style-type: none"> <li>To send this command, select the latch signal with LT_SEL1 of SVCMD_CTRL and output the latch request by setting LT_REQ1 = 1.</li> <li>TSPD (target speed): Set the target speed with an unsigned value.</li> <li>ACCR (acceleration): Set the acceleration with an unsigned value.</li> <li>DECR (deceleration): Set the deceleration with an unsigned value. When both ACCR and DECR are "0", acceleration/deceleration is performed according to the parameter settings. When acceleration/deceleration is set with parameters, it can also operate as 2-step acceleration/deceleration. Refer to the following section for details on the parameter settings.  <a href="#">6.1.2 Positioning Command (POSING, FEED, EX_FEED, EX_POSING, ZRET) on page 155</a></li> <li>TLIM (torque limit): Set the torque limit with an unsigned value.</li> <li>Refer to the following section for the above reference data.  <a href="#">3.2.19 Motion Command Data Setting Method on page 125</a></li> <li>Refer to the following section for the reference value units in the command area.  <a href="#">2.6.2 Specifying Units on page 76</a></li> </ul> <p>In the following cases, an alarm will occur and the command will not be executed.</p> <ul style="list-style-type: none"> <li>In the servo OFF state: CMD_ALM = Ah (A.95A)</li> <li>When the TSPD data is invalid: CMD_ALM = 9h (A.94B)</li> <li>When the ACCR or DECR data is invalid: CMD_ALM = 9h (A.94B)</li> </ul> <p>In the following case, an alarm will occur and the relevant value will be clamped at the limit value.</p> <ul style="list-style-type: none"> <li>When the TLIM data is invalid: CMD_ALM = 1h (A.97B)</li> </ul>			
1	WDT	RWDT				
2	CMD_CTRL	CMD_STAT				
3						
4 to 7	SVCMD_CTRL	SVCMD_STAT				
8 to 11	SVCMD_IO	SVCMD_IO				
12 to 15	MODE	CPRM_SEL_MON1				
16 to 19	TSPD	CPRM_SEL_MON2				
20 to 23	ACCR	MONITOR1				
24 to 27	DECR	MONITOR2				
28 to 31	TLIM	MONITOR3				

## (2) Command Parameters

### (a) MODE

Bit 7	Bit 6	Bit	Bit 4	Bit 3	Bit 2	Bit 1	Bit 0
HOME_DIR	Reserved.	Reserved.	Reserved.	TYPE			

- HOME\_DIR (Zero point return direction)  
Selects the zero point return direction.  
0 = Positive direction  
1 = Negative direction
- TYPE (Zero point return type)  
Sets the zero point return type on selection of the type from the patterns below.  
0 = Latch signal  
1 = Deceleration limit switch + Latch signal

## (3) Operating Sequence

The following describes the zero point return operating sequence for each of the zero point return modes.

### (a) MODE.TYPE = 0 (Latch Signal)

No.	Description
1	The MDevice station sends the ZRET command. It selects the latch signal with LT_SEL1 of SVCMD_CTRL and outputs the latch request by setting LT_REQ1 = 1.
2	The SDevice station starts feeding in the direction specified by MODE.HOME_DIR at the speed set for the Homing Approach Speed (common parameter 84).
3	When the current position latch signal, specified by LT_SEL1 of SVCMD_CTRL, is input, the SDevice station executes positioning through the movement of the Final Travel Distance for Homing (common parameter 86) at the Homing Creep Speed (common parameter 85). After the completion of positioning, the SDevice station sets the zero point of the reference coordinate system.

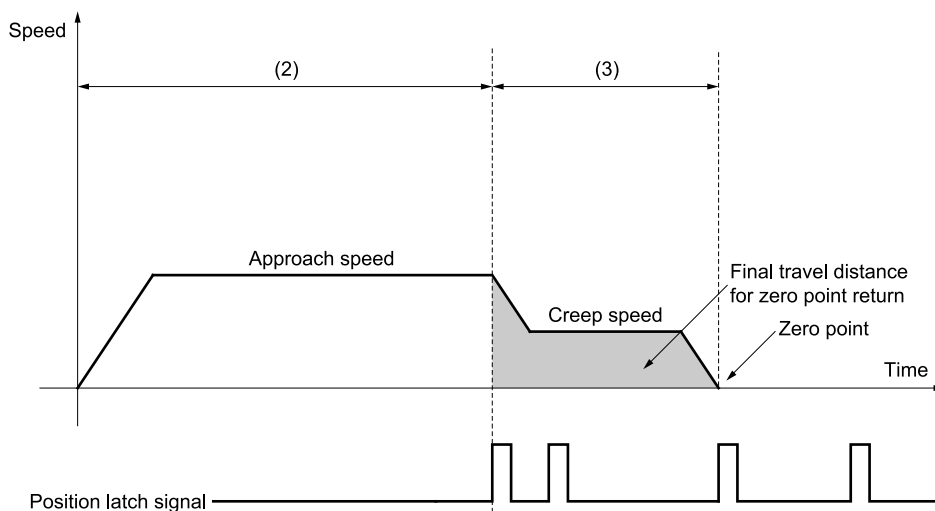

**(b) MODE.TYPE = 1 (Deceleration Limit Switch Signal + Latch Signal)**

No.	Description
1	The MDevice station sends the ZRET command. It selects the latch signal with LT_SEL1 of SVCMD_CTRL and outputs the latch request by setting LT_REQ1 = 1.
2	The SDevice station starts feeding in the specified direction (MODE.HOME_DIR of the ZRET command) at the speed set in the TSPD field.
3	The feed speed is changed to the Zero Point Return Approach Speed (common parameter 84) when SVCMD_IO.DEC = 1 (zero point return deceleration limit switch = ON).
4	When the current position latch signal, specified by LT_SEL1 of SVCMD_CTRL, is input after SVCMD_IO.DEC = 0 (zero point return deceleration limit switch = OFF), the SDevice station executes positioning through the movement of the Final Travel Distance for Homing (common parameter 86) at the Homing Creep Speed (common parameter 85). After the completion of positioning, the SDevice station sets the zero point of the reference coordinate system.

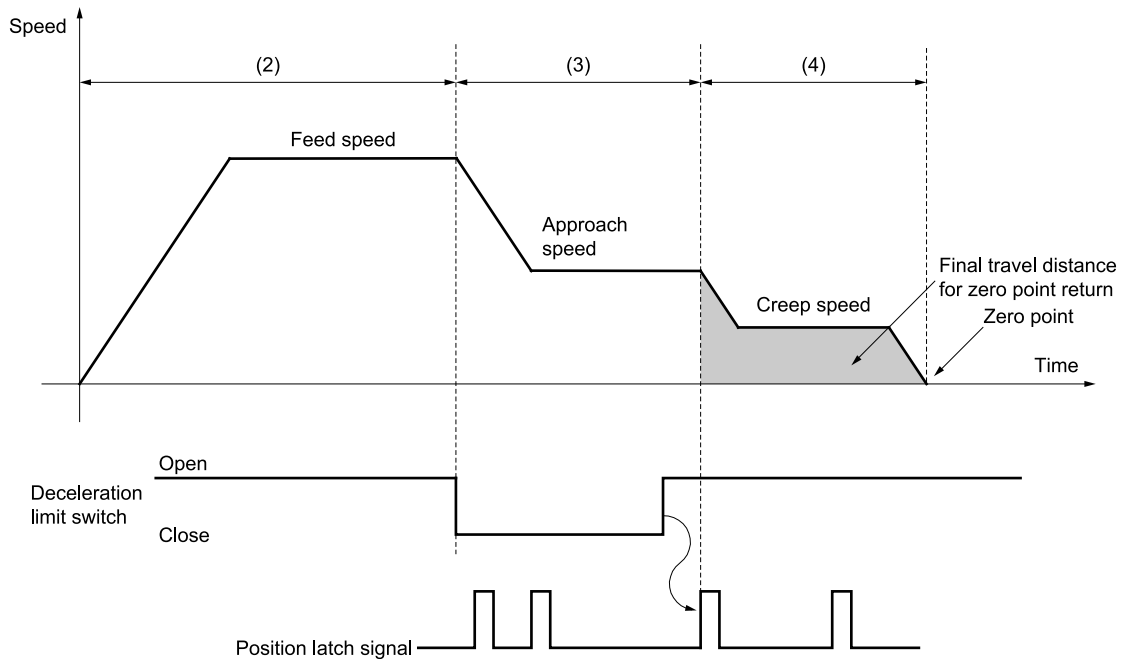

**Information** The motion direction after latching is determined by the sign of the value set for the Final Travel Distance for Homing.

If the Final Travel Distance for Homing is a positive value:

- After latching during motion in the positive direction, the motor rotates in the positive direction (the same direction) for positioning.
- After latching during motion in the negative direction, the motor rotates in the positive direction (the reverse direction) for positioning.  
(With ZRET in the MECHATROLINK-II compatible profile, the motor rotates in the negative direction (the same direction) for positioning.)

If the Final Travel Distance for Homing is a negative value:

- After latching during motion in the positive direction, the motor rotates in the negative direction (the reverse direction) for positioning.
- After latching during motion in the negative direction, the motor rotates in the negative direction (the same direction) for positioning.  
(With ZRET in the MECHATROLINK-II compatible profile, the motor rotates in the positive direction (the reverse direction) for positioning.)

## 3.2.15 Velocity Control Command (VELCTRL: 3Ch)

### (1) Data Format

Communication Phases in which the Command can be Executed		2, 3	Command Classification	Servo standard command	Asynchronous command
Processing Time		Within communications cycle	Subcommand	Can be used	
Byte	VELCTRL		Description		
	Command	Response			
0	3CH	3Ch	<ul style="list-style-type: none"> <li>The VELCTRL command sends the speed reference to an SDevice station to perform speed control. The SDevice station performs speed control directly without position control.</li> <li>To cancel the speed control, set the speed reference as VREF = 0 or set SVCMD_CTRL.CMD_CANCEL to "1."</li> <li>To pause the speed control, set SVCMD_CTRL.CMD_PAUSE to "1."</li> <li>Confirm the completion of the command execution by checking that RCMD = VELCTRL (= 3Ch) and CMD_STAT.CMDRDY = 1.</li> <li>Confirm the completion of command execution canceling by checking that CMD = VELCTRL (= 3Ch), CMD_STAT.CMDRDY = 1, and SVCMD_STAT.CMD_CANCEL_CMP = 1.</li> <li>Confirm the arrival of the feedback speed at the speed reference (VREF) by checking that SVCMD_IO.V_CMP = 1.</li> <li>Confirm the completion of pausing of the command by checking that RCMD = VELCTRL (= 3Ch), CMD_STAT.CMDRDY = 1 and SVCMD_STAT.CMD_PAUSE_CMP = 1.</li> <li>CPRM_SEL_MON1/CPRM_SEL_MON2: Monitor data can be selected by changing the common parameter setting. Refer to the following chapter for details.  <a href="#">☞ 8 Common Parameters on page 187</a></li> </ul> <p>&lt;Notes on using the command&gt;</p> <ul style="list-style-type: none"> <li>VREF (Velocity reference): Set the speed reference with a signed value.</li> <li>TFF (torque feedforward): Set the torque feedforward value with a signed value. Use it as a torque feedforward function.</li> <li>ACCR (acceleration): Set the acceleration with an unsigned value.</li> <li>DECR (deceleration): Set the deceleration with an unsigned value.</li> <li>TLIM (torque limit): Set the torque limit with an unsigned value.</li> <li>Refer to the following section for the above reference data.  <a href="#">☞ 3.2.19 Motion Command Data Setting Method on page 125</a></li> <li>Refer to the following section for the reference value units in the command area.  <a href="#">☞ 2.6.2 Specifying Units on page 76</a></li> <li>If the command is sent in the servo OFF state (SVON = 0), the command becomes effective next time the servo ON state (SVON = 1) is established.</li> </ul> <p>In the following cases, an alarm will occur and the command will not be executed.</p> <ul style="list-style-type: none"> <li>When the ACCR or DECR data is invalid: CMD_ALM = 9h (A.94B)</li> </ul> <p>In the following case, an alarm will occur and the relevant value will be clamped at the limit value.</p> <ul style="list-style-type: none"> <li>When the VREF data is invalid: CMD_ALM = 1h (A.94B)</li> <li>When the TLIM data is invalid: CMD_ALM = 1h (A.97B)</li> </ul>		
1	WDT	RWDT			
2	CMD_CTRL	CMD_STAT			
3					
4 to 7	SVCMD_CTRL	SVCMD_STAT			
8 to 11	SVCMD_IO	SVCMD_IO			
12 to 15	TFF	CPRM_SEL_MON1			
16 to 19	VREF	CPRM_SEL_MON2			
20 to 23	ACCR	MONITOR1			
24 to 27	DECR	MONITOR2			
28 to 31	TLIM	MONITOR3			

## 3.2.16 Torque Control Command (TRQCTRL: 3Dh)

### (1) Data Format

Communication Phases in which the Command can be Executed		2, 3		Command Classification	Servo standard command	Asynchronous command
Processing Time		Within communications cycle		Subcommand	Can be used	
Byte	TRQCTRL		Description			
	Command	Response				
0	3DH	3Dh	<ul style="list-style-type: none"> <li>The TRQCTRL command sends the torque reference to an SDevice station to perform torque control. The SDevice station performs torque control directly without speed control and position control.</li> <li>Confirm the completion of the command execution by checking that RCMD = TRQCTRL (= 3Dh) and CMD_STAT.CMDRDY = 1.</li> <li>CPRM_SEL_MON1/CPRM_SEL_MON2: Monitor data can be selected by changing the common parameter setting. Refer to the following chapter for details.  <a href="#">8 Common Parameters on page 187</a></li> </ul> <Notes on using the command> <ul style="list-style-type: none"> <li>TQREF (torque reference): Set the torque reference with a signed value.</li> <li>VLIM (Velocity limit): Set the speed limit with an unsigned value.</li> <li>Refer to the following section for the above reference data.  <a href="#">3.2.19 Motion Command Data Setting Method on page 125</a></li> <li>Refer to the following section for the reference value units in the command area.  <a href="#">2.6.2 Specifying Units on page 76</a></li> <li>If the command is sent in the servo OFF state (SVON = 0), the command becomes effective next time the servo ON state (SVON = 1) is established.</li> </ul> In the following case, an alarm will occur and the relevant value will be clamped at the limit value. <ul style="list-style-type: none"> <li>When the TQREF data is invalid: CMD_ALM = 1h (A.97B)</li> <li>When the VLIM data is invalid: CMD_ALM = 1h (A.97B)</li> </ul>			
1	WDT	RWDT				
2	CMD_CTRL	CMD_STAT				
3						
4 to 7	SVCMD_CTRL	SVCMD_STAT				
8 to 11	SVCMD_IO	SVCMD_IO				
12 to 15	VLIM	CPRM_SEL_MON1				
16 to 19	TQREF	CPRM_SEL_MON2				
20 to 23	Reserved	MONITOR1				
24 to 27		MONITOR2				
28 to 31		MONITOR3				

### 3.2.17 Read Servo Parameter Command (SVPRM\_RD: 40h)

#### (1) Data Format

Communication Phases in which the Command can be Executed		2, 3	Command Classification	Servo standard command	Asynchronous command
Processing Time		Within 200 ms	Subcommand	Cannot be used	
Byte	SVPRM_RD		Description		
	Command	Response			
0	40h	40h	<ul style="list-style-type: none"> <li>The SVPRM_RD command reads the servo parameters on specification of the servo parameter number, data size, and the read mode.</li> <li>Select the parameter type (common parameter or device parameter) in the read mode to read the corresponding servo parameter.</li> <li>Confirm the completion of the command execution by checking that RCMD = SVPRM_RD (= 40h) and CMD_STAT.CMDRDY = 1, and also checking the setting for NO, SIZE and MODE.</li> </ul> <p>In the following cases, an alarm will occur. Do not read PARAMETER in the response in these cases because the PARAMETER value will be indefinite.</p> <ul style="list-style-type: none"> <li>When the NO data is invalid: MD_ALM = 9h (A.94A)</li> <li>When the SIZE data is invalid: MD_ALM = 9h (A.94D)</li> <li>When the MODE data is invalid: MD_ALM = 9h (A.94B)</li> <li>While editing using SigmaWin or digital operator: CMD_ALM = Ah (A.95A)</li> </ul>		
1	WDT	RWDT			
2	CMD_CTRL	CMD_STAT			
3					
4 to 7	SVCMD_CTRL	SVCMD_STAT			
8 to 11	SVCMD_IO	SVCMD_IO			
12 to 13	NO	NO			
14	SIZE	SIZE			
15	MODE	MODE			
16 to 31	Reserved.	PARAMETER			

#### (2) Command Parameters

##### (a) NO

Servo parameter number

##### (b) SIZE

Servo parameter data size [byte]

##### (c) MODE

Servo parameter read mode

Servo Parameter Type	Reading Source	Mode Setting
Common parameters	RAM area	00h
Device parameter	RAM area	10h

##### (d) PARAMETER

Servo parameter data

### 3.2.18 Write Servo Parameter Command (SVPRM\_WR: 41h)

#### (1) Data Format

Communication Phases in which the Command can be Executed	2, 3		Command Classification	Servo standard command	Asynchronous command
Processing Time	Within 200 ms		Subcommand	Cannot be used	
Byte	SVPRM_WR		Description		
	Command	Response			
0	41h	41h	<ul style="list-style-type: none"> <li>The SVPRM_WR command writes the servo parameters on specification of the servo parameter number, data size, and write mode.</li> <li>Select the parameter type (common parameter or device parameter) and the writing destination (RAM area or retentive memory area) in the write mode to write the corresponding servo parameter.</li> <li>When specifying offline parameters, the CONFIG command must be sent to set up after the parameters are written. However, the following parameters are not enabled even if the CONFIG command is sent. You must turn the power supply OFF and ON again after you change either of these parameters. <ul style="list-style-type: none"> <li>Pn002 = n.X□□□ (External Encoder Usage)</li> <li>Pn00C (Application Function Selections C)</li> </ul> </li> <li>Confirm the completion of the command execution by checking that RCMD = SVPRM_WR (= 41h) and CMD_STAT.CMDRDY = 1, and also checking the setting for NO, SIZE, MODE and PARAMETER.</li> </ul> <p>In the following cases, an alarm will occur and the command will not be executed.</p> <ul style="list-style-type: none"> <li>When the NO data is invalid: MD_ALM = 9h (A.94A)</li> <li>When the SIZE data is invalid: MD_ALM = 9h (A.94D)</li> <li>When the MODE data is invalid: MD_ALM = 9h (A.94B)</li> <li>When the PARAMETER data is invalid: CMD_ALM = 9h (A.94B)</li> <li>While editing using SigmaWin or digital operator: CMD_ALM = Ah (A.95A)</li> </ul>		
1	WDT	RWDT			
2	CMD_CTRL	CMD_STAT			
3					
4 to 7	SVCMD_CTRL	SVCMD_STAT			
8 to 11	SVCMD_IO	SVCMD_IO			
12 to 13	NO	NO			
14	SIZE	SIZE			
15	MODE	MODE			
16 to 31	PARAMETER	PARAMETER			

#### (2) Command Parameters

##### (a) NO

Servo parameter number

##### (b) SIZE

Servo parameter data size [byte]

##### (c) MODE

Servo parameter write mode

Servo Parameter Type	Writing Destination	Mode Setting
Common parameters	RAM area	00h
	Nonvolatile memory area	01h
Device parameter	RAM area	10h
	Nonvolatile memory area	11h

##### (d) PARAMETER

Servo parameter data

### 3.2.19 Motion Command Data Setting Method

This subsection provides information on the settings of the following data fields of the motion commands: TSPD, VREF, VFF, TREF, TFF, TLIM, VLIM, ACCR and DECR.

Name	Description	Setting	CMD_ALM Warning Code	Operation due to Setting Data
TSPD	Target speed	FEED and EX_FEED: Set signed 4-byte data.		
		-Maximum commandable speed *1 to +maximum commandable speed	0h Normal	Operates according to the setting.
		Other than above	9h A.94B	Ignores the command and continues the previous command.
		POSING, EX_POSING, and ZRET: Set unsigned 4-byte data.		
		0 to maximum commandable speed and also TSPD ≤ 7FFFFFFFh	0h Normal	Operates according to the setting.
		Other than above	9h A.94B	Ignores the command and continues the previous command.
VREF VFF	Velocity reference, Velocity feed-forward value	Set signed 4-byte data.		
		- Maximum output speed *2 to +maximum output speed	0h Normal	Operates according to the setting.
		Other than above	1h A.97B	Operates with the speed clamped at the maximum output speed.
TQREF TFF	Torque reference, Torque feed-forward value	Set signed 4-byte data.		
		- Maximum torque to +Maximum torque	0h Normal	Operates according to the setting.
		Other than above	1h A.97B	Operates with the torque clamped at the maximum torque.
TLIM	Torque limit	Set the limit with unsigned 4-byte data.		
		0 to maximum torque	0h Normal	Operates according to the setting.
		Maximum torque or greater	1h A.97B	Operates with the torque clamped at the maximum torque.
		80000000h to FFFFFFFEh	1h A.97B	SERVOPACK processes as TLIM = 7FFFFFFFh internally.
		FFFFFFFh	0h Normal	No torque limit applies. (The torque is clamped at the maximum torque and the alarm CMD_ALM does not occur.)
VLIM	Speed limit	Set the limit with unsigned 4-byte data.		
		0 to maximum output speed *2	0h Normal	Operates according to the setting.
		Maximum output speed or greater	1h A.97B	Operates with the speed clamped at the maximum output speed.
		80000000h to FFFFFFFEh	1h A.97B	SERVOPACK processes as VLIM = 7FFFFFFFh internally.
		FFFFFFFh	0h Normal	No speed limit applies. (The speed is clamped at the maximum output speed and the alarm CMD_ALM does not occur.)

Continued on next page.

Name	Description	Setting	CMD_ALM Warning Code	Operation due to Setting Data
ACCR DECR	Acceleration, Deceleration (position control)	Set the acceleration/deceleration with unsigned 4-byte data.		
		1 to Maximum acceleration *3 Maximum deceleration	0h Normal	Operates according to the setting.
		Maximum acceleration or greater Maximum deceleration or greater	1h A.94B	Ignores the command and continues the previous command.
		0, 80000000h to FFFFFFFEh	1h A.94B	Ignores the command and continues the previous command.
		FFFFFFFFh	1h A.94B	Operates at the maximum acceleration/deceleration and the alarm CMD_ALM does not occur.
		ACCR and DECR are both 0	0h Normal	Acceleration/deceleration is performed according to the parameter settings.
		ACCR DECR	Acceleration Deceleration (speed control)	Set the acceleration/deceleration with unsigned 4-byte data. Unit: $\times 10^n$ [Reference units/s <sup>2</sup> ]
1 to Maximum acceleration Maximum deceleration	0h Normal			Operates according to the setting.
Maximum acceleration or greater Maximum deceleration or greater	1h A.94B			Ignores the command and continues the previous command.
0, 80000000h to FFFFFFFEh	1h A.94B			Ignores the command and continues the previous command.
FFFFFFFFh	0h Normal			Operates at the maximum acceleration/deceleration and the alarm CMD_ALM does not occur.
ACCR and DECR are both 0	1h A.94B			Ignores the command and continues the previous command.

\*1  $\Sigma$ -7 SERVOPACKs: Maximum commandable speed = 7D000000h [reference units/s]

$\Sigma$ -X SERVOPACKs: Maximum commandable speed = 3E8000000h [pulses/s]

\*2 Maximum output speed = Common parameter 05

\*3 Maximum acceleration/deceleration = 30D40000h [reference unit/s<sup>2</sup>]

### 3.2.20 Restrictions in Using Servo Commands

#### (1) Travel Distance Restrictions for the ZRET, EX\_POSING, and EX\_FEED Commands

If you use the ZRET (Zero Point Return), EX\_POSING (External Input Positioning), or EX\_FEED (External Input Feed) command for a  $\Sigma$ -7/ $\Sigma$ -X-series rotary servomotor, the following restrictions apply according to the setting of the electronic gear ratio and resolution of the servomotor.

Electric Gear Ratio (Pn20E/Pn210)	Travel Distance	
	Servomotor Resolution: 24 Bits	Servomotor Resolution: 26 Bits
1/1	Distance equivalent to $\pm 64$ rotations	Distance equivalent to $\pm 16$ rotations
2/1	Distance equivalent to $\pm 128$ rotations	Distance equivalent to $\pm 32$ rotations
4/1	Distance equivalent to $\pm 256$ rotations	Distance equivalent to $\pm 64$ rotations
16/1	Distance equivalent to $\pm 1024$ rotations	Distance equivalent to $\pm 256$ rotations
64/1	Distance equivalent to $\pm 4096$ rotations	Distance equivalent to $\pm 1024$ rotations

## (2) Travel Distance Restrictions for the TPOS (Target Position) Command

If you use TPOS (Target Position) for a  $\Sigma$ -7/ $\Sigma$ -X-series rotary servomotor, the following restrictions apply according to the setting of the electronic gear ratio and the servomotor resolution.

Electric Gear Ratio (Pn20E/Pn210)	Travel Distance	
	Servomotor Resolution: 24 Bits	Servomotor Resolution: 26 Bits
1/1	Distance equivalent to $\pm 128$ rotations	Distance equivalent to $\pm 32$ rotations
2/1	Distance equivalent to $\pm 256$ rotations	Distance equivalent to $\pm 64$ rotations
4/1	Distance equivalent to $\pm 512$ rotations	Distance equivalent to $\pm 256$ rotations
16/1	Distance equivalent to $\pm 2048$ rotations	Distance equivalent to $\pm 512$ rotations
64/1	Distance equivalent to $\pm 8192$ rotations	Distance equivalent to $\pm 2048$ rotations

## (3) TSPD (Target Speed) Restrictions: $\Sigma$ -7-Series Only

If you are using  $\Sigma$ -7-series SERVOPACKs, the servomotor cannot accelerate to TSPD (Target Speed) specified by the command during positioning or when the deceleration distance exceeds 1073741823 reference units. Set deceleration in the parameter as follows:

Deceleration [reference unit/s<sup>2</sup>]  $\geq$  Maximum reference speed [reference unit/s]<sup>2</sup> / (Maximum deceleration distance [reference unit]  $\times$  2)

## (4) Deceleration Time Restrictions during Position Control: $\Sigma$ -7-Series Only

If you use a positioning command (i.e., POSING, FEED, EX\_FEED, EX\_POSING, or ZRET) for a  $\Sigma$ -7-series rotary servomotor (resolution: 24 bits), the following restrictions apply to the deceleration time.

Electric Gear Ratio (Pn20E/Pn210)	Deceleration Time [s]			
	at 750 min <sup>-1</sup>	at 1500 min <sup>-1</sup>	at 3000 min <sup>-1</sup>	at 6000 min <sup>-1</sup>
1/1	10.24	5.12	2.56	1.28
2/1	20.48	10.24	5.12	2.56
4/1	40.96	20.48	10.24	5.12
16/1	163.84	81.92	40.96	20.48

The following figure shows the relationship between the reference speed and deceleration time.

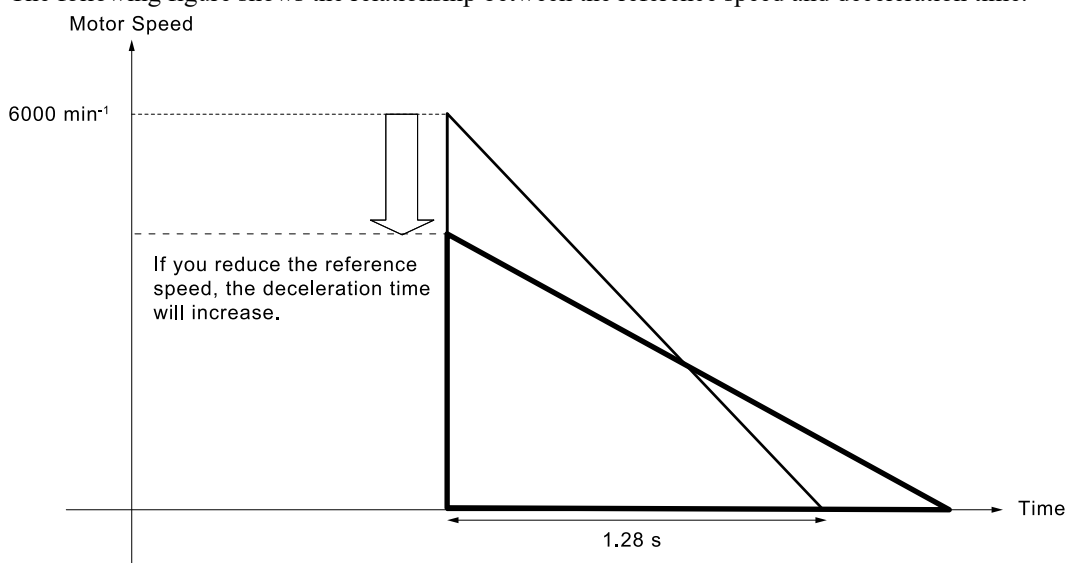



# Subcommands

---

<b>4.1</b>	<b>Servo Commands .....</b>	<b>130</b>
4.1.1	No Operation Subcommand (NOP: 00h).....	130
4.1.2	Read Alarm or Warning Subcommand (ALM_RD: 05h) .....	131
4.1.3	Clear Alarm or Warning Subcommand (ALM_CLR: 06h).....	132
4.1.4	Read Memory Subcommand (MEM_RD: 1Dh) .....	133
4.1.5	Write Memory Subcommand (MEM_WR: 1Eh) .....	134
4.1.6	Servo Status Monitor Subcommand (SMON: 30h).....	135
4.1.7	Read Servo Parameter Subcommand (SVPRM_RD: 40h) .....	136
4.1.8	Write Servo Parameter Subcommand (SVPRM_WR: 41h) .....	137

## 4.1 Servo Commands

### 4.1.1 No Operation Subcommand (NOP: 00h)

#### (1) Data Format

Communication Phases in which the Command can be Executed		All phases	Command Classification	Common command	Asynchronous command
Processing Time		Within communication cycle			
Byte	NOP		Description		
	Command	Response			
32	00h	00h	<ul style="list-style-type: none"> <li>The NOP subcommand is used for network control.</li> <li>Confirm the completion of the subcommand execution by checking that <code>RSUBCMD = NOP (= 00h)</code> and <code>SUB_STAT.SBCMDRDY = 1</code>.</li> </ul>		
33	SUB_CTRL	SUB_STAT			
34					
35					
36	Reserved.	Reserved.			
37					
38					
39					
40					
41					
42					
43					
44					
45					
46					
47					

## 4.1.2 Read Alarm or Warning Subcommand (ALM\_RD: 05h)

### (1) Data Format

Communication Phases in which the Command can be Executed		2, 3	Command Classification	Common command	Asynchronous command
Processing Time		Within 200 ms			
Byte	ALM_RD		Description		
	Command	Response			
32	05h	05h	<ul style="list-style-type: none"> <li>The ALM_RD subcommand reads the current alarm or warning state as an alarm or warning code.</li> <li>Confirm the completion of the subcommand execution by checking that RSUBCMD = ALM_RD (= 05h) and SUB_STAT.SBCMDRDY = 1.</li> <li>ALM_INDEX is not used. Its setting is ignored.</li> </ul> In the following cases, an alarm will occur and the subcommand will not be executed. <ul style="list-style-type: none"> <li>When the ALM_RD_MOD data is invalid: SUBCMD_ALM = 9h (A.94B)</li> </ul>		
33	SUB_CTRL	SUB_STAT			
34					
35					
36	ALM_RD_MOD	ALM_RD_MOD			
37					
38	ALM_INDEX	ALM_INDEX			
39					
40	Reserved.	ALM_DATA			
41					
42					
43					
44					
45					
46					
47					

**Note:**

1. ALM\_DATA specifies an alarm using 2 bytes.
2. The most recent alarms come first in the history data.
3. Normal status is indicated by 0000h.

### (2) Command Parameters

#### (a) ALM\_RD\_MOD

ALM_RD_MOD	Description
0	Current alarm or warning state Maximum of 4 records (from byte 40 to byte 47)
1	Alarm occurrence status history (Warnings are not retained in the history.) Maximum of 4 records (from byte 40 to byte 47)

For  $\Sigma$ -7/ $\Sigma$ -X-series SERVOPACKs, alarm codes are defined as 2-byte data with the following configuration.

	Bits 15 to 12	Bits 11 to 0
	0	Alarm Code
Example for A.94B	0h	94Bh

### 4.1.3 Clear Alarm or Warning Subcommand (ALM\_CLR: 06h)

#### (1) Data Format

Communication Phases in which the Command can be Executed		2, 3	Command Classification	Common command	Asynchronous command
Processing Time		 (2) Command Parameters on page 132			
Byte	ALM_CLR		Description		
	Command	Response			
32	06h	06h	<ul style="list-style-type: none"> <li>The ALM_CLR subcommand clears the alarm or warning state. It changes the state of an SDevice station, but does not eliminate the cause of the alarm or warning. ALM_CLR should be used to clear the state after the cause of the alarm or warning has been eliminated.</li> <li>Confirm the completion of the subcommand execution by checking that RSUBCMD = ALM_CLR (= 06h) and SUB_STAT.SBCMDRDY = 1.</li> </ul> <p>In the following cases, an alarm will occur and the command will not be executed.</p> <ul style="list-style-type: none"> <li>When the ALM_CLR_MOD data is invalid: SUBCMD_ALM = 9h (A.94B)</li> <li>While editing using SigmaWin or digital operator: SUBCMD_ALM = Ah (A.95A)</li> </ul>		
33	SUB_CTRL	SUB_STAT			
34					
35					
36	ALM_CLR_MOD	ALM_CLR_MOD			
37					
38	Reserved.	Reserved.			
39					
40					
41					
42					
43					
44					
45					
46					
47					

#### (2) Command Parameters

##### (a) ALM\_CLR\_MOD

ALM_CLR_MOD	Description	Processing Time
0	Clearance of the current alarm or warning state	Within 200 ms
1	Clearance of the alarm history	Within 2 s

## 4.1.4 Read Memory Subcommand (MEM\_RD: 1Dh)

### (1) Data Format

Communication Phases in which the Command can be Executed		2, 3	Command Classification	Common command	Asynchronous command
Processing Time		Within 200 ms			
Byte	MEM_RD		Description		
	Command	Response			
32	1Dh	1Dh	<ul style="list-style-type: none"> <li>The MEM_RD subcommand reads the data stored in virtual memory by specifying the initial address and the data size for reading.</li> <li>Confirm the completion of the subcommand execution by checking that RSUBCMD = MEM_RD (= 1Dh) and SUB_STAT.SUBCMDRDY = 1, and also checking the setting for ADDRESS and SIZE.</li> </ul> <p>In the following cases, an alarm will occur and the subcommand will not be executed.</p> <ul style="list-style-type: none"> <li>When the ADDRESS data is invalid: SUBCMD_ALM = 9h (A.94A)</li> <li>When the MODE/DATA_TYPE data is invalid: SUBCMD_ALM = 9h (A.94B)</li> <li>When the SIZE data is invalid: SUBCMD_ALM = 9h (A.94D)</li> <li>While editing using SigmaWin or digital operator: SUBCMD_ALM = Ah (A.95A)</li> </ul> <p>Refer to the following chapter for details.</p> <p> (4) <i>Method to Access Virtual Memory Areas on page 100</i></p>		
33	SUB_CTRL	SUB_STAT			
34					
35					
36	Reserved (0)	Reserved (0)			
37	MODE/DATA_TYPE	MODE/DATA_TYPE			
38	SIZE	SIZE			
39					
40	ADDRESS	ADDRESS			
41					
42					
43					
44	Reserved.	DATA			
45					
46					
47					

### (2) Command Parameters

#### (a) MODE/DATA\_TYPE

Bit 7	Bit 6	Bit 5	Bit 4	Bit 3	Bit 2	Bit 1	Bit 0
MODE 1: Volatile memory, 2: Not supported				DATA_TYPE 1: Byte, 2: Short, 3: Long, 4: Not supported			

#### (b) SIZE

Data size for reading (of type specified by DATA\_TYPE)

#### (c) ADDRESS



Initial address for writing

#### (d) DATA

DATA: Read data

## 4.1.5 Write Memory Subcommand (MEM\_WR: 1Eh)

### (1) Data Format

Communication Phases in which the Command can be Executed		2, 3	Command Classification	Common command	Asynchronous command
Processing Time		 (3) Executing the Adjustment Operation on page 99			
Byte	MEM_WR		Description		
	Command	Response			
32	1Eh	1Eh	<ul style="list-style-type: none"> <li>The MEM_WR subcommand writes the data in virtual memory by specifying the initial address, the data size and the data for writing.</li> <li>This subcommand provides an adjustment function equivalent to that of the ADJ command of the MECHATROLINK-II compatible profile. For the operation procedure, refer to the MEM_WR main command.</li> <li>Confirm the completion of the subcommand execution by checking that RSUBCMD = MEM_WR (= 1Eh) and SUB_STAT.SUBCMDRDY = 1, and also checking the setting for ADDRESS, SIZE and DATA.</li> </ul> <p>In the following cases, an alarm will occur and the subcommand will not be executed.</p> <ul style="list-style-type: none"> <li>When the ADDRESS data is invalid: SUBCMD_ALM = 9h (A.94A)</li> <li>When the MODE/DATA_TYPE data is invalid: SUBCMD_ALM = 9h (A.94B)</li> <li>When the SIZE data is invalid: SUBCMD_ALM = 9h (A.94D)</li> <li>When the conditions for executing the adjustment operation are not satisfied: SUBCMD_ALM = Ah (A.95A)</li> <li>While editing using SigmaWin or digital operator: SUBCMD_ALM = Ah (A.95A)</li> </ul> <p>Refer to the following chapter for details.</p> <p> (4) Method to Access Virtual Memory Areas on page 100</p>		
33	SUB_CTRL	SUB_STAT			
34					
35					
36	Reserved (0)	Reserved (0)			
37	MODE/DATA_TYPE	MODE/DATA_TYPE			
38	SIZE	SIZE			
39					
40	ADDRESS	ADDRESS			
41					
42					
43					
44	DATA	DATA			
45					
46					
47					

### (2) Command Parameters

#### (a) MODE/DATA\_TYPE

Bit 7	Bit 6	Bit 5	Bit 4	Bit 3	Bit 2	Bit 1	Bit 0
MODE				DATA_TYPE			
1: Volatile memory, 2: Non-volatile memory (Non-volatile memory can be selected only for common parameters.)				1: Byte, 2: Short, 3: Long, 4: Not supported			

#### (b) SIZE

Data size for reading (of type specified by DATA\_TYPE)

#### (c) ADDRESS

Initial address for writing

#### (d) DATA

Data to be written

## 4.1.6 Servo Status Monitor Subcommand (SMON: 30h)

### (1) Data Format

Communication Phases in which the Command can be Executed		2, 3	Command Classification	Common command	Asynchronous command
Processing Time		Within communication cycle			
Byte	SMON		Description		
	Command	Response			
32	30h	30h	<ul style="list-style-type: none"> <li>The SMON subcommand reads the alarms, status, and monitor information (position, speed, output, torque, etc.) specified in monitor setting, and the state of the I/O signals of the servo drive.</li> <li>Confirm the completion of the subcommand execution by checking that RSUBCMD = SMON (= 30h) and SUB_STAT.SUBCMDRDY = 1.</li> </ul>		
33	SUB_CTRL	SUB_STAT			
34					
35					
36	Reserved.	MONITOR4			
37					
38					
39					
40		MONITOR5			
41					
42					
43		MONITOR6			
44					
45					
46					
47					

## 4.1.7 Read Servo Parameter Subcommand (SVPRM\_RD: 40h)

### (1) Data Format

Communication Phases in which the Command can be Executed		2, 3	Command Classification	Servo standard command	Asynchronous command
Processing Time		Within 200 ms			
Byte	SVPRM_RD		Description		
	Command	Response			
32	40h	40h	<ul style="list-style-type: none"> <li>The SVPRM_RD subcommand reads the servo parameters on specification of the servo parameter number, data size, and the read mode.</li> <li>Confirm the completion of the subcommand execution by checking that RSUBCMD = SVPRM_RD (= 40h) and SUB_STAT.SUBCMDRDY = 1, and also checking the setting for NO, SIZE and MODE.</li> </ul> <p>In the following cases, an alarm will occur. Do not read PARAMETER in the response in these cases because the PARAMETER value will be indefinite.</p> <ul style="list-style-type: none"> <li>When the NO data is invalid: SUBCMD_ALM = 9h (A.94A)</li> <li>When the SIZE data is invalid: SUBCMD_ALM = 9h (A.94D)</li> <li>When the MODE data is invalid: SUBCMD_ALM = 9h (A.94B)</li> <li>While editing using SigmaWin or digital operator: SUBCMD_ALM = Ah (A.95A)</li> </ul>		
33	SUB_CTRL	SUB_STAT			
34					
35					
36	NO	NO			
37					
38	SIZE	SIZE			
39	MODE	MODE			
40	Reserved.	PARAMETER			
41					
42					
43					
44					
45					
46					
47					

### (2) Command Parameters

#### (a) NO

Servo parameter number

#### (b) SIZE

Servo parameter data size [byte]

#### (c) MODE

Servo parameter read mode

Servo Parameter Type	Reading Source	Mode Setting
Common Parameters	RAM area	00h
Device Parameter	RAM area	10h

#### (d) PARAMETER

Servo parameter data

## 4.1.8 Write Servo Parameter Subcommand (SVPRM\_WR: 41h)

### (1) Data Format

Communication Phases in which the Command can be Executed		2, 3	Command Classification	Servo standard command	Asynchronous command
Processing Time		Within 200 ms			
Byte	SVPRM_WR		Description		
	Command	Response			
32	41h	41h	<ul style="list-style-type: none"> <li>The SVPRM_WR command writes the servo parameters on specification of the servo parameter number, data size, and write mode.</li> <li>Confirm the completion of the subcommand execution by checking that RSUBCMD = SVPRM_WR (= 41h) and SUB_STAT.SUBCMDRDY = 1, and also checking the setting for NO, SIZE, MODE and PARAMETER.</li> </ul> <p>In the following cases, an alarm will occur and the subcommand will not be executed.</p> <ul style="list-style-type: none"> <li>When the NO data is invalid: SUBCMD_ALM = 9h (A.94A)</li> <li>When the SIZE data is invalid: SUBCMD_ALM = 9h (A.94D)</li> <li>When the MODE data is invalid: SUBCMD_ALM = 9h (A.94B)</li> <li>When the PARAMETER data is invalid: SUBCMD_ALM = 9h (A.94B)</li> <li>While editing using SigmaWin or digital operator: SUBCMD_ALM = Ah (A.95A)</li> </ul>		
33	SUB_CTRL	SUB_STAT			
34					
35					
36	NO	NO			
37					
38	SIZE	SIZE			
39	MODE	MODE			
40	PARAMETER	PARAMETER			
41					
42					
43					
44					
45					
46					
47					

**Note:**

If the main command and subcommand specifying the same NO are received at the same time as new commands, the main command takes precedence and the alarm specified by SUBCMD\_ALM occurs for the subcommand.

### (2) Command Parameters

**(a) NO**

Servo parameter number

**(b) SIZE**

Servo parameter data size [byte]

**(c) MODE**

Servo parameter write mode

Servo Parameter Type	Reading Source	Mode Setting
Common Parameters	RAM area	00h
	Nonvolatile memory area	01h
Device Parameter	RAM area	10h
	Nonvolatile memory area	11h

**(d) PARAMETER**

Servo parameter data

# Operation Sequence

---

This chapter describes basic operation sequences using MECHATROLINK-III communications.

<b>5.1</b>	<b>Preparing for Operation</b> .....	<b>140</b>
<b>5.2</b>	<b>Parameter Management and Operation Sequence</b> .....	<b>141</b>
5.2.1	Operation Sequence for Managing Parameters Using a Controller .....	141
5.2.2	Operation Sequence for Managing Parameters Using a SERVOPACK .....	141
<b>5.3</b>	<b>Setting the Zero Point before Starting Operation</b> .....	<b>143</b>
5.3.1	When Using an Incremental Encoder .....	143
5.3.2	When Using an Absolute Encoder .....	143
<b>5.4</b>	<b>Operation Sequence when Turning the Servo ON</b> .....	<b>144</b>
<b>5.5</b>	<b>Operation Sequence when OT (Overtravel Limit Switch) Signal Is Input</b> .....	<b>145</b>
5.5.1	Operating Sequence When the Overtravel Alarm Is Used .....	145
<b>5.6</b>	<b>Operation Sequence at Emergency Stop (Main Circuit OFF)</b> .....	<b>147</b>
<b>5.7</b>	<b>Operation Sequence When a Safety Signal Is Input</b> .....	<b>148</b>
5.7.1	When an HWBB Signal Is Input .....	148
5.7.2	Recovery from Stop Status .....	149
<b>5.8</b>	<b>Operation Sequence at Occurrence of Alarm</b> .....	<b>150</b>
<b>5.9</b>	<b>Notes When the Positioning Completed State (PSET = 1) Is Estab- lished While Canceling a Motion Command</b> .....	<b>151</b>

## 5.1 Preparing for Operation

Before starting communications, configure the communications settings and check the communications status.

<b>Overview of Preparing for Operation</b>	<b>Description</b>
Communications Settings	Configure the node address, number of transmission bytes, and other settings using the DIP switches and rotary switches on the SERVOPACK.
Check the Communications Status	Check the communications status using the SERVOPACK LEDs.

For details on the settings and checking the status, refer to the product manual for your SERVOPACK.

## 5.2 Parameter Management and Operation Sequence

### 5.2.1 Operation Sequence for Managing Parameters Using a Controller

When the parameters are managed by a controller, the parameters are automatically transmitted from the controller to the SERVOPACK when the power is turned ON. Therefore, the settings of SERVOPACK do not need to be changed when the SERVOPACK is replaced.

Procedure	Operation	Command to Send
1	Turn ON the control and main circuit power supplies.	–
2	Confirm the completion of the initialization process of the SERVOPACK.	NOP
3	Reset the previous communications status.	DISCONNECT */
4	Establish communications connection and starts WDT count.	CONNECT
5	Check information such as device ID.	ID_RD
6	Read device setting data such as parameters.	SVPRM_RD
7	Set the parameters required for the device.	SVPRM_WR
8	Enable the parameter settings (Setup).	CONFIG
9	Turn ON the encoder power supply to obtain the position data.	SENS_ON
10	Turn the servo ON.	SV_ON
11	Start operation.	POSING, INTERPOLATE, etc.
12	Turn the servo OFF.	SV_OFF
13	Disconnect the communications connection.	DISCONNECT
14	Turn OFF the control and main circuit power supplies.	–

\*1 When starting the operation sequence with turning the power ON as the first step, it is not necessary to send the DISCONNECT command.

**Note:**

This example sequence shows the steps to enable starting of communications regardless of the status at that point.

### 5.2.2 Operation Sequence for Managing Parameters Using a SERVOPACK

To manage the parameters by using SERVOPACK's non-volatile memory, save the parameters in the non-volatile memory at setup and use an ordinary operation sequence.

#### (1) Setup Sequence

Procedure	Operation	Command to Send
1	Turn ON the control and main circuit power supplies.	NOP
2	Reset the previous communications status.	DISCONNECT */
3	Establish communications connection and starts WDT count.	CONNECT
4	Check information such as device ID.	ID_RD
5	Get device setting data such as parameters.	SVPRM_RD

Continued on next page.

Continued from previous page.

Procedure	Operation	Command to Send
6	Save the parameters required for the device in the non-volatile memory.	SVPRM_WR <b>Note:</b> Do not use RAM.
7	Disconnect the communications connection.	DISCONNECT
8	Turn OFF the control and main circuit power supplies.	-

\*1 If the connection cannot be released normally, send a DISCONNECT command for 2 or more communication cycles, and then send a CONNECT command.

## (2) Ordinary Operation Sequence

Procedure	Operation	Command to Send
1	Turn ON the control and main circuit power supplies.	NOP
2	Reset the previous communications status.	DISCONNECT */
3	Establish communications connection and starts WDT count.	CONNECT
4	Check information such as device ID.	ID_RD
5	Get device setting data such as parameters.	SVPRM_RD
6	Turn ON the encoder power supply to obtain the position data.	SENS_ON
7	Turn the servo ON.	SV_ON
8	Start operation.	POSING, INTERPOLATE, etc.
9	Turn the servo OFF.	SV_OFF
10	Disconnect the communications connection.	DISCONNECT
11	Turn OFF the control and main circuit power supplies.	-

\*1 If the connection cannot be released normally, send a DISCONNECT command for 2 or more communication cycles, and then send a CONNECT command.

## 5.3 Setting the Zero Point before Starting Operation

### 5.3.1 When Using an Incremental Encoder

When an incremental encoder is used in the SDevice station, carry out a zero point return operation after turning ON the power supply.

After the zero point is set, set the reference coordinate system to determine the work coordinate zero point as required:

#### (1) Setting the Reference Coordinate System Using ZRET Command

Use the ZRET command to return the SDevice station to the zero point and set the reference coordinate system based on the zero point.

#### (2) Setting the Reference Coordinate System Using POS\_SET Command

Use the POS\_SET command to set the reference coordinate system of the SDevice station.

- Perform positioning to the reference position using a positioning command such as EX\_POSING.
- Send the POS\_SET command with POS\_SET\_MOD.POS\_SEL = 0 (APOS), POS\_SET\_MOD.REFE = 1 (enables setting of a reference point), and POS\_DATA = reference position.

SVCMD\_IO.ZPOINT and software limits are enabled after the reference coordinate system has been set.

### 5.3.2 When Using an Absolute Encoder

When an absolute encoder is used in the SDevice station, the SENS\_ON command can be used to set the reference coordinate system of the SDevice station. The reference coordinate system will be set according to the position detected by the absolute encoder and the coordinate system offset of the encoder (i.e., the offset between the encoder's coordinate system and the reference coordinate system (device built-in parameter)).

The relationship between the reference coordinate system (CPOS and APOS), the encoder's coordinate system, and the coordinate system offset of the encoder are shown in the following figure.

CPOS: Reference position

APOS :Feedback position

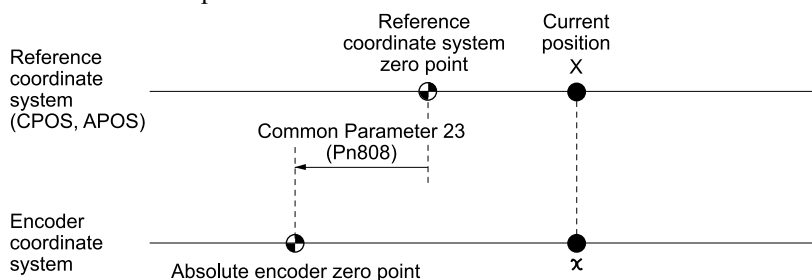

$$X = x + \text{Common Parameter 23 (Pn808)}$$

Common parameter 23 (Pn808): Absolute encoder origin offset

## 5.4 Operation Sequence when Turning the Servo ON

Motor control using a host controller is performed using motion commands only in the servo ON state (motor power ON).

In the servo OFF state (when the power to the motor is shut OFF), the SERVOPACK manages position data so that the reference coordinate system (CPOS, MPOS) and the feedback coordinate system (APOS) are equal. For correct execution of motion commands, therefore, it is necessary to use the SMON (status monitoring) command after the servo ON state has been established, to read the servo reference coordinates (CPOS) and send an appropriate reference position. Set the coordinate system of the SERVOPACK using the POS\_SET (set coordinates) command as necessary.

After completing the setting of the coordinate systems, carry out machine operation using motion commands.

## 5.5 Operation Sequence when OT (Overtravel Limit Switch) Signal Is Input

When an OT signal is input, the SERVOPACK prohibits the motor from rotating in the way specified in parameter Pn001. The motor continues to be controlled by the SERVOPACK while its rotation is prohibited.

When an OT signal is input, use the following procedure to process the OT signal.

Step	Operation
1	Monitor OT signals. When an OT signal is input, send an appropriate stop command: While an interpolation command (INTERPOLATE) is being executed: Continues execution of the interpolation command while stopping updating of the interpolation position. Or, sends an SMON command. While a move command (such as POSING) other than interpolation commands is being executed: Send SVCMD_CTRL.CMD_CANCEL to "1" (cancellation of move command).
2	Check if the SERVOPACK completed the OT processing with SVCMD_IO.DEN = 1 (distribution completed). At the same time, SVCMD_IO.ZSPD = 1 (zero speed detected) can also be checked to detect if the motor is stopped. Keep the command used in step 1 active until both of the above flags are set to 1.
3	Read out the current reference position (CPOS) and use it as the start position for retraction processing.
4	Use a move command such as POSING or INTERPOLATE for retraction processing. Continue to use this command until the retraction is finished. If the move command ends without finishing the retraction, restart the move command continuously from the last target position.



Important

- When an OT signal is input during execution of a motion command such as ZRET, EX\_FEED or EX\_POSING, the execution of the command will be cancelled.
- During the overtravel state (SVCMD\_IO.P-OT = 1 or SVCMD\_IO.N-OT = 1), the servomotor is not positioned to the target position specified by the host controller. Check the feedback position (APOS) to confirm that the axis is stopped at a safe position.
- If the state of an OT signal varies over a short time (in a pulsing manner for example), the host controller may not be able to monitor the variation of the OT signal properly. Take due care about the selection of limit switches and their mounting and wiring to avoid chattering of OT signals and malfunctioning.

### 5.5.1 Operating Sequence When the Overtravel Alarm Is Used

The  $\Sigma$ -X SERVOPACK is equipped with the overtravel alarm. Use the following processing procedure for OT signal input when the overtravel alarm is used.

Step	Operation
1	Monitor OT signals. When an OT signal is input, send an appropriate stop command: While an interpolation command (INTERPOLATE) is being executed: Continues execution of the interpolation command while stopping updating of the interpolation position. Or, sends an SMON command. While a move command (such as POSING) other than interpolation commands is being executed: Send SVCMD_CTRL.CMD_CANCEL to "1" (cancellation of move command).
2	<ul style="list-style-type: none"> <li>• Check if the SERVOPACK completed the OT processing with SVCMD_IO.DEN = 1 (distribution completed).</li> <li>• Check if a SERVOPACK alarm was detected with CMD_STAT.D_ALM.</li> </ul> At the same time, SVCMD_IO.ZSPD = 1 (zero speed detected) can also be checked to detect if the motor is stopped. Keep the command used in step 1 active until both of the above flags are set to 1. When a device-specific alarm has occurred (CMD_STAT.D_ALM = 1), send the SV_OFF command.
3	Send the ALM_CLR command to clear the overtravel alarm.
4	Send the SV_ON command to supply power to the servomotor. */ <b>Note:</b> The servomotor will be powered after it has stopped. For this reason, if the SV_ON command was sent while the servomotor was stopping, wait until the servomotor stops and confirm that the servomotor is powered before proceeding to the next step.

Continued on next page.

Step	Operation
5	Read out the current reference position (CPOS) and use it as the start position for retraction processing.
6	Use a move command such as POSING or INTERPOLATE for retraction processing. Continue to use this command until the retraction is finished. If the move command ends without finishing the retraction, restart the move command continuously from the last target position.

\*1 When the SV\_ON command is sent during the overtravel status (SVCMD\_IO.P-OT = 1 or SVCMD\_IO.N-OT = 1), power is supplied to the servomotor depending on the setting of SERVOPACK parameter Pn00D = n.X□□□ (Overtravel Warning Detection Selection).

Pn00D Set Values and Details		Servomotor Power Status When the SV_ON Command Is Sent during Overtravel
n.0□□□	Do not detect overtravel warnings.	The servomotor will not be powered.
n.1□□□	Detect overtravel warnings.	
n.2□□□	Detect overtravel alarms.	The servomotor will be powered.

Use caution as the behavior when the SV\_ON command is sent during overtravel is not dependent on the setting of Pn001 = n.□□X□ (Overtravel Stopping Method).



Important

- When an OT signal is input during execution of a motion command such as ZRET, EX\_FEED or EX\_POSING, the execution of the command will be cancelled.
- During the overtravel state (SVCMD\_IO.P-OT = 1 or SVCMD\_IO.N-OT = 1), the servomotor is not positioned to the target position specified by the host controller. Check the feedback position (APOS) to confirm that the axis is stopped at a safe position.
- If the state of an OT signal varies over a short time (in a pulsing manner for example), the host controller may not be able to monitor the variation of the OT signal properly. Take due care about the selection of limit switches and their mounting and wiring to avoid chattering of OT signals and malfunctioning.

## 5.6 Operation Sequence at Emergency Stop (Main Circuit OFF)

For circuits incorporating the recommended processing that the control and main circuit power supplies turn OFF on occurrence of an emergency stop, no specific process is required.

For circuits that turn OFF only the main circuit power supply, follow the procedure below.

After `SVCMD_STAT.SV_ON = 0` (servo OFF) or `SVCMD_STAT.PON = 0` (power OFF) is detected, send the `SV_OFF` command. While in an emergency stop state, always monitor the `SERVOPACK` status using a command such as the `SMON` (status monitoring) command.

For recovery from an emergency stop state, follow the action to be taken on occurrence of an alarm.

## 5.7 Operation Sequence When a Safety Signal Is Input

When the HWBB1 or HWBB2 signal is input while the motor is operating, the power supply to the motor is shut OFF forcibly and the motor stops according to the setting of Pn001 = n.□□□X.

- When an HWBB signal is input after the SERVOPACK stops powering the motor

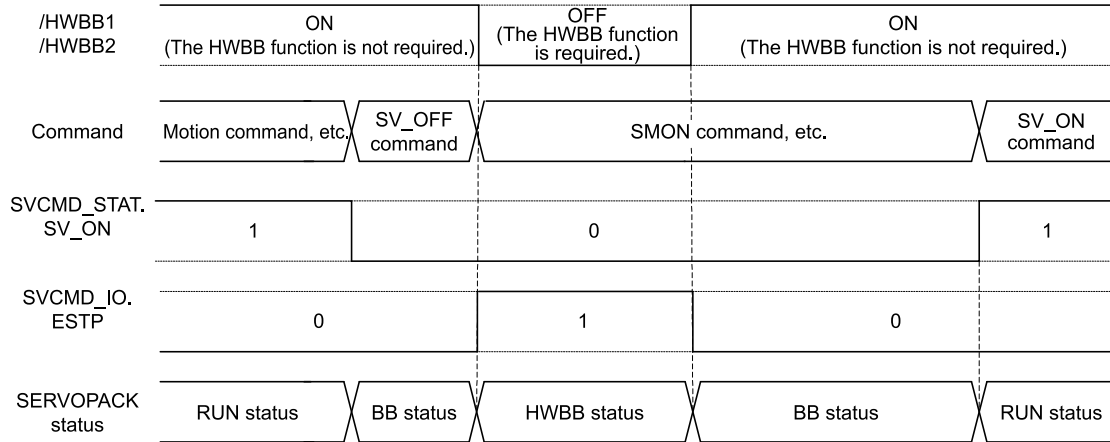

- When an HWBB signal is input while the SERVOPACK is powering the motor

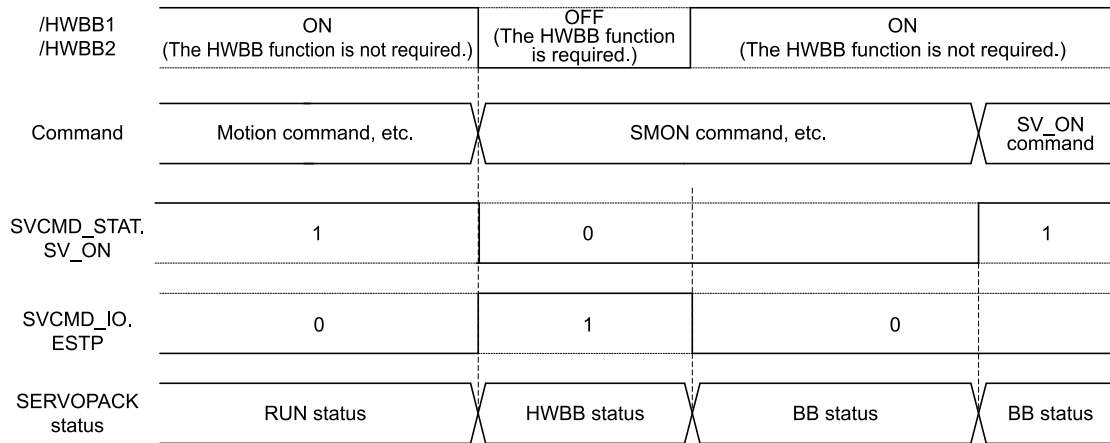

### 5.7.1 When an HWBB Signal Is Input

Monitor the HWBB input signal and EDM1 output signal status, or SVCMD\_IO.ESTP signal. If a forced stop status is detected, send a command such as SV\_OFF to stop the motor.

---

## 5.7.2 Recovery from Stop Status

---

Recover from the stop status by following the procedure below.

1. **Reset the HWBB1 or HWBB2 signal.**  
The HWBB state is still valid at this point.
2. **Send an SV\_OFF command to shift the SERVOPACK to the base block state.**
3. **Carry out controller and system recovery processing.**
4. **Send an SV\_ON command to establish the servo ON state.**
5. **Complete the preparation for operation after establishing the servo ON state.**
6. **Start operation.**

**Note:**

1. If the SERVOPACK enters the HWBB status while sending an SV\_ON command, reset the /HWBB1 or /HWBB2 signal and then send a command other than SV\_ON, such as SV\_OFF. Then, send the SV\_ON command again to restore the normal operation status.
2. If the SERVOPACK enters the HWBB status during execution of an SV\_OFF, INTERPOLATE, POSING, FEED, EX\_FEED, EX\_POSING, or ZRET command, a command warning will occur since the SERVOPACK status changes to the servo OFF state. Execute the clear alarm or warning (ALM\_CLR) command to restore normal operation.

## 5.8 Operation Sequence at Occurrence of Alarm

When `CMD_STAT.D_ALM = 1` or `CMD_STAT.COMM_ALM = 8` or greater, send the `SV_OFF` command.

Use the `ALM_RD` command to check the alarm code that has occurred. To clear the alarm status, send the `ALM_CLR` command or set `CMD_CTRL.ALM_CLR` after eliminating the cause of the alarm. However, this will not clear the alarm status that require the power supply to be turned OFF and back ON for clearance.

- For Communication Error Alarms

When a communication error alarm (`CMD_STAT.COMM_ALM 8`) occurs, the communication phase shifts to phase 2. To restore communication phase 3, send a `SYNC_SET` command after resetting the alarm.

- For Warnings

When the `CMD_STAT.D_WAR = 1` or `CMD_STAT.COMM_ALM = 1 to 7` is detected, a warning occurs but the servo OFF state will not be established. Check the alarm code using the `ALM_RD` command and perform appropriate processing. To clear the warning state, send the `ALM_CLR` command or set `CMD_CTRL.ALM_CLR`.

- For Command Errors

Check the status of `CMD_ALM` with the host controller in every communication cycle and perform appropriate processing because `CMD_ALM` will be automatically cleared on reception of the next normal command after detecting `CMD_STAT.CMD_ALM ≠ 0`.

## 5.9 Notes When the Positioning Completed State (PSET = 1) Is Established While Canceling a Motion Command

When the SERVOPACK enters any of the following states during execution of a motion command, it may cancel the execution of the motion command and establish the positioning completed state (SVCMD\_IO.PSET = 1).

- The servo OFF state (SVCMD\_STAT.SV\_ON = 0) has been established due to an alarm (CMD\_STAT.D\_ALM = 0 or COMM\_ALM ≥ 8).
- The servo OFF state (SVCMD\_STAT.SV\_ON = 0) has been established because the main power supply was turned OFF (SVCMD\_STAT.PON = 0).
- The servo OFF state (SVCMD\_STAT.SV\_ON = 0) has been established because the HWBB signal was turned OFF (SVCMD\_IO.ESTP = 1).
- The motor has stopped due to overtravel (SVCMD\_IO.P-OT or .N-OT = 1) or a software limit (SVCMD\_IO.P\_SOT or .N\_SOT = 1).

In this case, the motor has not reached the target position specified by the host controller even though PSET is set to "1." Check the feedback position (APOS) to confirm that the axis is stopped at a safe position.



Important

If the state of an OT signal varies over a short time (in a pulsing manner for example), the host controller may not be able to monitor the variation of the OT signal properly. Take due care about the selection of limit switches and their mounting and wiring to avoid chattering of OT signals and malfunctioning.



# Function/Command Related Parameters

---

<b>6.1</b>	<b>Position Control</b> .....	<b>155</b>
6.1.1	INTERPOLATE (Interpolating) .....	155
6.1.2	Positioning Command (POSING, FEED, EX_FEED, EX_POSING, ZRET).....	155
<b>6.2</b>	<b>Torque Limiting Function</b> .....	<b>158</b>
6.2.1	Internal Torque Limits.....	158
6.2.2	External Torque Limit Using P_CL/N_CL Bits of SVCMD_IO Field .....	158
6.2.3	Torque Limit by Position/Speed Control Command .....	158
6.2.4	Torque Limit When Torque Limiting Functions Are Combined .....	159
<b>6.3</b>	<b>Torque Feedforward Function</b> .....	<b>160</b>
6.3.1	Relationship between the Host Controller and SERVOPACK.....	160
6.3.2	Setting Parameters .....	161
<b>6.4</b>	<b>Speed Feedforward Function</b> .....	<b>162</b>
6.4.1	Relationship between the Host Controller and SERVOPACK.....	162
6.4.2	Setting Parameters .....	162
<b>6.5</b>	<b>Software Limit Function</b> .....	<b>163</b>
6.5.1	Conditions for Enabling the Software Limit Function .....	163
6.5.2	Parameters Related to Software Limit Functions.....	163
6.5.3	Software Limit Monitoring.....	164
<b>6.6</b>	<b>Latch Function</b> .....	<b>165</b>
6.6.1	Continuous Latch by SVCMD_CTRL.LT_REQ2 .....	166
6.6.2	Setting the Latching Allowable Area .....	168
<b>6.7</b>	<b>Acceleration/Deceleration Parameter High-speed Switching Function</b> .....	<b>170</b>
6.7.1	Specifying a Bank .....	170
6.7.2	Parameter Bank Setting .....	170
6.7.3	Parameters that can Be Registered as Bank Members .....	170
6.7.4	Setting Procedure .....	171
6.7.5	Application Notes.....	172

---

<b>6.8</b>	<b>Triggers at Preset Positions .....</b>	<b>174</b>
6.8.1	Setting Command Data .....	174
6.8.2	Setting Table Parameters List.....	175

## 6.1 Position Control

This section describes the parameters related to interpolation and positioning in position control.

### 6.1.1 INTERPOLATE (Interpolating)

When sending the INTERPOLATE command, the speed feedforward and torque feedforward values can be specified along with the target position.

The sum of the speed feedforward value specified by the INTERPOLATE command and the (speed) feedforward value set in the parameters (common parameter No.64 and Pn10A) will be applied.

Specifying the speed feedforward value using the INTERPOLATE command may lead to overshooting if the settings of the following parameters (common parameter No.64 and Pn10A) are inappropriate. When specifying the speed feedforward value using the INTERPOLATE command, set the parameters to "0" (default setting).

Common Parameters	Name	Data Size (Byte)	Setting Range	Setting Unit	Default Setting
No.64	Feedforward Compensation	4	0 to 100	1%	0

Parameter	Name	Data Size (Byte)	Setting Range	Setting Unit	Default Setting
Pn10A	Feedforward Filter Time Constant	2	0 to 64000	0.01 ms	0

If the speed feedforward and torque feedforward values are specified using the INTERPOLATE command, the values will be cleared when another command is executed.

### 6.1.2 Positioning Command (POSING, FEED, EX\_FEED, EX\_POSING, ZRET)

There are the following two kinds of acceleration/deceleration method for positioning commands (POSING, FEED, EX\_FEED, EX\_POSING, and ZRET).

- Using the acceleration/deceleration specified by the command
- Using the acceleration/deceleration set in the parameters

#### (1) Using the Acceleration/Deceleration (ACCR and DECR) Specified by the Command

When using the acceleration/deceleration (ACCR and DECR) specified by the command, positioning will be performed with 1-step acceleration/deceleration.

When both the acceleration and deceleration (ACCR and DECR) are set to "0" in the command, positioning will be performed with 2-step acceleration/deceleration according to the parameter settings.

#### (2) Using the Acceleration/Deceleration Set in the Parameters

The parameters to set depend on your SERVOPACK as shown below.

SERVOPACK	Parameters to Set
$\Sigma$ -7	The setting of the 1st digit of parameter Pn833 (i.e., Pn833 = n.□□□X) determines which parameter to use for acceleration/deceleration when both the acceleration and deceleration rates (ACCR and DECR) in the command are set to 0.
$\Sigma$ -X	Set both the acceleration and deceleration (ACCR and DECR) for the command to 0 and set the acceleration and deceleration in Pn834 to Pn840.

To use 2-step acceleration/deceleration, set Pn846 to "0". If Pn846 is not "0", only the second stage of acceleration/deceleration will be performed and not the first stage.

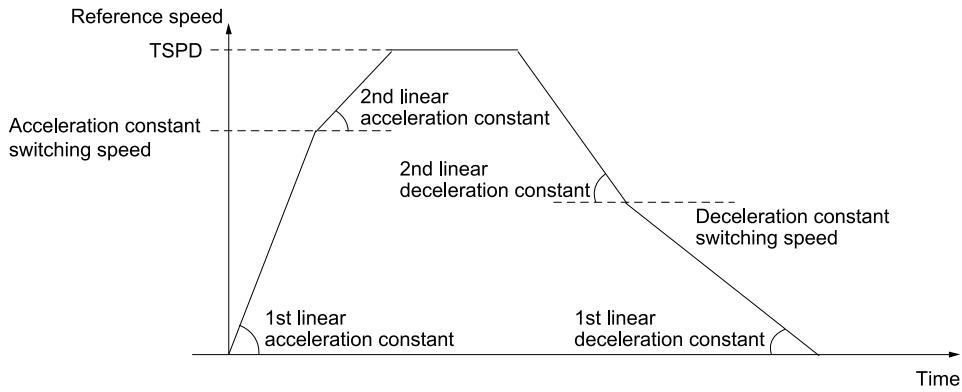

**Note:**

Make settings so that the distance required for deceleration and the deceleration satisfy the following conditions.

$$\text{Deceleration [reference unit/s}^2\text{]} \geq \text{Maximum reference speed [reference unit/s]}^2 / (\text{Maximum deceleration distance [reference unit]} \times 2)$$

Parameter		Meaning	Data Size (Byte)
Pn833	n.□□□0 (Default setting)	Use Pn80A to Pn80F and Pn827. (The settings of Pn834 to Pn840 are ignored.)	2
	n.□□□1	Use Pn834 to Pn840. (The settings of Pn80A to Pn80F and Pn827 are ignored.)	

**Note:**

The setting will be validated by turning the power supply OFF and then ON again, or by executing the CONFIG command.

**(a) Pn80A to Pn80F, Pn827**

Parameter	Name	Data Size (Byte)	Setting Range	Setting Unit	Default Setting
Pn80A	First Stage Linear Acceleration Constant	2	1 to 65535	10000 reference unit/s <sup>2</sup>	100
Pn80B	Second Stage Linear Acceleration Constant	2	1 to 65535	10000 reference unit/s	100
Pn80C	Acceleration Constant Switching Speed	2	0 to 65535	100 reference unit/s <sup>2</sup>	0
Pn80D	First Stage Linear Deceleration Constant	2	1 to 65535	10000 reference unit/s <sup>2</sup>	100
Pn80E	Second Stage Linear Deceleration Constant	2	1 to 65535	10000 reference unit/s <sup>2</sup>	100
Pn80F	Deceleration Constant Switching Speed	2	0 to 65535	100 reference unit/s	0
Pn827	Linear Deceleration Constant for Stopping	2	1 to 65535	10000 reference unit/s <sup>2</sup>	100

**(b) Pn834 to Pn840**

Parameter	Name	Data Size (Byte)	Setting Range	Setting Unit	Default Setting
Pn834	First Stage Linear Acceleration Constant 2	4	1 to 20971520	10000 reference unit/s <sup>2</sup>	100
Pn836	Second Stage Linear Acceleration Constant 2	4	1 to 20971520	10000 reference unit/s <sup>2</sup>	100
Pn838	Acceleration Constant Switching Speed 2	4	0 to 2097152000	1 reference unit/s	0

Continued on next page.

Continued from previous page.

Parameter	Name	Data Size (Byte)	Setting Range	Setting Unit	Default Setting
Pn83A	First Stage Linear Deceleration Constant 2	4	1 to 20971520	10000 reference unit/s <sup>2</sup>	100
Pn83C	Second Stage Linear Deceleration Constant 2	4	1 to 20971520	10000 reference unit/s <sup>2</sup>	100
Pn83E	Deceleration Constant Switching Speed 2	4	0 to 2097152000	1 reference unit/s	0
Pn840	Linear Deceleration Constant 2	4	1 to 20971520	10000 reference unit/s <sup>2</sup>	100

## 6.2 Torque Limiting Function

The torque limiting function limits the torque during position/speed control to protect the connected machine, etc. There are three ways to limit the output torque.

- Internal torque limit according to parameter settings
- External torque limit using the P\_CL and N\_CL bits of the SVCMD\_IO field
- Torque Limit by Position/Speed Control Command

If all of the above three methods are used, the smallest torque limit will be applied. For details, refer to the following section.

 [6.2.4 Torque Limit When Torque Limiting Functions Are Combined on page 159](#)

### 6.2.1 Internal Torque Limits

This method always limits the maximum output torque to the set values of the following parameters.

Parameter	Name	Data Size (Byte)	Setting Range	Setting Unit	Default Setting
Pn402	Forward Torque Limit (For rotational servomotors)	2	0 to 800	1%	800
Pn403	Reverse Torque Limit (For rotational servomotors)	2	0 to 800	1%	800
Pn483	Forward Force Limit (For linear servomotors)	2	0 to 800	1%	30
Pn484	Reverse Force Limit (For linear servomotors)	2	0 to 800	1%	30

### 6.2.2 External Torque Limit Using P\_CL/N\_CL Bits of SVCMD\_IO Field

This method uses SVCMD\_IO.P\_CL and SVCMD\_IO.N\_CL input to limit torque. The torque limits are set with the following parameters. Settings can be made using common parameters.

Common Parameters	Name	Data Size (Byte)	Setting Range	Setting Unit	Default Setting
No.8C	Forward Torque Limit	4	0 to 800	1%	100
No.8D	Reverse Torque Limit	4	0 to 800	1%	100

Parameter	Name	Data Size (Byte)	Setting Range	Setting Unit	Default Setting
Pn404	Forward External Torque Limit	2	0 to 800	1%	100
Pn405	Reverse External Torque Limit	2	0 to 800	1%	100

### 6.2.3 Torque Limit by Position/Speed Control Command

The following position and speed control commands have the TLIM field in the command area.

INTERPOLATE, POSING, FEED, EX\_FEED, EX\_POSING, ZRET, and VELCTRL

When sending the above commands, the torque is limited by the value specified in the TLIM field in the command area.

The torque limits operate based on parameter settings (i.e., Pn002 = n.□□□X). (The torque limit is enabled for the default setting.)

Parameter	Setting	Description	Data Size (Byte)
Pn002	n.□□□0	Reserved (Do not use.)	2
	n.□□□1 (Default Setting)	Forward and reverse torque limits based on the setting of the TLIM field of the position/speed control commands are enabled.	
	n.□□□2	Reserved (Do not use.)	
	n.□□□3	Reserved (Do not use.)	

## 6.2.4 Torque Limit When Torque Limiting Functions Are Combined

If all three types of torque control functions are used, the smallest torque limit will be applied. The following parameters and motion commands set torque limits.

SVCDM_IO	Forward Torque Limit		Reverse Torque Limit	
	SVCDM_IO.P_CL = 0 (Torque not clamped.)	SVCDM_IO.P_CL = 1 (Torque clamped.)	SVCDM_IO.N_CL = 0 (Torque not clamped.)	SVCDM_IO.N_CL = 1 (Torque clamped.)
<b>Parameter or command that can specify torque limit</b>	<ul style="list-style-type: none"> <li>Pn402 (Pn483) <i>*1</i></li> <li>TLIM</li> </ul>	<ul style="list-style-type: none"> <li>Pn402 (Pn483) <i>*1</i></li> <li>Common parameters No.8C</li> <li>TLIM</li> </ul>	<ul style="list-style-type: none"> <li>Pn403 (Pn484) <i>*1</i></li> <li>TLIM</li> </ul>	<ul style="list-style-type: none"> <li>Pn403 (Pn484) <i>*1</i></li> <li>Common parameters No.8D</li> <li>TLIM</li> </ul>

\*1 The parameter numbers in parentheses are for linear servomotors.

When sending a command other than the commands that can specify torque limit, the last torque limit specified by the TLIM field remains valid. During execution of the SV\_OFF or TRQCTRL command, the torque limit specified by the TLIM field becomes invalid and the maximum torque will be used as the limit.

## 6.3 Torque Feedforward Function

The torque feedforward function applies feedforward compensation to position control or speed control to shorten the positioning time. The torque feedforward reference is created from the differential of the position reference at the host controller. Speed feedforward is specified with TFF (speed feedforward) in the position control command.

You can specify speed feedforward for the INTERPOLATE and VELCTR commands.

### 6.3.1 Relationship between the Host Controller and SERVOPACK

The following figures illustrate specifying torque feedforward in commands from the host controller when the SERVOPACK is performing speed control or position control.

#### (1) When SERVOPACK Performs Speed Control

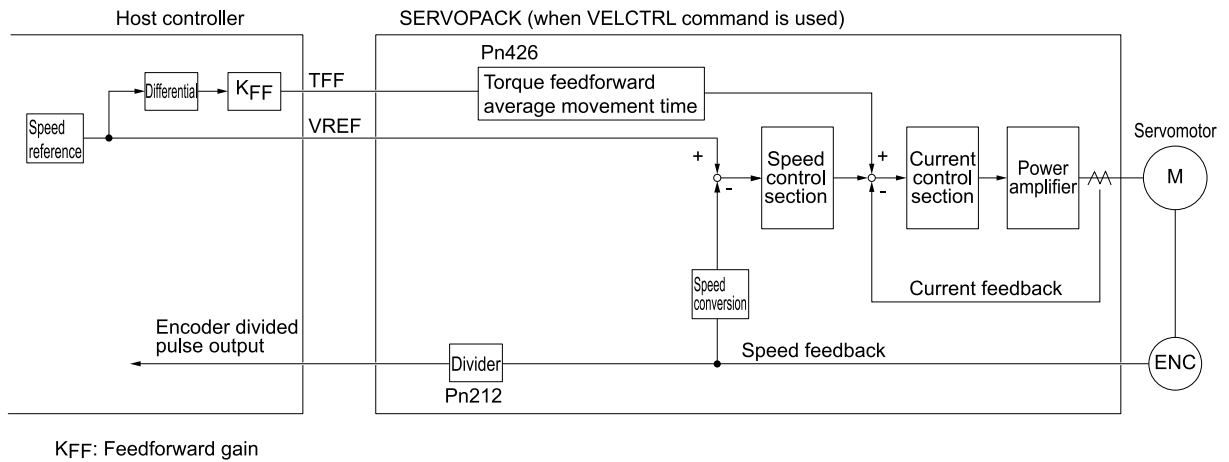

#### (2) When SERVOPACK Performs Position Control

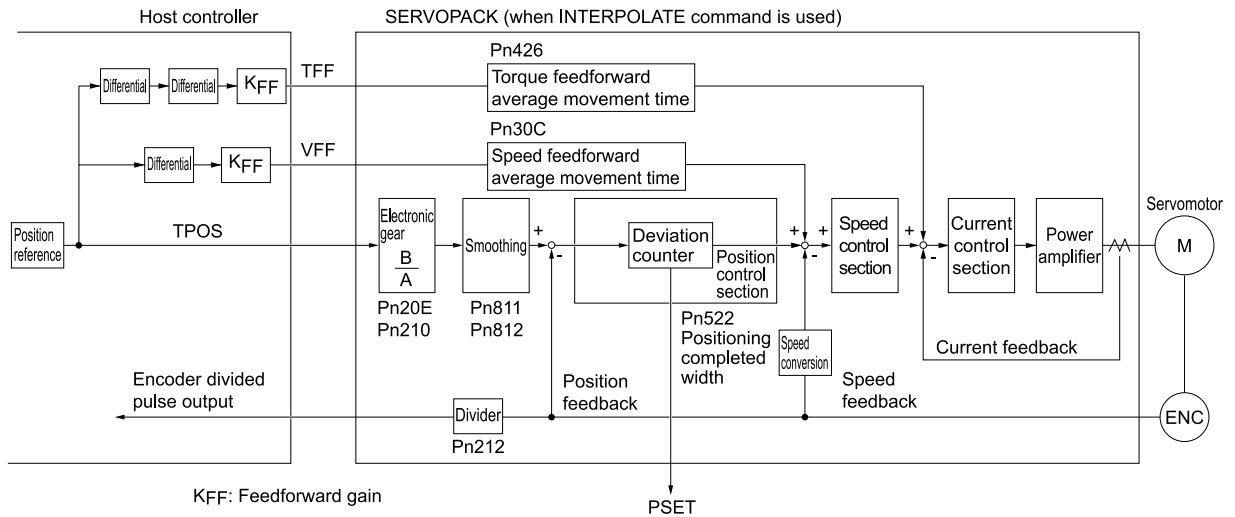

## 6.3.2 Setting Parameters

### (1) Pn426 (Torque Feedforward Average Movement Time)

If the communications cycle with the host controller is slow, the torque feedforward reference may be applied stepwise as shown on the left in the following figure.

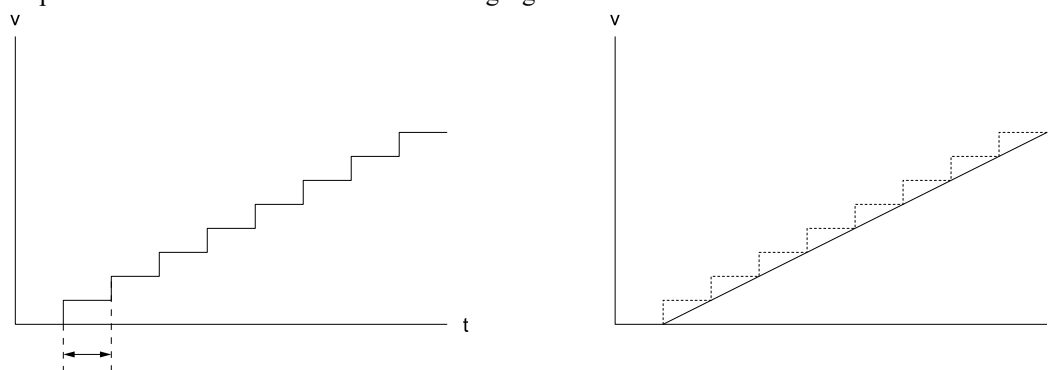

Communications cycle

You can set Pn426 (Torque Feedforward Average Movement Time) to a suitable value to create a smooth torque feedforward reference, as shown on the right in the above figure.

As a guideline, set Pn426 to the same value as the communications cycle.

Parameter	Name	Data Size (Byte)	Setting Range	Setting Unit	Default Setting
Pn426	Torque Feedforward Average Movement Time	2	0 to 5100	0.1 ms	0

## 6.4 Speed Feedforward Function

The speed feedforward function applies feedforward compensation to position control to shorten the positioning time. The speed feedforward reference is created from the differential of the position reference at the host controller. Speed feedforward is specified with VFF (speed feedforward) in the position control command.

You can specify speed feedforward for the INTERPOLATE command.

### 6.4.1 Relationship between the Host Controller and SERVOPACK

The following figure illustrates specifying speed feedforward in a command from the host controller when the SERVOPACK is performing speed control.

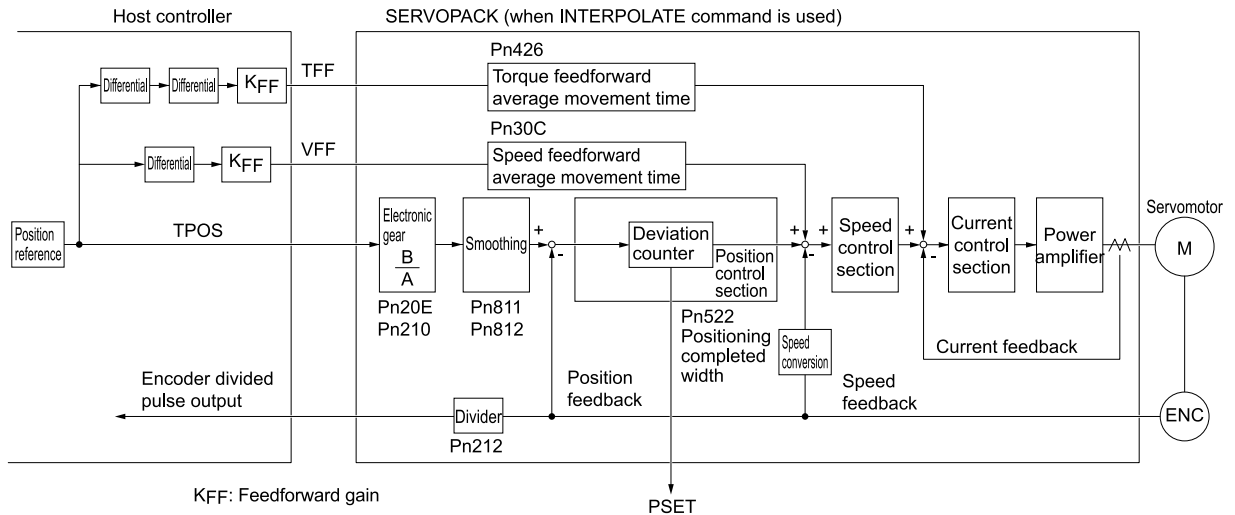

### 6.4.2 Setting Parameters

#### (1) Pn30C (Speed Feedforward Average Movement Time)

If the communications cycle with the host controller is slow, the speed feedforward reference may be applied stepwise as shown on the left in the following figure.

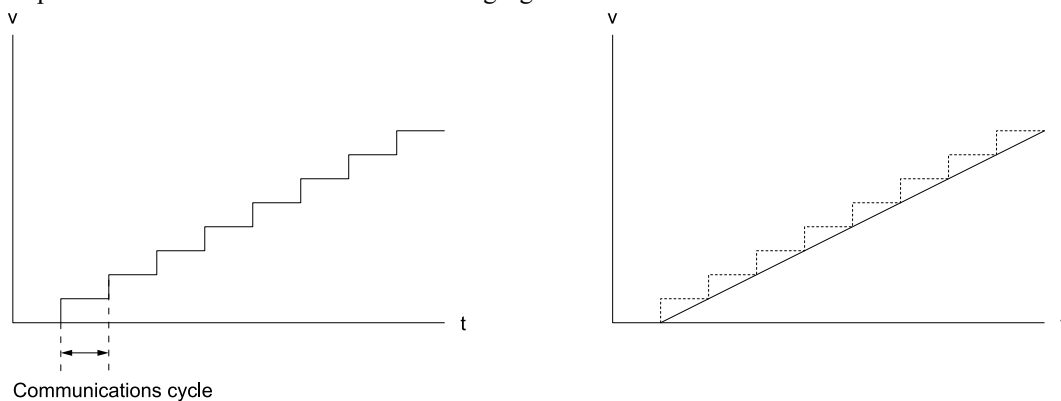

You can set Pn30C (Speed Feedforward Average Movement Time) to a suitable value to create a smooth speed feedforward reference, as shown on the right in the above figure.

As a guideline, set Pn30C to the same value as the communications cycle.

Parameter	Name	Data Size (Byte)	Setting Range	Setting Unit	Default Setting
Pn30C	Speed Feedforward Average Movement Time	2	0 to 5100	0.1 ms	0

## 6.5 Software Limit Function

This function forcibly stops the servomotor in the same way as the overtravel function when the moving part of the machine enters the software limit range specified by the parameters (common parameter No.26, common parameter No.28).

The method for stopping the servomotor is the same as when an OT signal is input.

### 6.5.1 Conditions for Enabling the Software Limit Function

The software limit function is enabled when the following operations are completed. In other cases, the function remains disabled.

- Zero point return operation is completed (ZRET command has completed execution).
- The coordinate setting is completed by setting the reference point (POS\_SET\_MOD.REFE = 1) with the POS\_SET (set coordinates) command.
- When using an absolute encoder, the sensor has completed turning ON (SENS\_ON command has completed execution).

### 6.5.2 Parameters Related to Software Limit Functions

Common Parameters	Name	Data Size (Byte)	Setting Range	Setting Unit	Default Setting	
No.25	Limit Setting		4	0h to 33h	-	0000h
	Bit 0	P-OT (0: Enabled, 1: Disabled)				
	Bit 1	N-OT (0: Enabled, 1: Disabled)				
	Bit 2	Reserved.				
	Bit 3	Reserved.				
	Bit 4	P-SOT (0: Disabled, 1: Enabled)				
	Bit 5	N-SOT (0: Disabled, 1: Enabled)				
Bits 6 to 31	Reserved.					
No.26	Forward Software Limit	4	-1073741823 to 1073741823	1 reference unit	1073741823	
No.28	Reverse Software Limit	4	-1073741823 to 1073741823	1 reference unit	-1073741823	

Parameter		Meaning	Data Size (Byte)	Setting Range	Setting Unit
Pn801	n.□□0	Enable both forward and reverse software limits.	2	0000h to 0103h	-
	n.□□1	Disable forward software limit.			
	n.□□2	Disable reverse software limit.			
	n.□□3 (default setting)	Disable both forward and reverse software limits.			
	n.□□0□ (default setting)	Reserved (Do not change.)			
	n.□0□□ (default setting)	Do not perform software limit checks for references.			
	n.□1□□	Perform software limit checks for references.			
	n.0□□□ (default setting)	Reserved (Do not change.)			
Pn804	Forward Software Limit	4	-1073741823 to 1073741823	1 reference unit	
Pn806	Reverse Software Limit	4	-1073741823 to 1073741823	1 reference unit	

### 6.5.3 Software Limit Monitoring

Check the software limits with SVCMD\_IO.P\_SOT and SVCMD\_IO.N\_SOT.

Software limit operations are not performed in directions for which the software limit function is disabled, and the corresponding servo command input signal monitoring bit is always "0."

- Pn801 = n.□X□□ (Software Limit Check for References)

If the target position specified by a command such as the POSING (positioning) command and the INTERPOLATE (interpolation) command is in the software limit range, positioning will be performed by using the software limit value as the target position.

## 6.6 Latch Function

Three types of current position latch function using an external signal input are available:

- Latching by using the move command with the latch function (EX\_FEED, EX\_POSING, ZRET)
- Latching based on the latch request set by the SVCMD\_CTRL.LT\_REQ1 and SVCMD\_CTRL.LT\_REQ2
- Continuous latch based on the latch request set by the SVCMD\_CTRL.LT\_REQ2

An overview of the latch operation is presented below.

Type Operation	Move Command with Latch Function	Latching Based on the Latch Request Set by the LT_REQ1 and LT_REQ2	Continuous Latch Based on the Latch Request Set by the LT_REQ2
Latch Operation	The SDevice station starts latching on reception of the command if LT_REQ1 = 1, and ends latching on input of the specified latch signal.	The SDevice station starts latching if LT_REQ1 = 1 and LT_REQ2 = 1, and ends latching on input of the specified latch signal.	The SDevice station starts latching if LT_REQ2 = 1, and repeats latching on input of the specified latch signal.
Canceling Latching	Cancelled by LT_REQ1 = 0 Cancelled when the SDevice station receives another command	Cancelled by LT_REQ1 = 0 and LT_REQ2 = 0	Cancelled by LT_REQ2 = 0
Checking Completion of Latching	Check L_CMP1.	Check L_CMP1 and L_CMP2.	Check L_CMP2 and EX_STATUS.
Outputting Latched Position <sup>*1</sup>	LPOS1	LPOS1, 2	LPOS2
Latching Allowable Area	According to the settings of Pn820 and Pn822		

\*1 The specification differs from that of the MECHATROLINK-II compatible profile. Monitor the latched position by selecting the latched position with monitor selection bits SEL\_MON1 to 3.

The relationship among the signals related to latching is shown in the diagram below.

Even if a request for latching is made, latch signals will not be accepted until the latching conditions are satisfied.

Whether the latching conditions have been satisfied or not can be checked at LT\_RDY1 and LT\_RDY2 selected with common monitor 1 (CMN1) and common monitor 2 (CMN2). These monitors correspond to the 0th and 1st bits of the SV\_STAT field of common parameter No.89.

In either of the following cases, latching will not be performed since the latching conditions are not satisfied.

- Outside the latching allowable area set by parameters
- Inside the latching disabled area in the operation sequence for the ZRET command

The operation when latching is completed, the operation when latching is not completed, and the latch time lag are given below.

### • Operation when Latching is Completed

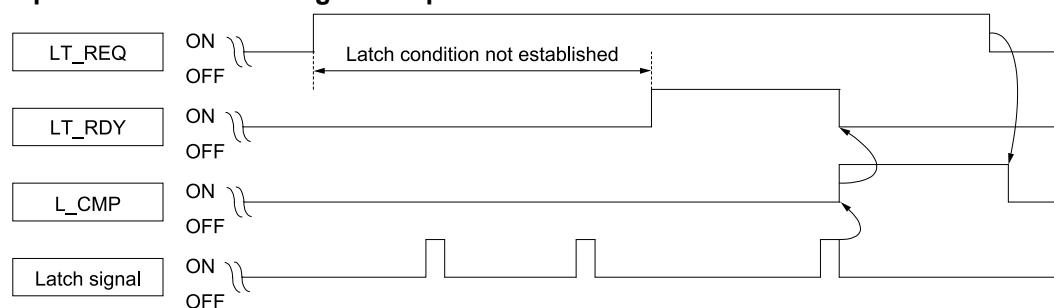

### • Operation when Latching is not Completed

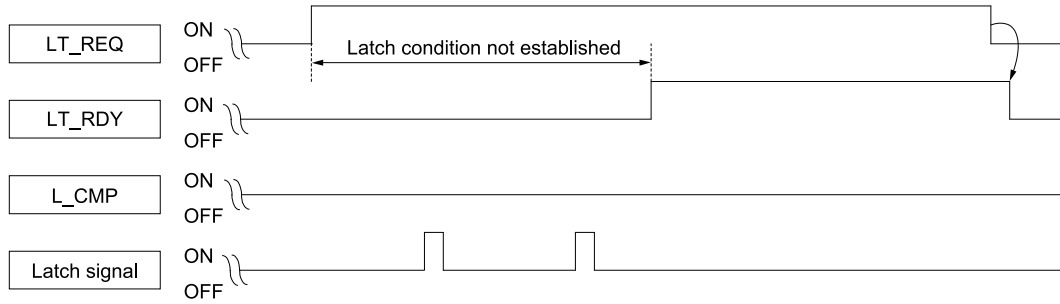

• **Latch Time Lag**

- From reception of the command to latching start: 250 μs max.
- From completion of latching to transmission of a response: One communication cycle max.

### 6.6.1 Continuous Latch by SVCMD\_CTRL.LT\_REQ2

This function sequentially latches the input positions of sequence signal 1 to sequence signal n (n = 1 to 8) a specified number of times. The continuous latch operation can be aborted by setting SVCMD\_CTRL.LT\_REQ2 to "0" (none). This function can shorten the time between latch completion and the start of the next latch, and enables sequential latch operations at high speed.

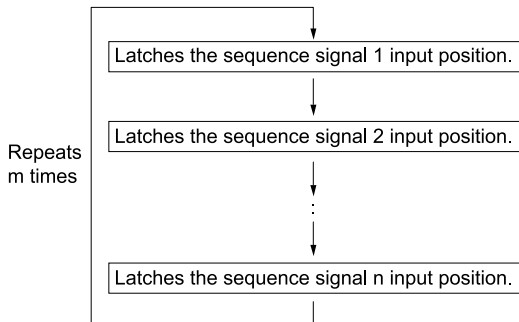

#### (1) How to Start and Stop Continuous Latch Operation

Set the following parameters, and then set SVCMD\_CTRL.LT\_REQ2 to "1" (request for latch) to start continuous latch operation. To abort the operation, set LT\_REQ2 to "0" (none).

Pn850: Number of Latch Sequences n

Pn851: Continuous Latch Sequence Count m (When m = 0, the continuous latch operation will be infinitely repeated.)

Pn852: Latch Sequence 1 to 4 Settings

Pn853: Latch Sequence 5 to 8 Settings

**Note:**

If Pn850 is set to "0" and LT\_REQ2 to "0", normal latching will be performed.

#### (2) Latch Status

Latch completion can be confirmed by the following status.

Status	Description	Field for Checking Status or Setting Method for Checking Status
L_CMP2	L_CMP2 is set to "1" for one communication cycle every time the external signal is input.	Bit 9 of SVCMD_STAT
L_SEQ_NO	The latch sequence signal number ( $\leq n$ ) on completion of latching of the current position (Added on completion of position latching)	Set Pn824 or Pn825 to 0084h to enable EX STATUS to be monitored.
L_CMP_CNT	The continuous latch count ( $\leq m$ ) (Added on completion of position latching when the latch sequence signal n is input.)	This allows L_SEQ_NO to be checked with bits 8 to 11 of the monitor and L_CMP_CNT to be checked with bits 0 to 7 of the monitor.

### (3) Latched Position Data

The latest latched position data at completion of latching can be obtained by using the following monitor.

Name	Code	Remarks
Feedback Latch Position	LPOS2	The latest latch signal input position

Refer to the following section for setting LPOS2.

[2.6.3 Specifying Monitor Data on page 77](#)

The previously latched position data can be obtained by using the following optional monitors.

Name	Code	Remarks
Option Monitor 1	OMN1	Pn824= 0081h: Previous latch (sequence) signal 2 input position (LPOS2)
Option Monitor 2	OMN2	Pn825= 0081h: Previous latch (sequence) signal 2 input position (LPOS2)

### (4) Operation Example

An example of a continuous latch operation using two latch sequence signals (SVCMD\_IO.EXT1 and SVCMD\_IO.EXT2) is illustrated below.

(The parameters are set as follows: Pn850 = 2, Pn851 = 2 or more, Pn852 = 0021h, Pn853 = any)

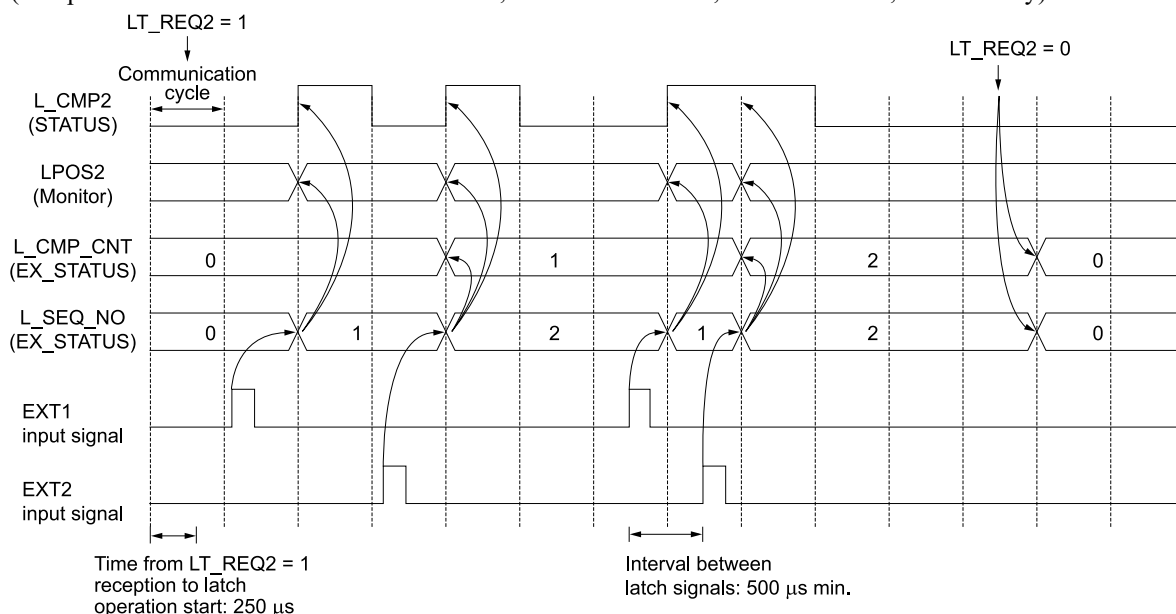

## (5) Setting Parameters

Parameter		Name	Data Size (Byte)	Setting Range	Unit	Default Setting		
No.	Digit							
Pn850		Number of Latch Sequences	2	0 to 8	–	0		
Pn851		Continuous Latch Sequence Count	2	0 to 255	–	0		
Pn852		Latch Sequence 1 to 4 Settings	2	0000h to 3333h	–	0000h		
	n.□□□X	Latch Sequence 1 Signal Selection	0	Phase C	–	0 to 3	–	0
			1	EXT1 signal				
			2	EXT2 signal				
			3	EXT3 signal				
	n.□□X□	Latch Sequence 2 Signal Selection	As above					
	n.□X□□	Latch Sequence 3 Signal Selection	As above					
n.X□□□	Latch Sequence 4 Signal Selection	As above						
Pn853		Latch Sequence 5 to 8 Settings	2	0000h to 3333h	–	0000h		
	n.□□□X	Latch Sequence 5 Signal Selection	0	Phase C	–	0 to 3	–	0
			1	EXT1 signal				
			2	EXT2 signal				
			3	EXT3 signal				
	n.□□X□	Latch Sequence 6 Signal Selection	As above					
	n.□X□□	Latch Sequence 7 Signal Selection	As above					
n.X□□□	Latch Sequence 8 Signal Selection	As above						



Important

- The minimum interval between latch signals is 500 μs. An interval between latch signals that is longer than the communication cycle is required to continuously obtain latched position data.
- If two latch signals are input without allowing the minimum required interval, only the first latch signal input position will be latched. The second latch signal will be ignored.
- The parameters Pn850 to Pn853 can be changed only while the continuous latch operation is stopped.

### 6.6.2 Setting the Latching Allowable Area

Use the following parameters to set the latching allowable area.

Parameter	Name	Data Size (Byte)	Setting Range	Unit	Default Setting
Pn820	Forward Latching Area	4	-2147483648 to 2147483647	1 reference unit	0
Pn822	Reverse Latching Area	4	-2147483648 to 2147483647	1 reference unit	0

Latch signal input is enabled when the following two conditions are satisfied.

- Within the latching allowable area set by Pn820 and Pn822
- The LT\_REQ1 and LT\_REQ2 bits of the SVCMD\_CTRL field are set to "1" (requesting latching). \*

\*1 For the MECHATROLINK-II compatible profile, the conditions are different.

The above conditions for enabling latch signal input are valid for the latch operation for any command.

The latch allowable area when  $Pn820 > Pn822$  is shown below.

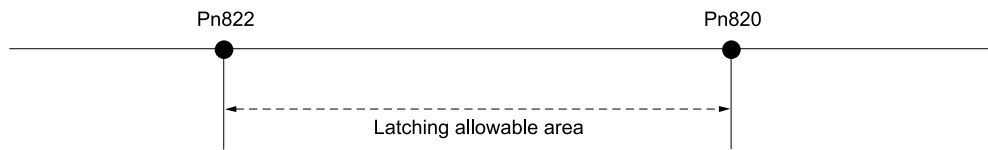

The latch allowable area when  $Pn820 \leq Pn822$  is shown below.



## 6.7 Acceleration/Deceleration Parameter High-speed Switching Function

This function switches all of the acceleration/deceleration parameters that are used for positioning at the same time.

**Information** This function is valid only if you are using a  $\Sigma$ -7 SERVOPACK. You cannot use this function if you are using a  $\Sigma$ -X SERVOPACK.

Register the acceleration/deceleration parameter settings in a bank before starting operation, and specify SVCMD\_IO.BANK\_SEL to switch the acceleration/deceleration parameter settings to those of the registered bank.

### 6.7.1 Specifying a Bank

Specify a bank with the SVCMD\_IO.BANK\_SEL.

Name	Description	Setting Data
BANK_SEL (4 bits)	Bank selector 1 (acceleration/deceleration bank)	Bank 0 to 15

**Note:**

If a bank number larger than the bank number set in Pn900 is specified ( $BANK\_SEL1 \geq Pn900$ ), the parameter bank will not switch and the currently active bank will be used.

The currently active bank will be used. The parameters will not switch while SVCMD\_IO.DEN = 0 (Distributing) either.

### 6.7.2 Parameter Bank Setting

Set the following parameters.

No.	Name	Data Size (Byte)	Setting Range	Default Setting
Pn900	Number of Parameter Banks	2	0 to 16	0
Pn901	Number of Parameter Bank Members	2	0 to 15	0
Pn902 to Pn910	Parameter Bank Member Definition	2	0000h to 08FFh	0
Pn920 to Pn95F <sup>*1</sup>	Parameter Bank Data (Not saved in nonvolatile memory.)	2	0000h to FFFFh Depends on bank member.	0

\*1 The parameters Pn920 to Pn95F will not be stored in the non-volatile memory. They need to be set every time the power is turned ON.

### 6.7.3 Parameters that can Be Registered as Bank Members

The following parameters can be registered as parameter bank members by parameters Pn902 to Pn910.

For 4-byte parameters, one parameter must be registered as two consecutive members. For details, refer to the following section.

 (2) [STEP2 on page 171](#)

Parameter	Name	Data Size (Byte)	Setting Range	Unit	Default Setting
Pn80A	First Stage Linear Acceleration Constant	2	1 to 65535	10000 reference unit/S <sup>2</sup>	100
Pn80B	Second Stage Linear Acceleration Constant	2	1 to 65535	10000 reference unit/s	100
Pn80C	Acceleration Constant Switching Speed	2	0 to 65535	100 reference unit/S <sup>2</sup>	0
Pn80D	First Stage Linear Deceleration Constant	2	1 to 65535	10000 reference unit/S <sup>2</sup>	100
Pn80E	Second Stage Linear Deceleration Constant	2	1 to 65535	10000 reference unit/S <sup>2</sup>	100
Pn80F	Deceleration Constant Switching Speed	2	0 to 65535	100 reference unit/s	0
Pn834	First Stage Linear Acceleration Constant 2	4	1 to 20971520	10000 reference unit/s <sup>2</sup>	100
Pn836	Second Stage Linear Acceleration Constant 2	4	1 to 20971520	10000 reference unit/s <sup>2</sup>	100
Pn838	Acceleration Constant Switching Speed 2	4	0 to 2097152000	1 reference unit/s	0
Pn83A	First Stage Linear Deceleration Constant 2	4	1 to 20971520	10000 reference unit/s <sup>2</sup>	100
Pn83C	Second Stage Linear Deceleration Constant 2	4	1 to 20971520	10000 reference unit/s <sup>2</sup>	100
Pn83E	Deceleration Constant Switching Speed 2	4	0 to 2097152000	1 reference unit/s	0
Pn810	Exponential Acceleration/ Deceleration Bias	2	0 to 65535	100 reference unit/s	0
Pn811	Exponential Acceleration/Deceleration Time Constant	2	0 to 5100	0.1 ms	0
Pn812	Movement Average Time	2	0 to 5100	0.1 ms	0
Pn846	POSING Command S-curve Acceleration/Deceleration Rate	2	0 to 50	1%	0

## 6.7.4 Setting Procedure

### (1) STEP1

1. Set Pn900 (Number of Parameter Banks) to m.
2. Set Pn901 (Number of Parameter Bank Members) to n.  
Set Pn900 and Pn901 so that  $Pn900 \times Pn901 \leq 64$ .
3. Register bank member parameter numbers using parameters Pn902 to Pn910.
4. To enable the bank function, execute the CONFIG command or turn the power supply OFF and then ON again.

### (2) STEP2

Set the data of each bank in order of Pn920 (Parameter Bank Data) as shown below.

Bank 0: Pn920 to Pn (920 + n - 1)

Bank 1: Pn (920 + n) to Pn (920 + 2n - 1)

;

Bank m - 1: Pn {920 + (m - 1) × n} to Pn (920 + m × n - 1)

**Note:**

- If parameters Pn900 to Pn910 set in "(1) STEP1 on page 171" are saved in the non-volatile memory, carry out STEP 2 only after turning the power ON the next and subsequent times.  
However, if you turn the power supply OFF and then ON again after saving parameters Pn900 to Pn910 in the non-volatile memory (i.e. with the bank function enabled), and start the operation without setting parameters Pn920 to Pn95F, the operation will be carried out under the condition that all bank data is set to 0 (zero) or the minimum setting.
- If parameters Pn900 to Pn910 are not saved in the non-volatile memory, carry out "(1) STEP1 on page 171" each time the power supply is turned ON.

- Setting Example 1: Switching three banks of members Pn80B, Pn80E, and Pn80C

Pn900 = 3	Bank number	Pn920 = 80Bh value	Bank 0
Pn901 = 3	Member number	Pn921 = 80Eh value	
		Pn922 = 80Ch value	
Pn902 = 80Bh	Member 1	Pn923 = 80Bh value	Bank 1
Pn903 = 80Eh	Member 2	Pn924 = 80Eh value	
Pn904 = 80Ch	Member 3	Pn925 = 80Ch value	Bank 2
		Pn926 = 80Bh value	
		Pn927 = 80Eh value	
		Pn928 = 80Ch value	

- Setting Example 2: Switching two banks of members Pn836, Pn83C, and Pn838

Pn900 = 2	Bank number	Pn920 = 836h LS word	Bank 0
Pn901 = 6	Member number	Pn921 = 836h MS word	
		Pn922 = 83Ch LS word	
Pn902 = 836h	Member 1	Pn923 = 83Ch MS word	Bank 1
Pn903 = 836h	Member 2	Pn924 = 838h LS word	
Pn904 = 83Ch	Member 3	Pn925 = 838h MS word	
Pn905 = 83Ch	Member 4	Pn926 = 836h LS word	
Pn906 = 838h	Member 5	Pn927 = 836h MS word	
Pn907 = 838h	Member 6	Pn928 = 83Ch LS word	
		Pn929 = 83Ch MS word	
		Pn92A = 838h LS word	
		Pn92B = 838h MS word	

### 6.7.5 Application Notes

- If Pn900 (Number of Parameter Banks) or Pn901 (Number of Parameter Bank Members) is set to 0, the bank function will be disabled.
- If one parameter is registered for more than one bank member definition, the bank data of the biggest bank member definition parameter number will be applied.
- The acceleration/deceleration parameter high-speed switching function is enabled only while SVCMD\_IO.DEN = 1 (distribution completed). The parameters will not switch while SVCMD\_IO.DEN = 0 (distributing). However, this does not apply to Pn846 (POSING Command S-curve Acceleration/Deceleration Rate).
- In the following cases, error A.04A (Parameter Setting Error) will occur when the power supply is turned back ON or CONFIG command is executed.
  - One 4-byte parameter is not registered for two consecutive bank members.
  - The total amount of bank data exceeds 64 ( $Pn900 \times Pn901 > 64$ ).
- If a parameter that is not allowed to be a bank member is registered, the bank data of the parameter-registered member will become invalid.
- Bank data that exceeds the setting range of the registered bank member parameter will be clamped to a value within the setting range.
- If a bank number larger than the bank number set in Pn900 is specified ( $SVCMD\_IO.BANK\_SEL \geq Pn900$ ), the parameter bank will not switch and the currently active bank will be used.

- The parameters Pn920 to Pn95F will not be stored in the non-volatile memory. They need to be set every time the power is turned ON.

## 6.8 Triggers at Preset Positions

Triggers at preset positions are signals that are output when a moving part of a machine passes preset reference positions.

**Information** This function is valid only if you are using a  $\Sigma$ -X SERVOPACK.

For details on the functions, refer to the product manual for your SERVOPACK.

A valid function for  $\Sigma$ -7S SERVOPACKs with FT/EX specifications (model: SGD7S-□□□□□□□□F62), but there are differences in the details of the function. Refer to the following manual instead of this manual if you use a  $\Sigma$ -7 SERVOPACK.

□  $\Sigma$ -7S SERVOPACK with FT/EX Specification for Transfer and Alignment Application Product Manual (Manual No.: SIEP S80001 95)

### 6.8.1 Setting Command Data

Examples of using the MEM\_WR command for triggers at preset positions to write the setting table parameters, saving the settings to non-volatile memory, and initializing related parameters are given below.

#### (1) Example of Setting the Output Position for Output Setting 1 to 100,000

ADDRESS = 0xF0000000

MODE/DATA\_TYPE = 0x13

SIZE = 0x01

DATA = 100000

#### (2) Saving Parameters Related to Outputs at Preset Positions

Use the following procedure to save the settings in RAM to non-volatile memory. Send the commands in the following order.

Step	Description	Setting Example
1	Set the request code for writing to non-volatile memory.	ADDRESS = 0x80004000 MODE/DATA_TYPE = 0x12 SIZE = 0x0001 DATA = 0x2025
2	Execute preparation process 1 for writing to non-volatile memory.	ADDRESS = 0x800041E0 MODE/DATA_TYPE = 0x12 SIZE = 0x0001 DATA = 0x0000
3	Execute preparation process 2 for writing to non-volatile memory.	ADDRESS = 0x800041E4 MODE/DATA_TYPE = 0x13 SIZE = 0x0001 DATA = 0xF0000000
4	Execute preparation process 3 for writing to non-volatile memory.	ADDRESS = 0x80004002 MODE/DATA_TYPE = 0x12 SIZE = 0x0001 DATA = 0x0002
5	Execute the write to non-volatile memory.	ADDRESS = 0x80004002 MODE/DATA_TYPE = 0x12 SIZE = 0x0001 DATA = 0x0001
6	End the write to non-volatile memory.	ADDRESS = 0x80004000 MODE/DATA_TYPE = 0x12 SIZE = 0x0001 DATA = 0x0000

This concludes the procedure to save the related parameters.

### (3) Setting Example to Initialize Related Parameters

Use the following procedure to initialize the settings of the setting table in non-volatile memory to the default values. Refer to the following section for details on the setting table.

 [6.8.2 Setting Table Parameters List on page 175](#)

Send the commands in the following order.

Step	Description	Setting Example
1	Set the request code for initializing nonvolatile memory.	ADDRESS = 0x80004000 MODE/DATA_TYPE = 0x12 SIZE = 0x0001 DATA = 0x2025
2	Execute preparation process 1 for initializing non-volatile memory.	ADDRESS = 0x800041E0 MODE/DATA_TYPE = 0x12 SIZE = 0x0001 DATA = 0x0003
3	Execute preparation process 2 for initializing non-volatile memory.	ADDRESS = 0x800041E4 MODE/DATA_TYPE = 0x13 SIZE = 0x0001 DATA = 0xF0000000
4	Execute preparation process 3 for initializing non-volatile memory.	ADDRESS = 0x80004002 MODE/DATA_TYPE = 0x12 SIZE = 0x0001 DATA = 0x0002
5	Execute the initialization of non-volatile memory.	ADDRESS = 0x80004002 MODE/DATA_TYPE = 0x12 SIZE = 0x0001 DATA = 0x0001
6	End the initialization of non-volatile memory.	ADDRESS = 0x80004000 MODE/DATA_TYPE = 0x12 SIZE = 0x0001 DATA = 0x0000

This concludes the procedure to initialize the parameter settings.

## 6.8.2 Setting Table Parameters List

The following table lists the parameters in the setting table. Use this table to check whether you read or write a parameter when you set a setting table with the MEM\_WR command.

Name	Output Position	Output Function	Output Time	Output Distance	Output Position Compensation	Reserved	Reserved	Reserved
Output Setting 1	0xF0000000	0xF0000004	0xF0000008	0xF000000C	0xF0000010	0xF0000014	0xF0000018	0xF000001C
Output Setting 2	0xF0000020	0xF0000024	0xF0000028	0xF000002C	0xF0000030	0xF0000034	0xF0000038	0xF000003C
Output Setting 3	0xF0000040	0xF0000044	0xF0000048	0xF000004C	0xF0000050	0xF0000054	0xF0000058	0xF000005C
Output Setting 4	0xF0000060	0xF0000064	0xF0000068	0xF000006C	0xF0000070	0xF0000074	0xF0000078	0xF000007C

Continued on next page.

Continued from previous page.

Name	Output Position	Output Function	Output Time	Output Distance	Output Position Compensation	Reserved	Reserved	Reserved
Output Setting 5	0xF0000080	0xF0000084	0xF0000088	0xF000008C	0xF0000090	0xF0000094	0xF0000098	0xF000009C
Output Setting 6	0xF00000A0	0xF00000A4	0xF00000A8	0xF00000AC	0xF00000B0	0xF00000B4	0xF00000B8	0xF00000BC
Output Setting 7	0xF00000C0	0xF00000C4	0xF00000C8	0xF00000CC	0xF00000D0	0xF00000D4	0xF00000D8	0xF00000DC
Output Setting 8	0xF00000E0	0xF00000E4	0xF00000E8	0xF00000EC	0xF00000F0	0xF00000F4	0xF00000F8	0xF00000FC
Output Setting 9	0xF0000100	0xF0000104	0xF0000108	0xF000010C	0xF0000110	0xF0000114	0xF0000118	0xF000011C
Output Setting 10	0xF0000120	0xF0000124	0xF0000128	0xF000012C	0xF0000130	0xF0000134	0xF0000138	0xF000013C
Output Setting 11	0xF0000140	0xF0000144	0xF0000148	0xF000014C	0xF0000150	0xF0000154	0xF0000158	0xF000015C
Output Setting 12	0xF0000160	0xF0000164	0xF0000168	0xF000016C	0xF0000170	0xF0000174	0xF0000178	0xF000017C
Output Setting 13	0xF0000180	0xF0000184	0xF0000188	0xF000018C	0xF0000190	0xF0000194	0xF0000198	0xF000019C
Output Setting 14	0xF00001A0	0xF00001A4	0xF00001A8	0xF00001AC	0xF00001B0	0xF00001B4	0xF00001B8	0xF00001BC
Output Setting 15	0xF00001C0	0xF00001C4	0xF00001C8	0xF00001CC	0xF00001D0	0xF00001D4	0xF00001D8	0xF00001DC
Output Setting 16	0xF00001E0	0xF00001E4	0xF00001E8	0xF00001EC	0xF00001F0	0xF00001F4	0xF00001F8	0xF00001FC
Output Setting 17	0xF0000200	0xF0000204	0xF0000208	0xF000020C	0xF0000210	0xF0000214	0xF0000218	0xF000021C
Output Setting 18	0xF0000220	0xF0000224	0xF0000228	0xF000022C	0xF0000230	0xF0000234	0xF0000238	0xF000023C
Output Setting 19	0xF0000240	0xF0000244	0xF0000248	0xF000024C	0xF0000250	0xF0000254	0xF0000258	0xF000025C
Output Setting 20	0xF0000260	0xF0000264	0xF0000268	0xF000026C	0xF0000270	0xF0000274	0xF0000278	0xF000027C
Output Setting 21	0xF0000280	0xF0000284	0xF0000288	0xF000028C	0xF0000290	0xF0000294	0xF0000298	0xF000029C
Output Setting 22	0xF00002A0	0xF00002A4	0xF00002A8	0xF00002AC	0xF00002B0	0xF00002B4	0xF00002B8	0xF00002BC
Output Setting 23	0xF00002C0	0xF00002C4	0xF00002C8	0xF00002CC	0xF00002D0	0xF00002D4	0xF00002D8	0xF00002DC
Output Setting 24	0xF00002E0	0xF00002E4	0xF00002E8	0xF00002EC	0xF00002F0	0xF00002F4	0xF00002F8	0xF00002FC
Output Setting 25	0xF0000300	0xF0000304	0xF0000308	0xF000030C	0xF0000310	0xF0000314	0xF0000318	0xF000031C
Output Setting 26	0xF0000320	0xF0000324	0xF0000328	0xF000032C	0xF0000330	0xF0000334	0xF0000338	0xF000033C
Output Setting 27	0xF0000340	0xF0000344	0xF0000348	0xF000034C	0xF0000350	0xF0000354	0xF0000358	0xF000035C
Output Setting 28	0xF0000360	0xF0000364	0xF0000368	0xF000036C	0xF0000370	0xF0000374	0xF0000378	0xF000037C
Output Setting 29	0xF0000380	0xF0000384	0xF0000388	0xF000038C	0xF0000390	0xF0000394	0xF0000398	0xF000039C

Continued on next page.

Continued from previous page.

Name	Output Position	Output Function	Output Time	Output Distance	Output Position Compensation	Reserved	Reserved	Reserved
Output Setting 30	0xF00003A0	0xF00003A4	0xF00003A8	0xF00003AC	0xF00003B0	0xF00003B4	0xF00003B8	0xF00003BC
Output Setting 31	0xF00003C0	0xF00003C4	0xF00003C8	0xF00003CC	0xF00003D0	0xF00003D4	0xF00003D8	0xF00003DC
Output Setting 32	0xF00003E0	0xF00003E4	0xF00003E8	0xF00003EC	0xF00003F0	0xF00003F4	0xF00003F8	0xF00003FC



# Detecting Alarms/Warnings Related to Communications or Commands

---

This chapter describes the alarms and warnings that may occur in MECHATROLINK-III communications. For alarms and warnings that are not described in this manual, refer to the product manual for your SERVOPACK.

<b>7.1</b>	<b>Communication Related Alarms .....</b>	<b>180</b>
7.1.1	Communication Errors (CMD_STAT.COMM_ALM) .....	180
7.1.2	Device-Specific Errors (CMD_STAT.D_ALM).....	181
<b>7.2</b>	<b>Warnings Related to Communication and Commands .....</b>	<b>183</b>
7.2.1	Communication Errors (CMD_STAT.COMM_ALM) .....	183
7.2.2	Command Errors (CMD_STAT.CMD_ALM) .....	184
<b>7.3</b>	<b>Monitoring Communication Data on Occurrence of an Alarm or Warning .....</b>	<b>185</b>
7.3.1	$\Sigma$ -X SERVOPACKs .....	185
7.3.2	$\Sigma$ -7 SERVOPACKs .....	185

## 7.1 Communication Related Alarms

The table below shows the communication alarms that may occur in MECHATROLINK-III communications.

If an error is found in the command or data that a SERVOPACK receives, the SERVOPACK returns the corresponding alarm code (CMD\_STAT.COMM\_ALM or CMD\_STAT.D\_ALM).

At the same time, the alarm code is displayed on the SERVOPACK.

### 7.1.1 Communication Errors (CMD\_STAT.COMM\_ALM)

The table below shows the alarms related to procedures in MECHATROLINK-III communications.

If any of these alarms occur, the relevant command will not be executed because the command data is not properly received.

Alarm in Response			Correction	SERVOPACK Side		
COMM_ALM	Name	Meaning		Stopping Method	Alarm Code	Alarm Reset
8	FCS error	FCS errors occurred twice consecutively after completing the execution of the CONNECT command. (Influence of noise, etc.)	Check communication connections. Implement countermeasures against noise. To recover from the alarm state, send the ALM_CLR command and then the SYNC_SET command.	Zero-speed stopping	A.E62	Possible
9	Data Reception Error	Data reception errors occurred twice consecutively after completing the execution of the CONNECT command. (Influence of noise, etc.) An error is detected on the communication LSI.	Check communication connections. Implement countermeasures against noise. To recover from the alarm state, send the ALM_CLR command and then the SYNC_SET command. If the alarm continues, replace the SERVOPACK.	Zero-speed stopping	A.E60	Possible
A	Synchronous Frame Not Received	The synchronous frame not received state was detected twice consecutively after completing the execution of the CONNECT command. (Influence of noise, etc.)	Check communication connections. Implement countermeasures against noise. To recover from the alarm state, send the ALM_CLR command and then the SYNC_SET command.	Zero-speed stopping	A.E63	Possible
B	Transmission Cycle Error	The transmission cycle interval varied after completing the execution of the CONNECT command.	Review the transmission cycle interval of the controller. To recover from the alarm state, send the ALM_CLR command and then the SYNC_SET command.	Zero-speed stopping	A.E61	Possible
C	Synchronization Error	The controller is not refreshing the WDT data in each communication cycle after completing communication synchronization (in communication phase 3).	Review the WDT processing of the controller. To recover from the alarm state, send the ALM_CLR command and then the SYNC_SET command.	Zero-speed stopping	A.E50	Possible
	Synchronization Failure	On reception of the CONNECT command and then the SYNC_SET command, the WDT data is not refreshed in each communication cycle and the communication timing cannot be synchronized.	Review the WDT processing of the controller. Check communication connections. Implement countermeasures against noise.	Zero-speed stopping	A.E51	Possible

---

## 7.1.2 Device-Specific Errors (CMD\_STAT.D\_ALM)

---

The table below shows the device-specific alarms that may occur in MECHATROLINK-III communications. This table contains only device-specific alarms related to MECHATROLINK-III communications. For alarms that are not related to MECHATROLINK-III communications, refer to the product manual for your SERVOPACK.

Alarm in Response			Correction	SERVOPACK Side		
D_ALM	Name	Meaning		Stopping Method	Alarm Code	Alarm Reset
1	Communication data size setting error	The received data size does not match the data size set at the local station. The communication data reception status after starting communication is abnormal.	Review the number of transmission bytes (S3). Review the communication setting of the controller.	Zero-speed stopping	A.E41	Possible
	Station address setting error	The station address setting is invalid or a station assigned the same station address exists in the communication network.	Review the station addresses (S1, S2).	Zero-speed stopping	A.E42	Impossible
	Parameter Setting Error	The parameter settings are not correct when turning the power ON or on execution of the CONFIG command. Cause 1: There is an error in the bank parameter settings. Refer to the following section for details.  <a href="#">6.7 Acceleration/Deceleration Parameter High-speed Switching Function on page 170</a> Cause 2: The settings of the reserved parameters have been changed as follows. Pn200 ≠ n.□1□□ Pn207 ≠ n.□□1□ Pn50A ≠ □881h Pn50C ≠ 8888h Pn50D ≠ 8888h	Correct invalid parameter settings. Correct the settings manually or through communication as appropriate.	Stopping with dynamic brake	A.04A	Possible
	Communication LSI Initialization Error	The initialization process of the communication LSI failed.	Replace the SERVOPACK.	Stopping with dynamic brake	A.b6A	Impossible
	Communication LSI Error	An error is detected on the communication LSI.	Implement countermeasures against noise. Replace the SERVOPACK.	Stopping with dynamic brake	A.b6b	Impossible
	Internal Synchronization Error	The transmission cycle interval varied after completing the execution of the CONNECT command.	Review the transmission cycle interval of the controller. To recover from the alarm state, turn OFF the power and then turn it back ON.	Stopping with dynamic brake	A.E02	Impossible
			Review the transmission cycle interval of the controller. To recover from the alarm state, send the ALM_CLR command and wait for execution to complete, and then send the SYNC_SET command.	Zero-speed stopping	A.EA2	Possible
	Transmission Cycle Setting Error	An unsupported transmission cycle was set on reception of a CONNECT command.	Review the transmission cycle setting of the controller.	Zero-speed stopping	A.E40	Possible
Command Timeout Error	The execution of the SV_ON or SENS_ON command was not completed within the set period.	Send the command while the motor is stopped.	Zero-speed stopping	A.ED1	Possible	

## 7.2 Warnings Related to Communication and Commands

This section describes communications warnings in MECHATROLINK-III communications.

If an error is found in the command or data that a SERVOPACK receives, the SERVOPACK returns the corresponding warning code (CMD\_STAT.COMM\_ALM, or CMD\_STAT.CMD\_ALM).

At the same time, the warning code is displayed on the SERVOPACK.

### 7.2.1 Communication Errors (CMD\_STAT.COMM\_ALM)

The table below shows the warnings related to procedures in MECHATROLINK-III communications.

If any of these warnings occur, the relevant command will not be executed because the command data is not properly received. The operation of the servomotor continues. Therefore, the response will be the same as that of the previous command.

Alarm in Response			SERVOPACK Side	
COMM_ALM	Description	Correction	Warning Code	Warning Code Reset
1	FCS error	Check communication connections. Implement countermeasures against noise.	A.962	Required.
2	Communication error		A.960	
3	Synchronization frame not received		A.963	

If a warning A.96□ occurs during the interpolation operation (INTERPOLATE), the interpolation operation at the current feed speed continues within the communication cycle in which the warning A.96□ was detected.

## 7.2.2 Command Errors (CMD\_STAT.CMD\_ALM)

The table below shows the warnings related to the validity of commands.

Alarm in Response			SERVOPACK Side		Remarks			
CMD_ALM	Description	Correction	Warning Code	Warning Code Reset				
1	The data in the command is beyond the limit. It will be clamped at the limit value.	Review the content of the command data sent by the controller. (Refer to the setting conditions of each command and parameter.)	A.97B	Automatically reset. *1	The command will be executed with the data clamped at the limit value.			
8	An unsupported command has been received.	Review the command sending sequence of the controller. (Refer to the conditions of each command.)	A.95b		Automatically reset. *1	-		
	An illegal command has been received.		A.95F					
9	Parameter numbers or data addresses are incorrect.	Review the content of the command data sent by the controller. (Refer to the setting conditions of each command and parameter.)	A.94A			Automatically reset. *1	The command received on occurrence of the warning will be ignored. The servo-motor continues its operation.	
	The data in the command is invalid.		A.94b					
	The combination of data settings is incorrect.		A.94C					
	The data size specified by the command is incorrect. The data is specified outside the range for the relevant data.		A.94d					
A	The command sequence is incorrect.	Review the command sending sequence of the controller. (Refer to the conditions of each command.)	A.95A				Automatically reset. *1	-
	Latch command interferes.		A.95d					
B	The subcommand and main command interfere with each other.		A.95E					
C	A command not allowed in this communication phase has been received.		A.97A					

\*1 The warning is automatically reset when a normal command is received.

## 7.3 Monitoring Communication Data on Occurrence of an Alarm or Warning

### 7.3.1 $\Sigma$ -X SERVOPACKs

You can monitor the command data that is received when an alarm or warning occurs, such as A.94□ (Data Setting Warning) or A.95□ (Command Warning) with the SigmaWin+.

Monitor				
Operation				
Control	I/F	Item	Unit	SGD7S-1R6A40A Axis#0301
POS SPD TRQ	Common	Temperature margin until Servomotor overheats	°C	48
POS SPD TRQ	Common	Command Data Monitor during Alarm/Warning(0-3byte)	-	H.00003830
POS SPD TRQ	Common	Command Data Monitor during Alarm/Warning(4-7byte)	-	H.00230000
POS SPD TRQ	Common	Command Data Monitor during Alarm/Warning(8-11byte)	-	H.00000000
POS SPD TRQ	Common	Command Data Monitor during Alarm/Warning(12-15byte)	-	H.00000000
POS SPD TRQ	Common	Command Data Monitor during Alarm/Warning(16-19byte)	-	H.00000000
POS SPD TRQ	Common	Command Data Monitor during Alarm/Warning(20-23byte)	-	H.00000000
POS SPD TRQ	Common	Command Data Monitor during Alarm/Warning(24-27byte)	-	H.00000000
POS SPD TRQ	Common	Command Data Monitor during Alarm/Warning(28-31byte)	-	H.00000000
POS SPD TRQ	Common	Command Data Monitor during Alarm/Warning(32-35byte)	-	H.87000030
POS SPD TRQ	Common	Command Data Monitor during Alarm/Warning(36-39byte)	-	H.00000000
POS SPD TRQ	Common	Command Data Monitor during Alarm/Warning(40-43byte)	-	H.00000000

### 7.3.2 $\Sigma$ -7 SERVOPACKs

You can monitor the command data that is received when an alarm or warning occurs, such as a data setting warning (A.94□) or a command warning (A.95□) by using the following parameters. The following is an example of the data when an alarm or warning has occurred in the normal state.

Command Data Monitor during Alarm/Warning: Pn890 to Pn8A6

Response Data Monitor during Alarm/Warning: Pn8A8 to Pn8BE

Command Byte Sequence	Command Data Storage When an Alarm or Warning Occurs	
	CMD	RSP
0	Pn890 = n.□□□□□□XX	Pn8A8 = n.□□□□□□XX
1	Pn890 = n.□□□□XX□□	Pn8A8 = n.□□□□XX□□
2	Pn890 = n.□□XX□□□□	Pn8A8 = n.□□XX□□□□
3	Pn890 = n.XX□□□□□□	Pn8A8 = n.XX□□□□□□
4 to 7	Pn892	Pn8AA
8 to 11	Pn894	Pn8AC
12 to 15	Pn896	Pn8AE
16 to 19	Pn898	Pn8B0
20 to 23	Pn89A	Pn8B2
24 to 27	Pn89C	Pn8B4
28 to 31	Pn89E	Pn8B6
32 to 35	Pn8A0	Pn8B8

Continued on next page.

## 7.3 Monitoring Communication Data on Occurrence of an Alarm or Warning

---

Continued from previous page.

Command Byte Sequence	Command Data Storage When an Alarm or Warning Occurs	
	CMD	RSP
36 to 39	Pn8A2	Pn8BA
40 to 43	Pn8A4	Pn8BC
44 to 47	Pn8A6	Pn8BE

**Note:**

Data is stored in little endian byte order and displayed in the hexadecimal.

# Common Parameters

---

<b>8.1</b>	<b>Overview .....</b>	<b>188</b>
<b>8.2</b>	<b>List of Common Parameters.....</b>	<b>189</b>
<b>8.3</b>	<b>Differences between the Common Parameters.....</b>	<b>200</b>
<b>8.4</b>	<b>Common Parameters and Corresponding Device Parameters .....</b>	<b>202</b>

## 8.1 Overview

Common parameters are assigned common parameter numbers that are defined in the MECHATROLINK-III standard servo profile and are independent of individual devices. The utilization of common parameters means that parameters can be read or set without using parameter numbers or names specific to individual devices.

To read or set common parameters, set the MODE field of the SVPRM\_RD (read servo parameter) command or SVPRM\_WR (write servo parameter) command to 00h (servo parameter type: common parameters).

In the common parameters, there are various parameters that have equivalent functions to device parameters (Pn0□□ to Pn8□□) specific to this SERVOPACK. As shown in the following example, setting either the common parameter or the device parameter will change the value of the corresponding parameter. Refer to the following section for details.

 [8.4 Common Parameters and Corresponding Device Parameters on page 202](#)

The units (number of significant digits) differ between common parameters and device parameters (Pn0□□ to Pn8□□). Therefore, the values are converted between them as shown in the example below so that the device can operate at the accuracy defined with the device parameters.

Changing the position loop gain

Common Parameters		Σ-7/Σ-X Device Parameters
No.63 = 40.000		Pn102 = 40.00
Changed ↓		
No.63 = <u>50.005</u>	→ Converted →	Pn102 = 50.00
		Changed ↓
No.63 = 60.010	← Converted ←	Pn102 = <u>60.01</u>

## 8.2 List of Common Parameters

The following table lists the common MECHATROLINK-III parameters. These common parameters are used to make settings from the host controller via MECHATROLINK communications. Do not change the settings with the digital operator or any other device.

**Information** This section provides information on  $\Sigma$ -XS-series SERVOPACKs. If you are using  $\Sigma$ -XW/ $\Sigma$ -XT/ $\Sigma$ -7S/ $\Sigma$ -7W-series SERVOPACKs, refer to this information together with the information in "8.3 Differences between the Common Parameters on page 200".

### ◆ 01 PnA02: Encoder Type (read only)

Speed Pos Trq

Size	Setting Range	Setting Unit [Resolution]	Default Setting	Applicable Motors	When Enabled
4	0h, 1h	–	–	All	–
Set Value	Meaning				
0000h	Absolute encoder				
0001h	Incremental encoder				

### ◆ 02 PnA04: Motor Type (read only)

Speed Pos Trq

Size	Setting Range	Setting Unit [Resolution]	Default Setting	Applicable Motors	When Enabled
4	0h, 1h	–	–	All	–
Set Value	Meaning				
0000h	Rotary servomotor				
0001h	Linear servomotor				

### ◆ 03 PnA06: Semi-closed/Fully-closed Type (read only)

Speed Pos Trq

Size	Setting Range	Setting Unit [Resolution]	Default Setting	Applicable Motors	When Enabled
4	0h, 1h	–	–	All	–
Set Value	Meaning				
0000h	Semi-closed				
0001h	Fully-closed				

### ◆ 04 PnA08: Rated Speed (read only)

Speed Pos Trq

Size	Setting Range	Setting Unit [Resolution]	Default Setting	Applicable Motors	When Enabled
4	0h to FFFFFFFFh	10 <sup>PnA0C</sup> min <sup>-1</sup>	–	All	–

### ◆ 05 PnA0A: Maximum Output Speed (read only)

Speed Pos Trq

Size	Setting Range	Setting Unit [Resolution]	Default Setting	Applicable Motors	When Enabled
4	0h to FFFFFFFFh	10 <sup>PnA0C</sup> min <sup>-1</sup>	–	All	–

### ◆ 06 PnA0C: Speed Multiplier (read only)

Speed Pos Trq

Size	Setting Range	Setting Unit [Resolution]	Default Setting	Applicable Motors	When Enabled
4	-1073741823 to 1073741823	–	–	All	–

## ◆ 07 PnA0E: Rated Torque (read only)

Speed Pos Trq

Size	Setting Range	Setting Unit [Resolution]	Default Setting	Applicable Motors	When Enabled
4	0h to FFFFFFFFh	10 <sup>PnA12</sup> N·m	–	All	–

## ◆ 08 PnA10: Maximum Output Torque (read only)

Speed Pos Trq

Size	Setting Range	Setting Unit [Resolution]	Default Setting	Applicable Motors	When Enabled
4	0h to FFFFFFFFh	10 <sup>PnA12</sup> N·m	–	All	–

## ◆ 09 PnA12: Torque Multiplier (read only)

Speed Pos Trq

Size	Setting Range	Setting Unit [Resolution]	Default Setting	Applicable Motors	When Enabled
4	-1073741823 to 1073741823	–	–	All	–

## ◆ 0A PnA14: Resolution (read only)

Speed Pos Trq

Size	Setting Range	Setting Unit [Resolution]	Default Setting	Applicable Motors	When Enabled
4	0h to FFFFFFFFh	1 pulse/rev	–	Rotary	–

## ◆ 0B PnA16: Linear Scale Pitch

Speed Pos Trq

Size	Setting Range	Setting Unit [Resolution]	Default Setting	Applicable Motors	When Enabled
4	0 to 65536000	1 nm [0.01 μm]	0	Linear	After restart

## ◆ 0C PnA18: Pulses per Scale Pitch (read only)

Speed Pos Trq

Size	Setting Range	Setting Unit [Resolution]	Default Setting	Applicable Motors	When Enabled
4	0h to FFFFFFFFh	1 pulse/ pitch	–	Linear	–

## ◆ 21 PnA42: Electronic Gear Ratio (Numerator)

Speed Pos Trq

Size	Setting Range	Setting Unit [Resolution]	Default Setting	Applicable Motors	When Enabled
4	1 to 1073741824	–	64	All	After restart

## ◆ 22 PnA44: Electronic Gear Ratio (Denominator)

Speed Pos Trq

Size	Setting Range	Setting Unit [Resolution]	Default Setting	Applicable Motors	When Enabled
4	1 to 1073741824	–	1	All	After restart

## ◆ 23 PnA46: Absolute Encoder Origin Offset

Speed Pos Trq

Size	Setting Range	Setting Unit [Resolution]	Default Setting	Applicable Motors	When Enabled
4	-1073741823 to 1073741823	1 reference unit	0	All	Immediately

**Note:**

The parameter setting is enabled after SENS\_ON command execution is completed.

## ◆ 24 PnA48: Multiturn Limit

Speed Pos Trq

Size	Setting Range	Setting Unit [Resolution]	Default Setting	Applicable Motors	When Enabled
4	0 to 65535	1 Rev	65535	Rotary	After restart

## ◆ 25 PnA4A: Limit Setting

Speed Pos Trq

Size	Setting Range	Setting Unit [Resolution]	Default Setting	Applicable Motors	When Enabled
4	0h to 33h	–	0000h	All	After restart
Bit	Meaning				
Bit 0	P-OT (0: Enabled, 1: Disabled)				
Bit 1	N-OT (0: Enabled, 1: Disabled)				
Bit 2	Reserved.				
Bit 3	Reserved.				
Bit 4	P-SOT (0: Disabled, 1: Enabled)				
Bit 5	N-SOT (0: Disabled, 1: Enabled)				
Bits 6 to 31	Reserved.				

## ◆ 26 PnA4C: Forward Software Limit

Speed Pos Trq

Size	Setting Range	Setting Unit [Resolution]	Default Setting	Applicable Motors	When Enabled
4	-1073741823 to 1073741823	1 reference unit	1073741823	All	Immediately

## ◆ 27 PnA4E: Reserved by System

Speed Pos Trq

Size	Setting Range	Setting Unit [Resolution]	Default Setting	Applicable Motors	When Enabled
4	–	–	0	All	Immediately

## ◆ 28 PnA50: Reverse Software Limit

Speed Pos Trq

Size	Setting Range	Setting Unit [Resolution]	Default Setting	Applicable Motors	When Enabled
4	-1073741823 to 1073741823	1 reference unit	-1073741823	All	Immediately

## ◆ 29 PnA52: Reserved by System

Speed Pos Trq

Size	Setting Range	Setting Unit [Resolution]	Default Setting	Applicable Motors	When Enabled
4	–	–	0	All	Immediately

## ◆ 41 PnA82: Speed Unit

Speed Pos Trq

Size	Setting Range	Setting Unit [Resolution]	Default Setting	Applicable Motors	When Enabled
4	0h to 4h	–	0h	All	After restart
Set Value	Meaning				
0000h	Reference units/s				
0001h	Reference units/min				
0002h	Percentage (%) of rated speed				
0003h	min <sup>-1</sup>				
0004h	Maximum motor speed/40000000h				

**Note:**

- When using fully-closed loop control, set 0000h: reference units/s.
- If you set this parameter to 0002h, adjust the common parameter 42 PnA84 (Speed Base Unit) to satisfy the following formula:  
 $1.28 \times \text{rated speed} [\text{min}^{-1}] \times 10^{\text{PnA84}} < \text{maximum speed} [\text{min}^{-1}]$
- If you set this parameter to either 0002h or 0003h, set the common parameter 42 PnA84 (Speed Base Unit) to a number between -3 and 0.
- If you set this parameter to 0004h, set the common parameter 42 PnA84 (Speed Base Unit) to 0.

◆ 42 PnA84: Speed Base Unit (Set the value of n from the following formula: Speed unit (41 PnA82) × 10<sup>n</sup>.)

Speed Pos Trq

Size	Setting Range	Setting Unit [Resolution]	Default Setting	Applicable Motors	When Enabled
4	-3 to 3	–	0	All	After restart

Note:

- If you set common parameter 41 PnA82 (Speed Unit) to 0002h, set this parameter to satisfy the following formula:  $1.28 \times \text{rated speed} [\text{min}^{-1}] \times 10^{\text{PnA84}} < \text{maximum speed} [\text{min}^{-1}]$
- If you set common parameter 41 PnA82 (Speed Unit) to either 0002h or 0003h, set this parameter to a number between -3 and 0.
- If you set common parameter 41 PnA82 (Speed Unit) to 0004h, set this parameter to 0.

◆ 43 PnA86: Position Unit

Speed Pos Trq

Size	Setting Range	Setting Unit [Resolution]	Default Setting	Applicable Motors	When Enabled
4	0h	–	0h	All	After restart

Set Value	Meaning
0000h	Reference units

◆ 44 PnA88: Position Base Unit (Set the value of n from the following formula: Position unit (43 PnA86) × 10<sup>n</sup>.)

Speed Pos Trq

Size	Setting Range	Setting Unit [Resolution]	Default Setting	Applicable Motors	When Enabled
4	0	–	0	All	After restart

◆ 45 PnA8A: Acceleration Unit

Speed Pos Trq

Size	Setting Range	Setting Unit [Resolution]	Default Setting	Applicable Motors	When Enabled
4	0h	–	0h	All	After restart

Set Value	Meaning
0000h	Reference unit/s <sup>2</sup>

◆ 46 PnA8C: Acceleration Base Unit (Set the value of n from the following formula: Acceleration unit (45 PnA8A) × 10<sup>n</sup>.)

Speed Pos Trq

Size	Setting Range	Setting Unit [Resolution]	Default Setting	Applicable Motors	When Enabled
4	4 to 6	–	4	All	After restart

◆ 47 PnA8E: Torque Unit

Speed Pos Trq

Size	Setting Range	Setting Unit [Resolution]	Default Setting	Applicable Motors	When Enabled
4	1h, 2h	–	1h	All	After restart

Set Value	Meaning
0001h	Percentage (%) of rated torque
0002h	Maximum torque/40000000h

Note:

- If you set this parameter to 0001h, adjust the common parameter 48 PnA90 (Torque Base Unit) to satisfy the following formula:  $128 \times 10^{\text{PnA90}} < \text{maximum torque} [\%]$
- If you set this parameter to 0002h, set the common parameter 48 PnA90 (Torque Base Unit) to 0.

◆ 48 PnA90: Torque Base Unit (Set the value of n from the following formula: Torque unit (47 PnA8E) × 10<sup>n</sup>.)

Speed Pos Trq

Size	Setting Range	Setting Unit [Resolution]	Default Setting	Applicable Motors	When Enabled
4	-5 to 0	–	0	All	After restart

Note:

- If you set common parameter 47 PnA8E (Torque Unit) to 0001h, set this parameter to satisfy the following formula:  
 $128 \times 10^{PnA90} < \text{maximum torque [\%]}$
- If you set common parameter 47 PnA8E (Torque Unit) to 0002h, set this parameter to 0.

◆ 49 PnA92: Supported Unit (read only)

Speed Pos Trq

Size	Setting Range	Setting Unit [Resolution]	Default Setting	Applicable Motors	When Enabled
4	–	–	0601011Fh	All	–

Bit	Meaning
<b>Speed Units</b>	
Bit 0	Reference units/s (1: Enabled)
Bit 1	Reference units/min (1: Enabled)
Bit 2	Percentage (%) of rated speed (1: Enabled)
Bit 3	min <sup>-1</sup> (rpm) (1: Enabled)
Bit 4	Maximum motor speed/4000000h (1: Enabled)
Bits 5 to 7	Reserved (0: Disabled).
<b>Position Units</b>	
Bit 8	Reference units (1: Enabled)
Bits 9 to 15	Reserved (0: Disabled).
<b>Acceleration Units</b>	
Bit 16	Reference unit/s <sup>2</sup> (1: Enabled)
Bit 17	ms (acceleration time required to reach rated speed) (0: Disabled)
Bits 18 to 23	Reserved (0: Disabled).
<b>Torque Units</b>	
Bit 24	N·m (0: Disabled)
Bit 25	Percentage (%) of rated torque (1: Enabled)
Bit 26	Maximum torque/40000000h (1: Enabled)
Bits 27 to 31	Reserved (0: Disabled).

◆ 61 PnAC2: Speed Loop Gain

Speed Pos Trq

Size	Setting Range	Setting Unit [Resolution]	Default Setting	Applicable Motors	When Enabled
4	1000 to 2000000	0.001 Hz [0.1 Hz]	40000	All	Immediately

◆ 62 PnAC4: Speed Loop Integral Time Constant

Speed Pos Trq

Size	Setting Range	Setting Unit [Resolution]	Default Setting	Applicable Motors	When Enabled
4	150 to 512000	1 μs [0.01 ms]	20000	All	Immediately

## ◆ 63 PnAC6: Position Loop Gain

Speed Pos Trq

Size	Setting Range	Setting Unit [Resolution]	Default Setting	Applicable Motors	When Enabled
4	1000 to 2000000	0.001/s [0.1/s]	40000	All	Immediately

## ◆ 64 PnAC8: Feed Forward Compensation

Speed Pos Trq

Size	Setting Range	Setting Unit [Resolution]	Default Setting	Applicable Motors	When Enabled
4	0 to 100	1%	0	All	Immediately

## ◆ 65 PnACA: Position Loop Integral Time Constant

Speed Pos Trq

Size	Setting Range	Setting Unit [Resolution]	Default Setting	Applicable Motors	When Enabled
4	0 to 5000000	1 $\mu$ s [0.1 ms]	0	All	Immediately

## ◆ 66 PnACC: In-position Range

Speed Pos Trq

Size	Setting Range	Setting Unit [Resolution]	Default Setting	Applicable Motors	When Enabled
4	0 to 1073741824	1 reference unit	7	All	Immediately

## ◆ 67 PnACE: Near-position Range

Speed Pos Trq

Size	Setting Range	Setting Unit [Resolution]	Default Setting	Applicable Motors	When Enabled
4	1 to 1073741824	1 reference unit	1073741824	All	Immediately

## ◆ 81 PnB02: Exponential Function Acceleration/Deceleration Time Constant

Speed Pos Trq

Size	Setting Range	Setting Unit [Resolution]	Default Setting	Applicable Motors	When Enabled
4	0 to 510000	1 $\mu$ s [0.1 ms]	0	All	Immediately

**Note:**

Change the setting when the reference is stopped (while DEN is set to 1). If you change the setting during operation, the reference output will be affected.

## ◆ 82 PnB04: Movement Average Time

Speed Pos Trq

Size	Setting Range	Setting Unit [Resolution]	Default Setting	Applicable Motors	When Enabled
4	0 to 510000	1 $\mu$ s [0.1 ms]	0	All	Immediately

**Note:**

Change the setting when the reference is stopped (while DEN is set to 1). If you change the setting during operation, the reference output will be affected.

## ◆ 83 PnB06: Final Travel for External Input Positioning

Speed Pos Trq

Size	Setting Range	Setting Unit [Resolution]	Default Setting	Applicable Motors	When Enabled
4	-1073741823 to 1073741823	1 reference unit	100	All	Immediately

## ◆ 84 PnB08: Zero Point Return Approach Speed

Speed Pos Trq

Size	Setting Range	Setting Unit [Resolution]	Default Setting	Applicable Motors	When Enabled
4	0h to 3FFFFFFh	$10^{-3}$ min <sup>-1</sup>	$\times$ 5000h reference units/s converted to $10^{-3}$ min <sup>-1</sup>	All	Immediately

## ◆ 85 PnB0A: Zero Point Return Creep Speed

Speed Pos Trq

Size	Setting Range	Setting Unit [Resolution]	Default Setting	Applicable Motors	When Enabled
4	0h to 3FFFFFFh	10 <sup>-3</sup> min <sup>-1</sup>	× 500h reference units/s converted to 10 <sup>-3</sup> min <sup>-1</sup>	All	Immediately

## ◆ 86 PnB0C: Final Travel for Zero Point Return

Speed Pos Trq

Size	Setting Range	Setting Unit [Resolution]	Default Setting	Applicable Motors	When Enabled
4	-1073741823 to 1073741823	1 reference unit	100	All	Immediately

## ◆ 87 PnB0E: Monitor Select 1

Speed Pos Trq

Size	Setting Range	Setting Unit [Resolution]	Default Setting	Applicable Motors	When Enabled
4	0000h to FFFFh	–	0001h	All	Immediately

Set Value	Meaning
0000h	APOS
0001h Default	CPOS
0002h	PERR
0003h	LPOS1
0004h	LPOS2
0005h	FSPD
0006h	CSPD
0007h	TRQ
0008h	ALARM
0009h	MPOS
000Ah	Reserved (undefined value).
000Bh	Reserved (undefined value).
000Ch	CMN1 (common monitor 1)
000Dh	CMN2 (common monitor 2)
000Eh	OMN1 (optional monitor 1)
000Fh	OMN2 (optional monitor 2)
Other values	Reserved (Do not use.)

## ◆ 88 PnB10: Monitor Select 2

Speed Pos Trq

Size	Setting Range	Setting Unit [Resolution]	Default Setting	Applicable Motors	When Enabled
4	0000h to FFFFh	–	0000h	All	Immediately

Set Value	Meaning
0000h to FFFFh	The settings are the same as those for Monitor Select 1.

◆ 89 PnB12: Monitor Select for SEL\_MON1 (CMN1)

Speed Pos Trq

Size	Setting Range	Setting Unit [Resolution]	Default Setting	Applicable Motors	When Enabled
4	0h to Ah	–	0h	All	Immediately
Set Value	Meaning				
0000h	TPOS (target position in reference coordinate system)				
0001h	IPOS (reference position in reference coordinate system)				
0002h	POS_OFFSET (offset set in POS_SET (Set Coordinate System) command)				
0003h	TSPD (target speed)				
0004h	SPD_LIM (speed limit)				
0005h	TRQ_LIM (torque limit)				
0006h	SV_STAT (servo actual operating status) Monitor Description <ul style="list-style-type: none"> <li>• Byte 1: Current communications phase                             <ul style="list-style-type: none"> <li>– 00h: Phase 0</li> <li>– 01h: Phase 1</li> <li>– 02h: Phase 2</li> <li>– 03h: Phase 3</li> </ul> </li> <li>• Byte 2: Current control mode                             <ul style="list-style-type: none"> <li>– 00h: Position control mode</li> <li>– 01h: Speed control mode</li> <li>– 02h: Torque control mode</li> </ul> </li> <li>• Byte 3: Reserved</li> <li>• Byte 4: Expansion signal monitor                             <ul style="list-style-type: none"> <li>– Bit 0: LT_RDY1: Processing status for latch detection for LT_REQ1 in SVCMD_CTRL region (0: Latch detection not yet processed. 1: Processing latch detection in progress.)</li> <li>– Bit 1: LT_RDY2: Processing status for latch detection for LT_REQ2 in SVCMD_CTRL region (0: Latch detection not yet processed. 1: Processing latch detection in progress.)</li> <li>– Bits 2 and 3: LT_SEL1R: Latch signal (0: Phase C, 1: External input signal 1, 2: External input signal 2, external input signal 3)</li> <li>– Bits 4 and 5: LT_SEL2R: Latch signal (0: Phase C, 1: External input signal 1, 2: External input signal 2, external input signal 3)</li> <li>– Bit 6: Reserved (0).</li> </ul> </li> </ul>				
0007h	Reserved.				
0008h	INIT_PGPOS (Low) Lower 32 bits of initial encoder position converted to 64-bit position reference data				
0009h	INIT_PGPOS (High) Upper 32 bits of initial encoder position converted to 64-bit position reference data				
000Ah	Reserved.				

◆ 8A PnB14: Monitor Select for SEL\_MON2 (CMN2)

Speed Pos Trq

Size	Setting Range	Setting Unit [Resolution]	Default Setting	Applicable Motors	When Enabled
4	0h to Ah	–	0h	All	Immediately
Set Value	Meaning				
0000h to 000Ah	The settings are the same as those for SEL_MON Monitor Selection 1.				

## ◆ 8B PnB16: Zero Point Detection Range

Speed Pos Trq

Size	Setting Range	Setting Unit [Resolution]	Default Setting	Applicable Motors	When Enabled
4	0 to 250	1 reference unit	10	All	Immediately

## ◆ 8C PnB18: Forward Torque Limit

Speed Pos Trq

Size	Setting Range	Setting Unit [Resolution]	Default Setting	Applicable Motors	When Enabled
4	0 to 800	1%	100	All	Immediately

## ◆ 8D PnB1A: Reverse Torque Limit

Speed Pos Trq

Size	Setting Range	Setting Unit [Resolution]	Default Setting	Applicable Motors	When Enabled
4	0 to 800	1%	100	All	Immediately

## ◆ 8E PnB1C: Zero Speed Detection Range

Speed Pos Trq

Size	Setting Range	Setting Unit [Resolution]	Default Setting	Applicable Motors	When Enabled
4	1000 to 10000000	10 <sup>-3</sup> min <sup>-1</sup>	20000	All	Immediately

## ◆ 8F PnB1E: Speed Match Signal Detection Range

Speed Pos Trq

Size	Setting Range	Setting Unit [Resolution]	Default Setting	Applicable Motors	When Enabled
4	0 to 100000	10 <sup>-3</sup> min <sup>-1</sup>	10000	All	Immediately

## ◆ 90 PnB20: SVCMD\_CTRL bit Enabled/Disabled (read only)

Speed Pos Trq

Size	Setting Range	Setting Unit [Resolution]	Default Setting	Applicable Motors	When Enabled
4	–	–	0FFF3F3Fh	All	–

Bit	Meaning
Bit 0	CMD_PAUSE (1: Enabled)
Bit 1	CMD_CANCEL (1: Enabled)
Bits 2, 3	STOP_MODE (1: Enabled)
Bits 4, 5	ACCFIL (1: Enabled)
Bits 6, 7	Reserved (0: Disabled).
Bit 8	LT_REQ1 (1: Enabled)
Bit 9	LT_REQ2 (1: Enabled)
Bits 10, 11	LT_SEL1 (1: Enabled)
Bits 12, 13	LT_SEL2 (1: Enabled)
Bits 14, 15	Reserved (0: Disabled).
Bits 16 to 19	SEL_MON1 (1: Enabled)
Bits 20 to 23	SEL_MON2 (1: Enabled)
Bits 24 to 27	SEL_MON3 (1: Enabled)
Bits 28 to 31	Reserved (0: Disabled).

## ◆ 91 PnB22: SVCMD\_STAT bit Enabled/Disabled (read only)

Speed Pos Trq

Size	Setting Range	Setting Unit [Resolution]	Default Setting	Applicable Motors	When Enabled
4	–	–	0FFF3F33h	All	–
Bit	Meaning				
Bit 0	CMD_PAUSE_CMP (1: Enabled)				
Bit 1	CMD_CANCEL_CMP (1: Enabled)				
Bits 2, 3	Reserved (0: Disabled).				
Bits 4, 5	ACCFIL (1: Enabled)				
Bits 6, 7	Reserved (0: Disabled).				
Bit 8	L_CMP1 (1: Enabled)				
Bit 9	L_CMP2 (1: Enabled)				
Bit 10	POS_RDY (1: Enabled)				
Bit 11	PON (1: Enabled)				
Bit 12	M_RDY (1: Enabled)				
Bit 13	SV_ON (1: Enabled)				
Bits 14, 15	Reserved (0: Disabled).				
Bits 16 to 19	SEL_MON1 (1: Enabled)				
Bits 20 to 23	SEL_MON2 (1: Enabled)				
Bits 24 to 27	SEL_MON3 (1: Enabled)				
Bits 28 to 31	Reserved (0: Disabled).				

## ◆ 92 PnB24: I/O Bit Enabled/Disabled (Output) (read only)

Speed Pos Trq

Size	Setting Range	Setting Unit [Resolution]	Default Setting	Applicable Motors	When Enabled
4	–	–	88FF01F0h 897F01F0h	All	–
Bit	Meaning				
Bits 0 to 3	Reserved (0: Disabled).				
Bit 4	V_PPI (1: Enabled)				
Bit 5	P_PPI (1: Enabled)				
Bit 6	P_CL (1: Enabled)				
Bit 7	N_CL (1: Enabled)				
Bit 8	G_SEL (1: Enabled)				
Bits 9 to 11	G_SEL (0: Disabled)				
Bits 12 to 15	Reserved (0: Disabled).				
Bits 16 to 19	BANK_SEL (1: Enabled)				
Bits 20 to 22	SO1 to SO3 (1: Enabled)				
Bits 23 to 30	Reserved (0: Disabled).				
Bits 20 to 24	SO1 to SO5 (1: Enabled)				
Bits 25 to 30	Reserved (0: Disabled).				
Bit 31	EXT_TRC (1: Enabled)				

## ◆ 93 PnB26: I/O Bit Enabled/Disabled (Input) (read only)

Speed Pos Trq

Size	Setting Range	Setting Unit [Resolution]	Default Setting	Applicable Motors	When Enabled
4	–	–	FF0FFFEh	All	–
Bit	Meaning				
Bit 0	Reserved (0: Disabled).				
Bit 1	DEC (1: Enabled)				
Bit 2	P-OT (1: Enabled)				
Bit 3	N-OT (1: Enabled)				
Bit 4	EXT1 (1: Enabled)				
Bit 5	EXT2 (1: Enabled)				
Bit 6	EXT3 (1: Enabled)				
Bit 7	ESTP (1: Enabled)				
Bit 8	Reserved (0: Disabled).				
Bit 9	BRK_ON (1: Enabled)				
Bit 10	P-SOT (1: Enabled)				
Bit 11	N-SOT (1: Enabled)				
Bit 12	DEN (1: Enabled)				
Bit 13	NEAR (1: Enabled)				
Bit 14	PSET (1: Enabled)				
Bit 15	ZPOINT (1: Enabled)				
Bit 16	T_LIM (1: Enabled)				
Bit 17	V_LIM (1: Enabled)				
Bit 18	V_CMP (1: Enabled)				
Bit 19	ZSPD (1: Enabled)				
Bits 20 to 23	Reserved (0: Disabled).				
Bits 24 to 31	IO_STS1 to IO_STS8 (1: Enabled)				

## 8.3 Differences between the Common Parameters

The following table lists the differences between the common parameters of  $\Sigma$ -XS-series SERVOPACKs and  $\Sigma$ -XW/ $\Sigma$ -XT/ $\Sigma$ -7S/ $\Sigma$ -7W-series SERVOPACKs.

"8.2 List of Common Parameters on page 189" provides information on  $\Sigma$ -XS-series SERVOPACKs. If you are using  $\Sigma$ -XW/ $\Sigma$ -XT/ $\Sigma$ -7S/ $\Sigma$ -7W-series SERVOPACKs, refer to this information together with the information in "8.2 List of Common Parameters on page 189".

Parameter No.	Location of Difference	Details of Difference				
		$\Sigma$ -XS SERVOPACK	$\Sigma$ -XW SERVOPACK	$\Sigma$ -XT SERVOPACK	$\Sigma$ -7S SERVOPACK	$\Sigma$ -7W SERVOPACK
21 PnA42	Default Setting	64			16	
87 PnB0E	Set value: 009Dh (Un173: Temperature Margin until SERVOPACK Overheats)	Settable			Not settable	
87 PnB0E	Set value: 00A8h (Un13C: Margin until Regenerative Overload)	Settable			Not settable	
87 PnB0E	Set value: 00AAh (Un13E: Margin until Undervoltage)	Settable			Not settable	
87 PnB0E	Set value: 00ABh (Un13F: Margin until Overvoltage)	Settable			Not settable	
87 PnB0E	Set value: 00B0h (Un023: Main Circuit DC Voltage)	Settable			Not settable	
87 PnB0E	Set value: 00CCh (Un07C: Identified Moment of Inertia Ratio)	Settable			Not settable	
87 PnB0E	Set value: 00CEh (Un108: Maximum Settling Time)	Settable			Not settable	
87 PnB0E	Set value: 00CFh (Un109: Maximum Amount of Overshoot)	Settable			Not settable	
87 PnB0E	Set value: 0154h (Un177: Encoder Power Supplied Time)	Settable			Not settable	
87 PnB0E	Set value: 0156h (Un17A: Encoder Power Supply Voltage)	Settable			Not settable	
87 PnB0E	Set value: 0157h (Un17B: Encoder Battery Voltage)	Settable			Not settable	
87 PnB0E	Set value: 015Ch (Un181: Motor Total Number of Rotations)	Settable			Not settable	
87 PnB0E	Set value: 015Dh (Un183: Maintenance Prediction Monitor - Bearings)	Settable			Not settable	

Continued on next page.

Continued from previous page.

Parameter No.	Location of Difference	Details of Difference				
		$\Sigma$ -XS SERVOPACK	$\Sigma$ -XW SERVOPACK	$\Sigma$ -XT SERVOPACK	$\Sigma$ -7S SERVOPACK	$\Sigma$ -7W SERVOPACK
87 PnB0E	Set value: 015Eh (Un184: Maintenance Prediction Monitor - Oil Seal)	Settable			Not settable	
87 PnB0E	Set value: 0163h (File upload counter)	Settable			Not settable	
87 PnB0E	Set value: 0164h (File upload data)	Settable			Not settable	
87 PnB0E	Set value: 0165h (Error detection trace counter)	Settable			Not settable	
87 PnB0E	Set value: 0166h (Error detection trace error rate)	Settable			Not settable	
87 PnB0E	Set value: 0176h (Un190: Motor Vibration in X-Axis Direction)	Settable			Not settable	
87 PnB0E	Set value: 0177h (Un191: Motor Vibration in Y-Axis Direction)	Settable			Not settable	
87 PnB0E	Set value: 0178h (Un192: Motor Vibration in Z-Axis Direction)	Settable			Not settable	
87 PnB0E	Set value: 0179h (Un193: Motor Vibration XYZ Composite Value)	Settable			Not settable	
87 PnB0E	Set value: 017Ah (Un194: Maximum Motor Vibration)	Settable			Not settable	
87 PnB0E	Set value: 0250h to 0257h ( $\Sigma$ -LINK II Response Data 1 to 8)	Settable			Not settable (The $\Sigma$ -LINK II function is not supported.)	
87 PnB0E	Set value: 0260h to 0263h ( $\Sigma$ -LINK II Command Data 1 to 4)	Settable			Not settable (The $\Sigma$ -LINK II function is not supported.)	
87 PnB0E	Set value: 0290h ( $\Sigma$ -LINK II Data Status Information)	Settable			Not settable (The $\Sigma$ -LINK II function is not supported.)	
88 PnB10	Same as 87 PnB0E					
92 PnB24	Default setting	807F01F0h	81FF01F0h	897F01F0h	007F01F0h	01FF01F0h
	Bits 20 to 31:	<ul style="list-style-type: none"> <li>• Bits 20 to 22: SO1 to SO3</li> <li>• Bits 23 to 30: Reserved.</li> <li>• Bit 31: EXT_TRC</li> </ul>	<ul style="list-style-type: none"> <li>• Bits 20 to 24: SO1 to SO5</li> <li>• Bits 25 to 30: Reserved.</li> <li>• Bit 31: EXT_TRC</li> </ul>		<ul style="list-style-type: none"> <li>• Bits 20 to 22: SO1 to SO3</li> <li>• Bits 23 to 31: Reserved.</li> </ul>	<ul style="list-style-type: none"> <li>• Bits 20 to 24: SO1 to SO5</li> <li>• Bits 25 to 31: Reserved.</li> </ul>

## 8.4 Common Parameters and Corresponding Device Parameters

Category	Common Parameters	Meaning	Corresponding Device Parameter	Remarks
Device Information Related Parameters	01	Encoder Type	–	–
	02	Motor Type	–	–
	03	Semi-Closed/Fully-Closed Type	–	–
	04	Rated Speed	–	–
	05	Maximum Output Speed	–	–
	06	Speed Multiplier	–	–
	07	Rated Torque	–	–
	08	Maximum Output Torque	–	–
	09	Torque Multiplier	–	–
	0A	Resolution (Rotary)	–	–
	0B	Scale Pitch (Linear)	–	–
	0C	Pulses per Scale Pitch (Linear)	–	–
Machine Specification Related Parameters	21	Electronic Gear Ratio (Numerator)	Pn20E	–
	22	Electronic Gear Ratio (Denominator)	Pn210	–
	23	Absolute Encoder Origin Offset	Pn808	–
	24	Multiturn Limit Setting	Pn205	–
	25	Limit Setting	Pn50A Pn50B Pn801	–
	26	Forward Software Limit	Pn804	–
	27	Reserved by System	–	–
	28	Reverse Software Limit	Pn806	–
	29	Reserved by System	–	–
Unit System Related Parameters	41	Speed Unit	–	–
	42	Speed Base Unit	–	–
	43	Position Unit	–	–
	44	Position Base Unit	–	–
	45	Acceleration Unit	–	–
	46	Acceleration Base Unit	–	–
	47	Torque Unit	–	–
	48	Torque Base Unit	–	–
Adjustment Related Parameters	61	Speed Loop Gain	Pn100	–
	62	Speed Loop Integral Time Constant	Pn101	–
	63	Position Loop Gain	Pn102	–
	64	Feedforward Compensation	Pn109	–
	65	Position Loop Integral Time Constant	Pn11F	–
	66	Positioning Completed Width	Pn522	–
	67	Near Signal Width	Pn524	–

Continued on next page.

Continued from previous page.

Category	Common Parameters	Meaning	Corresponding Device Parameter	Remarks
Command Related Parameters	81	Exponential Acceleration/Deceleration Time Constant	Pn811	–
	82	Movement Average Time	Pn812	–
	83	External Positioning Final Travel Distance	Pn814	EX_POSING EX_FEED
	84 *1	Zero Point Return Approach Speed	Pn817 or Pn842	ZRET
	85 *2	Zero Point Return Creep Speed	Pn818 or Pn844	ZRET
	86	Final Travel Distance for Origin Return	Pn819	ZRET
	87	Monitor Selection 1	–	–
	88	Monitor Selection 2	–	–
	89	Monitor Select for SEL_MON1	–	–
	8A	Monitor Select for SEL_MON2	–	–
	8B	Origin Detection Range	Pn803	–
	8C	Forward Torque Limit	Pn404	–
	8D	Reverse Torque Limit	Pn405	–
	8E	Zero Speed Detection Range	Rotary servomotor: Pn502 Linear servomotor: Pn581	–
	8F	Speed Coincidence Signal Detection Width	Rotary servomotor: Pn503 Linear servomotor: Pn582	–
	90	Servo Command Control Field Enabled/Disabled	–	–
	91	Servo Command Status Field Enabled/Disabled	–	–
	92	I/O Bit Enabled/Disabled (Output)	–	–
93	I/O Bit Enabled/Disabled (Input)	–	–	

\*1 The common parameter 84 is linked with Pn817 or Pn824. At factory setting, the value of Pn817 is effective. When Pn817 is set to zero or a value outside the allowable range, the value of Pn842 will become effective. After the value of Pn842 become effective, the value stays effective even if the value of Pn817 within the allowable range is set to parameter 84.

\*2 The common parameter 85 is linked with Pn818 or Pn844. At factory setting, the value of Pn818 is effective. When Pn818 is set to zero or a value outside the allowable range, the value of Pn844 will become effective. After the value of Pn844 become effective, the value stays effective even if the value of Pn818 within the allowable range is set to parameter 85.



# Virtual Memory Space

---

<b>9.1</b>	<b>Virtual Memory Space .....</b>	<b>206</b>
9.1.1	$\Sigma$ -7S/ $\Sigma$ -XS SERVOPACKs .....	206
9.1.2	$\Sigma$ -7W/ $\Sigma$ -XW SERVOPACKs .....	207
9.1.3	$\Sigma$ -XT SERVOPACKs .....	207
<b>9.2</b>	<b>Information Allocated to Virtual Memory .....</b>	<b>209</b>
9.2.1	ID Information Area .....	209
9.2.2	Common Parameter Area .....	210
9.2.3	Adjustment Operation Area .....	211

## 9.1 Virtual Memory Space



The virtual memory space is the memory area that can be accessed by using MEM\_RD command and MEM\_WR command.

By adopting the concept of virtual memory, the memory areas that vary among devices and vendors can be accessed at common addresses.

### 9.1.1 $\Sigma$ -7S/ $\Sigma$ -XS SERVOPACKs

**Information** The difference between  $\Sigma$ -7S/ $\Sigma$ -XS SERVOPACKs and  $\Sigma$ -7W/ $\Sigma$ -XW/ $\Sigma$ -XT SERVOPACKs is only the presence or absence of areas due to the different number of axes.





Virtual Memory Address [h]

FFFF FFFF 8000 4004	Reserved.	
8000 4003 8000 4000	Adjustment Operation Area	 <a href="#">9.2.3 Adjustment Operation Area on page 211</a>
8000 3FFF 1002 0000	Reserved.	
1001 FFFF 1001 0000	$\Sigma$ -LINK II Area	$\Sigma$ -LINK II is a valid function only if you are using a $\Sigma$ -X SERVOPACK.
0FFF FFFF 0002 0000	Reserved.	
0001 FFFF 0001 0000	Common Parameter Area	 <a href="#">9.2.2 Common Parameter Area on page 210</a>
0000 FFFF 0000 4000	Reserved.	
0000 3FFF 0000 0000	ID Information Area	 <a href="#">9.2.1 ID Information Area on page 209</a>

## 9.1.2 $\Sigma$ -7W/ $\Sigma$ -XW SERVOPACKs

**Information** The difference between  $\Sigma$ -7W/ $\Sigma$ -XW SERVOPACKs and  $\Sigma$ -7S/ $\Sigma$ -XS/ $\Sigma$ -XT SERVOPACKs is only the presence or absence of areas due to the different number of axes.



Virtual Memory Address [h]

FFFF FFFF 8010 4004	Reserved.	
8010 4003 8010 4000	Adjustment Operation Area (Axis B)	 <a href="#">9.2.3 Adjustment Operation Area on page 211</a>
8010 3FFF 8000 4004	Reserved.	
8000 4003 8000 4000	Adjustment Operation Area (Axis A)	 <a href="#">9.2.3 Adjustment Operation Area on page 211</a>
8000 3FFF 1003 0000	Reserved.	
1002 FFFF 1002 0000	$\Sigma$ -LINK II Area (CN2B)	$\Sigma$ -LINK II is a valid function only if you are using a $\Sigma$ -X SERVOPACK.
1001 FFFF 1001 0000	$\Sigma$ -LINK II Area (CN2A)	
1000 FFFF 0002 0000	Reserved.	
0001 FFFF 0001 0000	Common Parameter Area	 <a href="#">9.2.2 Common Parameter Area on page 210</a>
0000 FFFF 0000 4000	Reserved.	
0000 3FFF 0000 0000	ID Information Area	 <a href="#">9.2.1 ID Information Area on page 209</a>

## 9.1.3 $\Sigma$ -XT SERVOPACKs



**Information** The difference between  $\Sigma$ -XT SERVOPACKs and  $\Sigma$ -7S/ $\Sigma$ -7W/ $\Sigma$ -XS/ $\Sigma$ -XW SERVOPACKs is only the presence or absence of areas due to the different number of axes.

Virtual Memory Address [h]

FFFF FFFF 8020 4004	Reserved.	
8020 4003 8020 4000	Adjustment Operation Area (Axis A)	 <a href="#">9.2.3 Adjustment Operation Area on page 211</a>
8020 3FFF 8010 4004	Reserved.	
8010 4003 8010 4000	Adjustment Operation Area (Axis B)	 <a href="#">9.2.3 Adjustment Operation Area on page 211</a>
8010 3FFF 8000 4004	Reserved.	
8000 4003 8000 4000	Adjustment Operation Area (Axis A)	 <a href="#">9.2.3 Adjustment Operation Area on page 211</a>
8000 3FFF 1004 0000	Reserved.	

Continued on next page.

Continued from previous page.

1003 FFFF 1003 0000	Σ-LINK II Area (CN2C)	
1002 FFFF 1002 0000	Σ-LINK II Area (CN2B)	
1001 FFFF 1001 0000	Σ-LINK II Area (CN2A)	
1000 FFFF 0002 0000	Reserved.	
0001 FFFF 0001 0000	Common Parameter Area	 <a href="#">9.2.2 Common Parameter Area on page 210</a>
0000 FFFF 0000 4000	Reserved.	
0000 3FFF 0000 0000	ID Information Area	 <a href="#">9.2.1 ID Information Area on page 209</a>

## 9.2 Information Allocated to Virtual Memory

The ID information, common parameter and adjustment operation areas are allocated to virtual memory.

### 9.2.1 ID Information Area

When accessing virtual memory using the MEM\_RD or MEM\_WR command, use virtual memory addresses. The address map is given below.

For details, use the ID\_CODE from the following table and refer to the following section.

[3.1.2 Read ID Command \(ID\\_RD: 03h\) on page 82](#)

Data in this area can also be read by using the ID\_RD command.

**Information** If you are using a  $\Sigma$ -7W/ $\Sigma$ -XW/ $\Sigma$ -XT SERVOPACK, you can select which axis area to access by using the extended address of the axis. Refer to the following section for details on the extended addresses.

[1.3 Information on the Extended Address on page 42](#)

[h]	ID_CODE	[h]	ID_CODE	[h]	ID_CODE		
0000 00DF	List of Supported Main Commands 30h	0000 02BF	Reserved	0000 3FFF	Reserved		
0000 00C0		Reserved	0000 02A0	Sub Device 2 Version	A8h		
0000 00BF			0000 029F	Sub Device 2 Name	A0h		
0000 008C		MAC Address	0000 0280		Reserved	0000 03A0	Sub Device 6 Version
0000 0084		Supported Communication Mode	0000 027F	Reserved	0000 039F	Sub Device 6 Name	
0000 0080			Reserved (00000000h)	0000 0260	Sub Device 1 Version		98h
0000 0070		Number of Transmission Bytes (Current Value)	0000 025F	Sub Device 1 Name	90h	0000 0380	Reserved
0000 006C		Number of Transmission Bytes	0000 0240		Reserved	0000 0360	Sub Device 5 Version
0000 0068		Maximum Value of Communication Cycle	0000 023F	Main Device Name		80h	0000 035F
0000 0064		Minimum Value of Communication Cycle	0000 0220		Reserved	0000 0340	Reserved
0000 0060	Granularity of Transmission Cycle	0000 021F	Reserved	0000 0320		Sub Device 4 Version	C8h
0000 005C	Maximum Value of Transmission Cycle	0000 0200		List of Supported Common Parameters	40h	0000 031F	Sub Device 4 Name
0000 0058	Minimum Value of Transmission Cycle	0000 01FF	List of Supported Subcommands		38h	0000 0300	
0000 0054	Profile Version 3	0000 0120		Reserved	0000 02FF	Sub Device 3 Version	B8h
0000 0050	Profile Type 3	0000 011F	Reserved		0000 02E0	Sub Device 3 Name	B0h
0000 004C	Profile Version 2	0000 0110		Reserved	0000 02DF		Reserved
0000 0048	Profile Type 2	0000 0100	Reserved		0000 02D0	Reserved	
0000 0044	Profile Version 1	0000 00FF		Reserved	0000 02C0		Reserved
0000 0040	Profile Type 1	0000 00E0	Reserved			Reserved	
0000 003C	Reserved (00000000h)			Reserved			Reserved
0000 0038	Reserved (00000000h)		Reserved			Reserved	
0000 0034	Serial No.	06h		Reserved			Reserved
0000 0018	Supported Extended Address	05h	Reserved			Reserved	
0000 0014	Device Definition File Version	04h		Reserved			Reserved
0000 0010	Device Version	03h	Reserved			Reserved	
0000 000C	Device Code	02h		Reserved			Reserved
0000 0008	Vendor ID Code	01h	Reserved			Reserved	
0000 0004	Reserved (00000000h)			Reserved			Reserved
0000 0000	Reserved (00000000h)		Reserved			Reserved	

## 9.2.2 Common Parameter Area

When accessing virtual memory using the MEM\_RD or MEM\_WR command, use virtual memory addresses. The address map is given below.

For details, use the common parameter number from the following table and refer to the following section.

[8.2 List of Common Parameters on page 189](#)

Data in this area can also be read using the SVPRM\_RD or SVPRM\_WR command.

**Information** If you are using a  $\Sigma$ -7W/ $\Sigma$ -XW/ $\Sigma$ -XT SERVOPACK, you can select which axis area to access by using the extended address of the axis. Refer to the following section for details on the extended addresses.

[1.3 Information on the Extended Address on page 42](#)

[h]	Common Parameter No.	[h]	Common Parameter No.		
0001 0124	Supported Unit	49h	0001 FFFF	Reserved (00000000h)	-
0001 0120	Torque Base Unit	48h			
0001 011C	Torque Unit	47h	0001 0250		
0001 0118	Acceleration Base Unit	46h	0001 024C	I/O Bit Enabled/Disabled	93h
0001 0114	Acceleration Unit	45h	0001 0248	I/O Bit Enabled/Disabled	92h
0001 0110	Position Base Unit	44h	0001 0244	SVCMD_STAT field Enabled/Disabled	91h
0001 010C	Position Unit	43h	0001 0240	SVCMD_CTRL field Enabled/Disabled	90h
0001 0108	Speed Base Unit	42h	0001 023C	Speed Coincidence Signal Output Width	8Fh
0001 0104	Speed Unit	41h	0001 0238	Zero Speed Detection Range	8Eh
0001 0100	Reserved (00000000h)	-	0001 0234	Zero Speed Detection Range	8Dh
0001 00FC	Reserved (00000000h)	-	0001 0230	Forward Torque Limit	8Ch
0001 00A4	Reverse Software Limit	28h	0001 022C	Origin Detection Range	8Bh
0001 00A0	Reserved (00000000h)	-	0001 0228	Monitor Select for SEL_MON 2	8Ah
0001 009C	Forward Software Limit	26h	0001 0224	Monitor Select for SEL_MON 1	89h
0001 0098	Limit Setting	25h	0001 0220	Monitor Selection 2	88h
0001 0094	Multiturn Limit	24h	0001 021C	Monitor Selection 1	87h
0001 0090	Absolute Encoder Origin Offset	23h	0001 0218	Final Travel Distance for Homing	86h
0001 0088	Electronic Gear Ratio (Denominator)	22h	0001 0214	Homing Creep Speed	85h
0001 0084	Electronic Gear Ratio (Numerator)	21h	0001 0210	Homing Approach Speed	84h
0001 0080	Reserved (00000000h)	-	0001 020C	Final Travel Distance for External Positioning	83h
0001 0034	Pulses per Scale Pitch	0Ch	0001 0208	Movement Average Time	82h
0001 0030	Linear Scale Pitch	0Bh	0001 0204	Exponential Function Acceleration/Deceleration Time Constant	81h
0001 0028	Resolution (Rotary)	0Ah	0001 0200	Reserved (00000000h)	-
0001 0024	Torque Multiplier	09h	0001 01FC	Reserved (00000000h)	-
0001 0020	Maximum Output Torque	08h	0001 01A0	NEAR Signal Width	67h
0001 001C	Rated Torque	07h	0001 019C	Positioning Completed Width	66h
0001 0018	Speed Multiplier	06h	0001 0198	Position Loop Integral Time Constant	65h
0001 0014	Maximum Output Speed	05h	0001 0194	Feedforward Compensation	64h
0001 0010	Rated Speed	04h	0001 0190	Position Loop Gain	63h
0001 000C	Semi-Closed/Fully-Closed Type	03h	0001 018C	Speed Loop Integral Time Constant	62h
0001 0008	Motor Type	02h	0001 0188	Speed Loop Gain	61h
0001 0004	Encoder Type	01h	0001 0184	Reserved (00000000h)	-
0001 0000	Reserved (00000000h)	-	0001 0180		
			0001 0128		

## 9.2.3 Adjustment Operation Area

Use the MEM\_RD or MEM\_WR command to access this area. The address map is given below.  
Refer to the following section for the command communications procedure for adjustment operations.

 [3.1.10 Write Memory Command \(MEM\\_WR: 1Eh\) on page 98](#)

**Information** If you are using a  $\Sigma$ -7W/ $\Sigma$ -XW/ $\Sigma$ -XT SERVOPACK, the following table lists only axis A addresses.  
For axis B addresses, add "0010 0000h" to the addresses listed in the following table.  
For axis C addresses, add "0020 0000h" to the addresses listed in the following table.

Address for Virtual Memory Space	Name/Description	Data Type
8000 4000 [h] to 8000 4001 [h]	Command code The area where the command codes specifying adjustment operations are written	Binary data
8000 4002 [h] to 8000 4003 [h]	Start command The area where commands for preparing or starting adjustment operations are written	Binary data









## Appendices

---

10.1	Differences Between MECHATROLINK Commands for $\Sigma$ -7 SERVO- PACKs and $\Sigma$ -X SERVOPACKs .....	214
------	--	-----

## 10.1 Differences Between MECHATROLINK Commands for $\Sigma$ -7 SERVOPACKs and $\Sigma$ -X SERVOPACKs

The following table lists the differences between MECHATROLINK commands for  $\Sigma$ -7 SERVOPACKs and  $\Sigma$ -X SERVOPACKs.

Item	$\Sigma$ -7 SERVOPACKs		$\Sigma$ -X SERVOPACKs			Reference
	$\Sigma$ -7S	$\Sigma$ -7W	$\Sigma$ -XS	$\Sigma$ -XW	$\Sigma$ -XT	
SVCMD_IO Field: SO1 to SO5 and SLO1 to SLO4	SO1 to SO3: Supported SO4, SO5: Not supported SLO1 to SLO4: Not supported	SO1 to SO5: Supported SLO1 to SLO4: Not supported	SO1 to SO3: Supported SO4, SO5: Not supported SLO1 to SLO4: Supported	SO1 to SO5: Supported SLO1 to SLO4: Supported		 (a) SVCMD_IO (Output) Field on page 70
SVCMD_IO Field: FOUT_STOP	Supported by SERVOPACKs with FT/EX specifications only. For details, refer to the following section.	Not supported	Supported			
Servomotor Resolution	24 bit: Supported 26 bit: Not supported		24 bit: Supported 26 bit: Supported			 3.2.20 Restrictions in Using Servo Commands on page 126
ID_CODE in ID_RD Command	For details, refer to the following section.					 (2) Command Parameters on page 82
EX_POSING Command S-curve Acceleration/Deceleration	Not supported		Supported			 (3) Operation for S-Curve Acceleration/Deceleration on page 111  3.2.13 External Input Positioning Command (EX_POSING: 39h) on page 116
Common Parameters	For details, refer to the following section.					 8.3 Differences between the Common Parameters on page 200
Virtual Memory Space	For details, refer to the following section.					 9.1 Virtual Memory Space on page 206

## Revision History

The date of publication, revision code, revision number, and web revision number are given at the bottom right of the back cover. Refer to the following example.

MANUAL NO. SIEP S800001 31A <0>-0  
 Published in Japan April 2014

Revision number  
 Revision code      Web revision number

Date of publication

Date of Publication	Rev. Code	Rev. No.	Web Rev. No.	Section	Revised Contents
March 2026	J	<9>	0	All chapters	Partly revised.
February 2025	I	<8>	0	Preface, 2.5.3, 3.1.10, 3.1.20, 3.2.19	Partly revised.
				Back cover	Revision: Address
January 2023	H	<7>	0	All chapters	Addition: Information on $\Sigma$ -XT
				Back cover	Revision: Address
November 2021	G	<6>	0	All chapters	Partly revised.
				1.6.4 (2)	Addition: Combinations of Main Commands and Subcommands (for $\Sigma$ -X SERVOPACKS)
				5.5.1	Addition: Operating Sequence When the Overtravel Alarm Is Used
				6.8	Addition: Triggers at Preset Positions
				Back cover	Revision: Address
May 2021	F	<5>	0	All chapters	Addition: Information on $\Sigma$ -X
September 2019	E	<4>	0	6.2, 6.3.1	Deletion: Description of the Position Control Command TFF/TLIM Allocation (Pn81F)
March 2019	D	<3>	0	Preface	Partly revised.
				2.6.1	Revision: Description of the SVCMD_IO (Output) field
				Back cover	Revision: Address
October 2017	C	<2>	1	2.6.1	Revision: Description of the SVCMD_IO (Output) field
June 2017			0	Front cover	Revision: Format
			Preface	Partly revised.	
			2.5.1, 2.6, 3.1.2, 5.1	Addition: Information on the $\Sigma$ -7F integrated servomotor (Model: SGF7□-□□□□□□□□2□)	
			2.7.3	Revision: Monitor data list	
			3.2.18	Revision: Description of data format	
			Back cover	Revision: Address	
February 2015	B	<1>	0	All chapters	Complete review.
				Back cover	Revision: Address
April 2014	A	-	-	-	First edition

# Σ-7/Σ-X-Series AC Servo Drive

# MECHATROLINK-III

# Communications

# Standard Servo Profile

# Command Manual

---

#### **IRUMA BUSINESS CENTER (SOLUTION CENTER)**

480, Kamifujisawa, Iruma, Saitama, 358-8555, Japan  
Phone: +81-4-2962-5151 Fax: +81-4-2962-6138  
www.yaskawa.co.jp

#### **YASKAWA AMERICA, INC.**

2121, Norman Drive South, Waukegan, IL 60085, U.S.A.  
Phone: +1-800-YASKAWA (927-5292) or +1-847-887-7000 Fax: +1-847-887-7310  
www.yaskawa.com

#### **YASKAWA ELÉTRICO DO BRASIL LTDA.**

777, Avenida Piraporinha, Diadema, São Paulo, 09950-000, Brasil  
Phone: +55-11-3585-1100 Fax: +55-11-3585-1187  
www.yaskawa.com.br

#### **YASKAWA EUROPE GmbH**

Philipp-Reis-Str. 6, 65795 Hattersheim am Main, Germany  
Phone: +49-6196-569-300  
www.yaskawa.eu.com E-mail: support@yaskawa.eu

#### **YASKAWA ELECTRIC KOREA CORPORATION**

6F, 112, LS-ro, Dongan-gu, Anyang-si, Gyeonggi-do, Korea  
Phone: +82-31-8015-4224 Fax: +82-31-8015-5034  
www.yaskawa.co.kr

#### **YASKAWA ASIA PACIFIC PTE. LTD.**

30A, Kallang Place, #06-01, 339213, Singapore  
Phone: +65-6282-3003 Fax: +65-6289-3003  
www.yaskawa.com.sg

#### **YASKAWA ELECTRIC (THAILAND) CO., LTD.**

59, 1F-5F, Flourish Building, Soi Ratchadapisek 18, Ratchadapisek Road, Huaykwang, Bangkok, 10310, Thailand  
Phone: +66-2-017-0099 Fax: +66-2-017-0799  
www.yaskawa.co.th

#### **YASKAWA ELECTRIC (CHINA) CO., LTD.**

22F, Link Square 1, No.222, Hubin Road, Shanghai, 200021, China  
Phone: +86-21-5385-2200 Fax: +86-21-5385-3299  
www.yaskawa.com.cn

#### **YASKAWA ELECTRIC (CHINA) CO., LTD. BEIJING OFFICE**

Room 1011, Tower W3 Oriental Plaza, No.1, East Chang An Avenue,  
Dong Cheng District, Beijing, 100738, China  
Phone: +86-10-8518-4086 Fax: +86-10-8518-4082

#### **YASKAWA ELECTRIC TAIWAN CORPORATION**

12F, No. 207, Section 3, Beishin Road, Shindian District, New Taipei City 23143, Taiwan  
Phone: +886-2-8913-1333 Fax: +886-2-8913-1513 or +886-2-8913-1519  
www.yaskawa.com.tw

---

# YASKAWA

YASKAWA ELECTRIC CORPORATION

In the event that the end user of this product is to be the military and said product is to be employed in any weapons systems or the manufacture thereof, the export will fall under the relevant regulations as stipulated in the Foreign Exchange and Foreign Trade Act. Therefore, be sure to follow all procedures and submit all relevant documentation according to any and all rules, regulations and laws that may apply.

Specifications are subject to change without notice for ongoing product modifications and improvements.

© 2014 YASKAWA Electric Corporation

MANUAL NO. SIEP S800001 31J <9>-0  
Published in Japan March 2026  
25-9-21  
Original instructions