

Σ-7-Series AC Servo Drive Peripheral Device Selection Manual

Applicable SERVOPACK Model: SGD7S, SGD7W, SGD7C

Applicable Rotary Servomotor Model: SGM7M, SGM7J, SGM7A, SGM7P, SGM7G, SGMMV

Applicable Direct Drive Servomotor Model: SGM7D, SGM7E, SGM7F, SGM7CV, SGM7CS

Applicable Linear Servomotor Model: SGLG, SGLF, SGLT

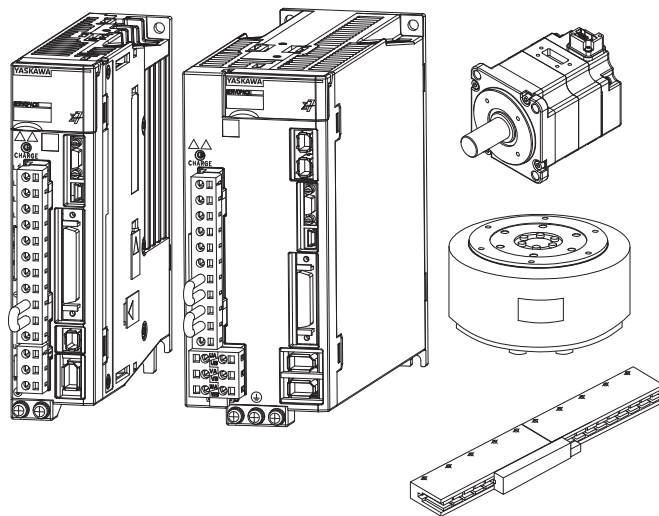

Peripheral Devices and System Configurations	1
Cables and User-Assembled Wiring Materials for SGM7M Rotary Servomotors	2
Cables and User-Assembled Wiring Materials for SGM7J Rotary Servomotors	3
Cables and User-Assembled Wiring Materials for SGM7A Rotary Servomotors	4
Cables and User-Assembled Wiring Materials for SGM7P Rotary Servomotors	5
Cables and User-Assembled Wiring Materials for SGM7G Rotary Servomotors	6
Cables and User-Assembled Wiring Materials for SGMMV Rotary Servomotors	7
Cables and User-Assembled Wiring Materials for Direct Drive Servomotors	8
Cables and User-Assembled Wiring Materials for Linear Servomotors	9
Cables and User-Assembled Wiring Materials for SERVOPACKs	10
Option Modules	11
SERVOPACK Peripheral Devices	12
Software	13
Other Peripheral Devices and Options	14

Copyright © 2014 YASKAWA ELECTRIC CORPORATION

All rights reserved. No part of this publication may be reproduced, stored in a retrieval system, or transmitted, in any form, or by any means, mechanical, electronic, photocopying, recording, or otherwise, without the prior written permission of Yaskawa. No patent liability is assumed with respect to the use of the information contained herein. Moreover, because Yaskawa is constantly striving to improve its high-quality products, the information contained in this manual is subject to change without notice. Every precaution has been taken in the preparation of this manual. Nevertheless, Yaskawa assumes no responsibility for errors or omissions. Neither is any liability assumed for damages resulting from the use of the information contained in this publication.

About this Manual

This manual provides information required to select cables, peripheral devices, and options for Σ -7-Series AC Servo Drives. It also describes the wiring materials that you can use to make your own cables. Read and understand this manual to ensure correct usage of the Σ -7-Series AC Servo Drives. Keep this manual in a safe place so that it can be referred to whenever necessary.

Outline of Manual

The contents of the chapters of this manual are described in the following table. Refer to these chapters as required.

Chapter	Chapter Title	Contents
1	Peripheral Devices and System Configurations	This chapter provides system configuration diagrams of Servo Drives and peripheral devices. References are provided to detailed information.
2	Cables and User-Assembled Wiring Materials for SGM7M Rotary Servomotors	<p>These chapters provide the following information.</p> <ul style="list-style-type: none"> • Selection tables, specifications, and dimensional drawings for Servomotor Main Circuit Cables, Encoder Cables, and user-assembled wiring materials <p>Note: References to detailed information are provided in the system configuration diagrams.</p>
3	Cables and User-Assembled Wiring Materials for SGM7J Rotary Servomotors	
4	Cables and User-Assembled Wiring Materials for SGM7A Rotary Servomotors	
5	Cables and User-Assembled Wiring Materials for SGM7P Rotary Servomotors	
6	Cables and User-Assembled Wiring Materials for SGM7G Rotary Servomotors	
7	Cables and User-Assembled Wiring Materials for SGMMV Rotary Servomotors	
8	Cables and User-Assembled Wiring Materials for Direct Drive Servomotors	
9	Cables and User-Assembled Wiring Materials for Linear Servomotors	
10	Cables and User-Assembled Wiring Materials for SERVOPACKs	This chapter provides selection tables, specifications, and dimensional drawings for SERVOPACK cables.
11	Option Modules	This chapter provides the specifications and dimensional drawings of Option Modules.
12	SERVOPACK Peripheral Devices	This chapter provides selection tables, specifications, and dimensional drawings for SERVOPACK peripheral devices.
13	Software	This chapter provides information on the SigmaWin+, Yaskawa's AC Servo Drive Engineering Tool, and MPE720, our System Integrated Engineering Tool.
14	Other Peripheral Devices and Options	This chapter provides information on surge absorbers and diodes for holding brake power supplies. It also provides information on the battery required to use an absolute encoder. And it provides information on the compatibility of cables for Σ -V-Series Servomotors and information on metal connectors.

Related Documents

The relationships between the documents that are related to the Servo Drives are shown in the following figure. The numbers in the figure correspond to the numbers in the table on the following pages. Refer to these documents as required.

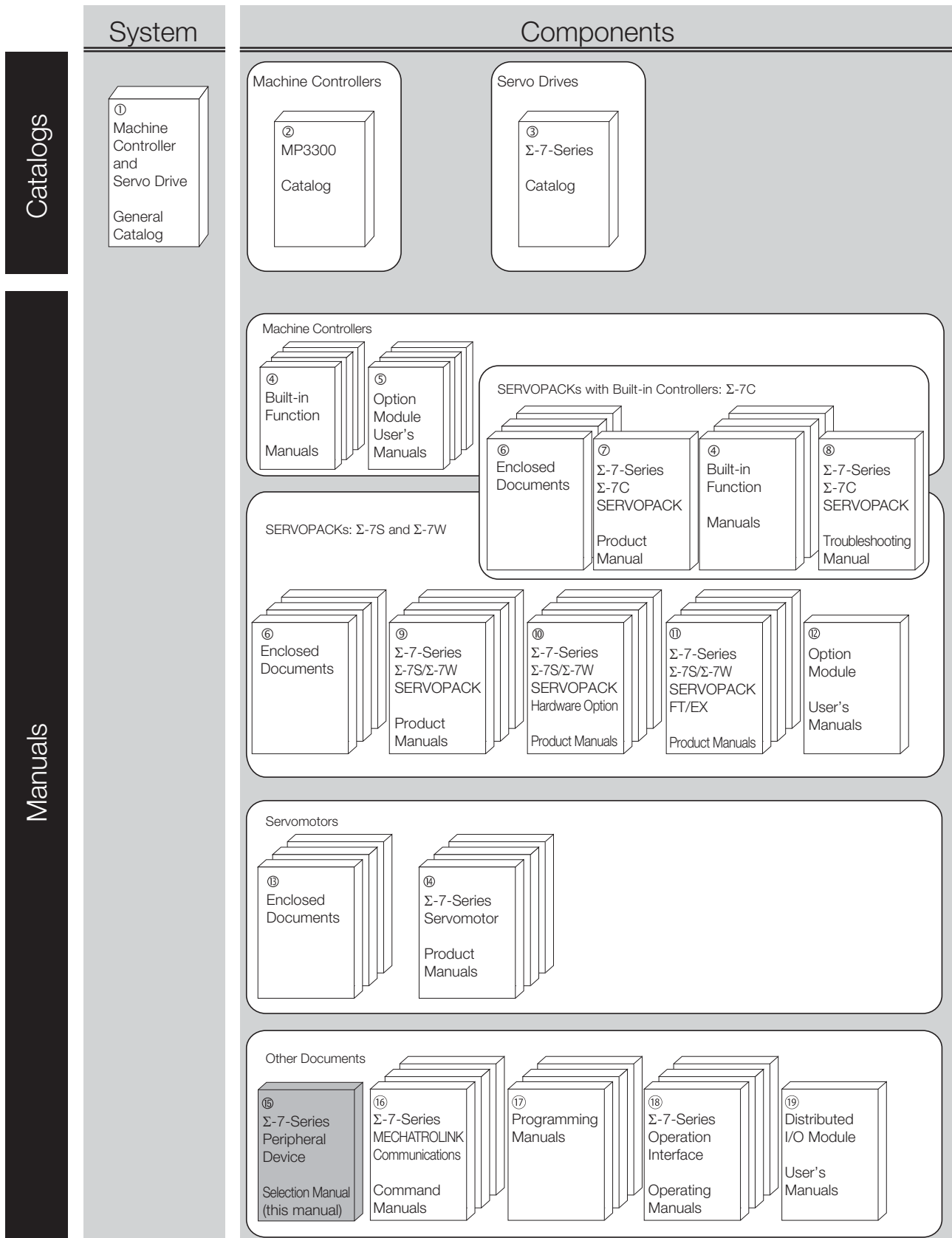

Classification	Document Name	Document No.	Description
① Machine Controller and Servo Drive General Catalog	Machine Controller and AC Servo Drive Solutions Catalog	KAEP S800001 22	Describes the features and application examples for combinations of MP3000-Series Machine Controllers and Σ -7-Series AC Servo Drives.
② MP3300 Catalog	Machine Controller MP3300	KAEP C880725 03	Provides detailed information on MP3300 Machine Controllers, including features and specifications.
③ Σ -7-Series Catalog	AC Servo Drives Σ -7 Series	KAEP S800001 23	Provides detailed information on Σ -7-Series AC Servo Drives, including features and specifications.
④ Built-in Function Manuals	Σ -7-Series AC Servo Drive Σ -7C SERVOPACK Motion Control User's Manual	SIEP S800002 03	Provides detailed information on the specifications, system configuration, and application methods of the Motion Control Function Modules (SVD, SVC4, and SVR4) for Σ -7-Series Σ -7C SERVOPACKs.
	Machine Controller MP3000 Series Communications User's Manual	SIEP C880725 12	Provides detailed information on the specifications, system configuration, and communications connection methods for the Ethernet communications that are used with MP3000-Series Machine Controllers and Σ -7-Series Σ -7C SERVOPACKs.
⑤ Option Module User's Manuals	Machine Controller MP2000 Series Communication Module User's Manual	SIEP C880700 04	Provide detailed information on the specifications and communications methods for the Communications Modules that can be mounted to MP3000-Series Machine Controllers and Σ -7-Series Σ -7C SERVOPACKs.
	Machine Controller MP2000 Series 262IF-01 FL-net Communication Module User's Manual	SIEP C880700 36	
	Machine Controller MP2000 Series 263IF-01 EtherNet/IP Communication Module User's Manual	SIEP C880700 39	
	Machine Controller MP2000 Series I/O Module User's Manual	SIEP C880700 34	Provide detailed information on the specifications and communications methods for the I/O Modules that can be mounted to MP3000-Series Machine Controllers and Σ -7-Series Σ -7C SERVOPACKs.
	Machine Controller MP2000 Series Analog Input/Analog Output Module AI-01/AO-01 User's Manual	SIEP C880700 26	
	Machine Controller MP2000 Series Counter Module CNTR-01 User's Manual	SIEP C880700 27	

Continued on next page.

Continued from previous page.

Classification	Document Name	Document No.	Description
⑥ Enclosed Documents	Σ-7-Series AC Servo Drive Σ-7S, Σ-7W, and Σ-7C SER- VOPACK Safety Precautions	TOMP C710828 00	Provides detailed information for the safe usage of Σ-7-Series SERVOPACKS.
	Σ-V-Series/Σ-V-Series for Large-Capacity Models/ Σ-7-Series Safety Precautions Option Module	TOBP C720829 00	Provides detailed information for the safe usage of Option Modules.
	Σ-V-Series/Σ-V-Series for Large-Capacity Models/ Σ-7-Series Installation Guide Command Option Module	TOBP C720829 01	Provides detailed procedures for installing the Command Option Module in a SERVOPACK.
	Σ-V-Series/Σ-V-Series for Large-Capacity Models/ Σ-7-Series Installation Guide Fully-closed Module	TOBP C720829 03	Provides detailed procedures for installing the Fully-closed Module in a SERVOPACK.
	Σ-V-Series/Σ-V-Series for Large-Capacity Models/ Σ-7-Series Installation Guide Safety Module	TOBP C720829 06	Provides detailed procedures for installing the Safety Module in a SERVOPACK.
	Σ-V-Series/Σ-V-Series for Large-Capacity Models/ Σ-7-Series Installation Guide INDEXER Module	TOBP C720829 02	Provides detailed procedures for installing the INDEXER Module in a SERVOPACK.
	Σ-V-Series/Σ-V-Series for Large-Capacity Models/ Σ-7-Series Installation Guide DeviceNet Module	TOBP C720829 07	Provides detailed procedures for installing the DeviceNet Module in a SERVOPACK.
⑦ Σ-7-Series Σ-7C SERVOPACK Product Manual	Σ-7-Series AC Servo Drive Σ-7C SERVOPACK Product Manual	SIEP S800002 04	Provides detailed information on selecting Σ-7-Series Σ-7C SERVOPACKS; installing, connecting, setting, testing in trial operation, and tuning Servo Drives; writing, monitoring, and maintaining programs; and other information.
⑧ Σ-7-Series Σ-7C SERVOPACK Troubleshooting Manual	Σ-7-Series AC Servo Drive Σ-7C SERVOPACK Troubleshooting Manual	SIEP S800002 07	Provides detailed troubleshooting information for Σ-7-Series Σ-7C SERVOPACKS.

Continued on next page.

Continued from previous page.

Classification	Document Name	Document No.	Description
⑨ Σ-7-Series Σ-7S/Σ-7W SERVOPACK Product Manuals	Σ-7-Series AC Servo Drive Σ-7S SERVOPACK with MECHATROLINK-4 Communications References Product Manual	SIEP S800002 31	Provide detailed information on selecting Σ-7-Series Σ-7S and Σ-7W SERVOPACKs; installing, connecting, setting, testing in trial operation, tuning, monitoring, and maintaining Servo Drives; and other information.
	Σ-7-Series AC Servo Drive Σ-7S SERVOPACK with MECHATROLINK-III Communications References Product Manual	SIEP S800001 28	
	Σ-7-Series AC Servo Drive Σ-7S SERVOPACK with MECHATROLINK-II Communications References Product Manual	SIEP S800001 27	
	Σ-7-Series AC Servo Drive Σ-7S SERVOPACK with Analog Voltage/Pulse Train References Product Manual	SIEP S800001 26	
	Σ-7-Series AC Servo Drive Σ-7S SERVOPACK Command Option Attachable Type with INDEXER Module Product Manual	SIEP S800001 64	
	Σ-7-Series AC Servo Drive Σ-7S SERVOPACK Command Option Attachable Type with DeviceNet Module Product Manual	SIEP S800001 70	
	Σ-7-Series AC Servo Drive Σ-7W SERVOPACK with MECHATROLINK-III Communications References Product Manual	SIEP S800001 29	
⑩ Σ-7-Series Σ-7S/Σ-7W SERVOPACK with Hardware Option Specifications Product Manuals	Σ-7-Series AC Servo Drive Σ-7S/Σ-7W SERVOPACK with Hardware Option Specifica- tions Dynamic Brake Product Manual	SIEP S800001 73	Provides detailed information on Hardware Options for Σ-7-Series SERVOPACKs.
	Σ-7-Series AC Servo Drive Σ-7W/Σ-7C SERVOPACK with Hardware Option Specifica- tions HWBB Function Product Manual	SIEP S800001 72	

Continued on next page.

Continued from previous page.

Classification	Document Name	Document No.	Description
⑩ Σ-7-Series Σ-7S/Σ-7W SERVOPACK FT/EX Product Manuals	Σ-7-Series AC Servo Drive Σ-7S SERVOPACK with FT/EX Specification for Index- ing Application Product Manual	SIEP S800001 84	Provides detailed information on the FT/EX Option for Σ-7-Series SERVOPACKS.
	Σ-7-Series AC Servo Drive Σ-7S SERVOPACK with FT/EX Specification for Track- ing Application Product Manual	SIEP S800001 89	
	Σ-7-Series AC Servo Drive Σ-7S SERVOPACK with FT/EX Specification for Application with Special Motor, SGM7D Motor Product Manual	SIEP S800001 91	
	Σ-7-Series AC Servo Drive Σ-7S SERVOPACK with FT/EX Specification for Press and Injection Molding Application Product Manual	SIEP S800001 94	
	Σ-7-Series AC Servo Drive Σ-7S SERVOPACK with FT/EX Specification for Transfer and Alignment Application Product Manual	SIEP S800001 95	
	Σ-7-Series AC Servo Drive Σ-7S SERVOPACK with FT/EX Specification for Torque/Force Assistance for Conveyance Application Product Manual	SIEP S800002 09	
	Σ-7-Series AC Servo Drive Σ-7S SERVOPACK with FT/EX Specification for Cutting Application Feed Shaft Motor Product Manual	SIEP S800002 10	
	Σ-7-Series AC Servo Drive Σ-7S SERVOPACK with FT/EX Specification for Three-Point Latching for Conveyance Application Product Manual	SIEP S800002 17	
	Σ-7-Series AC Servo Drive Σ-7S SERVOPACK with FT/EX Specification for Semi-/Fully-Closed Loop Control Online Switching for Conveyance Application Product Manual	SIEP S800002 27	
	Σ-7-Series AC Servo Drive Σ-7W SERVOPACK with FT/EX Specification for Gantry Applications Product Manual	SIEP S800002 29	

Continued on next page.

Continued from previous page.

Classification	Document Name	Document No.	Description
⑫ Option Module User's Manual	AC Servo Drives Σ -V-Series/ Σ -V-Series for Large-Capacity Models/ Σ -7-Series User's Manual Safety Module	SIEP C720829 06	Provides detailed information required for the design and mainte- nance of a Safety Module.
⑬ Enclosed Documents	AC Servo Drive Rotary Servomotor Safety Precautions	TOBP C230260 00	Provides detailed information for the safe usage of Rotary Servomo- tors and Direct Drive Servomotors.
	AC Servomotor Linear Σ Series Safety Precautions	TOBP C230800 00	Provides detailed information for the safe usage of Linear Servomo- tors.
⑭ Σ -7-Series Servomotor Product Manuals	Σ -7-Series AC Servo Drive Rotary Servomotor Product Manual	SIEP S800001 36	Provide detailed information on selecting, installing, and connecting the Σ -7-Series Servomotors.
	Σ -7-Series AC Servo Drive Linear Servomotor Product Manual	SIEP S800001 37	
	Σ -7-Series AC Servo Drive Direct Drive Servomotor Product Manual	SIEP S800001 38	
⑮ Σ -7-Series Peripheral Device Selection Manual	Σ -7-Series AC Servo Drive Peripheral Device Selection Manual	This manual (SIEP S800001 32)	Provides the following information in detail for Σ -7-Series Servo Sys- tems. • Cables: Models, dimensions, wir- ing materials, connector models, and connection specifications • Peripheral devices: Models, specifications, diagrams, and selection (calculation) methods
⑯ Σ -7-Series MECHATROLINK Communications Command Manuals	Σ -7-Series AC Servo Drive MECHATROLINK-II Communications Command Manual	SIEP S800001 30	Provides detailed information on the MECHATROLINK-II communi- cations commands that are used for a Σ -7-Series Servo System.
	Σ -7-Series AC Servo Drive MECHATROLINK-III Communications Standard Servo Profile Command Manual	SIEP S800001 31	Provides detailed information on the MECHATROLINK-III communi- cations standard servo profile com- mands that are used for a Σ -7- Series Servo System.
	Σ -7-Series AC Servo Drive MECHATROLINK-4 Communications Standard Servo Profile Command Manual	SIEP S800002 32	Provides detailed information on the MECHATROLINK-4 communi- cations standard servo profile com- mands that are used for a Σ -7- Series Servo System.
⑰ Programming Manuals	Machine Controller MP3000 Series Ladder Programming Manual	SIEP C880725 13	Provides detailed information on the ladder programming specifica- tions and instructions for MP3000- Series Machine Controllers and Σ -7-Series Σ -7C SERVOPACKs.
	Machine Controller MP3000 Series Motion Programming Manual	SIEP C880725 14	Provides detailed information on the motion programming and sequence programming specifica- tions and instructions for MP3000- Series Machine Controllers and Σ -7-Series Σ -7C SERVOPACKs.

Continued on next page.

Continued from previous page.

Classification	Document Name	Document No.	Description
¹⁸ Σ -7-Series Operation Interface Operating Manuals	Machine Controller MP2000/MP3000 Series Engineering Tool MPE720 Version 7 User's Manual	SIEP C880761 03	Describes in detail how to operate MPE720 version 7.
	Σ -7-Series AC Servo Drive Digital Operator Operating Manual	SIEP S800001 33	Describes the operating procedures for a Digital Operator for a Σ -7-Series Servo System.
	AC Servo Drive Engineering Tool SigmaWin+ Operation Manual	SIET S800001 34	Provides detailed operating procedures for the SigmaWin+ Engineering Tool for a Σ -7-Series Servo System.
¹⁹ Distributed I/O Module User's Manual	MECHATROLINK-III Compatible I/O Module User's Manual	SIEP C880781 04	Describes the functions, specifications, operating methods, and MECHATROLINK-III communications for the Remote I/O Modules for MP2000/MP3000-Series Machine Controllers.
	MECHATROLINK-4 Compatible I/O Module User's Manual	SIEP C880782 01	Describes the functions, specifications, operating methods, and MECHATROLINK-4 communications for the Remote I/O Modules for MP3000-Series Machine Controllers.

Using This Manual

◆ Technical Terms Used in This Manual

The following terms are used in this manual.

Term	Meaning
Servomotor	A Σ -7-Series Rotary Servomotor, Direct Drive Servomotor, or Linear Servomotor.
Rotary Servomotor	A Rotary Servomotor (SGM7M, SGM7J, SGM7A, SGM7P, SGM7G, or SGMMV).
Direct Drive Servomotor	A Direct Drive Servomotor (SGM7D, SGM7E, SGM7F, SGM7CV, or SGM7CS).
Linear Servomotor	A Σ -7-Series Linear Servomotor (SGLG, SGLF, or SGLT).
SERVOPACK	A Σ -7-Series amplifier.
Servo Drive	The combination of a Servomotor and SERVOPACK.
Servo System	A servo control system that includes the combination of a Servo Drive with a host controller and peripheral devices.
Main Circuit Cable	One of the cables that connect to the main circuit terminals, including the Main Circuit Power Supply Cable, Control Power Supply Cable, and Servomotor Main Circuit Cable.
SigmaWin+	The Engineering Tool for setting up and tuning Servo Drives or a computer in which the Engineering Tool is installed.
absolute encoder	The general term used for absolute encoders with batteries and batteryless absolute encoders. In cases where the general term causes confusion, the term "batteryless absolute encoder" may also be used.

◆ Trademarks

- Ethernet is a registered trademark of the Xerox Corporation.
- EtherCAT® is a registered trademark and patented technology, licensed by Beckhoff Automation GmbH, Germany.
- EtherNet/IP is a registered trademark of ODVA (Open DeviceNet Vendor Association, Inc.).
- DeviceNet is a registered trademark of ODVA (Open DeviceNet Vendor Association, Inc.).
- MECHATROLINK is a trademark of the MECHATROLINK Members Association.
- Other product names and company names are the trademarks or registered trademarks of the respective company. "TM" and the ® mark do not appear with product or company names in this manual.

◆ Visual Aids

The following aids are used to indicate certain types of information for easier reference.



Indicates precautions or restrictions that must be observed.
Also indicates alarm displays and other precautions that will not result in machine damage.



Indicates definitions of difficult terms or terms that have not been previously explained in this manual.

Example Indicates operating or setting examples.

Information Indicates supplemental information to deepen understanding or useful information.

Safety Precautions

◆ Safety Information

To prevent personal injury and equipment damage in advance, the following signal words are used to indicate safety precautions in this document. The signal words are used to classify the hazards and the degree of damage or injury that may occur if a product is used incorrectly. Information marked as shown below is important for safety. Always read this information and heed the precautions that are provided.

DANGER

- Indicates precautions that, if not heeded, are likely to result in loss of life, serious injury, or fire.

WARNING

- Indicates precautions that, if not heeded, could result in loss of life, serious injury, or fire.

CAUTION

- Indicates precautions that, if not heeded, could result in relatively serious or minor injury, or in fire.

NOTICE

- Indicates precautions that, if not heeded, could result in property damage.

◆ Safety Precautions That Must Always Be Observed

■ General Precautions



DANGER

- Read and understand this manual to ensure the safe usage of the product.
- Keep this manual in a safe, convenient place so that it can be referred to whenever necessary. Make sure that it is delivered to the final user of the product.
- Do not remove covers, cables, connectors, or optional devices while power is being supplied to the SERVOPACK.
There is a risk of electric shock, operational failure of the product, or burning.



WARNING

- Use a power supply with specifications (number of phases, voltage, frequency, and AC/DC type) that are appropriate for the product.
There is a risk of burning, electric shock, or fire.
- Do not attempt to disassemble, repair, or modify the product.
There is a risk of fire or failure.
The warranty is void for the product if you disassemble, repair, or modify it.



CAUTION

- The regenerative resistors, External Dynamic Brake Resistors, and other peripheral devices can be very hot while power is ON or soon after the power is turned OFF. Implement safety measures, such as installing covers, so that hands and parts such as cables do not come into contact with hot components.
There is a risk of burn injury.
- For a 24-VDC power supply, use a power supply device with double insulation or reinforced insulation.
There is a risk of electric shock.
- Do not damage, pull on, apply excessive force to, place heavy objects on, or pinch cables.
There is a risk of failure, damage, or electric shock.
- Do not use the product in an environment that is subject to water, corrosive gases, or flammable gases, or near flammable materials.
There is a risk of electric shock or fire.

NOTICE

- Do not attempt to use a peripheral device that is damaged or that has missing parts.
- Install external emergency stop circuits that shut OFF the power supply and stops operation immediately when an error occurs.
- In locations with poor power supply conditions, install the necessary protective devices (such as AC reactors) to ensure that the input power is supplied within the specified voltage range.
There is a risk of damage to the SERVOPACK.
- Use a Noise Filter to minimize the effects of electromagnetic interference.
Electronic devices used near the SERVOPACK may be affected by electromagnetic interference.
- Always use peripheral devices in the specified combinations.
- Do not touch peripheral devices with wet hands.
There is a risk of product failure.

■ Storage Precautions

CAUTION

- Do not place an excessive load on the product during storage. (Follow all instructions on the packages.)
There is a risk of injury or damage.

NOTICE

- Do not install or store the product in any of the following locations.
 - Locations that are subject to direct sunlight
 - Locations that are subject to ambient temperatures that exceed product specifications
 - Locations that are subject to relative humidities that exceed product specifications
 - Locations that are subject to condensation as the result of extreme changes in temperature
 - Locations that are subject to corrosive or flammable gases
 - Locations that are near flammable materials
 - Locations that are subject to dust, salts, or iron powder
 - Locations that are subject to water, oil, or chemicals
 - Locations that are subject to vibration or shock that exceeds product specifications
 - Locations that are subject to radiation
- If you store or install the product in any of the above locations, the product may fail or be damaged.

■ Transportation Precautions

CAUTION

- Transport the product in a way that is suitable to the mass of the product.
- When you handle a peripheral device, be careful of sharp parts, such as the corners.
There is a risk of injury.
- Do not place an excessive load on the product during transportation. (Follow all instructions on the packages.)
There is a risk of injury or damage.

NOTICE

- Peripheral devices are precision devices. Do not drop it or subject it to strong shock.
There is a risk of failure or damage.
- Do not subject connectors to shock.
There is a risk of faulty connections or damage.
- If disinfectants or insecticides must be used to treat packing materials such as wooden frames, plywood, or pallets, the packing materials must be treated before the product is packaged, and methods other than fumigation must be used.
Example: Heat treatment, where materials are kiln-dried to a core temperature of 56°C for 30 minutes or more.
If the electronic products, which include stand-alone products and products installed in machines, are packed with fumigated wooden materials, the electrical components may be greatly damaged by the gases or fumes resulting from the fumigation process. In particular, disinfectants containing halogen, which includes chlorine, fluorine, bromine, or iodine can contribute to the erosion of the capacitors.

■ Installation Precautions



CAUTION

- Install a peripheral device in a way that will support the mass given in technical documents.
- Install SERVOPACKs, Servomotors, regenerative resistors, and External Dynamic Brake Resistors on nonflammable materials.
Installation directly onto or near flammable materials may result in fire.
- Install the SERVOPACK in the specified orientation.
There is a risk of fire or failure.
- Do not step on or place a heavy object on the product.
There is a risk of failure, damage, or injury.
- Do not allow any foreign matter to enter a peripheral device.
There is a risk of failure or fire.

NOTICE

- Do not install or store the product in any of the following locations.
 - Locations that are subject to direct sunlight
 - Locations that are subject to ambient temperatures that exceed product specifications
 - Locations that are subject to relative humidities that exceed product specifications
 - Locations that are subject to condensation as the result of extreme changes in temperature
 - Locations that are subject to corrosive or flammable gases
 - Locations that are near flammable materials
 - Locations that are subject to dust, salts, or iron powder
 - Locations that are subject to water, oil, or chemicals
 - Locations that are subject to vibration or shock that exceeds product specifications
 - Locations that are subject to radiationIf you store or install the product in any of the above locations, the product may fail or be damaged.

■ Wiring Precautions



DANGER

- Do not change any wiring while power is being supplied.
There is a risk of electric shock or injury.



WARNING

- Wiring and inspections must be performed only by qualified engineers.
There is a risk of electric shock or product failure.
- Check all wiring and power supplies carefully.
Incorrect wiring or incorrect voltage application to the output circuits may cause short-circuit failures. If a short-circuit failure occurs as a result of any of these causes, the holding brake will not work. This could damage the machine or cause an accident that may result in death or injury.



CAUTION

- Wait for at least six minutes after turning OFF the power supply (with a SERVOPACK for a 100-VAC input, wait for at least nine minutes) and then make sure that the CHARGE indicator is not lit before starting wiring or inspection work. Do not touch the power supply terminals while the CHARGE lamp is lit after turning OFF the power supply because high voltage may still remain in the SERVOPACK.
There is a risk of electric shock.
- Check the wiring to be sure it has been performed correctly.
Always confirm the pin layouts and wiring methods in technical documents for your peripheral devices before operation.
There is a risk of failure or malfunction.
- Connect wires to your peripheral devices securely with the specified methods and tightening torque.
Insufficient tightening may cause wires and terminal blocks to generate heat due to faulty contact, possibly resulting in fire.
- Use shielded twisted-pair cables or screened unshielded multi-twisted-pair cables for I/O Signal Cables and Encoder Cables.
- Always connect the shield wire to the connector case or shell.
There is a risk of failure or malfunction.
- The maximum wiring length is 3 m for I/O Signal Cables, and 50 m for Encoder Cables or Servomotor Main Circuit Cables.
- Observe the following precautions when wiring the SERVOPACK's main circuit terminals.
 - Turn ON the power supply to the SERVOPACK only after all wiring, including the main circuit terminals, has been completed.
 - If a connector is used for the main circuit terminals, remove the main circuit connector from the SERVOPACK before you wire it.
 - Insert only one wire per insertion hole in the main circuit terminals.
 - When you insert a wire, make sure that the conductor wire (e.g., whiskers) does not come into contact with adjacent wires.
- Install molded-case circuit breakers and other safety measures to provide protection against short circuits in external wiring.
There is a risk of fire or failure.
- Always ground the Servomotor to the ground terminal on the SERVOPACK.
There is a risk of failure or malfunction.

NOTICE

- Whenever possible, use the Cables specified by Yaskawa.
If you use any other cables, confirm the rated current and application environment of your model and use the wiring materials specified by Yaskawa or equivalent materials.
- Securely tighten cable connector screws and lock mechanisms.
Insufficient tightening may result in cable connectors falling off during operation.
- Do not bundle power lines (e.g., the Main Circuit Cable) and low-current lines (e.g., the I/O Signal Cables or Encoder Cables) together or run them through the same duct. If you do not place power lines and low-current lines in separate ducts, separate them by at least 30 cm.
If the cables are too close to each other, malfunctions may occur due to noise affecting the low-current lines.
- Install a battery at either the host controller or on the Encoder Cable.
If you install batteries both at the host controller and on the Encoder Cable at the same time, you will create a loop circuit between the batteries, resulting in a risk of damage or burning.
- When connecting a battery, connect the polarity correctly.
There is a risk of battery rupture or encoder failure.

■ Maintenance and Inspection Precautions



DANGER

- Do not change any wiring while power is being supplied.
There is a risk of electric shock or injury.



WARNING

- Wiring and inspections must be performed only by qualified engineers.
There is a risk of electric shock or product failure.



CAUTION

- Wait for at least six minutes after turning OFF the power supply (with a SERVOPACK for a 100-VAC input, wait for at least nine minutes) and then make sure that the CHARGE indicator is not lit before starting wiring or inspection work. Do not touch the power supply terminals while the CHARGE lamp is lit after turning OFF the power supply because high voltage may still remain in the SERVOPACK.
There is a risk of electric shock.

■ Disposal Precautions

- Correctly discard the product as stipulated by regional, local, and municipal laws and regulations. Be sure to include these contents in all labelling and warning notifications on the final product as necessary.



■ General Precautions

- Figures provided in this document are typical examples or conceptual representations. There may be differences between them and actual wiring, circuits, and products.
- The products shown in illustrations in this document are sometimes shown without covers or protective guards. Always replace all covers and protective guards before you use the product.
- If you need a new copy of this document because it has been lost or damaged, contact your nearest Yaskawa representative or one of the offices listed on the back of this document.
- This document is subject to change without notice for product improvements, specifications changes, and improvements to the manual itself.
We will update the document number of the document and issue revisions when changes are made.
- Any and all quality guarantees provided by Yaskawa are null and void if the customer modifies the product in any way. Yaskawa disavows any responsibility for damages or losses that are caused by modified products.

Warranty

◆ Details of Warranty

■ Warranty Period

The warranty period for a product that was purchased (hereinafter called the “delivered product”) is one year from the time of delivery to the location specified by the customer or 18 months from the time of shipment from the Yaskawa factory, whichever is sooner.

■ Warranty Scope

Yaskawa shall replace or repair a defective product free of charge if a defect attributable to Yaskawa occurs during the above warranty period.

This warranty does not cover defects caused by the delivered product reaching the end of its service life and replacement of parts that require replacement or that have a limited service life.

This warranty does not cover failures that result from any of the following causes.

- Improper handling, abuse, or use in unsuitable conditions or in environments not described in product catalogs or manuals, or in any separately agreed-upon specifications
- Causes not attributable to the delivered product itself
- Modifications or repairs not performed by Yaskawa
- Use of the delivered product in a manner in which it was not originally intended
- Causes that were not foreseeable with the scientific and technological understanding at the time of shipment from Yaskawa
- Events for which Yaskawa is not responsible, such as natural or human-made disasters

◆ Limitations of Liability

- Yaskawa shall in no event be responsible for any damage or loss of opportunity to the customer that arises due to failure of the delivered product.
- Yaskawa shall not be responsible for any programs (including parameter settings) or the results of program execution of the programs provided by the user or by a third party for use with programmable Yaskawa products.
- The information described in product catalogs or manuals is provided for the purpose of the customer purchasing the appropriate product for the intended application. The use thereof does not guarantee that there are no infringements of intellectual property rights or other proprietary rights of Yaskawa or third parties, nor does it construe a license.
- Yaskawa shall not be responsible for any damage arising from infringements of intellectual property rights or other proprietary rights of third parties as a result of using the information described in catalogs or manuals.

◆ Suitability for Use

- It is the customer's responsibility to confirm conformity with any standards, codes, or regulations that apply if the Yaskawa product is used in combination with any other products.
- The customer must confirm that the Yaskawa product is suitable for the systems, machines, and equipment used by the customer.
- Consult with Yaskawa to determine whether use in the following applications is acceptable. If use in the application is acceptable, use the product with extra allowance in ratings and specifications, and provide safety measures to minimize hazards in the event of failure.
 - Outdoor use, use involving potential chemical contamination or electrical interference, or use in conditions or environments not described in product catalogs or manuals
 - Nuclear energy control systems, combustion systems, railroad systems, aviation systems, vehicle systems, medical equipment, amusement machines, and installations subject to separate industry or government regulations
 - Systems, machines, and equipment that may present a risk to life or property
 - Systems that require a high degree of reliability, such as systems that supply gas, water, or electricity, or systems that operate continuously 24 hours a day
 - Other systems that require a similar high degree of safety
- Never use the product for an application involving serious risk to life or property without first ensuring that the system is designed to secure the required level of safety with risk warnings and redundancy, and that the Yaskawa product is properly rated and installed.
- The circuit examples and other application examples described in product catalogs and manuals are for reference. Check the functionality and safety of the actual devices and equipment to be used before using the product.
- Read and understand all use prohibitions and precautions, and operate the Yaskawa product correctly to prevent accidental harm to third parties.

◆ Specifications Change

The names, specifications, appearance, and accessories of products in product catalogs and manuals may be changed at any time based on improvements and other reasons. The next editions of the revised catalogs or manuals will be published with updated code numbers. Consult with your Yaskawa representative to confirm the actual specifications before purchasing a product.

Contents

About this Manual	iii
Outline of Manual	iii
Related Documents	iv
Using This Manual	xi
Safety Precautions	xii
Warranty	xviii

1

Peripheral Devices and System Configurations

1.1	Configuration with a Rotary Servomotor	1-2
1.2	Configuration with a Direct Drive Servomotor	1-3
1.3	Configuration with a Linear Servomotor	1-4

2

Cables and User-Assembled Wiring Materials for SGM7M Rotary Servomotors

2.1	Cable Configurations	2-2
2.2	Servomotor Main Circuit Cables	2-3
2.2.1	Servomotor Main Circuit Cables for Servomotors without Holding Brakes ..	2-3
2.2.2	Servomotor Main Circuit Cables for Servomotors with Holding Brakes ...	2-4
2.3	Encoder Cables	2-5
2.3.1	Encoder Cables for Incremental Encoders	2-5
2.3.2	Encoder Cables for Absolute Encoders	2-6
2.4	User-Assembled Wiring Materials for Encoder Cables	2-7
2.4.1	Connector Kits	2-7
2.4.2	Cables without Connectors	2-8
2.5	Wiring Precautions	2-9
2.5.1	Precautions for Standard Cables	2-9
2.5.2	Precautions for Flexible Cables	2-9

3

Cables and User-Assembled Wiring Materials for SGM7J Rotary Servomotors

3.1	Cable Configurations	3-2
3.2	Servomotor Main Circuit Cables	3-3
3.2.1	Servomotor Main Circuit Cables for Servomotors without Holding Brakes ..	3-3
3.2.2	Servomotor Main Circuit Cables for Servomotors with Holding Brakes ...	3-4
3.3	User-Assembled Wiring Materials for Servomotor Main Circuit Cables ..	3-5
3.3.1	Servomotor Connector Kits	3-5
3.3.2	Cables without Connectors	3-8

3.4	Encoder Cables of 20 m or Less	3-10
3.4.1	Encoder Cables for Incremental Encoders or Batteryless Absolute Encoders . .	3-10
3.4.2	Encoder Cables for Absolute Encoders	3-11
3.5	Relay Encoder Cables of 30 m to 50 m	3-12
3.5.1	Motor-End Relay Encoder Cables	3-12
3.5.2	SERVOPACK-End Relay Encoder Cables	3-12
3.5.3	Relay Encoder Cables with Battery Cases	3-13
3.6	User-Assembled Wiring Materials for Encoder Cables	3-14
3.6.1	Precautions When Using Encoder Cables with a Wiring Length of 30 m to 50 m . .	3-14
3.6.2	SERVOPACK Connector Kits	3-14
3.6.3	Encoder Connector Kits	3-15
3.6.4	Cables without Connectors	3-16
3.7	Wiring Precautions	3-17

4

Cables and User-Assembled Wiring Materials for SGM7A Rotary Servomotors

4.1	Cable Configurations	4-3
4.1.1	SGM7A-A5 to -10 (50 W to 1.0 kW)	4-3
4.1.2	SGM7A-15 to -70 (1.5 kW to 7.0 kW)	4-4
4.2	Servomotor Main Circuit Cables	4-6
4.2.1	Servomotor Main Circuit Cables for Servomotors without Holding Brakes . .	4-6
4.2.2	Servomotor Main Circuit Cables for Servomotors with Holding Brakes	4-8
4.3	User-Assembled Wiring Materials for Servomotor Main Circuit Cables: SGM7A-A5 to -10 . .	4-12
4.3.1	Servomotor Connector Kits	4-12
4.3.2	Cables without Connectors	4-15
4.4	User-Assembled Wiring Materials for Servomotor Main Circuit Cables: SGM7A-15 to -70 . .	4-16
4.4.1	Connector Structures	4-16
4.4.2	Main Power Supply Terminal	4-17
4.4.3	Holding Brake Terminals	4-18
4.4.4	Built-in Cooling Fan Terminals	4-19
4.4.5	Connector External Dimensions	4-20
4.5	Encoder Cables of 20 m or Less	4-24
4.5.1	Encoder Cables for Incremental Encoders or Batteryless Absolute Encoders . .	4-24
4.5.2	Encoder Cables for Absolute Encoders	4-26
4.6	Relay Encoder Cable of 30 m to 50 m	4-28
4.6.1	Motor-End Relay Encoder Cables	4-28
4.6.2	SERVOPACK-End Relay Encoder Cables	4-29
4.6.3	Relay Encoder Cables with Battery Cases	4-30
4.7	User-Assembled Wiring Materials for Encoder Cables	4-31
4.7.1	Precautions When Using Encoder Cables with a Wiring Length of 30 m to 50 m . .	4-31
4.7.2	SERVOPACK Connector Kits	4-31
4.7.3	Encoder Connector Kits	4-32
4.7.4	Cables without Connectors	4-34
4.8	Wiring Precautions	4-35

5

Cables and User-Assembled Wiring Materials for SGM7P Rotary Servomotors

5.1	Cable Configurations	5-2
5.2	Servomotor Main Circuit Cables	5-4
5.2.1	Servomotor Main Circuit Cables for Servomotors without Holding Brakes . . .	5-4
5.2.2	Servomotor Main Circuit Cables for Servomotors with Holding Brakes . . .	5-5
5.3	User-Assembled Wiring Materials for Servomotor Main Circuit Cables . . .	5-6
5.3.1	Servomotor Connector Kits	5-6
5.3.2	Cables without Connectors	5-8
5.4	Encoder Cables of 20 m or Less	5-9
5.4.1	Encoder Cables for Incremental Encoders or Batteryless Absolute Encoders . . .	5-9
5.4.2	Encoder Cables for Absolute Encoders	5-11
5.5	Relay Encoder Cable of 30 m to 50 m	5-13
5.5.1	Motor-End Relay Encoder Cables	5-13
5.5.2	SERVOPACK-End Relay Encoder Cables	5-13
5.5.3	Relay Encoder Cables with Battery Cases	5-14
5.6	User-Assembled Wiring Materials for Encoder Cables	5-15
5.6.1	Precautions When Using Encoder Cables with a Wiring Length of 30 m to 50 m . . .	5-15
5.6.2	SERVOPACK Connector Kits	5-15
5.6.3	Encoder Connector Kits	5-16
5.6.4	Cables without Connectors	5-17
5.7	Wiring Precautions	5-18

6

Cables and User-Assembled Wiring Materials for SGM7G Rotary Servomotors

6.1	Cable Configurations	6-3
6.1.1	SGM7G-03 and -05 (300 W and 450 W)	6-3
6.1.2	SGM7G-09 to -1E (850 W to 15 kW)	6-4
6.2	Servomotor Main Circuit Cables	6-5
6.2.1	Servomotor Main Circuit Cables for Servomotors without Holding Brakes . . .	6-5
6.2.2	Servomotor Main Circuit Cables for Servomotors with Holding Brakes . . .	6-7
6.3	User-Assembled Wiring Materials for Servomotor Main Circuit Cables: SGM7G-03, -05 . . .	6-11
6.3.1	Servomotor Connector Kits	6-11
6.3.2	Wiring Materials	6-11
6.4	User-Assembled Wiring Materials for Servomotor Main Circuit Cables: SGM7G-09 to -1E . . .	6-12
6.4.1	Connector Structures	6-12
6.4.2	Main Power Supply Terminal	6-13
6.4.3	Holding Brake Terminals	6-14
6.4.4	Connector External Dimensions	6-16
6.5	Encoder Cables of 20 m or Less	6-20
6.5.1	Encoder Cables for Incremental Encoders or Batteryless Absolute Encoders . . .	6-20
6.5.2	Encoder Cables for Absolute Encoders	6-21

6.6	Relay Encoder Cables of 30 m to 50 m	6-22
6.6.1	Motor-End Relay Encoder Cables	6-22
6.6.2	SERVOPACK-End Relay Encoder Cables	6-22
6.6.3	Relay Encoder Cables with Battery Cases	6-23
6.7	User-Assembled Wiring Materials for Encoder Cables	6-24
6.7.1	Precautions When Using Encoder Cables with a Wiring Length of 30 m to 50 m . .	6-24
6.7.2	SERVOPACK Connector Kits	6-24
6.7.3	Encoder Connector Kits	6-25
6.7.4	Cables without Connectors	6-26
6.8	Wiring Precautions	6-27

7 Cables and User-Assembled Wiring Materials for SGMMV Rotary Servomotors

7.1	Cable Configurations	7-2
7.2	Servomotor Main Circuit Cables	7-3
7.2.1	Servomotor Main Circuit Cables for Servomotors without Holding Brakes . .	7-3
7.2.2	Servomotor Main Circuit Cables for Servomotors with Holding Brakes	7-4
7.3	Encoder Cables of 20 m or Less	7-5
7.3.1	Encoder Cables for Incremental Encoders	7-5
7.3.2	Encoder Cables for Absolute Encoders	7-6
7.4	Relay Encoder Cable of 30 m to 50 m	7-7
7.4.1	Relay Encoder Cables	7-7
7.4.2	Relay Encoder Cables with Battery Cases	7-8
7.5	User-Assembled Wiring Materials for Encoder Cables	7-9
7.5.1	Connector Kits	7-9
7.5.2	Cables without Connectors	7-10
7.6	Wiring Precautions	7-11

8 Cables and User-Assembled Wiring Materials for Direct Drive Servomotors

8.1	Cable Configurations	8-3
8.1.1	SGM7D Servomotors	8-3
8.1.2	SGM7E Motors and SGM7F-□□A to -□□D Motors	8-4
8.1.3	SGM7F-□□M and -□□N Motors and SGMCS Motors	8-5
8.1.4	SGM7F Servomotors	8-6
8.2	Servomotor Main Circuit Cables	8-7
8.2.1	SGM7D Servomotor Main Circuit Cables	8-7
8.2.2	Main Circuit Cables for SGM7E and SGM7F-□□A to -□□D Motors	8-8
8.2.3	Main Circuit Cables for SGM7F-□□M, -□□N, and SGMCS Motors	8-9
8.2.4	SGM7F Servomotor Main Circuit Cables	8-11
8.3	User-Assembled Wiring Materials for Servomotor Main Circuit Cables . .	8-12
8.3.1	Servomotor Connector Kits	8-12
8.3.2	Cables without Connectors	8-16

8.4	Encoder Cables of 20 m or Less	8-18
8.4.1	SGM7D Encoder Cables	8-18
8.4.2	Encoder Cables for SGM7E and SGM7F Servomotors	8-20
8.4.3	SGM7C Encoder Cables	8-24
8.4.4	SGM7S Encoder Cables	8-27
8.5	Relay Encoder Cable of 30 m to 50 m	8-29
8.5.1	SGM7D Encoder Cables	8-29
8.5.2	Encoder Cables for SGM7E and SGM7F Servomotors	8-31
8.5.3	SGM7C Encoder Cables	8-34
8.5.4	SGM7S Encoder Cables	8-37
8.6	User-Assembled Wiring Materials for Encoder Cables	8-39
8.6.1	SERVOPACK Connector Kits	8-39
8.6.2	Encoder Connector Kits	8-39
8.6.3	Cables without Connectors	8-40
8.7	Wiring Precautions	8-41

9

Cables and User-Assembled Wiring Materials for Linear Servomotors

9.1	Recommended Linear Encoders	9-3
9.1.1	Incremental Linear Encoders	9-3
9.1.2	Absolute Linear Encoders	9-4
9.2	Cable Configurations	9-6
9.2.1	Connections to Linear Encoder from Dr. JOHANNES HEIDENHAIN GmbH	9-6
9.2.2	Connections to Linear Encoder from RSF Elektronik GmbH	9-10
9.2.3	Connections to Linear Encoder from Renishaw plc	9-11
9.2.4	Connections to Linear Encoder from RLS d.o.o.	9-14
9.2.5	Connections to Linear Encoder from Magnescale Co., Ltd.	9-15
9.2.6	Connections to Linear Encoders from Mitutoyo Corporation	9-22
9.2.7	Connections to Linear Encoder from Fagor Automation S. Coop.	9-23
9.2.8	Connections to Linear Encoder from Canon Precision Inc.	9-24
9.3	Cable Selection Table	9-25
9.3.1	Servomotor Main Circuit Cables	9-25
9.3.2	Linear Encoder Cables	9-26
9.3.3	Serial Converter Unit Cables	9-26
9.3.4	Sensor Cables	9-27
9.3.5	Encoder Cables	9-27
9.3.6	Cable Dimensional Drawings and Wiring Specifications	9-28
9.3.7	Wiring Precautions	9-35
9.4	Serial Converter Unit	9-37
9.4.1	Selection Table	9-37
9.4.2	Characteristics and Specifications	9-38
9.4.3	External Dimensions	9-39
9.4.4	Analog Signal Input Timing	9-43

10

Cables and User-Assembled Wiring Materials for SERVOPACKs

10.1	System Configuration Diagrams and Selection Tables	10-3
10.1.1	Cable Configurations	10-3
10.1.2	Selection Table	10-6
10.2	Analog Monitor Cables	10-10
10.3	Digital Operator	10-11
10.3.1	Digital Operator for Σ -7-Series SERVOPACKs: JUSP-OP05A-1-E	10-11
10.3.2	Digital Operator Conversion Cable (for Σ -III-Series Digital Operators)	10-12
10.3.3	Digital Operator Conversion Cable with Lock Screws	10-12
10.3.4	Communications Unit	10-13
10.4	Computer Cable	10-14
10.5	I/O Signal Cables for SERVOPACKs	10-15
10.5.1	For Σ -7S Analog Voltage/Pulse Train Reference SERVOPACKs	10-15
10.5.2	For Σ -7S MECHATROLINK-II/-III Communications Reference or Command Option Attachable-Type SERVOPACKs	10-18
10.5.3	For Σ -7W SERVOPACKs	10-21
10.5.4	For Servo Section of Σ -7C SERVOPACKs	10-24
10.5.5	For Controller Section of Σ -7C SERVOPACKs	10-27
10.6	Safety Function Device Cable	10-30
10.6.1	Cables with Connectors	10-30
10.6.2	Connector Kits	10-30
10.7	MECHATROLINK-II Communications Cable	10-31
10.8	MECHATROLINK-III Communications Cable	10-32
10.9	MECHATROLINK-4 Communications Cable	10-33
10.10	Cables to Connect to MP3000/MP2000-Series Machine Controllers	10-34
10.10.1	Cables to Connect to SVA-01 Analog Output Motion Modules	10-34
10.11	I/O Signal Cables for INDEXER Modules	10-35
10.11.1	Cables with Loose Wires at One End	10-35
10.11.2	Connector Kits	10-36
10.11.3	Cables with Terminal Block on One End	10-38
10.12	Serial Command Cables (Connector Kit Only)	10-39
10.13	DeviceNet Communications Cable	10-40

11

Option Modules

11.1	Feedback Option Modules	11-2
11.1.1	Fully-Closed Modules	11-2

11.2	Safety Module	11-11
	11.2.1 Compliant Standards and Functions.	11-11
	11.2.2 Specifications.	11-12
	11.2.3 External Dimensions.	11-14
11.3	Option Case Kit	11-15

12 SERVOPACK Peripheral Devices

12.1	Molded-Case Circuit Breakers and Fuses	12-3
	12.1.1 Using an AC Power Supply.	12-3
	12.1.2 Using a DC Power Supply	12-4
12.2	Magnetic Contactors	12-6
12.3	SERVOPACK Main Circuit Wires	12-10
	12.3.1 Three-Phase, 200-VAC Wires for Σ -7S SERVOPACKs	12-10
	12.3.2 Single-Phase, 200-VAC Wires for Σ -7S SERVOPACKs	12-13
	12.3.3 Single-Phase, 100-VAC Wires for Σ -7S SERVOPACKs	12-14
	12.3.4 DC Power Supply Wires for Σ -7S SERVOPACKs	12-15
	12.3.5 Three-Phase, 200-VAC Wires for Σ -7W SERVOPACKs and Σ -7C SERVOPACKs	12-18
	12.3.6 Single-Phase, 200-VAC Wires for Σ -7W SERVOPACKs and Σ -7C SERVOPACKs	12-19
	12.3.7 DC Power Supply Wires for Σ -7W SERVOPACKs	12-19
	12.3.8 Wire Types	12-20
12.4	Crimp Terminals and Insulating Sleeves	12-21
	12.4.1 Σ -7S SERVOPACKs with Three-Phase, 200-VAC or DC Power Supplies	12-21
	12.4.2 Σ -7S SERVOPACKs with Single-Phase, 200-VAC	12-22
	12.4.3 Σ -7S SERVOPACKs with Single-Phase, 100-VAC	12-22
	12.4.4 Σ -7W SERVOPACKs with Three-Phase, 200-VAC or DC Power Supplies and Σ -7C SERVOPACKs with Three-Phase, 200-VAC	12-23
	12.4.5 Σ -7W SERVOPACKs and Σ -7C SERVOPACKs with Single-Phase, 200-VAC	12-23
12.5	Noise Filter	12-25
12.6	AC/DC Reactors	12-28
	12.6.1 Using a Three-Phase, 200-VAC Power Supply Input.	12-28
	12.6.2 Using a Single-Phase, 200-VAC Power Supply Input	12-29
	12.6.3 Using a Single-Phase, 100-VAC Power Supply Input	12-29
	12.6.4 External Dimensions.	12-30
12.7	Surge Absorbers	12-31
12.8	Regenerative Resistor	12-32
	12.8.1 Regenerative Power and Regenerative Resistance.	12-32
	12.8.2 Types of Regenerative Resistors.	12-32
	12.8.3 Selection Table	12-33
	12.8.4 Specifications of Built-in Regenerative Resistors in SERVOPACKs.	12-33
	12.8.5 Specifications and Dimensions of External Regenerative Resistors	12-34
	12.8.6 Selecting External Regenerative Resistor	12-37
12.9	Inrush Current Suppression Devices	12-53

13

Software

- 13.1 SigmaWin+: AC Servo Drive Engineering Tool13-2
- 13.2 MPE720: System Integrated Engineering Tool13-3

14

Other Peripheral Devices and Options

- 14.1 Surge Absorbers (Varistors) and Diodes for Holding Brake Power Supplies . . 14-2
- 14.2 Batteries for Servomotors with Absolute Encoders14-4
 - 14.2.1 Using Encoder Cables with Battery Cases 14-4
 - 14.2.2 When Installing a Battery on the Host Controller 14-5
- 14.3 Precautions for Connecting a Σ -V-Series Cable to a Σ -7-Series Servomotor . . 14-6
 - 14.3.1 Restrictions in Using Σ -V-Series Cables 14-6
 - 14.3.2 Precautions When the Encoder Cable Is Installed toward the Load Side . . 14-6
 - 14.3.3 Cables That Connect to Σ -7-Series Servomotors 14-7
- 14.4 Optional Metal Connectors for Servomotor Main Circuit Cables . . 14-8
 - 14.4.1 SGM7J and SGM7A (50 W to 150 W) 14-8
 - 14.4.2 SGM7J and SGM7A (200 W to 600 W) 14-8
 - 14.4.3 SGM7J and SGM7A (750 W and 1.0 kW)..... 14-9

Revision History



Peripheral Devices and System Configurations

1

- 1.1** Configuration with a Rotary Servomotor . . 1-2
- 1.2** Configuration with a Direct Drive Servomotor . . 1-3
- 1.3** Configuration with a Linear Servomotor . . . 1-4

1.1 Configuration with a Rotary Servomotor

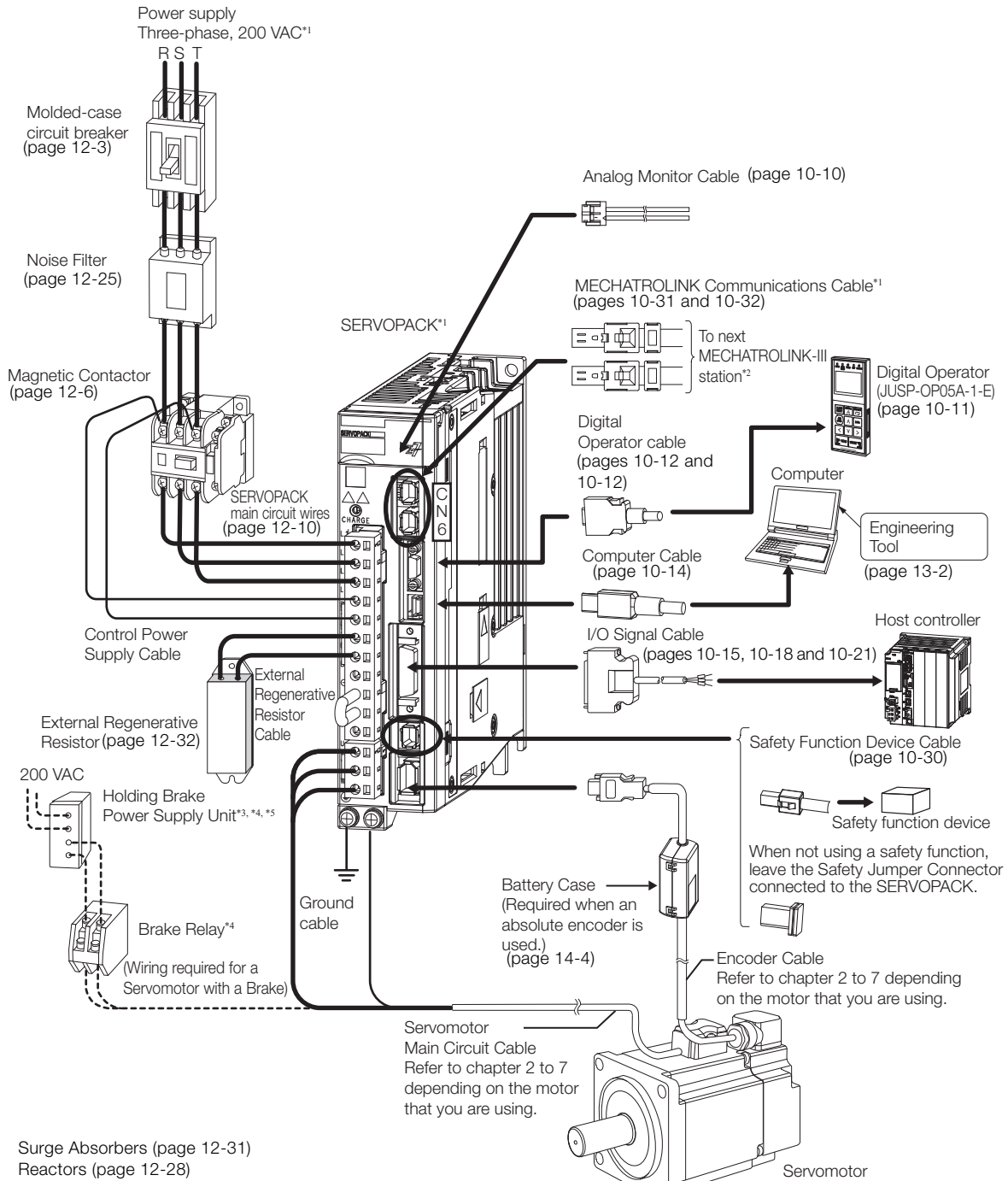

Surge Absorbers (page 12-31)

Reactors (page 12-28)

Surge Absorbers (Varistors) and Diodes for Holding Brake Power Supplies (page 14-2)

- *1. The peripheral devices are described using a MECHATROLINK-III Communications Reference SERVOPACK for a three-phase 200-VAC power supply input as an example. The shapes of the connectors and pin layout may be different for SERVOPACKs with other power supply input specifications and for other interfaces. Refer to the product manual for your SERVOPACK when using a SERVOPACK other than the above.
- *2. The connected devices depend on the interface.
 For MECHATROLINK-4 communications references: Other MECHATROLINK-4 stations
 For MECHATROLINK-II communications references: Other MECHATROLINK-II stations
 For analog voltage/pulse train references: There is no CN6 connector.
- *3. A Holding Brake Power Supply Unit is required to use a Servomotor with a Holding Brake. Holding Brake Power Supply Units for 24 VDC are not provided by Yaskawa. Obtain these from other manufacturers. Never connect Holding Brake Power Supply Units with different output voltages to a SERVOPACK. Overcurrent may result in burning in the brake.
- *4. If you use a Servomotor with a Holding Brake, select a brake relay according to the power supply voltage and current of the brake. Yaskawa does not recommend any particular brake relays. Select an appropriate brake relay using the selection method of the brake relay manufacturer.
- *5. The power supply for the holding brake is not provided by Yaskawa. Select a power supply based on the holding brake specifications. If you use a 24-V brake, install a separate power supply for the 24-VDC power supply from other power supplies, such as the one for the I/O signals of the CN1 connector. If the power supply is shared, the I/O signals may malfunction.

1.2 Configuration with a Direct Drive Servomotor

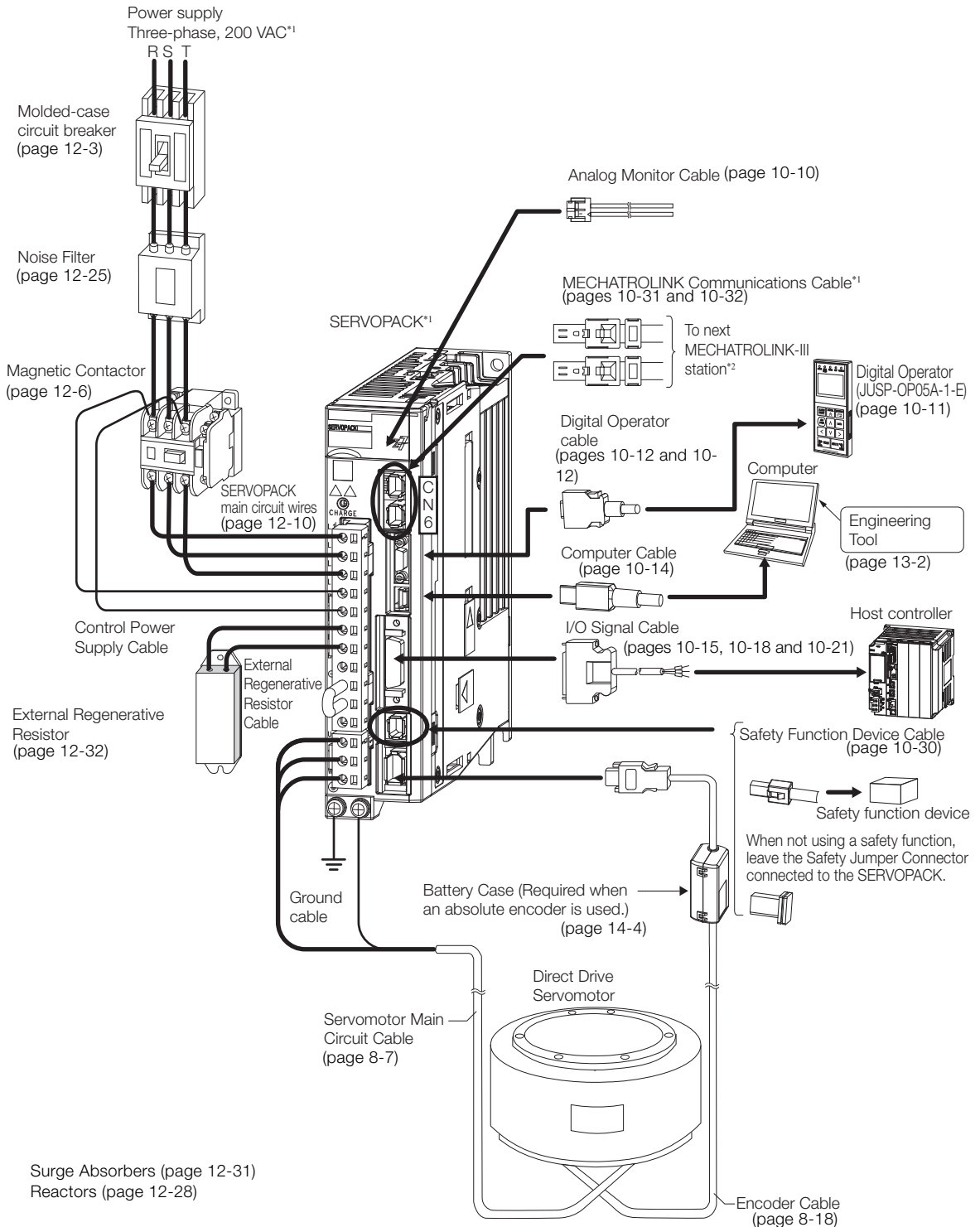

*1. The peripheral devices are described using a MECHATROLINK-III Communications Reference SERVOPACK for a three-phase 200-VAC power supply input as an example. The shapes of the connectors and pin layout may be different for SERVOPACKs with other power supply input specifications and for other interfaces. Refer to the product manual for your SERVOPACK when using a SERVOPACK other than the above.

*2. The connected devices depend on the interface.
 For MECHATROLINK-4 communications references: Other MECHATROLINK-4 stations
 For MECHATROLINK-II communications references: Other MECHATROLINK-II stations
 For analog voltage/pulse train references: There is no CN6 connector.

1.3

Configuration with a Linear Servomotor

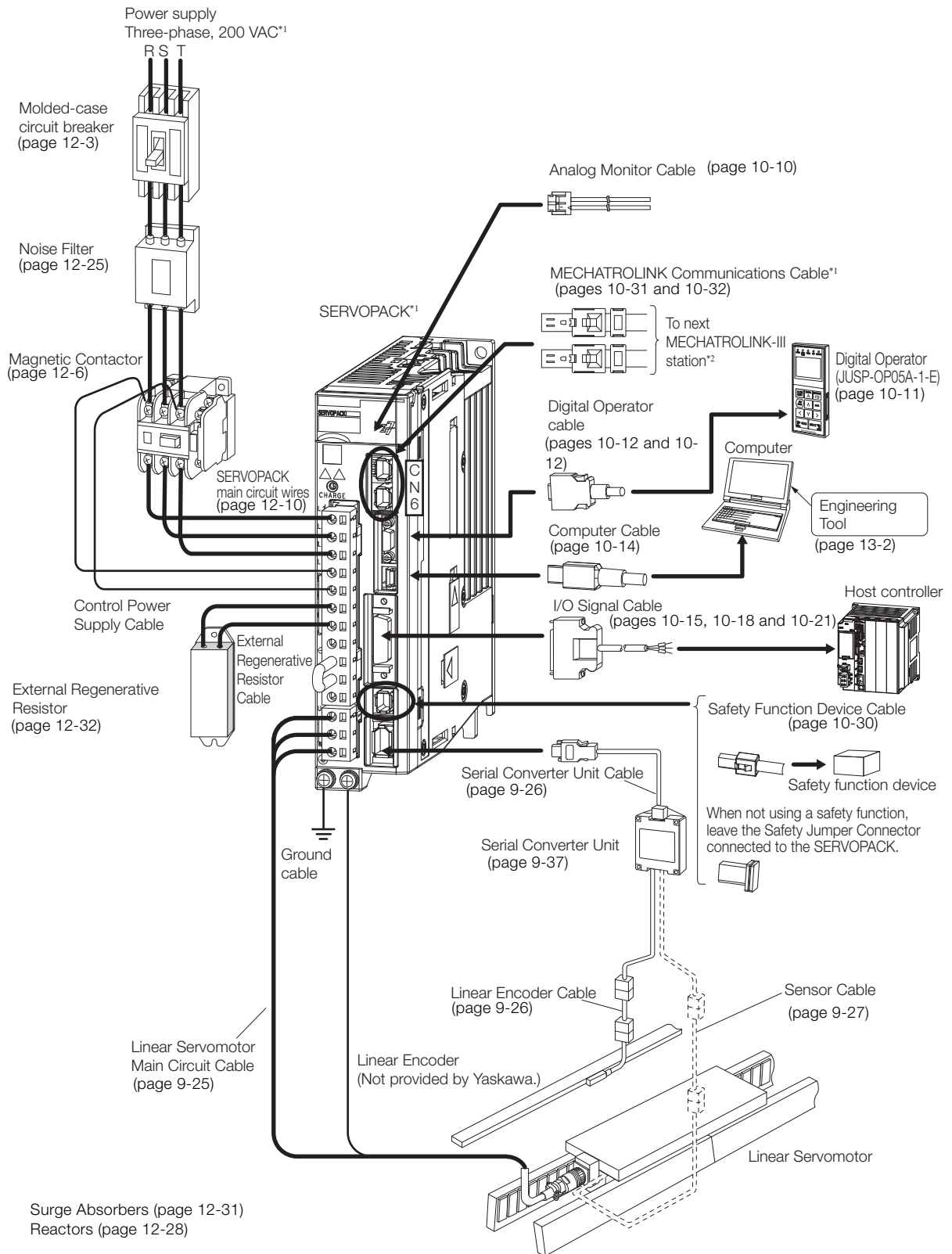

*1. The peripheral devices are described using a MECHATROLINK-III Communications Reference SERVOPACK for a three-phase 200-VAC power supply input as an example. The shapes of the connectors and pin layout may be different for SERVOPACKs with other power supply input specifications and for other interfaces. Refer to the product manual for your SERVOPACK when using a SERVOPACK other than the above.

*2. The connected devices depend on the interface.
 For MECHATROLINK-4 communications references: Other MECHATROLINK-4 stations
 For MECHATROLINK-II communications references: Other MECHATROLINK-II stations
 For analog voltage/pulse train references: There is no CN6 connector.

Cables and User-Assembled Wiring Materials for SGM7M Rotary Servomotors

2

2.1	Cable Configurations	2-2
2.2	Servomotor Main Circuit Cables	2-3
2.2.1	Servomotor Main Circuit Cables for Servomotors without Holding Brakes	2-3
2.2.2	Servomotor Main Circuit Cables for Servomotors with Holding Brakes	2-4
2.3	Encoder Cables	2-5
2.3.1	Encoder Cables for Incremental Encoders	2-5
2.3.2	Encoder Cables for Absolute Encoders	2-6
2.4	User-Assembled Wiring Materials for Encoder Cables . .	2-7
2.4.1	Connector Kits	2-7
2.4.2	Cables without Connectors	2-8
2.5	Wiring Precautions	2-9
2.5.1	Precautions for Standard Cables	2-9
2.5.2	Precautions for Flexible Cables	2-9

2.1 Cable Configurations

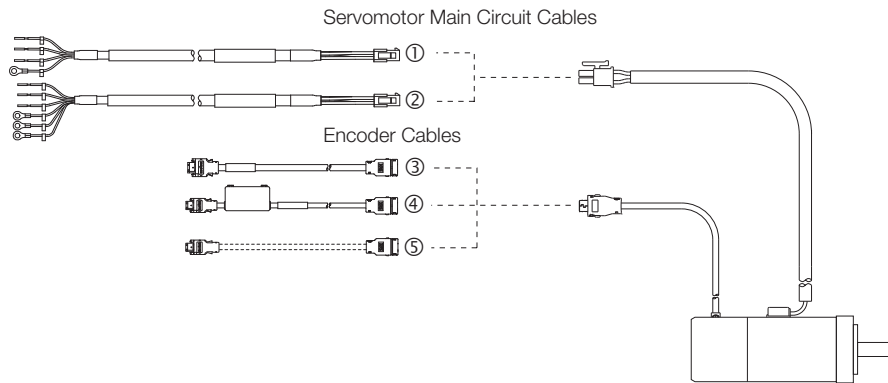

No.	Cable Type	Reference	
①	Servomotor Main Circuit Cables for Servomotors without Holding Brakes	page 2-3	
②	Servomotor Main Circuit Cables for Servomotors with Holding Brakes	page 2-4	
③	Encoder Cables for Incremental Encoders	page 2-5	
④	Encoder Cables with Battery Cases for Absolute Encoders	page 2-6	
⑤	User-Assembled Wiring Materials for Encoder Cables*	Connector Kits	page 2-7
		Cables without Connectors	page 2-8

* When you fabricate the Encoder Cable, always connect the shield wire from the Encoder Cable to the connector (shell). There is a risk of failure or malfunction.

2.2 Servomotor Main Circuit Cables

2.2.1 Servomotor Main Circuit Cables for Servomotors without Holding Brakes

Selection Table

Servomotor Model	Length (L)	Order Number ^{*1}	
		Standard Cable	Flexible Cable ^{*2, *3}
SGM7M-B3E to -B9E 3.3 W to 11 W	3 m, 5 m, 10 m, 15 m, and 20 m	JZSP-CF1M00-□□-E	JZSP-CF1M20-□□-E
SGM7M-A1E to -A3E 11 W to 33 W		JZSP-CF2M00-□□-E	JZSP-CF2M20-□□-E
SGM7M-A1A to -A3A 11 W to 33 W			

- *1. Replace the boxes (□□) in the order number with the cable length (03, 05, 10, 15, or 20).
- *2. Use Flexible Cables for moving parts of machines, such as robots.
- *3. The recommended bending radius (R) is 90 mm or larger.

Appearance

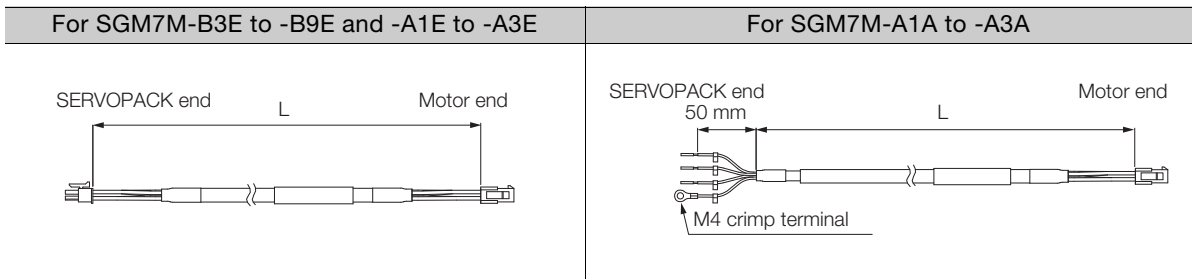

Wiring Specifications

SERVOPACK Leads		Servomotor Connector	
Wire Color	Signal	Signal	Pin
Red	Phase U	Phase U	1
White	Phase V	Phase V	2
Blue	Phase W	Phase W	3
Green/yellow	FG	FG	4

2.2.2 Servomotor Main Circuit Cables for Servomotors with Holding Brakes

Selection Table

Servomotor Model	Length (L)	Order Number*1	
		Standard Cable	Flexible Cable*2, *3
SGM7M-A1E to -A3E 11 W to 33 W	3 m, 5 m, 10 m, 15 m, and 20 m	JZSP-CF1M10-□□-E	JZSP-CF1M30-□□-E
SGM7M-A1A to -A3A 11 W to 33 W		JZSP-CF2M03-□□-E	JZSP-CF2M23-□□-E

*1. Replace the boxes (□□) in the order number with the cable length (03, 05, 10, 15, or 20).

*2. Use Flexible Cables for moving parts of machines, such as robots.

*3. The recommended bending radius (R) is 90 mm or larger.

Appearance

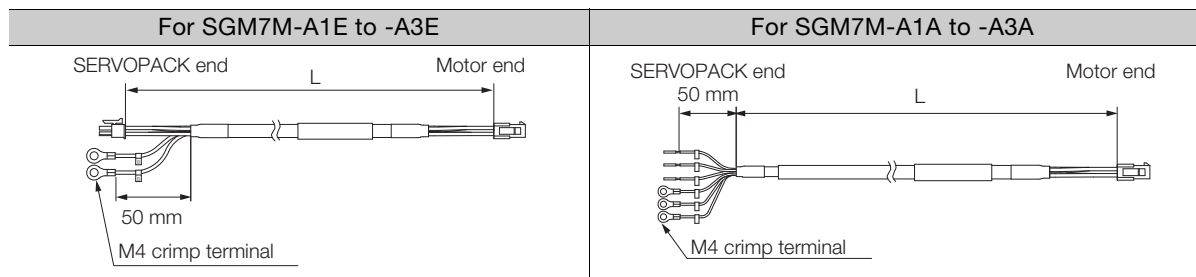

Wiring Specifications

SERVOPACK Leads		Servomotor Connector	
Wire Color	Signal	Signal	Pin
Red	Phase U	Phase U	1
White	Phase V	Phase V	2
Blue	Phase W	Phase W	3
Green/yellow	FG	FG	4
Black	Brake	Brake	5
Black	Brake	Brake	6

Note: There is no polarity for the connection to the holding brake.

2.3 Encoder Cables

2.3.1 Encoder Cables for Incremental Encoders

Selection Table

Servomotor Model	Length (L)	Order Number* ¹	
		Standard Cable	Flexible Cable* ^{2, *3}
All SGM7M models	3 m, 5 m, 10 m, 15 m, and 20 m	JZSP-C7MP01-□□-E	JZSP-C7MP21-□□-E

- *1. Replace the boxes (□□) in the order number with the cable length (03, 05, 10, 15, or 20).
- *2. Use Flexible Cables for moving parts of machines, such as robots.
- *3. The recommended bending radius (R) is 46 mm or larger.

Appearance

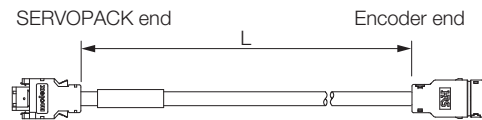

Wiring Specifications

Standard Cable					Flexible Cable										
SERVOPACK end					Encoder (motor) end		SERVOPACK end		Encoder (motor) end						
Pin	Signal				Pin	Wire Color	Pin	Signal				Pin	Wire Color		
6	/PS				6	Light blue/white	6	/PS				6	Black/pink		
5	PS				5	Light blue	5	PS				5	PS	5	Red/pink
4	BAT(-)				4	Orange/white	4	BAT(-)				4	BAT(-)	4	Black/light blue
3	BAT(+)				3	Orange	3	BAT(+)				3	BAT(+)	3	Red/light blue
2	PG 0V				2	Black	2	PG 0V				2	PG 0V	2	Light green
1	PG 5V				1	Red	1	PG 5V				1	PG 5V	1	Orange
Shell	FG	Shield wire			Shell	FG	Shell	FG	Shield wire			Shell	FG		

Cables and User-Assembled Wiring Materials for SGM7M Rotary Servomotors

2.3.2 Encoder Cables for Absolute Encoders

These cables are equipped with a Battery Case. (A Battery is included.)

Note: If a battery is connected to the host controller, the Battery Case is not required. If so, use a cable for incremental encoders.

NOTICE

- Install a battery at either the host controller or on the Encoder Cable. If you install batteries both at the host controller and on the Encoder Cable at the same time, you will create a loop circuit between the batteries, resulting in a risk of damage or burning.

Selection Table

Servomotor Model	Length (L)	Order Number*1	
		Standard Cable	Flexible Cable*2, *3
All SGM7M models	3 m, 5 m, 10 m, 15 m, and 20 m	JZSP-C7MP19-□□-E	JZSP-C7MP29-□□-E

- *1. Replace the boxes (□□) in the order number with the cable length (03, 05, 10, 15, or 20).
- *2. Use Flexible Cables for moving parts of machines, such as robots.
- *3. The recommended bending radius (R) is 46 mm or larger.

Appearance

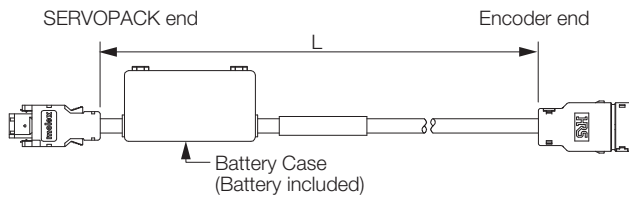

Wiring Specifications

Standard Cable				Flexible Cable				
SERVOPACK end			Encoder (motor) end		SERVOPACK end		Encoder (motor) end	
Pin	Signal		Pin	Wire Color	Pin	Signal	Pin	Wire Color
6	/PS		6	Light blue/white	6	/PS	6	Black/pink
5	PS		5	Light blue	5	PS	5	Red/pink
4	BAT(-)		4	Orange/white	4	BAT(-)	4	Black/light blue
3	BAT(+)		3	Orange	3	BAT(+)	3	Red/light blue
2	PG 0 V		2	Black	2	PG 0 V	2	Light green
1	PG 5 V		1	Red	1	PG 5 V	1	Orange
Shell	FG		Shell	FG	Shell	FG	Shell	FG
Battery Case					Battery Case			
Pin	Signal			Pin	Signal			
3	BAT(-)			3	BAT(-)			
1	BAT(+)			1	BAT(+)			

2.4 User-Assembled Wiring Materials for Encoder Cables

2.4.1 Connector Kits

SERVOPACK Connector Kits

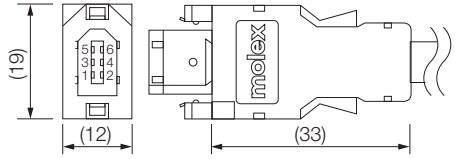
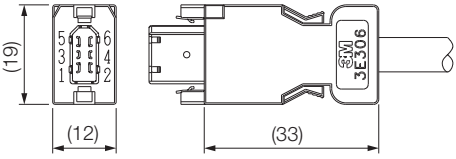
Type	Standard Cable	Compatible Connector Kit
Inquiries	Yaskawa representative	3M Japan Limited
Manufacturer	Molex Incorporated	
Order Number	JZSP-CMP9-1-E	
Specifications	55100-0670 (soldered) Product specifications: PS-54280	Receptacle: 3E206-0100 KV (soldered) Shell Kit: 3E306-3200-008 Product specifications: JNPS-1042 and JNPS-1043
External Dimensions [mm]		

Note: Cables are not included. Purchase them separately.

Encoder Connector Kits

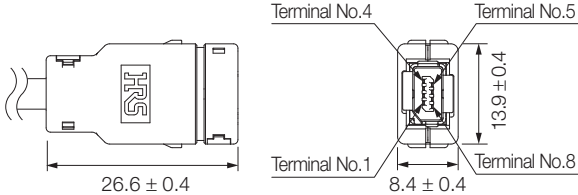
Order Number	JZSP-C7MP9-2-E
Manufacturer	Hirose Electric Co., Ltd.
Components	IX40-A-8P-JC (7.1)
Product Specifications	SLC-129407
External Dimensions [mm]	

2.4.2 Cables without Connectors

Encoder Cables

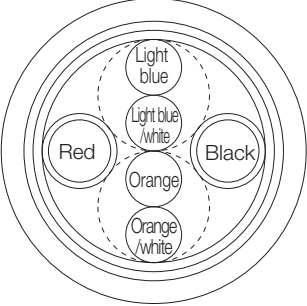
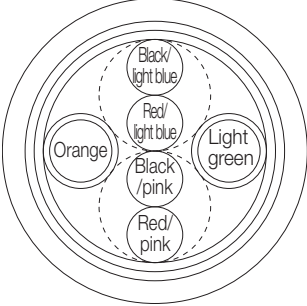
Item	Standard Cable	Flexible Cable
Order Number*	JZSP-CMP09-□□-E (maximum length: 20 m)	JZSP-CSP39-□□-E (maximum length: 20 m)
Specifications	UL20276 (rated temperature: 80°C) AWG22 × 2C + AWG24 × 2P	UL20276 (rated temperature: 80°C) AWG22 × 2C + AWG24 × 2P
	AWG22 (0.33 mm ²) Outer diameter of insulating sheath: 1.15 mm	AWG22 (0.33 mm ²) Outer diameter of insulating sheath: 1.35 mm
	AWG24 (0.20 mm ²) Outer diameter of insulating sheath: 1.09 mm	AWG24 (0.20 mm ²) Outer diameter of insulating sheath: 1.21 mm
Finished Diameter	6.5 mm	6.8 mm
Internal Structure and Lead Colors		

* Replace the boxes (□□) in the order number with the cable length (05, 10, 15, or 20).

2.5 Wiring Precautions

2.5.1 Precautions for Standard Cables

Do not use standard cables in applications that require a high degree of flexibility, such as twisting and turning, or in which the cables themselves must move. When you use Standard Cables, observe the recommended bending radius given in the following table and perform all wiring so that stress is not applied to the cables. Use the cables so that they are not repeatedly bent.

Cable Diameter	Recommended Bending Radius [R]
Less than 8 mm	15 mm min.
8 mm	20 mm min.
Over 8 mm	Cable diameter × 3 mm min.

2.5.2 Precautions for Flexible Cables

- The Flexible Cables have a service life of 10,000,000 operations minimum when used at the recommended bending radius (R) or larger under the following test conditions. The service life of a Flexible Cable is reference data under the following test conditions. The service life of a Flexible Cable greatly depends on the amount of mechanical shock, how the cable is attached, and how the cable is secured.

<Test Conditions>

- One end of the cable is repeatedly moved forward and backward for 320 mm using the test equipment shown in the following figure.
- The lead wires are connected in series, and the number of cable return operations until a lead wire breaks are counted. One round trip is counted as one bend.

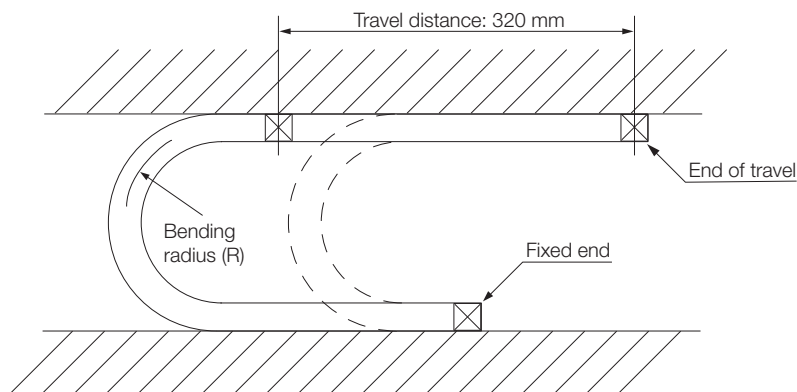

Note: The service life of a Flexible Cable indicates the number of bends while the lead wires are electrically charged for which no cracks or damage that affect the performance of the cable sheathing occurs. Breaking of the shield wire is not considered.

- Straighten out the Flexible Cable when you connect it. If the cable is connected while it is twisted, it will break faster. Check the indication on the cable surface to make sure that the cable is not twisted.
- Do not secure the portions of the Flexible Cable that move. Stress will accumulate at the point that is secured, and the cable will break faster. Secure the cable in as few locations as possible.
- If a Flexible Cable is too long, looseness will cause it to break faster. If the Flexible Cable is too short, stress at the points where it is secured will cause it to break faster. Adjust the cable length to the optimum value.
- Do not allow Flexible Cables to interfere with each other. Interference will restrict the motion of the cables, causing them to break faster. Separate the cables sufficiently, or provide partitions between them when wiring.

2.5 Wiring Precautions

2.5.2 Precautions for Flexible Cables

Cables and User-Assembled Wiring Materials for SGM7J Rotary Servomotors

3

3.1	Cable Configurations	3-2
3.2	Servomotor Main Circuit Cables	3-3
3.2.1	Servomotor Main Circuit Cables for Servomotors without Holding Brakes	3-3
3.2.2	Servomotor Main Circuit Cables for Servomotors with Holding Brakes	3-4
3.3	User-Assembled Wiring Materials for Servomotor Main Circuit Cables . .	3-5
3.3.1	Servomotor Connector Kits	3-5
3.3.2	Cables without Connectors	3-8
3.4	Encoder Cables of 20 m or Less	3-10
3.4.1	Encoder Cables for Incremental Encoders or Batteryless Absolute Encoders	3-10
3.4.2	Encoder Cables for Absolute Encoders	3-11
3.5	Relay Encoder Cables of 30 m to 50 m . . .	3-12
3.5.1	Motor-End Relay Encoder Cables	3-12
3.5.2	SERVOPACK-End Relay Encoder Cables	3-12
3.5.3	Relay Encoder Cables with Battery Cases	3-13
3.6	User-Assembled Wiring Materials for Encoder Cables . .	3-14
3.6.1	Precautions When Using Encoder Cables with a Wiring Length of 30 m to 50 m	3-14
3.6.2	SERVOPACK Connector Kits	3-14
3.6.3	Encoder Connector Kits	3-15
3.6.4	Cables without Connectors	3-16
3.7	Wiring Precautions	3-17

3.1 Cable Configurations

There are different order numbers for the Servomotor Main Circuit Cables and Encoder Cables depending on the cable installation direction. Confirm the order numbers before you order.

- Cable Installed toward Load

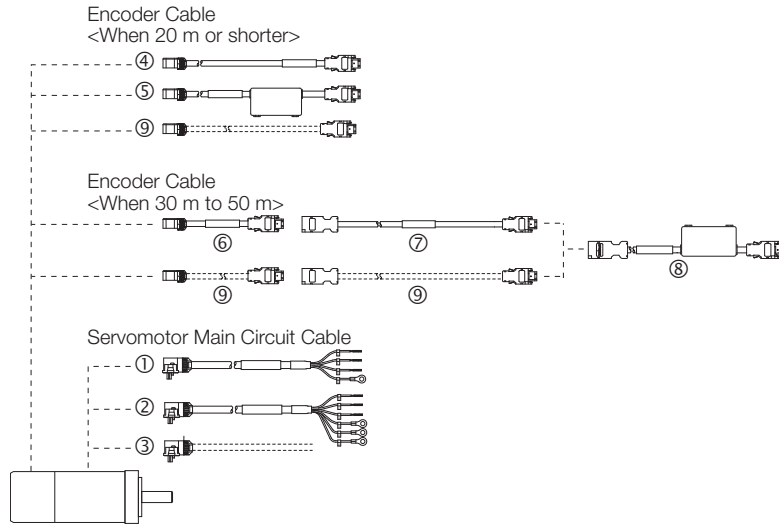

- Cable Installed away from Load

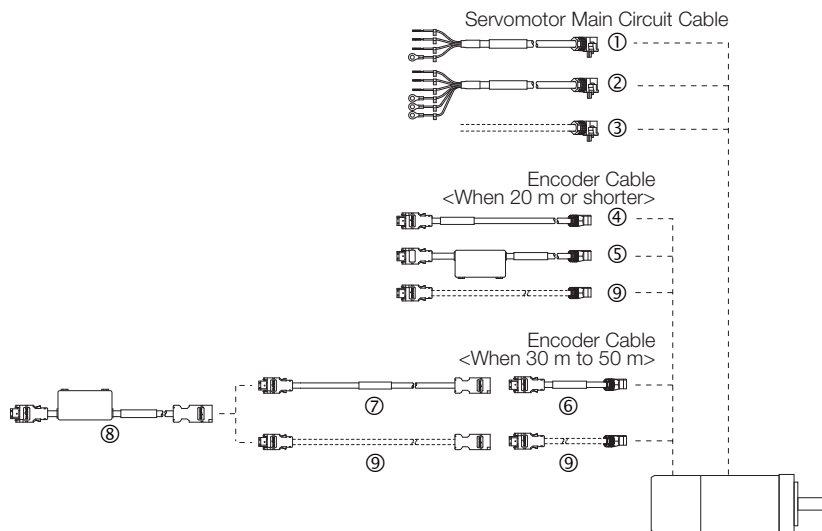

Note: If the Encoder Cable length exceeds 20 m, be sure to also connect Relay Encoder Cables as shown at ⑥ to ⑧ in the above diagram.

No.	Cable Type		Reference
①	Servomotor Main Circuit Cable	For Servomotors without Holding Brakes	page 3-3
②		For Servomotors with Holding Brakes	page 3-4
③	User-Assembled Wiring Materials for Servomotor Main Circuit Cables	Connector Kits	page 3-5
		Cables without Connectors	page 3-8
④	Encoder Cables of 20 m or Less for Incremental Encoders or Batteryless Absolute Encoders		page 3-10
⑤	Encoder Cables of 20 m or Less with Battery Cases for Absolute Encoders*1		page 3-11
⑥	Motor-End Relay Encoder Cables		page 3-12
⑦	SERVOPACK-End Relay Encoder Cables		
⑧	Relay Encoder Cables with Battery Cases*2		
⑨	User-Assembled Wiring Materials for Encoder Cables*3	Connector Kits	page 3-14
		Cables without Connectors	page 3-15

*1. If a battery is connected to the host controller, the Battery Case is not required. Use an Encoder Cable for Incremental Encoders or Batteryless Absolute Encoders.
 *2. This Cable is not required if you use a Servomotor with an Incremental Encoder, use a Servomotor with a Batteryless Absolute Encoder, or connect a battery to the host controller.
 *3. When you fabricate the Encoder Cable, always connect the shield wire from the Encoder Cable to the connector (shell). There is a risk of failure or malfunction.

3.2 Servomotor Main Circuit Cables

3.2.1 Servomotor Main Circuit Cables for Servomotors without Holding Brakes

Selection Table

Cable Direction	Servomotor Model	Length (L)	Order Number* ¹	
			Standard Cable	Flexible Cable* ^{2, *3}
Load side	SGM7J-A5 to -C2 50 W to 150 W	3 m, 5 m, 10 m, 15 m, 20 m, 30 m, 40 m, and 50 m	JZSP-C7M10F-□□-E	JZSP-C7M12F-□□-E
	SGM7J-02 to -06 200 W to 600 W		JZSP-C7M20F-□□-E	JZSP-C7M22F-□□-E
	SGM7J-08 750 W		JZSP-C7M30F-□□-E	JZSP-C7M32F-□□-E
Non-load side	SGM7J-A5 to -C2 50 W to 150 W		JZSP-C7M10G-□□-E	JZSP-C7M12G-□□-E
	SGM7J-02 to -06 200 W to 600 W		JZSP-C7M20G-□□-E	JZSP-C7M22G-□□-E
	SGM7J-08 750 W		JZSP-C7M30G-□□-E	JZSP-C7M32G-□□-E

*1. Replace the boxes (□□) in the order number with the cable length (03, 05, 10, 15, 20, 30, 40, or 50).

*2. Use Flexible Cables for moving parts of machines, such as robots.

*3. The recommended bending radius (R) is 90 mm or larger.

Note: If the length of the Servomotor Main Circuit Cable exceeds 20 m, the intermittent duty zone in the torque-motor speed characteristics will become smaller because the voltage drop increases.

Appearance

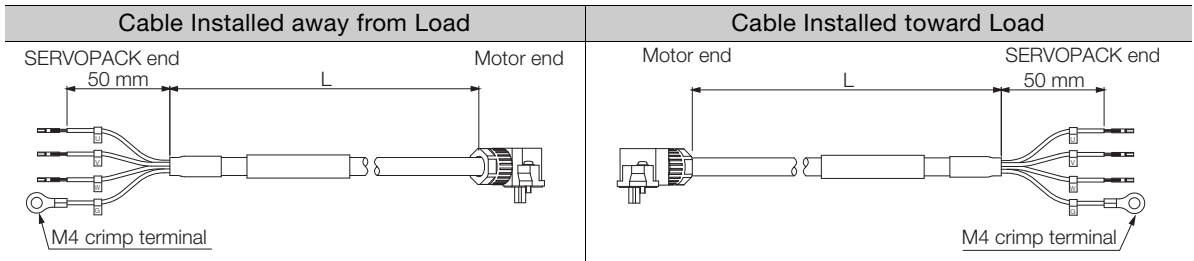

Wiring Specifications

SERVOPACK Leads		Servomotor Connector	
Wire Color	Signal	Signal	Pin
Green/yellow	FG	FG	1
Blue	Phase W	Phase W	2
White	Phase V	Phase V	3
Red	Phase U	Phase U	4
		-	5
		-	6

Cables and User-Assembled Wiring Materials for SGM7J Rotary Servomotors

3.2.2 Servomotor Main Circuit Cables for Servomotors with Holding Brakes

Selection Table

Cable Direction	Servomotor Model	Length (L)	Order Number ^{*1}	
			Standard Cable	Flexible Cable ^{*2, *3}
Load side	SGM7J-A5 to -C2 50 W to 150 W	3 m, 5 m, 10 m, 15 m, 20 m, 30 m, 40 m, and 50 m	JZSP-C7M13F-□□-E	JZSP-C7M14F-□□-E
	SGM7J-02 to -06 200 W to 600 W		JZSP-C7M23F-□□-E	JZSP-C7M24F-□□-E
	SGM7J-08 750 W		JZSP-C7M33F-□□-E	JZSP-C7M34F-□□-E
Non-load side	SGM7J-A5 to -C2 50 W to 150 W		JZSP-C7M13G-□□-E	JZSP-C7M14G-□□-E
	SGM7J-02 to -06 200 W to 600 W		JZSP-C7M23G-□□-E	JZSP-C7M24G-□□-E
	SGM7J-08 750 W		JZSP-C7M33G-□□-E	JZSP-C7M34G-□□-E

*1. Replace the boxes (□□) in the order number with the cable length (03, 05, 10, 15, 20, 30, 40, or 50).

*2. Use Flexible Cables for moving parts of machines, such as robots.

*3. The recommended bending radius (R) is 90 mm or larger.

Note: If the length of the Servomotor Main Circuit Cable exceeds 20 m, the intermittent duty zone in the torque-motor speed characteristics will become smaller because the voltage drop increases.

Appearance

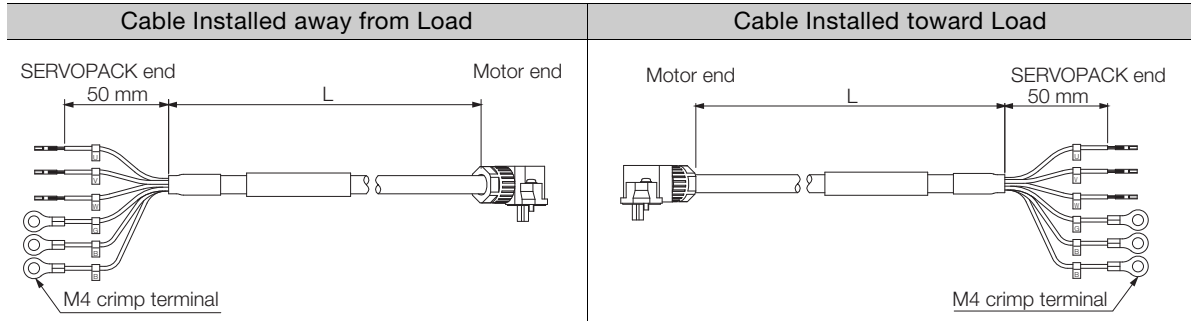

Wiring Specifications

SERVOPACK Leads		Servomotor Connector	
Wire Color	Signal	Signal	Pin
Green/yellow	FG	FG	1
Blue	Phase W	Phase W	2
White	Phase V	Phase V	3
Red	Phase U	Phase U	4
Black	Brake	Brake	5
Black	Brake	Brake	6

Note: There is no polarity for the connection to the holding brake.

3.3

User-Assembled Wiring Materials for Servomotor Main Circuit Cables

3.3.1 Servomotor Connector Kits

Selection Table

Servomotor Model	Servomotor Capacity	Order Number*
SGM7J-A5 to -C2	50 W to 150 W	JZSP-C7M9-1-E
SGM7J-02 to -06	200 W to 600 W	JZSP-C7M9-2-E
SGM7J-08	750 W	JZSP-C7M9-3-E

* Cables are not included. Purchase them separately.

◆ SGM7J-A5 to -C2 (for 50 W to 150 W)

Item	Description
Order Number	JZSP-C7M9-1-E
Manufacturer	J.S.T. Mfg. Co., Ltd.
User Instructions	JFA Connector J-1700
Components	Receptacle
	Contacts
	J17S-06FMH-7KL-M-CF SJ1F-01GF-P0.8
Applicable Wire Sizes	Power terminals: AWG20 Holding brake terminals: AWG20 to AWG24
Applicable Cable Diameter	7 mm ±0.3 mm
Outer Diameter of Insulating Sheath	1.11 mm to 1.53 mm
Mounting Screws	M2 pan-head screws
Crimping Tool*	Hand Tool
	Applicator
	YRS-8841 APLMK SJ1F/M01-08

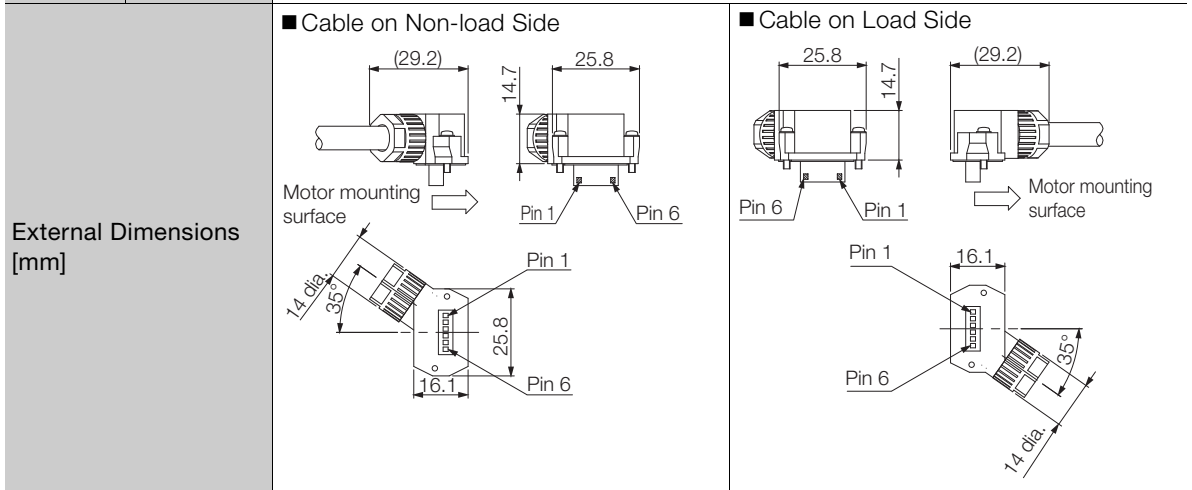

* A Crimping Tool is required. Contact the connector manufacturer for details.

3.3.1 Servomotor Connector Kits

◆ SGM7J-02 to -06 (for 200 W to 600 W)

Item		Description
Order Number		JZSP-C7M9-2-E
Manufacturer		J.S.T. Mfg. Co., Ltd.
User Instructions		JFA Connector J-2700
Compo- nents	Receptacle	J27S-06FMH-7KL-M-CF
	Contacts	SJ2F-01GF-P1.0
Applicable Wire Sizes		Power terminals: AWG20 Holding brake terminals: AWG20 to AWG24
Applicable Cable Diameter		7 mm ±0.3 mm
Outer Diameter of Insulating Sheath		1.11 mm to 1.53 mm
Mounting Screws		M2 pan-head screws
Crimp- ing Tool*	Hand Tool	YRS-8861
	Applicator	APLMK SJ2F/M01-10
External Dimensions [mm]	<p>■ Cable on Non-load Side</p>	<p>■ Cable on Load Side</p>

* A Crimping Tool is required. Contact the connector manufacturer for details.

◆ SGM7J-08 (for 750 W)

Item		Description
Order Number		JZSP-C7M9-3-E
Manufacturer		J.S.T. Mfg. Co., Ltd.
User Instructions		JFA Connector J-3700
Components	Receptacle	J37S-06FMH-8KL-M-CF
	Contacts	Power terminals: SJ3F-41GF-P1.8 Holding brake terminals: SJ3F-01GF-P1.8
Applicable Wire Sizes		Power terminals: AWG16 Holding brake terminals: AWG20 to AWG24
Applicable Cable Diameter		8 mm ±0.3 mm
Outer Diameter of Insulating Sheath		Power terminals: 1.53 mm to 2.5 mm Holding brake terminals: 1.11 mm to 1.86 mm
Mounting Screws		M2.5 pan-head screws
Crimping Tool*	Hand Tool	Power terminals: YRF-880 Holding brake terminals: YRF-881
	Applicator	Power terminals: APLMK SJ3F/M41-20 Holding brake terminals: APLMK SJ3F/M01-20
External Dimensions [mm]		<div style="display: flex; justify-content: space-between;"> <div style="width: 48%;"> <p>■ Cable on Non-load Side</p> </div> <div style="width: 48%;"> <p>■ Cable on Load Side</p> </div> </div>

* A Crimping Tool is required. Contact the connector manufacturer for details.

3.3.2 Cables without Connectors

Selection Table

Servomotor Model	Servomotor Capacity	Order Number* ¹	
		Standard Cable	Flexible Cable* ^{2, *3}
SGM7J-A5 to -C2	50 W to 600 W	JZSP-CSM90-□□-E	JZSP-C7M29-□□-E
SGM7J-02 to -06			
SGM7J-08	750 W	JZSP-CSM91-□□-E	JZSP-CSM81-□□-E

*1. Replace the boxes (□□) in the order number with the cable length (05, 10, 15, 20, 30, 40, or 50).

*2. Use Flexible Cables for moving parts of machines, such as robots.

*3. The recommended bending radius (R) is 90 mm or larger.

Note: If the length of the Servomotor Main Circuit Cable exceeds 20 m, the intermittent duty zone in the torque-motor speed characteristics will become smaller because the voltage drop increases.

◆ SGM7J-A5 to -06 (for 50 W to 600 W)

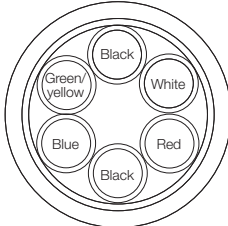
Item	Standard Cable	Flexible Cable
Order Number*	JZSP-CSM90-□□-E (maximum length: 50 m)	JZSP-C7M29-□□-E (maximum length: 50 m)
Specifications	UL2517 (rated temperature:105°C) AWG20 × 6C	UL2517 (rated temperature:105°C) AWG20 × 4C, AWG22 × 2C
	Power lines: AWG20 (0.52 mm ²) Outer diameter of insulating sheath: 1.53 mm	Power lines: AWG20 (0.52 mm ²) Outer diameter of insulating sheath: 1.37 mm
	Holding brake lines: AWG20 (0.52 mm ²) Outer diameter of insulating sheath: 1.53 mm	Holding brake lines: AWG22 (0.33 mm ²) Outer diameter of insulating sheath: 1.37 mm
Finished Diameter	7 mm ±0.3 mm	
Internal Structure and Lead Colors		

* Replace the boxes (□□) in the order number with the cable length (05, 10, 15, 20, 30, 40, or 50).

◆ SGM7J-08 (for 750 W)

Item	Standard Cable	Flexible Cable
Order Number*	JZSP-CSM91-□□-E (maximum length: 50 m)	JZSP-CSM81-□□-E (maximum length: 50 m)
Specifications	UL2517 (rated temperature:105°C) AWG16 × 4C, AWG20 × 2C	UL2517 (rated temperature:105°C) AWG16 × 4C, AWG22 × 2C
	Power lines: AWG16 (1.31 mm ²) Outer diameter of insulating sheath: 2.15 mm	Power lines: AWG16 (1.31 mm ²) Outer diameter of insulating sheath: 2.35 mm
	Holding brake lines: AWG20 (0.52 mm ²) Outer diameter of insulating sheath: 1.6 mm	Holding brake lines: AWG22 (0.33 mm ²) Outer diameter of insulating sheath: 1.37 mm
Finished Diameter	8 mm ±0.3 mm	
Internal Structure and Lead Colors		

* Replace the boxes (□□) in the order number with the cable length (05, 10, 15, 20, 30, 40, or 50).

3.4 Encoder Cables of 20 m or Less

3.4.1 Encoder Cables for Incremental Encoders or Batteryless Absolute Encoders

Selection Table

Cable Direction	Servomotor Model	Length (L)	Order Number* ¹	
			Standard Cable	Flexible Cable* ^{2, *3}
Load side	All SGM7J models	3 m, 5 m, 10 m, 15 m, and 20 m	JZSP-C7PI0D-□□-E	JZSP-C7PI2D-□□-E
Non-load side			JZSP-C7PI0E-□□-E	JZSP-C7PI2E-□□-E

- *1. Replace the boxes (□□) in the order number with the cable length (03, 05, 10, 15, or 20).
- *2. Use Flexible Cables for moving parts of machines, such as robots.
- *3. The recommended bending radius (R) is 46 mm or larger.

Appearance

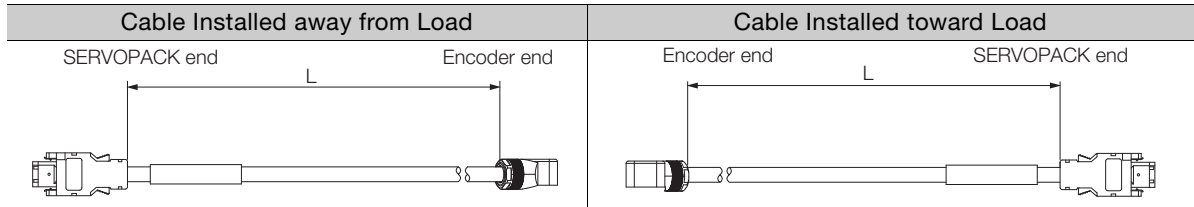

Wiring Specifications

Standard Cable					Flexible Cable				
SERVOPACK end			Encoder (motor) end		SERVOPACK end			Encoder (motor) end	
Pin	Signal		Pin	Wire Color	Pin	Signal	Pin	Wire Color	
6	/PS		5	Light blue/white	6	/PS	5	Black/pink	
5	PS		4	Light blue	5	PS	4	Red/pink	
4	BAT (-)		8	Orange/white	4	BAT (-)	8	Black/light blue	
3	BAT (+)		9	Orange	3	BAT (+)	9	Red/light blue	
2	PG 0 V		3	Black	2	PG 0 V	3	Light green	
1	PG 5 V		6	Red	1	PG 5 V	6	Orange	
Shell	FG	Shield wire	Shell	FG	Shell	FG	Shell	FG	

3.4.2 Encoder Cables for Absolute Encoders

These cables are equipped with a Battery Case. (A Battery is included.)

Note: If a battery is connected to the host controller, the Battery Case is not required. Use an Encoder Cable for Incremental Encoders or Batteryless Absolute Encoders.

NOTICE

- Install a battery at either the host controller or on the Encoder Cable. If you install batteries both at the host controller and on the Encoder Cable at the same time, you will create a loop circuit between the batteries, resulting in a risk of damage or burning.

Selection Table

Cable Direction	Servomotor Model	Length (L)	Order Number* ¹	
			Standard Cable	Flexible Cable* ^{2, *3}
Load side	All SGM7J models	3 m, 5 m, 10 m, 15 m, and 20 m	JZSP-C7PA0D-□□-E	JZSP-C7PA2D-□□-E
Non-load side			JZSP-C7PA0E-□□-E	JZSP-C7PA2E-□□-E

- *1. Replace the boxes (□□) in the order number with the cable length (03, 05, 10, 15, or 20).
- *2. Use Flexible Cables for moving parts of machines, such as robots.
- *3. The recommended bending radius (R) is 46 mm or larger.

Appearance

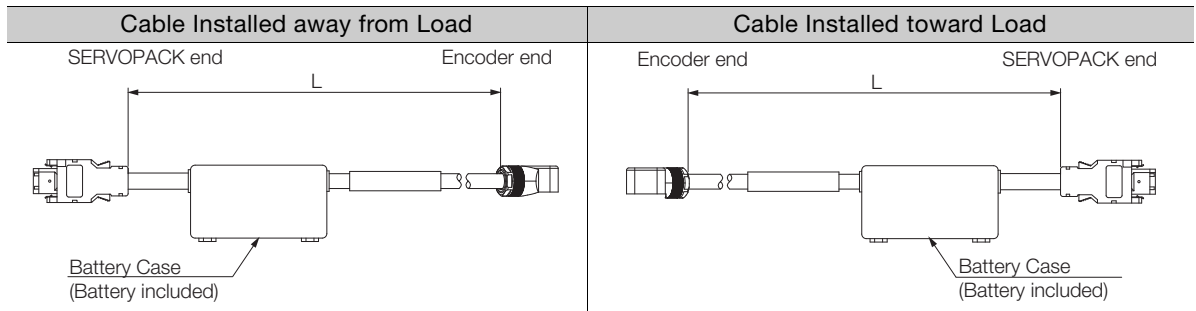

Wiring Specifications

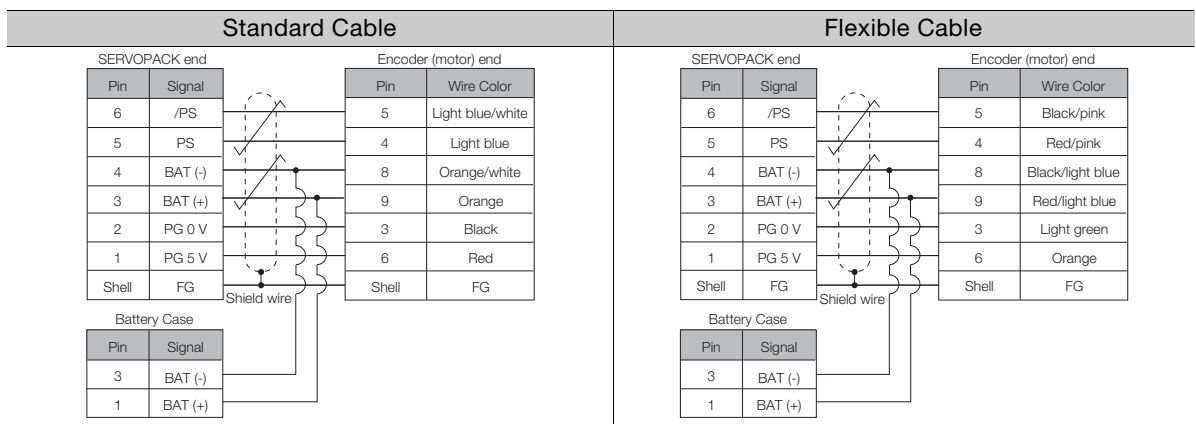

3.5 Relay Encoder Cables of 30 m to 50 m

If the Encoder Cable length exceeds 20 m, be sure to also use a Motor-End Relay Encoder Cable and a SERVOPACK-End Relay Encoder Cable.

If you use a motor with an absolute encoder and a battery is not mounted to the host controller, also obtain a Relay Encoder Cable with a Battery Case in addition to the above two Cables.

NOTICE

- Install a battery at either the host controller or on the Encoder Cable.
If you install batteries both at the host controller and on the Encoder Cable at the same time, you will create a loop circuit between the batteries, resulting in a risk of damage or burning.

3.5.1 Motor-End Relay Encoder Cables

Selection Table

Cable Direction	Specification	Length (L)	Order Number
Load side	Used for all types of encoders.	0.3 m	JZSP-C7PRCD-E
Non-load side			JZSP-C7PRCE-E

Appearance

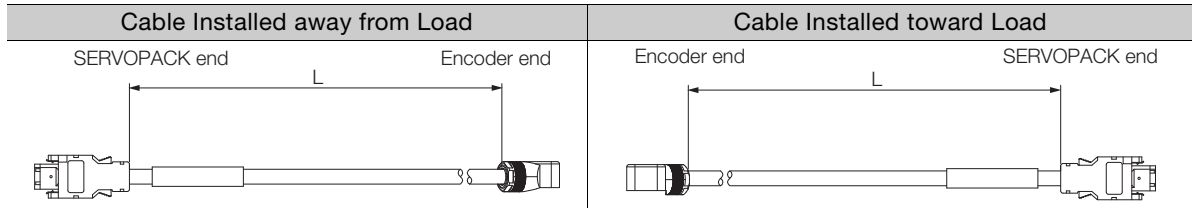

Wiring Specifications

SERVOPACK end		Encoder (motor) end	
Pin	Signal	Pin	Wire Color
6	/PS	5	Light blue/white
5	PS	4	Light blue
4	BAT (-)	8	Orange/white
3	BAT (+)	9	Orange
2	PG 0 V	3	Black
1	PG 5 V	6	Red
Shell	FG	Shell	FG

Shield wire

3.5.2 SERVOPACK-End Relay Encoder Cables

Selection Table

Specification	Length (L)	Order Number*
Used for all types of encoders.	30 m, 40 m, and 50 m	JZSP-UCMP00-□□-E

* Replace the boxes (□□) in the order number with the cable length (30, 40, or 50).

Appearance

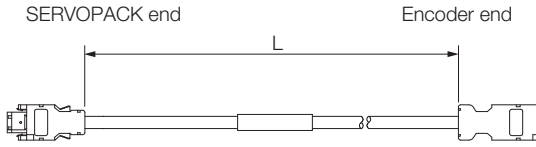

Wiring Specifications

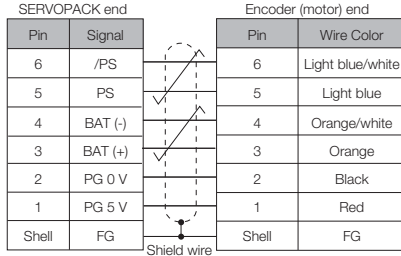

3.5.3 Relay Encoder Cables with Battery Cases

Note: This Cable is not required if you use a Servomotor with an Incremental Encoder, use a Servomotor with a Batteryless Absolute Encoder, or connect a battery to the host controller.

Selection Table

Length (L)	Order Number
0.3 m	JZSP-CSP12-E

Appearance

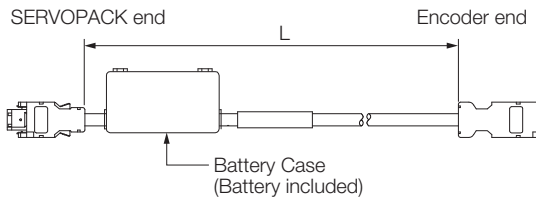

Wiring Specifications

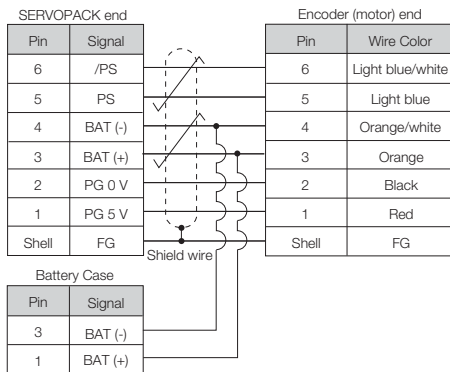

3.6 User-Assembled Wiring Materials for Encoder Cables

3.6.1 Precautions When Using Encoder Cables with a Wiring Length of 30 m to 50 m

When using Encoder Cables with a wiring length of 30 m to 50 m, it is necessary to fabricate two different types of cables.

Cables to be Fabricated	Connectors and Wire Materials Required for Fabrication	Reference Page	Remarks
Motor-End Relay Encoder Cable	SERVOPACK Connector	3.6.2 <i>SERVOPACK Connector Kits</i> on page 3-14	This cable should be 0.3 m or less.
	Servomotor Connector	3.6.3 <i>Encoder Connector Kits</i> on page 3-15	
	Encoder Cable (20 m or less)	3.6.4 <i>Cables without Connectors</i> on page 3-16	
SERVOPACK-End Relay Encoder Cable	SERVOPACK Connector	3.6.2 <i>SERVOPACK Connector Kits</i> on page 3-14	This cable should be 50 m or less.
	Cable Relay Connector	3.6.3 <i>Encoder Connector Kits</i> on page 3-15	
	Relay Encoder Cable (30 m to 50 m)	3.6.4 <i>Cables without Connectors</i> on page 3-16	

Refer to the following section for details on the connection of the Relay Encoder Cable.

 3.1 *Cable Configurations* on page 3-2

3.6.2 SERVOPACK Connector Kits

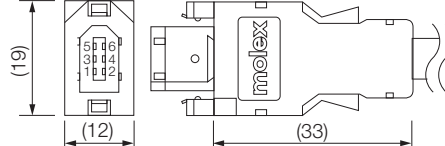
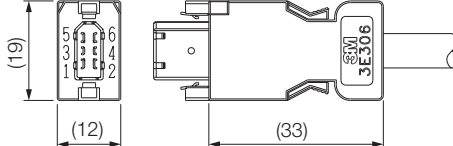
Type	Standard Connector Kit	Compatible Connector Kit
Inquires	Yaskawa representative	3M Japan Limited
Manufacturer	Molex Incorporated	
Order Number	JZSP-CMP9-1-E	
Specifications	55100-0670 (soldered) Product specifications: PS-54280	Receptacle: 3E206-0100 KV (soldered) Shell Kit: 3E306-3200-008 Product specifications: JNPS-1042 and JNPS-1043
External Dimensions [mm]		

Note: Cables are not included. Purchase them separately.

3.6.3 Encoder Connector Kits

◆ Servomotor Connectors

Order Number	JZSP-C7P9-1-E	
Manufacturer	Molex Incorporated	
Components	504678-0070 Loose Connectors: 56161-8181 (crimped), Reeled: 56161-8081 (crimped)	
Applicable Wire Sizes	AWG22 to AWG26	
Applicable Cable Diameter	6.3 mm to 7.7 mm	
Outer Diameter of Insulating Sheath	1.05 mm to 1.4 mm	
Mounting Screws	M2 pan-head screws (two)	
Application Specifications	AS-504682	
Crimping Specifications	CS-56161	
Crimping Tool*	Hand Tool	57175-5000
Shell Caulking Tool	57331-5100	
External Dimensions [mm]	<p>■ Cable Installed away from Load</p>	<p>■ Cable Installed toward Load</p>

* A Crimping Tool is required. When using other wire sizes, contact the connector manufacturer for crimping tools.

Note: Cables are not included. Purchase them separately.

◆ Cable Relay Connectors

Order Number	JZSP-CMP9-2-E
Manufacturer	Molex Incorporated
Components	54280-0609 (soldered)
Product Specifications	PS-54280
External Dimensions [mm]	

3.6.4 Cables without Connectors

Encoder Cables of 20 m or Less

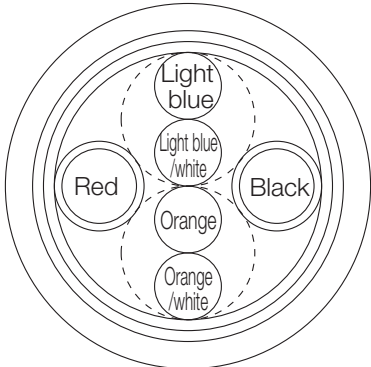
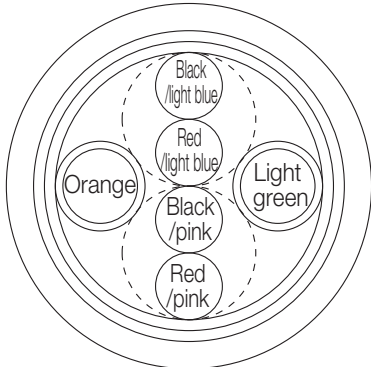
Item	Standard Cable	Flexible Cable
Order Number*	JZSP-CMP09-□□-E (maximum length: 20 m)	JZSP-CSP39-□□-E (maximum length: 20 m)
Specifications	UL20276 (rated temperature: 80°C) AWG22 × 2C + AWG24 × 2P	UL20276 (rated temperature: 80°C) AWG22 × 2C + AWG24 × 2P
	AWG22 (0.33 mm ²) Outer diameter of insulating sheath: 1.15 mm	AWG22 (0.33 mm ²) Outer diameter of insulating sheath: 1.35 mm
	AWG24 (0.20 mm ²) Outer diameter of insulating sheath: 1.09 mm	AWG24 (0.20 mm ²) Outer diameter of insulating sheath: 1.21 mm
Finished Diameter	6.5 mm	6.8 mm
Internal Structure and Lead Colors		

* Replace the boxes (□□) in the order number with the cable length (05, 10, 15, or 20).

Relay Encoder Cable of 30 m to 50 m

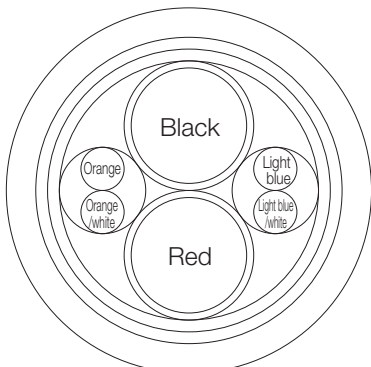
Item	Standard Cable
Order Number*	JZSP-CMP19-□□-E (maximum length: 50 m)
Specifications	UL20276 (rated temperature: 80°C) AWG16 × 2C + AWG26 × 2P
	AWG16 (1.31 mm ²) Outer diameter of insulating sheath: 2.0 mm
	AWG26 (0.13 mm ²) Outer diameter of insulating sheath: 0.91 mm
Finished Diameter	6.8 mm
Internal Structure and Lead Colors	

* Replace the boxes (□□) in the order number with the cable length (30, 40, or 50).

3.7 Wiring Precautions

The wiring precautions are the same as for SGM7M Rotary Servomotors. Refer to the following section.

 2.5 *Wiring Precautions* on page 2-9

Cables and User-Assembled Wiring Materials for SGM7A Rotary Servomotors

4

4.1 Cable Configurations 4-3

- 4.1.1 SGM7A-A5 to -10 (50 W to 1.0 kW) 4-3
- 4.1.2 SGM7A-15 to -70 (1.5 kW to 7.0 kW) 4-4

4.2 Servomotor Main Circuit Cables 4-6

- 4.2.1 Servomotor Main Circuit Cables for Servomotors without Holding Brakes 4-6
- 4.2.2 Servomotor Main Circuit Cables for Servomotors with Holding Brakes 4-8

4.3 User-Assembled Wiring Materials for Servomotor Main Circuit Cables: SGM7A-A5 to -10 . . 4-12

- 4.3.1 Servomotor Connector Kits 4-12
- 4.3.2 Cables without Connectors 4-15

4.4 User-Assembled Wiring Materials for Servomotor Main Circuit Cables: SGM7A-15 to -70 . . 4-16

- 4.4.1 Connector Structures 4-16
- 4.4.2 Main Power Supply Terminal 4-17
- 4.4.3 Holding Brake Terminals 4-18
- 4.4.4 Built-in Cooling Fan Terminals 4-19
- 4.4.5 Connector External Dimensions 4-20

4.5 Encoder Cables of 20 m or Less 4-24

- 4.5.1 Encoder Cables for Incremental Encoders or Batteryless Absolute Encoders 4-24
- 4.5.2 Encoder Cables for Absolute Encoders 4-26

4.6 Relay Encoder Cable of 30 m to 50 m 4-28

- 4.6.1 Motor-End Relay Encoder Cables 4-28
- 4.6.2 SERVOPACK-End Relay Encoder Cables 4-29
- 4.6.3 Relay Encoder Cables with Battery Cases 4-30

4.7	User-Assembled Wiring Materials for Encoder Cables . .	4-31
4.7.1	Precautions When Using Encoder Cables with a Wiring Length of 30 m to 50 m	4-31
4.7.2	SERVOPACK Connector Kits	4-31
4.7.3	Encoder Connector Kits	4-32
4.7.4	Cables without Connectors	4-34
4.8	Wiring Precautions	4-35

4.1 Cable Configurations

4.1.1 SGM7A-A5 to -10 (50 W to 1.0 kW)

There are different order numbers for the Servomotor Main Circuit Cables and Encoder Cables depending on the cable installation direction. Confirm the order numbers before you order.

- Cable Installed toward Load

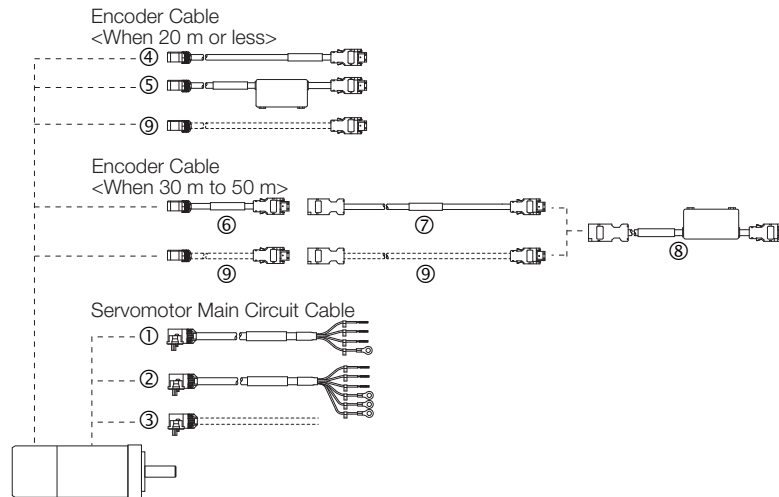

- Cable Installed away from Load

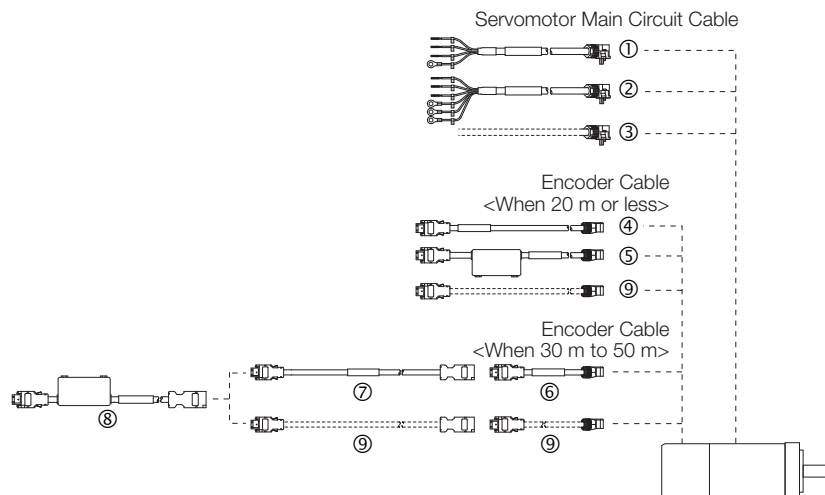

Note: If the Encoder Cable length exceeds 20 m, be sure to also connect Relay Encoder Cables as shown at ⑦ to ⑨ in the above diagram.

No.	Cable Type	Reference
①	Servomotor Main Circuit Cables	For Servomotors without Holding Brakes
②		For Servomotors with Holding Brakes
③	User-Assembled Wiring Materials for Servomotor Main Circuit Cables	Connector Kits
		Cables without Connectors
④	Encoder Cables of 20 m or Less for Incremental Encoders or Batteryless Absolute Encoders	page 4-24
⑤	Encoder Cables of 20 m or Less with Battery Cases for Absolute Encoders* ¹	page 4-26
⑥	Motor-End Relay Encoder Cables	page 4-28
⑦	SERVOPACK-End Relay Encoder Cables	
⑧	Relay Encoder Cables with Battery Cases* ²	
⑨	User-Assembled Wiring Materials for Encoder Cables* ³	Connector Kits
		Cables without Connectors

*1. If a battery is connected to the host controller, the Battery Case is not required. Use an Encoder Cable for Incremental Encoders or Batteryless Absolute Encoders.

*2. This Cable is not required if you use a Servomotor with an Incremental Encoder, use a Servomotor with a Batteryless Absolute Encoder, or connect a battery to the host controller.

*3. When you fabricate the Encoder Cable, always connect the shield wire from the Encoder Cable to the connector (shell). There is a risk of failure or malfunction.

4.1.2 SGM7A-15 to -70 (1.5 kW to 7.0 kW)

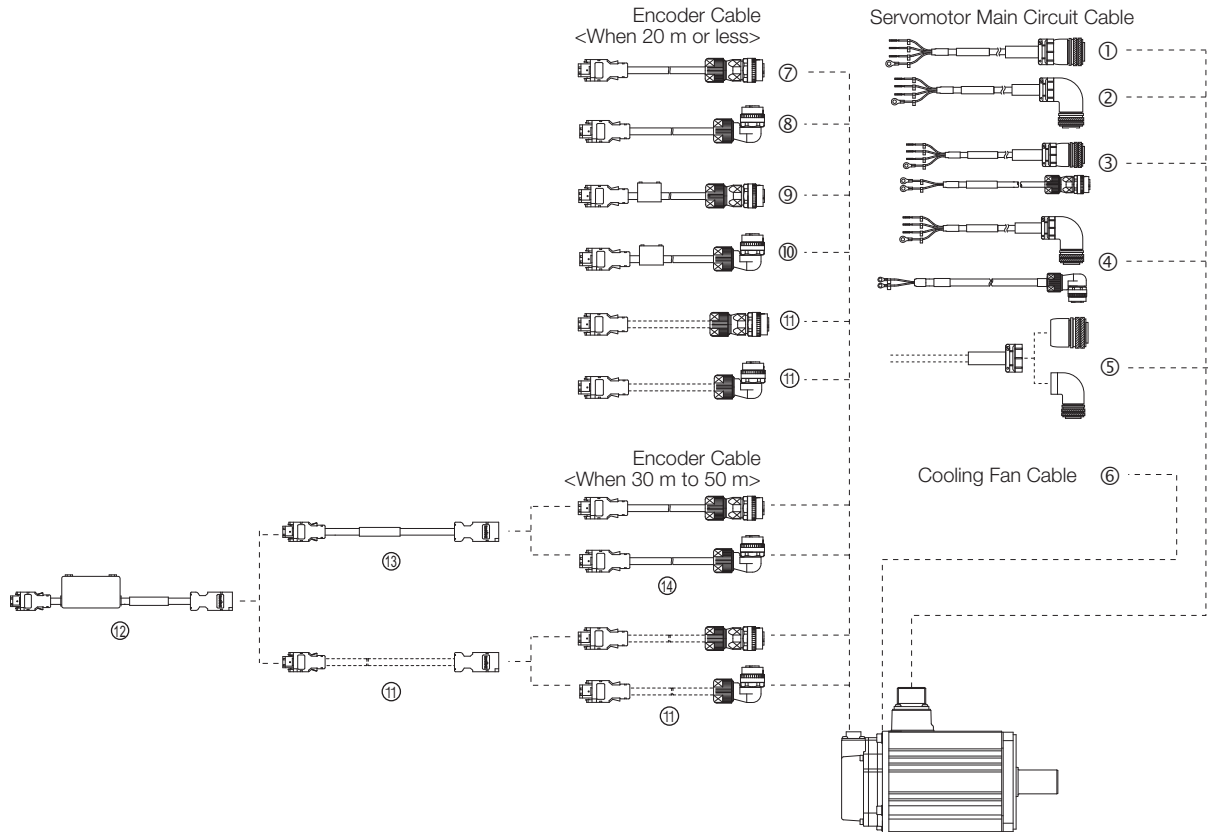

Note: If the Encoder Cable length exceeds 20 m, be sure to also connect Relay Encoder Cables as shown at ⑪ to ⑭ in the above diagram.

No.	Cable Type	Reference	
①	Servomotor Main Circuit Cables for Servomotors without Holding Brakes*1	Straight Plug	page 4-6
②			
③	Servomotor Main Circuit Cables for Servomotors with Holding Brakes*1	Straight Plug	page 4-8
④			
⑤	User-Assembled Wiring Materials for Servomotor Main Circuit Cables	Connectors	page 4-16
		Cables without Connectors*3	-
⑥	Cooling Fan Cable*4		page 4-19
⑦	Encoder Cables of 20 m or Less for Incremental Encoders or Batteryless Absolute Encoders	Straight Plug	page 4-25
⑧		Right-Angle Plug	
⑨	Encoder Cables of 20 m or Less with Battery Cases for Absolute Encoders*5	Straight Plug	page 4-27
⑩		Right-Angle Plug	
⑪	User-Assembled Wiring Materials for Encoder Cables*6	Connectors	page 4-31
		Cables without Connectors	page 4-34
⑫	Relay Encoder Cables with Battery Cases*7		page 4-29
⑬	SERVOPACK-End Relay Encoder Cables		
⑭	Motor-End Relay Encoder Cables		

*1. Cables with connectors on both ends that are compliant with an IP67 protective structure and European Safety Standards are not available from Yaskawa. Fabricate the cables by yourself or consult your Yaskawa representative. To fabricate the cables, refer to the following section.

4.4 User-Assembled Wiring Materials for Servomotor Main Circuit Cables: SGM7A-15 to -70 on page 4-16

*2. The lead installation direction is away from the load. Consult your Yaskawa representative for other lead installation directions.

*3. Yaskawa does not specify what wiring materials to use for the Servomotor Main Circuit Cables. Use appropriate wiring materials for the current specifications and connectors.

*4. A cooling fan is built into the SGM7A-70 Servomotor only. There is no specified cable to connect to the built-in cooling fan connector. Use appropriate wiring materials for the built-in cooling fan connector specifications.

*5. If a battery is connected to the host controller, the Battery Case is not required. Use an Encoder Cable for Incremental Encoders or Batteryless Absolute Encoders.

- *6. When you fabricate the Encoder Cable, always connect the shield wire from the Encoder Cable to the connector (shell). There is a risk of failure or malfunction.
- *7. This Cable is not required if you use a Servomotor with an Incremental Encoder, use a Servomotor with a Batteryless Absolute Encoder, or connect a battery to the host controller.

4.2 Servomotor Main Circuit Cables

4.2.1 Servomotor Main Circuit Cables for Servomotors without Holding Brakes

Selection Table

◆ SGM7A-A5 to -10 (50 W to 1.0 kW)

Cable Direction	Servomotor Model	Length (L)	Order Number* ¹	
			Standard Cable	Flexible Cable* ^{2, *3}
Load side	SGM7A-A5 to -C2 50 W to 150 W	3 m, 5 m, 10 m, 15 m, 20 m, 30 m, 40 m, and 50 m	JZSP-C7M10F-□□-E	JZSP-C7M12F-□□-E
	SGM7A-02 to -06 200 W to 600 W		JZSP-C7M20F-□□-E	JZSP-C7M22F-□□-E
	SGM7A-08 or -10 750 W or 1.0 kW		JZSP-C7M30F-□□-E	JZSP-C7M32F-□□-E
Non-load side	SGM7A-A5 to -C2 50 W to 150 W		JZSP-C7M10G-□□-E	JZSP-C7M12G-□□-E
	SGM7A-02 to -06 200 W to 600 W		JZSP-C7M20G-□□-E	JZSP-C7M22G-□□-E
	SGM7A-08 or -10 750 W or 1.0 kW		JZSP-C7M30G-□□-E	JZSP-C7M32G-□□-E

*1. Replace the boxes (□□) in the order number with the cable length (03, 05, 10, 15, 20, 30, 40, or 50).

*2. Use Flexible Cables for moving parts of machines, such as robots.

*3. The recommended bending radius (R) is 90 mm or larger.

Note: If the length of the Servomotor Main Circuit Cable exceeds 20 m, the intermittent duty zone in the torque-motor speed characteristics will become smaller because the voltage drop increases.

◆ SGM7A-15 to -70 (1.5 kW to 7.0 kW)

Note: Cables with connectors on both ends that are compliant with an IP67 protective structure and European Safety Standards are not available from Yaskawa. Fabricate the cables by yourself or consult your Yaskawa representative.

To fabricate the cables, refer to the following section.

 4.4 User-Assembled Wiring Materials for Servomotor Main Circuit Cables: SGM7A-15 to -70 on page 4-16

Servomotor Model	Connector Specifications	Length (L)	Order Number* ¹	
			Standard Cable	Flexible Cable* ^{2, *3}
SGM7A-15 1.5 kW	Straight	3 m, 5 m, 10 m, 15 m, and 20 m	JZSP-UVA101-□□-E	JZSP-UVA121-□□-E
	Right-angle* ⁴		JZSP-UVA102-□□-E	JZSP-UVA122-□□-E
SGM7A-20 2.0 kW	Straight		JZSP-UVA301-□□-E	JZSP-UVA321-□□-E
	Right-angle* ⁴		JZSP-UVA302-□□-E	JZSP-UVA322-□□-E
SGM7A-25 2.5 kW	Straight		JZSP-UVA501-□□-E	JZSP-UVA521-□□-E
	Right-angle* ⁴		JZSP-UVA502-□□-E	JZSP-UVA522-□□-E
SGM7A-30 3.0 kW	Straight		JZSP-UVA601-□□-E	JZSP-UVA621-□□-E
	Right-angle* ⁴		JZSP-UVA602-□□-E	JZSP-UVA622-□□-E
SGM7A-40 or -50 4.0 kW or 5.0 kW	Straight		JZSP-UVA701-□□-E	JZSP-UVA721-□□-E
	Right-angle* ⁴		JZSP-UVA702-□□-E	JZSP-UVA722-□□-E
SGM7A-70* ⁵ 7.0 kW	Straight		JZSP-UVA901-□□-E	JZSP-UVA921-□□-E
	Right-angle* ⁴		JZSP-UVA902-□□-E	JZSP-UVA922-□□-E

*1. Replace the boxes (□□) in the order number with the cable length (03, 05, 10, 15, or 20).

*2. Use Flexible Cables for moving parts of machines, such as robots.

*3. The recommended bending radius (R) is 90 mm or larger.

*4. The lead installation direction is away from the load. Consult your Yaskawa representative for other lead installation directions.

4.2.1 Servomotor Main Circuit Cables for Servomotors without Holding Brakes

*5. A cooling fan is built into the SGM7A-70 Servomotor only. Cooling fan cables are not available. Fabricate the cables by yourself or consult your Yaskawa representative.
Refer to the following section for the built-in cooling fan connector specifications that are required to select the cable.

🔗 4.4.4 Built-in Cooling Fan Terminals on page 4-19

Appearance

◆ SGM7A-A5 to -10 (50 W to 1.0 kW)

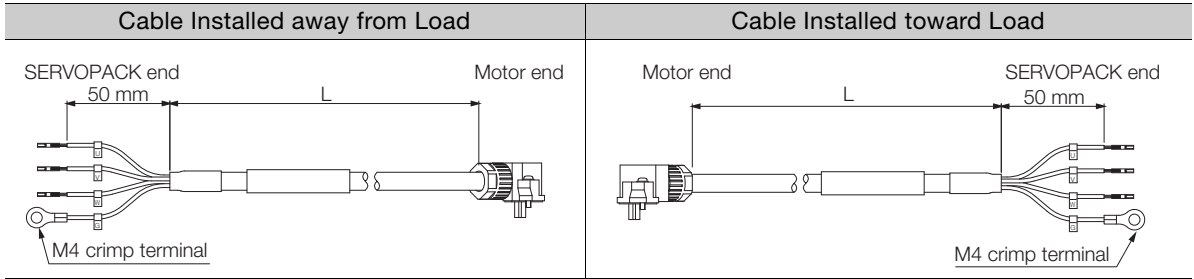

◆ SGM7A-15 to -70 (1.5 kW to 7.0 kW)

Note: Cables with connectors on both ends that are compliant with an IP67 protective structure and European Safety Standards are not available from Yaskawa. Fabricate the cables by yourself or consult your Yaskawa representative.

To fabricate the cables, refer to the following section.

🔗 4.4 User-Assembled Wiring Materials for Servomotor Main Circuit Cables: SGM7A-15 to -70 on page 4-16

Servomotor Model	Straight Connector	Right-Angle Connector*
SGM7A-15 1.5 kW		
SGM7A-20 to -70 2.0 kW to 7.0 kW		

* The lead installation direction is away from the load. Consult your Yaskawa representative for other lead installation directions.

Wiring Specifications

SGM7A-A5 to -10 (50 W to 1.0 kW)				SGM7A-15 to -70 (1.5 kW to 7.0 kW)			
SERVOPACK Leads		Servomotor Connector		SERVOPACK Leads		Servomotor Connector	
Wire Color	Signal	Signal	Pin	Wire Color	Signal	Signal	Pin
Green/yellow	FG	FG	1	Red	Phase U	Phase U	A
Blue	Phase W	Phase W	2	White	Phase V	Phase V	B
White	Phase V	Phase V	3	Black or blue	Phase W	Phase W	C
Red	Phase U	Phase U	4	Green or green/yellow	FG	FG	D
		-	5				
		-	6				

4.2.2 Servomotor Main Circuit Cables for Servomotors with Holding Brakes

Selection Table

◆ SGM7A-A5 to -10 (50 W to 1.0 kW)

Cable Direction	Servomotor Model	Length (L)	Order Number ^{*1}	
			Standard Cable	Flexible Cable ^{*2, *3}
Load side	SGM7A-A5 to -C2 50 W to 150 W	3 m, 5 m, 10 m, 15 m, 20 m, 30 m, 40 m, and 50 m	JZSP-C7M13F-□□-E	JZSP-C7M14F-□□-E
	SGM7A-02 to -06 200 W to 600 W		JZSP-C7M23F-□□-E	JZSP-C7M24F-□□-E
	SGM7A-08 or -10 750 W or 1.0 kW		JZSP-C7M33F-□□-E	JZSP-C7M34F-□□-E
Non-load side	SGM7A-A5 to -C2 50 W to 150 W		JZSP-C7M13G-□□-E	JZSP-C7M14G-□□-E
	SGM7A-02 to -06 200 W to 600 W		JZSP-C7M23G-□□-E	JZSP-C7M24G-□□-E
	SGM7A-08 or -10 750 W or 1.0 kW		JZSP-C7M33G-□□-E	JZSP-C7M34G-□□-E

*1. Replace the boxes (□□) in the order number with the cable length (03, 05, 10, 15, 20, 30, 40, or 50).

*2. Use Flexible Cables for moving parts of machines, such as robots.

*3. The recommended bending radius (R) is 90 mm or larger.

Note: If the length of the Servomotor Main Circuit Cable exceeds 20 m, the intermittent duty zone in the torque-motor speed characteristics will become smaller because the voltage drop increases.

◆ SGM7A-15 to -50 (1.5 kW to 5.0 kW)

Note: Cables with connectors on both ends that are compliant with an IP67 protective structure and European Safety Standards are not available from Yaskawa. Fabricate the cables by yourself or consult your Yaskawa representative.

To fabricate the cables, refer to the following section.

 **4.4 User-Assembled Wiring Materials for Servomotor Main Circuit Cables: SGM7A-15 to -70 on page 4-16**

Servomotor Model	Connector Specifications	Length (L)	Order Number ^{*1, *2}	
			Set of Two Cables (Main Power Supply Cable and Holding Brake Cable)	
			Standard Cable	Flexible Cable ^{*3, *4}
SGM7A-15 1.5 kW	Straight	3 m, 5 m, 10 m, 15 m, and 20 m	JZSP-UVA131-□□-E	JZSP-UVA141-□□-E
	Right-angle ^{*5}		JZSP-UVA132-□□-E	JZSP-UVA142-□□-E
SGM7A-20 2.0 kW	Straight		JZSP-UVA331-□□-E	JZSP-UVA341-□□-E
	Right-angle ^{*5}		JZSP-UVA332-□□-E	JZSP-UVA342-□□-E
SGM7A-25 2.5 kW	Straight		JZSP-U7A551-□□-E	JZSP-U7A561-□□-E
	Right-angle ^{*5}		JZSP-U7A552-□□-E	JZSP-U7A562-□□-E
SGM7A-30 3.0 kW	Straight		JZSP-UVA631-□□-E	JZSP-UVA641-□□-E
	Right-angle ^{*5}		JZSP-UVA632-□□-E	JZSP-UVA642-□□-E
SGM7A-40 or -50 4.0 kW or 5.0 kW	Straight		JZSP-UVA731-□□-E	JZSP-UVA741-□□-E
	Right-angle ^{*5}		JZSP-UVA732-□□-E	JZSP-UVA742-□□-E

*1. Replace the boxes (□□) in the order number with the cable length (03, 05, 10, 15, or 20).

*2. Refer to the following section to obtain Main Circuit Power Supply Cables and Holding Brake Cables individually.

 **Appearance on page 4-9**

*3. Use Flexible Cables for moving parts of machines, such as robots.

*4. The recommended bending radius (R) is 90 mm or larger.

*5. The lead installation direction is away from the load. Consult your Yaskawa representative for other lead installation directions.

Appearance

◆ SGM7A-A5 to -10 (50 W to 1.0 kW)

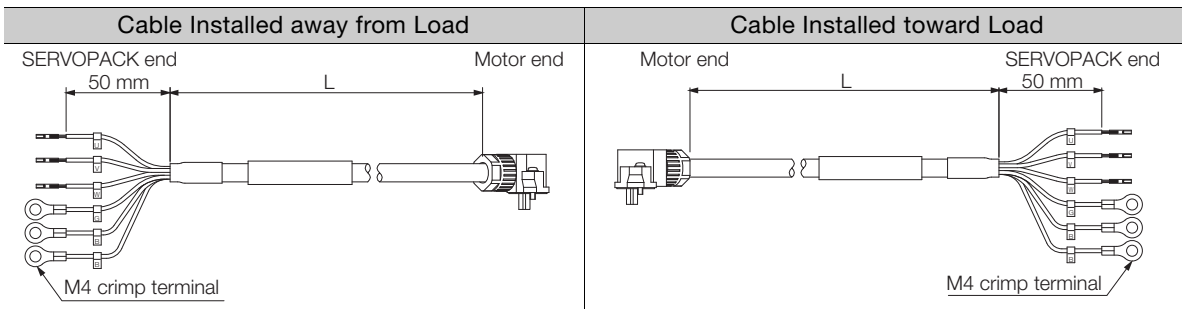

◆ SGM7A-15 to -50 (for 1.5 kW to 5.0 kW)

Servomotor Model	Connector Type	Appearance	Order Numbers of Main Power Supply Cable and Holding Brake Cable	Individual Cable Order Numbers
SGM7A-15 1.5 kW	Straight		Standard Cable: JZSP-UVA131-□□-E Flexible Cable: JZSP-UVA141-□□-E	<ul style="list-style-type: none"> Main Circuit Power Supply Cable Standard Cable: JZSP-UVA101-□□-E Flexible Cable: JZSP-UVA121-□□-E Holding Brake Cable*² JZSP-U7B23-□□-E
	Right-angle* ¹		Standard Cable: JZSP-UVA132-□□-E Flexible Cable: JZSP-UVA142-□□-E	<ul style="list-style-type: none"> Main Circuit Power Supply Cable Standard Cable: JZSP-UVA102-□□-E Flexible Cable: JZSP-UVA122-□□-E Holding Brake Cable*² JZSP-U7B24-□□-E

Continued on next page.

*1. The lead installation direction is away from the load. Consult your Yaskawa representative for other lead installation directions.

*2. Flexible Cables are provided as a standard feature.

4.2 Servomotor Main Circuit Cables

4.2.2 Servomotor Main Circuit Cables for Servomotors with Holding Brakes

Continued from previous page.

Servomotor Model	Connector Type	Appearance	Order Numbers of Main Power Supply Cable and Holding Brake Cable	Individual Cable Order Numbers
SGM7A-20 2.0 kW	Straight		Standard Cable: JZSP-UVA331-□□-E Flexible Cable: JZSP-UVA341-□□-E	<ul style="list-style-type: none"> Main Circuit Power Supply Cable Standard Cable: JZSP-UVA301-□□-E Flexible Cable: JZSP-UVA321-□□-E Holding Brake Cable*² JZSP-U7B23-□□-E
	Right-angle* ¹		Standard Cable: JZSP-UVA332-□□-E Flexible Cable: JZSP-UVA342-□□-E	<ul style="list-style-type: none"> Main Circuit Power Supply Cable Standard Cable: JZSP-UVA302-□□-E Flexible Cable: JZSP-UVA322-□□-E Holding Brake Cable*² JZSP-U7B24-□□-E
SGM7A-25 2.5 kW	Straight		Standard Cable: JZSP-U7A551-□□-E Flexible Cable: JZSP-U7A561-□□-E	<ul style="list-style-type: none"> Main Circuit Power Supply Cable Standard Cable: JZSP-UVA501-□□-E Flexible Cable: JZSP-UVA521-□□-E Holding Brake Cable*² JZSP-U7B23-□□-E
	Right-angle* ¹		Standard Cable: JZSP-U7A552-□□-E Flexible Cable: JZSP-U7A562-□□-E	<ul style="list-style-type: none"> Main Circuit Power Supply Cable Standard Cable: JZSP-UVA502-□□-E Flexible Cable: JZSP-UVA522-□□-E Holding Brake Cable*² JZSP-U7B24-□□-E

Continued on next page.

*1. The lead installation direction is away from the load. Consult your Yaskawa representative for other lead installation directions.

*2. Flexible Cables are provided as a standard feature.

Continued from previous page.

Servomotor Model	Connector Type	Appearance	Order Numbers of Main Power Supply Cable and Holding Brake Cable	Individual Cable Order Numbers
SGM7A-30 3.0 kW	Straight		Standard Cable: JZSP-UVA631-□□-E Flexible Cable: JZSP-UVA641-□□-E	<ul style="list-style-type: none"> Main Circuit Power Supply Cable Standard Cable: JZSP-UVA601-□□-E Flexible Cable: JZSP-UVA621-□□-E Holding Brake Cable*² JZSP-U7B23-□□-E
	Right-angle* ¹		Standard Cable: JZSP-UVA632-□□-E Flexible Cable: JZSP-UVA642-□□-E	<ul style="list-style-type: none"> Main Circuit Power Supply Cable Standard Cable: JZSP-UVA602-□□-E Flexible Cable: JZSP-UVA622-□□-E Holding Brake Cable*² JZSP-U7B24-□□-E
SGM7A-40, -50 4.0 kW, 5.0 kW	Straight		Standard Cable: JZSP-UVA731-□□-E Flexible Cable: JZSP-UVA741-□□-E	<ul style="list-style-type: none"> Main Circuit Power Supply Cable Standard Cable: JZSP-UVA701-□□-E Flexible Cable: JZSP-UVA721-□□-E Holding Brake Cable*² JZSP-U7B23-□□-E
	Right-angle* ¹		Standard Cable: JZSP-UVA732-□□-E Flexible Cable: JZSP-UVA742-□□-E	<ul style="list-style-type: none"> Main Circuit Power Supply Cable Standard Cable: JZSP-UVA702-□□-E Flexible Cable: JZSP-UVA722-□□-E Holding Brake Cable*² JZSP-U7B24-□□-E

*1. The lead installation direction is away from the load. Consult your Yaskawa representative for other lead installation directions.

*2. Flexible Cables are provided as a standard feature.

Wiring Specifications

SGM7A-A5 to -10 (50 W to 1.0 kW)				SGM7A-15 to -50 (1.5 kW to 5.0 kW)			
SERVOPACK Leads		Servomotor Connector		SERVOPACK Leads		Servomotor Connector	
Wire Color	Signal	Signal	Pin	Wire Color	Signal	Signal	Pin
Green/yellow	FG	FG	1	Red	Phase U	Phase U	A
Blue	Phase W	Phase W	2	White	Phase V	Phase V	B
White	Phase V	Phase V	3	Black or blue	Phase W	Phase W	C
Red	Phase U	Phase U	4	Green or green/yellow	FG	FG	D
Black	Brake	Brake	5				
Black	Brake	Brake	6	Black	Brake	Brake	1
				White	Brake	Brake	2

Note: There is no polarity for the connection to the holding brake.

4.3 User-Assembled Wiring Materials for Servomotor Main Circuit Cables: SGM7A-A5 to -10

4.3.1 Servomotor Connector Kits

Selection Table

Servomotor Model	Servomotor Capacity	Order Number*
SGM7A-A5 to -C2	50 W to 150 W	JZSP-C7M9-1-E
SGM7A-02 to -06	200 W to 600 W	JZSP-C7M9-2-E
SGM7A-08 or -10	750 W or 1.0 kW	JZSP-C7M9-3-E

* Cables are not included. Purchase them separately.

◆ SGM7A-A5 to -C2 (50 W to 150 W)

Item		Description
Order Number		JZSP-C7M9-1-E
Manufacturer		J.S.T. Mfg. Co., Ltd.
User Instructions		JFA Connector J-1700
Compo- nents	Receptacle	J17S-06FMH-7KL-M-CF
	Contacts	SJ1F-01GF-P0.8
Applicable Wire Sizes		Power terminals: AWG20 Holding brake terminals: AWG20 to AWG24
Applicable Cable Diameter		7 mm ±0.3 mm
Outer Diameter of Insulating Sheath		1.11 mm to 1.53 mm
Mounting Screws		M2 pan-head screws
Crimp- ing Tool*	Hand Tool	YRS-8841
	Applicator	APLMK SJ1F/M01-08
External Dimensions [mm]	■ Cable on Non-load Side 	■ Cable on Load Side

* A Crimping Tool is required. Contact the connector manufacturer for details.

◆ SGM7A-02 to -06 (200 W to 600 W)

Item		Description
Order Number		JZSP-C7M9-2-E
Manufacturer		J.S.T. Mfg. Co., Ltd.
User Instructions		JFA Connector J-2700
Compo- nents	Receptacle	J27S-06FMH-7KL-M-CF
	Contacts	SJ2F-01GF-P1.0
Applicable Wire Sizes		Power terminals: AWG20 Holding brake terminals: AWG20 to AWG24
Applicable Cable Diameter		7 mm ±0.3 mm
Outer Diameter of Insulating Sheath		1.11 mm to 1.53 mm
Mounting Screws		M2 pan-head screws
Crimp- ing Tool*	Hand Tool	YRS-8861
	Applicator	APLMK SJ2F/M01-10
External Dimensions [mm]		<p>■ Cable on Non-load Side</p>
		<p>■ Cable on Load Side</p>

* A Crimping Tool is required. Contact the connector manufacturer for details.

4.3.1 Servomotor Connector Kits

◆ SGM7A-08 or -10 (750 W or 1.0 kW)

Item		Description
Order Number		JZSP-C7M9-3-E
Manufacturer		J.S.T. Mfg. Co., Ltd.
User Instructions		JFA Connector J-3700
Components	Receptacle	J37S-06FMH-8KL-M-CF
	Contacts	Power terminals: SJ3F-41GF-P1.8 Holding brake terminals: SJ3F-01GF-P1.8
Applicable Wire Sizes		Power terminals: AWG16 Holding brake terminals: AWG20 to AWG24
Applicable Cable Diameter		8 mm ±0.3 mm
Outer Diameter of Insulating Sheath		Power terminals: 1.53 mm to 2.5 mm Holding brake terminals: 1.11 mm to 1.86 mm
Mounting Screws		M2.5 pan-head screws
Crimping Tool*	Hand Tool	Power terminals: YRF-880 Holding brake terminals: YRF-881
	Applicator	Power terminals: APLMK SJ3F/M41-20 Holding brake terminals: APLMK SJ3F/M01-20
External Dimensions [mm]	<div style="display: flex; justify-content: space-between;"> <div style="width: 48%;"> <p>■ Cable on Non-load Side</p> </div> <div style="width: 48%;"> <p>■ Cable on Load Side</p> </div> </div>	

* A Crimping Tool is required. Contact the connector manufacturer for details.

4.3.2 Cables without Connectors

Selection Table

Servomotor Model	Order Number*	
	Standard Cable	Flexible Cable
SGM7A-A5 to -C2 50 W to 150 W	JZSP-CSM90-□□-E	JZSP-C7M29-□□-E
SGM7A-02 to -06 200 W to 600 W		
SGM7A-08 or -10 750 W or 1.0 kW	JZSP-CSM91-□□-E	JZSP-CSM81-□□-E

* Replace the boxes (□□) in the order number with the cable length (05, 10, 15, 20, 30, 40, or 50).

◆ SGM7A-A5 to -06 (50 W to 600 W)

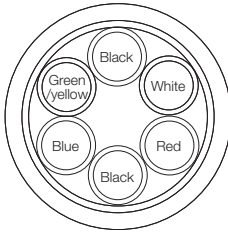
Item	Standard Cable	Flexible Cable
Order Number*	JZSP-CSM90-□□-E (maximum length: 50 m)	JZSP-C7M29-□□-E (maximum length: 50 m)
Specifications	UL2517 (rated temperature:105°C) AWG20 × 6C	UL2517 (rated temperature:105°C) AWG20 × 4C, AWG22C × 2C
	Power lines: AWG20 (0.52 mm ²) Outer diameter of insulating sheath: 1.53 mm	Power lines: AWG20 (0.52 mm ²) Outer diameter of insulating sheath: 1.37 mm
	Holding brake lines: AWG20 (0.52 mm ²) Outer diameter of insulating sheath: 1.53 mm	Holding brake lines: AWG22 (0.33 mm ²) Outer diameter of insulating sheath: 1.37 mm
Finished Diameter	7 mm ±0.3 mm	
Internal Structure and Lead Colors		

* Replace the boxes (□□) in the order number with the cable length (05, 10, 15, 20, 30, 40, or 50).

◆ SGM7A-08 or -10 (750 W or 1.0 kW)

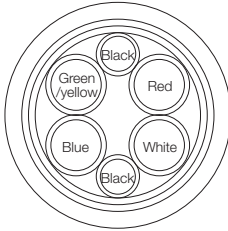
Item	Standard Cable	Flexible Cable
Order Number*	JZSP-CSM91-□□-E (maximum length: 50 m)	JZSP-CSM81-□□-E (maximum length: 50 m)
Specifications	UL2517 (rated temperature:105°C) AWG16 × 4C, AWG20 × 2C	UL2517 (rated temperature:105°C) AWG16 × 4C, AWG22 × 2C
	Power lines: AWG16 (1.31 mm ²) Outer diameter of insulating sheath: 2.15 mm	Power lines: AWG16 (1.31 mm ²) Outer diameter of insulating sheath: 2.35 mm
	Holding brake lines: AWG20 (0.52 mm ²) Outer diameter of insulating sheath: 1.6 mm	Holding brake lines: AWG22 (0.33 mm ²) Outer diameter of insulating sheath: 1.37 mm
Finished Diameter	8 mm ±0.3 mm	
Internal Structure and Lead Colors		

* Replace the boxes (□□) in the order number with the cable length (05, 10, 15, 20, 30, 40, or 50).

4.4 User-Assembled Wiring Materials for Servomotor Main Circuit Cables: SGM7A-15 to -70

If you need standard-structure Servomotor connectors, consult your Yaskawa representative. To fabricate the cables, refer to this section.

To purchase cables with connectors, refer to the following section.

4.2 Servomotor Main Circuit Cables on page 4-6

If you need Servomotor connectors on both ends that are compliant with an IP67 protective structure and European Safety Standards, fabricate the cables by yourself or consult your Yaskawa representative. To fabricate the cables, refer to this section.

When you fabricate the cables, Yaskawa does not specify what wiring materials to use. Therefore, use appropriate wiring materials for your connectors and the electrical specifications.

4.4.1 Connector Structures

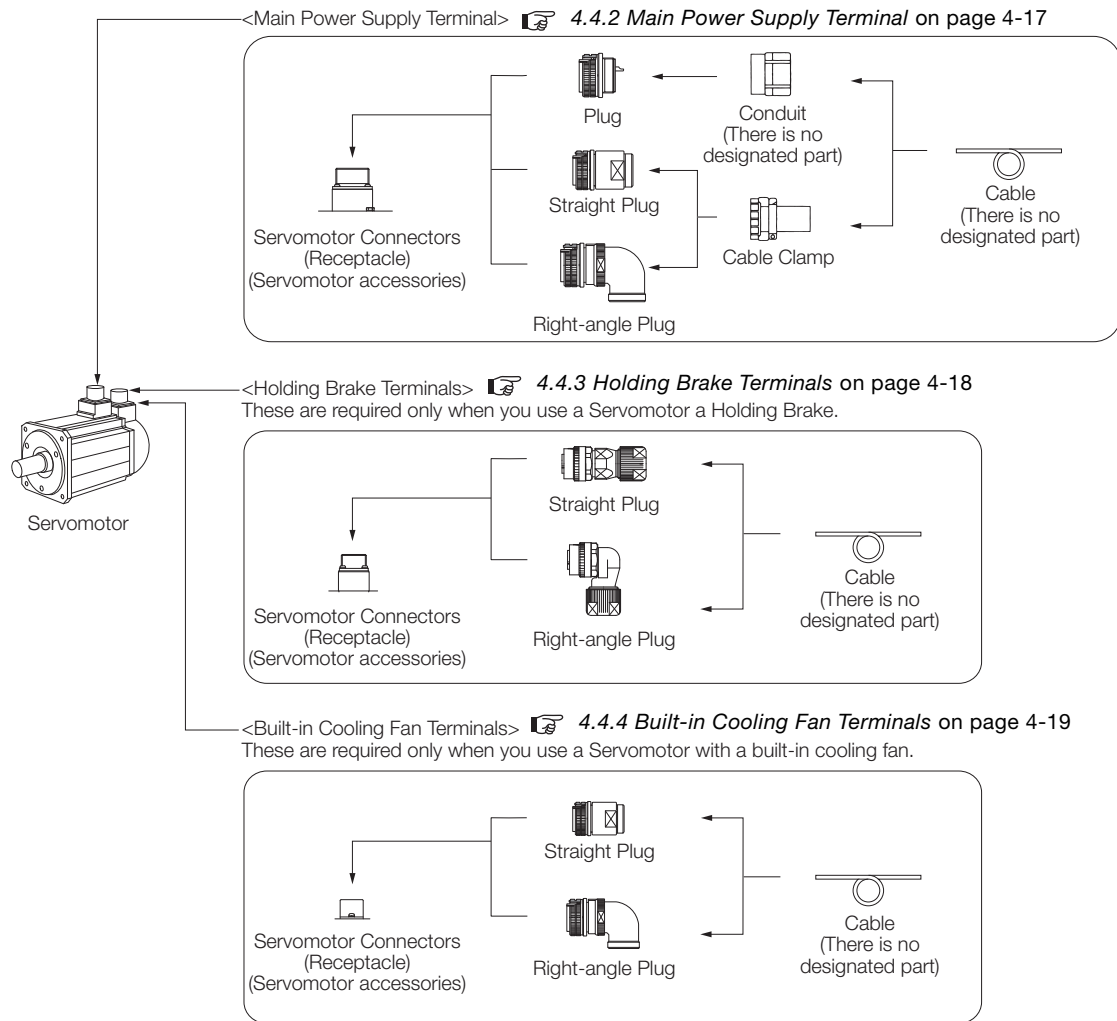

4.4.2 Main Power Supply Terminal

Servomotor Connector (Receptacle)

This connector is an accessory to the Servomotor.

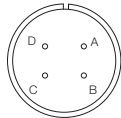
Servomotor Model	Capacity	Servomotor Connector Models	Connector Surface
SGM7A-15 SGM7A-20 SGM7A-25	1.5 kW to 2.5 kW	CE05-2A18-10PD-D (MS Connector model: MS3102A18-10P)	
SGM7A-30 SGM7A-40 SGM7A-50 SGM7A-70	3.0 kW to 7.0 kW	CE05-2A22-22PD-D (MS Connector model: MS3102A22-22P)	

Note: Servomotor Connectors (receptacle) are compatible with MS Connectors. To use a plug not specified by Yaskawa, select an appropriate plug with reference to the MS connector model number in the parentheses.

Cable-Side Connectors (Plug)

Cable-side connectors (plug) are available in the standard environment type and the type compliant with an IP67 protective structure and European Safety Standards and in the straight and right-angle shapes.

◆ Standard Environment Type: Cable-Side Connectors (Plug)

Servomotor Model	Capacity	Order Numbers		Manufacturer	
		Plug	Cable Clamp		
SGM7A-15 SGM7A-20 SGM7A-25	1.5 kW to 2.5 kW	Straight	CE05-6A18-10SD-D-BSS	CE3057-10A-□-D	Fujikura Ltd.
			N/MS3106B18-10S	N/MS3057-10A	Japan Aviation Electronics Industry, Ltd.
		Right-angle	CE05-8A18-10SD-D-BAS	CE3057-10A-□-D	Fujikura Ltd.
			N/MS3108B18-10S	N/MS3057-10A	Japan Aviation Electronics Industry, Ltd.
SGM7A-30 SGM7A-40 SGM7A-50 SGM7A-70	3.0 kW to 7.0 kW	Straight	CE05-6A22-22SD-D-BSS	CE3057-12A-□-D	Fujikura Ltd.
			N/MS3106B22-22S	N/MS3057-12A	Japan Aviation Electronics Industry, Ltd.
		Right-angle	CE05-8A22-22SD-D-BAS	CE3057-12A-□-D	Fujikura Ltd.
			N/MS3108B22-22S	N/MS3057-12A	Japan Aviation Electronics Industry, Ltd.

4.4.3 Holding Brake Terminals

◆ Type Compliant with an IP67 Protective Structure and European Safety Standards: Cable-Side Connectors (Plug)

Servomotor Model	Capacity	Order Numbers				Manufacturer
		Plug		Cable Clamp		
SGM7A-15 SGM7A-20 SGM7A-25	1.5 kW to 2.5 kW	Single	CE05-6A18-10SD-D*	*		Fujikura Ltd.
		Straight	CE05-6A18-10SD-D-BSS	Order Numbers	Applicable Cable Diameter (Reference) [mm]	
				CE3057-10A-1-D	10.5 to 14.1	
Right-angle	CE05-8A18-10SD-D-BAS	CE3057-10A-2-D	8.5 to 11.0			
		CE3057-10A-3-D	6.5 to 8.7			
SGM7A-30 SGM7A-40 SGM7A-50 SGM7A-70	3.0 kW to 7.0 kW	Single	CE05-6A22-22SD-D*	*		
		Straight	CE05-6A22-22SD-D-BSS	Order Numbers	Applicable Cable Diameter (Reference) [mm]	
				CE3057-12A-1-D	12.5 to 16.0	
Right-angle	CE05-8A22-22SD-D-BAS	CE3057-12A-2-D	9.5 to 13.0			
		CE3057-12A-3-D	6.8 to 10.0			
				CE3057-12A-7-D	14.5 to 17.0	

* Using a single plug does not require a Cable Clamp. However, a conduit is required instead of a Cable Clamp. Yaskawa does not specify a specific conduit. For the conduit grounding, contact the manufacturer of the conduit.

4.4.3 Holding Brake Terminals

These are required only when you use a Servomotor with a Holding Brake.

Servomotor Connector (Receptacle)

This connector is an accessory to the Servomotor.

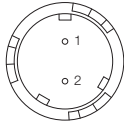
Servomotor Model	Capacity	Servomotor Connector Models	Connector Surface
SGM7A-15 SGM7A-20 SGM7A-25 SGM7A-30 SGM7A-40 SGM7A-50	1.5 kW to 5.0 kW	CM10-R2P-D	

Cable-Side Connectors (Plug)

Cable-side connectors (plug) are compliant with an IP67 protective structure and European Safety Standards. They are available in the straight and right-angle shapes.

Servomotor Model	Capacity	Order Numbers		Applicable Cable Diameter (Reference)	Manufacturer
SGM7A-15 SGM7A-20 SGM7A-25 SGM7A-30 SGM7A-40 SGM7A-50	1.5 kW to 5.0 kW	Straight	CM10-SP2S-S-D	4.0 mm to 6.0 mm	Fujikura Ltd.
			CM10-SP2S-M-D	6.0 mm to 9.0 mm	
			CM10-SP2S-L-D	9.0 mm to 11.6 mm	
		Right-angle	CM10-AP2S-S-D	4.0 mm to 6.0 mm	
			CM10-AP2S-M-D	6.0 mm to 9.0 mm	
			CM10-AP2S-L-D	9.0 mm to 11.6 mm	

Information When consulting with your Yaskawa representative, refer to the following order number format.

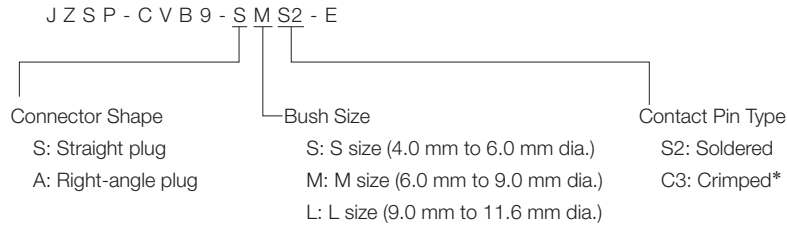

* Crimping Tool: A 357J-50448T from Fujikura Ltd. is required.

Information Other connector specifications

Item	Specifications
User Instructions	<ul style="list-style-type: none"> • Straight Plug (CM10-SP2S-□-D): TC-583 • Right-Angle Plug (CM10-AP2S-□-D): TC-573
Contact Models	<ul style="list-style-type: none"> ■ Loose Contacts (100 per bag) <ul style="list-style-type: none"> • Crimped Contacts: CM10-#22SC(C3)-100 Wire size: AWG16 to AWG20 Outer diameter of insulating sheath: 1.87 mm to 2.45 mm Manual Crimping Tool: 357J-50448T • Soldered Contacts: CM10-#22SC(S2)-100 Wire size: AWG16 max. ■ Reeled Contacts (4,000 per reel) <ul style="list-style-type: none"> • Crimped Contacts: CM10-#22SC(C3)-4000 Wire size: AWG16 to AWG20 Outer diameter of insulating sheath: 1.87 mm to 2.45 mm Semi-automatic Crimping Tool: AP-A50541T (Set) AP-A50541T-1 (Applicator) <p>Note: The Semi-automatic Tool Set includes the press and Applicator (crimper).</p>

4.4.4 Built-in Cooling Fan Terminals

These are required only when you use a Servomotor with a built-in cooling fan. A cooling fan is built into the SGM7A-70 Servomotor only.

Servomotor Connector (Receptacle)

This connector is an accessory to the Servomotor.

Servomotor Model	Capacity	Servomotor Connector Models	Connector Surface
SGM7A-70	7.0 kW	MS3102A14S-6P	

Cable-Side Connectors (Plug)

Cable-side connectors (plug) are compliant with an IP67 protective structure and European Safety Standards.

Servomotor Model	Capacity	Order Numbers		Manufacturer
		Plug	Cable Clamp	
SGM7A-70	7.0 kW	MS3108B14S-6S	MS3057-6A	Japan Aviation Electronics Industry, Ltd.

Information Prepare wiring materials that are appropriate for the following cooling fan specifications.

- Single-phase 200 V
- 50/60 Hz
- 17/15 W
- 0.11/0.09 A

4.4.5 Connector External Dimensions

Main Power Supply Terminal

◆ Straight Plug: CE05-6A□□-□□SD-D-BSS (from Fujikura Ltd.)

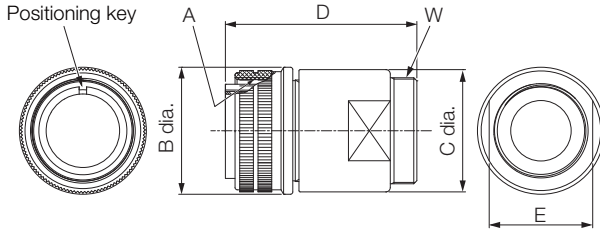

Unit: mm

Model	Shell Size	Joint Thread A	Joint Nut Outer Diameter B $+0$ -0.38 Dia.	Max. Diameter C ± 0.8 Dia.	Total Length D Max.	Spanner Fitting Width Across Flat E	Cable Clamp Mounting Thread W
CE05-6A18-10SD-D-BSS	18	1-1/8-18UNEF-2B	34.13	32.1	57	26.7	1-20UNEF-2A
CE05-6A22-22SD-D-BSS	22	1-3/8-18UNEF-2B	40.48	38.3	61	32.4	1-3/16-18UNEF-2A

◆ Straight Plug: N/MS3106B□□-□□S (from Japan Aviation Electronics Industry, Ltd.)

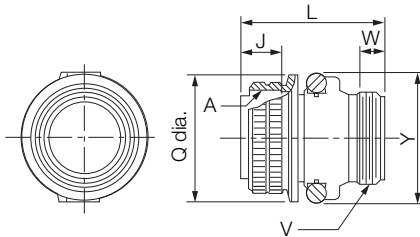

Unit: mm

Model	Shell Size	Joint Thread A	Length of Joint J ± 0.12	Total Length L Max.	Joint Nut Outer Diameter Q $+0$ -0.38 Dia.	Cable Clamp Mounting Thread V	Effective Thread Length W Min.	Maximum Width Y Max.
N/MS3106B18-10S	18	1-1/8-18UNEF	18.26	52.37	34.13	1-20UNEF	9.53	42
N/MS3106B22-22S	22	1-3/8-18UNEF	18.26	55.57	40.48	1-3/16-18UNEF	9.53	50

◆ Right-Angle Plug: CE05-8A□□-□□SD-D-BAS (from Fujikura Ltd.)

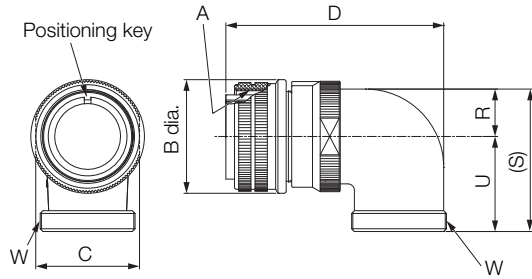

Unit: mm

Model	Shell Size	Joint Thread A	Joint Nut Outer Diameter B ⁺⁰ _{-0.38} Dia.	Spanner Fitting Width Across Flat C	Total Length D Max.	Cable Clamp Mounting Thread W	R ± 0.7	U ± 0.7	(S) ± 1
CE05-8A18-10SD-D-BAS	18	1-1/8-18UNEF-2B	34.13	30.0	69.5	1-20UNEF-2A	13.2	30.2	43.4
CE05-8A22-22SD-D-BAS	22	1-3/8-18UNEF-2B	40.48	36.2	75.5	1-3/16-18UNEF-2A	16.3	33.3	49.6

◆ Right-Angle Plug: N/MS3108B□□-□□S (from Japan Aviation Electronics Industry, Ltd.)

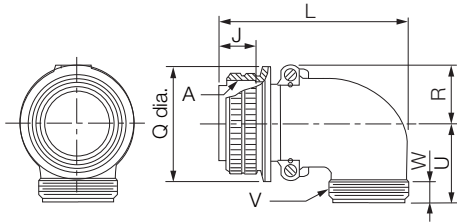

Unit: mm

Model	Shell Size	Joint Thread A	Length of Joint J ± 0.12	Total Length L Max.	Joint Nut Outer Diameter Q ⁺⁰ _{-0.38} Dia.	R ± 0.5	U ± 0.5	Cable Clamp Mounting Thread V	Effective Thread Length W Min.
N/MS3108B18-10S	18	1-1/8-18UNEF	18.26	68.27	34.13	20.5	30.2	1-20UNEF	9.53
N/MS3108B22-22S	22	1-3/8-18UNEF	18.26	76.98	40.48	24.1	33.3	1-3/16-18UNEF	9.53

4.4.5 Connector External Dimensions

◆ Cable Clamp: CE3057-□□A-□-D (from Fujikura Ltd.)

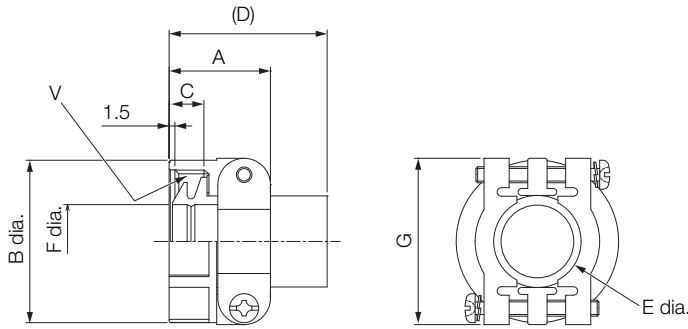

Unit: mm

Model	Applicable Connector Shell Size	Total Length A ± 0.7	Outer Diameter B Dia.	Effective Thread Length C	(D)	Bushing Outer Diameter E Dia.	Bushing Inner Diameter F Dia.	G ± 0.7	Mounting Thread V	Attached Bushing	Applicable Cable Diameter (Reference)
CE3057-10A-1-D	18	23.83	30.1	10.31	(41.3)	15.8	14.1	31.7	1-20UNEF-2B	CE3420-10-1	10.5 to 14.1
CE3057-10A-2-D							11			CE3420-10-2	8.5 to 11.0
CE3057-10A-3-D							8.7			CE3420-10-3	6.5 to 8.7
CE3057-12A-1-D	22	23.83	35	10.31	(41.3)	19.0	16	37.3	1-3/16-18UNEF-2B	CE3420-12-1	12.5 to 16.0
CE3057-12A-2-D							13			CE3420-12-2	9.5 to 13.0
CE3057-12A-3-D							10			CE3420-12-3	6.8 to 10.0
CE3057-12A-7-D							17			CE3420-12-7	14.5 to 17.0

◆ Cable Clamp: N/MS3057-□□A (from Japan Aviation Electronics Industry, Ltd.)

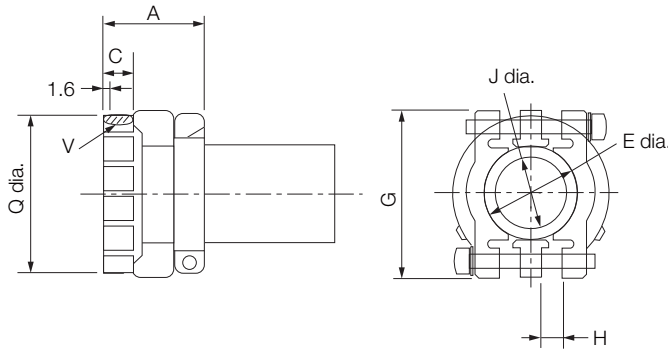

Unit: mm

Model	Applicable Connector Shell Size	Total Length A ± 0.7	Effective Thread Length C	Cable Clamp Inner Diameter E Dia.	G ± 0.7	Slide Range H	Bushing Inner Diameter J Dia.	Mounting Thread V	Outer Diameter Q ± 0.7 Dia.	Attached Bushing
N/MS3057-10A	18	23.8	10.3	15.9	31.7	3.2	14.3	1-20UNEF	30.1	AN3420-10
N/MS3057-12A	22	23.8	10.3	19	37.3	4	15.9	1-3/16-18UNEF	35.0	AN3420-12

Note: A rubber bushing is included.

Holding Brake Terminals

◆ Straight Plug: CM10-SP2S-□-D

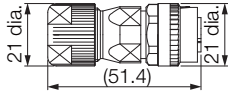

Unit: mm

◆ Right-Angle Plug: CM10-AP2S-□-D

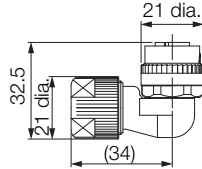

Unit: mm

4.5 Encoder Cables of 20 m or Less

4.5.1 Encoder Cables for Incremental Encoders or Batteryless Absolute Encoders

SGM7A-A5 to -10 (50 W to 1.0 kW)

◆ Selection Table

Cable Direction	Servomotor Model	Length (L)	Order Number* ¹	
			Standard Cable	Flexible Cable* ^{2, *3}
Load side	SGM7A-A5 to -10 50 W to 1.0 kW	3 m, 5 m, 10 m, 15 m, and 20 m	JZSP-C7PI0D-□□-E	JZSP-C7PI2D-□□-E
Non-load side			JZSP-C7PI0E-□□-E	JZSP-C7PI2E-□□-E

*1. Replace the boxes (□□) in the order number with the cable length (03, 05, 10, 15, or 20).

*2. Use Flexible Cables for moving parts of machines, such as robots.

*3. The recommended bending radius (R) is 46 mm or larger.

◆ External Dimensions

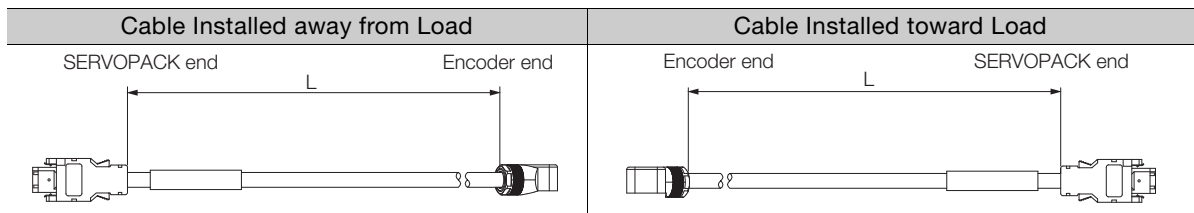

◆ Wiring Specifications

Standard Cable				Flexible Cable			
SERVOPACK end		Encoder (motor) end		SERVOPACK end		Encoder (motor) end	
Pin	Signal	Pin	Wire Color	Pin	Signal	Pin	Wire Color
6	/PS	5	Light blue/white	6	/PS	5	Black/pink
5	PS	4	Light blue	5	PS	4	Red/pink
4	BAT (-)	8	Orange/white	4	BAT (-)	8	Black/light blue
3	BAT (+)	9	Orange	3	BAT (+)	9	Red/light blue
2	PG 0 V	3	Black	2	PG 0 V	3	Light green
1	PG 5 V	6	Red	1	PG 5 V	6	Orange
Shell	FG	Shell	FG	Shell	FG	Shell	FG

SGM7A-15 to -70 (1.5 kW to 7.0 kW)

◆ Selection Table

Servomotor Model	Connector Specifications	Length (L)	Order Number*1	
			Standard Cable	Flexible Cable*2, *3
SGM7A-15 to -70 1.5 kW to 7.0 kW	Straight	3 m, 5 m, 10 m, 15 m, and 20 m	JZSP-CVP01-□□-E	JZSP-CVP11-□□-E
	Right-angle*4, *5		JZSP-CVP02-□□-E	JZSP-CVP12-□□-E

*1. Replace the boxes (□□) in the order number with the cable length (03, 05, 10, 15, or 20).

*2. Use Flexible Cables for moving parts of machines, such as robots.

*3. The recommended bending radius (R) is 46 mm or larger.

*4. The lead installation direction is away from the load. Consult your Yaskawa representative for other lead installation directions.

*5. An Encoder Cable with a Right-angle Connector cannot be used with the SGM7A-70 (7.0 kW). Use an Encoder Cable with a Straight Connector.

◆ Appearance

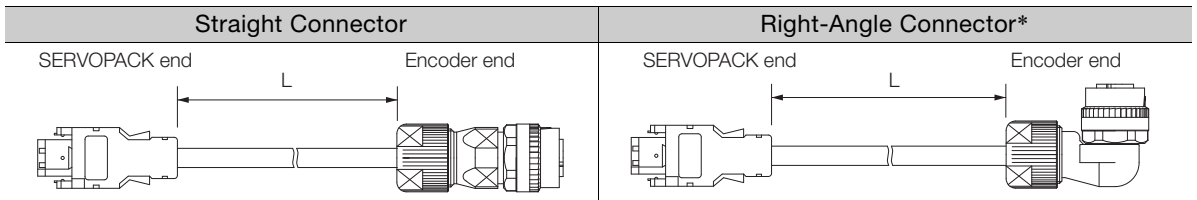

* The lead installation direction is away from the load. Consult your Yaskawa representative for other lead installation directions.

◆ Wiring Specifications

Standard Cable					Flexible Cable				
SERVOPACK end			Encoder (motor) end		SERVOPACK end			Encoder (motor) end	
Pin	Signal		Pin	Wire Color	Pin	Signal	Pin	Wire Color	
6	/PS		2	Light blue/white	6	/PS	2	Black/pink	
5	PS		1	Light blue	5	PS	1	Red/pink	
4	BAT(-)		5	Orange/white	4	BAT(-)	5	Black/light blue	
3	BAT(+)		6	Orange	3	BAT(+)	6	Red/light blue	
2	PG 0V		9	Black	2	PG 0V	9	Light green	
1	PG 5V		4	Red	1	PG 5V	4	Orange	
Shell	FG		10	FG	Shell	FG	10	FG	

4.5.2 Encoder Cables for Absolute Encoders

These cables are equipped with a Battery Case. (A Battery is included.)

Note: If a battery is connected to the host controller, the Battery Case is not required. Use an Encoder Cable for Incremental Encoders or Batteryless Absolute Encoders.

NOTICE

- Install a battery at either the host controller or on the Encoder Cable.
If you install batteries both at the host controller and on the Encoder Cable at the same time, you will create a loop circuit between the batteries, resulting in a risk of damage or burning.

SGM7A-A5 to -10 (50 W to 1.0 kW)

◆ Selection Table

Cable Direction	Servomotor Model	Length (L)	Order Number*1	
			Standard Cable	Flexible Cable*2, *3
Load side	SGM7A-A5 to -10 50 W to 1.0 kW	3 m, 5 m, 10 m, 15 m, and 20 m	JZSP-C7PA0D-□□-E	JZSP-C7PA2D-□□-E
Non-load side			JZSP-C7PA0E-□□-E	JZSP-C7PA2E-□□-E

*1. Replace the boxes (□□) in the order number with the cable length (03, 05, 10, 15, or 20).

*2. Use Flexible Cables for moving parts of machines, such as robots.

*3. The recommended bending radius (R) is 46 mm or larger.

◆ External Dimensions

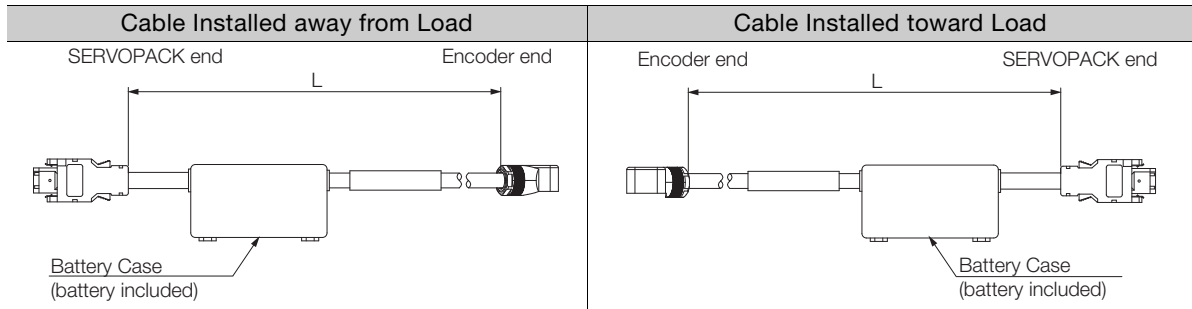

◆ Wiring Specifications

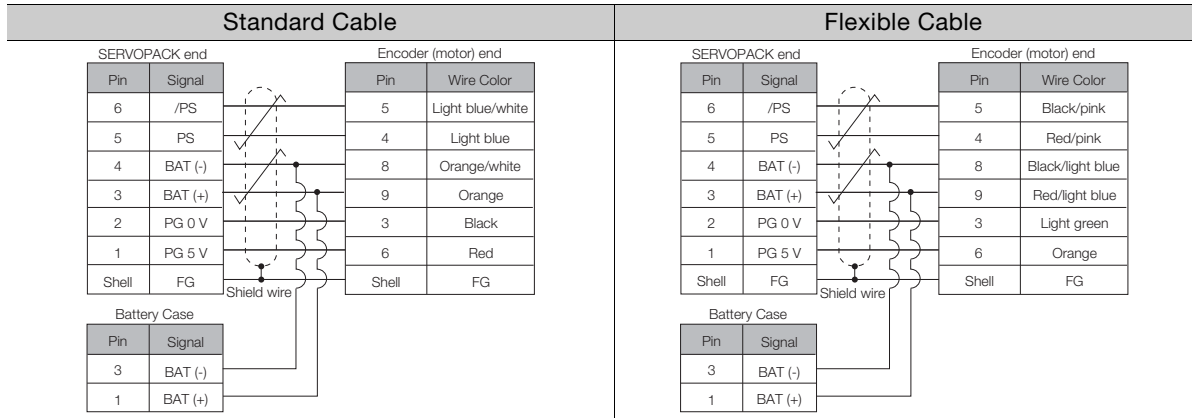

SGM7A-15 to -70 (1.5 kW to 7.0 kW)

◆ Selection Table

Servomotor Model	Connector Specifications	Length (L)	Order Number*1	
			Standard Cable	Flexible Cable*2, *3
SGM7A-15 to -70 1.5 kW to 7.0 kW	Straight	3 m, 5 m, 10 m, 15 m, and 20 m	JZSP-CVP06-□□-E	JZSP-CVP26-□□-E
	Right-angle*4, *5		JZSP-CVP07-□□-E	JZSP-CVP27-□□-E

*1. Replace the boxes (□□) in the order number with the cable length (03, 05, 10, 15, or 20).

*2. Use Flexible Cables for moving parts of machines, such as robots.

*3. The recommended bending radius (R) is 46 mm or larger.

*4. The lead installation direction is away from the load. Consult your Yaskawa representative for other lead installation directions.

*5. An Encoder Cable with a Right-angle Connector cannot be used with the SGM7A-70 (7.0 kW). Use an Encoder Cable with a Straight Connector.

◆ Appearance

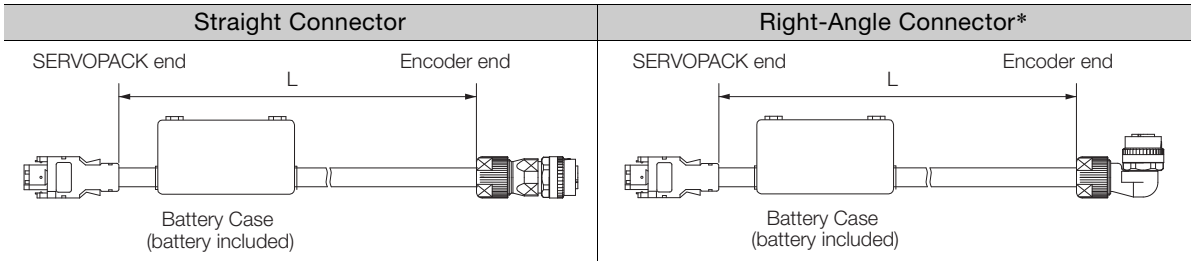

* The lead installation direction is away from the load. Consult your Yaskawa representative for other lead installation directions.

◆ Wiring Specifications



4.6 Relay Encoder Cable of 30 m to 50 m

If the Encoder Cable length exceeds 20 m, be sure to also use a Motor-End Relay Encoder Cable and a SERVOPACK-End Relay Encoder Cable.

If you use a motor with an absolute encoder and a battery is not mounted to the host controller, also obtain a Relay Encoder Cable with a Battery Case in addition to the above two Cables.

NOTICE

- Install a battery at either the host controller or on the Encoder Cable.
If you install batteries both at the host controller and on the Encoder Cable at the same time, you will create a loop circuit between the batteries, resulting in a risk of damage or burning.

4.6.1 Motor-End Relay Encoder Cables

SGM7A-A5 to -10 (50 W to 1.0 kW)

◆ Selection Table

Cable Direction	Specification	Length (L)	Order Number
Load side	Used for all types of encoders.	0.3 m	JZSP-C7PRCD-E
Non-load side			JZSP-C7PRCE-E

◆ Appearance

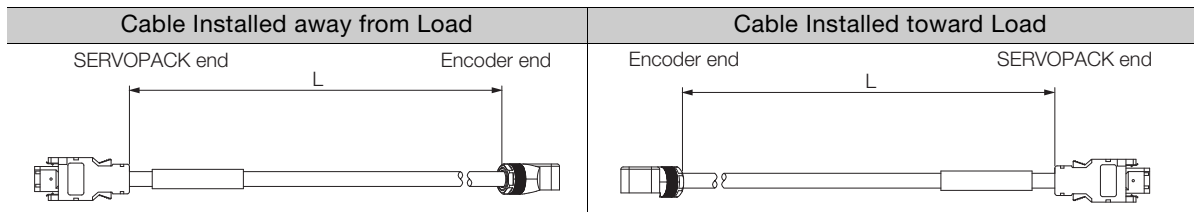

◆ Wiring Specifications

SERVOPACK end		Encoder (motor) end	
Pin	Signal	Pin	Wire Color
6	/PS	5	Light blue/white
5	PS	4	Light blue
4	BAT (-)	8	Orange/white
3	BAT (+)	9	Orange
2	PG 0 V	3	Black
1	PG 5 V	6	Red
Shell	FG	Shell	FG

Shield wire

SGM7A-15 to -70 (1.5 kW to 7.0 kW)

◆ Selection Table

Connector Specifications	Specification	Length (L)	Order Number
Straight Connector	Used for all types of encoders.	0.3 m	JZSP-CVP01-E
Right-Angle Connector*1, *2			JZSP-CVP02-E

- *1. The lead installation direction is away from the load. Consult your Yaskawa representative for other lead installation directions.
 *2. An Encoder Cable with a Right-angle Connector cannot be used with the SGM7A-70 (7.0 kW). Use an Encoder Cable with a Straight Connector.

◆ Appearance

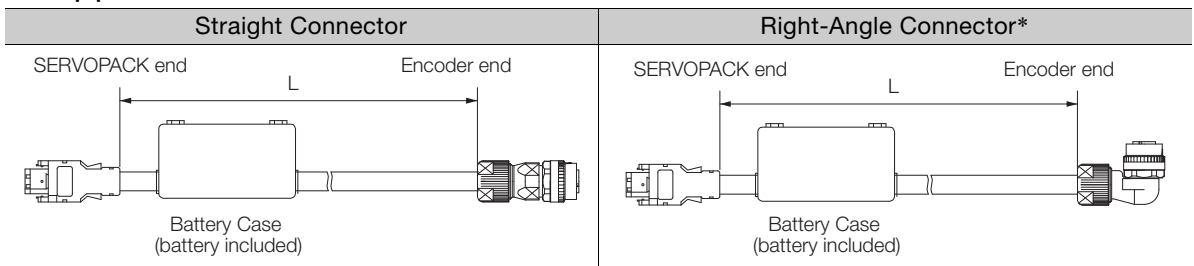

- * The lead installation direction is away from the load. Consult your Yaskawa representative for other lead installation directions.

◆ Wiring Specifications

SERVOPACK end		Encoder (motor) end	
Pin	Signal	Pin	Wire Color
6	/PS	2	Light blue/white
5	PS	1	Light blue
4	BAT(-)	5	Orange/white
3	BAT(+)	6	Orange
2	PG 0 V	9	Black
1	PG 5 V	4	Red
Shell	FG	10	FG

Shield wire

Note: BAT(+) and BAT(-) are wired for an absolute encoder.

4.6.2 SERVOPACK-End Relay Encoder Cables

All Models

◆ Selection Table

Specification	Length (L)	Order Number*
Used for all types of encoders.	30 m, 40 m, and 50 m	JZSP-UCMP00-□□-E

- * Replace the boxes (□□) in the order number with the cable length (30, 40, or 50).

◆ Appearance

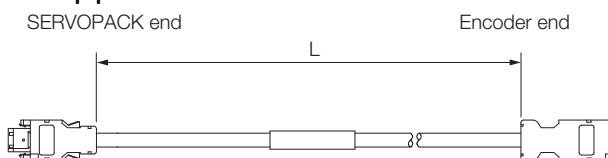

4.6.3 Relay Encoder Cables with Battery Cases

◆ Wiring Specifications

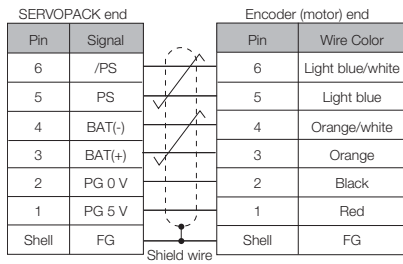

4.6.3 Relay Encoder Cables with Battery Cases

Note: This Cable is not required if you use a Servomotor with an Incremental Encoder, use a Servomotor with a Batteryless Absolute Encoder, or connect a battery to the host controller.

All Models

◆ Selection Table

Length (L)	Order Number
0.3 m	JZSP-CSP12-E

◆ Appearance

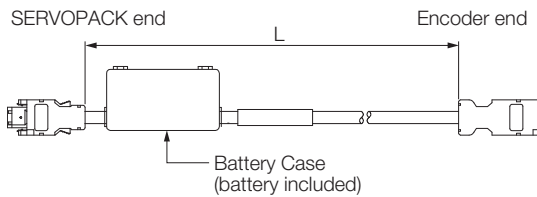

◆ Wiring Specifications

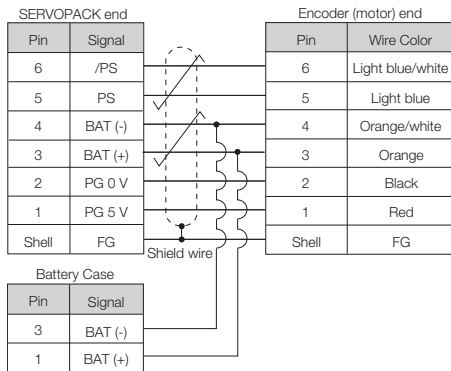

4.7 User-Assembled Wiring Materials for Encoder Cables

4.7.1 Precautions When Using Encoder Cables with a Wiring Length of 30 m to 50 m

When using Encoder Cables with a wiring length of 30 m to 50 m, it is necessary to fabricate two different types of cables.

Cables to be Fabricated	Connectors and Wire Materials Required for Fabrication	Reference Page	Remarks
Motor-End Relay Encoder Cable	SERVOPACK Connector	4.7.2 <i>SERVOPACK Connector Kits</i> on page 4-31	This cable should be 0.3 m or less.
	Servomotor Connector	4.7.3 <i>Encoder Connector Kits</i> on page 4-32	
	Encoder Cables of 20 m or Less	4.7.4 <i>Cables without Connectors</i> on page 4-34	
SERVOPACK-End Relay Encoder Cable	SERVOPACK Connector	4.7.2 <i>SERVOPACK Connector Kits</i> on page 4-31	This cable should be 50 m or less.
	Cable Relay Connector	4.7.3 <i>Encoder Connector Kits</i> on page 4-32	
	Relay Encoder Cable (30 m to 50 m)	4.7.4 <i>Cables without Connectors</i> on page 4-34	

Refer to the following section for details on the connection of the Relay Encoder Cable.

4.1 *Cable Configurations* on page 4-3

4.7.2 SERVOPACK Connector Kits

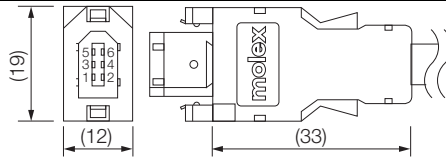
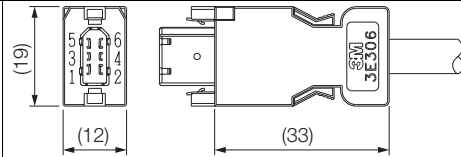
Type	Standard Connector Kit	Compatible Connector Kit
Inquires	Yaskawa representative	3M Japan Limited
Manufacturer	Molex Incorporated	
Order Number	JZSP-CMP9-1-E	
Specifications	55100-0670 (soldered) Product specifications: PS-54280	Receptacle: 3E206-0100 KV (soldered) Shell Kit: 3E306-3200-008 Product specifications: JNPS-1042 and JNPS-1043
External Dimensions [mm]		

Note: Cables are not included. Purchase them separately.

4.7.3 Encoder Connector Kits

SGM7A-A5 to -10 (50 W to 1.0 kW)

◆ Servomotor Connectors

Order Number	JZSP-C7P9-1-E	
Manufacturer	Molex Incorporated	
Components	504678-0070 Loose Connectors: 56161-8181 (crimped), Reeled Connectors: 56161-8081 (crimped)	
Applicable Wire Sizes	AWG22 to AWG26	
Applicable Cable Diameter	6.3 mm to 7.7 mm	
Outer Diameter of Insulating Sheath	1.05 mm to 1.4 mm	
Mounting Screws	M2 pan-head screws (two)	
Application Specifications	AS-504682	
Crimping Specifications	CS-56161	
Crimping Tool*	Hand Tool	57175-5000
Shell Caulking Tool	57331-5100	

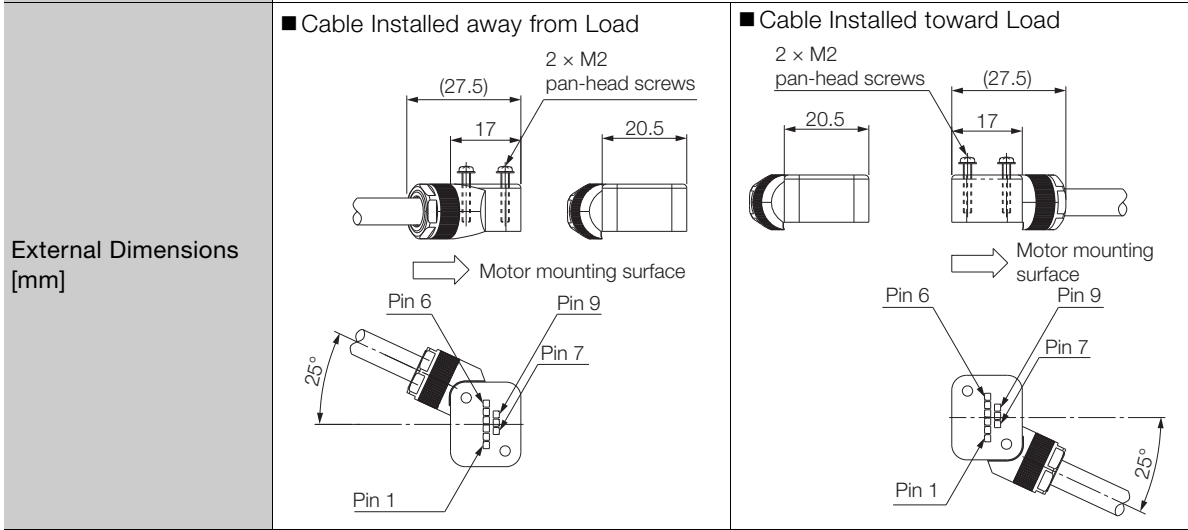

* A Crimping Tool is required. When using other wire sizes, contact the connector manufacturer for crimping tools.

SGM7A-15 to -70 (1.5 kW to 7.0 kW)

◆ IP67-Structure Servomotor Connectors

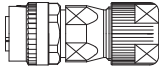
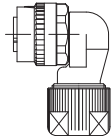
Type	Order Number	Specification	External Dimensions	Manufacturer
Straight Plug	JZSP-CVP9-1-E	<ul style="list-style-type: none"> Plug: CM10-SP10S-M-D Contacts: Crimped*1 CM10-#22SC(C4)-100 Applicable cable diameter: 6.0 mm to 9.0 mm 	 Accessories: Contacts	Fujikura Ltd.
	JZSP-CVP9-3-E	<ul style="list-style-type: none"> Plug: CM10-SP10S-M-D Contacts: Soldered CM10-#22SC(S1)-100 Applicable cable diameter: 6.0 mm to 9.0 mm 		
Right-Angle Plug*2	JZSP-CVP9-2-E	<ul style="list-style-type: none"> Plug: CM10-AP10S-M-D Contacts: Crimped*1 CM10-#22SC(C4)-100 Applicable cable diameter: 6.0 mm to 9.0 mm 	 Accessories: Contacts	
	JZSP-CVP9-4-E	<ul style="list-style-type: none"> Plug: CM10-AP10S-M-D Contacts: Soldered CM10-#22SC(S1)-100 Applicable cable diameter: 6.0 mm to 9.0 mm 		

*1. A Crimping Tool is required. The following Crimping Tool is applicable to the Cables provided by Yaskawa. When using other wire sizes, contact the connector manufacturer for crimping tools.
 Crimping Tool: 357J-52667T

*2. A Right-Angle Connector cannot be used for the encoder connector of the SGM7A-70 (7.0 kW). Use a Straight Connector.

All Models

◆ Cable Relay Connectors

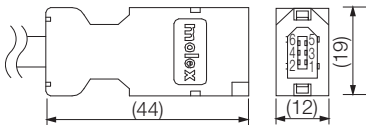
Order Number	JZSP-CMP9-2-E
Manufacturer	Molex Incorporated
Components	54280-0609 (soldered)
Product Specifications	PS-54280
External Dimensions [mm]	

4.7.4 Cables without Connectors

Encoder Cables of 20 m or Less

Item	Standard Cable	Flexible Cable
Order Number*	JZSP-CMP09-□□-E (maximum length: 20 m)	JZSP-CSP39-□□-E (maximum length: 20 m)
Specifications	UL20276 (rated temperature: 80°C) AWG22 × 2C + AWG24 × 2P	UL20276 (rated temperature: 80°C) AWG22 × 2C + AWG24 × 2P
	AWG22 (0.33 mm ²) Outer diameter of insulating sheath: 1.15 mm	AWG22 (0.33 mm ²) Outer diameter of insulating sheath: 1.35 mm
	AWG24 (0.20 mm ²) Outer diameter of insulating sheath: 1.09 mm	AWG24 (0.20 mm ²) Outer diameter of insulating sheath: 1.21 mm
Finished Diameter	6.5 mm	6.8 mm
Internal Structure and Lead Colors		

* Replace the boxes (□□) in the order number with the cable length (05, 10, 15, or 20).

Relay Encoder Cable of 30 m to 50 m

Item	Standard Cable
Order Number*	JZSP-CMP19-□□-E (maximum length: 50 m)
Specifications	UL20276 (rated temperature: 80°C) AWG16 × 2C + AWG26 × 2P
	AWG16 (1.31 mm ²) Outer diameter of insulating sheath: 2.0 mm
	AWG26 (0.13 mm ²) Outer diameter of insulating sheath: 0.91 mm
Finished Diameter	6.8 mm
Internal Structure and Lead Colors	

* Replace the boxes (□□) in the order number with the cable length (30, 40, or 50).

4.8 Wiring Precautions

The wiring precautions are the same as for SGM7M Rotary Servomotors. Refer to the following section.

 2.5 *Wiring Precautions* on page 2-9

Cables and User-Assembled Wiring Materials for SGM7P Rotary Servomotors

5

5.1	Cable Configurations	5-2
5.2	Servomotor Main Circuit Cables	5-4
5.2.1	Servomotor Main Circuit Cables for Servomotors without Holding Brakes	5-4
5.2.2	Servomotor Main Circuit Cables for Servomotors with Holding Brakes	5-5
5.3	User-Assembled Wiring Materials for Servomotor Main Circuit Cables . .	5-6
5.3.1	Servomotor Connector Kits	5-6
5.3.2	Cables without Connectors	5-8
5.4	Encoder Cables of 20 m or Less	5-9
5.4.1	Encoder Cables for Incremental Encoders or Batteryless Absolute Encoders	5-9
5.4.2	Encoder Cables for Absolute Encoders	5-11
5.5	Relay Encoder Cable of 30 m to 50 m	5-13
5.5.1	Motor-End Relay Encoder Cables	5-13
5.5.2	SERVOPACK-End Relay Encoder Cables	5-13
5.5.3	Relay Encoder Cables with Battery Cases	5-14
5.6	User-Assembled Wiring Materials for Encoder Cables . .	5-15
5.6.1	Precautions When Using Encoder Cables with a Wiring Length of 30 m to 50 m	5-15
5.6.2	SERVOPACK Connector Kits	5-15
5.6.3	Encoder Connector Kits	5-16
5.6.4	Cables without Connectors	5-17
5.7	Wiring Precautions	5-18

5.1 Cable Configurations

- SGM7P-01 to -04 (for 100 W to 400 W)

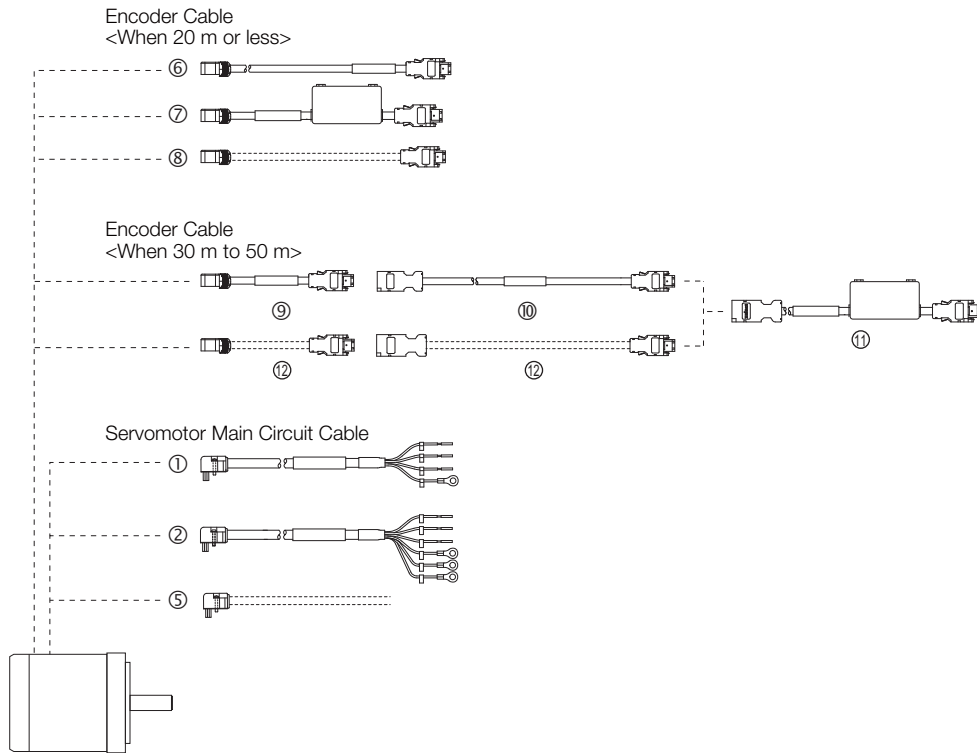

- SGM7P-08, -15 (for 750 W, 1.5 kW)

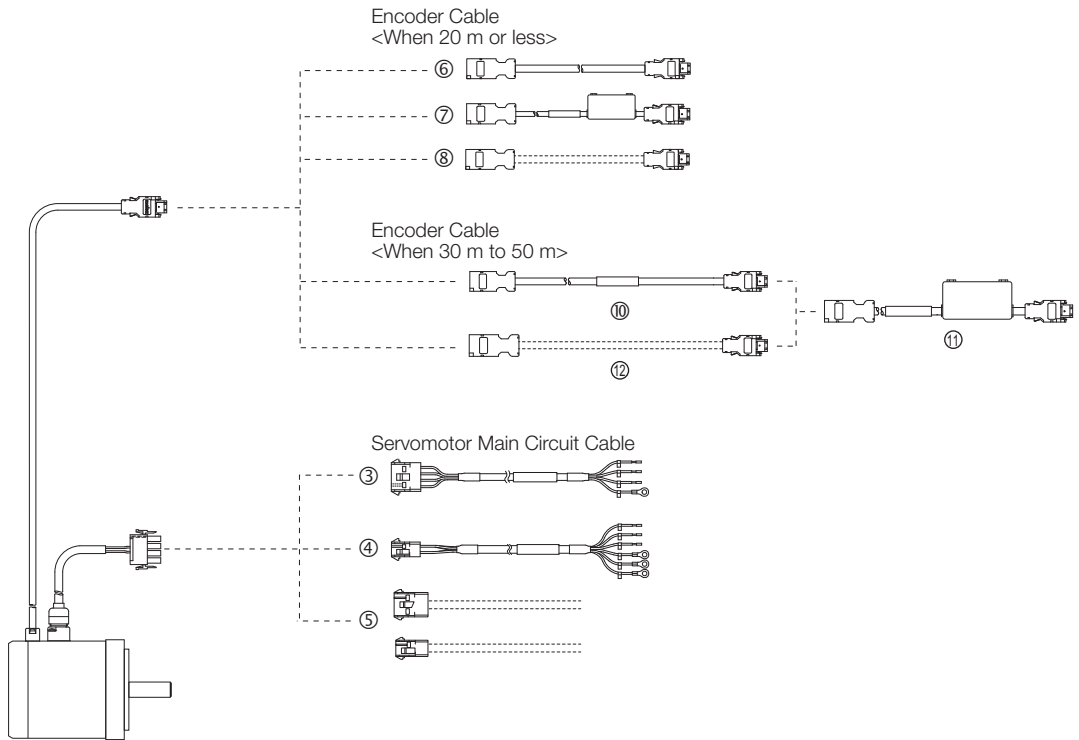

Note: If the Encoder Cable length exceeds 20 m, be sure to also connect Relay Encoder Cables as shown at ⑩ to ⑫ in the above diagram.

No.	Cable Type	Reference	
①	Servomotor Main Circuit Cables	For Servomotors without Holding Brakes, 100 W to 400 W ^{*1}	page 5-4
②		For Servomotors with Holding Brakes, 100 W to 400 W ^{*1}	page 5-5
③		For Servomotors without Holding Brakes, 750 W or 1.5 kW	page 5-4
④		For Servomotors with Holding Brakes, 750 W or 1.5 kW	page 5-5
⑤	User-Assembled Wiring Materials for Servomotor Main Circuit Cables	Connectors	page 5-6
		Cables without Connectors	page 5-8
⑥	Encoder Cables of 20 m or Less for Incremental Encoders or Batteryless Absolute Encoders	page 5-9	
⑦	Encoder Cables of 20 m or Less with Battery Cases for Absolute Encoders ^{*2}	page 5-11	
⑧	User-Assembled Wiring Materials for Encoder Cables ^{*3}	Connectors	page 5-15
		Cables without Connectors	page 5-17
⑨	Motor-End Relay Encoder Cables	page 5-12	
⑩	SERVOPACK-End Relay Encoder Cables		
⑪	Relay Encoder Cables with Battery Cases ^{*4}		
⑫	User-Assembled Wiring Materials for Relay Encoder Cables of 30 m to 50 m ^{*3}	Connectors	page 5-15
		Cables without Connectors	page 5-17

*1. The lead installation direction is toward the load. Any other lead installation direction is not allowed.

*2. If a battery is connected to the host controller, the Battery Case is not required. Use an Encoder Cable for Incremental Encoders or Batteryless Absolute Encoders.

*3. When you fabricate the Encoder Cable, always connect the shield wire from the Encoder Cable to the connector (shell). There is a risk of failure or malfunction.

*4. This Cable is not required if you use a Servomotor with an Incremental Encoder, use a Servomotor with a Batteryless Absolute Encoder, or connect a battery to the host controller.

5.2 Servomotor Main Circuit Cables

5.2.1 Servomotor Main Circuit Cables for Servomotors without Holding Brakes

Selection Table

Servomotor Model	Length (L)	Order Number*1	
		Standard Cable	Flexible Cable*2, *3
SGM7P-01 100 W	3 m, 5 m, 10 m, 15 m, 20 m, 30 m, 40 m, and 50 m	JZSP-CSM01-□□-E*4	JZSP-CSM21-□□-E*4
SGM7P-02 or -04 200 W or 400 W		JZSP-CSM02-□□-E*4	JZSP-CSM22-□□-E*4
SGM7P-08 750 W		JZSP-CMM00-□□-E	JZSP-CMM01-□□-E
SGM7P-15 1.5 kW		JZSP-CMM20-□□-E	Note: Flexible Cables are not available.

*1. Replace the boxes (□□) in the order number with the cable length (03, 05, 10, 15, 20, 30, 40, or 50).

*2. Use Flexible Cables for moving parts of machines, such as robots.

*3. The recommended bending radius (R) is 90 mm or larger.

*4. The lead installation direction is toward the load. Any other lead installation direction is not allowed.

Note: If the length of the Servomotor Main Circuit Cable exceeds 20 m, the intermittent duty zone in the torque-motor speed characteristics will become smaller because the voltage drop increases.

Appearance

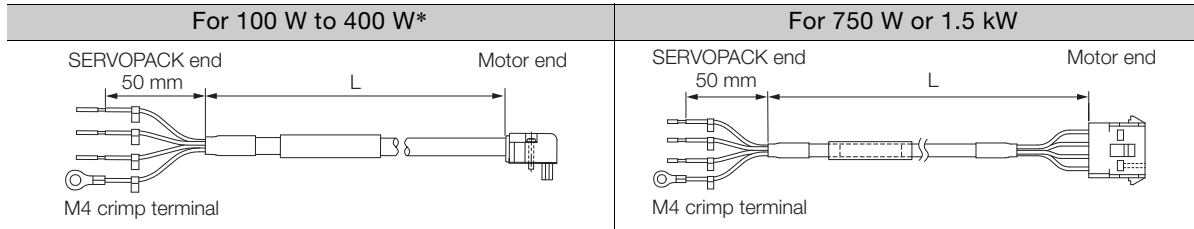

* The lead installation direction is toward the load. Any other lead installation direction is not allowed.

Wiring Specifications

For 100 W to 400 W				For 750 W or 1.5 kW			
SERVOPACK Leads		Servomotor Connector		SERVOPACK Leads		Servomotor Connector	
Wire Color	Signal	Signal	Pin	Wire Color	Signal	Signal	Pin
Green/yellow	FG	FG	1	Red	Phase U	Phase U	1
Blue	Phase W	Phase W	2	White	Phase V	Phase V	2
White	Phase V	Phase V	3	Blue	Phase W	Phase W	3
Red	Phase U	Phase U	4	Green/yellow	FG	FG	4
		-	5				
		-	6				

5.2.2 Servomotor Main Circuit Cables for Servomotors with Holding Brakes

Selection Table

Servomotor Model	Length (L)	Order Number* ¹	
		Standard Cable	Flexible Cable* ^{2, 3}
SGM7P-01 100 W	3 m, 5 m, 10 m, 15 m, 20 m, 30 m, 40 m, and 50 m	JZSP-CSM11-□□-E* ⁴	JZSP-CSM31-□□-E* ⁴
SGM7P-02 or -04 200 W or 400 W		JZSP-CSM12-□□-E* ⁴	JZSP-CSM32-□□-E* ⁴
SGM7P-08 750 W		JZSP-CMM10-□□-E	JZSP-CMM11-□□-E
SGM7P-15 1.5 kW		JZSP-CMM30-□□-E	Note: Flexible Cables are not available.

*1. Replace the boxes (□□) in the order number with the cable length (03, 05, 10, 15, 20, 30, 40, or 50).

*2. Use Flexible Cables for moving parts of machines, such as robots.

*3. The recommended bending radius (R) is 90 mm or larger.

*4. The lead installation direction is toward the load. Any other lead installation direction is not allowed.

Note: If the length of the Servomotor Main Circuit Cable exceeds 20 m, the intermittent duty zone in the torque-motor speed characteristics will become smaller because the voltage drop increases.

Appearance

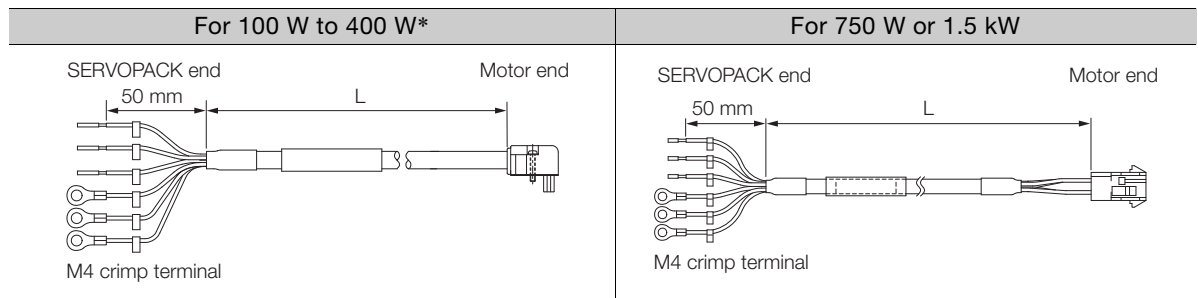

* The lead installation direction is toward the load. Any other lead installation direction is not allowed.

Wiring Specifications

For 100 W to 400 W				For 750 W or 1.5 kW			
SERVOPACK Leads		Servomotor Connector		SERVOPACK Leads		Servomotor Connector	
Wire Color	Signal	Signal	Pin	Wire Color	Signal	Signal	Pin
Green/yellow	FG	FG	1	Red	Phase U	Phase U	1
Blue	Phase W	Phase W	2	White	Phase V	Phase V	2
White	Phase V	Phase V	3	Blue	Phase W	Phase W	3
Red	Phase U	Phase U	4	Green/yellow	FG	FG	4
Black	Brake	Brake	5	Black	Brake	Brake	5
Black	Brake	Brake	6	Black	Brake	Brake	6

Note: There is no polarity for the connection to the holding brake.

5.3 User-Assembled Wiring Materials for Servomotor Main Circuit Cables

5.3.1 Servomotor Connector Kits

Selection Table

Servomotor Model	Servomotor Capacity	Order Number*
SGM7P-01	100 W	JZSP-CSM9-1-E
SGM7P-02 or -04	200 W or 400 W	JZSP-CSM9-2-E
SGM7P-08 or -15	750 W or 1.5 kW	Without Holding Brake: JZSP-CMM9-3-E
		With Holding Brake: JZSP-CSM9-5-E

* Cables are not included. Purchase them separately.

◆ SGM7P-01 (100 W)

Item		Description
Order Number		JZSP-CSM9-1-E
Manufacturer		J.S.T. Mfg. Co., Ltd.
User Instructions		JFA Connector J-1700
Components	Receptacle	J17-06FMH-7KL-1M-CF
	Contacts	SJ1F-01GF-P0.8
Applicable Wire Sizes		AWG20 to AWG24
Applicable Cable Diameter		7 mm ±0.3 mm
Outer Diameter of Insulating Sheath		1.11 mm to 1.53 mm
Mounting Screws		M2 pan-head screws
Crimping Tool*1	Hand Tool	YRS-8841
	Applicator	APLMK SJ1F/MO1-08
External Dimensions [mm]		<p>■ Cable Installed toward Load*2</p>

*1. A Crimping Tool is required. Contact the connector manufacturer for details.

*2. The lead installation direction is toward the load. Any other lead installation direction is not allowed.

Note: Cables are not included. Purchase them separately.

◆ SGM7P-02 or -04 (200 W or 400 W)

Item		Description
Order Number		JZSP-CSM9-2-E
Manufacturer		J.S.T. Mfg. Co., Ltd.
User Instructions		JFA Connector J-2700
Components	Receptacle	J27-06FMH-7KL-1M-CF
	Contacts	SJ2F-01GF-P1.0
Applicable Wire Sizes		AWG20 to AWG24
Applicable Cable Diameter		7 mm ±0.3 mm
Outer Diameter of Insulating Sheath		1.11 mm to 1.53 mm
Mounting Screws		M2 pan-head screws
Crimping Tool*1	Hand Tool	YRS-8861
	Applicator	APLMK SJ2F/MO1-10
External Dimensions [mm]		<p>■ Cable Installed toward Load*2</p>

*1. A Crimping Tool is required. Contact the connector manufacturer for details.

*2. The lead installation direction is toward the load. Any other lead installation direction is not allowed.

Note: Cables are not included. Purchase them separately.

◆ SGM7P-08 or -15 (750 W or 1.5 kW)

■ For Servomotors without Holding Brakes

Item		Description	External Dimensions [mm]
Manufacturer		TE Connectivity Japan G.K.	
Order Number		JZSP-CMM9-3-E	
Components	Cap	350780-1	
	Socket	350550-6	
Applicable Wire Sizes		AWG20 to AWG14	
Crimping Tool*	Hand Tool	90296-2	

* A Crimping Tool is required. Contact the connector manufacturer for details.

Note: Cables are not included. Purchase them separately.

■ For Servomotors with Holding Brakes

Item		Description	External Dimensions [mm]
Manufacturer		TE Connectivity Japan G.K.	
Order Number		JZSP-CSM9-5-E	
Components	Cap	350781-1	
	Socket	Power terminals: 350550-6 Holding brake terminals: 350689-3	
Applicable Wire Sizes		Power terminals: AWG20 to AWG14 Holding brake terminals: AWG24 to AWG18	
Crimping Tool*	Hand Tool	Power terminals: 90296-2 Holding brake terminals: 90300-2	

* A Crimping Tool is required. Contact the connector manufacturer for details.

Note: Cables are not included. Purchase them separately.

5.3.2 Cables without Connectors

Selection Table

Servomotor Model	Servomotor Capacity	Order Number* ¹	
		Standard Cable	Flexible Cable* ^{2, 3}
SGM7P-01 to -04	100 W to 400 W	JZSP-CSM90-□□-E	JZSP-CSM80-□□-E
SGM7P-08 or -15	750 W or 1.5 kW	JZSP-CSM91-□□-E	JZSP-CSM81-□□-E

*1. Replace the boxes (□□) in the order number with the cable length (05, 10, 15, 20, 30, 40, or 50).

*2. Use Flexible Cables for moving parts of machines, such as robots.

*3. The recommended bending radius (R) is 90 mm or larger.

Note: If the length of the Servomotor Main Circuit Cable exceeds 20 m, the intermittent duty zone in the torque-motor speed characteristics will become smaller because the voltage drop increases.

◆ SGM7P-01 to -04 (100 W to 400 W)

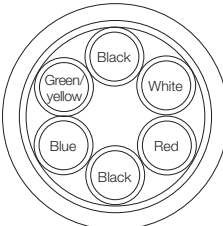
Item	Standard Cable	Flexible Cable
Order Number*	JZSP-CSM90-□□-E (maximum length: 50 m)	JZSP-CSM80-□□-E (maximum length: 50 m)
Specifications	UL2517 (rated temperature: 105°C) AWG20 × 6C	UL2517 (rated temperature: 105°C) AWG22 × 6C
	Power lines: AWG20 (0.52 mm ²) Outer diameter of insulating sheath: 1.53 mm	Power lines: AWG22 (0.33 mm ²) Outer diameter of insulating sheath: 1.37 mm
	Holding brake lines: AWG20 (0.52 mm ²) Outer diameter of insulating sheath: 1.53 mm	Holding brake lines: AWG22 (0.33 mm ²) Outer diameter of insulating sheath: 1.37 mm
Finished Diameter	7 mm ±0.3 mm	
Internal Structure and Lead Colors		

* Replace the boxes (□□) in the order number with the cable length (05, 10, 15, 20, 30, 40, or 50).

◆ SGM7P-08 or -15 (750 W or 1.5 kW)

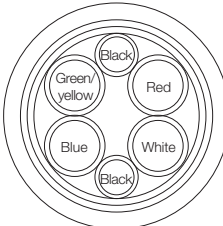
Item	Standard Cable	Flexible Cable
Order Number*	JZSP-CSM91-□□-E (maximum length: 50 m)	JZSP-CSM81-□□-E (maximum length: 50 m)
Specifications	UL2517 (rated temperature: 105°C) AWG16 × 4C or AWG20 × 2C	UL2517 (rated temperature: 105°C) AWG16 × 4C or AWG22 × 2C
	Power lines: AWG16 (1.31 mm ²) Outer diameter of insulating sheath: 2.15 mm	Power lines: AWG16 (1.31 mm ²) Outer diameter of insulating sheath: 2.35 mm
	Holding brake lines: AWG20 (0.52 mm ²) Outer diameter of insulating sheath: 1.6 mm	Holding brake lines: AWG22 (0.33 mm ²) Outer diameter of insulating sheath: 1.37 mm
Finished Diameter	8 mm ±0.3 mm	
Internal Structure and Lead Colors		

* Replace the boxes (□□) in the order number with the cable length (05, 10, 15, 20, 30, 40, or 50).

5.4

Encoder Cables of 20 m or Less

5.4.1

Encoder Cables for Incremental Encoders or Batteryless Absolute Encoders

SGM7P-01 to -04 (for 100 W to 400 W)

◆ Selection Table

Cable Direction	Servomotor Model	Length (L)	Order Number*1	
			Standard Cable	Flexible Cable*2, *3
Load side	SGM7P-01 to -04 100 W to 400 W	3 m, 5 m, 10 m, 15 m, 20 m	JZSP-C7PI0D-□□-E	JZSP-C7PI2D-□□-E
Non-load side			JZSP-C7PI0E-□□-E	JZSP-C7PI2E-□□-E

*1. Replace the boxes (□□) in the order number with the cable length. (03, 05, 10, 15, or 20).

*2. Use Flexible Cables for moving parts of machines, such as robots.

*3. The recommended bending radius (R) is 46 mm or larger.

◆ Appearance

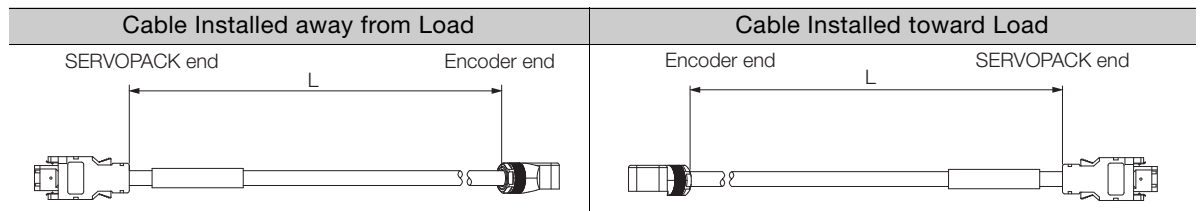

◆ Wiring Specifications

Standard Cable					Flexible Cable				
SERVOPACK end			Encoder (motor) end		SERVOPACK end			Encoder (motor) end	
Pin	Signal		Pin	Wire Color	Pin	Signal		Pin	Wire Color
6	/PS		5	Light blue/white	6	/PS		5	Black/pink
5	PS		4	Light blue	5	PS		4	Red/pink
4	BAT (-)		8	Orange/white	4	BAT (-)		8	Black/light blue
3	BAT (+)		9	Orange	3	BAT (+)		9	Red/light blue
2	PG 0 V		3	Black	2	PG 0 V		3	Light green
1	PG 5 V		6	Red	1	PG 5 V		6	Orange
Shell	FG	Shield wire	Shell	FG	Shell	FG	Shield wire	Shell	FG

SGM7P-08 or -15 (750 W or 1,500 W)

◆ Selection Table

Servomotor Model	Length (L)	Order Number*1	
		Standard Cable	Flexible Cable*2, *3
SGM7P-08 or -15 750 W or 1,500 W	3 m, 5 m, 10 m, 15 m, or 20 m	JZSP-CMP00-□□-E	JZSP-CMP10-□□-E

*1. Replace the boxes (□□) in the order number with the cable length (03, 05, 10, 15, or 20).

*2. Use Flexible Cables for moving parts of machines, such as robots.

*3. The recommended bending radius (R) is 46 mm or larger.

◆ Appearance

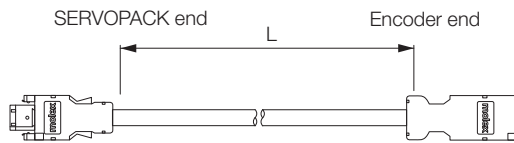

◆ Wiring Specifications

Standard Cable					Flexible Cable				
SERVOPACK end		Encoder (motor) end			SERVOPACK end		Encoder (motor) end		
Pin	Signal	Pin	Wire Color	Pin	Signal	Pin	Wire Color	Pin	Wire Color
6	/PS	6	Light blue/white	6	/PS	6	Black/light blue	6	Black/light blue
5	PS	5	Light blue	5	PS	5	Red/light blue	5	Red/light blue
4	BAT(-)	4	Orange/white	4	BAT(-)	4	Black/pink	4	Black/pink
3	BAT(+)	3	Orange	3	BAT(+)	3	Red/pink	3	Red/pink
2	PG 0 V	2	Black	2	PG 0 V	2	Light green	2	Light green
1	PG 5 V	1	Red	1	PG 5 V	1	Orange	1	Orange
Shell	FG	Shell	FG	Shell	FG	Shell	FG	Shell	FG

5.4.2 Encoder Cables for Absolute Encoders

These cables are equipped with a Battery Case. (A Battery is included.)

Note: If a battery is connected to the host controller, the Battery Case is not required. Use an Encoder Cable for Incremental Encoders or Batteryless Absolute Encoders.

NOTICE

- Install a battery at either the host controller or on the Encoder Cable.
If you install batteries both at the host controller and on the Encoder Cable at the same time, you will create a loop circuit between the batteries, resulting in a risk of damage or burning.

SGM7P-01 to -04 (for 100 W to 400 W)

◆ Selection Table

Cable Direction	Servomotor Model	Length (L)	Order Number*1	
			Standard Cable	Flexible Cable*2, *3
Load side	SGM7P-01 to -04 100 W to 400 W	3 m, 5 m, 10 m, 15 m, 20 m	JZSP-C7PA0D-□□-E	JZSP-C7PA2D-□□-E
Non-load side			JZSP-C7PA0E-□□-E	JZSP-C7PA2E-□□-E

*1. Replace the boxes (□□) in the order number with the cable length. (03, 05, 10, 15, or 20).

*2. Use Flexible Cables for moving parts of machines, such as robots.

*3. The recommended bending radius (R) is 46 mm or large.

◆ Appearance

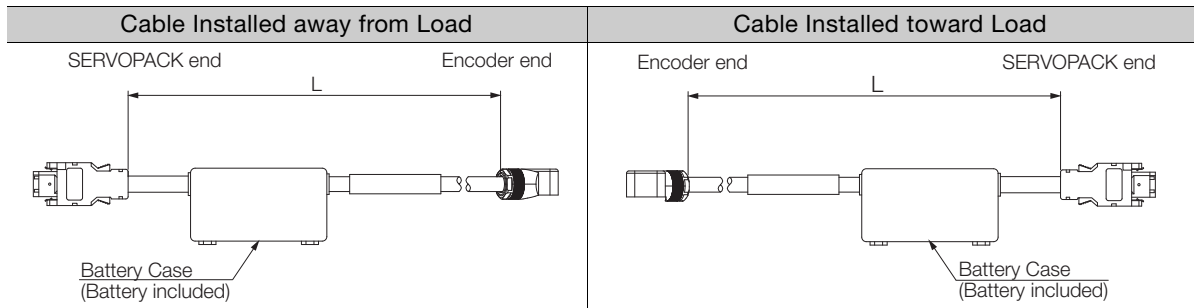

◆ Wiring Specifications

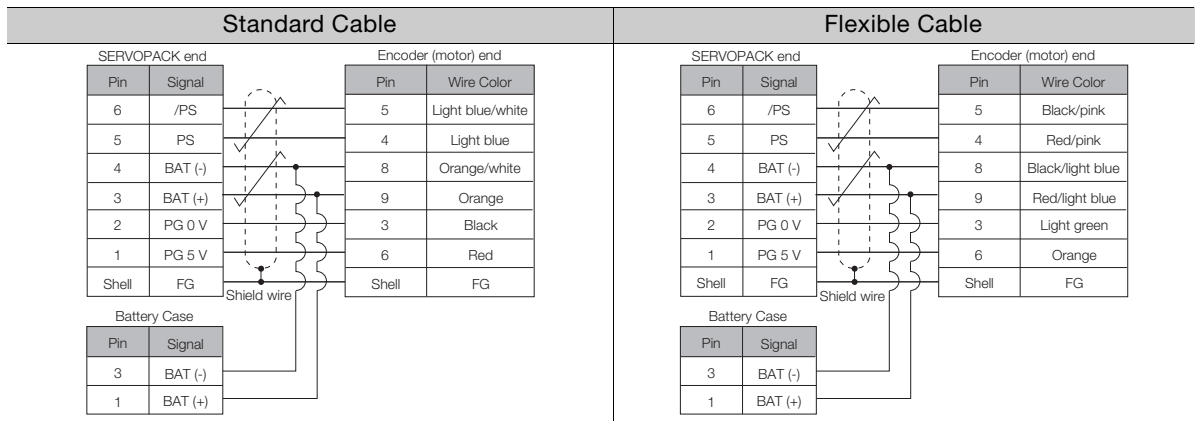

Cables and User-Assembled Wiring Materials for SGM7P Rotary Servomotors

SGM7P-08 or -15 (750 W or 1,500 W)

◆ Selection Table

Servomotor Model	Length (L)	Order Number*1	
		Standard Cable	Flexible Cable*2, *3
SGM7P-08 or -15 750 W or 1,500 W	3 m, 5 m, 10 m, 15 m, or 20 m	JZSP-CSP19-□□-E	JZSP-CSP29-□□-E

*1. Replace the boxes (□□) in the order number with the cable length (03, 05, 10, 15, or 20).

*2. Use Flexible Cables for moving parts of machines, such as robots.

*3. The recommended bending radius (R) is 46 mm or larger.

◆ Appearance

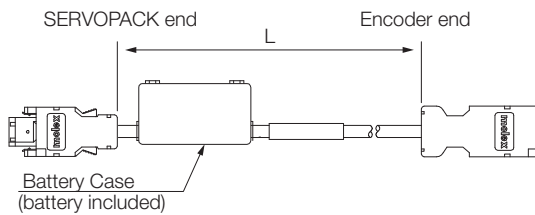

◆ Wiring Specifications

Standard Cable				Flexible Cable			
SERVOPACK end		Encoder (motor) end		SERVOPACK end		Encoder (motor) end	
Pin	Signal	Pin	Wire Color	Pin	Signal	Pin	Wire Color
6	/PS	6	Light blue/white	6	/PS	6	Black/pink
5	PS	5	Light blue	5	PS	5	Red/pink
4	BAT(-)	4	Orange/white	4	BAT(-)	4	Black/light blue
3	BAT(+)	3	Orange	3	BAT(+)	3	Red/light blue
2	PG 0 V	2	Black	2	PG 0 V	2	Light green
1	PG 5 V	1	Red	1	PG 5 V	1	Orange
Shell	FG	Shell	FG	Shell	FG	Shell	FG
Battery Case		Shield wire		Battery Case		Shield wire	
Pin	Signal			Pin	Signal		
3	BAT(-)			3	BAT(-)		
1	BAT(+)			1	BAT(+)		

5.5

Relay Encoder Cable of 30 m to 50 m

If the Encoder Cable length exceeds 20 m, be sure to also use a Motor-End Relay Encoder Cable and a SERVOPACK-End Relay Encoder Cable.

If you use a motor with an absolute encoder and a battery is not mounted to the host controller, also obtain a Relay Encoder Cable with a Battery Case in addition to the above two Cables.

NOTICE

- Install a battery at either the host controller or on the Encoder Cable.
If you install batteries both at the host controller and on the Encoder Cable at the same time, you will create a loop circuit between the batteries, resulting in a risk of damage or burning.

5.5.1

Motor-End Relay Encoder Cables

Note: This cable is not required if you use a SGM7P-08 or -15 (for 750 W, 1.5 kW).

Selection Table

Specification	Length (L)	Order Number
Used for all types of encoders.	0.3 m	JZSP-C7PRCD-E

Appearance

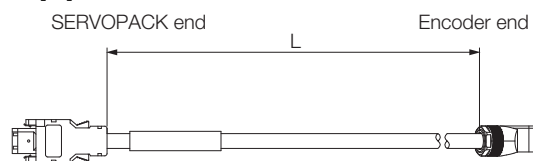

Wiring Specifications

SERVOPACK end		Encoder (motor) end	
Pin	Signal	Pin	Wire Color
6	/PS	5	Light blue/white
5	PS	4	Light blue
4	BAT (-)	8	Orange/white
3	BAT (+)	9	Orange
2	PG 0 V	3	Black
1	PG 5 V	6	Red
Shell	FG	Shell	FG

Shield wire

5.5.2

SERVOPACK-End Relay Encoder Cables

Selection Table

Specification	Length (L)	Order Number*
Used for all types of encoders.	30 m, 40 m, or 50 m	JZSP-UCMP00-□□-E

* Replace the boxes (□□) in the order number with the cable length (30, 40, or 50).

5.5.3 Relay Encoder Cables with Battery Cases

Appearance

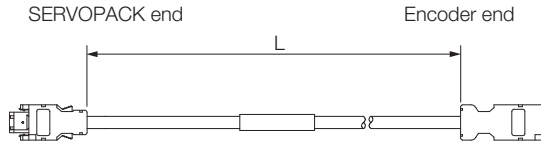

Wiring Specifications

SERVOPACK end		Encoder (motor) end	
Pin	Signal	Pin	Wire Color
6	/PS	6	Light blue/white
5	PS	5	Light blue
4	BAT (-)	4	Orange/white
3	BAT (+)	3	Orange
2	PG 0 V	2	Black
1	PG 5 V	1	Red
Shell	FG	Shell	FG

Shield wire

5.5.3 Relay Encoder Cables with Battery Cases

Note: This Cable is not required if you use a Servomotor with an Incremental Encoder, use a Servomotor with a Batteryless Absolute Encoder, or connect a battery to the host controller.

Selection Table

Length (L)	Order Number
0.3 m	JZSP-CSP12-E

Appearance

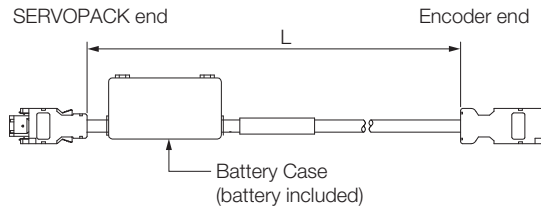

Wiring Specifications

SERVOPACK end		Encoder (motor) end	
Pin	Signal	Pin	Wire Color
6	/PS	6	Light blue/white
5	PS	5	Light blue
4	BAT (-)	4	Orange/white
3	BAT (+)	3	Orange
2	PG 0 V	2	Black
1	PG 5 V	1	Red
Shell	FG	Shell	FG

Shield wire

Battery Case	
Pin	Signal
3	BAT (-)
1	BAT (+)

5.6 User-Assembled Wiring Materials for Encoder Cables

5.6.1 Precautions When Using Encoder Cables with a Wiring Length of 30 m to 50 m

When using Encoder Cables with a wiring length of 30 m to 50 m, it is necessary to fabricate different types of cables depending on the Servomotor model.

Cables to be Fabricated	Servomotor Model SGM7P		Connectors and Wire Materials Required for Fabrication	Reference Page	Remarks
	-01 to -04	-08, -15			
Motor-End Relay Encoder Cable	Fabrication required	Fabrication not required	SERVOPACK Connector	5.6.2 <i>SERVOPACK Connector Kits</i> on page 5-15	This cable should be 0.3 m or less.
			Servomotor Connector	5.6.3 <i>Encoder Connector Kits</i> on page 5-16	
			Encoder Cable (20 m or less)	5.6.4 <i>Cables without Connectors</i> on page 5-17	
SERVOPACK-End Relay Encoder Cable	Fabrication required	Fabrication required	SERVOPACK Connector	5.6.2 <i>SERVOPACK Connector Kits</i> on page 5-15	This cable should be 50 m or less.
			Cable Relay Connector	5.6.3 <i>Encoder Connector Kits</i> on page 5-16	
			Relay Encoder Cable (30 m to 50 m)	5.6.4 <i>Cables without Connectors</i> on page 5-17	

Refer to the following section for details on the connection of the Relay Encoder Cable.

 5.1 *Cable Configurations* on page 5-2

5.6.2 SERVOPACK Connector Kits

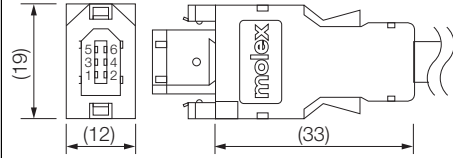
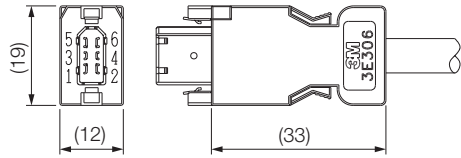
Type	Standard Connector Kit	Compatible Connector Kit
Inquiries	Yaskawa representative	3M Japan Limited
Manufacturer	Molex Incorporated	
Order Number	JZSP-CMP9-1-E	
Specifications	55100-0670 (soldered) Product specifications: PS-54280	Receptacle: 3E206-0100 KV (soldered) Shell Kit: 3E306-3200-008 Product specifications: JNPS-1042 and JNPS-1043
External Dimensions [mm]		

Note: Cables are not included. Purchase them separately.

5.6.3 Encoder Connector Kits

SGM7P-01 to -04 (100 W to 400 W)

◆ Servomotor Connectors

Order Number	JZSP-C7P9-1-E	
Manufacturer	Molex Incorporated	
Components	504678-0070 Loose Connectors: 56161-8181 (crimped), Reeled: 56161-8081 (crimped)	
Applicable Wire Sizes	AWG22 to AWG26	
Applicable Cable Diameter	6.3 mm to 7.7 mm	
Outer Diameter of Insulating Sheath	1.05 mm to 1.4 mm	
Mounting Screws	M2 pan-head screws (two)	
Application Specifications	AS-504682	
Crimping Specifications	CS-56161	
Crimping Tool*	Hand Tool	57175-5000
Shell Caulking Tool	57331-5100	

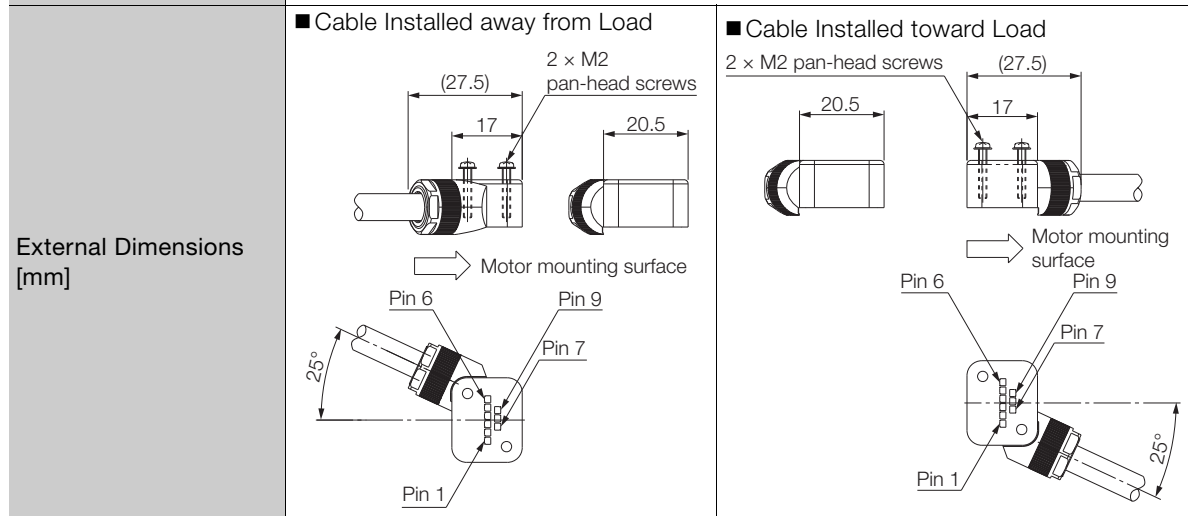

* A Crimping Tool is required. When using other wire sizes, contact the connector manufacturer for crimping tools.

Note: Cables are not included. Purchase them separately.

All models

◆ Cable Relay Connector

Order Number	JZSP-CMP9-2-E
Manufacturer	Molex Incorporated
Components	54280-0609 (soldered)
Product Specifications	PS-54280

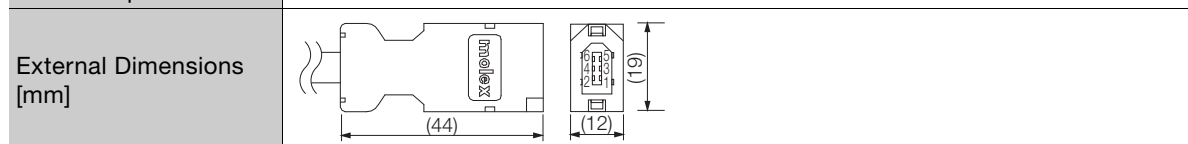

Note: Cables are not included. Purchase them separately.

5.6.4 Cables without Connectors

Encoder Cables of 20 m or Less

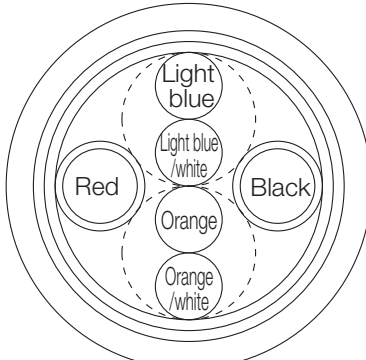
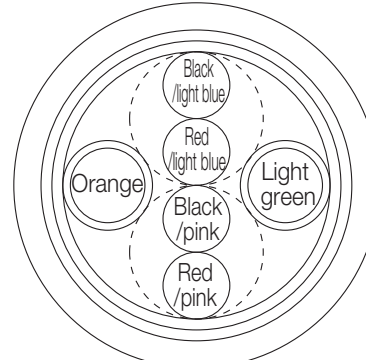
Item	Standard Cable (20 m max.)	Flexible Cable (20 m max.)
Order Number*	JZSP-CMP09-□□-E	JZSP-CSP39-□□-E
Specifications	UL20276 (rated temperature: 80°C) AWG22 × 2C + AWG24 × 2P	UL20276 (rated temperature: 80°C) AWG22 × 2C + AWG24 × 2P
	AWG22 (0.33 mm ²) Outer diameter of insulating sheath: 1.15 mm	AWG22 (0.33 mm ²) Outer diameter of insulating sheath: 1.35 mm
	AWG24 (0.20 mm ²) Outer diameter of insulating sheath: 1.09 mm	AWG24 (0.20 mm ²) Outer diameter of insulating sheath: 1.21 mm
Finished Diameter	6.5 mm	6.8 mm
Internal Structure and Lead Colors		

* Replace the boxes (□□) in the order number with the cable length (05, 10, 15, or 20).

Relay Encoder Cable of 30 m to 50 m

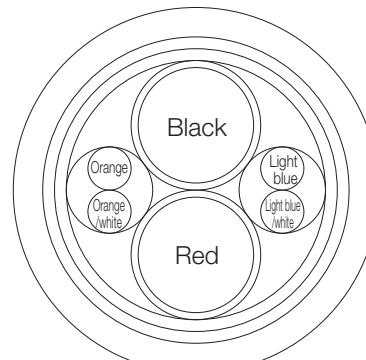
Item	Standard Cable
Order Number*	JZSP-CMP19-□□-E (maximum length: 50 m)
Specifications	UL20276 (rated temperature: 80°C) AWG16 × 2C + AWG26 × 2P
	AWG16 (1.31 mm ²) Outer diameter of insulating sheath: 2.0 mm
	AWG26 (0.13 mm ²) Outer diameter of insulating sheath: 0.91 mm
Finished Diameter	6.8 mm
Internal Structure and Lead Colors	

* Replace the boxes (□□) in the order number with the cable length (30, 40, or 50).

5.7 Wiring Precautions

The wiring precautions are the same as for SGM7M Rotary Servomotors. Refer to the following section.

 *2.5 Wiring Precautions* on page 2-9

Cables and User-Assembled Wiring Materials for SGM7G Rotary Servomotors

6

6.1	Cable Configurations	6-3
6.1.1	SGM7G-03 and -05 (300 W and 450 W)	6-3
6.1.2	SGM7G-09 to -1E (850 W to 15 kW)	6-4
6.2	Servomotor Main Circuit Cables	6-5
6.2.1	Servomotor Main Circuit Cables for Servomotors without Holding Brakes	6-5
6.2.2	Servomotor Main Circuit Cables for Servomotors with Holding Brakes	6-7
6.3	User-Assembled Wiring Materials for Servomotor Main Circuit Cables: SGM7G-03, -05 . . .	6-11
6.3.1	Servomotor Connector Kits	6-11
6.3.2	Wiring Materials	6-11
6.4	User-Assembled Wiring Materials for Servomotor Main Circuit Cables: SGM7G-09 to -1E . .	6-12
6.4.1	Connector Structures	6-12
6.4.2	Main Power Supply Terminal	6-13
6.4.3	Holding Brake Terminals	6-14
6.4.4	Connector External Dimensions	6-16
6.5	Encoder Cables of 20 m or Less	6-20
6.5.1	Encoder Cables for Incremental Encoders or Batteryless Absolute Encoders	6-20
6.5.2	Encoder Cables for Absolute Encoders	6-21
6.6	Relay Encoder Cables of 30 m to 50 m . . .	6-22
6.6.1	Motor-End Relay Encoder Cables	6-22
6.6.2	SERVOPACK-End Relay Encoder Cables	6-22
6.6.3	Relay Encoder Cables with Battery Cases	6-23

6.7 User-Assembled Wiring Materials for Encoder Cables . . 6-24

- 6.7.1 Precautions When Using Encoder Cables with a
Wiring Length of 30 m to 50 m 6-24
- 6.7.2 SERVOPACK Connector Kits 6-24
- 6.7.3 Encoder Connector Kits 6-25
- 6.7.4 Cables without Connectors 6-26

6.8 Wiring Precautions 6-27

6.1 Cable Configurations

6.1.1 SGM7G-03 and -05 (300 W and 450 W)

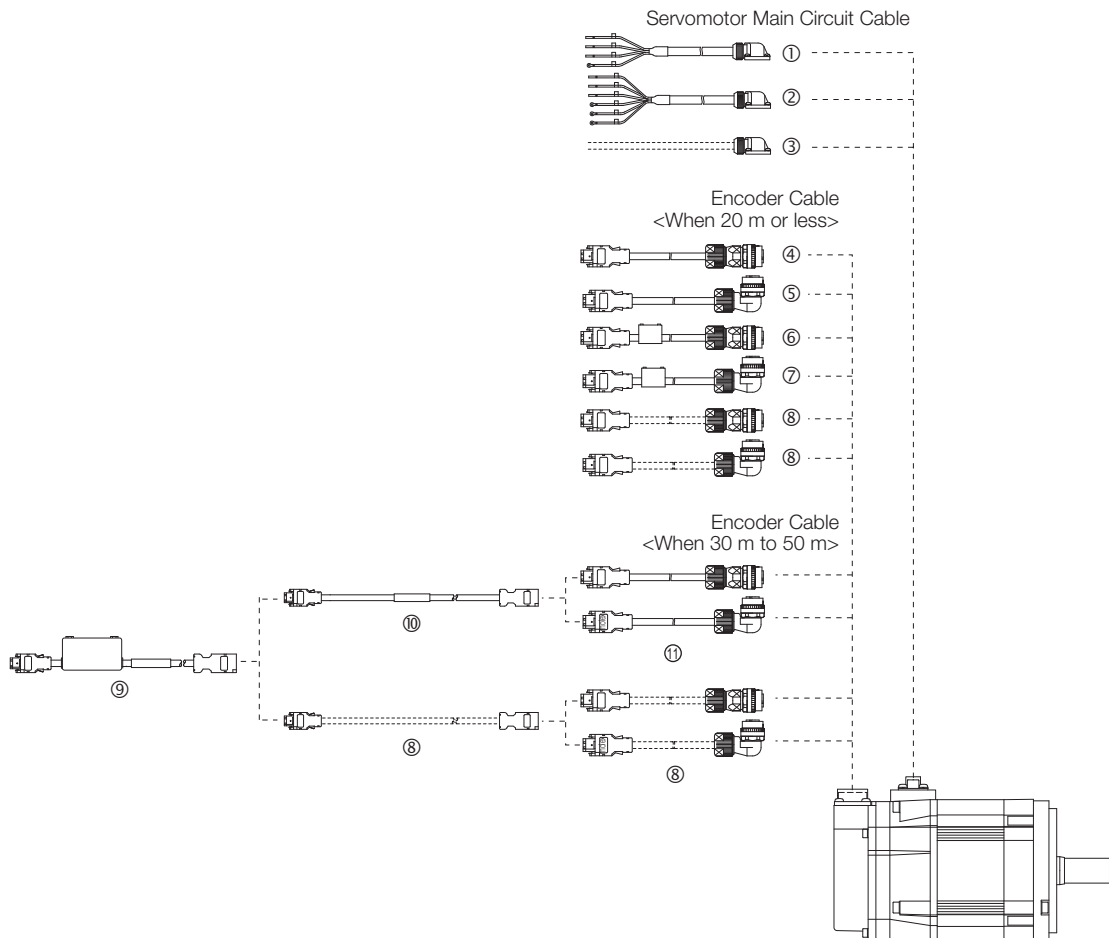

Note: If the Encoder Cable length exceeds 20 m, be sure to also connect Relay Encoder Cables as shown at ⑧ to ⑪ in the above diagram.

No.	Cable Type	Reference
①	Servomotor Main Circuit Cables* ¹	For Servomotors without Holding Brakes
②		For Servomotors with Holding Brakes
③	User-Assembled Wiring Materials for Servomotor Main Circuit Cables* ¹	Connectors
		Cables without Connectors
④	Encoder Cables of 20 m or Less for Incremental Encoders or Batteryless Absolute Encoders	Straight Plug
⑤		Right-Angle Plug* ²
⑥	Encoder Cables of 20 m or Less with Battery Cases for Absolute Encoders* ³	Straight Plug
⑦		Right-Angle Plug* ²
⑧	User-Assembled Wiring Materials for Encoder Cables* ⁴	Connectors
		Cables without Connectors
⑨	Relay Encoder Cables with Battery Cases* ⁵	page 6-22
⑩	SERVOPACK-End Relay Encoder Cables	
⑪	Motor-End Relay Encoder Cables	

*1. The lead installation direction is away from the load. Consult your Yaskawa representative for lead installation toward the load.

*2. The lead installation direction is away from the load. Consult your Yaskawa representative for other lead installation directions.

*3. If a battery is connected to the host controller, the Battery Case is not required. Use an Encoder Cable for Incremental Encoders or Batteryless Absolute Encoders.

*4. When you fabricate the Encoder Cable, always connect the shield wire from the Encoder Cable to the connector (shell). There is a risk of failure or malfunction.

*5. This Cable is not required if you use a Servomotor with an Incremental Encoder, use a Servomotor with a Batteryless Absolute Encoder, or connect a battery to the host controller.

6.1.2 SGM7G-09 to -1E (850 W to 15 kW)

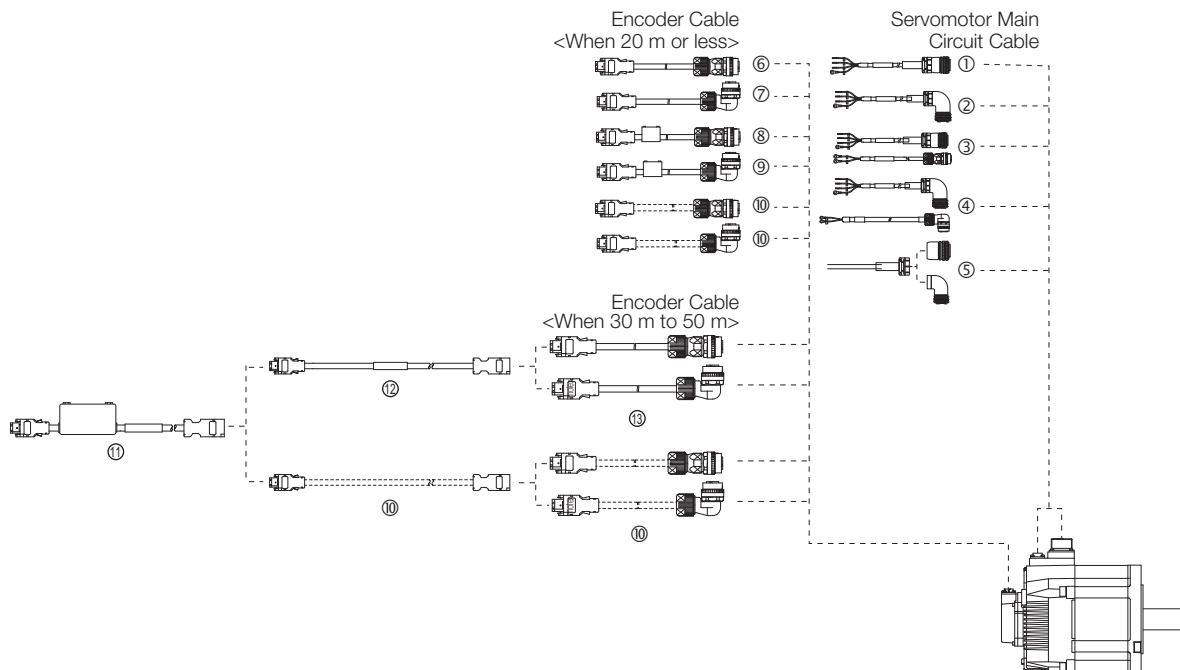

Note: If the Encoder Cable length exceeds 20 m, be sure to also connect Relay Encoder Cables as shown at ⑩ to ⑬ in the above diagram.

No.	Cable Type		Reference
①	Servomotor Main Circuit Cables for Servomotors without Holding Brakes*1	Straight Plug	page 6-5
②		Right-Angle Plug*2	
③	Servomotor Main Circuit Cables for Servomotors with Holding Brakes*1	Straight Plug	page 6-7
④		Right-Angle Plug*2	
⑤	User-Assembled Wiring Materials for Servomotor Main Circuit Cables	Connectors	page 6-12
		Cables without Connectors*3	-
⑥	Encoder Cables of 20 m or Less for Incremental Encoders or Batteryless Absolute Encoders	Straight Plug	page 6-20
⑦		Right-Angle Plug	
⑧	Encoder Cables of 20 m or Less with Battery Cases for Absolute Encoders*4	Straight Plug	page 6-21
⑨		Right-Angle Plug	
⑩	User-Assembled Wiring Materials for Encoder Cables*5	Connectors	page 6-24
		Cables without Connectors	page 6-26
⑪	Relay Encoder Cables with Battery Cases*6		page 6-22
⑫	SERVOPACK-End Relay Encoder Cables		
⑬	Motor-End Relay Encoder Cables		

*1. Cables with connectors on both ends that are compliant with an IP67 protective structure and European Safety Standards are not available from Yaskawa. Fabricate the cables by yourself or consult your Yaskawa representative. To fabricate the cables, refer to the following section.

 6.4 User-Assembled Wiring Materials for Servomotor Main Circuit Cables: SGM7G-09 to -1E on page 6-12

*2. The lead installation direction is away from the load. Consult your Yaskawa representative for other lead installation directions.

*3. Yaskawa does not specify what wiring materials to use for the Servomotor Main Circuit Cables. Use appropriate wiring materials for the current specifications and connectors.

*4. If a battery is connected to the host controller, the Battery Case is not required. Use an Encoder Cable for Incremental Encoders or Batteryless Absolute Encoders.

*5. When you fabricate the Encoder Cable, always connect the shield wire from the Encoder Cable to the connector (shell). There is a risk of failure or malfunction.

*6. This Cable is not required if you use a Servomotor with an Incremental Encoder, use a Servomotor with a Batteryless Absolute Encoder, or connect a battery to the host controller.

6.2

Servomotor Main Circuit Cables

6.2.1

Servomotor Main Circuit Cables for Servomotors without Holding Brakes

Selection Table

◆ SGM7G-03 or -05 (300 W or 450 W)

Servomotor Model	Length (L)	Order Number* ¹
		Standard (Flexible) Cable* ²
SGM7G-03 or -05 300 W or 450 W	3 m, 5 m, 10 m, 15 m, 20 m, 30 m, 40 m, and 50 m	JZSP-CVM21-□□-E* ³

*1. Replace the boxes (□□) in the order number with the cable length (03, 05, 10, 15, 20, 30, 40, or 50).

*2. These Standard Cables are Flexible Cables. The recommended bending radius (R) is 90 mm or larger.

*3. The lead installation direction is away from the load. Consult your Yaskawa representative for lead installation toward the load.

Note: If the length of the Servomotor Main Circuit Cable exceeds 20 m, the intermittent duty zone in the torque-motor speed characteristics will become smaller because the voltage drop increases.

◆ SGM7G-09 to -1E (850 W to 15 kW)

Note: Cables with connectors on both ends that are compliant with an IP67 protective structure and European Safety Standards are not available from Yaskawa. Fabricate the cables by yourself or consult your Yaskawa representative.

To fabricate the cables, refer to the following section.

 6.4 User-Assembled Wiring Materials for Servomotor Main Circuit Cables: SGM7G-09 to -1E on page 6-12

Servomotor Model	Connector Type	Length (L)	Order Number* ¹	
			Standard Cable	Flexible Cable* ^{2, *3}
SGM7G-09 or -13 850 W or 1.3 kW	Straight	3 m, 5 m, 10 m, 15 m, and 20 m	JZSP-UVA101-□□-E	JZSP-UVA121-□□-E
	Right-angle* ⁴		JZSP-UVA102-□□-E	JZSP-UVA122-□□-E
SGM7G-20 1.8 kW	Straight		JZSP-UVA301-□□-E	JZSP-UVA321-□□-E
	Right-angle* ⁴		JZSP-UVA302-□□-E	JZSP-UVA322-□□-E
SGM7G-30 2.4 kW (When used in combination with the SGD7S-200A)	Straight		JZSP-UVA601-□□-E	JZSP-UVA621-□□-E
	Right-angle* ⁴		JZSP-UVA602-□□-E	JZSP-UVA622-□□-E
SGM7G-30 or -44 2.9 kW or 4.4 kW	Straight		JZSP-UVA701-□□-E	JZSP-UVA721-□□-E
	Right-angle* ⁴		JZSP-UVA702-□□-E	JZSP-UVA722-□□-E
SGM7G-55 or -75 5.5 kW or 7.5 kW	Straight		JZSP-UVAA01-□□-E	JZSP-UVAA21-□□-E
	Right-angle* ⁴		JZSP-UVAA02-□□-E	JZSP-UVAA22-□□-E
SGM7G-1A or -1E 11 kW or 15 kW	Straight		JZSP-UVAB01-□□-E	JZSP-UVAB21-□□-E
	Right-angle* ⁴		JZSP-UVAB02-□□-E	JZSP-UVAB22-□□-E

*1. Replace the boxes (□□) in the order number with the cable length (03, 05, 10, 15, or 20).

*2. Use Flexible Cables for moving parts of machines, such as robots.

*3. The recommended bending radius (R) is 90 mm or larger.

*4. The lead installation direction is away from the load. Consult your Yaskawa representative for other lead installation directions.

Appearance

◆ SGM7G-03 and -05 (for 300 W and 450 W)

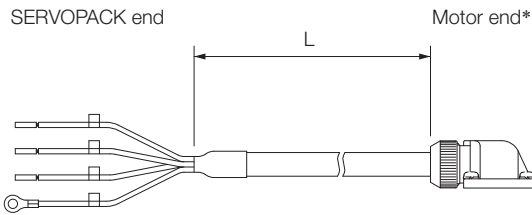

* The lead installation direction is away from the load. Consult your Yaskawa representative for lead installation toward the load.

◆ SGM7G-09 to -1E (for 850 W to 15 kW)

Note: Cables with connectors on both ends that are compliant with an IP67 protective structure and European Safety Standards are not available from Yaskawa. Fabricate the cables by yourself or consult your Yaskawa representative.

To fabricate the cables, refer to the following section.

🔧 6.4 User-Assembled Wiring Materials for Servomotor Main Circuit Cables: SGM7G-09 to -1E on page 6-12

Servomotor Model	Straight Connector	Right-Angle Connector*
SGM7G-09, -13 850 W, 1.3 kW		
SGM7G-20 to 1E 1.8 kW to 15 kW		

* The lead installation direction is away from the load. Consult your Yaskawa representative for other lead installation directions.

Wiring Specifications

SGM7G-03 and -05 (for 300 W and 450 W)				SGM7G-09 to -1E (for 850 W to 15 kW)			
SERVOPACK Leads		Servomotor Connector		SERVOPACK Leads		Servomotor Connector	
Wire Color	Signal	Signal	Pin	Wire Color	Signal	Signal	Pin
Green/yellow	FG	FG	PE	Red	Phase U	Phase U	A
-	-	-	5	White	Phase V	Phase V	B
-	-	-	4	Black or blue	Phase W	Phase W	C
Red	Phase U	Phase U	3	Green or green/yellow	FG	FG	D
White	Phase V	Phase V	2				
Blue	Phase W	Phase W	1				

6.2.2 Servomotor Main Circuit Cables for Servomotors with Holding Brakes

Selection Table

◆ SGM7G-03 or -05 (300 W or 450 W)

Servomotor Model	Length (L)	Order Number* ¹
		Standard (Flexible) Cable* ²
SGM7G-03 or -05 300 W or 450 W	3 m, 5 m, 10 m, 15 m, 20 m, 30 m, 40 m, and 50 m	JZSP-CVM41-□□-E* ³

*1. Replace the boxes (□□) in the order number with the cable length (03, 05, 10, 15, 20, 30, 40, or 50).

*2. These Standard Cables are Flexible Cables. The recommended bending radius (R) is 90 mm or larger.

*3. The lead installation direction is away from the load. Consult your Yaskawa representative for lead installation toward the load.

Note: If the length of the Servomotor Main Circuit Cable exceeds 20 m, the intermittent duty zone in the torque-motor speed characteristics will become smaller because the voltage drop increases.

◆ SGM7G-09 to -1E (850 W to 15 kW)

Note: Cables with connectors on both ends that are compliant with an IP67 protective structure and European Safety Standards are not available from Yaskawa. Fabricate the cables by yourself or consult your Yaskawa representative.

To fabricate the cables, refer to the following section.

 **6.4 User-Assembled Wiring Materials for Servomotor Main Circuit Cables: SGM7G-09 to -1E on page 6-12**

Servomotor Model	Connector Specifications	Length (L)	Order Number* ^{1, *2}	
			Set of Two Cables (Main Power Supply Cable and Holding Brake Cable)	
			Standard Cable	Flexible Cable* ^{3, *4}
SGM7G-09 or -13 850 W or 1.3 kW	Straight	3 m, 5 m, 10 m, 15 m, and 20 m	JZSP-UVA131-□□-E	JZSP-UVA141-□□-E
	Right-angle* ⁵		JZSP-UVA132-□□-E	JZSP-UVA142-□□-E
SGM7G-20 1.8 kW	Straight		JZSP-UVA331-□□-E	JZSP-UVA341-□□-E
	Right-angle* ⁵		JZSP-UVA332-□□-E	JZSP-UVA342-□□-E
SGM7G-30 2.4 kW (When used in combination with the SGD7S-200A)	Straight		JZSP-UVA631-□□-E	JZSP-UVA641-□□-E
	Right-angle* ⁵		JZSP-UVA632-□□-E	JZSP-UVA642-□□-E
SGM7G-30 or -44 2.9 kW or 4.4 kW	Straight		JZSP-UVA731-□□-E	JZSP-UVA741-□□-E
	Right-angle* ⁵		JZSP-UVA732-□□-E	JZSP-UVA742-□□-E
SGM7G-55 or -75 5.5 kW or 7.5 kW	Straight		JZSP-UVAA31-□□-E	JZSP-UVAA41-□□-E
	Right-angle* ⁵		JZSP-UVAA32-□□-E	JZSP-UVAA42-□□-E
SGM7G-1A or -1E 11 kW or 15 kW	Straight		JZSP-UVAB31-□□-E	JZSP-UVAB41-□□-E
	Right-angle* ⁵		JZSP-UVAB32-□□-E	JZSP-UVAB42-□□-E

*1. Replace the boxes (□□) in the order number with the cable length (03, 05, 10, 15, or 20).

*2. Refer to the following section to obtain Main Circuit Power Supply Cables and Holding Brake Cables individually.

 **Appearance on page 6-8**

*3. Use Flexible Cables for moving parts of machines, such as robots.

*4. The recommended bending radius (R) is 90 mm or larger.

*5. The lead installation direction is away from the load. Consult your Yaskawa representative for other lead installation directions.

Appearance

◆ SGM7G-03 and -05 (for 300 W and 450 W)

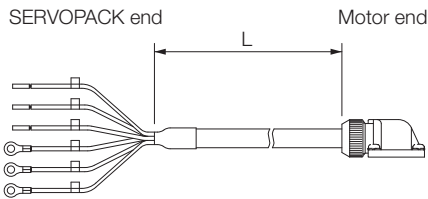

* The lead installation direction is away from the load. Consult your Yaskawa representative for lead installation toward the load.

◆ SGM7G-09 to -1E (for 850 W to 15 kW)

Servomotor Model	Connector Type	Appearance	Order Numbers of Main Power Supply Cable and Holding Brake Cable	Individual Cable Order Numbers
SGM7G-09 or -13 850 W or 1.3 kW	Straight	<p>SERVOPACK end Motor end</p> <p>Brake power supply end Brake end</p> <p>Length L is shown between the main cable ends.</p>	Standard Cable: JZSP-UVA131-□□-E Flexible Cable: JZSP-UVA141-□□-E	<ul style="list-style-type: none"> Main Circuit Power Supply Cable Standard Cable: JZSP-UVA101-□□-E Flexible Cable: JZSP-UVA121-□□-E Holding Brake Cable*2 JZSP-U7B23-□□-E
	Right-angle*1	<p>SERVOPACK end Motor end</p> <p>Brake power supply end Brake end</p> <p>Length L is shown between the main cable ends.</p>	Standard Cable: JZSP-UVA132-□□-E Flexible Cable: JZSP-UVA142-□□-E	<ul style="list-style-type: none"> Main Circuit Power Supply Cable Standard Cable: JZSP-UVA102-□□-E Flexible Cable: JZSP-UVA122-□□-E Holding Brake Cable*2 JZSP-U7B24-□□-E
SGM7G-20 1.8 kW	Straight	<p>SERVOPACK end Motor end</p> <p>Brake power supply end Brake end</p> <p>Length L is shown between the main cable ends.</p>	Standard Cable: JZSP-UVA331-□□-E Flexible Cable: JZSP-UVA341-□□-E	<ul style="list-style-type: none"> Main Circuit Power Supply Cable Standard Cable: JZSP-UVA301-□□-E Flexible Cable: JZSP-UVA321-□□-E Holding Brake Cable*2 JZSP-U7B23-□□-E
	Right-angle*1	<p>SERVOPACK end Motor end</p> <p>Brake power supply end Brake end</p> <p>Length L is shown between the main cable ends.</p>	Standard Cable: JZSP-UVA332-□□-E Flexible Cable: JZSP-UVA342-□□-E	<ul style="list-style-type: none"> Main Circuit Power Supply Cable Standard Cable: JZSP-UVA302-□□-E Flexible Cable: JZSP-UVA322-□□-E Holding Brake Cable*2 JZSP-U7B24-□□-E

Continued on next page.

*1. The lead installation direction is away from the load. Consult your Yaskawa representative for other lead directions.

*2. Flexible Cables are provided as a standard feature.

6.2.2 Servomotor Main Circuit Cables for Servomotors with Holding Brakes

Continued from previous page.

Servomotor Model	Connector Type	Appearance	Order Numbers of Main Power Supply Cable and Holding Brake Cable	Individual Cable Order Numbers
SGM7G-30 2.4 kW (When used in combination with the SGD7S-200A)	Straight		Standard Cable: JZSP-UVA631-□□-E Flexible Cable: JZSP-UVA641-□□-E	<ul style="list-style-type: none"> Main Circuit Power Supply Cable Standard Cable: JZSP-UVA601-□□-E Flexible Cable: JZSP-UVA621-□□-E Holding Brake Cable*² JZSP-U7B23-□□-E
	Right-angle* ¹		Standard Cable: JZSP-UVA632-□□-E Flexible Cable: JZSP-UVA642-□□-E	<ul style="list-style-type: none"> Main Circuit Power Supply Cable Standard Cable: JZSP-UVA602-□□-E Flexible Cable: JZSP-UVA622-□□-E Holding Brake Cable*² JZSP-U7B24-□□-E
SGM7G-30 or -44 2.9 kW or 4.4 kW	Straight		Standard Cable: JZSP-UVA731-□□-E Flexible Cable: JZSP-UVA741-□□-E	<ul style="list-style-type: none"> Main Circuit Power Supply Cable Standard Cable: JZSP-UVA701-□□-E Flexible Cable: JZSP-UVA721-□□-E Holding Brake Cable*² JZSP-U7B23-□□-E
	Right-angle* ¹		Standard Cable: JZSP-UVA732-□□-E Flexible Cable: JZSP-UVA742-□□-E	<ul style="list-style-type: none"> Main Circuit Power Supply Cable Standard Cable: JZSP-UVA702-□□-E Flexible Cable: JZSP-UVA722-□□-E Holding Brake Cable*² JZSP-U7B24-□□-E

Continued on next page.

*1. The lead installation direction is away from the load. Consult your Yaskawa representative for other lead directions.

*2. Flexible Cables are provided as a standard feature.

Continued from previous page.

Servomotor Model	Connector Type	Appearance	Order Numbers of Main Power Supply Cable and Holding Brake Cable	Individual Cable Order Numbers
SGM7G-55 or -75 5.5 kW or 7.5 kW	Straight		Standard Cable: JZSP-UVAA31-□□-E Flexible Cable: JZSP-UVAA41-□□-E	<ul style="list-style-type: none"> Main Circuit Power Supply Cable Standard Cable: JZSP-UVAA01-□□-E Flexible Cable: JZSP-UVAA21-□□-E Holding Brake Cable*² JZSP-U7B23-□□-E
	Right-angle* ¹		Standard Cable: JZSP-UVAA32-□□-E Flexible Cable: JZSP-UVAA42-□□-E	<ul style="list-style-type: none"> Main Circuit Power Supply Cable Standard Cable: JZSP-UVAA02-□□-E Flexible Cable: JZSP-UVAA22-□□-E Holding Brake Cable*² JZSP-U7B24-□□-E
SGM7G-1A or -1E 11 kW or 15 kW	Straight		Standard Cable: JZSP-UVAB31-□□-E Flexible Cable: JZSP-UVAB41-□□-E	<ul style="list-style-type: none"> Main Circuit Power Supply Cable Standard Cable: JZSP-UVAB01-□□-E Flexible Cable: JZSP-UVAB21-□□-E Holding Brake Cable*² JZSP-U7B23-□□-E
	Right-angle* ¹		Standard Cable: JZSP-UVAB32-□□-E Flexible Cable: JZSP-UVAB42-□□-E	<ul style="list-style-type: none"> Main Circuit Power Supply Cable Standard Cable: JZSP-UVAB02-□□-E Flexible Cable: JZSP-UVAB22-□□-E Holding Brake Cable*² JZSP-U7B24-□□-E

*1. The lead installation direction is away from the load. Consult your Yaskawa representative for other lead directions.

*2. Flexible Cables are provided as a standard feature.

Wiring Specifications

SGM7G-03 and -05 (for 300 W and 450 W)				SGM7G-09 to -1E (for 850 W to 15 kW)			
SERVOPACK Leads		Servomotor Connector		SERVOPACK Leads		Servomotor Connector	
Wire Color	Signal	Signal	Pin	Wire Color	Signal	Signal	Pin
Green/yellow	FG	FG	PE	Red	Phase U	Phase U	A
Black	Brake	Brake	5	White	Phase V	Phase V	B
Black	Brake	Brake	4	Black or blue	Phase W	Phase W	C
Red	Phase U	Phase U	3	Green or green/yellow	FG	FG	D
White	Phase V	Phase V	2				
Blue	Phase W	Phase W	1	Black	Brake	Brake	1
				White	Brake	Brake	2

Note: There is no polarity for the connection to the brake.

6.3

User-Assembled Wiring Materials for Servomotor Main Circuit Cables: SGM7G-03, -05

6.3.1 Servomotor Connector Kits

Item		Description	External Dimensions [mm]
Order Number		JZSP-CVM9-1-E	<p>• Pin layout For cable installed away from load</p> <p>For cable installed toward load</p>
Manufacturer		Japan Aviation Electronics Industry, Ltd.	
User Instructions		J AHL-50020	
Components	Plug	JNYFX06SJ3	
	Contacts	ST-TMH-S-C1B	
Applicable Wire Sizes		AWG18 to AWG22	
Applicable Cable Diameter		6.9 mm to 8.3 mm	
Outer Diameter of Insulating Sheath		1.3 mm to 1.8 mm	
Mounting Screws		M3 pan-head screws	
Crimping Tool*	Hand Tool	CT170-14-TMH5B	

* A Crimping Tool is required. Contact the connector manufacturer for details.

Note: Cables are not included. Purchase them separately.

6.3.2 Wiring Materials

Item	For Servomotors without Holding Brakes (4 Wires)	For Servomotors with Holding Brakes (6 Wires)
Order Number*	JZSP-CVM29-□□-E (maximum length: 50 m)	JZSP-CVM49-□□-E (maximum length: 50 m)
Specifications	UL2586 (rated temperature: 105°C) AWG20 × 4C	UL2586 (rated temperature: 105°C) AWG20 × 6C
	Power lines: AWG20 (0.52 mm ²) Outer diameter of insulating sheath: 1.77 mm	Power lines: AWG20 (0.52 mm ²) Outer diameter of insulating sheath: 1.77 mm
Finished Diameter	7.3 mm ±0.3 mm	7.3 mm ±0.3 mm
Internal Structure and Lead Colors		

* Replace the boxes (□□) in the order number with the cable length (03, 05, 10, 15, 20, 30, 40, or 50).

Note: These are Flexible Cables.

6.4 User-Assembled Wiring Materials for Servomotor Main Circuit Cables: SGM7G-09 to -1E

If you need standard-structure Servomotor connectors, consult your Yaskawa representative. To fabricate the cables, refer to this section.

To purchase cables with connectors, refer to the following section.

6.2 Servomotor Main Circuit Cables on page 6-5

If you need Servomotor connectors on both ends that are compliant with an IP67 protective structure and European Safety Standards, fabricate the cables by yourself or consult your Yaskawa representative. To fabricate the cables, refer to this section.

When you fabricate the cables, Yaskawa does not specify what wiring materials to use. Therefore, use appropriate wiring materials for your connectors and the electrical specifications.

6.4.1 Connector Structures

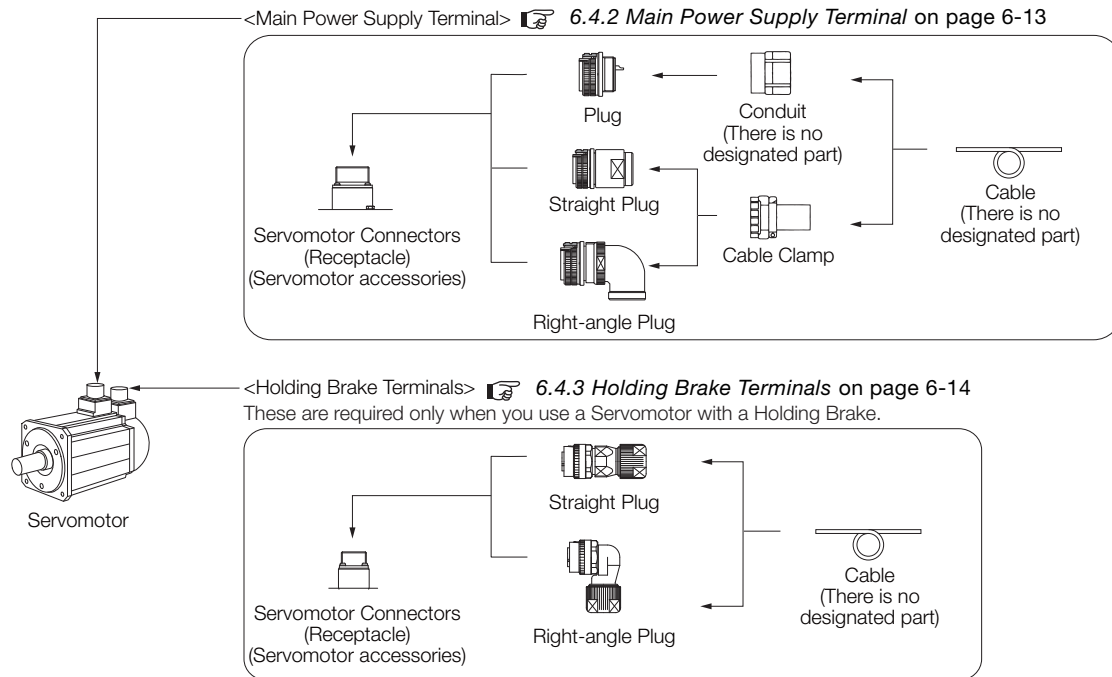

6.4.2 Main Power Supply Terminal

Servomotor Connector (Receptacle)

This connector is an accessory to the Servomotor.

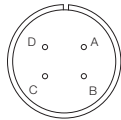
Servomotor Model	Capacity	Servomotor Connector Models	Connector Surface
SGM7G-09 SGM7G-13 SGM7G-20	850 W to 1.8 kW	CE05-2A18-10PD-D (MS Connector model: MS3102A18-10P)	
SGM7G-30 SGM7G-44	2.9 kW to 4.4 kW	CE05-2A22-22PD-D (MS Connector model: MS3102A22-22P)	
SGM7G-55 SGM7G-75 SGM7G-1A SGM7G-1E	5.5 kW to 15 kW	CE05-2A32-17PD-D (MS Connector model: MS3102A32-17P)	

Note: Servomotor Connectors (receptacle) are compatible with MS Connectors. To use a plug not specified by Yaskawa, select an appropriate plug with reference to the MS connector model number in the parentheses.

Cable-Side Connectors (Plug)

Cable-side connectors (plug) are available in the standard environment type and the type compliant with an IP67 protective structure and European Safety Standards and in the straight and right-angle shapes.

◆ Standard Environment Type: Cable-Side Connectors (Plug)

Servomotor Model	Capacity	Order Numbers		Manufacturer	
		Plug	Cable Clamp		
SGM7G-09 SGM7G-13 SGM7G-20	850 W to 1.8 kW	Straight	CE05-6A18-10SD-D-BSS	CE3057-10A-□-D	Fujikura Ltd.
			N/MS3106B18-10S	N/MS3057-10A	Japan Aviation Electronics Industry, Ltd.
		Right-angle	CE05-8A18-10SD-D-BAS	CE3057-10A-□-D	Fujikura Ltd.
			N/MS3108B18-10S	N/MS3057-10A	Japan Aviation Electronics Industry, Ltd.
SGM7G-30 SGM7G-44	2.9 kW to 4.4 kW	Straight	CE05-6A22-22SD-D-BSS	CE3057-12A-□-D	Fujikura Ltd.
			N/MS3106B22-22S	N/MS3057-12A	Japan Aviation Electronics Industry, Ltd.
		Right-angle	CE05-8A22-22SD-D-BAS	CE3057-12A-□-D	Fujikura Ltd.
			N/MS3108B22-22S	N/MS3057-12A	Japan Aviation Electronics Industry, Ltd.
SGM7G-55 SGM7G-75 SGM7G-1A SGM7G-1E	5.5 kW to 15 kW	Straight	CE05-6A32-17SD-D-BSS	CE3057-20A-□-D	Fujikura Ltd.
			N/MS3106B32-17S	N/MS3057-20A	Japan Aviation Electronics Industry, Ltd.
		Right-angle	CE05-8A32-17SD-D-BAS	CE3057-20A-□-D	Fujikura Ltd.
			N/MS3108B32-17S	N/MS3057-20A	Japan Aviation Electronics Industry, Ltd.

6.4.3 Holding Brake Terminals

◆ Type Compliant with an IP67 Protective Structure and European Safety Standards: Cable-Side Connectors (Plug)

Servomotor Model	Capacity	Order Numbers				Manufacturer
		Plug		Cable Clamp		
SGM7G-09 SGM7G-13 SGM7G-20	850 W to 1.8 kW	Single	CE05-6A18-10SD-D*	*		Fujikura Ltd.
		Straight	CE05-6A18-10SD-D-BSS	Order Numbers	Applicable Cable Diameter (Reference) [mm]	
				CE3057-10A-1-D	10.5 to 14.1	
				CE3057-10A-2-D	8.5 to 11.0	
Right-angle	CE05-8A18-10SD-D-BAS	CE3057-10A-3-D	6.5 to 8.7			
		* Using a single plug does not require a Cable Clamp. However, a conduit is required instead of a Cable Clamp. Yaskawa does not specify a specific conduit. For the conduit grounding, contact the manufacturer of the conduit.				
SGM7G-30 SGM7G-44	2.9 kW to 4.4 kW	Single	CE05-6A22-22SD-D*	*		
		Straight	CE05-6A22-22SD-D-BSS	Order Numbers	Applicable Cable Diameter (Reference) [mm]	
				CE3057-12A-1-D	12.5 to 16.0	
				CE3057-12A-2-D	9.5 to 13.0	
Right-angle	CE05-8A22-22SD-D-BAS	CE3057-12A-3-D	6.8 to 10.0			
		CE3057-12A-7-D	14.5 to 17.0			
SGM7G-55 SGM7G-75 SGM7G-1A SGM7G-1E	5.5 kW to 15 kW	Single	CE05-6A32-17SD-D*	*		
		Straight	CE05-6A32-17SD-D-BSS	Order Numbers	Applicable Cable Diameter (Reference) [mm]	
				CE3057-20A-1-D	22 to 23.8	
				CE3057-20A-2-D	24 to 26.6	
Right-angle	CE05-8A32-17SD-D-BAS	CE3057-20A-3-D	22 to 22.5			

* Using a single plug does not require a Cable Clamp. However, a conduit is required instead of a Cable Clamp. Yaskawa does not specify a specific conduit. For the conduit grounding, contact the manufacturer of the conduit.

6.4.3 Holding Brake Terminals

These are required only when you use a Servomotor with a Holding Brake.

Servomotor Connector (Receptacle)

This connector is an accessory to the Servomotor.

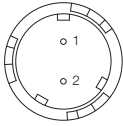
Servomotor Model	Capacity	Servomotor Connector Models	Connector Surface
SGM7G-09 SGM7G-13 SGM7G-20 SGM7G-30 SGM7G-44 SGM7G-55 SGM7G-75 SGM7G-1A SGM7G-1E	850 W to 15 kW	CM10-R2P-D	

Cable-Side Connectors (Plug)

Cable-side connectors (plug) are compliant with an IP67 protective structure and European Safety Standards. They are available in the straight and right-angle shapes.

Servomotor Model	Capacity	Order Numbers		Applicable Cable Diameter (Reference)	Manufacturer		
SGM7G-09	850 W to 15 kW	Straight	CM10-SP2S-S-D	4.0 mm to 6.0 mm	Fujikura Ltd.		
SGM7G-13			CM10-SP2S-M-D	6.0 mm to 9.0 mm			
SGM7G-20			CM10-SP2S-L-D	9.0 mm to 11.6 mm			
SGM7G-30		Right-angle	CM10-AP2S-S-D	4.0 mm to 6.0 mm			
SGM7G-44			CM10-AP2S-M-D	6.0 mm to 9.0 mm			
SGM7G-55			CM10-AP2S-L-D	9.0 mm to 11.6 mm			
SGM7G-75							
SGM7G-1A							
SGM7G-1E							

Information When consulting with your Yaskawa representative, refer to the following order number format.

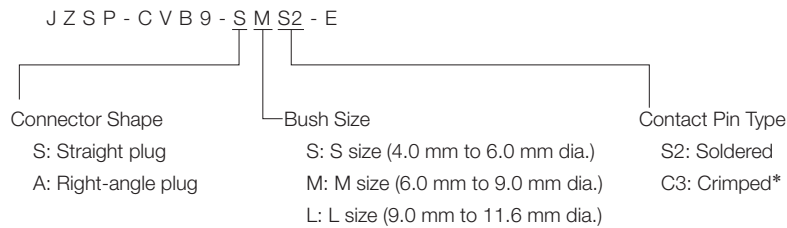

* Crimping Tool: A 357J-50448T from Fujikura Ltd. is required.

Information Other connector specifications

Item	Specifications
User Instructions	<ul style="list-style-type: none"> • Straight Plug (CM10-SP2S-□-D): TC-583 • Right-Angle plug (CM10-AP2S-□-D): TC-573
Contact Models	<ul style="list-style-type: none"> ■ Loose Contacts (100 per bag) • Crimped Contacts: CM10-#22SC(C3)-100 Wire size: AWG16 to AWG20 Outer diameter of insulating sheath: 1.87 mm to 2.45 mm Manual Crimping Tool: 357J-50448T • Soldered Contacts: CM10-#22SC(S2)-100 Wire size: AWG16 max. ■ Reeled Contacts (4,000 per reel) • Crimped Contacts: CM10-#22SC(C3)-4000 Wire size: AWG16 to AWG20 Outer diameter of insulating sheath: 1.87 mm to 2.45 mm Semi-automatic Crimping Tool: AP-A50541T (Set) AP-A50541T-1 (Applicator) <p>Note: The Semi-automatic Tool Set includes the press and Applicator (crimper).</p>

6.4.4 Connector External Dimensions

Main Power Supply Terminal

◆ Straight Plug: CE05-6A□□-□□SD-D-BSS (from Fujikura Ltd.)

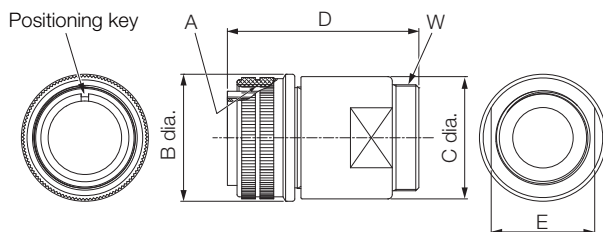

Unit: mm

Model	Shell Size	Joint Thread A	Joint Nut Outer Diameter B $+0_{-0.38}$ Dia.	Max. Diameter C ± 0.8 Dia.	Total Length D Max.	Spanner Fitting Width Across Flat E	Cable Clamp Mounting Thread W
CE05-6A18-10SD-D-BSS	18	1-1/8-18UNEF-2B	34.13	32.1	57	26.7	1-20UNEF-2A
CE05-6A22-22SD-D-BSS	22	1-3/8-18UNEF-2B	40.48	38.3	61	32.4	1-3/16-18UNEF-2A
CE05-6A32-17SD-D-BSS	32	2 18UNS-2B	56.33	54.2	79	47.3	1-3/4-18UNS-2A

◆ Straight Plug: N/MS3106B□□-□□S (from Japan Aviation Electronics Industry, Ltd.)

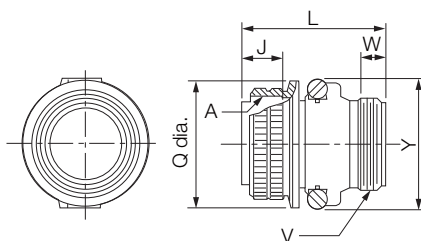

Unit: mm

Model	Shell Size	Joint Thread A	Length of Joint J ± 0.12	Total Length L Max.	Joint Nut Outer Diameter Q $+0_{-0.38}$ Dia.	Cable Clamp Mounting Thread V	Effective Thread Length W Min.	Maximum Width Y Max.
N/MS3106B18-10S	18	1-1/8-18UNEF	18.26	52.37	34.13	1-20UNEF	9.53	42
N/MS3106B22-22S	22	1-3/8-18UNEF	18.26	55.57	40.48	1-3/16-18UNEF	9.53	50
N/MS3106B32-17S	32	2-18UNS	18.26	61.92	56.33	1-3/4-18UNS	11.13	66

◆ Right-Angle Plug: CE05-8A□□-□□SD-D-BAS (from Fujikura Ltd.)

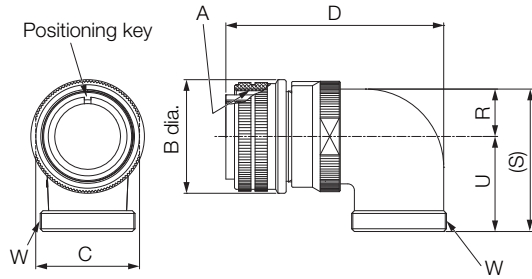

Unit: mm

Model	Shell Size	Joint Thread A	Joint Nut Outer Diameter B ⁺⁰ _{-0.38} Dia.	Spanner Fitting Width Across Flat C	Total Length D Max.	Cable Clamp Mounting Thread W	R ± 0.7	U ± 0.7	(S) ± 1
CE05-8A18-10SD-D-BAS	18	1-1/8-18UNEF-2B	34.13	30.0	69.5	1-20UNEF-2A	13.2	30.2	43.4
CE05-8A22-22SD-D-BAS	22	1-3/8-18UNEF-2B	40.48	36.2	75.5	1-3/16-18UNEF-2A	16.3	33.3	49.6
CE05-8A32-17SD-D-BAS	32	2-18UNS-2B	56.33	52.8	93.5	1-3/4-18UNS-2A	24.6	44.5	69.1

◆ Right-Angle Plug: N/MS3108B□□-□□S (from Japan Aviation Electronics Industry, Ltd.)

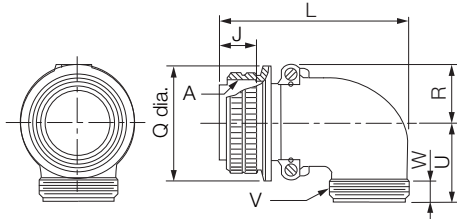

Unit: mm

Model	Shell Size	Joint Thread A	Length of Joint J ± 0.12	Total Length L Max.	Joint Nut Outer Diameter Q ⁺⁰ _{-0.38} Dia.	R ± 0.5	U ± 0.5	Cable Clamp Mounting Thread V	Effective Thread Length W Min.
N/MS3108B18-10S	18	1-1/8-18UNEF	18.26	68.27	34.13	20.5	30.2	1-20UNEF	9.53
N/MS3108B22-22S	22	1-3/8-18UNEF	18.26	76.98	40.48	24.1	33.3	1-3/16-18UNEF	9.53
N/MS3108B32-17S	32	2-18UNS	18.26	95.25	56.33	32.8	44.4	1-3/4-18UNS	11.13

◆ Cable Clamp: CE3057-□□A-□-D (from Fujikura Ltd.)

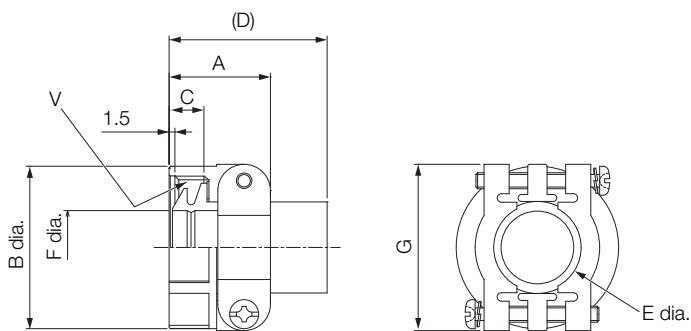

Unit: mm

Model	Applicable Connector Shell Size	Total Length A ± 0.7	Outer Diameter B Dia.	Effective Thread Length C	(D)	Bushing Outer Diameter E Dia.	Bushing Inner Diameter F Dia.	G ± 0.7	Mounting Thread V	Attached Bushing	Applicable Cable Diameter (Reference)
CE3057-10A-1-D	18	23.83	30.1	10.31	(41.3)	15.8	14.1	31.7	1-20UNEF-2B	CE3420-10-1	10.5 to 14.1
CE3057-10A-2-D							11			CE3420-10-2	8.5 to 11.0
CE3057-10A-3-D							8.7			CE3420-10-3	6.5 to 8.7
CE3057-12A-1-D	22	23.83	35	10.31	(41.3)	19.0	16	37.3	1-3/16-18UNEF-2B	CE3420-12-1	12.5 to 16.0
CE3057-12A-2-D							13			CE3420-12-2	9.5 to 13.0
CE3057-12A-3-D							10			CE3420-12-3	6.8 to 10.0
CE3057-12A-7-D							17			CE3420-12-7	14.5 to 17.0
CE3057-20A-1-D	32	27.79	51.6	11.91	(43.0)	32.0	23.8	51.6	1-3/4-18UNS-2B	CE3420-20-1	22.0 to 23.8
CE3057-20A-2-D							26.6			CE3420-20-2	24.0 to 26.6
CE3057-20A-3-D							22.5			CE3420-20-3	21.0 to 22.5

◆ Cable Clamp: N/MS3057-□□A (from Japan Aviation Electronics Industry, Ltd.)

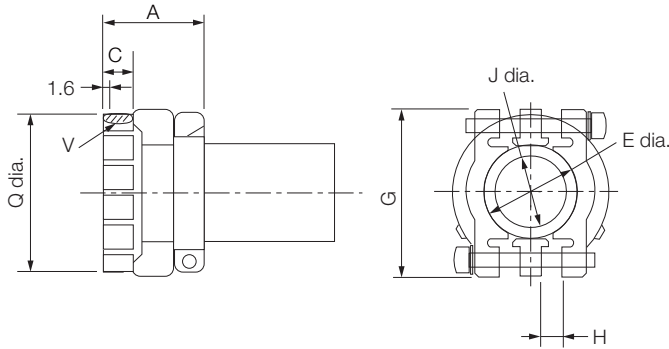

Unit: mm

Model	Applicable Connector Shell Size	Total Length A ± 0.7	Effective Thread Length C	Cable Clamp Inner Diameter E Dia.	G ± 0.7	Slide Range H	Bushing Inner Diameter J Dia.	Mounting Thread V	Outer Diameter Q ± 0.7 Dia.	Attached Bushing
N/MS3057-10A	18	23.8	10.3	15.9	31.7	3.2	14.3	1-20UNEF	30.1	AN3420-10
N/MS3057-12A	22	23.8	10.3	19	37.3	4	15.9	1-3/16-18UNEF	35.0	AN3420-12
N/MS3057-20A	32	27.8	11.9	31.7	51.6	6.3	23.8	1-3/4-18UNS	51.6	AN3420-20

Note: A rubber bushing is included.

Holding Brake Terminals

◆ Straight Plug: CM10-SP2S-□-D

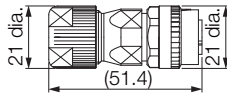

Unit: mm

◆ Right-Angle Plug: CM10-AP2S-□-D

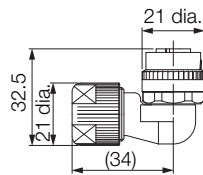

Unit: mm

6.5 Encoder Cables of 20 m or Less

6.5.1 Encoder Cables for Incremental Encoders or Batteryless Absolute Encoders

Selection Table

Servomotor Model	Connector Specifications	Length (L)	Order Number* ¹	
			Standard Cable	Flexible Cable* ^{2, *3}
All SGM7G models	Straight	3 m, 5 m, 10 m, 15 m, and 20 m	JZSP-CVP01-□□-E	JZSP-CVP11-□□-E
	Right-angle* ⁴		JZSP-CVP02-□□-E	JZSP-CVP12-□□-E

*1. Replace the boxes (□□) in the order number with the cable length (03, 05, 10, 15, or 20).

*2. Use Flexible Cables for moving parts of machines, such as robots.

*3. The recommended bending radius (R) is 46 mm or larger.

*4. The lead installation direction is away from the load. Consult your Yaskawa representative for other lead installation directions.

Appearance

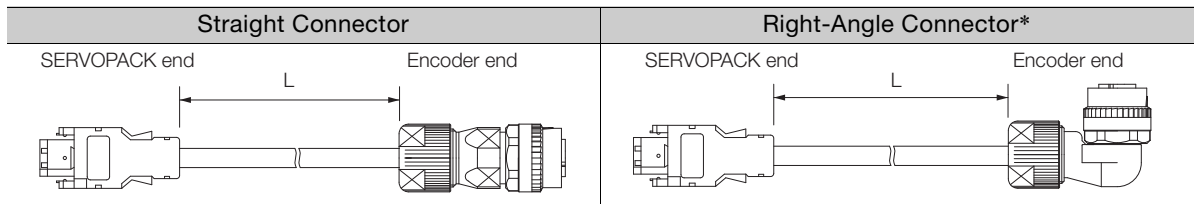

* The lead installation direction is away from the load. Consult your Yaskawa representative for other lead installation directions.

Wiring Specifications

Standard Cable				Flexible Cable			
SERVOPACK end		Encoder (motor) end		SERVOPACK end		Encoder (motor) end	
Pin	Signal	Pin	Wire Color	Pin	Signal	Pin	Wire Color
6	/PS	2	Light blue/white	6	/PS	2	Black/pink
5	PS	1	Light blue	5	PS	1	Red/pink
4	BAT(-)	5	Orange/white	4	BAT(-)	5	Black/light blue
3	BAT(+)	6	Orange	3	BAT(+)	6	Red/light blue
2	PG 0 V	9	Black	2	PG 0 V	9	Light green
1	PG 5 V	4	Red	1	PG 5 V	4	Orange
Shell	FG	10	FG	Shell	FG	10	FG

6.5.2 Encoder Cables for Absolute Encoders

These cables are equipped with a Battery Case. (A Battery is included.)

Note: If a battery is connected to the host controller, the Battery Case is not required. Use an Encoder Cable for Incremental Encoders or Batteryless Absolute Encoders.

NOTICE

- Install a battery at either the host controller or on the Encoder Cable.
If you install batteries both at the host controller and on the Encoder Cable at the same time, you will create a loop circuit between the batteries, resulting in a risk of damage or burning.

Selection Table

Servomotor Model	Connector Specifications	Length (L)	Order Number ^{*1}	
			Standard Cable	Flexible Cable ^{*2, *3}
All SGM7G models	Straight	3 m, 5 m, 10 m, 15 m, and 20 m	JZSP-CVP06-□□-E	JZSP-CVP26-□□-E
	Right-angle ^{*4}		JZSP-CVP07-□□-E	JZSP-CVP27-□□-E

*1. Replace the boxes (□□) in the order number with the cable length (03, 05, 10, 15, or 20).

*2. Use Flexible Cables for moving parts of machines, such as robots.

*3. The recommended bending radius (R) is 46 mm or larger.

*4. The lead installation direction is away from the load. Consult your Yaskawa representative for other lead installation directions.

Appearance

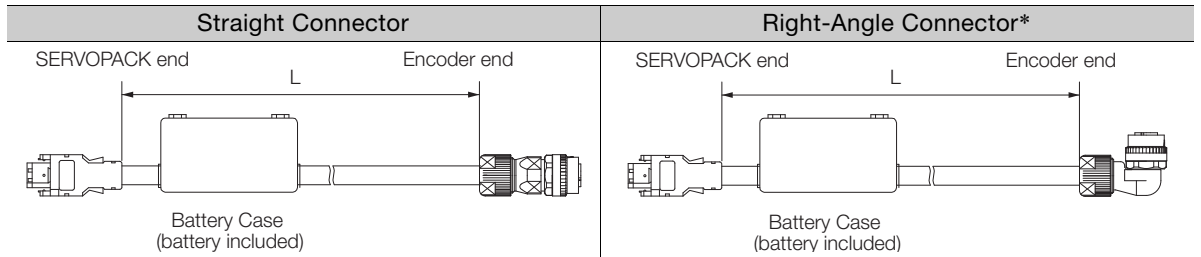

* The lead installation direction is away from the load. Consult your Yaskawa representative for other lead installation directions.

Wiring Specifications

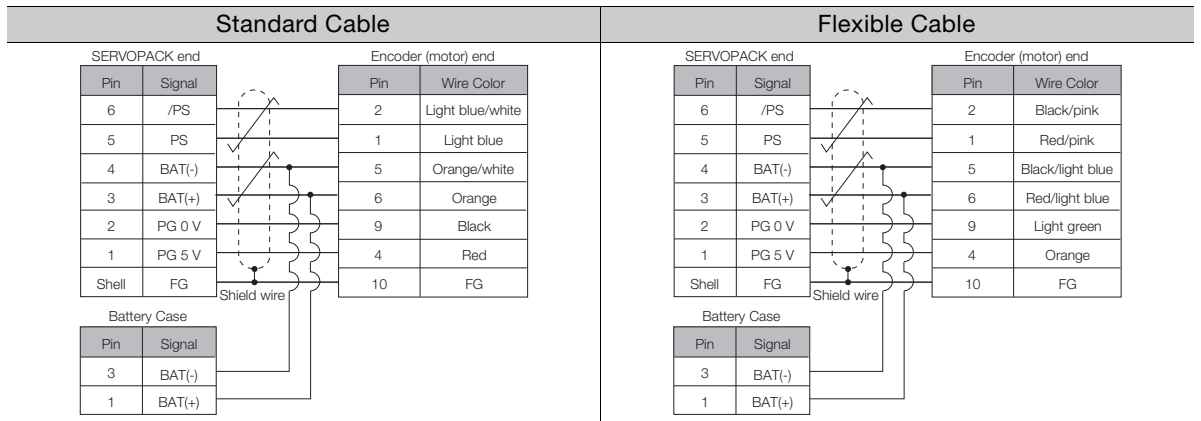

6.6 Relay Encoder Cables of 30 m to 50 m

If the Encoder Cable length exceeds 20 m, be sure to also use a Motor-End Relay Encoder Cable and a SERVOPACK-End Relay Encoder Cable.

If you use a motor with an absolute encoder and a battery is not mounted to the host controller, also obtain a Relay Encoder Cable with a Battery Case in addition to the above two Cables.

NOTICE

- Install a battery at either the host controller or on the Encoder Cable.
If you install batteries both at the host controller and on the Encoder Cable at the same time, you will create a loop circuit between the batteries, resulting in a risk of damage or burning.

6.6.1 Motor-End Relay Encoder Cables

Selection Table

Connector Specifications	Specification	Length (L)	Order Number
Straight Connector	Used for all types of encoders.	0.3 m	JZSP-CVP01-E
Right-Angle Connector*			JZSP-CVP02-E

* The lead installation direction is away from the load. Consult your Yaskawa representative for other lead installation directions.

Appearance

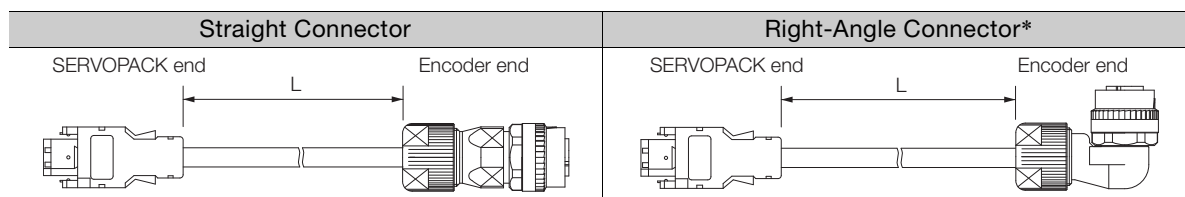

* The lead installation direction is away from the load. Consult your Yaskawa representative for other lead installation directions.

Wiring Specifications

SERVOPACK end		Encoder (motor) end	
Pin	Signal	Pin	Wire Color
6	/PS	2	Light blue/white
5	PS	1	Light blue
4	BAT(-)	5	Orange/white
3	BAT(+)	6	Orange
2	PG 0 V	9	Black
1	PG 5 V	4	Red
Shell	FG	10	FG

Note: BAT(+) and BAT(-) are wired for an absolute encoder.

6.6.2 SERVOPACK-End Relay Encoder Cables

Selection Table

Specification	Length (L)	Order Number*
Used for all types of encoders.	30 m, 40 m, and 50 m	JZSP-UCMP00-□□-E

* Replace the boxes (□□) in the order number with the cable length (30, 40, or 50).

Appearance

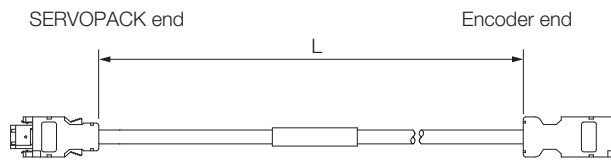

Wiring Specifications

SERVOPACK end		Encoder (motor) end	
Pin	Signal	Pin	Wire Color
6	/PS	6	Light blue/white
5	PS	5	Light blue
4	BAT(-)	4	Orange/white
3	BAT(+)	3	Orange
2	PG 0 V	2	Black
1	PG 5 V	1	Red
Shell	FG	Shell	FG

Shield wire

6.6.3 Relay Encoder Cables with Battery Cases

Note: This Cable is not required if you use a Servomotor with an Incremental Encoder, use a Servomotor with a Batteryless Absolute Encoder, or connect a battery to the host controller.

Selection Table

Length (L)	Order Number
0.3 m	JZSP-CSP12-E

Appearance

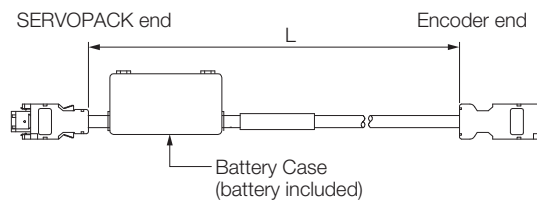

Wiring Specifications

SERVOPACK end		Encoder (motor) end	
Pin	Signal	Pin	Wire Color
6	/PS	6	Light blue/white
5	PS	5	Light blue
4	BAT(-)	4	Orange/white
3	BAT(+)	3	Orange
2	PG 0 V	2	Black
1	PG 5 V	1	Red
Shell	FG	Shell	FG

Shield wire

Battery Case	
Pin	Signal
3	BAT(-)
1	BAT(+)

6.7 User-Assembled Wiring Materials for Encoder Cables

6.7.1 Precautions When Using Encoder Cables with a Wiring Length of 30 m to 50 m

When using Encoder Cables with a wiring length of 30 m to 50 m, it is necessary to fabricate two different types of cables.

Cables to be Fabricated	Connectors and Wire Materials Required for Fabrication	Reference Page	Remarks
Motor-End Relay Encoder Cable	SERVOPACK Connector	6.7.2 <i>SERVOPACK Connector Kits</i> on page 6-24	This cable should be 0.3 m or less.
	Servomotor Connector	6.7.3 <i>Encoder Connector Kits</i> on page 6-25	
	Encoder Cable (20 m or less)	6.7.4 <i>Cables without Connectors</i> on page 6-26	
SERVOPACK-End Relay Encoder Cable	SERVOPACK Connector	6.7.2 <i>SERVOPACK Connector Kits</i> on page 6-24	This cable should be 50 m or less.
	Cable Relay Connector	6.7.3 <i>Encoder Connector Kits</i> on page 6-25	
	Relay Encoder Cable (30 m to 50 m)	6.7.4 <i>Cables without Connectors</i> on page 6-26	

Refer to the following section for details on the connection of the Relay Encoder Cable.

 6.1 *Cable Configurations* on page 6-3

6.7.2 SERVOPACK Connector Kits

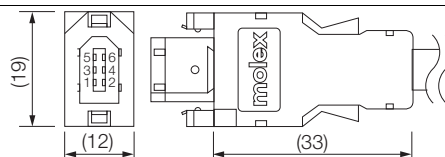
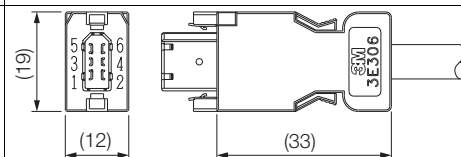
Type	Standard Connector Kit	Compatible Connector Kit
Inquires	Yaskawa representative	3M Japan Limited
Manufacturer	Molex Incorporated	
Order Number	JZSP-CMP9-1-E	
Specifications	55100-0670 (soldered) Product specifications: PS-54280	Receptacle: 3E206-0100 KV (soldered) Shell Kit: 3E306-3200-008 Product specifications: JNPS-1042 and JNPS-1043
External Dimensions [mm]		

Note: Cables are not included. Purchase them separately.

6.7.3 Encoder Connector Kits

IP67-Structure Servomotor Connectors

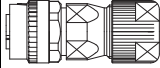
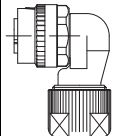
Type	Order Number	Specification	External Dimensions	Manufacturer
Straight Plug	JZSP-CVP9-1-E	<ul style="list-style-type: none"> Plug: CM10-SP10S-M-D Contacts: Crimped* CM10-#22SC(C4)-100 Applicable cable diameter: 6.0 mm to 9.0 mm 	 Accessories: Contacts	Fujikura Ltd.
	JZSP-CVP9-3-E	<ul style="list-style-type: none"> Plug: CM10-SP10S-M-D Contacts: Soldered CM10-#22SC(S1)-100 Applicable cable diameter: 6.0 mm to 9.0 mm 		
Right-Angle Plug	JZSP-CVP9-2-E	<ul style="list-style-type: none"> Plug: CM10-AP10S-M-D Contacts: Crimped* CM10-#22SC(C4)-100 Applicable cable diameter: 6.0 mm to 9.0 mm 	 Accessories: Contacts	
	JZSP-CVP9-4-E	<ul style="list-style-type: none"> Plug: CM10-AP10S-M-D Contacts: Soldered CM10-#22SC(S1)-100 Applicable cable diameter: 6.0 mm to 9.0 mm 		

* A Crimping Tool is required. The following Crimping Tool is applicable to the Cables provided by Yaskawa. When using other wire sizes, contact the connector manufacturer for crimping tools.
 Crimping Tool: 357J-52667T

Cable Relay Connectors

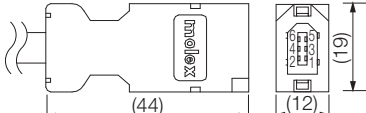
Order Number	JZSP-CMP9-2-E
Manufacturer	Molex Incorporated
Components	54280-0609 (soldered)
Product Specifications	PS-54280
External Dimensions [mm]	

6.7.4 Cables without Connectors

Encoder Cables of 20 m or Less

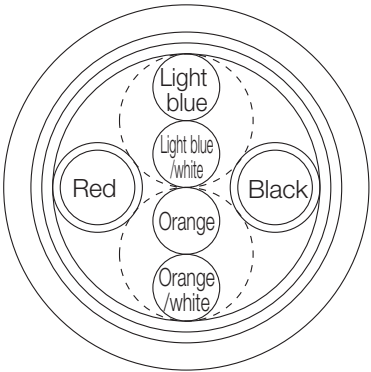
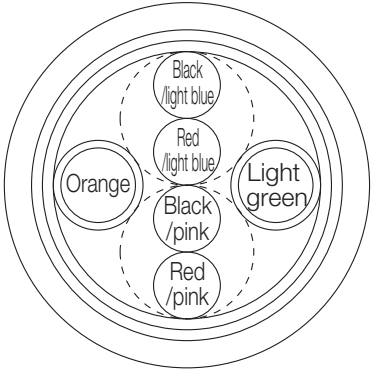
Item	Standard Cable	Flexible Cable
Order Number*	JZSP-CMP09-□□-E (maximum length: 20 m)	JZSP-CSP39-□□-E (maximum length: 20 m)
Specifications	UL20276 (rated temperature: 80°C) AWG22 × 2C + AWG24 × 2P	UL20276 (rated temperature: 80°C) AWG22 × 2C + AWG24 × 2P
	AWG22 (0.33 mm ²) Outer diameter of insulating sheath: 1.15 mm	AWG22 (0.33 mm ²) Outer diameter of insulating sheath: 1.35 mm
	AWG24 (0.20 mm ²) Outer diameter of insulating sheath: 1.09 mm	AWG24 (0.20 mm ²) Outer diameter of insulating sheath: 1.21 mm
Finished Diameter	6.5 mm	6.8 mm
Internal Structure and Lead Colors		

* Replace the boxes (□□) in the order number with the cable length (05, 10, 15, or 20).

Relay Encoder Cable of 30 m to 50 m

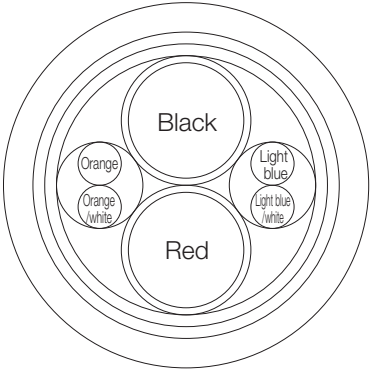
Item	Standard Cable
Order Number*	JZSP-CMP19-□□-E (maximum length: 50 m)
Specifications	UL20276 (rated temperature: 80°C) AWG16 × 2C + AWG26 × 2P
	AWG16 (1.31 mm ²) Outer diameter of insulating sheath: 2.0 mm
	AWG26 (0.13 mm ²) Outer diameter of insulating sheath: 0.91 mm
Finished Diameter	6.8 mm
Internal Structure and Lead Colors	

* Replace the boxes (□□) in the order number with the cable length (30, 40, or 50).

6.8 Wiring Precautions

The wiring precautions are the same as for SGM7M Rotary Servomotors. Refer to the following section.

 2.5 *Wiring Precautions* on page 2-9

Cables and User-Assembled Wiring Materials for SGMMV Rotary Servomotors



7.1	Cable Configurations	7-2
7.2	Servomotor Main Circuit Cables	7-3
7.2.1	Servomotor Main Circuit Cables for Servomotors without Holding Brakes	7-3
7.2.2	Servomotor Main Circuit Cables for Servomotors with Holding Brakes	7-4
7.3	Encoder Cables of 20 m or Less	7-5
7.3.1	Encoder Cables for Incremental Encoders	7-5
7.3.2	Encoder Cables for Absolute Encoders	7-6
7.4	Relay Encoder Cable of 30 m to 50 m	7-7
7.4.1	Relay Encoder Cables	7-7
7.4.2	Relay Encoder Cables with Battery Cases	7-8
7.5	User-Assembled Wiring Materials for Encoder Cables	7-9
7.5.1	Connector Kits	7-9
7.5.2	Cables without Connectors	7-10
7.6	Wiring Precautions	7-11

7.1 Cable Configurations

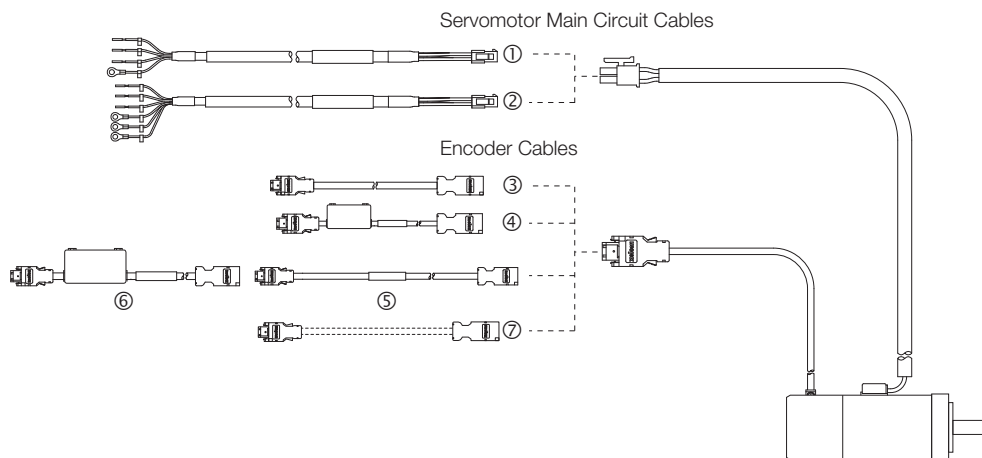

No.	Cable Type	Reference	
①	Servomotor Main Circuit Cables for Servomotors without Holding Brakes	page 7-3	
②	Servomotor Main Circuit Cables for Servomotors with Holding Brakes	page 7-4	
③	Encoder Cables of 20 m or less for Incremental Encoders	page 7-5	
④	Encoder Cables of 20 m or less with Battery Cases for Absolute Encoders	page 7-6	
⑤	Relay Encoder Cables of 30 m to 50 m	page 7-7	
⑥	Relay Encoder Cables with a Battery Case		
⑦	User-Assembled Wiring Materials for Encoder Cables*	Connector Kits	page 7-9
		Cables without Connectors	page 7-10

* When you fabricate the Encoder Cable, always connect the shield wire from the Encoder Cable to the connector (shell). There is a risk of failure or malfunction.

7.2

Servomotor Main Circuit Cables

7.2.1

Servomotor Main Circuit Cables for Servomotors without Holding Brakes

Selection Table

Servomotor Model	Length (L)	Order Number ^{*1}	
		Standard Cable	Flexible Cable ^{*2, *3}
SGMMV-A1 to -A3 10 W to 30 W	3 m, 5 m, 10 m, 15 m, 20 m, 30 m, 40 m, and 50 m	JZSP-CF2M00-□□-E	JZSP-CF2M20-□□-E

*1. Replace the boxes (□□) in the order number with the cable length (03, 05, 10, 15, 20, 30, 40, or 50).

*2. Use Flexible Cables for moving parts of machines, such as robots.

*3. The recommended bending radius (R) is 90 mm or larger.

Note: If the length of the Servomotor Main Circuit Cable exceeds 20 m, the intermittent duty zone in the torque-motor speed characteristics will become smaller because the voltage drop increases.

Appearance

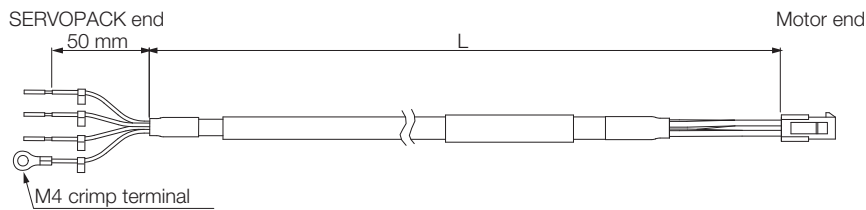

Wiring Specifications

SERVOPACK Leads		Servomotor Connector	
Wire Color	Signal	Signal	Pin
Red	Phase U	Phase U	1
White	Phase V	Phase V	2
Blue	Phase W	Phase W	3
Green/yellow	FG	FG	4

7.2.2 Servomotor Main Circuit Cables for Servomotors with Holding Brakes

Selection Table

Servomotor Model	Length (L)	Order Number*1	
		Standard Cable	Flexible Cable*2, *3
SGMMV-A1 to -A3 10 W to 30 W	3 m, 5 m, 10 m, 15 m, 20 m, 30 m, 40 m, and 50 m	JZSP-CF2M03-□□-E	JZSP-CF2M23-□□-E

*1. Replace the boxes (□□) in the order number with the cable length (03, 05, 10, 15, 20, 30, 40, or 50).

*2. Use Flexible Cables for moving parts of machines, such as robots.

*3. The recommended bending radius (R) is 90 mm or larger.

Note: If the length of the Servomotor Main Circuit Cable exceeds 20 m, the intermittent duty zone in the torque-speed characteristics will become smaller because the voltage drop increases.

Appearance

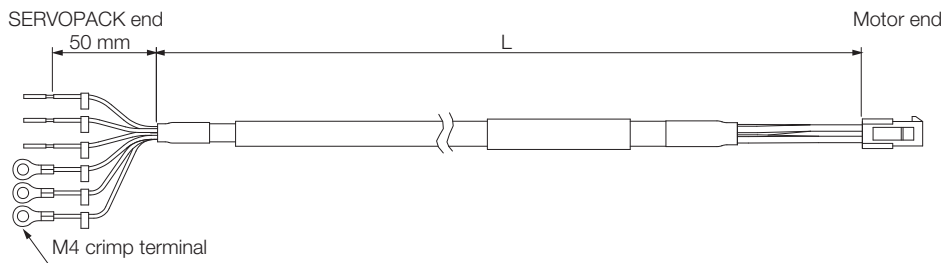

Wiring Specifications

SERVOPACK Leads		Servomotor Connector	
Wire Color	Signal	Signal	Pin
Red	Phase U	Phase U	1
White	Phase V	Phase V	2
Blue	Phase W	Phase W	3
Green/yellow	FG	FG	4
Black	Brake	Brake	5
Black	Brake	Brake	6

Note: There is no polarity for the connection to the holding brake.

7.3 Encoder Cables of 20 m or Less

7.3.1 Encoder Cables for Incremental Encoders

Selection Table

Servomotor Model	Length (L)	Order Number* ¹	
		Standard Cable	Flexible Cable* ^{2, *3}
SGMMV-A1 to -A3 10 W to 30 W	3 m, 5 m, 10 m, 15 m, and 20 m	JZSP-CMP00-□□-E	JZSP-CMP10-□□-E

- *1. Replace the boxes (□□) in the order number with the cable length (03, 05, 10, 15, or 20).
- *2. Use Flexible Cables for moving parts of machines, such as robots.
- *3. The recommended bending radius (R) is 46 mm or larger.

Appearance

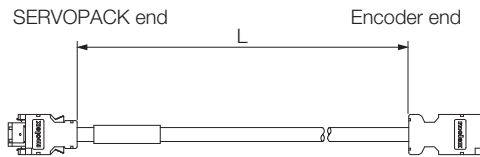

Wiring Specifications

Standard Cable					Flexible Cable				
SERVOPACK end		Shield wire	Encoder (motor) end		SERVOPACK end		Shield wire	Encoder (motor) end	
Pin	Signal		Pin	Wire Color	Pin	Signal		Pin	Wire Color
6	/PS		6	Light blue/white	6	/PS		6	Black/light blue
5	PS		5	Light blue	5	PS		5	Red/light blue
4	BAT(-)		4	Orange/white	4	BAT(-)		4	Black/pink
3	BAT(+)		3	Orange	3	BAT(+)		3	Red/pink
2	PG 0V		2	Black	2	PG 0V		2	Light green
1	PG 5V		1	Red	1	PG 5V		1	Orange
Shell	FG		Shell	FG	Shell	FG		Shell	FG

7.3.2 Encoder Cables for Absolute Encoders

These cables are equipped with a Battery Case. (A Battery is included.)

Note: If a battery is connected to the host controller, the Battery Case is not required. If so, use a cable for incremental encoders.

NOTICE

- Install a battery at either the host controller or on the Encoder Cable.
If you install batteries both at the host controller and on the Encoder Cable at the same time, you will create a loop circuit between the batteries, resulting in a risk of damage or burning.

Selection Table

Servomotor Model	Length (L)	Order Number*1	
		Standard Cable	Flexible Cable*2, *3
SGMMV-A1 to -A3 10 W to 30 W	3 m, 5 m, 10 m, 15 m, and 20 m	JZSP-CSP19-□□-E	JZSP-CSP29-□□-E

*1. Replace the boxes (□□) in the order number with the cable length (03, 05, 10, 15, or 20).

*2. Use Flexible Cables for moving parts of machines, such as robots.

*3. The recommended bending radius (R) is 46 mm or larger.

Appearance

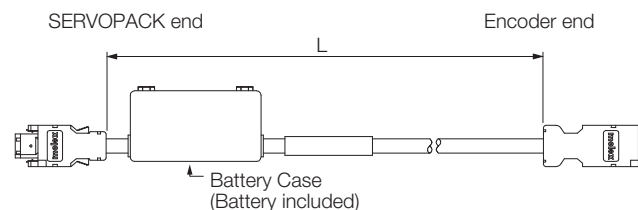

Wiring Specifications

Standard Cable				Flexible Cable			
SERVOPACK end		Encoder (motor) end		SERVOPACK end		Encoder (motor) end	
Pin	Signal	Pin	Wire Color	Pin	Signal	Pin	Wire Color
6	/PS	6	Light blue/white	6	/PS	6	Black/pink
5	PS	5	Light blue	5	PS	5	Red/pink
4	BAT(-)	4	Orange/white	4	BAT(-)	4	Black/light blue
3	BAT(+)	3	Orange	3	BAT(+)	3	Red/light blue
2	PG 0 V	2	Black	2	PG 0 V	2	Light green
1	PG 5 V	1	Red	1	PG 5 V	1	Orange
Shell	FG	Shell	FG	Shell	FG	Shell	FG
Battery Case		Shield wire		Battery Case		Shield wire	
Pin	Signal			Pin	Signal		
3	BAT(-)			3	BAT(-)		
1	BAT(+)			1	BAT(+)		

7.4 Relay Encoder Cable of 30 m to 50 m

If you use a motor with an absolute encoder and a battery is not mounted to the host controller, also obtain a Relay Encoder Cable with a Battery Case in addition to the normal Relay Encoder Cable.

NOTICE

- Install a battery at either the host controller or on the Encoder Cable.
If you install batteries both at the host controller and on the Encoder Cable at the same time, you will create a loop circuit between the batteries, resulting in a risk of damage or burning.

7.4.1 Relay Encoder Cables

Selection Table

Specifications	Length (L)	Order Number*
For incremental/absolute encoder	30 m, 40 m, and 50 m	JZSP-UCMP00-□□-E

* Replace the boxes (□□) in the order number with the cable length (30, 40, or 50).

Appearance

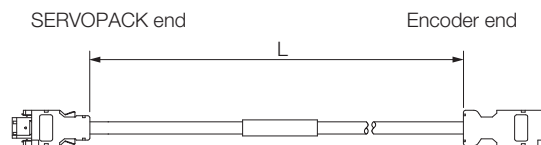

Wiring Specifications

SERVOPACK end		Encoder (motor) end	
Pin	Signal	Pin	Wire Color
6	/PS	6	Light blue/white
5	PS	5	Light blue
4	BAT (-)	4	Orange/white
3	BAT (+)	3	Orange
2	PG 0 V	2	Black
1	PG 5 V	1	Red
Shell	FG	Shell	FG

Shield wire

7.4.2 Relay Encoder Cables with Battery Cases

Note: This Cable is not required if you use a Servomotor with an Incremental Encoder or connect a battery to the host controller.

Selection Table

Length (L)	Order Number
0.3 m	JZSP-CSP12-E

Appearance

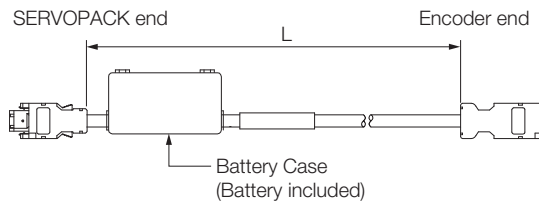

Wiring Specifications

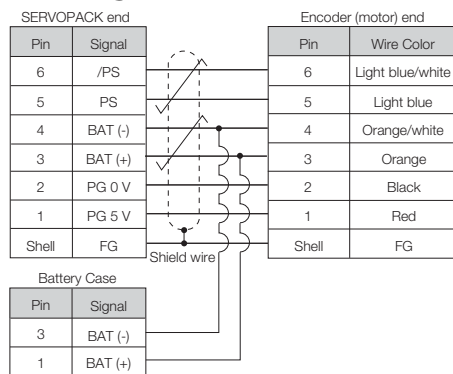

7.5

User-Assembled Wiring Materials for Encoder Cables

7.5.1 Connector Kits

SERVOPACK Connector Kits

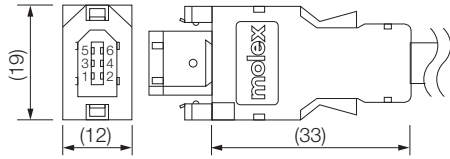
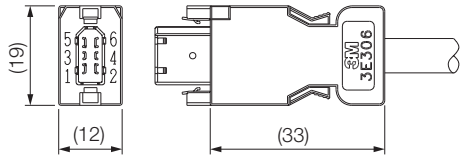
Type	Standard Cable	Compatible Connector Kit
Inquiries	Yaskawa representative	3M Japan Limited
Manufacturer	Molex Incorporated	
Order Number	JZSP-CMP9-1-E	
Specifications	55100-0670 (soldered) Product specifications: PS-54280	Receptacle: 3E206-0100 KV (soldered) Shell Kit: 3E306-3200-008 Product specifications: JNPS-1042 and JNPS-1043
External Dimensions [mm]		

Note: Cables are not included. Purchase them separately.

Encoder Connector Kits

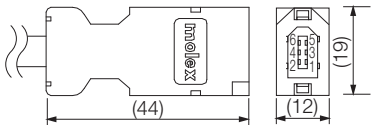
Order Number	JZSP-CMP9-2-E
Manufacturer	Molex Incorporated
Components	54280-0609 (soldered)
Product Specifications	PS-54280
External Dimensions [mm]	

7.5.2 Cables without Connectors

Encoder Cables of 20 m or Less

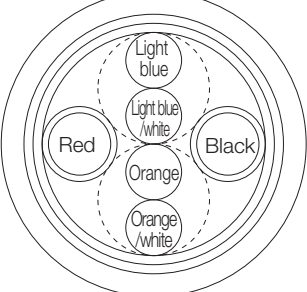
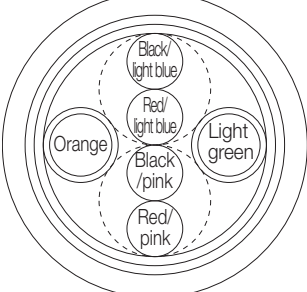
Item	Standard Cable	Flexible Cable
Order Number*	JZSP-CMP09-□□-E (maximum length: 20 m)	JZSP-CSP39-□□-E (maximum length: 20 m)
Specifications	UL20276 (rated temperature: 80°C) AWG22 × 2C + AWG24 × 2P	UL20276 (rated temperature: 80°C) AWG22 × 2C + AWG24 × 2P
	AWG22 (0.33 mm ²) Outer diameter of insulating sheath: 1.15 mm	AWG22 (0.33 mm ²) Outer diameter of insulating sheath: 1.35 mm
	AWG24 (0.20 mm ²) Outer diameter of insulating sheath: 1.09 mm	AWG24 (0.20 mm ²) Outer diameter of insulating sheath: 1.21 mm
Finished Diameter	6.5 mm	6.8 mm
Internal Structure and Lead Colors		

* Replace the boxes (□□) in the order number with the cable length (05, 10, 15, or 20).

Relay Encoder Cable of 30 m to 50 m

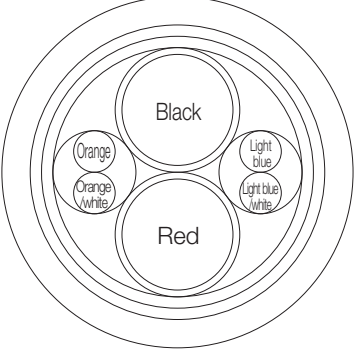
Item	Standard Cable
Order Number*	JZSP-CMP19-□□-E (maximum length: 50 m)
Specifications	UL20276 (rated temperature: 80°C) AWG16 × 2C + AWG26 × 2P
	AWG16 (1.31 mm ²) Outer diameter of insulating sheath: 2.0 mm
	AWG26 (0.13 mm ²) Outer diameter of insulating sheath: 0.91 mm
Finished Diameter	6.8 mm
Internal Structure and Lead Colors	

* Replace the boxes (□□) in the order number with the cable length (30, 40, or 50).

7.6 Wiring Precautions

The wiring precautions are the same as for SGM7M Rotary Servomotors. Refer to the following section.

 2.5 *Wiring Precautions* on page 2-9

Cables and User-Assembled Wiring Materials for Direct Drive Servomotors

8

8.1	Cable Configurations	8-3
8.1.1	SGM7D Servomotors	8-3
8.1.2	SGM7E Motors and SGM7F-□□A to -□□D Motors	8-4
8.1.3	SGM7F-□□M and -□□N Motors and SGMCS Motors	8-5
8.1.4	SGM7F Servomotors	8-6
8.2	Servomotor Main Circuit Cables	8-7
8.2.1	SGM7D Servomotor Main Circuit Cables	8-7
8.2.2	Main Circuit Cables for SGM7E and SGM7F-□□A to -□□D Motors	8-8
8.2.3	Main Circuit Cables for SGM7F-□□M, -□□N, and SGMCS Motors	8-9
8.2.4	SGM7F Servomotor Main Circuit Cables	8-11
8.3	User-Assembled Wiring Materials for Servomotor Main Circuit Cables . .	8-12
8.3.1	Servomotor Connector Kits	8-12
8.3.2	Cables without Connectors	8-16
8.4	Encoder Cables of 20 m or Less	8-18
8.4.1	SGM7D Encoder Cables	8-18
8.4.2	Encoder Cables for SGM7E and SGM7F Servomotors	8-20
8.4.3	SGM7F Encoder Cables	8-24
8.4.4	SGMCS Encoder Cables	8-27
8.5	Relay Encoder Cable of 30 m to 50 m	8-29
8.5.1	SGM7D Encoder Cables	8-29
8.5.2	Encoder Cables for SGM7E and SGM7F Servomotors	8-31
8.5.3	SGM7F Encoder Cables	8-34
8.5.4	SGMCS Encoder Cables	8-37

8.6	User-Assembled Wiring Materials for Encoder Cables . .	8-39
8.6.1	SERVOPACK Connector Kits	8-39
8.6.2	Encoder Connector Kits	8-39
8.6.3	Cables without Connectors	8-40
8.7	Wiring Precautions	8-41

8.1 Cable Configurations

8.1.1 SGM7D Servomotors

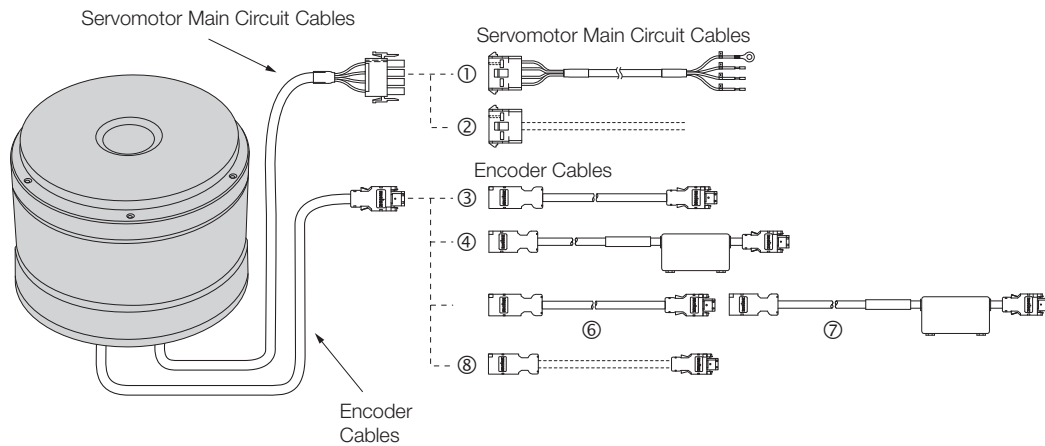

No.	Cable Type		Reference
①	Servomotor Main Circuit Cables		page 8-7
②	User-Assembled Wiring Materials for Servomotor Main Circuit Cables	Connectors	page 8-12
		Cables without Connectors	page 8-16
③	Encoder Cables of 20 m or Less		page 8-18
④	Encoder Cables of 20 m or Less with Battery Cases		
⑥	Relay Encoder Cables		page 8-29
⑦	Relay Encoder Cables with a Battery Case		
⑧	User-Assembled Wiring Materials for Encoder Cables	Connectors	page 8-39
		Cables without Connectors	page 8-40

Note: 1. The maximum wiring length is 50 m for Servomotor Main Circuit Cables and Encoder Cables.

2. If the Encoder Cable length exceeds 20 m, be sure to also connect Relay Cables as shown at ⑥ and ⑦ in the above diagram.

3. When you fabricate the Encoder Cable, always connect the shield wire from the Encoder Cable to the connector (shell). There is a risk of failure or malfunction.

8.1.2 SGM7E Motors and SGM7F-□□A to -□□D Motors

Flange Specification 1

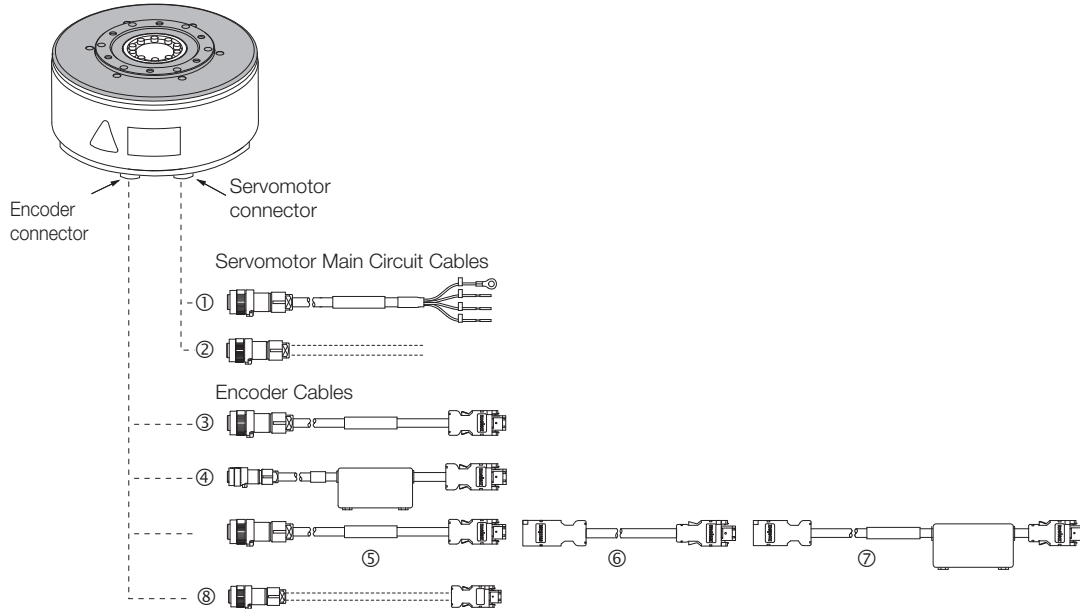

Flange Specification 4

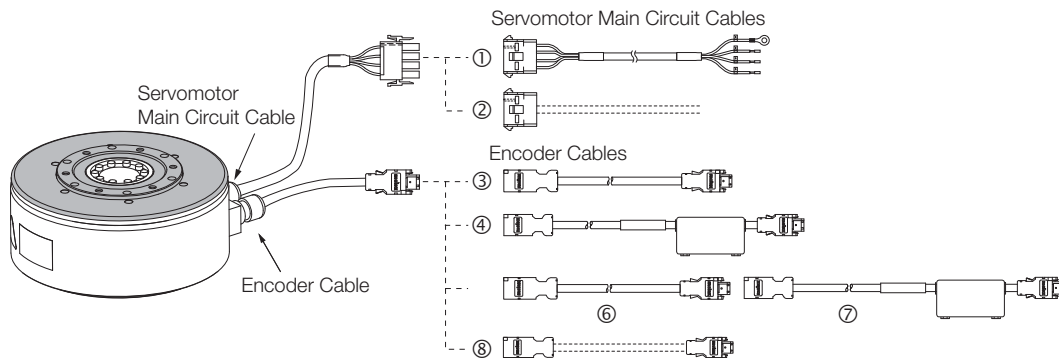

No.	Cable Type		Reference
①	Servomotor Main Circuit Cables		page 8-8
②	User-Assembled Wiring Materials for Servomotor Main Circuit Cables	Connectors	page 8-13
		Cables without Connectors	page 8-17
③	Encoder Cables of 20 m or Less		page 8-20
④	Encoder Cables of 20 m or Less with Battery Cases		
⑤	Motor-End Relay Encoder Cables		page 8-31
⑥	SERVOPACK-End Relay Encoder Cables		
⑦	Relay Encoder Cables with a Battery Case		
⑧	User-Assembled Wiring Materials for Encoder Cables	Connectors	page 8-39
		Cables without Connectors	page 8-40

- Note: 1. The maximum wiring length is 50 m for Servomotor Main Circuit Cables and Encoder Cables.
 2. If the Encoder Cable length exceeds 20 m, be sure to also connect Relay Encoder Cables as shown in the above diagram, at ⑤ to ⑦ for flange specification 1 and at ⑥ and ⑦ for flange specification 4.
 3. When you fabricate the Encoder Cable, always connect the shield wire from the Encoder Cable to the connector (shell). There is a risk of failure or malfunction.

8.1.3 SGM7F-□□M and -□□N Motors and SGMCS Motors

Flange Specification 1 or 3

Small-Capacity, Coreless Servomotors

Medium-Capacity Servomotors with Cores

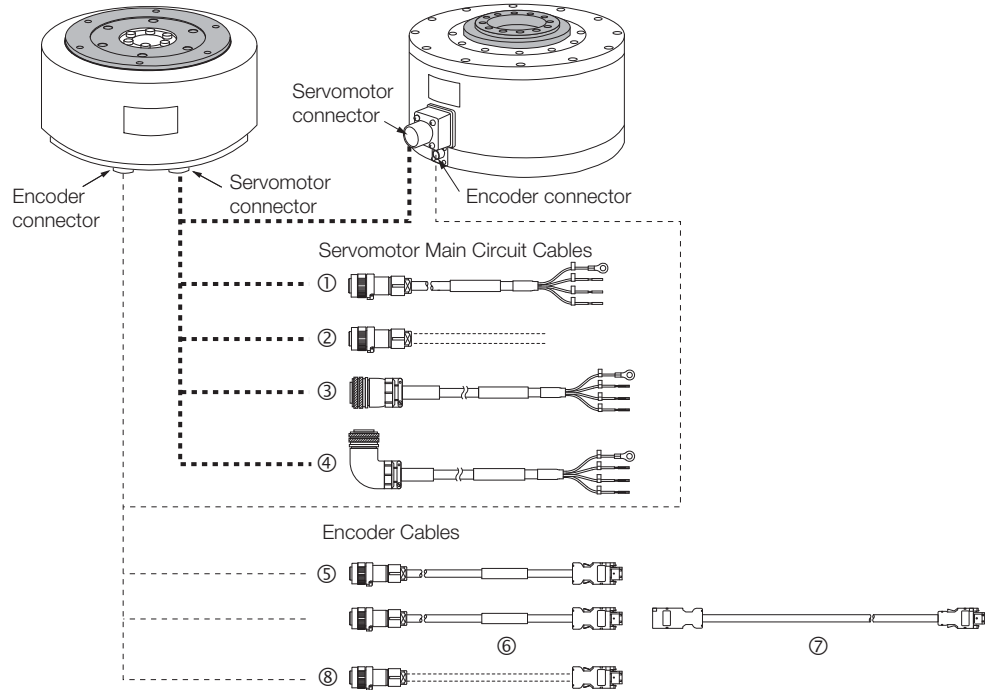

Flange Specification 4

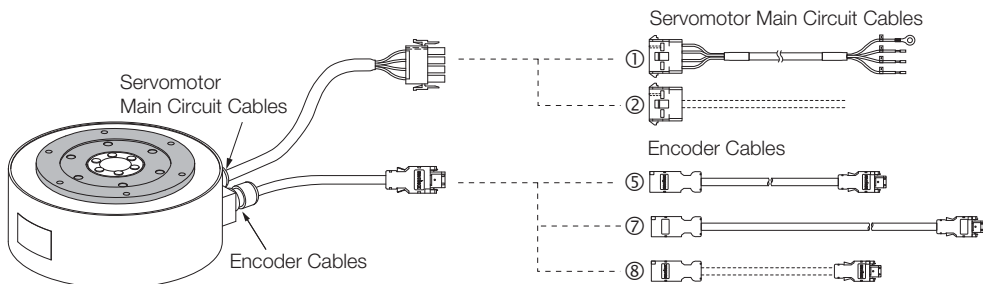

No.	Cable Type		Reference
①	Servomotor Main Circuit Cables		page 8-9
②	User-Assembled Wiring Materials for Servomotor Main Circuit Cables	Connectors	page 8-13
		Cables without Connectors	page 8-17
③	Servomotor Main Circuit Cables with Straight Plugs		page 8-9
④	Servomotor Main Circuit Cables with Right-Angle Plugs		page 8-9
⑤	Encoder Cables of 20 m or Less		page 8-27
⑥	Motor-End Relay Encoder Cables		page 8-37
⑦	SERVOPACK-End Relay Encoder Cables		page 8-37
⑧	User-Assembled Wiring Materials for Encoder Cables	Connectors	page 8-39
		Cables without Connectors	page 8-40

Note: 1. The maximum wiring length is 50 m for Servomotor Main Circuit Cables and Encoder Cables.

2. If the Encoder Cable length exceeds 20 m for flange specifications 1 or 3, be sure to also connect Relay Encoder Cables as shown at ⑥ and ⑦ in the above diagram.

3. When you fabricate the Encoder Cable, always connect the shield wire from the Encoder Cable to the connector (shell). There is a risk of failure or malfunction.

8.1.4 SGMCV Servomotors

Flange Specification 1

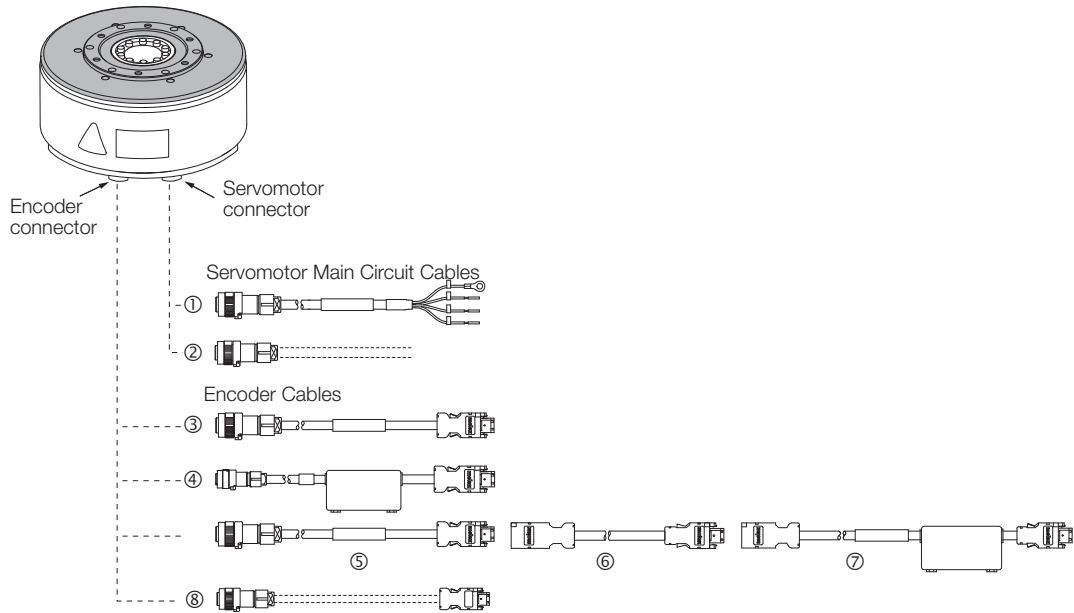

Flange Specification 4

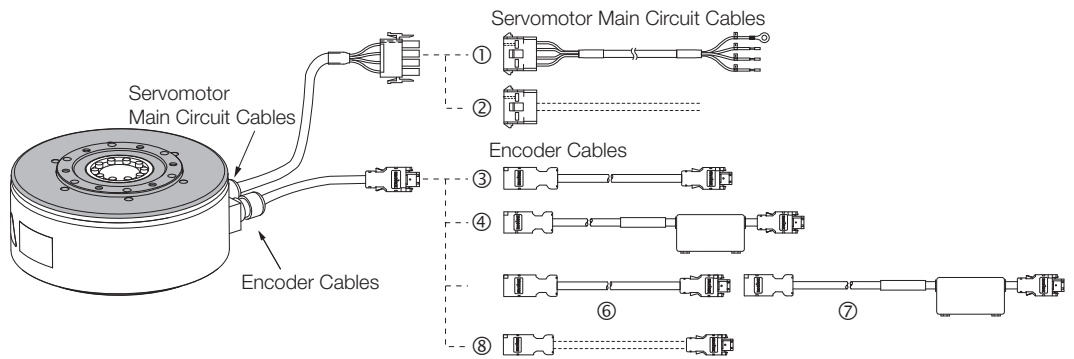

No.	Cable Type		Reference
①	Servomotor Main Circuit Cables		page 8-11
②	User-Assembled Wiring Materials for Servomotor Main Circuit Cables	Connectors	page 8-13
		Cables without Connectors	page 8-17
③	Encoder Cables of 20 m or Less		page 8-24
④	Encoder Cables of 20 m or Less with Battery Cases		
⑤	Motor-End Relay Encoder Cables		page 8-34
⑥	SERVOPACK-End Relay Encoder Cables		
⑦	Relay Encoder Cables with a Battery Case		
⑧	User-Assembled Wiring Materials for Encoder Cables	Connectors	page 8-39
		Cables without Connectors	page 8-40

Note: 1. The maximum wiring length is 50 m for Servomotor Main Circuit Cables and Encoder Cables.
 2. If the Encoder Cable length exceeds 20 m, be sure to also connect Relay Encoder Cables as shown in the above diagram, at ⑤ to ⑦ for flange specification 1 and at ⑥ and ⑦ for flange specification 4.
 3. When you fabricate the Encoder Cable, always connect the shield wire from the Encoder Cable to the connector (shell). There is a risk of failure or malfunction.

8.2 Servomotor Main Circuit Cables

8.2.1 SGM7D Servomotor Main Circuit Cables

Selection Table

Servomotor Model	Length (L)	Order Number*1		Appearance
		Standard Cable	Flexible Cable*2*3	
SGM7D-□□F, SGM7D-08G to -45G, SGM7D-□□I, SGM7D-□□J, or SGM7D-□□L	3 m, 5 m, 10 m, 15 m, and 20 m	JZSP-CMM00-□□-E	JZSP-C7DM21-□□-E	
SGM7D-01G, SGM7D-05G, SGM7D-□□H, or SGM7D-□□K	3 m, 5 m, 10 m, 15 m, and 20 m	JZSP-CMM00-□□-E	JZSP-CMM01-□□-E	

*1. Replace the boxes (□□) in the order number with the cable length (03, 05, 10, 15, or 20).

*2. Use Flexible Cables for moving parts of machines, such as robots.

*3. The recommended bending radius (R) is 90 mm or larger.

Note: 1. Refer to the following section for information on connector specifications, manufacturers, and order numbers.

[SGM7D Servomotors on page 8-12](#)

2. Refer to the following section for information on wiring material specifications and order numbers.

[SGM7D Main Circuit Cables on page 8-16](#)

Wiring Specifications

SERVOPACK end		Motor end	
Wire Color	Signal	Signal	Pin
Red	Phase U	Phase U	1
Gray	Phase V	Phase V	2
Blue	Phase W	Phase W	3
Green/(yellow)	FG	FG	4

8.2.2 Main Circuit Cables for SGM7E and SGM7F-□□A to -□□D Motors

Selection Table

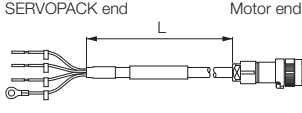
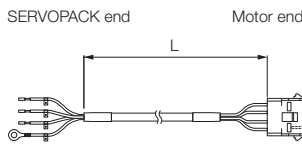
Servomotor Model	Flange Specification Code (6th Digit in Model Number)	Length (L)	Order Number*1		Appearance
			Standard Cable	Flexible Cable*2, *3	
SGM7E-□□□ SGM7F-□□A to -□□D	1 Non-load side installation	3 m, 5 m, 10 m, 15 m, and 20 m	JZSP-CMM60-□□-E	JZSP-C7MDN23-□□-E	
	4 Non-load side installation (with cable on side)		JZSP-CMM00-□□-E	JZSP-C7MDS23-□□-E	

*1. Replace the boxes (□□) in the order number with the cable length (03, 05, 10, 15, or 20).

*2. Use Flexible Cables for moving parts of machines, such as robots.

*3. The recommended bending radius (R) is 90 mm or larger.

Note: 1. Refer to the following section for information on connector specifications, manufacturers, and order numbers.

 SGM7E Servomotors, SGM7F-□□A to -□□D Servomotors, SGMCV Servomotors, and SGMCS Small-Capacity, Coreless Servomotor on page 8-13

2. Refer to the following section for information on wiring material specifications and order numbers.

 Main Circuit Cables for SGM7E Servomotors and SGMCS Small-Capacity, Coreless Servomotors on page 8-17



 Main Circuit Cables for SGM7F-□□A to -□□D Servomotors and SGMCV Servomotors on page 8-17

Wiring Specifications

SERVOPACK end		Motor end	
Wire Color	Signal	Signal	Pin
Red	Phase U	Phase U	1
White	Phase V	Phase V	2
Blue	Phase W	Phase W	3
Green/(yellow)	FG	FG	4

8.2.3 Main Circuit Cables for SGM7F-□□M, -□□N, and SGMCS Motors

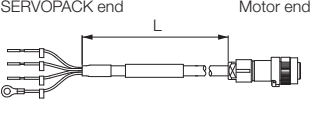
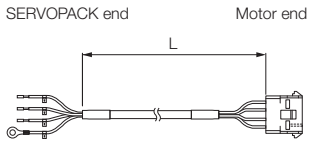
Selection Table

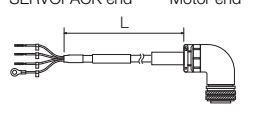
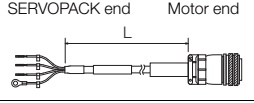
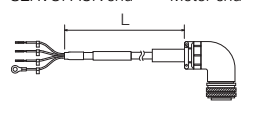
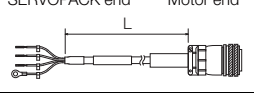
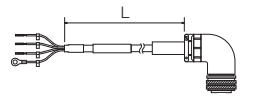
Servomotor Model	Flange Specification Code (6th Digit in Model Number)	Connector Type	Length (L)	Order Number* ¹		Appearance
				Standard Cable	Flexible Cable* ^{2, 3}	
SGMCS-□□B SGMCS-□□C SGMCS-□□D SGMCS-□□E	1 Non-load side installation	-	3 m, 5 m, 10 m, 15 m, and 20 m	JZSP-CMM60-□□-E	JZSP-CSM60-□□-E	
	4 Non-load side installation (with cable on side)			JZSP-CMM00-□□-E	JZSP-CMM01-□□-E	
SGM7F-□□M SGM7F-□□N SGMCS-□□M SGMCS-□□N □□: 45 □□: 80	1 Load side installation and 3 Non-load side installation	Straight		JZSP-USA101-□□-E	JZSP-USA121-□□-E	
		Right-angle		JZSP-USA102-□□-E	JZSP-USA122-□□-E	
SGM7F-□□M SGM7F-□□N SGMCS-□□M SGMCS-□□N □□: 1A	1 Load side installation and 3 Non-load side installation	Straight		JZSP-USA301-□□-E	JZSP-USA321-□□-E	
		Right-angle		JZSP-USA302-□□-E	JZSP-USA322-□□-E	
SGM7F-□□M SGM7F-□□N SGMCS-□□M SGMCS-□□N □□: 1E □□: 2Z	1 Load side installation and 3 Non-load side installation	Straight		JZSP-USA501-□□-E	JZSP-USA521-□□-E	
		Right-angle		JZSP-USA502-□□-E	JZSP-USA522-□□-E	

*1. Replace the boxes (□□) in the order number with the cable length (03, 05, 10, 15, or 20).

*2. Use Flexible Cables for moving parts of machines, such as robots.

*3. The recommended bending radius of the Flexible Cables are given in the following table.

Order Number	Recommended Bending Radius (R)	Order Number	Recommended Bending Radius (R)
JZSP-CSM60-□□-E	55 mm min.	JZSP-USA321-□□-E	113 mm min.
JZSP-CMM01-□□-E		JZSP-USA322-□□-E	
JZSP-USA121-□□-E	96 mm min.	JZSP-USA521-□□-E	150 mm min.
JZSP-USA122-□□-E		JZSP-USA522-□□-E	

8.2.3 Main Circuit Cables for SGM7F-□□M, -□□N, and SGMCS Motors

Note: 1. Refer to the following section for information on connector specifications, manufacturers, and order numbers.

 SGM7E Servomotors, SGM7F-□□A to -□□D Servomotors, SGMCV Servomotors, and SGMCS Small-Capacity, Coreless Servomotor on page 8-13

 SGM7F-□□M or -□□N Servomotors and SGMCS Medium-Capacity Servomotors with Cores on page 8-14

2. Refer to the following section for information on wiring material specifications and order numbers.

 Main Circuit Cables for SGM7E Servomotors and SGMCS Small-Capacity, Coreless Servomotors on page 8-17

Yaskawa does not specify what wiring materials to use for SGM7F-□□M and -□□N Servomotors and SGMCS Medium-Capacity Servomotors with Cores. Use appropriate wiring materials for the current specifications and connectors.

Wiring Specifications

◆ JZSP-C□M□□-□□-E (Standard/Flexible Cables)

SERVOPACK end		Motor end	
Wire Color	Signal	Signal	Pin
Red	Phase U	Phase U	1
White	Phase V	Phase V	2
Blue	Phase W	Phase W	3
Green/(yellow)	FG	FG	4

◆ JZSP-USA10□-□□-E, JZSP-USA30□-□□-E, and JZSP-USA50□-□□-E (Standard Cables)

SERVOPACK end		Motor end	
Wire Color	Signal	Signal	Pin
Red	Phase U	Phase U	A
White	Phase V	Phase V	B
Black	Phase W	Phase W	C
Green	FG	FG	D

◆ JZSP-USA12□-□□-E, JZSP-USA32□-□□-E, and JZSP-USA52□-□□-E (Flexible Cables)

SERVOPACK end		Motor end	
Wire Color	Signal	Signal	Pin
Red	Phase U	Phase U	A
White	Phase V	Phase V	B
Blue	Phase W	Phase W	C
Green/yellow	FG	FG	D

8.2.4 SGMCV Servomotor Main Circuit Cables

Selection Table

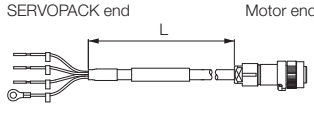
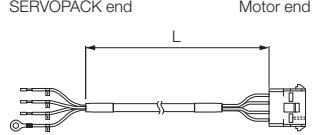
Servomotor Model	Flange Specification Code (6th Digit in Model Number)	Length (L)	Order Number* ¹		Appearance
			Standard Cable	Flexible Cable* ^{2, *3}	
SGM7E-□□B SGM7E-□□C SGM7E-□□D	1 Non-load side installation	3 m, 5 m, 10 m, 15 m, and 20 m	JZSP-CMM60-□□-E	JZSP-C7MDN23-□□-E	
	4 Non-load side installation (with cable on side)		JZSP-CMM00-□□-E	JZSP-C7MDS23-□□-E	

*1. Replace the boxes (□□) in the order number with the cable length (03, 05, 10, 15, or 20).

*2. Use Flexible Cables for moving parts of machines, such as robots.

*3. The recommended bending radius (R) is 90 mm or larger.

Note: 1. Refer to the following section for information on connector specifications, manufacturers, and order numbers.

 SGM7E Servomotors, SGM7F-□□A to -□□D Servomotors, SGMCV Servomotors, and SGMCS Small-Capacity, Coreless Servomotor on page 8-13

2. Refer to the following section for information on wiring material specifications and order numbers.

 Main Circuit Cables for SGM7F-□□A to -□□D Servomotors and SGMCV Servomotors on page 8-17

Wiring Specifications

SERVOPACK end		Motor end	
Wire Color	Signal	Signal	Pin
Red	Phase U	Phase U	1
White	Phase V	Phase V	2
Blue	Phase W	Phase W	3
Green/(yellow)	FG	FG	4

8.3 User-Assembled Wiring Materials for Servomotor Main Circuit Cables

8.3.1 Servomotor Connector Kits

SGM7D Servomotors

◆ SGM7D-01G, -05G, -□□H, and -□□K
(for Standard or Flexible Cables)

Item		Description	External Dimensions [mm]
Manufacturer		TE Connectivity Japan G.K.	
Order Number		JZSP-CMM9-3-E	
Components	Cap	350780-1	
	Socket	Reeled Sockets: 350570-3, Loose Sockets: 350689-3	
Applicable Wire Sizes		AWG18 to AWG24	
Crimping Tool*	Hand Tool	91510-1	

* A Crimping Tool is required. Contact the connector manufacturer for details.

Note: Cables are not included. Purchase them separately.

◆ SGM7D-□□F, -□□G (Excluding -01G and -05G), -□□I, -□□J,
and -□□L (for Standard or Flexible Cables)

Item		Description	External Dimensions [mm]
Manufacturer		TE Connectivity Japan G.K.	
Order Number		JZSP-CMM9-3-E	
Components	Cap	350780-1	
	Socket	Reeled Sockets: 350536-3, Loose Sockets: 350550-3	
Applicable Wire Sizes		AWG14 to AWG20	
Crimping Tool*	Hand Tool	91500-1	

* A Crimping Tool is required. Contact the connector manufacturer for details.

Note: Cables are not included. Purchase them separately.

SGM7E Servomotors, SGM7F-□□A to -□□D Servomotors, SGMCV Servomotors, and SGMCS Small-Capacity, Core-less Servomotor

◆ Connectors for Flange Specification 1 (for Standard or Flexible Cables)

Item	Description	External Dimensions [mm]
Manufacturer	Japan Aviation Electronics Industry, Ltd.	
Order Number	JN1DS04FK1 (soldered)	
Applicable Cable Diameter	5.7 mm to 7.3 mm	

Note: Cables are not included. Purchase them separately.

◆ Connector Kits for Flange Specification 4 (for Standard or Flexible Cables)

Item	Description	External Dimensions [mm]	
Manufacturer	TE Connectivity Japan G.K.		
Order Number	JZSP-CMM9-3-E		
Components	Cap		350780-1
	Socket		Reeled Sockets: 350570-3, Loose Sockets: 350689-3
Applicable Wire Sizes	AWG18 to AWG24		
Crimping Tool*	Hand Tool		91510-1

* A Crimping Tool is required. Contact the connector manufacturer for details.

Note: Cables are not included. Purchase them separately.

SGM7F-□□M or -□□N Servomotors and SGMCS Medium-Capacity Servomotors with Cores

◆ Connector Configurations

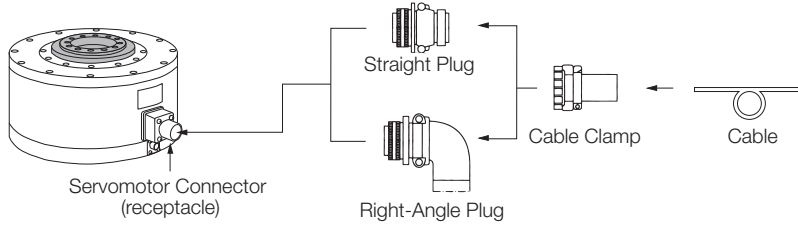

Servomotor Model	Servomotor Connector Model (Receptacle)	Order Number			Manufacturer
SGMCS-□□M SGMCS-□□N	CE05-2A18-10PD-D (MS Connector model: MS3102A18-10P)	N/MS3106B18-10S	N/MS3108B18-10S	N/MS3057-10A	Japan Aviation Electronics Industry, Ltd.

Note: 1. Servomotor Connectors (receptacles) are compatible with MS Connectors. If you prepare your own cables, refer to the connector number in parentheses for the model number of the MS connector and select the appropriate plug.

2. Yaskawa does not specify what wiring materials to use. Use appropriate wiring materials for the current specifications and connectors.

◆ External Dimensions

■ Straight Plugs: N/MS3106B18-10S

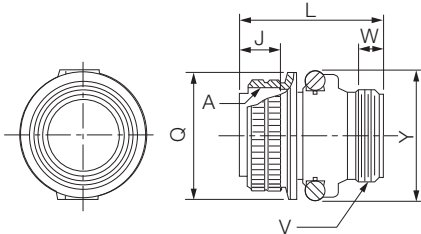

Unit: mm

Part	Shell Size	Joint Thread A	Length of Joint J ±0.12	Total Length L Max.	Joint Nut Outer Diameter Q ⁺⁰ / _{-0.38} Dia.	Cable Clamp Mounting Thread V	Effective Thread Length W Min.	Maximum Width Y Max.
N/MS3106B18-10S	18	1-1/8-18UNEF	18.26	52.37	34.13	1-20UNEF	9.53	42

■ Right-Angle Plug: N/MS3108B18-10S

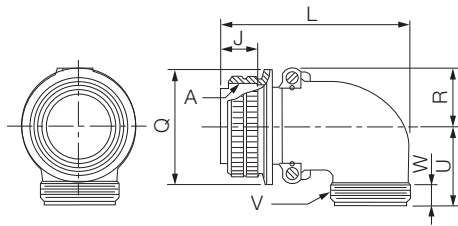

Unit: mm

Part	Shell Size	Joint Thread A	Length of Joint J ± 0.12	Total Length L Max.	Joint Nut Outer Diameter Q $^{+0}_{-0.38}$ Dia.	R ± 0.5	U ± 0.5	Cable Clamp Mounting Thread V	Effective Thread Length W Min.
N/MS3108B18-10S	18	1-1/8-18UNEF	18.26	68.27	34.13	20.5	30.2	1-20UNEF	9.53

■ Cable Clamp: N/MS3057-10A

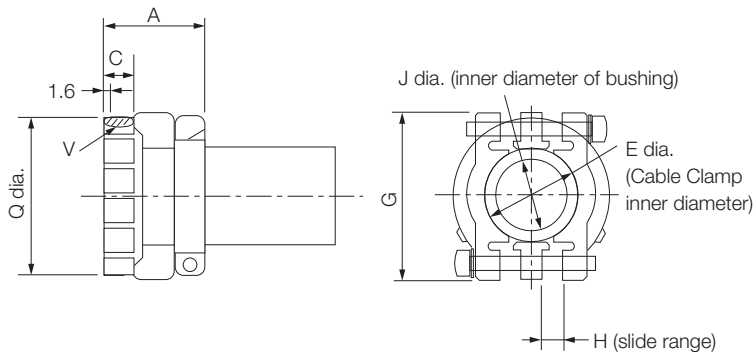

Unit: mm

Part	Applicable Connector Shell Size	Total Length A ± 0.7	Effective Thread Length C	E Dia.	G ± 0.7	H	J Dia.	Mounting Thread V	Outer Diameter Q ± 0.7 Dia.	Attached Bushing
N/MS3057-10A	18	23.8	10.3	15.9	31.7	3.2	14.3	1-20UNEF	30.1	AN3420-10

Note: A rubber bushing is included.

8.3.2 Cables without Connectors

SGM7D Main Circuit Cables

◆ SGM7D-01G, -05G, -□□H, and -□□K

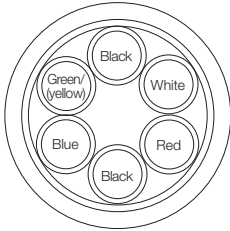
Item	Standard Cable	Flexible Cable
Order Number*	JZSP-CSM90-□□-E	JZSP-CSM80-□□-E
Specifications	UL2517 (rated temperature: 105°C) AWG20 × 6C	UL2517 (rated temperature: 105°C) AWG22 × 6C
	AWG20 (0.52 mm ²) Outer diameter of insulating sheath: 1.53 mm	AWG22 (0.33 mm ²) Outer diameter of insulating sheath: 1.37 mm
Finished Diameter	7 mm ± 0.3 mm	
Internal Structure and Lead Colors		

* Replace the boxes (□□) in the order number with the cable length (05, 10, 15, 20, 30, 40, or 50).

◆ SGM7D-□□F, -□□G (Excluding -01G and -05G), -□□I, -□□J, and -□□L

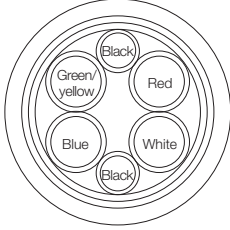
Item	Standard Cable	Flexible Cable
Order Number*	JZSP-CSM91-□□-E	JZSP-CSM81-□□-E
Specifications	UL2517 (rated temperature: 105°C) AWG16 × 4C, AWG20 × 2C	UL2517 (rated temperature: 105°C) AWG16 × 4C, AWG22 × 2C
	Power lines: AWG16 (1.31 mm ²) Outer diameter of insulating sheath: 2.15 mm	Power lines: AWG16 (1.31 mm ²) Outer diameter of insulating sheath: 2.35 mm
Finished Diameter	8 mm ± 0.3 mm	
Internal Structure and Lead Colors		

* Replace the boxes (□□) in the order number with the cable length (05, 10, 15, 20, 30, 40, or 50).

Main Circuit Cables for SGM7E Servomotors and SGMCS Small-Capacity, Coreless Servomotors

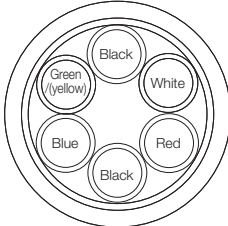
Item	Standard Cable	Flexible Cable
Order Number*	JZSP-CSM90-□□-E	JZSP-CSM80-□□-E
Specifications	UL2517 (rated temperature: 105°C) AWG20 × 6C	UL2517 (rated temperature: 105°C) AWG22 × 6C
	AWG20 (0.52 mm ²) Outer diameter of insulating sheath: 1.53 mm	AWG22 (0.33 mm ²) Outer diameter of insulating sheath: 1.37 mm
Finished Diameter	7 mm ±0.3 mm	
Internal Structure and Lead Colors		

* Replace the boxes (□□) in the order number with the cable length (05, 10, 15, 20, 30, 40, or 50).

Main Circuit Cables for SGM7F-□□A to -□□D Servomotors and SGMCV Servomotors

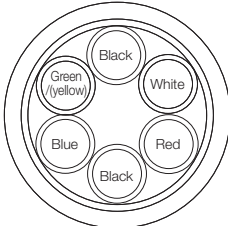
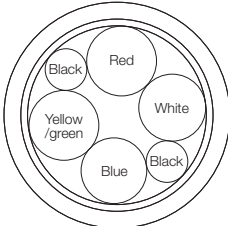
Item	Standard Cable	Flexible Cable
Order Number*	JZSP-CSM90-□□-E	JZSP-C7M29-□□-E
Specifications	UL2517 (rated temperature: 105°C) AWG20 × 6C	UL2517 (rated temperature: 105°C) AWG20 × 4C, AWG22C × 2C
	AWG20 (0.52 mm ²) Outer diameter of insulating sheath: 1.53 mm	AWG20 (0.52 mm ²) Outer diameter of insulating sheath: 1.37 mm
Finished Diameter	7 mm ±0.3 mm	7 mm ±0.2 mm
Internal Structure and Lead Colors		

* Replace the boxes (□□) in the order number with the cable length (05, 10, 15, 20, 30, 40, or 50).

8.4 Encoder Cables of 20 m or Less

8.4.1 SGM7D Encoder Cables

NOTICE

- Install a battery at either the host controller or on the Encoder Cable.
If you install batteries both at the host controller and on the Encoder Cable at the same time, you will create a loop circuit between the batteries, resulting in a risk of damage or burning.

Selection Table

Servomotor Model	Serial Encoder Specification	Length (L)	Order Number*1		Appearance
			Standard Cable	Flexible Cable*2, *3	
SGM7D	For incremental encoder: Without Battery Case	3 m, 5 m, 10 m, 15 m, and 20 m	JZSP-CMP00-□□-E	JZSP-CMP10-□□-E	
	For multiturn absolute encoder: Without Battery Case*4		JZSP-CMP00-□□-E	JZSP-CMP10-□□-E	
	For multiturn absolute encoder: With Battery Case		JZSP-CSP19-□□-E	JZSP-CSP29-□□-E	

*1. Replace the boxes (□□) in the order number with the cable length (03, 05, 10, 15, or 20).

*2. Use Flexible Cables for moving parts of machines, such as robots.

*3. The recommended bending radius (R) is 46 mm or larger.

*4. Use one of these Cables if a battery is installed at the host controller.

Note: 1. Refer to the following section for information on connector specifications, manufacturers, and order numbers.

8.6.1 *SERVOPACK Connector Kits* on page 8-39

8.6.2 *Encoder Connector Kits* on page 8-39

2. Refer to the following section for information on wiring material specifications and order numbers.

8.6.3 *Cables without Connectors* on page 8-40

Wiring Specifications

◆ JZSP-CMP00-□□-E (Standard Cables) and JZSP-CMP10-□□-E (Flexible Cables)

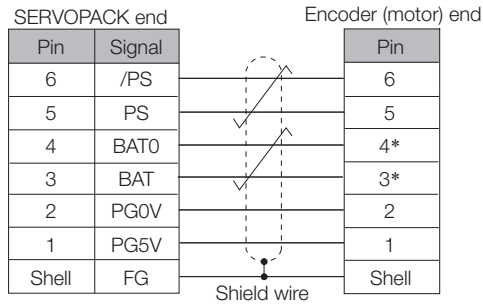

* A battery is required only for a multiturn absolute encoder.

◆ JZSP-CSP19-□□-E (Standard Cables) and JZSP-CSP29-□□-E (Flexible Cables)

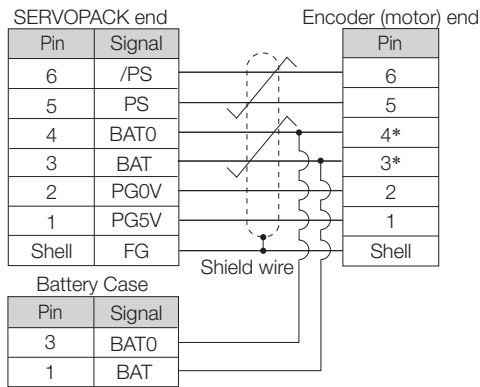

* A battery is required only for a multiturn absolute encoder.

8.4.2 Encoder Cables for SGM7E and SGM7F Servomotors

NOTICE

- Install a battery at either the host controller or on the Encoder Cable.
If you install batteries both at the host controller and on the Encoder Cable at the same time, you will create a loop circuit between the batteries, resulting in a risk of damage or burning.

Selection Table

◆ SGM7E and SGM7F-□□A to -□□D

Servomotor Model	Serial Encoder Specification	Flange Specification Code (6th Digit in Model Number)	Length (L)	Order Number*1		Appearance
				Standard Cable	Flexible Cable*2, *3	
SGM7E-□□□F SGM7F-□□□AF to -□□□DF	For incremental encoder	1 Non-load side installation	3 m, 5 m, 10 m, 15 m, and 20 m	JZSP-CMP60-□□-E	JZSP-CSP60-□□-E	
		4 Non-load side installation (with cable on side)		JZSP-CMP00-□□-E	JZSP-CMP10-□□-E	
For multi-turn absolute encoder: Without Battery Case*4	1 Non-load side installation	JZSP-C7PI00-□□-E		JZSP-C7PI20-□□-E		
	For multi-turn absolute encoder: With Battery Case	JZSP-C7PA00-□□-E		JZSP-C7PA20-□□-E		
		4 Non-load side installation (with cable on side)		JZSP-CMP00-□□-E	JZSP-CMP10-□□-E	
For multi-turn absolute encoder: With Battery Case	1 Non-load side installation	JZSP-CSP19-□□-E		JZSP-CSP29-□□-E		
	4 Non-load side installation (with cable on side)	JZSP-CSP19-□□-E		JZSP-CSP29-□□-E		

*1. Replace the boxes (□□) in the order number with the cable length (03, 05, 10, 15, or 20).

*2. Use Flexible Cables for moving parts of machines, such as robots.

*3. The recommended bending radius (R) is 46 mm or larger.

*4. Use one of these Cables if a battery is installed at the host controller.

Note: 1. Refer to the following section for information on connector specifications, manufacturers, and order numbers.

8.6.1 *SERVOPACK Connector Kits* on page 8-39

8.6.2 *Encoder Connector Kits* on page 8-39

2. Refer to the following section for information on wiring material specifications and order numbers.

8.6.3 *Cables without Connectors* on page 8-40

◆ SGM7F-□□M and -□□N

Servomotor Model	Serial Encoder Specification	Flange Specification Code (6th Digit in Model Number)	Length (L)	Order Number*1		Appearance
				Standard Cable	Flexible Cable*2, *3	
SGM7F-□□MF and -□□NF	For incremental encoder	1 Load side installation or 3 Non-load side installation	3 m, 5 m, 10 m, 15 m, and 20 m	JZSP-CMP60-□□-E	JZSP-CSP60-□□-E	
		1 Load side installation or 3 Non-load side installation		JZSP-C7PI00-□□-E	JZSP-C7PI20-□□-E	
SGM7F-□□M7 and -□□N7	For multi-turn absolute encoder: Without Battery Case*4	1 Load side installation or 3 Non-load side installation		JZSP-C7PA00-□□-E	JZSP-C7PA20-□□-E	
	For multi-turn absolute encoder: With Battery Case	1 Load side installation or 3 Non-load side installation		JZSP-C7PA00-□□-E	JZSP-C7PA20-□□-E	

*1. Replace the boxes (□□) in the order number with the cable length (03, 05, 10, 15, or 20).

*2. Use Flexible Cables for moving parts of machines, such as robots.

*3. The recommended bending radius (R) is 46 mm or larger.

*4. Use one of these Cables if a battery is installed at the host controller.

Note: 1. Refer to the following section for information on connector specifications, manufacturers, and order numbers.

8.6.1 *SERVOPACK Connector Kits* on page 8-39

8.6.2 *Encoder Connector Kits* on page 8-39

2. Refer to the following section for information on wiring material specifications and order numbers.

8.6.3 *Cables without Connectors* on page 8-40

Wiring Specifications

◆ JZSP-CMP60-□□-E (Standard Cables) and JZSP-CSP60-□□-E (Flexible Cables)

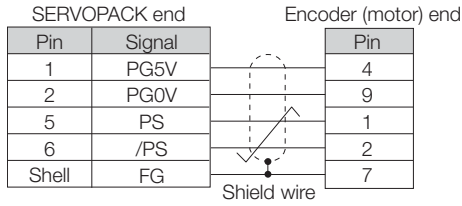

◆ JZSP-CMP00-□□-E (Standard Cables) and JZSP-CMP10-□□-E (Flexible Cables)

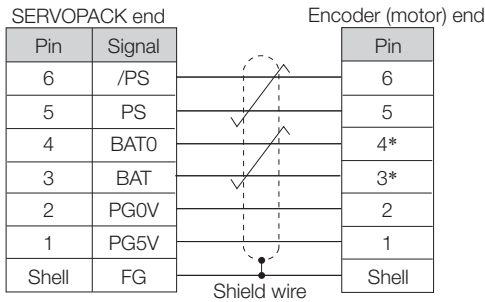

* A battery is required only for a multiturn absolute encoder.

◆ JZSP-C7PI00-□□-E (Standard Cables) and JZSP-C7PI20-□□-E (Flexible Cables)

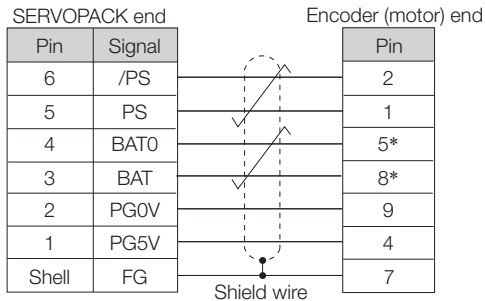

* A battery is required only for a multiturn absolute encoder.

◆ JZSP-C7PA00-□□-E (Standard Cables) and JZSP-C7PA20-□□-E (Flexible Cables)

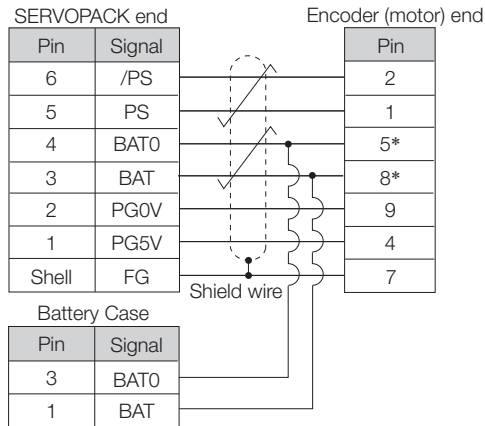

* A battery is required only for a multiturn absolute encoder.

◆ JZSP-CSP19-□□-E (Standard Cables) and JZSP-CSP29-□□-E (Flexible Cables)

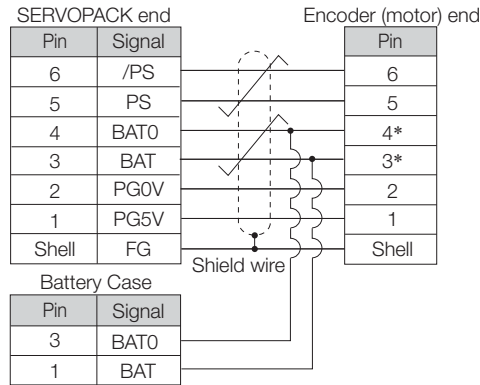

* A battery is required only for a multiturn absolute encoder.

8.4.3 SGMCV Encoder Cables

NOTICE

- Install a battery at either the host controller or on the Encoder Cable.
If you install batteries both at the host controller and on the Encoder Cable at the same time, you will create a loop circuit between the batteries, resulting in a risk of damage or burning.

Selection Table

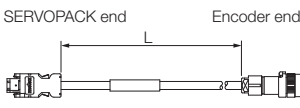
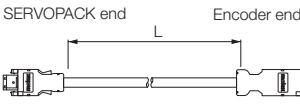
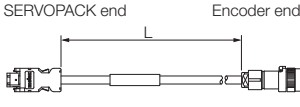
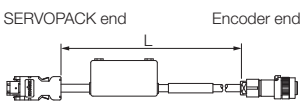
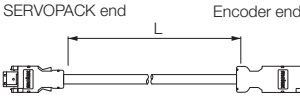
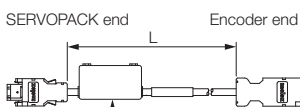
Servomotor Model	Serial Encoder Specification	Flange Specification Code (6th Digit in the Model Number)	Length (L)	Order Number*1		Appearance
				Standard Cable	Flexible Cable *2, *3	
SGMCV-□□□E	For single-turn absolute encoder: Without Battery Case	1 Non-load side installation	3 m, 5 m, 10 m, 15 m, and 20 m	JZSP-CMP60-□□-E	JZSP-CSP60-□□-E	
		4 Non-load side installation (with cable on side)		JZSP-CMP00-□□-E	JZSP-CMP10-□□-E	
For multi-turn absolute encoder: Without Battery Case*4	1 Non-load side installation	JZSP-C7PI00-□□-E		JZSP-C7PI20-□□-E		
		JZSP-C7PA00-□□-E		JZSP-C7PA20-□□-E		
SGMCV-□□□I	For multi-turn absolute encoder: Without Battery Case*4	4 Non-load side installation (with cable on side)		JZSP-CMP00-□□-E	JZSP-CMP10-□□-E	
				JZSP-CSP19-□□-E	JZSP-CSP29-□□-E	
		For multi-turn absolute encoder: With Battery Case				

*1. Replace the boxes (□□) in the order number with the cable length (03, 05, 10, 15, or 20).

*2. Use Flexible Cables for moving parts of machines, such as robots.

*3. The recommended bending radius (R) is 46 mm or larger.

*4. Use one of these Cables if a battery is installed at the host controller.

Note: 1. Refer to the following section for information on connector specifications, manufacturers, and order numbers.

 8.6.1 SERVOPACK Connector Kits on page 8-39

 8.6.2 Encoder Connector Kits on page 8-39

2. Refer to the following section for information on wiring material specifications and order numbers.

 8.6.3 Cables without Connectors on page 8-40

Wiring Specifications

◆ JZSP-CMP60-□□-E (Standard Cables) and JZSP-CSP60-□□-E (Flexible Cables)

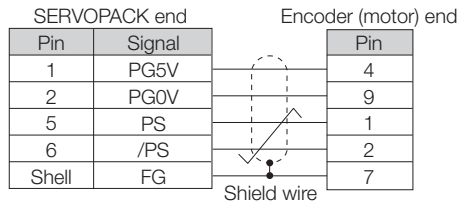

◆ JZSP-CMP00-□□-E (Standard Cables) and JZSP-CMP10-□□-E (Flexible Cables)

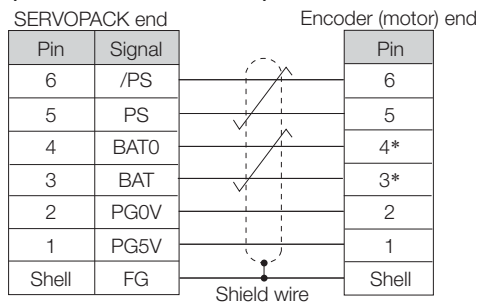

* A battery is required only for a multiturn absolute encoder.

◆ JZSP-C7PI00-□□-E (Standard Cables) and JZSP-C7PI20-□□-E (Flexible Cables)

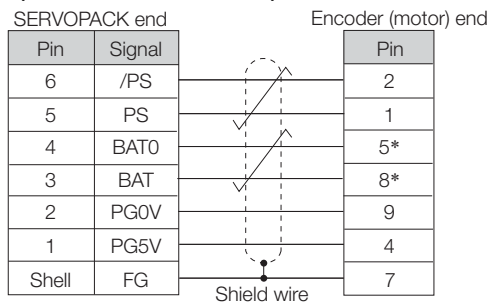

* A battery is required only for a multiturn absolute encoder.

◆ JZSP-C7PA00-□□-E (Standard Cables) and JZSP-C7PA20-□□-E (Flexible Cables)

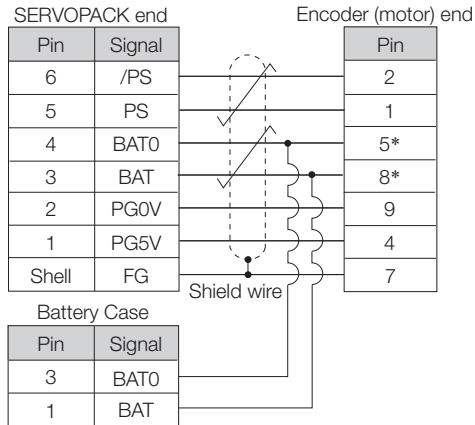

* A battery is required only for a multiturn absolute encoder.

◆ JZSP-CSP19-□□-E (Standard Cables) and JZSP-CSP29-□□-E (Flexible Cables)

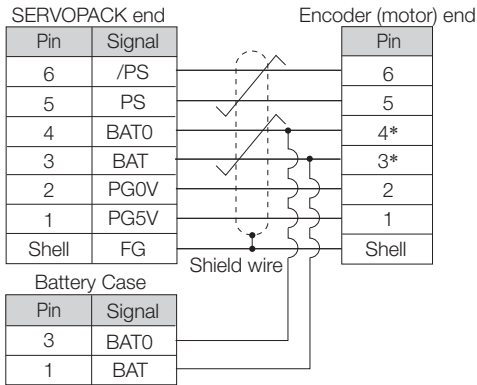

* A battery is required only for a multiturn absolute encoder.

8.4.4 SGMCS Encoder Cables

You can use the cables in the following table for either SGMCS 20-bit absolute encoders (without multiturn data) or 20-bit incremental encoders.

Selection Table

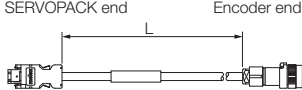
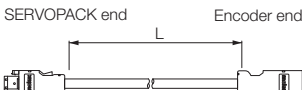
Servomotor Model	Flange Specification Code (6th Digit in the Model Number)	Length (L)	Order Number* ¹		Appearance
			Standard Cable	Flexible Cable* ^{2, *3}	
SGMCS-□□B SGMCS-□□C SGMCS-□□D SGMCS-□□E	1 Non-load side installation	3 m, 5 m, 10 m, 15 m, and 20 m	JZSP-CMP60- □□-E	JZSP-CSP60- □□-E	
SGMCS-□□M SGMCS-□□N	1 Load side installation 3 Non-load side installation				
SGMCS-□□B SGMCS-□□C SGMCS-□□D SGMCS-□□E	4 Non-load side installation (with cable on side)		JZSP-CMP00- □□-E	JZSP-CMP10- □□-E	

*1. Replace the boxes (□□) in the order number with the cable length (03, 05, 10, 15, or 20).

*2. Use Flexible Cables for moving parts of machines, such as robots.

*3. The recommended bending radius (R) is 46 mm or larger.

Note: 1. Refer to the following section for information on connector specifications, manufacturers, and order numbers.

 8.6.1 *SERVOPACK Connector Kits* on page 8-39

 8.6.2 *Encoder Connector Kits* on page 8-39

2. Refer to the following section for information on wiring material specifications and order numbers.

 8.6.3 *Cables without Connectors* on page 8-40

Wiring Specifications

◆ JZSP-CMP60-□□-E (Standard Cables) and JZSP-CSP60-□□-E (Flexible Cables)

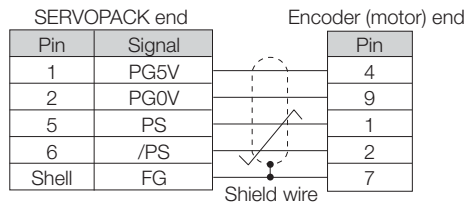

◆ JZSP-CMP00-□□-E (Standard Cables) and JZSP-CMP10-□□-E (Flexible Cables)

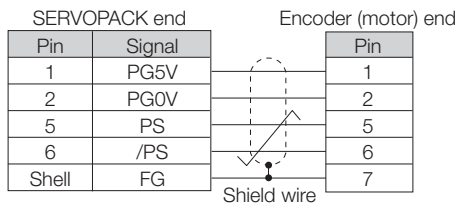

8.5 Relay Encoder Cable of 30 m to 50 m

If the Encoder Cable length exceeds 20 m, Relay Encoder Cables are used. Select the combination of Cables to use according to your system.

8.5.1 SGM7D Encoder Cables

If a battery is not mounted to the host controller, also obtain a Relay Encoder Cable with a Battery Case in addition to the Relay Encoder Cable.

NOTICE

- Install a battery at either the host controller or on the Encoder Cable.
If you install batteries both at the host controller and on the Encoder Cable at the same time, you will create a loop circuit between the batteries, resulting in a risk of damage or burning.

Relay Encoder Cables

◆ Selection Table

Specification	Length (L)	Order Number*
For incremental or multiturn absolute encoder	30 m, 40 m, or 50 m	JZSP-UCMP00-□□-E

* Replace the boxes (□□) in the order number with the cable length (30, 40, or 50).

Note: Flexible cables are not available.

◆ Appearance

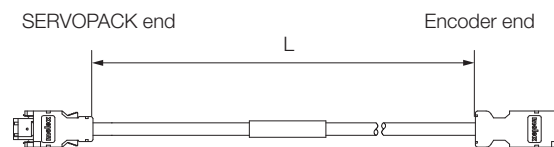

◆ Wiring Specifications

SERVOPACK end		Encoder (motor) end	
Pin	Signal	Pin	Signal
6	/PS	6	
5	PS	5	
4	BAT0	4*	
3	BAT	3*	
2	PGOV	2	
1	PG5V	1	
Shell	FG	Shell	

Shield wire

* A battery is required only for a multiturn absolute encoder.

Relay Encoder Cables with a Battery Case

◆ Selection Table

Specification	Length (L)	Order Number
For multiturn absolute encoder	0.3 m	JZSP-CSP12-E

Note: Flexible cables are not available.

◆ Appearance

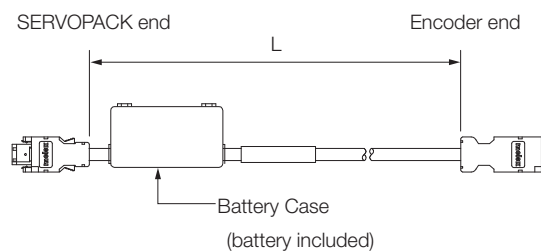

◆ Wiring Specifications

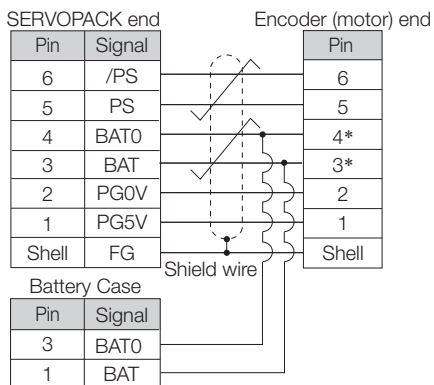

* A battery is required only for a multiturn absolute encoder.

8.5.2 Encoder Cables for SGM7E and SGM7F Servomotors

For flange specification 1 or 3, use a Motor-End Relay Encoder Cable and a SERVOPACK-End Relay Encoder Cable. For flange specification 4, use only a SERVOPACK-End Relay Encoder Cable.

If a battery is not mounted to the host controller, also obtain a Relay Encoder Cable with a Battery Case in addition to the above Cables.

NOTICE

- Install a battery at either the host controller or on the Encoder Cable.
If you install batteries both at the host controller and on the Encoder Cable at the same time, you will create a loop circuit between the batteries, resulting in a risk of damage or burning.

Motor-End Relay Encoder Cables

◆ Selection Table

Specification	Length (L)	Order Number
For incremental or multiturn absolute encoder	0.3 m	JZSP-C7PRC0-E

Note: Flexible cables are not available.

◆ Appearance

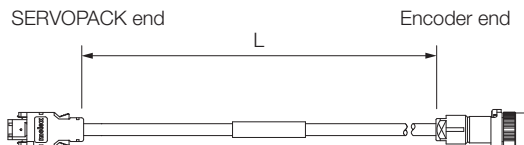

◆ Wiring Specifications

SERVOPACK end		Encoder (motor) end	
Pin	Signal	Pin	Signal
6	/PS	2	
5	PS	1	
4	BAT0	5*	
3	BAT	8*	
2	PG0V	9	
1	PG5V	4	
Shell	FG	7	

Shield wire

* A battery is required only for a multiturn absolute encoder.

SERVOPACK-End Relay Encoder Cables

◆ Selection Table

Specification	Length (L)	Order Number*
For incremental or multiturn absolute encoder	30 m, 40 m, or 50 m	JZSP-UCMP00-□□-E

* Replace the boxes (□□) in the order number with the cable length (30, 40, or 50).

Note: Flexible cables are not available.

◆ Appearance

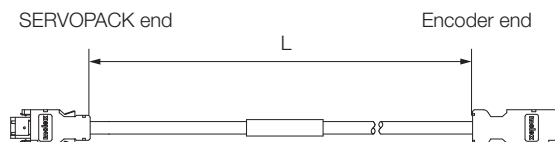

◆ Wiring Specifications

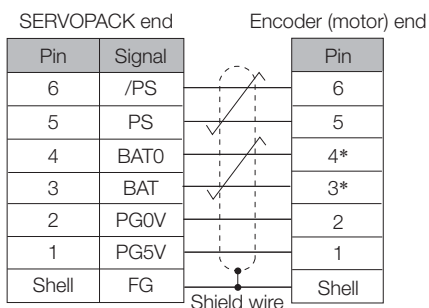

* A battery is required only for a multiturn absolute encoder.

Relay Encoder Cables with a Battery Case

◆ Selection Table

Specification	Length (L)	Order Number
For incremental or multiturn absolute encoder	0.3 m	JZSP-CSP12-E

Note: Flexible cables are not available.

◆ Appearance

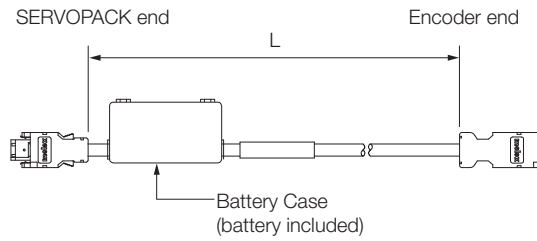

◆ Wiring Specifications

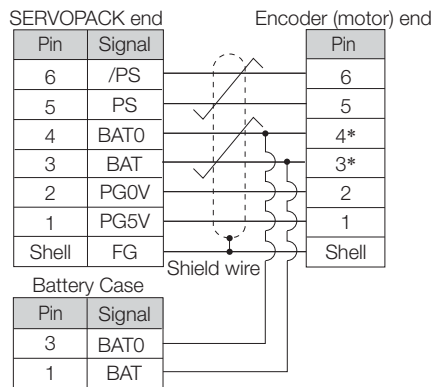

* A battery is required only for a multiturn absolute encoder.

8.5.3 SGMCV Encoder Cables

For flange specification 1, use a Motor-End Relay Encoder Cable and a SERVOPACK-End Relay Encoder Cable. For flange specification 4, use only a SERVOPACK-End Relay Encoder Cable.

If a battery is not mounted to the host controller, also obtain a Relay Encoder Cable with a Battery Case in addition to the above Cables.

NOTICE

- Install a battery at either the host controller or on the Encoder Cable.
If you install batteries both at the host controller and on the Encoder Cable at the same time, you will create a loop circuit between the batteries, resulting in a risk of damage or burning.

Motor-End Relay Encoder Cables

◆ Selection Table

Specification	Length (L)	Order Number
For single-turn or multiturn absolute encoder	0.3 m	JZSP-C7PRC0-E

Note: Flexible cables are not available.

◆ Appearance

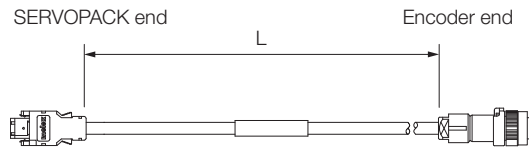

◆ Wiring Specifications

SERVOPACK end		Encoder (motor) end	
Pin	Signal	Pin	
6	/PS	2	
5	PS	1	
4	BAT0	5*	
3	BAT	8*	
2	PG0V	9	
1	PG5V	4	
Shell	FG	7	

Shield wire

* A battery is required only for a multiturn absolute encoder.

SERVOPACK-End Relay Encoder Cables

◆ Selection Table

Specification	Length (L)	Order Number*
For single-turn or multiturn absolute encoder	30 m, 40 m, or 50 m	JZSP-UCMP00-□□-E

* Replace the boxes (□□) in the order number with the cable length (30, 40, or 50).

Note: Flexible cables are not available.

◆ Appearance

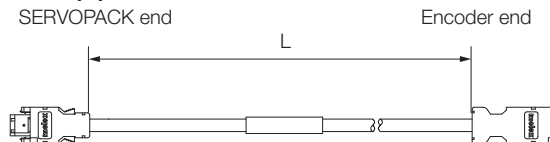

◆ Wiring Specifications

SERVOPACK end		Encoder (motor) end	
Pin	Signal		Pin
6	/PS		6
5	PS		5
4	BAT0		4*
3	BAT		3*
2	PG0V		2
1	PG5V		1
Shell	FG	Shield wire	Shell

* A battery is required only for a multiturn absolute encoder.

Relay Encoder Cables with a Battery Case

◆ Selection Table

Specification	Length (L)	Order Number
For multiturn absolute encoder	0.3 m	JZSP-CSP12-E

Note: Flexible cables are not available.

◆ Appearance

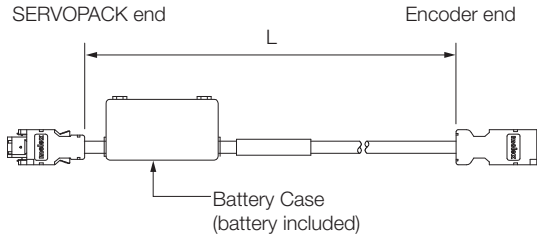

◆ Wiring Specifications

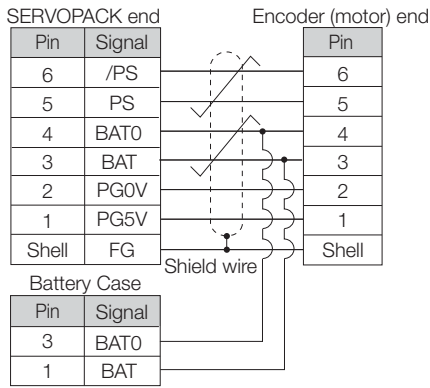

8.5.4 SGMCS Encoder Cables

You can use the cables in the following table for either SGMCS 20-bit absolute encoders (without multiturn data) or 20-bit incremental encoders.

Selection Table

Servomotor Model	Flange Specification Code (6th Digit in the Model Number)	Flange Specification	Relay Encoder Cable Order Number ^{*1, *2}	
			JZSP-CSP15-E	JZSP-UCMP00-□□-E
SGMCS-□□B SGMCS-□□C SGMCS-□□D SGMCS-□□E SGMCS-□□M SGMCS-□□N	1 or 3	Non-load side installation	Required.	Required.
		Load side installation		
	4	Non-load side installation (with cable on side)	Not required.	Required.

*1. Replace the boxes (□□) in the order number with the cable length (30, 40, or 50).

*2. Flexible cables are not available.

Motor-End Relay Encoder Cables

◆ Selection Table

Specification	Length (L)	Order Number
For incremental or absolute encoder	0.3 m	JZSP-CSP15-E

◆ Appearance



◆ Wiring Specifications

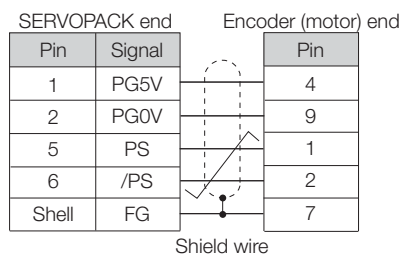

SERVOPACK-End Relay Encoder Cables

◆ Selection Table

Specification	Length (L)	Order Number*
For incremental or absolute encoder	30 m, 40 m, and 50 m	JZSP-UCMP00-□□-E

* Replace the boxes (□□) in the order number with the cable length (30, 40, or 50).

◆ Appearance

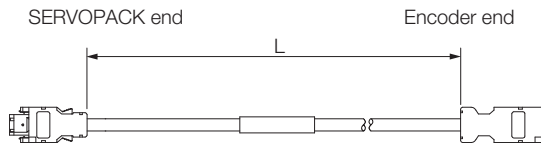

◆ Wiring Specifications

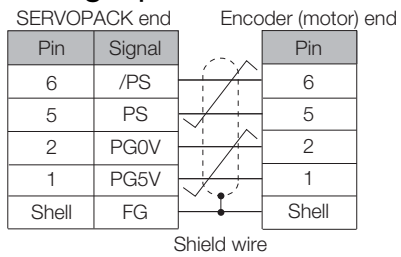

8.6

User-Assembled Wiring Materials for Encoder Cables

8.6.1 SERVOPACK Connector Kits

Type	Standard Connector Kit	Compatible Connector Kit
Inquires	Yaskawa representative	3M Japan Limited
Manufacturer	Molex Incorporated	
Order Number	JZSP-CMP9-1-E	
Specifications	55100-0670 (soldered) Product specifications: PS-54280	
External Dimensions [mm]		

Note: Cables are not included. Purchase them separately.

8.6.2 Encoder Connector Kits

Flange Specification 1 or 3

Manufacturer	Japan Aviation Electronics Industry, Ltd.	
Order Number	Straight Plug	JN1DS10SL1 (crimped)
	Socket Contacts	JN1-22-22S-PKG100
Applicable Wire Sizes	AWG21 to AWG25	
Applicable Cable Diameter	5.7 mm to 7.3 mm	
Outer Diameter of Insulating Sheath	0.8 mm to 1.5 mm	
Crimping Tool	Hand Tool	CT150-2-JN
External Dimensions [mm]		

Note: The tool is not provided by Yaskawa.

Flange Specification 4 or 5

Manufacturer	Molex Incorporated	
Order Number	JZSP-CMP9-2-E	
Specifications	54280-0609 (soldered) Product specifications: PS-54280	
External Dimensions [mm]		

8.6.3 Cables without Connectors

Encoder Cables of 20 m or Less

Item	Standard Cable	Flexible Cable
Order Number*	JZSP-CMP09-□□-E	JZSP-CSP39-□□-E
Specifications	UL20276 (rated temperature: 80°C) AWG22 × 2C + AWG24 × 2P	UL20276 (rated temperature: 80°C) AWG22 × 2C + AWG24 × 2P
	AWG22 (0.33 mm ²) Outer diameter of insulating sheath: 1.15 mm	AWG22 (0.33 mm ²) Outer diameter of insulating sheath: 1.35 mm
	AWG24 (0.20 mm ²) Outer diameter of insulating sheath: 1.09 mm	AWG24 (0.20 mm ²) Outer diameter of insulating sheath: 1.21 mm
Finished Diameter	6.5 mm	6.8 mm
Internal Structure and Lead Colors		

* Replace the boxes (□□) in the order number with the cable length (05, 10, 15, or 20).

Relay Encoder Cable of 30 m to 50 m

Item	Standard Cable
Order Number*	JZSP-CMP19-□□-E
Specifications	UL20276 (rated temperature: 80°C) AWG16 × 2C + AWG26 × 2P
	AWG16 (1.31 mm ²) Outer diameter of insulating sheath: 2.0 mm
	AWG26 (0.13 mm ²) Outer diameter of insulating sheath: 0.91 mm
Finished Diameter	6.8 mm
Internal Structure and Lead Colors	

* Replace the boxes (□□) in the order number with the cable length (30, 40, or 50).

8.7 Wiring Precautions

The wiring precautions are the same as for SGM7M Rotary Servomotors. Refer to the following section.

 2.5 *Wiring Precautions* on page 2-9

Cables and User-Assembled Wiring Materials for Linear Servomotors

9

9.1 Recommended Linear Encoders 9-3

- 9.1.1 Incremental Linear Encoders 9-3
- 9.1.2 Absolute Linear Encoders 9-4

9.2 Cable Configurations 9-6

- 9.2.1 Connections to Linear Encoder from Dr. JOHANNES HEIDENHAIN GmbH 9-6
- 9.2.2 Connections to Linear Encoder from RSF Elektronik GmbH 9-10
- 9.2.3 Connections to Linear Encoder from Renishaw plc 9-11
- 9.2.4 Connections to Linear Encoder from RLS d.o.o. 9-14
- 9.2.5 Connections to Linear Encoder from Magnescale Co., Ltd. 9-15
- 9.2.6 Connections to Linear Encoders from Mitutoyo Corporation 9-22
- 9.2.7 Connections to Linear Encoder from Fagor Automation S. Coop. 9-23
- 9.2.8 Connections to Linear Encoder from Canon Precision Inc. 9-24

9.3 Cable Selection Table 9-25

- 9.3.1 Servomotor Main Circuit Cables 9-25
- 9.3.2 Linear Encoder Cables 9-26
- 9.3.3 Serial Converter Unit Cables 9-26
- 9.3.4 Sensor Cables 9-27
- 9.3.5 Encoder Cables 9-27
- 9.3.6 Cable Dimensional Drawings and Wiring Specifications 9-28
- 9.3.7 Wiring Precautions 9-35

9.4	Serial Converter Unit	9-37
9.4.1	Selection Table	9-37
9.4.2	Characteristics and Specifications	9-38
9.4.3	External Dimensions	9-39
9.4.4	Analog Signal Input Timing	9-43

9.1

Recommended Linear Encoders

9.1.1 Incremental Linear Encoders

Output Signal	Manufacturer	Linear Encoder Type	Model			Linear Encoder Pitch [μm]	Resolution [nm]	Maximum Speed* ₃ [m/s]	Support for Polarity Sensor Input	Application to Linear Servomotors	Application to Fully-Closed Loop Control
			Scale	Sensor Head	Relay Device between SERVOPACK and Linear Encoder						
1 Vp-p Analog Voltage* ₁	Dr. JOHANNES HEIDENHAIN GmbH	Exposed	LIDA48□		JZDP-H003/-H006* ₅	20	78.1	5	✓	✓	✓
					JZDP-J003/-J006* ₅		4.9	2	✓	✓	* ₈
			LIF48□		JZDP-H003/-H006* ₅	4	15.6	1	✓	✓	✓
					JZDP-J003/-J006* ₅		1.0	0.4	✓	* ₈	* ₈
	Renishaw plc* ₄	Exposed	RGS20	RGH22B	JZDP-H005/-H008* ₅	20	78.1	5	✓	✓	✓
					JZDP-J005/-J008* ₅		4.9	2	✓	✓	* ₈
			TONIC series (Ti0000A00V only)		JZDP-H005/-H008* ₅	20	78.1	5	✓	✓	✓
					JZDP-J005/-J008* ₅		4.9	2	✓	✓	* ₈
Encoder for Yaskawa's Serial Interface* ₂	Magnescale Co., Ltd.	Exposed	SL7□0	PL101-RY* ₆		800	97.7	10	–	✓	✓
				PL101	MJ620-T13* ₇				✓	✓	* ₈
			SQ10	PQ10	MQ10-FLA				400	48.83	3
		MQ10-GLA			✓	✓	–				
		Sealed	SR75-□□□□□LF	–	80	9.8	3.33	–	✓	✓	
			SR75-□□□□□MF	–	80	78.1	3.33	–	✓	✓	
	SR85-□□□□□LF		–	80	9.8	3.33	–	✓	✓		
	SR85-□□□□□MF		–	80	78.1	3.33	–	✓	✓		
	Canon Precision Inc.	Exposed	PS90-20160 glass	PH03-36110	–	128	62.5	12.8	–	✓	✓
			PS04-30110 SUS	PH03-36120	–	128	62.5	12.8	–	✓	✓

✓: Applicable

*1. You must also use a Yaskawa Serial Converter Unit. The output signal will be multiplied by 8 bits (256 divisions) or 12 bits (4,096 divisions) in the Serial Converter Unit.

*2. The multiplier (number of divisions) depends on the Linear Encoder. Also, you must write the Servomotor constant file to the Linear Encoder in advance.

*3. The maximum speeds given in the above table are the maximum applicable speeds of the encoders when combined with a Yaskawa SERVOPACK. The actual speed will be restricted by either the maximum speed of the Linear Servomotor or the maximum speed of the Linear Encoder (given above).

*4. If you use the origin signals with a Linear Encoder from Renishaw plc, the origin may sometimes be falsely detected. If that occurs, use the BID/DIR signal to output the origin signal only in one direction.

*5. These are the models of Serial Converter Units.

*6. This is the model of the Sensor Head with Interpolator.

*7. This is the model of the Interpolator.

*8. Contact your Yaskawa representative.

Note: Confirm detailed specifications, such as the tolerances, dimensions, and operating environment, with the manufacturer of the Linear Encoder before you use it.

9.1.2 Absolute Linear Encoders

Output Signal	Manufacturer	Linear Encoder Type	Model			Linear Encoder Pitch* ¹ [μm]	Resolution [nm]	Maximum Speed* ² [m/s]	Support for Polarity Sensor Input	Application to Linear Servo-motors	Application to Fully-Closed Loop Control
			Scale	Sensor Head	Relay Device between SERVOPACK and Linear Encoder						
Encoder for Yaskawa's Serial Interface* ³	Magnescale Co., Ltd.	Exposed	SQ47- □□□□SF□□□	-	-	20.48	5	3.33	-	✓	✓
			SQ47- □□□□TF□□□								
			SQ47- □□□□AF□□□	-	-	40.96	10	3.33	-	✓	✓
			SQ47- □□□□FF□□□								
			SQ57- □□□□SF□□□	-	-	20.48	5	3.33	-	✓	✓
			SQ57- □□□□TF□□□								
			SQ57- □□□□AF□□□	-	-	40.96	10	3.33	-	✓	✓
			SQ57- □□□□FF□□□								
		Sealed	SR77-□□□□LF	-	-	80	9.8	3.33	-	✓	✓
			SR77-□□□□MF	-	-	80	78.1	3.33	-	✓	✓
			SR87-□□□□LF	-	-	80	9.8	3.33	-	✓	✓
			SR87-□□□□MF	-	-	80	78.1	3.33	-	✓	✓
	Mitutoyo Corporation	Exposed	ST781A	-	-	256	500	5	-	✓	✓
			ST782A	-	-	256	500	5	-	✓	✓
			ST783A	-	-	51.2	100	5	-	✓	✓
			ST784A	-	-	51.2	100	5	-	✓	✓
			ST788A	-	-	51.2	100	5	-	✓	✓
			ST789A* ⁴	-	-	25.6	50	5	-	✓	✓
			ST1381	-	-	5.12	10	8	-	✓	✓
			ST1382	-	-	0.512	1	3.6* ⁵	-	✓	✓
			AT1383A	-	-	25.6	50	3	-	✓	✓
			AT1384A	-	-	5.12	10	3	-	✓	✓
	AT1387A	-	-	0.512	1	3	-	✓	✓		
	Dr. JOHANNES HEIDENHAIN GmbH	Exposed	LIC4100 Series* ⁶	EIB3391Y	20.48	5	10	-	✓	✓	
			LIC2100 Series* ⁶	EIB3391Y	204.8	50	10	-	✓	✓	
				EIB3391Y	409.6	100	10	-	✓	✓	
			LIC4190 Series	-	40.96	10	10	-	✓	✓	
				-	20.48	5	10	-	✓	✓	
				-	4.096	1	10	-	✓	✓	
		-		40.96	10	10	-	✓	✓		
		LIC3190 Series	-	40.96	10	10	-	✓	✓		
		LIC2190 Series	-	409.6	100	10	-	✓	✓		
-			204.8	50	10	-	✓	✓			
Sealed	LC115	EIB3391Y	40.96	10	3	-	✓	✓			
	LC415	EIB3391Y	40.96	10	3	-	✓	✓			
RSF Elektronik GmbH	Exposed	MC15Y Series	-	409.6	100	10	-	✓	✓		
			-	204.8	50	10	-	✓	✓		

Continued on next page.

Continued from previous page.

Output Signal	Manufacturer	Linear Encoder Type	Model			Linear Encoder Pitch* ¹ [μm]	Resolution [nm]	Maximum Speed* ² [m/s]	Support for Polarity Sensor Input	Application to Linear Servomotors	Application to Fully-Closed Loop Control
			Scale	Sensor Head	Relay Device between SERVOPACK and Linear Encoder						
Encoder for Yaskawa's Serial Interface* ³	Renishaw plc	Exposed	EL36Y□□050F□□□		–	12.8	50	100	–	✓	✓
			EL36Y□□100F□□□		–	25.6	100	100	–	✓	✓
			EL36Y□□500F□□□		–	128	500	100	–	✓	✓
			RL36Y□□050□□□		–	12.8	50	100	–	✓	✓
			RL36Y□□001□□□		–	0.256	1	3.6	–	✓	✓
			FN10□□□□□□□□ 36YX001□		–	0.256	1	3.6	–	✓	✓
			FN10□□□□□□□□ 36YX010□		–	2.56	10	4	–	✓	✓
			FN10□□□□□□□□ 36YX050□		–	12.8	50	4	–	✓	✓
	RLS d.o.o.	Exposed	LA11YA Series		–	2,000	976.5	7.00	–	✓	✓
					–	2,000	488.2	3.65	–	✓	✓
					–	2,000	244.1	1.82	–	✓	✓
	Fagor Automation S. Coop.	Exposed	L2AK208		–	20	78.1	8.0	–	✓	✓
					L2AK211		–	20	9.8	8.0	–
		Sealed	LAK209		–	40	78.1	3.0	–	✓	✓
			LAK212		–	40	9.8	3.0	–	✓	✓
			S2AK208		–	20	78.1	3.0	–	✓	✓
			SV2AK208		–	20	78.1	3.0	–	✓	✓
			G2AK208		–	20	78.1	3.0	–	✓	✓
			S2AK211		–	20	9.8	3.0	–	✓	✓
			SV2AK211		–	20	9.8	3.0	–	✓	✓
G2AK211		–	20	9.8	3.0	–	✓	✓			
Canon Precision Inc.	Exposed	PS90-20160 glass	PH03-36E00	–	128	62.5	12.8	–	✓	✓	

✓: Applicable

*1. These are reference values for setting SERVOPACK parameters. Contact the manufacturer for actual linear encoder scale pitches.

*2. The maximum speeds given in the above table are the maximum applicable speeds of the encoders when combined with a Yaskawa SERVOPACK. The actual speed will be restricted by either the maximum speed of the Linear Servomotor or the maximum speed of the Linear Encoder (given above).

*3. The multiplier (number of divisions) depends on the Linear Encoder. Also, you must write the Servomotor constant file to the Linear Encoder in advance.

*4. Contact Mitutoyo Corporation for details on the Linear Encoders.

*5. The speed is restricted for some SERVOPACKs.

*6. Sales of the interface unit EIB3391Y with the LIC4100 and LIC2100 series have ended due to the release of the LIC4190, LIC3190, and LIC2190 series.

Note: Confirm detailed specifications, such as the tolerances, dimensions, and operating environment, with the manufacturer of the Linear Encoder before you use it.

9.2 Cable Configurations

9.2.1 Connections to Linear Encoder from Dr. JOHANNES HEIDENHAIN GmbH

Connections for a 1 Vp-p Analog Voltage Output Signal

You must make the connections through a Yaskawa Serial Converter Unit. The output signal will be multiplied by 8 bits (256 divisions) or 12 bits (4,096 divisions) in the Serial Converter Unit.

◆ Connecting to a Linear Servomotor with a Polarity Sensor

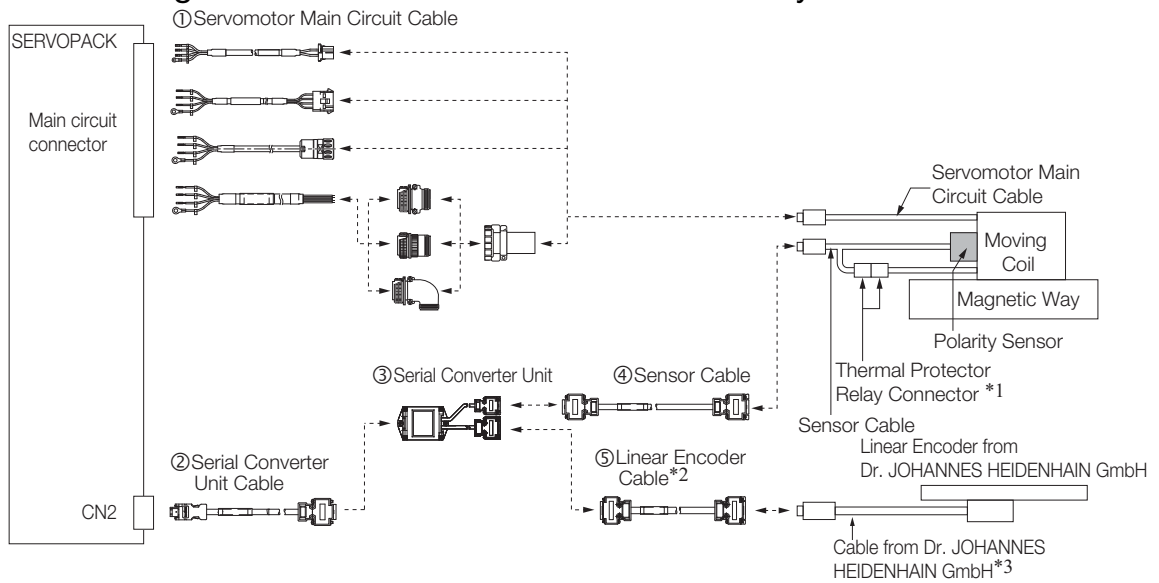

- *1. Only SGLFW2 Servomotors come equipped with Thermal Protector Relay Connectors.
- *2. When using a JZDP-J00□-□□□ Serial Converter Unit, do not use a Yaskawa Linear Encoder Cable that is longer than 3 m.
- *3. Contact Dr. JOHANNES HEIDENHAIN GmbH for details on cables (analog 1 Vp-p output, D-sub 15-pin, male) from Dr. JOHANNES HEIDENHAIN GmbH.

No.	Cable Type	Reference
①	Servomotor Main Circuit Cable	page 9-25
②	Serial Converter Unit Cable	page 9-26
③	Serial Converter Unit	page 9-37
④	Sensor Cable	page 9-27
⑤	Linear Encoder Cable	page 9-26

◆ Connecting to a Linear Servomotor without a Polarity Sensor

■ Servomotors Other Than the SGLFW2

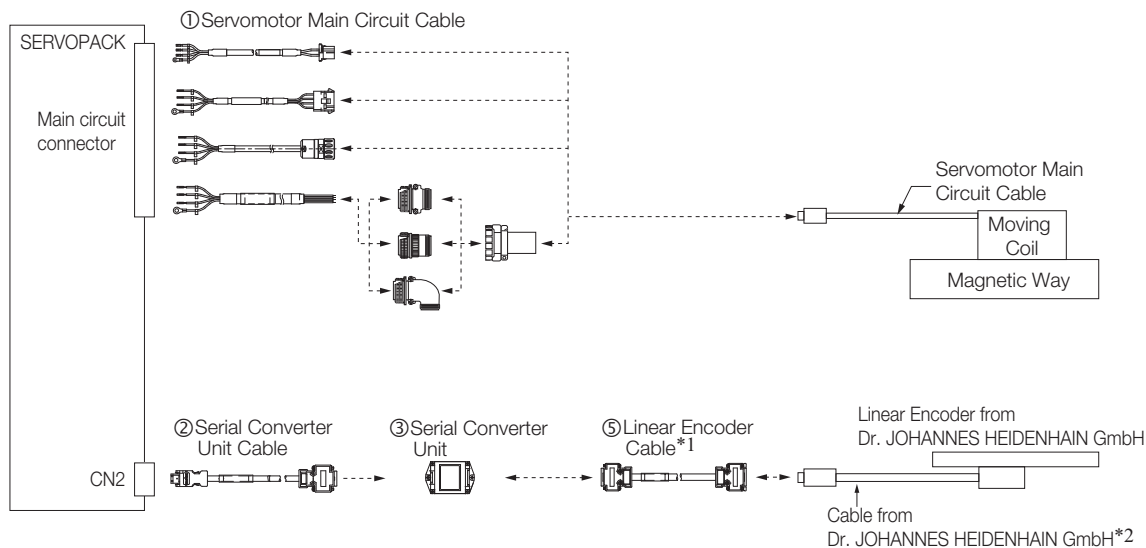

*1. When using a JZDP-J00□-□□□ Serial Converter Unit, do not use a Yaskawa Linear Encoder Cable that is longer than 3 m.

*2. Contact Dr. JOHANNES HEIDENHAIN GmbH for details on cables (analog 1 Vp-p output, D-sub 15-pin, male) from Dr. JOHANNES HEIDENHAIN GmbH.

■ SGLFW2 Servomotors

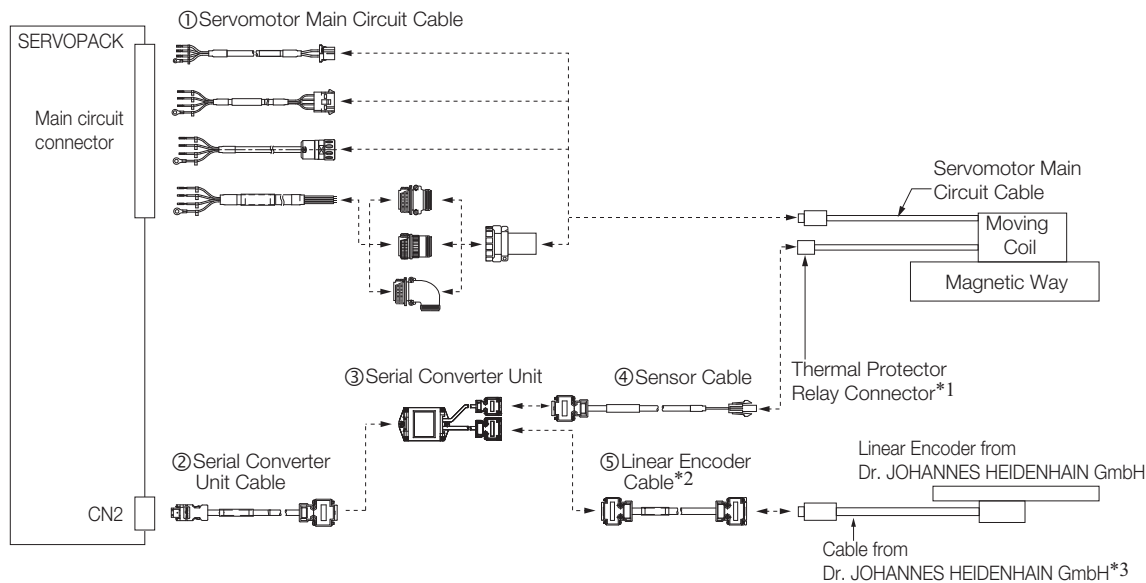

*1. Only SGLFW2 Servomotors come equipped with Thermal Protector Relay Connectors.

*2. When using a JZDP-J00□-□□□ Serial Converter Unit, do not use a Yaskawa Linear Encoder Cable that is longer than 3 m.

*3. Contact Dr. JOHANNES HEIDENHAIN GmbH for details on cables (analog 1 Vp-p output, D-sub 15-pin, male) from Dr. JOHANNES HEIDENHAIN GmbH.

No.	Cable Type	Reference
①	Servomotor Main Circuit Cable	page 9-25
②	Serial Converter Unit Cable	page 9-26
③	Serial Converter Unit	page 9-37
④	Sensor Cable	page 9-27
⑤	Linear Encoder Cable	page 9-26

LIC4100, LIC2100, LC115, or LC415 Linear Encoder with EIB3391Y Interface Unit



Important

1. You cannot use an LIC4100, LIC2100, LC115, or LC415 Linear Encoder with a Linear Servomotor with a Polarity Sensor.
2. If you use an SGLFW2 Servomotor, input the thermal protector signal from the Linear Servomotor to the host controller. The thermal protector signal is closed when the temperature is normal and open when the thermal protector is activated. Do not exceed 3 A or 30 V.

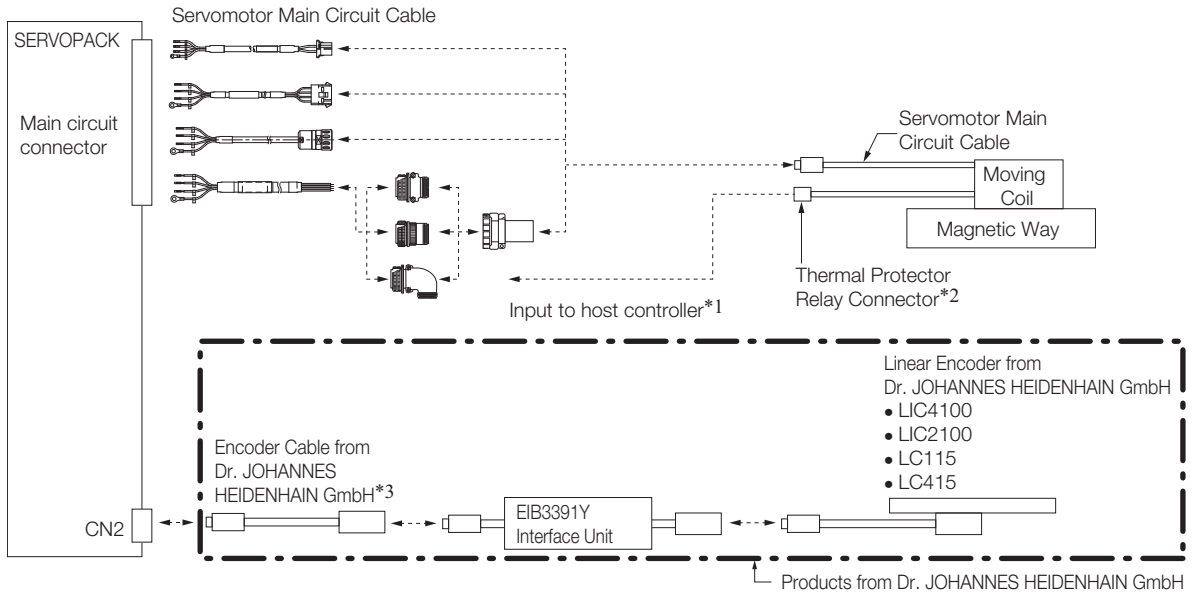

*1. Cables to connect to the host controller are not provided by Yaskawa. Refer to the following section for information on connector models.

 **JZSP-CL2TH00-□□-E Sensor Cables** on page 9-35

*2. Only SGLFW2 Servomotors come equipped with Thermal Protector Relay Connectors.

*3. Use an Encoder Cable from Dr. JOHANNES HEIDENHAIN GmbH. Contact Dr. JOHANNES HEIDENHAIN GmbH for detailed Encoder Cable specifications.

LIC4190, LIC3190, or LIC2190 Linear Encoder



1. You cannot use an LIC4190, LIC3190, or LIC2190 Linear Encoder together with a Linear Servomotor with a Polarity Sensor.
2. If you use an SGLFW2 Servomotor, input the thermal protector signal from the Linear Servomotor to the host controller. The thermal protector signal is closed when the temperature is normal and open when the thermal protector is activated. Do not exceed 3 A or 30 V.

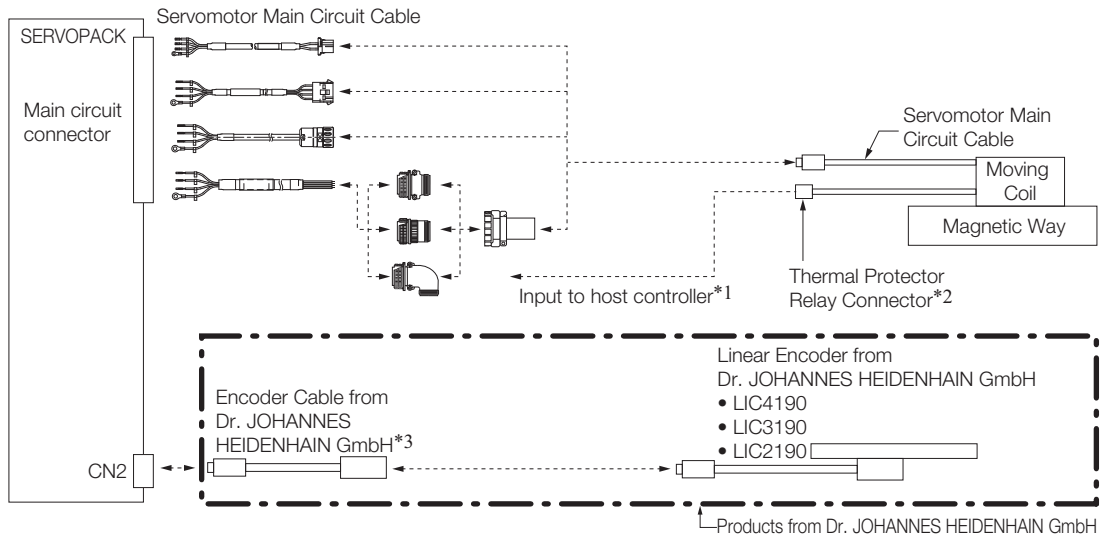

*1. Cables to connect to the host controller are not provided by Yaskawa.

Refer to the following section for information on connector models.

JZSP-CL2TH00-□□-E Sensor Cables on page 9-35

*2. Only SGLFW2 Servomotors come equipped with Thermal Protector Relay Connectors.

*3. Use an Encoder Cable from Dr. JOHANNES HEIDENHAIN GmbH. Contact Dr. JOHANNES HEIDENHAIN GmbH for detailed Encoder Cable specifications.

9.2.2 Connections to Linear Encoder from RSF Elektronik GmbH



1. You cannot use a Linear Encoder from RSF Elektronik GmbH together with a Linear Servomotor with a Polarity Sensor.
2. If you use an SGLFW2 Servomotor, input the thermal protector signal from the Linear Servomotor to the host controller. The thermal protector signal is closed when the temperature is normal and open when the thermal protector is activated. Do not exceed 3 A or 30 V.

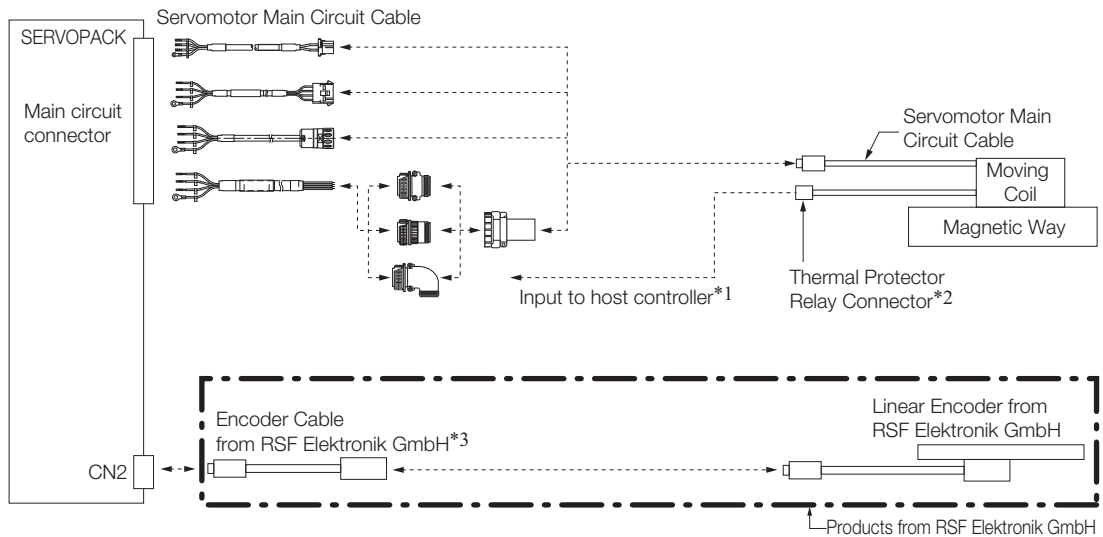

*1. Cables to connect to the host controller are not provided by Yaskawa. Refer to the following section for information on connector models.
 **JZSP-CL2TH00-□□-E Sensor Cables** on page 9-35

*2. Only SGLFW2 Servomotors come equipped with Thermal Protector Relay Connectors.

*3. Use an Encoder Cable from RSF Elektronik GmbH. Contact Dr. JOHANNES HEIDENHAIN GmbH for detailed Encoder Cable specifications.

9.2.3 Connections to Linear Encoder from Renishaw plc

Connections for a 1 Vp-p Analog Voltage Output Signal

You must make the connections through a Yaskawa Serial Converter Unit. The output signal will be multiplied by 8 bits (256 divisions) or 12 bits (4,096 divisions) in the Serial Converter Unit.

◆ Connecting to a Linear Servomotor with a Polarity Sensor

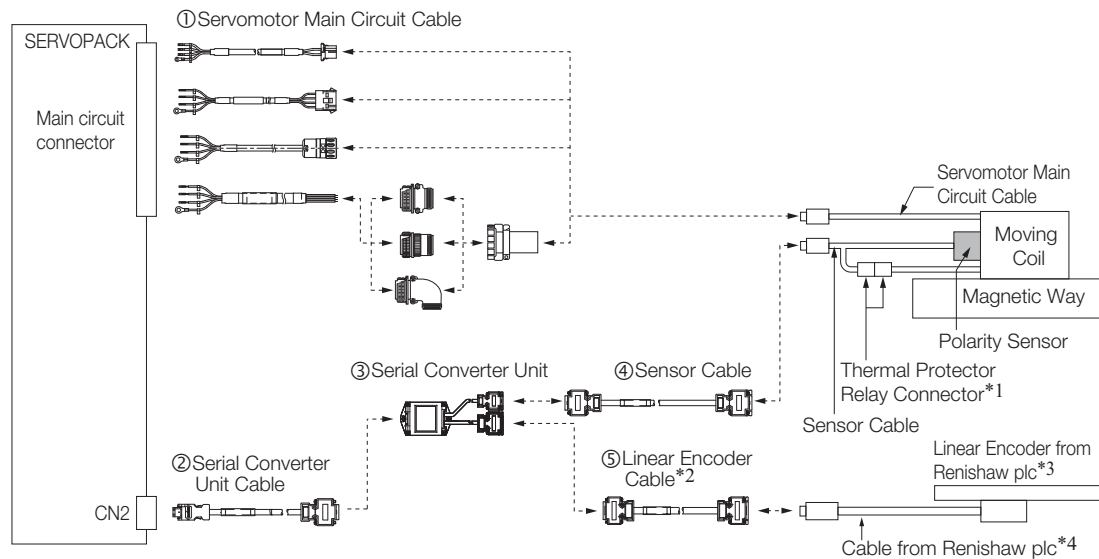

*1. Only SGLFW2 Servomotors come equipped with Thermal Protector Relay Connectors.

*2. When using a JZDP-J00□-□□□ Serial Converter Unit, do not use a Yaskawa Linear Encoder Cable that is longer than 3 m.

*3. If you use the origin signals with a Linear Encoder from Renishaw plc, the origin may sometimes be falsely detected.

If that occurs, use the BID/DIR signal to output the origin signal only in one direction.

*4. Contact Renishaw plc for details on cables (analog 1 Vp-p output, D-sub 15-pin, male) from Renishaw plc. However, the BID and DIR signals are not connected.

No.	Cable Type	Reference
①	Servomotor Main Circuit Cable	page 9-25
②	Serial Converter Unit Cable	page 9-26
③	Serial Converter Unit	page 9-37
④	Sensor Cable	page 9-27
⑤	Linear Encoder Cable	page 9-26

◆ Connecting to a Linear Servomotor without a Polarity Sensor

■ Servomotors Other Than the SGLFW2

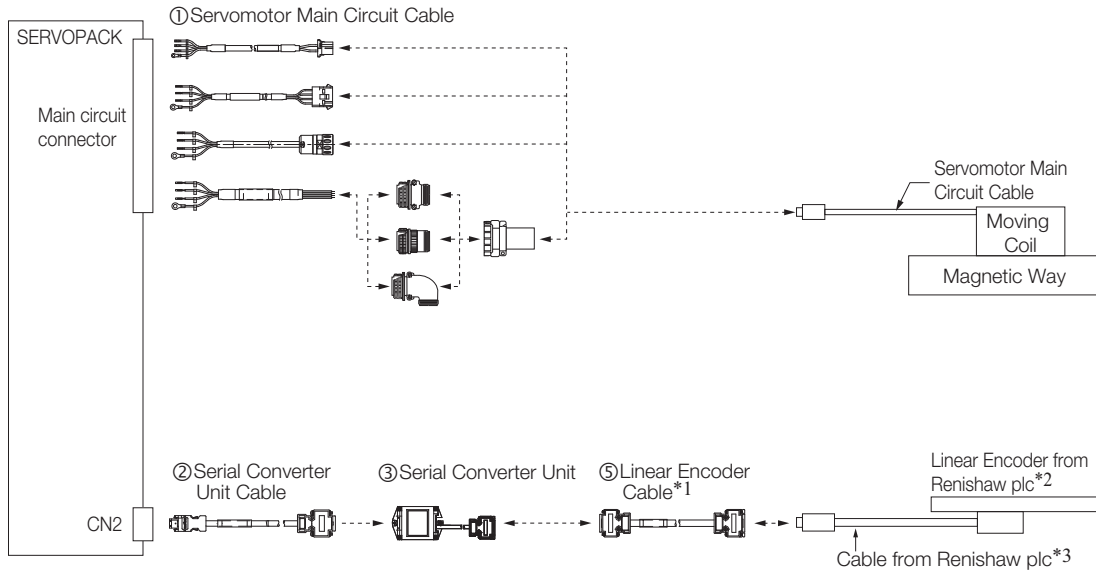

- *1. When using a JZDP-J00□-□□□ Serial Converter Unit, do not use a Yaskawa Linear Encoder Cable that is longer than 3 m.
- *2. If you use the origin signals with a Linear Encoder from Renishaw plc, the origin may sometimes be falsely detected. If that occurs, use the BID/DIR signal to output the origin signal only in one direction.
- *3. Contact Renishaw plc for details on cables (analog 1 Vp-p output, D-sub 15-pin, male) from Renishaw plc. However, the BID and DIR signals are not connected.

■ SGLFW2 Servomotors

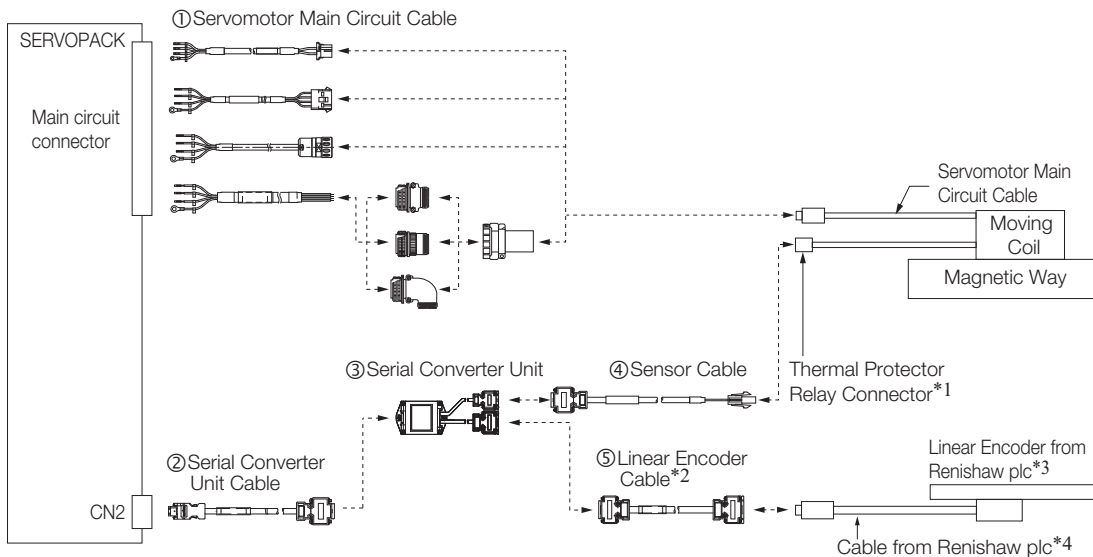

- *1. Only SGLFW2 Servomotors come equipped with Thermal Protector Relay Connectors.
- *2. When using a JZDP-J00□-□□□ Serial Converter Unit, do not use a Yaskawa Linear Encoder Cable that is longer than 3 m.
- *3. If you use the origin signals with a Linear Encoder from Renishaw plc, the origin may sometimes be falsely detected. If that occurs, use the BID/DIR signal to output the origin signal only in one direction.
- *4. Contact Renishaw plc for details on cables (analog 1 Vp-p output, D-sub 15-pin, male) from Renishaw plc. However, the BID and DIR signals are not connected.

No.	Cable Type	Reference
①	Servomotor Main Circuit Cable	page 9-25
②	Serial Converter Unit Cable	page 9-26
③	Serial Converter Unit	page 9-37
④	Sensor Cable	page 9-27
⑤	Linear Encoder Cable	page 9-26

EVOLUTE-Series, RESOLUTE-Series, and FORTiS-Series Linear Encoder



1. You cannot use an EVOLUTE-Series, RESOLUTE-Series or FORTiS-Series Linear Encoder together with a Linear Servomotor with a Polarity Sensor.
2. If you use an SGLFW2 Servomotor, input the thermal protector signal from the Linear Servomotor to the host controller. The thermal protector signal is closed when the temperature is normal and open when the thermal protector is activated. Do not exceed 3 A or 30 V.

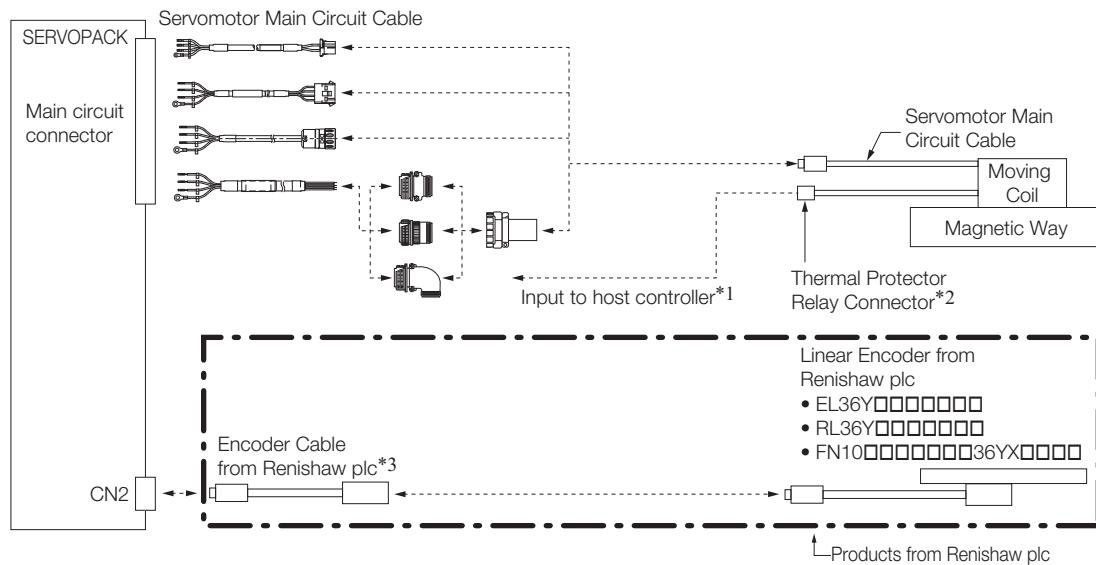

*1. Cables to connect to the host controller are not provided by Yaskawa.

Refer to the following section for information on connector models.

 **JZSP-CL2TH00-□□-E Sensor Cables** on page 9-35

*2. Only SGLFW2 Servomotors come equipped with Thermal Protector Relay Connectors.

*3. Use an Encoder Cable from Renishaw plc. Contact Renishaw plc for detailed Encoder Cable specifications.

9.2.4 Connections to Linear Encoder from RLS d.o.o.



Important

1. You cannot use a Linear Encoder from RLS d.o.o. together with a Linear Servomotor with a Polarity Sensor.
2. If you use an SGLFW2 Servomotor, input the thermal protector signal from the Linear Servomotor to the host controller. The thermal protector signal is closed when the temperature is normal and open when the thermal protector is activated. Do not exceed 3 A or 30 V.

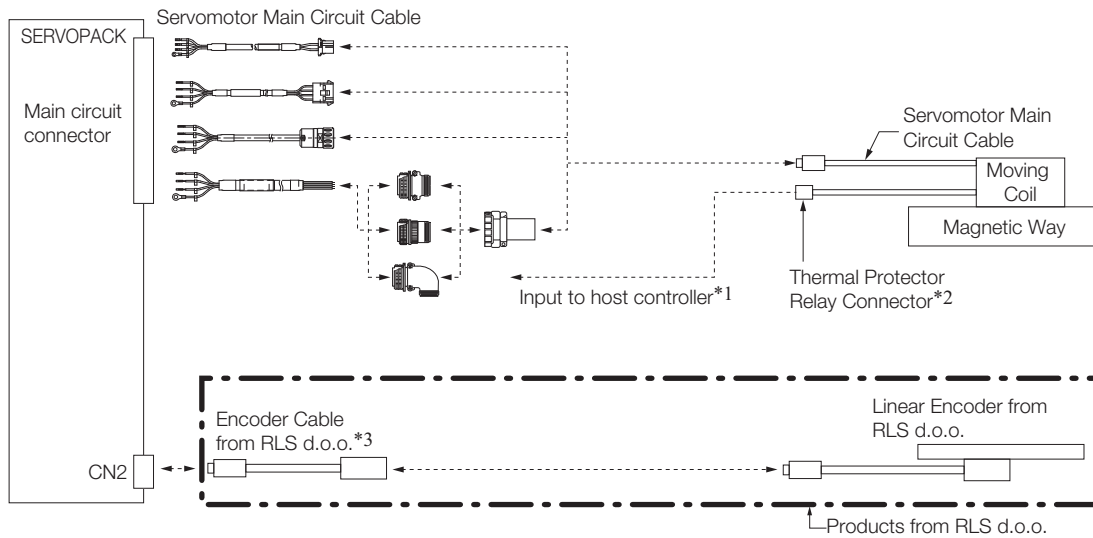

*1. Cables to connect to the host controller are not provided by Yaskawa. Refer to the following section for information on connector models.

 *JZSP-CL2TH00-□□-E Sensor Cables* on page 9-35

*2. Only SGLFW2 Servomotors come equipped with Thermal Protector Relay Connectors.

*3. Use an Encoder Cable from RLS d.o.o. Contact RLS d.o.o. or Renishaw plc for detailed Encoder Cable specifications.

9.2.5 Connections to Linear Encoder from Magnescale Co., Ltd.

SL7□0 Linear Encoder and PL101-RY Sensor Head with Interpolator



1. You cannot use a PL101-RY Sensor Head with an Interpolator together with a Linear Servomotor with a Polarity Sensor.
2. If you use an SGLFW2 Servomotor, input the thermal protector signal from the Linear Servomotor to the host controller. The thermal protector signal is closed when the temperature is normal and open when the thermal protector is activated. Do not exceed 3 A or 30 V.

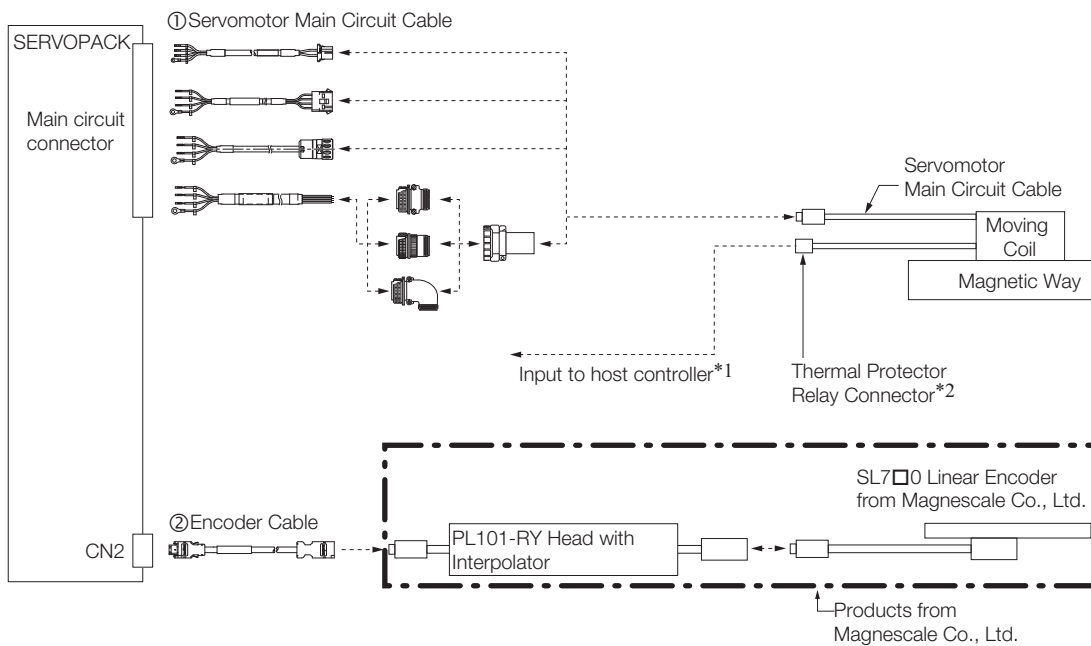

*1. Cables to connect to the host controller are not provided by Yaskawa. Refer to the following section for information on connector models.

JZSP-CL2TH00-□□-E Sensor Cables on page 9-35

*2. Only SGLFW2 Servomotors come equipped with Thermal Protector Relay Connectors.

No.	Cable Type	Reference
①	Servomotor Main Circuit Cables	page 9-25
②	Encoder Cable	page 9-27

SL7□0 Linear Encoder, PL101 Sensor Head, and MJ620-T13 Interpolator



Important

1. A 5-VDC power supply is required for the MJ620-T13. (The 5-VDC power supply is not provided by Yaskawa.)
2. Refer to the MJ620-T13 specifications from Magnescale Co., Ltd. for the current consumption of the MJ620-T13.
3. If you use an SGLFW2 Servomotor, remove the thermal protector relay connector and input the thermal protector signal from the Linear Servomotor to the host controller. The thermal protector signal is closed when the temperature is normal and open when the thermal protector is activated. Do not exceed 3 A or 30 V.

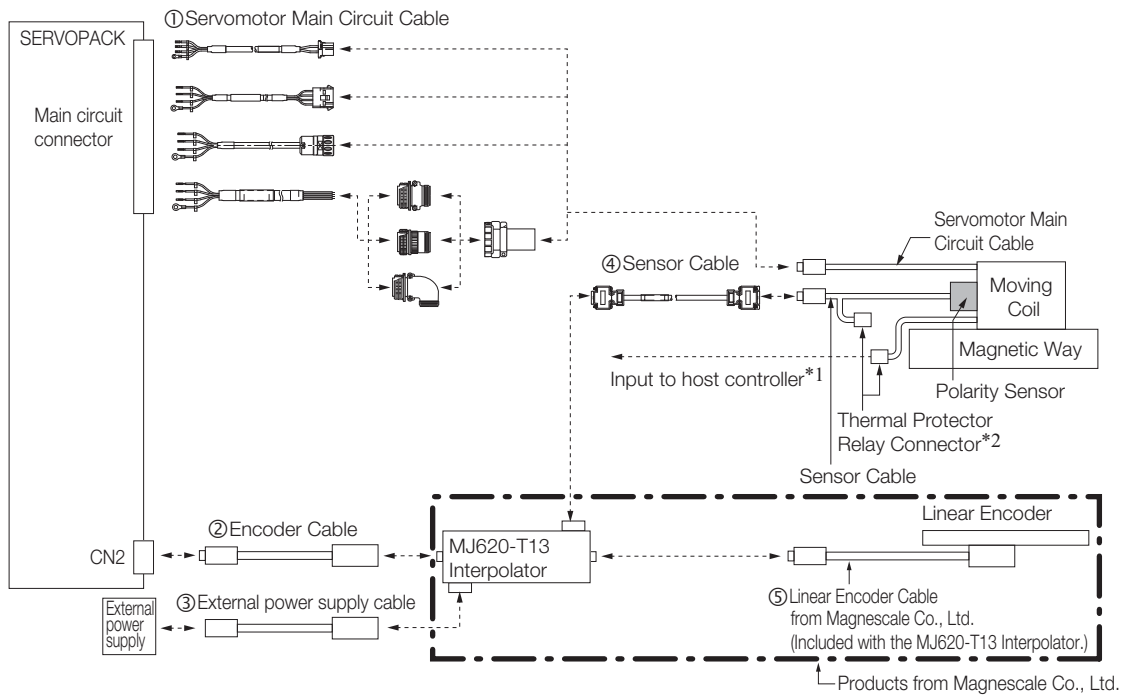

*1. Cables to connect to the host controller are not provided by Yaskawa. Refer to the following section for information on connector models.

 **JZSP-CL2TH00-□□-E Sensor Cables** on page 9-35

*2. Only SGLFW2 Servomotors come equipped with Thermal Protector Relay Connectors.

No.	Cable Type	Reference
①	Servomotor Main Circuit Cable	page 9-25
②	Encoder Cable*	These cables are not provided by Yaskawa.
③	External power supply cable	
④	Sensor Cable	page 9-27
⑤	Linear Encoder Cable	Use the cables that come with the MJ620-T13 Interpolator. For details, refer to the specifications for the MJ620-T13 Interpolator.

* When you fabricate the Encoder Cable, always connect the shield wire from the Encoder Cable to the connector (shell). There is a risk of failure or malfunction.

◆ Encoder Cables

These cables are not provided by Yaskawa. Use a shielded cable. In addition, always connect the shield wire from the Encoder Cable to the connector (shell). Refer to the following tables for the pin layouts.

■ SERVOPACK End of Cable (CN2)

- Plug Connector: 55100-0670 (Molex Incorporated)
- Connector order number: JZSP-CMP9-1-E (SERVOPACK Connector Kit)

Pin	Signal	Function
1	PG5 V	Encoder power supply +5 V
2	PG0 V	Encoder power supply 0 V
3	–	–
4	–	–
5	PS	Serial data
6	/PS	
Shell	Shield	–

■ MJ620-T13 End of Cable

For details, refer to the specifications for the MJ620-T13 from Magnescale Co., Ltd..

- Receptacle: PCR-E20LMD+ (Honda Tsushin Kogyo Co., Ltd.)
- Plug: PCR-E20FS+ (Honda Tsushin Kogyo Co., Ltd.)
- Shell: PCS-E20L□ (Honda Tsushin Kogyo Co., Ltd.)

Pin	Signal	Function	Pin	Signal	Function
1	Do not connect.	–	12	0 V	0 V
2	Do not connect.	–	13	Do not connect.	–
3	Do not connect.	–	14	0 V	0 V
4	Do not connect.	–	15	Do not connect.	–
5	SD	Serial data	16	0 V	0 V
6	/SD		17	Do not connect.	–
7	Do not connect.	–	18	Do not connect.	–
8	Do not connect.	–	19	Do not connect.	–
9	Do not connect.	–	20	Do not connect.	–
10	Do not connect.	–	Shell	Shield	–
11	Do not connect.	–			

■ Cables without Connectors

Name	Length (L)	Order Number		Reference
		Standard Cable	Flexible Cable	
Cables without Connectors	5 m	JZSP-CMP09-05-E	JZSP-CSP39-05-E	page 6-26
	10 m	JZSP-CMP09-10-E	JZSP-CSP39-10-E	
	15 m	JZSP-CMP09-15-E	JZSP-CSP39-15-E	
	20 m	JZSP-CMP09-20-E	JZSP-CSP39-20-E	

Note: We recommend that you use Flexible Cables.

◆ External Power Supply Cables

This cable is not provided by Yaskawa. Refer to the table on the right for the pin layout.

Pin	Signal	Function
1	+5 V	+5 V
2	0 V	0 V

For details, refer to the specifications for the MJ620-T13 from Magnescale Co., Ltd..

- Connector Header: MC1.5/2-GF-3.81 (Phoenix Contact)
- Connector Plug: MC1.5/2-STF-3.81 (Phoenix Contact)

SmartSCALE Linear Encoder (SQ10 Scale +MQ10-□LA Interpolator)



Important If you use an SGLFW2 Servomotor, remove the thermal protector relay connector and input the thermal protector signal from the Linear Servomotor to the host controller. The thermal protector signal is closed when the temperature is normal and open when the thermal protector is activated. Do not exceed 3 A or 30 V.

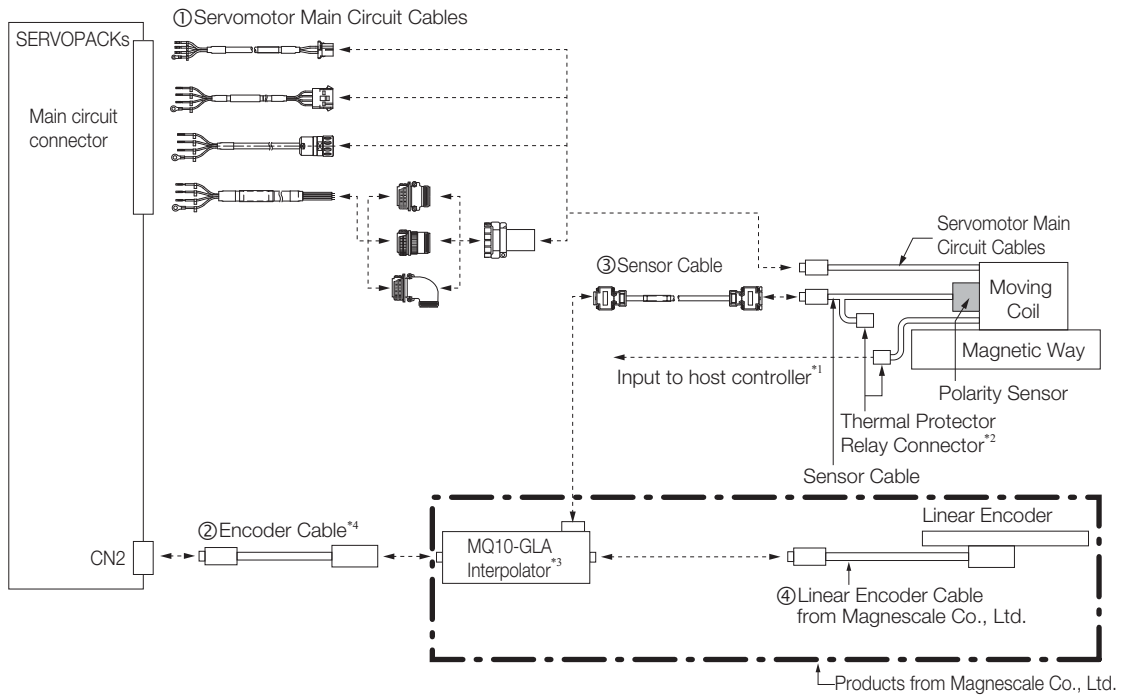

*1. Cables to connect to the host controller are not provided by Yaskawa. Refer to the following section for information on connector models.

 *JZSP-CL2TH00-□□-E Sensor Cables* on page 9-35

*2. Only SGLFW2 Servomotors come equipped with Thermal Protector Relay Connectors.

*3. The above diagram shows the connections when a MQ10-GLA Interpolator (equipped with an electromagnetic sensor input) is used.

*4. The maximum length of the Encoder Cable is 15 m.

No.	Cable Type		Reference
①	Servomotor Main Circuit Cables		page 9-25
②	Encoder Cable*	This cable is not provided by Yaskawa.	page 9-19
③	Sensor Cable		page 9-27
④	Linear Encoder Cables	Use the cables that come with the MQ10-□LA Interpolator. For details, refer to the specifications for the MQ10-□LA Interpolator.	-

* When you fabricate the Encoder Cable, always connect the shield wire from the Encoder Cable to the connector (shell). There is a risk of failure or malfunction.

◆ Encoder Cables

These cables are not provided by Yaskawa. Use shielded cables. In addition, always connect the shield wire from the Encoder Cable to the connector (shell). Refer to the following tables for the pin layouts.

■ SERVOPACK (CN2) End of Cable

- Plug Connector: 55100-0670 (Molex Incorporated)
- Connector order number: JZSP-CMP9-1-E (SERVOPACK Connector Kit)

Pin	Signal	Function
1	PG5 V	Encoder power supply +5 V
2	PG0 V	Encoder power supply 0 V
3	–	–
4	–	–
5	PS	Serial data
6	/PS	
Shell	Shield	–

■ MQ10-□LA End of Cable

For details, refer to the specifications for the MQ10-□LA from Magnescale Co., Ltd..

■ Cables without Connectors

Name	Length (L)	Order Number		Reference
		Standard Cable	Flexible Cable	
Cables without Connectors	5 m	JZSP-CMP09-05-E	JZSP-CSP39-05-E	page 6-26
	10 m	JZSP-CMP09-10-E	JZSP-CSP39-10-E	
	15 m	JZSP-CMP09-15-E	JZSP-CSP39-15-E	

Note: We recommend that you use Flexible Cables.

SR-75, SR-77, SR-85, or SR-87 Linear Encoders



Important

1. You cannot use an SR-75, SR-77, SR-85, or SR-87 Linear Encoder with a Linear Servomotor with a Polarity Sensor.
2. If you use an SGLFW2 Servomotor, input the thermal protector signal from the Linear Servomotor to the host controller. The thermal protector signal is closed when the temperature is normal and open when the thermal protector is activated. Do not exceed 3 A or 30 V.

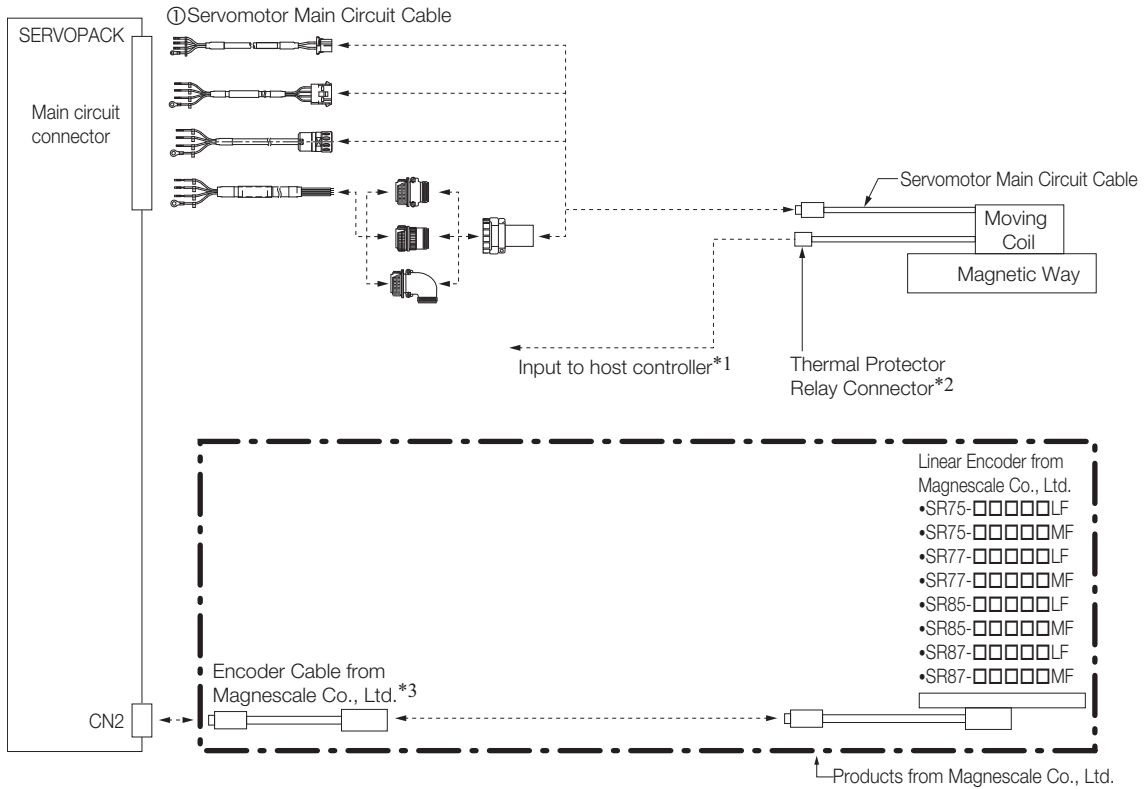

*1. Cables to connect to the host controller are not provided by Yaskawa. Refer to the following section for information on connector models.
 **JZSP-CL2TH00-□□-E Sensor Cables** on page 9-35

*2. Only SGLFW2 Servomotors come equipped with Thermal Protector Relay Connectors.

*3. Use an Encoder Cable from Magnescale Co., Ltd.. Contact Magnescale Co., Ltd. for details on Encoder Cable specifications.

No.	Cable Type	Reference
①	Servomotor Main Circuit Cables	page 9-25

SmartSCALE Linear Encoder (SQ47/SQ57)



1. You cannot use an SQ47 or SQ57 Linear Encoder with a Linear Servomotor with a Polarity Sensor.
2. If you use an SGLFW2 Servomotor, input the thermal protector signal from the Linear Servomotor to the host controller. The thermal protector signal is closed when the temperature is normal and open when the thermal protector is activated. Do not exceed 3 A or 30 V.

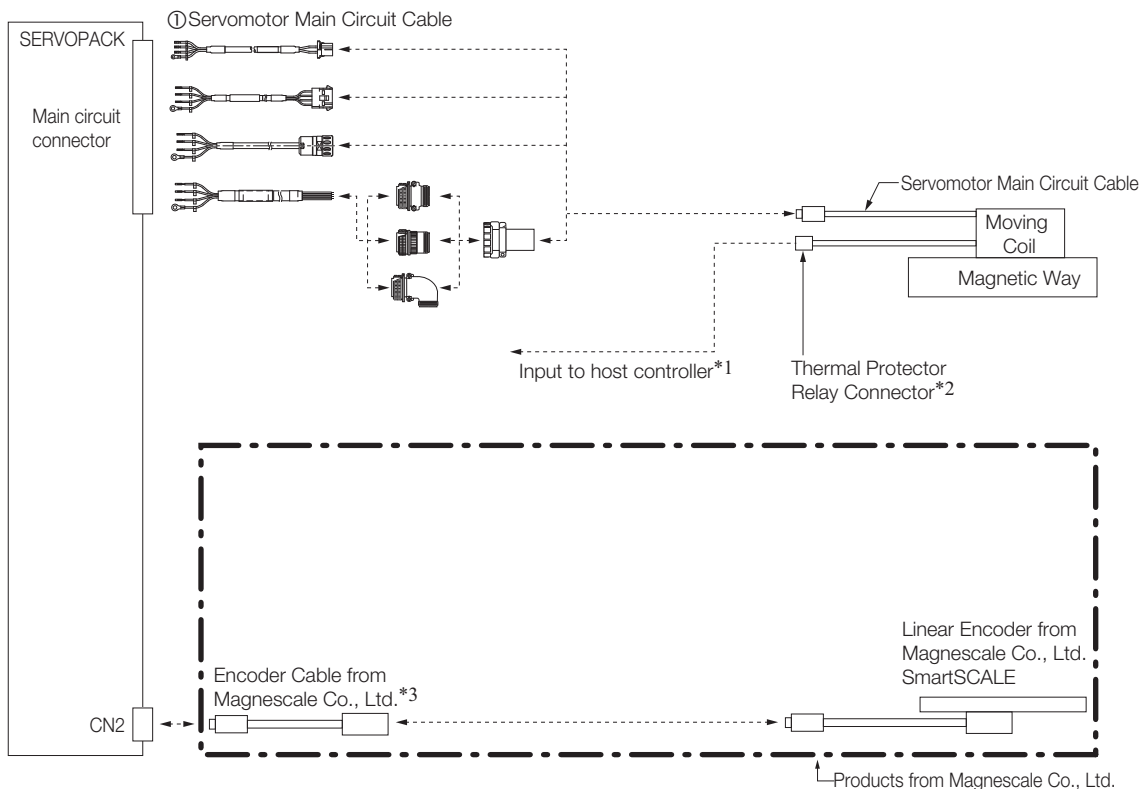

*1. Cables to connect to the host controller are not provided by Yaskawa. Refer to the following section for information on connector models.

JZSP-CL2TH00-□□-E Sensor Cables on page 9-35

*2. Only SGLFW2 Servomotors come equipped with Thermal Protector Relay Connectors.

*3. Use an Encoder Cable from Magnescale Co., Ltd.. Contact Magnescale Co., Ltd. for details on Encoder Cable specifications.

No.	Cable Type	Reference
①	Servomotor Main Circuit Cables	page 9-25

9.2.6 Connections to Linear Encoders from Mitutoyo Corporation

ST78□A, ST13□, or AT13□A Linear Encoder



Important

1. You cannot use an ST78□A Linear Encoder together with a Linear Servomotor with a Polarity Sensor.
2. If you use an SGLFW2 Servomotor, input the thermal protector signal from the Linear Servomotor to the host controller. The thermal protector signal is closed when the temperature is normal and open when the thermal protector is activated. Do not exceed 3 A or 30 V.

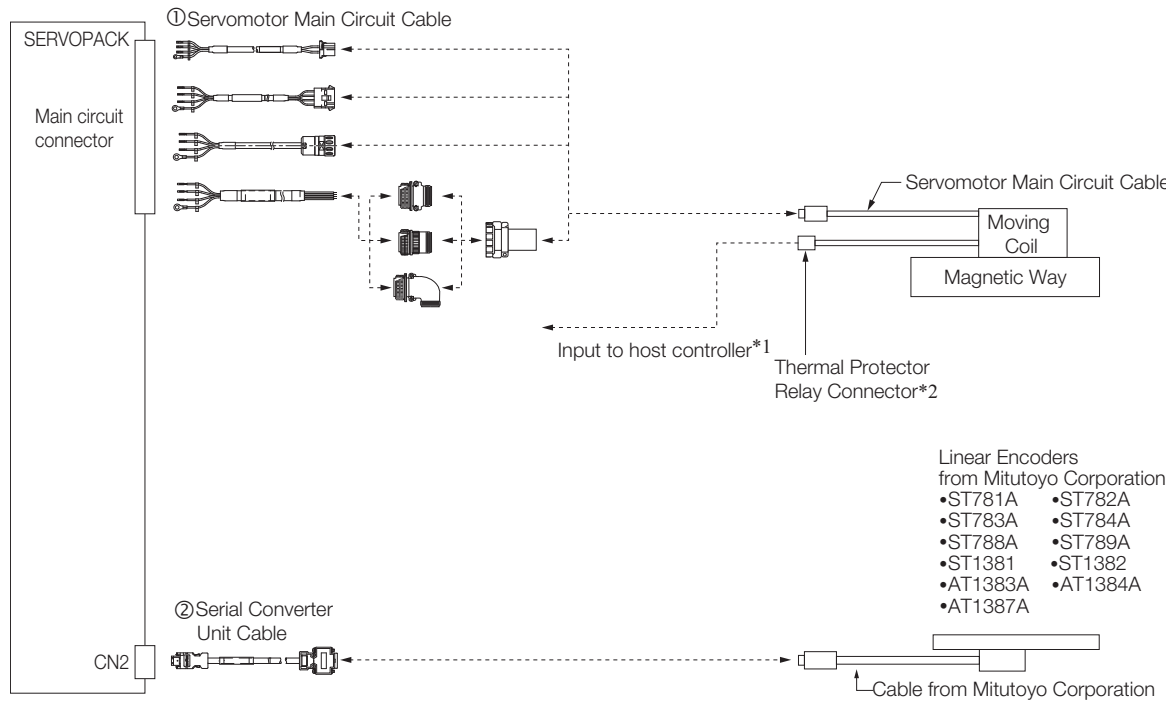

*1. Cables to connect to the host controller are not provided by Yaskawa. Refer to the following section for information on connector models.

 **JZSP-CL2TH00-□□-E Sensor Cables** on page 9-35

*2. Only SGLFW2 Servomotors come equipped with Thermal Protector Relay Connectors.

No.	Cable Type	Reference
①	Servomotor Main Circuit Cables	page 9-25
②	Serial Converter Unit Cables	page 9-26

9.2.7 Connections to Linear Encoder from Fagor Automation S. Coop.



1. You cannot use an Linear Encoder from Fagor Automation S. Coop. with a Linear Servomotor with a Polarity Sensor.
2. If you use an SGLFW2 Servomotor, input the thermal protector signal from the Linear Servomotor to the host controller. The thermal protector signal is closed when the temperature is normal and open when the thermal protector is activated. Do not exceed 3 A or 30 V.

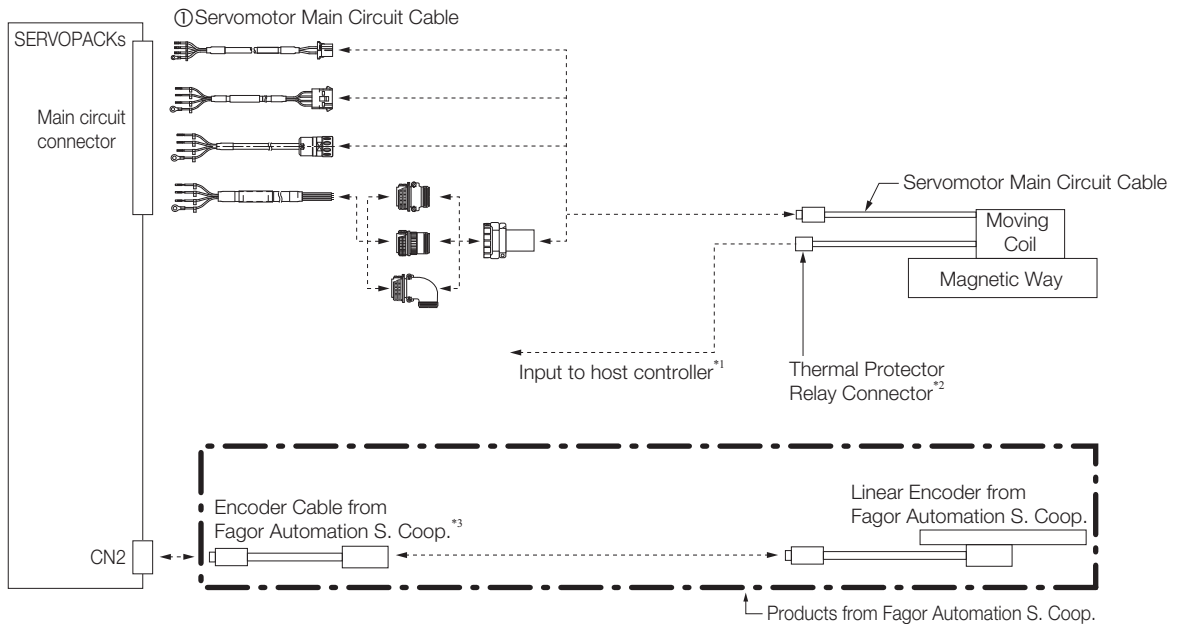

*1. Cables to connect to the host controller are not provided by Yaskawa. Refer to the following section for information on connector models.

JZSP-CL2TH00-□□-E Sensor Cables on page 9-35

*2. Only SGLFW2 Servomotors come equipped with Thermal Protector Relay Connectors.

*3. Use Encoder Cables from Fagor Automation S. Coop. For detailed specifications of the Encoder Cables, consult Fagor Automation S. Coop. or its sales representative.

No.	Cable Type	Reference
①	Servomotor Main Circuit Cable	page 9-25

9.2.8 Connections to Linear Encoder from Canon Precision Inc.



Important

1. You cannot use a Linear Encoder from Canon Precision Inc. together with a Linear Servomotor with a Polarity Sensor.
2. If you use an SGLFW2 Servomotor, input the thermal protector signal from the Linear Servomotor to the host controller. The thermal protector signal is closed when the temperature is normal and open when the thermal protector is activated. Do not exceed 3 A or 30 V.

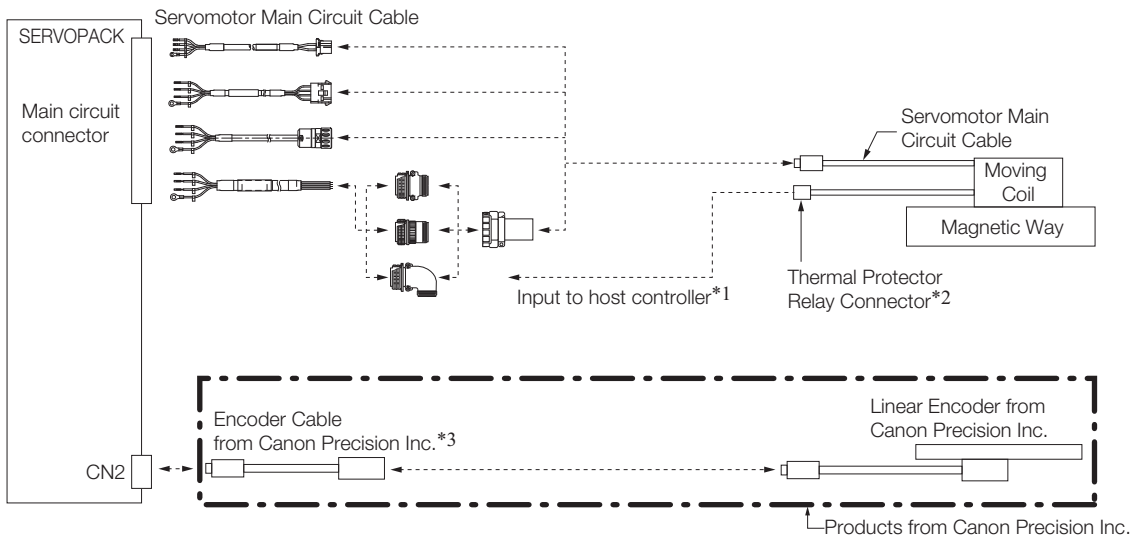

*1. Cables to connect to the host controller are not provided by Yaskawa. Refer to the following section for information on connector models.

 *JZSP-CL2TH00-□□-E Sensor Cables* on page 9-35

*2. Only SGLFW2 Servomotors come equipped with Thermal Protector Relay Connectors.

*3. Use an Encoder Cable from Canon Precision Inc. Contact Canon Precision Inc. for detailed Encoder Cable specifications.

9.3 Cable Selection Table

9.3.1 Servomotor Main Circuit Cables

Servomotor Model	Length (L)	Order Number	Appearance	Details
SGLGW-30A, -40A, or -60A SGLFW-20A or -35A	1 m	JZSP-CLN11-01-E		page 9-28
	3 m	JZSP-CLN11-03-E		
	5 m	JZSP-CLN11-05-E		
	10 m	JZSP-CLN11-10-E		
	15 m	JZSP-CLN11-15-E		
	20 m	JZSP-CLN11-20-E		
SGLGW-90A SGLFW-50A or -1ZA SGLTW-20A or -35A	1 m	JZSP-CLN21-01-E		page 9-28
	3 m	JZSP-CLN21-03-E		
	5 m	JZSP-CLN21-05-E		
	10 m	JZSP-CLN21-10-E		
	15 m	JZSP-CLN21-15-E		
	20 m	JZSP-CLN21-20-E		
SGLGW-30A□□□□□□□□ -40A□□□□□□□□ -60A□□□□□□□□ SGLFW-□□A□□□□□□□□ SGLTW-□□A□□□□□□□□	1 m	JZSP-CLN14-01-E		page 9-29
	3 m	JZSP-CLN14-03-E		
	5 m	JZSP-CLN14-05-E		
	10 m	JZSP-CLN14-10-E		
	15 m	JZSP-CLN14-15-E		
	20 m	JZSP-CLN14-20-E		
SGLTW-40A□□□□□□ -80A□□□□□□	1 m	JZSP-CLN39-01-E		page 9-29
	3 m	JZSP-CLN39-03-E		
	5 m	JZSP-CLN39-05-E		
	10 m	JZSP-CLN39-10-E		
	15 m	JZSP-CLN39-15-E		
	20 m	JZSP-CLN39-20-E		
SGLFW2-90A200A□ SGLFW2-90A380A□	1 m	JZSP-CL2N803-01-E		page 9-30
	3 m	JZSP-CL2N803-03-E		
	5 m	JZSP-CL2N803-05-E		
	10 m	JZSP-CL2N803-10-E		
	15 m	JZSP-CL2N803-15-E		
	20 m	JZSP-CL2N803-20-E		
SGLFW2-30A070A□ SGLFW2-30A120A□ SGLFW2-30A230A□	1 m	JZSP-CL2N703-01-E		page 9-30
	3 m	JZSP-CL2N703-03-E		
	5 m	JZSP-CL2N703-05-E		
	10 m	JZSP-CL2N703-10-E		
	15 m	JZSP-CL2N703-15-E		
	20 m	JZSP-CL2N703-20-E		
SGLFW2-45A200A□ SGLFW2-45A380A□	1 m	JZSP-CL2N603-01-E		page 9-31
	3 m	JZSP-CL2N603-03-E		
	5 m	JZSP-CL2N603-05-E		
	10 m	JZSP-CL2N603-10-E		
	15 m	JZSP-CL2N603-15-E		
	20 m	JZSP-CL2N603-20-E		

Continued on next page.

9.3 Cable Selection Table

9.3.2 Linear Encoder Cables

Continued from previous page.

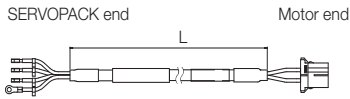
Servomotor Model	Length (L)	Order Number	Appearance	Details
SGLFW2-90A560A□ SGLFW2-1DA380A□ SGLFW2-1DA560A□	1 m	JZSP-CL2N503-01-E		page 9-32
	3 m	JZSP-CL2N503-03-E		
	5 m	JZSP-CL2N503-05-E		
	10 m	JZSP-CL2N503-10-E		
	15 m	JZSP-CL2N503-15-E		
	20 m	JZSP-CL2N503-20-E		

Note: Estimates are available for models other than those listed above (SGLFW2-90A380A□L, SGLFW2-90A560A□L, and SGLFW2-1D□□□□A□L).

- *1. Connector from TE Connectivity Japan G.K.
- *2. Connector from Hypertac GmbH
- *3. A connector is not provided on the Linear Servomotor end. Obtain a connector according to your specifications. Refer to the following section for information on connectors.
 ◆ JZSP-CLN39 Cable Connectors on page 9-29

9.3.2 Linear Encoder Cables

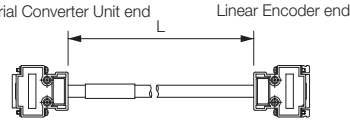
Name	Servomotor Model	Length (L)*	Order Number	Appearance	Details
For Linear Encoder from Renishaw plc	All models	1 m	JZSP-CLL00-01-E		page 9-32
		3 m	JZSP-CLL00-03-E		
		5 m	JZSP-CLL00-05-E		
		10 m	JZSP-CLL00-10-E		
		15 m	JZSP-CLL00-15-E		
For Linear Encoder from Dr. JOHANNES HEIDENHAIN GmbH		1 m	JZSP-CLL30-01-E		
		3 m	JZSP-CLL30-03-E		
		5 m	JZSP-CLL30-05-E		
		10 m	JZSP-CLL30-10-E		
		15 m	JZSP-CLL30-15-E		

* When using a JZDP-J00□-□□□-E Serial Converter Unit, do not exceed a cable length of 3 m.

9.3.3 Serial Converter Unit Cables

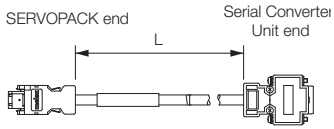
Servomotor Model	Length (L)	Order Number	Appearance	Details
All models	1 m	JZSP-CLP70-01-E		page 9-33
	3 m	JZSP-CLP70-03-E		
	5 m	JZSP-CLP70-05-E		
	10 m	JZSP-CLP70-10-E		
	15 m	JZSP-CLP70-15-E		
	20 m	JZSP-CLP70-20-E		

9.3.4 Sensor Cables

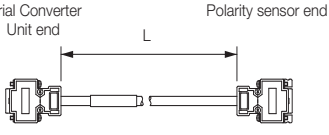
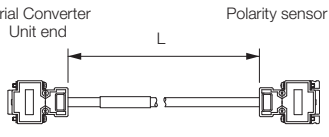
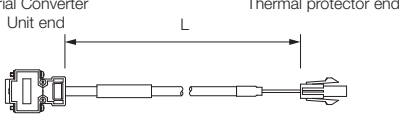
Servomotor Model	Length (L)	Order Number	Appearance	Details
SGLGW-□□A SGLFW-□□A SGLTW-□□A	1 m	JZSP-CLL10-01-E		page 9-34
	3 m	JZSP-CLL10-03-E		
	5 m	JZSP-CLL10-05-E		
	10 m	JZSP-CLL10-10-E		
	15 m	JZSP-CLL10-15-E		
SGLFW2- □□A□□□AS□ (with Polarity Sensor)	1 m	JZSP-CL2L100-01-E		page 9-34
	3 m	JZSP-CL2L100-03-E		
	5 m	JZSP-CL2L100-05-E		
	10 m	JZSP-CL2L100-10-E		
	15 m	JZSP-CL2L100-15-E		
SGLFW2-□□A□□□ AT□ (without Polarity Sensor)	1 m	JZSP-CL2TH00-01-E		page 9-35
	3 m	JZSP-CL2TH00-03-E		
	5 m	JZSP-CL2TH00-05-E		
	10 m	JZSP-CL2TH00-10-E		
	15 m	JZSP-CL2TH00-15-E		

9.3.5 Encoder Cables

The cables in the following table can be used either for Absolute Linear Encoders or Incremental Linear Encoders.

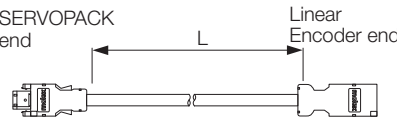
Servomotor Model	Length (L)	Order Number		Appearance	Details
		Standard Cable	Flexible Cable		
All models	3 m	JZSP-CMP00-03-E	JZSP-CMP10-03-E		page 9-35
	5 m	JZSP-CMP00-05-E	JZSP-CMP10-05-E		
	10 m	JZSP-CMP00-10-E	JZSP-CMP10-10-E		
	15 m	JZSP-CMP00-15-E	JZSP-CMP10-15-E		
	20 m	JZSP-CMP00-20-E	JZSP-CMP10-20-E		

9.3.6 Cable Dimensional Drawings and Wiring Specifications

JZSP-CLN11-□□-E Servomotor Main Circuit Cables

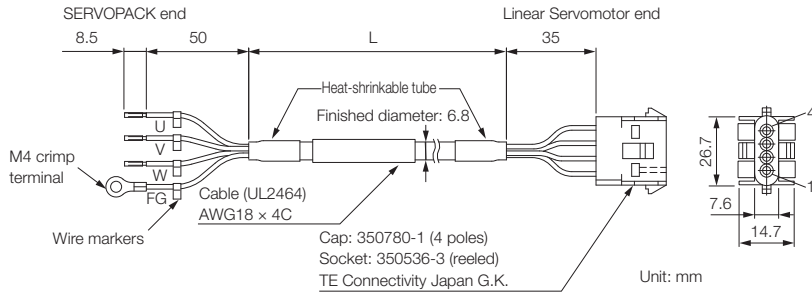

• Wiring Specifications

SERVOPACK Leads		Servomotor Connector	
Wire Color	Signal	Signal	Pin
Red	Phase U	Phase U	1
White	Phase V	Phase V	2
Blue	Phase W	Phase W	3
Green/yellow	FG	FG	4

JZSP-CLN21-□□-E Servomotor Main Circuit Cables

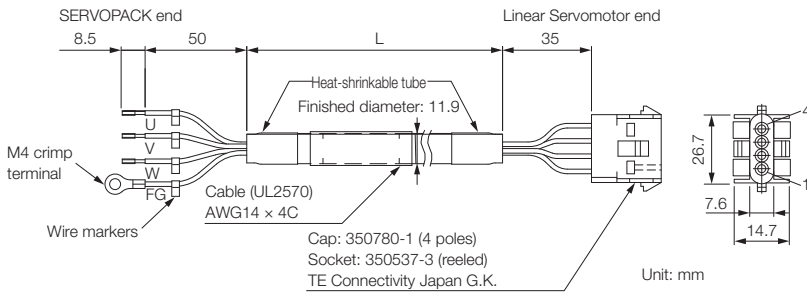

• Wiring Specifications

SERVOPACK Leads		Servomotor Connector	
Wire Color	Signal	Signal	Pin
Red	Phase U	Phase U	1
White	Phase V	Phase V	2
Blue	Phase W	Phase W	3
Green/yellow	FG	FG	4

JZSP-CLN14-□□-E Servomotor Main Circuit Cables

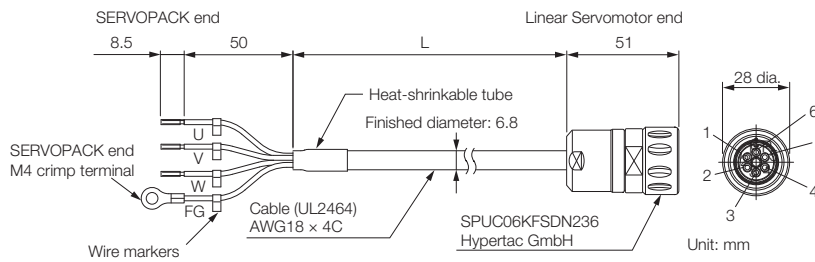

• Wiring Specifications

SERVOPACK Leads		Servomotor Connector	
Wire Color	Signal	Signal	Pin
Black (white 1)	Phase U	Phase U	1
Black (white 2)	Phase V	Phase V	2
Black (white 3)	Phase W	Phase W	3
Green/yellow	FG	-	4
		-	5
		FG	6

JZSP-CLN39-□□-E Servomotor Main Circuit Cables

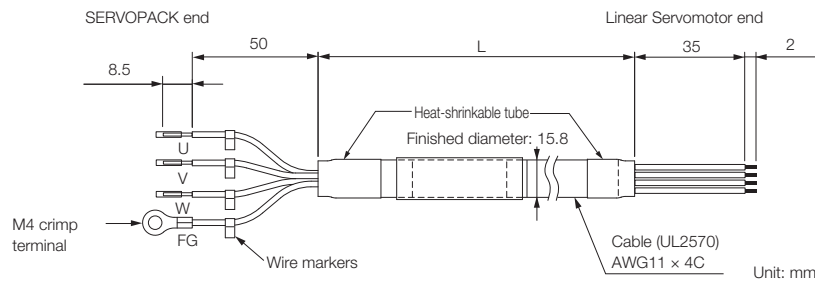

• Wiring Specifications

SERVOPACK Leads		Servomotor connector	
Wire Color	Signal	Signal	Pin
Red	Phase U	Phase U	A
White	Phase V	Phase V	B
Blue	Phase W	Phase W	C
Green/yellow	FG	FG	D

◆ JZSP-CLN39 Cable Connectors

Applicable Servomotor	Connector Provided with Servomotor	Plug		Cable Clamp
		Straight	Right-Angle	
SGLTW-40 or -80	MS3102A22-22P	MS3106B22-22S or MS3106A22-22S	MS3108B22-22S	MS3057-12A

■ MS3106B22-2S: Straight Plug with Two-Piece Shell

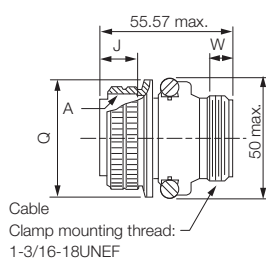

Shell Size	Joint Thread A	Length of Joint J ±0.12	Joint Nut Outer Diameter Q ⁺⁰ / _{-0.38} Dia.	Effective Thread Length W Min.
22	1-3/8-18UNEF	18.26	40.48	9.53

Unit: mm

■ MS3106A22-2S: Straight Plug with Solid Shell

Unit: mm

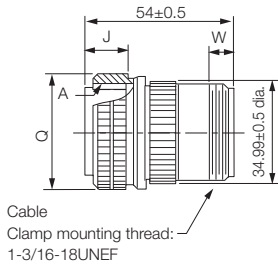

Shell Size	Joint Thread A	Length of Joint J ±0.12	Joint Nut Outer Diameter Q ⁺⁰ / _{-0.38} Dia.	Effective Thread Length W Min.
22	1-3/8-18UNEF	18.26	40.48	9.53

■ MS3108B22-2S: Right-Angle Plug with Two-Piece Shell

Unit: mm

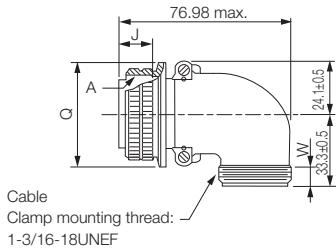

Shell Size	Joint Thread A	Length of Joint J ±0.12	Joint Nut Outer Diameter Q ⁺⁰ / _{-0.38} Dia.	Effective Thread Length W Min.
22	1-3/8-18UNEF	18.26	40.48	9.53

■ MS3057-12A: Cable Clamp with Rubber Bushing

Unit: mm

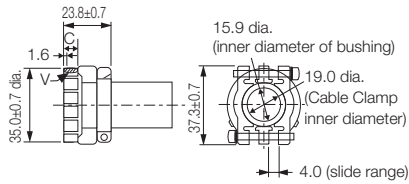

Applicable Connector Shell Size	Effective Thread Length C	Mounting Thread V	Attached Bushing
20.22	10.3	1-3/16-18UNEF	AN3420-12

JZSP-CL2N803-□□-E Servomotor Main Circuit Cables

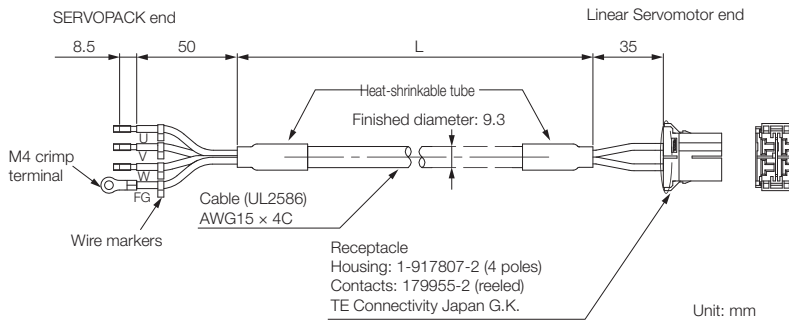

Unit: mm

• Wiring Specifications

SERVOPACK Leads		Servomotor Connector	
Wire Color	Signal	Signal	Pin
Red	Phase U	Phase U	A1
White	Phase V	Phase V	A2
Black	Phase W	Phase W	B1
Green	FG	FG	B2

JZSP-CL2N703-□□-E Servomotor Main Circuit Cables

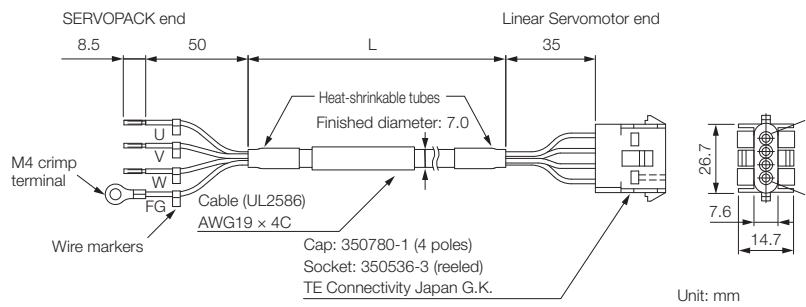

• Wiring Specifications

SERVOPACK Leads		Servomotor connector	
Wire Color	Signal	Signal	Pin
Red	Phase U	Phase U	1
White	Phase V	Phase V	2
Black	Phase W	Phase W	3
Green	FG	FG	4

JZSP-CL2N603-□□-E Servomotor Main Circuit Cables

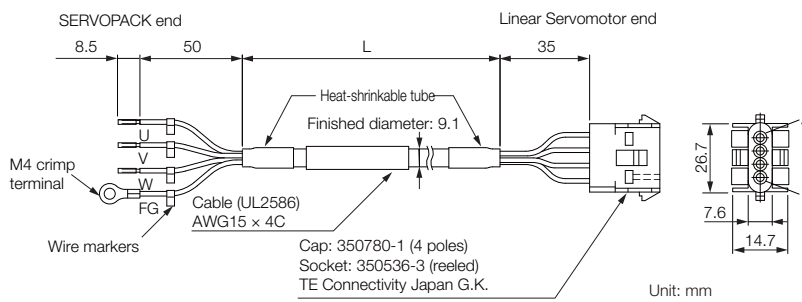

• Wiring Specifications

SERVOPACK Leads		Servomotor connector	
Wire Color	Signal	Signal	Pin
Red	Phase U	Phase U	1
White	Phase V	Phase V	2
Black	Phase W	Phase W	3
Green	FG	FG	4

JZSP-CL2N503-□□-E Servomotor Main Circuit Cables

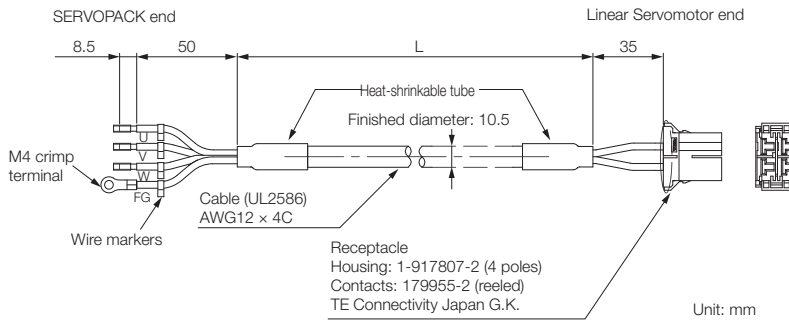

• Wiring Specifications

SERVOPACK Leads		Servomotor Connector	
Wire Color	Signal	Signal	Pin
Red	Phase U	Phase U	A1
White	Phase V	Phase V	A2
Black	Phase W	Phase W	B1
Green	FG	FG	B2

JZSP-CLL00-□□-E Linear Encoder Cables

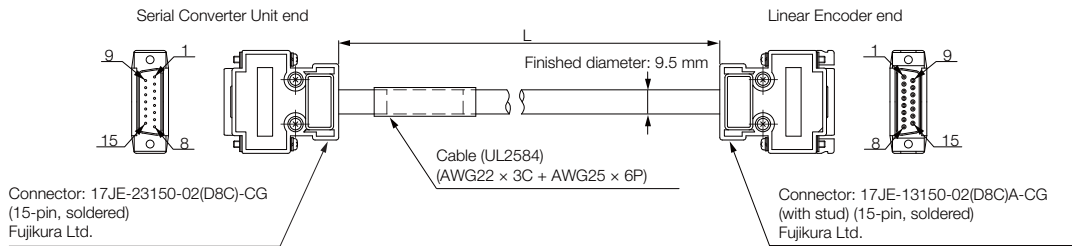

• Wiring Specifications

Serial Converter Unit end		Linear Encoder end	
Pin	Signal	Pin	Signal
1	/Cos (V1-)	1	/Cos (V1-)
2	/Sin (V2-)	2	/Sin (V2-)
3	Ref (V0+)	3	Ref (V0+)
4	+5 V	4	+5 V
5	5 Vs	5	5 Vs
6	BID	6	BID
7	Vx	7	Vx
8	Vq	8	Vq
9	Cos (V1+)	9	Cos (V1+)
10	Sin (V2+)	10	Sin (V2+)
11	/Ref (V0+)	11	/Ref (V0-)
12	0 V	12	0 V
13	0 Vs	13	0 Vs
14	DIR	14	DIR
15	Inner shield	15	Inner shield
Case	Shield	Case	Shield

JZSP-CLL30-□□-E Linear Encoder Cables

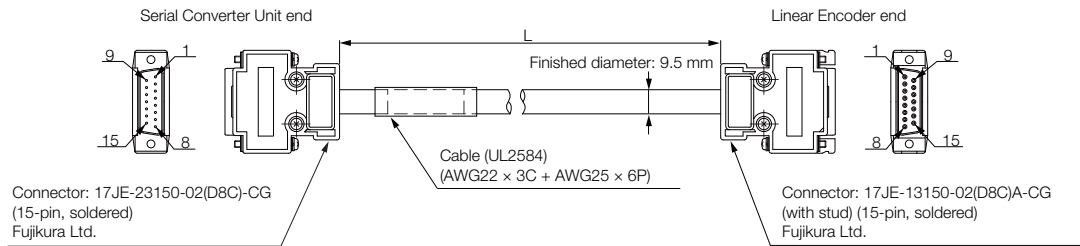

• Wiring Specifications

Serial Converter Unit end			Linear Encoder end		
Pin	Signal		Pin	Signal	
1	Cos (A+)	Shield wire	1	Cos (A+)	
2	0 V		2	0 V	
3	Sin (B+)		3	Sin (B+)	
4	+5 V		4	+5 V	
5	-		5	-	
6	-		6	-	
7	/Ref (R-)		7	/Ref (R-)	
8	-		8	-	
9	/Cos (A-)		9	/Cos (A-)	
10	0 Vs		10	0 Vs	
11	/Sin (B-)		11	/Sin (B-)	
12	5 Vs		12	5 Vs	
13	-		13	-	
14	Ref (R+)		14	Ref (R+)	
15	-		15	-	
Case	Shield	Case	Shield		

JZSP-CLP70-□□-E Serial Converter Unit Cables

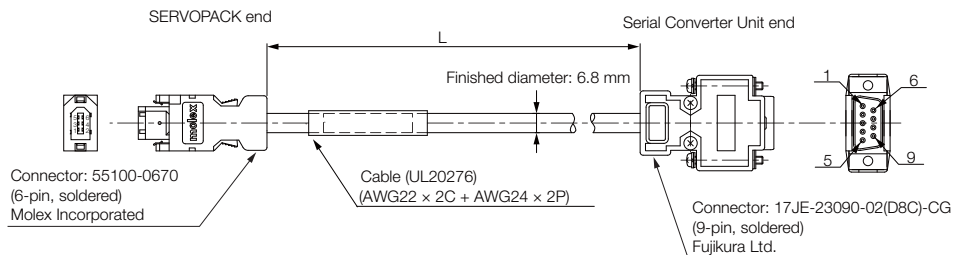

• Wiring Specifications

SERVOPACK end			Serial Converter Unit end		
Pin	Signal	Wire Color	Pin	Signal	Wire Color
1	PG5 V	Orange	1	+5 V	Orange
2	PG0 V	Green	5	0 V	Green
3	-	-	3	-	-
4	-	-	4	-	-
5	PS	Light blue/red	2	Phase-S output	Light blue/red
6	/PS	Light blue/black	6	/Phase-S output	Light blue/black
Shell	Shield	-	Case	Shield	-
			7	-	-
			8	-	-
			9	-	-

JZSP-CLL10-□□-E Sensor Cables

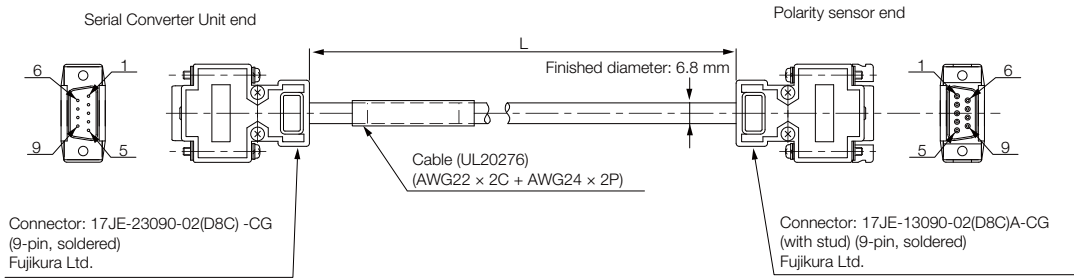

• Wiring Specifications

Serial Converter Unit end		Polarity sensor end	
Pin	Signal	Pin	Signal
1	+5 V	1	+5 V
2	Phase-U input	2	Phase-U input
3	Phase-V input	3	Phase-V input
4	Phase-W input	4	Phase-W input
5	0 V	5	0 V
6	-	6	-
7	-	7	-
8	-	8	-
9	-	9	-
Case	Shield	Case	Shield

Shield wire

JZSP-CL2L100-□□-E Sensor Cables

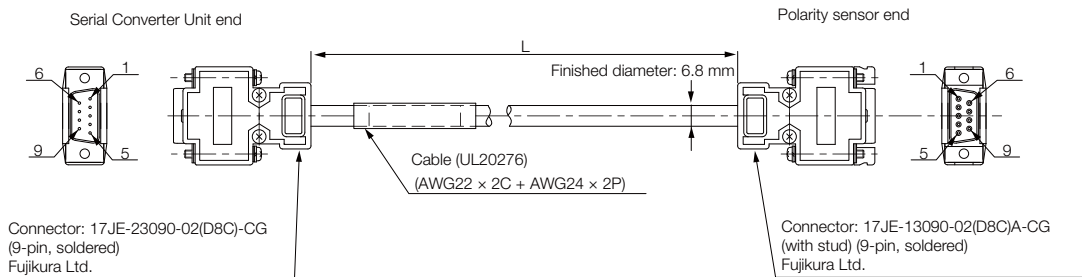

• Wiring Specifications

Serial Converter Unit end		Polarity sensor end	
Pin	Signal	Pin	Signal
1	+5 V, Thermal Protector	1	+5 V, Thermal Protector
2	Phase-U input	2	Phase-U input
3	Phase-V input	3	Phase-V input
4	Phase-W input	4	Phase-W input
5	0 V	5	0 V
6	-	6	-
7	-	7	-
8	-	8	-
9	Thermal Protector	9	Thermal Protector
Case	Shield	Case	Shield

Shield wire

JZSP-CL2TH00-□□-E Sensor Cables

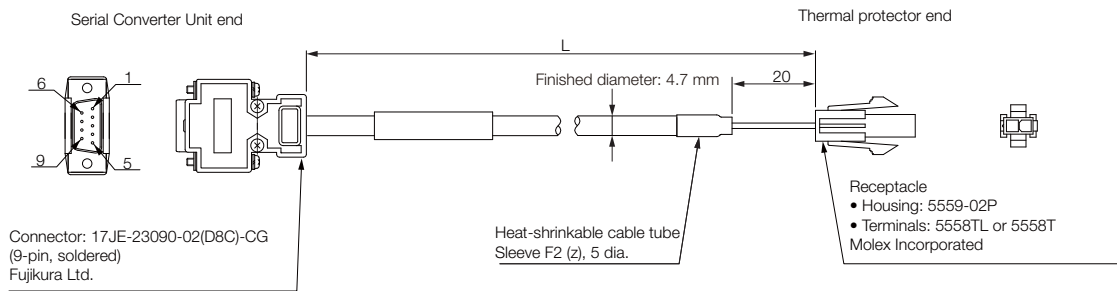

• Wiring Specifications

Serial Converter Unit end		Thermal protector end	
Pin	Signal	Pin	Signal
1	+5 V, Thermal Protector	1	+5 V, Thermal Protector
2	-	2	Thermal Protector
3	-		
4	-		
5	-		
6	-		
7	-		
8	-		
9	Thermal Protector		

Encoder Cables JZSP-CMP00-□□-E (Standard Cables) and JZSP-CMP10-□□-E (Flexible Cables)

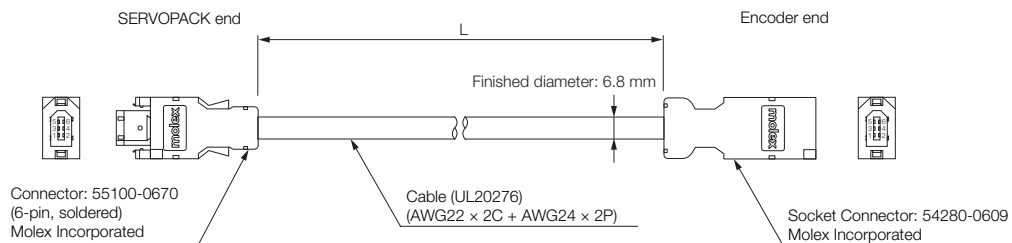

• Wiring Specifications

Standard Cable				Flexible Cable			
SERVOPACK end		Encoder end		SERVOPACK end		Encoder end	
Pin	Signal	Pin	Wire Color	Pin	Signal	Pin	Wire Color
1	PG 5 V	1	Red	1	PG 5 V	1	Orange
2	PG 0 V	2	Black	2	PG 0 V	2	Light green
5	PS	5	Light blue	5	PS	5	Red/light blue
6	/PS	6	Light blue/white	6	/PS	6	Black/light blue
Shell	FG	7	FG shield wire	Shell	FG	7	FG shield wire

9.3.7 Wiring Precautions

Precautions for Standard Cables

Do not use standard cables in applications that require a high degree of flexibility, such as twisting and turning, or in which the cables themselves must move. When you use Standard Cables, observe the recommended bending radius given in the following table and perform all wiring so that stress is not applied to the cables. Use the cables so that they are not repeatedly bent.

Cable Diameter	Recommended Bending Radius (R)
Less than 8 mm	15 mm min.
8 mm	20 mm min.
Over 8 mm	Cable diameter × 3 mm min.

Precautions for Flexible Cables

The Flexible Cables have a service life of 10,000,000 operations minimum when used at the recommended bending radius (R) or larger under the following test conditions. The service life of a Flexible Cable is reference data under the following test conditions. The service life of a Flexible Cable greatly depends on the amount of mechanical shock, how the cable is attached, and how the cable is secured.

◆ Test Conditions

- One end of the cable is repeatedly moved forward and backward for 320 mm using the test equipment shown in the following figure.
- The fixed end is connected to a non-moving part, the moving end is connected to the moving part, and the number of cable return operations until a lead wire breaks are counted. One round trip is counted as one bend.

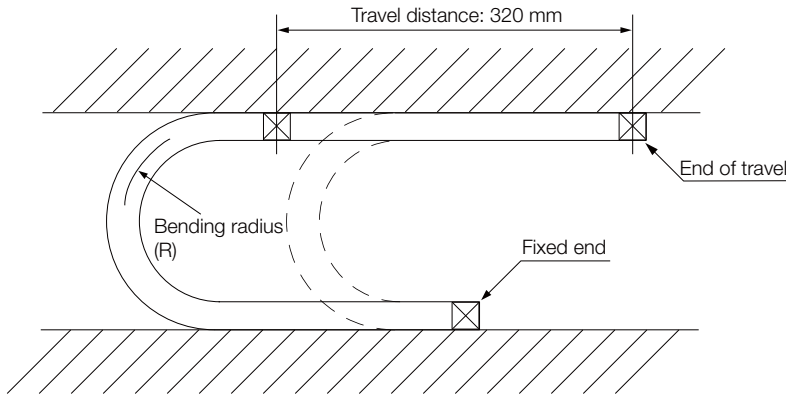

Note: The service life of a Flexible Cable indicates the number of bends while the lead wires are electrically charged for which no cracks or damage that affects the performance of the cable sheathing occurs. Breaking of the shield wire is not considered.

◆ Recommended Cable Bending Radii

Type	Model	Recommended Bending Radius (R) [mm]
Linear Servomotor Main Circuit Cable	JZSP-CLN11-□□-E	35
	JZSP-CLN21-□□-E	75
	JZSP-CLN39-□□-E	100
	JZSP-CLN14-□□-E	35
	JZSP-CL2N803-□□-E	70
	JZSP-CL2N703-□□-E	50
	JZSP-CL2N603-□□-E	60
	JZSP-CL2N503-□□-E	70
Linear Encoder Cable	JZSP-CLL00-□□-E	57
	JZSP-CLL30-□□-E	
Sensor Cable	JZSP-CLL10-□□-E	46
	JZDP-CL2L100-□□-E	
Serial Converter Unit Cable	JZSP-CL2TH00-□□-E	46
Cables with Connectors on Both Ends (for incremental or absolute encoder)	JZSP-CLP70-□□-E	
Cables without Connectors	JZSP-CMP10-□□-E	
	JZSP-CSP39-□□-E	





9.4 Serial Converter Unit

9.4.1 Selection Table

Order Numbers

Use the following tables to select the Serial Converter Unit.

JZDP - □00□ - □□□*

Serial Converter Unit Model					Applicable Linear Servomotors					
Code	Appearance	Applicable Linear Encoder	Polarity Sensor	Thermal Protector	Servomotor Model	Code	Servomotor Model	Code		
H003 J003		From Dr. JOHANNES HEIDENHAIN GmbH	Not provided	Not provided	SGLGW- (coreless models) For Standard-Force Magnetic Way	30A050C	250	SGLFW (models with F-type iron cores)	20A090A	017
						30A080C	251		20A120A	018
40A140C	252	35A120A	019							
40A253C	253	35A230A	020							
40A365C	254	50A200B	181							
60A140C	258	50A380B	182							
60A253C	259	1ZA200B	183							
60A365C	260	1ZA380B	184							
90A200C	264	20A170A	011							
90A370C	265	20A320A	012							
90A535C	266	20A460A	013							
H005 J005		From Renishaw plc	Not provided	Not provided	SGLGW- + SGLGM- □-M (coreless models) For High-Force Magnetic Way	40A140C	255	SGLTW- (models with T-type iron cores)	35A170A	014
						40A253C	256		35A320A	015
						40A365C	257		35A460A	016
						60A140C	261		35A170H	105
						60A253C	262		35A320H	106
						60A365C	263		50A170H	108
H006 J006		From Dr. JOHANNES HEIDENHAIN GmbH	Provided	Provided	SGLFW2 (models with F-type iron cores)	30A070A	628	50A320H	109	
						30A120A	629	40A400B	185	
						30A230A	630	40A600B	186	
						45A200A	631	80A400B	187	
						45A380A	632	80A600B	188	
						90A200A□1	633			
						90A380A□1	634			
						90A560A□1	648			
						1DA380A□1	649			
						1DA560A□1	650			
90A200A□L	699									
90A380A□L	700									
90A560A□L	701									
1DA380A□L	702									
1DA560A□L	703									
H008 J008		From Renishaw plc	Provided	Provided						

* If you will connect the Serial Converter Unit to the Fully-closed Module, select JZDP-□00□-000.

9.4.2 Characteristics and Specifications

Item		JZDP-H00□-□□□	JZDP-J00□-□□□
Electrical Specifications	Power Supply Voltage	+5.0 V ±5%, ripple content: 5% max.	
	Current Consumption* ¹	120 mA Typ, 160 mA max.	
	Signal Resolution	1/256 pitch of input two-phase sine wave	1/4,096 pitch of input two-phase sine wave
	Maximum Response Frequency	250 kHz	100 kHz
	Analog Input Signals* ² (cos, sin, and Ref)	Differential input amplitude: 0.4 V to 1.2 V Input signal level: 1.5 V to 3.5 V	
	Polarity Sensor Input Signal	CMOS level	
	Thermal Protector Input Signal	Connect the thermal protector built into the Linear Servomotor * ³	
	Output Signals	Position data, polarity sensor information, and alarms	
	Output Method	Serial data transmission	
	Output Circuit	Balanced transceiver (SN75LBC176 or the equivalent), internal terminating resistance: 120 Ω	
Mechanical Characteristics	Approximate Mass	150 g	
	Vibration Resistance	98 m/s ² max. (10 Hz to 2,500 Hz) in three directions	
	Shock Resistance	980 m/s ² , (11 ms) two times in three directions	
Environment	Operating Temperature Range	0°C to 55°C	
	Storage Temperature Range	-20°C to 80°C	
	Humidity Range	20% to 90% relative humidity (with no condensation)	

*1. The current consumptions of the Linear Encoder and the polarity sensor are not included in this value. The current consumption of the polarity sensor is approximately 40 mA. Confirm the current consumption of the Linear Encoder that you will use and make sure that the current capacity of the SERVOPACK is not exceeded.

*2. If you input an out-of-range value, the correct position information will not be output. Also, the device may be damaged.

*3. Only SGLFW2 Servomotors come equipped with thermal protectors.

9.4.3 External Dimensions

Serial Converter Unit without Polarity Sensor Cable (for Linear Encoder from Dr. JOHANNES HEIDENHAIN GmbH)

◆ Model: JZDP-□003-□□□

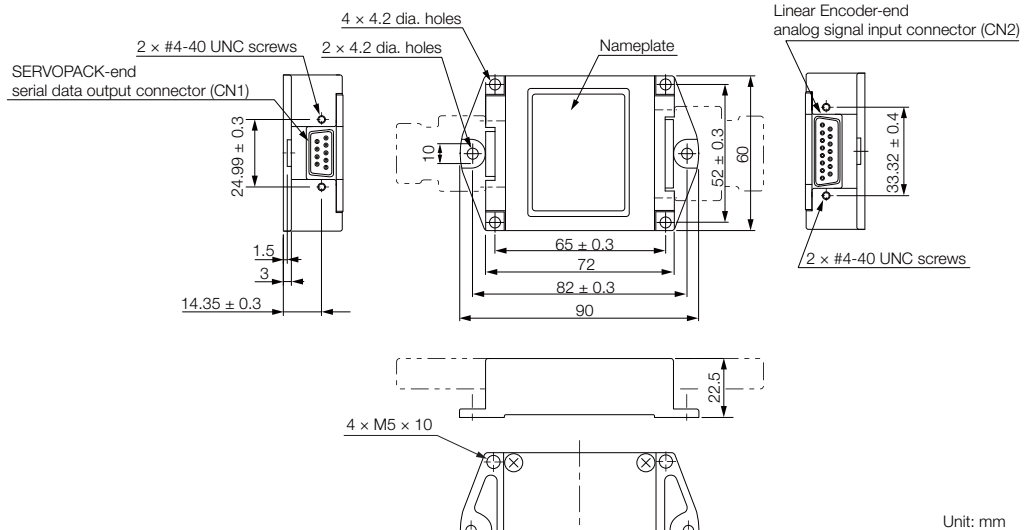

Pin	Signal
1	+ 5 V
2	Phase-S output
3	Not used
4	Not used
5	0 V
6	/Phase-S output
7	Not used
8	Not used
9	Not used
Case	Shield

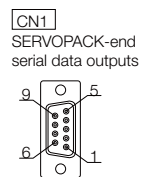

17-Series Connector:
17LE-13090-27-FA
from Fujikura Ltd.
(Socket)

Pin	Signal
1	cos input (A+)
2	0 V
3	sin input (B+)
4	+ 5 V
5	Not used
6	Not used
7	/Ref input (R-)
8	Not used
9	/cos input (A-)
10	0 V sensor
11	/sin input (B-)
12	5 V sensor
13	Not used
14	Ref input (R+)
15	Not used
Case	Shield

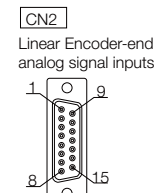

17-Series Connector:
17LE-13150-27-FA
from Fujikura Ltd.
(Socket)

Note: 1. Do not connect the unused pins.

2. Contact Dr. JOHANNES HEIDENHAIN GmbH for details on cables (analog 1 Vp-p output, D-sub 15-pin, male) from Dr. JOHANNES HEIDENHAIN GmbH.

Serial Converter Unit without Polarity Sensor Cable (for Linear Encoder from Renishaw plc)

◆ Model: JZDP-□005-□□□

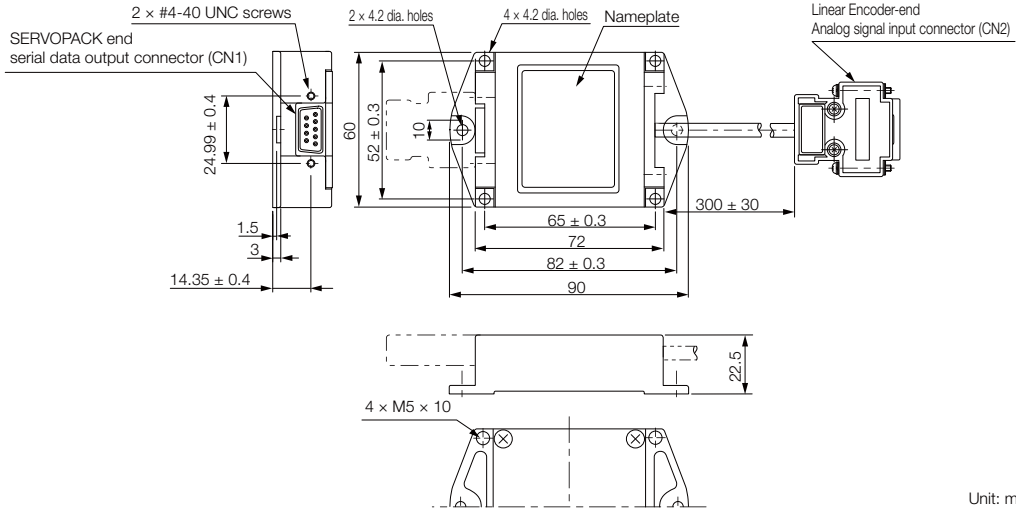

Unit: mm

Pin	Signal
1	+ 5 V
2	Phase-S output
3	Not used
4	Not used
5	0 V
6	/Phase-S output
7	Not used
8	Not used
9	Not used
Case	Shield

CN1

SERVOPACK-end serial data outputs

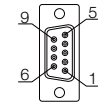

17-Series Connector:
17LE-13090-27-FA
from Fujikura Ltd.
(Socket)

Pin	Signal
1	cos input (V1-)
2	sin input (V2-)
3	Ref input (V0+)
4	+ 5 V
5	5 Vs
6	Not used
7	Not used
8	Not used
9	cos input (V1+)
10	sin input (V2+)
11	/Ref input (V0-)
12	0 V
13	0 Vs
14	Not used
15	Inner shield (0 V)
Case	Shield

CN2

Linear Encoder-end analog signal inputs

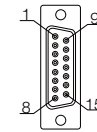

17-Series Connector:
17JE-13150-02 (D8C) A-CG
from Fujikura Ltd.
(Socket)

Note: 1. Do not connect the unused pins.

2. Contact Renishaw plc for details on cables (analog 1 Vp-p output, D-sub 15-pin, male) from Renishaw plc. However, the BID and DIR signals are not connected.

3. Use the Linear Encoder connector to change the origin position specifications of the Linear Encoder.

Serial Converter Unit with Polarity Sensor Cable (for Linear Encoder from Dr. JOHANNES HEIDENHAIN GmbH)

◆ Model: JZDP-□006-□□□

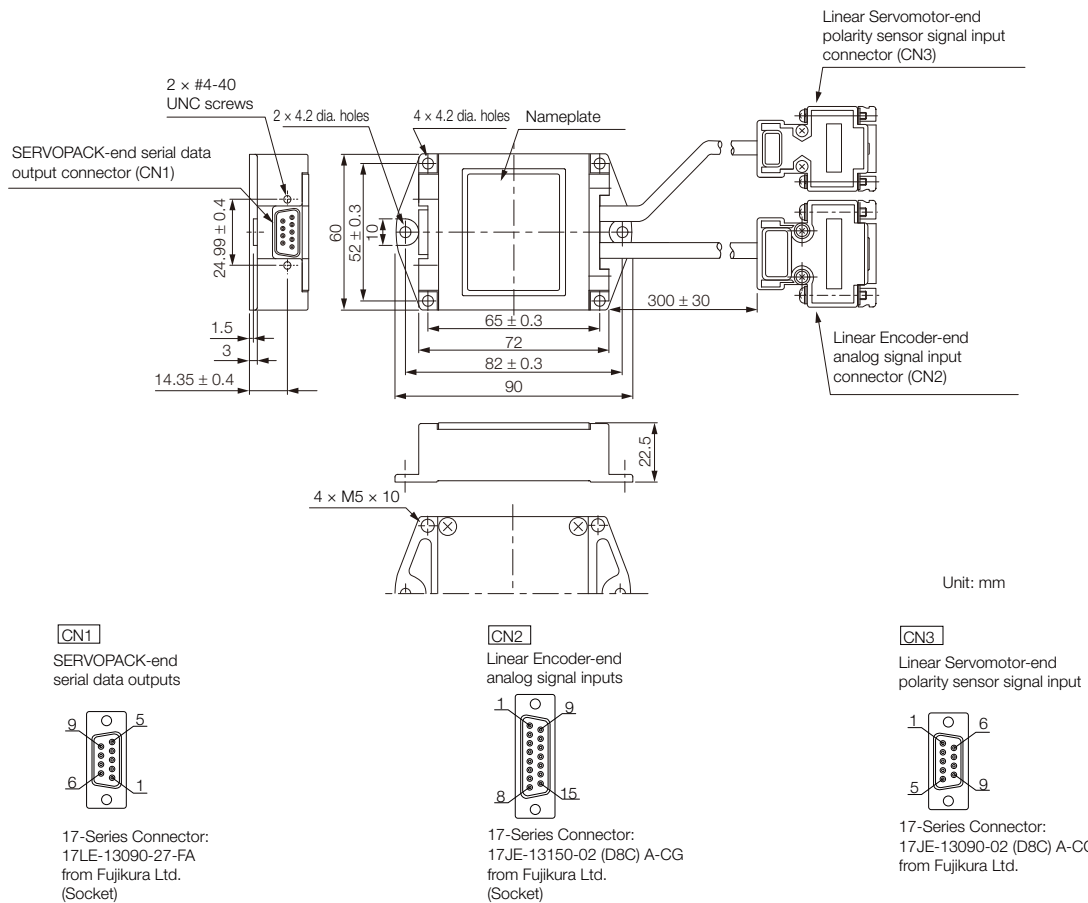

Pin	Signal
1	+ 5 V
2	Phase-S output
3	Not used
4	Not used
5	0 V
6	/Phase-S output
7	Not used
8	Not used
9	Not used
Case	Shield

Pin	Signal	Pin	Signal
1	cos input (A+)	9	/cos input (A-)
2	0 V	10	0 V sensor
3	sin input (B+)	11	/sin input (B-)
4	+ 5 V	12	5 V sensor
5	Not used	13	Not used
6	Not used	14	Ref input (R+)
7	/Ref input (R-)	15	Not used
8	Not used	Case	Shield

Pin	Signal
1	+5 V
2	Phase-U input
3	Phase-V input
4	Phase-W input
5	0 V
6	Not used
7	Not used
8	Not used
9	Thermal protector input
Case	Shield

Note: 1. Do not connect the unused pins.

2. Contact Dr. JOHANNES HEIDENHAIN GmbH for details on cables (analog 1 Vp-p output, D-sub 15-pin, male) from Dr. JOHANNES HEIDENHAIN GmbH.

3. The phase U, V, and W inputs are internally pulled up with 10 kΩ.

Serial Converter Unit with Polarity Sensor Cable (for Linear Encoder from Renishaw plc)

◆ Model: JZDP-□008-□□□

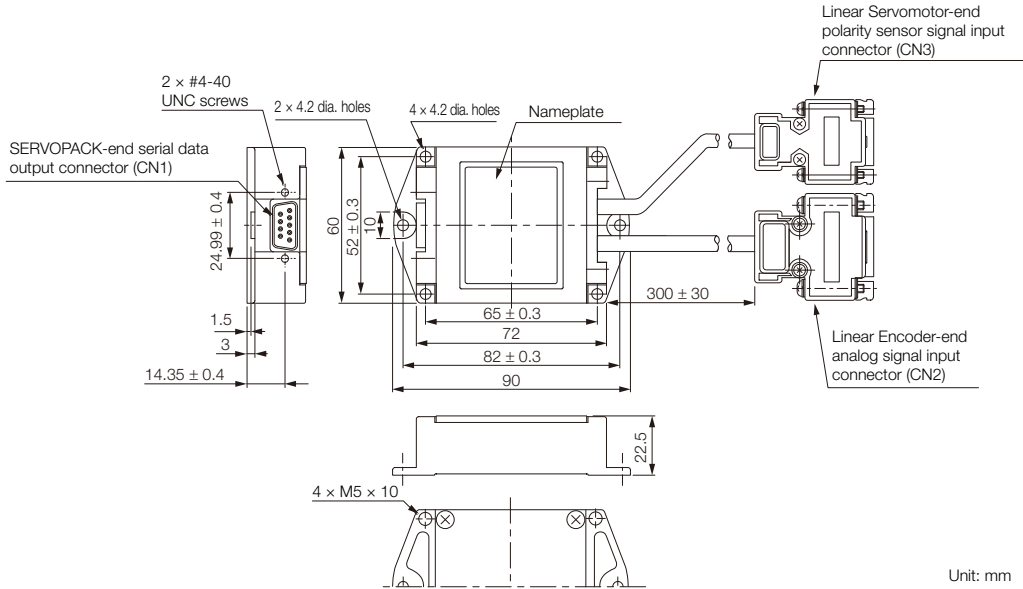

Unit: mm

CN1

SERVOPACK-end serial data outputs

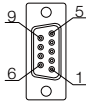

17-Series Connector:
17LE-13090-27-FA
from Fujikura Ltd.
(Socket)

CN2

Linear Encoder-end analog signal inputs

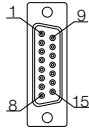

17-Series Connector:
17JE-13150-02 (D8C) A-CG
from Fujikura Ltd.
(Socket)

CN3

Linear Servomotor-end polarity sensor signal input

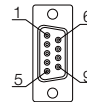

17-Series Connector:
17JE-13090-02 (D8C) A-CG
from Fujikura Ltd.

Pin	Signal
1	+ 5 V
2	Phase-S output
3	Not used
4	Not used
5	0 V
6	/Phase-S output
7	Not used
8	Not used
9	Not used
Case	Shield

Pin	Signal	Pin	Signal
1	/cos input (V1-)	9	cos input (V1+)
2	/sin input (V2-)	10	sin input (V2+)
3	Ref input (V0+)	11	/Ref input (V0-)
4	+ 5 V	12	0 V
5	5 Vs	13	0 Vs
6	Not used	14	Not used
7	Not used	15	Inner shield
8	Not used	Case	Shield

Pin	Signal
1	+ 5 V
2	Phase-U input
3	Phase-V input
4	Phase-W input
5	0 V
6	Not used
7	Not used
8	Not used
9	Thermal protector input
Case	Shield

Note: 1. Do not connect the unused pins.

2. Contact Renishaw plc for details on cables (analog 1 Vp-p output, D-sub 15-pin, male) from Renishaw plc. However, the BID and DIR signals are not connected.

3. Use the Linear Encoder connector to change the origin position specifications of the Linear Encoder.

4. The phase U, V, and W inputs are internally pulled up with 10 kΩ.

9.4.4 Analog Signal Input Timing

Input the analog signals with the timing shown in the following figure.

The /cos and /sin signals are the differential signals when the cos and sin signals are shifted 180°. The specifications of the cos, /cos, sin, and /sin signals are identical except for the phases.

The Ref and /Ref signals are input to the comparator. Input a signal that will exceed the hysteresis of the comparator (i.e., the broken lines in the following figure).

When they are crossed, the output data will be counted up.

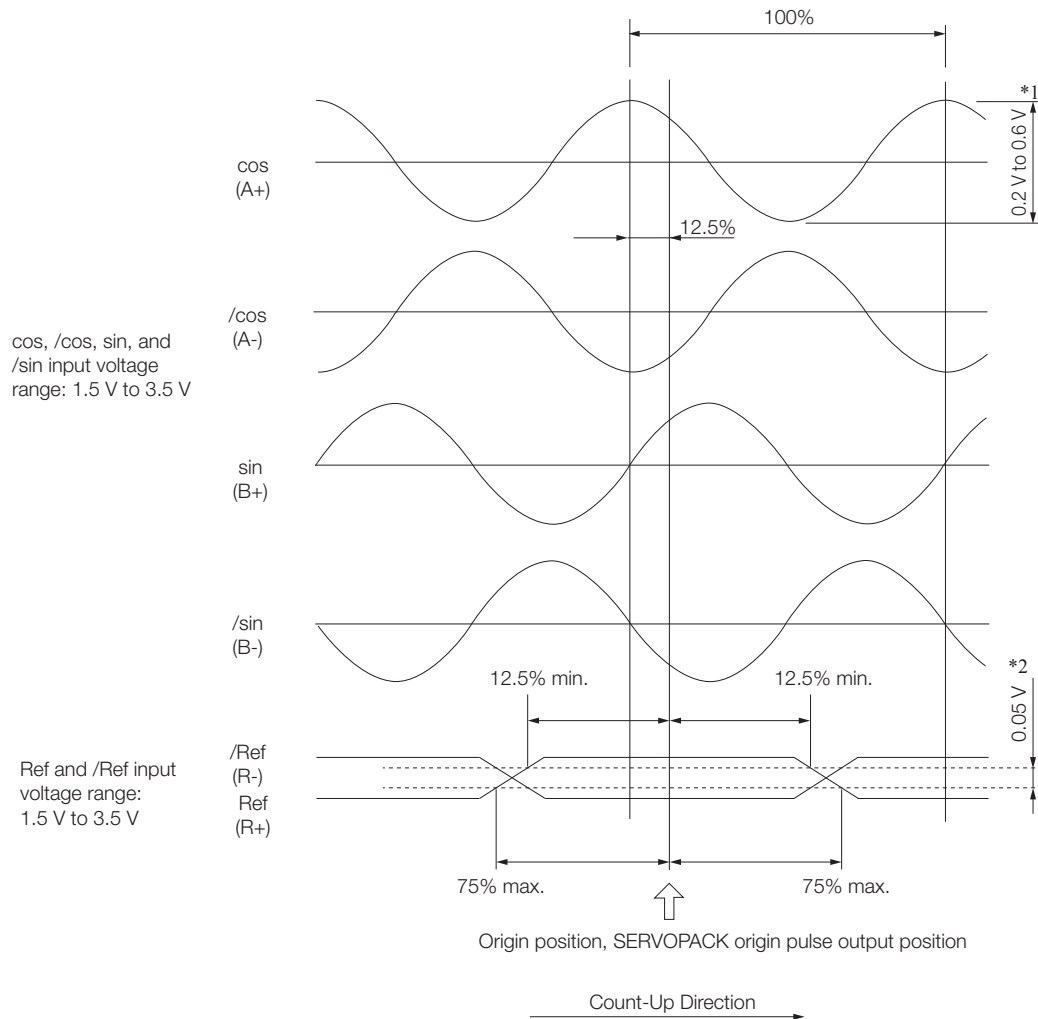

*1. If the analog signal amplitude declines to approximately 0.35 V because of the differential amplitude, the Serial Converter Unit will output an alarm.

*2. This is the hysteresis width.



Important

Application Precautions

1. Never perform insulation resistance or withstand voltage tests.
2. When analog signals are input to the Serial Converter Unit, they are very weak signals, and therefore noise influence on the analog signals affects the Unit's ability to output correct position information. Keep the analog signal cable as short as possible and implement proper shielding.
3. Use the Serial Converter Unit in a location without gases such as H₂S.
4. Do not replace the Unit while power is being supplied. There is a risk of device damage.
5. If you use more than one axis, use a shielded cable for each axis. Do not use one shielded cable for multiple axes.
6. If you use any Linear Encoder other than a recommended Linear Encoder, evaluate the system in advance before you use it.

Cables and User-Assembled Wiring Materials for SERVOPACKs

10

10.1	System Configuration Diagrams and Selection Tables ..	10-3
10.1.1	Cable Configurations	10-3
10.1.2	Selection Table	10-6
10.2	Analog Monitor Cables	10-10
10.3	Digital Operator	10-11
10.3.1	Digital Operator for Σ -7-Series SERVOPACKs: JUSP-OP05A-1-E	10-11
10.3.2	Digital Operator Conversion Cable (for Σ -III-Series Digital Operators)	10-12
10.3.3	Digital Operator Conversion Cable with Lock Screws	10-12
10.3.4	Communications Unit	10-13
10.4	Computer Cable	10-14
10.5	I/O Signal Cables for SERVOPACKs	10-15
10.5.1	For Σ -7S Analog Voltage/Pulse Train Reference SERVOPACKs	10-15
10.5.2	For Σ -7S MECHATROLINK-II/-III Communications Reference or Command Option Attachable-Type SERVOPACKs	10-18
10.5.3	For Σ -7W SERVOPACKs	10-21
10.5.4	For Servo Section of Σ -7C SERVOPACKs	10-24
10.5.5	For Controller Section of Σ -7C SERVOPACKs ...	10-27
10.6	Safety Function Device Cable	10-30
10.6.1	Cables with Connectors	10-30
10.6.2	Connector Kits	10-30
10.7	MECHATROLINK-II Communications Cable ..	10-31

10.8	MECHATROLINK-III Communications Cable . .	10-32
10.9	MECHATROLINK-4 Communications Cable . .	10-33
10.10	Cables to Connect to MP3000/MP2000-Series Machine Controllers . .	10-34
	10.10.1 Cables to Connect to SVA-01 Analog Output Motion Modules	10-34
10.11	I/O Signal Cables for INDEXER Modules . .	10-35
	10.11.1 Cables with Loose Wires at One End	10-35
	10.11.2 Connector Kits	10-36
	10.11.3 Cables with Terminal Block on One End	10-38
10.12	Serial Command Cables (Connector Kit Only) . .	10-39
10.13	DeviceNet Communications Cable	10-40

10.1 System Configuration Diagrams and Selection Tables

10.1.1 Cable Configurations

■ Σ -7S (Single Axis) SERVOPACKs with Analog Voltage/Pulse Train Reference

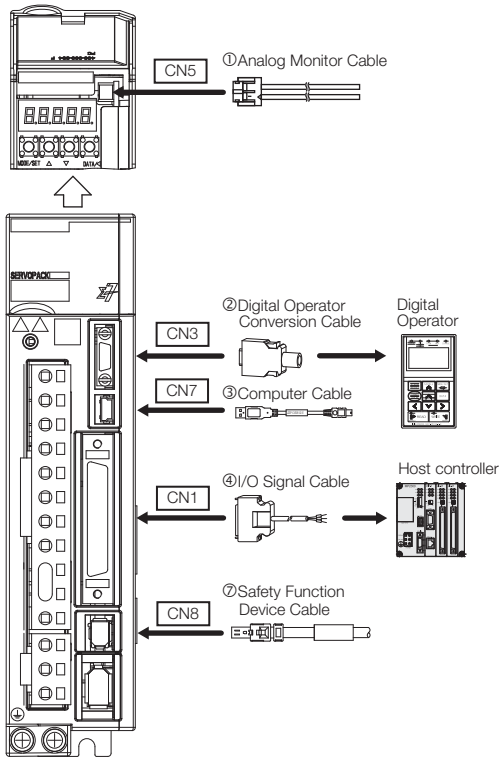

■ Σ -7S (Single Axis) SERVOPACKs with MECHATROLINK-II Communications Reference

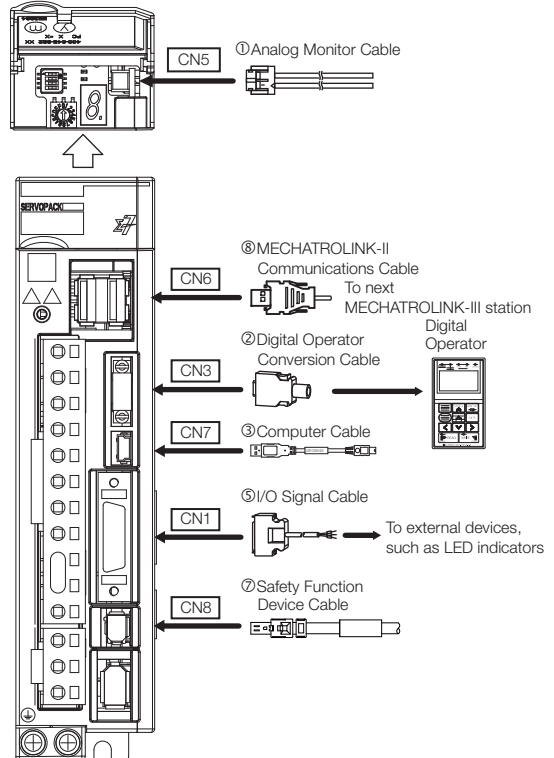

■ Σ -7S (Single Axis) SERVOPACKs with MECHATROLINK-III Communications Reference

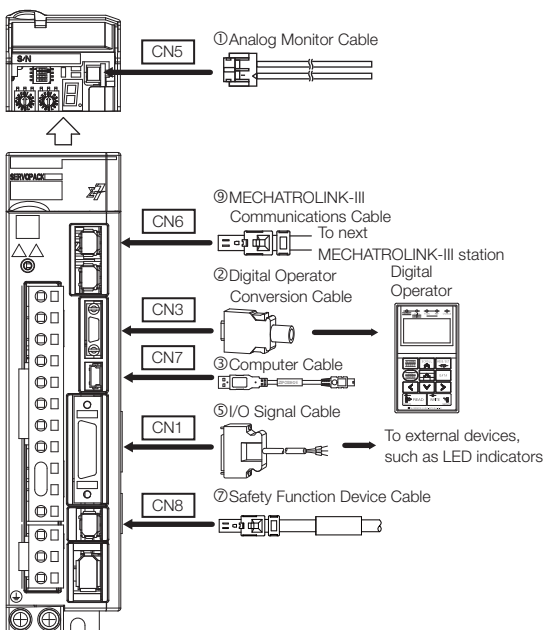

■ Σ -7W (Two Axes) SERVOPACKs with MECHATROLINK-III Communications Reference

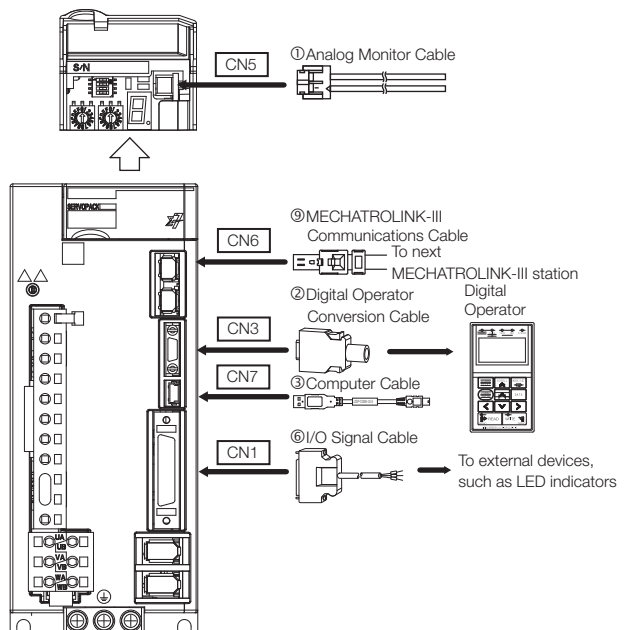

Cables and User-Assembled Wiring Materials for SERVOPACKS

10.1 System Configuration Diagrams and Selection Tables

10.1.1 Cable Configurations

■ Σ -7S (Single Axis) SERVOPACKs with MECHATROLINK-4 Communications Reference

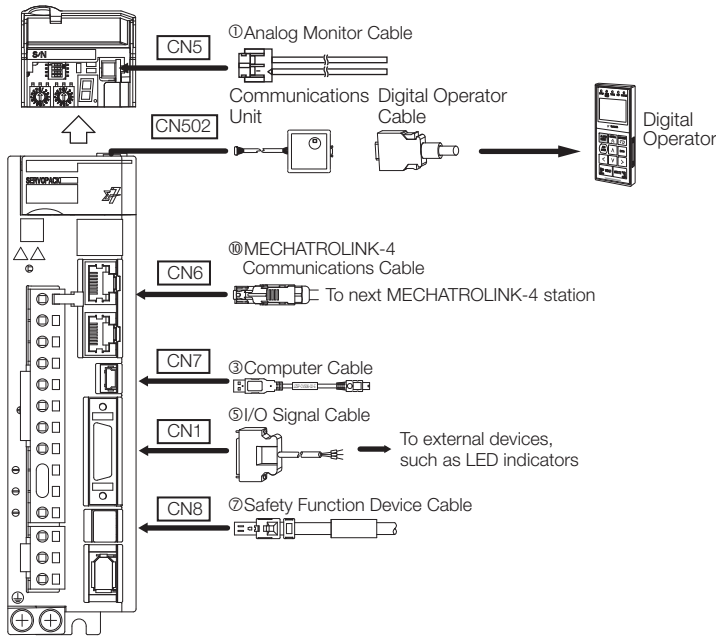

■ Σ -7C (Two Axes with Built-in Controller) SERVOPACKs with Bus Connection Reference

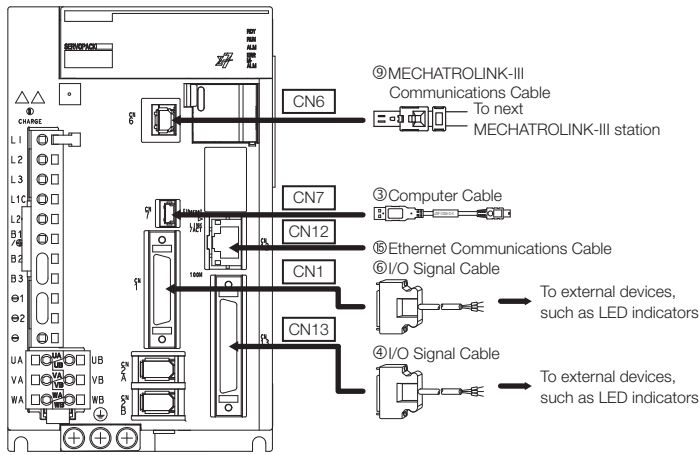

■ Σ -7S (Single Axis) Command Option Attachable-Type SERVOPACKs

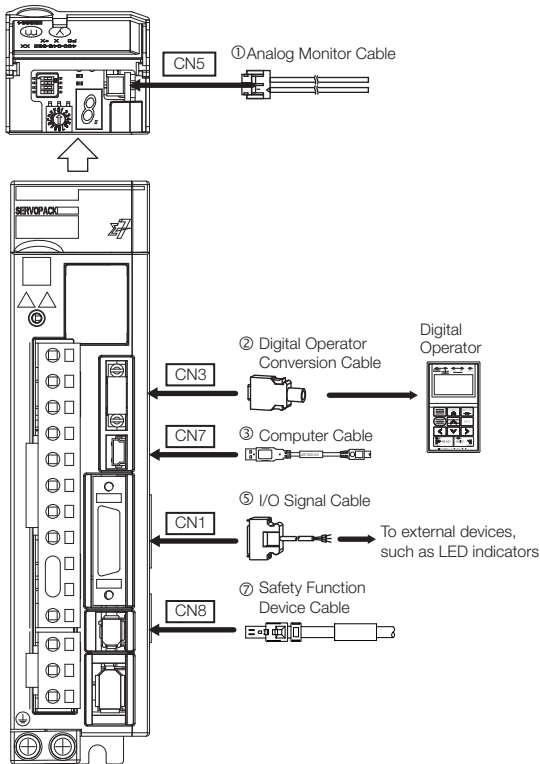

■ Option Module: Safety Module

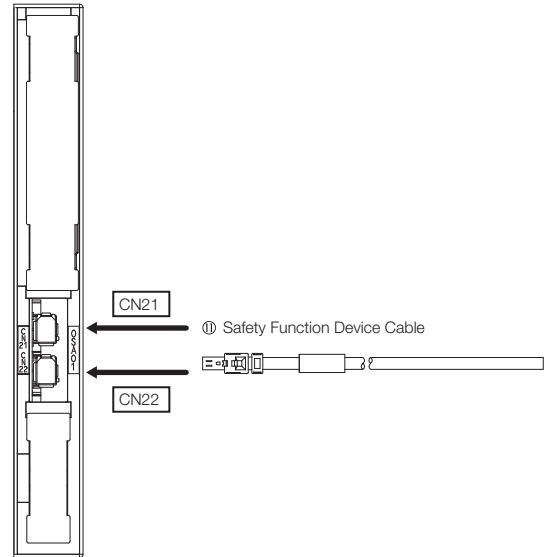

■ Command Option Module: INDEXER Module

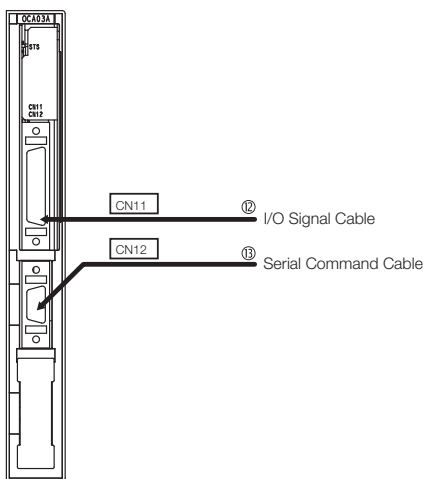



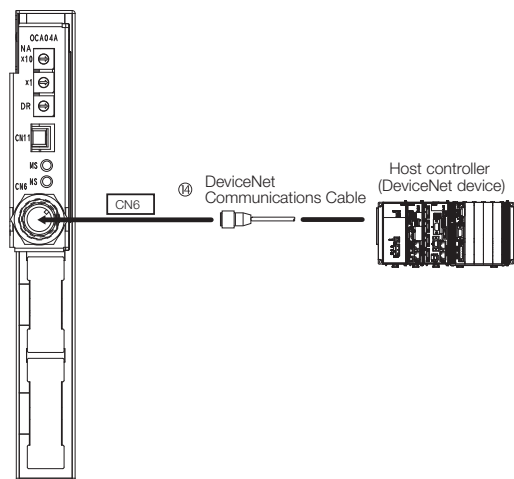



■ Command Option Module: DeviceNet Module

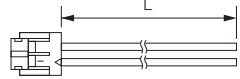
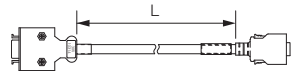
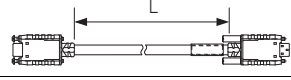
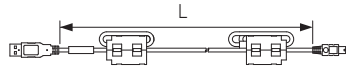

10.1.2 Selection Table

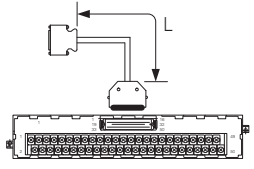
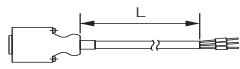

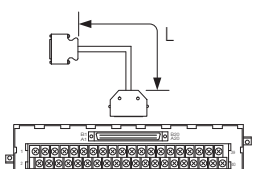

1. Use the cable specified by Yaskawa for the Computer Cable. Operation may not be dependable with any other cable.
2. Use the cable specified by Yaskawa for the MECHATROLINK Communications Cables. Operation may not be dependable due to low noise resistance with any other cable.

Code	Name	Length (L)	Order Number	Appearance	
①	Analog Monitor Cable	1 m	JZSP-CA01-E		
②	Digital Operator Converter Cable	0.3 m	JZSP-CVS05-A3-E*1		
			JZSP-CVS07-A3-E*2		
③	Computer Cable	2.5 m	JZSP-CVS06-02-E		
④	I/O Signal Cables	Soldered Connector Kit	JZSP-CSI9-1-E		
		Connector-Terminal Block Converter Unit (with cable)	0.5 m	JUSP-TA50PG-E	
			1 m	JUSP-TA50PG-1-E	
			2 m	JUSP-TA50PG-2-E	
		Cable with Loose Wires at One End (loose wires on peripheral device end)	1 m	JZSP-CSI01-1-E	
			2 m	JZSP-CSI01-2-E	
			3 m	JZSP-CSI01-3-E	
⑤	I/O Signal Cables	Soldered Connector Kit	JZSP-CSI9-2-E		
		Connector-Terminal Block Converter Unit (with cable)	0.5 m	JUSP-TA26P-E	
			1 m	JUSP-TA26P-1-E	
			2 m	JUSP-TA26P-2-E	
		Cable with Loose Wires at One End (loose wires on peripheral device end)	1 m	JZSP-CSI02-1-E	
			2 m	JZSP-CSI02-2-E	
			3 m	JZSP-CSI02-3-E	

Continued on next page.

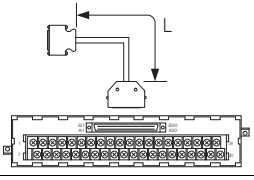
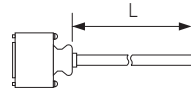
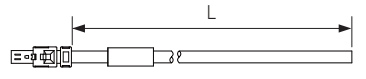
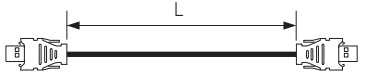
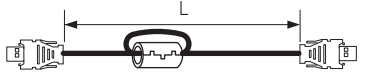
Continued from previous page.

Code	Name	Length (L)	Order Number	Appearance		
⑥	I/O Signal Cables	Soldered Connector Kit	DP9420007-E			
		Connector-Terminal Block Converter Unit (with cable)	0.5 m	JUSP-TA36P-E		
			1 m	JUSP-TA36P-1-E		
			2 m	JUSP-TA36P-2-E		
		Cable with Loose Wires at One End (loose wires on peripheral device end)	1 m	JZSP-CSI03-1-E		
			2 m	JZSP-CSI03-2-E		
			3 m	JZSP-CSI03-3-E		
⑦	Safety Function Device Cable	Cables with Connectors*3	1 m 3 m	JZSP-CVH03-01-E JZSP-CVH03-03-E		
		Connector Kit*4	Contact TE Connectivity Japan G.K. Product name: Industrial Mini I/O D-shape Type 1 Plug Connector Kit Model number: 2013595-1			
⑧	MECHATRO LINK-II Communications Cables	Cables with Connectors on Both Ends	0.5 m	JEPMC-W6002-A5-E		
			1 m	JEPMC-W6002-01-E		
			3 m	JEPMC-W6002-03-E		
			5 m	JEPMC-W6002-05-E		
			10 m	JEPMC-W6002-10-E		
			20 m	JEPMC-W6002-20-E		
			30 m	JEPMC-W6002-30-E		
			40 m	JEPMC-W6002-40-E		
			50 m	JEPMC-W6002-50-E		
		Cables with Connectors on Both Ends (with ferrite cores)	0.5 m	JEPMC-W6003-A5-E		
			1 m	JEPMC-W6003-01-E		
			3 m	JEPMC-W6003-03-E		
			5 m	JEPMC-W6003-05-E		
			10 m	JEPMC-W6003-10-E		
			20 m	JEPMC-W6003-20-E		
			30 m	JEPMC-W6003-30-E		
			40 m	JEPMC-W6003-40-E		
		50 m	JEPMC-W6003-50-E			
		Terminators			JEPMC-W6022-E	

Continued on next page.

Continued from previous page.

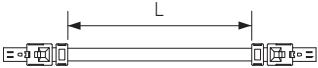
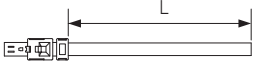
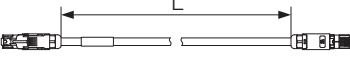
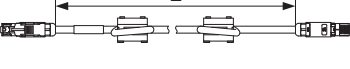
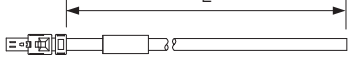
Code	Name	Length (L)	Order Number	Appearance	
⑨	MECHATRO LINK-III Communications Cables	Cables with Connectors on Both Ends	0.2 m	JEPMC-W6012-A2-E	
			0.5 m	JEPMC-W6012-A5-E	
			1 m	JEPMC-W6012-01-E	
			2 m	JEPMC-W6012-02-E	
			3 m	JEPMC-W6012-03-E	
			4 m	JEPMC-W6012-04-E	
			5 m	JEPMC-W6012-05-E	
			10 m	JEPMC-W6012-10-E	
			20 m	JEPMC-W6012-20-E	
			30 m	JEPMC-W6012-30-E	
			50 m	JEPMC-W6012-50-E	
			Cables with Connectors on Both Ends (with core)	10 m	
	20 m	JEPMC-W6013-20-E			
	30 m	JEPMC-W6013-30-E			
	50 m	JEPMC-W6013-50-E			
	Cable with Loose Wires at One End	0.5 m	JEPMC-W6014-A5-E		
		1 m	JEPMC-W6014-01-E		
		3 m	JEPMC-W6014-03-E		
		5 m	JEPMC-W6014-05-E		
10 m		JEPMC-W6014-10-E			
30 m		JEPMC-W6014-30-E			
50 m	JEPMC-W6014-50-E				
⑩	MECHATRO LINK-4 Communications Cables	Cables with Connectors on Both Ends	0.2 m	JZSP-CM3RRM0-00P2-E	
			0.5 m	JZSP-CM3RRM0-00P5-E	
			1 m	JZSP-CM3RRM0-01-E	
			2 m	JZSP-CM3RRM0-02-E	
			3 m	JZSP-CM3RRM0-03-E	
			4 m	JZSP-CM3RRM0-04-E	
			5 m	JZSP-CM3RRM0-05-E	
			10 m	JZSP-CM3RRM0-10-E	
			30 m	JZSP-CM3RR00-30-E	
	Cables with Connectors on Both Ends (with ferrite cores)	0.3 m	JZSP-CM3RRM1-00P3-E		
		3 m	JZSP-CM3RRM1-03-E		
		10 m	JZSP-CM3RRM1-10-E		
		20 m	JZSP-CM3RR01-20-E		
		30 m	JZSP-CM3RR01-30-E		
		50 m	JZSP-CM3RR01-50-E		
⑪	Safety Function Device Cables	Cables with Connectors* ³	1 m	JZSP-CVH03-01-E	
			3 m	JZSP-CVH03-03-E	
		Connector Kit* ⁴	Contact TE Connectivity Japan G.K. Product name: Industrial Mini I/O D-shape Type 1 Plug Connector Kit Model number: 2013595-1		

Continued on next page.

Continued from previous page.

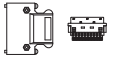
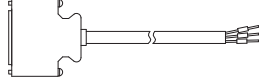
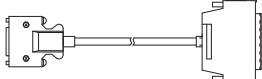
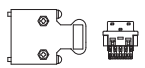
Code	Name		Length (L)	Order Number	Appearance
⑫	I/O Signal Cables	Connector Kit		DP9420007-E	
		Cables with Loose Wires at One End	1 m	JZSP-CVI01-1-E	
			2 m	JZSP-CVI01-2-E	
			3 m	JZSP-CVI01-3-E	
		Cables with Terminal Block on One End	0.5 m	JUSP-TA36V-E	
			1 m	JUSP-TA36V-1-E	
2 m	JUSP-TA36V-2-E				
⑬	Serial Command Cable	Connector Kit*4		JZSP-CHI9-1	Contact your Yaskawa representative for the cable. 
⑭	DeviceNet Communications Cable			The communications cable must be an ODVA-Compliant DeviceNet communications cable. We recommend the following Cable. OMRON DCA1-5CN02F1 Cable with Connectors or the equivalent.	
⑮	Ethernet Communications Cable			Use a commercially available cable that satisfies the following conditions. <ul style="list-style-type: none"> • Ethernet type: 100Base-TX • Category 5 or higher • Twisted-pair cable with RJ-45 connector 	

*1. This Converter Cable is required to use the Σ-III-series Digital Operator (JUSP-OP05A) for Σ-7-series SERVOPACKs.

*2. This Converter Cable is required to prevent the cable from disconnecting from the Digital Operator.

*3. When using safety functions, connect this Cable to the safety function devices.
When not using safety functions, connect the enclosed Safety Jumper Connector (JZSP-CVH05-E) to the SERVOPACK.

*4. Use the Connector Kit when you make cables yourself.

10.2 Analog Monitor Cables

Selection Table

Order Number	Length (L)	Inquires
JZSP-CA01-E	1 m	Yaskawa representative

Dimensional Drawing

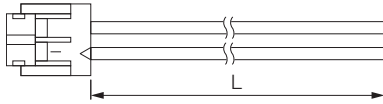

- Wire size: AWG24
- Socket model: DF11-4DS-2C (Hirose Electric Co., Ltd.)
- Contacts model: DF11-2428SCF (Hirose Electric Co., Ltd.)

Wiring Specifications

Pin	Signal	Wire Color	Monitor Contents
1	Analog monitor 2	Red	Select the signal to monitor by setting Pn007 = n.□□XX (Analog Monitor 2 Signal Selection).
2	Analog monitor 1	White	Select the signal to monitor by setting Pn006 = n.□□XX (Analog Monitor 1 Signal Selection).
3	GND (0 V)	Black	Signal ground
4	GND (0 V)	Black	Signal ground

10.3 Digital Operator

A Digital Operator is used to display and set parameters in a SERVOPACK.

You can use the following two types of Digital Operators with Σ -7-Series SERVOPACKs.

- Digital Operator for Σ -V-Series and Σ -7-Series SERVOPACKs: JUSP-OP05A-1-E
- Digital Operators for Σ -III-Series SERVOPACKs: JUSP-OP05A and JUSP-OP05A-E



Important

Use the Yaskawa-specified cables.
Operation will not be dependable due to low noise resistance with any other cable.

10.3.1 Digital Operator for Σ -7-Series SERVOPACKs: JUSP-OP05A-1-E

To use the Digital Operator for Σ -7-Series SERVOPACKs (JUSP-OP05A-1-E), connect it to the CN3 connector on the SERVOPACK.

Main Functions

- Changing and accessing the settings of parameters in the SERVOPACK
- Reading, writing, and verifying the settings of parameters in the SERVOPACK
- Operating the SERVOPACK
- Adjustment with SERVOPACK utility functions
- Monitoring the operating conditions of the SERVOPACK

Selection Table

Order Number	Accessories	Inquiries
JUSP-OP05A-1-E	Cable (1 m)	Yaskawa representative

Dimensional Drawing

- JUSP-OP05A-1-E

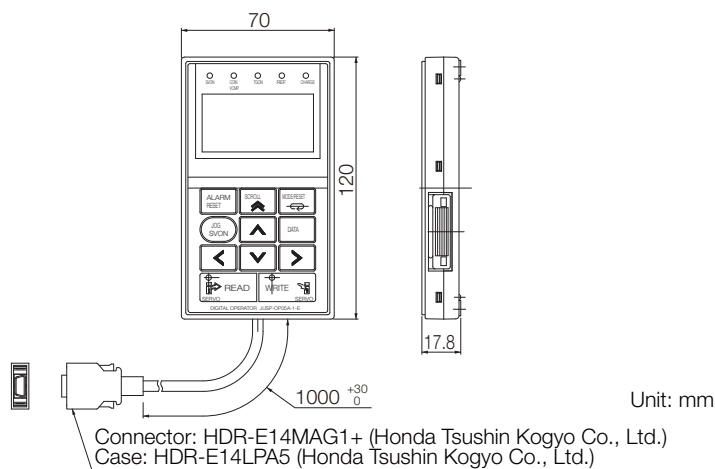

10.3.2 Digital Operator Conversion Cable (for Σ -III-Series Digital Operators)

This Converter Cable is required to use the Σ -III-series Digital Operator (JZSP-OP05A) for Σ -7-series SERVOPACKs.

Selection Table

Order Number	Length (L)	Inquires
JZSP-CVS05-A3-E	0.3 m	Yaskawa representative

Dimensional Drawing

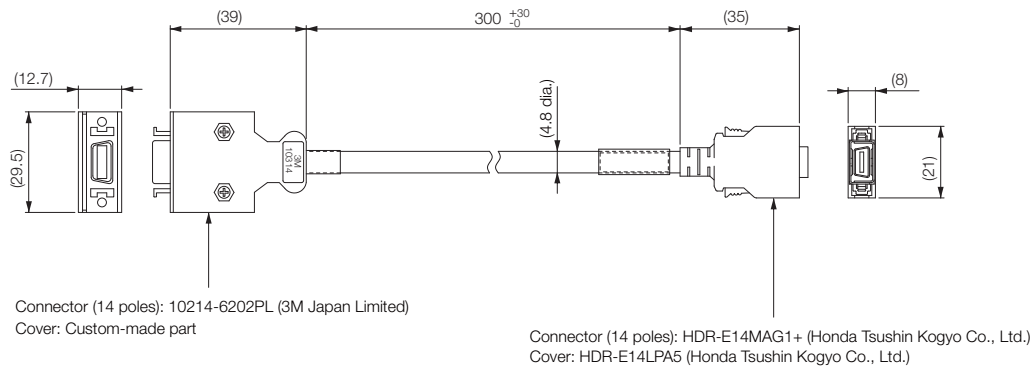

Unit: mm

10.3.3 Digital Operator Conversion Cable with Lock Screws

This Converter Cable is required to prevent the cable from disconnecting from the Digital Operator.

Selection Table

Order Number	Length (L)	Inquires
JZSP-CVS07-A3-E	0.3 m	Yaskawa representative

Dimensional Drawing

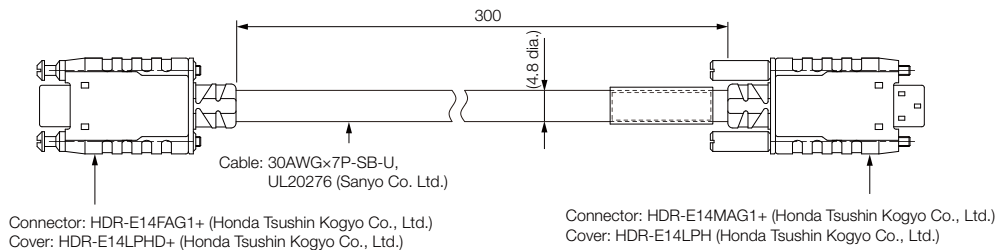

Unit: mm

10.3.4 Communications Unit

To connect the Digital Operator to a SERVOPACK with MECHATROLINK-4 Communications References, connect the Digital Operator to CN502 on the SERVOPACK. A JUSP-JC001-1 Communications Unit is required to make the connection.

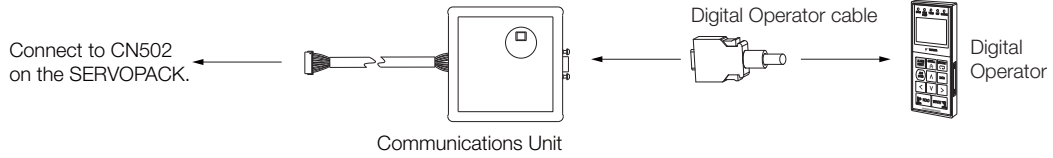

Communications Unit

Item	Description
Inquiries	Your Yaskawa representative
Order Number	JUSP-JC001-1
External Dimensions	<p>CN53: ZHR-8 J.S.T. Mfg. Co., Ltd.</p> <p>CN3: HDR-EC14LFDTN-SLE-PLUS Honda Tsushin Kogyo Co., Ltd.</p> <p>66.5</p> <p>67</p> <p>4</p> <p>71</p> <p>302</p> <p>28</p> <p>Approx. mass: 0.08 kg Unit: mm</p>

10.4 Computer Cable



Use the Yaskawa-specified cable for the Computer Cable. Operation will not be dependable with any other cable.

Selection Table

Order Number	Length (L)	Inquires
JZSP-CVS06-02-E	2.5 m	Yaskawa representative

Dimensional Drawing

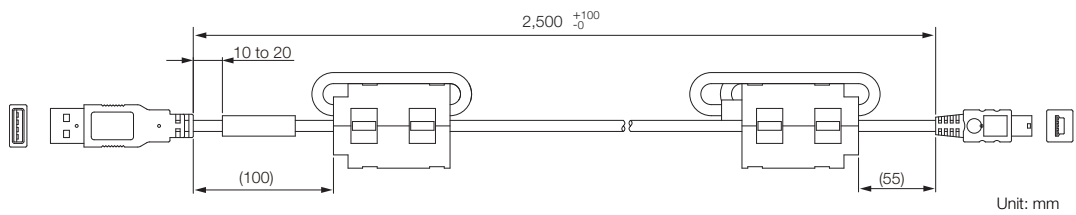

10.5 I/O Signal Cables for SERVOPACKs

10.5.1 For Σ -7S Analog Voltage/Pulse Train Reference SERVOPACKs

Cable with Loose Wires at One End

◆ Selection Table

Order Number	Length (L)	Inquires
JZSP-CSI01-1-E	1 m	Yaskawa representative
JZSP-CSI01-2-E	2 m	
JZSP-CSI01-3-E	3 m	

◆ Dimensional Drawing

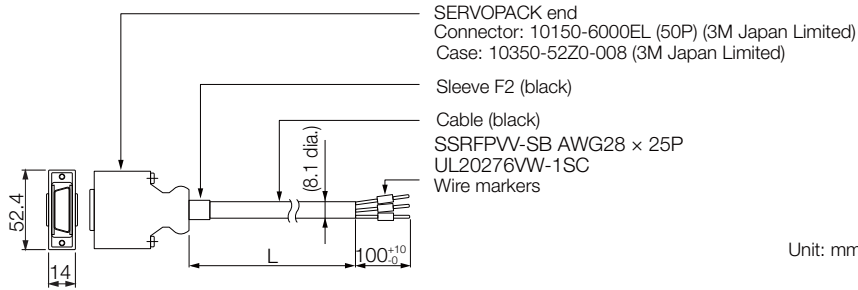

◆ Wiring Specifications

Pin	SERVOPACK end			Markings		Host controller end	Wire Marker No.
	Signal*	Wire Color	Color	Qty			
1	SG	Orange	Red	1			1
3	PL1	Orange	Black	1			3
2	SG	Gray	Red	1			2
4	SEN	Gray	Black	1			4
5	V-REF	White	Red	1			5
6	SG	White	Black	1			6
7	PULS	Yellow	Red	1			7
8	/PULS	Yellow	Black	1			8
9	T-REF	Pink	Red	1			9
10	SG	Pink	Black	1			10
11	SIGN	Orange	Red	2			11
12	/SIGN	Orange	Black	2			12
13	PL2	Gray	Red	2			13
14	/CLR	White	Red	2			14
15	CLR	White	Black	2			15
16	-	Gray	Black	2			16
17	-	Yellow	Red	2			17
18	PL3	Yellow	Black	2			18
19	PCO	Pink	Red	2			19
20	/PCO	Pink	Black	2			20
21	BAT+	Orange	Red	3			21
22	BAT-	Orange	Black	3			22
23	-	Gray	Red	3			23
24	-	Gray	Black	3			24
25	/S01+ (/V-CMP+ or /COIN+)	White	Red	3			25
26	/S01- (/V-CMP- or /COIN-)	White	Black	3			26
27	/S02+ (/TGON+)	Yellow	Red	3			27
28	/S02- (/TGON-)	Yellow	Black	3			28
29	/S03+ (/S-RDY+)	Pink	Red	3			29
30	/S03- (/S-RDY-)	Pink	Black	3			30
31	ALM+	Orange	Red	4			31
32	ALM-	Orange	Black	4			32
33	PAO	Gray	Red	4			33
34	/PAO	Gray	Black	4			34
35	PBO	White	Red	4			35
36	/PBO	White	Black	4			36
37	ALO1	Yellow	Red	4			37
38	ALO2	Yellow	Black	4			38
39	ALO3	Pink	Red	4			39
40	/S10 (/S-ON)	Pink	Black	4			40
41	/S13 (/P-CON)	Orange	Red	5			41
42	/S11 (/P-OT)	Orange	Black	5			42
43	/S12 (/N-OT)	Gray	Red	5			43
44	/S14 (/ALM-RST)	Gray	Black	5			44
45	/S15 (/P-CL)	White	Red	5			45
46	/S16 (/N-CL)	White	Black	5			46
47	+24VIN	Yellow	Red	5			47
48	PSO	Pink	Red	5			48
49	/PSO	Pink	Black	5			49
50	TH	Yellow	Black	5			50
Case	Shield						

⚡ Represents twisted-pair

* The signals to use differ depending on the control method. For details, refer to the manual for your SERVOPACK.

Connector Kits

◆ Selection Table

Connector Kit Order Number	Case		Connectors	
	Model	Qty	Model	Qty
JZSP-CSI9-1-E	10350-52Z0-008 (3M Japan Limited)	1 set	10150-3000PE (soldered) (3M Japan Limited)	1

■ Wire Sizes

Item	Specification
Applicable Wires	AWG24, 26, 28, 30
Cable Finished Diameter	16 mm max.

Note: Use a twisted-pair or screened twisted-pair cable.

◆ Dimensional Drawings

■ Case

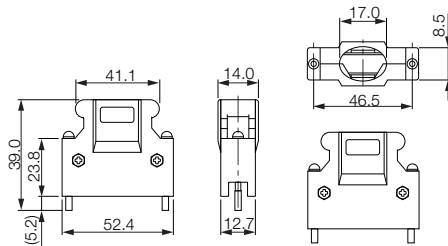

Unit: mm

■ Connectors

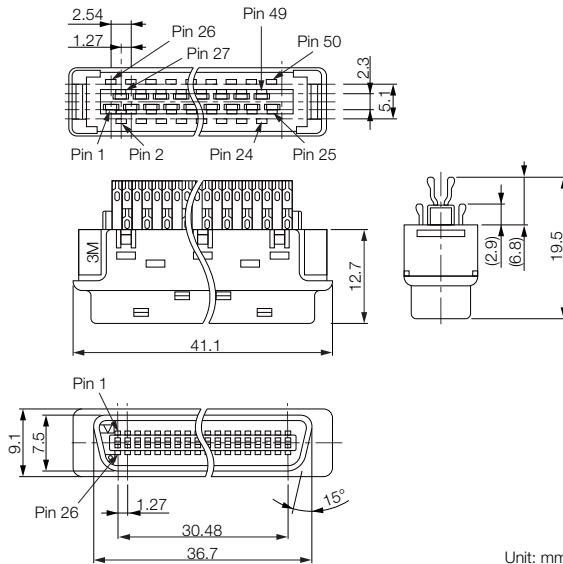

Unit: mm

Connector-Terminal Block Converter Unit

◆ Selection Table

Order Number	Length of Enclosed Cable (L)	Inquires
JUSP-TA50PG-E	0.5 m	Yaskawa representative
JUSP-TA50PG-1-E	1 m	
JUSP-TA50PG-2-E	2 m	

◆ Dimensional Drawing

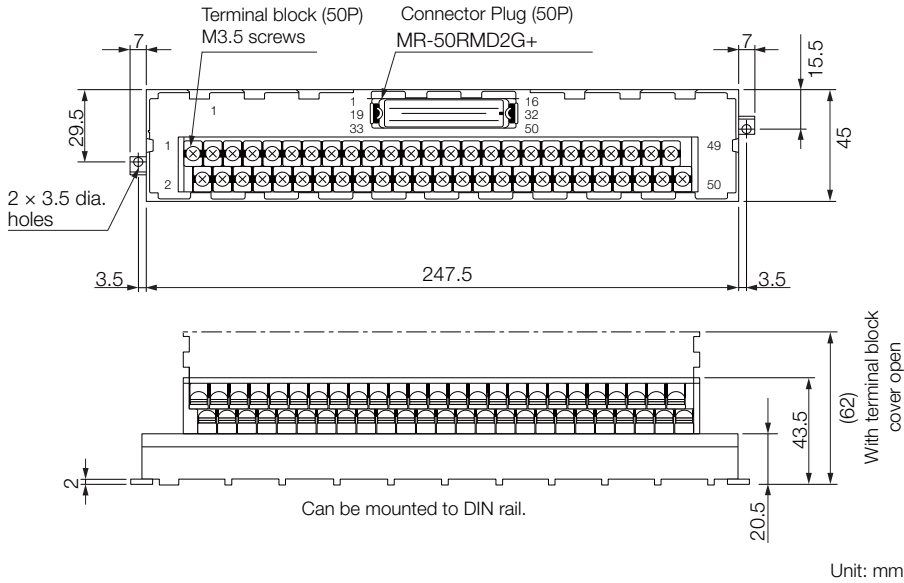

◆ Dimensional Drawing of Enclosed Cable

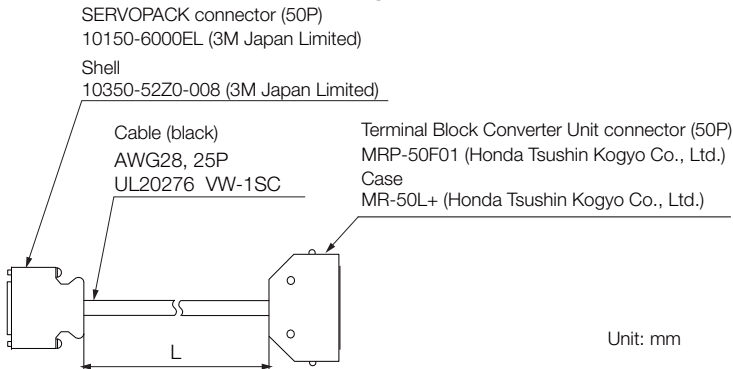

Note: The same pin numbers are used for the SERVOPACK connector and the terminal block. To assemble your own cables, refer to the following section for the wiring specifications.

◆ **Wiring Specifications** on page 10-15

10.5.2 For Σ -7S MECHATROLINK-II/-III Communications Reference or Command Option Attachable-Type SERVOPACKS

Cable with Loose Wires at One End

◆ Selection Table

Order Number	Length (L)	Inquires
JZSP-CSI02-1-E	1 m	Yaskawa representative
JZSP-CSI02-2-E	2 m	
JZSP-CSI02-3-E	3 m	

◆ Dimensional Drawing

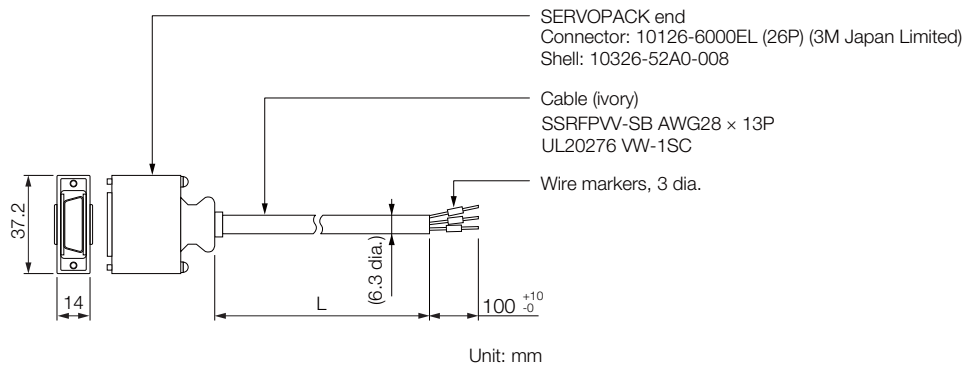

◆ Wiring Specifications

Pin	Signal*	Wire Color	Markings		Wire Marker No.
			Color	Qty	
1	/SO1+ (/BK+)	Blue	Red	1	1
2	/SO1- (/BK-)	Blue	Black	1	2
3	ALM+	Pink	Red	1	3
4	ALM-	Pink	Black	1	4
5	TH	Green	Red	1	5
6	+24VIN	Green	Black	1	6
7	/SI1 (P-OT)	Orange	Red	1	7
8	/SI2 (N-OT)	Orange	Black	1	8
9	/SI3 (/DEC)	Gray	Red	1	9
10	/SI4 (/EXT1)	Gray	Black	1	10
11	/SI5 (/EXT2)	Blue	Red	2	11
12	/SI6 (/EXT3)	Blue	Black	2	12
13	/SI0	Pink	Red	2	13
14	BAT+	Green	Red	2	14
15	BAT-	Green	Black	2	15
16	SG	Pink	Black	2	16
17	PAO	Orange	Red	2	17
18	/PAO	Orange	Black	2	18
19	PBO	Gray	Red	2	19
20	/PBO	Gray	Black	2	20
21	PCO	Blue	Red	3	21
22	/PCO	Blue	Black	3	22
23	/SO2+	Pink	Red	3	23
24	/SO2-	Pink	Black	3	24
25	/SO3+	Green	Red	3	25
26	/SO3-	Green	Black	3	26

∩ : Represents twisted-pair wires.

* These are the signal names in MECHATROLINK-II/-III Communications Reference SERVOPACK. For the signal names in the Command Option Attachable-Type SERVOPACK, refer to the manual for your SERVOPACK.

Connector Kits

◆ Selection Table

Connector Kit Order Number	Case		Connectors	
	Model	Qty	Model	Qty
JZSP-CSI9-2-E	10326-52A0-008 (3M Japan Limited)	1 set	10126-3000PE (soldered) (3M Japan Limited)	1

• Wire Sizes

Item	Specification
Applicable Wires	AWG24, 26, 28, 30
Cable Finished Diameter	16 mm max.

Note: Use a twisted-pair or screened twisted-pair cable.

◆ Dimensional Drawings

■ Case

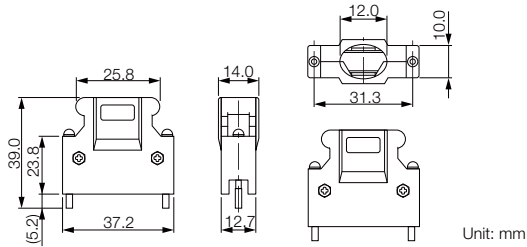

■ Connectors

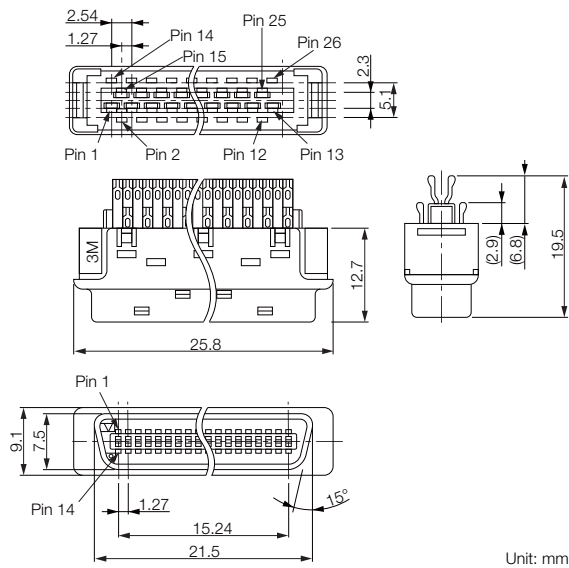

Connector-Terminal Block Converter Unit

◆ Selection Table

Order Number	Length of Enclosed Cable (L)	Inquires
JUSP-TA26P-E	0.5 m	Yaskawa representative
JUSP-TA26P-1-E	1 m	
JUSP-TA26P-2-E	2 m	

◆ Dimensional Drawing

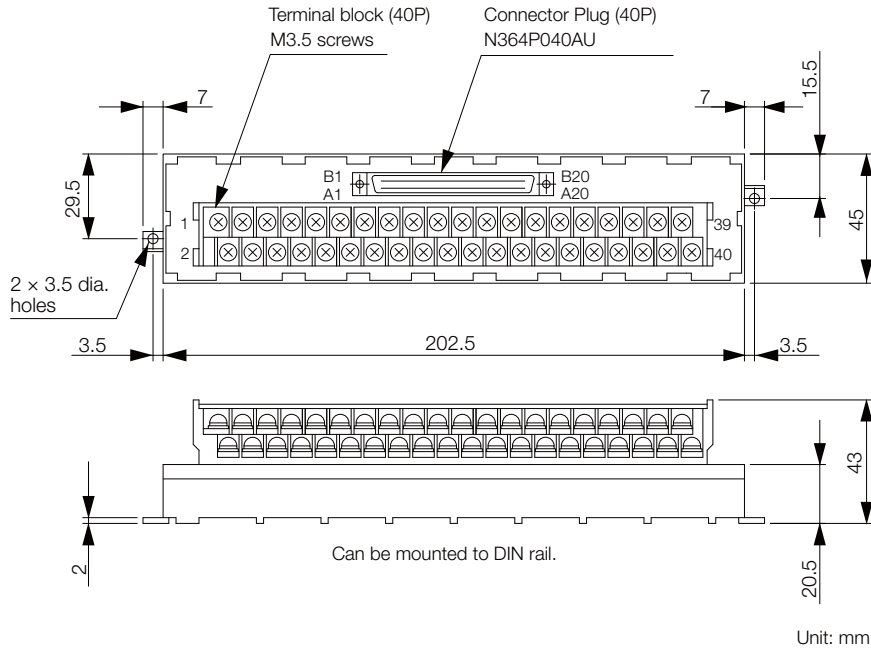

◆ Dimensional Drawing of Enclosed Cable

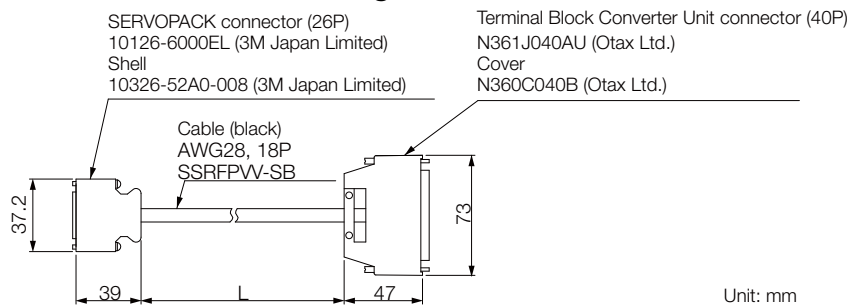

Note: The same pin numbers are used for the SERVOPACK connector and the terminal block. Pins 1 to 26 are wired. Do not connect pins 27 and higher.
To assemble your own cables, refer to the following section for the wiring specifications.

◆ **Wiring Specifications** on page 10-18

10.5.3 For Σ-7W SERVOPACKs

Cable with Loose Wires at One End

◆ Selection Table

Order Number	Length (L)	Inquires
JZSP-CSI03-1-E	1 m	Yaskawa representative
JZSP-CSI03-2-E	2 m	
JZSP-CSI03-3-E	3 m	

◆ Dimensional Drawing

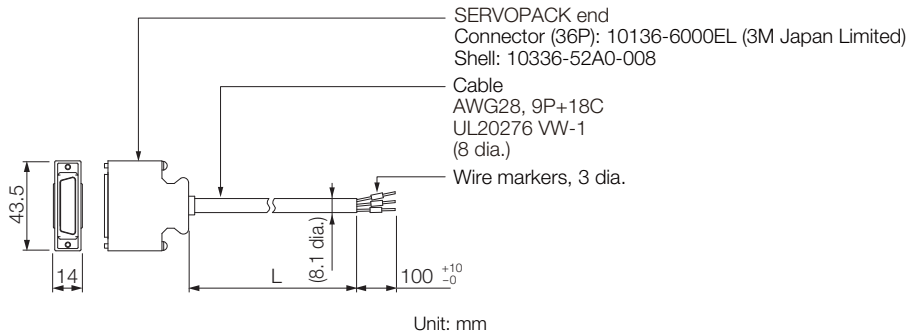

◆ Wiring Specifications

Pin	Signal	Wire Color	Markings		Wire Marker No.
			Color	Qty	
1	+24VIN	Orange	Black	3	1
2	-	Gray	Black	3	2
3	/SI01 (P-OT_A)	White	Black	3	3
4	/SI02 (N-OT_A)	Yellow	Black	3	4
5	/SI03 (/DEC_A)	Pink	Black	3	5
6	/SI04 (/EXT_A1)	Orange	Black	4	6
7	/SI05 (/EXT_A2)	Gray	Black	4	7
8	/SI06 (/EXT_A3)	White	Black	4	8
9	/SI07 (P-OT_B)	Yellow	Black	4	9
10	/SI08 (N-OT_B)	Pink	Black	4	10
11	/SI09 (/DEC_B)	Orange	Black	Continuous dots	11
12	/SI10 (/EXT_B1)	Gray	Black	Continuous dots	12
13	/SI11 (/EXT_B2)	White	Black	Continuous dots	13
14	/SI12 (/EXT_B3)	Yellow	Black	Continuous dots	14
15	SG	Pink	Black	Continuous dots	15
16	SG	Orange	Black	Dashes	16
17	BAT_A+	Orange	Black	1	17
18	BAT_A-	Orange	Red	1	18
19	ALM_A+	Gray	Black	1	19
20	ALM_A-	Gray	Red	1	20
21	ALM_B+	White	Black	1	21
22	ALM_B-	White	Red	1	22
23	/SO1+ (/BK_A+)	Yellow	Black	1	23
24	/SO1- (/BK_A-)	Yellow	Red	1	24
25	/SO2+ (/BK_B+)	Pink	Black	1	25
26	/SO2- (/BK_B-)	Pink	Red	1	26
27	/SO3+	Orange	Black	2	27
28	/SO3-	Orange	Red	2	28
29	/SO4+	Gray	Black	2	29
30	/SO4-	Gray	Red	2	30
31	/SO5+	White	Black	2	31
32	/SO5-	White	Red	2	32
33	TH_A	Gray	Black	Dashes	33
34	TH_B	White	Black	Dashes	34
35	BAT_B+	Yellow	Black	2	35
36	BAT_B-	Yellow	Red	2	36
Case	Shield	-	-	-	-

: Represents twisted-pair wires.

Connector Kits

◆ Selection Table

Connector Kit Order Number	Case		Connectors	
	Model	Qty	Model	Qty
DP9420007-E	10336-52A0-008 (3M Japan Limited)	1 set	10136-3000PE (soldered) (3M Japan Limited)	1

• Wire Sizes

Item	Specification
Applicable Wires	AWG24, 26, 28, 30
Cable Finished Diameter	16 mm max.

Note: Use a twisted-pair or screened twisted-pair cable.

◆ Dimensional Drawings

■ Case

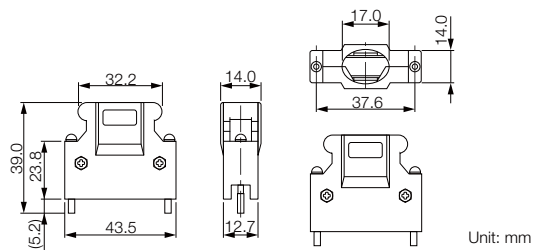

■ Connectors

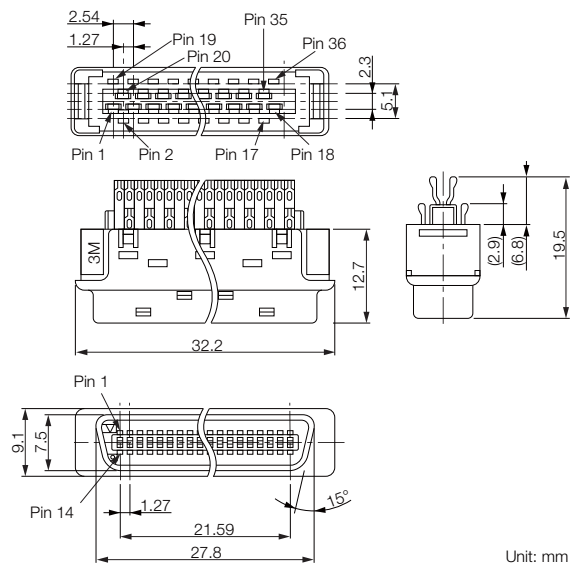

Connector-Terminal Block Converter Unit

◆ Selection Table

Order Number	Length of Enclosed Cable (L)	Inquires
JUSP-TA36P-E	0.5 m	Yaskawa representative
JUSP-TA36P-1-E	1 m	
JUSP-TA36P-2-E	2 m	

◆ Dimensional Drawing

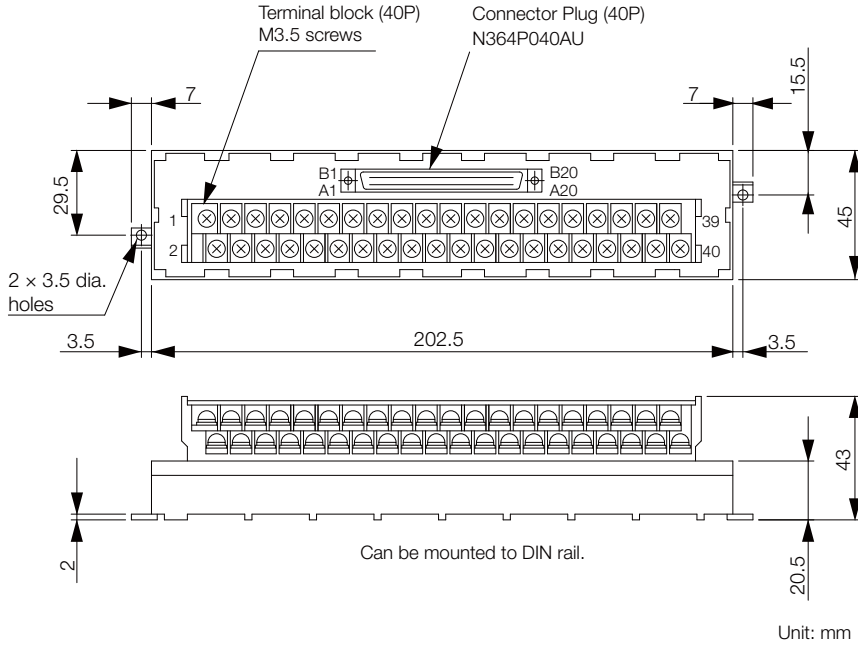

◆ Dimensional Drawing of Enclosed Cable

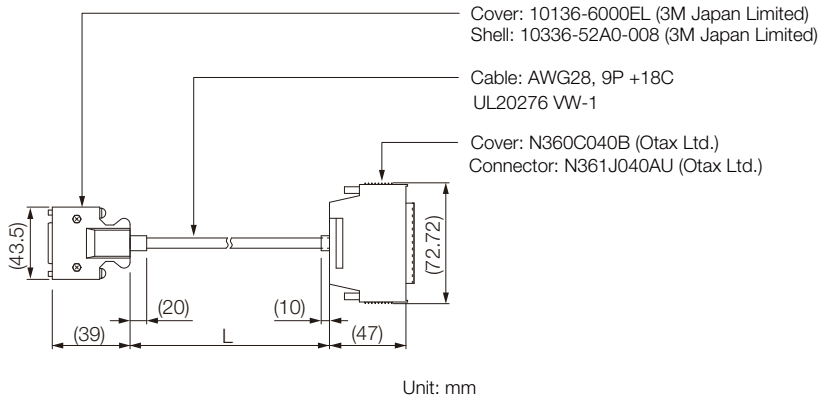

Note: The same pin numbers are used for the SERVOPACK connector and the terminal block. Pins 1 to 36 are wired. Do not connect pins 37 and higher.
To assemble your own cables, refer to the following section for the wiring specifications.

◆ Wiring Specifications on page 10-21

10.5.4 For Servo Section of Σ-7C SERVOPACKS

Cables with Loose Wires at One End

◆ Selection Table

Order Number	Length (L)	Inquiries
JZSP-CSI03-1-E	1 m	Yaskawa representative
JZSP-CSI03-2-E	2 m	
JZSP-CSI03-3-E	3 m	

◆ Dimensional Drawing

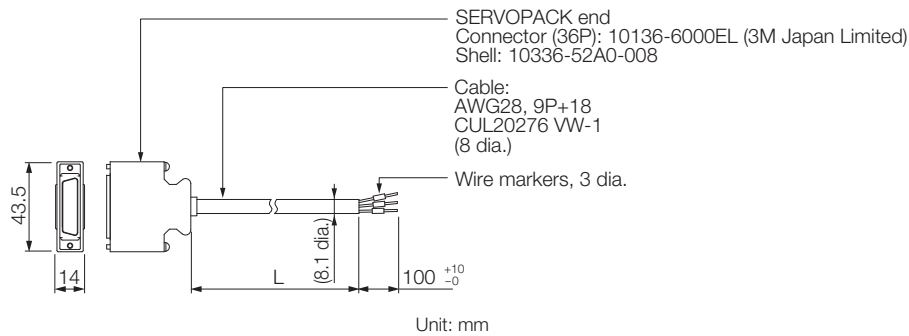

◆ Wiring Specifications

Pin	Signal	Wire Color	Markings		Host controller end	Wire Marker No.
			Color	Qty		
1	+24VIN	Orange	Black	3		1
2	-	Gray	Black	3		2
3	/SI01 (P-OT_A)	White	Black	3		3
4	/SI02 (N-OT_A)	Yellow	Black	3		4
5	/SI03 (/DEC_A)	Pink	Black	3		5
6	/SI04 (/EXT_A1)	Orange	Black	4		6
7	/SI05 (/EXT_A2)	Gray	Black	4		7
8	/SI06 (/EXT_A3)	White	Black	4		8
9	/SI07 (P-OT_B)	Yellow	Black	4		9
10	/SI08 (N-OT_B)	Pink	Black	4		10
11	/SI09 (/DEC_B)	Orange	Black	Continuous dots		11
12	/SI10 (/EXT_B1)	Gray	Black	Continuous dots		12
13	/SI11 (/EXT_B2)	White	Black	Continuous dots		13
14	/SI12 (/EXT_B3)	Yellow	Black	Continuous dots		14
15	SG	Pink	Black	Continuous dots		15
16	SG	Orange	Black	Dashes		16
17	BAT_A+	Orange	Black	1		17
18	BAT_A-	Orange	Red	1		18
19	ALM_A+	Gray	Black	1		19
20	ALM_A-	Gray	Red	1		20
21	ALM_B+	White	Black	1		21
22	ALM_B-	White	Red	1		22
23	/SO1+ (/BK_A+)	Yellow	Black	1		23
24	/SO1- (/BK_A-)	Yellow	Red	1		24
25	/SO2+ (/BK_B+)	Pink	Black	1		25
26	/SO2- (/BK_B-)	Pink	Red	1		26
27	/SO3+	Orange	Black	2		27
28	/SO3-	Orange	Red	2		28
29	/SO4+	Gray	Black	2		29
30	/SO4-	Gray	Red	2		30
31	/SO5+	White	Black	2		31
32	/SO5-	White	Red	2		32
33	TH_A	Gray	Black	Dashes		33
34	TH_B	White	Black	Dashes		34
35	BAT_B+	Yellow	Black	2		35
36	BAT_B-	Yellow	Red	2		36
Case	Shield	-	-	-		

△ : Represents twisted-pair wires.

Connector Kits

◆ Selection Table

Connector Kit Order Number	Case		Connectors	
	Model	Qty	Model	Qty
DP9420007-E	10336-52A0-008 (3M Japan Limited)	1 set	10136-3000PE (soldered) (3M Japan Limited)	1

• Wire Sizes

Item	Specification
Applicable Wires	AWG24, 26, 28, 30
Cable Finished Diameter	16 mm max.

Note: Use a twisted-pair or screened twisted-pair cable.

◆ Dimensional Drawings

■ Case

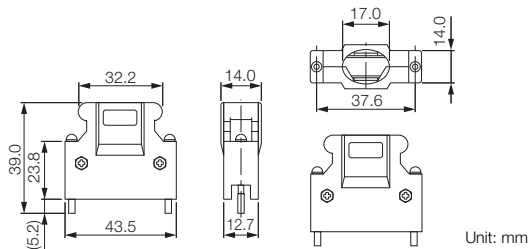

■ Connectors

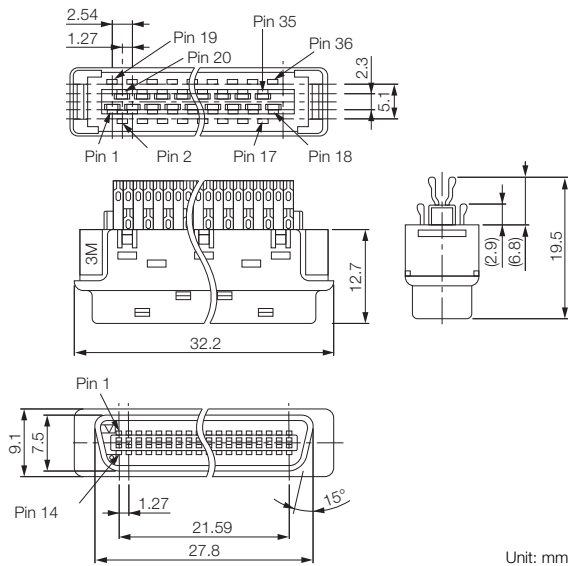

Connector-Terminal Block Converter Unit

◆ Selection Table

Order Number	Length of Enclosed Cable (L)	Inquiries
JUSP-TA36P-E	0.5 m	Yaskawa representative
JUSP-TA36P-1-E	1 m	
JUSP-TA36P-2-E	2 m	

◆ Dimensional Drawing

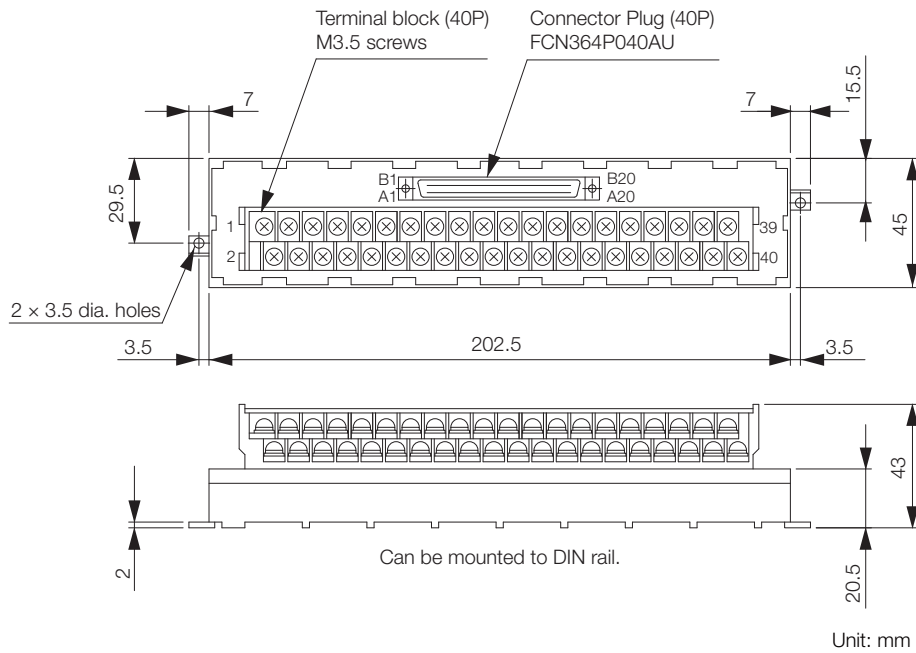

◆ Dimensional Drawing of Enclosed Cable

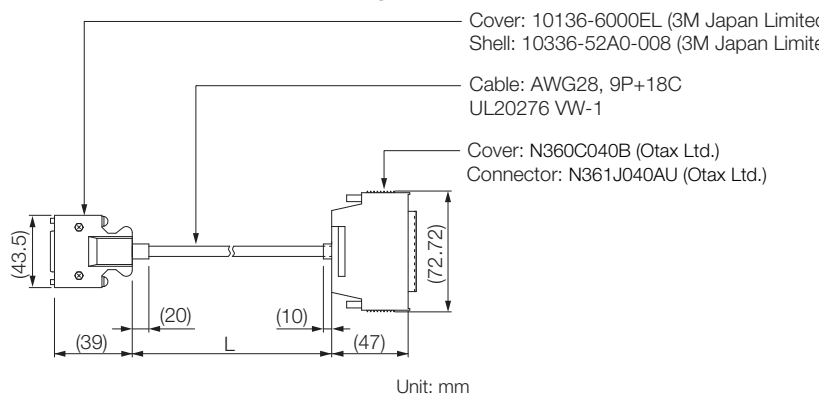

Note: The same pin numbers are used for the SERVOPACK connector and the terminal block. Pins 1 to 36 are wired. Do not connect pins 37 and higher.

To assemble your own cables, refer to the following section for the wiring specifications.

◆ Wiring Specifications on page 10-24

10.5.5 For Controller Section of Σ-7C SERVOPACKs

Cable with Loose Wires at One End

◆ Selection Table

Order Number	Length (L)	Inquiries
JZSP-CSI01-1-E	1 m	Yaskawa representative
JZSP-CSI01-2-E	2 m	
JZSP-CSI01-3-E	3 m	

◆ Dimensional Drawing

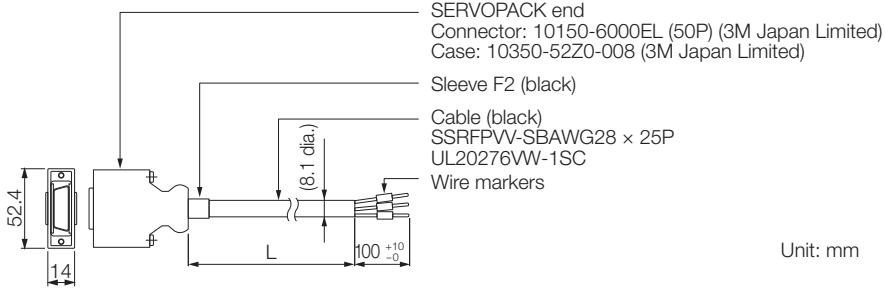

◆ Wiring Specifications

Pin	Signal	SERVOPACK end			Host controller end	Wire Marker No.
		Wire Color	Color	Qty		
1	PA+	Orange	Red	1	1	1
3	GND	Orange	Black	1	3	3
2	PA-	Gray	Red	1	2	2
4	PLIN	Gray	Black	1	4	4
5	PLCOM24V	White	Red	1	5	5
6	DO_GND1	White	Black	1	6	6
7	DO_24V1	Yellow	Red	1	7	7
8	DO_00	Yellow	Black	1	8	8
9	DO_02	Pink	Red	1	9	9
10	DO_04	Pink	Black	1	10	10
11	DO_06	Orange	Red	2	11	11
12	DO_GND2	Orange	Black	2	12	12
13	DO_08	Gray	Red	2	13	13
14	DO_10	White	Red	2	14	14
15	DO_12	White	Black	2	15	15
16	DO_14	Gray	Black	2	16	16
17	DI_00	Yellow	Red	2	17	17
18	DI_02	Yellow	Black	2	18	18
19	DI_04	Pink	Red	2	19	19
20	DI_06	Pink	Black	2	20	20
21	DI_08	Orange	Red	3	21	21
22	DI_10	Orange	Black	3	22	22
23	DI_12	Gray	Red	3	23	23
24	DI_14	Gray	Black	3	24	24
25	DI_COM1	White	Red	3	25	25
26	PB+	White	Black	3	26	26
27	PB-	Yellow	Red	3	27	27
28	GND	Yellow	Black	3	28	28
29	PLCOM5V	Pink	Red	3	29	29
30	PLCOM12V	Pink	Black	3	30	30
31	DO_GND1	Orange	Red	4	31	31
32	DO_01	Orange	Black	4	32	32
33	DO_03	Gray	Red	4	33	33
34	DO_05	Gray	Black	4	34	34
35	DO_07	White	Red	4	35	35
36	DO_GND2	White	Black	4	36	36
37	DO_24V2	Yellow	Red	4	37	37
38	DO_09	Yellow	Black	4	38	38
39	DO_11	Pink	Red	4	39	39
40	DO_13	Pink	Black	4	40	40
41	DO_15	Orange	Red	5	41	41
42	DI_01	Orange	Black	5	42	42
43	DI_03	Gray	Red	5	43	43
44	DI_05	Gray	Black	5	44	44
45	DI_07	White	Red	5	45	45
46	DI_09	White	Black	5	46	46
47	DI_11	Yellow	Red	5	47	47
48	DI_13	Pink	Red	5	48	48
49	DI_15	Pink	Black	5	49	49
50	DI_COM2	Yellow	Black	5	50	50
Case	Shield					

⚡ : Represents twisted-pair wires.

Connector Kits

◆ Selection Table

Connector Kit Order Number	Case		Connectors	
	Model	Qty	Model	Qty
JZSP-CS19-1-E	10350-52Z0-008 (3M Japan Limited)	1 set	10150-3000PE (soldered) (3M Japan Limited)	1

■ Wire Sizes

Item	Specification
Applicable Wires	AWG24, 26, 28, 30
Cable Finished Diameter	16 mm max.

Note: Use a twisted-pair or screened twisted-pair cable.

◆ Dimensional Drawings

■ Case

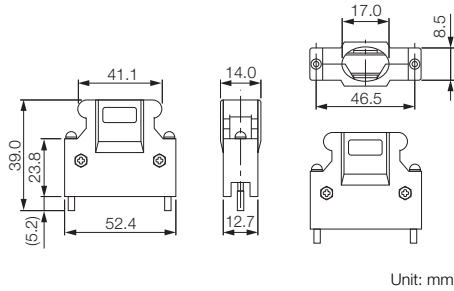

■ Connectors

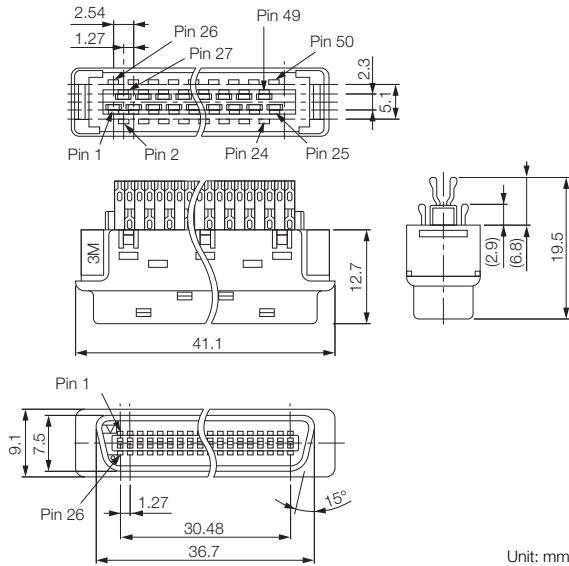

Connector-Terminal Block Converter Unit

◆ Selection Table

Order Number	Length of Enclosed Cable (L)	Inquiries
JUSP-TA50PG-E	0.5 m	Yaskawa representative
JUSP-TA50PG-1-E	1 m	
JUSP-TA50PG-2-E	2 m	

◆ Dimensional Drawing

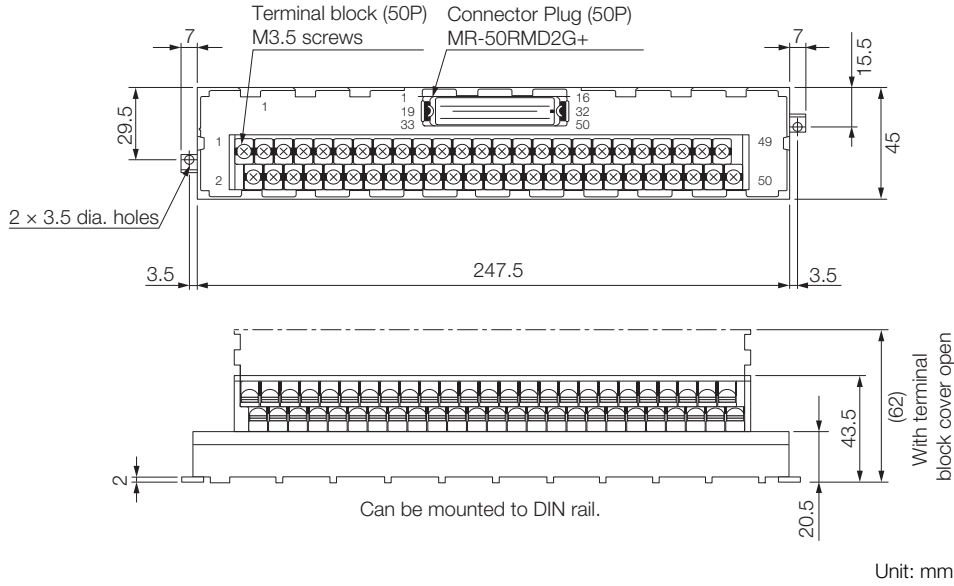

◆ Dimensional Drawing of Enclosed Cable

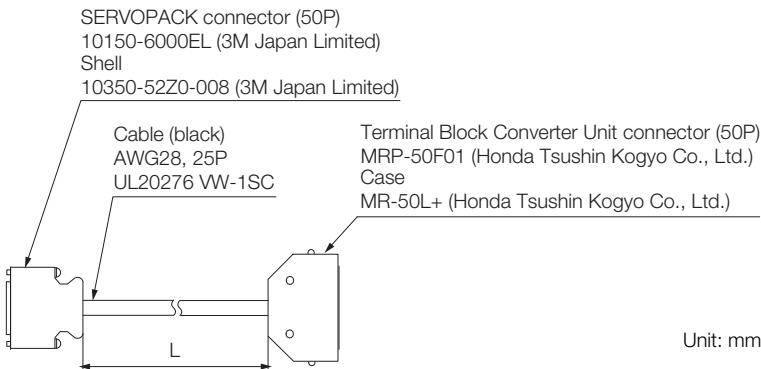

Note: The same pin numbers are used for the SERVOPACK connector and the terminal block. To assemble your own cables, refer to the following section for the wiring specifications.

◆ **Wiring Specifications** on page 10-27

10.6 Safety Function Device Cable

10.6.1 Cables with Connectors

Selection Table

Order Number	Length (L)	Inquires
JZSP-CVH03-01-E	1 m	Yaskawa representative
JZSP-CVH03-03-E	3 m	

Note: When using safety functions, connect this Cable to the safety function devices.
 When not using safety functions, connect the enclosed Safety Jumper Connector to the SERVOPACK.

Dimensional Drawing

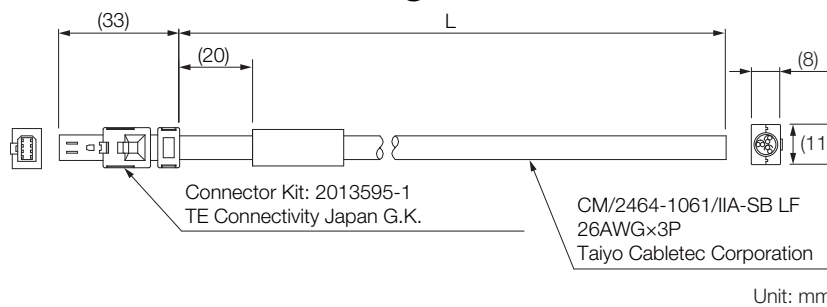

Wiring Specifications

Pin	Signal	Lead Color	Markings
1	Not connected	-	-
2	Not connected	-	-
3	/HWBB1-	White	Black
4	/HWBB1+	White	Red
5	/HWBB2-	Light gray	Black
6	/HWBB2+	Light gray	Red
7	EDM1-	Orange	Black
8	EDM1+	Orange	Red

10.6.2 Connector Kits

Selection Table

Order Number	Product Name	Inquires
2013595-1	INDUSTRIAL MINI I/O D-SHAPE TYPE1 PLUG CONNECTOR KIT	TE Connectivity Japan G.K.

Dimensional Drawing

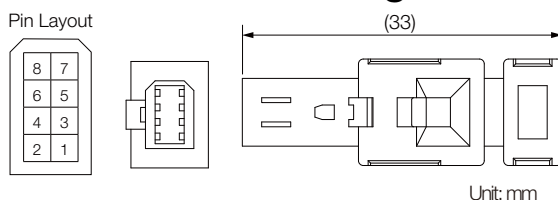

10.7 MECHATROLINK-II Communications Cable



Important Use the Yaskawa-specified cables for the MECHATROLINK Communications Cables. Operation will not be dependable due to low noise resistance with any other cable.

Selection Table

Type	Length (L)	Cable Characteristic	Order Number * ¹	Inquires
Cables with Connectors on Both Ends and No Ferrite Cores	0.5 m, 1 m, 2 m, 3 m, 4 m, 5 m, 6 m, 10 m, 20 m, 30 m, 40 m, and 50 m	Standard Cable	JEPMC-W6002-□□-E (□□: A5/01/03/04/05/06/10/20/30/40/50)	Yaskawa representative
	5 m, 10 m, and 15 m	Flexible Cable * ²	JEPMC-W6005-□□-E (□□: 05/10/15)	
Cables with Connectors on Both Ends and Ferrite Cores	0.5 m, 1 m, 3 m, 5 m, 10 m, 20 m, 30 m, 40 m, and 50 m	Standard Cable	JEPMC-W6003-□□-E (□□: A5/01/03/05/10/20/30/40/50)	
	5 m, 10 m, and 15 m	Flexible Cable * ²	JEPMC-W6006-□□-E (□□: 05/10/15)	
Terminators	–	–	JEPMC-W6022-E	

*1. Replace the boxes (□□) in the order number with the code for the cable length.

*2. The recommended bending radius (R) is 19.2 mm or larger.

External Dimensions

◆ Cable with Connectors on Both Ends

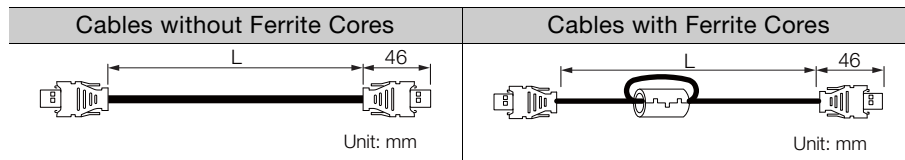

◆ Terminators

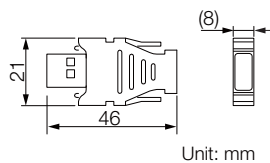

10.8 MECHATROLINK-III Communications Cable



Use the Yaskawa-specified cables for the MECHATROLINK Communications Cables. Operation will not be dependable due to low noise resistance with any other cable.

Important

Selection Table

Type	Length (L)	Order Number*	Inquires
Cables with Connectors on Both Ends and No Ferrite Cores	0.2 m, 0.5 m, 1 m, 2 m, 3 m, 4 m, 5 m, 10 m, 20 m, 30 m, and 50 m	JEPMC-W6012-□□-E (□□: A2/A5/01/02/03/04/05/10/20/30/50)	Yaskawa representative
Cables with Connectors on Both Ends and Ferrite Cores	10 m, 20 m, 30 m, and 50 m	JEPMC-W6013-□□-E (□□: 10/20/30/50)	
Cable with Loose Wires at One End	0.5 m, 1 m, 3 m, 5 m, 10 m, 30 m, and 50 m	JEPMC-W6014-□□-E (□□: A5/01/03/05/10/30/50)	

* Replace the boxes (□□) in the order number with the code for the cable length.

External Dimensions

◆ Cables with Connectors on Both Ends

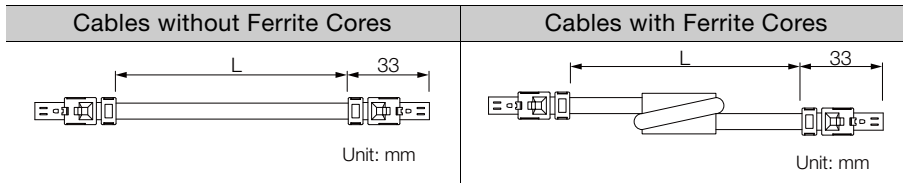

◆ Cable with Loose Wires at One End

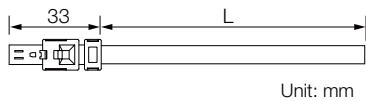

10.9 MECHATROLINK-4 Communications Cable



Use the Yaskawa-specified cables for the MECHATROLINK Communications Cables. Operation will not be dependable due to low noise resistance with any other cable.

Important

Selection Table

Type	Length (L)	Order Number*	Inquiries
Cables with Connectors on Both Ends and No Ferrite Cores	0.2 m, 0.5 m, 1 m, 2 m, 3 m, 4 m, 5 m, 10 m	JZSP-CM3RRM0-□□-E (□□: 00P2/00P5/01/02/03/04/05/10)	Yaskawa representative
	20 m, 30 m	JZSP-CM3RR00-□□-E (□□: 20/30)	
Cables with Connectors on Both Ends and Ferrite Cores	0.3 m, 3 m, 10 m	JZSP-CM3RRM1-□□-E (□□: 00P3/03/10)	
	20 m, 30 m, 50 m	JZSP-CM3RR01-□□-E (□□: 20/30/50)	

* Replace the boxes (□□) in the order number with the code for the cable length.

External Dimensions

◆ Cables with Connectors on Both Ends

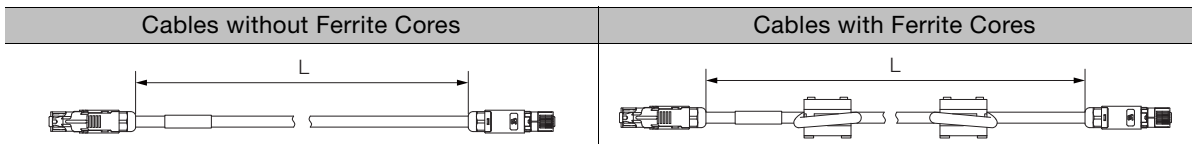

Cables and User-Assembled Wiring Materials for SERVOPACKs

10.10 Cables to Connect to MP3000/MP2000-Series Machine Controllers

10.10.1 Cables to Connect to SVA-01 Analog Output Motion Modules

Selection Table

Order Number	Length (L)	Inquires
JEPMC-W2040-A5	0.5 m	Yaskawa representative
JEPMC-W2040-01	1 m	
JEPMC-W2040-03	3 m	

External Dimensions

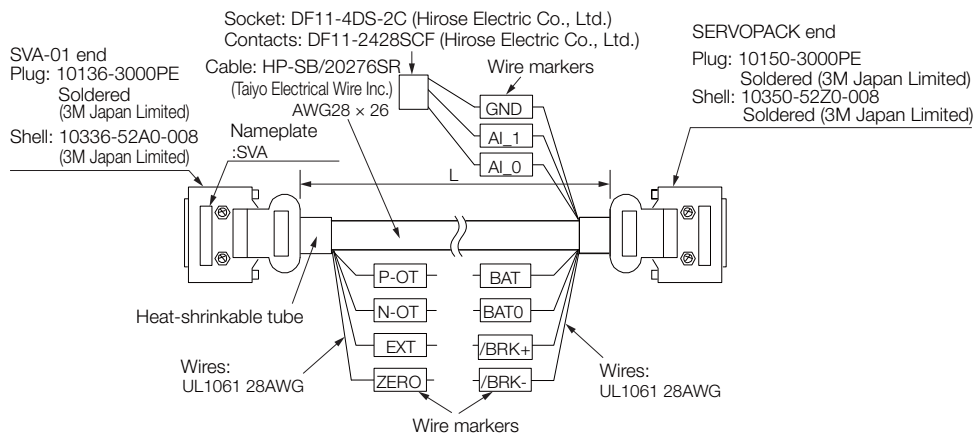

Wiring Specifications

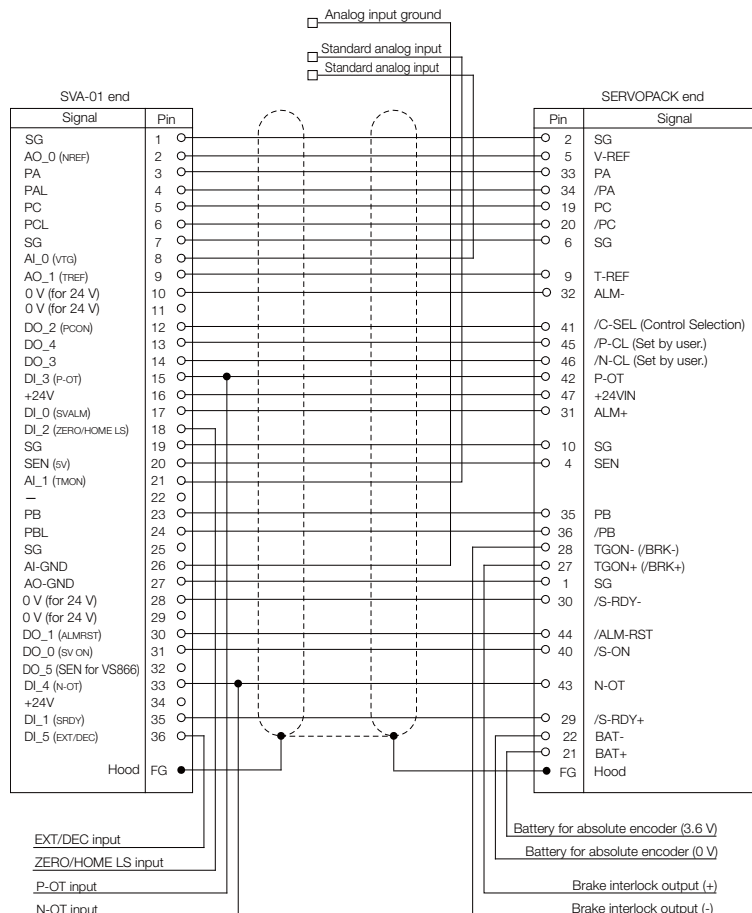

10.11 I/O Signal Cables for INDEXER Modules

Use these Cables to connect INDEXER Modules to host controllers.

10.11.1 Cables with Loose Wires at One End

Selection Table

Order Number	Length (L)	Inquiries
JZSP-CVI01-1-E	1 m	Yaskawa representative
JZSP-CVI01-2-E	2 m	
JZSP-CVI01-3-E	3 m	

Dimensional Drawing

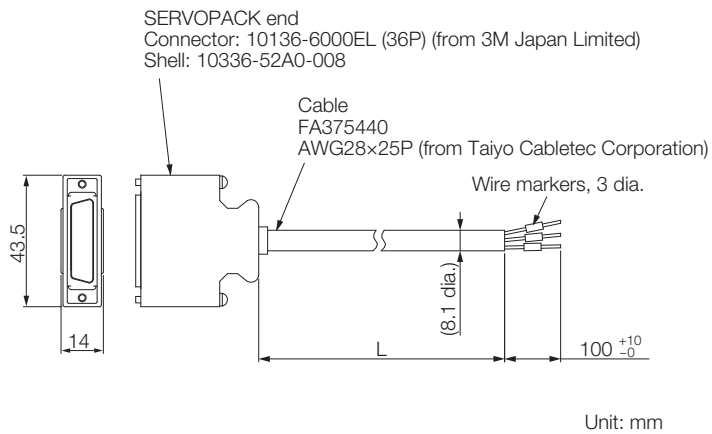

Wiring Specifications

Pin	SERVOPACK end		Wire Color	Markings		Wire Marker No.
	MODE0	MODE1		Color	Qty	
1	+24V/COM		Orange	Red	1	1
2	-		-	-	-	-
3	/MODE 0/1		Gray	Red	1	3
4	-		-	-	-	-
5	/START-STOP	/HOME	White	Red	1	5
6	-		-	-	-	-
7	/PGMPRES	/JOGP	Yellow	Red	1	7
8	-		-	-	-	-
9	/SEL0	/JOGN	Pink	Red	1	9
10	-		-	-	-	-
11	/SEL1	/JOG0	Orange	Red	2	11
12	-		-	-	-	-
13	/SEL2	/JOG1	Gray	Red	2	13
14	/SEL5		White	Red	2	14
15	/SEL3	/JOG2	Yellow	Red	2	15
16	/SEL6		Pink	Red	2	16
17	/SEL4	/JOG3	Orange	Red	3	17
18	/SEL7		Gray	Red	3	18
19	/INPOSITION+		White	Red	3	19
20	/INPOSITION-		White	Black	3	20
21	/POUT0+		Yellow	Red	3	21
22	/POUT0-		Yellow	Black	3	22
23	/POUT1+		Pink	Red	3	23
24	/POUT1-		Pink	Black	3	24
25	/POUT2+		Orange	Red	4	25
26	/POUT2-		Orange	Black	4	26
27	/POUT3+		Gray	Red	4	27
28	/POUT3-		Gray	Black	4	28
29	/POUT4+		White	Red	4	29
30	/POUT4-		White	Black	4	30
31	/POUT5+		Yellow	Red	4	31
32	/POUT5-		Yellow	Black	4	32
33	/POUT6+		Pink	Red	4	33
34	/POUT6-		Pink	Black	4	34
35	/POUT7+		Orange	Red	Continuous dots	35
36	/POUT7-		Orange	Black	Continuous dots	36
Case	Shield		-	-	-	-

⚡: Represents twisted-pair wires.

10.11.2 Connector Kits

Selection Table

Connector Kit Order Number	Case		Connector	
	Model	Qty	Model	Qty
DP9420007-E	10336-52A0-008*	1 set	10136-3000PE* (soldered)	1

* From 3M Japan Limited

- Wire Sizes

Item	Specification
Cable	Use a twisted-pair or screened twisted-pair cable.
Applicable Wires	AWG24, AWG26, AWG28, or AWG30
Cable Finished Diameter	16 mm max.

Dimensional Drawings

◆ Connector

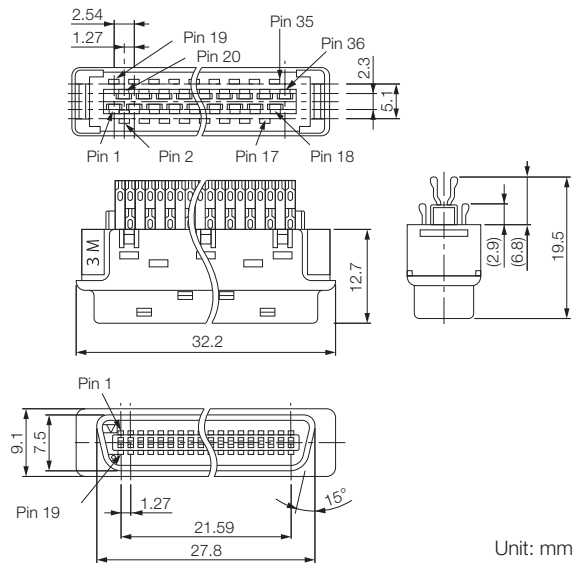

◆ Case

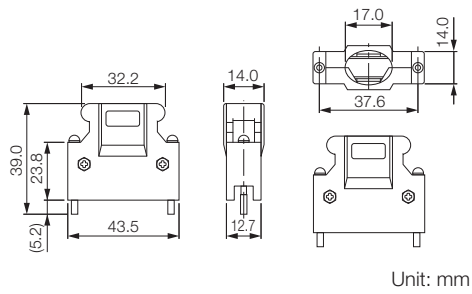

10.11.3 Cables with Terminal Block on One End

Selection Table

Order Number	Length of Enclosed Cable (L)	Approx. Mass	Inquiries
JUSP-TA36V-E	0.5 m	100 g	Yaskawa representative
JUSP-TA36V-1-E	1 m	200 g	
JUSP-TA36V-2-E	2 m	400 g	

Dimensional Drawings

◆ Terminal Block

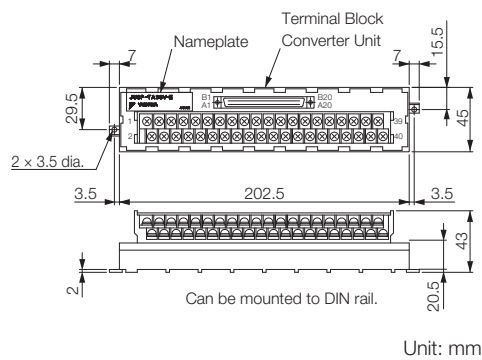

◆ Enclosed Cable

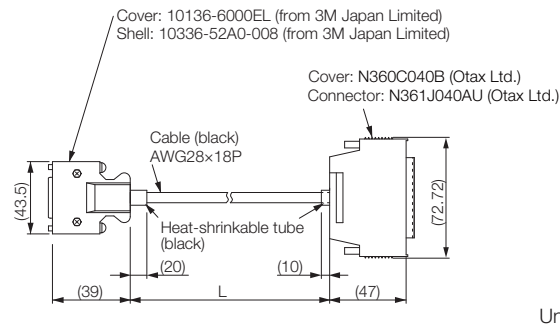

Note: The same pin numbers are used for the SERVOPACK connector and the terminal block. Pins 1 to 36 are wired. Do not connect pins 37 and higher.

To assemble your own cables, refer to the following section for the wiring specifications.

☞ 10.11.1 Cables with Loose Wires at One End on page 10-35

10.12 Serial Command Cables (Connector Kit Only)

Use these Cables to connect INDEXER Modules to host controllers. The Connector Kit that is used is given below. Consult your Yaskawa representative for the cable.

Selection Table

Connector Kit Model Number	Case		Connector	
	Model	Qty	Model	Qty
JZSP-CHI9-1	10314-52A0-008*	1 set	10114-3000PE* (soldered)	1

* From 3M Japan Limited

• Wire Sizes

Item	Specification
Cable	Use a twisted-pair or screened twisted-pair cable.
Applicable Wires	AWG24, AWG26, AWG28, or AWG30
Cable Finished Diameter	16 mm max.

Dimensional Drawings

◆ Connector

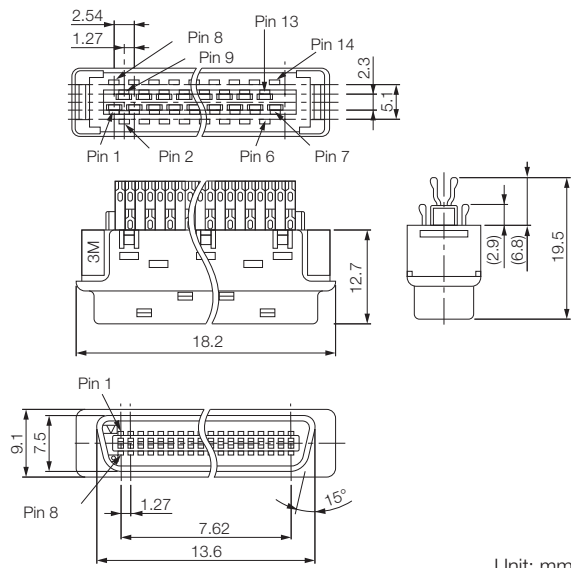

Unit: mm

◆ Case

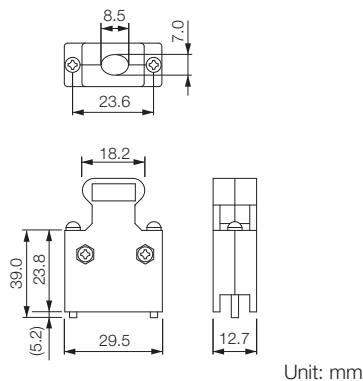

Unit: mm

10.13 DeviceNet Communications Cable

The communications cable must be an ODVA-Compliant DeviceNet communications cable. We recommend the following Cable.

OMRON DCA1-5CN02F1 Cable with Connectors or the equivalent.

Option Modules

11

11.1	Feedback Option Modules	11-2
11.1.1	Fully-Closed Modules	11-2
11.2	Safety Module	11-11
11.2.1	Compliant Standards and Functions	11-11
11.2.2	Specifications	11-12
11.2.3	External Dimensions	11-14
11.3	Option Case Kit	11-15

11.1 Feedback Option Modules

11.1.1 Fully-Closed Modules

You can perform fully-closed loop control by combining a Fully-Closed Module and SERVOPACK.

Fully-closed loop control is used to perform high-accuracy, high-response position control by using a position feedback signal from a Linear Encoder or Absolute Rotary Encoder mounted to the machine. To perform fully-closed loop control, a Fully-Closed Module and SERVOPACK are required.



Important

1. One Option Case Kit is required for each SERVOPACK.
Option Case Kit model: SGDV-OZA01A
2. Refer to the following catalog when using these Command Option Modules with Fully-Closed Module.
 - INDEXER Module
 - DeviceNet Module

 AC Servo Drives Σ -7 Series (Catalog No.: KAEP S800001 23)
3. Fully-Closed Module cannot be used with Safety Modules.

Basic Specifications

Item		Specification	
Operating Conditions	Surrounding Air Temperature	0 to +55°C	
	Storage Temperature	-20°C to +85°C	
	Surrounding Air Humidity	90% relative humidity max.	There must be no freezing or condensation.
	Storage Humidity	90% relative humidity max.	
	Vibration Resistance	4.9 m/s ²	
	Shock Resistance	19.6 m/s ²	
	Degree of Protection	IP10	<ul style="list-style-type: none"> • Must be no corrosive or flammable gases. • Must be no exposure to water, oil, or chemicals. • Must be no dust, salts, or iron dust.
	Pollution Degree	2	
	Altitude	1,000 m max.	
	Others	Do not use the SERVOPACK in the following locations: Locations subject to static electricity noise, strong electromagnetic/magnetic fields, or radioactivity	

Pin Arrangement of External Encoder Connector (CN31)

The following table lists the signal names and functions.

Pin No.	Signal	Function
1	PG5V	Encoder power supply +5 V
2	PG0V	Encoder power supply 0 V
3	–	–
4	–	–
5	PS	Serial data (+)
6	/PS	Serial data (-)
Shell	Shield	–

Recommended Encoders

◆ Linear Encoders

Refer to the following section for the recommended Linear Encoder models and specifications.

☞ 9.1 Recommended Linear Encoders on page 9-3

◆ Rotary Encoders

■ Absolute Rotary Encoders

The following Absolute Rotary Encoders are for fully-closed control. Do not use it to control the motor.

Output Signal	Manufacturer	Rotary Encoder Type	Model			Resolution Bits	Maximum Speed*1 [min ⁻¹]
			Scale	Sensor Head	Relay Device between Fully-Closed Module and Rotary Encoder		
Encoder for Yaskawa's Serial Interface	Magnescape Co., Ltd.	Sealed	RU77-4096ADF*2	—	—	20	2000
			RU77-4096AFFT01*2	—	—	22	2000
	Dr. JOHANNES HEIDENHAIN GmbH	Exposed	ECA4412*2	—	EIB3391Y	27	1600
				—	EIB3391Y	28	800
				—	EIB3391Y	29	400
		Sealed	RCN2310*2	EIB3391Y	26	3000	
			RCN5510*2	EIB3391Y	28	800	
			RCN8310*2	EIB3391Y	29	400	
	ROC2310*2		EIB3391Y	26	3000		
	Renishaw PLC	Exposed	RA23Y-□□□□□□□□□□*2	—	—	23	14600
			RA26Y-□□□□□□□□□□*2	—	—	26	3250
			RA30Y-□□□□□□□□□□*2	—	—	30	200
	Canon Precision Inc.	Exposed	PH03-33L00	—	—	19	2500
			PH03-34L00	—	—	20	
			PH03-35L00	—	—	21	
			PH03-36L00	—	—	22	
			PH03-37L00	—	—	23	

*1. The maximum speeds given in the above table are the maximum applicable speeds of the encoders when combined with a Yaskawa SERVOPACK.

The actual speed will be restricted by either the maximum speed of the Rotary Servomotor or the maximum speed of the Rotary Encoder (given above).

*2. This is a single-turn absolute encoder.

Note: Confirm detailed specifications, such as the tolerances, dimensions, and operating environment, with the manufacturer of the Rotary Encoder before you use it.

Equipment Configurations

◆ Connections to Linear Encoder from Dr. JOHANNES HEIDENHAIN GmbH

■ Connections for a 1 Vp-p Analog Voltage Output Signal

You must make the connections through a Yaskawa Serial Converter Unit. The output signal will be multiplied by 8 bits (256 divisions) in the Serial Converter Unit.

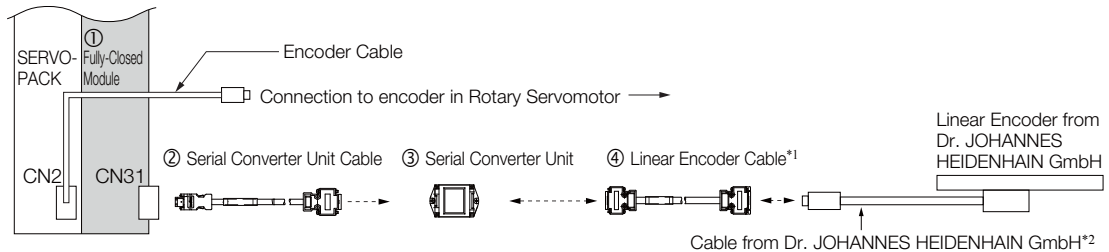

*1. When using a JZDP-J00□-□□□ Serial Converter Unit, do not use a Yaskawa Linear Encoder Cable that is longer than 3 m.

*2. Contact Dr. JOHANNES HEIDENHAIN GmbH for details on cables (analog 1 Vp-p output, D-sub 15-pin, male) from Dr. JOHANNES HEIDENHAIN GmbH.

No.	Item	Model	Reference
①	Fully-Closed Module (Purchased as a set with the SERVOPACK)	Without options: SGD7S□□□□□0A000□□1*1 With options: SGD7S□□□□□0A■■■□□1*1 Note: When a hardware option is mounted, ■■■ is replaced with a three-digit number that specifies the type of option.	-
	Fully-Closed Module (Purchased alone)	Fully-Closed Module*2 SGDV-OFA01A Option Case Kit*3 SGDV-OZA01A	11-10 11-15
②	Serial Converter Unit Cable	JZSP-CLP70-□□-E	9-26
③	Serial Converter Unit	JZDP-H003-000	9-37
④	Linear Encoder Cable	JZSP-CLL30-□□-E	9-26

*1. The model number of a set that includes the SERVOPACK and an Option Module is not hyphenated after "SGD7S."

*2. When ordering a SERVOPACK and a Fully-Closed Module separately, use this Fully-Closed Module model number.

*3. One Option Case Kit is required for each SERVOPACK. The set includes the module cover, PCB mounting plate, and two mounting screws.

Note: 1. Refer to the following section for a table of the recommended Linear Encoders.

📖 9.1 Recommended Linear Encoders on page 9-3

2. Refer to the following section for the specifications of the Serial Converter Unit.

📖 9.4 Serial Converter Unit on page 9-37

3. Refer to the chapter for your Rotary Servomotor for information on Servomotor Main Circuit Cables and Encoder Cables.

4. If you purchase a Fully-Closed Module by itself, refer to the following manual for the method to mount it to the SERVOPACK.

📖 Σ -V Series/ Σ -V Series for Large-Capacity Models/ Σ -7 Series Installation Guide Fully-Closed Module (Document No.: TOBP C720829 03)

■ Connections When Using a Yaskawa Serial Interface for the Output Signals

• LIC4100/LIC2100/LC115/LC415 Linear Encoder with EIB3391Y Interface Unit

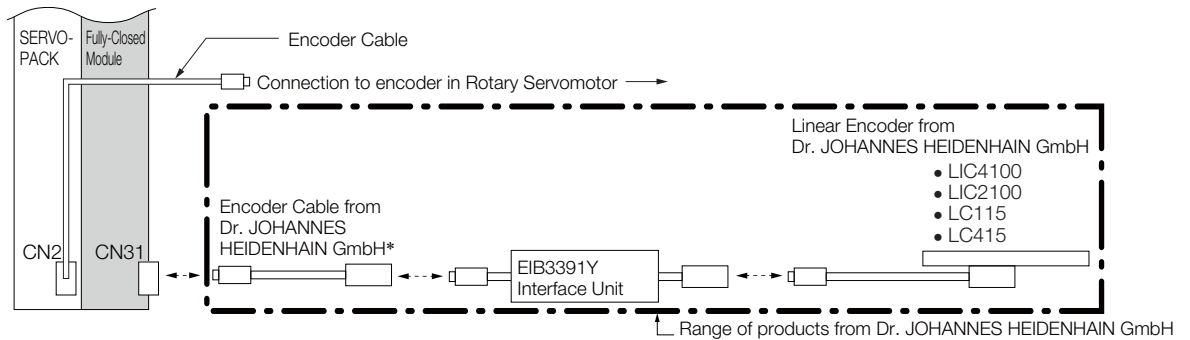

* Use an Encoder Cable from Dr. JOHANNES HEIDENHAIN GmbH. Contact Dr. JOHANNES HEIDENHAIN GmbH for detailed Encoder Cable specifications.

• LIC4190/ LIC2190 Linear Encoder

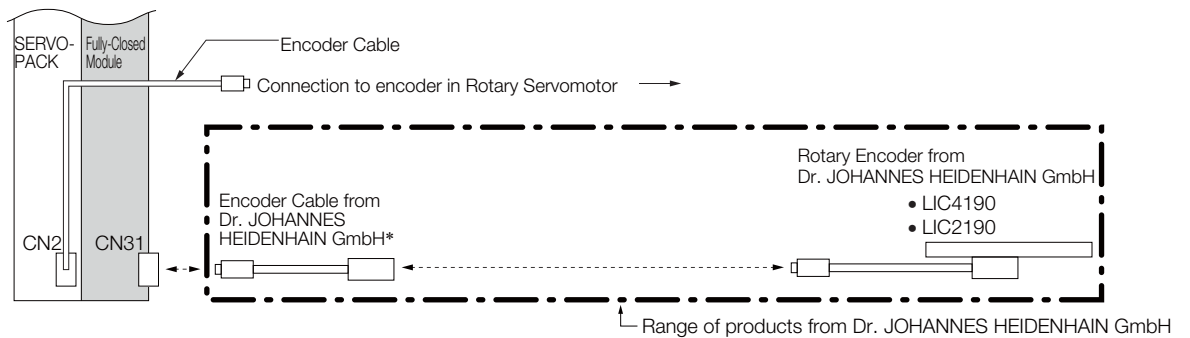

* Use an Encoder Cable from Dr. JOHANNES HEIDENHAIN GmbH. Contact Dr. JOHANNES HEIDENHAIN GmbH for detailed Encoder Cable specifications.

• ECA4412/RCN□□10/ROC□310 Rotary Encoder with EIB3391Y Interface Unit

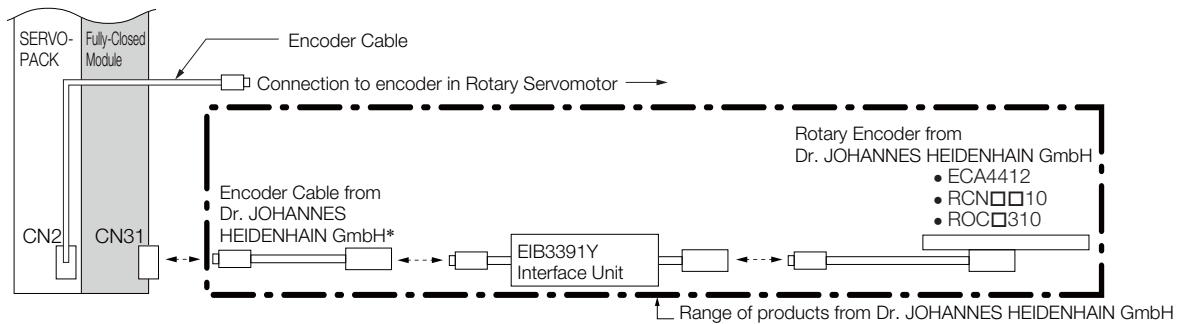

* Use an Encoder Cable from Dr. JOHANNES HEIDENHAIN GmbH. Contact Dr. JOHANNES HEIDENHAIN GmbH for detailed Encoder Cable specifications.

◆ Connections to Linear Encoder from RSF Elektronik GmbH

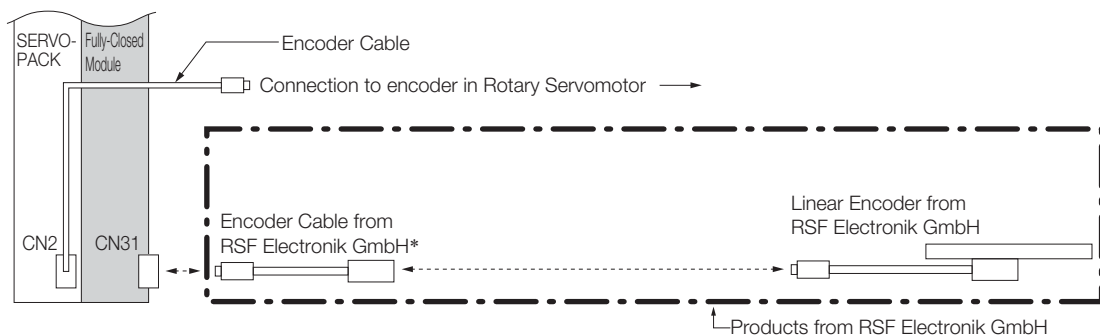

* Use an Encoder Cable from RSF Elektronik GmbH. Contact Dr. JOHANNES HEIDENHAIN GmbH for detailed Encoder Cable specifications.

◆ Connections to Linear Encoder from Renishaw plc

■ Connections for a 1 Vp-p Analog Voltage Output Signal

You must make the connections through a Yaskawa Serial Converter Unit. The output signal will be multiplied by 8 bits (256 divisions) in the Serial Converter Unit.

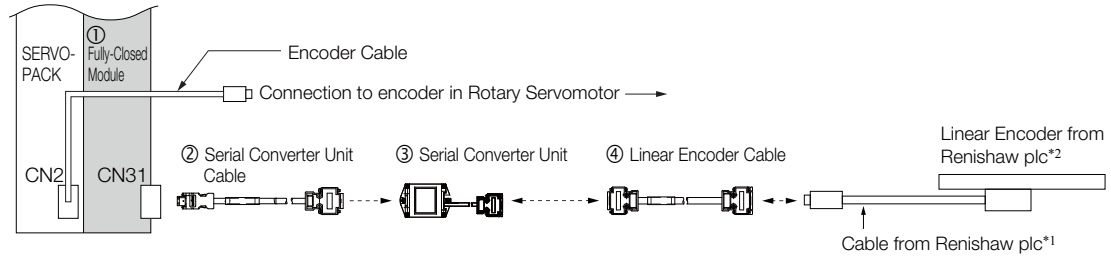

*1. Contact Renishaw plc for details on cables (analog 1 Vp-p output, D-sub 15-pin, male) from Renishaw plc. However, the BID and DIR signals are not connected.

*2. If you use the origin signals with a Linear Encoder from Renishaw plc, the origin may sometimes be falsely detected. If that occurs, use the BID/DIR signal to output the origin signal only in one direction.

No.	Item	Model	Reference
①	Fully-Closed Module (Purchased as a set with the SERVOPACK)	Without options: SGD7S□□□□□□0A000□□1*1 With options: SGD7S□□□□□□0A■■■□□1*1 Note: When a hardware option is mounted, ■■■ is replaced with a three-digit number that specifies the type of option.	-
	Fully-Closed Module (Purchased alone)	Fully-Closed Module*2 SGDV-OFA01A Option Case Kit*3 SGDV-OZA01A	11-10 11-15
②	Serial Converter Unit Cable	JZSP-CLP70-□□-E	9-26
③	Serial Converter Unit	JZDP-H005-000	9-38
④	Linear Encoder Cable	JZSP-CLL00-□□-E	9-26

*1. The model number of a set that includes the SERVOPACK and an Option Module is not hyphenated after “SGD7S.”

*2. When ordering a SERVOPACK and a Fully-Closed Module separately, use this Fully-Closed Module model number.

*3. One Option Case Kit is required for each SERVOPACK.

The set include the module cover, PCB mounting plate, and two mounting screws.

Note: 1. Refer to the following section for a table of the recommended Linear Encoders.

📖 9.1 Recommended Linear Encoders on page 9-3

2. Refer to the following section for the specifications of the Serial Converter Unit.

📖 9.4 Serial Converter Unit on page 9-37

3. Refer to the chapter for your Rotary Servomotor for information on Servomotor Main Circuit Cables and Encoder Cables.

4. If you purchase a Fully-Closed Module by itself, refer to the following manual for the method to mount it to the SERVOPACK.

📖 Σ -V Series/ Σ -V Series for Large-Capacity Models/ Σ -7 Series Installation Guide Fully-Closed Module (Document No.: TOBPC720829 03)

■ Connections When Using a Yaskawa Serial Interface for the Output Signals
 • EVOLUTE-Series/RESOLUTE-Series/FORTiS-Series Linear Encoder

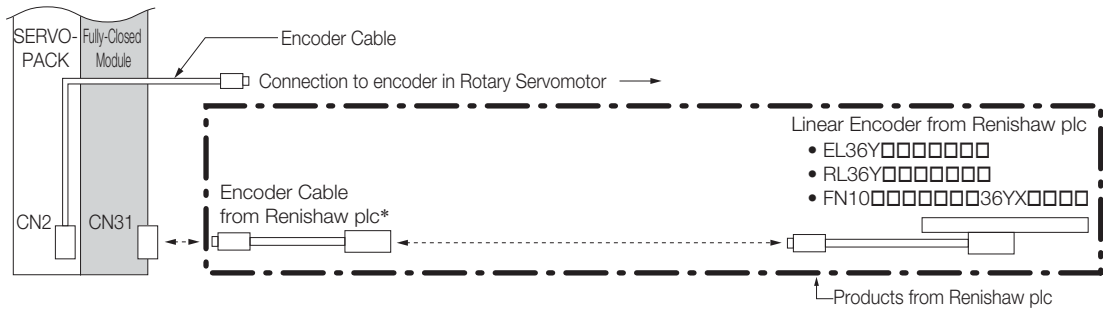

* Use an Encoder Cable from Renishaw plc. Contact Renishaw plc for detailed Encoder Cable specifications.

• RESOLUTE-Series Rotary Encoder

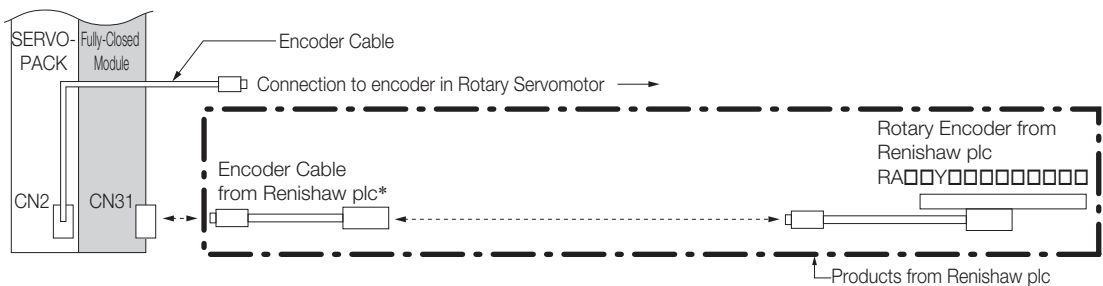

* Use an Encoder Cable from Renishaw plc. Contact Renishaw plc for detailed Encoder Cable specifications.

◆ Connections to Linear Encoder from RLS d.o.o.

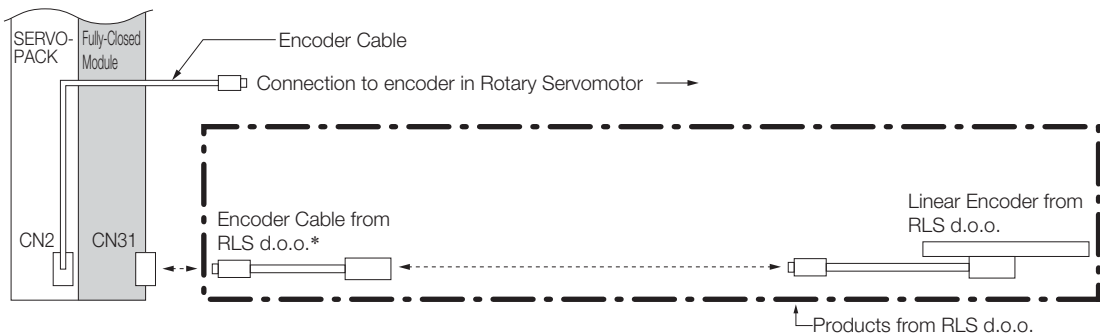

* Use Ean Encoder Cable from RLS d.o.o. For detailed specifications of the Encoder Cables, consult RLS d.o.o. or Renishaw plc.

◆ Connections to Linear Encoder from Magnescale Co., Ltd.

■ SL7□0 Linear Encoder and PL101-RY Sensor Head with Interpolator

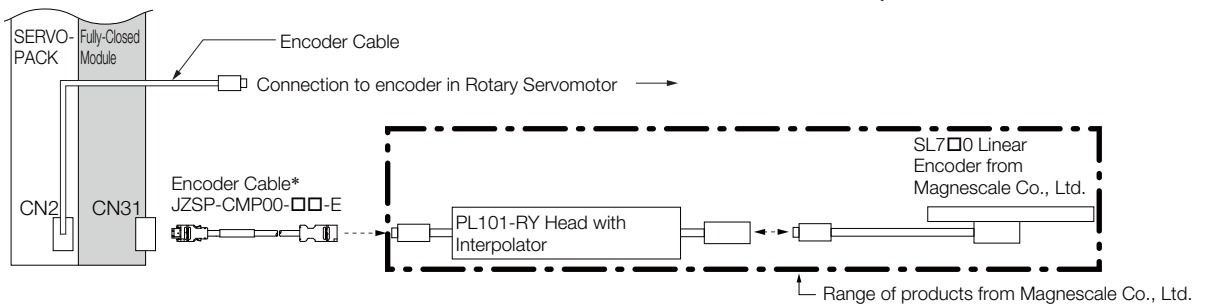

* Refer to the following section for details on Encoder Cables.

📖 9.3.5 Encoder Cables on page 9-27

■ SmartSCALE Linear Encoder (SQ10 Scale +MQ10-FLA Interpolator)

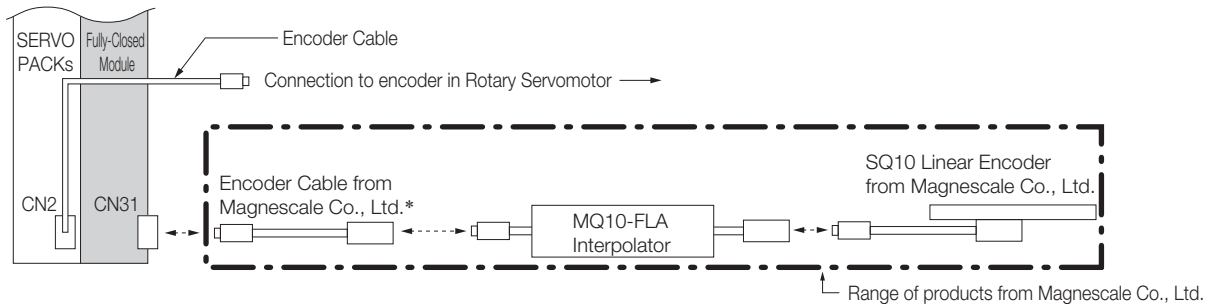

* Use an Encoder Cable from Magnescale Co., Ltd. The maximum length of the Encoder Cable is 15 m. Contact Magnescale Co., Ltd. for specifications other than the cable length.

■ SR-75/SR-77/SR-85/SR-87 Linear Encoders

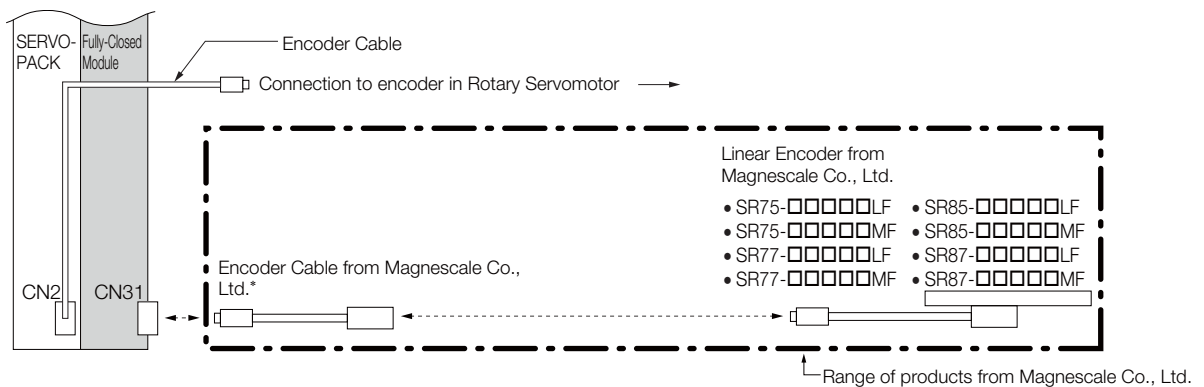

* Use a CH33-xx□□□ Cable from Magnescale Co., Ltd. (This Cable has connectors designed for use with Yaskawa products.)

■ SmartSCALE Linear Encoder (SQ47/SQ57)

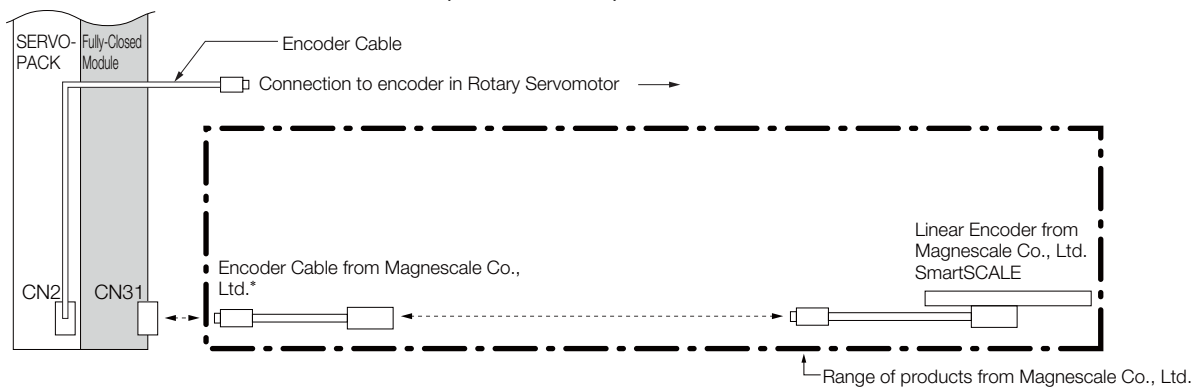

* Use an Encoder Cable from Magnescale Co., Ltd.. Contact Magnescale Co., Ltd. for details on Encoder Cable specifications.

■ RU77-4096ADF/RU77-4096AFFT01 Absolute Rotary Encoders

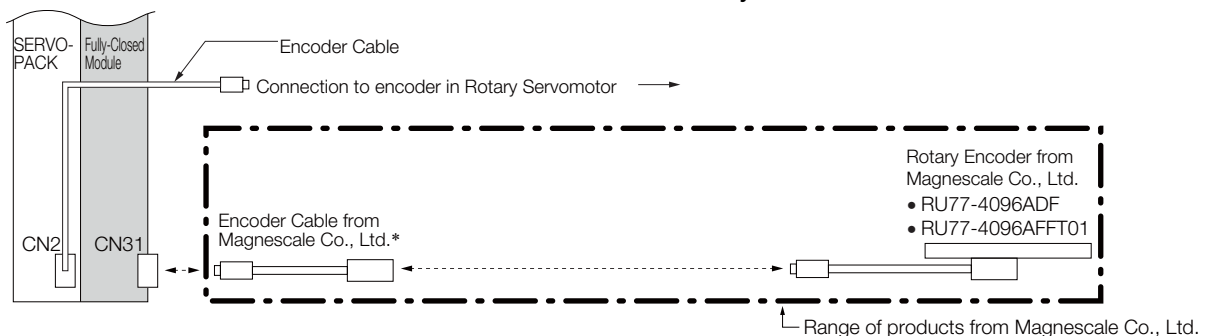

* Use a CE28-Series Extension Cable for RU77 Encoder from Magnescale Co., Ltd.

Note: The RU77 is a single-turn Absolute Rotary Encoder.

◆ Connections to Linear Encoders from Mitutoyo Corporation

■ ST78□□A/ST13□□/AT13□□A Linear Encoder

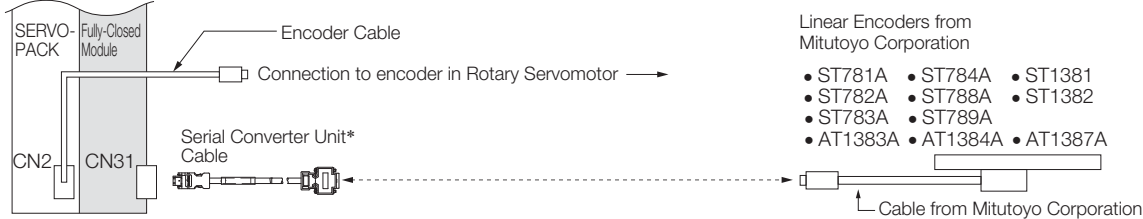

* Refer to the following section for details on Serial Converter Unit Cables.

📄 9.3.3 Serial Converter Unit Cables on page 9-26

◆ Connections to Linear Encoder from Fagor Automation S. Coop.

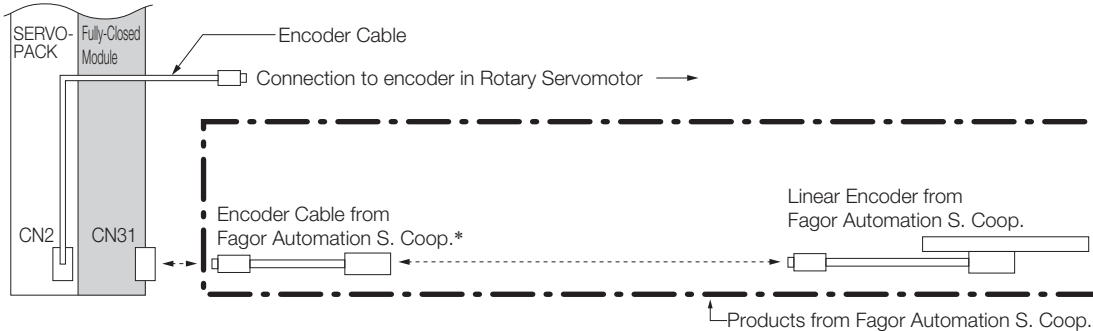

* Use Encoder Cables from Fagor Automation S. Coop. For detailed specifications of the Encoder Cables, consult Fagor Automation S. Coop. or its sales representative.

◆ Connections to Linear Encoder from Canon Precision Inc.

■ PH03-36110/PH03-36120/PH03-36E00 Linear Encoder

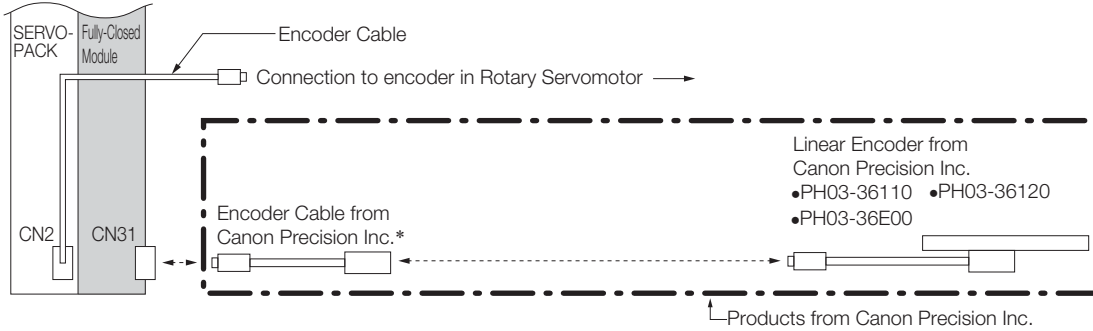

* Use Encoder Cables from Canon Precision Inc. For detailed specifications of the Encoder Cables, consult Canon Precision Inc. or its sales representative.

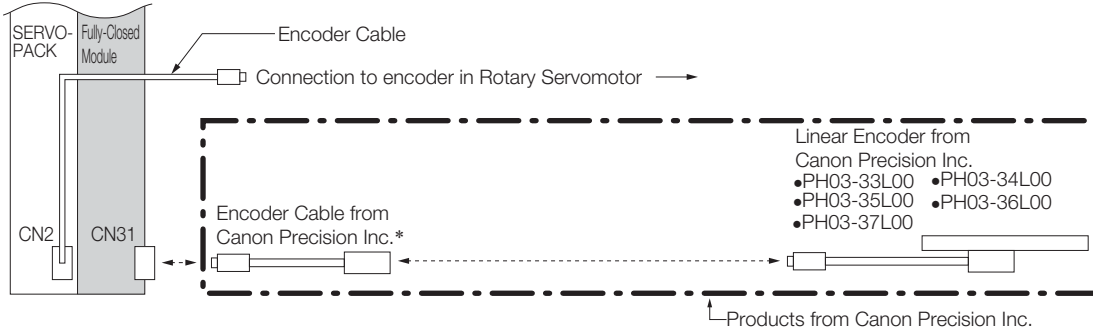

■ PH03-33L00/PH03-34L00/PH03-35L00/PH03-36L00/PH03-37L00 Absolute Rotary Encoder



* Use Encoder Cables from Canon Precision Inc. For detailed specifications of the Encoder Cables, consult Canon Precision Inc. or its sales representative.

Accessories

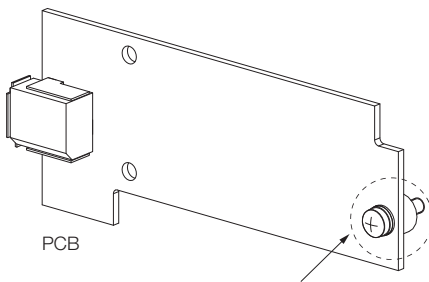
If you purchase a Fully-Closed Module by itself, the following accessories will be packed with it.

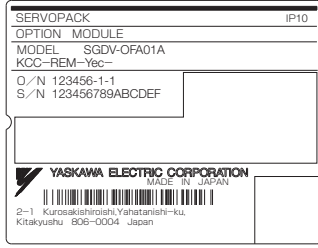
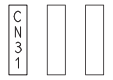
Order Number	SGDV-OFA01A
Accessories	 <p>PCB</p> <p>PCB set screws (two)</p>  <p>Model number nameplate</p>  <p>Ratings nameplate</p>  <p>Device label nameplates</p>

External Dimensions

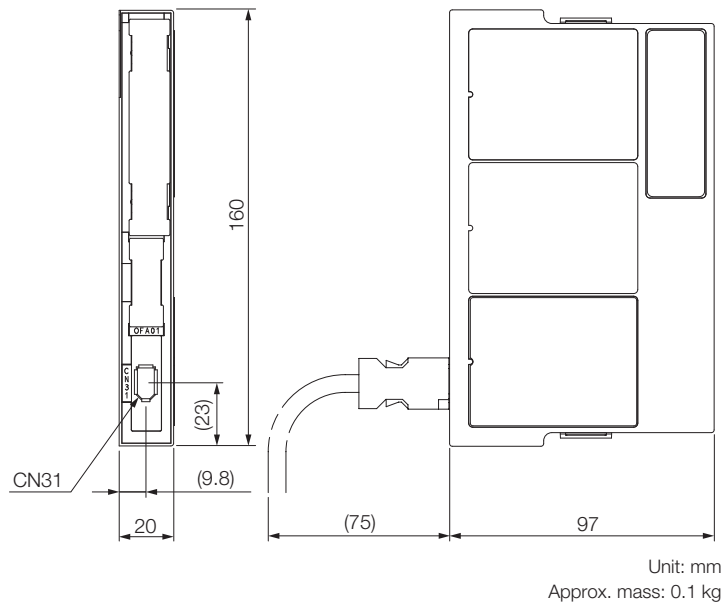

◆ Connectors

Device Label	Model	Number of Pins	Manufacturer
CN31	3E106-0220KV	6	3M Japan Limited

Note: The above connectors or their equivalents are used for the Fully-Closed Module.

11.2 Safety Module

This Safety Module implements safety functions that conform to EN ISO 13849-1 (the harmonized EU Machinery Directive) and are specified in the individual IEC 61800-5-2 standard. You can combine it with an SGD7S SERVOPACK to design optimum safety in a machine system according to industry needs.



Important

1. One Option Case Kit is required for each SERVOPACK.
Option Case Kit model: SGDVOZA01A
2. INDEXER Modules, DeviceNet Modules, and Fully-Closed Modules cannot be used with Safety Modules.
3. The encoders without Yaskawa's serial converter units cannot be connected to SERVOPACKs with a Safety Module.

11.2.1 Compliant Standards and Functions

Compliant Safety Standards

Safety Standard	Compliant Standards	Applicable Products	
		SERVOPACK	SERVOPACK + Safety Module
Safety of Machinery	EN ISO 13849-1:2015 EN 60204-1	✓	✓
Functional Safety	EN 61508 Series EN IEC 62061 EN 61800-5-2	✓	✓
Functional Safety EMC	EN 61326-3-1 EN 61000-6-7	✓	✓

✓: Applicable

Support for Functions Defined in IEC61800-5-2

Safety functions are implemented by using the hard wire base block (HWBB) in the SERVOPACK.

Safety Function	Description	Applicable Products	
		SERVOPACK	SERVOPACK + Safety Module
Safe BaseBlock Function (SBB function)	This safety function is equivalent to an STO function. (It shuts OFF the power supply from the SERVOPACK to the motor.)	✓	✓
Safe BaseBlock with Delay Function (SBB-D function)	This safety function is equivalent to an SS1 function. (It monitors the deceleration operation of the motor for the specified time and then shuts OFF the power supply from the SERVOPACK to the motor.)	–	✓
Safe Position Monitor with Delay Function (SPM-D function)	This safety function is equivalent to an SS2 function. (It monitors the deceleration operation of the motor for the specified time and then monitors the position after the motor stops.)	–	✓

✓: Applicable

Continued on next page.

Continued from previous page.

Safety Function	Description	Applicable Products	
		SERVOPACK	SERVOPACK + Safety Module
Safely Limit Speed with Delay Function (SLS-D function)	This safety function is equivalent to an SLS function. (It monitors the deceleration operation of the motor for the specified time and then monitors the speed of the motor to confirm that it remains in the allowable range.)	-	✓

✓: Applicable

11.2.2 Specifications

Basic Specifications

Item		Specification	
Operating Conditions	Surrounding Air Temperature	0°C to +55°C	
	Storage Temperature	-20°C to +85°C	
	Surrounding Air Humidity	90% relative humidity max.	There must be no freezing or condensation.
	Storage Humidity	90% relative humidity max.	
	Vibration Resistance	4.9 m/s ²	
	Shock Resistance	19.6 m/s ²	
	Degree of Protection	IP10	<ul style="list-style-type: none"> • Must be no corrosive or flammable gases. • Must be no exposure to water, oil, or chemicals. • Must be no dust, salts, or iron dust.
	Pollution Degree	2	
	Altitude	1000 m max.	
	Others	Do not use the SERVOPACK in the following locations: Locations subject to static electricity noise, strong electromagnetic/magnetic fields, or radioactivity	

Compliance with UL Standards, EU Directives, UK Regulations, and Other Safety Standards (in Combination with SERVOPACK)

Item		Specification
North American Safety Standards (UL)		UL61800-5-1 (E147823), CSA C22.2 No.274
EU Directives	Machinery Directive 2006/42/EC	EN ISO 13849-1: 2015 EN IEC 62061 EN 61800-5-2
	EMC Directive 2014/30/EU	EN 55011 Group 1, Class A EN 61000-6-2 EN 61000-6-4 EN 61800-3 (Category C2, Second environment)
	Low Voltage Directive 2014/35/EU	EN 61800-5-1
	RoHS Directive 2011/65/EU (EU)2015/863	EN IEC 63000

Continued on next page.

Continued from previous page.

Item		Specification	
UK Conformity Assessed (UKCA)	Supply of Machinery (Safety) Regulations S.I. 2008/1597	EN ISO 13849-1: 2015 EN IEC 62061 EN 61800-5-2	
	Electromagnetic Compati- bility Regulations S.I. 2016/1091	EN 55011 Group 1, Class A EN 61000-6-2 EN 61000-6-4 EN 61800-3 (Category C2, Second environment)	
	Electrical Equipment (Safety) Regulations S.I. 2016/1101	EN 61800-5-1	
	Restriction of the Use of Certain Hazardous Sub- stances in Electrical and Electronic Equipment Reg- ulations S.I. 2012/3032	EN IEC 63000	
Safety Standards	Safety of Machinery	EN ISO 13849-1: 2015 EN 60204-1	
	Functional Safety	EN 61508 series EN IEC 62061 EN 61800-5-2	
	Functional Safety EMC	EN 61326-3-1 EN 61000-6-7	
Safety Function		EN 61800-5-2	EN 60204-1
		Safe Torque Off (STO)	Stop Category 0
		Safe Stop 1 (SS1)	Stop Category 1
		Safe Stop 2 (SS2)	Stop Category 2
		Safely-Limited Speed (SLS)	
	Number of Blocks	2	
	Safety Function A	Input signals: 2 channels (redundant signals), output signals: 1 channel	
Safety Function B	Input signals: 2 channels (redundant signals), output signals: 1 channel		
Safe Performance			
Safety Integrity Level	SIL2, maximum SIL 2		
Probability of Dangerous Failure per Hour	PFH = 8.0×10^{-9} [1/h] (SBB) PFH = 3.4×10^{-8} [1/h] (SBB-D, SPM-D, SLS-D)		
Category	Cat3		
Performance Level	PLd (Category 2)		
Mean Time to Dangerous Failure of Each Channel	MTTFd: High		
Average Diagnostic Cover- age	DCavg: Medium		
Proof Test Interval	10 years		

11.2.3 External Dimensions

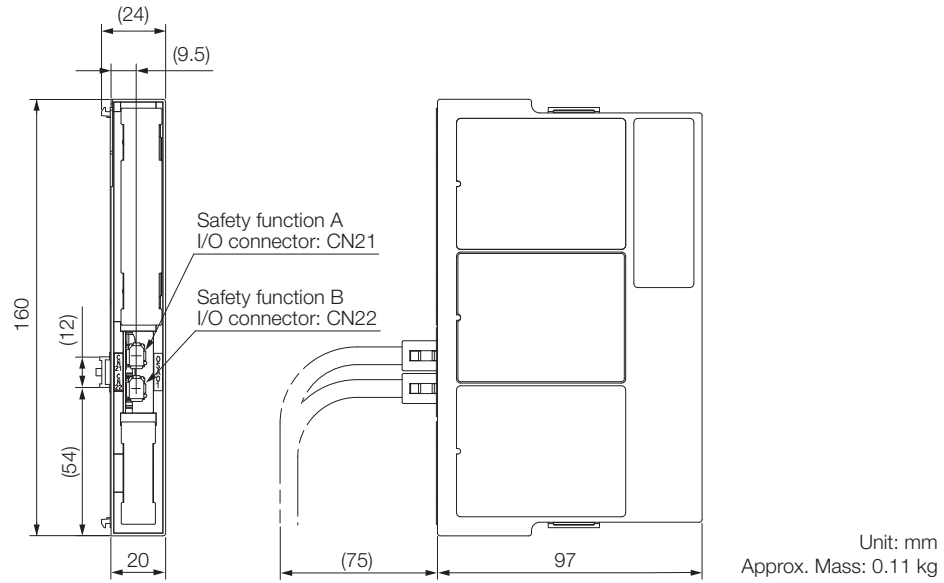

Connectors

Device Label	Model	Number of Pins	Manufacturer
CN21	1981080-1	8	TE Connectivity Japan G.K.
CN22	1981080-1	8	TE Connectivity Japan G.K.

- Note: 1. The above connectors or their equivalents are used for SERVOPACKs.
 2. Refer to the user's manual of the Safety Module for installation standards.

11.3 Option Case Kit

If you purchase the Option Module and SERVOPACK separately, one Option Case Kit is required for each SERVOPACK.

The following accessories are packed with the Option Case Kit.

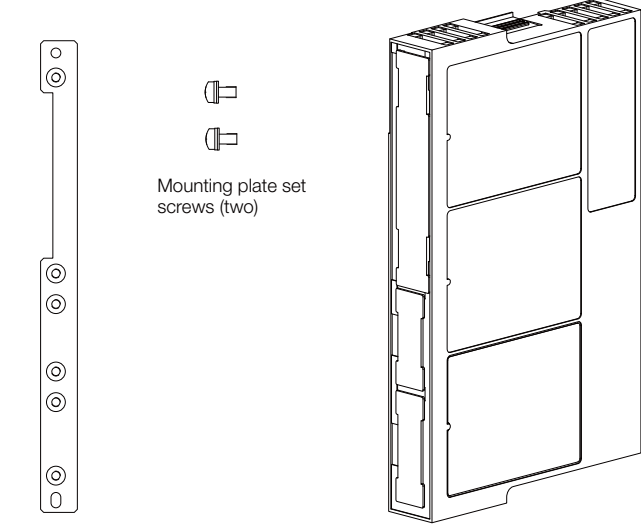
Order Number	SGDV-OZA01A
Accessories	 <p data-bbox="651 1019 817 1048">PCB mounting plate</p> <p data-bbox="805 660 960 698">Mounting plate set screws (two)</p> <p data-bbox="1034 1019 1152 1048">Module cover</p>

SERVOPACK Peripheral Devices

12

12.1 Molded-Case Circuit Breakers and Fuses . . 12-3

- 12.1.1 Using an AC Power Supply 12-3
- 12.1.2 Using a DC Power Supply 12-4

12.2 Magnetic Contactors 12-6

12.3 SERVOPACK Main Circuit Wires 12-10

- 12.3.1 Three-Phase, 200-VAC Wires for Σ -7S
SERVOPACKs 12-10
- 12.3.2 Single-Phase, 200-VAC Wires for Σ -7S
SERVOPACKs 12-13
- 12.3.3 Single-Phase, 100-VAC Wires for Σ -7S
SERVOPACKs 12-14
- 12.3.4 DC Power Supply Wires for Σ -7S
SERVOPACKs 12-15
- 12.3.5 Three-Phase, 200-VAC Wires for Σ -7W
SERVOPACKs and Σ -7C SERVOPACKs 12-18
- 12.3.6 Single-Phase, 200-VAC Wires for Σ -7W
SERVOPACKs and Σ -7C SERVOPACKs 12-19
- 12.3.7 DC Power Supply Wires for Σ -7W
SERVOPACKs 12-19
- 12.3.8 Wire Types 12-20

12.4 Crimp Terminals and Insulating Sleeves . . 12-21

- 12.4.1 Σ -7S SERVOPACKs with Three-Phase,
200-VAC or DC Power Supplies 12-21
- 12.4.2 Σ -7S SERVOPACKs with Single-Phase,
200-VAC 12-22
- 12.4.3 Σ -7S SERVOPACKs with Single-Phase,
100-VAC 12-22
- 12.4.4 Σ -7W SERVOPACKs with Three-Phase, 200-VAC
or DC Power Supplies and Σ -7C SERVOPACKs
with Three-Phase, 200-VAC 12-23
- 12.4.5 Σ -7W SERVOPACKs and Σ -7C SERVO-
PACKs with Single-Phase, 200-VAC 12-23

12.5 Noise Filter 12-25

12.6 AC/DC Reactors 12-28

- 12.6.1 Using a Three-Phase, 200-VAC Power Supply
Input 12-28
- 12.6.2 Using a Single-Phase, 200-VAC Power Supply
Input 12-29
- 12.6.3 Using a Single-Phase, 100-VAC Power Supply
Input 12-29
- 12.6.4 External Dimensions 12-30

12.7 Surge Absorbers 12-31

12.8 Regenerative Resistor 12-32

- 12.8.1 Regenerative Power and Regenerative
Resistance 12-32
- 12.8.2 Types of Regenerative Resistors 12-32
- 12.8.3 Selection Table 12-33
- 12.8.4 Specifications of Built-in Regenerative Resistors
in SERVOPACKs 12-33
- 12.8.5 Specifications and Dimensions of External
Regenerative Resistors 12-34
- 12.8.6 Selecting External Regenerative Resistor 12-37

12.9 Inrush Current Suppression Devices 12-53

12.1 Molded-Case Circuit Breakers and Fuses

12.1.1 Using an AC Power Supply

Use a molded-case circuit breaker and fuse to protect the power supply line. They protect the power line by shutting OFF the circuit when overcurrent is detected. Select these devices based on the information in the following tables.

Note: The following tables provide the net values of the current capacity and inrush current. Select a fuse and a molded-case circuit breaker that meet the following conditions.

- Main circuit and control circuit: No breaking at three times the current value given in the table for 5 s.
- Inrush current: No breaking at the current value given in the table for 20 ms.

Σ-7S SERVOPACKs

Main Circuit Power Supply	Maximum Applicable Motor Capacity [kW]	SERVOPACK Model: SGD7S-	Power Supply Capacity per SERVOPACK [kVA]*	Current Capacity		Inrush Current		Rated Voltage	
				Main Circuit [Arms]*	Control Power Supply [Arms]	Main Circuit [A0-p]	Control Power Supply [A0-p]	Fuse [V]	MCCB [V]
Three-phase, 200 VAC	0.05	R70A	0.2	0.4	0.2	34	34	250	240
	0.1	R90A	0.3	0.8					
	0.2	1R6A	0.5	1.3					
	0.4	2R8A	1.0	2.5					
	0.5	3R8A	1.3	3.0					
	0.75	5R5A	1.6	4.1					
	1.0	7R6A	2.3	5.7					
	1.5	120A	3.2	7.3	0.25				
	2.0	180A	4.0	10					
	3.0	200A	5.9	15					
	5.0	330A	7.5	25	0.3	68			
	6.0	470A	10.7	29					
	7.5	550A	14.6	37					
	11	590A	21.7	54	0.4	114			
15	780A	29.6	73						
Single-phase, 200 VAC	0.05	R70A	0.2	0.8	0.2	34			
	0.1	R90A	0.3	1.6					
	0.2	1R6A	0.6	2.4					
	0.4	2R8A	1.2	5.0					
	0.75	5R5A	1.9	8.7					
	1.5	120A□□□008	4.0	16	0.25				
Single-phase, 100 VAC	0.05	R70F	0.2	1.5	0.38				
	0.1	R90F	0.3	2.5					
	0.2	2R1F	0.6	5					
	0.4	2R8F	1.4	10					

* This is the net value at the rated load.

Σ-7W SERVOPACKs and Σ-7C SERVOPACKs

Main Circuit Power Supply	Maximum Applicable Motor Capacity [kW]	SERVOPACK Model: SGD7W-SGD7C-	Power Supply Capacity per SERVOPACK [kVA] ^{*1}	Current Capacity		Inrush Current		Rated Voltage	
				Main Circuit [Arms] ^{*1}	Control Power Supply [Arms]	Main Circuit [A0-p]	Control Power Supply [A0-p]	Fuse [V]	MCCB [V]
Three-phase, 200 VAC	0.2	1R6A	1.0	2.5	0.25	34	34	250	240
	0.4	2R8A	1.9	4.7					
	0.75	5R5A	3.2	7.8					
	1.0	7R6A	4.5	11					
Single-phase, 200 VAC	0.2	1R6A	1.3	5.5					
	0.4	2R8A	2.4	11					
	0.75	5R5A ^{*2}	2.7	12					

*1. This is the net value at the rated load.

*2. If you use the SGD7W-5R5A or SGD7C-5R5A with a single-phase 200-VAC power supply input, derate the load ratio to 65%. An example is given below.
 If the load ratio of the first axis is 90%, use a load ratio of 40% for the second axis so that average load ratio for both axes is 65%. ((90% + 40%)/2 = 65%)

12.1.2 Using a DC Power Supply

This section gives the power supply specifications for using a DC power supply input. Use the Fuses given in the following tables to protect the power supply line and SERVOPACK. They protect the power line by shutting OFF the circuit when overcurrent is detected.

Note: The following tables provide the net values of the current capacity and inrush current.

Σ-7S SERVOPACKs

Main Circuit Power Supply	SERVOPACK Model: SGD7S-	Power Supply Capacity per SERVOPACK [kVA] ^{*1}	Current Capacity		Inrush Current		External Fuse					
			Main Circuit [Arms] ^{*1}	Control Power Supply [Arms]	Main Circuit [A0-p]	Control Power Supply [A0-p]	Order Number ^{*2}	Current Rating [A]	Voltage Rating [Vdc]			
270 VDC	R70A	0.2	0.5	0.2	34	34	3,5URGJ17/16UL	16	400			
	R90A	0.3	1.0									
	1R6A	0.5	1.5									
	2R8A	1.0	3.0									
	3R8A	1.3	3.8	0.2				3,5URGJ17/20UL		20		
	5R5A	1.6	4.9									
	7R6A	2.3	6.9									
	120A	3.2	11	0.2				34		34	3,5URGJ17/40UL	40
	120A□□□□008			0.25								
	180A											
	200A	5.9	20	0.3				68 ^{*3} (5 Ω external)		34	3,5URGJ17/63UL	63
	330A	7.5	34									
	470A	10.7	36									
	550A	14.6	48									
590A	21.7	68										
780A	29.6	92	0.4	114 ^{*3} (3 Ω external)	34	3,5URGJ23/100UL	100					
						3,5URGJ23/160UL	160					
						3,5URGJ23/200UL	200					

*1. This is the net value at the rated load.

*2. These Fuses are manufactured by MERSEN Japan.

*3. If you use a DC power supply input with any of the following SERVOPACKs, externally connect an inrush current limiting circuit and use the power ON and OFF sequences recommended by Yaskawa: SGD7S-330A, -470A, -550A, -590A, or -780A. There is a risk of equipment damage. For information on the power ON and OFF sequences, refer to the product manual for the type of references used by your SERVOPACK.

Σ-7W SERVOPACKs

Main Circuit Power Supply	SERVOPACK Model: SGD7W-	Power Supply Capacity per SERVOPACK [kVA] ^{*1}	Current Capacity		Inrush Current		External Fuse		
			Main Circuit [Arms] ^{*1}	Control Power Supply [Arms]	Main Circuit [A0-p]	Control Power Supply [A0-p]	Order Number ^{*2}	Current Rating [A]	Voltage Rating [Vdc]
270 VDC	1R6A	1	3.0	0.25	34	34	3,5URGJ17/40UL	40	400
	2R8A	1.9	5.8						
	5R5A	3.2	9.7				3,5URGJ17/63UL	63	
	7R6A	4.5	14						

*1. This is the net value at the rated load.
 *2. These Fuses are manufactured by MERSEN Japan.

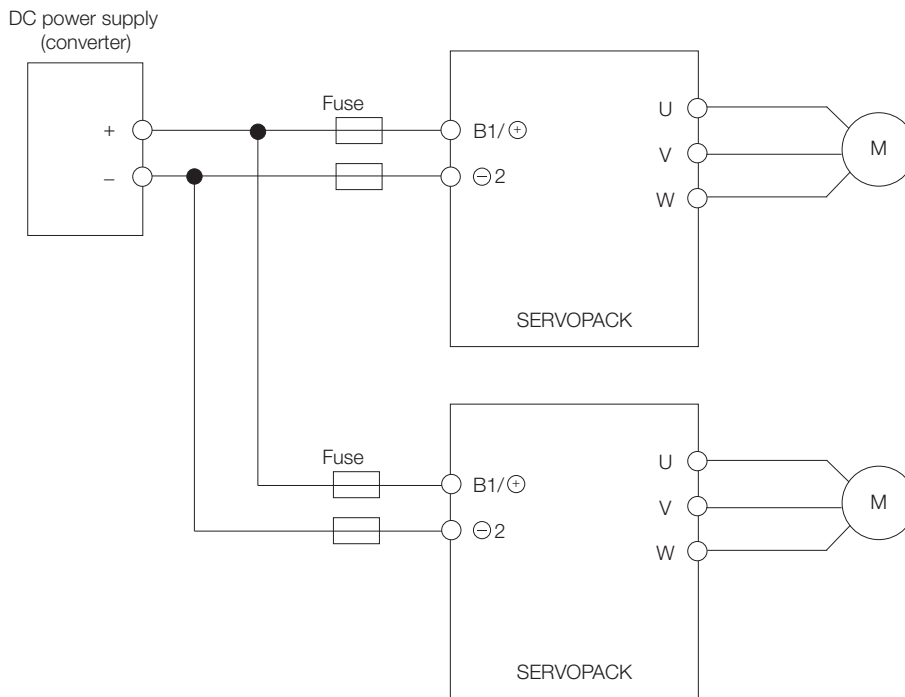

Note: If you connect more than one SERVOPACK to the same DC power supply, connect Fuses for each SERVOPACK.

12.2 Magnetic Contactors

Use a Magnetic Contactor when you configure an external AC power supply sequence.

Note: Always attach a Surge Absorber (e.g., a Surge Absorber unit) to the excitation coil of the magnetic contactor. Consult Fuji Electric FA Components & Systems Co., Ltd. for details.

Selection Table

◆ Σ -7S SERVOPACKs

Main Circuit Power Supply	SERVOPACK		Order Number	Inquiries
	Maximum Applicable Motor Capacity [kW]	Model SGD7S-		
Three-phase, 200 VAC	0.05	R70A	SC-03	Fuji Electric FA Components & Systems Co., Ltd.
	0.1	R90A		
	0.2	1R6A		
	0.4	2R8A		
	0.5	3R8A		
	0.75	5R5A	SC-4-1	
	1.0	7R6A		
	1.5	120A	SC-5-1	
	2.0	180A		
	3.0	200A	SC-N1	
	5.0	330A		
	6.0	470A	SC-N2	
	7.5	550A	SC-N2S	
11	590A	SC-N3		
Single-phase, 200 VAC	0.05	R70A	SC-03	
	0.1	R90A		
	0.2	1R6A		
	0.4	2R8A		
	0.75	5R5A	SC-4-1	
	1.5	120A□□□008	SC-5-1	
Single-phase, 100 VAC	0.05	R70F	SC-03	
	0.1	R90F		
	0.2	2R1F	SC-4-1	
	0.4	2R8F		

◆ Σ -7W SERVOPACKs and Σ -7C SERVOPACKs

Main Circuit Power Supply	SERVOPACK		Order Number	Inquiries
	Maximum Applicable Motor Capacity [kW]	Model SGD7W-SGD7C-		
Three-phase, 200 VAC	0.2	1R6A	SC-03	Fuji Electric FA Components & Systems Co., Ltd.
	0.75	2R8A	SC-4-1	
	0.75	5R5A		
	1.0	7R6A	SC-5-1	
Single-phase, 200 VAC	0.2	1R6A	SC-03	
	0.4	2R8A	SC-4-1	
	0.75	5R5A	SC-5-1	

External Dimensions

◆ Model: SC-03

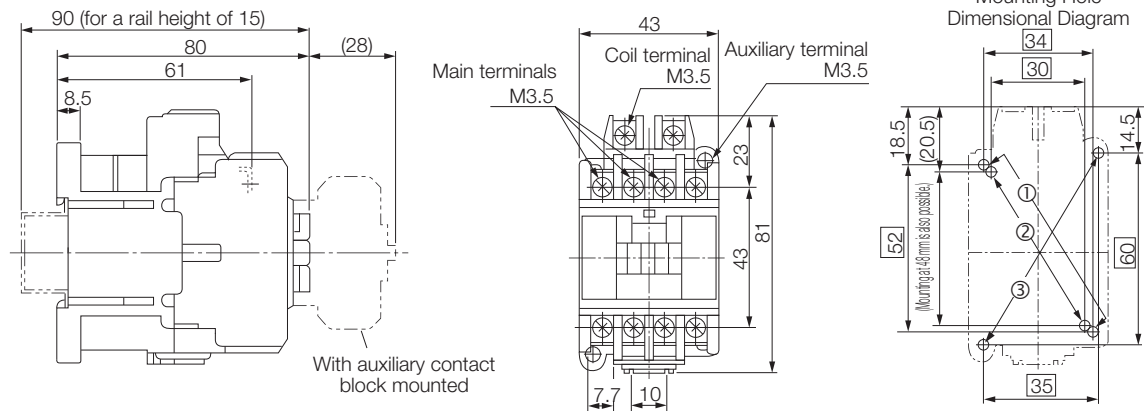

Auxiliary Contacts	Contact Structure
1NO	
1NC	

- You can use any of the following three mounting methods.
 - ①: 34 × (48 to) 52
 - ②: 30 × 48
 - ③: 35 × 60
- Mounting screws: 2 × M4
Use two mounting holes in diagonally opposing corners to mount the Magnetic Contactor.

Unit: mm
Approx. mass: 0.32 kg

◆ Model: SC-4-1

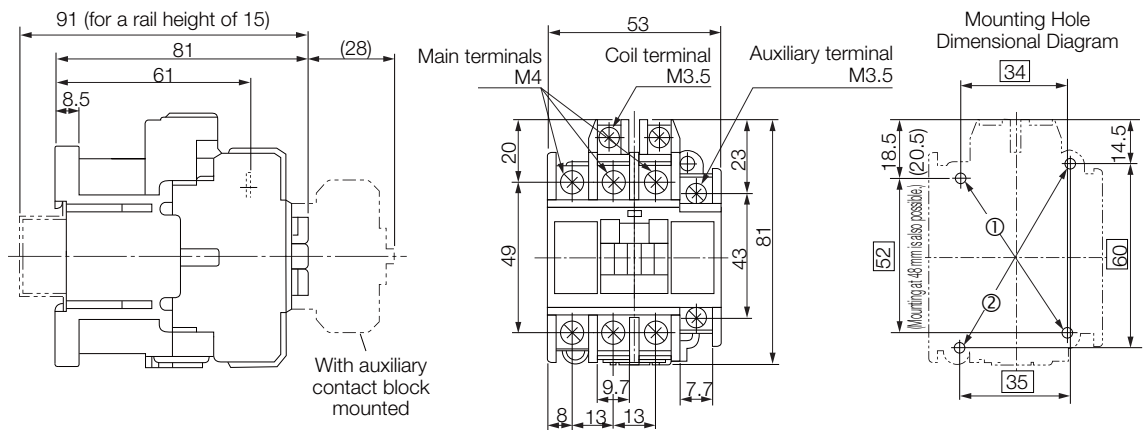

Auxiliary Contacts	Contact Structure
1NO	
1NC	

- You can use either of the following two mounting methods.
 - ①: 34 × (48 to) 52
 - ②: 35 × 60
- Mounting screws: 2 × M4
Use two mounting holes in diagonally opposing corners to mount the Magnetic Contactor.

Unit: mm
Approx. mass: 0.36 kg

◆ Model: SC-5-1

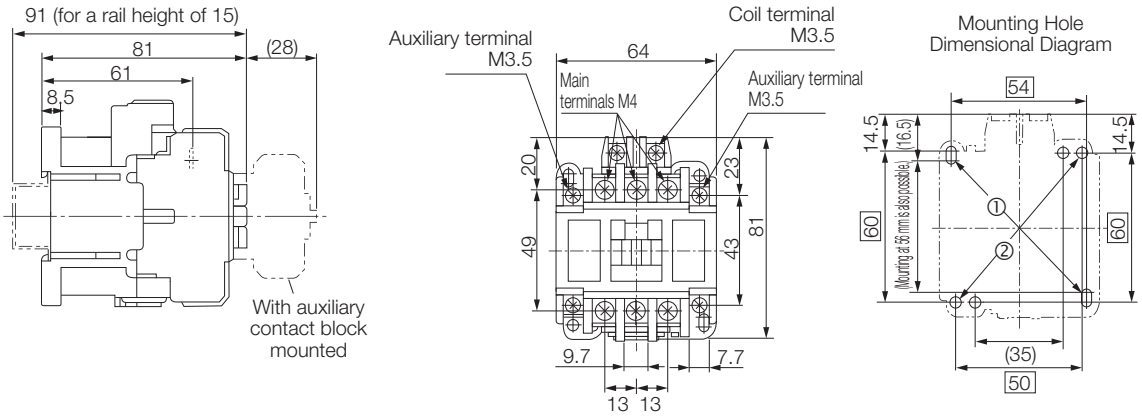

Auxiliary Contacts	Contact Structure
2NO	
1NO/1NC	
2NC	

- You can use either of the following two mounting methods.
 ①: 54 × (56 to) 60
 ②: 50 × 60
- Mounting screws: 2 × M4
 Use two mounting holes in diagonally opposing corners to mount the Magnetic Contactor.

Unit: mm
 Approx. mass: 0.38 kg

◆ Model: SC-N1 or SC-N2

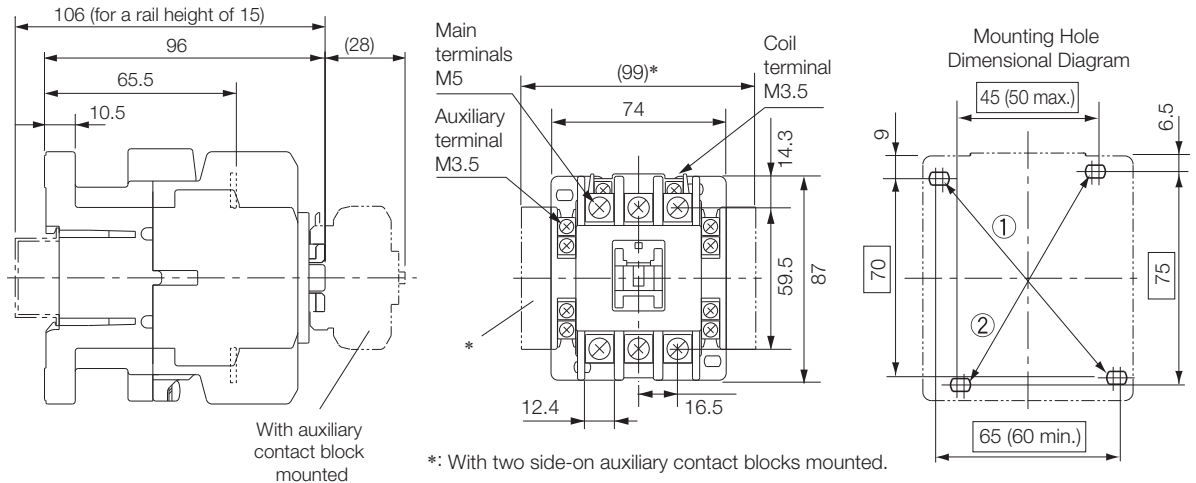

Auxiliary Contacts	Contact Structure
4NO	
2NO/2NC	
4NC	

- You can use either of the following two mounting methods.
 ①: 70 × 75
 ②: (55 to) 65 × 90
- Mounting screws: 2 × M4
 Use two mounting holes in diagonally opposing corners to mount the Magnetic Contactor.

Unit: mm
 Approx. mass: 0.59 kg

◆ Model: SC-N2S or SC-N3

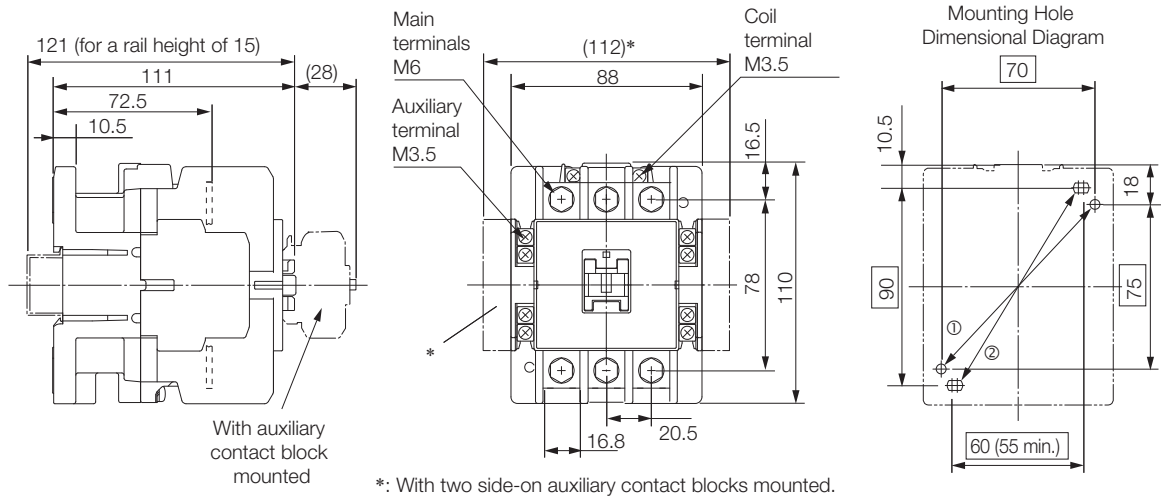

Auxiliary Contacts	Contact Structure
4NO	
2NO/2NC	
4NC	

- You can use either of the following two mounting methods.
 - ①: 70 × 75
 - ②: (55 to) 60 × 90
- Mounting screws: 2 × M4
- Use two mounting holes in diagonally opposing corners to mount the Magnetic Contactor.

Unit: mm
Approx. mass: 1.1 kg

12.3 SERVOPACK Main Circuit Wires

This section describes the main circuit wires for SERVOPACKs.



Important

These specifications are based on IEC/EN 61800-5-1, UL 61800-5-1, and CSA C22.2 No.274.

1. To comply with UL standards, use UL-compliant wires.
2. Use copper wires with a rated temperature of 75° or higher.
3. Use wires with a rated withstand voltage of 300 V or higher.

Note: To use 600-V heat-resistant polyvinyl chloride-insulated wire (HIV), use the following table as reference for the applicable wires.

- The specified wire sizes are for three bundled leads when the rated current is applied with a surrounding air temperature of 40°C.
- Select the wires according to the surrounding air temperature.

12.3.1 Three-Phase, 200-VAC Wires for Σ-7S SERVOPACKs

SERVOPACK Model: SGD7S-	Terminal Symbols		Wire Size	Screw Size	Tightening Torque [N·m]
R70A	Main Circuit Power Supply Cables	L1, L2, L3	AWG16 (1.25 mm ²)	-	-
	Servomotor Main Circuit Cables*	U, V, W			
	Control Power Supply Cables	L1C, L2C			
	External Regenerative Resistor Cables	B1/⊕, B2			
	Ground cable	⊕	AWG14 (2.0 mm ²) or larger	M4	1.2 to 1.4
R90A	Main Circuit Power Supply Cables	L1, L2, L3	AWG16 (1.25 mm ²)	-	-
	Servomotor Main Circuit Cables*	U, V, W			
	Control Power Supply Cables	L1C, L2C			
	External Regenerative Resistor Cables	B1/⊕, B2			
	Ground cable	⊕	AWG14 (2.0 mm ²) or larger	M4	1.2 to 1.4
1R6A	Main Circuit Power Supply Cables	L1, L2, L3	AWG16 (1.25 mm ²)	-	-
	Servomotor Main Circuit Cables*	U, V, W			
	Control Power Supply Cables	L1C, L2C			
	External Regenerative Resistor Cables	B1/⊕, B2			
	Ground cable	⊕	AWG14 (2.0 mm ²) or larger	M4	1.2 to 1.4
2R8A	Main Circuit Power Supply Cables	L1, L2, L3	AWG16 (1.25 mm ²)	-	-
	Servomotor Main Circuit Cables*	U, V, W			
	Control Power Supply Cables	L1C, L2C			
	External Regenerative Resistor Cables	B1/⊕, B2			
	Ground cable	⊕	AWG14 (2.0 mm ²) or larger	M4	1.2 to 1.4

Continued on next page.

Continued from previous page.

SERVOPACK Model: SGD7S-	Terminal Symbols		Wire Size	Screw Size	Tightening Torque [N·m]
3R8A	Main Circuit Power Supply Cables	L1, L2, L3	AWG16 (1.25 mm ²)	-	-
	Servomotor Main Circuit Cables*	U, V, W			
	Control Power Supply Cables	L1C, L2C			
	External Regenerative Resistor Cables	B1/⊕, B2			
	Ground cable	⊕	AWG14 (2.0 mm ²) or larger	M4	1.2 to 1.4
5R5A	Main Circuit Power Supply Cables	L1, L2, L3	AWG16 (1.25 mm ²)	-	-
	Servomotor Main Circuit Cables*	U, V, W			
	Control Power Supply Cables	L1C, L2C			
	External Regenerative Resistor Cables	B1/⊕, B2			
	Ground cable	⊕	AWG14 (2.0 mm ²) or larger	M4	1.2 to 1.4
7R6A	Main Circuit Power Supply Cables	L1, L2, L3	AWG16 (1.25 mm ²)	-	-
	Servomotor Main Circuit Cables*	U, V, W			
	Control Power Supply Cables	L1C, L2C			
	External Regenerative Resistor Cables	B1/⊕, B2			
	Ground cable	⊕	AWG14 (2.0 mm ²) or larger	M4	1.2 to 1.4
120A	Main Circuit Power Supply Cables	L1, L2, L3	AWG14 (2.0 mm ²)	-	-
	Servomotor Main Circuit Cables*	U, V, W			
	Control Power Supply Cables	L1C, L2C	AWG16 (1.25 mm ²)	-	-
	External Regenerative Resistor Cables	B1/⊕, B2			
	Ground cable	⊕	AWG14 (2.0 mm ²) or larger	M4	1.2 to 1.4
180A	Main Circuit Power Supply Cables	L1, L2, L3	AWG14 (2.0 mm ²)	M4	1.0 to 1.2
	Servomotor Main Circuit Cables*	U, V, W	AWG10 (5.5 mm ²)		
	Control Power Supply Cables	L1C, L2C	AWG16 (1.25 mm ²)	M4	1.0 to 1.2
	External Regenerative Resistor Cables	B1/⊕, B2			
	Ground cable	⊕	AWG14 (2.0 mm ²) or larger	M4	1.2 to 1.4
200A	Main Circuit Power Supply Cables	L1, L2, L3	AWG12 (3.5 mm ²)	M4	1.0 to 1.2
	Servomotor Main Circuit Cables*	U, V, W	AWG10 (5.5 mm ²)		
	Control Power Supply Cables	L1C, L2C	AWG16 (1.25 mm ²)	M4	1.0 to 1.2
	External Regenerative Resistor Cables	B1/⊕, B2			
	Ground cable	⊕	AWG14 (2.0 mm ²) or larger	M4	1.2 to 1.4

Continued on next page.

12.3 SERVOPACK Main Circuit Wires

12.3.1 Three-Phase, 200-VAC Wires for Σ -7S SERVOPACKS

Continued from previous page.

SERVOPACK Model: SGD7S-	Terminal Symbols		Wire Size	Screw Size	Tightening Torque [N·m]
330A	Main Circuit Power Supply Cables	L1, L2, L3	AWG8 (8.0 mm ²)	M4	1.0 to 1.2
	Servomotor Main Circuit Cables*	U, V, W			
	Control Power Supply Cables	L1C, L2C	AWG16 (1.25 mm ²)		
	External Regenerative Resistor Cables	B1/⊕, B2	AWG14 (2.0 mm ²)		
	Ground cable	⊕	AWG14 (2.0 mm ²) or larger		
470A	Main Circuit Power Supply Cables	L1, L2, L3	AWG8 (8.0 mm ²)	M5	2.2 to 2.4
	Servomotor Main Circuit Cables*	U, V, W	AWG6 (14 mm ²)		
	Control Power Supply Cables	L1C, L2C	AWG16 (1.25 mm ²)		
	External Regenerative Resistor Cables	B1/⊕, B2	AWG14 (2.0 mm ²)		
	Ground cable	⊕	AWG14 (2.0 mm ²) or larger		
550A	Main Circuit Power Supply Cables	L1, L2, L3	AWG8 (8.0 mm ²)	M5	2.2 to 2.4
	Servomotor Main Circuit Cables*	U, V, W	AWG4 (22 mm ²)		
	Control Power Supply Cables	L1C, L2C	AWG16 (1.25 mm ²)		
	External Regenerative Resistor Cables	B1/⊕, B2	AWG10 (5.5 mm ²)		
	Ground cable	⊕	AWG14 (2.0 mm ²) or larger		
590A	Main Circuit Power Supply Cables	L1, L2, L3	AWG4 (22 mm ²)	M6	2.7 to 3.0
	Servomotor Main Circuit Cables*	U, V, W			
	Control Power Supply Cables	L1C, L2C	AWG16 (1.25 mm ²)		
	External Regenerative Resistor Cables	B1/⊕, B2	AWG10 (5.5 mm ²)		
	Ground cable	⊕	AWG14 (2.0 mm ²) or larger		
780A	Main Circuit Power Supply Cables	L1, L2, L3	AWG3 (30 mm ²)	M6	2.7 to 3.0
	Servomotor Main Circuit Cables*	U, V, W			
	Control Power Supply Cables	L1C, L2C	AWG16 (1.25 mm ²)		
	External Regenerative Resistor Cables	B1/⊕, B2	AWG8 (8.0 mm ²)		
	Ground cable	⊕	AWG14 (2.0 mm ²) or larger		

* If you do not use the recommended Servomotor Main Circuit Cable, use this table to select wires.

12.3.2 Single-Phase, 200-VAC Wires for Σ -7S SERVOPACKs

SERVOPACK Model: SGD7S-	Terminal Symbols		Wire Size	Screw Size	Tightening Torque [N·m]
R70A	Main Circuit Power Supply Cables	L1, L2	AWG16 (1.25 mm ²)	-	-
	Servomotor Main Circuit Cables*	U, V, W			
	Control Power Supply Cables	L1C, L2C			
	External Regenerative Resistor Cables	B1/⊕, B2			
	Ground cable	⊕	AWG14 (2.0 mm ²) or larger	M4	1.2 to 1.4
R90A	Main Circuit Power Supply Cables	L1, L2	AWG16 (1.25 mm ²)	-	-
	Servomotor Main Circuit Cables*	U, V, W			
	Control Power Supply Cables	L1C, L2C			
	External Regenerative Resistor Cables	B1/⊕, B2			
	Ground cable	⊕	AWG14 (2.0 mm ²) or larger	M4	1.2 to 1.4
1R6A	Main Circuit Power Supply Cables	L1, L2, L3	AWG16 (1.25 mm ²)	-	-
	Servomotor Main Circuit Cables*	U, V, W			
	Control Power Supply Cables	L1C, L2C			
	External Regenerative Resistor Cables	B1/⊕, B2			
	Ground cable	⊕	AWG14 (2.0 mm ²) or larger	M4	1.2 to 1.4
2R8A	Main Circuit Power Supply Cables	L1, L2, L3	AWG16 (1.25 mm ²)	-	-
	Servomotor Main Circuit Cables*	U, V, W			
	Control Power Supply Cables	L1C, L2C			
	External Regenerative Resistor Cables	B1/⊕, B2			
	Ground cable	⊕	AWG14 (2.0 mm ²) or larger	M4	1.2 to 1.4
5R5A	Main Circuit Power Supply Cables	L1, L2, L3	AWG14 (2.0 mm ²)	-	-
	Servomotor Main Circuit Cables*	U, V, W	AWG16 (1.25 mm ²)		
	Control Power Supply Cables	L1C, L2C			
	External Regenerative Resistor Cables	B1/⊕, B2			
	Ground cable	⊕	AWG14 (2.0 mm ²) or larger	M4	1.2 to 1.4

Continued on next page.

12.3 SERVOPACK Main Circuit Wires

12.3.3 Single-Phase, 100-VAC Wires for Σ -7S SERVOPACKs

Continued from previous page.

SERVOPACK Model: SGD7S-	Terminal Symbols		Wire Size	Screw Size	Tightening Torque [N·m]
120A□□□008	Main Circuit Power Supply Cables	L1, L2	AWG14 (2.0 mm ²)	M4	1.0 to 1.2
	Servomotor Main Circuit Cables*	U, V, W			
	Control Power Supply Cables	L1C, L2C	AWG16 (1.25 mm ²)		
	External Regenerative Resistor Cables	B1/⊕, B2			
	Ground cable	⊕	AWG14 (2.0 mm ²) or larger		1.2 to 1.4

* If you do not use the recommended Servomotor Main Circuit Cable, use this table to select wires.

12.3.3 Single-Phase, 100-VAC Wires for Σ -7S SERVOPACKs

SERVOPACK Model: SGD7S-	Terminal Symbols		Wire Size	Screw Size	Tightening Torque [N·m]
R70F	Main Circuit Power Supply Cables	L1, L2	AWG16 (1.25 mm ²)	-	-
	Servomotor Main Circuit Cables*	U, V, W			
	Control Power Supply Cables	L1C, L2C			
	External Regenerative Resistor Cables	B1/⊕, B2			
	Ground cable	⊕	AWG14 (2.0 mm ²) or larger	M4	1.2 to 1.4
R90F	Main Circuit Power Supply Cables	L1, L2	AWG16 (1.25 mm ²)	-	-
	Servomotor Main Circuit Cables*	U, V, W			
	Control Power Supply Cables	L1C, L2C			
	External Regenerative Resistor Cables	B1/⊕, B2			
	Ground cable	⊕	AWG14 (2.0 mm ²) or larger	M4	1.2 to 1.4
2R1F	Main Circuit Power Supply Cables	L1, L2	AWG16 (1.25 mm ²)	-	-
	Servomotor Main Circuit Cables*	U, V, W			
	Control Power Supply Cables	L1C, L2C			
	External Regenerative Resistor Cables	B1/⊕, B2			
	Ground cable	⊕	AWG14 (2.0 mm ²) or larger	M4	1.2 to 1.4
2R8F	Main Circuit Power Supply Cables	L1, L2	AWG14 (2.0 mm ²)	-	-
	Servomotor Main Circuit Cables*	U, V, W	AWG16 (1.25 mm ²)		
	Control Power Supply Cables	L1C, L2C			
	External Regenerative Resistor Cables	B1/⊕, B2			
	Ground cable	⊕	AWG14 (2.0 mm ²) or larger	M4	1.2 to 1.4

* If you do not use the recommended Servomotor Main Circuit Cable, use this table to select wires.

12.3.4 DC Power Supply Wires for Σ -7S SERVOPACKs

SERVOPACK Model: SGD7S-	Terminal Symbols*1		Wire Size	Screw Size	Tightening Torque [N·m]
R70A	Servomotor Main Circuit Cables	U, V, W*2	AWG16 (1.25 mm ²)	-	-
	Control Power Supply Cables	L1C, L2C	AWG16 (1.25 mm ²)	-	-
	Main Circuit Power Supply Cables	B1/⊕, ⊖2	AWG16 (1.25 mm ²)	-	-
	Ground Cable	⊕	AWG14 (2.0 mm ²) or larger	M4	1.2 to 1.4
R90A	Servomotor Main Circuit Cables	U, V, W*2	AWG16 (1.25 mm ²)	-	-
	Control Power Supply Cables	L1C, L2C	AWG16 (1.25 mm ²)	-	-
	Main Circuit Power Supply Cables	B1/⊕, ⊖2	AWG16 (1.25 mm ²)	-	-
	Ground Cable	⊕	AWG14 (2.0 mm ²) or larger	M4	1.2 to 1.4
1R6A	Servomotor Main Circuit Cables	U, V, W*2	AWG16 (1.25 mm ²)	-	-
	Control Power Supply Cables	L1C, L2C	AWG16 (1.25 mm ²)	-	-
	Main Circuit Power Supply Cables	B1/⊕, ⊖2	AWG16 (1.25 mm ²)	-	-
	Ground Cable	⊕	AWG14 (2.0 mm ²) or larger	M4	1.2 to 1.4
2R8A	Servomotor Main Circuit Cables	U, V, W*2	AWG16 (1.25 mm ²)	-	-
	Control Power Supply Cables	L1C, L2C	AWG16 (1.25 mm ²)	-	-
	Main Circuit Power Supply Cables	B1/⊕, ⊖2	AWG16 (1.25 mm ²)	-	-
	Ground Cable	⊕	AWG14 (2.0 mm ²) or larger	M4	1.2 to 1.4
3R8A	Servomotor Main Circuit Cables	U, V, W*2	AWG16 (1.25 mm ²)	-	-
	Control Power Supply Cables	L1C, L2C	AWG16 (1.25 mm ²)	-	-
	Main Circuit Power Supply Cables	B1/⊕, ⊖2	AWG16 (1.25 mm ²)	-	-
	Ground Cable	⊕	AWG14 (2.0 mm ²) or larger	M4	1.2 to 1.4
5R5A	Servomotor Main Circuit Cables	U, V, W*2	AWG16 (1.25 mm ²)	-	-
	Control Power Supply Cables	L1C, L2C	AWG16 (1.25 mm ²)	-	-
	Main Circuit Power Supply Cables	B1/⊕, ⊖2	AWG16 (1.25 mm ²)	-	-
	Ground Cable	⊕	AWG14 (2.0 mm ²) or larger	M4	1.2 to 1.4
7R6A	Servomotor Main Circuit Cables	U, V, W*2	AWG16 (1.25 mm ²)	-	-
	Control Power Supply Cables	L1C, L2C	AWG16 (1.25 mm ²)	-	-
	Main Circuit Power Supply Cables	B1/⊕, ⊖2	AWG16 (1.25 mm ²)	-	-
	Ground Cable	⊕	AWG14 (2.0 mm ²) or larger	M4	1.2 to 1.4

Continued on next page.

12.3 SERVOPACK Main Circuit Wires

12.3.4 DC Power Supply Wires for Σ-7S SERVOPACKs

Continued from previous page.

SERVOPACK Model: SGD7S-	Terminal Symbols*1		Wire Size	Screw Size	Tightening Torque [N·m]
120A (three-phase, 200-VAC input)	Servomotor Main Circuit Cables	U, V, W*2	AWG14 (2.0 mm ²)	–	–
	Control Power Supply Cables	L1C, L2C	AWG16 (1.25 mm ²)	–	–
	Main Circuit Power Supply Cables	B1/⊕, ⊖2	AWG14 (2.0 mm ²)	–	–
	Ground Cable	⊕	AWG14 (2.0 mm ²) or larger	M4	1.2 to 1.4
120A□□□008 (single-phase, 200-VAC input)	Servomotor Main Circuit Cables	U, V, W*2	AWG14 (2.0 mm ²)	M4	1.0 to 1.2
	Control Power Supply Cables	L1C, L2C	AWG16 (1.25 mm ²)	M4	1.0 to 1.2
	Main Circuit Power Supply Cables	B1/⊕, ⊖2	AWG14 (2.0 mm ²)	M4	1.0 to 1.2
	Ground Cable	⊕	AWG14 (2.0 mm ²) or larger	M4	1.2 to 1.4
180A	Servomotor Main Circuit Cables	U, V, W*2	AWG10 (5.5 mm ²)	M4	1.0 to 1.2
	Control Power Supply Cables	L1C, L2C	AWG16 (1.25 mm ²)	M4	1.0 to 1.2
	Main Circuit Power Supply Cables	B1/⊕, ⊖2	AWG10 (5.5 mm ²)	M4	1.0 to 1.2
	Ground Cable	⊕	AWG14 (2.0 mm ²) or larger	M4	1.2 to 1.4
200A	Servomotor Main Circuit Cables	U, V, W*2	AWG10 (5.5 mm ²)	M4	1.0 to 1.2
	Control Power Supply Cables	L1C, L2C	AWG16 (1.25 mm ²)	M4	1.0 to 1.2
	Main Circuit Power Supply Cables	B1/⊕, ⊖2	AWG10 (5.5 mm ²)	M4	1.0 to 1.2
	Ground Cable	⊕	AWG14 (2.0 mm ²) or larger	M4	1.2 to 1.4
330A	Servomotor Main Circuit Cables	U, V, W	AWG8 (8.0 mm ²)	M4	1.0 to 1.2
	Control Power Supply Cables	L1C, L2C	AWG16 (1.25 mm ²)	M4	1.0 to 1.2
	Main Circuit Power Supply Cables	B1/⊕, ⊖2	AWG8 (8.0 mm ²)	M4	1.0 to 1.2
	Ground Cable	⊕	AWG14 (2.0 mm ²) or larger	M4	1.2 to 1.4
470A	Servomotor Main Circuit Cables	U, V, W	AWG6 (14 mm ²)	M5	2.2 to 2.4
	Control Power Supply Cables	L1C, L2C	AWG16 (1.25 mm ²)	M5	2.2 to 2.4
	Main Circuit Power Supply Cables	B1/⊕, ⊖2	AWG8 (8.0 mm ²)	M5	2.2 to 2.4
	Ground Cable	⊕	AWG14 (2.0 mm ²) or larger	M5	2.2 to 2.4
550A	Servomotor Main Circuit Cables	U, V, W	AWG4 (22 mm ²)	M5	2.2 to 2.4
	Control Power Supply Cables	L1C, L2C	AWG16 (1.25 mm ²)	M5	2.2 to 2.4
	Main Circuit Power Supply Cables	B1/⊕, ⊖2	AWG6 (14 mm ²)	M5	2.2 to 2.4
	Ground Cable	⊕	AWG14 (2.0 mm ²) or larger	M5	2.2 to 2.4

Continued on next page.

Continued from previous page.

SERVOPACK Model: SGD7S-	Terminal Symbols* ¹		Wire Size	Screw Size	Tightening Torque [N·m]
590A	Servomotor Main Circuit Cables	U, V, W	AWG4 (22 mm ²)	M6	2.7 to 3.0
	Control Power Supply Cables	L1C, L2C	AWG16 (1.25 mm ²)	M6	2.7 to 3.0
	Main Circuit Power Supply Cables	B1/⊕, ⊖2	AWG3 (30 mm ²)	M6	2.7 to 3.0
	Ground Cable	⊕	AWG14 (2.0 mm ²) or larger	M6	2.7 to 3.0
780A	Servomotor Main Circuit Cables	U, V, W	AWG3 (30 mm ²)	M6	2.7 to 3.0
	Control Power Supply Cables	L1C, L2C	AWG16 (1.25 mm ²)	M6	2.7 to 3.0
	Main Circuit Power Supply Cables	B1/⊕, ⊖2	AWG3 (30 mm ²)	M6	2.7 to 3.0
	Ground Cable	⊕	AWG14 (2.0 mm ²) or larger	M6	2.7 to 3.0

*1. Do not wire the following terminals: L1, L2, L3, B2, B3, ⊖1, and ⊖ terminals.

*2. If you do not use the recommended Servomotor Main Circuit Cable, use this table to select wires.

12.3.5 Three-Phase, 200-VAC Wires for Σ -7W SERVOPACKs and Σ -7C SERVOPACKs

SERVOPACK Model: SGD7W- SGD7C-	Terminal Symbols		Wire Size	Screw Size	Tightening Torque [N·m]
1R6A	Main Circuit Power Supply Cables	L1, L2, L3	AWG16 (1.25 mm ²)	-	-
	Servomotor Main Circuit Cables*	UA, VA, WA, UB, VB, WB			
	Control Power Supply Cables	L1C, L2C			
	External Regenerative Resistor Cables	B1/⊕, B2			
	Ground cable	⊕	AWG14 (2.0 mm ²) or larger	M4	1.2 to 1.4
2R8A	Main Circuit Power Supply Cables	L1, L2, L3	AWG14 (2.0 mm ²)	-	-
	Servomotor Main Circuit Cables*	UA, VA, WA, UB, VB, WB	AWG16 (1.25 mm ²)		
	Control Power Supply Cables	L1C, L2C			
	External Regenerative Resistor Cables	B1/⊕, B2			
	Ground cable	⊕	AWG14 (2.0 mm ²) or larger	M4	1.2 to 1.4
5R5A	Main Circuit Power Supply Cables	L1, L2, L3	AWG14 (2.0 mm ²)	-	-
	Servomotor Main Circuit Cables*	UA, VA, WA, UB, VB, WB	AWG16 (1.25 mm ²)		
	Control Power Supply Cables	L1C, L2C			
	External Regenerative Resistor Cables	B1/⊕, B2	AWG14 (2.0 mm ²)		
	Ground cable	⊕	AWG14 (2.0 mm ²) or larger	M4	1.2 to 1.4
7R6A	Main Circuit Power Supply Cables	L1, L2, L3	AWG14 (2.0 mm ²)	-	-
	Servomotor Main Circuit Cables*	UA, VA, WA, UB, VB, WB	AWG16 (1.25 mm ²)		
	Control Power Supply Cables	L1C, L2C			
	External Regenerative Resistor Cables	B1/⊕, B2	AWG14 (2.0 mm ²)		
	Ground cable	⊕	AWG14 (2.0 mm ²) or larger	M4	1.2 to 1.4

* If you do not use the recommended Servomotor Main Circuit Cable, use this table to select wires.

12.3.6 Single-Phase, 200-VAC Wires for Σ -7W SERVOPACKs and Σ -7C SERVOPACKs

SERVOPACK Model: SGD7W-SGD7C-	Terminal Symbols		Wire Size	Screw Size	Tightening Torque [N·m]
1R6A	Main Circuit Power Supply Cables	L1, L2, L3	AWG16 (1.25 mm ²)	-	-
	Servomotor Main Circuit Cables*	UA, VA, WA, UB, VB, WB			
	Control Power Supply Cables	L1C, L2C			
	External Regenerative Resistor Cables	B1/⊕, B2			
	Ground cable	⊕	AWG14 (2.0 mm ²) or larger	M4	1.2 to 1.4
2R8A	Main Circuit Power Supply Cables	L1, L2, L3	AWG14 (2.0 mm ²)	-	-
	Servomotor Main Circuit Cables*	UA, VA, WA, UB, VB, WB	AWG16 (1.25 mm ²)		
	Control Power Supply Cables	L1C, L2C			
	External Regenerative Resistor Cables	B1/⊕, B2			
	Ground cable	⊕	AWG14 (2.0 mm ²) or larger	M4	1.2 to 1.4
5R5A	Main Circuit Power Supply Cables	L1, L2, L3	AWG14 (2.0 mm ²)	-	-
	Servomotor Main Circuit Cables*	UA, VA, WA, UB, VB, WB	AWG16 (1.25 mm ²)		
	Control Power Supply Cables	L1C, L2C			
	External Regenerative Resistor Cables	B1/⊕, B2	AWG14 (2.0 mm ²)		
	Ground cable	⊕	AWG14 (2.0 mm ²) or larger	M4	1.2 to 1.4

* If you do not use the recommended Servomotor Main Circuit Cable, use this table to select wires.

12.3.7 DC Power Supply Wires for Σ -7W SERVOPACKs

SERVOPACK Model: SGD7W-	Terminal Symbols* ¹		Wire Size	Screw Size	Tightening Torque [N·m]
1R6A	Servomotor Main Circuit Cables	UA, VA, WA, UB, VB, WB* ²	AWG16 (1.25 mm ²)	-	-
	Control Power Supply Cables	L1C, L2C	AWG16 (1.25 mm ²)	-	-
	Main Circuit Power Supply Cables	B1/⊕, ⊖2	AWG16 (1.25 mm ²)	-	-
	Ground Cable	⊕	AWG14 (2.0 mm ²) or larger	M4	1.2 to 1.4

Continued on next page.

Continued from previous page.

SERVOPACK Model: SGD7W-	Terminal Symbols*1		Wire Size	Screw Size	Tightening Torque [N·m]
2R8A	Servomotor Main Circuit Cables	UA, VA, WA, UB, VB, WB*2	AWG16 (1.25 mm ²)	-	-
	Control Power Supply Cables	L1C, L2C	AWG16 (1.25 mm ²)	-	-
	Main Circuit Power Supply Cables	B1/⊕, ⊖2	AWG16 (1.25 mm ²)	-	-
	Ground Cable	⊕	AWG14 (2.0 mm ²) or larger	M4	1.2 to 1.4
5R5A	Servomotor Main Circuit Cables	UA, VA, WA, UB, VB, WB*2	AWG16 (1.25 mm ²)	-	-
	Control Power Supply Cables	L1C, L2C	AWG16 (1.25 mm ²)	-	-
	Main Circuit Power Supply Cables	B1/⊕, ⊖2	AWG14 (2.0 mm ²)	-	-
	Ground Cable	⊕	AWG14 (2.0 mm ²) or larger	M4	1.2 to 1.4
7R6A	Servomotor Main Circuit Cables	UA, VA, WA, UB, VB, WB*2	AWG16 (1.25 mm ²)	-	-
	Control Power Supply Cables	L1C, L2C	AWG16 (1.25 mm ²)	-	-
	Main Circuit Power Supply Cables	B1/⊕, ⊖2	AWG14 (2.0mm ²)	-	-
	Ground Cable	⊕	AWG14 (2.0 mm ²) or larger	M4	1.2 to 1.4

*1. Do not wire the following terminals: L1, L2, L3, B2, B3, ⊖1, and ⊖ terminals.

*2. If you do not use the recommended Servomotor Main Circuit Cable, use this table to select wires.

12.3.8 Wire Types

The following table shows the wire sizes and allowable currents for three bundled leads.

HIV Specifications*		Allowable Current at Surrounding Air Temperatures [Arms]		
Nominal Cross-Sectional Area [mm ²]	Configuration [Wires/mm]	30°C	40°C	50°C
0.9	7/0.4	15	13	11
1.25	7/0.45	16	14	12
2.0	7/0.6	23	20	17
3.5	7/0.8	32	28	24
5.5	7/1.0	42	37	31
8.0	7/1.2	52	46	39
14.0	7/1.6	75	67	56
22.0	7/2.0	98	87	73
38.0	7/2.6	138	122	103

* This is reference data based on JIS C3317 600-V-grade heat-resistant polyvinyl chloride-insulated wires (HIV).





12.4 Crimp Terminals and Insulating Sleeves

If you use crimp terminals for wiring, use insulating sleeves. Do not allow the crimp terminals to come close to adjacent terminals or the case.

To comply with UL standards, you must use UL-compliant closed-loop crimp terminals and insulating sleeves for the main circuit terminals. Use the tool recommended by the crimp terminal manufacturer to attach the crimp terminals.

The following tables give the recommended tightening torques, closed-loop crimp terminals, and insulating sleeves in sets. Use the set that is suitable for your model and wire size.

12.4.1 Σ -7S SERVOPACKs with Three-Phase, 200-VAC or DC Power Supplies

SERVOPACK Model: SGD7S-	Main Circuit Terminals	Screw Size	Tightening Torque [N·m]	Crimp Terminal Horizontal Width	Recommended Wire Size	Crimp Terminal Model	Crimping Tool	Die	Insulating Sleeve Model
						(From J.S.T. Mfg. Co., Ltd.)			(Tokyo Dip Co., Ltd.)
R70A, R90A, 1R6A, 2R8A, 3R8A, 5R5A, 7R6A, or 120A	Connector					-			
		M4	1.2 to 1.4	10 mm max.	AWG14 (2.0 mm ²)	R2-4	YHT-2210	-	-
180A or 200A	Terminal block	M4	1.0 to 1.2	7.7 mm max.	AWG10 (5.5 mm ²)	5.5-S4	YHT-2210	-	TP-005
					AWG14 (2.0 mm ²)	2-M4		-	TP-003
	AWG16 (1.25 mm ²)		-						
		M4	1.2 to 1.4	10 mm max.	AWG14 (2.0 mm ²)	R2-4	YHT-2210	-	-
330A	Terminal block	M4	1.0 to 1.2	9.9 mm max.	AWG8 (8.0 mm ²)	8-4NS	YPT-60N	TD-121 TD-111	TP-008
					AWG14 (2.0 mm ²)	R2-4	YHT-2210	-	TP-003
	AWG16 (1.25 mm ²)		-						
		M4	1.2 to 1.4	10 mm max.	AWG14 (2.0 mm ²)	R2-4	YHT-2210	-	-
470A or 550A	Terminal block	M5	2.2 to 2.4	13 mm max.	AWG4 (22 mm ²)	22-S5	YPT-60N	TD-123 TD-112	TP-022
					AWG6 (14 mm ²)	R14-5		TD-122 TD-111	TP-014
					AWG8 (8.0 mm ²)	R8-5		TD-121 TD-111	TP-008
					AWG10 (5.5 mm ²)	R5.5-5	YHT-2210	-	TP-005
					AWG14 (2.0 mm ²)	R2-5		-	TP-003
	AWG16 (1.25 mm ²)		-						
		M5	2.2 to 2.4	12 mm max.	AWG14 (2.0 mm ²)	R2-5	YHT-2210	-	-

Continued on next page.

12.4 Crimp Terminals and Insulating Sleeves

12.4.2 Σ-7S SERVOPACKs with Single-Phase, 200-VAC

Continued from previous page.

SERVOPACK Model: SGD7S-	Main Circuit Terminals	Screw Size	Tightening Torque [N·m]	Crimp Terminal Horizontal Width	Recommended Wire Size	Crimp Terminal Model	Crimping Tool	Die	Insulating Sleeve Model
						(From J.S.T. Mfg. Co., Ltd.)			(Tokyo Dip Co., Ltd.)
590A or 780A	Terminal block	M6	2.7 to 3.0	18 mm max.	AWG3 (30 mm ²)	38-S6	YPT-60N	TD-124 TD-112	TP-038
					AWG4 (22 mm ²)	R22-6		TD-123 TD-112	TP-022
					AWG8 (8.0 mm ²)	R8-6		TD-121 TD-111	TP-008
					AWG10 (5.5 mm ²)	R5.5-6	YHT-2210	–	TP-005
					AWG14 (2.0 mm ²)	R2-6		–	TP-003
					AWG16 (1.25 mm ²)			–	
⊕	M6	2.7 to 3.0	12 mm max.	AWG14 (2.0 mm ²)	R2-6	YHT-2210	–	–	

12.4.2 Σ-7S SERVOPACKs with Single-Phase, 200-VAC

SERVOPACK Model: SGD7S-	Main Circuit Terminals	Screw Size	Tightening Torque [N·m]	Crimp Terminal Horizontal Width	Recommended Wire Size	Crimp Terminal Model	Crimping Tool	Die	Insulating Sleeve Model
						(From J.S.T. Mfg. Co., Ltd.)			(Tokyo Dip Co., Ltd.)
R70A, R90A, 1R6A, 2R8A, or 5R5A	Connector					–			
	⊕	M4	1.2 to 1.4	10 mm max.	AWG14 (2.0 mm ²)	R2-4	YHT-2210	–	–
120A□□□008	Terminal block	M4	1.0 to 1.2	7.7 mm max.	AWG14 (2.0 mm ²)	2-M4	YHT-2210	–	TP-003
					AWG16 (1.25 mm ²)			–	
	⊕	M4	1.2 to 1.4	10 mm max.	AWG14 (2.0 mm ²)	R2-4	YHT-2210	–	–

12.4.3 Σ-7S SERVOPACKs with Single-Phase, 100-VAC

SERVOPACK Model: SGD7S-	Main Circuit Terminals	Screw Size	Tightening Torque [N·m]	Crimp Terminal Horizontal Width	Recommended Wire Size	Crimp Terminal Model	Crimping Tool	Die	Insulating Sleeve Model
						(From J.S.T. Mfg. Co., Ltd.)			(Tokyo Dip Co., Ltd.)
R70F, R90F, 2R1F, or 2R8F	Connector					–			
	⊕	M4	1.2 to 1.4	10 mm max.	AWG14 (2.0 mm ²)	R2-4	YHT-2210	–	–

12.4.4 Σ -7W SERVOPACKs with Three-Phase, 200-VAC or DC Power Supplies and Σ -7C SERVOPACKs with Three-Phase, 200-VAC

SERVOPACK Model: SGD7W- SGD7C-	Main Circuit Terminals	Screw Size	Tightening Torque [N·m]	Crimp Terminal Horizontal Width	Recommended Wire Size	Crimp Terminal Model	Crimping Tool	Die	Insulating Sleeve Model
						(From J.S.T. Mfg. Co., Ltd.)			(Tokyo Dip Co., Ltd.)
1R6A, 2R8A, 5R5A, or 7R6A	Connector	-							
		M4	1.2 to 1.4	10 mm max.	AWG14 (2.0 mm ²)	R2-4	YHT-2210	-	-

12.4.5 Σ -7W SERVOPACKs and Σ -7C SERVOPACKs with Single-Phase, 200-VAC

SERVOPACK Model: SGD7W- SGD7C-	Main Circuit Terminals	Screw Size	Tightening Torque [N·m]	Crimp Terminal Horizontal Width	Recommended Wire Size	Crimp Terminal Model	Crimping Tool	Die	Insulating Sleeve Model
						(From J.S.T. Mfg. Co., Ltd.)			(Tokyo Dip Co., Ltd.)
1R6A, 2R8A, or 5R5A	Connector	-							
		M4	1.2 to 1.4	10 mm max.	AWG14 (2.0 mm ²)	R2-4	YHT-2210	-	-

Crimp Terminal Dimensional Drawings

- ◆ Crimp Terminal Model: 2-M4, R2-4, R2-5, R2-6, 5.5-S4, R5.5-5, or R5.5-6

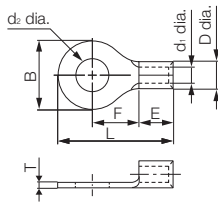

Crimp Terminal Model	Dimensions (mm)							
	d ₂ dia.	B	L	F	E	D dia.	d ₁ dia.	T
2-M4	4.3	6.6	14.4	6.3	4.8	4.1	2.3	0.8
R2-4		8.5	16.8	7.8				
R2-5		9.5	16.8	7.3				
R2-6	6.4	12.0	21.8	11.0	6.2	5.6	3.4	1.0
5.5-S4	4.3	7.2	15.7	5.9				
R5.5-5	5.3	9.5	19.8	8.3				
R5.5-6	6.4	12.0	25.8	13.0	6.8			

◆ Crimp Terminal Model: 8-4NS, R8-5, R8-6, R14-5, 22-S5, R22-6, or 38-S6

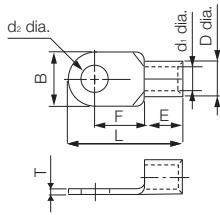

Crimp Terminal Model	Dimensions (mm)							
	d ₂ dia.	B	L	F	E	D dia.	d ₁ dia.	T
8-4NS	4.3	8.0	21.8	9.3	8.5	7.1	4.5	1.2
R8-5	5.3	12.0	23.8					
R8-6	6.4		29.8	13.3	10.5	9.0	5.8	1.5
R14-5	5.3		30.0	12.0	12.0	11.5	7.7	1.8
22-S5	6.4	16.5	33.7	13.5				
R22-6		15.5	38.0	16.0	14.0	13.3	9.4	
38-S6								

12.5 Noise Filter

Noise Filters are used to reduce external noise that can enter on the power supply line or conductive noise from the SERVOPACK.



Important

Some Noise Filters have large leakage currents. The grounding conditions also affect the amount of the leakage current. If necessary, select an appropriate leakage detector or earth leakage breaker taking into account the grounding conditions and the leakage current from the Noise Filter.

Selection Table

◆ Σ-7S SERVOPACKs

Main Circuit Power Supply	SERVOPACK		Order Number	Specification	Mass	Leakage Current	Manufacturer
	Maximum Applicable Motor Capacity [kW]	Model SGD7S-					
Three-phase, 200 VAC	0.05	R70A	HF3010C-SZC	Three-phase, 500 VAC, 10 A	1.0 kg	4 mA 200 VAC /60 Hz	Soshin Electric Co., Ltd.
	0.1	R90A					
	0.2	1R6A					
	0.4	2R8A					
	0.5	3R8A					
	0.75	5R5A	HF3020C-SZC	Three-phase, 500 VAC, 20 A	1.4 kg		
	1.0	7R6A					
	1.5	120A					
	2.0	180A					
	3.0	200A	HF3030C-SZC	Three-phase, 500 VAC, 30 A	1.4 kg		
	5.0	330A	HF3050C-SZC -47EDD	Three-phase, 500 VAC, 50 A	2.0 kg		
	6.0	470A					
	7.5	550A	HF3060C-SZC	Three-phase, 500 VAC, 60 A	2.1 kg		
11	590A	HF3100C-SZC	Three-phase, 500 VAC, 100 A	5.8 kg			
15	780A						
Single-phase, 200 VAC	0.05	R70A	HF2010A-UPF	Single-phase 250 VAC, 10 A	0.5 kg		
	0.1	R90A					
	0.2	1R6A					
	0.4	2R8A					
	0.75	5R5A	HF2020A-UPF -2BB	Single-phase 250 VAC, 20 A	0.8 kg		
1.5	120A□□ □008	HF2030A-UPF -2BB	Single-phase 250 VAC, 30 A	0.8 kg			
Single-phase, 100 VAC	0.05	R70F	HF2010A-UPF	Single-phase 250 VAC, 10 A	0.5 kg		
	0.1	R90F					
	0.2	2R1F					
	0.4	2R8F	HF2020A-UPF	Single-phase 250 VAC, 20 A	0.8 kg		

◆ Σ-7W SERVOPACKs and Σ-7C SERVOPACKs

Main Circuit Power Supply	SERVOPACK		Order Number	Specification	Mass	Leakage Current	Manufacturer
	Maximum Applicable Motor Capacity [kW]	Model SGD7W-SGD7C-					
Three-phase, 200 VAC	0.2	1R6A	HF3010C-SZC	Three-phase, 500 VAC, 10 A	1.0 kg	4 mA 200 VAC /60 Hz	Soshin Electric Co., Ltd.
	0.4	2R8A	HF3020C-SZC	Three-phase, 500 VAC, 20 A	1.4 kg		
	0.75	5R5A					
	1.0	7R6A					
Single-phase, 200 VAC	0.2	1R6A	HF2010A-UPF	Single-phase 250 VAC, 10 A	0.5 kg	1.2 mA 250 VAC /60 Hz	
	0.4	2R8A	HF2020A-UPF -2BB	Single-phase 250 VAC, 20 A	0.8 kg	3 mA 250 VAC /60 Hz	
	0.75	5R5A	HF2030A-UPF -2BB	Single-phase 250 VAC, 30 A	0.8 kg		

External Dimensions

◆ Model: HF3010C-SZC, HF3020C-SZC, or HF3030C-SZC

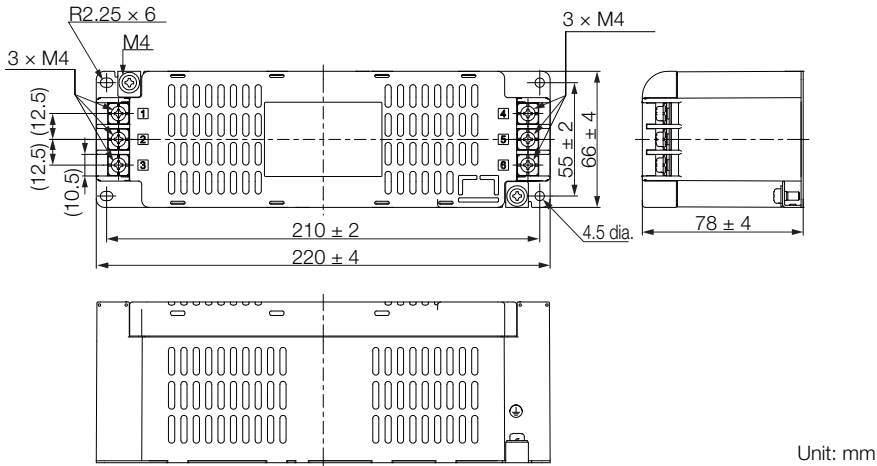

◆ Model: HF3050C-SZC-47EDD or HF3060C-SZC

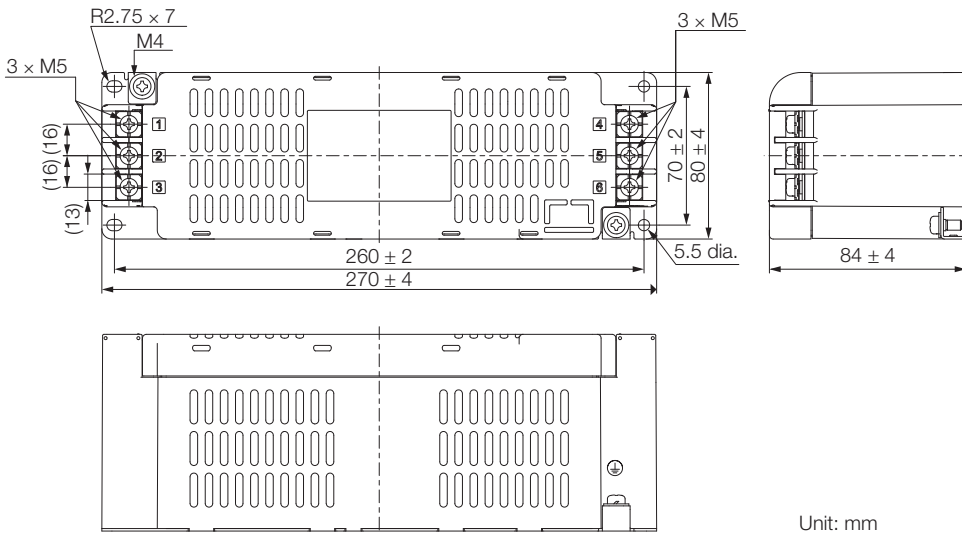

◆ Model: HF3100C-SZC

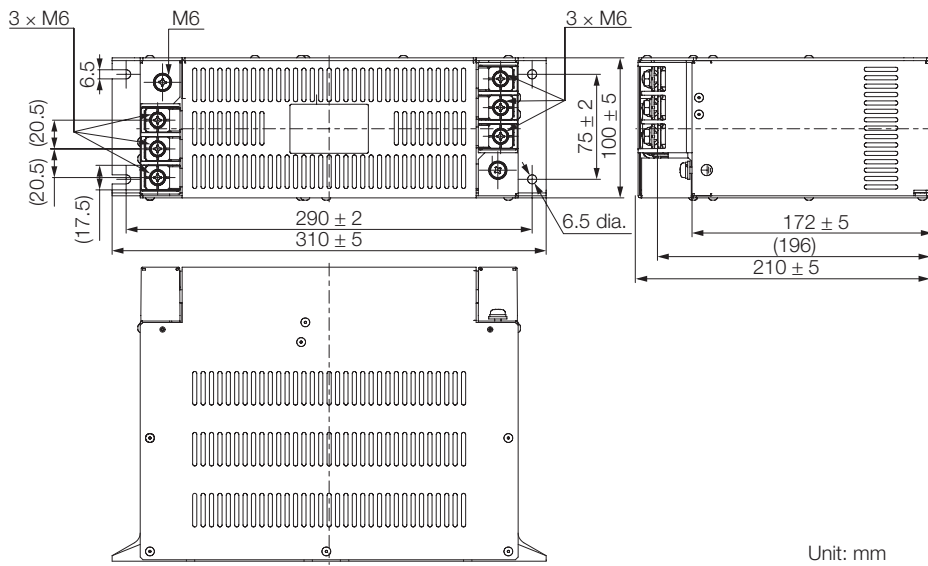

◆ Model: HF2010A-UPF

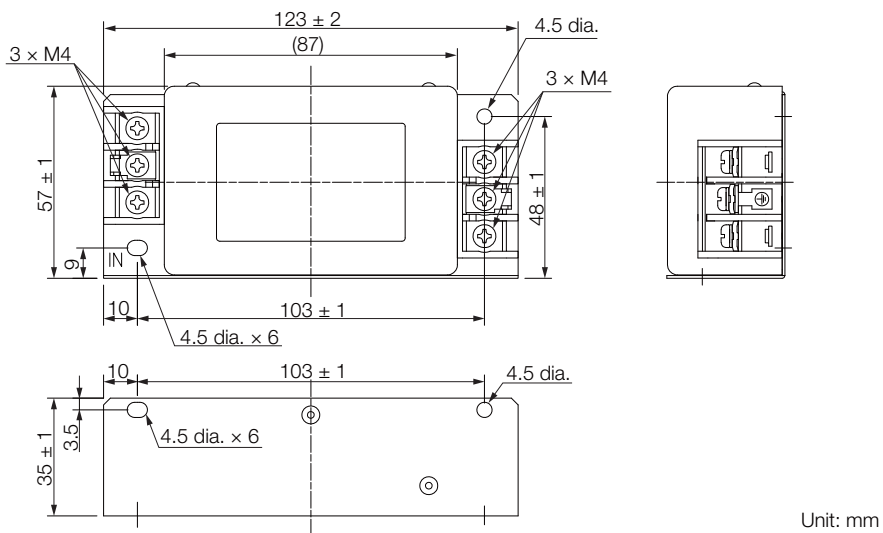

◆ Model: HF2020A-UPF, HF2020A-UPF-2BB, or HF2030A-UPF-2BB

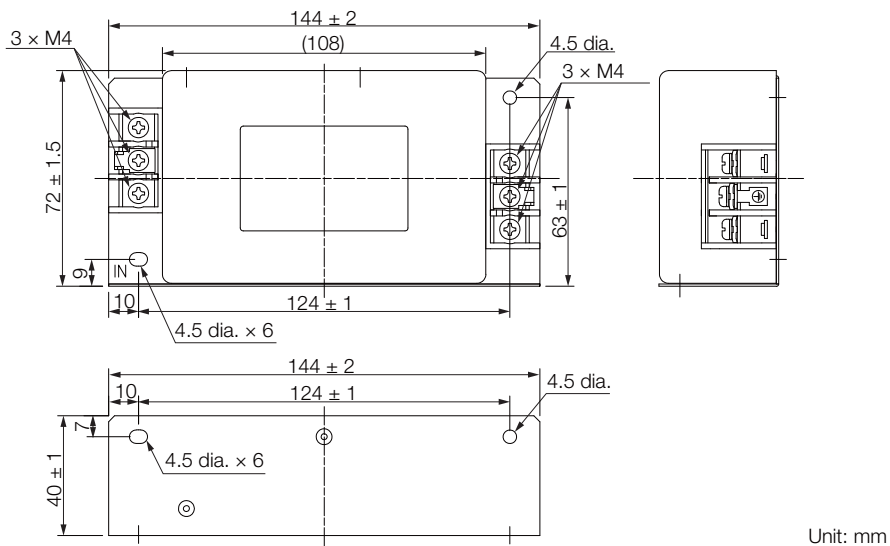

12.6 AC/DC Reactors

Use the Reactors listed in the following tables if harmonic suppression is required.

12.6.1 Using a Three-Phase, 200-VAC Power Supply Input

Selection Table

◆ Σ-7S SERVOPACKs

SERVOPACK		DC Reactor					
Maximum Applicable Motor Capacity [kW]	Model SGD7S-	Order Number	Inductance [mH]	Rated Current [Arms]	Mass	Terminal Screw Size	Wire Size
0.05	R70A	X5061	2.0	4.8	0.5 kg	M4	AWG16 (1.25 mm ²)
0.1	R90A						
0.2	1R6A						
0.4	2R8A						
0.5	3R8A						
0.75	5R5A						
1.0	7R6A						
1.5	120A	X5060	1.5	8.8	1.0 kg	M4	AWG14 (2.0 mm ²)
2.0	180A	X5059	1.0	14.0	1.1 kg	M5	AWG10 (5.5 mm ²)
3.0	200A						
5.0	330A	X5068	0.47	26.8	1.9 kg	M6	AWG8 (8.0 mm ²)
6.0	470A	X008025	0.49	28.3	2.6 kg	M6	AWG8 (8.0 mm ²)
7.5	550A	X008026	0.43	35.5	2.9 kg	M6	AWG6 (14.0 mm ²)
11	590A	X008027	0.32	49.7	3.5 kg	M6	AWG3 (30.0 mm ²)
15	780A	X008028	0.26	72.6	4.0 kg	M6	

◆ Σ-7W SERVOPACKs and Σ-7C SERVOPACKs

SERVOPACK		DC Reactor					
Maximum Applicable Motor Capacity [kW]	Model SGD7W-SGD7C-	Order Number	Inductance [mH]	Rated Current [Arms]	Mass	Terminal Screw Size	Wire Size
0.2	1R6A	X5061	2.0	4.8	0.5 kg	M4	AWG16 (1.25 mm ²)
0.4	2R8A						
0.75	5R5A	X5060	1.5	8.8	1.0 kg	M4	AWG14 (2.0 mm ²)
1.0	7R6A						AWG10 (5.5 mm ²)

12.6.2 Using a Single-Phase, 200-VAC Power Supply Input

Selection Table

◆ Σ -7S SERVOPACKs

SERVOPACK		DC Reactor					
Maximum Applicable Motor Capacity [kW]	Model SGD7S-	Order Number	Inductance [mH]	Rated Current [Arms]	Mass	Terminal Screw Size	Wire Size
0.05	R70A	X5071	40.0	0.85	0.5 kg	M4	AWG16 (1.25 mm ²)
0.1	R90A						
0.2	1R6A	X5070	20.0	1.65	0.8 kg	M4	
0.4	2R8A	X5069	10.0	3.3	1.0 kg	M4	
0.75	5R5A	X5079	4.0	5.3	1.2 kg	M4	
1.5	120A□□□08	X5078	2.5	10.5	2.0 kg	M5	AWG14 (2.0 mm ²)

◆ Σ -7W SERVOPACKs and Σ -7C SERVOPACKs

SERVOPACK		DC Reactor					
Maximum Applicable Motor Capacity [kW]	Model SGD7S-	Order Number	Inductance [mH]	Rated Current [Arms]	Mass	Terminal Screw Size	Wire Size
0.2	1R6A	X5069	10.0	3.3	1.0 kg	M4	AWG16 (1.25 mm ²)
0.4	2R8A	X5079	4.0	5.3	1.2 kg	M4	
0.75	5R5A	X5078	2.5	10.5	2.0 kg	M5	AWG14 (2.0 mm ²)

12.6.3 Using a Single-Phase, 100-VAC Power Supply Input

Selection Table

◆ Σ -7S SERVOPACKs

SERVOPACK		AC Reactor					
Maximum Applicable Motor Capacity [kW]	Model SGD7S-	Order Number	Inductance [mH]	Rated Current [Arms]	Mass	Terminal Screw Size	Wire Size
0.05	R70F	X5053	20.0	2.0	0.6 kg	M4	AWG16 (1.25 mm ²)
0.1	R90F						
0.2	2R1F	X5054	5.0	3.0	0.4 kg	M4	
0.4	2R8F	X5056	2.0	5.0	0.4 kg	M4	

12.6.4 External Dimensions

External Dimensions

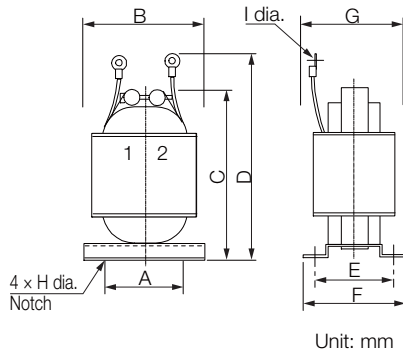

AC/DC Reactor Order Number	External Dimensions [mm]									Approx. Mass [kg]
	A	B	C	D	E	F	G	H	I	
X5053	35	52	90	105	35	45	50	4	4.3	0.6
X5054	35	52	80	95	30	40	45	4	4.5	0.4
X5056	35	52	80	95	30	40	45	4	4.3	0.4
X5059	50	74	125	140	35	45	60	5	5.3	1.1
X5060	40	59	105	125	45	60	65	4	4.3	1.0
X5061	35	52	80	95	35	45	50	4	4.3	0.5
X5068	50	74	125	155	53	66	75	5	6.4	1.9
X5069	40	59	105	125	45	60	65	4	4.3	1.0
X5070	40	59	100	120	35	45	50	4	4.3	0.8
X5071	35	52	80	95	30	40	45	4	4.3	0.5
X5078	50	74	125	155	60	70	80	5	5.3	2.0
X5079	50	74	125	140	35	45	60	5	4.3	1.2
X008025	75	95	155	225	55	70	76	4.5	6.4	2.6
X008026	75	95	155	225	60	75	81	4.5	6.4	2.9
X008027	75	95	155	215	70	85	91	4.5	6.4	3.5
X008028	75	95	160	225	80	95	101	4.5	6.4	4.0

12.7 Surge Absorbers

A Surge Absorber absorbs lightning surge voltages and other abnormal voltages from the power supply input line to prevent faulty operation in or damage to electronic circuits.

Selection Table

Main Circuit Power Supply	SERVOPACK Model:		Order Number (Recommended Product)	Manufacturer
	SGD7S-	SGD7W-SGD7C-		
Three-phase, 200 VAC	□□□A	□□□A	LT-C32G801WS	Soshin Electric Co., Ltd.
Single-phase, 200 VAC	□□□A	□□□A	LT-C12G801WS	
Single-phase, 100 VAC	□□□F	-		

External Dimensions

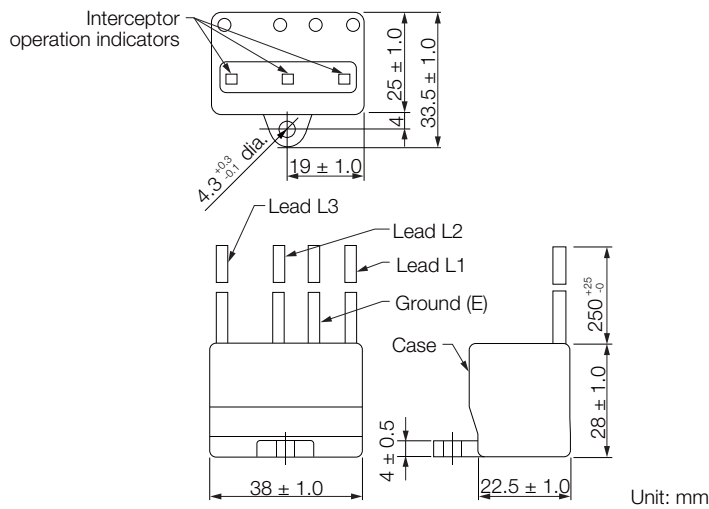

* The LT-C12G801WS does not have lead L2.

Note: The wire size for all of the leads (L1, L2, and L3) and the ground wire (E) is AWG16 (UL1015).

Internal Cables Connections

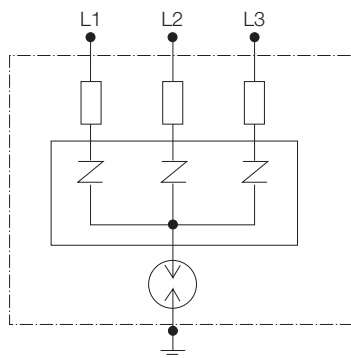

12.8 Regenerative Resistor

If the regenerative power exceeds the amount that can be absorbed by charging the smoothing capacitor, a regenerative resistor is used.

12.8.1 Regenerative Power and Regenerative Resistance

The rotational energy of a driven machine such as a Servomotor that is returned to the SERVOPACK is called regenerative power. The regenerative power is absorbed by charging a smoothing capacitor. When the regenerative power exceeds the capacity of the capacitor, it is consumed by a regenerative resistor. (This is called resistance regeneration.)

The Servomotor is driven in a regeneration state in the following circumstances:

- While decelerating to a stop during acceleration/deceleration operation.
- While performing continuous downward operation on a vertical axis.
- During continuous operation in which the Servomotor is rotated by the load (i.e., a negative load).



Important

You cannot use the resistance regeneration provided by the SERVOPACK for continuous regeneration. For continuous operation with a negative load, you must design a system that also includes a Power Regenerative Converter or Power Regenerative Unit (for example, Yaskawa model D1000 or R1000). If regenerative power is not appropriately processed, the regenerative energy from the load will exceed the allowable range and damage the SERVOPACK. Examples of negative loads are shown below.

- Motor Drive to Lower Objects without a Counterweight
- Motor Drive for Feeding

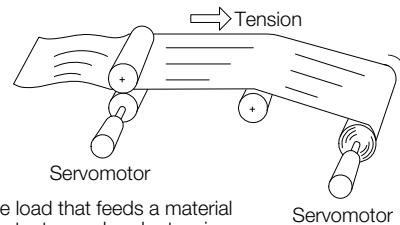
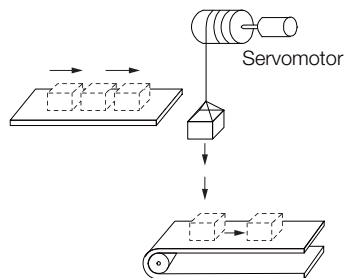

Negative load that feeds a material at a constant speed under tension

12.8.2 Types of Regenerative Resistors

The following regenerative resistors can be used.

- Built-in regenerative resistor: A regenerative resistor that is built into the SERVOPACK. Not all SERVOPACKs have built-in regenerative resistors.
- External Regenerative Resistor: A regenerative resistor that is connected externally to SERVOPACK. These resistors are used when the smoothing capacitor and built-in regenerative resistor in the SERVOPACK cannot consume all of the regenerative power.

Note: If you use an External Regenerative Resistor, you must change the setting of Pn600 (Regenerative Resistor Capacity) and Pn603 (Regenerative Resistance).

12.8.3 Selection Table

SERVOPACK Model		Built-In Regenerative Resistor	External Regenerative Resistor	Description
SGD7S-	SGD7W-SGD7C-			
R70A, R90A, 1R6A, 2R8A, R70F, R90F, 2R1F, or 2R8F	–	Not provided.	Basically not required.	There is no built-in regenerative resistor, but normally an External Regenerative Resistor is not required. Install an External Regenerative Resistor when the smoothing capacitor in the SERVOPACK cannot consume all the regenerative power.
3R8A, 5R5A, 7R6A, 120A, 180A, 200A, or 330A	1R6A, 2R8A, 5R5A, or 7R6A	Standard feature* ¹	Basically not required.	A built-in regenerative resistor is provided as a standard feature. Install an External Regenerative Resistor when the built-in regenerative resistor cannot process all of the regenerative power.
470A, 550A, 590A, or 780A	–	Not provided.	Required.* ²	A built-in regenerative resistor is not provided. An External Regenerative Resistor is required. If the External Regenerative Resistor is not connected to the SERVOPACK, a Regeneration Alarm (A.300) will occur.

*1. Refer to the following section for the specifications of built-in regenerative resistors.

 12.8.4 Specifications of Built-in Regenerative Resistors in SERVOPACKs on page 12-33

*2. Regenerative Resistor Units are available. Refer to the following section for details.

 Regenerative Resistor Units on page 12-36

12.8.4 Specifications of Built-in Regenerative Resistors in SERVOPACKs

The following table gives the specifications of the built-in regenerative resistors in the SERVOPACKs and the amount of regenerative power (average values) that they can process.

SERVOPACK Model		Built-In Regenerative Resistor		Regenerative Power Processing Capacity of Built-in Regenerative Resistor [W]	Minimum Allowable Resistance [Ω]
SGD7S-	SGD7W-SGD7C-	Resistance [Ω]	Capacity [W]		
R70A, R90A, 1R6A, 2R8A, R70F, R90F, 2R1F, or 2R8F	–	–	–	–	40
3R8A, 5R5A, or 7R6A	1R6A or 2R8A	40	40	8	40
120A	–	20	60	12	20
120A□□□008, 180A, or 200A	5R5A or 7R6A	12	60	12	12
330A	–	8	180	36	8
470A	–	(6.25)* ¹	(880)* ¹	(180)* ¹	5.8
550A, 590A, or 780A	–	(3.13)* ²	(1760)* ²	(350)* ²	2.9

*1. Values in parentheses are for the optional JUSP-RA04-E Regenerative Resistor Unit.

*2. Values in parentheses are for the optional JUSP-RA05-E Regenerative Resistor Unit.

12.8.5 Specifications and Dimensions of External Regenerative Resistors

Selection Table

Model	Specification	Mass	Wire Size	Manufacturer
RH120	70 W, 1 Ω to 100 Ω	282 g	AWG16 (1.25 mm ²)	Iwaki Musen Kenkyusho Co., Ltd.
RH150	90 W, 1 Ω to 100 Ω	412 g	AWG14 (2.0 mm ²)	
RH220	120 W, 1 Ω to 100 Ω	500 g	AWG16 (1.25 mm ²)	
RH220B	120 W, 1 Ω to 100 Ω	495 g	AWG14 (2.0 mm ²)	
RH300C	200 W, 1 Ω to 10 kΩ	850 g	AWG14 (2.0 mm ²)	
RH450	150 W, 1 Ω to 100 Ω	880 g	AWG14 (2.0 mm ²)	
RH450FY	150 W, 2 Ω to 100 Ω	1.3 kg	AWG14 (2.0 mm ²)	
RH500	300 W, 2 Ω to 50 Ω	1.4 kg	AWG14 (2.0 mm ²)	

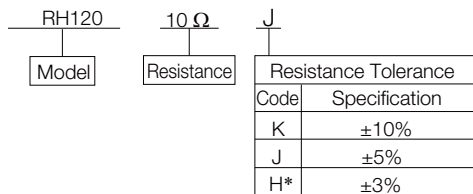

* An External Regenerative Resistor with resistance tolerance H (±3%) is not available for the RH450FY.

Specification

Item	Specification
Resistance Tolerance	K: ±10%, J: ±5%, H: ±3%
Temperature Resistance Characteristics	At less than 20 Ω: ±400 PPM/°C, At 20 Ω or higher: ±260 PPM/°C
Withstand Voltage	2,000 VAC/1 min, ΔR: ±(0.1% + 0.05 Ω)
Insulation Resistance	500 VDC, 20 MΩ min.
Short-Duration Overload	10 times the rated power applied for 5 s: ΔR: ±(2% + 0.05 Ω)
Service Life	1,000 hours at ratings, 90 min ON, 30 min OFF: ΔR: ±(5% + 0.05 Ω)
Flame Resistance	There must be no ignition when 10 times the rated power is applied for 1 min.
Surrounding Air Temperature Range	-25°C to 150°C

External Dimensions

◆ Model: RH120, RH150, or RH220

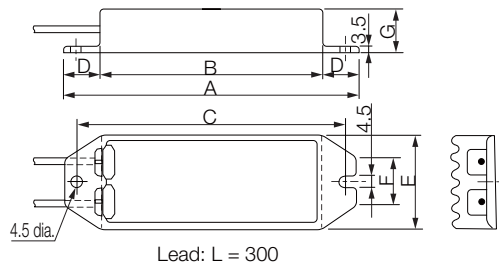

Model	Rated Power	Resistance Range	Wire Size
RH120	70 W	1 Ω to 100 Ω	AWG16 (1.25 mm ²)
RH150	90 W		AWG14 (2.0 mm ²)
RH220	120 W		AWG16 (1.25 mm ²)

External Dimensions (Unit: mm)							Mass
A	B	C	D	E	F	G	
182	150	172	16	42	22	20	282 g
212	180	202	16	44	24	30	412 g
230	200	220	15	60	24	20	500 g

◆ Model: RH220B

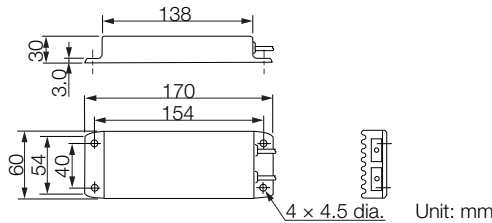

Lead: L = 500
 Rated power: 120 W
 Resistance range: 1 Ω to 100 Ω
 Wire size: AWG14 (2.0 mm²)
 Mass: 495 g

◆ Model: RH300C

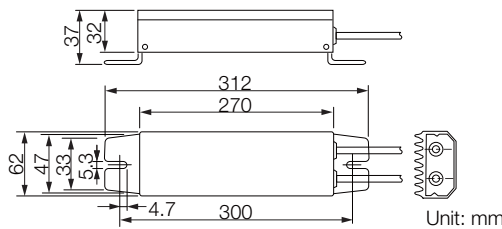

Lead: L = 300
 Rated power: 200 W
 Resistance range: 1 Ω to 10 kΩ
 Wire size: AWG14 (2.0 mm²)
 Mass: 850 g

◆ Model: RH450

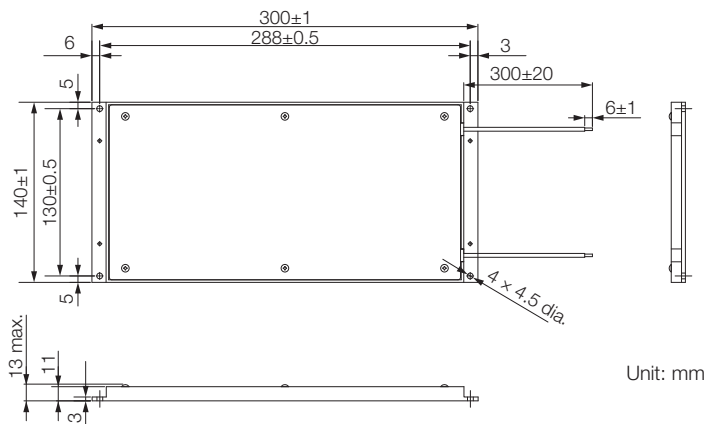

Lead: L = 300
 Rated power: 150 W
 Resistance range: 1 Ω to 100 Ω
 Wire size: AWG14 (2.0 mm²)
 Mass: 880 g

◆ Model: RH450FY

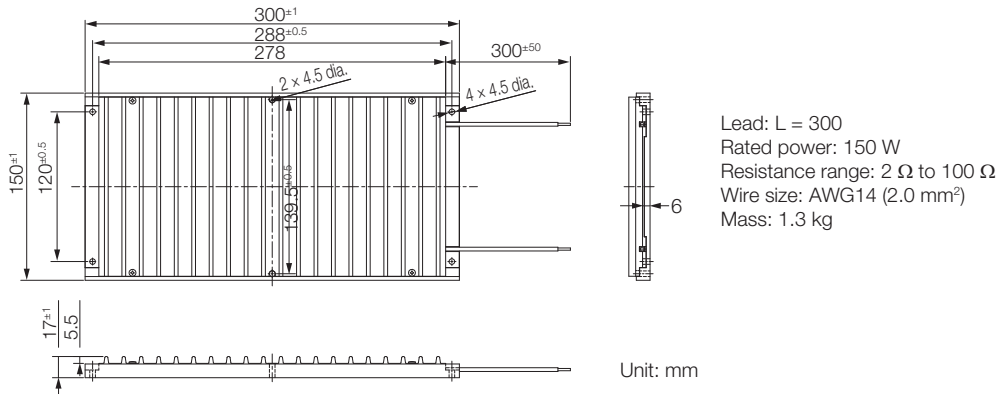

◆ Model: RH500

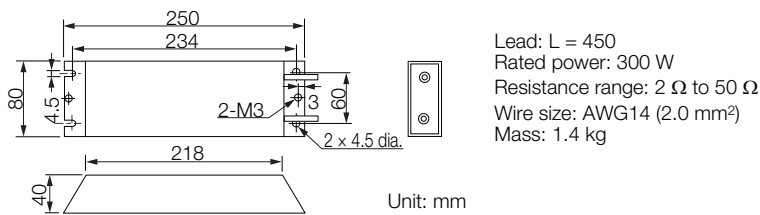

Regenerative Resistor Units

SERVOPACK Model: SGD7S-	Regenerative Resistor Unit Model	Specification	Allowable Power Loss
470A	JUSP-RA04-E	6.25 Ω, 880 W	180 W
550A, 590A, or 780A	JUSP-RA05-E	3.13 Ω, 1760 W	350 W

Note: If you use only the above Regenerative Resistor Units, you do not need to change the setting of Pn600 (Regenerative Resistor Capacity) or Pn603 (Regenerative Resistance).

◆ External Dimensions

■ JUSP-RA04-E

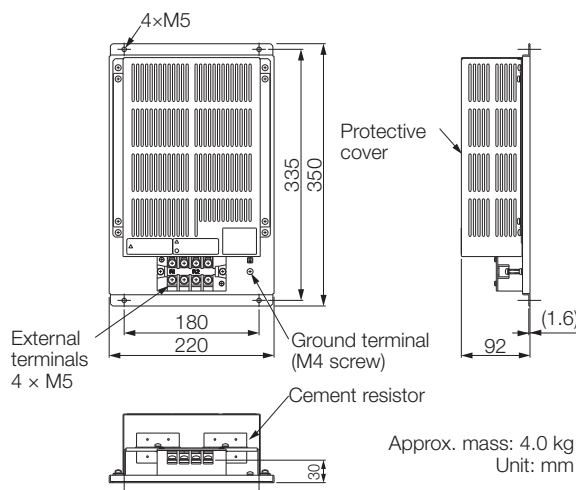

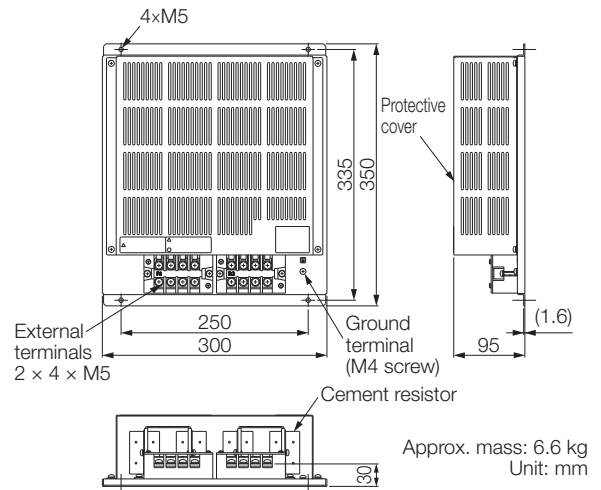

■ JUSP-RA05-E



12.8.6 Selecting External Regenerative Resistor

You can use one of two methods to manually calculate whether an External Regenerative Resistor is required. Refer to the following sections.

 *Simple Calculation* on page 12-37

 *Calculating the Regenerative Energy* on page 12-42

Simple Calculation

When driving a Servomotor with a horizontal shaft, check if an External Regenerative Resistor is required using the following calculation method. The calculation method depends on the model of the SERVOPACK.

◆ SERVOPACK Models SGD7S-R70A, -R90A, -1R6A, -2R8A, -R70F, -R90F, -2R1F, and -2R8F

Regenerative resistors are not built into the above SERVOPACKs. The total amount of energy that can be charged in the capacitors is given in the following table.

If the rotational energy (E_S) of the Servomotor and load exceeds the processable regenerative energy, then connect an External Regenerative Resistor.

Applicable SERVOPACK		Processable Regenerative Energy (Joules)	Remarks
SGD7S-	R70A, R90A, 1R6A	24.2	Value when main circuit input voltage is 200 VAC
	2R8A	31.7	
	R70F, R90F, 2R1F	28.6	Value when main circuit input voltage is 100 VAC
	2R8F	48.4	

Calculate the rotational energy (E_S) of the servo system with the following equation:

$$E_S = J \times (n_M)^2 / 182 \text{ (Joules)}$$

- $J = J_M + J_L$
- J_M : Servomotor moment of inertia ($\text{kg}\cdot\text{m}^2$)
- J_L : Load moment of inertia at motor shaft ($\text{kg}\cdot\text{m}^2$)
- n_M : Servomotor operating motor speed (min^{-1})

- ◆ **SERVOPACK Model: SGD7S-3R8A, -5R5A, -7R6A, -120A, -180A, -200A, -330A, -470A, -550A, -590A, or -780A**
SGD7W-1R6A, -2R8A, -5R5A, or -7R6A
SGD7C-1R6A, -2R8A, -5R5A, or -7R6A

The above SERVOPACKs require regenerative resistors. Regenerative resistors are built into all of the SERVOPACKs in advance except for the SGD7S-470A, -550A, -590A, and -780A. If you use the SGD7S-470A, -550A, -590A, or -780A, always provide an external regenerative resistor. Refer to the following section for details.

📖 12.8.3 Selection Table on page 12-33

The allowable frequencies for regenerative operation of the Servomotor without a load in acceleration/deceleration operation during an operation cycle from 0 (min⁻¹) to the maximum motor speed and back to 0, are listed below. For the SGD7S-470A, -550A, -590A, and -780A, the allowable frequencies are given for when a Regenerative Resistor Unit is connected. Refer to the following section for details on Regenerative Resistor Units.

📖 Regenerative Resistor Units on page 12-36

Convert the data into the values for the actual motor speed and load moment of inertia to determine whether an External Regenerative Resistor is required.

■ Rotary Servomotors

Servomotor Model		Allowable Frequencies in Regenerative Operation (Rotations/Min)	
		SERVOPACK Model: SGD7S	SERVOPACK Model: SGD7W or SGD7C (Simultaneous Operation of Two Axes)
SGM7M-	A1A	-	-
	A2A	-	-
	A3A	-	-
SGM7J-	A5A	-	300
	01A	-	180
	C2A	-	130
	02A	-	46
	04A	-	25
	06A	30	30
	08A	15	15
SGM7A-	A5A	-	560
	01A	-	360
	C2A	-	260
	02A	-	87
	04A	-	56
	06A	77	77
	08A	31	31
	10A	31	-
	15A	15	-
	20A	19	-
	25A	15	-
	30A	6.9	-
	40A	11	-
	50A	8.8	-
70A	86	-	

Servomotor Model		Allowable Frequencies in Regenerative Operation (Rotations/Min)	
		SERVOPACK Model: SGD7S	SERVOPACK Model: SGD7W or SGD7C (Simultaneous Operation of Two Axes)
SGM7P-	01A	-	200
	02A	-	46
	04A	-	29
	08A	11	11
	15A	7.5	-
SGM7G-	03A	39	39
	05A	29	29
	09A	6.9	6.9
	13A	6.1	-
	20A	7.4	-
	30A	9.5	-
	44A	6.4	-
	55A	24	-
	75A	34	-
1AA	39	-	
1EA	31	-	
SGMMV-	A1A	-	-
	A2A	-	-
	A3A	-	-

■ Direct Drive Servomotors

Servomotor Model		Allowable Frequencies in Regenerative Operation (Rotations/Min)	
		SERVOPACK Model: SGD7S	SERVOPACK Model: SGD7W or SGD7C (Simultaneous Operation of Two Axes)
SGM7D-	01G	-	-
	1AF	120	-
	1CI	74	-
	1ZI	91	-
	02K	-	-
	03H	-	-
	05G	-	-
	06J	350	-
	06L	-	-
	07K	-	-
	08G	430	-
	08K	-	-
	09J	250	-
	12L	-	-
	18G	350	-
	18J	210	-
	20J	200	-
	24G	270	-
	28I	52	-
	2BI	89	-
	2DI	110	-
	30F	210	-
	30L	63	-
	38J	150	-
34G	220	-	
45G	190	-	
58F	170	-	
70I	100	-	
90F	140	-	
SGM7E-	02B	-	62
	05B	-	34
	07B	-	22
	04C	-	22
	08D	-	6.1
	10C	-	19
	14C	-	22
	17D	-	7
	25D	-	9.3
	16E	3.7	3.7
	35E	9.7	9.7

Servomotor Model		Allowable Frequencies in Regenerative Operation (Rotations/Min)		
		SERVOPACK Model: SGD7S	SERVOPACK Model: SGD7W or SGD7C (Simultaneous Operation of Two Axes)	
SGM7F-	02A	-	150	
	05A	-	83	
	04B	-	75	
	08C	-	21	
	10B	-	48	
	14B	65	65	
	16D	13	13	
	17C	30	30	
	25C	31	31	
	35D	19	19	
	45M	25	25	
	80M	19	-	
	1AM	8.9	-	
	80N	22	-	
	1EN	11	-	
	2ZN	9.1	-	
	SGM7CV-	04B	-	75
		08C	-	21
		10B	-	48
14B		65	65	
16D		13	13	
17C		30	30	
25C		31	31	
35D	19	19		
SGM7CS-	02B	-	62	
	05B	-	34	
	07B	-	22	
	04C	-	22	
	08D	-	6.1	
	10C	-	19	
	14C	-	22	
	17D	-	7	
	25D	-	9.3	
	16E	3.7	3.7	
	35E	9.7	9.7	
	45M	25	25	
	80M	19	-	
80N	8.9	-		
1AM	22	-		
1EN	11	-		
2ZN	9.1	-		

■ Linear Servomotors

Servomotor Model		Allowable Frequencies in Regenerative Operation (Rotations/Min)	
		SERVO-PACK Model: SGD7S	SERVOPACK Model: SGD7W or SGD7C (Simultaneous Operation of Two Axes)
SGLGW- Using a Standard-Force Magnetic Way	30A050C	-	190
	30A080C	-	120
	40A140C	-	56
	40A253C	-	32
	40A365C	-	22
	60A140C	-	49
	60A253C	-	27
	60A365C	37	37
	90A200C	34	-
	90A370C	33	-
SGLGW- Using a High-Force Magnetic Way	40A140C	-	80
	40A253C	-	45
	40A365C	62	62
	60A140C	-	64
	60A253C	71	71
	60A365C	49	49
SGLFW2-	30A070A	-	38
	30A120A	-	21
	30A230A	22	11
	45A200A	16	16
	45A380A	10*1	-
		17*2	-
	90A200A	14	-
	90A380A	11	-
	90A560A	18	-
	1DA380A	21	-
1DA560A	32	-	

Servomotor Model		Allowable Frequencies in Regenerative Operation (Rotations/Min)	
		SERVOPACK Model: SGD7S	SERVOPACK Model: SGD7W or SGD7C (Simultaneous Operation of Two Axes)
SGLFW-	20A090A	-	27
	20A120A	-	21
	35A120A	-	14
	35A230A	16	16
	50A200B	10	10
	50A380B	6.9	-
	1ZA200B	7.8	-
	1ZA380B	6.6	-
SGLTW-	20A170A	15	15
	20A320A	8.3	8.3
	20A460A	7.1	-
	35A170A	10	10
	35A170H	8.5	8.5
	35A320A	7	-
	35A320H	5.9	-
	35A460A	7.6	-
	40A400B	13	-
	40A600B	19	-
50A170H	15	15	

*1. This value is in combination with the SGD7S-120A.

*2. This value is in combination with the SGD7S-180A.

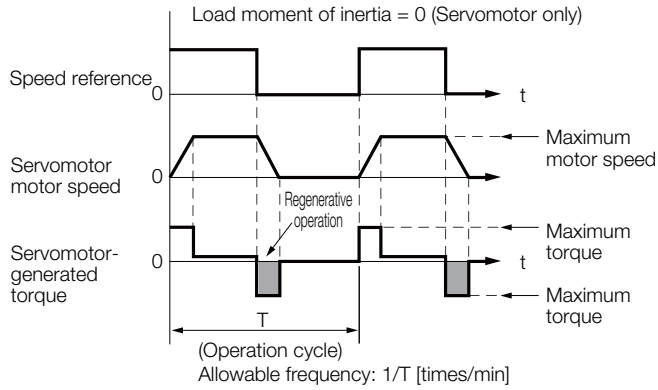

Operating Conditions for Calculating the Allowable Regenerative Frequency

Use the following equation to calculate the allowable frequency for regenerative operation.

$$\text{Allowable frequency} = \frac{\text{Allowable frequency for regenerative operation for Servomotor without load}}{(1+n)} \times \left(\frac{\text{Maximum motor speed}}{\text{Operating motor speed}} \right)^2 \text{ (time/min)}$$

- $n = J_L/J_M$
- J_M : Servomotor moment of inertia ($\text{kg}\cdot\text{m}^2$)
- J_L : Load moment of inertia at motor shaft ($\text{kg}\cdot\text{m}^2$)

Calculating the Regenerative Energy

This section shows how to calculate the regenerative resistor capacity for the acceleration/deceleration operation shown in the following figure.

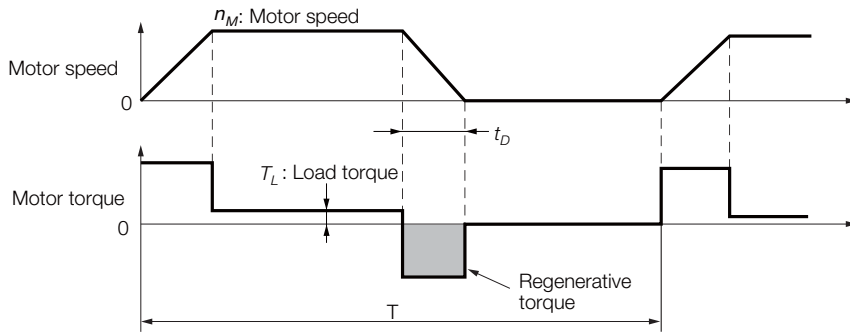

• Calculation Procedure for Regenerative Resistor Capacity

Step	Item	Symbol	Formula
1	Calculate the rotational energy of the Servomotor.	E_S	$E_S = Jn_M^2/182$
2	Calculate the energy consumed by load loss during the deceleration period	E_L	$E_L = (\pi/60) n_M T_L t_D$ Note: If the load loss is unknown, calculate the value with E_L set to 0.
3	Calculate the energy lost from Servomotor winding resistance.	E_M	(Value calculated from the graphs in ◆ Servomotor Winding Resistance Loss on page 12-44) $\times t_D$
4	Calculate the energy that can be absorbed by the SERVOPACK.	E_C	Calculate from the graphs in ◆ SERVOPACK-absorbable Energy on page 12-43
5	Calculate the energy consumed by the regenerative resistor.	E_K	$E_K = E_S - (E_L + E_M + E_C)$
6	Calculate the required regenerative resistor capacity (W).	W_K	$W_K = E_K/(0.2 \times T)$

Note: 1. The 0.2 in the equation for calculating W_K is the value when the regenerative resistor’s utilized load ratio is 20%.

2. The units for the various symbols are given in the following table.

Symbol	Description	Symbol	Description
E_S to E_K	Energy in joules (J)	T_L	Load torque (N·m)
W_K	Required regenerative resistor capacity (W)	t_D	Deceleration stopping time (s)
J	$= J_M + J_L$ (kg·m ²)	T	Servomotor repeat operation cycle (s)
n_M	Servomotor motor speed (min ⁻¹)		

If the value of W_K does not exceed the capacity of the built-in regenerative resistor of the SERVOPACK, an External Regenerative Resistor is not required. For details on the built-in regenerative resistors, refer to the SERVOPACK specifications. If the value of W_K exceeds the capacity of the built-in regenerative resistor, install an External Regenerative Resistor with a capacity equal to the value for W calculated above.

◆ **SERVOPACK-absorbable Energy**

The following figures show the relationship between the SERVOPACK's input power supply voltage and its absorbable energy.

■ **Σ-7S SERVOPACKs**

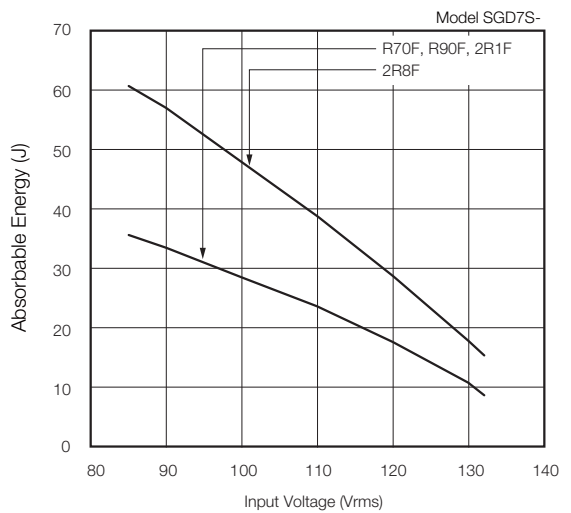
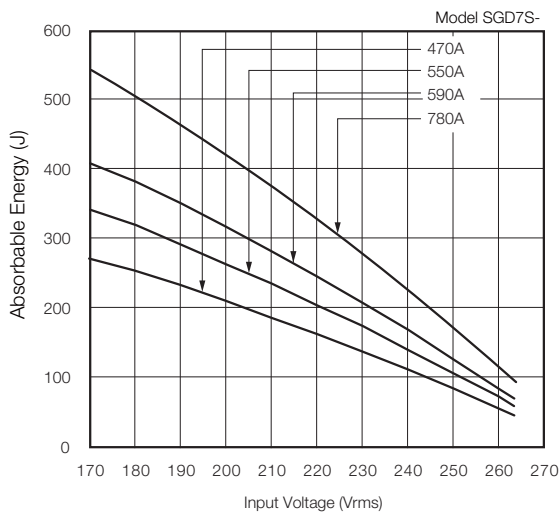
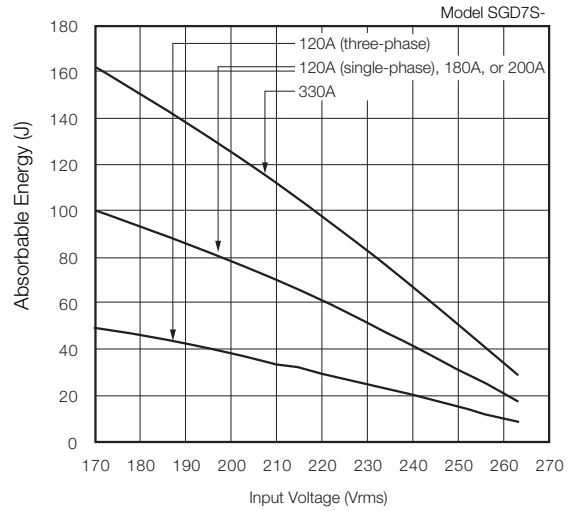
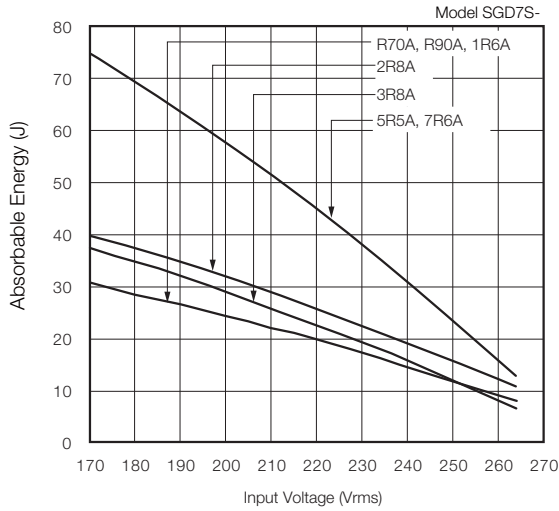

■ **Σ-7W SERVOPACKs**

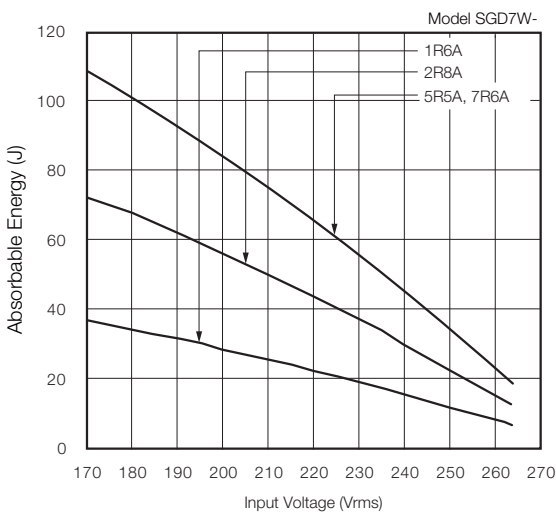

■ **Σ-7C SERVOPACKs**

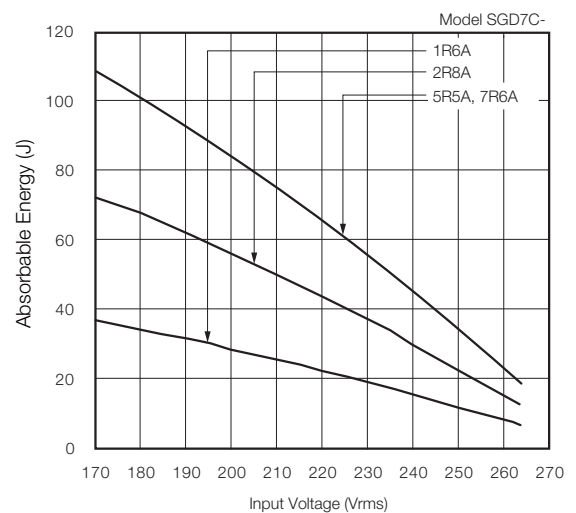

◆ Servomotor Winding Resistance Loss

The following figures show the relationship for each Servomotor between the Servomotor’s generated torque and the winding resistance loss.

■ SGM7M Rotary Servomotors

Contact your Yaskawa representative for information on SGM7M Servomotors.

■ SGM7J Rotary Servomotors

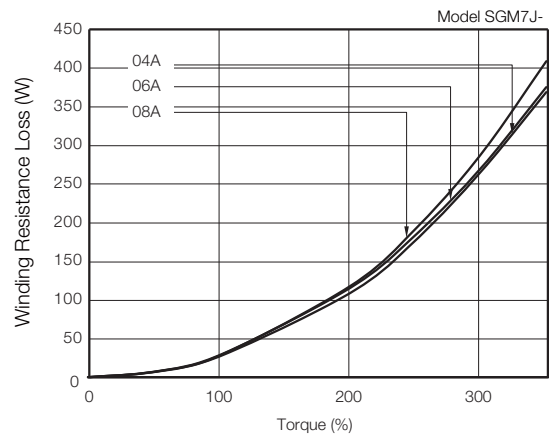
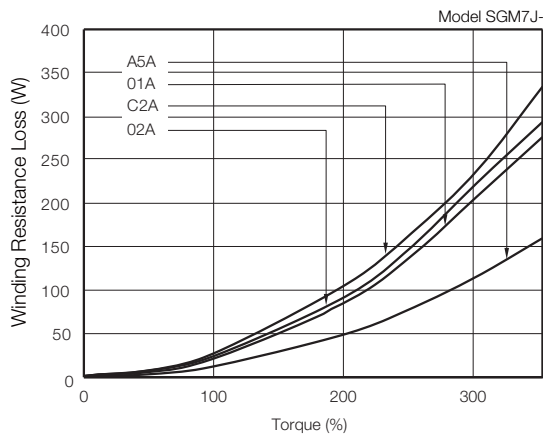

■ SGM7A Rotary Servomotors

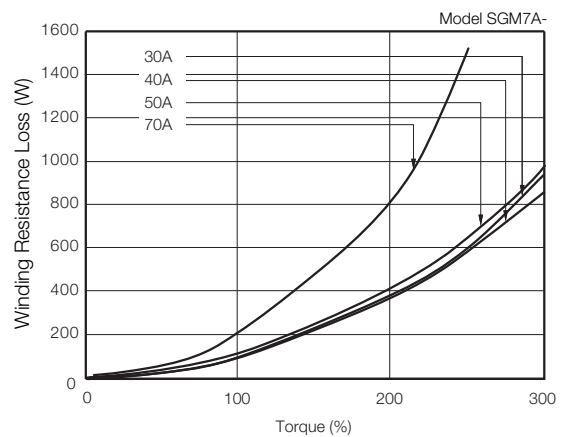
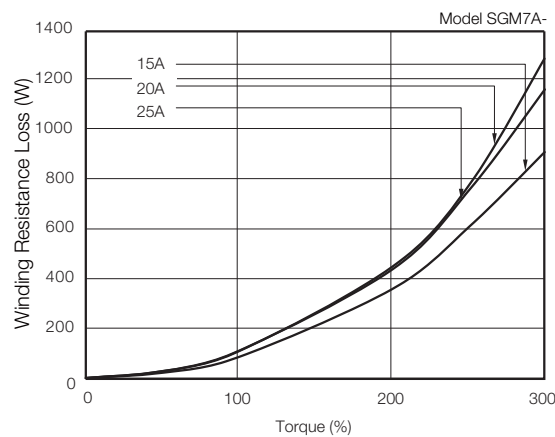
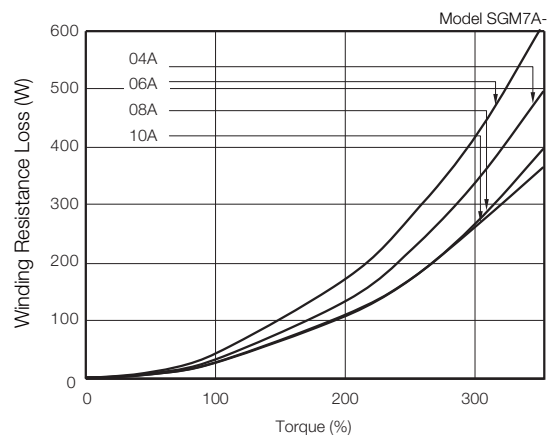
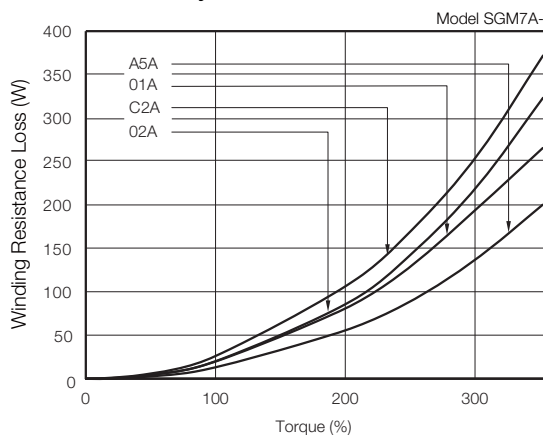

■ SGM7P Rotary Servomotors

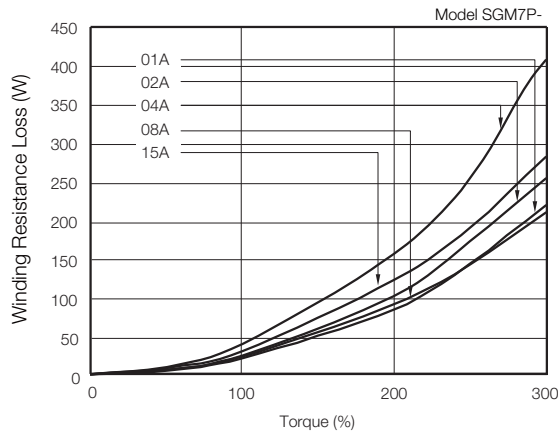

■ SGM7G Rotary Servomotors

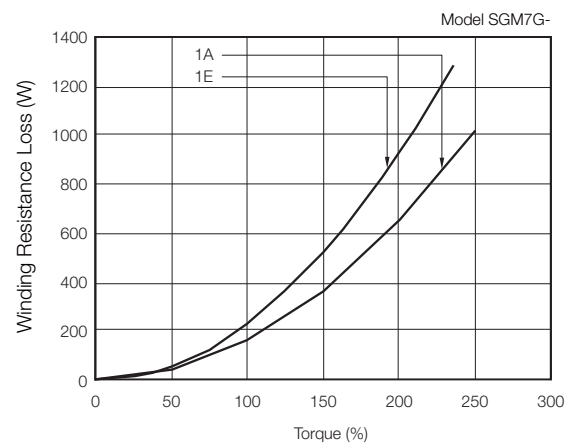
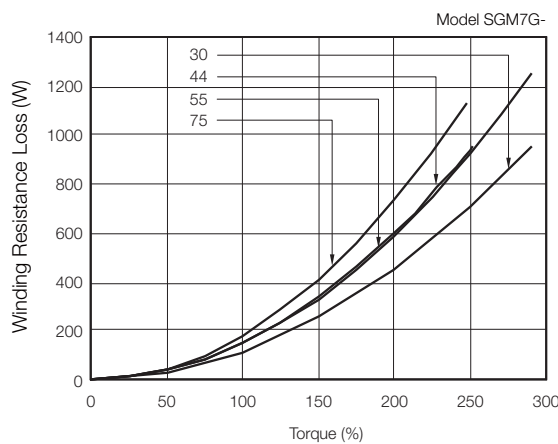
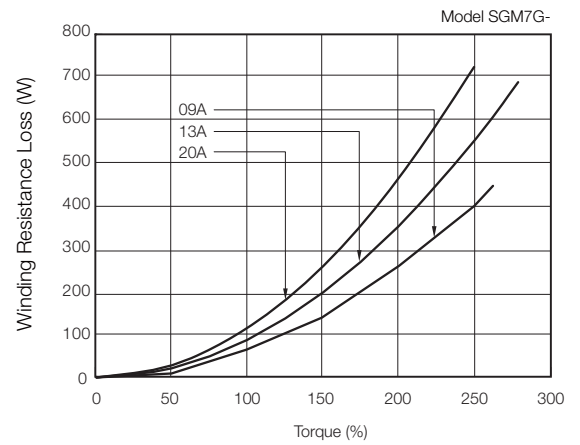
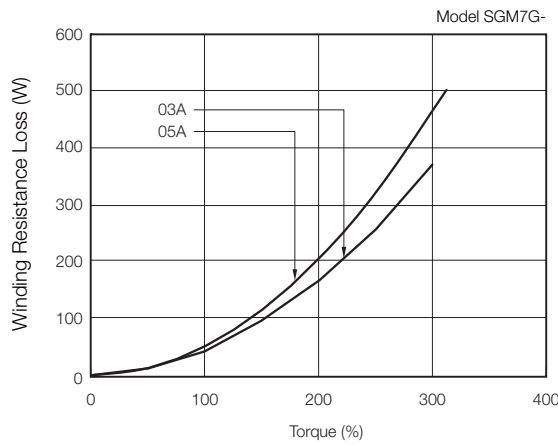

■ SGMMV Rotary Servomotors

Contact your Yaskawa representative for information on SGMMV Servomotors.

12.8 Regenerative Resistor

12.8.6 Selecting External Regenerative Resistor

■ SGM7D Direct Drive Servomotors

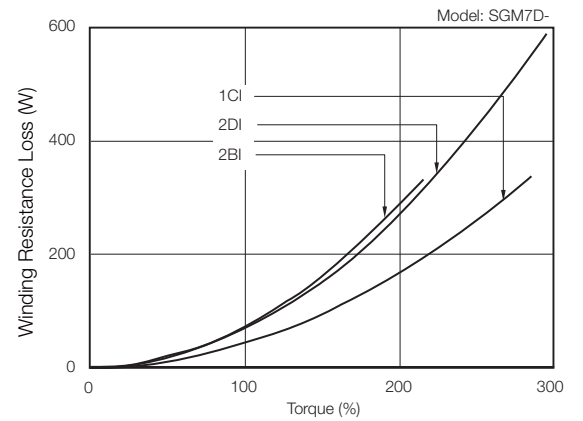
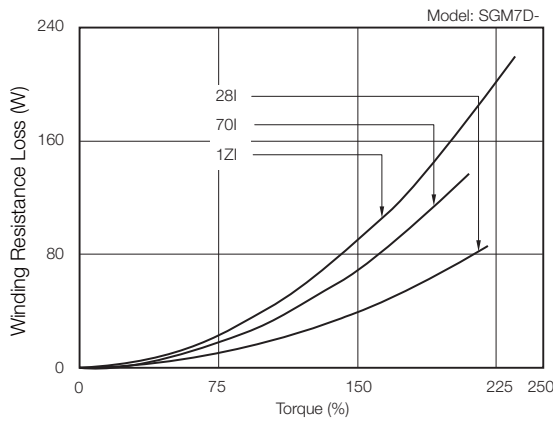
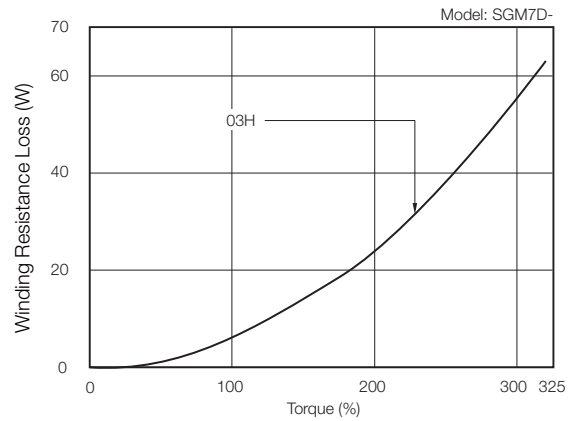
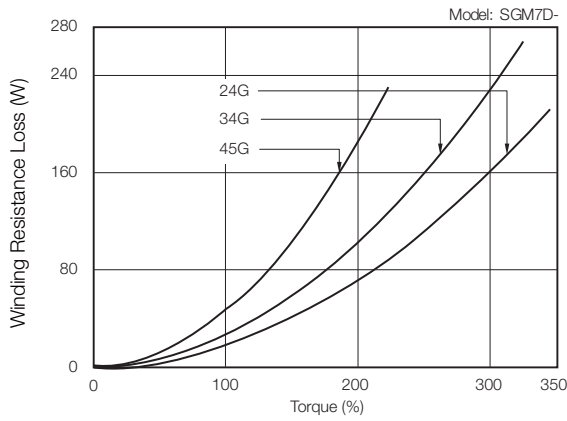
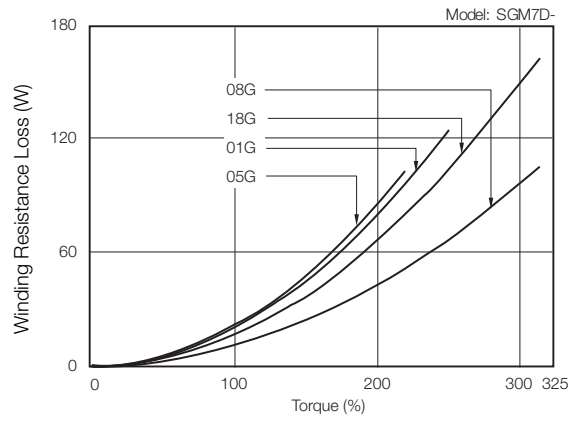
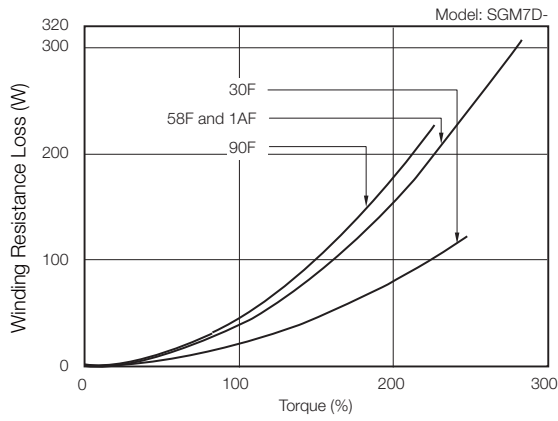

12.8.6 Selecting External Regenerative Resistor

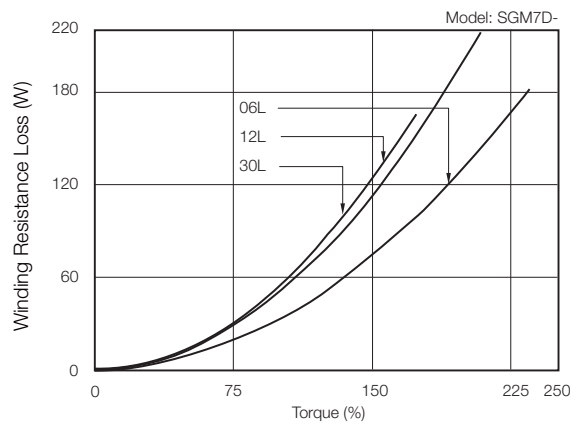
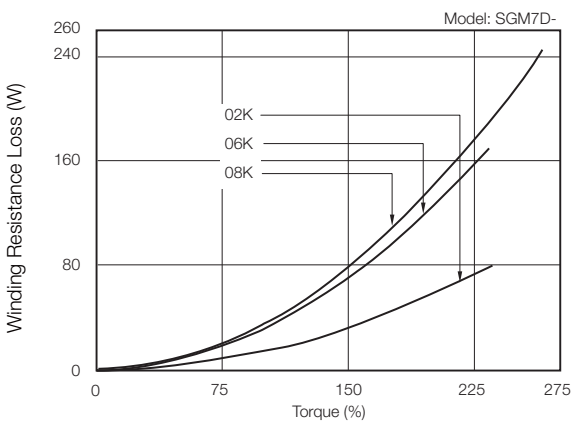
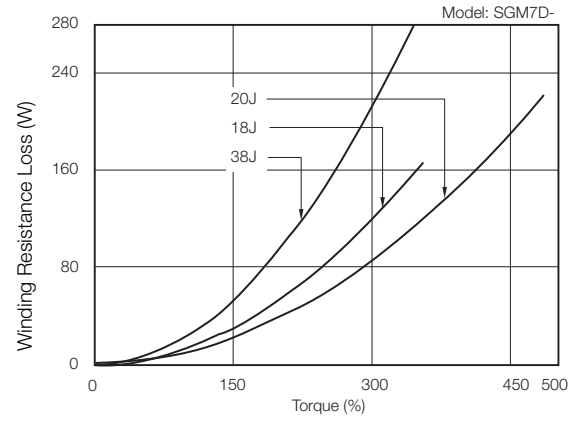
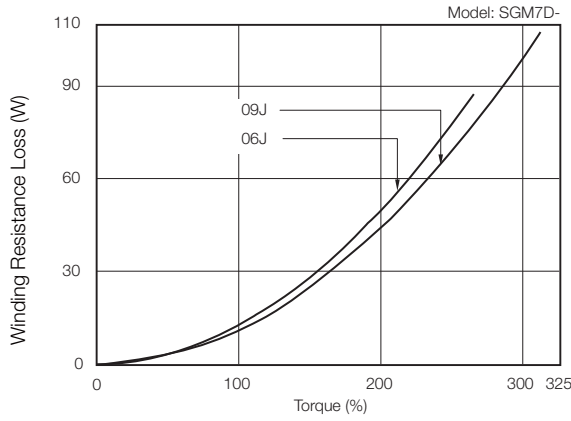

■ SGM7E Direct Drive Servomotors

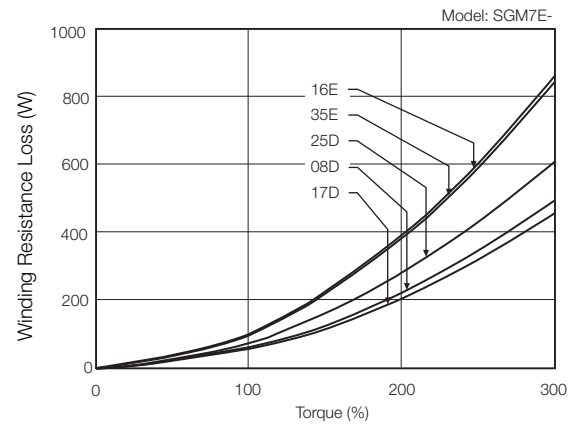
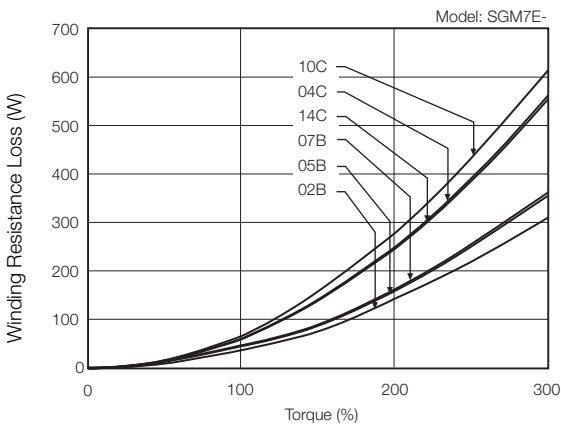

■ SGM7F Direct Drive Servomotors

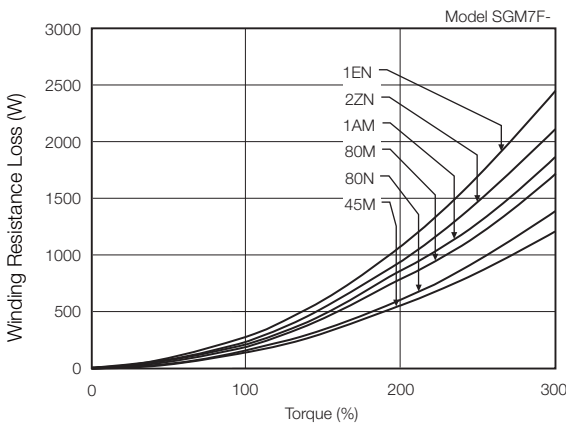
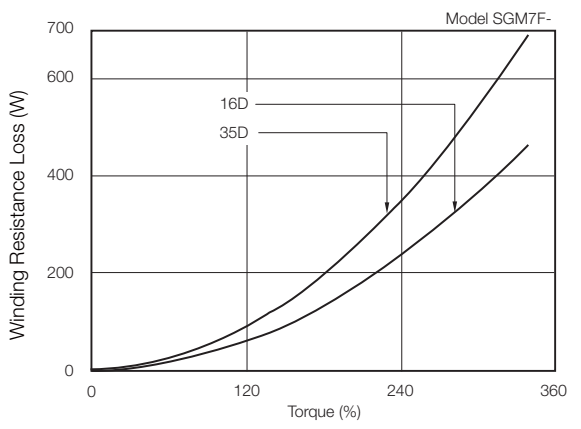
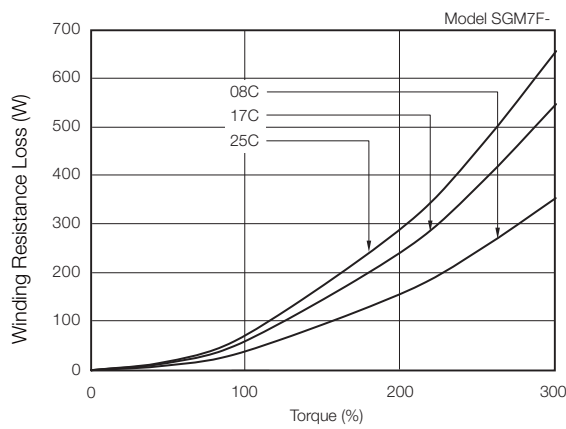
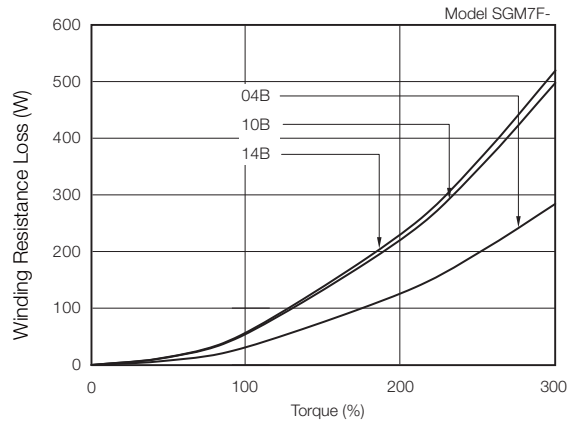
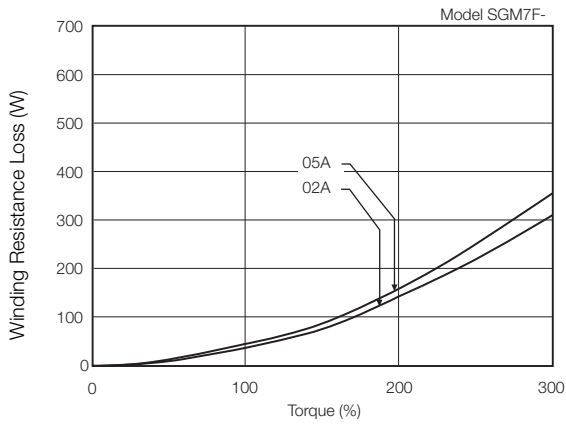

Note: Contact your Yaskawa representative for information on SGM7F-□□□ Servomotors.

■ SGMCV Direct Drive Servomotors

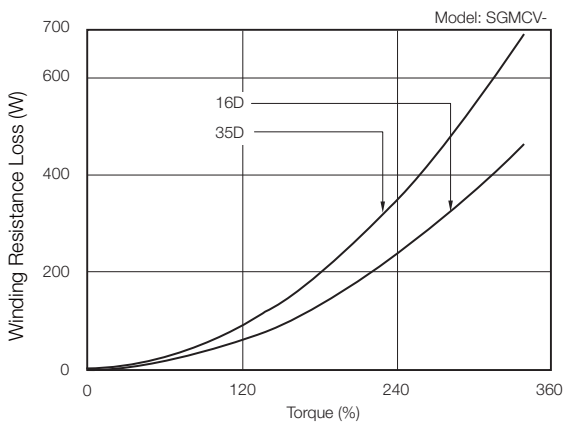
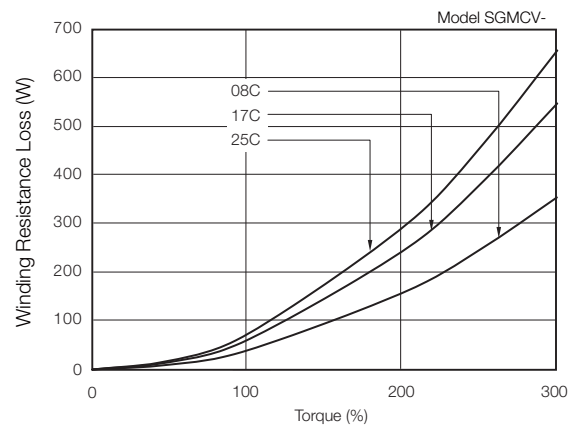
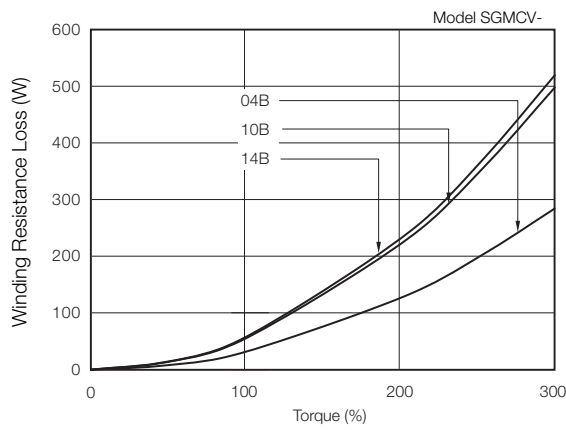

■ SGMCS Direct Drive Servomotors

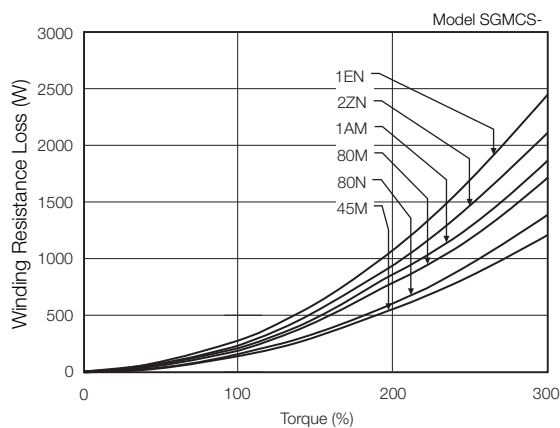
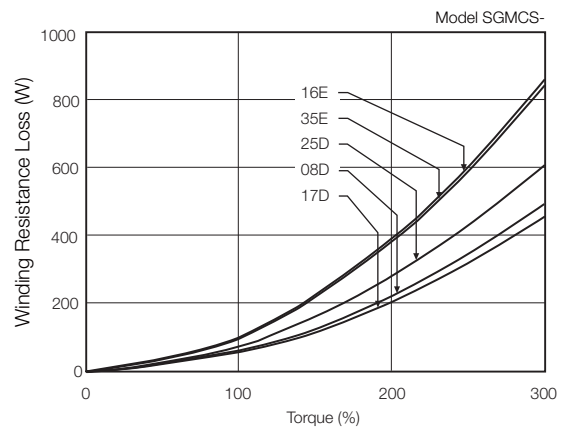
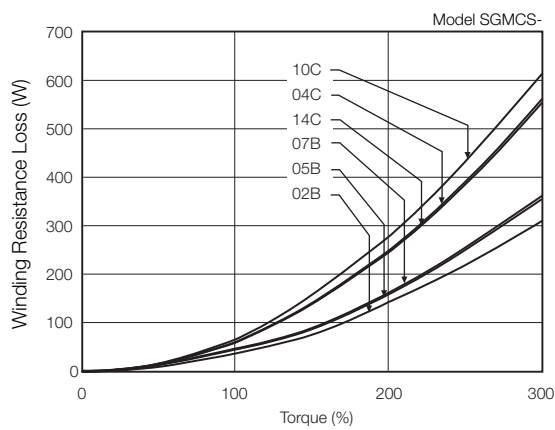

■ SGLGW Linear Servomotors

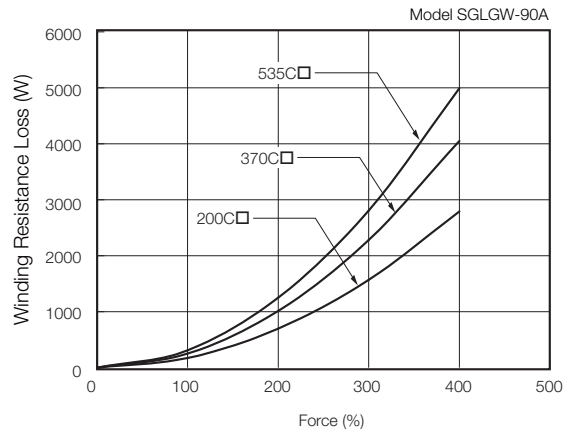
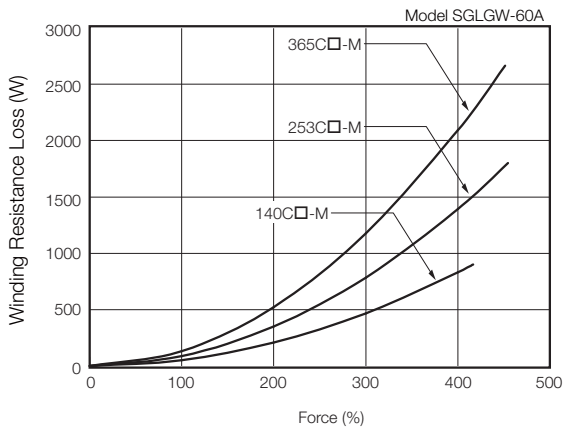
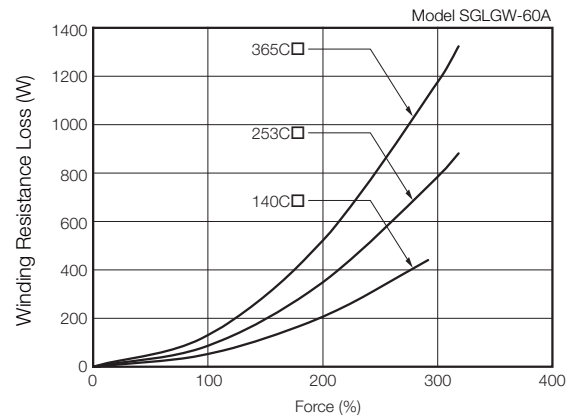
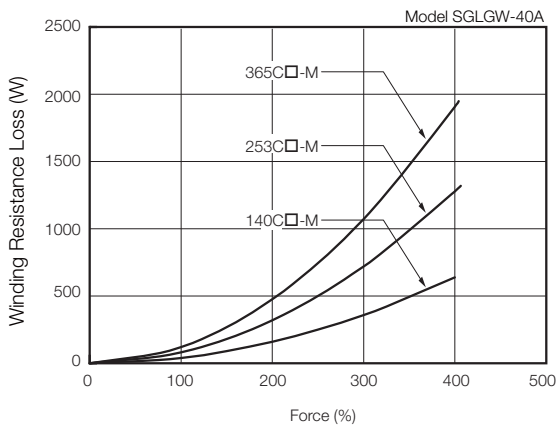
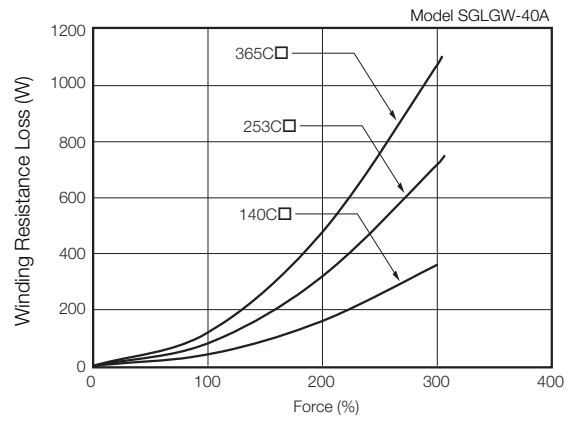
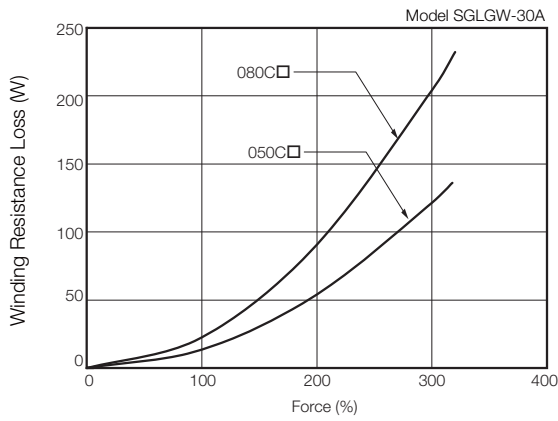

■ SGLFW2 Linear Servomotors

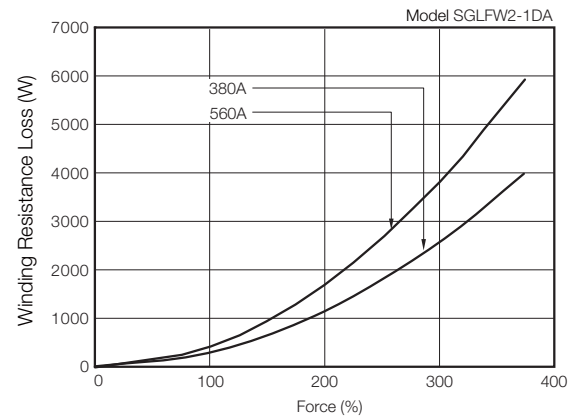
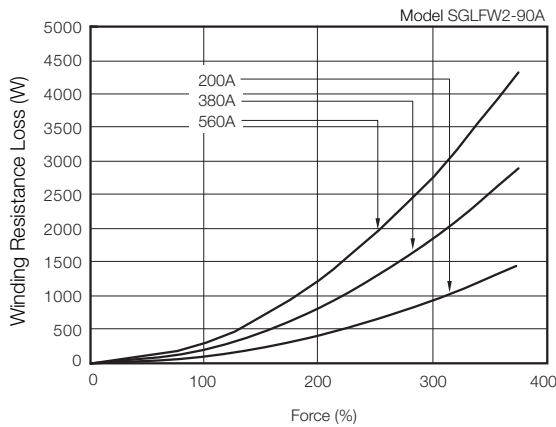
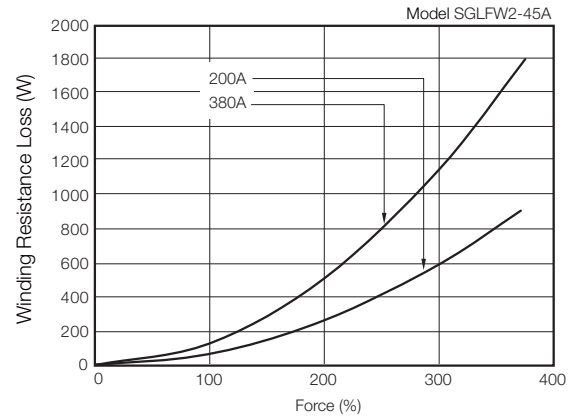
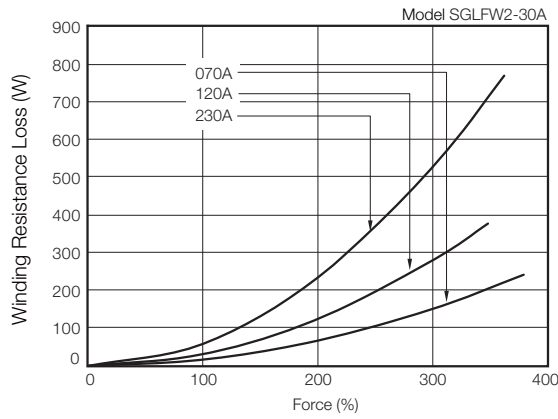

■ SGLFW Linear Servomotors

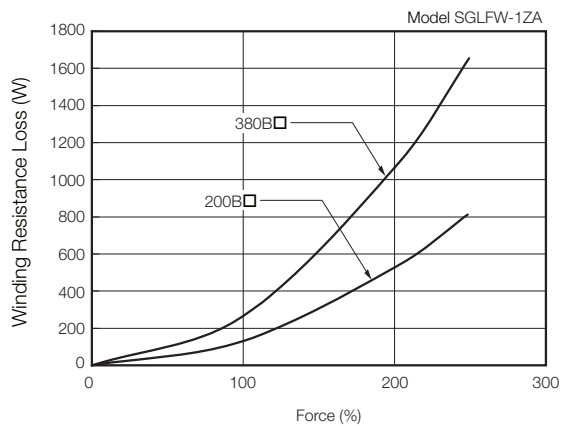
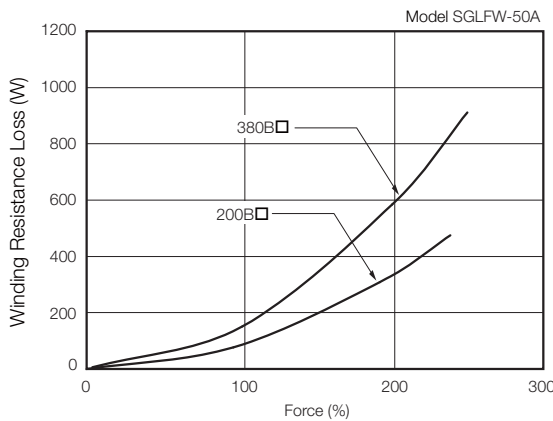
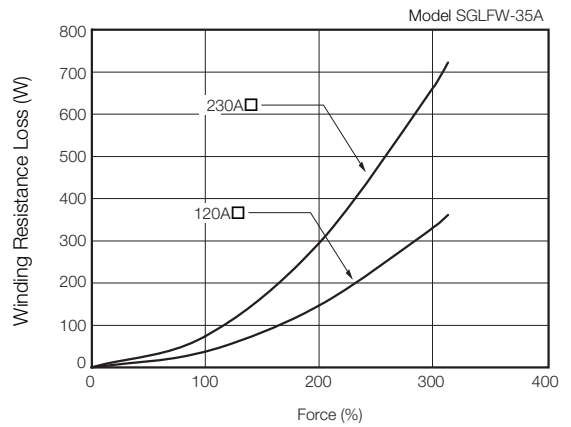
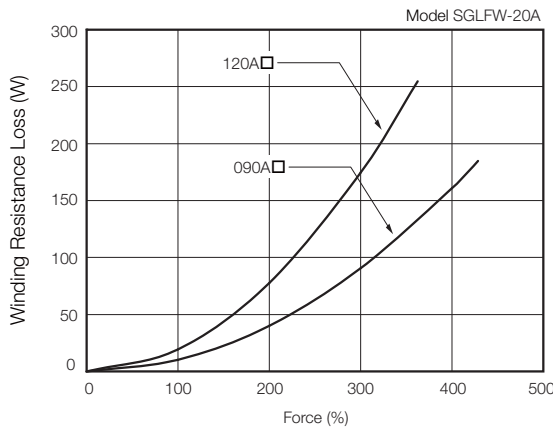

■ SGLTW Linear Servomotors

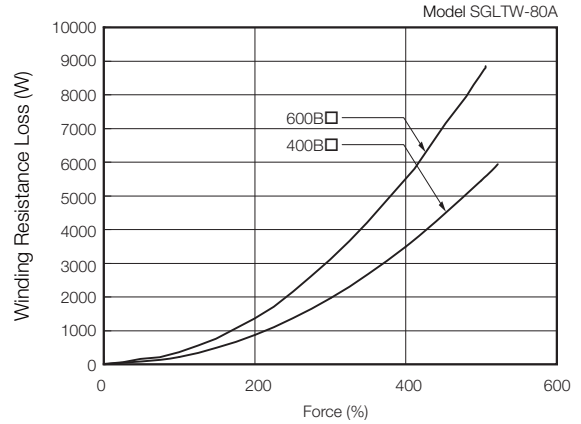
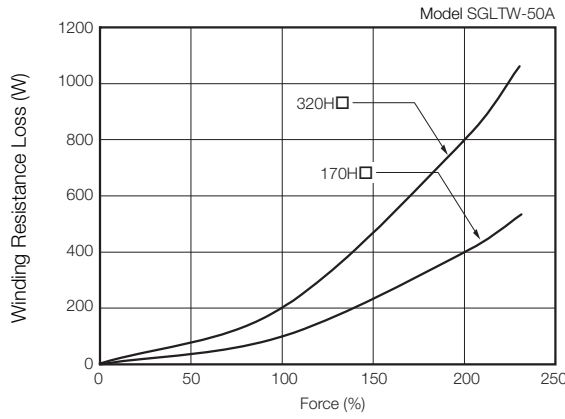
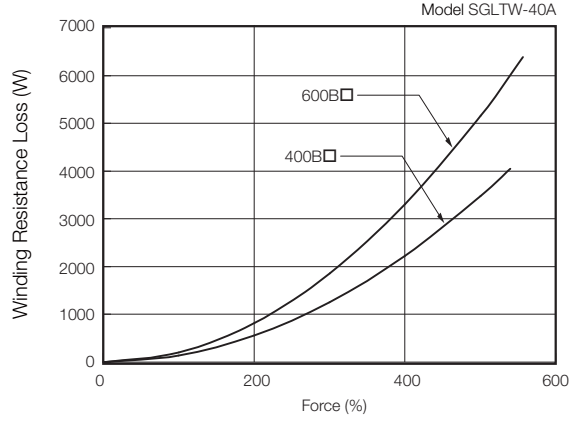
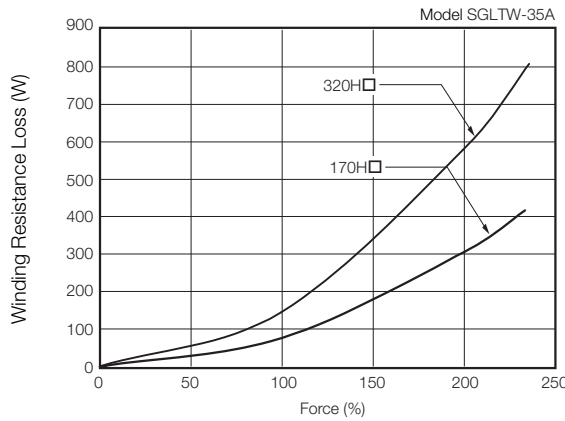
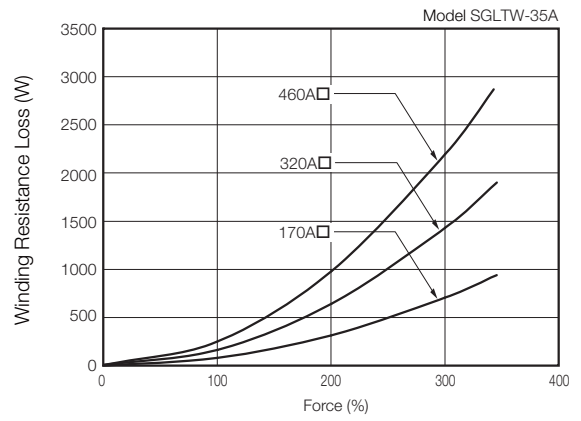
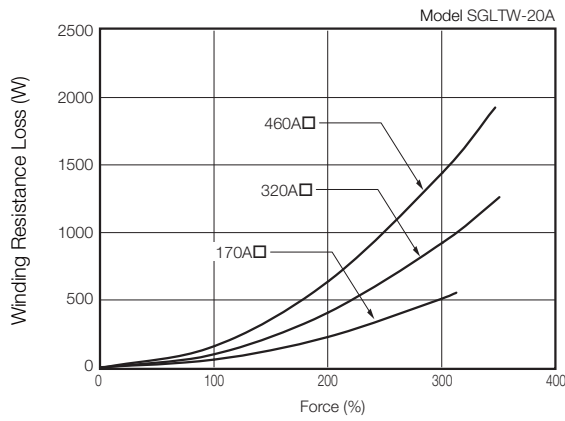

12.9 Inrush Current Suppression Devices

Inrush current suppression devices prevent equipment from being damaged by inrush current. They are used only when using a SERVOPACK of 5 kW or higher (SGD7S-330A, -470A, -550A, -590A, or -780A) with a DC power supply input.

Selection Table

◆ External Inrush Current Suppression Resistors

Main Circuit Power Supply	SERVOPACK Model: SGD7S-	External Inrush Current Suppression Resistor			Manufacturer
		Order Number	Resistance [Ω]	Rated Power [W]	
270 VDC	330A	RH120-5 Ω J	5	70	Iwaki Musen Kenkyusho Co., Ltd.
	470A				
	550A				
	590A	RH120-3 Ω J	3		
	780A				

◆ Inrush Current Suppression Resistor Short Relays

Main Circuit Power Supply	SERVOPACK Model: SGD7S-	Main Circuit DC Current [Arms]	Contact Specification	Recommended Inrush Current Suppression Resistor Short Relay			Manufacturer
				Model	Voltage Rating [Vdc]	Current Rating [A]	
270 VDC	330A	34	NO	G9EA-1-B	400	60	OMRON Corporation
	470A	36		G9EA-1-B-CA		100	
	550A	48		G9EA-1-B-CA* ¹		200	
	590A	68		G9EC-1-B* ²			
	780A	92					

*1. Connect two Relays in parallel. Also, maintain the same resistance between the DC power supply and SERVOPACK for the wiring for each Relay.

*2. This Relay is applicable only when the temperature of the Relay installation environment is 50°C or less.

Software

13

13.1 SigmaWin+: AC Servo Drive Engineering Tool . . 13-2

13.2 MPE720: System Integrated Engineering Tool . . 13-3

13.1 SigmaWin+: AC Servo Drive Engineering Tool

The SigmaWin+ Engineering Tool is used to set up and optimally tune Yaskawa Σ -series Servo Drives.

Features

- Sets parameters with a wizard.
- Displays SERVOPACK data on a computer just like on an oscilloscope.
- Estimates moments of inertia and measure vibration frequencies.
- Displays alarms and provides alarm diagnostics.

Setting Parameters with a Wizard

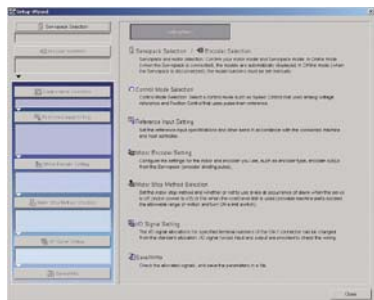

Displaying SERVOPACK Data on a Computer Just Like on an Oscilloscope.

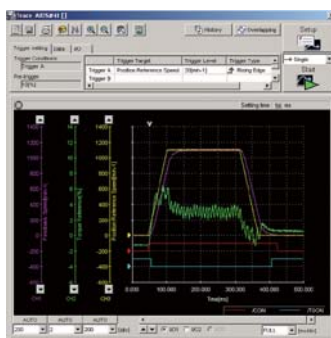

Estimating Moments of Inertia and Measuring Vibration Frequencies

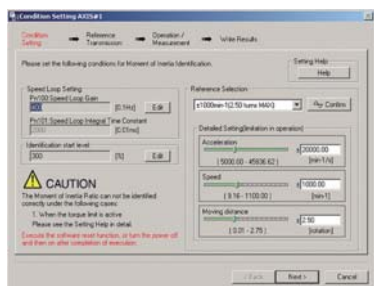

Displaying Alarms and Alarm Diagnostics

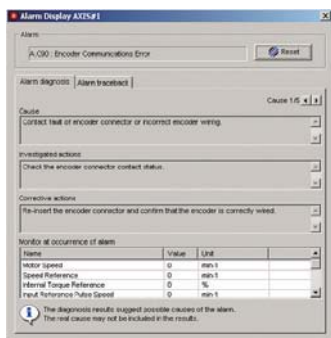

System Requirements

Item	System Requirement	
	Ver.5	Ver.7
Supported Languages	English and Japanese	Japanese, English, and Chinese (simplified)
OS	Windows XP, Windows Vista, or Windows 7 (32-bit or 64-bit edition)	Windows 10, Windows 8.1, Windows 8, or Windows 7 (32-bit or 64-bit edition)
Software Environment	–	Microsoft .NET Framework 4.5, .NET Framework 4.6
CPU	Pentium 200 MHz min.	1 GHz min. (recommended)
Memory	64 MB min. (96 MB or greater recommended)	1 GB min. (recommended)
Available Hard Disk Space	For Standard Setup: 350 MB min. (400 MB or greater recommended for installation)	500 MB min.
Browser used to display Help	–	Internet Explorer 9 or higher

13.2 MPE720: System Integrated Engineering Tool

MPE720 version 7 is a system integrated Engineering Tool that provides the complete development functionality to set up, adjust, program, maintain, and inspect not only Controller programs but also all of the devices necessary to design machine installations, including Servo Drives, AC Drives, and Distributed I/O Devices.

It is installed in a PC and operated on a PC interface through a connection between the PC and Machine Controller.

Features

◆ Complete Adjustment and Maintenance of Equipment Drive Devices

MPE720 version 7 connected to a Σ -7C SERVOPACK or MP-Series Machine Controller can be used to set up, adjust, and maintain AC Servo Drives, AC Drives, and I/O Devices connected to a network. There is no need to change connections, which increases efficiency.

◆ Greater Efficiency with the Best Programming Method

Ladder Programming

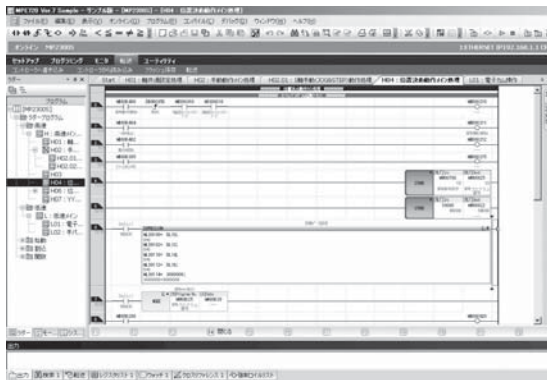

Motion Programming

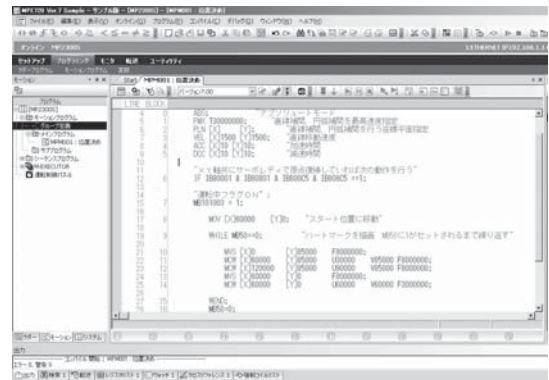

- The new user interface lets just about anyone easily use the MPE720.
- An improved EXPRESSION instruction simplifies programming calculation in ladder diagrams.
- Support is provided for all types of control, including position, speed, torque, and phase control.
- Positioning and interpolation can be programmed with one instruction.
- Programs can be very easily edited using expressions in a text format.
- New variable programming can provide PC-like programming.

System Requirements

Item	Specification
CPU	1 GHz or more recommended (manufactured by Intel or other companies)
Memory Capacity	1 GB or more recommended*
Available Hard Disk Space	700 MB or more (includes standard workspace memory after installation of MPE720)
Display Resolution	1,280 × 800 pixels or more recommended
CD Drive	1 (only for installation)
Communications Ports	RS-232C, Ethernet, MP2100 bus, and USB
OS	Windows 10, Windows 8, Windows 8.1, or Windows 7 (32-bit or 64-bit)
.NET Environment	.NET Framework 4.5
Supported Languages	English and Japanese

* Expand memory if other application programs are run simultaneously with MPE720 on the same computer. Performance may be slow due to the use of memory by multiple application programs that are run simultaneously.

Other Peripheral Devices and Options

14

14.1 Surge Absorbers (Varistors) and Diodes for Holding Brake Power Supplies .. 14-2

14.2 Batteries for Servomotors with Absolute Encoders .. 14-4

14.2.1 Using Encoder Cables with Battery Cases 14-4

14.2.2 When Installing a Battery on the Host Controller . . 14-5

14.3 Precautions for Connecting a Σ -V-Series Cable to a Σ -7-Series Servomotor .. 14-6

14.3.1 Restrictions in Using Σ -V-Series Cables 14-6

14.3.2 Precautions When the Encoder Cable Is Installed toward the Load Side 14-6

14.3.3 Cables That Connect to Σ -7-Series Servomotors 14-7

14.4 Optional Metal Connectors for Servomotor Main Circuit Cables .. 14-8

14.4.1 SGM7J and SGM7A (50 W to 150 W) 14-8

14.4.2 SGM7J and SGM7A (200 W to 600 W) 14-8

14.4.3 SGM7J and SGM7A (750 W and 1.0 kW) 14-9

14.1 Surge Absorbers (Varistors) and Diodes for Holding Brake Power Supplies

Surge Absorbers (varistors) and Diodes for holding brake power supplies help prevent damage to brake coils caused by voltage surges.

If you use a Servomotor with a Holding Brake and switch the brake power supply circuit on the DC side, connect a Surge Absorber (varistor) or Diode that is suitable for the brake power supply voltage and current.



Note

- When you select a Surge Absorber, varistor, or Diode for your application, consider the service life and test all operations, including the brake timing, before you use the Servomotor.
- If you connect an SSR (i.e., a semiconductor relay) to switch the brake circuit, use a Diode.
- If you connect a Diode, more time is required to brake than with a Surge Absorber. (Refer to the following figure.) If you use a diode, consider this in the application.

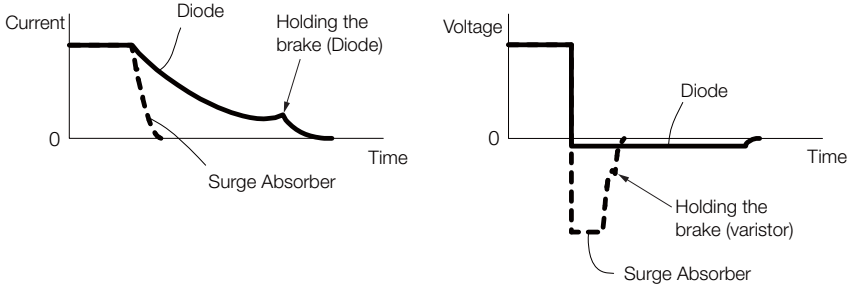

Surge Absorbers (Varistors) for Holding Brake Power Supplies

Use the following table as reference in selecting a Surge Absorber. Elements were selected for a Surge Absorber surrounding air temperature range of -20°C to 60°C and an ON/OFF switching frequency of 10 times or less per minute. The information in this table is for reference only, and does not ensure operation in combination with the holding brake.

Holding Brake Power Supply Voltage		24 VDC	
Manufacturer		Nippon Chemi-Con Corporation	Semitec Corporation
		Order Number	
Brake Rated Current	1 A max.	TND05V-121KB00AAA0	Z5D121
	2 A max.	TND07V-121KB00AAA0	Z7D121
	4 A max.	TND10V-121KB00AAA0	Z10D121
	8 A max.	TND14V-121KB00AAA0	Z15D121

Diodes for Holding Brake Power Supplies

Select a Diode for the holding brake power supply with a rated current that is greater than that of the holding brake and with the recommended withstand voltage given in the following table.

Diodes are not provided by Yaskawa.

Holding Brake Power Supply Unit Specifications		Withstand Voltage
Rated Output Voltage	Input Voltage	
24 VDC	200 V	100 V to 200 V

Circuit Diagrams

◆ Circuit for a Surge Absorber (Varistor)

A Surge Absorber (varistor) has no polarity.

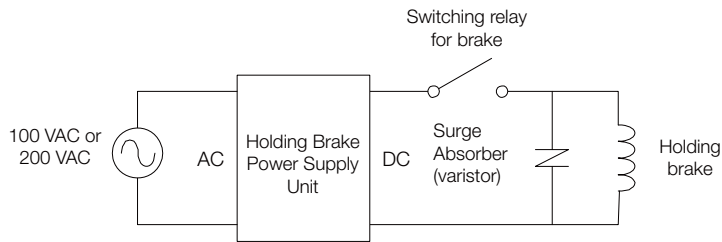

◆ Circuit for a Diode

A Diode has polarity. Refer to the following figure for connections.

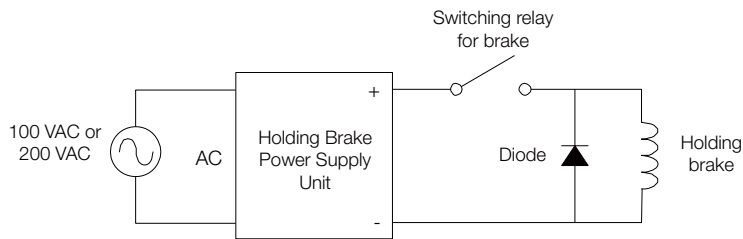

Holding Brake Power Supply Units are not provided by Yaskawa.

Note

14.2 Batteries for Servomotors with Absolute Encoders

If you use an absolute encoder, you can use an Encoder Cable with a Battery Case connected to it to supply power and retain the absolute position data.

You can also retain the absolute position data by supplying power from a battery on the host controller.

Note: A Battery Case is not required if you use a Servomotor with a Batteryless Absolute Encoder.

NOTICE

- **Install a battery at either the host controller or on the Encoder Cable.**
If you install batteries both at the host controller and on the Encoder Cable at the same time, you will create a loop circuit between the batteries, resulting in a risk of damage or burning.
- **When connecting a battery, connect the polarity correctly.**
There is a risk of battery rupture or encoder failure.

14.2.1 Using Encoder Cables with Battery Cases

A Battery Case is attached to an Encoder Cable with a Battery Case. To replace the battery, obtain a Lithium Battery (JZSP-BA01) and mount it in the Battery Case.



1. You cannot attach the Battery Case to Encoder Cables for Incremental Encoders or Batteryless Absolute Encoders.
2. Install the Battery Case where the surrounding air temperature is between -5°C and 60°C.

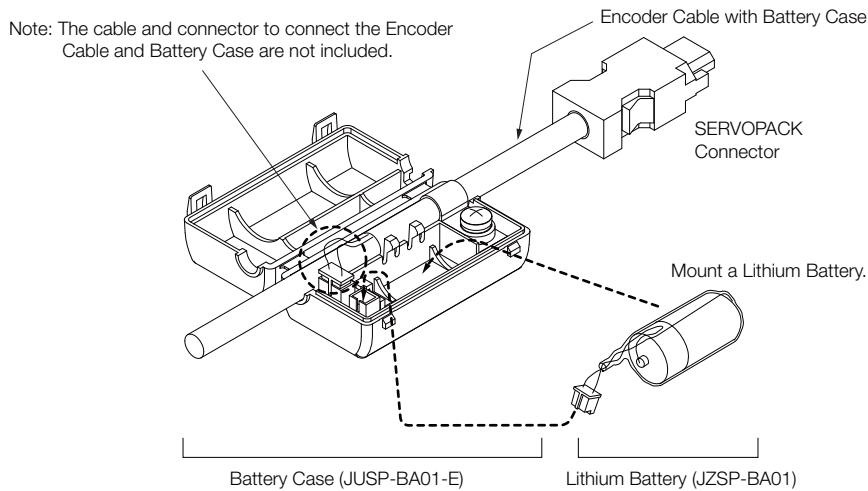

◆ Selection Table

Name	Order Number	Remarks
Battery Case (case only)	JZSP-BA01-E	The Encoder Cable and Battery are not included. (This is a replacement part for a damaged Battery Case.)
Lithium Battery	JZSP-BA01	This is a special battery that is mounted into the Battery Case.

◆ Lithium Battery Dimensional Drawing

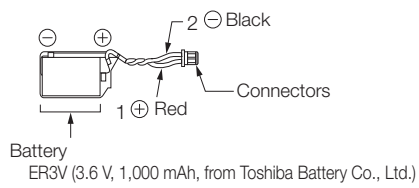

14.2.2 When Installing a Battery on the Host Controller

Use a battery that meets the specifications of the host controller.

Use the recommended Battery given in the following table or the equivalent.

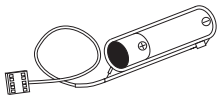

◆ Selection Table

Order Number	Specification	Manufacturer
ER6VC3N	3.6 V, 2,000 mAh	Toshiba Battery Co., Ltd.

14.3 Precautions for Connecting a Σ -V-Series Cable to a Σ -7-Series Servomotor

If you already have Σ -V-Series Servomotor Main Circuit Cables or Encoder Cables, you can use them with SGM7J or SGM7A-A5 to SGM7A-10 Servomotors. Before you do, read this section for information on cable connection conditions and the shapes of the cables that can be connected.

14.3.1 Restrictions in Using Σ -V-Series Cables

The protective structure will be IP65 if you connect Σ -V-Series Cables (Servomotor Main Circuit Cables or Encoder Cables) to Σ -7-Series Servomotors.

The connector lock screws on the Servomotor Main Circuit Cable that is enclosed with the Servomotor will be exposed, but the protective structure will be maintained.

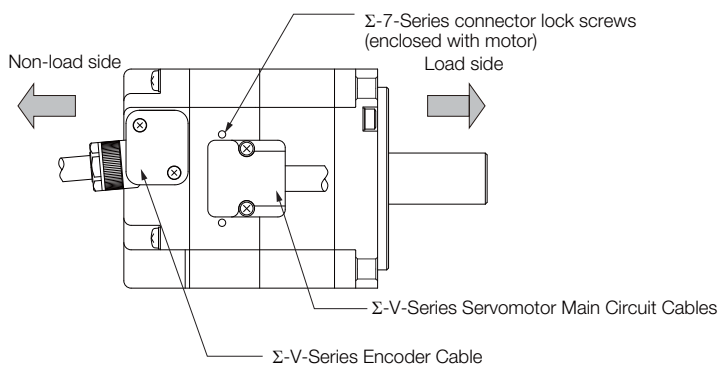

14.3.2 Precautions When the Encoder Cable Is Installed toward the Load Side

You cannot install a Σ -V-Series Encoder Cable toward the load side.

If you need to install the Cables as shown in the following figure, use a Σ -7-Series JZSPC7P□□D-□□-E Encoder Cable (cable installed toward the load).

Note: Refer to the following section for information on Encoder Cables for SGM7J Servomotors.

3.4 Encoder Cables of 20 m or Less on page 3-10

Refer to the following section for information on Encoder Cables for SGM7A Servomotors.

4.5 Encoder Cables of 20 m or Less on page 4-24

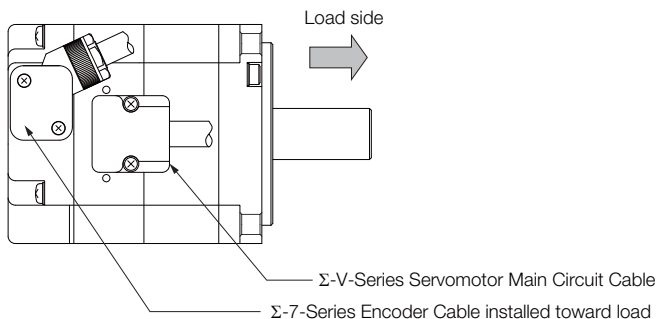

14.3.3 Cables That Connect to Σ -7-Series Servomotors

The following tables list the Cables that you can connect to Σ -7-Series SGM7J and SGM7A Servomotors.

Servomotor Main Circuit Cables

Name	Servomotor Model	Order Number*		Appearance
		Standard Cable	Flexible Cable	
For Servomotors without Holding Brakes	SGM7J-A5 to -C2 SGM7A-A5 to -C2 50 W to 150 W	JZSP-CSM01- □□-E	JZSP-CSM21- □□-E	
	SGM7J-02 to -06 SGM7A-02 to -06 200 W to 600 W	JZSP-CSM02- □□-E	JZSP-CSM22- □□-E	
	SGM7J-08 750 W SGM7A-08 or -10 750 W or 1.0 kW	JZSP-CSM03- □□-E	JZSP-CSM23- □□-E	
For Servomotors with Holding Brakes	SGM7J-A5 to -C2 SGM7A-A5 to -C2 50 W to 150 W	JZSP-CSM11- □□-E	JZSP-CSM31- □□-E	
	SGM7J-02 to -06 SGM7A-02 to -06 200 W to 600 W	JZSP-CSM12- □□-E	JZSP-CSM32- □□-E	
	SGM7J-08 750 W SGM7A-08 or -10 750 W or 1.0 kW	JZSP-CSM13- □□-E	JZSP-CSM33- □□-E	

* Replace the boxes (□□) in the order number with the cable length (03, 05, 10, 15, 20, 30, 40, or 50).

Encoder Cables

Name	Servomotor Model	Order Number*		Appearance
		Standard Cable	Flexible Cable	
Encoder Cables for Incremental Encoders or Batteryless Absolute Encoders	SGM7J (all models) SGM7A (SGM7A-A5 to -10)	JZSP-CSP01- □□-E	JZSP-CSP21- □□-E	
Encoder Cables for Absolute Encoders		JZSP-CSP05- □□-E	JZSP-CSP25- □□-E	

* Replace the boxes (□□) in the order number with the cable length (03, 05, 10, 15, or 20).

14.4 Optional Metal Connectors for Servomotor Main Circuit Cables

Servomotor Main Circuit Connectors with aluminum housings are available as options. You can use them for SGM7J and SGM7A Servomotors. If you use shielded cables with main circuit connectors that have aluminum housings, you can shield the cable and connector housing.

Note: 1. The connectors have an IP65 protective structure.

2. The cable installation direction is toward the load. Metal connectors are not available for connecting the cable toward the non-load side.

14.4.1 SGM7J and SGM7A (50 W to 150 W)

Item		Description	External Dimensions [mm]
Applicable Servomotors		SGM7J-A5A, -01A, or -C2A SGM7A-A5A, -01A, or -C2A	
Manufacturer		J.S.T. Mfg. Co., Ltd.	
Order Number	Receptacle	J17M-06FMH-7KL-M	
	Contacts	SJ1F-01GF-P0.8	
Applicable Wire Sizes		Power terminals: AWG20 Holding brake terminals: AWG20 to AWG24	
Outer Diameter of Insulating Sheath		1.11 mm to 1.53 mm	
Mounting Screws		M2 pan-head screws	
Applicable Cable Diameter		7 mm ±0.3 mm	
User Instructions		JFA Connector J-1700M	
Crimping Tool*	Hand Tool	YRS-8841	
	Applicator	APLMK SJ1F/M01-08	

* A Crimping Tool is required. Contact the connector manufacturer for details.

Note: Cables are not included. Purchase them separately.

14.4.2 SGM7J and SGM7A (200 W to 600 W)

Item		Description	External Dimensions [mm]
Applicable Servomotors		SGM7J-02A, -04A, or -06A SGM7A-02A, -04A, or -06A	
Manufacturer		J.S.T. Mfg. Co., Ltd.	
Order Number	Receptacle	J27M-06FMH-7KL-M	
	Contacts	SJ2F-01GF-P1.0	
Applicable Wire Sizes		Power terminals: AWG20 Holding brake terminals: AWG20 to AWG24	
Outer Diameter of Insulating Sheath		1.11 mm to 1.53 mm	
Mounting Screws		M2 pan-head screws	
Applicable Cable Diameter		7 mm ±0.3 mm	
User Instructions		JFA Connector J-2700M	
Crimping Tool*	Hand Tool	YRS-8861	
	Applicator	APLMK SJ2F/M01-10	

* A Crimping Tool is required. Contact the connector manufacturer for details.

Note: Cables are not included. Purchase them separately.

14.4.3 SGM7J and SGM7A (750 W and 1.0 kW)

Item		Description		External Dimensions [mm]
Applicable Servomotors		SGM7J-08A SGM7A-08A or -10A		
Manufacturer		J.S.T. Mfg. Co., Ltd.		
Order Number	Receptacle	J37M-06FMH-8KL-ML		
	Contacts	Power terminals: SJ3F-41GF-P1.8	Holding brake terminals: SJ3F-01GF-P1.8	
Applicable Wire Sizes		AWG16	AWG20 to AWG24	
Outer Diameter of Insulating Sheath		1.53 mm to 2.5 mm	1.11 mm to 1.86 mm	
Mounting Screws		M2.5 pan-head screws		
Applicable Cable Diameter		8 mm ±0.3 mm		
User Instructions		JFA Connector J-3700M		
Crimping Tool*	Hand Tool	Power terminals: YRF-880 Holding brake terminals: YRF-881		
	Applicator	Power terminals: APLMK SJ3F/M41-20 Holding brake terminals: APLMK SJ3F/M01-20		

* A Crimping Tool is required. Contact the connector manufacturer for details.

Note: Cables are not included. Purchase them separately.

Revision History

The date of publication, revision number, and web revision number are given at the bottom right of the back cover. Refer to the following example.

MANUAL NO. SIEP S800001 32B <1>-1
 Published in Japan August 2014

┌─── Web revision number
 └─── Revision number
 └─── Date of publication

Date of Publication	Rev. No.	Web Rev. No.	Section	Revised Contents
April 2026	<17>	0	All chapters	Partly revised.
			Back cover	Revision: Address
August 2024	<16>	0	All chapters	Partly revised.
April 2024	<15>	0	9.1.1, 11.2	Partly revised.
September 2023	<14>	0	8.3.2	Partly revised.
			Back cover	Revision: Address
February 2023	<13>	0	10.5.2, 10.5.3, 10.5.4, 10.11.3, 11.1.1, 11.2.1, 11.2.2	Partly revised.
September 2022	<12>	0	9.1.2, 9.2.6, 11.1.1	Addition: Information on Linear Encoder (AT13□□A-Series) from Mitutoyo Corporation
			9.1.2, 9.2.3, 11.1.1	Addition: Information on Linear Encoder (FORTiS-Series) from Renishaw PLC
			11.1.1	Addition: Information on Linear Encoder (PH03-□□L00) from Canon Precision Inc.
September 2021	<11>	0	All chapters	Partly revised.
April 2021	<10>	2	All chapters	Partly revised.
February 2020		1	9.1, 9.2.7, 11.1.1	Addition: Information on Linear Encoder from Canon Precision Inc.
			9.1, 9.2.1, 11.1.1	Partly revised.
November 2019		0	All chapters	Partly revised.
January 2019	<9>	1	12.8.5	Addition: Approximate mass of Regenerative Resistor Units (JUSP-RA04-E and JUSP-RA05-E)
October 2018		0	Preface, Chapters 2 to 7	Partly revised.
			9.1.2, 9.2.5, 11.1.1	Addition: Absolute linear encoder from Fagor Automation S. Coop.
			10.5, 10.10.1	Revision: Signal names in the wiring specifications
			Back cover	Revision: Address
May 2018	<8>	1	Preface	Partly revised.
			All chapters	Revision: Heidenhain Corporation changed to Dr. JOHANNES HEIDENHAIN GmbH.
			6.2.1, 6.2.2	Revision: Information on wiring specifications for SGM7G-03, -05 (300 W, 450 W)
			6.3.1	Revision: Information on external dimensions of Servomotor connector kits
February 2018		0	All chapters	Addition: Information on SGM7M Rotary Servomotors
			3.3.1, 4.3.1, 14.4.1, 14.4.3	Revision: Hand Tool Model

Date of Publication	Rev. No.	Web Rev. No.	Section	Revised Contents
January 2018	<7>	1	All chapters	Partly revised.
August 2017		0	Preface	Partly revised.
			8.1.2, 8.2.3, 10.1.1	Addition: Information on SQ47 and SQ57 Linear Encoder from Magnescale Co., Ltd.
			8.1.2, 8.2.1, 10.1.1	Addition: Information on LIC2100-series and LC415 Linear Encoder from Dr. JOHANNES HEIDENHAIN GmbH
			8.1.2, 8.2.2, 10.1.1	Addition: Information on RESOLUTE-series Linear Encoder from Renishaw plc
			10.1.1	Addition: Basic specifications
				Addition: Pin arrangement of External Encoder Connector
				Addition: Information on ECA4412 and ROC□310 Rotary Encoder from Dr. JOHANNES HEIDENHAIN GmbH
Back cover	Addition: Information on RESOLUTE-series Rotary Encoder from Renishaw plc			
March 2017	<6>	0	Preface	Revision: Address
March 2017	<6>	0	Preface	Partly revised.
			All chapters	Addition: Information on SGM7E, SGM7F-02A to -07A, and SGM7F-45M to -Z2N Direct Drive Servomotors
			All chapters	Revision: Information on Relay Encoder Cables with a Battery Case
			Chapters 3 to 6 and 13	Addition: Information on batteryless absolute encoders
			5.3.1	Revision: Receptacle model number
			Chapter 7	Revision: Revision to order of contents
			7.4, 7.5	Deletion: Wire colors in connection specifications
			8.2.2	Addition: EVOLUTE-series Linear Encoders from Renishaw plc
			8.2.3, 10.1.1	Revision: Encoder Cable
			8.4.1	Addition: SGLFW2 with water-cooled specification
			10.1.1	Addition: Absolute Rotary Encoders from Dr. JOHANNES HEIDENHAIN GmbH (Models: RCN□□10)
			11.8.5	Addition: RH450
				Revision: RH450FY specifications
			12.1	Revision: System requirements
12.2	Addition: MPE720 System Integrated Engineering Tool			
Back cover	Revision: Address			
July 2016	<5>	0	Preface	Partly revised.
July 2016	<5>	0	All chapters	Addition: Information on Σ -7C SERVOPACKs
				Addition: Information on SGM7F Direct Drive Servomotors
				Deletion: Information on SGLC Linear Servomotors
December 2015	<4>	0	Preface	Addition: Information on SGMMV Servomotors
December 2015	<4>	0	Chapters 1 and 11	Addition: Information on SERVOPACKs with a single-phase, 100-VAC power supply input
			Chapter 2	Addition: Information on SGMMV Servomotors
			2.3.2, 3.4.2, 4.4.2, 4.5.3, 5.4.2, 6.4.2, 6.5.3, 7.4.1, 7.4.2, 7.5.1, 7.5.2	Revision: Battery Case pin numbers in connection specifications
			8.1, 8.2.1, 8.2.3, 10.1.1	Addition: Information on SmartSCALE Linear Encoder from Magnescale Co., Ltd. and LC115 Linear Encoder from Dr. JOHANNES HEIDENHAIN GmbH
			11.8.6	Addition: Information on allowable frequency for regenerative operation for SGMMV Servomotors
				Revision: Information on allowable frequency for regenerative operation for SGM7D Servomotors

Date of Publication	Rev. No.	Web Rev. No.	Section	Revised Contents
September 2015	<3>	0	Front cover	Revision: Format
			Preface	Partly revised.
			All chapters	Revision: Molex Japan Co., Ltd. changed to Molex Incorporated.
			Chapter 6	Addition: Descriptions of SGM7D and SGMCV-□□D Servomotors
			8.5.3	Revision: Description of wiring specifications
			11.2	Addition: System requirements for SigmaWin+ version 7
			Back cover	Revision: Address and format
March 2015	<2>	0	All chapters	Partly revised.
			Chapters 2, 3, 4, 5, and 6	Revision: Information on Relay Encoder Cables
			2.6, 3.6, 4.6, 5.6, 6.6, and chapter 8	Revision: Sumitomo 3M Ltd. changed to 3M Japan Limited.
			3.2	Revision: Information on SGM7A Servomotor Main Circuit Cables
			4.4.2	Addition: Information on Encoder Cables for Incremental Encoders SGM7P-08 and SGM7P-15 on Servomotors
			5.2	Addition: Information on SGM7G-30 Servomotor
			Chapter 7 and 9.1	Revision: Information on Linear Encoders from Mitutoyo Corporation
			8.1, 8.2, 8.13, 8.14, 8.15, and 9.2	Newly added.
August 2014	<1>	0	All chapters	Corrected mistakes and made changes to some parts.
			Preface, 10.8.6, Chapter 11	Deletion: Information on SigmaJunmaSize+
			Chapter 3	Addition: Information on SGM7A-40, -50, and -70
			Chapter 4	Newly added.
			Chapter 5	Addition: Information on SGM7G-30, -44, -55, -75, -1A, and -1E
			10.1.2	Addition: Power supply specifications for using a DC power supply
			10.4	Addition: Information on crimp terminals and insulating sleeves
			10.8.5	Addition: Information on Regenerative Resistor Units
10.9	Addition: Information on inrush current suppression devices			
May 2014	-	-	-	First edition

Σ-7-Series AC Servo Drive Peripheral Device Selection Manual

IRUMA BUSINESS CENTER (SOLUTION CENTER)

480, Kamifujisawa, Iruma, Saitama, 358-8555, Japan
Phone: +81-4-2962-5151 Fax: +81-4-2962-6138
www.yaskawa.co.jp

YASKAWA AMERICA, INC.

2121, Norman Drive South, Waukegan, IL 60085, U.S.A.
Phone: +1-800-YASKAWA (927-5292) or +1-847-887-7000 Fax: +1-847-887-7310
www.yaskawa.com

YASKAWA ELÉTRICO DO BRASIL LTDA.

777, Avenida Piraporinha, Diadema, São Paulo, 09950-000, Brasil
Phone: +55-11-3585-1100 Fax: +55-11-3585-1187
www.yaskawa.com.br

YASKAWA EUROPE GmbH

Philipp-Reis-Str. 6, 65795 Hattersheim am Main, Germany
Phone: +49-6196-569-300
www.yaskawa.eu.com E-mail: support@yaskawa.eu

YASKAWA ELECTRIC KOREA CORPORATION

6F, 112, LS-ro, Dongan-gu, Anyang-si, Gyeonggi-do, Korea
Phone: +82-31-8015-4224 Fax: +82-31-8015-5034
www.yaskawa.co.kr

YASKAWA ASIA PACIFIC PTE. LTD.

30A, Kallang Place, #06-01, 339213, Singapore
Phone: +65-6282-3003 Fax: +65-6289-3003
www.yaskawa.com.sg

YASKAWA ELECTRIC (THAILAND) CO., LTD.

59, 1F-5F, Flourish Building, Soi Ratchadapisek 18, Ratchadapisek Road, Huaykwang, Bangkok, 10310, Thailand
Phone: +66-2-017-0099 Fax: +66-2-017-0799
www.yaskawa.co.th

YASKAWA ELECTRIC (CHINA) CO., LTD.

22F, Link Square 1, No.222, Hubin Road, Shanghai, 200021, China
Phone: +86-21-5385-2200 Fax: +86-21-5385-3299
www.yaskawa.com.cn

YASKAWA ELECTRIC (CHINA) CO., LTD. BEIJING OFFICE

Room 1011, Tower W3 Oriental Plaza, No.1, East Chang An Avenue,
Dong Cheng District, Beijing, 100738, China
Phone: +86-10-8518-4086 Fax: +86-10-8518-4082

YASKAWA ELECTRIC TAIWAN CORPORATION

12F, No. 207, Section 3, Beishin Road, Shindian District, New Taipei City 23143, Taiwan
Phone: +886-2-8913-1333 Fax: +886-2-8913-1513 or +886-2-8913-1519
www.yaskawa.com.tw

YASKAWA**YASKAWA ELECTRIC CORPORATION**

In the event that the end user of this product is to be the military and said product is to be employed in any weapons systems or the manufacture thereof, the export will fall under the relevant regulations as stipulated in the Foreign Exchange and Foreign Trade Act. Therefore, be sure to follow all procedures and submit all relevant documentation according to any and all rules, regulations and laws that may apply. Specifications are subject to change without notice for ongoing product modifications and improvements.

© 2014 YASKAWA ELECTRIC CORPORATION

MANUAL NO. SIEP S800001 32R <17>-0

Published in Japan April 2026

25-9-21

Original instructions