

Σ -7-Series AC Servo Drive Σ -7S SERVOPACK with FT/EX Specification for Application with Special Motor, SGM7D Motor Product Manual

Model: SGD7S-□□□□□□A0□□F82

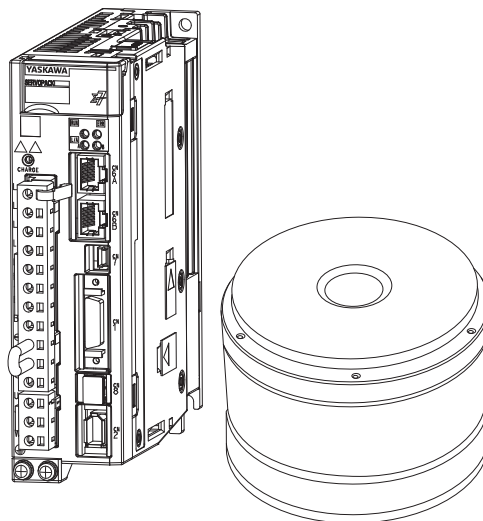

Basic Information on
SERVOPACKs

1

SERVOPACK Ratings and
Specifications

2

Maintenance

3

Parameter and Object Lists

4

Copyright © 2017 YASKAWA ELECTRIC CORPORATION

All rights reserved. No part of this publication may be reproduced, stored in a retrieval system, or transmitted, in any form, or by any means, mechanical, electronic, photocopying, recording, or otherwise, without the prior written permission of Yaskawa. No patent liability is assumed with respect to the use of the information contained herein. Moreover, because Yaskawa is constantly striving to improve its high-quality products, the information contained in this manual is subject to change without notice. Every precaution has been taken in the preparation of this manual. Nevertheless, Yaskawa assumes no responsibility for errors or omissions. Neither is any liability assumed for damages resulting from the use of the information contained in this publication.

About this Manual

This manual describes the SGM7D motor drive application option for the Σ -7-Series AC Servo Drive Σ -7S SERVOPACKs for special motors.

Read and understand this manual to ensure correct usage of the Σ -7-Series AC Servo Drives. Keep this manual in a safe place so that it can be referred to whenever necessary.

Outline of Manual

The contents of the chapters of this manual are described in the following table.

When you drive an SGM7D motor with a Σ -7-Series AC Servo Drive Σ -7S SERVOPACK for application with special motors, use this manual together with the relevant Σ -7-Series product manual.

Item		This Manual	Σ -7S SERVOPACK with EtherCAT (CoE) Communications References Product Manual (Manual No.: SIEP S800001 55)
Basic Information on SERVOPACKs	The Σ -7 Series	–	1.1
	Product Introduction	1.1	–
	Introduction to EtherCAT	–	1.2
	Interpreting the Nameplates	–	1.3
	Part Names	–	1.4
	Model Designations	1.2	–
	Combinations of SERVOPACKs and Servomotors	1.3	–
	Functions	1.4	1.7
	SigmaWin+	1.5	–
Selecting a SERVO-PACK	Ratings	2.1	–
	SERVOPACK Overload Protection Characteristics	2.2	–
	Specifications	2.3	–
	Block Diagrams	–	2.2
	External Dimensions	–	–
	Examples of Standard Connections between SERVOPACKs and Peripheral Devices	–	2.4
SERVOPACK Installation		–	Chapter 3
Wiring and Connecting SERVOPACKs		–	Chapter 4
Basic Functions That Require Setting before Operation		–	Chapter 5
Application Functions		–	Chapter 6
Trial Operation and Actual Operation		–	Chapter 7
Tuning		–	Chapter 8
Monitoring		–	Chapter 9
Fully-Closed Loop Control		–	Chapter 10
Safety Function		–	Chapter 11
EtherCAT Communications		–	Chapter 12
CiA402 Drive Profile		–	Chapter 13
Object Dictionary		–	Chapter 14

Continued on next page.

Continued from previous page.

Item		This Manual	Σ-7S SERVOPACK with EtherCAT (CoE) Communications References Product Manual (Manual No.: SIEP S800001 55)
Maintenance	Inspections and Part Replacement	–	15.1
	Alarm Displays	3.1	–
	List of Alarms	3.1.1	–
	Troubleshooting Alarms	3.1.2	–
	Resetting Alarms	–	15.2.3
	Displaying the Alarm History	–	15.2.4
	Clearing the Alarm History	–	15.2.5
	Resetting Alarms Detected in Option Modules	–	15.2.6
	Resetting Motor Type Alarms	–	15.2.7
	Warning Displays	3.2	–
Troubleshooting Based on the Operation and Conditions of the Servomotor	3.3	–	
Parameter and Object Lists	List of Parameters	4.1	–
	Object List	4.2	–
	SDO Abort Code List	4.3	–
	Parameter Recording Table	4.4	–
Appendix	Interpreting Panel Displays	–	17.1
	Corresponding SERVOPACK and SigmaWin+ Function Names	–	17.2

Related Documents

The relationships between the documents that are related to the Servo Drives are shown in the following figure. The numbers in the figure correspond to the numbers in the table on the following pages. Refer to these documents as required.

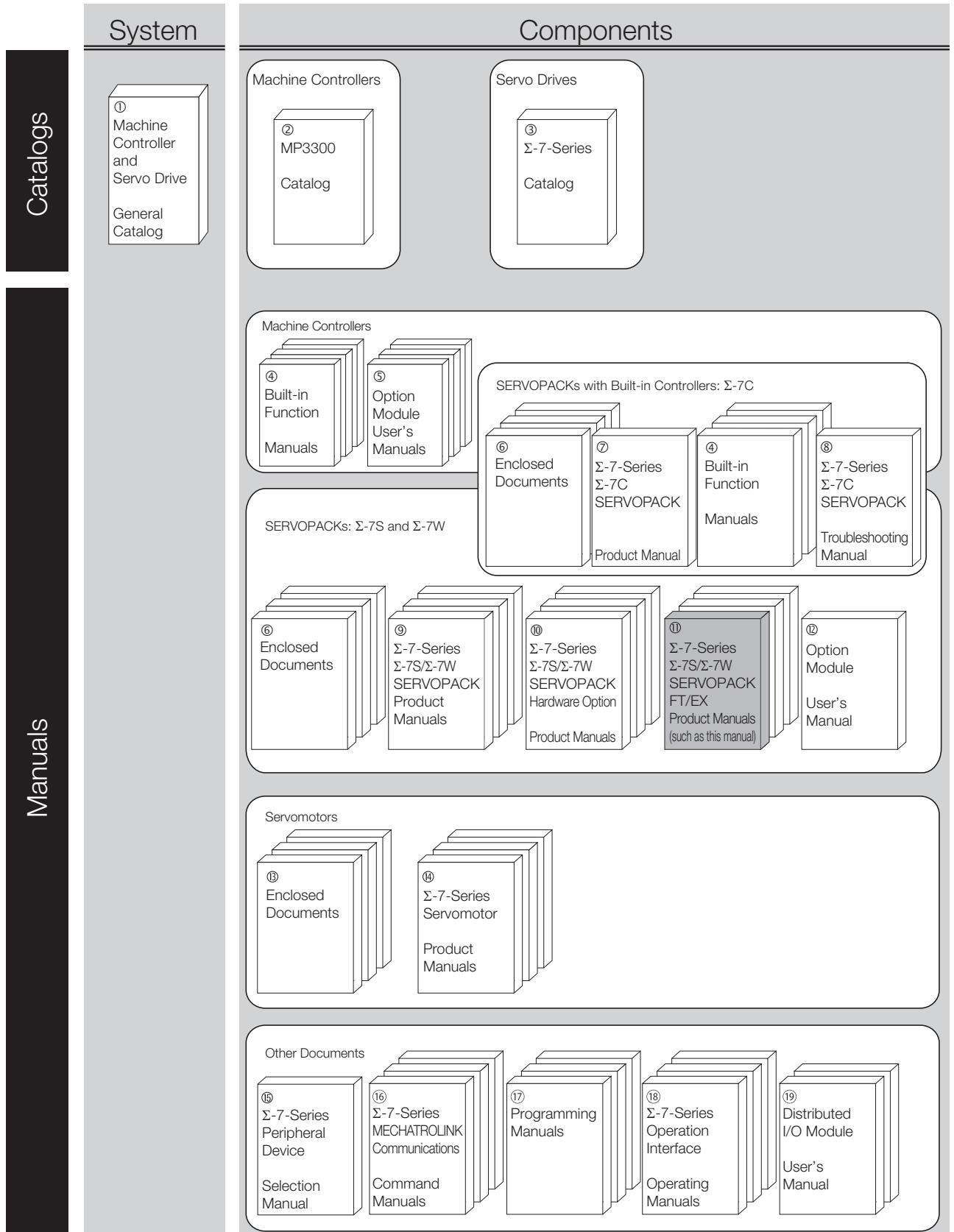

Classification	Document Name	Document No.	Description
① Machine Controller and Servo Drive General Catalog	Machine Controller and AC Servo Drive Solutions Catalog	KAEP S800001 22	Describes the features and application examples for combinations of MP3000-Series Machine Controllers and Σ -7-Series AC Servo Drives.
② MP3300 Catalog	Machine Controller MP3300	KAEP C880725 03	Provides detailed information on MP3300 Machine Controllers, including features and specifications.
③ Σ -7-Series Catalog	AC Servo Drives Σ -7 Series	KAEP S800001 23	Provides detailed information on Σ -7-Series AC Servo Drives, including features and specifications.
④ Built-in Function Manuals	Σ -7-Series AC Servo Drive Σ -7C SERVOPACK Motion Control User's Manual	SIEP S800002 03	Provides detailed information on the specifications, system configuration, and application methods of the Motion Control Function Modules (SVD, SVC4, and SVR4) for Σ -7-Series Σ -7C SERVOPACKs.
	Machine Controller MP3000 Series Communications User's Manual	SIEP C880725 12	Provides detailed information on the specifications, system configuration, and communications connection methods for the Ethernet communications that are used with MP3000-Series Machine Controllers and Σ -7-Series Σ -7C SERVOPACKs.
⑤ Option Module User's Manuals	Machine Controller MP2000 Series Communication Module User's Manual	SIEP C880700 04	Provide detailed information on the specifications and communications methods for the Communications Modules that can be mounted to MP3000-Series Machine Controllers and Σ -7-Series Σ -7C SERVOPACKs.
	Machine Controller MP2000 Series 262IF-01 FL-net Communication Module User's Manual	SIEP C880700 36	
	Machine Controller MP2000 Series 263IF-01 EtherNet/IP Communication Module User's Manual	SIEP C880700 39	
	Machine Controller MP2000 Series I/O Module User's Manual	SIEP C880700 34	Provide detailed information on the specifications and communications methods for the I/O Modules that can be mounted to MP3000-Series Machine Controllers and Σ -7-Series Σ -7C SERVOPACKs.
	Machine Controller MP2000 Series Analog Input/Analog Output Module AI-01/AO-01 User's Manual	SIEP C880700 26	
	Machine Controller MP2000 Series Counter Module CNTR-01 User's Manual	SIEP C880700 27	

Continued on next page.

Continued from previous page.

Classification	Document Name	Document No.	Description
⑥ Enclosed Documents	Σ-7-Series AC Servo Drive Σ-7S, Σ-7W, and Σ-7C SER- VOPACK Safety Precautions	TOMP C710828 00	Provides detailed information for the safe usage of Σ-7-Series SERVOPACKs.
	Σ-V-Series/Σ-V-Series for Large-Capacity Models/ Σ-7-Series Safety Precautions Option Module	TOBP C720829 00	Provides detailed information for the safe usage of Option Modules.
	Σ-V-Series/Σ-V-Series for Large-Capacity Models/ Σ-7-Series Installation Guide Command Option Module	TOBP C720829 01	Provides detailed procedures for installing the Command Option Module in a SERVOPACK.
	Σ-V-Series/Σ-V-Series for Large-Capacity Models/ Σ-7-Series Installation Guide Fully-closed Module	TOBP C720829 03	Provides detailed procedures for installing the Fully-closed Module in a SERVOPACK.
	Σ-V-Series/Σ-V-Series for Large-Capacity Models/ Σ-7-Series Installation Guide Safety Module	TOBP C720829 06	Provides detailed procedures for installing the Safety Module in a SERVOPACK.
	Σ-V-Series/Σ-V-Series for Large-Capacity Models/ Σ-7-Series Installation Guide INDEXER Module	TOBP C720829 02	Provides detailed procedures for installing the INDEXER Module in a SERVOPACK.
	Σ-V-Series/Σ-V-Series for Large-Capacity Models/ Σ-7-Series Installation Guide DeviceNet Module	TOBP C720829 07	Provides detailed procedures for installing the DeviceNet Module in a SERVOPACK.
⑦ Σ-7-Series Σ-7C SERVOPACK Product Manual	Σ-7-Series AC Servo Drive Σ-7C SERVOPACK Product Manual	SIEP S800002 04	Provides detailed information on selecting Σ-7-Series Σ-7C SERVOPACKs; installing, connecting, setting, testing in trial operation, and tuning Servo Drives; writing, monitoring, and maintaining programs; and other information.
⑧ Σ-7-Series Σ-7C SERVOPACK Troubleshooting Manual	Σ-7-Series AC Servo Drive Σ-7C SERVOPACK Troubleshooting Manual	SIEP S800002 07	Provides detailed troubleshooting information for Σ-7-Series Σ-7C SERVOPACKs.

Continued on next page.

Continued from previous page.

Classification	Document Name	Document No.	Description
⑨ Σ-7-Series Σ-7S/Σ-7W SERVOPACK Product Manuals	Σ-7-Series AC Servo Drive Σ-7S SERVOPACK with MECHATROLINK-4 Communications References Product Manual	SIEP S800002 31	Provide detailed information on selecting Σ-7-Series Σ-7S and Σ-7W SERVOPACKs; installing, connecting, setting, testing in trial operation, tuning, monitoring, and maintaining Servo Drives; and other information.
	Σ-7-Series AC Servo Drive Σ-7S SERVOPACK with MECHATROLINK-III Communications References Product Manual	SIEP S800001 28	
	Σ-7-Series AC Servo Drive Σ-7S SERVOPACK with MECHATROLINK-II Communications References Product Manual	SIEP S800001 27	
	Σ-7-Series AC Servo Drive Σ-7S SERVOPACK with Analog Voltage/Pulse Train References Product Manual	SIEP S800001 26	
	Σ-7-Series AC Servo Drive Σ-7S SERVOPACK Command Option Attachable Type with INDEXER Module Product Manual	SIEP S800001 64	
	Σ-7-Series AC Servo Drive Σ-7S SERVOPACK Command Option Attachable Type with DeviceNet Module Product Manual	SIEP S800001 70	
	Σ-7-Series AC Servo Drive Σ-7S SERVOPACK with EtherCAT (CoE) Communica- tions References Product Manual	SIEP S800001 55	
	Σ-7-Series AC Servo Drive Σ-7W SERVOPACK with MECHATROLINK-III Communications References Product Manual	SIEP S800001 29	
⑩ Σ-7-Series Σ-7S/Σ-7W SERVOPACK with Hardware Option Specifications Product Manuals	Σ-7-Series AC Servo Drive Σ-7S/Σ-7W SERVOPACK with Hardware Option Specifica- tions Dynamic Brake Product Manual	SIEP S800001 73	Provide detailed information on Hardware Options for Σ-7-Series SERVOPACKs.
	Σ-7-Series AC Servo Drive Σ-7W/Σ-7C SERVOPACK with Hardware Option Specifica- tions HWBB Function Product Manual	SIEP S800001 72	

Continued on next page.

Continued from previous page.

Classification	Document Name	Document No.	Description
⑩ Σ-7-Series Σ-7S/Σ-7W SERVOPACK FT/EX Product Manuals	Σ-7-Series AC Servo Drive Σ-7S SERVOPACK with FT/EX Specification for Indexing Application Product Manual	SIEP S800001 84	Provide detailed information on the FT/EX Option for Σ-7-Series SERVOPACKs.
	Σ-7-Series AC Servo Drive Σ-7S SERVOPACK with FT/EX Specification for Tracking Application Product Manual	SIEP S800001 89	
	Σ-7-Series AC Servo Drive Σ-7S SERVOPACK with FT/EX Specification for Application with Special Motor, SGM7D Motor Product Manual	SIEP S800001 91	
	Σ-7-Series AC Servo Drive Σ-7S SERVOPACK with FT/EX Specification for Press and Injection Molding Application Product Manual	SIEP S800001 94	
	Σ-7-Series AC Servo Drive Σ-7S SERVOPACK with FT/EX Specification for Transfer and Alignment Application Product Manual	SIEP S800001 95	
	Σ-7-Series AC Servo Drive Σ-7S SERVOPACK with FT/EX Specification for Torque/Force Assistance for Conveyance Application Product Manual	SIEP S800002 09	
	Σ-7-Series AC Servo Drive Σ-7S SERVOPACK with FT/EX Specification for Cutting Application Feed Shaft Motor Product Manual	SIEP S800002 10	
	Σ-7-Series AC Servo Drive Σ-7S SERVOPACK with FT/EX Specification for Three-Point Latching for Conveyance Application Product Manual	SIEP S800002 17	
	Σ-7-Series AC Servo Drive Σ-7S SERVOPACK with FT/EX Specification with Special Motor, SGM7D Motor Product Manual	This manual (SIEP S800002 26)	
	Σ-7-Series AC Servo Drive Σ-7S SERVOPACK with FT/EX Specification for Semi-/Fully-Closed Loop Control Online Switching for Conveyance Application Product Manual	SIEP S800002 27	

Continued on next page.

Continued from previous page.

Classification	Document Name	Document No.	Description
⑪ Σ-7-Series Σ-7S/Σ-7W SERVOPACK FT/EX Product Manuals	Σ-7-Series AC Servo Drive Σ-7W SERVOPACK with FT/EX Specification for Gantry Applications Product Manual	SIEP S800002 29	Provide detailed information on the FT/EX Option for Σ-7-Series SERVOPACKs.
⑫ Option Module User's Manual	AC Servo Drives Σ-V Series/Σ-V Series for Large-Capacity Models/ Σ-7 Series User's Manual Safety Module	SIEP C720829 06	Provides detailed information required for the design and maintenance of a Safety Module.
⑬ Enclosed Documents	AC Servo Drive Rotary Servomotor Safety Precautions	TOBP C230260 00	Provides detailed information for the safe usage of Rotary Servomotors and Direct Drive Servomotors.
	AC Servomotor Linear Σ Series Safety Precautions	TOBP C230800 00	Provides detailed information for the safe usage of Linear Servomotors.
⑭ Σ-7-Series Servomotor Product Manuals	Σ-7-Series AC Servo Drive Rotary Servomotor Product Manual	SIEP S800001 36	Provide detailed information on selecting, installing, and connecting the Σ-7-Series Servomotors.
	Σ-7-Series AC Servo Drive Linear Servomotor Product Manual	SIEP S800001 37	
	Σ-7-Series AC Servo Drive Direct Drive Servomotor Product Manual	SIEP S800001 38	
⑮ Σ-7-Series Peripheral Device Selection Manual	Σ-7-Series AC Servo Drive Peripheral Device Selection Manual	SIEP S800001 32	Provides the following information in detail for Σ-7-Series Servo Systems. <ul style="list-style-type: none"> • Cables: Models, dimensions, wiring materials, connector models, and connection specifications • Peripheral devices: Models, specifications, diagrams, and selection (calculation) methods
⑯ Σ-7-Series MECHATROLINK Communications Command Manuals	Σ-7-Series AC Servo Drive MECHATROLINK-II Communications Command Manual	SIEP S800001 30	Provides detailed information on the MECHATROLINK-II communications commands that are used for a Σ-7-Series Servo System.
	Σ-7-Series AC Servo Drive MECHATROLINK-III Communications Standard Servo Profile Command Manual	SIEP S800001 31	Provides detailed information on the MECHATROLINK-III communications standard servo profile commands that are used for a Σ-7-Series Servo System.
	Σ-7-Series AC Servo Drive MECHATROLINK-4 Communications Standard Servo Profile Command Manual	SIEP S800002 32	Provides detailed information on the MECHATROLINK-4 communications standard servo profile commands that are used for a Σ-7-Series Servo System.
⑰ Programming Manuals	Machine Controller MP3000 Series Ladder Programming Manual	SIEP C880725 13	Provides detailed information on the ladder programming specifications and instructions for MP3000-Series Machine Controllers and Σ-7-Series Σ-7C SERVOPACKs.
	Machine Controller MP3000 Series Motion Programming Manual	SIEP C880725 14	Provides detailed information on the motion programming and sequence programming specifications and instructions for MP3000-Series Machine Controllers and Σ-7-Series Σ-7C SERVOPACKs.

Continued on next page.



Continued from previous page.

Classification	Document Name	Document No.	Description
[®] Σ-7-Series Operation Interface Operating Manuals	System Integrated Engineering Tool MPE720 Version 7 USER'S MANUAL	SIEP C880761 03	Describes in detail how to operate MPE720 version 7.
	Σ-7-Series AC Servo Drive Digital Operator Operating Manual	SIEP S800001 33	Describes the operating procedures for a Digital Operator for a Σ-7-Series Servo System.
	AC Servo Drive Engineering Tool SigmaWin+ Operation Manual	SIET S800001 34	Provides detailed operating procedures for the SigmaWin+ Engineering Tool for a Σ-7-Series Servo System.
[®] Distributed I/O Module User's Manual	MECHATROLINK-III Compatible I/O Module User's Manual	SIEP C880781 04	Describes the functions, specifications, operating methods, and MECHATROLINK-III communications for the Remote I/O Modules for MP2000/MP3000-Series Machine Controllers.
	MECHATROLINK-4 Compatible I/O Module User's Manual	SIEP C880782 01	Describes the functions, specifications, operating methods, and MECHATROLINK-4 communications for the Remote I/O Modules for MP3000-Series Machine Controllers.

Using This Manual

◆ Technical Terms Used in This Manual

The following terms are used in this manual.

Term	Meaning
Servomotor	A Σ -7-Series Direct Drive Servomotor.
SERVOPACK	A Σ -7-Series Σ -7S Servo Amplifier with EtherCAT Communications References.
Servo Drive	The combination of a Servomotor and SERVOPACK.
Servo System	A servo control system that includes the combination of a Servo Drive with a host controller and peripheral devices.
servo ON	Supplying power to the motor.
servo OFF	Not supplying power to the motor.
Servo ON command (Enable Operation command)	A command that is used to turn ON the servo (i.e., supply power to the motor) when bit 3 of <i>controlword</i> (6040h) is changed to 1 (ON) while the control power supply and main circuit power supply are ON. Refer to the following manual for details.  Σ -7-Series Σ -7S SERVOPACK with EtherCAT (CoE) Communications References Product Manual (Manual No.: SIEP S800001 55)
Servo OFF command (Disable Operation command)	A command that is used to turn OFF the servo (i.e., power not supplied to the motor) when bit 3 of <i>controlword</i> (6040h) is changed to 0 (OFF) while the control power supply and main circuit power supply are ON. Refer to the following manual for details.  Σ -7-Series Σ -7S SERVOPACK with EtherCAT (CoE) Communications References Product Manual (Manual No.: SIEP S800001 55)
base block (BB)	Shutting OFF the power supply to the motor by shutting OFF the base current to the power transistor in the SERVOPACK.
servo lock	A state in which the motor is stopped and is in a position loop with a position reference of 0.
Main Circuit Cable	One of the cables that connect to the main circuit terminals, including the Main Circuit Power Supply Cable, Control Power Supply Cable, and Servomotor Main Circuit Cable.
SigmaWin+	The Engineering Tool for setting up and tuning Servo Drives or a computer in which the Engineering Tool is installed.
MDevice	An abbreviation for a MainDevice.
SubDevice	An abbreviation for a SubordinateDevice.

◆ Notation Used in this Manual

■ Notation for Reverse Signals

The names of reverse signals (i.e., ones that are valid when low) are written with a forward slash (/) before the signal abbreviation.

Notation Example

\overline{BK} is written as /BK.

■ Notation for Parameters

The notation depends on whether the parameter requires a numeric setting (parameter for numeric setting) or requires the selection of a function (parameter for selecting functions).

• Parameters for Numeric Settings

The control methods for which the parameters apply are given.
Speed: Speed control Position: Position control Torque: Torque control

Parameter number Pn100 (2100h)	Speed Loop Gain					Speed Position
	Setting Range	Setting Unit	Default Setting	When Enabled	Classification	
	10 to 20,000	0.1 Hz	400	Immediately	Tuning	

Object index number used to access the parameter with EtherCAT (CoE) communications

This is the setting range for the parameter.

This is the minimum unit (setting increment) that you can set for the parameter.

This is the parameter setting before shipment.

This is when any change made to the parameter will become effective.

This is the parameter classification.

• Parameters for Selecting Functions

Parameter number	Parameter	Meaning	When Enabled	Classification
Pn002 (2002h)	n.□□□□ (default setting)	Use the encoder according to encoder specifications.	After restart	Setup
	n.□1□□	Use the encoder as an incremental encoder.		
	n.□2□□	Use the encoder as a single-turn absolute encoder.		

Object index number used to access the parameter with EtherCAT (CoE) communications

The notation "n.□□□□" indicates a parameter for selecting functions. Each □ indicates the setting for one digit. The notation shown here means that the third digit from the right is set to 2.

This column explains the selections for the function.

Notation Example

Notation Examples for Pn002

Notation	Digit Notation		Numeric Value Notation	
	Notation	Meaning	Notation	Meaning
n.0000	Pn002 = n.□□□X	Indicates the first digit from the right in Pn002.	Pn002 = n.□□□1	Indicates that the first digit from the right in Pn002 is set to 1.
	Pn002 = n.□□X□	Indicates the second digit from the right in Pn002.	Pn002 = n.□□1□	Indicates that the second digit from the right in Pn002 is set to 1.
	Pn002 = n.□X□□	Indicates the third digit from the right in Pn002.	Pn002 = n.□1□□	Indicates that the third digit from the right in Pn002 is set to 1.
	Pn002 = n.X□□□	Indicates the fourth digit from the right in Pn002.	Pn002 = n.1□□□	Indicates that the fourth digit from the right in Pn002 is set to 1.

◆ Engineering Tools Used in This Manual

This manual uses the interfaces of the SigmaWin+ for descriptions.

◆ Trademarks

- EtherCAT® is a registered trademark and patented technology, licensed by Beckhoff Automation GmbH, Germany.
- QR code is a trademark of Denso Wave Inc.
- Other product names and company names are the trademarks or registered trademarks of the respective company. “TM” and the ® mark do not appear with product or company names in this manual.

◆ Visual Aids

The following aids are used to indicate certain types of information for easier reference.



Indicates precautions or restrictions that must be observed.
Also indicates alarm displays and other precautions that will not result in machine damage.



Indicates definitions of difficult terms or terms that have not been previously explained in this manual.

Example Indicates operating or setting examples.

Information Indicates supplemental information to deepen understanding or useful information.

Safety Precautions

◆ Safety Information

To prevent personal injury and equipment damage in advance, the following signal words are used to indicate safety precautions in this document. The signal words are used to classify the hazards and the degree of damage or injury that may occur if a product is used incorrectly. Information marked as shown below is important for safety. Always read this information and heed the precautions that are provided.



DANGER

- Indicates precautions that, if not heeded, are likely to result in loss of life, serious injury, or fire.



WARNING

- Indicates precautions that, if not heeded, could result in loss of life, serious injury, or fire.



CAUTION

- Indicates precautions that, if not heeded, could result in relatively serious or minor injury, or in fire.

NOTICE

- Indicates precautions that, if not heeded, could result in property damage.

◆ Safety Precautions That Must Always Be Observed

■ General Precautions



DANGER

- Read and understand this manual to ensure the safe usage of the product.
- Keep this manual in a safe, convenient place so that it can be referred to whenever necessary. Make sure that it is delivered to the final user of the product.
- Do not remove covers, cables, connectors, or optional devices while power is being supplied to the SERVOPACK.
There is a risk of electric shock, operational failure of the product, or burning.



WARNING

- Use a power supply with specifications (number of phases, voltage, frequency, and AC/DC type) that are appropriate for the product.
There is a risk of burning, electric shock, or fire.
- Connect the ground terminals on the SERVOPACK and Servomotor to ground poles according to local electrical codes (100 Ω or less for a SERVOPACK with a 100-VAC or 200-VAC power supply, and 10 Ω or less for a SERVOPACK with a 400-VAC power supply).
There is a risk of electric shock or fire.
- Do not attempt to disassemble, repair, or modify the product.
There is a risk of fire or failure.
The warranty is void for the product if you disassemble, repair, or modify it.



CAUTION

- The SERVOPACK heat sinks, regenerative resistors, External Dynamic Brake Resistors, Servomotors, and other components can be very hot while power is ON or soon after the power is turned OFF. Implement safety measures, such as installing covers, so that hands and parts such as cables do not come into contact with hot components.
There is a risk of burn injury.
- For a 24-VDC power supply, use a power supply device with double insulation or reinforced insulation.
There is a risk of electric shock.
- Do not damage, pull on, apply excessive force to, place heavy objects on, or pinch cables.
There is a risk of failure, damage, or electric shock.
- The person who designs the system that uses the hard wire base block safety function must have a complete knowledge of the related safety standards and a complete understanding of the instructions in this document.
There is a risk of injury, product damage, or machine damage.
- Do not use the product in an environment that is subject to water, corrosive gases, or flammable gases, or near flammable materials.
There is a risk of electric shock or fire.

NOTICE

- Do not attempt to use a SERVOPACK or Servomotor that is damaged or that has missing parts.
- Install external emergency stop circuits that shut OFF the power supply and stops operation immediately when an error occurs.
- In locations with poor power supply conditions, install the necessary protective devices (such as AC reactors) to ensure that the input power is supplied within the specified voltage range. There is a risk of damage to the SERVOPACK.
- Use a Noise Filter to minimize the effects of electromagnetic interference. Electronic devices used near the SERVOPACK may be affected by electromagnetic interference.
- Always use a Servomotor and SERVOPACK in one of the specified combinations.
- Do not touch a SERVOPACK or Servomotor with wet hands. There is a risk of product failure.

■ Storage Precautions



CAUTION

- Do not place an excessive load on the product during storage. (Follow all instructions on the packages.) There is a risk of injury or damage.

NOTICE

- Do not install or store the product in any of the following locations.
 - Locations that are subject to direct sunlight
 - Locations that are subject to ambient temperatures that exceed product specifications
 - Locations that are subject to relative humidities that exceed product specifications
 - Locations that are subject to condensation as the result of extreme changes in temperature
 - Locations that are subject to corrosive or flammable gases
 - Locations that are near flammable materials
 - Locations that are subject to dust, salts, or iron powder
 - Locations that are subject to water, oil, or chemicals
 - Locations that are subject to vibration or shock that exceeds product specifications
 - Locations that are subject to radiationIf you store or install the product in any of the above locations, the product may fail or be damaged.

■ Transportation Precautions



CAUTION

- Transport the product in a way that is suitable to the mass of the product.
- Do not use the eyebolts on a SERVOPACK or Servomotor to move the machine. There is a risk of damage or injury.
- When you handle a SERVOPACK or Servomotor, be careful of sharp parts, such as the corners. There is a risk of injury.
- Do not place an excessive load on the product during transportation. (Follow all instructions on the packages.) There is a risk of injury or damage.

NOTICE

- Do not hold onto the front cover or connectors when you move a SERVOPACK.
There is a risk of the SERVOPACK falling.
- A SERVOPACK or Servomotor is a precision device. Do not drop it or subject it to strong shock.
There is a risk of failure or damage.
- Do not subject connectors to shock.
There is a risk of faulty connections or damage.
- If disinfectants or insecticides must be used to treat packing materials such as wooden frames, plywood, or pallets, the packing materials must be treated before the product is packaged, and methods other than fumigation must be used.
Example: Heat treatment, where materials are kiln-dried to a core temperature of 56°C for 30 minutes or more.
If the electronic products, which include stand-alone products and products installed in machines, are packed with fumigated wooden materials, the electrical components may be greatly damaged by the gases or fumes resulting from the fumigation process. In particular, disinfectants containing halogen, which includes chlorine, fluorine, bromine, or iodine can contribute to the erosion of the capacitors.
- Do not overtighten the eyebolts on a SERVOPACK or Servomotor.
If you use a tool to overtighten the eyebolts, the tapped holes may be damaged.

■ Installation Precautions



CAUTION

- Install the Servomotor or SERVOPACK in a way that will support the mass given in technical documents.
- Install SERVOPACKs, Servomotors, regenerative resistors, and External Dynamic Brake Resistors on nonflammable materials.
Installation directly onto or near flammable materials may result in fire.
- Provide the specified clearances between the SERVOPACK and the control panel as well as with other devices.
There is a risk of fire or failure.
- Install the SERVOPACK in the specified orientation.
There is a risk of fire or failure.
- Do not step on or place a heavy object on the product.
There is a risk of failure, damage, or injury.
- Do not allow any foreign matter to enter the SERVOPACK or Servomotor.
There is a risk of failure or fire.

NOTICE

- **Do not install or store the product in any of the following locations.**
 - Locations that are subject to direct sunlight
 - Locations that are subject to ambient temperatures that exceed product specifications
 - Locations that are subject to relative humidities that exceed product specifications
 - Locations that are subject to condensation as the result of extreme changes in temperature
 - Locations that are subject to corrosive or flammable gases
 - Locations that are near flammable materials
 - Locations that are subject to dust, salts, or iron powder
 - Locations that are subject to water, oil, or chemicals
 - Locations that are subject to vibration or shock that exceeds product specifications
 - Locations that are subject to radiationIf you store or install the product in any of the above locations, the product may fail or be damaged.
- **Use the product in an environment that is appropriate for the product specifications.**

If you use the product in an environment that exceeds product specifications, the product may fail or be damaged.
- **A SERVOPACK or Servomotor is a precision device. Do not drop it or subject it to strong shock.**

There is a risk of failure or damage.
- **Always install a SERVOPACK in a control panel.**
- **Do not allow any foreign matter to enter a SERVOPACK or a Servomotor with a Cooling Fan and do not cover the outlet from the Servomotor's cooling fan.**

There is a risk of failure.

■ Wiring Precautions



DANGER

- **Do not change any wiring while power is being supplied.**

There is a risk of electric shock or injury.



WARNING

- **Wiring and inspections must be performed only by qualified engineers.**

There is a risk of electric shock or product failure.
- **Check all wiring and power supplies carefully.**

Incorrect wiring or incorrect voltage application to the output circuits may cause short-circuit failures. If a short-circuit failure occurs as a result of any of these causes, the holding brake will not work. This could damage the machine or cause an accident that may result in death or injury.
- **Connect the AC and DC power supplies to the specified SERVOPACK terminals.**
 - Connect an AC power supply to the L1, L2, and L3 terminals and the L1C and L2C terminals on the SERVOPACK.
 - Connect a DC power supply to the B1/⊕ and ⊖2 terminals and the L1C and L2C terminals on the SERVOPACK.

There is a risk of failure or fire.
- **If you use a SERVOPACK that supports a Dynamic Brake Option, connect an External Dynamic Brake Resistor that is suitable for the machine and equipment specifications to the specified terminals.**

There is a risk of unexpected operation, machine damage, burning, or injury when an emergency stop is performed.



CAUTION

- Wait for six minutes after turning OFF the power supply and then make sure that the CHARGE indicator is not lit before starting wiring or inspection work. Do not touch the power supply terminals while the CHARGE lamp is lit after turning OFF the power supply because high voltage may still remain in the SERVOPACK.
There is a risk of electric shock.
- Observe the precautions and instructions for wiring and trial operation precisely as described in this document.
Failures caused by incorrect wiring or incorrect voltage application in the brake circuit may cause the SERVOPACK to fail, damage the equipment, or cause an accident resulting in death or injury.
- Check the wiring to be sure it has been performed correctly.
Connectors and pin layouts are sometimes different for different models. Always confirm the pin layouts in technical documents for your model before operation.
There is a risk of failure or malfunction.
- Connect wires to power supply terminals and motor connection terminals securely with the specified methods and tightening torque.
Insufficient tightening may cause wires and terminal blocks to generate heat due to faulty contact, possibly resulting in fire.
- Use shielded twisted-pair cables or screened unshielded multi-twisted-pair cables for I/O Signal Cables and Encoder Cables.
- The maximum wiring length is 3 m for I/O Signal Cables, and 50 m for Encoder Cables or Servomotor Main Circuit Cables.
- Observe the following precautions when wiring the SERVOPACK's main circuit terminals.
 - Turn ON the power supply to the SERVOPACK only after all wiring, including the main circuit terminals, has been completed.
 - If a connector is used for the main circuit terminals, remove the main circuit connector from the SERVOPACK before you wire it.
 - Insert only one wire per insertion hole in the main circuit terminals.
 - When you insert a wire, make sure that the conductor wire (e.g., whiskers) does not come into contact with adjacent wires.
- Install molded-case circuit breakers and other safety measures to provide protection against short circuits in external wiring.
There is a risk of fire or failure.

NOTICE

- Whenever possible, use the Cables specified by Yaskawa.
If you use any other cables, confirm the rated current and application environment of your model and use the wiring materials specified by Yaskawa or equivalent materials.
- Securely tighten connector screws and lock mechanisms.
Insufficient tightening may result in connectors falling off during operation.
- Do not bundle power lines (e.g., the Main Circuit Cable) and low-current lines (e.g., the I/O Signal Cables or Encoder Cables) together or run them through the same duct. If you do not place power lines and low-current lines in separate ducts, separate them by at least 30 cm.
If the cables are too close to each other, malfunctions may occur due to noise affecting the low-current lines.
- Install a battery at either the host controller or on the Encoder Cable.
If you install batteries both at the host controller and on the Encoder Cable at the same time, you will create a loop circuit between the batteries, resulting in a risk of damage or burning.
- When connecting a battery, connect the polarity correctly.
There is a risk of battery rupture or encoder failure.

■ Operation Precautions



WARNING

- Before starting operation with a machine connected, change the settings of the switches and parameters to match the machine.
Unexpected machine operation, failure, or personal injury may occur if operation is started before appropriate settings are made.
- Do not radically change the settings of the parameters.
There is a risk of unstable operation, machine damage, or injury.
- Install limit switches or stoppers at the ends of the moving parts of the machine to prevent unexpected accidents.
There is a risk of machine damage or injury.
- For trial operation, securely mount the Servomotor and disconnect it from the machine.
There is a risk of injury.
- Forcing the motor to stop for overtravel is disabled when the Jog, Origin Search, or Easy FFT utility function is executed. Take necessary precautions.
There is a risk of machine damage or injury.
- When an alarm occurs, the Servomotor will coast to a stop or stop with the dynamic brake according to the SERVOPACK Option specifications and settings. The coasting distance will change with the moment of inertia of the load and the resistance of the External Dynamic Brake Resistor. Check the coasting distance during trial operation and implement suitable safety measures on the machine.
- Do not enter the machine's range of motion during operation.
There is a risk of injury.
- Do not touch the moving parts of the Servomotor or machine during operation.
There is a risk of injury.



CAUTION

- Design the system to ensure safety even when problems, such as broken signal lines, occur. For example, the P-OT and N-OT signals are set in the default settings to operate on the safe side if a signal line breaks. Do not change the polarity of this type of signal.
- When overtravel occurs, the power supply to the motor is turned OFF and the brake is released. If you use the Servomotor to drive a vertical load, set the Servomotor to enter a zero-clamped state after the Servomotor stops. Also, install safety devices (such as an external brake or counterweight) to prevent the moving parts of the machine from falling.
- Always turn OFF the servo before you turn OFF the power supply. If you turn OFF the main circuit power supply or control power supply during operation before you turn OFF the servo, the Servomotor will stop as follows:
 - If you turn OFF the main circuit power supply during operation without turning OFF the servo, the Servomotor will stop abruptly with the dynamic brake.
 - If you turn OFF the control power supply without turning OFF the servo, the stopping method that is used by the Servomotor depends on the model of the SERVOPACK. For details, refer to the manual for the SERVOPACK.
 - If you use a SERVOPACK that supports a Dynamic Brake Option, the Servomotor stopping methods will be different from the stopping methods used without the Option or for other Hardware Option specifications. For details, refer to the *Σ-7-Series AC Servo Drive Σ-7S/Σ-7W SERVOPACK with Hardware Option Specifications Dynamic Brake Product Manual*.
- Do not use the dynamic brake for any application other than an emergency stop.
There is a risk of failure due to rapid deterioration of elements in the SERVOPACK and the risk of unexpected operation, machine damage, burning, or injury.

NOTICE

- When you adjust the gain during system commissioning, use a measuring instrument to monitor the torque waveform and speed waveform and confirm that there is no vibration.
If a high gain causes vibration, the Servomotor will be damaged quickly.
- Do not frequently turn the power supply ON and OFF. After you have started actual operation, allow at least one hour between turning the power supply ON and OFF (as a guideline).
Do not use the product in applications that require the power supply to be turned ON and OFF frequently.
The elements in the SERVOPACK will deteriorate quickly.
- An alarm or warning may occur if communications are performed with the host controller while the SigmaWin+ or Digital Operator is operating.
If an alarm or warning occurs, it may interrupt the current process and stop the system.
- After you complete trial operation of the machine and facilities, use the SigmaWin+ to back up the settings of the SERVOPACK parameters. You can use them to reset the parameters after SERVOPACK replacement.
If you do not copy backed up parameter settings, normal operation may not be possible after a faulty SERVOPACK is replaced, possibly resulting in machine or equipment damage.

■ Maintenance and Inspection Precautions

DANGER

- Do not change any wiring while power is being supplied.
There is a risk of electric shock or injury.

WARNING

- Wiring and inspections must be performed only by qualified engineers.
There is a risk of electric shock or product failure.

CAUTION

- Wait for six minutes after turning OFF the power supply and then make sure that the CHARGE indicator is not lit before starting wiring or inspection work. Do not touch the power supply terminals while the CHARGE lamp is lit after turning OFF the power supply because high voltage may still remain in the SERVOPACK.
There is a risk of electric shock.
- Before you replace a SERVOPACK, back up the settings of the SERVOPACK parameters. Copy the backed up parameter settings to the new SERVOPACK and confirm that they were copied correctly.
If you do not copy backed up parameter settings or if the copy operation is not completed normally, normal operation may not be possible, possibly resulting in machine or equipment damage.

NOTICE

- Discharge all static electricity from your body before you operate any of the buttons or switches inside the front cover of the SERVOPACK.
There is a risk of equipment damage.

■ Troubleshooting Precautions



DANGER

- If the safety device (molded-case circuit breaker or fuse) installed in the power supply line operates, remove the cause before you supply power to the SERVOPACK again. If necessary, repair or replace the SERVOPACK, check the wiring, and remove the factor that caused the safety device to operate.

There is a risk of fire, electric shock, or injury.



WARNING

- The product may suddenly start to operate when the power supply is recovered after a momentary power interruption. Design the machine to ensure human safety when operation restarts.

There is a risk of injury.



CAUTION

- When an alarm occurs, remove the cause of the alarm and ensure safety. Then reset the alarm or turn the power supply OFF and ON again to restart operation.
There is a risk of injury or machine damage.
- If the Servo ON signal is input to the SERVOPACK and an alarm is reset, the Servomotor may suddenly restart operation. Confirm that the servo is OFF and ensure safety before you reset an alarm.
There is a risk of injury or machine damage.
- Always insert a magnetic contactor in the line between the main circuit power supply and the main circuit power supply terminals on the SERVOPACK so that the power supply can be shut OFF at the main circuit power supply.
If a magnetic contactor is not connected when the SERVOPACK fails, a large current may flow, possibly resulting in fire.
- If an alarm occurs, shut OFF the main circuit power supply.
There is a risk of fire due to a regenerative resistor overheating as the result of regenerative transistor failure.
- Install a ground fault detector against overloads and short-circuiting or install a molded-case circuit breaker combined with a ground fault detector.
There is a risk of SERVOPACK failure or fire if a ground fault occurs.
- The holding brake on a Servomotor will not ensure safety if there is the possibility that an external force (including gravity) may move the current position and create a hazardous situation when power is interrupted or an error occurs. If an external force may cause movement, install an external braking mechanism that ensures safety.

■ Disposal Precautions

- Correctly discard the product as stipulated by regional, local, and municipal laws and regulations. Be sure to include these contents in all labelling and warning notifications on the final product as necessary.



■ General Precautions

- Figures provided in this document are typical examples or conceptual representations. There may be differences between them and actual wiring, circuits, and products.
- The products shown in illustrations in this document are sometimes shown without covers or protective guards. Always replace all covers and protective guards before you use the product.
- If you need a new copy of this document because it has been lost or damaged, contact your nearest Yaskawa representative or one of the offices listed on the back of this document.
- This document is subject to change without notice for product improvements, specifications changes, and improvements to the manual itself.
We will update the document number of the document and issue revisions when changes are made.
- Any and all quality guarantees provided by Yaskawa are null and void if the customer modifies the product in any way. Yaskawa disavows any responsibility for damages or losses that are caused by modified products.

Warranty

◆ Details of Warranty

■ Warranty Period

The warranty period for a product that was purchased (hereinafter called the “delivered product”) is one year from the time of delivery to the location specified by the customer or 18 months from the time of shipment from the Yaskawa factory, whichever is sooner.

■ Warranty Scope

Yaskawa shall replace or repair a defective product free of charge if a defect attributable to Yaskawa occurs during the above warranty period.

This warranty does not cover defects caused by the delivered product reaching the end of its service life and replacement of parts that require replacement or that have a limited service life.

This warranty does not cover failures that result from any of the following causes.

- Improper handling, abuse, or use in unsuitable conditions or in environments not described in product catalogs or manuals, or in any separately agreed-upon specifications
- Causes not attributable to the delivered product itself
- Modifications or repairs not performed by Yaskawa
- Use of the delivered product in a manner in which it was not originally intended
- Causes that were not foreseeable with the scientific and technological understanding at the time of shipment from Yaskawa
- Events for which Yaskawa is not responsible, such as natural or human-made disasters

◆ Limitations of Liability

- Yaskawa shall in no event be responsible for any damage or loss of opportunity to the customer that arises due to failure of the delivered product.
- Yaskawa shall not be responsible for any programs (including parameter settings) or the results of program execution of the programs provided by the user or by a third party for use with programmable Yaskawa products.
- The information described in product catalogs or manuals is provided for the purpose of the customer purchasing the appropriate product for the intended application. The use thereof does not guarantee that there are no infringements of intellectual property rights or other proprietary rights of Yaskawa or third parties, nor does it construe a license.
- Yaskawa shall not be responsible for any damage arising from infringements of intellectual property rights or other proprietary rights of third parties as a result of using the information described in catalogs or manuals.

◆ Suitability for Use

- It is the customer's responsibility to confirm conformity with any standards, codes, or regulations that apply if the Yaskawa product is used in combination with any other products.
- The customer must confirm that the Yaskawa product is suitable for the systems, machines, and equipment used by the customer.
- Consult with Yaskawa to determine whether use in the following applications is acceptable. If use in the application is acceptable, use the product with extra allowance in ratings and specifications, and provide safety measures to minimize hazards in the event of failure.
 - Outdoor use, use involving potential chemical contamination or electrical interference, or use in conditions or environments not described in product catalogs or manuals
 - Nuclear energy control systems, combustion systems, railroad systems, aviation systems, vehicle systems, medical equipment, amusement machines, and installations subject to separate industry or government regulations
 - Systems, machines, and equipment that may present a risk to life or property
 - Systems that require a high degree of reliability, such as systems that supply gas, water, or electricity, or systems that operate continuously 24 hours a day
 - Other systems that require a similar high degree of safety
- Never use the product for an application involving serious risk to life or property without first ensuring that the system is designed to secure the required level of safety with risk warnings and redundancy, and that the Yaskawa product is properly rated and installed.
- The circuit examples and other application examples described in product catalogs and manuals are for reference. Check the functionality and safety of the actual devices and equipment to be used before using the product.
- Read and understand all use prohibitions and precautions, and operate the Yaskawa product correctly to prevent accidental harm to third parties.

◆ Specifications Change

The names, specifications, appearance, and accessories of products in product catalogs and manuals may be changed at any time based on improvements and other reasons. The next editions of the revised catalogs or manuals will be published with updated code numbers. Consult with your Yaskawa representative to confirm the actual specifications before purchasing a product.

Compliance with UL Standards, EU Directives, UK Regulations, and Other Safety Standards

Certification marks for the standards for which the product has been certified by certification bodies are shown on nameplate. Products that do not have the marks are not certified for the standards. Refer to the Servomotor manual for compliant standards of Servomotors.

◆ North American Safety Standards (UL)



Product	Model	North American Safety Standards (UL File No.)
SERVOPACK	SGD7S	UL 61800-5-1 (E147823), CSA C22.2 No.274

◆ EU Directives



Product	Model	EU Directive	Harmonized Standards
SERVOPACK	SGD7S	Machinery Directive 2006/42/EC	EN ISO 13849-1: 2015 EN IEC 62061 EN 61800-5-2
		EMC Directive 2014/30/EU	EN 55011 Group 1, Class A EN 61000-6-2 EN 61000-6-4 EN 61800-3 (Category C2, Second environment)
		Low Voltage Directive 2014/35/EU	EN 61800-5-1
		RoHS Directive 2011/65/EU (EU)2015/863	EN IEC 63000

Note: 1. We declared the CE Marking based on the harmonized standards in the above table.

2. These products are for industrial use. In home environments, these products may cause electromagnetic interference and additional noise reduction measures may be necessary.

◆ UK Conformity Assessed (UKCA)



Product	Model	UK Regulations	Designated Standards
SERVOPACK	SGD7S	Supply of Machinery (Safety) Regulations S.I. 2008/1597	EN ISO 13849-1: 2015 EN IEC 62061 EN 61800-5-2
		Electromagnetic Compatibility Regulations S.I. 2016/1091	EN 55011 Group 1, Class A EN 61000-6-2 EN 61000-6-4 EN 61800-3 (Category C2, Second environment)
		Electrical Equipment (Safety) Regulations S.I. 2016/1101	EN 61800-5-1
		Restriction of the Use of Certain Hazardous Substances in Electrical and Electronic Equipment Regulations S.I. 2012/3032	EN IEC 63000

Note: We declared the UKCA marking based on the designated standards in the above table.

◆ Safety Standards

Product	Model	Safety Standards	Standards
SERVOPACK	SGD7S	Safety of Machinery	EN ISO 13849-1:2015 EN 60204-1
		Functional Safety	EN 61508 series EN IEC 62061 EN 61800-5-2
		Functional Safety EMC	EN 61326-3-1 EN 61000-6-7

■ Safety Parameters

Item	Standards	Performance Level	
Safety Integrity Level	EN 61508	SIL3	
	EN IEC 62061	maximum SIL 3	
Mission Time	EN 61508	10 years	20 years
Probability of Dangerous Failure per Hour	EN 61508 EN IEC 62061	PFH = 4.04×10^{-9} [1/h] (4.04% of SIL3)	PFH = 4.05×10^{-9} [1/h] (4.05% of SIL3)
Performance Level	EN ISO 13849-1	PLe (Category 3)	
Mean Time to Dangerous Failure of Each Channel	EN ISO 13849-1	MTTFd: High	
Average Diagnostic Coverage	EN ISO 13849-1	DCavg: Medium	
Stop Category	EN 60204-1	Stop category 0	
Safety Function	EN 61800-5-2	STO	
Hardware Fault Tolerance	EN 61508	HFT = 1	
Subsystem	EN 61508	B	

Contents

About this Manual	iii
Outline of Manual	iii
Related Documents	v
Using This Manual	xii
Safety Precautions	xv
Warranty	xxv
Compliance with UL Standards, EU Directives, UK Regulations, and Other Safety Standards	xxvii

1

Basic Information on SERVOPACKs

1.1	Product Introduction	1-2
1.2	Model Designations	1-3
	1.2.1 Interpreting SERVOPACK Model Numbers	1-3
	1.2.2 Interpreting Direct Drive Servomotor Model Numbers	1-4
1.3	Combinations of SERVOPACKs and Servomotors.	1-5
1.4	Functions	1-6
	1.4.1 SERVOPACK Functions	1-6
	1.4.2 Function Application Restrictions	1-8
1.5	SigmaWin+	1-9
1.6	EtherCAT Communications LED Indicators	1-10
	1.6.1 RUN	1-10
	1.6.2 ERR.	1-11
	1.6.3 Link/Activity.	1-11

2

SERVOPACK Ratings and Specifications

2.1	Ratings	2-2
	2.1.1 Three-Phase, 200 VAC	2-2
	2.1.2 Single-Phase, 200 VAC	2-2
	2.1.3 Single-Phase, 100 VAC	2-3
2.2	SERVOPACK Overload Protection Characteristics	2-4
2.3	Specifications.	2-5

3

Maintenance

3.1	Alarm Displays	3-2
3.1.1	List of Alarms	3-2
3.1.2	Troubleshooting Alarms	3-8
3.2	Warning Displays	3-32
3.2.1	List of Warnings	3-32
3.2.2	Troubleshooting Warnings	3-34
3.3	Troubleshooting Based on the Operation and Conditions of the Servomotor . .	3-39

4

Parameter and Object Lists

4.1	List of Parameters	4-2
4.1.1	Interpreting the Parameter Lists	4-2
4.1.2	List of Parameters	4-3
4.2	Object List	4-26
4.3	SDO Abort Code List	4-34
4.4	Parameter Recording Table	4-35

Index

Revision History

Basic Information on SERVOPACKs

1

This chapter provides basic information, including an introduction to the product, and describes how to interpret model numbers and combinations with Servomotors.

1.1	Product Introduction	1-2
1.2	Model Designations	1-3
1.2.1	Interpreting SERVOPACK Model Numbers	1-3
1.2.2	Interpreting Direct Drive Servomotor Model Numbers	1-4
1.3	Combinations of SERVOPACKs and Servomotors ..	1-5
1.4	Functions	1-6
1.4.1	SERVOPACK Functions	1-6
1.4.2	Function Application Restrictions	1-8
1.5	SigmaWin+	1-9
1.6	EtherCAT Communications LED Indicators ..	1-10
1.6.1	RUN	1-10
1.6.2	ERR	1-11
1.6.3	Link/Activity	1-11

1.1 Product Introduction

The SERVOPACKs described in this manual were developed to drive SGM7D motors.

The SGM7D motors were designed for applications that require high torque, easy operation, and high precision. The SERVOPACK will make the most of machine performance in the shortest time possible, thus contributing to improving productivity.

1.2 Model Designations

1.2.1 Interpreting SERVOPACK Model Numbers



1st+2nd+3rd digits Maximum Applicable Motor Capacity

Voltage	Code	Specification
Three-Phase, 200 VAC	2R8*1	0.4 kW
	120*2	1.5 kW
Single-Phase, 100 VAC	2R8	0.4 kW

4th digit Voltage

Code	Specification
A	200 VAC
F	100 VAC

5th+6th digits Interface

Code	Specification
A0	EtherCAT communications reference

7th digit Design Revision Order

A

8th+9th+10th digits Hardware Options Specification

Code	Specification	Applicable Models
000	Without options	All models
001	Rack-mounted	All models
002	Varnished	All models
008	Single-phase, 200-VAC power supply input	SGD7S-120A
020*3	No dynamic brake	SGD7S-2R8A and -2R8F
	External dynamic brake resistor	SGD7S-120A

11th+12th+13th digits FT/EX Specification

Code	Specification
F82	Application function option for special motors, SGM7D motor drive

- *1. You can use these models with either a single-phase or three-phase input.
- *2. A model with a single-phase, 200-VAC power supply input is available as a hardware option (model: SGD7S-120A00A008).
- *3. Refer to the following manual for details.
📖 Σ-7-Series Σ-7S/Σ-7W SERVOPACK with Dynamic Brake Hardware Option Specifications Product Manual (Manual No.: SIEP S800001 73)

1.2.2 Interpreting Direct Drive Servomotor Model Numbers

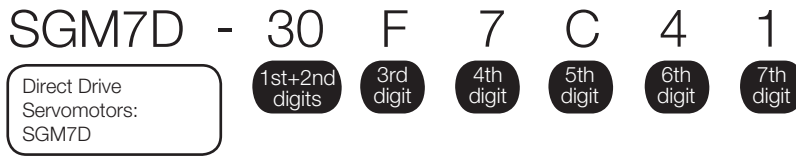

1st+2nd digits Rated Torque

Code	Specification	Code	Specification	Code	Specification
01	1.30 N·m	18	18.0 N·m	58	58.0 N·m
02	2.06 N·m	20	20.0 N·m	70	70.0 N·m
03	3.00 N·m	24	24.0 N·m	90	90.0 N·m
05	5.00 N·m	28	28.0 N·m	1Z	100 N·m
06	6.00 N·m	30	30.0 N·m	1A	110 N·m
08	8.00 N·m	34	34.0 N·m	1C	130 N·m
09	9.00 N·m	38	38.0 N·m	2B	220 N·m
12	12.0 N·m	45	45.0 N·m	2D	240 N·m

3rd digit Servomotor Outer Diameter

Code	Specification	Code	Specification
F	264-mm dia.	J	150-mm dia.
G	160-mm dia.	K	107-mm dia.
H	116-mm dia.	L	224 mm × 224 mm
I	264-mm dia.		

Note: 1. Direct Drive Servomotors are not available with holding brakes.
 2. This information is provided to explain model numbers. It is not meant to imply that models are available for all combinations of codes.

4th digit Serial Encoder

Code	Specification
7	24-bit multiturn absolute encoder
F	24-bit incremental encoder

5th digit Design Revision Order

C

6th digit Flange

Code	Mounting	Servomotor Outer Diameter Code (3rd Digit)						
		F	G	H	I	J	K	L
4	Non-load side With cable on side	✓	✓	✓	-	-	-	✓
5	Non-load side With cable on bottom	✓	✓*	-	✓	✓	✓	-

✓: Applicable models.

* SGM7D-01G and -05G are not available with a cable extending from the bottom.

7th digit Options

Code	Specification
1	Standard mechanical precision
2	High mechanical precision*

* The SGM7D-01G, -05G, and -03H are available only with high mechanical precision.

◆ Manufactured Models

Rated Torque N·m	Servomotor Outer Diameter						
	F (264-mm dia.)	G (160-mm dia.)	H (116-mm dia.)	I (264-mm dia.)	J (150-mm dia.)	K (107-mm dia.)	L (224 mm × 224 mm)
1.30	-	SGM7D-01G	-	-	-	-	-
2.06	-	-	-	-	-	SGM7D-02K	-
3.00	-	-	SGM7D-03H	-	-	-	-
5.00	-	SGM7D-05G	-	-	-	-	-
6.00	-	-	-	-	SGM7D-06J	SGM7D-06K	SGM7D-06L
8.00	-	SGM7D-08G	-	-	-	SGM7D-08K	-
9.00	-	-	-	-	SGM7D-09J	-	-
12.0	-	-	-	-	-	-	SGM7D-12L
18.0	-	SGM7D-18G	-	-	SGM7D-18J	-	-
20.0	-	-	-	-	SGM7D-20J	-	-
24.0	-	SGM7D-24G	-	-	-	-	-
28.0	-	-	-	SGM7D-28I	-	-	-
30.0	SGM7D-30F	-	-	-	-	-	SGM7D-30L
34.0	-	SGM7D-34G	-	-	-	-	-
38.0	-	-	-	-	SGM7D-38J	-	-
45.0	-	SGM7D-45G	-	-	-	-	-
58.0	SGM7D-58F	-	-	-	-	-	-
70.0	-	-	-	SGM7D-70I	-	-	-
90.0	SGM7D-90F	-	-	-	-	-	-
100	-	-	-	SGM7D-1Z	-	-	-
110	SGM7D-1AF	-	-	-	-	-	-
130	-	-	-	SGM7D-1CI	-	-	-
220	-	-	-	SGM7D-2BI	-	-	-
240	-	-	-	SGM7D-2DI	-	-	-

Note: The above table shows combinations of the rated torque and outer diameter. The fourth through seventh digits have been omitted.

1.3

Combinations of SERVOPACKs and Servomotors

Direct Drive Servomotor Model	Capacity	SERVOPACK Model
		SGD7S-
SGM7D-30F	188 W	120A
SGM7D-58F	364 W	
SGM7D-90F	565 W	
SGM7D-1AF	691 W	
SGM7D-01G	16 W	2R8A and 2R8F
SGM7D-05G	63 W	
SGM7D-08G	101 W	120A
SGM7D-18G	226 W	
SGM7D-24G	302 W	
SGM7D-34G	320 W	
SGM7D-45G	565 W	
SGM7D-03H	38 W	2R8A and 2R8F
SGM7D-28I	264 W	120A
SGM7D-70I	440 W	
SGM7D-1ZI	628 W	
SGM7D-1CI	817 W	
SGM7D-2BI	691 W	
SGM7D-2DI	754 W	
SGM7D-06J	75 W	
SGM7D-09J	113 W	
SGM7D-18J	226 W	
SGM7D-20J	251 W	
SGM7D-38J	358 W	2R8A and 2R8F
SGM7D-02K	52 W	
SGM7D-06K	151 W	
SGM7D-08K	201 W	
SGM7D-06L	113 W	120A
SGM7D-12L	226 W	
SGM7D-30L	565 W	

1.4 Functions

This section lists the functions provided by SERVOPACKs. Refer to the following manuals for details on the functions.
 ④ Σ -7-Series Σ -7S SERVOPACK with EtherCAT (CoE) Communications References Product Manual (Manual No.: SIEP S800001 55)
 Functions in bold boxes in the functions tables are restricted if the above SERVOPACKs are used. Refer to the following section for details on restrictions to these functions.

📖 1.4.2 Function Application Restrictions on page 1-8

1.4.1 SERVOPACK Functions

• Functions Related to the Machine

Functions
Power Supply Type Settings for the Main Circuit and Control Circuit
Automatic Detection of Connected Motor
Motor Direction Setting
Setting the Linear Encoder Pitch
Writing Linear Servomotor Parameters
Selecting the Phase Sequence for a Linear Servomotor
Polarity Sensor Setting
Polarity Detection
Overtravel Function and Settings
Holding Brake
Motor Stopping Method for Servo OFF and Alarms
Resetting the Absolute Encoder
Setting the Origin of the Absolute Encoder
Setting the Regenerative Resistor Capacity
Operation for Momentary Power Interruptions
SEMI F47 Function
Motor Maximum Speed Setting
Software Limits
Multiturn Limit Setting
Adjustment of Motor Current Detection Signal Offset
Forcing the Motor to Stop
Overheat Protection
Speed Ripple Compensation
Current Control Mode Selection
Current Gain Level Setting
Speed Detection Method Selection
Fully-closed Loop Control
Safety Function

• Functions Related to the Host Controller

Function
Electronic Gear Settings
I/O Signal Allocations
ALM (Servo Alarm) Signal
/WARN (Warning) Signal
/TGON (Rotation Detection) Signal
/S-RDY (Servo Ready) Signal
/V-CMP (Speed Coincidence Detection) Signal
/COIN (Positioning Completion) Signal

Continued on next page.

Continued from previous page.

Function
/NEAR (Near) Signal
Speed Limit during Torque Control
/VLT (Speed Limit Detection) Signal
Encoder Divided Pulse Output
Selecting Torque Limits
Vibration Detection Level Initialization
Alarm Reset
Replacing the Battery
Setting the Position Deviation Overflow Alarm Level

- **Functions to Achieve Optimum Motions**

Function
Tuning-less Function
Autotuning without a Host Reference
Autotuning with a Host Reference
Custom Tuning
Anti-Resonance Control Adjustment
Vibration Suppression
Gain Selection
Friction Compensation
Gravity Compensation
Backlash Compensation
Model Following Control
Compatible Adjustment Functions
Mechanical Analysis
Easy FFT

- **Functions for Trial Operation during Setup**

Function
Software Reset
Trial Operation for the Servomotor without a Load
Program Jogging
Origin Search
Test without a Motor
Monitoring Machine Operation Status and Signal Waveforms

- **Functions for Inspection and Maintenance**

Function
Write Prohibition Setting for Parameters
Initializing Parameter Settings
Automatic Detection of Connected Motor
Monitoring Product Information
Monitoring Product Life
Alarm History Display
Alarm Tracing

1.4.2 Function Application Restrictions

The following functional restrictions apply when you use the SERVOPACKs.

Function	Restriction
Setting the Linear Encoder Pitch	Cannot be used.
Writing Linear Servomotor Parameters	Cannot be used.
Selecting the Phase Sequence for a Linear Servomotor	Cannot be used.
Polarity Sensor Setting	Cannot be used.
Polarity Detection	Cannot be used.
Speed Ripple Compensation	Cannot be used. Do not change the following default setting: Pn423 = n.□□□0.
Tuning-less Function	Cannot be used if the load moment of inertia ratio is 10 or greater.

1.5 SigmaWin+

To use the SigmaWin+, a model information file for the SERVOPACK must be added to SigmaWin+ version 7.

1.6 EtherCAT Communications LED Indicators

This diagram shows details of the EtherCAT communications LED indicators.

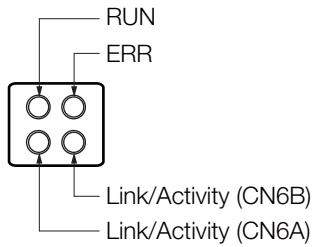

1.6.1 RUN

The RUN indicator shows the status of EtherCAT communications.

Status	LED Indicator		Description
	Pattern		
Off	Constantly off.		EtherCAT communications are in INIT state.
Blinking			EtherCAT communications are in PRE-OPERATIONAL state.
Single flash			EtherCAT communications are in SAFE-OPERATIONAL state.
On	Constantly on.		EtherCAT communications are in OPERATIONAL state.
Flickering			EtherCAT communications have been started but are not yet in INIT state.

1.6.2 ERR

The ERR indicator shows the error status of EtherCAT communications.

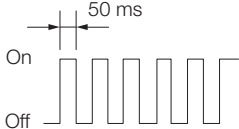
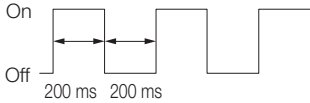
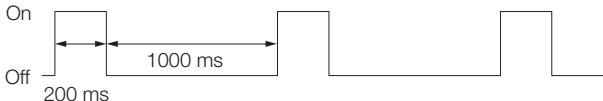
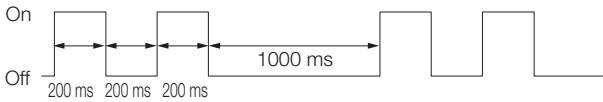
LED Indicator		Description
Status	Pattern	
Off	Constantly off.	The EtherCAT communications are in working condition.
Flickering		Booting Error was detected.
Blinking		State change commanded by MDevice is impossible due to register or object settings.
Single flash		Synchronization Error, the EtherCAT Network Module enters SAFE-OPERATIONAL state automatically.
Double flash		An application (Sync Manager) watchdog timeout has occurred.
On	Constantly on.	A PDI Watchdog timeout has occurred.

1.6.3 Link/Activity

The Link/Activity indicators show whether Communications Cables are connected to the CN6A and CN6B connectors and whether communications are active.

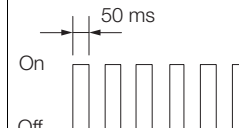
LED Indicator		Description
Status	Pattern	
Off	Constantly off.	A Communications Cable is not physically connected. A EtherCAT controller is not started up.
Flickering		Data are being exchanged.
On	Constantly on.	A Communications Cable is physically connected, but no data being exchanged.

SERVOPACK Ratings and Specifications

2

This chapter provides information required to select SERVOPACKs, such as specifications.

2.1	Ratings	2-2
2.1.1	Three-Phase, 200 VAC	2-2
2.1.2	Single-Phase, 200 VAC	2-2
2.1.3	Single-Phase, 100 VAC	2-3
2.2	SERVOPACK Overload Protection Characteristics ..	2-4
2.3	Specifications	2-5

2.1 Ratings

This section gives the ratings of SERVOPACKs.

2.1.1 Three-Phase, 200 VAC

Model SGD7S-			2R8A	120A
Maximum Applicable Motor Capacity [kW]			0.4	1.5
Continuous Output Current [Arms]			2.8	11.6
Instantaneous Maximum Output Current [Arms]			9.3	28
Main Circuit	Power Supply		200 VAC to 240 VAC, 50 Hz/60 Hz	
	Permitted Voltage Fluctuation		-15% to +10%	
	Input Current [Arms]*		2.5	7.3
Control	Power Supply		200 VAC to 240 VAC, 50 Hz/60 Hz	
	Permitted Voltage Fluctuation		-15% to +10%	
	Input Current [Arms]*		0.2	0.2
Power Supply Capacity [kVA]*			1.0	3.2
Power Loss*	Main Circuit Power Loss [W]		22.5	72.6
	Control Circuit Power Loss [W]		12	15
	Built-in Regenerative Resistor Power Loss [W]		–	12
	Total Power Loss [W]		34.5	97.6
Regenerative Resistor	Built-In Regenerative Resistor	Resistance [Ω]	–	20
		Capacity [W]	–	60
	Minimum Allowable External Resistance [Ω]		40	20
Overvoltage Category			III	

* This is the net value at the rated load.

2.1.2 Single-Phase, 200 VAC

Model SGD7S-			2R8A	120A
Maximum Applicable Motor Capacity [kW]			0.4	1.5
Continuous Output Current [Arms]			2.8	11.6
Instantaneous Maximum Output Current [Arms]			9.3	28
Main Circuit	Power Supply		200 VAC to 240 VAC, 50 Hz/60 Hz	
	Permitted Voltage Fluctuation		-15% to +10%	
	Input Current [Arms]*		5.0	16
Control	Power Supply		200 VAC to 240 VAC, 50 Hz/60 Hz	
	Permitted Voltage Fluctuation		-15% to +10%	
	Input Current [Arms]*		0.2	0.25
Power Supply Capacity [kVA]*			1.2	4.0
Power Loss*	Main Circuit Power Loss [W]		23.7	71.8
	Control Circuit Power Loss [W]		12	16
	Built-in Regenerative Resistor Power Loss [W]		–	12
	Total Power Loss [W]		35.7	103.8
Regenerative Resistor	Built-In Regenerative Resistor	Resistance [Ω]	–	12
		Capacity [W]	–	60
	Minimum Allowable External Resistance [Ω]		40	12
Overvoltage Category			III	

* This is the net value at the rated load.

2.1.3 Single-Phase, 100 VAC

SGD7S-		2R8F
Maximum Applicable Motor Capacity [kW]		0.4
Continuous Output Current [Arms]		2.8
Instantaneous Maximum Output Current [Arms]		9.3
Main Circuit	Power Supply	100 VAC to 120 VAC, 50 Hz/60 Hz
	Permitted Voltage Fluctuation	-15% to +10%
	Input Current [Arms]*	10
Control	Power Supply	100 VAC to 120 VAC, 50 Hz/60 Hz
	Permitted Voltage Fluctuation	-15% to +10%
	Input Current [Arms]*	0.38
Power Supply Capacity [kVA]*		1.4
Power Loss*	Main Circuit Power Loss [W]	26.2
	Control Circuit Power Loss [W]	12
	Total Power Loss [W]	38.2
Regenerative Resistor	Minimum Allowable Resistance [Ω]	40
Overvoltage Category		III

* This is the net value at the rated load.

2.2

SERVOPACK Overload Protection Characteristics

The overload protection characteristics of the SERVOPACKs are the same as the standard Σ -7-Series SERVOPACKs. Refer to the following manual for details.

 Σ -7-Series Σ -7S SERVOPACK with EtherCAT (CoE) Communications References Product Manual
(Manual No.: SIEP S800001 55)

2.3 Specifications

The product specifications are given below.

Item		Specification						
Control Method		IGBT-based PWM control, sine wave current drive						
Feedback		Serial encoder: 24 bits (Incremental encoder/absolute encoder)						
Environmental Conditions	Surrounding Air Temperature* ¹	-5°C to 55°C (With derating, usage is possible between 55°C and 60°C.) Refer to the following manual for derating specifications. 📖 Σ -7-Series Σ -7S SERVOPACK with EtherCAT (CoE) Communications References Product Manual (Manual No.: SIEP S800001 55)						
	Storage Temperature	-20°C to 85°C						
	Surrounding Air Humidity	95% relative humidity max. (with no freezing or condensation)						
	Storage Humidity	95% relative humidity max. (with no freezing or condensation)						
	Vibration Resistance	4.9 m/s ²						
	Shock Resistance	19.6 m/s ²						
	Degree of Protection	<table border="1"> <thead> <tr> <th>Degree</th> <th>SERVOPACK Model: SGD7S-</th> </tr> </thead> <tbody> <tr> <td>IP20</td> <td>2R8A, 120A (Three-phase, 200VAC input), 2R8F</td> </tr> <tr> <td>IP10</td> <td>120A00A008 (Single-phase, 200VAC)</td> </tr> </tbody> </table>	Degree	SERVOPACK Model: SGD7S-	IP20	2R8A, 120A (Three-phase, 200VAC input), 2R8F	IP10	120A00A008 (Single-phase, 200VAC)
	Degree	SERVOPACK Model: SGD7S-						
	IP20	2R8A, 120A (Three-phase, 200VAC input), 2R8F						
IP10	120A00A008 (Single-phase, 200VAC)							
Pollution Degree	2 <ul style="list-style-type: none"> • Must be no corrosive or flammable gases. • Must be no exposure to water, oil, or chemicals. • Must be no dust, salts, or iron dust. 							
Altitude* ¹	1,000 m max. (With derating, usage is possible between 1,000 m and 2,000 m.) Refer to the following manual for derating specifications. 📖 Σ -7-Series Σ -7S SERVOPACK with EtherCAT (CoE) Communications References Product Manual (Manual No.: SIEP S800001 55)							
Others	Do not use the SERVOPACK in the following locations: Locations subject to static electricity, noise, strong electromagnetic/magnetic fields, or radioactivity							
Compliant Standards		Refer to the following section for details. 📖 <i>Compliance with UL Standards, EU Directives, UK Regulations, and Other Safety Standards on page xxvii</i>						
Mounting		Base-mounted						
Performance	Speed Control Range	1:5000 (At the rated torque, the lower limit of the speed control range must not cause the Servomotor to stop.)						
	Coefficient of Speed Fluctuation* ²	±0.01% of rated speed max. (for a load fluctuation of 0% to 100%)						
		0% of rated speed max. (for a load fluctuation of ±10%)						
	Torque Control Precision (Repeatability)	±1%						
Soft Start Time Setting	0 s to 10 s (Can be set separately for acceleration and deceleration.)							

Continued on next page.

Continued from previous page.

Item		Specification	
I/O Signals	Encoder Divided Pulse Output	Phase A, phase B, phase C: Line-driver output Number of divided output pulses: Any setting is allowed.	
	Sequence Input Signals	Input Signals That Can Be Allocated	Allowable voltage range: 24 VDC \pm 20% Number of input points: 7 (Input method: Sink inputs or source inputs)
			Input Signals <ul style="list-style-type: none"> • P-OT (Forward Drive Prohibit) and N-OT (Reverse Drive Prohibit) signals • /Probe1 (Probe 1 Latch Input) signal • /Probe2 (Probe 2 Latch Input) signal • /Home (Home Switch Input) signal • /P-CL (Forward External Torque Limit) and /N-CL (Reverse External Torque Limit) signals • FSTP (Forced Stop Input) signal A signal can be allocated and the positive and negative logic can be changed.
	Sequence Output Signals	Fixed Output	Allowable voltage range: 5 VDC to 30 VDC Number of output points: 1 (A photocoupler output (isolated) is used.) Output signal: ALM (Servo Alarm) signal
		Output Signals That Can Be Allocated	Allowable voltage range: 5 VDC to 30 VDC Number of output points: 3 (A photocoupler output (isolated) is used.) Output Signals <ul style="list-style-type: none"> • /COIN (Positioning Completion) signal • /V-CMP (Speed Coincidence Detection) signal • /TGON (Rotation Detection) signal • /S-RDY (Servo Ready) signal • /CLT (Torque Limit Detection) signal • /VLT (Speed Limit Detection) signal • /BK (Brake) signal • /WARN (Warning) signal • /NEAR (Near) signal A signal can be allocated and the positive and negative logic can be changed.
	Communications	RS-422A Communications (CN502)	Inter- faces
1:N Commu- nications			Up to N = 15 stations possible for RS-422A port
Axis Address Setting			Set with parameters.
USB Communications (CN7)		Interface	Personal computer (with SigmaWin+)
	Commu- nications Standard	Conforms to USB2.0 standard (12 Mbps).	
Displays/Indicators		CHARGE, PWR, CN, RUN, ERR, and L/A (A and B) indicators, and one-digit seven-segment display	
EtherCAT Communications Setting Switches		EtherCAT secondary address (S1 and S2), 16 positions	

Continued on next page.

Continued from previous page.

Item		Specification
EtherCAT Communi- cations	Compliant Communi- cations Standards	IEC 61158 Type 12, IEC 61800-7 CiA402 Drive Profile
	Physical Layer	100BASE-TX (IEEE 802.3)
	Communications Connectors	CN6A (RJ45): ETHERCAT IN (EtherCAT signal input connector) CN6B (RJ45): ETHERCAT OUT (EtherCAT signal output connector)
	Cable	Category 5, 4 shielded twisted pairs The cable is automatically detected with AUTO MDIX.
	Sync Manager	SM0: Mailbox output, SM1: Mailbox input, SM2: Process data output, and SM3: Process data input
	FMMU	FMMU 0: Mapped in process data output (RxPDO) area. FMMU 1: Mapped in process data input (TxPDO) area. FMMU 2: Mapped to mailbox status.
	EtherCAT Commands (Data Link Layer)	APRD, FPRD, BRD, LRD, APWR, FPWR, BWR, LWR, ARMW, and FRMW (APRW, FPRW, BRW, and LRW commands are not supported.)
	Process Data	Assignments can be changed with PDO mapping.
	Mailbox (CoE)	Emergency messages, SDO requests, SDO responses, and SDO infor- mation (TxPDO/RxPDO and remote TxPDO/RxPDO are not supported.)
	Distributed Clocks	Free-Run Mode and DC Mode (Can be switched.) Applicable DC cycles: 125 μ s to 4 ms in 125- μ s increments
	SubDevice Informa- tion IF	256 bytes (read-only)
	Indicators	EtherCAT communications in progress: Link/Activity x 2 EtherCAT communications status: RUN x 1 EtherCAT error status: ERR x 1
CiA402 Drive Profile	<ul style="list-style-type: none"> • Homing Mode • Profile Position Mode • Interpolated Position Mode • Profile Velocity Mode • Profile Torque Mode • Cyclic Synchronous Position Mode • Cyclic Synchronous Velocity Mode • Cyclic Synchronous Torque Mode • Touch Probe Function • Torque Limit Function 	
Analog Monitor (CN5)	Number of points: 2 Output voltage range: ± 10 VDC (effective linearity range: ± 8 V) Resolution: 16 bits Accuracy: ± 20 mV (Typ) Maximum output current: ± 10 mA Settling time ($\pm 1\%$): 1.2 ms (Typ)	
Dynamic Brake (DB)	Activated when a servo alarm or overtravel (OT) occurs, or when the power supply to the main circuit or servo is OFF.	
Regenerative Processing	Built-in Refer to the following catalog for details.  AC Servo Drives Σ -7-Series (Manual No.: KAEP S800001 23)	
Overtravel (OT) Prevention	Stopping with dynamic brake, deceleration to a stop, or coasting to a stop for the P-OT (Forward Drive Prohibit) or N-OT (Reverse Drive Pro- hibit) signal	
Protective Functions	Overcurrent, overvoltage, low voltage, overload, regeneration error, etc.	
Utility Functions	Gain adjustment, alarm history, jogging, origin search, etc.	
Safety Functions	Inputs	/HWBB1 and /HWBB2: Base block signals for Power Modules
	Output	EDM1: Monitors the status of built-in safety circuit (fixed output).
	Compliant Standards* ³	ISO13849-1 PLe (Category 3), IEC61508 SIL3
Applicable Option Modules	Fully-Closed Modules	

2.3 Specifications

- *1. If you combine a Σ -7-Series SERVOPACK with a Σ -V-Series Option Module, the following Σ -V-Series SERVOPACKs specifications must be used: a surrounding air temperature of 0°C to 55°C and an altitude of 1,000 m max. Also, the applicable surrounding range cannot be increased by derating.
- *2. The coefficient of speed fluctuation for load fluctuation is defined as follows:
Coefficient of speed fluctuation = $\frac{\text{No-load motor speed} - \text{Total-load motor speed}}{\text{Rated motor speed}} \times 100\%$
- *3. Always perform risk assessment for the system and confirm that the safety requirements are met.

Maintenance



This chapter provides information on the meaning of, causes of, and corrections for alarms and warnings. In this chapter, the object index number (2□□□h) for EtherCAT communications is given after the SERVOPACK parameter number (Pn□□□).

3.1	Alarm Displays	3-2
3.1.1	List of Alarms	3-2
3.1.2	Troubleshooting Alarms	3-8
3.2	Warning Displays	3-32
3.2.1	List of Warnings	3-32
3.2.2	Troubleshooting Warnings	3-34
3.3	Troubleshooting Based on the Operation and Conditions of the Servomotor . .	3-39

3.1 Alarm Displays

To check an alarm that occurs in the SERVOPACK, use one of the following methods. However, if no alarm number appears on the panel display, this indicates a SERVOPACK system error. Replace the SERVOPACK.

Panel display on SERVOPACK	<p>If there is an alarm, the code will be displayed one character at a time, as shown below. Example: Alarm A.020</p>
Digital Operator	The alarm code will be displayed.
Statusword (6041h)	Bit 3 (<i>fault</i>) in the <i>statusword</i> will change to 1. (Bit 3 is 0 during normal operation.)
Error Code (603Fh)	A current alarm code is stored in object 603Fh.
Emergency message	The Controller is notified of any alarm that occurs. (Notification may not be possible if EtherCAT communications are unstable.)

This section provides a list of the alarms that may occur and the causes of and corrections for those alarms.

3.1.1 List of Alarms

The following alarm tables gives the alarm name, alarm meaning, alarm stopping method, and alarm reset possibility in order of the alarm codes.

Servomotor Stopping Method for Alarms

Refer to the following manual for information on the Servomotor stopping method for alarms.

Σ-7-Series Σ-7S SERVOPACK with EtherCAT (CoE) Communications References Product Manual (Manual No.: SIEP S800001 55)

Alarm Reset Possibility

Yes: You can use an alarm reset to clear the alarm. However, this assumes that the cause of the alarm has been removed.

No: You cannot clear the alarm.

List of Alarms

Alarm Code	Alarm Name	Alarm Meaning	Servo-motor Stopping Method	Alarm Reset Possi-ble?
020h	Parameter Checksum Error	There is an error in the parameter data in the SERVOPACK.	Gr.1	No
021h	Parameter Format Error	There is an error in the parameter data format in the SERVOPACK.	Gr.1	No
022h	System Checksum Error	There is an error in the parameter data in the SERVOPACK.	Gr.1	No
024h	System Alarm	An internal program error occurred in the SERVOPACK.	Gr.1	No
025h	System Alarm	An internal program error occurred in the SERVOPACK.	Gr.1	No

Continued on next page.

Continued from previous page.

Alarm Code	Alarm Name	Alarm Meaning	Servo-motor Stopping Method	Alarm Reset Possible?
030h	Main Circuit Detector Error	There is an error in the detection data for the main circuit.	Gr.1	Yes
040h	Parameter Setting Error	A parameter setting is outside of the setting range.	Gr.1	No
041h	Encoder Output Pulse Setting Error	The setting of Pn212 (2212h) (Encoder Output Pulses) or Pn281 (2281h) (Encoder Output Resolution) is outside of the setting range or does not satisfy the setting conditions.	Gr.1	No
042h	Parameter Combination Error	The combination of some parameters exceeds the setting range.	Gr.1	No
044h	Semi-Closed/Fully-Closed Loop Control Parameter Setting Error	The settings of the Option Module and Pn002 = n.X□□□ (External Encoder Usage) do not match.	Gr.1	No
050h	Combination Error	The capacities of the SERVOPACK and Servomotor do not match.	Gr.1	Yes
051h	Unsupported Device Alarm	An unsupported device was connected.	Gr.1	No
070h	Motor Type Change Detected	The connected motor is a different type of motor from the previously connected motor.	Gr.1	No
0b0h	Invalid Servo ON Command Alarm	The Servo ON command (Enable Operation command) was sent from the host controller after a utility function that turns ON the Servomotor was executed.	Gr.1	Yes
100h	Overcurrent Detected	An overcurrent flowed through the power transformer or the heat sink overheated.	Gr.1	No
101h	Motor Overcurrent Detected	The current to the motor exceeded the allowable current.	Gr.1	No
300h	Regeneration Error	There is an error related to regeneration.	Gr.1	Yes
320h	Regenerative Overload	A regenerative overload occurred.	Gr.2	Yes
330h	Main Circuit Power Supply Wiring Error	<ul style="list-style-type: none"> The AC power supply input setting or DC power supply input setting is not correct. The power supply wiring is not correct. 	Gr.1	Yes
400h	Overvoltage	The main circuit DC voltage is too high.	Gr.1	Yes
410h	Undervoltage	The main circuit DC voltage is too low.	Gr.2	Yes
510h	Overspeed	The motor exceeded the maximum speed.	Gr.1	Yes
511h	Encoder Output Pulse Overspeed	The pulse output speed for the setting of Pn212 (2212h) (Number of Encoder Output Pulses) was exceeded.	Gr.1	Yes
520h	Vibration Alarm	Abnormal oscillation was detected in the motor speed.	Gr.1	Yes
521h	Autotuning Alarm	Vibration was detected during autotuning for the tuning-less function.	Gr.1	Yes
550h	Maximum Speed Setting Error	The setting of Pn385 (2385h) (Maximum Motor Speed) is greater than the maximum motor speed.	Gr.1	Yes
710h	Instantaneous Overload	The Servomotor was operating for several seconds to several tens of seconds under a torque that largely exceeded the rating.	Gr.2	Yes
720h	Continuous Overload	The Servomotor was operating continuously under a torque that exceeded the rating.	Gr.1	Yes
730h	Dynamic Brake Overload	When the dynamic brake was applied, the rotational or linear kinetic energy exceeded the capacity of the dynamic brake resistor.	Gr.1	Yes
731h				

Continued on next page.

3.1 Alarm Displays

3.1.1 List of Alarms

Continued from previous page.

Alarm Code	Alarm Name	Alarm Meaning	Servo-motor Stopping Method	Alarm Reset Possible?
740h	Inrush Current Limiting Resistor Overload	The main circuit power supply was frequently turned ON and OFF.	Gr.1	Yes
7A1h	Internal Temperature Error 1 (Control Board Temperature Error)	The surrounding temperature of the control PCB is abnormal.	Gr.2	Yes
7A2h	Internal Temperature Error 2 (Power Board Temperature Error)	The surrounding temperature of the power PCB is abnormal.	Gr.2	Yes
7A3h	Internal Temperature Sensor Error	An error occurred in the temperature sensor circuit.	Gr.2	No
7Abh	SERVOPACK Built-in Fan Stopped	The fan inside the SERVOPACK stopped.	Gr.1	Yes
810h	Encoder Backup Alarm	The power supplies to the encoder all failed and the position data was lost.	Gr.1	No
820h	Encoder Checksum Alarm	There is an error in the checksum results for encoder memory.	Gr.1	No
830h	Encoder Battery Alarm	The battery voltage was lower than the specified level after the control power supply was turned ON.	Gr.1	Yes
840h	Encoder Data Alarm	There is an internal data error in the encoder.	Gr.1	No
850h	Encoder Overspeed	The encoder was operating at high speed when the power was turned ON.	Gr.1	No
860h	Encoder Overheated	The internal temperature of encoder is too high.	Gr.1	No
8A0h	External Encoder Error	An error occurred in the external encoder.	Gr.1	Yes
8A1h	External Encoder Module Error	An error occurred in the Serial Converter Unit.	Gr.1	Yes
8A2h	External Incremental Encoder Sensor Error	An error occurred in the external encoder.	Gr.1	Yes
8A3h	External Absolute Encoder Position Error	An error occurred in the position data of the external encoder.	Gr.1	Yes
8A5h	External Encoder Overspeed	An overspeed error occurred in the external encoder.	Gr.1	Yes
8A6h	External Encoder Overheated	An overheating error occurred in the external encoder.	Gr.1	Yes
A10h	EtherCAT DC Synchronization Error *1	The SERVOPACK and Sync0 events cannot be synchronized.	Gr.2*2	Yes
A11h	EtherCAT State Error	The EtherCAT AL does not move to the Operational state when the DS402 drive is in Operation Enabled state.	Gr.2*2	Yes
A12h	EtherCAT Outputs Data Synchronization Error *1	The process data reception events and Sync0 events cannot be synchronized. (Process data communications failed.)	Gr.2	Yes
A20h	Parameter Setting Error	A parameter setting exceeds the setting range.	Gr.1	No
A40h	System Initialization Error	Initialization failed when the power supply was turned ON.	Gr.1	No
A41h	Communication Device Initialization Error	An error occurred during ESC initialization.	Gr.1	No
A47h	Loading Servo Information Error	Loading SERVOPACK information failed.	Gr.1	No
A48h	EEPROM Parameter Data Error	A checksum error occurred in the EEPROM.	Gr.1	No
b33h	Current Detection Error 3	An error occurred in the current detection circuit.	Gr.1	No

Continued on next page.

Continued from previous page.

Alarm Code	Alarm Name	Alarm Meaning	Servo-motor Stopping Method	Alarm Reset Possible?
bF0h	System Alarm 0	Internal program error 0 occurred in the SERVO-PACK.	Gr.1	No
bF1h	System Alarm 1	Internal program error 1 occurred in the SERVO-PACK.	Gr.1	No
bF2h	System Alarm 2	Internal program error 2 occurred in the SERVO-PACK.	Gr.1	No
bF3h	System Alarm 3	Internal program error 3 occurred in the SERVO-PACK.	Gr.1	No
bF4h	System Alarm 4	Internal program error 4 occurred in the SERVO-PACK.	Gr.1	No
bF5h	System Alarm 5	Internal program error 5 occurred in the SERVO-PACK.	Gr.1	No
bF6h	System Alarm 6	Internal program error 6 occurred in the SERVO-PACK.	Gr.1	No
bF7h	System Alarm 7	Internal program error 7 occurred in the SERVO-PACK.	Gr.1	No
bF8h	System Alarm 8	Internal program error 8 occurred in the SERVO-PACK.	Gr.1	No
C10h	Servomotor Out of Control	The Servomotor ran out of control.	Gr.1	Yes
C80h	Encoder Clear Error or Multiturn Limit Setting Error	The multiturn data for the absolute encoder was not correctly cleared or set.	Gr.1	No
C90h	Encoder Communications Error	Communications between the encoder and SERVO-PACK is not possible.	Gr.1	No
C91h	Encoder Communications Position Data Acceleration Rate Error	An error occurred in calculating the position data of the encoder.	Gr.1	No
C92h	Encoder Communications Timer Error	An error occurred in the communications timer between the encoder and SERVOPACK.	Gr.1	No
CA0h	Encoder Parameter Error	The parameters in the encoder are corrupted.	Gr.1	No
Cb0h	Encoder Echoback Error	The contents of communications with the encoder are incorrect.	Gr.1	No
CC0h	Multiturn Limit Disagreement	Different multiturn limits have been set in the encoder and the SERVOPACK.	Gr.1	No
CF1h	Reception Failed Error in Feedback Option Module Communications	Receiving data from the Feedback Option Module failed.	Gr.1	No
CF2h	Timer Stopped Error in Feedback Option Module Communications	An error occurred in the timer for communications with the Feedback Option Module.	Gr.1	No
d00h	Position Deviation Overflow	The setting of Pn520 (2520h) (Excessive Position Deviation Alarm Level) was exceeded by the position deviation.	Gr.1	Yes
d01h	Position Deviation Overflow Alarm at Servo ON	The servo was turned ON after the position deviation exceeded the setting of Pn526 (2526h) (Excessive Position Deviation Alarm Level at Servo ON) while the servo was OFF.	Gr.1	Yes

Continued on next page.

3.1 Alarm Displays

3.1.1 List of Alarms

Continued from previous page.

Alarm Code	Alarm Name	Alarm Meaning	Servo-motor Stopping Method	Alarm Reset Possible?
d02h	Position Deviation Overflow Alarm for Speed Limit at Servo ON	If position deviation remains in the deviation counter, the setting of Pn529 (2529h) or Pn584 (2584h) (Speed Limit Level at Servo ON) will limit the speed when the servo is turned ON. This alarm occurs if a position reference is input and the setting of Pn520 (2520h) (Excessive Position Deviation Alarm Level) is exceeded before the limit is cleared.	Gr.2	Yes
d10h	Motor-Load Position Deviation Overflow	There was too much position deviation between the motor and load during fully-closed loop control.	Gr.2	Yes
E00h	EtherCAT Module Interface Initialization Timeout Error	Communications initialization failed between the SERVOPACK and the EtherCAT Module.	Gr.2	Yes
E02h	EtherCAT Internal Synchronization Error 1	A synchronization error occurred during EtherCAT communications with the SERVOPACK.	Gr.1	Yes
E03h	EtherCAT Module Interface Communications Data Error	There is an error in the communications data between the SERVOPACK and the EtherCAT Module.	Gr.1	Yes
E72h	Feedback Option Module Detection Failure	Detection of the Feedback Option Module failed.	Gr.1	No
E75h ^{*2}	Unsupported Feedback Option Module Alarm	An unsupported Feedback Option Module was connected.	Gr.1	No
EA0h	Command-Option IF Servo Unit Initial Error	Communications could not be initialized between the SERVOPACK and EtherCAT (CoE) Network Module within 10 seconds.	Gr.1	No
EA1h	Command-Option IF Memory Check Error	An error occurred in communications memory between the SERVOPACK and EtherCAT (CoE) Network Module.	Gr.1	No
EA2h	Command-Option IF Servo Synchronization Error ^{*1}	Communications could not be synchronized between the SERVOPACK and EtherCAT (CoE) Network Module.	Gr.1	Yes
EA3h	Command-Option IF Servo Data Error ^{*1}	An error occurred in communications data between the SERVOPACK and EtherCAT (CoE) Network Module.	Gr.1	Yes
Eb1h	Safety Function Signal Input Timing Error	An error occurred in the input timing of the safety function signal.	Gr.1	No
Ed1h	Command Execution Timeout	A timeout error occurred for a EtherCAT command.	Gr.2	Yes
F10h	Power Supply Line Open Phase	The voltage was low for more than one second for phase R, S, or T when the main power supply was ON.	Gr.2	Yes
FL-1 ^{*3}	System Alarm	An internal program error occurred in the SERVOPACK.	-	No
FL-2 ^{*3}				
FL-3 ^{*3}				
FL-4 ^{*3}				
FL-5 ^{*3}				
FL-6 ^{*3}				

Continued on next page.

Continued from previous page.

Alarm Code	Alarm Name	Alarm Meaning	Servo-motor Stopping Method	Alarm Reset Possible?
CPF00	Digital Operator Communications Error 1	Communications were not possible between the Digital Operator (model: JUSP-OP05A-1-E) and the SERVOPACK (e.g., a CPU error occurred).	-	No
CPF01	Digital Operator Communications Error 2			

*1. The EtherCAT communications state moved to SAFEOP after an alarm was detected.

*2. This alarm can occur when a Fully-Close Option Module is mounted.

*3. These alarms are not stored in the alarm history. They are only displayed on the panel display.

3.1.2 Troubleshooting Alarms

The causes of and corrections for the alarm are given in the following table. Contact your Yaskawa representative if you cannot solve a problem with the correction given in the table.

Alarm Code: Alarm Name	Possible Cause	Confirmation	Correction	Reference
020h: Parameter Checksum Error (There is an error in the parameter data in the SER- VOPACK.)	The power supply voltage suddenly dropped.	Measure the power supply voltage.	Set the power supply voltage within the specified range, and initialize the parameter settings.	*1
	The power supply was shut OFF while writing parameter settings.	Check the timing of shutting OFF the power supply.	Initialize the parameter settings and then set the parameters again.	
	The number of times that parameters were written exceeded the limit.	Check to see if the parameters were frequently changed from the host controller.	The SERVOPACK may be faulty. Replace the SERVOPACK. Reconsider the method for writing the parameters.	-
	A malfunction was caused by noise from the AC power supply, ground, static electricity, or other source.	Turn the power supply to the SERVOPACK OFF and ON again. If the alarm still occurs, noise may be the cause.	Implement countermeasures against noise.	*1
	Gas, water drops, or cutting oil entered the SERVOPACK and caused failure of the internal components.	Check the installation conditions.	The SERVOPACK may be faulty. Replace the SERVOPACK.	-
	A failure occurred in the SERVOPACK.	Turn the power supply to the SERVOPACK OFF and ON again. If the alarm still occurs, the SERVOPACK may have failed.	The SERVOPACK may be faulty. Replace the SERVOPACK.	-
021h: Parameter Format Error (There is an error in the parameter data format in the SERVOPACK.)	The software version of the SERVOPACK that caused the alarm is older than the software version of the parameters specified to write.	Read the product information to see if the software versions are the same. If they are different, it could be the cause of the alarm.	Write the parameters from another SERVOPACK with the same model and the same software version, and then turn the power OFF and ON again.	*1
	A failure occurred in the SERVOPACK.	-	The SERVOPACK may be faulty. Replace the SERVOPACK.	-
022h: System Checksum Error (There is an error in the parameter data in the SERVOPACK.)	The power supply voltage suddenly dropped.	Measure the power supply voltage.	The SERVOPACK may be faulty. Replace the SERVOPACK.	-
	The power supply was shut OFF while setting a utility function.	Check the timing of shutting OFF the power supply.	The SERVOPACK may be faulty. Replace the SERVOPACK.	-
	A failure occurred in the SERVOPACK.	Turn the power supply to the SERVOPACK OFF and ON again. If the alarm still occurs, the SERVOPACK may have failed.	The SERVOPACK may be faulty. Replace the SERVOPACK.	-

Continued on next page.

Continued from previous page.

Alarm Code: Alarm Name	Possible Cause	Confirmation	Correction	Reference
024h: System Alarm (An internal program error occurred in the SERVOPACK.)	A failure occurred in the SERVOPACK.	–	The SERVOPACK may be faulty. Replace the SERVOPACK.	–
025h: System Alarm (An internal program error occurred in the SERVOPACK.)	A failure occurred in the SERVOPACK.	–	The SERVOPACK may be faulty. Replace the SERVOPACK.	–
030h: Main Circuit Detector Error	A failure occurred in the SERVOPACK.	–	The SERVOPACK may be faulty. Replace the SERVOPACK.	–
	The jumper between the DC Reactor terminals (⊖1 and ⊖2) was removed or there is faulty contact.	–	Correct the wiring between the DC Reactor terminals.	–
	The cable between the DC Reactor and SERVOPACK is not wired correctly or there is a faulty contact.			
040h: Parameter Setting Error (A parameter setting is outside of the setting range.)	The SERVOPACK and Servomotor capacities do not match each other.	Check the combination of the SERVOPACK and Servomotor capacities.	Select a proper combination of SERVOPACK and Servomotor capacities.	page 1-5
	A failure occurred in the SERVOPACK.	–	The SERVOPACK may be faulty. Replace the SERVOPACK.	–
	A parameter setting is outside of the setting range.	Check the setting ranges of the parameters that have been changed.	Set the parameters to values within the setting ranges.	–
041h: Encoder Output Pulse Setting Error	The setting of Pn212 (2212h) (Number of Encoder Output Pulses) is outside of the setting range or does not satisfy the setting conditions.	Check the setting of Pn212 (2212h).	Correct the setting of Pn212 (2212h).	*1
042h: Parameter Combination Error	The speed of program jogging went below the setting range when Pn533 (2533h) (Program Jogging Movement Speed) was changed.	Check to see if the detection conditions*2 are satisfied.	Increase the setting of Pn533 (2533h).	*1
044h: Semi-Closed/ Fully-Closed Loop Control Parameter Setting Error	The setting of the Fully-closed Module does not match the setting of Pn002 (2002h) = n.X□□□ (External Encoder Usage).	Check the setting of Pn002 (2002h) = n.X□□□.	Make sure that the setting of the Fully-closed Module agrees with the setting of Pn002 (2002h) = n.X□□□.	*1

Continued on next page.

3.1 Alarm Displays

3.1.2 Troubleshooting Alarms

Continued from previous page.

Alarm Code: Alarm Name	Possible Cause	Confirmation	Correction	Reference
050h: Combination Error (The capacities of the SERVOPACK and Servomotor do not match.)	The SERVOPACK and Servomotor capacities do not match each other.	Confirm that the following condition is met: $1/4 < (\text{Servomotor capacity} / \text{SERVOPACK capacity}) < 4$	Select a proper combination of the SERVOPACK and Servomotor capacities.	page 1-5
	A failure occurred in the encoder.	Replace the encoder and check to see if the alarm still occurs.	Replace the Servomotor or encoder.	–
	A failure occurred in the SERVOPACK.	–	The SERVOPACK may be faulty. Replace the SERVOPACK.	–
051h: Unsupported Device Alarm	An unsupported Serial Converter Unit or encoder (e.g., an external encoder) is connected to the SERVOPACK.	Check the product combination specifications.	Change to a correct combination of models.	–
070h: Motor Type Change Detected (The connected motor is a different type of motor from the previously connected motor.)	A Rotary Servomotor was removed and a Linear Servomotor was connected.	–	Execute a Reset Motor Type Alarm operation. Then, turn the power supply to the SERVOPACK OFF and ON again.	*1
	A Linear Servomotor was removed and a Rotary Servomotor was connected.	–	Set the parameters for a Rotary Servomotor and reset the motor type alarm. Then, turn the power supply to the SERVOPACK OFF and ON again.	*1
0b0h: Invalid Servo ON Command Alarm	The Servo ON command (Enable Operation command) was sent from the host controller after a utility function that turns ON the Servomotor was executed.	–	Turn the power supply to the SERVOPACK OFF and ON again. Or, execute a software reset.	*1

Continued on next page.

Continued from previous page.

Alarm Code: Alarm Name	Possible Cause	Confirmation	Correction	Reference
100h: Overcurrent Detected (An overcurrent flowed through the power trans- former or the heat sink overheated.)	The Main Circuit Cable is not wired correctly or there is faulty contact.	Check the wiring.	Correct the wiring.	*1
	There is a short-circuit or ground fault in a Main Circuit Cable.	Check for short-circuits across Servomotor phases U, V, and W, or between the ground and Servomotor phases U, V, and W.	The cable may be short- circuited. Replace the cable.	
	There is a short-circuit or ground fault inside the Servomotor.	Check for short-circuits across Servomotor phases U, V, and W, or between the ground and Servomotor phases U, V, or W.	The Servomotor may be faulty. Replace the Servo- motor or encoder.	
	There is a short-circuit or ground fault inside the SERVOPACK.	Check for short-circuits across the Servomotor connection terminals U, V, and W on the SER- VOPACK, or between the ground and termi- nals U, V, or W.	The SERVOPACK may be faulty. Replace the SER- VOPACK.	
	The regenerative resistor is not wired correctly or there is faulty contact.	Check the wiring.	Correct the wiring.	
	The dynamic brake (DB, emergency stop executed from the SERVOPACK) was frequently activated, or a DB overload alarm occurred.	Check the power con- sumed by the DB resis- tor to see how frequently the DB is being used. Or, check the alarm display to see if a DB overload alarm (A.730 or A.731) has occurred.	Change the SERVOPACK model, operating meth- ods, or the mechanisms so that the dynamic brake does not need to be used so frequently.	-

Continued on next page.

3.1 Alarm Displays

3.1.2 Troubleshooting Alarms

Continued from previous page.

Alarm Code: Alarm Name	Possible Cause	Confirmation	Correction	Reference
100h: Overcurrent Detected (An overcurrent flowed through the power trans- former or the heat sink overheated.)	The regenerative processing capacity was exceeded.	Check the regenerative load ratio in the SigmaWin+ Motion Monitor Tab Page to see how frequently the regenerative resistor is being used.	Recheck the operating conditions and load.	*3
	The SERVOPACK regenerative resistance is too small.	Check the regenerative load ratio in the SigmaWin+ Motion Monitor Tab Page to see how frequently the regenerative resistor is being used.	Change the regenerative resistance to a value larger than the SERVOPACK minimum allowable resistance.	-
	A heavy load was applied while the Servomotor was stopped or running at a low speed.	Check to see if the operating conditions exceed Servo Drive specifications.	Reduce the load applied to the Servomotor. Or, increase the operating speed.	-
	A malfunction was caused by noise.	Improve the noise environment, e.g. by improving the wiring or installation conditions, and check to see if the alarm still occurs.	Implement countermeasures against noise, such as correct wiring of the FG. Use an FG wire size equivalent to the SERVOPACK's main circuit wire size.	-
	A failure occurred in the SERVOPACK.	-	Turn the power supply to the SERVOPACK OFF and ON again. If the alarm still occurs, the SERVOPACK may be faulty. Replace the SERVOPACK.	-
300h: Regeneration Error	When using the built-in regenerative resistor, the jumper between the regenerative resistor terminals (B2 and B3) was removed.	Check to see if the jumper is connected between power supply terminals B2 and B3.*4	Correctly connect a jumper.	*1
	The External Regenerative Resistor is not wired correctly, or was removed or disconnected.	Check the wiring of the External Regenerative Resistor.*4	Correct the wiring of the External Regenerative Resistor.	
	A failure occurred in the SERVOPACK.	-	While the main circuit power supply is OFF, turn the control power supply to the SERVOPACK OFF and ON again. If the alarm still occurs, the SERVOPACK may be faulty. Replace the SERVOPACK.	-

Continued on next page.

Continued from previous page.

Alarm Code: Alarm Name	Possible Cause	Confirmation	Correction	Reference
320h: Regenerative Overload	The power supply voltage exceeded the specified range.	Measure the power supply voltage.	Set the power supply voltage within the specified range.	–
	The external regenerative resistance value or regenerative resistor capacity is too small, or there has been a continuous regeneration state.	Check the operating conditions and capacity again.	Change the regenerative resistance value or capacity. Recheck the operating conditions.	*3
	There was a continuous regeneration state because a negative load was continuously applied.	Check the load applied to the Servomotor during operation.	Reconsider the system including the servo, machine, and operating conditions.	–
	The setting of Pn600 (2600h) (Regenerative Resistor Capacity) is smaller than the capacity of the External Regenerative Resistor.	Check to see if a Regenerative Resistor is connected and check the setting of Pn600 (2600h).	Correct the setting of Pn600 (2600h).	*1
	The setting of Pn603 (2603h) (Regenerative Resistance) is smaller than the capacity of the External Regenerative Resistor.	Check to see if a Regenerative Resistor is connected and check the setting of Pn603 (2603h).	Correct the setting of Pn603 (2603h).	*1
	The external regenerative resistance is too high.	Check the regenerative resistance.	Change the regenerative resistance to a correct value or use an External Regenerative Resistor of an appropriate capacity.	*3
	A failure occurred in the SERVOPACK.	–	The SERVOPACK may be faulty. Replace the SERVOPACK.	–
330h: Main Circuit Power Supply Wiring Error (Detected when the main circuit power supply is turned ON.)	The regenerative resistor was disconnected when the SERVOPACK power supply voltage was high.	Measure the resistance of the regenerative resistor using a measuring instrument.	If you are using the regenerative resistor built into the SERVOPACK, replace the SERVOPACK. If you are using an External Regenerative Resistor, replace the External Regenerative Resistor.	–
	DC power was supplied when an AC power supply input was specified in the settings.	Check the power supply to see if it is a DC power supply.	Correct the power supply setting to match the actual power supply.	*1
	AC power was supplied when a DC power supply input was specified in the settings.	Check the power supply to see if it is an AC power supply.	Correct the power supply setting to match the actual power supply.	
	A failure occurred in the SERVOPACK.	–	The SERVOPACK may be faulty. Replace the SERVOPACK.	–

Continued on next page.

3.1 Alarm Displays

3.1.2 Troubleshooting Alarms

Continued from previous page.

Alarm Code: Alarm Name	Possible Cause	Confirmation	Correction	Reference
400h: Overvoltage (Detected in the main circuit power supply section of the SERVOPACK.)	The power supply voltage exceeded the specified range.	Measure the power supply voltage.	Set the AC/DC power supply voltage within the specified range.	–
	The power supply is not stable or was influenced by a lightning surge.	Measure the power supply voltage.	Improve the power supply conditions, install a surge absorber, and then turn the power supply OFF and ON again. If the alarm still occurs, the SERVOPACK may be faulty. Replace the SERVOPACK.	–
	The voltage for AC power supply was too high during acceleration or deceleration.	Check the power supply voltage and the speed and torque during operation.	Set the AC power supply voltage within the specified range.	–
	The external regenerative resistance is too high for the operating conditions.	Check the operating conditions and the regenerative resistance.	Select a regenerative resistance value that is appropriate for the operating conditions and load.	*3
	The moment of inertia ratio or mass ratio exceeded the allowable value.	Check to see if the moment of inertia ratio or mass ratio is within the allowable range.	Increase the deceleration time, or reduce the load.	–
	A failure occurred in the SERVOPACK.	–	While the main circuit power supply is OFF, turn the control power supply to the SERVOPACK OFF and ON again. If the alarm still occurs, the SERVOPACK may be faulty. Replace the SERVOPACK.	–

Continued on next page.

Continued from previous page.

Alarm Code: Alarm Name	Possible Cause	Confirmation	Correction	Reference
410h: Undervoltage (Detected in the main circuit power supply section of the SERVOPACK.)	The power supply voltage went below the specified range.	Measure the power supply voltage.	Set the power supply voltage within the specified range.	–
	The power supply voltage dropped during operation.	Measure the power supply voltage.	Increase the power supply capacity.	–
	A momentary power interruption occurred.	Measure the power supply voltage.	If you have changed the setting of Pn509 (2509h) (Momentary Power Interruption Hold Time), decrease the setting.	*1
	The SERVOPACK fuse is blown out.	Check the power supply wiring.	Correct the power supply wiring and replace the SERVOPACK.	–
	The SERVOPACK fuse is blown out.	–	Replace the SERVOPACK and connect a reactor to the DC reactor terminals (⊖1 and ⊖2) on the SERVOPACK.	–
	A failure occurred in the SERVOPACK.	–	The SERVOPACK may be faulty. Replace the SERVOPACK.	–
	The jumper between the DC Reactor terminals (⊖1 and ⊖2) was removed or there is faulty contact.	–	Correct the wiring between the DC Reactor terminals.	–
The cable between the DC Reactor and SERVOPACK is not wired correctly or there is a faulty contact.	–			
510h: Overspeed (The motor exceeded the maximum speed.)	The order of phases U, V, and W in the motor wiring is not correct.	Check the wiring of the Servomotor.	Make sure that the Servomotor is correctly wired.	–
	A reference value that exceeded the overspeed detection level was input.	Check the input reference.	Reduce the reference value. Or, adjust the gain.	–
	The motor exceeded the maximum speed.	Check the waveform of the motor speed.	Reduce the speed reference input gain and adjust the servo gain. Or, reconsider the operating conditions.	–
	A failure occurred in the SERVOPACK.	–	The SERVOPACK may be faulty. Replace the SERVOPACK.	–
511h: Encoder Output Pulse Overspeed	The encoder output pulse frequency exceeded the limit.	Check the encoder output pulse setting.	Decrease the setting of Pn212 (2212h) (Number of Encoder Output Pulses).	*1
	The encoder output pulse frequency exceeded the limit because the motor speed was too high.	Check the encoder output pulse setting and the motor speed.	Reduce the motor speed.	–

Continued on next page.

3.1 Alarm Displays

3.1.2 Troubleshooting Alarms

Continued from previous page.

Alarm Code: Alarm Name	Possible Cause	Confirmation	Correction	Reference
520h: Vibration Alarm	Abnormal oscillation was detected in the motor speed.	Check for abnormal Servomotor noise, and check the speed and torque waveforms during operation.	Reduce the motor speed. Or, reduce the setting of Pn100 (2100h) (Speed Loop Gain).	*1
	The setting of Pn103 (2103h) (Moment of Inertia Ratio) is greater than the actual moment of inertia or was greatly changed.	Check the moment of inertia ratio or mass ratio.	Correct the setting of Pn103 (2103h).	*1
	The vibration detection level (Pn312) is not suitable.	Check that the vibration detection level (Pn312) is suitable.	Set a suitable vibration detection level (Pn312).	*1
521h: Autotuning Alarm (Vibration was detected while executing the custom tuning, Easy FFT, or the tuning-less function.)	The Servomotor vibrated considerably while performing the tuning-less function.	Check the waveform of the motor speed.	Reduce the load so that the moment of inertia ratio is within the allowable value. Or increase the load level or reduce the rigidity level in the tuning-less level settings.	*1
	The Servomotor vibrated considerably while performing custom tuning or EasyFFT.	Check the waveform of the motor speed.	Check the operating procedure of corresponding function and implement corrections.	*1
550h: Maximum Speed Setting Error	The setting of Pn316 (2316h) (Maximum Motor Speed) is greater than the maximum speed.	Check the setting of Pn316 (2316h), and the upper limits of the maximum motor speed setting and the encoder output resolution setting.	Set Pn316 (2316h) to a value that does not exceed the maximum motor speed.	*1
710h: Instantaneous Overload 720h: Continuous Overload	The wiring is not correct or there is a faulty connection in the motor or encoder wiring.	Check the wiring.	Make sure that the Servomotor and encoder are correctly wired.	*1
	Operation was performed that exceeded the overload protection characteristics.	Check the Servomotor overload characteristics and operation reference.	Consider the following: • Reconsider the load and operating conditions. • Select a Servomotor again.	–
	An excessive load was applied during operation because the Servomotor was not driven because of mechanical problems.	Check the operation reference and motor speed.	Correct the mechanical problem.	–
	Operation was performed with a load applied to the shaft of the servomotor that exceeded the allowable value.	Check the condition of the machine to determine if a load was applied to the shaft of the servomotor that exceeded the allowable value.	Correct the condition of the machine so that the load on the shaft during servomotor operation does not exceed the allowable value.	–
	A failure occurred in the SERVOPACK.	–	The SERVOPACK may be faulty. Replace the SERVOPACK.	–

Continued on next page.

Continued from previous page.

Alarm Code: Alarm Name	Possible Cause	Confirmation	Correction	Reference
730h and 731h: Dynamic Brake Overload (An excessive power consump- tion by the dynamic brake was detected.)	The Servomotor was rotated by an external force.	Check the operation status.	Implement measures to ensure that the Servomotor will not be rotated by an external force.	-
	When the Servomotor or Actuator was stopped with the dynamic brake, the rotational or linear kinetic energy exceeded the capacity of the dynamic brake resistor.	Check the power consumed by the DB resistor to see how frequently the DB is being used.	Reconsider the following: <ul style="list-style-type: none"> • Reduce the Servomotor command speed. • Decrease the moment of inertia ratio or mass ratio. • Reduce the frequency of stopping with the dynamic brake. 	-
	A failure occurred in the SERVOPACK.	-	The SERVOPACK may be faulty. Replace the SERVOPACK.	-
740h: Inrush Current Limiting Resistor Overload (The main circuit power supply was frequently turned ON and OFF.)	The allowable frequency of the inrush current limiting resistor was exceeded when the main circuit power supply was turned ON and OFF.	-	Reduce the frequency of turning the main circuit power supply ON and OFF.	-
	A failure occurred in the SERVOPACK.	-	The SERVOPACK may be faulty. Replace the SERVOPACK.	-
7A1h: Internal Tempera- ture Error 1 (Control Board Temperature Error)	The surrounding temperature is too high.	Check the surrounding temperature using a thermometer. Or, check the operating status with the SERVOPACK installation environment monitor.	Decrease the surrounding temperature by improving the SERVOPACK installation conditions.	*1
	An overload alarm was reset by turning OFF the power supply too many times.	Check the alarm display to see if there is an overload alarm.	Change the method for resetting the alarm.	-
	There was an excessive load or operation was performed that exceeded the regenerative processing capacity.	Use the accumulated load ratio to check the load during operation, and use the regenerative load ratio to check the regenerative processing capacity.	Reconsider the load and operating conditions.	-
	The SERVOPACK installation orientation is not correct or there is insufficient space around the SERVOPACK.	Check the SERVOPACK installation conditions.	Install the SERVOPACK according to specifications.	*1
	A failure occurred in the SERVOPACK.	-	The SERVOPACK may be faulty. Replace the SERVOPACK.	-

Continued on next page.

3.1 Alarm Displays

3.1.2 Troubleshooting Alarms

Continued from previous page.

Alarm Code: Alarm Name	Possible Cause	Confirmation	Correction	Reference
7A2h: Internal Temperature Error 2 (Power Board Temperature Error)	The surrounding temperature is too high.	Check the surrounding temperature using a thermometer. Or, check the operating status with the SERVOPACK installation environment monitor.	Decrease the surrounding temperature by improving the SERVOPACK installation conditions.	*1
	An overload alarm was reset by turning OFF the power supply too many times.	Check the alarm display to see if there is an overload alarm.	Change the method for resetting the alarm.	—
	There was an excessive load or operation was performed that exceeded the regenerative processing capacity.	Use the accumulated load ratio to check the load during operation, and use the regenerative load ratio to check the regenerative processing capacity.	Reconsider the load and operating conditions.	—
	The SERVOPACK installation orientation is not correct or there is insufficient space around the SERVOPACK.	Check the SERVOPACK installation conditions.	Install the SERVOPACK according to specifications.	*1
	A failure occurred in the SERVOPACK.	—	The SERVOPACK may be faulty. Replace the SERVOPACK.	—
7A3h: Internal Temperature Sensor Error (An error occurred in the temperature sensor circuit.)	A failure occurred in the SERVOPACK.	—	The SERVOPACK may be faulty. Replace the SERVOPACK.	—
7Abh: SERVOPACK Built-in Fan Stopped	The fan inside the SERVOPACK stopped.	Check for foreign matter inside the SERVOPACK.	Remove foreign matter from the SERVOPACK. If the alarm still occurs, the SERVOPACK may be faulty. Replace the SERVOPACK.	—
810h: Encoder Backup Alarm (Detected at the encoder, but only when an absolute encoder is used.)	The power to the absolute encoder was turned ON for the first time.	Check to see if the power supply was turned ON for the first time.	Set up the encoder.	—
	The Encoder Cable was disconnected and then connected again.	Check to see if the power supply was turned ON for the first time.	Check the encoder connection and set up the encoder.	*1
	Power is not being supplied both from the control power supply (+5 V) from the SERVOPACK and from the battery power supply.	Check the encoder connector battery and the connector status.	Replace the battery or implement similar measures to supply power to the encoder, and set up the encoder.	—
	A failure occurred in the encoder.	—	If the alarm still occurs after setting up the encoder again, replace the Servomotor.	—
	A failure occurred in the SERVOPACK.	—	The SERVOPACK may be faulty. Replace the SERVOPACK.	—

Continued on next page.

Continued from previous page.

Alarm Code: Alarm Name	Possible Cause	Confirmation	Correction	Reference
820h: Encoder Check-sum Alarm (Detected at the encoder.)	A failure occurred in the encoder.	–	Set up the encoder again. If the alarm still occurs, the Servomotor may be faulty. Replace the Servomotor.	*1
	A failure occurred in the SERVOPACK.	–	The SERVOPACK may be faulty. Replace the SERVOPACK.	–
830h: Encoder Battery Alarm (The absolute encoder battery voltage was lower than the specified level.)	The battery connection is faulty or a battery is not connected.	Check the battery connection.	Correct the battery connection.	*1
	The battery voltage is lower than the specified value.	Measure the battery voltage.	Replace the battery.	*1
	A failure occurred in the SERVOPACK.	–	The SERVOPACK may be faulty. Replace the SERVOPACK.	–
840h: Encoder Data Alarm (Detected at the encoder.)	The encoder malfunctioned.	–	Turn the power supply to the SERVOPACK OFF and ON again. If the alarm still occurs, the Servomotor may be faulty. Replace the Servomotor or encoder.	–
	The encoder malfunctioned due to noise.	–	Correct the wiring around the encoder by separating the Encoder Cable from the Servomotor Main Circuit Cable or by grounding the encoder.	–
850h: Encoder Over-speed (Detected at the encoder.)	The Servomotor speed was 200 min ⁻¹ or higher when the control power supply was turned ON.	Check the motor speed when the power supply is turned ON.	Reduce the Servomotor speed to a value less than 200 min ⁻¹ , and turn ON the control power supply.	–
	A failure occurred in the encoder.	–	Turn the power supply to the SERVOPACK OFF and ON again. If the alarm still occurs, the Servomotor or encoder may be faulty. Replace the Servomotor or encoder.	–
	A failure occurred in the SERVOPACK.	–	Turn the power supply to the SERVOPACK OFF and ON again. If the alarm still occurs, the SERVOPACK may be faulty. Replace the SERVOPACK.	–

Continued on next page.

3.1 Alarm Displays

3.1.2 Troubleshooting Alarms

Continued from previous page.

Alarm Code: Alarm Name	Possible Cause	Confirmation	Correction	Reference
860h: Encoder Over-heated (Detected at the encoder.)	The surrounding air temperature around the Servomotor is too high.	Measure the surrounding air temperature around the Servomotor.	Reduce the surrounding air temperature of the Servomotor to 40° or less.	–
	The Servomotor is operating outside the continuous duty zone.	Use the accumulated load ratio to check the load.	Operate the Servomotor within the continuous duty zone.	*1
	A failure occurred in the encoder.	–	Turn the power supply to the SERVOPACK OFF and ON again. If the alarm still occurs, the Servomotor or encoder may be faulty. Replace the Servomotor or encoder.	–
	A failure occurred in the SERVOPACK.	–	Turn the power supply to the SERVOPACK OFF and ON again. If the alarm still occurs, the SERVOPACK may be faulty. Replace the SERVOPACK.	–
8A0h: External Encoder Error	A failure occurred in the external encoder.	–	Replace the external encoder.	–
8A1h: External Encoder Module Error	A failure occurred in the external encoder.	–	Replace the external encoder.	–
	A failure occurred in the Serial Converter Unit.	–	Replace the Serial Converter Unit.	–
8A2h: External Incremental Encoder Sensor Error	A failure occurred in the external encoder.	–	Replace the external encoder.	–
8A3h: External Absolute Encoder Position Error	A failure occurred in the external absolute encoder.	–	The external absolute encoder may be faulty. Refer to the encoder manufacturer's instruction manual for corrections.	–
8A5h: External Encoder Overspeed	An overspeed error was detected in the external encoder.	Check the maximum speed of the external encoder.	Keep the external encoder below its maximum speed.	–
8A6h: External Encoder Overheated	An overheating error was detected in the external encoder.	–	Replace the external encoder.	–
A10h: EtherCAT DC Synchronization Error	The synchronization timing (Sync0) for EtherCAT communications fluctuated.	–	Turn the power supply OFF and ON again and re-establish communications.	–
A11h: EtherCAT State Error	The EtherCAT communications state left the Operational state during motor operation.	–	Reset the alarm and then re-establish communications.	–

Continued on next page.

Continued from previous page.

Alarm Code: Alarm Name	Possible Cause	Confirmation	Correction	Reference
A12h: EtherCAT Output Data Synchroni- zation Error	Noise caused an error in EtherCAT communications.	–	Check the EtherCAT wiring and implement noise countermeasures.	–
	The controller did not update the process data during the fixed period.	Check the process data specified by the controller.	Correct the controller so that the process data is updated during the fixed period.	–
	The EtherCAT Communications Cable or connector wiring is faulty.	Check the EtherCAT Communications Cable and connector wiring.	Wire the connections correctly.	–
A20h: Parameter Set- ting Error	The position unit is outside of the setting range.	Make sure it is within the following range. $1/4,096 < \text{Numerator (2701h: 1)}/\text{Denominator (2701h: 2)} < 65,536$	Correct the setting of <i>position user unit</i> (2701h).	–
	The speed unit is outside of the setting range.	Make sure it is within the following range. $1/128 \leq \text{Numerator (2702h: 1)}/\text{Denominator (2702h: 2)} \leq 8,388,608$	Correct the setting of <i>velocity user unit</i> (2702h).	–
	The acceleration unit is outside of the setting range.	Make sure it is within the following range. $1/128 \leq \text{Numerator (2703h: 1)}/\text{Denominator (2703h: 2)} \leq 262,144$	Correct the setting of <i>acceleration user unit</i> (2703h).	–
A40h: System Initializa- tion Error	A failure occurred in the SERVOPACK.	–	Replace the SERVOPACK.	–
A41h: Communications Device Initializa- tion Error	A failure occurred in the SERVOPACK.	–	Replace the SERVOPACK.	–
A47h: Loading Servo Information Error	<i>User parameter configuration</i> (2700h) was executed while a utility function (Fn□□□) was being executed from the Digital Operator or SigmaWin+.	–	Turn the power supply OFF and ON again.	–
	The power supply was turned ON or <i>user parameter configuration</i> (2700h) was executed when an encoder was not connected.	Check the wiring of the encoder.	Turn OFF the power supply, correct the encoder connection, and then turn the power supply back ON.	–
	The power supply was turned ON or <i>user parameter configuration</i> (2700h) was executed when there was a Parameter Setting Error (alarm 040h).	Check the parameter settings.	Correct the parameter settings and turn the power supply OFF and ON again.	–
	A failure occurred in the SERVOPACK.	–	Replace the SERVOPACK.	–

Continued on next page.

3.1 Alarm Displays

3.1.2 Troubleshooting Alarms

Continued from previous page.

Alarm Code: Alarm Name	Possible Cause	Confirmation	Correction	Reference
A48h: EEPROM Parameter Data Error	The power supply was shut OFF while writing parameter settings.	Check the timing of shutting OFF the power supply.	Initialize the parameter settings (<i>restore default parameters</i> (1011h)) and then set the parameters again.	-
	The number of times that parameters were written exceeded the limit.	-	Repair or replace the SERVOPACK. Reconsider the method for writing the parameters.	-
	The power supply voltage suddenly dropped.	Measure the power supply voltage.	Set the power supply voltage within the specified range, and initialize the parameter settings (<i>restore default parameters</i> (1011h)).	-
	A failure occurred in the SERVOPACK.	-	Replace the SERVOPACK.	-
b33h: Current Detection Error 3	A failure occurred in the current detection circuit.	-	Turn the power supply to the SERVOPACK OFF and ON again. If the alarm still occurs, the SERVOPACK may be faulty. Replace the SERVOPACK.	-
bF0h: System Alarm 0	A failure occurred in the SERVOPACK.	-	Turn the power supply to the SERVOPACK OFF and ON again. If the alarm still occurs, the SERVOPACK may be faulty. Replace the SERVOPACK.	-
bF1h: System Alarm 1	A failure occurred in the SERVOPACK.	-	Turn the power supply to the SERVOPACK OFF and ON again. If the alarm still occurs, the SERVOPACK may be faulty. Replace the SERVOPACK.	-
bF2h: System Alarm 2	A failure occurred in the SERVOPACK.	-	Turn the power supply to the SERVOPACK OFF and ON again. If the alarm still occurs, the SERVOPACK may be faulty. Replace the SERVOPACK.	-
bF3h: System Alarm 3	A failure occurred in the SERVOPACK.	-	Turn the power supply to the SERVOPACK OFF and ON again. If the alarm still occurs, the SERVOPACK may be faulty. Replace the SERVOPACK.	-
bF4h: System Alarm 4	A failure occurred in the SERVOPACK.	-	Turn the power supply to the SERVOPACK OFF and ON again. If the alarm still occurs, the SERVOPACK may be faulty. Replace the SERVOPACK.	-
bF5h: System Alarm 5	A failure occurred in the SERVOPACK.	-	Turn the power supply to the SERVOPACK OFF and ON again. If the alarm still occurs, the SERVOPACK may be faulty. Replace the SERVOPACK.	-

Continued on next page.

Continued from previous page.

Alarm Code: Alarm Name	Possible Cause	Confirmation	Correction	Reference
bF6h: System Alarm 6	A failure occurred in the SERVOPACK.	—	Turn the power supply to the SERVOPACK OFF and ON again. If the alarm still occurs, the SERVOPACK may be faulty. Replace the SERVOPACK.	—
bF7h: System Alarm 7	A failure occurred in the SERVOPACK.	—	Turn the power supply to the SERVOPACK OFF and ON again. If the alarm still occurs, the SERVOPACK may be faulty. Replace the SERVOPACK.	—
bF8h: System Alarm 8	A failure occurred in the SERVOPACK.	—	Turn the power supply to the SERVOPACK OFF and ON again. If the alarm still occurs, the SERVOPACK may be faulty. Replace the SERVOPACK.	—
C10h: Servomotor Out of Control (Detected when the servo is turned ON.)	The order of phases U, V, and W in the motor wiring is not correct.	Check the Servomotor wiring.	Make sure that the Servomotor is correctly wired.	—
	A failure occurred in the encoder.	—	If the motor wiring is correct and the alarm still occurs after turning the power supply OFF and ON again, the Servomotor or encoder may be faulty. Replace the Servomotor or encoder.	—
	A failure occurred in the SERVOPACK.	—	Turn the power supply to the SERVOPACK OFF and ON again. If the alarm still occurs, the SERVOPACK may be faulty. Replace the SERVOPACK.	—
C80h: Encoder Clear Error or Multiturn Limit Setting Error	A failure occurred in the encoder.	—	Turn the power supply to the SERVOPACK OFF and ON again. If the alarm still occurs, the Servomotor or encoder may be faulty. Replace the Servomotor or encoder.	—
	A failure occurred in the SERVOPACK.	—	Turn the power supply to the SERVOPACK OFF and ON again. If the alarm still occurs, the SERVOPACK may be faulty. Replace the SERVOPACK.	—

Continued on next page.

3.1 Alarm Displays

3.1.2 Troubleshooting Alarms

Continued from previous page.

Alarm Code: Alarm Name	Possible Cause	Confirmation	Correction	Reference
C90h: Encoder Commu- nications Error	There is a faulty con- tact in the connector or the connector is not wired correctly for the encoder.	Check the condition of the encoder connector.	Reconnect the encoder connector and check the encoder wiring.	*1
	There is a cable dis- connection or short- circuit in the encoder. Or, the cable imped- ance is outside the specified values.	Check the condition of the Encoder Cable.	Use the Encoder Cable within the specified speci- fications.	–
	One of the following has occurred: corro- sion caused by improper tempera- ture, humidity, or gas, a short-circuit caused by entry of water drops or cutting oil, or faulty contact in con- nector caused by vibration.	Check the operating environment.	Improve the operating environment, and replace the cable. If the alarm still occurs, replace the SER- VOPACK.	*1
	A malfunction was caused by noise.	–	Correct the wiring around the encoder by separating the Encoder Cable from the Servomotor Main Cir- cuit Cable or by ground- ing the encoder.	*1
	A failure occurred in the SERVOPACK.	–	Connect the Servomotor to another SERVOPACK, and turn ON the control power supply. If no alarm occurs, the SERVOPACK may be faulty. Replace the SERVOPACK.	–
	A failure occurred in the encoder.	–	Connect the Servomotor to another SERVOPACK, and turn ON the control power supply. If the alarm occurs, the Servomotor may be faulty. Replace the Servomotor.	–
C91h: Encoder Commu- nications Posi- tion Data Acceleration Rate Error	Noise entered on the signal lines because the Encoder Cable is bent or the sheath is damaged.	Check the condition of the Encoder Cable and connectors.	Check the Encoder Cable to see if it is installed cor- rectly.	*1
	The Encoder Cable is bundled with a high- current line or installed near a high- current line.	Check the installation condition of the Encoder Cable.	Confirm that there is no surge voltage on the Encoder Cable.	–
	There is variation in the FG potential because of the influ- ence of machines on the Servomotor side, such as a welder.	Check the installation condition of the Encoder Cable.	Properly ground the machine to separate it from the FG of the encoder.	–

Continued on next page.

Continued from previous page.

Alarm Code: Alarm Name	Possible Cause	Confirmation	Correction	Reference
C92h: Encoder Commu- nications Timer Error	Noise entered on the signal line from the encoder.	–	Implement countermeasures against noise for the encoder wiring.	*1
	Excessive vibration or shock was applied to the encoder.	Check the operating conditions.	Reduce machine vibration. Correctly install the Servomotor or encoder.	–
	A failure occurred in the encoder.	–	Turn the power supply to the SERVOPACK OFF and ON again. If the alarm still occurs, the Servomotor or encoder may be faulty. Replace the Servomotor or encoder.	–
	A failure occurred in the SERVOPACK.	–	Turn the power supply to the SERVOPACK OFF and ON again. If the alarm still occurs, the SERVOPACK may be faulty. Replace the SERVOPACK.	–
CA0h: Encoder Parame- ter Error	A failure occurred in the encoder.	–	Turn the power supply to the SERVOPACK OFF and ON again. If the alarm still occurs, the Servomotor or encoder may be faulty. Replace the Servomotor or encoder.	–
	A failure occurred in the SERVOPACK.	–	Turn the power supply to the SERVOPACK OFF and ON again. If the alarm still occurs, the SERVOPACK may be faulty. Replace the SERVOPACK.	–

Continued on next page.

3.1 Alarm Displays

3.1.2 Troubleshooting Alarms

Continued from previous page.

Alarm Code: Alarm Name	Possible Cause	Confirmation	Correction	Reference
Cb0h: Encoder Echo- back Error	The encoder is wired incorrectly or there is faulty contact.	Check the wiring of the encoder.	Make sure that the encoder is correctly wired.	*1
	The specifications of the Encoder Cable are not correct and noise entered on it.	–	Use a shielded twisted-pair wire cable or a screened twisted-pair cable with conductors of at least 0.12 mm ² .	–
	The Encoder Cable is too long and noise entered on it.	–	The Encoder Cable wiring distance must be 20 m max.	–
	There was variation in the FG potential because of the influence of machines on the Servomotor or Actuator side, such as a welder.	Check the condition of the Encoder Cable and connectors.	Properly ground the machine to separate it from the FG of the encoder.	–
	Excessive vibration or shock was applied to the encoder.	Check the operating conditions.	Reduce machine vibration. Correctly install the Servomotor or encoder.	–
	A failure occurred in the encoder.	–	Turn the power supply to the SERVOPACK OFF and ON again. If the alarm still occurs, the Servomotor or encoder may be faulty. Replace the Servomotor or encoder.	–
	A failure occurred in the SERVOPACK.	–	Turn the power supply to the SERVOPACK OFF and ON again. If the alarm still occurs, the SERVOPACK may be faulty. Replace the SERVOPACK.	–
CC0h: Multiturn Limit Disagreement	When using a Direct Drive Servomotor, the setting of Pn205 (2205h) (Multiturn Limit) does not agree with the encoder.	Check the setting of Pn205 (2205h).	Correct the setting of Pn205 (2205h) (0 to 65,535).	*1
	The multiturn limit of the encoder is different from that of the SERVOPACK. Or, the multiturn limit of the SERVOPACK has been changed.	Check the setting of Pn205 (2205h) (Multiturn Limit).	Change the setting if the alarm occurs.	–
	A failure occurred in the SERVOPACK.	–	Turn the power supply to the SERVOPACK OFF and ON again. If the alarm still occurs, the SERVOPACK may be faulty. Replace the SERVOPACK.	–

Continued on next page.

Continued from previous page.

Alarm Code: Alarm Name	Possible Cause	Confirmation	Correction	Reference
CF1h: Reception Failed Error in Feed- back Option Module Commu- nications	The cable between the Serial Converter Unit and SERVOPACK is not wired correctly or there is a faulty contact.	Check the wiring of the external encoder.	Correctly wire the cable between the Serial Converter Unit and SERVOPACK.	*1
	A specified cable is not being used between Serial Converter Unit and SERVOPACK.	Check the wiring specifications of the external encoder.	Use a specified cable.	-
	The cable between the Serial Converter Unit and SERVOPACK is too long.	Measure the length of the cable that connects the Serial Converter Unit.	The length of the cable between the Serial Converter Unit and SERVOPACK must be 20 m or less.	-
	The sheath on cable between the Serial Converter Unit and SERVOPACK is broken.	Check the cable that connects the Serial Converter Unit.	Replace the cable between the Serial Converter Unit and SERVOPACK.	-
CF2h: Timer Stopped Error in Feed- back Option Module Commu- nications	Noise entered the cable between the Serial Converter Unit and SERVOPACK.	-	Correct the wiring around the Serial Converter Unit, e.g., separate I/O signal lines from the Main Circuit Cables or ground.	-
	A failure occurred in the Serial Converter Unit.	-	Replace the Serial Converter Unit.	-
	A failure occurred in the SERVOPACK.	-	Replace the SERVOPACK.	-
d00h: Position Devia- tion Overflow (The setting of Pn520 (2520h) (Excessive Posi- tion Error Alarm Level) was exceeded by the position deviation.)	The Servomotor U, V, and W wiring is not correct.	Check the wiring of the Servomotor's Main Circuit Cables.	Make sure that there are no faulty contacts in the wiring for the Servomotor and encoder.	-
	The position command speed is too fast.	Reduce the position command speed and try operating the SERVOPACK.	Reduce the position reference speed or the reference acceleration rate, or reconsider the electronic gear ratio.	*1
	The acceleration of the position reference is too high.	Reduce the reference acceleration and try operating the SERVOPACK.	Reduce the acceleration of the position reference using an EtherCAT command.	-
	The setting of Pn520 (2520h) (Excessive Position Deviation Alarm Level) is too low for the operating conditions.	Check the setting of Pn520 (2520h) to see if it is appropriate.	Optimize the setting of Pn520 (2520h).	*1
	A failure occurred in the SERVOPACK.	-	Turn the power supply to the SERVOPACK OFF and ON again. If the alarm still occurs, the SERVOPACK may be faulty. Replace the SERVOPACK.	-

Continued on next page.

3.1 Alarm Displays

3.1.2 Troubleshooting Alarms

Continued from previous page.

Alarm Code: Alarm Name	Possible Cause	Confirmation	Correction	Reference
d01h: Position Deviation Overflow Alarm at Servo ON	The servo was turned ON after the position deviation exceeded the setting of Pn526 (2526h) (Excessive Position Deviation Alarm Level at Servo ON) while the servo was OFF.	Check the position deviation while the servo is OFF.	Optimize the setting of Pn526 (2526h).	*1
d02h: Position Deviation Overflow Alarm for Speed Limit at Servo ON	If position deviation remains in the deviation counter, the setting of Pn529 (2529h) (Speed Limit Level at Servo ON) will limit the speed when the servo is turned ON. This alarm occurs if a position reference is input and the setting of Pn520 (2520h) (Position Deviation Overflow Alarm Level) is exceeded.	–	Optimize the setting of Pn520 (2520h). Or, set Pn529 (2529h) to an appropriate value.	*1
d10h: Motor-Load Position Deviation Overflow	The motor direction and external encoder installation orientation are backward.	Check the motor direction and the external encoder installation orientation.	Install the external encoder in the opposite direction, or change the setting of Pn002 (2002h) = n.X□□□ (External Encoder Usage) to reverse the direction.	*1
	There is an error in the connection between the load (e.g., stage) and external encoder coupling.	Check the coupling of the external encoder.	Check the mechanical coupling.	–
E00h: EtherCAT Module Interface Initialization Timeout Error	A failure occurred in the SERVOPACK.	–	Replace the SERVOPACK.	–
E02h: EtherCAT Internal Synchronization Error 1	The EtherCAT transmission cycle fluctuated.	–	Remove the cause of transmission cycle fluctuation at the host controller.	–
	A failure occurred in the SERVOPACK.	–	Turn the power supply to the SERVOPACK OFF and ON again. If the alarm still occurs, the SERVOPACK may be faulty. Replace the SERVOPACK.	–
E03h: EtherCAT Module Interface Communications Data Error	Noise caused an error in communications between the SERVOPACK and EtherCAT Network Module.	–	Implement countermeasures against noise.	–
	A failure occurred in the SERVOPACK.	–	Replace the SERVOPACK.	–

Continued on next page.

Continued from previous page.

Alarm Code: Alarm Name	Possible Cause	Confirmation	Correction	Reference
E72h: Feedback Option Module Detection Failure	There is a faulty connection between the SERVOPACK and the Feedback Option Module.	Check the connection between the SERVOPACK and the Feedback Option Module.	Correctly connect the Feedback Option Module.	–
	The Feedback Option Module was disconnected.	–	Reset the Option Module configuration error and turn the power supply to the SERVOPACK OFF and ON again.	*1
	A failure occurred in the Feedback Option Module.	–	Replace the Feedback Option Module.	–
	A failure occurred in the SERVOPACK.	–	Replace the SERVOPACK.	–
E75h: Unsupported Feedback Option Module Alarm	A failure occurred in the Feedback Option Module.	–	Replace the Feedback Option Module.	–
	An unsupported Feedback Option Module was connected.	Refer to the catalog for the connected Feedback Option Module or the SERVOPACK manual.	Connect a supported Feedback Option Module.	–
EA0h: Command- Option IF Servo Unit Initial Error	A failure occurred in the SERVOPACK.	–	Replace the SERVOPACK.	–
EA1h: Command- Option IF Mem- ory Check Error	A failure occurred in the SERVOPACK.	–	Replace the SERVOPACK.	–
EA2h: Command- Option IF Servo Synchronization Error	Fluctuation in the EtherCAT communications synchronization timing (Sync0) caused the synchronization timing in the SERVOPACK to fluctuate.	–	Turn the power supply OFF and ON again and re-establish communications.	–
	A failure occurred in the SERVOPACK.	–	Repair or replace the SERVOPACK.	–
EA3h: Command- Option IF Servo Data Error	Noise caused an error in communications in the SERVOPACK.	–	Implement countermeasures against noise.	–
	A failure occurred in the SERVOPACK.	–	Replace the SERVOPACK.	–
Eb1h: Safety Function Signal Input Tim- ing Error	The delay between activation of the /HWBB1 and /HWBB2 input signals for the HWBB was ten second or longer.	Measure the time delay between the /HWBB1 and /HWBB2 signals.	The output signal circuits or devices for /HWBB1 and /HWBB2 or the SERVOPACK input signal circuits may be faulty. Alternatively, the input signal cables may be disconnected. Check to see if any of these items are faulty or have been disconnected.	–
	A failure occurred in the SERVOPACK.	–	Replace the SERVOPACK.	–

Continued on next page.

3.1 Alarm Displays

3.1.2 Troubleshooting Alarms

Continued from previous page.

Alarm Code: Alarm Name	Possible Cause	Confirmation	Correction	Reference
EC8h: Gate Drive Error 1 (An error occurred in the gate drive circuit.)	A failure occurred in the SERVOPACK.	-	Turn the power supply to the SERVOPACK OFF and ON again. If the alarm still occurs, the SERVOPACK may be faulty. Replace the SERVOPACK.	-
EC9h: Gate Drive Error 2 (An error occurred in the gate drive circuit.)				
Ed1h: Command Execution Timeout	A timeout error occurred for an Ether-CAT command.	Check the Servomotor status when the command is executed.	Execute the Servo ON command (Enable Operation command) only when the Servomotor is not operating.	-
F10h: Power Supply Line Open Phase (The voltage was low for more than one second for phase R, S, or T when the main power supply was ON.)	The three-phase power supply wiring is not correct.	Check the power supply wiring.	Make sure that the power supply is correctly wired.	*1
	The three-phase power supply is unbalanced.	Measure the voltage for each phase of the three-phase power supply.	Balance the power supply by changing phases.	-
	A failure occurred in the SERVOPACK.	-	Turn the power supply to the SERVOPACK OFF and ON again. If the alarm still occurs, the SERVOPACK may be faulty. Replace the SERVOPACK.	-
FL-1: ^{*5} System Alarm	A failure occurred in the SERVOPACK.	-	Turn the power supply to the SERVOPACK OFF and ON again. If the alarm still occurs, the SERVOPACK may be faulty. Replace the SERVOPACK.	-
FL-2: ^{*5} System Alarm				
FL-3: ^{*5} System Alarm				
FL-4: ^{*5} System Alarm				
FL-5: ^{*5} System Alarm				
FL-6: ^{*5} System Alarm				
CPF00: Digital Operator Communications Error 1	There is a faulty connection between the Digital Operator and the SERVOPACK.	Check the connector contact.	Disconnect the connector and insert it again. Or, replace the cable.	-
	A malfunction was caused by noise.	-	Keep the Digital Operator or the cable away from sources of noise.	-

Continued on next page.

Continued from previous page.

Alarm Code: Alarm Name	Possible Cause	Confirmation	Correction	Reference
CPF01: Digital Operator Communications Error 2	A failure occurred in the Digital Operator.	—	Disconnect the Digital Operator and then connect it again. If the alarm still occurs, the Digital Operator may be faulty. Replace the Digital Operator.	—
	A failure occurred in the SERVOPACK.	—	Turn the power supply to the SERVOPACK OFF and ON again. If the alarm still occurs, the SERVOPACK may be faulty. Replace the SERVOPACK.	—

*1. Refer to the following manual for details.

 Σ -7-Series Σ -7S SERVOPACK with EtherCAT (CoE) Communications References Product Manual (Manual No.: SIEP S800001 55)

*2. Detection Conditions

If either of the following conditions is detected, an alarm will occur.

$$\bullet \text{ Pn533 [min}^{-1}\text{]} \times \frac{\text{Encoder resolution}}{6 \times 10^5} \leq \frac{\text{Pn20E}}{\text{Pn210}}$$

$$\bullet \text{ Maximum motor speed [min}^{-1}\text{]} \times \frac{\text{Encoder resolution}}{\text{Approx. } 3.66 \times 10^{12}} \geq \frac{\text{Pn20E}}{\text{Pn210}}$$

*3. For details, refer to the following manual.

 Σ -7-Series Peripheral Device Selection Manual (Manual.No.: SIEP S800001 32)

*4. The SERVOPACK will fail if the External Regenerative Resistor or Regenerative Resistor Unit is connected while the jumper is connected between the B2 and B3 terminals.

*5. These alarms are not stored in the alarm history. They are only displayed on the panel display.

3.2 Warning Displays

To check a warning that occurs in the SERVOPACK, use one of the following methods. Warnings are displayed to warn you before an alarm occurs.

Panel display on SERVOPACK	<p>If there is a warning, the code will be displayed one character at a time, as shown below. Example: Alarm A.910</p>
Digital Operator	The warning code is displayed.
Statusword (6041h)	Bit 7 (<i>warning</i>) in the <i>statusword</i> will change to 1. (Bit 7 is 0 during normal operation.)
Error code (603Fh)	A current warning code is stored in <i>error code</i> (603Fh).
Emergency message	The Controller is notified of any warning that occurs. (Notification may not be possible if EtherCAT communications are unstable.)

This next section provides a list of warnings and the causes of and corrections for warnings.

3.2.1 List of Warnings

The warning table gives the warning name and warning meaning in order of the warning codes.

Warning Code	Warning Name	Meaning
900h	Position Deviation Overflow	The position deviation exceeded the percentage set with the following formula: $(Pn520 (2520h) \times Pn51E (251Eh)/100)$
901h	Position Deviation Overflow Alarm at Servo ON	The position deviation when the servo was turned ON exceeded the percentage set with the following formula: $(Pn526 (2526h) \times Pn528 (2528h)/100)$
910h	Overload	This warning occurs before an overload alarm (A.710 or A.720) occurs. If the warning is ignored and operation is continued, an alarm may occur.
911h	Vibration	Abnormal vibration was detected during motor operation. The detection level is the same as A.520. Set whether to output an alarm or a warning by setting Pn310 (2310h) (Vibration Detection Switch).
912h	Internal Temperature Warning 1 (Control Board Temperature Error)	The surrounding temperature of the control PCB is abnormal.
913h	Internal Temperature Warning 2 (Power Board Temperature Error)	The surrounding temperature of the power PCB is abnormal.
920h	Regenerative Overload	This warning occurs before an A.320 alarm (Regenerative Overload) occurs. If the warning is ignored and operation is continued, an alarm may occur.
921h	Dynamic Brake Overload	This warning occurs before an A.731 alarm (Dynamic Brake Overload) occurs. If the warning is ignored and operation is continued, an alarm may occur.
923h	SERVOPACK Built-in Fan Stopped	The fan inside the SERVOPACK stopped.
930h	Absolute Encoder Battery Error	This warning occurs when the voltage of absolute encoder's battery is low.

Continued on next page.

Continued from previous page.

Warning Code	Warning Name	Meaning
942h	Speed Ripple Compensation Information Disagreement	The speed ripple compensation information stored in the encoder does not agree with the speed ripple compensation information stored in the SERVOPACK.
971h	Undervoltage	This warning occurs before an A.410 alarm (Undervoltage) occurs. If the warning is ignored and operation is continued, an alarm may occur.
9A0h	Overtravel	Overtravel was detected while the servo was ON.
9b0h	Preventative Maintenance Warning	One of the consumable parts has reached the end of its service life.

Note: Use Pn008 (2008h) = n.□X□□ (Warning Detection Selection) to control warning detection. However, the following warnings are not affected by the setting of Pn008 (2008h) = n.□X□□, and other parameter settings are required in addition to Pn008 = n.□X□□.

Warning	Parameters That Must Be Set to Select Warning Detection	Reference
911h	Pn310 (2310h) = n.□□□X (Vibration Detection Selection)	*
930h	Pn008 (2008h) = n.□□□X (Low Battery Voltage Alarm/Warning Selection)	*
942h	Pn423 (2423h) = n.□□X□ (Speed Ripple Compensation Information Disagreement Warning Detection Selection)	*
971h	Pn008 (2008h) = n.□□□X (Low Battery Voltage Alarm/Warning Selection) (Not affected by the setting of Pn008 (2008h) = n.□X□□.)	page 4-3
9A0h	Pn00D (200Dh) = n.X□□□ (Overtravel Warning Detection Selection) (Not affected by the setting of Pn008 (2008h) = n.□X□□.)	*
9b0h	Pn00F (200Fh) = n.□□□X (Preventative Maintenance Warning Selection)	*

* Refer to the following manual for details.

 Σ -7-Series Σ -7S SERVOPACK with EtherCAT (CoE) Communications References Product Manual (Manual No.: S1EP S800001 55)

3.2.2 Troubleshooting Warnings

The causes of and corrections for the warning are given in the following table. Contact your Yaskawa representative if you cannot solve a problem with the correction given in the table.

Warning Number: Warning Name	Possible Cause	Confirmation	Correction	Reference
900h: Position Deviation Overflow	The Servomotor U, V, and W wiring is not correct.	Check the wiring of the Servomotor's Main Circuit Cables.	Make sure that there are no faulty connections in the wiring for the Servomotor and encoder.	–
	A SERVOPACK gain is too low.	Check the SERVO-PACK gains.	Increase the servo gain, e.g., by using autotuning without a host reference.	*
	The acceleration of the position reference is too high.	Reduce the reference acceleration and try operating the SERVO-PACK.	Reduce the acceleration of the position reference using an EtherCAT command.	–
	The excessive position deviation alarm level (Pn520 (2520h) × Pn51E (251Eh)/100) is too low for the operating conditions.	Check excessive position deviation alarm level (Pn520 (2520h) × Pn51E (251Eh)/100) to see if it is set to an appropriate value.	Optimize the settings of Pn520 (2520h) and Pn51E (251Eh).	*
	A failure occurred in the SERVO-PACK.	–	Turn the power supply to the SERVOPACK OFF and ON again. If the alarm still occurs, the SERVOPACK may be faulty. Replace the SERVOPACK.	–
901h: Position Deviation Overflow Alarm at Servo ON	The position deviation when the servo was turned ON exceeded the percentage set with the following formula: (Pn526 (2526h) × Pn528 (2528h)/100)	–	Optimize the setting of Pn528 (2528h) (Excessive Position Error Warning Level at Servo ON).	–

Continued on next page.

Continued from previous page.

Warning Number: Warning Name	Possible Cause	Confirmation	Correction	Reference
910h: Overload (warning before an A.710 or A.720 alarm occurs)	The wiring is not correct or there is a faulty connection in the motor or encoder wiring.	Check the wiring.	Make sure that the Servomotor and encoder are correctly wired.	–
	Operation was performed that exceeded the overload protection characteristics.	Check the motor overload characteristics and Run command.	Consider the following: <ul style="list-style-type: none"> • Reconsider the load and operating conditions. • Select a Servomotor again. 	–
	An excessive load was applied during operation because the Servomotor was not driven because of mechanical problems.	Check the operation reference and motor speed.	Remove the mechanical problem.	–
	The overload warning level (Pn52B (252Bh)) is not suitable.	Check that the overload warning level (Pn52B (252Bh)) is suitable.	Set a suitable overload warning level (Pn52B (252Bh)).	*
	A failure occurred in the SERVOPACK.	–	The SERVOPACK may be faulty. Replace the SERVOPACK.	–
911h: Vibration	Abnormal vibration was detected during Servomotor operation.	Check for abnormal Servomotor noise, and check the speed and torque waveforms during operation.	Reduce the motor speed. Or, reduce the servo gain with custom tuning.	*
	The setting of Pn103 (2103h) (Moment of Inertia Ratio) is greater than the actual moment of inertia or was greatly changed.	Check the moment of inertia ratio or mass ratio.	Correct the setting of Pn103 (2103h).	*
	The vibration detection level (Pn312 (2312h)) is not suitable.	Check that the vibration detection level (Pn312 (2312h)) is suitable.	Set a suitable vibration detection level (Pn312 (2312h)).	*

Continued on next page.

3.2 Warning Displays

3.2.2 Troubleshooting Warnings

Continued from previous page.

Warning Number: Warning Name	Possible Cause	Confirmation	Correction	Reference
912h: Internal Temperature Warning 1 (Control Board Temperature Error)	The surrounding temperature is too high.	Check the surrounding temperature using a thermometer. Or, check the operating status with the SERVOPACK installation environment monitor.	Decrease the surrounding temperature by improving the SERVOPACK installation conditions.	*
	An overload alarm was reset by turning OFF the power supply too many times.	Check the alarm display to see if there is an overload alarm.	Change the method for resetting the alarm.	-
	There was an excessive load or operation was performed that exceeded the regenerative processing capacity.	Use the accumulated load ratio to check the load during operation, and use the regenerative load ratio to check the regenerative processing capacity.	Reconsider the load and operating conditions.	-
	The SERVOPACK installation orientation is not correct or there is insufficient space around the SERVOPACK.	Check the SERVOPACK installation conditions.	Install the SERVOPACK according to specifications.	*
	A failure occurred in the SERVOPACK.	-	The SERVOPACK may be faulty. Replace the SERVOPACK.	-
913h: Internal Temperature Warning 2 (Power Board Temperature Error)	The surrounding temperature is too high.	Check the surrounding temperature using a thermometer. Or, check the operating status with the SERVOPACK installation environment monitor.	Decrease the surrounding temperature by improving the SERVOPACK installation conditions.	*
	An overload alarm was reset by turning OFF the power supply too many times.	Check the alarm display to see if there is an overload alarm.	Change the method for resetting the alarm.	-
	There was an excessive load or operation was performed that exceeded the regenerative processing capacity.	Use the accumulated load ratio to check the load during operation, and use the regenerative load ratio to check the regenerative processing capacity.	Reconsider the load and operating conditions.	-
	The SERVOPACK installation orientation is not correct or there is insufficient space around the SERVOPACK.	Check the SERVOPACK installation conditions.	Install the SERVOPACK according to specifications.	*
	A failure occurred in the SERVOPACK.	-	The SERVOPACK may be faulty. Replace the SERVOPACK.	-

Continued on next page.

Continued from previous page.

Warning Number: Warning Name	Possible Cause	Confirmation	Correction	Reference
920h: Regenerative Overload (warning before an A.320 alarm occurs)	The power supply voltage exceeded the specified range.	Measure the power supply voltage.	Set the power supply voltage within the specified range.	-
	There is insufficient external regenerative resistance, regenerative resistor capacity, or SERVOPACK capacity, or there has been a continuous regeneration state.	Check the operating conditions and capacity again.	Change the regenerative resistance value, regenerative resistance capacity, or SERVOPACK capacity. Recheck the operating conditions.	-
	There was a continuous regeneration state because a negative load was continuously applied.	Check the load applied to the Servomotor during operation.	Reconsider the system including the servo, machine, and operating conditions.	-
921h: Dynamic Brake Overload (warning before an A.731 alarm occurs)	The Servomotor was rotated by an external force.	Check the operation status.	Implement measures to ensure that the Servomotor will not be rotated by an external force.	-
	When the Servomotor was stopped with the dynamic brake, the rotational or linear kinetic energy exceeded the capacity of the dynamic brake resistor.	Check the power consumed by the DB resistor to see how frequently the DB is being used.	Reconsider the following: <ul style="list-style-type: none"> • Reduce the Servomotor command speed. • Decrease the moment of inertia or mass. • Reduce the frequency of stopping with the dynamic brake. 	-
	A failure occurred in the SERVOPACK.	-	The SERVOPACK may be faulty. Replace the SERVOPACK.	-
923h: SERVOPACK Built-in Fan Stopped	The fan inside the SERVOPACK stopped.	Check for foreign matter inside the SERVOPACK.	Remove foreign matter from the SERVOPACK. If the alarm still occurs, the SERVOPACK may be faulty. Replace the SERVOPACK.	-
930h: Absolute Encoder Battery Error (The absolute encoder battery voltage was lower than the specified level.)	The battery connection is faulty or a battery is not connected.	Check the battery connection.	Correct the battery connection.	*
	The battery voltage is lower than the specified value.	Measure the battery voltage.	Replace the battery.	*
	A failure occurred in the SERVOPACK.	-	The SERVOPACK may be faulty. Replace the SERVOPACK.	-

Continued on next page.

3.2 Warning Displays

3.2.2 Troubleshooting Warnings

Continued from previous page.

Warning Number: Warning Name	Possible Cause	Confirmation	Correction	Reference
942h: Speed Ripple Compensation Information Disagreement	The speed ripple compensation information stored in the encoder does not agree with the speed ripple compensation information stored in the SERVOPACK.	–	Set Pn423 (2423h) to n.□□□0 (Disable speed ripple compensation).	–
971h: Undervoltage	For a 200-V SERVOPACK, the AC power supply voltage dropped below 140 V.	Measure the power supply voltage.	Set the power supply voltage within the specified range.	–
	The power supply voltage dropped during operation.	Measure the power supply voltage.	Increase the power supply capacity.	–
	A momentary power interruption occurred.	Measure the power supply voltage.	If you have changed the setting of Pn509 (2509h) (Momentary Power Interruption Hold Time), decrease the setting.	*
	The SERVOPACK fuse is blown out.	–	Replace the SERVOPACK and connect a reactor.	*
9A0h: Overtravel (Overtravel status was detected.)	A failure occurred in the SERVOPACK.	–	The SERVOPACK may be faulty. Replace the SERVOPACK.	–
	Overtravel was detected while the servo was ON.	Check the status of the overtravel signals on the input signal monitor.	Even if an overtravel signal is not shown by the input signal monitor, momentary overtravel may have been detected. Take the following precautions. <ul style="list-style-type: none"> • Do not specify movements that would cause overtravel from the host controller. • Check the wiring of the overtravel signals. • Implement countermeasures against noise. 	*
9b0h: Preventative Maintenance Warning	One of the consumable parts has reached the end of its service life.	–	Replace the part. Contact your Yaskawa representative for replacement.	*

* Refer to the following manual for details.

 Σ-7-Series Σ-7S SERVOPACK with EtherCAT (CoE) Communications References Product Manual (Manual No.: SIEP S800001 55)

3.3 Troubleshooting Based on the Operation and Conditions of the Servomotor

This section provides troubleshooting based on the operation and conditions of the Servomotor, including causes and corrections.

Problem	Possible Cause	Confirmation	Correction	Reference
Servomotor Does Not Start	The control power supply is not turned ON.	Measure the voltage between control power supply terminals.	Turn OFF the power supply to the servo system. Correct the wiring so that the control power supply is turned ON.	-
	The main circuit power supply is not turned ON.	Measure the voltage across the main circuit power input terminals.	Turn OFF the power supply to the servo system. Correct the wiring so that the main circuit power supply is turned ON.	-
	The I/O signal connector (CN1) pins are not wired correctly or are disconnected.	Turn OFF the power supply to the servo system. Check the wiring condition of the I/O signal connector (CN1) pins.	Correct the wiring of the I/O signal connector (CN1) pins.	*1
	The wiring for the Servomotor Main Circuit Cables or Encoder Cable is disconnected.	Check the wiring conditions.	Turn OFF the power supply to the servo system. Wire the cable correctly.	-
	There is an overload on the Servomotor.	Operate the Servomotor with no load and check the load status.	Turn OFF the power supply to the servo system. Reduce the load or replace the Servomotor with a larger capacity.	-
	There is a mistake in the input signal allocations (Pn50A (250Ah), Pn50B (250Bh), Pn511 (2511h), and Pn516 (2516h)).	Check the input signal allocations (Pn50A (250Ah), Pn50B (250Bh), Pn511 (2511h), Pn516 (2516h)).	Correctly allocate the input signals (Pn50A (250Ah), Pn50B (250Bh), Pn511 (2511h), Pn516 (2516h)).	*1
	The Servo ON command (Enable Operation command) was not sent.	Make sure the Servo ON command (Enable Operation command) is set to Operation Enabled.	Set the correct value for the Servo ON command (Enable Operation command).	-
	The torque limit reference is too small.	Check the torque limit reference.	Increase the torque limit reference.	-
	The operation mode is not set.	Check to see if <i>modes of operation</i> (6060h) is set.	Set <i>modes of operation</i> (6060h) correctly.	-
	A software limit is active.	Check to see if the target position exceeds a software limit.	Specify a target position that is within the software limits.	-
EtherCAT communications are not established.	Check to see if the EtherCAT indicator shows the Operational state.	Place the EtherCAT communications in the Operational state.	-	
The P-OT (Forward Drive Prohibit) or N-OT (Reverse Drive Prohibit) signal is still OFF.	Check the P-OT and N-OT signals.	Turn ON the P-OT and N-OT signals.	*1	

Continued on next page.

Continued from previous page.

Problem	Possible Cause	Confirmation	Correction	Reference
Servomotor Does Not Start	The safety input signals (/HWBB1 or /HWBB2) were not turned ON.	Check the /HWBB1 and /HWBB2 input signals.	Turn ON the /HWBB1 and /HWBB2 input signals. If you are not using the safety function, connect the Safety Jumper Connector (provided as an accessory) to CN8.	*1
	The FSTP (Forced Stop Input) signal is still OFF.	Check the FSTP signal.	<ul style="list-style-type: none"> • Turn ON the FSTP signal. • If you will not use the function to force the motor to stop, set Pn516 (2516h) = n.□□□X (FSTP (Forced Stop Input) Signal Allocation) to disable the signal. 	*1
	A failure occurred in the SERVOPACK.	—	Turn OFF the power supply to the servo system. Replace the SERVOPACK.	—
Servomotor Moves Instantaneously, and Then Stops	There is a mistake in the Servomotor wiring.	Turn OFF the power supply to the servo system. Check the wiring.	Wire the Servomotor correctly.	—
	There is a mistake in the encoder wiring.	Turn OFF the power supply to the servo system. Check the wiring.	Wire the cable correctly.	—
Servomotor Operation Is Unstable	There is a faulty connection in the Servomotor wiring.	The connector connections for the power line (U, V, and W phases) and the encoder may be unstable. Turn OFF the power supply to the servo system. Check the wiring.	Tighten any loose terminals or connectors and correct the wiring.	—
Servomotor Moves without a Reference Input	A failure occurred in the SERVOPACK.	—	Turn OFF the power supply to the servo system. Replace the SERVOPACK.	—
Dynamic Brake Does Not Operate	The setting of Pn001 (2001h) = n.□□□X (Servo OFF or Alarm Group 1 Stopping Method) is not suitable.	Check the setting of Pn001 (2001h) = n.□□□X.	Set Pn001 (2001h) = n.□□□X correctly.	—
	The dynamic brake resistor is disconnected.	Check the moment of inertia, motor speed, and dynamic brake frequency of use. If the moment of inertia, motor speed, or dynamic brake frequency of use is excessive, the dynamic brake resistance may be disconnected.	Turn OFF the power supply to the servo system. Replace the SERVOPACK. To prevent disconnection, reduce the load.	—
	There was a failure in the dynamic brake drive circuit.	—	There is a defective component in the dynamic brake circuit. Turn OFF the power supply to the servo system. Replace the SERVOPACK.	—

Continued on next page.

Continued from previous page.

Problem	Possible Cause	Confirmation	Correction	Reference
Abnormal Noise from Servomotor	The Servomotor vibrated considerably while performing the tuning-less function with the default settings.	Check the waveform of the motor speed.	Reduce the load so that the moment of inertia ratio or mass ratio is within the allowable value, or increase the load level or reduce the rigidity level in the tuning-less level settings. If the situation is not improved, disable the tuning-less function (i.e., set Pn170 (2170h) to n.□□□0) and execute autotuning either with or without a host reference.	*1
	The machine mounting is not secure.	Turn OFF the power supply to the servo system. Check the mounting state of the Servomotor.	Tighten the mounting screws.	-
		Turn OFF the power supply to the servo system. Check to see if there is misalignment in the coupling.	Align the coupling.	-
		Turn OFF the power supply to the servo system. Check to see if the coupling is balanced.	Balance the coupling.	-
	The bearings are defective.	Turn OFF the power supply to the servo system. Check for noise and vibration around the bearings.	Replace the Servomotor.	-
There is a vibration source at the driven machine.	Turn OFF the power supply to the servo system. Check for any foreign matter, damage, or deformation in the machine's moving parts.	Consult with the machine manufacturer.	-	

Continued on next page.

Continued from previous page.

Problem	Possible Cause	Confirmation	Correction	Reference
Abnormal Noise from Servomotor	Noise interference occurred because of incorrect I/O signal cable specifications.	Turn OFF the power supply to the servo system. Check the I/O signal cables to see if they satisfy specifications. Use shielded twisted-pair cables or screened twisted-pair cables with conductors of at least 0.12 mm ² (stranded wire).	Use cables that satisfy the specifications.	-
	Noise interference occurred because an I/O signal cable is too long.	Turn OFF the power supply to the servo system. Check the lengths of the I/O signal cables.	The I/O signal cables must be no longer than 3 m.	-
	Noise interference occurred because of incorrect Encoder Cable specifications.	Turn OFF the power supply to the servo system. Check the Encoder Cable to see if it satisfies specifications. Use shielded twisted-pair cables or screened twisted-pair cables with conductors of at least 0.12 mm ² (stranded wire).	Use cables that satisfy the specifications.	-
	Noise interference occurred because the Encoder Cable is too long.	Turn OFF the power supply to the servo system. Check the length of the Encoder Cable.	The Encoder Cable must be no longer than 20 m.	-
	Noise interference occurred because the Encoder Cable is damaged.	Turn OFF the power supply to the servo system. Check the Encoder Cable to see if it is pinched or the sheath is damaged.	Replace the Encoder Cable and correct the cable installation environment.	-
	The Encoder Cable was subjected to excessive noise interference.	Turn OFF the power supply to the servo system. Check to see if the Encoder Cable is bundled with a high-current line or installed near a high-current line.	Correct the cable layout so that no surge is applied by high-current lines.	-
	There is variation in the FG potential because of the influence of machines on the Servomotor side, such as a welder.	Turn OFF the power supply to the servo system. Check to see if the machines are correctly grounded.	Properly ground the machines to separate them from the FG of the encoder.	-
	There is a SERVOPACK pulse counting error due to noise.	Check to see if there is noise interference on the signal line from the encoder.	Turn OFF the power supply to the servo system. Implement countermeasures against noise for the encoder wiring.	-
	The encoder was subjected to excessive vibration or shock.	Turn OFF the power supply to the servo system. Check to see if vibration from the machine occurred. Check the Servomotor installation (mounting surface precision, securing state, and alignment).	Reduce machine vibration. Or, improve the mounting state of the Servomotor.	-
A failure occurred in the encoder.	-	Turn OFF the power supply to the servo system. Replace the Servomotor.	-	

Continued on next page.

Continued from previous page.

Problem	Possible Cause	Confirmation	Correction	Reference
Servomotor Vibrates at Frequency of Approx. 200 Hz to 400 Hz.	The servo gains are not balanced.	Check to see if the servo gains have been correctly tuned.	Perform autotuning without a host reference.	*1
	The setting of Pn100 (2100h) (Speed Loop Gain) is too high.	Check the setting of Pn100 (2100h). The default setting is Kv = 40.0 Hz.	Set Pn100 (2100h) to an appropriate value.	-
	The setting of Pn102 (2102h) (Position Loop Gain) is too high.	Check the setting of Pn102 (2102h). The default setting is Kp = 40.0/s.	Set Pn102 (2102h) to an appropriate value.	-
	The setting of Pn101 (2101h) (Speed Loop Integral Time Constant) is not appropriate.	Check the setting of Pn101 (2101h). The default setting is Ti = 20.0 ms.	Set Pn101 (2101h) to an appropriate value.	-
	The setting of Pn103 (2103h) (Moment of Inertia Ratio or Mass Ratio) is not appropriate.	Check the setting of Pn103 (2103h).	Set Pn103 (2103h) to an appropriate value.	-
Large Motor Speed Overshoot on Starting and Stopping	The servo gains are not balanced.	Check to see if the servo gains have been correctly tuned.	Perform autotuning without a host reference.	*1
	The setting of Pn100 (2100h) (Speed Loop Gain) is too high.	Check the setting of Pn100 (2100h). The default setting is Kv = 40.0 Hz.	Set Pn100 (2100h) to an appropriate value.	-
	The setting of Pn102 (2102h) (Position Loop Gain) is too high.	Check the setting of Pn102 (2102h). The default setting is Kp = 40.0/s.	Set Pn102 (2102h) to an appropriate value.	-
	The setting of Pn101 (2101h) (Speed Loop Integral Time Constant) is not appropriate.	Check the setting of Pn101 (2101h). The default setting is Ti = 20.0 ms.	Set Pn101 (2101h) to an appropriate value.	-
	The setting of Pn103 (2103h) (Moment of Inertia Ratio or Mass Ratio) is not appropriate.	Check the setting of Pn103 (2103h).	Set Pn103 (2103h) to an appropriate value.	-
	The torque reference is saturated.	Check the waveform of the torque reference.	Use the mode switch.	-

Continued on next page.

Continued from previous page.

Problem	Possible Cause	Confirmation	Correction	Reference
Absolute Encoder Position Deviation Error (The position that was saved in the host controller when the power was turned OFF is different from the position when the power was next turned ON.)	Noise interference occurred because of incorrect Encoder Cable specifications.	Turn OFF the power supply to the servo system. Make sure that the rotary or Linear Encoder Cable satisfies the specifications. Use a shielded twisted-pair wire cable or a screened twisted-pair cable with a conductors of at least 0.12 mm ² .	Use cables that satisfy the specifications.	-
	Noise interference occurred because the Encoder Cable is too long.	Turn OFF the power supply to the servo system. Check the length of the Encoder Cable.	The Encoder Cable must be no longer than 20 m.	-
	Noise interference occurred because the Encoder Cable is damaged.	Turn OFF the power supply to the servo system. Check the Encoder Cable to see if it is pinched or the sheath is damaged.	Replace the Encoder Cable and correct the cable installation environment.	-
	The Encoder Cable was subjected to excessive noise interference.	Turn OFF the power supply to the servo system. Check to see if the Encoder Cable is bundled with a high-current line or installed near a high-current line.	Correct the cable layout so that no surge is applied by high-current lines.	-
	There is variation in the FG potential because of the influence of machines on the Servomotor side, such as a welder.	Turn OFF the power supply to the servo system. Check to see if the machines are correctly grounded.	Properly ground the machines to separate them from the FG of the encoder.	-
	There is a SERVOPACK pulse counting error due to noise.	Turn OFF the power supply to the servo system. Check to see if there is noise interference on the signal line from the encoder.	Implement countermeasures against noise for the encoder wiring.	-
	The encoder was subjected to excessive vibration or shock.	Turn OFF the power supply to the servo system. Check to see if vibration from the machine occurred. Check the Servomotor installation (mounting surface precision, securing state, and alignment).	Reduce machine vibration. Or, improve the mounting state of the Servomotor.	-
	A failure occurred in the encoder.	-	Turn OFF the power supply to the servo system. Consult Harmonic Drive Systems Inc.	-
	A failure occurred in the SERVOPACK.	-	Turn OFF the power supply to the servo system. Replace the Servomotor.	-

Continued on next page.

Continued from previous page.

Problem	Possible Cause	Confirmation	Correction	Reference
Absolute Encoder Position Deviation Error (The position that was saved in the host controller when the power was turned OFF is different from the position when the power was next turned ON.)	Host Controller Multiturn Data or Absolute Encoder Position Data Reading Error	Check the error detection section of the host controller.	Correct the error detection section of the host controller.	-
		Check to see if the host controller is executing data parity checks.	Perform parity checks for the multiturn data or absolute encoder position data.	-
		Check for noise interference in the cable between the SERVO-PACK and the host controller.	Implement countermeasures against noise and then perform parity checks again for the multiturn data or absolute encoder position data.	-
	The multiturn limit settings do not agree between the host controller and Pn205.	Check the multiturn limit settings on the host controller and in Pn205.	Set the same the multiturn limit setting on the host controller and in Pn205.	*
Overtravel Occurred	The P-OT/N-OT (Forward Drive Prohibit or Reverse Drive Prohibit) signal was input.	Check the external power supply (+24 V) voltage for the input signals.	Correct the external power supply (+24 V) voltage for the input signals.	-
		Check the operating condition of the overtravel limit switches.	Make sure that the overtravel limit switches operate correctly.	-
		Check the wiring of the overtravel limit switches.	Correct the wiring of the overtravel limit switches.	*
		Check the settings of the overtravel input signal allocations (Pn50A/ Pn50B).	Set the parameters to correct values.	*
	The P-OT/N-OT (Forward Drive Prohibit or Reverse Drive Prohibit) signal malfunctioned.	Check for fluctuation in the external power supply (+24 V) voltage for the input signals.	Eliminate fluctuation from the external power supply (+24 V) voltage for the input signals.	-
		Check to see if the operation of the overtravel limit switches is unstable.	Stabilize the operating condition of the overtravel limit switches.	-
		Check the wiring of the overtravel limit switches (e.g., check for cable damage and loose screws).	Correct the wiring of the overtravel limit switches.	-
	There is a mistake in the allocation of the P-OT or N-OT (Forward Drive Prohibit or Reverse Drive Prohibit) signal in Pn50A (250Ah) = n.X□□□ or Pn50B (250Bh) = n.□□□X.	Check to see if the P-OT signal is allocated in Pn50A (250Ah) = n.X□□□.	If another signal is allocated in Pn50A (250Ah) = n.X□□□, allocate the P-OT signal instead.	*
		Check to see if the N-OT signal is allocated in Pn50B (250Bh) = n.□□□X.	If another signal is allocated in Pn50B (250Bh) = n.□□□X, allocate the N-OT signal instead.	*
	The selection of the Servomotor stopping method is not correct.	Check the servo OFF stopping method set in Pn001 (2001h) = n.□□□X or Pn001 (2001h) = n.□□X□.	Select a Servomotor stopping method other than coasting to a stop.	*
Check the torque control stopping method set in Pn001 (2001h) = n.□□□X or Pn001 (2001h) = n.□□X□.		Select a Servomotor stopping method other than coasting to a stop.	*	

Continued on next page.

Continued from previous page.

Problem	Possible Cause	Confirmation	Correction	Reference
Improper Stop Position for Overtravel (OT) Signal	The limit switch position and dog length are not appropriate.	–	Install the limit switch at the appropriate position.	–
	The overtravel limit switch position is too close for the coasting distance.	–	Install the overtravel limit switch at the appropriate position.	–
Position Deviation (without Alarm)	Noise interference occurred because of incorrect Encoder Cable specifications.	Turn OFF the power supply to the servo system. Make sure that the rotary or Linear Encoder Cable satisfies the specifications. Use a shielded twisted-pair wire cable or a screened twisted-pair cable with a conductors of at least 0.12 mm ² .	Use cables that satisfy the specifications.	–
	Noise interference occurred because the Encoder Cable is too long.	Turn OFF the power supply to the servo system. Check the length of the Encoder Cable.	The Encoder Cable must be no longer than 20 m.	–
	Noise interference occurred because the Encoder Cable is damaged.	Turn OFF the power supply to the servo system. Check the Encoder Cable to see if it is pinched or the sheath is damaged.	Replace the Encoder Cable and correct the cable installation environment.	–
	The Encoder Cable was subjected to excessive noise interference.	Turn OFF the power supply to the servo system. Check to see if the Encoder Cable is bundled with a high-current line or installed near a high-current line.	Correct the cable layout so that no surge is applied by high-current lines.	–
	There is variation in the FG potential because of the influence of machines on the Servomotor side, such as a welder.	Turn OFF the power supply to the servo system. Check to see if the machines are correctly grounded.	Properly ground the machines to separate them from the FG of the encoder.	–
	The encoder was subjected to excessive vibration or shock.	Turn OFF the power supply to the servo system. Check to see if vibration from the machine occurred. Check the Servomotor installation (mounting surface precision, securing state, and alignment).	Reduce machine vibration. Or, improve the mounting state of the Servomotor.	–
	The coupling between the machine and Servomotor is not suitable.	Turn OFF the power supply to the servo system. Check to see if position offset occurs at the coupling between machine and Servomotor.	Correctly secure the coupling between the machine and Servomotor.	–
	Noise interference occurred because of incorrect I/O signal cable specifications.	Turn OFF the power supply to the servo system. Check the I/O signal cables to see if they satisfy specifications. Use shielded twisted-pair cables or screened twisted-pair cables with conductors of at least 0.12 mm ² (stranded wire).	Use cables that satisfy the specifications.	–

Continued on next page.

Continued from previous page.

Problem	Possible Cause	Confirmation	Correction	Reference
Position Deviation (without Alarm)	Noise interference occurred because an I/O signal cable is too long.	Turn OFF the power supply to the servo system. Check the lengths of the I/O signal cables.	The I/O signal cables must be no longer than 3 m.	-
	An encoder fault occurred. (The pulse count does not change.)	-	Turn OFF the power supply to the servo system. Replace the Servomotor.	-
	A failure occurred in the SERVOPACK.	-	Turn OFF the power supply to the servo system. Replace the Servomotor.	-
Servomotor Overheated	The surrounding air temperature is too high.	Measure the surrounding air temperature around the Servomotor.	Reduce the surrounding air temperature to 40°C or less.	-
	The Servomotor surface is dirty.	Turn OFF the power supply to the servo system. Visually check the surface for dirt.	Clean dirt, dust, and oil from the surface.	-
	There is an overload on the Servomotor.	Check the load status with a monitor.	If there is an overload, reduce the load or select SERVOPACK and Servomotor models with larger capacities.	-

* Refer to the following manual for details.

📖 Σ -7-Series Σ -7S SERVOPACK with EtherCAT (CoE) Communications References Product Manual (Manual No.: SIEP S800001 55)

Parameter and Object Lists

4

This chapter provides information on parameters and objects.

4.1	List of Parameters	4-2
4.1.1	Interpreting the Parameter Lists	4-2
4.1.2	List of Parameters	4-3
4.2	Object List	4-26
4.3	SDO Abort Code List	4-34
4.4	Parameter Recording Table	4-35

4.1 List of Parameters

4.1.1 Interpreting the Parameter Lists

Indicates when a change to the parameter will be effective.

Parameter No.	Size	Name	Setting Range	Setting Unit	Default Setting	When Enabled	Classification	Reference	
Pn000 (2000h)	2	Basic Function Selections 0	0000h to 10B1h	-	0000h	After restart	Setup	-	
	<p>There are the following two classifications.</p> <ul style="list-style-type: none"> • Setup • Tuning <p>Refer to the following manual for details.</p> <p>Σ-7-Series Σ-7S SERVOPACK with EtherCAT (CoE) Communications References Product Manual (Manual No.: SIEP S800001 55)</p>								
	n.□□□X		Rotation Direction Selection						Reference
			0	Use CCW as the forward direction.					*1
			1	Use CW as the forward direction. (Reverse Rotation Mode)					
	n.□□X□		Reserved parameter (Do not change.)						
	n.□X□□		Reserved parameter (Do not change.)						
	n.X□□□		Rotary/Linear Servomotor Startup Selection When Encoder Is Not Connected						Reference
			0	When an encoder is not connected, start as SERVOPACK for Rotary Servomotor.					*1
			1	Reserved setting (Do not use.)					

4.1.2 List of Parameters

The following table lists the parameters.

Note: Do not change the following parameters from their default settings.

- Reserved parameters
- Parameters not given in this manual

Parameter No.	Size	Name	Setting Range	Setting Unit	Default Setting	When Enabled	Classification	Reference	
Pn000 (2000h)	2	Basic Function Selections 0	0000h to 10B1h	–	0000h	After restart	Setup	–	
			Rotation Direction Selection						Reference
	n.□□□X		0	Use CCW as the forward direction.					*1
			1	Use CW as the forward direction. (Reverse Rotation Mode)					
	n.□□X□		Reserved parameter (Do not change.)						
	n.□X□□		Reserved parameter (Do not change.)						
			Rotary/Linear Servomotor Startup Selection When Encoder Is Not Connected						Reference
	n.X□□□		0	When an encoder is not connected, start as SERVOPACK for Rotary Servomotor.					*1
			1	Reserved setting (Do not use.)					
	Pn001 (2001h)	2	Application Function Selections 1	0000h to 1142h	–	0000h	After restart	Setup	–
		Motor Stopping Method for Servo OFF and Group 1 Alarms						Reference	
n.□□□X		0	Stop the motor by applying the dynamic brake.					*1	
		1	Stop the motor by the applying dynamic brake and then release the dynamic brake.						
		2	Coast the motor to a stop without the dynamic brake.						
		Overtravel Stopping Method						Reference	
n.□□X□		0	Apply the dynamic brake or coast the motor to a stop.					*1	
		1	Decelerate the motor to a stop using the torque set in Pn406 as the maximum torque and then servo-lock the motor.						
		2	Decelerate the motor to a stop using the torque set in Pn406 as the maximum torque and then let the motor coast.						
		3	Decelerate the motor to a stop using the deceleration time set in Pn30A and then servo-lock the motor.						
		4	Decelerate the motor to a stop using the deceleration time set in Pn30A and then let the motor coast.						
		Main Circuit Power Supply AC/DC Input Selection						Reference	
n.□X□□		0	Input AC power as the main circuit power supply using the L1, L2, and L3 terminals (do not use shared converter).					*1	
		1	Input DC power as the main circuit power supply using the B1/⊕ and ⊖ 2 terminals or the B1 and ⊖ 2 terminals (use an external converter or the shared converter).						
n.X□□□		Reserved parameter (Do not change.)							

Continued on next page.

4.1 List of Parameters

4.1.2 List of Parameters

Continued from previous page.

Parameter No.	Size	Name	Setting Range	Setting Unit	Default Setting	When Enabled	Classification	Reference	
Pn002 (2002h)	2	Application Function Selections 2	0000h to 4213h	–	0001h	After restart	Setup	–	
	n.□□□X	EtherCAT (CoE) Module Torque Limit Command Usage Selection						Reference	
		0	Reserved setting (Do not use.)						–
		1	Enable torque limit commands from EtherCAT (CoE). (Automatically set by the EtherCAT (CoE) Module.)						
		2	Reserved setting (Do not use.)						
	3	Reserved setting (Do not use.)							
	n.□□X□	EtherCAT (CoE) Module Speed Limit Command Usage Selection						Reference	
		0	Disable speed limit commands from EtherCAT (CoE) during torque control.						–
	1	Reserved setting (Do not use.)							
	n.□X□□	Encoder Usage						Reference	
		0	Use the encoder according to encoder specifications.						*1
		1	Use the encoder as an incremental encoder.						
	2	Use the encoder as a single-turn absolute encoder.							
	n.X□□□	External Encoder Usage						Reference	
		0	Do not use an external encoder.						*1
		1	The external encoder moves in the forward direction for CCW motor rotation.						
		2	Reserved setting (Do not use.)						
		3	The external encoder moves in the reverse direction for CCW motor rotation.						
	4	Reserved setting (Do not use.)							

Continued on next page.

Continued from previous page.

Parameter No.	Size	Name	Setting Range	Setting Unit	Default Setting	When Enabled	Classification	Reference	
Pn006 (2006h)	2	Application Function Selections 6	0000h to 105Fh	–	0002h	Immediately	Setup	*1	
	n.□□XX	Analog Monitor 1 Signal Selection							
		00	Motor speed (1 V/1,000 min ⁻¹)						
		01	Speed reference (1 V/1,000 min ⁻¹)						
		02	Torque reference (1 V/100% rated torque)						
		03	Position deviation (0.05 V/reference unit)						
		04	Position amplifier deviation (after electronic gear) (0.05 V/encoder pulse unit)						
		05	Position reference speed (1 V/1,000 min ⁻¹)						
		06	Reserved setting (Do not use.)						
		07	Load-motor position deviation (0.01 V/reference unit)						
		08	Positioning completion (positioning completed: 5 V, positioning not completed: 0 V)						
		09	Speed feedforward (1 V/1,000 min ⁻¹)						
		0A	Torque feedforward (1 V/100% rated torque)						
		0B	Active gain (1st gain: 1 V, 2nd gain: 2 V)						
		0C	Completion of position reference distribution (completed: 5 V, not completed: 0 V)						
		0D	External encoder speed (1 V/1,000 min ⁻¹ : value at the motor shaft)						
		0E	Reserved setting (Do not use.)						
		0F	Reserved setting (Do not use.)						
	10	Main circuit DC voltage							
	11 to 5F	Reserved settings (Do not use.)							
	n.□X□□	Reserved parameter (Do not change.)							
n.X□□□	Reserved parameter (Do not change.)								

Continued on next page.

4.1 List of Parameters

4.1.2 List of Parameters

Continued from previous page.

Parameter No.	Size	Name	Setting Range	Setting Unit	Default Setting	When Enabled	Classification	Reference	
Pn007 (2007h)	2	Application Function Selections 7	0000h to 105Fh	-	0000h	Immediately	Setup	*1	
	n.□□XX	Analog Monitor 2 Signal Selection		00	Motor speed (1 V/1,000 min ⁻¹)				
		01	Speed reference (1 V/1,000 min ⁻¹)						
		02	Torque reference (1 V/100% rated torque)						
		03	Position deviation (0.05 V/reference unit)						
		04	Position amplifier deviation (after electronic gear) (0.05 V/encoder pulse unit)						
		05	Position reference speed (1 V/1,000 min ⁻¹)						
		06	Reserved setting (Do not use.)						
		07	Load-motor position deviation (0.01 V/reference unit)						
		08	Positioning completion (positioning completed: 5 V, positioning not completed: 0 V)						
		09	Speed feedforward (1 V/1,000 min ⁻¹)						
		0A	Torque feedforward (1 V/100% rated torque)						
		0B	Active gain (1st gain: 1 V, 2nd gain: 2 V)						
		0C	Completion of position reference distribution (completed: 5 V, not completed: 0 V)						
		0D	External encoder speed (1 V/1,000 min ⁻¹ : value at the motor shaft)						
		0E	Reserved setting (Do not use.)						
		0F	Reserved setting (Do not use.)						
		10	Main circuit DC voltage						
	11 to 5F	Reserved settings (Do not use.)							
	n.□X□□	Reserved parameter (Do not change.)							
n.X□□□	Reserved parameter (Do not change.)								
Pn008 (2008h)	2	Application Function Selections 8	0000h to 7121h	-	4000h	After restart	Setup	-	
	n.□□□X	Low Battery Voltage Alarm/Warning Selection		0	Output alarm (A.830) for low battery voltage.			*1	
		1	Output warning (A.930) for low battery voltage.						
		Function Selection for Undervoltage							
	n.□□X□	0	Do not detect undervoltage.			*1			
		1	Detect undervoltage warning and limit torque at host controller.						
		2	Detect undervoltage warning and limit torque with Pn424 (2424h) and Pn425 (2425h) (i.e., only in the SERVOPACK).						
	n.□X□□	Warning Detection Selection		0	Detect warnings.			*1	
		1	Do not detect warnings except for A.971.						
		Reserved parameter (Do not change.)							

Continued on next page.

Continued from previous page.

Parameter No.	Size	Name	Setting Range	Setting Unit	Default Setting	When Enabled	Classification	Reference	
Pn009 (2009h)	2	Application Function Selections 9	0000h to 0121h	–	0010h	After restart	Tuning	–	
	n.□□□X		Reserved parameter (Do not change.)						
	n.□□□X	Current Control Mode Selection							Reference
		0	Use current control mode 1.						*1
		1	<ul style="list-style-type: none"> SERVOPACK Models SGD7S-R70A, -R90A, -1R6A, -2R8A, -3R8A, -5R5A, and -7R6A: Use current control mode 1. SERVOPACK Models SGD7S-120A, -180A, -200A, -330A, -470A, -550A, -590A, and -780A: Use current control mode 2. 						
	2	Use current control mode 2.							
	n.□X□□	Speed Detection Method Selection							Reference
		0	Use speed detection 1.						*1
	1	Use speed detection 2.							
	n.X□□□		Reserved parameter (Do not change.)						
Pn00A (200Ah)	2	Application Function Selections A	0000h to 1244h	–	0001h	After restart	Setup	–	
	n.□□□X	Motor Stopping Method for Group 2 Alarms							Reference
		0	Apply the dynamic brake or coast the motor to a stop (use the stopping method set in Pn001 (2001h) = n.□□□X).						*1
		1	Decelerate the motor to a stop using the torque set in Pn406 (2406h) as the maximum torque. Use the setting of Pn001 (2001h) = n.□□□X for the status after stopping.						
		2	Decelerate the motor to a stop using the torque set in Pn406 (2406h) as the maximum torque and then let the motor coast.						
		3	Decelerate the motor to a stop using the deceleration time set in Pn30A (230Ah). Use the setting of Pn001 (2001h) = n.□□□X for the status after stopping.						
	4	Decelerate the motor to a stop using the deceleration time set in Pn30A (230Ah) and then let the motor coast.							
	n.□□□X	Stopping Method for Forced Stops							Reference
		0	Apply the dynamic brake or coast the motor to a stop (use the stopping method set in Pn001 (2001h) = n.□□□X).						*1
		1	Decelerate the motor to a stop using the torque set in Pn406 (2406h) as the maximum torque. Use the setting of Pn001 (2001h) = n.□□□X for the status after stopping.						
		2	Decelerate the motor to a stop using the torque set in Pn406 (2406h) as the maximum torque and then let the motor coast.						
		3	Decelerate the motor to a stop using the deceleration time set in Pn30A (230Ah). Use the setting of Pn001 (2001h) = n.□□□X for the status after stopping.						
	4	Decelerate the motor to a stop using the deceleration time set in Pn30A (230Ah) and then let the motor coast.							
	n.□X□□		Reserved parameter (Do not change.)						
	n.X□□□		Reserved parameter (Do not change.)						

Continued on next page.

4.1 List of Parameters

4.1.2 List of Parameters

Continued from previous page.

Parameter No.	Size	Name	Setting Range	Setting Unit	Default Setting	When Enabled	Classification	Reference	
Pn00B (200Bh)	2	Application Function Selections B	0000h to 1121h	-	0000h	After restart	Setup	-	
	n.□□□X	Operator Parameter Display Selection						Reference	
		0	Display only setup parameters.						*1
		1	Display all parameters.						
	n.□□X□	Motor Stopping Method for Group 2 Alarms						Reference	
		0	Stop the motor by setting the speed reference to 0.						*1
		1	Apply the dynamic brake or coast the motor to a stop (use the stopping method set in Pn001 (2001h) = n.□□□X).						
	2	Set the stopping method with Pn00A (200Ah) = n.□□□X.							
	n.□X□□	Power Input Selection for Three-phase SERVOPACK						Reference	
		0	Use a three-phase power supply input.						*1
1	Use a three-phase power supply input and as a single-phase power supply input.								
n.X□□□	Reserved parameter (Do not change.)								
Pn00C (200Ch)	2	Application Function Selections C	0000h to 0131h	-	0000h	After restart	Setup	*1	
	n.□□□X	Function Selection for Test without a Motor							
		0	Disable tests without a motor.						
	1	Enable tests without a motor.							
	n.□□X□	Encoder Resolution for Tests without a Motor							
		0	Use 13 bits.						
		1	Use 20 bits.						
		2	Use 22 bits.						
	3	Use 24 bits.							
	n.□X□□	Encoder Type Selection for Tests without a Motor							
0		Use an incremental encoder.							
1	Use an absolute encoder.								
n.X□□□	Reserved parameter (Do not change.)								
Pn00D (200Dh)	2	Application Function Selections D	0000h to 1001h	-	0000h	Immediately	Setup	*1	
	n.□□□X	Reserved parameter (Do not change.)							
	n.□□X□	Reserved parameter (Do not change.)							
	n.□X□□	Reserved parameter (Do not change.)							
	n.X□□□	Overtravel Warning Detection Selection							
		0	Do not detect overtravel warnings.						
1	Detect overtravel warnings.								

Continued on next page.

Continued from previous page.

Parameter No.	Size	Name	Setting Range	Setting Unit	Default Setting	When Enabled	Classification	Reference	
Pn00F (200Fh)	2	Application Function Selections F	0000h to 2011h	–	0000h	After restart	Setup	–	
	n.□□□X	Preventative Maintenance Warning Selection						Reference	
		0	Do not detect preventative maintenance warnings.						*1
		1	Detect preventative maintenance warnings.						
	n.□□X□	Reserved parameter (Do not change.)							
	n.□X□□	Reserved parameter (Do not change.)							
n.X□□□	Reserved parameter (Do not change.)								
Pn021 (2021h)	2	Reserved parameter (Do not change.)	–	–	0000h	–	–	–	
Pn022 (2022h)	2	Application Function Selections 22	0000h to 0011h	–	0000h	After restart	Setup	–	
	n.□□□X	Overtravel Release Method Selection						Reference	
		0	Overtravel exists while the P-OT or N-OT signal is being input.						*1
		1	Overtravel exists while the P-OT or N-OT signal is input and the current position of the workpiece is separated from the P-OT signal or N-OT signal.						
	n.□□X□	Reserved parameter (Do not change.)							
	n.□X□□	Reserved parameter (Do not change.)							
n.X□□□	Reserved parameter (Do not change.)								
Pn040 (2040h)	2	Reserved parameter (Do not change.)	–	–	0000h	–	–	–	
Pn081 (2081h)	2	Application Function Selections 81	0000h to 1111h	–	0000h	After restart	Setup	*1	
	n.□□□X	Phase-C Pulse Output Selection							
		0	Output phase-C pulses only in the forward direction.						
		1	Output phase-C pulses in both the forward and reverse directions.						
	n.□□X□	Reserved parameter (Do not change.)							
	n.□X□□	Reserved parameter (Do not change.)							
n.X□□□	Reserved parameter (Do not change.)								
Pn100 (2100h)	2	Speed Loop Gain	10 to 20,000	0.1 Hz	400	Immediately	Tuning	*1	
Pn101 (2101h)	2	Speed Loop Integral Time Constant	15 to 51,200	0.01 ms	2000	Immediately	Tuning	*1	
Pn102 (2102h)	2	Position Loop Gain	10 to 20,000	0.1/s	400	Immediately	Tuning	*1	
Pn103 (2103h)	2	Moment of Inertia Ratio	0 to 20,000	1%	100	Immediately	Tuning	*1	
Pn104 (2104h)	2	Second Speed Loop Gain	10 to 20,000	0.1 Hz	400	Immediately	Tuning	*1	
Pn105 (2105h)	2	Second Speed Loop Integral Time Constant	15 to 51,200	0.01 ms	2000	Immediately	Tuning	*1	
Pn106 (2106h)	2	Second Position Loop Gain	10 to 20,000	0.1/s	400	Immediately	Tuning	*1	

Continued on next page.

4.1 List of Parameters

4.1.2 List of Parameters

Continued from previous page.

Parameter No.	Size	Name	Setting Range	Setting Unit	Default Setting	When Enabled	Classification	Reference
Pn109 (2109h)	2	Feedforward	0 to 100	1%	0	Immediately	Tuning	*1
Pn10A (210Ah)	2	Feedforward Filter Time Constant	0 to 6,400	0.01 ms	0	Immediately	Tuning	*1
Pn10B (210Bh)	2	Gain Application Selections	0000h to 5334h	–	0000h	–	Setup	–
	n.□□□X	Mode Switching Selection					When Enabled	Reference
		0	Use the internal torque reference as the condition (level setting: Pn10C (210Ch)).				Immediately	*1
		1	Use the speed reference as the condition (level setting: Pn10D (210Dh)).					
		2	Use the acceleration reference as the condition (level setting: Pn10E (210Eh)).					
		3	Use the position deviation as the condition (level setting: Pn10F (210Fh)).					
	4	Do not use mode switching.						
	n.□□X□	Speed Loop Control Method					When Enabled	Reference
		0	PI control				After restart	*1
		1	I-P control					
2 and 3		Reserved settings (Do not use.)						
n.□X□□	Reserved parameter (Do not change.)							
n.X□□□	Reserved parameter (Do not change.)							
Pn10C (210Ch)	2	Mode Switching Level for Torque Reference	0 to 800	1%	200	Immediately	Tuning	*1
Pn10D (210Dh)	2	Mode Switching Level for Speed Reference	0 to 10,000	1 min ⁻¹	0	Immediately	Tuning	*1
Pn10E (210Eh)	2	Mode Switching Level for Acceleration	0 to 30,000	1 min ⁻¹ /s	0	Immediately	Tuning	*1
Pn10F (210Fh)	2	Mode Switching Level for Position Deviation	0 to 10,000	1 reference unit	0	Immediately	Tuning	*1
Pn11F (211Fh)	2	Position Integral Time Constant	0 to 50,000	0.1 ms	0	Immediately	Tuning	*1
Pn121 (2121h)	2	Friction Compensation Gain	10 to 1,000	1%	100	Immediately	Tuning	*1
Pn122 (2122h)	2	Second Friction Compensation Gain	10 to 1,000	1%	100	Immediately	Tuning	*1
Pn123 (2123h)	2	Friction Compensation Coefficient	0 to 100	1%	0	Immediately	Tuning	*1
Pn124 (2124h)	2	Friction Compensation Frequency Correction	-10,000 to 10,000	0.1 Hz	0	Immediately	Tuning	*1
Pn125 (2125h)	2	Friction Compensation Gain Correction	1 to 1,000	1%	100	Immediately	Tuning	*1
Pn131 (2131h)	2	Gain Switching Time 1	0 to 65,535	1 ms	0	Immediately	Tuning	*1
Pn132 (2132h)	2	Gain Switching Time 2	0 to 65,535	1 ms	0	Immediately	Tuning	*1
Pn135 (2135h)	2	Gain Switching Waiting Time 1	0 to 65,535	1 ms	0	Immediately	Tuning	*1
Pn136 (2136h)	2	Gain Switching Waiting Time 2	0 to 65,535	1 ms	0	Immediately	Tuning	*1

Continued on next page.

Continued from previous page.

Parameter No.	Size	Name	Setting Range	Setting Unit	Default Setting	When Enabled	Classification	Reference
Pn139 (2139h)	2	Automatic Gain Switching Selections 1	0000h to 0052h	–	0000h	Immediately	Tuning	*1
	n.□□□X	Gain Switching Selection		0	Disable automatic gain switching.			
				1	Reserved setting (Do not use.)			
				2	Use automatic gain switching pattern 1. The gain settings 1 switch automatically to 2 when switching condition A is satisfied. The gain settings 2 switch automatically to 1 when switching condition A is not satisfied.			
	n.□□X□	Gain Switching Condition A		0	/COIN (Positioning Completion Output) signal turns ON.			
				1	/COIN (Positioning Completion Output) signal turns OFF.			
				2	/NEAR (Near Output) signal turns ON.			
				3	/NEAR (Near Output) signal turns OFF.			
				4	Position reference filter output is 0 and position reference input is OFF.			
				5	Position reference input is ON.			
n.□X□□	Reserved parameter (Do not change.)							
n.X□□□	Reserved parameter (Do not change.)							
Pn13D (213Dh)	2	Current Gain Level	100 to 2,000	1%	2000	Immediately	Tuning	*1
Pn140 (2140h)	2	Model Following Control-Related Selections	0000h to 1121h	–	0100h	Immediately	Tuning	*1
	n.□□□X	Model Following Control Selection		0	Do not use model following control.			
				1	Use model following control.			
	n.□□X□	Vibration Suppression Selection		0	Do not perform vibration suppression.			
				1	Perform vibration suppression for a specific frequency.			
				2	Perform vibration suppression for two specific frequencies.			
	n.□X□□	Vibration Suppression Adjustment Selection		0	Do not adjust vibration suppression automatically during execution of autotuning without a host reference, autotuning with a host reference, and custom tuning.			
				1	Adjust vibration suppression automatically during execution of autotuning without a host reference, autotuning with a host reference, and custom tuning.			
	n.X□□□	Speed Feedforward (VFF)/Torque Feedforward (TFF) Selection		0	Do not use model following control and speed/torque feedforward together.			
				1	Use model following control and speed/torque feedforward together.			
Pn141 (2141h)	2	Model Following Control Gain	10 to 20,000	0.1/s	500	Immediately	Tuning	*1
Pn142 (2142h)	2	Model Following Control Gain Correction	500 to 2,000	0.1%	1000	Immediately	Tuning	*1
Pn143 (2143h)	2	Model Following Control Bias in the Forward Direction	0 to 10,000	0.1%	1000	Immediately	Tuning	*1
Pn144 (2144h)	2	Model Following Control Bias in the Reverse Direction	0 to 10,000	0.1%	1000	Immediately	Tuning	*1
Pn145 (2145h)	2	Vibration Suppression 1 Frequency A	10 to 2,500	0.1 Hz	500	Immediately	Tuning	*1

Continued on next page.

4.1 List of Parameters

4.1.2 List of Parameters

Continued from previous page.

Parameter No.	Size	Name	Setting Range	Setting Unit	Default Setting	When Enabled	Classification	Reference	
Pn146 (2146h)	2	Vibration Suppression 1 Frequency B	10 to 2,500	0.1 Hz	700	Immediately	Tuning	*1	
Pn147 (2147h)	2	Model Following Control Speed Feedforward Compensation	0 to 10,000	0.1%	1000	Immediately	Tuning	*1	
Pn148 (2148h)	2	Second Model Following Control Gain	10 to 20,000	0.1/s	500	Immediately	Tuning	*1	
Pn149 (2149h)	2	Second Model Following Control Gain Correction	500 to 2,000	0.1%	1000	Immediately	Tuning	*1	
Pn14A (214Ah)	2	Vibration Suppression 2 Frequency	10 to 2,000	0.1 Hz	800	Immediately	Tuning	*1	
Pn14B (214Bh)	2	Vibration Suppression 2 Correction	10 to 1,000	1%	100	Immediately	Tuning	*1	
Pn14F (214Fh)	2	Control-Related Selections	0000h to 0021h	-	0021h	After restart	Tuning	-	
	n.□□□X		Model Following Control Type Selection					Reference	
			0	Use model following control type 1.					*1
			1	Use model following control type 2.					
	n.□□X□		Tuning-less Type Selection					Reference	
			0	Use tuning-less type 1.					*1
		1	Use tuning-less type 2.						
		2	Use tuning-less type 3.						
n.□X□□		Reserved parameter (Do not change.)							
n.X□□□		Reserved parameter (Do not change.)							
Pn160 (2160h)	2	Anti-Resonance Control-Related Selections	0000h to 0011h	-	0010h	Immediately	Tuning	-	
	n.□□□X		Anti-Resonance Control Selection					Reference	
			0	Do not use anti-resonance control.					*1
			1	Use anti-resonance control.					
	n.□□X□		Anti-Resonance Control Adjustment Selection					Reference	
			0	Do not adjust anti-resonance control automatically during execution of autotuning without a host reference, autotuning with a host reference, and custom tuning.					*1
		1	Adjust anti-resonance control automatically during execution of autotuning without a host reference, autotuning with a host reference, and custom tuning.						
n.□X□□		Reserved parameter (Do not change.)							
n.X□□□		Reserved parameter (Do not change.)							
Pn161 (2161h)	2	Anti-Resonance Frequency	10 to 20,000	0.1 Hz	1000	Immediately	Tuning	*1	
Pn162 (2162h)	2	Anti-Resonance Gain Correction	1 to 1,000	1%	100	Immediately	Tuning	*1	
Pn163 (2163h)	2	Anti-Resonance Damping Gain	0 to 300	1%	0	Immediately	Tuning	*1	
Pn164 (2164h)	2	Anti-Resonance Filter Time Constant 1 Correction	-1,000 to 1,000	0.01 ms	0	Immediately	Tuning	*1	
Pn165 (2165h)	2	Anti-Resonance Filter Time Constant 2 Correction	-1,000 to 1,000	0.01 ms	0	Immediately	Tuning	*1	
Pn166 (2166h)	2	Anti-Resonance Damping Gain 2	0 to 1,000	1%	0	Immediately	Tuning	*1	

Continued on next page.

Continued from previous page.

Parameter No.	Size	Name	Setting Range	Setting Unit	Default Setting	When Enabled	Classification	Reference	
Pn170 (2170h)	2	Tuning-less Function-Related Selections	0000h to 2711h	–	1401h	–	Setup	*1	
	n.□□□X	Tuning-less Selection						When Enabled	
		0	Disable tuning-less function.					After restart	
	1	Enable tuning-less function.							
	n.□□X□	Speed Control Method						When Enabled	
		0	Use for speed control.					After restart	
	1	Use for speed control and use host controller for position control.							
	n.□X□□	Rigidity Level						When Enabled	
		0 to 7	Set the rigidity level.					Immediately	
	n.X□□□	Tuning-less Load Level						When Enabled	
0 to 2		Set the load level for the tuning-less function.					Immediately		
Pn205 (2205h)	2	Multiturn Limit	0 to 65,535	1 rev	65535	After restart	Setup	*1	
Pn207 (2207h)	2	Position Control Function Selections	0000h to 2210h	–	0010h	After restart	Setup	–	
	n.□□□X	Reserved parameter (Do not change.)							
	n.□□X□	Reserved parameter (Do not change.)							
	n.□X□□	Reserved parameter (Do not change.)							
	n.X□□□	/COIN (Positioning Completion Output) Signal Output Timing						Reference	
		0	Output when the absolute value of the position deviation is the same or less than the setting of Pn522 (2522h) (Positioning Completed Width).					*1	
1		Output when the absolute value of the position error is the same or less than the setting of Pn522 (2522h) (Positioning Completed Width) and the reference after the position reference filter is 0.							
2	Output when the absolute value of the position error is the same or less than the setting of Pn522 (2522h) (Positioning Completed Width) and the reference input is 0.								
Pn20A (220Ah)	4	Number of External Encoder Scale Pitches	4 to 1,048,576	1 scale pitch/revolution	32768	After restart	Setup	*1	
Pn20E (220Eh)	4	Electronic Gear Ratio (Numerator)*6	1 to 1,073,741,824	1	16	After restart	Setup	–	
Pn210 (2210h)	4	Electronic Gear Ratio (Denominator)*6	1 to 1,073,741,824	1	1	After restart	Setup	–	
Pn212 (2212h)	4	Number of Encoder Output Pulses	16 to 1,073,741,824	1 P/Rev	2048	After restart	Setup	*1	

Continued on next page.

4.1 List of Parameters

4.1.2 List of Parameters

Continued from previous page.

Parameter No.	Size	Name	Setting Range	Setting Unit	Default Setting	When Enabled	Classification	Reference	
Pn22A (222Ah)	2	Fully-closed Control Selections	0000h to 1003h	–	0000h	After restart	Setup	*1	
		n.□□□X	Reserved parameter (Do not change.)						
		n.□□X□	Reserved parameter (Do not change.)						
		n.□X□□	Reserved parameter (Do not change.)						
		n.X□□□	Fully-closed Control Speed Feedback Selection						
			0	Use motor encoder speed.					
		1	Use external encoder speed.						
Pn230 (2230h)	2	Position Control Expansion Function Selections	0000h to 0001h	–	0000h	After restart	Setup	*1	
		n.□□□X	Backlash Compensation Direction						
			0	Compensate forward references.					
			1	Compensate reverse references.					
		n.□□X□	Reserved parameter (Do not change.)						
		n.□X□□	Reserved parameter (Do not change.)						
	n.X□□□	Reserved parameter (Do not change.)							
Pn231 (2231h)	4	Backlash Compensation	-500,000 to 500,000	0.1 reference units	0	Immediately	Setup	*1	
Pn233 (2233h)	2	Backlash Compensation Time Constant	0 to 65,535	0.01 ms	0	Immediately	Setup	*1	
Pn281 (2281h)	2	Encoder Output Resolution	1 to 4,096	1 edge/pitch	20	After restart	Setup	*1	
Pn304 (2304h)	2	Jogging Speed	0 to 10,000	Rotary: 1 min ⁻¹ Direct Drive: 0.1 min ⁻¹	500	Immediately	Setup	*1	
Pn305 (2305h)	2	Soft Start Acceleration Time	0 to 10,000	1 ms	0	Immediately	Setup	–	
Pn306 (2306h)	2	Soft Start Deceleration Time	0 to 10,000	1 ms	0	Immediately	Setup	–	
Pn308 (2308h)	2	Speed Feedback Filter Time Constant	0 to 65,535	0.01 ms	0	Immediately	Setup	*1	
Pn30A (230Ah)	2	Deceleration Time for Servo OFF and Forced Stops	0 to 10,000	1 ms	0	Immediately	Setup	*1	
Pn30C (230Ch)	2	Speed Feedforward Average Movement Time	0 to 5,100	0.1 ms	0	Immediately	Setup	–	

Continued on next page.

Continued from previous page.

Parameter No.	Size	Name	Setting Range	Setting Unit	Default Setting	When Enabled	Classification	Reference	
Pn310 (2310h)	2	Vibration Detection Selections	0000h to 0002h	–	0000h	Immediately	Setup	*1	
	n.□□□X	Vibration Detection Selection							
		0	Do not detect vibration.						
		1	Output a warning (A.911) if vibration is detected.						
		2	Output an alarm (A.520) if vibration is detected.						
	n.□□X□	Reserved parameter (Do not change.)							
	n.□X□□	Reserved parameter (Do not change.)							
n.X□□□	Reserved parameter (Do not change.)								
Pn311 (2311h)	2	Vibration Detection Sensitivity	50 to 500	1%	100	Immediately	Tuning	*1	
Pn312 (2312h)	2	Vibration Detection Level	0 to 5,000	1 min ⁻¹	50	Immediately	Tuning	*1	
Pn316 (2316h)	2	Maximum Motor Speed	0 to 65,535	1 min ⁻¹	10000	After restart	Setup	*1	
Pn324 (2324h)	2	Moment of Inertia Calculation Starting Level	0 to 20,000	1%	300	Immediately	Setup	*1	
Pn383 (2383h)	2	Jogging Speed	0 to 10,000	1 mm/s	50	Immediately	Setup	*1	
Pn384 (2384h)	2	Vibration Detection Level	0 to 5,000	1 mm/s	10	Immediately	Tuning	*1	
Pn385 (2385h)	2	Maximum Motor Speed	1 to 100	100 mm/s	50	After restart	Setup	*1	
Pn401 (2401h)	2	First Stage First Torque Reference Filter Time Constant	0 to 65,535	0.01 ms	100	Immediately	Tuning	*1	
Pn402 (2402h)	2	Forward Torque Limit	0 to 800	1%*2	800	Immediately	Setup	*1	
Pn403 (2403h)	2	Reverse Torque Limit	0 to 800	1%*2	800	Immediately	Setup	*1	
Pn404 (2404h)	2	Forward External Torque Limit	0 to 800	1%*2	100	Immediately	Setup	*1	
Pn405 (2405h)	2	Reverse External Torque Limit	0 to 800	1%*2	100	Immediately	Setup	*1	
Pn406 (2406h)	2	Emergency Stop Torque	0 to 800	1%*2	800	Immediately	Setup	*1	
Pn407 (2407h)	2	Speed Limit during Torque Control	0 to 10,000	1 min ⁻¹	10000	Immediately	Setup	–	

Continued on next page.

4.1 List of Parameters

4.1.2 List of Parameters

Continued from previous page.

Parameter No.	Size	Name	Setting Range	Setting Unit	Default Setting	When Enabled	Classification	Reference	
Pn408 (2408h)	2	Torque-Related Function Selections	0000h to 1111h	-	0000h	-	Setup	*1	
	n.□□□X	Notch Filter Selection 1						When Enabled	
		0	Disable first stage notch filter.					Immediately	
	1	Enable first stage notch filter.							
	n.□□X□	Speed Limit Selection						When Enabled	
		0	Use the smaller of the maximum motor speed and the setting of Pn407 (2407h) as the speed limit.					After restart	
	1	Use the smaller of the overspeed alarm detection speed and the setting of Pn407 (2407h) as the speed limit.							
	n.□X□□	Notch Filter Selection 2						When Enabled	
		0	Disable second stage notch filter.					Immediately	
	1	Enable second stage notch filter.							
	n.X□□□	Friction Compensation Function Selection						When Enabled	
		0	Disable friction compensation.					Immediately	
1	Enable friction compensation.								
Pn409 (2409h)	2	First Stage Notch Filter Frequency	50 to 5,000	1 Hz	5000	Immediately	Tuning	*1	
Pn40A (240Ah)	2	First Stage Notch Filter Q Value	50 to 1,000	0.01	70	Immediately	Tuning	*1	
Pn40B (240Bh)	2	First Stage Notch Filter Depth	0 to 1,000	0.001	0	Immediately	Tuning	*1	
Pn40C (240Ch)	2	Second Stage Notch Filter Frequency	50 to 5,000	1 Hz	5000	Immediately	Tuning	*1	
Pn40D (240Dh)	2	Second Stage Notch Filter Q Value	50 to 1,000	0.01	70	Immediately	Tuning	*1	
Pn40E (240Eh)	2	Second Stage Notch Filter Depth	0 to 1,000	0.001	0	Immediately	Tuning	*1	
Pn40F (240Fh)	2	Second Stage Second Torque Reference Filter Frequency	100 to 5,000	1 Hz	4000	Immediately	Tuning	*1	
Pn410 (2410h)	2	Second Stage Second Torque Reference Filter Q Value	50 to 100	0.01	50	Immediately	Tuning	*1	
Pn412 (2412h)	2	First Stage Second Torque Reference Filter Time Constant	0 to 65,535	0.01 ms	100	Immediately	Tuning	*1	

Continued on next page.

Continued from previous page.

Parameter No.	Size	Name	Setting Range	Setting Unit	Default Setting	When Enabled	Classification	Reference
Pn416 (2416h)	2	Torque-Related Function Selections 2	0000h to 1111h	–	0000h	Immediately	Setup	*1
	n.□□□X	Notch Filter Selection 3						
		0	Disable third stage notch filter.					
		1	Enable third stage notch filter.					
	n.□□X□	Notch Filter Selection 4						
		0	Disable fourth stage notch filter.					
		1	Enable fourth stage notch filter.					
	n.□X□□	Notch Filter Selection 5						
		0	Disable fifth stage notch filter.					
		1	Enable fifth stage notch filter.					
n.X□□□	Reserved parameter (Do not change.)							
Pn417 (2417h)	2	Third Stage Notch Filter Frequency	50 to 5,000	1 Hz	5000	Immediately	Tuning	*1
Pn418 (2418h)	2	Third Stage Notch Filter Q Value	50 to 1,000	0.01	70	Immediately	Tuning	*1
Pn419 (2419h)	2	Third Stage Notch Filter Depth	0 to 1,000	0.001	0	Immediately	Tuning	*1
Pn41A (241Ah)	2	Fourth Stage Notch Filter Frequency	50 to 5,000	1 Hz	5000	Immediately	Tuning	*1
Pn41B (241Bh)	2	Fourth Stage Notch Filter Q Value	50 to 1,000	0.01	70	Immediately	Tuning	*1
Pn41C (241Ch)	2	Fourth Stage Notch Filter Depth	0 to 1,000	0.001	0	Immediately	Tuning	*1
Pn41D (241Dh)	2	Fifth Stage Notch Filter Frequency	50 to 5,000	1 Hz	5000	Immediately	Tuning	*1
Pn41E (241Eh)	2	Fifth Stage Notch Filter Q Value	50 to 1,000	0.01	70	Immediately	Tuning	*1
Pn41F (241Fh)	2	Fifth Stage Notch Filter Depth	0 to 1,000	0.001	0	Immediately	Tuning	*1
Pn423 (2423h)	2	Speed Ripple Compensation Selections	0000h to 1111h	–	0000h	–	Setup	*1
	n.□□□X	Speed Ripple Compensation Function Selection					When Enabled	
		0	Disable speed ripple compensation.				Immediately	
		1	Enable speed ripple compensation.					
	n.□□X□	Speed Ripple Compensation Information Disagreement Warning Detection Selection					When Enabled	
		0	Detect A.942 alarms.				After restart	
		1	Do not detect A.942 alarms.					
	n.□X□□	Speed Ripple Compensation Enable Condition Selection					When Enabled	
		0	Speed reference				After restart	
		1	Motor speed					
n.X□□□	Reserved parameter (Do not change.)							
Pn424 (2424h)	2	Torque Limit at Main Circuit Voltage Drop	0 to 100	1%*2	50	Immediately	Setup	*1

Continued on next page.

4.1 List of Parameters

4.1.2 List of Parameters

Continued from previous page.

Parameter No.	Size	Name	Setting Range	Setting Unit	Default Setting	When Enabled	Classification	Reference
Pn425 (2425h)	2	Release Time for Torque Limit at Main Circuit Voltage Drop	0 to 1,000	1 ms	100	Immediately	Setup	*1
Pn426 (2426h)	2	Torque Feedforward Average Movement Time	0 to 5,100	0.1 ms	0	Immediately	Setup	–
Pn427 (2427h)	2	Speed Ripple Compensation Enable Speed	0 to 10,000	1 min ⁻¹	0	Immediately	Tuning	*1
Pn456 (2456h)	2	Sweep Torque Reference Amplitude	1 to 800	1%	15	Immediately	Tuning	*1
Pn460 (2460h)	2	Notch Filter Adjustment Selections 1	0000h to 0101h	–	0101h	Immediately	Tuning	*1
	n.□□□X	Notch Filter Adjustment Selection 1						
		0	Do not adjust the first stage notch filter automatically during execution of autotuning without a host reference, autotuning with a host reference, and custom tuning.					
	1	Adjust the first stage notch filter automatically during execution of autotuning without a host reference, autotuning with a host reference, and custom tuning.						
	n.□□X□	Reserved parameter (Do not change.)						
	n.□X□□	Notch Filter Adjustment Selection 2						
		0	Do not adjust the second stage notch filter automatically when the tuning-less function is enabled or during execution of autotuning without a host reference, autotuning with a host reference, and custom tuning.					
1	Adjust the second stage notch filter automatically when the tuning-less function is enabled or during execution of autotuning without a host reference, autotuning with a host reference, and custom tuning.							
n.X□□□	Reserved parameter (Do not change.)							
Pn475 (2475h)	2	Gravity Compensation-Related Selections	0000h to 0001h	–	0000h	After restart	Setup	*1
	n.□□□X	Gravity Compensation Selection						
		0	Disable gravity compensation.					
	1	Enable gravity compensation.						
	n.□□X□	Reserved parameter (Do not change.)						
	n.□X□□	Reserved parameter (Do not change.)						
	n.X□□□	Reserved parameter (Do not change.)						
Pn476 (2476h)	2	Gravity Compensation Torque	-1,000 to 1,000	0.1%	0	Immediately	Tuning	*1
Pn502 (2502h)	2	Rotation Detection Level	1 to 10,000	1 min ⁻¹	20	Immediately	Setup	*1
Pn503 (2503h)	2	Speed Coincidence Detection Signal Output Width	0 to 100	1 min ⁻¹	10	Immediately	Setup	*1
Pn506 (2506h)	2	Brake Reference-Servo OFF Delay Time	0 to 50	10 ms	0	Immediately	Setup	*1
Pn507 (2507h)	2	Brake Reference Output Speed Level	0 to 10,000	1 min ⁻¹	100	Immediately	Setup	*1
Pn508 (2508h)	2	Servo OFF-Brake Command Waiting Time	10 to 100	10 ms	50	Immediately	Setup	*1
Pn509 (2509h)	2	Momentary Power Interruption Hold Time	20 to 50,000	1 ms	20	Immediately	Setup	*1

Continued on next page.

Continued from previous page.

Parameter No.	Size	Name	Setting Range	Setting Unit	Default Setting	When Enabled	Classification	Reference	
Pn50A (250Ah)	2	Input Signal Selections 1	0000h to FFF2h	–	1881h	After restart	Setup	–	
	n.□□□X	Reserved parameter (Do not change.)							
	n.□□X□	Reserved parameter (Do not change.)							
	n.□X□□	Reserved parameter (Do not change.)							
	n.X□□□	P-OT (Forward Drive Prohibit) Signal Allocation							Reference
		0	Enable forward drive when CN1-13 input signal is ON (closed).						*1
		1	Enable forward drive when CN1-7 input signal is ON (closed).						
		2	Enable forward drive when CN1-8 input signal is ON (closed).						
		3	Enable forward drive when CN1-9 input signal is ON (closed).						
		4	Enable forward drive when CN1-10 input signal is ON (closed).						
		5	Enable forward drive when CN1-11 input signal is ON (closed).						
		6	Enable forward drive when CN1-12 input signal is ON (closed).						
		7	Set the signal to always prohibit forward drive.						
		8	Set the signal to always enable forward drive.						
		9	Enable forward drive when CN1-13 input signal is OFF (open).						
		A	Enable forward drive when CN1-7 input signal is OFF (open).						
		B	Enable forward drive when CN1-8 input signal is OFF (open).						
C	Enable forward drive when CN1-9 input signal is OFF (open).								
D	Enable forward drive when CN1-10 input signal is OFF (open).								
E	Enable forward drive when CN1-11 input signal is OFF (open).								
F	Enable forward drive when CN1-12 input signal is OFF (open).								

Continued on next page.

4.1 List of Parameters

4.1.2 List of Parameters

Continued from previous page.

Parameter No.	Size	Name	Setting Range	Setting Unit	Default Setting	When Enabled	Classification	Reference	
Pn50B (250Bh)	2	Input Signal Selections 2	0000h to FFFFh	–	8882h	After restart	Setup	*1	
	n.□□□X	N-OT (Reverse Drive Prohibit) Signal Allocation							
		0	Enable reverse drive when CN1-13 input signal is ON (closed).						
		1	Enable reverse drive when CN1-7 input signal is ON (closed).						
		2	Enable reverse drive when CN1-8 input signal is ON (closed).						
		3	Enable reverse drive when CN1-9 input signal is ON (closed).						
		4	Enable reverse drive when CN1-10 input signal is ON (closed).						
		5	Enable reverse drive when CN1-11 input signal is ON (closed).						
		6	Enable reverse drive when CN1-12 input signal is ON (closed).						
		7	Set the signal to always prohibit reverse drive.						
		8	Set the signal to always enable reverse drive.						
		9	Enable reverse drive when CN1-13 input signal is OFF (open).						
		A	Enable reverse drive when CN1-7 input signal is OFF (open).						
		B	Enable reverse drive when CN1-8 input signal is OFF (open).						
		C	Enable reverse drive when CN1-9 input signal is OFF (open).						
		D	Enable reverse drive when CN1-10 input signal is OFF (open).						
		E	Enable reverse drive when CN1-11 input signal is OFF (open).						
		F	Enable reverse drive when CN1-12 input signal is OFF (open).						
	n.□□□□	Reserved parameter (Do not change.)							
	n.□X□□	/P-CL (Forward External Torque Limit Input) Signal Allocation							
		0	Active when CN1-13 input signal is ON (closed).						
		1	Active when CN1-7 input signal is ON (closed).						
		2	Active when CN1-8 input signal is ON (closed).						
		3	Active when CN1-9 input signal is ON (closed).						
		4	Active when CN1-10 input signal is ON (closed).						
		5	Active when CN1-11 input signal is ON (closed).						
		6	Active when CN1-12 input signal is ON (closed).						
		7	The signal is always active.						
		8	The signal is always inactive.						
		9	Active when CN1-13 input signal is OFF (open).						
		A	Active when CN1-7 input signal is OFF (open).						
		B	Active when CN1-8 input signal is OFF (open).						
		C	Active when CN1-9 input signal is OFF (open).						
D		Active when CN1-10 input signal is OFF (open).							
E		Active when CN1-11 input signal is OFF (open).							
F		Active when CN1-12 input signal is OFF (open).							
n.X□□□	/N-CL (Reverse External Torque Limit Input) Signal Allocation								
	0 to F	The allocations are the same as the /P-CL (Forward External Torque Limit Input) signal allocations.							

Continued on next page.

Continued from previous page.

Parameter No.	Size	Name	Setting Range	Setting Unit	Default Setting	When Enabled	Classification	Reference	
Pn50E (250Eh)	2	Output Signal Selections 1	0000h to 6666h	–	0000h	After restart	Setup	*1	
	n.□□□X	/COIN (Positioning Completion Output) Signal Allocation							
		0	Disabled (the above signal output is not used).						
		1	Output the signal from the CN1-1 or CN1-2 output terminal.						
		2	Output the signal from the CN1-23 or CN1-24 output terminal.						
		3	Output the signal from the CN1-25 or CN1-26 output terminal.						
	4 to 6	Reserved setting (Do not use.)							
	n.□□X□	/V-CMP (Speed Coincidence Detection Output) Signal Allocation							
		0 to 6	The allocations are the same as the /COIN (Positioning Completion) signal allocations.						
	n.□X□□	/TGON (Rotation Detection Output) Signal Allocation							
		0 to 6	The allocations are the same as the /COIN (Positioning Completion) signal allocations.						
	n.X□□□	/S-RDY (Servo Ready) Signal Allocation							
		0 to 6	The allocations are the same as the /COIN (Positioning Completion) signal allocations.						
	Pn50F (250Fh)	2	Output Signal Selections 2	0000h to 6666h	–	0100h	After restart	Setup	*1
		n.□□□X	/CLT (Torque Limit Detection Output) Signal Allocation						
0			Disabled (the above signal output is not used).						
1			Output the signal from the CN1-1 or CN1-2 output terminal.						
2			Output the signal from the CN1-23 or CN1-24 output terminal.						
3			Output the signal from the CN1-25 or CN1-26 output terminal.						
4 to 6		Reserved setting (Do not use.)							
n.□□X□		/VLT (Speed Limit Detection) Signal Allocation							
		0 to 6	The allocations are the same as the /CLT (Torque Limit Detection Output) signal allocations.						
n.□X□□		/BK (Brake Output) Signal Allocation							
		0 to 6	The allocations are the same as the /CLT (Torque Limit Detection Output) signal allocations.						
n.X□□□		/WARN (Warning Output) Signal Allocation							
		0 to 6	The allocations are the same as the /CLT (Torque Limit Detection Output) signal allocations.						

Continued on next page.

4.1 List of Parameters

4.1.2 List of Parameters

Continued from previous page.

Parameter No.	Size	Name	Setting Range	Setting Unit	Default Setting	When Enabled	Classification	Reference	
Pn510 (2510h)	2	Output Signal Selections 3	0000h to 0666h	-	0000h	After restart	Setup	-	
			/NEAR (Near Output) Signal Allocation						Reference
	n.□□□X		0	Disabled (the above signal output is not used).					*1
			1	Output the signal from the CN1-1 or CN1-2 output terminal.					
			2	Output the signal from the CN1-23 or CN1-24 output terminal.					
			3	Output the signal from the CN1-25 or CN1-26 output terminal.					
			4 to 6	Reserved setting (Do not use.)					
	n.□□X□		Reserved parameter (Do not change.)						
	n.□X□□		Reserved parameter (Do not change.)						
	n.X□□□		Reserved parameter (Do not change.)						
Pn511 (2511h)	2	Input Signal Selections 5	0000h to FFFFh	-	6543h	After restart	Setup	*1	
	n.□□□X		Reserved parameter (Do not change.)						
			/Probe1 (Probe 1 Latch Input) Signal Allocation						
	n.□□X□		4	Active when CN1-10 input signal is ON (closed).					
			5	Active when CN1-11 input signal is ON (closed).					
			6	Active when CN1-12 input signal is ON (closed).					
			7	The signal is always inactive.					
			8	The signal is always inactive.					
			D	Active when CN1-10 input signal is OFF (open).					
			E	Active when CN1-11 input signal is OFF (open).					
F			Active when CN1-12 input signal is OFF (open).						
n.X□□□		/Probe2 (Probe 2 Latch Input) Signal Allocation							
		0 to F	The allocations are the same as the /Probe1 (Probe 1 Latch Input) signal allocations.						
n.X□□□		/Home (Home Switch Input) Signal Allocation							
		0 to F	The allocations are the same as the /Probe1 (Probe 1 Latch Input) signal allocations.						
Pn512 (2512h)	2	Output Signal Inverse Settings	0000h to 1111h	-	0000h	After restart	Setup	*1	
	n.□□□X		Output Signal Inversion for CN1-1 and CN1-2 Terminals						
			0	The signal is not inverted.					
			1	The signal is inverted.					
	n.□□X□		Output Signal Inversion for CN1-23 and CN1-24 Terminals						
			0	The signal is not inverted.					
			1	The signal is inverted.					
	n.□X□□		Output Signal Inversion for CN1-25 and CN1-26 Terminals						
			0	The signal is not inverted.					
			1	The signal is inverted.					
n.X□□□		Reserved parameter (Do not change.)							

Continued on next page.

Continued from previous page.

Parameter No.	Size	Name	Setting Range	Setting Unit	Default Setting	When Enabled	Classification	Reference	
Pn514 (2514h)	2	Output Signal Selections 4	0000h to 0666h	–	0000h	After restart	Setup	–	
	n.□□□X		Reserved parameter (Do not change.)						
	n.□□X□		Reserved parameter (Do not change.)						
	n.□X□□	/PM (Preventative Maintenance Output) Signal Allocation							Reference
		0	Disabled (the above signal output is not used).						*1
		1	Output the signal from the CN1-1 or CN1-2 output terminal.						
		2	Output the signal from the CN1-23 or CN1-24 output terminal.						
		3	Output the signal from the CN1-25 or CN1-26 output terminal.						
	4 to 6	Reserved setting (Do not use.)							
	n.X□□□		Reserved parameter (Do not change.)						
Pn516 (2516h)	2	Input Signal Selections 7	0000h to FFFFh	–	8888h	After restart	Setup	–	
	n.□□□X	FSTP (Forced Stop Input) Signal Allocation							Reference
		0	Enable drive when CN1-13 input signal is ON (closed).						*1
		1	Enable drive when CN1-7 input signal is ON (closed).						
		2	Enable drive when CN1-8 input signal is ON (closed).						
		3	Enable drive when CN1-9 input signal is ON (closed).						
		4	Enable drive when CN1-10 input signal is ON (closed).						
		5	Enable drive when CN1-11 input signal is ON (closed).						
		6	Enable drive when CN1-12 input signal is ON (closed).						
		7	Set the signal to always prohibit drive (always force the motor to stop).						
		8	Set the signal to always enable drive (always disable forcing the motor to stop).						
		9	Enable drive when CN1-13 input signal is OFF (open).						
		A	Enable drive when CN1-7 input signal is OFF (open).						
		B	Enable drive when CN1-8 input signal is OFF (open).						
		C	Enable drive when CN1-9 input signal is OFF (open).						
		D	Enable drive when CN1-10 input signal is OFF (open).						
	E	Enable drive when CN1-11 input signal is OFF (open).							
	F	Enable drive when CN1-12 input signal is OFF (open).							
	n.□□X□		Reserved parameter (Do not change.)						
	n.□X□□		Reserved parameter (Do not change.)						
n.X□□□		Reserved parameter (Do not change.)							
Pn518*4 (2518h)	–	Safety Module-Related Parameters	–	–	–	–	–	–	
Pn51B (251Bh)	4	Motor-Load Position Deviation Overflow Detection Level	0 to 1,073,741,824	1 reference unit	1000	Immediately	Setup	*1	
Pn51E (251Eh)	2	Position Deviation Overflow Warning Level	10 to 100	1%	100	Immediately	Setup	*1	
Pn520 (2520h)	4	Position Deviation Overflow Alarm Level	1 to 1,073,741,823	1 reference unit	5242880	Immediately	Setup	*1	
Pn522 (2522h)	4	Positioning Completed Width	0 to 1,073,741,824	1 reference unit	7	Immediately	Setup	*1	
Pn524 (2524h)	4	Near Signal Width	1 to 1,073,741,824	1 reference unit	1073741824	Immediately	Setup	*1	

Continued on next page.

4.1 List of Parameters

4.1.2 List of Parameters

Continued from previous page.

Parameter No.	Size	Name	Setting Range	Setting Unit	Default Setting	When Enabled	Classification	Reference	
Pn526 (2526h)	4	Position Deviation Overflow Alarm Level at Servo ON	1 to 1,073,741,823	1 reference unit	5242880	Immediately	Setup	*1	
Pn528 (2528h)	2	Position Deviation Overflow Warning Level at Servo ON	10 to 100	1%	100	Immediately	Setup	*1	
Pn529 (2529h)	2	Speed Limit Level at Servo ON	0 to 10,000	1 min ⁻¹	10000	Immediately	Setup	*1	
Pn52A (252Ah)	2	Multiplier per Fully-closed Rotation	0 to 100	1%	20	Immediately	Tuning	*1	
Pn52B (252Bh)	2	Overload Warning Level	1 to 100	1%	20	Immediately	Setup	*1	
Pn52C (252Ch)	2	Base Current Derating at Motor Overload Detection	10 to 100	1%	100	After restart	Setup	*1	
Pn530 (2530h)	2	Program Jogging-Related Selections	0000h to 0005h	-	0000h	Immediately	Setup	*1	
	n.□□□X	Program Jogging Operation Pattern							
		0	(Waiting time in Pn535 → Forward by travel distance in Pn531) × Number of movements in Pn536						
		1	(Waiting time in Pn535 → Reverse by travel distance in Pn531) × Number of movements in Pn536						
		2	(Waiting time in Pn535 → Forward by travel distance in Pn531) × Number of movements in Pn536 (Waiting time in Pn535 → Reverse by travel distance in Pn531) × Number of movements in Pn536						
		3	(Waiting time in Pn535 → Reverse by travel distance in Pn531) × Number of movements in Pn536 (Waiting time in Pn535 → Forward by travel distance in Pn531) × Number of movements in Pn536						
		4	(Waiting time in Pn535 → Forward by travel distance in Pn531 → Waiting time in Pn535 → Reverse by travel distance in Pn531) × Number of movements in Pn536						
	5	(Waiting time in Pn535 → Reverse by travel distance in Pn531 → Waiting time in Pn535 → Forward by travel distance in Pn531) × Number of movements in Pn536							
	n.□□X□	Reserved parameter (Do not change.)							
	n.□X□□	Reserved parameter (Do not change.)							
n.X□□□	Reserved parameter (Do not change.)								
Pn531 (2531h)	4	Program Jogging Travel Distance	1 to 1,073,741,824	1 reference unit	32768	Immediately	Setup	*1	
Pn533 (2533h)	2	Program Jogging Movement Speed	1 to 10,000	Rotary: 1 min ⁻¹ Direct Drive: 0.1 min ⁻¹	500	Immediately	Setup	*1	
Pn534 (2534h)	2	Program Jogging Acceleration/Deceleration Time	2 to 10,000	1 ms	100	Immediately	Setup	*1	
Pn535 (2535h)	2	Program Jogging Waiting Time	0 to 10,000	1 ms	100	Immediately	Setup	*1	
Pn536 (2536h)	2	Program Jogging Number of Movements	0 to 1,000	Times	1	Immediately	Setup	*1	
Pn550 (2550h)	2	Analog Monitor 1 Offset Voltage	-10,000 to 10,000	0.1 V	0	Immediately	Setup	*1	
Pn551 (2551h)	2	Analog Monitor 2 Offset Voltage	-10,000 to 10,000	0.1 V	0	Immediately	Setup	*1	
Pn552 (2552h)	2	Analog Monitor 1 Magnification	-10,000 to 10,000	× 0.01	100	Immediately	Setup	*1	
Pn553 (2553h)	2	Analog Monitor 2 Magnification	-10,000 to 10,000	× 0.01	100	Immediately	Setup	*1	

Continued on next page.

Continued from previous page.

Parameter No.	Size	Name	Setting Range	Setting Unit	Default Setting	When Enabled	Classification	Reference		
Pn55A (255Ah)	2	Power Consumption Monitor Unit Time	1 to 1,440	1 min	1	Immediately	Setup	–		
Pn560 (2560h)	2	Residual Vibration Detection Width	1 to 3,000	0.1%	400	Immediately	Setup	*1		
Pn561 (2561h)	2	Overshoot Detection Level	0 to 100	1%	100	Immediately	Setup	*1		
Pn600 (2600h)	2	Regenerative Resistor Capacity*3	Depends on model.*4	10 W	0	Immediately	Setup	*1		
Pn601 (2601h)	2	Dynamic Brake Resistor Allowable Energy Consumption	0 to 65,535	10 J	0	After restart	Setup	*7		
Pn603 (2603h)	2	Regenerative Resistance	0 to 65,535	10 mΩ	0	Immediately	Setup	*1		
Pn604 (2604h)	2	Dynamic Brake Resistance	0 to 65,535	10 mΩ	0	After restart	Setup	*7		
Pn61A (261Ah)	2	Overheat Protection Selections	0000h to 0003h	–	0000h	After restart	Setup	*1		
		Overheat Protection Selections								
		n.□□□X	0	Disable overheat protection.						
			1	Reserved setting (Do not use.)						
			2	Monitor a negative voltage input from a sensor attached to the machine and use overheat protection.						
			3	Monitor a positive voltage input from a sensor attached to the machine and use overheat protection.						
n.□□X□	Reserved parameter (Do not change.)									
n.□X□□	Reserved parameter (Do not change.)									
n.X□□□	Reserved parameter (Do not change.)									
Pn61B*8 (261Bh)	2	Overheat Alarm Level	0 to 500	0.01 V	250	Immediately	Setup	*1		
Pn61C*8 (261Ch)	2	Overheat Warning Level	0 to 100	1%	100	Immediately	Setup	*1		
Pn61D*8 (261Dh)	2	Overheat Alarm Filter Time	0 to 65,535	1 s	0	Immediately	Setup	*1		
Pn621 (2621h) to Pn628 (2628h)*4	–	Safety Module-Related Parameters	–	–	–	–	–	–		

*1. Refer to the following manual for details.
 Σ-7-Series Σ-7S SERVOPACK with EtherCAT (CoE) Communications References Product Manual (Manual No.: SIEP S800001 55)

*2. Set a percentage of the motor rated torque.

*3. Normally set this parameter to 0. If you use an External Regenerative Resistor, set the capacity (W) of the External Regenerative Resistor.

*4. The upper limit is the maximum output capacity (W) of the SERVOPACK.

*5. These parameters are for SERVOPACKs with a Safety Module. Refer to the following manual for details.
 Σ-V-Series/Σ-V-Series for Large-Capacity Models/Σ-7-Series User's Manual Safety Module (Manual No.: SIEP C720829 06)

*6. With EtherCAT (CoE), this is automatically set when the power supply is turned ON. For setting the electronic gear ratio, use objects 2701h to 2704h. Refer to the following manual for details.
 Σ-7-Series Σ-7S SERVOPACK with EtherCAT (CoE) Communications References Product Manual (Manual No.: SIEP S800001 55)

*7. These parameters are for SERVOPACKs that support the dynamic brake hardware option specifications. Refer to the following manual for details.
 Σ-7-Series AC Servo Drive Σ-7S/Σ-7W SERVOPACK with Dynamic Brake Hardware Option Specifications Product Manual (Manual No.: SIEP S800001 73)

*8. Enabled only when Pn61A is set to n.□□□2 or n.□□□3.

4.2 Object List

Index	Sub-index	Name	Data Type	Access	PDO Mapping	Saving to EEPROM ^{*1}	Default Value	Lower Limit	Upper Limit	Unit	Parameter No. ^{*2}
1000h	0	Device type	UDINT	RO	No	No	0x00020192	-	-	-	-
1001h	0	Error register	USINT	RO	No	No	-	-	-	-	-
1008h	0	Manufacturer device name	STRING	RO	No	No	-	-	-	-	-
100Ah	0	Manufacturer software version	STRING	RO	No	No	-	-	-	-	-
Store parameters											
1010h	0	Largest subindex supported	USINT	RO	No	No	4	-	-	-	-
	1	Save all parameters	UDINT	RW	No	No	0x00000001	0x00000000	0xFFFFFFFF	-	PnC00 ^{*3*4}
	2	Save communication parameters	UDINT	RW	No	No	0x00000001	0x00000000	0xFFFFFFFF	-	PnC02 ^{*3*4}
	3	Save application parameters	UDINT	RW	No	No	0x00000001	0x00000000	0xFFFFFFFF	-	PnC04 ^{*3*4}
	4	Save manufacturer defined parameters	UDINT	RW	No	No	0x00000001	0x00000000	0xFFFFFFFF	-	PnC06 ^{*3*4}
Restore default parameters											
1011h	0	Largest subindex supported	USINT	RO	No	No	4	-	-	-	-
	1	Restore all default parameters	UDINT	RW	No	No	0x00000001	0x00000000	0xFFFFFFFF	-	PnC08 ^{*3*4}
	2	Restore communication default parameters	UDINT	RW	No	No	0x00000001	0x00000000	0xFFFFFFFF	-	PnC0A ^{*3*4}
	3	Restore application default parameters	UDINT	RW	No	No	0x00000001	0x00000000	0xFFFFFFFF	-	PnC0C ^{*3*4}
	4	Restore manufacturer defined default parameters	UDINT	RW	No	No	0x00000001	0x00000000	0xFFFFFFFF	-	PnC0E ^{*3*4}
Identity object											
1018h	0	Number of entries	USINT	RO	No	No	4	-	-	-	-
	1	Vendor ID	UDINT	RO	No	No	0x539	-	-	-	-
	2	Product code	UDINT	RO	No	No	0x02200301 ^{*5}	-	-	-	-
	3	Revision number	UDINT	RO	No	No	-	-	-	-	-
	4	Serial number	UDINT	RO	No	No	0	-	-	-	-
Sync error settings											
10F1h	0	Number of entries	USINT	RO	No	No	2	-	-	-	-
	1	Reserved	UDINT	RO	No	No	0	-	-	-	-
	2	Sync error count limit	UDINT	RW	No	No	9	0	15	-	PnCCC
1st receive PDO mapping											
1600h	0	Number of objects in this PDO	USINT	RW	No	Yes	8	0	8	-	PnCA0
	1	Mapping entry 1	UDINT	RW	No	Yes	0x60400010	0	0xFFFFFFFF	-	PnC20
	2	Mapping entry 2	UDINT	RW	No	Yes	0x607A0020	0	0xFFFFFFFF	-	PnC22
	3	Mapping entry 3	UDINT	RW	No	Yes	0x60FF0020	0	0xFFFFFFFF	-	PnC24
	4	Mapping entry 4	UDINT	RW	No	Yes	0x60710010	0	0xFFFFFFFF	-	PnC26
	5	Mapping entry 5	UDINT	RW	No	Yes	0x60720010	0	0xFFFFFFFF	-	PnC28
	6	Mapping entry 6	UDINT	RW	No	Yes	0x60600008	0	0xFFFFFFFF	-	PnC2A
	7	Mapping entry 7	UDINT	RW	No	Yes	0x00000008	0	0xFFFFFFFF	-	PnC2C
	8	Mapping entry 8	UDINT	RW	No	Yes	0x60B80010	0	0xFFFFFFFF	-	PnC2E

Continued on next page.

Continued from previous page.

Index	Sub-index	Name	Data Type	Access	PDO Mapping	Saving to EEPROM*1	Default Value	Lower Limit	Upper Limit	Unit	Parameter No.*2
1601h	2nd receive PDO mapping										
	0	Number of objects in this PDO	USINT	RW	No	Yes	2	0	8	–	PnCA1
	1	Mapping entry 1	UDINT	RW	No	Yes	0x60400010	0	0xFFFFFFFF	–	PnC30
	2	Mapping entry 2	UDINT	RW	No	Yes	0x607A0020	0	0xFFFFFFFF	–	PnC32
	3	Mapping entry 3	UDINT	RW	No	Yes	0	0	0xFFFFFFFF	–	PnC34
	4	Mapping entry 4	UDINT	RW	No	Yes	0	0	0xFFFFFFFF	–	PnC36
	5	Mapping entry 5	UDINT	RW	No	Yes	0	0	0xFFFFFFFF	–	PnC38
	6	Mapping entry 6	UDINT	RW	No	Yes	0	0	0xFFFFFFFF	–	PnC3A
	7	Mapping entry 7	UDINT	RW	No	Yes	0	0	0xFFFFFFFF	–	PnC3C
8	Mapping entry 8	UDINT	RW	No	Yes	0	0	0xFFFFFFFF	–	PnC3E	
1602h	3rd receive PDO mapping										
	0	Number of objects in this PDO	USINT	RW	No	Yes	2	0	8	–	PnCA2
	1	Mapping entry 1	UDINT	RW	No	Yes	0x60400010	0	0xFFFFFFFF	–	PnC40
	2	Mapping entry 2	UDINT	RW	No	Yes	0x60FF0020	0	0xFFFFFFFF	–	PnC42
	3	Mapping entry 3	UDINT	RW	No	Yes	0	0	0xFFFFFFFF	–	PnC44
	4	Mapping entry 4	UDINT	RW	No	Yes	0	0	0xFFFFFFFF	–	PnC46
	5	Mapping entry 5	UDINT	RW	No	Yes	0	0	0xFFFFFFFF	–	PnC48
	6	Mapping entry 6	UDINT	RW	No	Yes	0	0	0xFFFFFFFF	–	PnC4A
	7	Mapping entry 7	UDINT	RW	No	Yes	0	0	0xFFFFFFFF	–	PnC4C
8	Mapping entry 8	UDINT	RW	No	Yes	0	0	0xFFFFFFFF	–	PnC4E	
1603h	4th receive PDO mapping										
	0	Number of objects in this PDO	USINT	RW	No	Yes	2	0	8	–	PnCA3
	1	Mapping entry 1	UDINT	RW	No	Yes	0x60400010	0	0xFFFFFFFF	–	PnC50
	2	Mapping entry 2	UDINT	RW	No	Yes	0x60710010	0	0xFFFFFFFF	–	PnC52
	3	Mapping entry 3	UDINT	RW	No	Yes	0	0	0xFFFFFFFF	–	PnC54
	4	Mapping entry 4	UDINT	RW	No	Yes	0	0	0xFFFFFFFF	–	PnC56
	5	Mapping entry 5	UDINT	RW	No	Yes	0	0	0xFFFFFFFF	–	PnC58
	6	Mapping entry 6	UDINT	RW	No	Yes	0	0	0xFFFFFFFF	–	PnC5A
	7	Mapping entry 7	UDINT	RW	No	Yes	0	0	0xFFFFFFFF	–	PnC5C
8	Mapping entry 8	UDINT	RW	No	Yes	0	0	0xFFFFFFFF	–	PnC5E	
1A00h	1st transmit PDO mapping										
	0	Number of objects in this PDO	USINT	RW	No	Yes	8	0	8	–	PnCA4
	1	Mapping entry 1	UDINT	RW	No	Yes	0x60410010	0	0xFFFFFFFF	–	PnC60
	2	Mapping entry 2	UDINT	RW	No	Yes	0x60640020	0	0xFFFFFFFF	–	PnC62
	3	Mapping entry 3	UDINT	RW	No	Yes	0x60770010	0	0xFFFFFFFF	–	PnC64
	4	Mapping entry 4	UDINT	RW	No	Yes	0x60F40020	0	0xFFFFFFFF	–	PnC66
	5	Mapping entry 5	UDINT	RW	No	Yes	0x60610008	0	0xFFFFFFFF	–	PnC68
	6	Mapping entry 6	UDINT	RW	No	Yes	0x00000008	0	0xFFFFFFFF	–	PnC6A
	7	Mapping entry 7	UDINT	RW	No	Yes	0x60B90010	0	0xFFFFFFFF	–	PnC6C
8	Mapping entry 8	UDINT	RW	No	Yes	0x60BA0020	0	0xFFFFFFFF	–	PnC6E	

Continued on next page.

Continued from previous page.

Index	Sub-index	Name	Data Type	Access	PDO Mapping	Saving to EEPROM ^{*1}	Default Value	Lower Limit	Upper Limit	Unit	Parameter No. ^{*2}
1A01h	2nd transmit PDO mapping										
	0	Number of objects in this PDO	USINT	RW	No	Yes	2	0	8	-	PnCA5
	1	Mapping entry 1	UDINT	RW	No	Yes	0x60410010	0	0xFFFFFFFF	-	PnC70
	2	Mapping entry 2	UDINT	RW	No	Yes	0x60640020	0	0xFFFFFFFF	-	PnC72
	3	Mapping entry 3	UDINT	RW	No	Yes	0	0	0xFFFFFFFF	-	PnC74
	4	Mapping entry 4	UDINT	RW	No	Yes	0	0	0xFFFFFFFF	-	PnC76
	5	Mapping entry 5	UDINT	RW	No	Yes	0	0	0xFFFFFFFF	-	PnC78
	6	Mapping entry 6	UDINT	RW	No	Yes	0	0	0xFFFFFFFF	-	PnC7A
	7	Mapping entry 7	UDINT	RW	No	Yes	0	0	0xFFFFFFFF	-	PnC7C
8	Mapping entry 8	UDINT	RW	No	Yes	0	0	0xFFFFFFFF	-	PnC7E	
1A02h	3rd transmit PDO mapping										
	0	Number of objects in this PDO	USINT	RW	No	Yes	2	0	8	-	PnCA6
	1	Mapping entry 1	UDINT	RW	No	Yes	0x60410010	0	0xFFFFFFFF	-	PnC80
	2	Mapping entry 2	UDINT	RW	No	Yes	0x60640020	0	0xFFFFFFFF	-	PnC82
	3	Mapping entry 3	UDINT	RW	No	Yes	0	0	0xFFFFFFFF	-	PnC84
	4	Mapping entry 4	UDINT	RW	No	Yes	0	0	0xFFFFFFFF	-	PnC86
	5	Mapping entry 5	UDINT	RW	No	Yes	0	0	0xFFFFFFFF	-	PnC88
	6	Mapping entry 6	UDINT	RW	No	Yes	0	0	0xFFFFFFFF	-	PnC8A
	7	Mapping entry 7	UDINT	RW	No	Yes	0	0	0xFFFFFFFF	-	PnC8C
8	Mapping entry 8	UDINT	RW	No	Yes	0	0	0xFFFFFFFF	-	PnC8E	
1A03h	4th transmit PDO mapping										
	0	Number of objects in this PDO	USINT	RW	No	Yes	3	0	8	-	PnCA7
	1	Mapping entry 1	UDINT	RW	No	Yes	0x60410010	0	0xFFFFFFFF	-	PnC90
	2	Mapping entry 2	UDINT	RW	No	Yes	0x60640020	0	0xFFFFFFFF	-	PnC92
	3	Mapping entry 3	UDINT	RW	No	Yes	0x60770010	0	0xFFFFFFFF	-	PnC94
	4	Mapping entry 4	UDINT	RW	No	Yes	0	0	0xFFFFFFFF	-	PnC96
	5	Mapping entry 5	UDINT	RW	No	Yes	0	0	0xFFFFFFFF	-	PnC98
	6	Mapping entry 6	UDINT	RW	No	Yes	0	0	0xFFFFFFFF	-	PnC9A
	7	Mapping entry 7	UDINT	RW	No	Yes	0	0	0xFFFFFFFF	-	PnC9C
8	Mapping entry 8	UDINT	RW	No	Yes	0	0	0xFFFFFFFF	-	PnC9E	
1C00h	Sync Manager communication type										
	0	Number of used Sync Manager channels	USINT	RO	No	No	4	-	-	-	-
	1	Communication type sync manager 0	USINT	RO	No	No	1	-	-	-	PnCB0 ^{*4}
	2	Communication type sync manager 1	USINT	RO	No	No	2	-	-	-	PnCB1 ^{*4}
	3	Communication type sync manager 2	USINT	RO	No	No	3	-	-	-	PnCB2 ^{*4}
4	Communication type sync manager 3	USINT	RO	No	No	4	-	-	-	PnCB3 ^{*4}	
1C10h	0	Sync Manager PDO assignment 0	USINT	RO	No	No	0	-	-	-	-
1C11h	0	Sync Manager PDO assignment 1	USINT	RO	No	No	0	-	-	-	-
1C12h	Sync Manager PDO assignment 2										
	0	Number of assigned PDOs	USINT	RW	No	Yes	1	0	2	-	PnCB5
	1	Index of assigned RxPDO 1	UINT	RW	No	Yes	0x1601	0x1600	0x1603	-	PnCB6
2	Index of assigned RxPDO 2	UINT	RW	No	Yes	0x1600	0x1600	0x1603	-	PnCB7	

Continued on next page.

Continued from previous page.

Index	Sub-index	Name	Data Type	Access	PDO Mapping	Saving to EEPROM* ¹	Default Value	Lower Limit	Upper Limit	Unit	Parameter No.* ²
1C13h	Sync Manager PDO assignment 3										
	0	Number of assigned PDOs	USINT	RW	No	Yes	1	0	2	–	PnCBB
	1	Index of assigned TxPDO 1	UINT	RW	No	Yes	0x1A01	0x1A00	0x1A03	–	PnCBC
	2	Index of assigned TxPDO 2	UINT	RW	No	Yes	0x1A00	0x1A00	0x1A03	–	PnCBD
1C32h	Sync Manager 2 (process data output) synchronization										
	0	Number of synchronization parameters	USINT	RO	No	No	10	–	–	–	–
	1	Synchronization type	UINT	RO	No	No	–	–	–	–	PnCC0* ⁴
	2	Cycle time	UDINT	RO	No	No	–	–	–	–	PnCC2* ⁴
	3	Shift time	UDINT	RO	No	No	125000	–	–	–	PnCC4* ⁴
	4	Synchronization types supported	UINT	RO	No	No	0x0005	–	–	–	–
	5	Minimum cycle time	UDINT	RO	No	No	62500	–	–	–	–
	6	Calc and copy time	UDINT	RO	No	No	62500	–	–	–	–
	7	Reserved	UDINT	RO	No	No	–	–	–	–	–
	8	Reserved	UINT	RO	No	No	–	–	–	–	–
	9	Delay time	UDINT	RO	No	No	0	–	–	–	–
	10	Sync0 cycle time	UDINT	RO	No	No	–	–	–	–	PnCC6* ⁴
	11	SM2 event miss count	UDINT	RO	No	No	–	–	–	–	PnCC8* ⁴
12	Reserved	UDINT	RO	No	No	–	–	–	–	–	
1C33h	Sync Manager 3 (process data input) synchronization										
	0	Number of synchronization parameters	USINT	RO	No	No	10	–	–	–	–
	1	Synchronization type	UINT	RO	No	No	–	–	–	–	–
	2	Cycle time	UDINT	RO	No	No	–	–	–	–	–
	3	Shift time	UDINT	RW	No	Yes	0	0	Sync0 event cycle - 12,500	–	PnCCA
	4	Synchronization types supported	UINT	RO	No	No	0x0025	–	–	–	–
	5	Minimum cycle time	UDINT	RO	No	No	62500	–	–	–	–
	6	Calc and copy time	UDINT	RO	No	No	62500	–	–	–	–
	7	Reserved	UDINT	RO	No	No	–	–	–	–	–
	8	Reserved	UINT	RO	No	No	–	–	–	–	–
	9	Delay time	UDINT	RO	No	No	0	–	–	–	–
	10	Sync0 cycle time	UDINT	RO	No	No	–	–	–	–	–
	11	SM2 event miss count	UDINT	RO	No	No	–	–	–	–	–
12	Reserved	UDINT	RO	No	No	–	–	–	–	–	
2000h to 26FFh	0	SERVOPACK parameters (Pn000 (2000h) to Pn6FF (26FFh))	–	–	–	–	–	–	–	–	Pn000* ⁶ – Pn6FF* ⁶
2700h	0	User parameter Configuration	UDINT	RW	No	No	0	0	0xFFFFFFFF	–	PnB00
2701h	Position user unit										
	0	Number of entries	USINT	RO	No	No	2	–	–	–	–
	1	Numerator	UDINT	RW	No	Yes	1	1	1073741823	–	PnB02
	2	Denominator	UDINT	RW	No	Yes	1	1	1073741823	–	PnB04
2702h	Velocity user unit										
	0	Number of entries	USINT	RO	No	No	2	–	–	–	–
	1	Numerator	UDINT	RW	No	Yes	1	1	1073741823	–	PnB06
	2	Denominator	UDINT	RW	No	Yes	1	1	1073741823	–	PnB08

Continued on next page.

Continued from previous page.

Index	Sub-index	Name	Data Type	Access	PDO Mapping	Saving to EEPROM ^{*1}	Default Value	Lower Limit	Upper Limit	Unit	Parameter No. ^{*2}
2703h	Acceleration user unit										
	0	Number of entries	USINT	RO	No	No	2	-	-	-	-
	1	Numerator	UDINT	RW	No	Yes	1	1	1073741823	-	PnB0A
	2	Denominator	UDINT	RW	No	Yes	1	1	1073741823	-	PnB0C
2704h	Torque user unit										
	0	Number of entries	USINT	RO	No	No	2	-	-	-	-
	1	Numerator	UDINT	RW	No	Yes	1	1	1073741823	-	PnB94
	2	Denominator	UDINT	RW	No	Yes	10	1	1073741823	-	PnB96
2705h	0	Encoder Selection	USINT	RW	No	Yes	0x0000	0x0000	0x0001	-	PnB9C
2710h	SERVOPACK adjusting command										
	0	Number of entries	USINT	RO	No	No	3	-	-	-	-
	1	Command	STRING	RW	No	No	0	0	0xFF	-	-
	2	Status	USINT	RO	No	No	-	-	-	-	-
	3	Reply	STRING	RO	No	No	-	-	-	-	-
2720h	0	Safety Module monitor	UDINT	RO	Yes	No	-	-	-	-	-
2730h	Interpolation data configuration for 1st profile										
	0	Number of entries	USINT	RO	No	No	9	-	-	-	-
	1	Maximum buffer size	UDINT	RO	No	No	254	-	-	-	-
	2	Actual buffer size	UDINT	RW	No	No	254	-	-	-	-
	3	Buffer organization	USINT	RW	No	No	0	0	1	-	PnCCEC
	4	Buffer position	UINT	RW	Yes	No	1	1	255	-	PnCCEd
	5	Size of data record	USINT	WO	No	No	1	1	1	-	-
	6	Buffer clear	USINT	WO	No	No	0	0	1	-	-
	7	Position data definition	USINT	RW	Yes	No	1	0	1	-	PnCCEE
	8	Position data polarity	USINT	RW	Yes	No	0	0	1	-	PnCCEF
	9	Behavior after reaching buffer position	USINT	RW	Yes	No	0	0	1	-	PnCFF0
2731h	Interpolation data configuration for 2nd profile										
	0	Number of entries	USINT	RO	No	No	9	-	-	-	-
	1	Maximum buffer size	UDINT	RO	No	No	254	-	-	-	-
	2	Actual buffer size	UDINT	RW	No	No	254	-	-	-	-
	3	Buffer organization	USINT	RW	No	No	0	0	1	-	PnCF1
	4	Buffer position	UINT	RW	Yes	No	1	1	255	-	PnCF2
	5	Size of data record	USINT	WO	No	No	1	1	1	-	-
	6	Buffer clear	USINT	WO	No	No	0	0	1	-	-
	7	Position data definition	USINT	RW	Yes	No	1	0	1	-	PnCF3
	8	Position data polarity	USINT	RW	Yes	No	0	0	1	-	PnCF4
	9	Behavior after reaching buffer position	USINT	RW	Yes	No	0	0	1	-	PnCF5
2732h	0	Interpolation profile select	USINT	RW	Yes	No	0	0	1	-	PnCF6
2741h	Interpolation data read/write pointer position monitor										
	0	Number of entries	UINT	RO	No	No	2	-	-	-	-
	1	Interpolation data read pointer position	UINT	RO	Yes	No	-	1	254	-	PnCF7 ^{*4}
	2	Interpolation data write pointer position	UINT	RO	Yes	No	-	1	254	-	PnCF8 ^{*4}
27C0h	Interpolation data record for 1st profile										
	0	Number of entries	DINT	RO	No	No	254	-	-	-	-
	1 to 254	1st set-point to 254 set-point	DINT	RW	No	No	0	-2147483648	2147483647	-	-

Continued on next page.

Continued from previous page.

Index	Sub-index	Name	Data Type	Access	PDO Mapping	Saving to EEPROM*1	Default Value	Lower Limit	Upper Limit	Unit	Parameter No.*2
27C1h	Interpolation data record for 2nd profile										
	0	Number of entries	DINT	RO	No	No	254	-	-	-	-
	1 to 254	1st set-point to 254 set-point	DINT	RW	No	No	0	-2147483648	2147483647	-	-
27E0h	-	Diag.mode	UINT	RW	No	No	0	0	0xFFFF	-	PnCfE
603Fh	0	Error code	UINT	RO	Yes	No	-	-	-	-	PnB10*4
6040h	0	Controlword	UINT	RW	Yes	No	0	0	0xFFFF	-	PnB11
6041h	0	Statusword	UINT	RO	Yes	No	-	-	-	-	PnB12*4
605Ah	0	Quick stop option code	INT	RW	No	Yes	2	0	4	-	PnB13
605Bh	0	Shutdown option code	INT	RW	No	Yes	0	0	1	-	PnB14
605Ch	0	Disable operation option code	INT	RW	No	Yes	1	0	1	-	PnB15
605Dh	0	Halt option code	INT	RW	No	Yes	1	0	4	-	PnB16
605Eh	0	Fault reaction option code	INT	RW	No	Yes	0	0	0	-	PnB17
6060h	0	Modes of operation	SINT	RW	Yes	Yes	0	0	10	-	PnB18
6061h	0	Modes of operation display	SINT	RO	Yes	No	0	-	-	-	PnB19*4
6062h	0	Position demand value	DINT	RO	Yes	No	-	-	-	Pos. unit	PnB20*4
6063h	0	Position actual internal value	DINT	RO	Yes	No	-	-	-	Inc	PnB22*4
6064h	0	Position actual value	DINT	RO	Yes	No	-	-	-	Pos. unit	PnB24*4
6065h	0	Following error window	UDINT	RW	No	Yes	5242880	0	1073741823	Pos. unit	PnB26
6066h	0	Following error time out	UINT	RW	No	Yes	0	0	65535	ms	PnB28
6067h	0	Position window	UDINT	RW	No	Yes	30	0	1073741823	Pos. unit	PnB2A
6068h	0	Position window time	UINT	RW	No	Yes	0	0	65535	ms	PnB2C
606Bh	0	Velocity demand value	DINT	RO	Yes	No	-	-	-	Vel. unit	PnB2E*4
606Ch	0	Velocity actual value	DINT	RO	Yes	No	-	-	-	Vel. unit	PnB30*4
606Dh	0	Velocity window	UINT	RW	No	Yes	20000	0	65535	Vel. unit	PnB32
606Eh	0	Velocity window time	UINT	RW	No	Yes	0	0	65535	ms	PnB34
6071h	0	Target torque	INT	RW	Yes	No	0	-32768	32767	Trq. unit	PnB36
6072h	0	Max torque	UINT	RW	Yes	No	Motor max torque	0	65535	Trq. unit	PnB38
6074h	0	Torque demand value	INT	RO	Yes	No	-	-	-	Trq. unit	PnB3A*4
6076h	0	Motor rated torque	UDINT	RO	No	No	-	-	-	mNm, mN	PnB3C*4
6077h	0	Torque actual value	INT	RO	Yes	No	-	-	-	Trq. unit	PnB3E*4
607Ah	0	Target position	DINT	RW	Yes	No	0	-2147483648	2147483647	Pos. unit	PnB40
607Ch	-	Home offset	DINT	RW	No	Yes	0	-536870912	536870911	Pos. unit	PnB46

Continued on next page.

Continued from previous page.

Index	Sub-index	Name	Data Type	Access	PDO Mapping	Saving to EEPROM ^{*1}	Default Value	Lower Limit	Upper Limit	Unit	Parameter No. ^{*2}
607Dh	Software position limit										
	0	Number of entries	USINT	RO	No	No	2	-	-	-	-
	1	Min position limit	DINT	RW	No	Yes	0	-536870912	536870911	Pos. unit	PnB48
	2	Max position limit	DINT	RW	No	Yes	0	-536870912	536870911	Pos. unit	PnB4A
607Fh	0	Max profile velocity	UDINT	RW	Yes	Yes	2147483647	0	4294967295	Vel. unit	PnB4C
6081h	0	Profile velocity	UDINT	RW	Yes	Yes	0	0	4294967295	Vel. unit	PnB4E
6083h	0	Profile acceleration	UDINT	RW	Yes	Yes	1000	0	4294967295	Acc. unit	PnB50
6084h	0	Profile deceleration	UDINT	RW	Yes	Yes	1000	0	4294967295	Acc. unit	PnB52
6085h	0	Quick stop deceleration	UDINT	RW	Yes	Yes	1000	0	4294967295	Acc. unit	PnB54
6086h	0	Motion profile type	INT	RW	Yes	Yes	0	-32768	32767	-	PnB98
6087h	0	Torque slope	UDINT	RW	Yes	Yes	1000	0	4294967295	Trq. unit/s	PnB56
6098h	0	Homing method	SINT	RW	Yes	No	35	0	35	-	PnB58
6099h	Homing speeds										
	0	Number of entries	USINT	RO	No	No	2	-	-	-	-
	1	Speed during search for switch	UDINT	RW	Yes	Yes	500000	0	4294967295	Vel. unit	PnB5A
	2	Speed during search for zero	UDINT	RW	Yes	Yes	100000	0	4294967295	Vel. unit	PnB5C
609Ah	0	Homing acceleration	UDINT	RW	Yes	Yes	1000	0	4294967295	Acc. unit	PnB5E
60A4h	Profile jerk										
	0	Number of entries	USINT	RO	No	No	1	-	-	-	-
	1	Profile jerk1	UDINT	RW	No	Yes	25	0	50	%	PnB9A
60B1h	0	Velocity offset	DINT	RW	Yes	No	0	-2147483648	2147483647	Vel. unit	PnB60
60B2h	0	Torque offset	INT	RW	Yes	No	0	-32768	32767	Trq. unit	PnB62
60B8h	0	Touch probe function	UINT	RW	Yes	No	0	0	0xFFFF	-	PnB64
60B9h	0	Touch probe status	UINT	RO	Yes	No	-	-	-	-	PnB66 ^{*4}
60BAh	0	Touch probe pos1 pos value	DINT	RO	Yes	No	-	-	-	Pos. unit	PnB68 ^{*4}
60BCh	0	Touch probe pos2 pos value	DINT	RO	Yes	No	-	-	-	Pos. unit	PnB6A ^{*4}
60C0h	0	Interpolation sub mode select	INT	RW	No	No	0	-3	0	-	PnB92
60C1h	Interpolation data record										
	0	Number of entries	USINT	RO	No	No	1	-	-	-	-
	1	Interpolation data record	DINT	RW	Yes	No	0	-2147483648	2147483647	Pos. unit	PnB70
60C2h	Interpolation time period										
	0	Number of entries	USINT	RO	No	No	2	-	-	-	-
	1	Interpolation time period	USINT	RW	No	No	125	1	250	-	PnB6E
	2	Interpolation time index	SINT	RW	No	No	-6	-6	-3	-	PnB6F
60E0h	0	Positive torque limit value	UINT	RW	Yes	Yes	8000	0	65535	Trq. unit	PnB80
60E1h	0	Negative torque limit value	UINT	RW	Yes	Yes	8000	0	65535	Trq. unit	PnB82

Continued on next page.

Continued from previous page.

Index	Subindex	Name	Data Type	Access	PDO Mapping	Saving to EEPROM*1	Default Value	Lower Limit	Upper Limit	Unit	Parameter No.*2
60E4h	0	Number of entries	USINT	RO	No	No	1	-	-	-	-
	1	Additional Position Actual Value	DINT	RO	Yes	No	0	-	-	-	-
60F4h	0	Following error actual value	DINT	RO	Yes	No	-	-	-	Pos. unit	PnB84*4
60FCh	0	Position demand internal value	DINT	RO	Yes	No	-	-	-	Inc	PnB86*4
60FDh	0	Digital inputs	UDINT	RO	Yes	No	-	-	-	-	PnB88*4
60FEh	Digital outputs										
	0	Number of entries	USINT	RO	No	No	2	-	-	-	-
	1	Physical outputs	UDINT	RW	Yes	No	0	0	0xFFFFFFFF	-	PnB8A
	2	Bit mask	UDINT	RW	No	Yes	0x000C0000	0	0xFFFFFFFF	-	PnB8C
60FFh	0	Target velocity	DINT	RW	Yes	No	0	-2147483648	2147483647	Vel. unit	PnB8E
6502h	0	Supported drive modes	UDINT	RO	No	No	0x03ED	-	-	-	PnB90*4

*1. Write "Save" to object 1010h to save all of the current parameter data to EEPROM.

If the objects are modified by the Digital Operator or SigmaWin+, the data will be directly saved in EEPROM.

*2. The parameter numbers given in the table are the parameter numbers that are used with the Digital Operator and SigmaWin+.

*3. These parameters cannot be written by the Digital Operator.

*4. These parameters are not displayed on the SigmaWin+.

*5. For SGD7S-□□□□E0: 0x02200301.

*6. Refer to the following section for details on the parameter.

 4.1.2 List of Parameters on page 4-3

Parameter numbers that are not on the list will not be displayed on the SigmaWin+ and Digital Operator.

4.3 SDO Abort Code List

The following table gives the SDO abort codes for SDO communications errors.

Value	Meaning
0x05 03 00 00	Toggle bit did not change.
0x05 04 00 00	SDO protocol timeout
0x05 04 00 01	Client/server command specifier is not valid or is unknown.
0x05 04 00 05	Out of memory
0x06 01 00 00	Unsupported access to an object
0x06 01 00 01	Attempt to read to a write-only object
0x06 01 00 02	Attempt to write to a read-only object
0x06 02 00 00	The object does not exist in the object directory.
0x06 04 00 41	The object cannot be mapped to the PDO.
0x06 04 00 42	The number and length of the objects to be mapped would exceed the PDO length.
0x06 04 00 43	General parameter incompatibility
0x06 04 00 47	General internal incompatibility in the device
0x06 06 00 00	Access failed due to a hardware error.
0x06 07 00 10	Data type does not match: length of service parameter does not match.
0x06 07 00 12	Data type does not match: service parameter too long.
0x06 07 00 13	Data type does not match: service parameter too short.
0x06 09 00 11	Subindex does not exist.
0x06 09 00 30	Value range of parameter was exceeded (only for write access).
0x06 09 00 31	Value of parameter that was written is too high.
0x06 09 00 32	Value of parameter that was written is too low.
0x06 09 00 36	The maximum value is less than the minimum value.
0x08 00 00 00	General error
0x08 00 00 20	Data cannot be transferred or stored to the application.
0x08 00 00 21	Data cannot be transferred or stored to the application because of local control.
0x08 00 00 22	Data cannot be transferred or stored to the application because of the present device state.

4.4

Parameter Recording Table

Use the following table to record the settings of the parameters.

Parameter No.	Default Setting						Name	When Enabled
Pn000 (2000h)	0000h						Basic Function Selections 0	After restart
Pn001 (2001h)	0000h						Application Function Selections 1	After restart
Pn002 (2002h)	0001h						Application Function Selections 2	After restart
Pn006 (2006h)	0002h						Application Function Selections 6	Immediately
Pn007 (2007h)	0000h						Application Function Selections 7	Immediately
Pn008 (2008h)	4000h						Application Function Selections 8	After restart
Pn009 (2009h)	0010h						Application Function Selections 9	After restart
Pn00A (200Ah)	0001h						Application Function Selections A	After restart
Pn00B (200Bh)	0000h						Application Function Selections B	After restart
Pn00C (200Ch)	0000h						Application Function Selections C	After restart
Pn00D (200Dh)	0000h						Application Function Selections D	Immediately
Pn00F (200Fh)	0000h						Application Function Selections F	After restart
Pn022 (2022h)	0000h						Application Function Selection 22	After restart
Pn081 (2081h)	0000h						Application Function Selections 81	After restart
Pn100 (2100h)	400						Speed Loop Gain	Immediately
Pn101 (2101h)	2000						Speed Loop Integral Time Constant	Immediately
Pn102 (2102h)	400						Position Loop Gain	Immediately
Pn103 (2103h)	100						Moment of Inertia Ratio	Immediately
Pn104 (2104h)	400						Second Speed Loop Gain	Immediately
Pn105 (2105h)	2000						Second Speed Loop Integral Time Constant	Immediately
Pn106 (2106h)	400						Second Position Loop Gain	Immediately
Pn109 (2109h)	0						Feedforward	Immediately
Pn10A (210Ah)	0						Feedforward Filter Time Constant	Immediately
Pn10B (210Bh)	0000h						Gain Application Selections	*
Pn10C (210Ch)	200						Mode Switching Level for Torque Reference	Immediately

Continued on next page.

Continued from previous page.

Parameter No.	Default Setting						Name	When Enabled
Pn10D (210Dh)	0						Mode Switching Level for Speed Reference	Immediately
Pn10E (210Eh)	0						Mode Switching Level for Acceleration	Immediately
Pn10F (210Fh)	0						Mode Switching Level for Position Deviation	Immediately
Pn11F (211Fh)	0						Position Integral Time Constant	Immediately
Pn121 (2121h)	100						Friction Compensation Gain	Immediately
Pn122 (2122h)	100						Second Friction Compensation Gain	Immediately
Pn123 (2123h)	0						Friction Compensation Coefficient	Immediately
Pn124 (2124h)	0						Friction Compensation Frequency Correction	Immediately
Pn125 (2125h)	100						Friction Compensation Gain Correction	Immediately
Pn131 (2131h)	0						Gain Switching Time 1	Immediately
Pn132 (2132h)	0						Gain Switching Time 2	Immediately
Pn135 (2135h)	0						Gain Switching Waiting Time 1	Immediately
Pn136 (2136h)	0						Gain Switching Waiting Time 2	Immediately
Pn139 (2139h)	0000h						Automatic Gain Switching Selections 1	Immediately
Pn13D (213Dh)	2000						Current Gain Level	Immediately
Pn140 (2140h)	0100h						Model Following Control-Related Selections	Immediately
Pn141 (2141h)	500						Model Following Control Gain	Immediately
Pn142 (2142h)	1000						Model Following Control Gain Correction	Immediately
Pn143 (2143h)	1000						Model Following Control Bias in the Forward Direction	Immediately
Pn144 (2144h)	1000						Model Following Control Bias in the Reverse Direction	Immediately
Pn145 (2145h)	500						Vibration Suppression 1 Frequency A	Immediately
Pn146 (2146h)	700						Vibration Suppression 1 Frequency B	Immediately
Pn147 (2147h)	1000						Model Following Control Speed Feedforward Compensation	Immediately
Pn148 (2148h)	500						Second Model Following Control Gain	Immediately
Pn149 (2149h)	1000						Second Model Following Gain Control Correction	Immediately
Pn14A (214Ah)	800						Vibration Suppression 2 Frequency	Immediately

Continued on next page.

Continued from previous page.

Parameter No.	Default Setting					Name	When Enabled
Pn14B (214Bh)	100					Vibration Suppression 2 Correction	Immediately
Pn14F (214Fh)	0021h					Control-Related Selections	After restart
Pn160 (2160h)	0010h					Anti-Resonance Control-Related Selections	Immediately
Pn161 (2161h)	1000					Anti-Resonance Frequency	Immediately
Pn162 (2162h)	100					Anti-Resonance Gain Correction	Immediately
Pn163 (2163h)	0					Anti-Resonance Damping Gain	Immediately
Pn164 (2164h)	0					Anti-Resonance Filter Time Constant 1 Correction	Immediately
Pn165 (2165h)	0					Anti-Resonance Filter Time Constant 2 Correction	Immediately
Pn166 (2166h)	0					Anti-Resonance Damping Gain 2	Immediately
Pn170 (2170h)	1401h					Tuning-less Function-Related Selections	*
Pn205 (2205h)	65535					Multiturn Limit	After restart
Pn207 (2207h)	0010h					Position Control Function Selections	After restart
Pn20A (220Ah)	32768					Number of External Scale Pitches	After restart
Pn20E (220Eh)	16					Electronic Gear Ratio (Numerator)	After restart
Pn210 (2210h)	1					Electronic Gear Ratio (Denominator)	After restart
Pn212 (2212h)	2048					Number of Encoder Output Pulses	After restart
Pn22A (222Ah)	0000h					Fully-closed Control Selections	After restart
Pn230 (2230h)	0000h					Position Control Expansion Function Selections	After restart
Pn231 (2231h)	0					Backlash Compensation	Immediately
Pn233 (2233h)	0					Backlash Compensation Time Constant	Immediately
Pn281 (2281h)	20					Encoder Output Resolution	After restart
Pn304 (2304h)	500					Jogging Speed	Immediately
Pn305 (2305h)	0					Soft Start Acceleration Time	Immediately
Pn306 (2306h)	0					Soft Start Deceleration Time	Immediately
Pn308 (2308h)	0					Speed Feedback Filter Time Constant	Immediately
Pn30A (230Ah)	0					Deceleration Time for Servo OFF and Forced Stops	Immediately
Pn30C (230Ch)	0					Speed Feedforward Average Movement Time	Immediately

Continued on next page.

Continued from previous page.

Parameter No.	Default Setting						Name	When Enabled
Pn310 (2310h)	0000h						Vibration Detection Selections	Immediately
Pn311 (2311h)	100						Vibration Detection Sensitivity	Immediately
Pn312 (2312h)	50						Vibration Detection Level	Immediately
Pn316 (2316h)	10000						Maximum Motor Speed	After restart
Pn324 (2324h)	300						Moment of Inertia Calculation Starting Level	Immediately
Pn401 (2401h)	100						First Stage First Torque Reference Filter Time Constant	Immediately
Pn402 (2402h)	800						Forward Torque Limit	Immediately
Pn403 (2403h)	800						Reverse Torque Limit	Immediately
Pn404 (2404h)	100						Forward External Torque Limit	Immediately
Pn405 (2405h)	100						Reverse External Torque Limit	Immediately
Pn406 (2406h)	800						Emergency Stop Torque	Immediately
Pn407 (2407h)	10000						Speed Limit during Torque Control	Immediately
Pn408 (2408h)	0000h						Torque-Related Function Selections	*
Pn409 (2409h)	5000						First Stage Notch Filter Frequency	Immediately
Pn40A (240Ah)	70						First Stage Notch Filter Q Value	Immediately
Pn40B (240Bh)	0						First Stage Notch Filter Depth	Immediately
Pn40C (240Ch)	5000						Second Stage Notch Filter Frequency	Immediately
Pn40D (240Dh)	70						Second Stage Notch Filter Q Value	Immediately
Pn40E (240Eh)	0						Second Stage Notch Filter Depth	Immediately
Pn40F (240Fh)	4000						Second Stage Second Torque Reference Filter Frequency	Immediately
Pn410 (2410h)	50						Second Stage Second Torque Reference Filter Q Value	Immediately
Pn412 (2412h)	100						First Stage Second Torque Reference Filter Time Constant	Immediately
Pn416 (2416h)	0000h						Torque-Related Function Selections 2	Immediately
Pn417 (2417h)	5000						Third Stage Notch Filter Frequency	Immediately
Pn418 (2418h)	70						Third Stage Notch Filter Q Value	Immediately
Pn419 (2419h)	0						Third Stage Notch Filter Depth	Immediately

Continued on next page.

Continued from previous page.

Parameter No.	Default Setting						Name	When Enabled
Pn41A (241Ah)	5000						Fourth Stage Notch Filter Frequency	Immediately
Pn41B (241Bh)	70						Fourth Stage Notch Filter Q Value	Immediately
Pn41C (241Ch)	0						Fourth Stage Notch Filter Depth	Immediately
Pn41D (241Dh)	5000						Fifth Stage Notch Filter Frequency	Immediately
Pn41E (241Eh)	70						Fifth Stage Notch Filter Q Value	Immediately
Pn41F (241Fh)	0						Fifth Stage Notch Filter Depth	Immediately
Pn423 (2423h)	0000h						Speed Ripple Compensation Selections	*
Pn424 (2424h)	50						Torque Limit at Main Circuit Voltage Drop	Immediately
Pn425 (2425h)	100						Release Time for Torque Limit at Main Circuit Voltage Drop	Immediately
Pn426 (2426h)	0						Torque Feedforward Average Movement Time	Immediately
Pn427 (2427h)	0						Speed Ripple Compensation Enable Speed	Immediately
Pn456 (2456h)	15						Sweep Torque Reference Amplitude	Immediately
Pn460 (2460h)	0101h						Notch Filter Adjustment Selections 1	Immediately
Pn475	0000h						Gravity Compensation-Related Selections	After restart
Pn476	0						Gravity Compensation Torque	Immediately
Pn502 (2502h)	20						Rotation Detection Level	Immediately
Pn503 (2503h)	10						Speed Coincidence Detection Signal Output Width	Immediately
Pn506 (2506h)	0						Brake Reference-Servo OFF Delay Time	Immediately
Pn507 (2507h)	100						Brake Reference Output Speed Level	Immediately
Pn508 (2508h)	50						Servo OFF-Brake Command Waiting Time	Immediately
Pn509 (2509h)	20						Momentary Power Interruption Hold Time	Immediately
Pn50A (250Ah)	1881h						Input Signal Selections 1	After restart
Pn50B (250Bh)	8882h						Input Signal Selections 2	After restart
Pn50E (250Eh)	0000h						Output Signal Selections 1	After restart
Pn50F (250Fh)	0100h						Output Signal Selections 2	After restart
Pn510 (2510h)	0000h						Output Signal Selections 3	After restart
Pn511 (2511h)	6543h						Input Signal Selections 5	After restart

Continued on next page.

Continued from previous page.

Parameter No.	Default Setting						Name	When Enabled
Pn512 (2512h)	0000h						Output Signal Inverse Settings	After restart
Pn514 (2514h)	0000h						Output Signal Selections 4	After restart
Pn516 (2516h)	8888h						Input Signal Selections 7	After restart
Pn51B (251Bh)	1000						Motor-Load Position Deviation Overflow Detection Level	Immediately
Pn51E (251Eh)	100						Position Deviation Overflow Warning Level	Immediately
Pn520 (2520h)	5242880						Position Deviation Overflow Alarm Level	Immediately
Pn522 (2522h)	7						Positioning Completed Width	Immediately
Pn524 (2524h)	1073741824						Near Signal Width	Immediately
Pn526 (2526h)	5242880						Position Deviation Overflow Alarm Level at Servo ON	Immediately
Pn528 (2528h)	100						Position Deviation Overflow Warning Level at Servo ON	Immediately
Pn529 (2529h)	10000						Speed Limit Level at Servo ON	Immediately
Pn52A (252Ah)	20						Multiplier per Fully-closed Rotation	Immediately
Pn52B (252Bh)	20						Overload Warning Level	Immediately
Pn52C (252Ch)	100						Base Current Derating at Motor Overload Detection	After restart
Pn530 (2530h)	0000h						Program Jogging-Related Selections	Immediately
Pn531 (2531h)	32768						Program Jogging Travel Distance	Immediately
Pn533 (2533h)	500						Program Jogging Movement Speed	Immediately
Pn534 (2534h)	100						Program Jogging Acceleration/Deceleration Time	Immediately
Pn535 (2535h)	100						Program Jogging Waiting Time	Immediately
Pn536 (2536h)	1						Program Jogging Number of Movements	Immediately
Pn550 (2550h)	0						Analog Monitor 1 Offset Voltage	Immediately
Pn551 (2551h)	0						Analog Monitor 2 Offset Voltage	Immediately
Pn552 (2552h)	100						Analog Monitor 1 Magnification	Immediately
Pn553 (2553h)	100						Analog Monitor 2 Magnification	Immediately
Pn55A (255Ah)	1						Power Consumption Monitor Unit Time	Immediately
Pn560 (2560h)	400						Residual Vibration Detection Width	Immediately
Pn561 (2561h)	100						Overshoot Detection Level	Immediately

Continued on next page.

Continued from previous page.

Parameter No.	Default Setting						Name	When Enabled
Pn600 (2600h)	0						Regenerative Resistor Capacity	Immediately
Pn601 (2601h)	0						Dynamic Brake Resistor Capacity	Immediately
Pn603 (2603h)	0						Regenerative Resistance	Immediately
Pn604 (2604h)	0						Dynamic Brake Resistance	Immediately
Pn61A (261Ah)	0000h						Overheat Protection Selections	After restart
Pn61B (261Bh)	250						Overheat Alarm Level	Immediately
Pn61C (261Ch)	100						Overheat Warning Level	Immediately
Pn61D (261Dh)	0						Overheat Alarm Filter Time	Immediately

* The timing for enabling changes to parameter settings depends on the parameter. Refer to the following section for details on the enable timing.

 4.1 List of Parameters on page 4-2

Index

A

alarm reset possibility - - - - - 3-2

B

base block (BB) - - - - - xii

C

CiA402 drive profile- - - - - 2-7

coefficient of speed fluctuation - - - - - 2-8

communications connectors - - - - - 2-7

compliant communications standards - - - - - 2-7

D

distributed clocks- - - - - 2-7

drive profile - - - - - 2-7

E

EtherCAT commands- - - - - 2-7

EtherCAT communications - - - - - 2-7

F

FMMU - - - - - 2-7

I

indicators - - - - - 2-7

L

list of alarms- - - - - 3-2

list of parameters - - - - - 4-2

list of warnings - - - - - 3-32

M

mailbox - - - - - 2-7

Main Circuit Cable - - - - - xii

O

object list - - - - - 4-26

P

parameter settings recording table - - - - - 4-35

parameters

 notation (numeric settings) - - - - - xiii

 notation (selecting functions) - - - - - xiii

physical layer - - - - - 2-7

process data - - - - - 2-7

S

Servo Drive - - - - - xii

servo lock - - - - - xii

servo OFF - - - - - xii

servo ON - - - - - xii

Servo System- - - - - xii

Servomotor - - - - - xii

SERVOPACK - - - - - xii

 ratings- - - - - -2-2

 specifications- - - - - -2-5

SigmaWin+ - - - - - xii

storage humidity - - - - - -2-5

storage temperature - - - - - -2-5

SubDevice Information IF - - - - - -2-7

surrounding air humidity - - - - - -2-5

surrounding air temperature - - - - - -2-5

Sync manager - - - - - -2-7

T

troubleshooting alarms - - - - - -3-8

troubleshooting warnings - - - - - -3-34

Revision History

The revision dates and numbers of the revised manuals are given on the bottom of the back cover.

MANUAL NO. SIEP S800002 26B <1>-1
 Published in Japan December 2017

└── Web revision number
 └── Revision number
 └── Date of publication

Date of Publication	Rev. No.	Web Rev. No.	Section	Revised Contents
April 2026	<12>	0	Preface, 1.6.2, 2.3, 3.1.2	Partly revised.
			Back cover	Revision: Address
November 2024	<11>	0	3.1.2, 4.1.2, 4.4	Partly revised.
April 2024	<10>	0	Preface, 2.3	Partly revised.
September 2023	<9>	0	2.1.1, 2.1.2, 2.1.3, 3.1.2	Partly revised.
			Back cover	Revision: Address
February 2023	<8>	0	Preface, 1.2, 3.1.2	Partly revised.
			Back cover	Revision: Address
February 2022	<7>	0	Preface, 1.6.1, 4.2	Partly revised.
			Back cover	Revision: Address
September 2021	<6>	0	All chapters	Partly revised.
August 2020	<5>	0	Preface	Partly revised.
February 2020	<4>	0	Preface	Partly revised.
			4.1.2	Revision: Setting Range of Pn00A (200Ah)
			Back cover	Revision: Address
October 2019	<3>	0	All chapters	Partly revised.
			Back cover	Revision: Address
October 2018	<2>	0	Preface	Partly revised.
			1.6	Newly added.
			4.2	Addition: Footnote 4
			Back cover	Revision: Address
December 2017	<1>	0	Preface	Partly revised
			Chapter 3	Deletion: F50h
			4.1, 4.4	Addition: Pn022 (2022h)
August 2017	-	-	-	First edition

Σ-7-Series AC Servo Drive Σ-7S SERVOPACK with FT/EX Specification for Application with Special Motor, SGM7D Motor Product Manual

IRUMA BUSINESS CENTER (SOLUTION CENTER)

480, Kamifujisawa, Iruma, Saitama, 358-8555, Japan
Phone: +81-4-2962-5151 Fax: +81-4-2962-6138
www.yaskawa.co.jp

YASKAWA AMERICA, INC.

2121, Norman Drive South, Waukegan, IL 60085, U.S.A.
Phone: +1-800-YASKAWA (927-5292) or +1-847-887-7000 Fax: +1-847-887-7310
www.yaskawa.com

YASKAWA ELÉTRICO DO BRASIL LTDA.

777, Avenida Piraporinha, Diadema, São Paulo, 09950-000, Brasil
Phone: +55-11-3585-1100 Fax: +55-11-3585-1187
www.yaskawa.com.br

YASKAWA EUROPE GmbH

Philipp-Reis-Str. 6, 65795 Hattersheim am Main, Germany
Phone: +49-6196-569-300
www.yaskawa.eu.com E-mail: support@yaskawa.eu

YASKAWA ELECTRIC KOREA CORPORATION

6F, 112, LS-ro, Dongan-gu, Anyang-si, Gyeonggi-do, Korea
Phone: +82-31-8015-4224 Fax: +82-31-8015-5034
www.yaskawa.co.kr

YASKAWA ASIA PACIFIC PTE. LTD.

30A, Kallang Place, #06-01, 339213, Singapore
Phone: +65-6282-3003 Fax: +65-6289-3003
www.yaskawa.com.sg

YASKAWA ELECTRIC (THAILAND) CO., LTD.

59, 1F-5F, Flourish Building, Soi Ratchadapisek 18, Ratchadapisek Road, Huaykwang, Bangkok, 10310, Thailand
Phone: +66-2-017-0099 Fax: +66-2-017-0799
www.yaskawa.co.th

YASKAWA ELECTRIC (CHINA) CO., LTD.

22F, Link Square 1, No.222, Hubin Road, Shanghai, 200021, China
Phone: +86-21-5385-2200 Fax: +86-21-5385-3299
www.yaskawa.com.cn

YASKAWA ELECTRIC (CHINA) CO., LTD. BEIJING OFFICE

Room 1011, Tower W3 Oriental Plaza, No.1, East Chang An Avenue,
Dong Cheng District, Beijing, 100738, China
Phone: +86-10-8518-4086 Fax: +86-10-8518-4082

YASKAWA ELECTRIC TAIWAN CORPORATION

12F, No. 207, Section 3, Beishin Road, Shindian District, New Taipei City 23143, Taiwan
Phone: +886-2-8913-1333 Fax: +886-2-8913-1513 or +886-2-8913-1519
www.yaskawa.com.tw

YASKAWA

YASKAWA ELECTRIC CORPORATION

In the event that the end user of this product is to be the military and said product is to be employed in any weapons systems or the manufacture thereof, the export will fall under the relevant regulations as stipulated in the Foreign Exchange and Foreign Trade Act. Therefore, be sure to follow all procedures and submit all relevant documentation according to any and all rules, regulations and laws that may apply. Specifications are subject to change without notice for ongoing product modifications and improvements.

© 2017 YASKAWA ELECTRIC CORPORATION

MANUAL NO. SIEP S800002 26M <12>-0

Published in Japan April 2026

25-9-21

Original instructions