



# YASKAWA AC Drive A1000

## High Performance Vector Control Drive

### Safety Precautions

Type: CIMR-AU□ A

Models: 200 V Class: 3/4 to 175 HP ND

400 V Class: 3/4 to 1000 HP ND

600 V Class: 1 to 250 HP ND

To properly use the product, read these precautions and refer to the CD-ROM packaged with the product. Ensure the end user receives these precautions and the CD-ROM No. TOECC71061615.

Copyright © 2013 YASKAWA ELECTRIC CORPORATION. All rights reserved.

No part of this publication may be reproduced, stored in a retrieval system, or transmitted, in any form or by any means, mechanical, electronic, photocopying, recording, or otherwise, without the prior written permission of Yaskawa. No patent liability is assumed with respect to the use of the information contained herein. Moreover, because Yaskawa is constantly striving to improve its high-quality products, the information contained in this manual is subject to change without notice. Every precaution has been taken in the preparation of this manual. Yaskawa assumes no responsibility for errors or omissions. Neither is any liability assumed for damages resulting from the use of the information contained in this publication.

# A1000 Safety Precautions

---

This document provides essential safety information for the A1000 series AC drive. Refer to the A1000 Quick Start Procedure TM.A1000.01 packaged with the drive to configure the drive for basic operation. Refer to the CD-ROM packaged with the product for complete product instructions necessary for proper installation, set-up, troubleshooting and maintenance. CD part number TOECC71061615. The 1000 Series CD-ROM contains the A1000 Technical Manual No. SIEPC71061641 and additional 1000 Series manuals.

<b>i.1</b>	<b>GENERAL SAFETY.....</b>	<b>5</b>
<b>i.2</b>	<b>MECHANICAL INSTALLATION SAFETY.....</b>	<b>9</b>
<b>i.3</b>	<b>ELECTRICAL INSTALLATION SAFETY.....</b>	<b>15</b>
<b>i.4</b>	<b>TROUBLESHOOTING.....</b>	<b>44</b>
<b>i.5</b>	<b>UL AND CSA STANDARDS.....</b>	<b>46</b>
<b>i.6</b>	<b>EUROPEAN STANDARDS.....</b>	<b>54</b>
<b>i.7</b>	<b>REVISION HISTORY.....</b>	<b>68</b>

---

## ◆ Applicable Models

This Safety Precautions document applies to the drive models in *Table i.1*.

**Table i.1 Applicable Models**

Drive Series	Drive Model Number	Software Version
A1000	CIMR-AU2□□□□□	All
	CIMR-AU4□□□□□	
	CIMR-AU5□□□□□	All

---

## ◆ Warranty Information

### ■ Restrictions

The drive is not designed or manufactured for use in devices or systems that may directly affect or threaten human lives or health.

Customers who intend to use the product described in this manual for devices or systems relating to transportation, health care, space aviation, atomic power, electric power, or in underwater applications must first contact their Yaskawa representatives or the nearest Yaskawa sales office.

**WARNING!** *Injury to Personnel. This product has been manufactured under strict quality-control guidelines. However, if this product is to be installed in any location where failure of this product could involve or result in a life-and-death situation or loss of human life or in a facility where failure may cause a serious accident or physical injury, safety devices must be installed to minimize the likelihood of any accident.*

## i.1 General Safety

### ◆ Supplemental Safety Information

#### General Precautions

- The diagrams in this manual may be indicated without covers or safety shields to show details. Replace the covers or shields before operating the drive and run the drive according to the instructions described in this manual.
- Any illustrations, photographs, or examples used in this manual are provided as examples only and may not apply to all products to which this manual is applicable.
- The products and specifications described in this manual or the content and presentation of the manual may be changed without notice to improve the product and/or the manual.
- When ordering a new copy of the manual due to damage or loss, contact your Yaskawa representative or the nearest Yaskawa sales office and provide the manual number shown on the front cover.
- If nameplate becomes worn or damaged, order a replacement from your Yaskawa representative or the nearest Yaskawa sales office.

#### WARNING

Read and understand this manual before installing, operating or servicing this drive. The drive must be installed according to this manual and local codes.

The following conventions are used to indicate safety messages in this manual. Failure to heed these messages could result in serious or fatal injury or damage to the products or to related equipment and systems.

#### DANGER

Indicates a hazardous situation, which, if not avoided, will result in death or serious injury.

#### WARNING

Indicates a hazardous situation, which, if not avoided, could result in death or serious injury.

**WARNING!** *may also be indicated by a bold key word embedded in the text followed by an italicized safety message.*

#### CAUTION

Indicates a hazardous situation, which, if not avoided, could result in minor or moderate injury.

**CAUTION!** *may also be indicated by a bold key word embedded in the text followed by an italicized safety message.*

#### NOTICE

Indicates a property damage message.

**NOTICE:** *may also be indicated by a bold key word embedded in the text followed by an italicized safety message.*

### ◆ Safety Messages

#### DANGER

**Heed the safety messages in this manual.**

Failure to comply will result in death or serious injury.

The operating company is responsible for any injuries or equipment damage resulting from failure to heed the warnings in this manual.

### DANGER

#### Electrical Shock Hazard

**Do not connect or disconnect wiring while the power is on.**

Failure to comply will result in death or serious injury.

Before servicing, disconnect all power to the equipment. The internal capacitor remains charged even after the power supply is turned off. After shutting off the power, wait for at least the amount of time specified on the drive before touching any components.

### WARNING

#### Sudden Movement Hazard

**System may start unexpectedly upon application of power, resulting in death or serious injury.**

Clear all personnel from the drive, motor and machine area before applying power. Secure covers, couplings, shaft keys and machine loads before applying power to the drive.

**When using DriveWorksEZ to create custom programming, the drive I/O terminal functions change from factory settings and the drive will not perform as outlined in this manual.**

Unpredictable equipment operation may result in death or serious injury.

Take special note of custom I/O programming in the drive before attempting to operate equipment.

#### Electrical Shock Hazard

**Do not attempt to modify or alter the drive in any way not explained in this manual.**

Failure to comply could result in death or serious injury.

Yaskawa is not responsible for any modification of the product made by the user. This product must not be modified.

**Do not allow unqualified personnel to use equipment.**

Failure to comply could result in death or serious injury.

Maintenance, inspection, and replacement of parts must be performed only by authorized personnel familiar with installation, adjustment and maintenance of AC drives.

**Do not remove covers or touch circuit boards while the power is on.**

Failure to comply could result in death or serious injury.

**Make sure the protective earthing conductor complies with technical standards and local safety regulations.**

Because the leakage current exceeds 3.5 mA in models 4A0414 and larger, IEC/EN 61800-5-1 states that either the power supply must be automatically disconnected in case of discontinuity of the protective earthing conductor or a protective earthing conductor with a cross-section of at least 10 mm<sup>2</sup> (Cu) or 16 mm<sup>2</sup> (Al) must be used. Failure to comply may result in death or serious injury.

**Always use appropriate equipment for Ground Fault Circuit Interrupters (GFCIs).**

The drive can cause a residual current with a DC component in the protective earthing conductor. Where a residual current operated protective or monitoring device is used for protection in case of direct or indirect contact, always use a type B GFCI according to IEC/EN 60755.

#### Fire Hazard

**Do not use an improper voltage source.**

Failure to comply could result in death or serious injury by fire.

Verify that the rated voltage of the drive matches the voltage of the incoming power supply before applying power.

**Install adequate branch circuit protection according to applicable local codes and this Installation Manual. Failure to comply could result in fire and damage to the drive or injury to personnel.**

The device is suitable for use on a circuit capable of delivering not more than 100,000 RMS symmetrical amperes, 240 Vac maximum (200 V class) and 480 Vac maximum (400 V class), and 600 Vac maximum (600 V class) when protected by branch circuit protection devices specified in this document.

**⚠ WARNING****Crush Hazard**

**Do not use this drive in lifting applications without installing external safety circuitry to prevent accidental dropping of the load.**

**The drive does not possess built-in load drop protection for lifting applications.**

Failure to comply could result in death or serious injury from falling loads.

Install electrical and/or mechanical safety circuit mechanisms independent of drive circuitry.

**⚠ CAUTION****Crush Hazard**

**Do not carry the drive by the front cover.**

Failure to comply may result in minor or moderate injury from the main body of the drive falling.

**NOTICE**

**Observe proper electrostatic discharge procedures (ESD) when handling the drive and circuit boards.**

Failure to comply may result in ESD damage to the drive circuitry.

**Do not perform a withstand voltage test on any part of the drive.**

Failure to comply could result in damage to the sensitive devices within the drive.

**Do not operate damaged equipment.**

Failure to comply could result in further damage to the equipment.

Do not connect or operate any equipment with visible damage or missing parts.

**If a fuse is blown or a Ground Fault Circuit Interrupter (GFCI) is tripped, check the wiring and the selection of the peripheral devices.**

Contact your supplier if the cause cannot be identified after checking the above.

**Do not restart the drive immediately operate the peripheral devices if a fuse is blown or a GFCI is tripped.**

Check the wiring and the selection of peripheral devices to identify the cause. Contact your supplier before restarting the drive or the peripheral devices if the cause cannot be identified.

**Do not expose the drive to halogen group disinfectants.**

Failure to comply may cause damage to the electrical components in the drive.

Do not pack the drive in wooden materials that have been fumigated or sterilized.

Do not sterilize the entire package after the product is packed.

## i.1 General Safety

---

### ◆ Periodic Maintenance Safety

**WARNING! Electrical Shock Hazard.** Capacitors in the drive do not immediately discharge after shutting off the power. Wait for at least the amount of time specified on the drive before touching any components after shutting off the power. Failure to comply may cause injury to personnel from electrical shock.

**WARNING! Burn Hazard.** Because the heatsink can get very hot during operation, take proper precautions to prevent burns. When replacing the cooling fan, shut off the power and wait at least 15 minutes to be sure that the heatsink has cooled down. Failure to comply may cause burn injury to personnel.

---

### ◆ Motor Application Safety

**WARNING! Electrical Shock Hazard.** When a drive is running a PM motor, voltage continues to be generated at the motor terminals after the drive is shut off while the motor coasts to stop. Take the precautions described below to prevent shock and injury:

- In applications where the machine can still rotate after the drive has fully stopped a load, install a switch to the drive output side to disconnect the motor and the drive.
- Do not allow an external force to rotate the motor beyond the maximum allowable speed or to rotate the motor when the drive has been shut off.
- Wait for at least the time specified on the warning label after opening the load switch on the output side before inspecting the drive or performing any maintenance.
- Do not open and close the load switch while the motor is running.
- If the motor is coasting, make sure the power to the drive is turned on and the drive output has completely stopped before closing the load switch.

**NOTICE: Equipment Damage.** A motor connected to a PWM drive may operate at a higher temperature than a utility-fed motor and the operating speed range may reduce motor cooling capacity. Ensure that the motor is suitable for drive duty and/or the motor service factor is adequate to accommodate the additional heating with the intended operating conditions.

#### Insulation Tolerance

**NOTICE:** Consider motor voltage tolerance levels and motor insulation in applications with an input voltage of over 440 V or particularly long wiring distances.

#### High-Speed Operation

**NOTICE:** Problems may occur with the motor bearings and dynamic balance of the machine when operating a motor beyond its rated speed. Contact the motor or machine manufacturer.

#### Torque Characteristics

Torque characteristics differ compared to operating the motor directly from line power. The user should have a full understanding of the load torque characteristics for the application.

#### Audible Noise

The audible noise of the motor varies based on the carrier frequency setting. However, drive current derating may be required. When using a high carrier frequency, audible noise from the motor is comparable to the motor noise generated when running from line power.

---

### ◆ Receiving Safety

#### ⚠ CAUTION

**Do not carry the drive by the front cover or the terminal cover.**

Failure to comply may cause the main body of the drive to fall, resulting in minor or moderate injury.

#### NOTICE

**Observe proper electrostatic discharge procedures (ESD) when handling the drive and circuit boards.**

Failure to comply may result in ESD damage to the drive circuitry.

---

#### Transporting the Drive

**NOTICE:** Never steam clean the drive. During transport, keep the drive from coming into contact with salts, fluorine, bromine, phthalate ester, and other such harmful chemicals.



## i.2 Mechanical Installation Safety

### WARNING

#### Fire Hazard

**Provide sufficient cooling when installing the drive inside an enclosed panel or cabinet.**

Failure to comply could result in overheating and fire.

When multiple drives are placed inside the same enclosure panel, install proper cooling to ensure air entering the enclosure does not exceed 40 °C.

#### Crush Hazard

**Only allow qualified personnel to operate a crane or hoist to transport the drive.**

Failure to comply may result in serious injury or death from falling equipment.

**Use a dedicated lifter when transporting the drive by a lifter.**

Failure to comply may result in serious injury or death from falling equipment.

**Only use vertical suspension to temporarily lift the drive during installation to an enclosure panel. Do not use vertical suspension to transport the drive.**

Failure to comply may result in serious injury or death from falling equipment.

**Use screws to securely affix the drive front cover, terminal blocks, and other drive components prior to vertical suspension.**

Failure to comply may result in serious injury or death from falling equipment.

**Do not subject the drive to vibration or impact greater than 1.96 m/s<sup>2</sup> (0.2 G) while it is suspended by the cables.**

Failure to comply may result in serious injury or death from falling equipment.

**Do not attempt to flip the drive over or leave the drive unattended while it is suspended by the wires.**

Failure to comply may result in serious injury or death from falling equipment.

### NOTICE

#### Equipment Hazard

**Prevent foreign matter such as metal shavings or wire clippings from falling into the drive during drive installation and project construction.**

Failure to comply could result in damage to the drive. Place a temporary cover over the top during installation. Be sure to remove the temporary cover before start-up, as the cover will reduce ventilation and cause the unit to overheat.

**Observe proper electrostatic discharge (ESD) procedures when handling the drive.**

Failure to comply could result in ESD damage to the drive circuitry.

**When the input voltage is 440 V or higher or the wiring distance is greater than 100 meters, pay special attention to the motor insulation voltage or use a drive-rated motor with reinforced insulation.**

Failure to comply could lead to motor winding failure.

**Never lift the drive up while the cover is removed.**

This can damage the terminal board and other components.

### ◆ Installation Environment

Install the drive in an environment matching the specifications in [Table i.2](#) to help prolong the optimum performance life of the drive.

**Table i.2 Installation Environment**

Environment	Conditions
<b>Installation Area</b>	Indoors
<b>Ambient Temperature</b>	IP20/NEMA Type 1 enclosure: -10 °C to +40 °C (14 °F to 104 °F) IP00/Open Type enclosure: -10 °C to +50 °C (14 °F to 122 °F) Drive reliability improves in environments without wide temperature fluctuations. When using the drive in an enclosure panel, install a cooling fan or air conditioner in the area to ensure that the air temperature inside the enclosure does not exceed the specified levels. Do not allow ice to develop on the drive.
<b>Humidity</b>	95% RH or less and free of condensation
<b>Storage Temperature</b>	-20 °C to +60 °C (-4 °F to +104 °F)
<b>Surrounding Area</b>	Install the drive in an area free from: <ul style="list-style-type: none"> <li>• oil mist and dust</li> <li>• metal shavings, oil, water, or other foreign materials</li> <li>• radioactive materials</li> <li>• combustible materials (e.g., wood)</li> <li>• harmful gases and liquids</li> <li>• excessive vibration</li> <li>• chlorides</li> <li>• direct sunlight.</li> </ul>
<b>Altitude</b>	1000 m (3281 ft.) or lower, up to 3000 m (9843 ft.) with derating
<b>Vibration</b>	10 to 20 Hz at 9.8 m/s <sup>2</sup> (32.15 ft/s <sup>2</sup> ) <1> 20 to 55 Hz at 5.9 m/s <sup>2</sup> (19.36 ft/s <sup>2</sup> ) (Models 2A0004 to 2A0211, 4A0002 to 4A0165, and 5A0003 to 5A0099) or 2.0 m/s <sup>2</sup> (6.56 ft/s <sup>2</sup> ) (Models 2A0250 to 2A0415, 4A0208 to 4A1200, and 5A0125 to 5A0242)
<b>Orientation</b>	Install the drive vertically to maintain maximum cooling effects.

<1> Models 4A0930 and 4A1200 are rated at 5.9 m/s<sup>2</sup> (19.36 ft/s<sup>2</sup>)

**NOTICE:** Avoid placing drive peripheral devices, transformers, or other electronics near the drive as the noise created can lead to erroneous operation. If such devices must be used in close proximity to the drive, take proper steps to shield the drive from noise.

**NOTICE:** Prevent foreign matter such as metal shavings and wire clippings from falling into the drive during installation. Failure to comply could result in damage to the drive. Place a temporary cover over the top of the drive during installation. Remove the temporary cover before drive start-up, as the cover will reduce ventilation and cause the drive to overheat.

## ◆ Instructions on Installation Using the Eye Bolts

Eye bolts are used to install the drive or to temporarily lift the drive when replacing it. Using the eye bolts, the drive can be installed in an enclosure panel or on a wall. Do not leave the drive suspended by the wires in a horizontal or vertical position for long periods of time. Do not transport the drive over long distances. Read the following precautions and instructions before installing the drive.

**WARNING! Crush Hazard.** Observe the following instructions and precautions. Failure to comply could result in serious injury or death from falling equipment.

Only use vertical suspension to temporarily lift the drive during installation to an enclosure panel. Do not use vertical suspension to transport the drive.

Use screws to securely affix the drive front cover, terminal blocks, and other drive components prior to vertical suspension.

### ■ Horizontal Suspension of Drive Models 2A0360, 2A0415, and 4A0250 to 4A0675

To make a wire hanger or frame for use when lifting the drive with a crane, lay the drive in a horizontal position and pass a wire through the holes of the four eye bolts.

**NOTICE: Damage to Equipment.** When lifting the drive, confirm that the spring washer is fully closed. Failure to comply may deform or damage the drive when lifted.

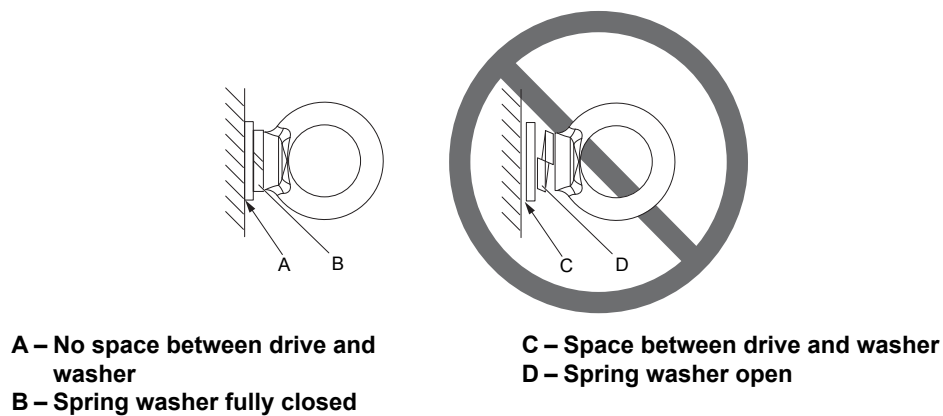

Figure i.1 Spring Washer

### ■ Vertical Suspension of Drive Models 2A0360, 2A0415, and 4A0250 to 4A1200

#### Models 2A0360, 2A0415, and 4A0250 to 4A0675

When vertical suspension of the drive is required in an enclosure panel, change the orientation of the eye bolts for these models by turning the eye bolts counterclockwise 90 degrees.

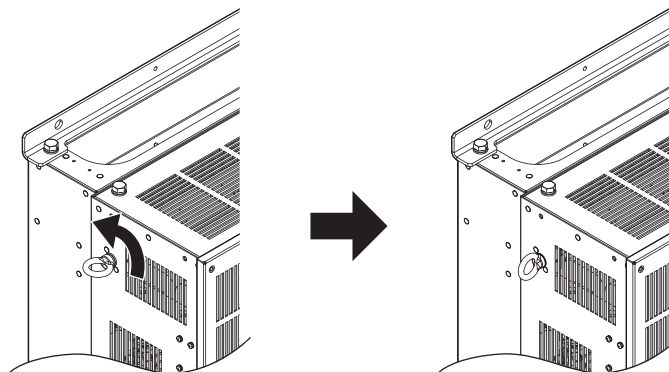

Figure i.2 Adjusting Angle of Eye Bolts

#### Models 4A0930 and 4A1200

When suspending models 4A0930 or 4A1200 with wires, follow the procedure described below.

## i.2 Mechanical Installation Safety

**WARNING! Crush Hazard.** Use an adequate length of wire to ensure a 50° or wider suspension angle as illustrated in [Figure i.4](#). The maximum allowable load of the eye bolts cannot be guaranteed when the drive is suspended with the wires at angles less than 50°. Failure to comply may result in serious injury or death from falling equipment.

1. Remove the four eye bolts from the drive side panels and fix them securely on the top panel.

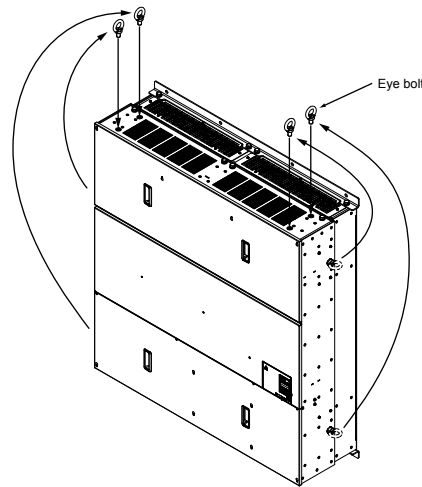
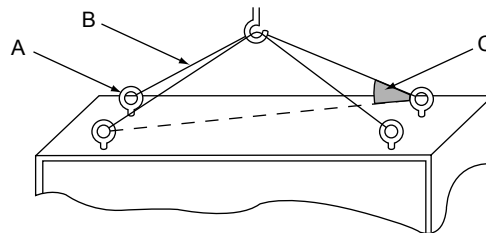

Figure i.3 Eye Bolt Repositioning

2. Pass wire through the holes of all four eye bolts.



A – Eye bolt  
B – Wires

C – Suspending angle: 50° or greater

Figure i.4 Suspension Wire Angle Example

3. Gradually take up the slack in the wires and hoist the drive after the wires are stretched tight.
4. Lower the drive when ready to install in the enclosure panel. Stop lowering the drive when it is near the floor then begin lowering the drive again very slowly until the drive is placed correctly.

## ◆ Installation Orientation and Spacing

Install the drive upright as illustrated in [Figure i.5](#) to maintain proper cooling.

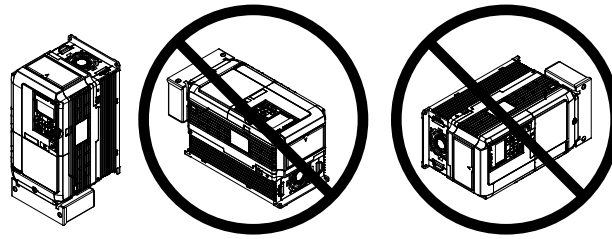

Figure i.5 Correct Installation Orientation

**NOTICE:** Install the drive upright as specified in the manual. Failure to comply may damage the drive due to improper cooling.

**NOTICE:** Install the drive upright as specified in the manual. Failure to comply may damage the drive due to improper cooling.

## ■ Single Drive Installation

[Figure i.6](#) shows the installation distance required to maintain sufficient space for airflow and wiring. Install the heatsink against a closed surface to avoid diverting cooling air around the heatsink.

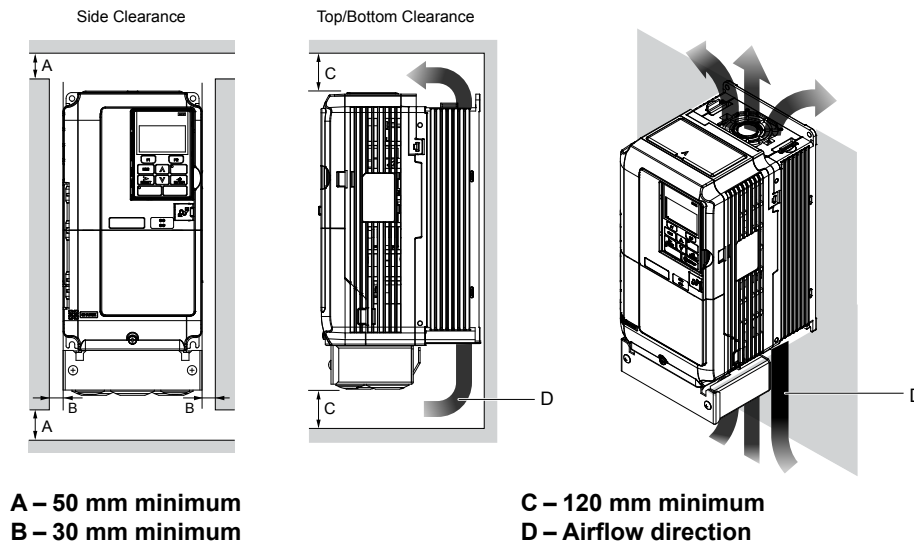

Figure i.6 Correct Installation Spacing

**Note:** IP20/NEMA Type 1 enclosure and IP00/Open Type enclosure models require the same amount of space above and below the drive for installation.

## ■ Multiple Drive Installation (Side-by-Side Installation)

Models 2A0004 to 2A0081, 4A0002 to 4A0044, and 5A0003 to 5A0032 can take advantage of Side-by-Side installation.

When installing multiple drives into the same enclosure panel, mount the drives according to [Figure i.6](#) and set L8-35, Installation Method Selection, to 1 (Side-by-Side Mounting).

When mounting drives with the minimum clearance of 2 mm according to [Figure i.7](#), set parameter L8-35 to 1 while considering derating.

## i.2 Mechanical Installation Safety

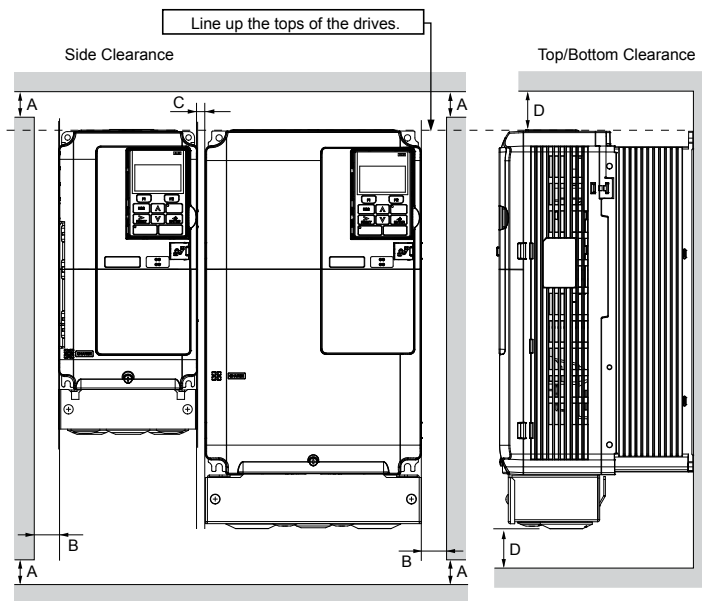

**A** – 50 mm minimum  
**B** – 30 mm minimum

**C** – 2 mm minimum  
**D** – 120 mm minimum

**Figure i.7 Space Between Drives (Side-by-Side Mounting)**

**Note:** Align the tops of the drives when installing drives of different heights in the same enclosure panel. Leave space between the tops and bottoms of stacked drives for easier cooling fan replacement.

Remove the top protective covers of all drives as shown in [Figure i.8](#) when mounting IP20/NEMA Type 1 enclosure drives side-by-side.

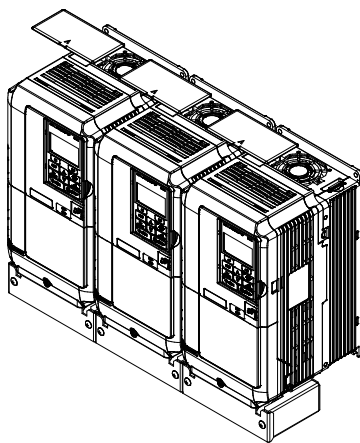

**Figure i.8 IP20/NEMA 1 Side-by-Side Mounting in Enclosure**

### ◆ Drive Dimensions

#### NOTICE

Refer to the A1000 Technical Manual SIEPC71061641 for IP20/NEMA Type 1, IP00/Open Chassis and Flange Type Enclosure (NEMA 12 Backside) drive dimensions.

The 1000 Series CD-ROM No. TOECC71061615, packaged with the drive contains the A1000 Technical Manual No. SIEPC71061641 and additional 1000 Series manuals.

## i.3 Electrical Installation Safety

### NOTICE

Refer to the A1000 Technical Manual SIEPC71061641 on the CD-ROM packaged with the product for more information regarding the *Electrical Installation* and for complete product instructions necessary for proper installation, set-up, troubleshooting and maintenance. CD-ROM part number TOECC71061615.

### DANGER

#### Electrical Shock Hazard

**Do not connect or disconnect wiring while the power is on.**

Failure to comply will result in death or serious injury.

### WARNING

#### Electrical Shock Hazard

**Make sure the protective earthing conductor complies with technical standards and local safety regulations.**

Because the leakage current exceeds 3.5 mA in models 4A0414 and larger, IEC/EN 61800-5-1 states that either the power supply must be automatically disconnected in case of discontinuity of the protective earthing conductor or a protective earthing conductor with a cross-section of at least 10 mm<sup>2</sup> (Cu) or 16 mm<sup>2</sup> (Al) must be used. Failure to comply may result in death or serious injury.

**Always use appropriate equipment for Ground Fault Circuit Interrupters (GFCIs).**

The drive can cause a residual current with a DC component in the protective earthing conductor. Where a residual current operated protective or monitoring device is used for protection in case of direct or indirect contact, always use a type B GFCI according to IEC/EN 60755.

### WARNING

#### Electrical Shock Hazard

**Do not operate equipment with covers removed.**

Failure to comply could result in death or serious injury.

The diagrams in this section may show drives without covers or safety shields to show details. Be sure to reinstall covers or shields before operating the drives and run the drives according to the instructions described in this manual.

**Always ground the motor-side grounding terminal.**

Improper equipment grounding could result in death or serious injury by contacting the motor case.

**Do not perform work on the drive while wearing loose clothing, jewelry or without eye protection.**

Failure to comply could result in death or serious injury.

Remove all metal objects such as watches and rings, secure loose clothing, and wear eye protection before beginning work on the drive.

**Do not remove covers or touch circuit boards while the power is on.**

Failure to comply could result in death or serious injury.

**Do not allow unqualified personnel to perform work on the drive.**

Failure to comply could result in death or serious injury.

Installation, maintenance, inspection, and servicing must be performed only by authorized personnel familiar with installation, adjustment, and maintenance of AC drives.

#### **WARNING**

**Do not touch any terminals before the capacitors have fully discharged.**

Failure to comply could result in death or serious injury.

Before wiring terminals, disconnect all power to the equipment. The internal capacitor remains charged even after the power supply is turned off. After shutting off the power, wait for at least the amount of time specified on the drive before touching any components.

#### **Fire Hazard**

**Tighten all terminal screws to the specified tightening torque.**

Loose electrical connections could result in death or serious injury by fire due to overheating of electrical connections.

**Do not use improper combustible materials.**

Failure to comply could result in death or serious injury by fire.

Do not install the drive to a combustible surface. Never place combustible materials on the drive.

**Do not use an improper voltage source.**

Failure to comply could result in death or serious injury by fire.

Verify that the rated voltage of the drive matches the voltage of the incoming power supply before applying power.

**When installing dynamic braking options, perform all wiring exactly as specified in the wiring diagrams provided.**

Failure to do so can result in fire. Improper wiring may damage braking components.

**Shut off the drive with a magnetic contactor (MC) when a fault occurs in any external equipment such as braking resistors.** Failure to comply may cause resistor overheating, fire, and injury to personnel.

#### **CAUTION**

**Do not carry the drive by the front cover or the terminal cover.**

Failure to comply may cause the main body of the drive to fall, resulting in minor or moderate injury.

#### **NOTICE**

**Observe proper electrostatic discharge procedures (ESD) when handling the drive and circuit boards.**

Failure to comply may result in ESD damage to the drive circuitry.

**Never connect or disconnect the motor from the drive while the drive is outputting voltage.**

Improper equipment sequencing could result in damage to the drive.

**Do not use unshielded cable for control wiring.**

Failure to comply may cause electrical interference resulting in poor system performance. Use shielded, twisted-pair wires and ground the shield to the ground terminal of the drive.

**Do not allow unqualified personnel to use the product.**

Failure to comply could result in damage to the drive or braking circuit.

Carefully review instruction manual TOBPC72060000 or TOBPC72060001 when connecting a dynamic braking option to the drive.

**Do not modify the drive circuitry.**

Failure to comply could result in damage to the drive and will void warranty.

Yaskawa is not responsible for any modification of the product made by the user. This product must not be modified.



**NOTICE**

**Check all the wiring to ensure that all connections are correct after installing the drive and connecting any other devices.**

Failure to comply could result in damage to the drive.

**Do not connect power supply lines to output terminals U/T1, V/T2, or W/T3.** Failure to comply will destroy the drive. Be sure to perform a final check of all sequence wiring and other connections before turning on the power and also check for short circuits on the control terminals, which may damage the drive.

**To get the full performance life out of the electrolytic capacitors and circuit relays, refrain from switching the drive power supply off and on more than once every 30 minutes.** Frequent use can damage the drive. Use the drive to stop and start the motor.

**NOTICE**

**Install a fuse and a GFCI in models 4A0930 and 4A1200.** Failure to comply may result in serious damage to the facilities if the drive is defective. *Refer to Wiring Fuses for Models 4A0930 and 4A1200 on page 22* for details.

### ◆ Standard Connection Diagram

**WARNING!** Sudden Movement Hazard. Do not close the wiring for the control circuit unless the multifunction input terminal parameters are properly set. Improper sequencing of run/stop circuitry could result in death or serious injury from moving equipment.

**WARNING!** Sudden Movement Hazard. Ensure start/stop and safety circuits are wired properly and in the correct state before energizing the drive. Failure to comply could result in death or serious injury from moving equipment. When programmed for 3-Wire control, a momentary closure on terminal S1 may cause the drive to start.

**WARNING!** Sudden Movement Hazard. When using a 3-Wire sequence, set the drive to 3-Wire sequence prior to wiring the control terminals and set parameter b1-17 to 0 so the drive will not accept a Run command at power up (default). If the drive is wired for a 3-Wire sequence but set up for a 2-Wire sequence (default), and parameter b1-17 is set to 1 so the drive accepts a Run command at power up, the motor will rotate in reverse direction at drive power up and may cause injury.

**WARNING!** Sudden Movement Hazard. Confirm the drive I/O signals and external sequence before executing the application preset function. Executing the application preset function or setting A1-06 ≠ 0 will change the drive I/O terminal functions and may cause unexpected equipment operation. Failure to comply may cause death or serious injury.

**NOTICE:** When using the automatic fault restart function with wiring designed to shut off the power supply upon drive fault, make sure the drive does not trigger a fault output during fault restart (L5-02 = 0, default). Failure to comply will prevent the automatic fault restart function from working properly.

**NOTICE:** Inadequate wiring could result in damage to the drive. Install adequate branch circuit short circuit protection per applicable codes. The drive is suitable for circuits capable of delivering not more than 100,000 RMS symmetrical amperes, 240 Vac maximum (200 V class), 480 Vac maximum (400 V class), 600 Vac maximum (600 V class).

**NOTICE:** When the input voltage is 440 V or higher or the wiring distance is greater than 100 meters, pay special attention to the motor insulation voltage or use a drive duty motor. Failure to comply could lead to motor insulation breakdown.

**NOTICE:** Do not connect AC control circuit ground to drive enclosure. Improper drive grounding can cause control circuit malfunction.

**NOTICE:** Route motor leads U/T1, V/T2, and W/T3 separate from all other leads to reduce possible interference related issues. Failure to comply may result in abnormal operation of drive and nearby equipment.

**NOTICE:** Correctly set Sink/Source jumper S3 for internal power supply. Failure to comply may result in damage to the drive.

**Note:** The minimum load for the relay outputs M1-M2, M3-M4, M5-M6, and MA-MB-MC is 10 mA.

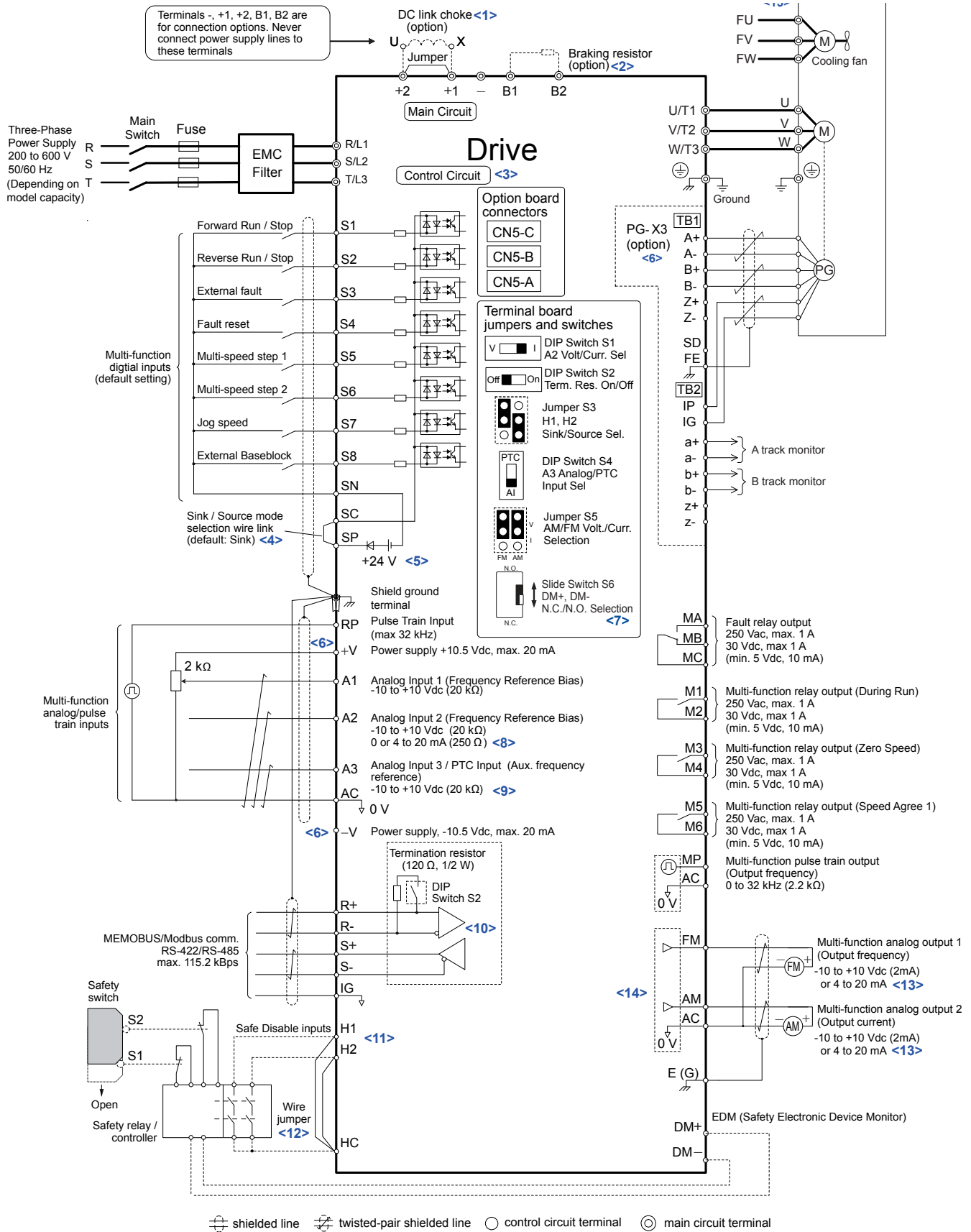

Figure i.9 Drive Standard Connection Diagram (example: model 2A0040)

<1> Remove the jumper when installing a DC link choke. Models 2A0110 to 2A0415 and 4A0058 to 4A1200 come with a built-in DC link choke.

### i.3 Electrical Installation Safety

---

- <2> Set L8-55 to 0 to disable the protection function of the built-in braking transistor of the drive when using an optional regenerative converter or dynamic braking option. Leaving L8-55 enabled may cause a braking resistor fault (rF). Additionally, disable Stall Prevention (L3-04 = 0) when using an optional regenerative converter, regenerative or braking units, or dynamic braking option. Leaving L3-04 enabled may prevent the drive from stopping within the specified deceleration time.
- <3> Supplying power to the control circuit separately from the main circuit requires 24 V power supply (option).
- <4> This figure illustrates an example of a sequence input to S1 through S8 using a non-powered relay or an NPN transistor. Install the wire link between terminals SC-SP for Sink mode, between SC-SN for Source mode, or leave the link out for external power supply. Never short terminals SP and SN, as it will damage the drive.
- <5> This voltage source supplies a maximum current of 150 mA when not using a digital input card DI-A3.
- <6> The maximum output current capacity for the +V and -V terminals on the control circuit is 20 mA. Never short terminals +V, -V, and AC, as it can cause erroneous operation or damage the drive.
- <7> Slide switch S6 selects N.C. or N.O. as the state of the DM+ and DM- terminals for EDM output. Slide switch S6 is available on terminal board ETC74030□.
- <8> Set DIP switch S1 to select between a voltage or current input signal to terminal A2. The default setting is for current input.
- <9> Set DIP switch S4 to select between analog or PTC input for terminal A3.
- <10> Set DIP switch S2 to the ON position to enable the termination resistor in the last drive in a MEMOBUS/Modbus network.
- <11> Use jumper S3 to select between Sink mode, Source mode, and external power supply for the Safe Disable inputs.  
**Note:** Terminals H1, H2, DM+, and DM- on 600 V class models are designed to the functionality, but are not certified to IEC/EN61800-5-1, ISO/EN13849 Cat. 3, IEC/EN61508 SIL2, Insulation coordination: class 1.
- <12> Disconnect the wire jumper between H1 - HC and H2 - HC when utilizing the Safe Disable input.  
**Note:** Terminals H1, H2, DM+, and DM- on 600 V class models are designed to the functionality, but are not certified to IEC/EN61800-5-1, ISO/EN13849 Cat. 3, IEC/EN61508 SIL2, Insulation coordination: class 1.
- <13> Monitor outputs work with devices such as analog frequency meters, ammeters, voltmeters, and wattmeters. They are not intended for use as a feedback-type signal.
- <14> Use jumper S5 to select between voltage or current output signals at terminals AM and FM. Set parameters H4-07 and H4-08 accordingly.
- <15> Self-cooling motors do not require the same wiring necessary for motors with cooling fans.

## ◆ Main Circuit Wiring

**WARNING!** *Electrical Shock Hazard. Do not connect the AC power line to the drive output terminals U/T1, V/T2, and W/T3. Failure to comply could result in death or serious injury by fire as a result of drive damage from line voltage application to output terminals.*

### NOTICE

Refer to the A1000 Technical Manual SIEPC71061641 on the CD-ROM packaged with the product for complete product instructions necessary for proper installation, set-up, troubleshooting and maintenance. CD part number TOECC71061615.

**NOTICE:** *Route motor leads U/T1, V/T2, and W/T3 separate from all other leads to reduce possible interference related issues. Failure to comply may result in abnormal operation of drive and nearby equipment.*

**NOTICE:** *Do not use the negative DC bus terminal “-” as a ground terminal. This terminal is at high DC voltage potential. Improper wiring connections could damage the drive.*

**NOTICE:** *Do not solder the ends of wire connections to the drive. Soldered wiring connections can loosen over time. Improper wiring practices could result in drive malfunction due to loose terminal connections.*

**NOTICE:** *Do not switch the drive input to start or stop the motor. Frequently switching the drive on and off shortens the life of the DC bus charge circuit and the DC bus capacitors, and can cause premature drive failures. For the full performance life, refrain from switching the drive on and off more than once every 30 minutes.*

**NOTICE:** *When connecting the motor to the drive output terminals U/T1, V/T2, and W/T3, the phase order for the drive and motor should match. Failure to comply with proper wiring practices may cause the motor to run in reverse if the phase order is backward.*

**NOTICE:** *Do not connect phase-advancing capacitors or LC/RC noise filters to the output circuits. Failure to comply could result in damage to the drive, phase-advancing capacitors, LC/RC noise filters or ground fault circuit interrupters.*

**Note:** Wire gauge recommendations based on drive continuous current ratings (ND) using 75 °C 600 Vac vinyl-sheathed wire assuming ambient temperature within 40 °C and wiring distance less than 100 m.

Yaskawa recommends using closed-loop crimp terminals on all drive models. UL/cUL approval requires the use of closed-loop crimp terminals when wiring the drive main circuit terminals on models 2A0110 to 2A0415 and 4A0058 to 4A1200. Use only the tools recommended by the terminal manufacturer for crimping.

## ◆ Main Circuit Terminal Functions

Table i.3 Main Circuit Terminal Functions

Terminal		Type				Function	Page
Class	Drive Model	2A0004 to 2A0081	2A0110 to 2A0138	2A0169 to 2A0415	-		
200 V Class					-		
400 V Class		4A0002 to 4A0044	4A0058, 4A0072	4A0088 to 4A0675	4A0930 to 4A1200		
600 V Class		5A0003 to 5A0032	5A0041 to 5A0052	5A0062 to 5A0242	-		
	R/L1	Main circuit power supply input				Connects line power to the drive	19
	S/L2						
	T/L3						
	R1-L11	Not available			Main circuit power supply input	Connects line power to the drive Remove the shorting bars connecting R/L1-R1/L11, S/L2-S1/L21, T/L3-T1/L31 when using 12-phase rectification.	19
	S1-L21						
	T1-L31						
	U/T1	Drive output				Connects to the motor	19
	V/T2						
	W/T3						
	B1	Braking resistor		Not available		Available for connecting a braking resistor or a braking resistor unit option	-
	B2						

### i.3 Electrical Installation Safety

Terminal		Type				Function	Page
200 V Class	Drive Model	2A0004 to 2A0081	2A0110 to 2A0138	2A0169 to 2A0415	–		
400 V Class		4A0002 to 4A0044	4A0058, 4A0072	4A0088 to 4A0675	4A0930 to 4A1200		
600 V Class		5A0003 to 5A0032	5A0041 to 5A0052	5A0062 to 5A0242	–		
+2	<ul style="list-style-type: none"> <li>DC link choke connection (+1, +2) (remove the shorting bar between +1 and +2)</li> <li>DC power supply input (+1, –)</li> </ul>	Not available					
+1		DC power supply input (+1, –)	<ul style="list-style-type: none"> <li>DC power supply input (+1, –)</li> <li>Braking unit connection (+3, –)</li> </ul>				
–							
+3	Not available						
⊕	For 200 V class: 100 Ω or less For 400 V class: 10 Ω or less For 600 V class: 10 Ω or less				Grounding terminal	34	

**Note:** Use terminals B1 and – when installing a CDBR-type braking unit on drives with built-in braking transistors (Models 2A0004 to 2A0138, 4A0002 to 4A0072, and 5A0003 to 5A0052).

#### Wiring Fuses for Models 4A0930 and 4A1200

**NOTICE:** If a fuse is blown or an Ground Fault Circuit Interrupter (GFCI) is tripped, check the wiring and the selection of peripheral devices to identify the cause. Contact Yaskawa before restarting the drive or the peripheral devices if the cause cannot be identified.

Install a fuse on the input side to protect drive wiring and prevent other secondary damage. Wire the fuse so that leakage current in the upper controller power supply will trigger the fuse and shut off the power supply.

Select the appropriate fuse from [Table i.4](#).

**Table i.4 Input Fuses for Models 4A0930 and 4A1200**

Voltage Class	Model	Selection			Input Fuse (Example)			
		Input Voltage	Current	Pre-arc I <sup>2</sup> t (A <sup>2</sup> s)	Model	Manufacturer	Rating	Pre-arc I <sup>2</sup> t (A <sup>2</sup> s)
Three-Phase 400 V Class	4A0930	480 V	1500 A	140000 to 3100000	CS5F-1200	Fuji Electric	AC500 V, 1200 A	276000
					FWH-1200A	Bussman	AC500 V, 1200 A	–
	4A1200	480 V	1500 A	320000 to 3100000	CS5F-1500	Fuji Electric	AC500 V, 1500 A	351000
					FWH-1600A	Bussman	AC500 V, 1600 A	–

### ◆ Main Circuit Wire Gauges and Tightening Torque

Use the tables in this section to select the appropriate wires and crimp terminals.

Gauges listed in the tables are for use in the United States.

- Note:**
- Wire gauge recommendations based on drive continuous current ratings (ND) using 75 °C 600 Vac vinyl-sheathed wire assuming ambient temperature within 40 °C and wiring distance less than 100 m.
  - Terminals +1, +2, +3, –, B1 and B2 are for connecting optional power devices. Use caution to connect only approved devices to the correct terminal(s).

- Consider the amount of voltage drop when selecting wire gauges. Increase the wire gauge when the voltage drop is greater than 2% of motor rated voltage. Ensure the wire gauge is suitable for the terminal block. Use the following formula to calculate the amount of voltage drop:

$$\text{Line drop voltage (V)} = \sqrt{3} \times \text{wire resistance } (\Omega/\text{km}) \times \text{wire length (m)} \times \text{current (A)} \times 10^{-3}$$

- Refer to instruction manual TOBP C720600 00 for braking transistor option or braking resistor option wire gauges.
- Use terminals +1 and – when connecting a regenerative converter or a regen unit.

**NOTICE:** Do not connect a braking resistor to terminals +1 or –. Failure to comply may cause damage to the drive circuitry.

- Use terminals B1 and – when installing a CDBR-type braking unit on drives with built-in braking transistors (models 2A0004 to 2A0138, 4A0002 to 4A0072, and 5A0003 to 5A0052).

**NOTICE:** Do not connect a braking resistor to terminals +1 or –. Failure to comply may cause damage to the drive circuitry.

- Refer to [UL Standards Compliance on page 46](#) for information on UL compliance.

Yaskawa recommends using closed-loop crimp terminals on all drive models. UL/cUL approval requires the use of closed-loop crimp terminals when wiring the drive main circuit terminals on models 2A0110 to 2A0415 and 4A0058 to 4A1200. Use only the tools recommended by the terminal manufacturer for crimping. *Refer to Closed-Loop Crimp Terminal Size on page 30* for closed-loop crimp terminal recommendations.

The wire gauges listed in the following tables are Yaskawa recommendations. Refer to local codes for proper wire gauge selections.

**■ Three-Phase 200 V Class**

**Table i.5 Wire Gauge and Torque Specifications (Three-Phase 200 V Class)**

Drive Model	Terminal	Recomm. Gauge AWG, kcmil	Wire Range AWG, kcmil	Screw Size	Tightening Torque N·m (lb.in.)
2A0004 2A0006 2A0008 2A0010	R/L1, S/L2, T/L3	14	14 to 10	M4	1.2 to 1.5 (10.6 to 13.3)
	U/T1, V/T2, W/T3	14	14 to 10		
	-, +1, +2	-	14 to 10		
	B1, B2	-	14 to 10		
	⊕	10 <I>	14 to 10		
2A0012	R/L1, S/L2, T/L3	12	14 to 10	M4	1.2 to 1.5 (10.6 to 13.3)
	U/T1, V/T2, W/T3	14	14 to 10		
	-, +1, +2	-	14 to 10		
	B1, B2	-	14 to 10		
	⊕	10 <I>	14 to 10		
2A0018	R/L1, S/L2, T/L3	10	12 to 10	M4	1.2 to 1.5 (10.6 to 13.3)
	U/T1, V/T2, W/T3	10	14 to 10		
	-, +1, +2	-	14 to 10		
	B1, B2	-	14 to 10		
	⊕	10 <I>	14 to 10		
2A0021	R/L1, S/L2, T/L3	10	12 to 10	M4	1.2 to 1.5 (10.6 to 13.3)
	U/T1, V/T2, W/T3	10	12 to 10		
	-, +1, +2	-	12 to 10		
	B1, B2	-	14 to 10		
	⊕	10 <I>	12 to 10		
2A0030	R/L1, S/L2, T/L3	8	10 to 6	M4	2.1 to 2.3 (18.6 to 20.4)
	U/T1, V/T2, W/T3	8	10 to 6		
	-, +1, +2	-	10 to 6		
	B1, B2	-	14 to 10		
	⊕	8 <I>	10 to 8	M5	2.0 to 2.5 (17.7 to 22.1)
2A0040	R/L1, S/L2, T/L3	6	8 to 6	M4	2.1 to 2.3 (18.6 to 20.4)
	U/T1, V/T2, W/T3	8	8 to 6		
	-, +1, +2	-	6		
	B1, B2	-	12 to 10		
	⊕	8 <I>	10 to 8	M5	2.0 to 2.5 (17.7 to 22.1)
2A0056	R/L1, S/L2, T/L3	4	6 to 4	M6	5.4 to 6.0 (47.8 to 53.1)
	U/T1, V/T2, W/T3	4	6 to 4		
	-, +1, +2	-	6 to 4		
	B1, B2	-	10 to 6	M5	2.7 to 3.0 (23.9 to 26.6)
	⊕	6	8 to 6	M6	5.4 to 6.0 (47.8 to 53.1)

### i.3 Electrical Installation Safety

Drive Model	Terminal	Recomm. Gauge AWG, kcmil	Wire Range AWG, kcmil	Screw Size	Tightening Torque N·m (lb.in.)
2A0069	R/L1, S/L2, T/L3	3	4 to 3	M8	9.9 to 11.0 (87.6 to 97.4)
	U/T1, V/T2, W/T3	3	4 to 3		
	-, +1, +2	-	4 to 3		
	B1, B2	-	8 to 6	M5	2.7 to 3.0 (23.9 to 26.6)
	⊕	6	6 to 4	M6	5.4 to 6.0 (47.8 to 53.1)
2A0081	R/L1, S/L2, T/L3	2	3 to 2	M8	9.9 to 11.0 (87.6 to 97.4)
	U/T1, V/T2, W/T3	2	3 to 2		
	-, +1, +2	-	3 to 2		
	B1, B2	-	6	M5	2.7 to 3.0 (23.9 to 26.6)
	⊕	6	6 to 4	M6	5.4 to 6.0 (47.8 to 53.1)
2A0110	R/L1, S/L2, T/L3	1/0	3 to 1/0	M8	9 to 11 (79.7 to 97.4)
	U/T1, V/T2, W/T3	1/0	3 to 1/0		
	-, +1	-	2 to 1/0		
	B1, B2	-	6 to 1/0		
	⊕	6	6 to 4		
2A0138	R/L1, S/L2, T/L3	2/0	1 to 2/0	M10	18 to 23 (159 to 204)
	U/T1, V/T2, W/T3	2/0	1 to 2/0		
	-, +1	-	1/0 to 3/0		
	B1, B2	-	4 to 2/0		
	⊕	4	4	M8	9 to 11 (79.7 to 97.4)
2A0169	R/L1, S/L2, T/L3	4/0	2/0 to 4/0	M10	18 to 23 (159 to 204)
	U/T1, V/T2, W/T3	4/0	3/0 to 4/0		
	-, +1	-	1 to 4/0		
	+3	-	1/0 to 4/0		
	⊕	4	4 to 2		
2A0211	R/L1, S/L2, T/L3	1/0 × 2P	1/0 to 2/0	M10	18 to 23 (159 to 204)
	U/T1, V/T2, W/T3	1/0 × 2P	1/0 to 2/0		
	-, +1	-	1 to 4/0		
	+3	-	1/0 to 4/0		
	⊕	4	4 to 1/0		
2A0250	R/L1, S/L2, T/L3	3/0 × 2P	3/0 to 300	M12	32 to 40 (283 to 354)
	U/T1, V/T2, W/T3	3/0 × 2P	3/0 to 300		
	-, +1	-	3/0 to 300		
	+3	-	2 to 300	M10	18 to 23 (159 to 204)
	⊕	3	3 to 300	M12	32 to 40 (283 to 354)
2A0312	R/L1, S/L2, T/L3	4/0 × 2P	3/0 to 300	M12	32 to 40 (283 to 354)
	U/T1, V/T2, W/T3	3/0 × 2P	3/0 to 300		
	-, +1	-	3/0 to 300		
	+3	-	3/0 to 300	M10	18 to 23 (159 to 204)
	⊕	2	2 to 300	M12	32 to 40 (283 to 354)



Drive Model	Terminal	Recomm. Gauge AWG, kcmil	Wire Range AWG, kcmil	Screw Size	Tightening Torque N·m (lb.in.)
2A0360	R/L1, S/L2, T/L3	250 × 2P	4/0 to 600	M12	32 to 40 (283 to 354)
	U/T1, V/T2, W/T3	4/0 × 2P	4/0 to 600		
	-, +1	-	250 to 600		
	+3	-	3/0 to 600	M10	18 to 23 (159 to 204)
	⊕	1	1 to 350	M12	32 to 40 (283 to 354)
2A0415	R/L1, S/L2, T/L3	350 × 2P	250 to 600	M12	32 to 40 (283 to 354)
	U/T1, V/T2, W/T3	300 × 2P	300 to 600		
	-, +1	-	300 to 600		
	+3	-	3/0 to 600	M10	18 to 23 (159 to 204)
	⊕	1	1 to 350	M12	32 to 40 (283 to 354)

<1> Install an ELCB when using this wire gauge in accordance with IEC/EN61800-5-1. Refer to the Technical Manual section on EMC Filter Installation for details.

<2> Install an ELCB, or use 10 mm<sup>2</sup> (AWG 8) copper wire when using this wire gauge in accordance with IEC/EN61800-5-1.

**Note:** When connecting peripheral devices or options to terminals -, +1, +3, B1, and B2, refer to the instruction manual for each device. For more information, contact Yaskawa or your nearest sales representative.

### ■ Three-Phase 400 V Class

Table i.6 Wire Gauge and Torque Specifications (Three-Phase 400 V Class)

Drive Model	Terminal	Recomm. Gauge AWG, kcmil	Wire Range AWG, kcmil	Screw Size	Tightening Torque N·m (lb.in.)
4A0002 4A0004	R/L1, S/L2, T/L3	14	14 to 10	M4	1.2 to 1.5 (10.6 to 13.3)
	U/T1, V/T2, W/T3	14	14 to 10		
	-, +1, +2	-	14 to 10		
	B1, B2	-	14 to 10		
	⊕	12 <?>	14 to 12		
4A0005 4A0007 4A0009	R/L1, S/L2, T/L3	14	14 to 10	M4	1.2 to 1.5 (10.6 to 13.3)
	U/T1, V/T2, W/T3	14	14 to 10		
	-, +1, +2	-	14 to 10		
	B1, B2	-	14 to 10		
	⊕	10 <?>	14 to 10		
4A0011	R/L1, S/L2, T/L3	12	14 to 10	M4	1.2 to 1.5 (10.6 to 13.3)
	U/T1, V/T2, W/T3	14	14 to 10		
	-, +1, +2	-	14 to 10		
	B1, B2	-	14 to 10		
	⊕	10 <?>	14 to 10		
4A0018	R/L1, S/L2, T/L3	10	12 to 6	M4	2.1 to 2.3 (18.6 to 20.4)
	U/T1, V/T2, W/T3	10	12 to 6		
	-, +1, +2	-	12 to 6		
	B1, B2	-	12 to 10		
	⊕	10 <?>	14 to 10	M5	2.0 to 2.5 (17.7 to 22.1)
4A0023	R/L1, S/L2, T/L3	10	10 to 6	M4	2.1 to 2.3 (18.6 to 20.4)
	U/T1, V/T2, W/T3	10	10 to 6		
	-, +1, +2	-	12 to 6		
	B1, B2	-	12 to 10		
	⊕	10 <?>	12 to 10	M5	2.0 to 2.5 (17.7 to 22.1)

### i.3 Electrical Installation Safety

Drive Model	Terminal	Recomm. Gauge AWG, kcmil	Wire Range AWG, kcmil	Screw Size	Tightening Torque N·m (lb.in.)
4A0031	R/L1, S/L2, T/L3	8	8 to 6	M5	3.6 to 4.0 (31.8 to 35.4)
	U/T1, V/T2, W/T3	8	10 to 6		
	-, +1, +2	-	10 to 6		
	B1, B2	-	10 to 8	M6	2.7 to 3.0 (23.9 to 26.6)
	⊕	8 <->	10 to 8		
4A0038	R/L1, S/L2, T/L3	6	8 to 6	M5	3.6 to 4.0 (31.8 to 35.4)
	U/T1, V/T2, W/T3	8	8 to 6		
	-, +1, +2	-	6		
	B1, B2	-	10 to 8	M6	2.7 to 3.0 (23.9 to 26.6)
	⊕	6	10 to 6		
4A0044	R/L1, S/L2, T/L3	6	6 to 4	M6	5.4 to 6.0 (47.8 to 53.1)
	U/T1, V/T2, W/T3	6	6 to 4		
	-, +1, +2	-	6 to 4		
	B1, B2	-	10 to 8	M5	2.7 to 3.0 (23.9 to 26.6)
	⊕	6	8 to 6	M6	5.4 to 6.0 (47.8 to 53.1)
4A0058	R/L1, S/L2, T/L3	4	6 to 4	M8	9 to 11 (79.7 to 97.4)
	U/T1, V/T2, W/T3	4	6 to 4		
	-, +1	-	6 to 1		
	B1, B2	-	8 to 4		
	⊕	6	8 to 6		
4A0072	R/L1, S/L2, T/L3	3	4 to 3	M8	9 to 11 (79.7 to 97.4)
	U/T1, V/T2, W/T3	3	4 to 3		
	-, +1	-	4 to 1		
	B1, B2	-	6 to 3		
	⊕	6	6		
4A0088	R/L1, S/L2, T/L3	2	3 to 1/0	M8	9 to 11 (79.7 to 97.4)
	U/T1, V/T2, W/T3	2	3 to 1/0		
	-, +1	-	3 to 1/0		
	+3	-	6 to 1/0		
	⊕	4	6 to 4		
4A0103	R/L1, S/L2, T/L3	1/0	2 to 1/0	M8	9 to 11 (79.7 to 97.4)
	U/T1, V/T2, W/T3	1	2 to 1/0		
	-, +1	-	3 to 1/0		
	+3	-	4 to 1/0		
	⊕	4	6 to 4		
4A0139	R/L1, S/L2, T/L3	3/0	1/0 to 4/0	M10	18 to 23 (159 to 204)
	U/T1, V/T2, W/T3	2/0	1/0 to 4/0		
	-, +1	-	1/0 to 4/0		
	+3	-	3 to 4/0		
	⊕	4	4		
4A0165	R/L1, S/L2, T/L3	4/0	3/0 to 4/0	M10	18 to 23 (159 to 204)
	U/T1, V/T2, W/T3	4/0	3/0 to 4/0		
	-, +1	-	1 to 4/0		
	+3	-	1/0 to 4/0		
	⊕	4	4 to 2		

Drive Model	Terminal	Recomm. Gauge AWG, kcmil	Wire Range AWG, kcmil	Screw Size	Tightening Torque N·m (lb.in.)
4A0208	R/L1, S/L2, T/L3	300	2 to 300	M10	18 to 23 (159 to 204)
	U/T1, V/T2, W/T3	300	2 to 300		
	-,+1	-	1 to 250		
	+3	-	3 to 3/0		
	⊕	4	4 to 300		
4A0250	R/L1, S/L2, T/L3	400	1 to 600	M10	18 to 23 (159 to 204)
	U/T1, V/T2, W/T3	400	1/0 to 600		
	-,+1	-	3/0 to 600		
	+3	-	1 to 325		
	⊕	2	2 to 350		
4A0296	R/L1, S/L2, T/L3	500	2/0 to 600	M12	32 to 40 (283 to 354)
	U/T1, V/T2, W/T3	500	2/0 to 600		
	-,+1	-	3/0 to 600	M10	18 to 23 (159 to 204)
	+3	-	1 to 325		
	⊕	2	2 to 350		
4A0362	R/L1, S/L2, T/L3	4/0 × 2P	3/0 to 600	M12	32 to 40 (283 to 354)
	U/T1, V/T2, W/T3	4/0 × 2P	3/0 to 600		
	-,+1	-	4/0 to 600	M10	18 to 23 (159 to 204)
	+3	-	3/0 to 600		
	⊕	1	1 to 350		
4A0414	R/L1, S/L2, T/L3	300 × 2P	4/0 to 300	M12	32 to 40 (283 to 354)
	U/T1, V/T2, W/T3	300 × 2P	4/0 to 300		
	-,+1	-	3/0 to 300		
	+3	-	3/0 to 300		
	⊕	1	1 to 3/0		
4A0515	R/L1, S/L2, T/L3	3/0 × 4P	3/0 to 300	M12	32 to 40 (283 to 354)
	U/T1, V/T2, W/T3	4/0 × 4P	3/0 to 300		
	-,+1	-	1/0 to 300		
	+3	-	1/0 to 300		
	⊕	1/0	1/0 to 300		
4A0675	R/L1, S/L2, T/L3	300 × 4P	4/0 to 300	M12	32 to 40 (283 to 354)
	U/T1, V/T2, W/T3	300 × 4P	4/0 to 300		
	-,+1	-	1/0 to 300		
	+3	-	1/0 to 300		
	⊕	2/0	2/0 to 300		
4A0930	R/L1, S/L2, T/L3, R1/L11, S1/L21, T1/L31	4/0 × 4P×2	3/0 to 300	M12	32 to 40 (283 to 354)
	U/T1, V/T2, W/T3	4/0 × 4P×2	3/0 to 300		
	-,+1	-	4/0 to 300		
	+3	-	4/0 to 300		
	⊕	3/0	3/0 to 250		
4A1200	R/L1, S/L2, T/L3, R1/L11, S1/L21, T1/L31	300 × 4P×2	4/0 to 300	M12	32 to 40 (283 to 354)
	U/T1, V/T2, W/T3	300 × 4P×2	4/0 to 300		
	-,+1	-	250 to 300		
	+3	-	4/0 to 300		
	⊕	4/0	4/0 to 250		

<1> Install an ELCB when using this wire gauge in accordance with IEC/EN61800-5-1.

### i.3 Electrical Installation Safety

<2> Install an ELCB or use 10 mm<sup>2</sup> (AWG 8) copper wire when using this wire gauge in accordance with IEC/EN61800-5-1.

**Note:** When connecting peripheral devices or options to terminals, -, +1, +3, B1, and B2, refer to the instruction manual for each device. For more information, contact Yaskawa or your nearest sales representative.

#### ■ Three-Phase 600 V Class

Table i.7 Wire Gauge and Torque Specifications (Three-Phase 600 V Class)

Drive Model	Terminal	Recomm. Gauge AWG, kcmil	Wire Range AWG, kcmil	Screw Size	Tightening Torque N·m (lb.in.)
5A0003 5A0004 5A0006	R/L1, S/L2, T/L3	14	14 to 10	M4	1.2 to 1.5 (10.6 to 13.3)
	U/T1, V/T2, W/T3	14	14 to 10		
	-, +1, +2	-	14 to 10		
	B1, B2	-	14 to 10		
	⊕	10	14 to 10		
5A0009	R/L1, S/L2, T/L3	14	14 to 10	M4	1.2 to 1.5 (10.6 to 13.3)
	U/T1, V/T2, W/T3	14	14 to 10		
	-, +1, +2	-	14 to 10		
	B1, B2	-	14 to 10		
	⊕	10	12 to 10		
5A0011	R/L1, S/L2, T/L3	10	14 to 6	M4	2.1 to 2.3 (18.6 to 20.4)
	U/T1, V/T2, W/T3	14	14 to 6		
	-, +1, +2	-	14 to 6		
	B1, B2	-	14 to 10		
	⊕	8	12 to 8	M5	2.0 to 2.5 (17.7 to 22.1)
5A0017	R/L1, S/L2, T/L3	10	10 to 6	M5	3.6 to 4.0 (31.8 to 35.4)
	U/T1, V/T2, W/T3	10	10 to 6		
	-, +1, +2	-	10 to 6		
	B1, B2	-	10 to 8		
	⊕	8	12 to 8	M6	5.4 to 6.0 (47.8 to 53.1)
5A0022	R/L1, S/L2, T/L3	8	10 to 6	M5	3.6 to 4.0 (31.8 to 35.4)
	U/T1, V/T2, W/T3	10	10 to 6		
	-, +1, +2	-	10 to 6		
	B1, B2	-	10 to 8		
	⊕	8	10 to 6	M6	5.4 to 6.0 (47.8 to 53.1)
5A0027 5A0032	R/L1, S/L2, T/L3	6	6 to 4	M6	5.4 to 6.0 (47.8 to 53.1)
	U/T1, V/T2, W/T3	6	6 to 4		
	-, +1, +2	-	6 to 4		
	B1, B2	-	10 to 8	M5	2.7 to 3.0 (23.9 to 26.6)
	⊕	6	10 to 6	M6	5.4 to 6.0 (47.8 to 53.1)
5A0041	R/L1, S/L2, T/L3	6	10 to 3	M8	9.0 to 11 (79.7 to 97.4)
	U/T1, V/T2, W/T3	6	10 to 3		
	-, +1	-	6 to 1		
	B1, B2	-	12 to 3		
	⊕	6	6		
5A0052	R/L1, S/L2, T/L3	4	10 to 3	M8	9.0 to 11 (79.7 to 97.4)
	U/T1, V/T2, W/T3	6	10 to 3		
	-, +1	-	6 to 1		
	B1, B2	-	8 to 3		
	⊕	6	6		

Drive Model	Terminal	Recomm. Gauge AWG, kcmil	Wire Range AWG, kcmil	Screw Size	Tightening Torque N·m (lb.in.)
5A0062	R/L1, S/L2, T/L3	4	10 to 4/0	M10	18 to 23 (159 to 204)
	U/T1, V/T2, W/T3	4	10 to 4/0		
	-, +1	-	4 to 4/0		
	+3	-	6 to 4/0		
	⊕	4	4		
5A0077	R/L1, S/L2, T/L3	3	10 to 4/0	M10	18 to 23 (159 to 204)
	U/T1, V/T2, W/T3	3	10 to 4/0		
	-, +1	-	3 to 4/0		
	+3	-	6 to 4/0		
	⊕	4	4		
5A0099	R/L1, S/L2, T/L3	1/0	10 to 4/0	M10	18 to 23 (159 to 204)
	U/T1, V/T2, W/T3	1	10 to 4/0		
	-, +1	-	2 to 4/0		
	+3	-	4 to 4/0		
	⊕	4	4		
5A0125	R/L1, S/L2, T/L3	2/0	1 to 300	M10	18 to 23 (159 to 204)
	U/T1, V/T2, W/T3	2/0	1 to 300		
	-, +1	-	2/0 to 3/0		
	+3	-	1 to 1/0		
	⊕	3	4 to 300		
5A0145	R/L1, S/L2, T/L3	3/0	2/0 to 300	M10	18 to 23 (159 to 204)
	U/T1, V/T2, W/T3	3/0	2/0 to 300		
	-, +1	-	3/0 to 4/0		
	+3	-	1/0 to 2/0		
	⊕	3	4 to 300		
5A0192	R/L1, S/L2, T/L3	300	2/0 to 600	M12	32 to 40 (283 to 354)
	U/T1, V/T2, W/T3	250	2/0 to 600	M10	18 to 23 (159 to 204)
	-, +1	-	2/0 to 400		
	+3	-	2/0 to 250	M12	32 to 40 (283 to 354)
	⊕	1	1 to 350		
5A0242	R/L1, S/L2, T/L3	400	2/0 to 600	M12	32 to 40 (283 to 354)
	U/T1, V/T2, W/T3	350	2/0 to 600		
	-, +1	-	2/0 to 500	M10	18 to 23 (159 to 204)
	+3	-	250 to 300		
	⊕	1	1 to 350	M12	32 to 40 (283 to 354)

**Note:** When connecting peripheral devices or options to terminals -, +1, +3, B1, and B2, refer to the instruction manual for each device. For more information, contact Yaskawa or your nearest sales representative.

**Closed-Loop Crimp Terminal Recommendations**

Yaskawa recommends UL listed crimp terminals made by JST and Tokyo DIP (or equivalent) for the insulation cap. **Table i.8** matches the wire gauges and terminal screw sizes with Yaskawa-recommended crimp terminals, tools, and insulation caps. Refer to the appropriate Wire Gauge and Torque Specifications table for the wire gauge and screw size for your drive model. Place orders with a Yaskawa representative or the Yaskawa sales department.

The closed-loop crimp terminal sizes and values listed in **Table i.8** are Yaskawa recommendations.

Wire gauge values shown in **bold italic** are the recommended values. Refer to local codes for proper selections.

### i.3 Electrical Installation Safety

Table i.8 Closed-Loop Crimp Terminal Size

Drive Model	Wire Gauge (AWG, kcmil)		Screw Size	Crimp Terminal Model Number	Tool		Insulation Cap Model No.	Code <1>
	R/L1, S/L2, T/L3	U/T1, V/T2, W/T3			Machine No.	Die Jaw		
<b>200 V Class</b>								
2A0004 2A0006 2A0008 2A0010	14		M4	R2-4	YA-4	AD-900	TP-003	100-054-028
	12			R5.5-4			TP-005	100-054-029
	14	14		R2-4			TP-003	100-054-028
	12	12		R5.5-4			TP-005	100-054-029
2A0012	10		M4	R2-4	YA-4	AD-900	TP-003	100-054-028
	14	14		R5.5-4			TP-005	100-054-029
	12	12		R2-4			TP-003	100-054-028
2A0018	10		M4	R2-4	YA-4	AD-900	TP-003	100-054-028
	14	14		R5.5-4			TP-005	100-054-029
	12	12		R2-4			TP-003	100-054-028
2A0021	10		M4	R5.5-4	YA-4	AD-900	TP-005	100-054-029
	12			R5.5-4			TP-005	100-054-029
2A0030	10		M4	R5.5-4	YA-4	AD-900	TP-005	100-054-029
	8			8-4		AD-901	TP-008	100-054-031
	6			14-NK4		AD-902	TP-014	100-054-033
2A0040	8	8	M4	8-4	YA-4	AD-901	TP-008	100-054-031
	6	6		14-NK4		AD-902	TP-014	100-054-033
2A0056	6		M6	R14-6	YA-5	AD-952	TP-014	100-051-261
	4			R22-6		AD-953	TP-022	100-051-262
2A0069	4		M8	R22-8	YA-5	AD-953	TP-022	100-051-263
	3			R38-8		AD-954	TP-038	100-051-264
2A0081	3		M8	R38-8	YA-5	AD-954	TP-038	100-051-264
	2			R38-8		AD-954	TP-038	100-051-264
2A0110	3		M8	R38-8	YA-5	AD-954	TP-038	100-051-264
	2							
	1							
	1/0							
2A0138	1		M10	R38-10	YF-1 YET-300-1	TD-321, TD-311	TP-060	100-061-114
	1/0			R60-10		TD-323, TD-312	TP-080	100-054-036
	2/0			70-10		TD-323, TD-312	TP-080	100-054-036
2A0169	2/0	–	M10	70-10	YF-1 YET-300-1	TD-323, TD-312	TP-080	100-054-036
	3/0			80-10		TD-324, TD-312	TP-100	100-051-267
	4/0			R100-10		TP-100	100-051-269	
2A0211	1/0 × 2P		M10	R60-10	YF-1 YET-300-1	TD-321, TD-311	TP-060	100-051-266
	2/0 × 2P			70-10		TD-323, TD-312	TP-080	100-054-036
2A0250	3/0 × 2P		M12	80-L12	YF-1 YET-300-1	TD-323, TD-312	TP-080	100-051-558
	4/0 × 2P			100-L12		TD-324, TD-312	TP-100	100-051-560
	–	250 × 2P		150-L12		TD-325, TD-313	TP-150	100-051-562
	250	–		R150-12			TP-150	100-051-273
	300							
2A0312	3/0 × 2P	3/0 × 2P	M12	80-L12	YF-1 YET-300-1	TD-323, TD-312	TP-080	100-051-558
	4/0 × 2P			100-L12		TD-324, TD-312	TP-100	100-051-560
	250 × 2P			150-L12		TD-325, TD-313	TP-150	100-051-562
	300 × 2P							

Drive Model	Wire Gauge (AWG, kcmil)		Screw Size	Crimp Terminal Model Number	Tool		Insulation Cap Model No.	Code <1>	
	R/L1, S/L2, T/L3	U/T1, V/T2, W/T3			Machine No.	Die Jaw			
2A0360	4/0 × 2P	4/0 × 2P	M12	100-L12	YF-1 YET-300-1	TD-324, TD-312	TP-100	100-051-560	
	250 × 2P	250 × 2P		150-L12		TD-325, TD-313	TP-150	100-051-562	
	300 × 2P			180-L12		TD-327, TD-314	TP-200	100-066-688	
	350 × 2P			200-L12				100-051-564	
	400 × 2P			325-12		TD-328, TD-315	TP-325	100-051-277	
	500 × 2P								
2A0415	250 × 2P	–	M12	150-L12	YF-1 YET-300-1	TD-325, TD-313	TP-150	100-051-562	
	300 × 2P	300 × 2P		180-L12		TD-327, TD-314	TP-200	100-066-688	
	350 × 2P	350 × 2P		200-L12				100-051-564	
	400 × 2P			325-12		TD-328, TD-315	TP-325	100-051-277	
	500 × 2P								
	600 × 2P								
<b>400 V Class</b>									
4A0002 4A0004 4A0005 4A0007 4A0009	14		M4	R2-4	YA-4	AD-900	TP-003	100-054-028	
12		R5.5-4		AD-900			TP-005	100-054-029	
10									
4A0011	14	14	M4	R2-4	YA-4	AD-900	TP-003	100-054-028	
	12	12		R5.5-4			AD-900	TP-005	100-054-029
	10								
4A0018	12		M4	R5.5-4	YA-4	AD-900	TP-005	100-054-029	
	10						AD-901	TP-008	100-054-031
	8			14-NK4		AD-902		TP-014	100-054-033
	6								
4A0023	10		M4	R5.5-4	YA-4	AD-900	TP-005	100-054-029	
	8			8-4			AD-901	TP-008	100-054-031
	6							14-NK4	AD-902
10									
4A0031	–	10	M5	R5.5-5	YA-4	AD-900	TP-005	100-054-030	
	8			R8-5			AD-901	TP-008	100-054-032
	6							R14-5	AD-902
8									
4A0038	8	8	M5	R8-5	YA-4	AD-901	TP-008	100-054-032	
	6	6		R14-5			AD-902	TP-014	100-054-034
4A0044	6		M6	R14-6	YA-5	AD-952	TP-014	100-051-261	
	4			R22-6			AD-953	TP-022	100-051-262
4A0058	6		M8	R14-8	YA-5	AD-952	TP-014	100-054-035	
	4			R22-8			AD-953	TP-022	100-051-263
4A0072	4		M8	R22-8	YA-5	AD-953	TP-022	100-051-263	
	3			R38-8			AD-954	TP-038	100-051-264
4A0088	3		M8	R38-8	YA-5	AD-954	TP-038	100-051-264	
	2								
	1			R60-8		AD-955	TP-060	100-051-265	
	1/0								
4A0103	2		M8	R38-8	YA-5	AD-954	TP-038	100-051-264	
	1	1							
	1/0	1/0							

### i.3 Electrical Installation Safety

Drive Model	Wire Gauge (AWG, kcmil)		Screw Size	Crimp Terminal Model Number	Tool		Insulation Cap Model No.	Code <1>
	R/L1, S/L2, T/L3	U/T1, V/T2, W/T3			Machine No.	Die Jaw		
4A0139	1/0		M10	R60-10	YF-1 YET-300-1	TD-321, TD-311	TP-060	100-051-266
	2/0	2/0		70-10		TD-323, TD-312	TP-080	100-054-036
	3/0	3/0		80-10				100-051-267
	4/0			R100-10		TD-324, TD-312	TP-100	100-051-269
4A0165	3/0		M10	80-10	YF-1 YET-300-1	TD-323, TD-312	TP-080	100-051-267
	4/0			R100-10		TD-324, TD-312	TP-100	100-051-269
4A0208	2 × 2P		M10	38-L10	YF-1 YET-150-1	TD-224, TD-212	TP-038	100-051-556
	1 × 2P			80-L10		TD-227, TD-214	TP-080	100-051-557
	3/0 × 2P			R100-10		TD-228, TD-214	TP-100	100-051-269
	4/0			R150-10		TD-229, TD-215	TP-150	100-051-272
	250							
	300							
4A0250	1 × 2P	–	M10	38-L10	YF-1 YET-150-1	TD-224, TD-212	TP-038	100-051-556
	3/0 × 2P			80-L10		TD-227, TD-214	TP-080	100-051-557
	4/0 × 2P			100-L10		TD-228, TD-214	TP-100	100-051-559
	250 × 2P			150-L10		TD-229, TD-215	TP-150	100-051-561
	300			R150-10		TP-150	100-051-272	
	350			180-10	YF-1 YET-300-1	TD-327, TD-314	TP-200	100-066-687
	400			200-10		TD-328, TD-315	TP-325	100-051-565
	500							
	600							
	4A0296	3/0 × 2P		M12	80-L12	YF-1 YET-300-1	TD-323, TD-312	TP-080
4/0 × 2P		100-L12	TD-324, TD-312		TP-100		100-051-560	
250 × 2P		150-L12	TD-325, TD-313		TP-150		100-051-562	
300 × 2P		180-L12	TD-327, TD-314		TP-200		100-066-688	
–		350 × 2P					180-12	100-066-689
350		–					R200-12	100-051-275
400								
500								
600			325-12	TD-328, TD-315	TP-325	100-051-277		
4A0362	3/0 × 2P		M12	80-L12	YF-1 YET-300-1	TD-323, TD-312	TP-080	100-051-558
	4/0 × 2P			100-L12		TD-324, TD-312	TP-100	100-051-560
	250 × 2P			150-L12		TD-325, TD-313	TP-150	100-051-562
	300 × 2P			180-L12		TD-327, TD-314	TP-200	100-066-688
	350 × 2P			200-L12				100-051-564
	400 × 2P							
	500					325-12	TD-328, TD-315	TP-325
600								
4A0414	4/0 × 2P		M12	100-L12	YF-1 YET-300-1	TD-324, TD-312	TP-100	100-051-560
	250 × 2P			150-L12		TD-325, TD-313	TP-150	100-051-562
	300 × 2P							



Drive Model	Wire Gauge (AWG, kcmil)		Screw Size	Crimp Terminal Model Number	Tool		Insulation Cap Model No.	Code <1>
	R/L1, S/L2, T/L3	U/T1, V/T2, W/T3			Machine No.	Die Jaw		
4A0515	3/0 × 4P	3/0 × 4P	M12	80-L12	YF-1 YET-300-1	TD-323, TD-312	TP-080	100-051-558
	4/0 × 4P	4/0 × 4P		100-L12		TD-324, TD-312	TP-100	100-051-560
	250 × 4P			150-L12		TD-325, TD-313	TP-150	100-051-562
	300 × 2P							
4A0675	4/0 × 4P		M12	100-L12	YF-1 YET-300-1	TD-324, TD-312	TP-100	100-051-560
	250 × 4P			150-L12		TD-325, TD-313	TP-150	100-051-562
	300 × 4P							
4A0930	3/0 × 8P		M12	80-L12	YF-1 YET-300-1	TD-323, TD-312	TP-080	100-051-558
	4/0 × 8P			100-L12		TD-324, TD-312	TP-100	100-051-560
	250 × 8P			150-L12		TD-325, TD-313	TP-150	100-051-562
	300 × 8P							
4A1200	4/0 × 8P		M12	100-L12	YF-1 YET-300-1	TD-324, TD-312	TP-100	100-051-560
	250 × 8P			150-L12		TD-325, TD-313	TP-150	100-051-562
	300 × 8P							

<1> Codes refer to a set of three crimp terminals and three insulation caps. Prepare input and output wiring using two sets for each connection.  
 Example 1: Models with 300 kcmil for both input and output require one set for input terminals and one set for output terminals, so the user should order two sets of [100-051-272].  
 Example 2: Models with 4/0 AWG × 2P for both input and output require two sets for input terminals and two sets for output terminals, so the user should order four sets of [100-051-560].

**Note:** Use crimp insulated terminals or insulated shrink tubing for wiring connections. Wires should have a continuous maximum allowable temperature of 75 °C 600 Vac UL-approved vinyl-sheathed insulation.

## i.3 Electrical Installation Safety

### ■ Ground Wiring

Follow the precautions below when wiring the ground for one drive or a series of drives.

**WARNING! Electrical Shock Hazard.** Make sure the protective earthing conductor complies with technical standards and local safety regulations. Because the leakage current exceeds 3.5 mA in models 4A0414 and larger, IEC/EN 61800-5-1 states that either the power supply must be automatically disconnected in case of discontinuity of the protective earthing conductor or a protective earthing conductor with a cross-section of at least 10 mm<sup>2</sup> (Cu) or 16 mm<sup>2</sup> (Al) must be used. Failure to comply may result in death or serious injury.

**WARNING! Electrical Shock Hazard.** Always use a ground wire that complies with technical standards on electrical equipment and minimize the length of the ground wire. Improper equipment grounding may cause dangerous electrical potentials on equipment chassis, which could result in death or serious injury.

**WARNING! Electrical Shock Hazard.** Be sure to ground the drive ground terminal (200 V class: ground to 100 Ω or less; 400 V class: ground to 10 Ω or less; 600 V class: ground to 10 Ω or less). Improper equipment grounding could result in death or serious injury by contacting ungrounded electrical equipment.

**NOTICE:** Do not share the ground wire with other devices such as welding machines or large-current electrical equipment. Improper equipment grounding could result in drive or equipment malfunction due to electrical interference.

**NOTICE:** When using more than one drive, ground multiple drives according to instructions. Improper equipment grounding could result in abnormal operation of drive or equipment.

Refer to [Figure i.10](#) when using multiple drives. Do not loop the ground wire.

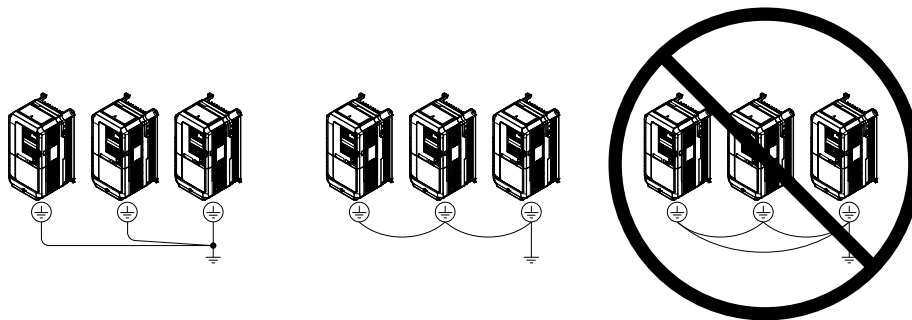

Figure i.10 Multiple Drive Wiring

### ◆ Control Circuit Connections

Drive parameters determine which functions apply to the multi-function digital inputs (S1 to S8), multi-function digital outputs (M1 to M6), multi-function analog inputs (A1 to A3), and multi-function analog monitor output (FM, AM). The default setting is listed next to each terminal in **Figure i.9** on page 19.

**WARNING!** Sudden Movement Hazard. Always check the operation and wiring of control circuits after being wired. Operating a drive with untested control circuits could result in death or serious injury.

**WARNING!** Sudden Movement Hazard. Confirm the drive I/O signals and external sequence before starting test run. Setting parameter A1-06 may change the I/O terminal function automatically from the factory setting. Failure to comply may result in death or serious injury.

### ◆ Terminal Configuration

The control circuit terminals are arranged as shown in **Figure i.11**.

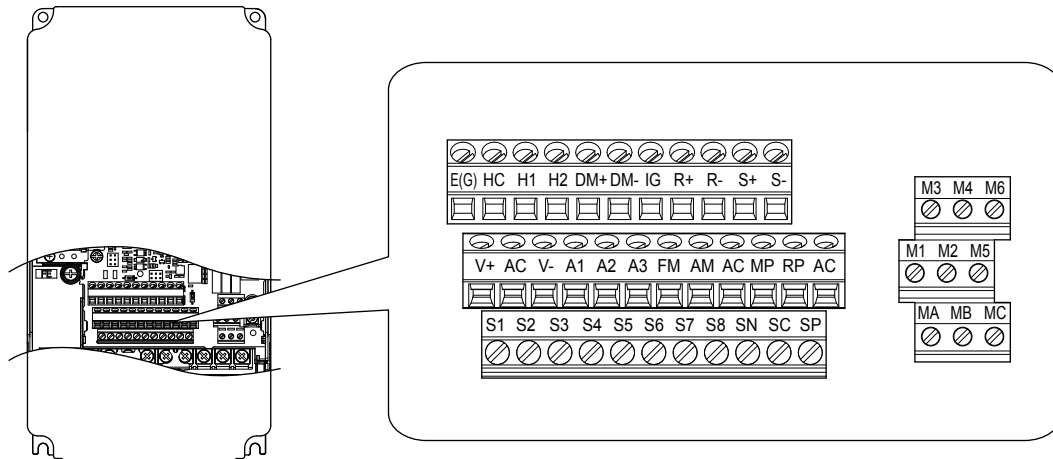

Figure i.11 Control Circuit Terminal Arrangement

### ◆ Control Circuit Input Terminals

**Table i.9** lists the input terminals on the drive. Text in parenthesis indicates the default setting for each multi-function input.

Table i.9 Control Circuit Input Terminals

Type	No.	Terminal Name (Function)	Function (Signal Level) Default Setting
Multi-Function Digital Inputs	S1	Multi-function input 1 (Closed: Forward run, Open: Stop)	<ul style="list-style-type: none"> <li>• Photocoupler</li> <li>• 24 Vdc, 8 mA</li> <li>• <i>Refer to Sinking/Sourcing Mode for Digital Inputs on page 40.</i></li> </ul>
	S2	Multi-function input 2 (Closed: Reverse run, Open: Stop)	
	S3	Multi-function input 3 (External fault, N.O.)	
	S4	Multi-function input 4 (Fault reset)	
	S5	Multi-function input 5 (Multi-step speed reference 1)	
	S6	Multi-function input 6 (Multi-step speed reference 2)	
	S7	Multi-function input 7 (Jog reference)	
	S8	Multi-function input 8 (Baseblock command (N.O.))	
	SC	Multi-function input common	Multi-function input common
	SP	Digital input power supply +24 Vdc	24 Vdc power supply for digital inputs, 150 mA max (only when not using digital input option DI-A3)
	SN	Digital input power supply 0 V	<b>NOTICE:</b> Do not jumper or short terminals SP and SN. Failure to comply will damage the drive.

### i.3 Electrical Installation Safety

Type	No.	Terminal Name (Function)	Function (Signal Level) Default Setting
Safe Disable Inputs	H1	Safe Disable input 1 <1>	<ul style="list-style-type: none"> <li>• 24 Vdc, 8 mA</li> <li>• One or both open: Output disabled</li> <li>• Both closed: Normal operation</li> <li>• Internal impedance: 3.3 kΩ</li> <li>• Off time of at least 1 ms</li> <li>• Disconnect the wire jumpers shorting terminals H1, H2, and HC to use the Safe Disable inputs. Set the S3 jumper to select between sinking, sourcing mode, and the power supply as explained on page 40.</li> </ul>
	H2	Safe Disable input 2 <1>	
	HC	Safe Disable function common	Safe disable function common
Analog Inputs / Pulse Train Input	RP	Multi-function pulse train input (Frequency reference)	<ul style="list-style-type: none"> <li>• Input frequency range: 0 to 32 kHz</li> <li>• Signal Duty Cycle: 30 to 70%</li> <li>• High level: 3.5 to 13.2 Vdc, low level: 0.0 to 0.8 Vdc</li> <li>• Input impedance: 3 kΩ</li> </ul>
	+V	Power supply for analog inputs	10.5 Vdc (max allowable current 20 mA)
	-V	Power supply for analog inputs	-10.5 Vdc (max allowable current 20 mA)
	A1	Multi-function analog input 1 (Frequency reference bias)	-10 to 10 Vdc, 0 to 10 Vdc (input impedance: 20 kΩ)
	A2	Multi-function analog input 2 (Frequency reference bias)	<ul style="list-style-type: none"> <li>• -10 to 10 Vdc, 0 to 10 Vdc (input impedance: 20 kΩ)</li> <li>• 4 to 20 mA, 0 to 20 mA (input impedance: 250 Ω)</li> <li>• Voltage or current input must be selected by DIP switch S1 and H3-09.</li> </ul>
	A3	Multi-function analog input 3 (Auxiliary frequency reference)/PTC Input	<ul style="list-style-type: none"> <li>• -10 to 10 Vdc, 0 to 10 Vdc (input impedance: 20 kΩ)</li> <li>• Use DIP switch S4 on the terminal board to select between analog and PTC input.</li> </ul>
	AC	Frequency reference common	0 V
E (G)	Ground for shielded lines and option cards	–	

<1> Terminals H1, H2, DM+, and DM- on 600 V class models are designed to the functionality, but are not certified to IEC/EN61800-5-1, ISO/EN13849 Cat. 3, IEC/EN61508 SIL2, Insulation coordination: class 1.

### ◆ Control Circuit Output Terminals

Table i.10 lists the output terminals on the drive. Text in parenthesis indicates the default setting for each multi-function output.

Table i.10 Control Circuit Output Terminals

Type	No.	Terminal Name (Function)	Function (Signal Level) Default Setting
Fault Relay Output	MA	N.O. output (Fault)	30 Vdc, 10 mA to 1 A; 250 Vac, 10 mA to 1 A Minimum load: 5 Vdc, 10 mA
	MB	N.C. output (Fault)	
	MC	Fault output common	
Multi-Function Digital Output <1>	M1	Multi-function digital output (During run)	30 Vdc, 10 mA to 1 A; 250 Vac, 10 mA to 1 A Minimum load: 5 Vdc, 10 mA
	M2		
	M3	Multi-function digital output (Zero speed)	
	M4		
	M5	Multi-function digital output (Speed Agree 1)	
M6			
Monitor Output	MP	Pulse train output (Output frequency)	32 kHz (max)
	FM	Analog monitor output 1 (Output frequency)	-10 to +10 Vdc, 0 to +10 Vdc, or 4 to 20 mA. Refer to Terminal AM/FM Signal Selection on page 43 for details.
	AM	Analog monitor output 2 (Output current)	
	AC	Monitor common	0 V
Safety Monitor Output <2>	DM+	Safety monitor output	Outputs status of Safe Disable function. Closed when both Safe Disable channels are closed. Up to +48 Vdc 50 mA
	DM-	Safety monitor output	

<1> Refrain from assigning functions to digital relay outputs that involve frequent switching, as doing so may shorten relay performance life. Switching life is estimated at 200,000 times (assumes 1 A, resistive load).

<2> Terminals H1, H2, DM+, and DM- on 600 V class models are designed to the functionality, but are not certified to IEC/EN61800-5-1, ISO/EN13849 Cat. 3, IEC/EN61508 SIL2, Insulation coordination: class 1.

Connect a suppression diode as shown in Figure i.12 when driving a reactive load such as a relay coil. Ensure the diode rating is greater than the circuit voltage.

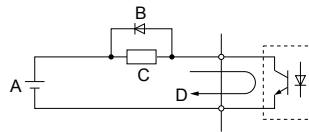

A – External power, 48 V max.  
 B – Suppression diode  
 C – Coil  
 D – 50 mA or less

Figure i.12 Connecting a Suppression Diode

Serial Communication Terminals

Table i.11 Control Circuit Terminals: Serial Communications

Type	No.	Signal Name	Function (Signal Level)	
MEMOBUS/Modbus Communication </>	R+	Communications input (+)	MEMOBUS/Modbus communication: Use an RS-422 or RS-485 cable to connect the drive.	RS-422/RS-485 MEMOBUS/Modbus communication protocol 115.2 kbps (max.)
	R-	Communications input (-)		
	S+	Communications output (+)		
	S-	Communications output (-)		
	IG	Shield ground	0 V	

<1> Enable the termination resistor in the last drive in a MEMOBUS/Modbus network by setting DIP switch S2 to the ON position. Refer to the manual section on **Control I/O Connections** for more information.

Control Circuit Wire Size and Torque Specifications

Select appropriate wire type and gauges from **Table i.12**. For simpler and more reliable wiring, use crimp ferrules on the wire ends. Refer to the Technical Manual on the CD-ROM packaged with the drive for ferrule terminal types and sizes.

Table i.12 Wire Gauges

Terminal	Screw Size	Tightening Torque N•m (lb. in)	Bare Wire Terminal		Ferrule-Type Terminal		Wire Type
			Recomm. wire size mm <sup>2</sup> (AWG)	Applicable wire size mm <sup>2</sup> (AWG)	Recomm. wire size mm <sup>2</sup> (AWG)	Applicable wire size mm <sup>2</sup> (AWG)	
S1-S8, SC, SN, SP	M3	0.5 to 0.6 (4.4 to 5.3)	0.75 (18)	Stranded wire: 0.2 to 1.0 (24 to 16) Solid wire: 0.2 to 1.5 (24 to 16)	0.5 (20)	0.25 to 0.5 (24 to 20)	Shielded wire, etc.
H1, H2, HC							
RP, V+, V-, A1, A2, A3, AC							
MA, MB, MC							
M1-M6							
MP, FM, AM, AC							
DM+, DM-							
R+, R-, S+, S-, IG							

Wiring the Control Circuit Terminal

This section describes the proper procedures and preparations for wiring the control terminals.

**WARNING!** Electrical Shock Hazard. Do not remove covers or touch the circuit boards while the power is on. Failure to comply could result in death or serious injury.

**NOTICE:** Separate control circuit wiring from main circuit wiring (terminals R/L1, S/L2, T/L3, B1, B2, U/T1, V/T2, W/T3, -, +1, +2) and other high-power lines. Improper wiring practices could result in drive malfunction due to electrical interference.

**NOTICE:** Separate wiring for digital output terminals MA, MB, MC, and M1 to M6 from wiring to other control circuit lines. Improper wiring practices could result in drive or equipment malfunction or nuisance trips.

**NOTICE:** Use a class 2 power supply when connecting to the control terminals. Improper application of peripheral devices could result in drive performance degradation due to improper power supply. Refer to NEC Article 725 Class 1, Class 2, and Class 3 Remote-Control, Signaling, and Power Limited Circuits for requirements concerning class 2 power supplies.

**NOTICE:** Insulate shields with tape or shrink tubing to prevent contact with other signal lines and equipment. Improper wiring practices could result in drive or equipment malfunction due to short circuit.

**NOTICE:** Connect the shield of shielded cable to the appropriate ground terminal. Improper equipment grounding could result in drive or equipment malfunction or nuisance trips.

### i.3 Electrical Installation Safety

**NOTICE:** Do not tighten screws beyond the specified tightening torque. Failure to comply may result in erroneous operation, damage to the terminal block, or cause a fire.

**NOTICE:** Use shielded twisted-pair cables as indicated to prevent operating faults. Improper wiring practices could result in drive or equipment malfunction due to electrical interference.

Wire the control circuit only after terminals have been properly grounded and main circuit wiring is complete. *Refer to Terminal Board Wiring Guide on page 38* for details. Prepare the ends of the control circuit wiring as shown in *Figure i.15*. *Refer to Wire Gauges on page 37*.

Connect control wires as shown in *Figure i.13* and *Figure i.14*.

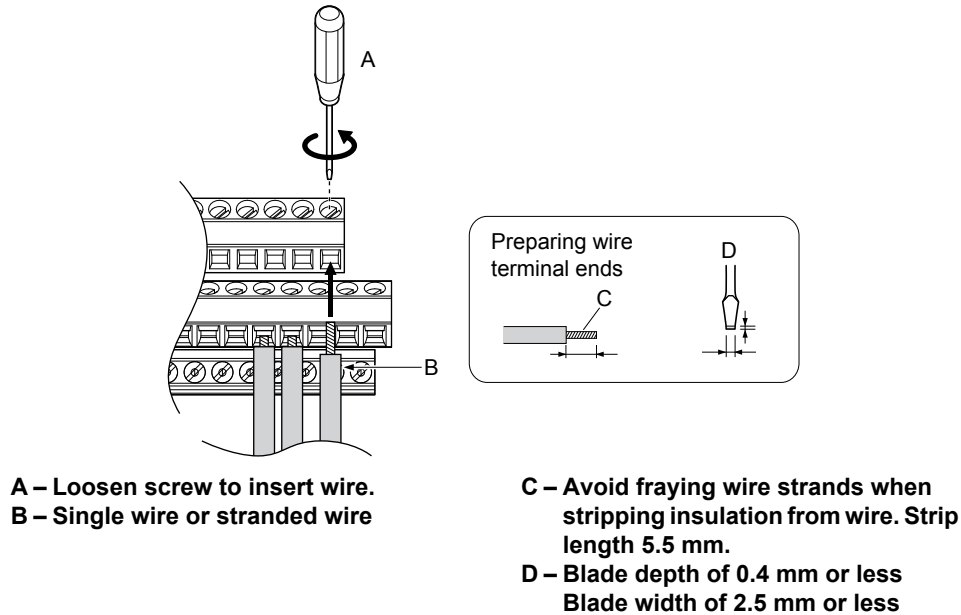

Figure i.13 Terminal Board Wiring Guide

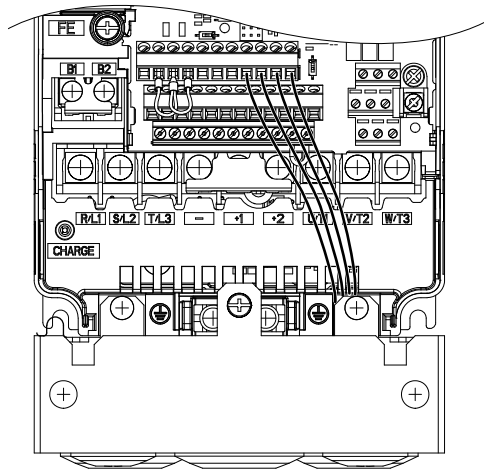
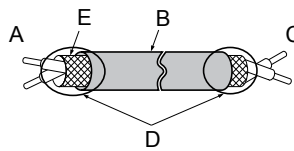

Figure i.14 Terminal Board Location Inside the Drive

When setting the frequency by analog reference from an external potentiometer, use shielded twisted-pair wires (preparing wire ends as shown in *Figure i.15*) and connect the shield to the ground terminal of the drive.



- A – Drive side
- B – Insulation
- C – Control device side
- D – Shield sheath (insulate with tape)
- E – Shield

Figure i.15 Preparing the Ends of Shielded Cables

**NOTICE:** The analog signal wiring between the drive and the operator station or peripheral equipment should not exceed 50 meters when using an analog signal from a remote source to supply the frequency reference. Failure to comply could result in poor system performance.

### ◆ Switches and Jumpers on the Terminal Board

The terminal board is equipped with several switches used to adapt the drive I/Os to the external control signals. *Figure i.16* shows the location of these switches.

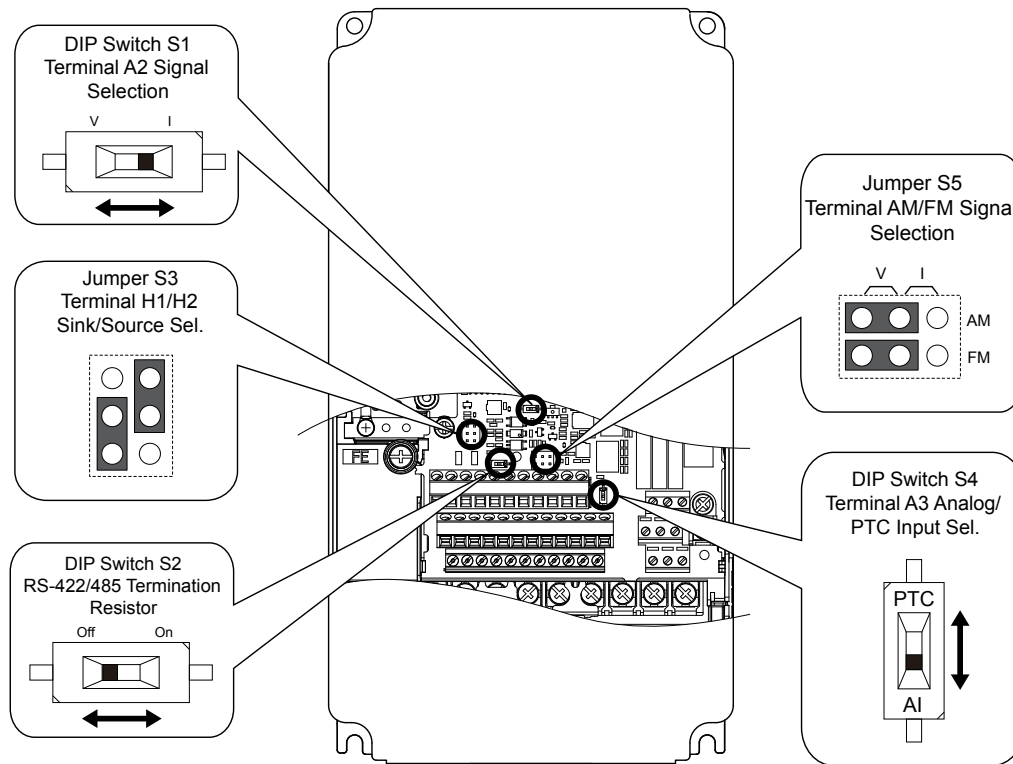

Figure i.16 Locations of Jumpers and Switches on the Terminal Board

**◆ Sinking/Sourcing Mode for Digital Inputs**

Use the wire jumper between terminals SC and SP or SC and SN to select between Sink mode, Source mode or external power supply for the digital inputs S1 to S8 as shown in **Table i.13** (Default: Sink mode, internal power supply).

**NOTICE:** Do not short terminals SP and SN. Failure to comply will damage the drive.

**Table i.13 Digital Input Sink/Source/External Power Supply Selection**

Mode	Drive Internal Power Supply (Terminals SN and SP)	External 24 Vdc Power Supply
Sinking Mode (NPN)		
Sourcing Mode (PNP)		

**◆ Sinking/Sourcing Mode Selection for Safe Disable Inputs**

**Note:** Terminals H1, H2, DM+, and DM- on 600 V class models are designed to the functionality, but are not certified to IEC/EN61800-5-1, ISO/EN13849 Cat. 3, IEC/EN61508 SIL2, Insulation coordination: class 1.

Use jumper S3 on the terminal board to select between Sink mode, Source mode or external power supply for the Safe Disable inputs H1 and H2 as shown in **Table i.14** (Default: Source mode, internal power supply).



Table i.14 Safe Disable Input Sink/Source/External Power Supply Selection

Mode	Drive Internal Power Supply	External 24 Vdc Power Supply
Sinking Mode		
Sourcing Mode		

■ Using External Power Supply (Sink Mode)

The high voltage level of the pulse output signal depends on the external voltage applied. The voltage must be between 12 and 15 Vdc. The load resistance must be adjusted so that the current is lower than 16 mA.

External Power Supply (V)	Load Impedance (kΩ)
12 to 15 Vdc ±10%	1.0 kΩ or higher

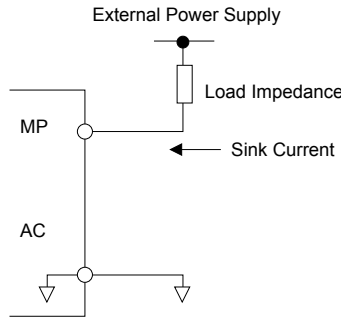

Figure i.17 Pulse Output Connection Using External Voltage Supply

◆ Terminal A2 Input Signal Selection

Terminal A2 can be used to input either a voltage or a current signal. Select the signal type using switch S1 as explained in [Table i.15](#). Set parameter H3-09 accordingly as shown in [Table i.16](#).

**Note:** If terminals A1 and A2 are both set for frequency bias (H3-02 = 0 and H3-10 = 0), both input values will be combined to create the frequency reference.

Table i.15 DIP Switch S1 Settings

Setting	Description
V (left position)	Voltage input (-10 to +10 V or 0 to 10 V)
I (right position)	Current input (4 to 20 mA or 0 to 20 mA): default setting

**Table i.16 Parameter H3-09 Details**

No.	Parameter Name	Description	Setting Range	Default Setting
H3-09	Terminal A2 signal level selection	Selects the signal level for terminal A2. 0: 0 to 10 Vdc 1: -10 to 10 Vdc 2: 4 to 20 mA 3: 0 to 20 mA	0 to 3	2

#### ◆ Terminal A3 Analog/PTC Input Selection

Terminal A3 can be configured either as multi-function analog input or as PTC input for motor thermal overload protection. Use switch S4 to select the input function as described in [Table i.17](#).

**Table i.17 DIP Switch S4 Settings**

Setting	Description
AI (lower position) (default)	Analog input for the function selected in parameter H3-06
PTC (upper position)	PTC input. Parameter H3-06 must be set to E (PTC input)

### ◆ Terminal AM/FM Signal Selection

The signal type for terminals AM and FM can be set to either voltage or current output using jumper S5 on the terminal board as explained in [Table i.18](#). When changing the setting of jumper S5, parameters H4-07 and H4-08 must be set accordingly. The default selection is voltage output for both terminals.

Table i.18 Jumper S5 Settings

Terminal	Voltage Output	Current Output
Terminal AM		
Terminal FM		

Table i.19 Parameter H4-07 and H4-08 Details

No.	Parameter Name	Description	Setting Range	Default Setting
H4-07	Terminal AM signal level selection	0: 0 to 10 Vdc	0 to 2	0
H4-08	Terminal FM signal level selection	1: -10 to 10 Vdc 2: 4 to 20 mA		

### ◆ MEMOBUS/Modbus Termination

This drive is equipped with a built-in termination resistor for the RS-422/485 communication port. DIP switch S2 enables or disabled the termination resistor as shown in [Table i.20](#). The OFF position is the default. The termination resistor should be placed to the ON position when the drive is the last in a series of slave drives. [Refer to Switches and Jumpers on the Terminal Board on page 39](#) to locate switch S2.

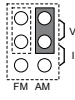
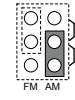
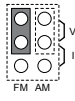
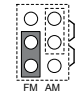
Table i.20 MEMOBUS/Modbus Switch Settings

S2 Position	Description
ON	Internal termination resistor ON
OFF	Internal termination resistor OFF (default setting)

## i.4 Troubleshooting

### NOTICE

Refer to the A1000 Technical Manual SIEPC71061641 on the CD-ROM packaged with the product for information on **Troubleshooting** and complete product instructions necessary for proper installation, set-up, troubleshooting and maintenance. CD part number TOECC71061615.

### WARNING

#### Electrical Shock Hazard

**Do not connect or disconnect wiring while the power is on.**

Failure to comply could result in death or serious injury.

Before servicing, disconnect all power to the equipment. The internal capacitor remains charged even after the power supply is turned off. The charge indicator LED will extinguish when the DC bus voltage is below 50 Vdc. To prevent electric shock, wait for at least the time specified on the warning label; after all indicators are OFF, measure for unsafe voltages to confirm the drive is safe prior to servicing.

**Do not operate equipment with covers removed.**

Failure to comply could result in death or serious injury.

The diagrams in this section may illustrate drives without covers or safety shields to display details. Be sure to reinstall covers or shields before operating the drives and run the drives according to the instructions described in this manual.

**Do not touch terminals before the capacitors have fully discharged.**

Failure to comply could result in death or serious injury.

Before servicing, disconnect all power to the equipment. The internal capacitor remains charged even after the power supply is turned off. The charge indicator LED will extinguish when the DC bus voltage is below 50 Vdc. To prevent electric shock, wait for at least the time specified on the warning label; after all indicators are OFF, measure for unsafe voltages to confirm the drive is safe prior to servicing.

**After blowing a fuse or tripping a GFCI, do not attempt to restart the drive or operate peripheral devices until five minutes pass and CHARGE lamp is OFF.**

Failure to comply could result in death, serious injury, and damage to the drive.

Check wiring and peripheral device ratings to identify the cause of trips.

Contact your supplier if the cause cannot be identified.

Installation, maintenance, inspection and servicing must be performed only by authorized personnel familiar with installation, adjustment and maintenance of AC drives.

**Do not perform work on the drive while wearing loose clothing, jewelry, or without eye protection.**

Failure to comply could result in death or serious injury.

**Do not remove covers or touch circuit boards while the power is on.**

Failure to comply could result in death or serious injury.

## ◆ Fault Reset Methods

When a fault occurs, the cause of the fault must be removed and the drive must be restarted. The table below lists the different ways to restart the drive.

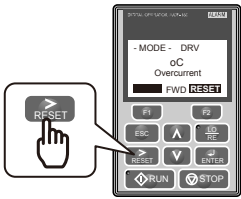
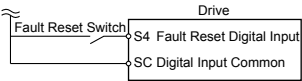
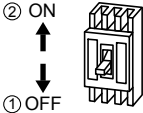
After the Fault Occurs	Procedure	
Fix the cause of the fault, restart the drive, and reset the fault	Press  on the digital operator when the error code is displayed.	
Resetting via Fault Reset Digital Input S4	Close then open the fault signal digital input via terminal S4. S4 is set for “Fault Reset” as default (H1-04 = 14).	
Turn off the main power supply if the above methods do not reset the fault. Reapply power after the digital operator display has turned off.		

**Note:** If the Run command is present, the drive will disregard any attempts to reset the fault. Remove the Run command before attempting to clear a fault situation.

## i.5 UL and CSA Standards

### ◆ UL Standards Compliance

The UL/cUL mark applies to products in the United States and Canada. It indicates that UL has performed product testing and evaluation, and determined that their stringent standards for product safety have been met. For a product to receive UL certification, all components inside that product must also receive UL certification.



Figure i.18 UL/cUL Mark

This drive is tested in accordance with UL standard UL508C and complies with UL requirements. The conditions described below must be met to maintain compliance when using this drive in combination with other equipment:

#### ■ Installation Area

Do not install the drive to an area greater than pollution degree 2 (UL standard).

#### ■ Ambient Temperature

IP20/NEMA Type 1 Enclosure: -10 to +40 °C

IP00 Open Type Enclosure: -10 to +50 °C

#### ■ Main Circuit Terminal Wiring

Yaskawa recommends using closed-loop crimp terminals on all drive models. To maintain UL/cUL approval, UL Listed closed-loop crimp terminals are specifically required when wiring the drive main circuit terminals on models 2A0110 to 2A0415, 4A0058 to 4A0675, (4A1200 series dependant), and 5A0041 to 5A0242. Use only the tools recommended by the terminal manufacturer for crimping. Refer to *Closed-Loop Crimp Terminal* section of the drive Technical Manual for closed-loop crimp terminal recommendations.

#### Wire Gauges and Tightening Torques

*Refer to Main Circuit Wire Gauges and Tightening Torque on page 22.*

#### Closed-Loop Crimp Terminal Recommendations

*Refer to Closed-Loop Crimp Terminal Recommendations on page 29.*

#### Factory Recommended Branch Circuit Protection for UL Compliance

**NOTICE:** *If a fuse is blown or a Ground Fault Circuit Interrupter (GFCI) is tripped, check the wiring and the selection of the peripheral devices. Check the wiring and the selection of peripheral devices to identify the cause. Contact Yaskawa before restarting the drive or the peripheral devices if the cause cannot be identified.*

Yaskawa recommends installing one of the following types of branch circuit protection to maintain compliance with UL508C. Semiconductor protective type fuses are preferred. Alternate branch circuit protection devices are also listed in the tables below.

Table i.21 Factory Recommended A1000 AC Drive Branch Circuit Protection (Normal Duty)

Drive Model	A1000 in Normal Duty Mode (C6-01 = 1)					
	Nominal Output Power HP	AC Drive Input Amps	MCCB Rating Amps <1>	Time Delay Fuse Rating Amps <2>	Non-time Delay Fuse Rating Amps <3>	Bussman Semiconductor Fuse Rating (Fuse Ampere) <4>
<b>200 V Class</b>						
2A0004	0.75	3.9	15	6.25	10	FWH-70B (70)
2A0006	1 - 1.5	7.3	15	12	20	FWH-70B (70)
2A0008	2	8.8	15	15	25	FWH-70B (70)
2A0010	3	10.8	20	17.5	30	FWH-70B (70)

Drive Model	A1000 in Normal Duty Mode (C6-01 = 1)					
	Nominal Output Power HP	AC Drive Input Amps	MCCB Rating Amps <1>	Time Delay Fuse Rating Amps <2>	Non-time Delay Fuse Rating Amps <3>	Bussman Semiconductor Fuse Rating (Fuse Ampere) <4>
2A0012	3	13.9	25	20	40	FWH-70B (70)
2A0018	5	18.5	35	30	50	FWH-90B(90)
2A0021	7.5	24	45	40	70	FWH-90B(90)
2A0030	10	37	60	60	110	FWH-100B (100)
2A0040	15	52	100	90	150	FWH-200B (200)
2A0056	20	68	125	110	200	FWH-200B (200)
2A0069	25	80	150	125	225	FWH-200B (200)
2A0081	30	96	175	150	275	FWH-300A (300)
2A0110	40	111	200	175	300	FWH-300A (300)
2A0138	50	136	250	225	400	FWH-350A (350)
2A0169	60	164	300	250	450	FWH-400A (400)
2A0211	75	200	400	350	600	FWH-400A (400)
2A0250	100	271	500	450	800	FWH-600A (600)
2A0312	125	324	600	500	800	FWH-700A (700)
2A0360	150	394	700	600	1000 <5>	FWH-800A (800)
2A0415	175	471	900	800	1400 <5>	FWH-1000A (1000)
<b>400 V Class</b>						
4A0002	1	2.1	15	3.5	6	FWH-40B (40)
4A0004	2	4.3	15	7.5	12	FWH-50B (50)
4A0005	3	5.9	15	10	17.5	FWH-70B (70)
4A0007	3	8.1	15	12	20	FWH-70B (70)
4A0009	5	9.4	15	15	25	FWH-90B (90)
4A0011	7.5	14	25	20	40	FWH-90B (90)
4A0018	10	20	40	35	60	FWH-80B (80)
4A0023	15	24	45	40	70	FWH-100B (100)
4A0031	20	38	75	60	110	FWH-125B (125)
4A0038	25	44	75	75	125	FWH-200B (200)
4A0044	30	52	100	90	150	FWH-250A (250)
4A0058	40	58	100	100	150	FWH-250A (250)
4A0072	50	71	125	110	200	FWH-250A (250)
4A0088	60	86	150	150	250	FWH-250A (250)
4A0103	75	105	200	175	300	FWH-250A (250)
4A0139	100	142	250	225	400	FWH-350A (350)
4A0165	125	170	300	250	500	FWH-400A (400)
4A0208	150	207	400	350	600	FWH-500A (500)
4A0250	200	248	450	400	700	FWH-600A (600)
4A0296	250	300	600	500	800	FWH-700A (700)
4A0362	300	346	600	600	1000 <5>	FWH-800A (800)
4A0414	350	410	800	700	1200 <5>	FWH-800A (800)
4A0515	400 - 450	465	900	800	1350 <5>	FWH-1000A (1000)
4A0675	500 - 600	657	1200	1100 <5>	1800 <5>	FWH-1200A (1200)
4A0930	700 - 800	922	Not Applicable			FWH-1200A (1200)
4A1200	900 - 1000	1158				FWH-1600A (1600)
<b>600 V Class</b>						
5A0003	2	3.6	15	6.25	10	FWP-50B (50)
5A0004	3	5.1	15	8	15	FWP-50B (50)

## i.5 UL and CSA Standards

Drive Model	A1000 in Normal Duty Mode (C6-01 = 1)					
	Nominal Output Power HP	AC Drive Input Amps	MCCB Rating Amps <1>	Time Delay Fuse Rating Amps <2>	Non-time Delay Fuse Rating Amps <3>	Bussman Semiconductor Fuse Rating (Fuse Ampere) <4>
5A0006	5	8.3	15	12	20	FWP-60B (60)
5A0009	7.5	12	20	20	35	FWP-60B (60)
5A0011	10	16	30	25	45	FWP-70B (70)
5A0017	15	23	40	40	60	FWP-100B (100)
5A0022	20	31	60	50	90	FWP-100B (100)
5A0027	25	38	75	60	110	FWP-125A (125)
5A0032	30	45	75	75	125	FWP-125A (125)
5A0041	40	44	75	75	125	FWP-175A (175)
5A0052	50	54	100	90	150	FWP-175A (175)
5A0062	60	66	125	110	175	FWP-250A (250)
5A0077	75	80	150	125	225	FWP-250A (250)
5A0099	100	108	175	175	300	FWP-250A (250)
5A0125	125	129	225	225	350	FWP-350A (350)
5A0145	150	158	300	275	450	FWP-350A (350)
5A0192	200	228	400	350	600	FWP-600A (600)
5A0242	250	263	500	450	700	FWP-600A (600)

- <1> Maximum MCCB Rating is 15 A, or 200 % of drive input current rating, whichever is larger. MCCB voltage rating must be 600 VAC or greater.
- <2> Maximum Time Delay fuse is 175% of drive input current rating. This covers any Class CC, J or T class fuse.
- <3> Maximum Non-time Delay fuse is 300% of drive input current rating. This covers any CC, J or T class fuse.
- <4> When using semiconductor fuses, Bussman FWH and FWP are required for UL compliance. Select FWH for 200 V Class and 400 V Class models and FWP fuses for 600 V models.
- <5> Class L fuse is also approved for this rating.

**Table i.22 Factory Recommended A1000 AC Drive Branch Circuit Protection (Heavy Duty)**

Drive Model	A1000 in Heavy Duty Mode (C6-01 = 0)					
	Nominal Output Power HP	AC Drive Input Amps	MCCB Rating Amps <1>	Time Delay Fuse Rating Amps <2>	Non-time Delay Fuse Rating Amps <3>	Bussman Semiconductor Fuse Rating (Fuse Ampere) <4>
<b>200 V Class</b>						
2A0004	0.75	2.9	15	5	8	FWH-70B (70)
2A0006	1	5.8	15	10	15	FWH-70B (70)
2A0008	2	7	15	12	17.5	FWH-70B (70)
2A0010	2	7.5	15	12	20	FWH-70B (70)
2A0012	3	11	20	17.5	30	FWH-70B (70)
2A0018	3	15.6	25	25	40	FWH-90B(90)
2A0021	5	18.9	35	30	50	FWH-90B(90)
2A0030	7.5	28	50	40	75	FWH-100B (100)
2A0040	10	37	60	60	100	FWH-200B (200)
2A0056	15	52	100	90	150	FWH-200B (200)
2A0069	20	68	125	110	200	FWH-200B (200)
2A0081	25	80	150	125	225	FWH-300A (300)
2A0110	30	82	150	125	225	FWH-300A (300)
2A0138	40	111	200	175	250	FWH-350A (350)
2A0169	50	136	250	225	350	FWH-400A (400)
2A0211	60	164	300	250	450	FWH-400A (400)
2A0250	75	200	400	350	600	FWH-600A (600)
2A0312	100	271	500	450	800	FWH-700A (700)
2A0360	125	324	600	500	900 <4>	FWH-800A (800)



Drive Model	A1000 in Heavy Duty Mode (C6-01 = 0)					
	Nominal Output Power HP	AC Drive Input Amps	MCCB Rating Amps <1>	Time Delay Fuse Rating Amps <2>	Non-time Delay Fuse Rating Amps <3>	Bussman Semiconductor Fuse Rating (Fuse Ampere) <4>
2A0415	150	394	700	600	1100 <4>	FWH-1000A (1000)
<b>400 V Class</b>						
4A0002	0.75	1.8	15	3	5	FWH-40B (40)
4A0004	1 - 2	3.2	15	5	9	FWH-50B (50)
4A0005	3	4.4	15	7	12	FWH-70B (70)
4A0007	3	6	15	10	17.5	FWH-70B (70)
4A0009	5	8.2	15	12	20	FWH-90B (90)
4A0011	5	10.4	20	17.5	30	FWH-90B (90)
4A0018	7.5 - 10	15	30	25	40	FWH-80B (80)
4A0023	10	20	40	35	60	FWH-100B (100)
4A0031	15	29	50	50	80	FWH-125B (125)
4A0038	20	39	75	60	110	FWH-200B (200)
4A0044	25 - 30	47	75	75	125	FWH-250A (250)
4A0058	30	43	75	75	125	FWH-250A (250)
4A0072	40	58	100	100	150	FWH-250A (250)
4A0088	60	71	125	110	200	FWH-250A (250)
4A0103	60	86	150	150	250	FWH-250A (250)
4A0139	75	105	175	175	300	FWH-350A (350)
4A0165	100	142	225	225	400	FWH-400A (400)
4A0208	125 - 150	170	250	250	500	FWH-500A (500)
4A0250	150	207	350	350	600	FWH-600A (600)
4A0296	200	248	400	400	700	FWH-700A (700)
4A0362	250	300	500	500	800	FWH-800A (800)
4A0414	300	346	600	600	1000 <4>	FWH-800A (800)
4A0515	350	410	700	700	1200 <4>	FWH-1000A (1000)
4A0675	400 - 500	584	1000	1000 <4>	1600 <4>	FWH-1200A (1200)
4A0930	600 - 700	830	Not Applicable			FWH-1200A (1200)
4A1200	800 - 900	1031				FWH-1600A (1600)
<b>600 V Class</b>						
5A0003	1	1.9	15	3	5	FWP-50B (50)
5A0004	2	3.6	15	6.25	10	FWP-50B (50)
5A0006	3	5.1	15	8	15	FWP-60B (60)
5A0009	5	8.3	15	12	20	FWP-60B (60)
5A0011	7.5	12	20	20	35	FWP-70B (70)
5A0017	10	16	30	25	45	FWP-100B (100)
5A0022	15	23	40	40	60	FWP-100B (100)
5A0027	20	31	60	50	90	FWP-125A (125)
5A0032	25	38	75	60	100	FWP-125A (125)
5A0041	30	33	60	50	90	FWP-175A (175)
5A0052	40	44	75	75	125	FWP-175A (175)
5A0062	50	54	100	90	150	FWP-250A (250)
5A0077	60	66	125	110	175	FWP-250A (250)
5A0099	75	80	150	125	225	FWP-250A (250)
5A0125	100	108	175	175	300	FWP-350A (350)
5A0145	125	129	250	225	350	FWP-350A (350)
5A0192	150	158	300	250	400	FWP-600A (600)

## i.5 UL and CSA Standards

Drive Model	A1000 in Heavy Duty Mode (C6-01 = 0)					
	Nominal Output Power HP	AC Drive Input Amps	MCCB Rating Amps <1>	Time Delay Fuse Rating Amps <2>	Non-time Delay Fuse Rating Amps <3>	Bussman Semiconductor Fuse Rating (Fuse Ampere) <4>
5A0242	200	228	400	350	600	FWP-600A (600)

<1> Maximum MCCB Rating is 15 A, or 200 % of drive input current rating, whichever is larger. MCCB voltage rating must be 600 VAC or greater.

<2> Maximum Time Delay fuse is 175% of drive input current rating. This covers any Class CC, J or T class fuse.

<3> Maximum Non-time Delay fuse is 300% of drive input current rating. This covers any CC, J or T class fuse.

<4> Class L fuse is also approved for this rating.

### ■ Low Voltage Wiring for Control Circuit Terminals

Wire low voltage wires with NEC Class 1 circuit conductors. Refer to national state or local codes for wiring. The external power supply shall be a UL listed Class 2 power supply source or equivalent only.

Table i.23 Control Circuit Terminal Power Supply

Input / Output	Terminal Signal	Power Supply Specifications
Open Collector Outputs	P1, P2, PC, DM+, DM-	Requires class 2 power supply
Digital inputs	S1 to S8, SC, HC, H1, H2	Use the internal LVLC power supply of the drive. Use class 2 for external power supply.
Analog inputs / outputs	+V, -V, A1, A2, A3, AC, AM, FM	Use the internal LVLC power supply of the drive. Use class 2 for external power supply.

### ■ Drive Short Circuit Rating

The drive is suitable for use on a circuit capable of delivering not more than 100,000 RMS symmetrical Amperes, 240 Vac maximum (200 V Class), 480 Vac maximum (400 V Class), and 600 Vac maximum (600 V Class) when protected by Factory recommended branch circuit protection as specified in this document.

## ◆ CSA Standards Compliance



Figure i.19 CSA Mark

### ■ CSA for Industrial Control Equipment

The drive is CSA-certified as Industrial Control Equipment Class 3211.

Specifically, the drive is certified to: CAN/CSA C22.2 No. 04-04 and CAN/CSA C22.2 No.14-05.

## ◆ Drive Motor Overload Protection

Set parameter E2-01 (motor rated current) to the appropriate value to enable motor overload protection. The internal motor overload protection is UL listed and in accordance with the NEC and CEC.

### ■ E2-01: Motor Rated Current

Setting Range: Model-dependent

Default Setting: Model-dependent

Parameter E2-01 protects the motor when parameter L1-01 is not set to 0. The default for L1-01 is 1, which enables protection for standard induction motors.

If Auto-Tuning has been performed successfully, the motor data entered to T1-04 is automatically written to parameter E2-01. If Auto-Tuning has not been performed, manually enter the correct motor rated current to parameter E2-01.

### ■ L1-01: Motor Overload Protection Selection

The drive has an electronic overload protection function (oL1) based on time, output current, and output frequency that protects the motor from overheating. The electronic thermal overload function is UL-recognized, so it does not require an external thermal relay for single motor operation.

This parameter selects the motor overload curve used according to the type of motor applied.

**Table i.24 Overload Protection Settings**

Setting	Description	
0	Disabled	Disabled the internal motor overload protection of the drive.
1	Standard fan-cooled motor (default)	Selects protection characteristics for a standard self-cooled motor with limited cooling capabilities when running below the rated speed. The motor overload detection level (oL1) is automatically reduced when running below the motor rated speed.
2	Drive duty motor with a speed range of 1:10	Selects protection characteristics for a motor with self-cooling capability within a speed range of 10:1. The motor overload detection level (oL1) is automatically reduced when running below 1/10 of the motor rated speed.
3	Vector motor with a speed range of 1:100	Selects protection characteristics for a motor capable of cooling itself at any speed including zero speed (externally cooled motor). The motor overload detection level (oL1) is constant over the entire speed range.
4	Permanent Magnet motor with variable torque	Selects protection characteristics for a variable torque PM motor. The motor overload detection level (oL1) is automatically reduced when running below the motor rated speed.
5	Permanent Magnet motor with constant torque	Selects protection characteristics for a constant torque PM motor. The motor overload detection level (oL1) is constant over the whole speed range.
6	Standard fan-cooled motor (50 Hz)	Selects protection characteristics for a standard self-cooled motor with limited cooling capabilities when running below the rated speed. The motor overload detection level (oL1) is automatically reduced when running below the motor rated speed.

When connecting the drive to more than one motor for simultaneous operation, disable the electronic overload protection (L1-01 = 0) and wire each motor with its own motor thermal overload relay.

Enable motor overload protection (L1-01 = 1 to 6) when connecting the drive to a single motor, unless another motor overload preventing device is installed. The drive electronic thermal overload function causes an oL1 fault, which shuts off the output of the drive and prevents additional overheating of the motor. The motor temperature is continually calculated while the drive is powered up.

### ■ L1-02: Motor Overload Protection Time

Setting Range: 0.1 to 5.0 min

Factory Default: 1.0 min

Parameter L1-02 determines how long the motor is allowed to operate before the oL1 fault occurs when the drive is running a hot motor at 60 Hz and at 150% of the full load amp rating (E2-01) of the motor. Adjusting the value of L1-02 can shift the set of oL1 curves up the y axis of the diagram below, but will not change the shape of the curves.

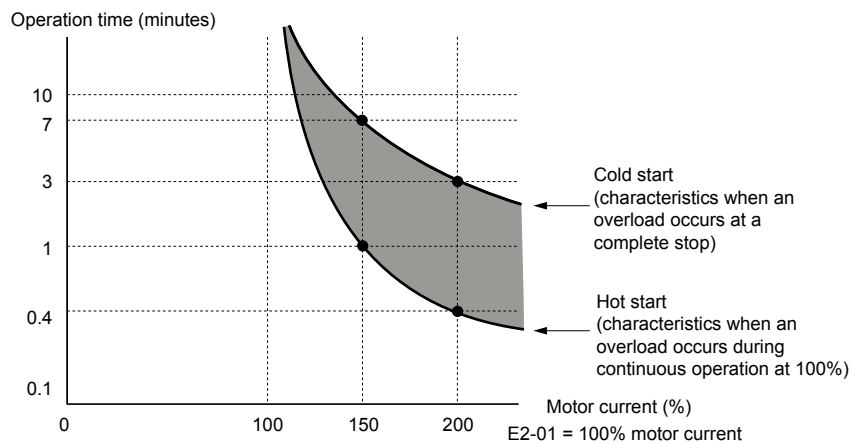

**Figure i.20 Motor Overload Protection Time**

### ◆ **Precautionary Notes on External Heatsink (IP00/Open Type Enclosure)**

When using an external heatsink, UL compliance requires covering exposed capacitors in the main circuit to prevent injury to surrounding personnel.

#### NOTICE

Refer to the A1000 Technical Manual SIEPC71061641 on the CD-ROM packaged with the product for more information regarding *Precautionary Notes on External Heatsink* and complete product instructions necessary for proper installation, set-up, troubleshooting and maintenance. CD part number TOECC71061615.

## ◆ Safe Disable Input Function

### NOTICE

Refer to the A1000 Technical Manual SIEPC71061641 on the CD-ROM packaged with the product for more information on the **Safe Disable Input Function** and complete product instructions necessary for proper installation, set-up, troubleshooting and maintenance. CD part number TOECC71061615.

## ◆ Specifications

<b>Inputs/Outputs</b>		Two Safe Disable inputs and one EDM output according to ISO/EN13849–1 Cat. 3 PLd, IEC/EN61508 SIL2. </>
<b>Operation Time</b>		Time from input open to drive output stop is less than 1 ms.
<b>Failure Probability</b>	<b>Demand Rate Low</b>	PFD = 5.15E <sup>-5</sup>
	<b>Demand Rate High/Continuous</b>	PFH = 1.2E <sup>-9</sup>
<b>Performance Level</b>		The Safe Disable inputs satisfy all requirements of Performance Level (PL) d according to ISO/EN13849-1 (DC from EDM considered). </>

<1> Terminals H1, H2, DM+, and DM- on 600 V class models are designed to the functionality, but are not certified to IEC/EN61800-5-1, ISO/EN13849 Cat. 3, IEC/EN61508 SIL2, Insulation coordination: class 1.

## ◆ Precautions

**Note:** Terminals H1, H2, DM+, and DM- on 600 V class models are designed to the functionality, but are not certified to IEC/EN61800-5-1, ISO/EN13849 Cat. 3, IEC/EN61508 SIL2, Insulation coordination: class 1.

**DANGER! Sudden Movement Hazard.** Improper use of the Safe Disable function can result in serious injury or even death. Make sure the whole system or machinery in which the Safe Disable function is used complies with safety requirements. When implementing the Safe Disable function into the safety system of a machine, perform a thorough risk assessment for the entire system to assure compliance with relevant safety norms.

**DANGER! Sudden Movement Hazard.** When using a PM motor, even if the drive output is shut off by the Safe Disable function, a breakdown of two output transistors can cause current to flow through the motor winding, resulting in a rotor movement for a maximum angle of 180 degrees (electrically). Make sure such a situation would have no effect on the safety of the application when using the Safe Disable function.

**DANGER! Sudden Movement Hazard.** The Safe Disable function can switch off the drive output, but does not cut the drive power supply and cannot electrically isolate the drive output from the input. Always shut off the drive power supply when performing maintenance or installations on the drive input side as well as the drive output side.

**WARNING! Sudden Movement Hazard.** When using the Safe Disable inputs, make sure to remove the wire links between terminals H1, H2, and HC that were installed prior to shipment. Failing to do so will keep the Safe Disable circuit from operating properly and can cause injury or even death.

**NOTICE:** All safety features (including Safe Disable) should be inspected daily and periodically. If the system is not operating normally, there is a risk of serious personal injury.

**NOTICE:** Only a qualified technician with a thorough understanding of the drive, the instruction manual, and safety standards should be permitted to wire, inspect, and maintain the Safe Disable input.

**NOTICE:** From the moment terminal inputs H1 and H2 have opened, it takes up to 1 ms for drive output to shut off completely. The sequence set up to trigger terminals H1 and H2 should make sure that both terminals remain open for at least 1 ms in order to properly interrupt drive output.

**NOTICE:** The Safe Disable Monitor (output terminals DM+ and DM-) should not be used for any other purpose than to monitor the Safe Disable status or to discover a malfunction in the Safe Disable inputs. The monitor output is not considered a safe output.

**NOTICE:** When utilizing the Safe Disable function, an EMC filter must be used. Use only the EMC filters recommended in the drive Technical Manual.

## ◆ Safe Disable Digital Operator Display

When both Safe Disable inputs are open, “Hbb” will flash in the digital operator display.

If one Safe Disable channel is on while the other is off, “HbbF” will flash in the display to indicate that there is a problem in the safety circuit or in the drive. This display should not appear under normal conditions if the Safe Disable circuit is utilized properly.

## i.6 European Standards



Figure i.21 CE Mark

The CE mark indicates compliance with European safety and environmental regulations. It is required for engaging in business and commerce in Europe.

European standards include the Machinery Directive for machine manufacturers, the Low Voltage Directive for electronics manufacturers, and the EMC guidelines for controlling noise.

This drive displays the CE mark based on the EMC guidelines and the Low Voltage Directive.

- **Low Voltage Directive:** 2006/95/EC
- **EMC Guidelines:** 2004/108/EC

Devices used in combination with this drive must also be CE certified and display the CE mark. When using drives displaying the CE mark in combination with other devices, it is ultimately the responsibility of the user to ensure compliance with CE standards. After setting up the device, verify that conditions meet European standards.

**Note:** 600 V class drives (models 5□□□□□□) are not compliant with European Standards.

### ◆ CE Low Voltage Directive Compliance

This drive has been tested according to European standard IEC/EN61800-5-1, and it fully complies with the Low Voltage Directive.

To comply with the Low Voltage Directive, be sure to meet the following conditions when combining this drive with other devices:

#### ■ Area of Use

Do not use drives in areas with pollution higher than severity 2 and overvoltage category 3 in accordance with IEC/EN664.

#### ■ Factory Recommended Branch Circuit Protection for CE LVD Compliance

#### NOTICE

Refer to the A1000 Technical Manual SIEPC71061641 on the CD-ROM No. TOECC71061615 packaged with the product; Chapter- *Standards Compliance, Section-European Standards* , for more information on *Factory Recommended Branch Circuit Protection* for CE Compliance.

#### ■ Grounding

The drive is designed to be used in T-N (grounded neutral point) networks. If installing the drive in other types of grounded systems, contact your Yaskawa representative for instructions.

#### ■ Guarding Against Harmful Materials

When installing IP00/Open Type enclosure drives, use an enclosure that prevents foreign material from entering the drive from above or below.

## ◆ EMC Guidelines Compliance

This drive is tested according to European standards IEC/EN 61800-3: 2004.

### ■ EMC Filter and DC Link Chokes for IEC/EN 61000-3-2 Compliance

EMC filter and DC link choke requirements must be met to ensure continued compliance with CE guidelines.

#### NOTICE

Refer to the A1000 Technical Manual SIEPC71061641 on the CD-ROM packaged with the product for more information on *EMC Filter Installation* and complete product instructions necessary for proper installation, set-up, troubleshooting and maintenance. CD part number TOECC71061615.

## ◆ Drive Derating Data

### ■ Single-Phase Derating

A1000 drives are optimized and compatible for use with both three-phase and single-phase input power supplies. The A1000 output to the motor is fixed at three-phase.

A1000 output capacity to the motor is reduced or derated when single-phase input power is used.

Refer to the drive **Technical Manual - Drive Derating Data section** to assist in model selection when using the drive in single-phase input power applications.

### ■ Rated Current Depending on Carrier Frequency

#### Normal Duty Rating (ND)

Increasing the carrier frequency above 2 kHz will reduce the ND rated output current of the drive.

#### Heavy Duty Rating (HD)

A carrier frequency setting of 8 kHz or lower is equal to the drive rated current shown on the drive nameplate. The factory default setting for carrier frequency in HD mode is 2 kHz. Increasing the carrier frequency above 8 kHz will reduce the HD rated output current of the drive.

#### NOTICE

Refer to the A1000 Technical Manual – *Drive Derating Data section* to assist in model selection and adjustment when the application requires changing the drives carrier frequency from factory defaults.

## ◆ Temperature Derating

To ensure the maximum performance life, the drive output current must be derated as shown in [Figure i.22](#) when the drive is installed in areas with high ambient temperature or if drives are mounted side-by-side in a cabinet. In order to ensure reliable drive overload protection, set parameters L8-12 and L8-35 according to the installation conditions.

### ■ Parameter Settings

No.	Name	Description	Range	Def.
L8-12	Ambient Temperature Setting	Adjust the drive overload (oL2) protection level when the drive is installed in an environment that exceeds its ambient temperature rating.	-10 to +50	+40 °C
L8-35	Installation Method Selection	0: IP00/Open-Chassis Enclosure 1: Side-by-Side Mounting 2: IP20/NEMA Type 1 Enclosure 3: Finless Drive or External Heatsink Installation	0 to 3	<I>

<I> Default setting is determined by drive model.

Setting 0: (Models 2A0250 to 2A0415 and 4A0208 to 4A1200)

Setting 2: (Models 2A0004 to 2A0211, 4A0002 to 4A0165, and 5A0003 to 5A0242).

#### Setting 0: IP00/Open-Chassis Enclosure

Drive operation between -10 °C and +50 °C allows 100% continuous current without derating.

## i.6 European Standards

### Setting 1: Side-by-Side Mounting

Drive operation between -10 °C and +30 °C allows 100% continuous current without derating. Operation between +30 °C and +50 °C requires output current derating.

### Setting 2: IP20/NEMA Type 1 Enclosure

Drive operation between -10 °C and +40 °C allows 100% continuous current without derating. Operation between +40 °C and +50 °C requires output current derating.

### Setting 3: External Heatsink Installation, Finless Drive

Drive operation between -10 °C and +40 °C allows 100% continuous current without derating. Operation between +40 °C and +50 °C requires output current derating.

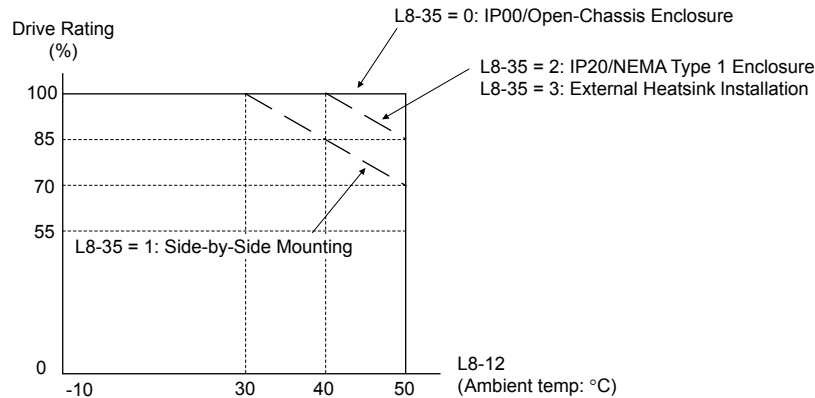

Figure i.22 Ambient Temperature and Installation Method Derating

### ◆ Altitude Derating

The drive standard ratings are valid for installation altitudes up to 1000 m. For installations from 1000 m to 3000 m, the drive rated voltage and the rated output current must be derated for 1% per 100 m.

### ◆ Dimensions, Weight, Heat Loss

#### NOTICE

Refer to the *Mechanical Installation Chapter* and the *Specifications Chapter* of the *A1000 Technical Manual SIEPC71061641* which can be found on the CD-ROM packaged with the product.



## ◆ Drive Specifications

	Item	Specification
Control Characteristics	<b>Control Method</b>	The following control methods can be set using drive parameters: <ul style="list-style-type: none"> <li>• V/f Control (V/f)</li> <li>• V/f Control with PG (V/f w/PG)</li> <li>• Open Loop Vector Control (OLV)</li> <li>• Closed Loop Vector Control (CLV)</li> <li>• Open Loop Vector Control for PM (OLV/PM)</li> <li>• Advanced Open Loop Vector Control for PM (AOLV/PM)</li> <li>• Closed Loop Vector Control for PM (CLV/PM)</li> </ul> <b>Note:</b> PM motor control modes are not available on 600 V class drives, models 5A□□□□.
	<b>Frequency Control Range</b>	0.01 to 400 Hz
	<b>Frequency Accuracy (Temperature Fluctuation)</b>	Digital input: within $\pm 0.01\%$ of the max output frequency ( $-10$ to $+40$ °C) Analog input: within $\pm 0.1\%$ of the max output frequency ( $25$ °C $\pm 10$ °C)
	<b>Frequency Setting Resolution</b>	Digital inputs: 0.01 Hz Analog inputs: 1/2048 of the maximum output frequency setting (11 bit plus sign)
	<b>Output Frequency Resolution</b>	0.001 Hz
	<b>Frequency Setting Signal</b>	Main speed frequency reference: DC $-10$ to $+10$ V (20 k $\Omega$ ), DC $0$ to $+10$ V (20 k $\Omega$ ), 4 to 20 mA (250 $\Omega$ ), 0 to 20 mA (250 $\Omega$ ) Main speed reference: Pulse train input (max. 32 kHz)
	<b>Starting Torque</b> <math>\leftrightarrow</math>	V/f, V/f w/PG: 150% at 3 Hz OLV: 200% at 0.3 Hz <math>\leftrightarrow</math> CLV, AOLV/PM, CLV/PM: 200% at 0.0 r/min <math>\leftrightarrow</math> OLV/PM: 100% at 3 Hz
	<b>Speed Control Range</b> <math>\leftrightarrow</math>	V/f, V/f w/PG: 1:40 OLV: 1:200 CLV, CLV/PM: 1:1500 OLV/PM: 1:20 AOLV/PM: 1:100
	<b>Speed Control Accuracy</b> <math>\leftrightarrow</math>	OLV: $\pm 0.2\%$ ( $25$ °C $\pm 10$ °C) CLV: $\pm 0.02\%$ ( $25$ °C $\pm 10$ °C)
	<b>Speed Response</b> <math>\leftrightarrow</math>	OLV, OLV/PM, AOLV/PM: 10 Hz ( $25$ °C $\pm 10$ °C ( $77$ °F $\pm 50$ °F)) CLV, CLV/PM: 50 Hz ( $25$ °C $\pm 10$ °C ( $77$ °F $\pm 50$ °F))
	<b>Torque Limit</b>	Parameters setting allow separate limits in four quadrants (available in OLV, CLV, AOLV/PM, CLV/PM)
	<b>Accel/Decel Time</b>	0.0 to 6000.0 s (4 selectable combinations of independent acceleration and deceleration settings)
	<b>Braking Torque</b>	Approx. 20% (approx. 125% when using braking resistor) <math>\leftrightarrow</math> <ul style="list-style-type: none"> <li>• Short-time decel torque &lt;math&gt;\leftrightarrow&lt;/math&gt; : over 100% for 0.4/ 0.75 kW motors, over 50% for 1.5 kW motors, and over 20% for 2.2 kW and above motors &lt;math&gt;\leftrightarrow&lt;/math&gt; (overexcitation braking/High Slip Braking: approx. 40%)</li> <li>• Continuous regenerative torque: approx. 20% &lt;math&gt;\leftrightarrow&lt;/math&gt; (approx. 125% with dynamic braking resistor option &lt;math&gt;\leftrightarrow&lt;/math&gt; : 10% ED, 10s)</li> </ul>
	<b>Braking Transistor</b>	Models 2A0004 to 2A0138, 4A0002 to 4A0072, and 5A0003 to 5A0052 have a built-in braking transistor.
<b>V/f Characteristics</b>	User-selected programs and V/f preset patterns possible	
<b>Main Control Functions</b>	Torque Control, Droop Control, Speed/torque Control Switching, Feed Forward Control, Zero Servo Function, Momentary Power Loss Ride-Thru, Speed Search, Overtorque/Undertorque Detection, Torque Limit, 17 Step Speed (max), Accel/decel Switch, S-curve Accel/decel, 3-wire Sequence, Auto-tuning (rotational, stationary tuning), Dwell, Cooling Fan on/off Switch, Slip Compensation, Torque Compensation, Frequency Jump, Upper/lower Limits for Frequency Reference, DC Injection Braking at Start and Stop, Overexcitation Braking, High Slip Braking, PID Control (with sleep function), Energy Saving Control, MEMOBUS/Modbus Comm. (RS-422/RS-485 max, 115.2 kbps), Fault Restart, Application Presets, DriveWorksEZ (customized function), Removable Terminal Block with Parameter Backup Function, Online Tuning, KEB, Overexcitation Deceleration, Inertia (ASR) Tuning, Overvoltage Suppression, High Frequency Injection.	

## i.6 European Standards

Item		Specification
Protection Functions	Motor Protection	Electronic thermal overload relay
	Momentary Overcurrent Protection	Drive stops when output current exceeds 200% of Heavy Duty Rating
	Overload Protection	Drive stops after 60 s at 150% of rated Heavy Duty output current <6>
	Overvoltage Protection	200 V class: Stops when DC bus voltage exceeds approx. 410 V 400 V class: Stops when DC bus voltage exceeds approx. 820 V 600 V class: Stops when DC bus voltage exceeds approx. 1040 V
	Undervoltage Protection	200 V class: Stops when DC bus voltage falls below approx. 190 V 400 V class: Stops when DC bus voltage falls below approx. 380 V 600 V class: Stops when DC bus voltage falls below approx. 475 V
	Momentary Power Loss Ride-Thru	Immediately stop after 15 ms or longer power loss <7> . Continuous operation during power loss than 2 s (standard) <8>
	Heatsink Overheat Protection	Thermistor
	Braking Resistor Overheat Protection	Overheat input signal for braking resistor (Optional ERF-type, 3% ED)
	Stall Prevention	Stall Prevention is available during acceleration, deceleration, and during run.
	Ground Protection	Electronic circuit protection <9>
	DC Bus Charge LED	Remains lit until DC bus voltage falls below 50 V
Environment	Area of Use	Indoors
	Ambient Temperature	IP20/NEMA Type 1 enclosure: -10 °C to +40 °C (14 °F to 104 °F), IP00 enclosure: -10 °C to +50 °C (14 °F to 122 °F)
	Humidity	95 RH% or less (no condensation)
	Storage Temperature	-20 °C to +60 °C (short-term temperature during transportation)
	Altitude	Up to 1000 meters without derating, up to 3000 m with output current and voltage derating.
	Vibration/Shock	10 to 20 Hz: 9.8 m/s <sup>2</sup> <10> 20 to 55 Hz: 5.9 m/s <sup>2</sup> (2A0004 to 2A0211, 4A0002 to 4A0165, and 5A0003 to 5A0099) 2.0 m/s <sup>2</sup> (2A0250 to 2A0415, 4A0208 to 4A1200, and 5A0125 to 5A0242)
	Standard	<ul style="list-style-type: none"> <li>UL508C</li> <li>IEC/EN61800-3, IEC/EN61800-5-1</li> <li>Two Safe Disable inputs and one EDM output according to ISO/EN13849-1 Cat. 3 PLd, IEC/EN61508 SIL2</li> <li>CSA &lt;11&gt;</li> </ul>
	Protection Design	IP00/Open Type enclosure, IP20/NEMA Type 1 enclosure <12>

- <1> Select control modes in accordance with drive capacity.
- <2> The accuracy of these values depends on motor characteristics, ambient conditions, and drive settings. Specifications may vary with different motors and with changing motor temperature. Contact Yaskawa for consultation.
- <3> Disable Stall Prevention during deceleration (L3-04 = 0) when using a regenerative converter, a regenerative unit, a braking resistor or the Braking Resistor Unit. The default setting for the Stall Prevention function will interfere with the braking resistor.
- <4> Instantaneous average deceleration torque refers to the torque required to decelerate the motor (uncoupled from the load) from the rated motor speed down to zero in the shortest time.
- <5> Actual specifications may vary depending on motor characteristics.
- <6> Overload protection may be triggered when operating with 150% of the rated output current if the output frequency is less than 6 Hz.
- <7> May be shorter due to load conditions and motor speed.
- <8> A separate Momentary Power Loss Ride-Thru Unit is required for models 2A0004 to 2A0056 and 4A0002 to 4A0031 if the application needs to continue running for up to 2 seconds during a momentary power loss.
- <9> Ground protection cannot be provided when the impedance of the ground fault path is too low, or when the drive is powered up while a ground fault is present at the output.
- <10> Models 4A0930 and 4A1200 are rated at 5.9 m/s<sup>2</sup>.
- <11> Terminals H1, H2, DM+, and DM- on 600 V class models are designed to the functionality, but are not certified to Insulation coordination: class 1.
- <12> Removing the top protective cover or bottom conduit bracket from an IP20/NEMA Type 1 enclosure drive voids NEMA Type 1 protection while maintaining IP20 conformity. This is applicable to models 2A0004 to 2A0211, 4A0002 to 4A0165, and 5A0003 to 5A0242.

## ◆ Parameter Setting Reference

Use the Verify Menu to determine which parameters have been changed from their original default settings



below the parameter number indicates that the parameter setting can be changed during run.

Parameter names in **bold face type** are included in the Setup Group of parameters, which can be set by A1-06 = 0.

No.	Name	User Setting	No.	Name	User Setting
A1-00 	Language Selection		b3-07	Output Current 2 during Speed Search (Speed Estimation Type)	
A1-01 	Access Level Selection		b3-08	Current Control Gain during Speed Search (Speed Estimation Type)	
A1-02	<b>Control Method Selection</b>		b3-10	Speed Search Detection Compensation Gain	
A1-03	Initialize Parameters		b3-12	Minimum Current Detection Level during Speed Search	
A1-04	Password		b3-14	Bi-Directional Speed Search Selection	
A1-05	Password Setting		b3-17	Speed Search Restart Current Level	
A1-06	Application Preset		b3-18	Speed Search Restart Detection Time	
A1-07	DriveWorksEZ Function Selection		b3-19	Number of Speed Search Restarts	
A2-01 to A2-32	User Parameters, 1 to 32		b3-24	Speed Search Method Selection	
A2-33	User Parameter Automatic Selection		b3-25	Speed Search Wait Time	
b1-01	<b>Frequency Reference Selection 1</b>		b3-26	Direction Determining Level	
b1-02	<b>Run Command Selection 1</b>		b3-27	Start Speed Search Select	
b1-03	<b>Stopping Method Selection</b>		b3-29 </>	Speed Search Induced Voltage Level	
b1-04	Reverse Operation Selection		b3-33	Speed Search Selection when Run Command is Given during Uv	
b1-05	Action Selection below Minimum Output Frequency		b4-01	Timer Function On-Delay Time	
b1-06	Digital Input Reading		b4-02	Timer Function Off-Delay Time	
b1-07	LOCAL/REMOTE Run Selection		b4-03 </>	H2-01 ON Delay Time	
b1-08	Run Command Selection while in Programming Mode		b4-04 </>	H2-01 OFF Delay Time	
b1-14	Phase Order Selection		b4-05 </>	H2-02 ON Delay Time	
b1-15	Frequency Reference Selection 2		b4-06 </>	H2-03 OFF Delay Time	
b1-16	Run Command Selection 2		b4-07 </>	H2-03 ON Delay Time	
b1-17	Run Command at Power Up		b4-08 </>	H2-03 OFF Delay Time	
b1-21 </>	Start Condition Selection at Closed Loop Vector Control		b5-01	PID Function Setting	
b2-01	DC Injection Braking Start Frequency		b5-02 	Proportional Gain Setting (P)	
b2-02	DC Injection Braking Current		b5-03 	Integral Time Setting (I)	
b2-03	DC Injection Braking Time at Start		b5-04 	Integral Limit Setting	
b2-04	DC Injection Braking Time at Stop		b5-05 	Derivative Time (D)	
b2-08	Magnetic Flux Compensation Value		b5-06 	PID Output Limit	
b2-12	Short Circuit Brake Time at Start		b5-07 	PID Offset Adjustment	
b2-13	Short Circuit Brake Time at Stop		b5-08 	PID Primary Delay Time Constant	
b2-18	Short Circuit Braking Current				
b3-01	Speed Search Selection at Start				
b3-02	Speed Search Deactivation Current				
b3-03	Speed Search Deceleration Time				
b3-04	V/f Gain during Speed Search				
b3-05	Speed Search Delay Time				
b3-06	Output Current 1 during Speed Search				







## i.6 European Standards

No.	Name	User Setting	No.	Name	User Setting
b5-09	PID Output Level Selection		C1-02	<b>Deceleration Time 1</b>	
b5-10	PID Output Gain Setting		 C1-03		Acceleration Time 2
b5-11	PID Output Reverse Selection		C1-04	Deceleration Time 2	
b5-12	PID Feedback Loss Detection Selection		 C1-05	Acceleration Time 3 (Motor 2 Accel Time 1)	
b5-13	PID Feedback Loss Detection Level		C1-06	Deceleration Time 3 (Motor 2 Decel Time 1)	
b5-14	PID Feedback Loss Detection Time		 C1-07	Acceleration Time 4 (Motor 2 Accel Time 2)	
b5-15	PID Sleep Function Start Level		C1-08	Deceleration Time 4 (Motor 2 Decel Time 2)	
b5-16	PID Sleep Delay Time		 C1-09	Fast-Stop Time	
b5-17	PID Accel/Decel Time		 C1-10	Accel/Decel Time Setting Units	
b5-18	PID Setpoint Selection		C1-11	Accel/Decel Time Switching Frequency	
b5-19	PID Setpoint Value		C2-01	S-Curve Characteristic at Accel Start	
b5-20	PID Setpoint Scaling		C2-02	S-Curve Characteristic at Accel End	
 b5-34	PID Output Lower Limit		C2-03	S-Curve Characteristic at Decel Start	
 b5-35	PID Input Limit		C2-04	S-Curve Characteristic at Decel End	
b5-36	PID Feedback High Detection Level		 C3-01	Slip Compensation Gain	
b5-37	PID Feedback High Detection Time		 C3-02	Slip Compensation Primary Delay Time	
b5-38	PID Setpoint User Display		C3-03	Slip Compensation Limit	
b5-39	PID Setpoint Display Digits		C3-04	Slip Compensation Selection during Regeneration	
b5-40	Frequency Reference Monitor Content during PID		C3-05	Output Voltage Limit Operation Selection	
b5-47	PID Output Reverse Selection 2		 C3-21	Motor 2 Slip Compensation Gain	
b6-01	Dwell Reference at Start		 C3-22	Motor 2 Slip Compensation Primary Delay Time	
b6-02	Dwell Time at Start		C3-23	Motor 2 Slip Compensation Limit	
b6-03	Dwell Reference at Stop		C3-24	Motor 2 Slip Compensation Selection during Regeneration	
b6-04	Dwell Time at Stop		 C4-01	Torque Compensation Gain	
 b7-01	Droop Control Gain		 C4-02	Torque Compensation Primary Delay Time	
 b7-02	Droop Control Delay Time		C4-03	Torque Compensation at Forward Start	
b7-03	Droop Control Limit Selection		C4-04	Torque Compensation at Reverse Start	
b8-01	Energy Saving Control Selection		C4-05	Torque Compensation Time Constant	
 b8-02	Energy Saving Gain		C4-06	Torque Compensation Primary Delay Time 2	
 b8-03	Energy Saving Control Filter Time Constant		 C4-07	Motor 2 Torque Compensation Gain	
b8-04	Energy Saving Coefficient Value				
b8-05	Power Detection Filter Time				
b8-06	Search Operation Voltage Limit				
b8-16	Energy Saving Parameter (Ki) for PM Motors				
b8-17	Energy Saving Parameter (Kt) for PM Motors				
b9-01	Zero Servo Gain				
b9-02	Zero Servo Completion Width				
 C1-01	<b>Acceleration Time 1</b>				

No.	Name	User Setting	No.	Name	User Setting
 C5-01	ASR Proportional Gain 1		 d1-05	Frequency Reference 5	
 C5-02	ASR Integral Time 1		 d1-06	Frequency Reference 6	
 C5-03	ASR Proportional Gain 2		 d1-07	Frequency Reference 7	
 C5-04	ASR Integral Time 2		 d1-08	Frequency Reference 8	
C5-05	ASR Limit		 d1-09	Frequency Reference 9	
C5-06	ASR Primary Delay Time Constant		 d1-10	Frequency Reference 10	
C5-07	ASR Gain Switching Frequency		 d1-11	Frequency Reference 11	
C5-08	ASR Integral Limit		 d1-12	Frequency Reference 12	
C5-12	Integral Operation during Accel/Decel		 d1-13	Frequency Reference 13	
C5-17	Motor Inertia		 d1-14	Frequency Reference 14	
C5-18	Load Inertia Ratio		 d1-15	Frequency Reference 15	
 C5-21	Motor 2 ASR Proportional Gain 1		 d1-16	Frequency Reference 16	
 C5-22	Motor 2 ASR Integral Time 1		 d1-17	<b>Jog Frequency Reference</b>	
 C5-23	Motor 2 ASR Proportional Gain 2		d2-01	Frequency Reference Upper Limit	
 C5-24	Motor 2 ASR Integral Time 2		d2-02	Frequency Reference Lower Limit	
C5-25	Motor 2 ASR Limit		d2-03	Master Speed Reference Lower Limit	
C5-26	Motor 2 ASR Primary Delay Time Constant		d3-01	Jump Frequency 1	
C5-27	Motor 2 ASR Gain Switching Frequency		d3-02	Jump Frequency 2	
C5-28	Motor 2 ASR Integral Limit		d3-03	Jump Frequency 3	
C5-32	Integral Operation during Accel/Decel for Motor 2		d3-04	Jump Frequency Width	
C5-37	Motor 2 Inertia		d4-01	Frequency Reference Hold Function Selection	
C5-38	Motor 2 Load Inertia Ratio		 d4-03	Frequency Reference Bias Step (Up/Down 2)	
C5-39 < >	ASR Primary Delay Time Constant 2		 d4-04	Frequency Reference Bias Accel/Decel (Up/Down 2)	
C6-01	<b>Drive Duty Selection</b>		 d4-05	Frequency Reference Bias Operation Mode Selection (Up/Down 2)	
C6-02	<b>Carrier Frequency Selection</b>		d4-06	Frequency Reference Bias (Up/Down 2)	
C6-03	Carrier Frequency Upper Limit		 d4-07	Analog Frequency Reference Fluctuation Limit (Up/Down 2)	
C6-04	Carrier Frequency Lower Limit		 d4-08	Frequency Reference Bias Upper Limit (Up/Down 2)	
C6-05	Carrier Frequency Proportional Gain		 d4-09	Frequency Reference Bias Lower Limit (Up/Down 2)	
C6-09 < >	Carrier Frequency during Rotational Auto-Tuning				
 d1-01	<b>Frequency Reference 1</b>				
 d1-02	<b>Frequency Reference 2</b>				
 d1-03	<b>Frequency Reference 3</b>				
 d1-04	<b>Frequency Reference 4</b>				

## i.6 European Standards

No.	Name	User Setting	No.	Name	User Setting
d4-10	Up/Down Frequency Reference Limit Selection		E3-07	Motor 2 Mid Output Frequency	
d5-01	Torque Control Selection		E3-08	Motor 2 Mid Output Frequency Voltage	
d5-02	Torque Reference Delay Time		E3-09	Motor 2 Minimum Output Frequency	
d5-03	Speed Limit Selection		E3-10	Motor 2 Minimum Output Frequency Voltage	
d5-04	Speed Limit		E3-11	Motor 2 Mid Output Frequency 2	
d5-05	Speed Limit Bias		E3-12	Motor 2 Mid Output Frequency Voltage 2	
d5-06	Speed/Torque Control Switchover Time		E3-13	<b>Motor 2 Base Voltage</b>	
d5-08	Unidirectional Speed Limit Bias		E4-01	Motor 2 Rated Current	
d6-01	Field Weakening Level		E4-02	Motor 2 Rated Slip	
d6-02	Field Weakening Frequency Limit		E4-03	Motor 2 Rated No-Load Current	
d6-03	Field Forcing Selection		E4-04	Motor 2 Motor Poles	
d6-06	Field Forcing Limit		E4-05	Motor 2 Line-to-Line Resistance	
d7-01 	Offset Frequency 1		E4-06	Motor 2 Leakage Inductance	
d7-02 	Offset Frequency 2		E4-07	Motor 2 Motor Iron-Core Saturation Coefficient 1	
d7-03 	Offset Frequency 3		E4-08	Motor 2 Motor Iron-Core Saturation Coefficient 2	
E1-01	<b>Input Voltage Setting</b>		E4-09	Motor 2 Mechanical Loss	
E1-03	V/f Pattern Selection		E4-10	Motor 2 Iron Loss	
E1-04	<b>Maximum Output Frequency</b>		E4-11	Motor 2 Rated Power	
E1-05	<b>Maximum Voltage</b>		E5-01	<b>Motor Code Selection (for PM Motors)</b>	
E1-06	<b>Base Frequency</b>		E5-02	<b>Motor Rated Power (for PM Motors)</b>	
E1-07	Middle Output Frequency		E5-03	<b>Motor Rated Current (for PM Motors)</b>	
E1-08	Middle Output Frequency Voltage		E5-04	<b>Number of Motor Poles (for PM Motors)</b>	
E1-09	<b>Minimum Output Frequency</b>		E5-05	<b>Motor Stator Resistance (for PM Motors)</b>	
E1-10	Minimum Output Frequency Voltage		E5-06	<b>Motor d-Axis Inductance (for PM Motors)</b>	
E1-11	Middle Output Frequency 2		E5-07	<b>Motor q-Axis Inductance (for PM Motors)</b>	
E1-12	Middle Output Frequency Voltage 2		E5-09	<b>Motor Induction Voltage Constant 1 (for PM Motors)</b>	
E1-13	<b>Base Voltage</b>		E5-11	Encoder Z-pulse Offset (for PM Motors)	
E2-01	<b>Motor Rated Current</b>		E5-24	<b>Motor Induction Voltage Constant 2 (for PM Motors)</b>	
E2-02	Motor Rated Slip		E5-25	Polarity Switch for Initial Polarity Estimation Timeout (for PM Motors)	
E2-03	Motor No-Load Current		F1-01	PG 1 Pulses Per Revolution	
E2-04	Number of Motor Poles		F1-02	Operation Selection at PG Open Circuit (PGo)	
E2-05	Motor Line-to-Line Resistance		F1-03	Operation Selection at Overspeed (oS)	
E2-06	Motor Leakage Inductance		F1-04	Operation Selection at Deviation	
E2-07	Motor Iron-Core Saturation Coefficient 1		F1-05	PG 1 Rotation Selection	
E2-08	Motor Iron-Core Saturation Coefficient 2		F1-06	PG 1 Division Rate for PG Pulse Monitor	
E2-09	Motor Mechanical Loss		F1-08	Overspeed Detection Level	
E2-10	Motor Iron Loss for Torque Compensation		F1-09	Overspeed Detection Delay Time	
E2-11	<b>Motor Rated Power</b>		F1-10	Excessive Speed Deviation Detection Level	
E3-01	Motor 2 Control Mode Selection		F1-11	Excessive Speed Deviation Detection Delay Time	
E3-04	Motor 2 Maximum Output Frequency		F1-12	PG 1 Gear Teeth 1	
E3-05	Motor 2 Maximum Voltage		F1-13	PG 1 Gear Teeth 2	
E3-06	Motor 2 Base Frequency		F1-14	PG Open-Circuit Detection Time	
			F1-18	dv3 Detection Selection	

No.	Name	User Setting
F1-19	dv4 Detection Selection	
F1-20	PG Option Card Disconnect Detection 1	
F1-21	PG 1 Signal Selection	
F1-30	PG Option Card Port for Motor 2 Selection	
F1-31	PG 2 Pulses Per Revolution	
F1-32	PG 2 Rotation Selection	
F1-33	PG 2 Gear Teeth 1	
F1-34	PG 2 Gear Teeth 2	
F1-35	PG 2 Division Rate for PG Pulse Monitor	
F1-36	PG Option Card Disconnect Detection 2	
F1-37	PG2 Signal Selection	
F1-50 </>	Encoder Selection	
F1-51 </>	PGoH Detection Level	
F1-52 </>	Communication Speed of Serial Encoder Selection	
F2-01	Analog Input Option Card Operation Selection	
F2-02 	Analog Input Option Card Gain	
F2-03 	Analog Input Option Card Bias	
F3-01	Digital Input Option Card Input Selection	
F3-03	Digital Input Option DI-A3 Data Length Selection	
F4-01	Terminal V1 Monitor Selection	
F4-02 	Terminal V1 Monitor Gain	
F4-03	Terminal V2 Monitor Selection	
F4-04 	Terminal V2 Monitor Gain	
F4-05 	Terminal V1 Monitor Bias	
F4-06 	Terminal V2 Monitor Bias	
F4-07	Terminal V1 Signal Level	
F4-08	Terminal V2 Signal Level	
F5-01	Terminal M1-M2 Output Selection	
F5-02	Terminal M3-M4 Output Selection	
F5-03	Terminal P1-PC Output Selection	
F5-04	Terminal P2-PC Output Selection	
F5-05	Terminal P3-PC Output Selection	
F5-06	Terminal P4-PC Output Selection	
F5-07	Terminal P5-PC Output Selection	
F5-08	Terminal P6-PC Output Selection	
F5-09	DO-A3 Output Mode Selection	
F6-01	Communications Error Operation Selection	
F6-02	External Fault from Comm. Option Detection Selection	

No.	Name	User Setting
F6-03	External Fault from Comm. Option Operation Selection	
F6-04	bUS Error Detection Time	
F6-06	Torque Reference/Torque Limit Selection from Comm. Option	
F6-07	Multi-Step Speed Enable/Disable Selection when NefRef/ComRef is Selected	
F6-08	Reset Communication Parameters	
F6-10	CC-Link Node Address	
F6-11	CC-Link Communications Speed	
F6-14	CC-Link bUS Error Auto Reset	
F6-20	MECHATROLINK-II Station Address	
F6-21	MECHATROLINK-II Frame Size	
F6-22	MECHATROLINK-II Link Speed	
F6-23	MECHATROLINK-II Monitor Selection (E)	
F6-24	MECHATROLINK-II Monitor Selection (F)	
F6-25	Operation Selection at Watchdog Timer Error (E5)	
F6-26	MECHATROLINK-II bUS Errors Detected	
F6-30	PROFIBUS-DP Node Address	
F6-31	PROFIBUS-DP Clear Mode Selection	
F6-32	PROFIBUS-DP Data Format Selection	
F6-35	CANopen Node ID Selection	
F6-36	CANopen Communication Speed	
F6-45	BACnet Node Address	
F6-46	BACnet Baud Rate	
F6-47	Rx to Tx Wait Time	
F6-48	BACnet Device Object Identifier 0	
F6-49	BACnet Device Object Identifier 1	
F6-50	DeviceNet MAC Address	
F6-51	DeviceNet Communication Speed	
F6-52	DeviceNet PCA Setting	
F6-53	DeviceNet PPA Setting	
F6-54	DeviceNet Idle Mode Fault Detection	
F6-55	DeviceNet Baud Rate Monitor	
F6-56	DeviceNet Speed Scaling	
F6-57	DeviceNet Current Scaling	
F6-58	DeviceNet Torque Scaling	
F6-59	DeviceNet Power Scaling	
F6-60	DeviceNet Voltage Scaling	
F6-61	DeviceNet Time Scaling	
F6-62	DeviceNet Heartbeat Interval	
F6-63	DeviceNet Network MAC ID	
F6-64 to F6-71	Reserved	
H1-01	Multi-Function Digital Input Terminal S1 Function Selection	

## i.6 European Standards

No.	Name	User Setting	No.	Name	User Setting
H1-02	Multi-Function Digital Input Terminal S2 Function Selection		H4-04	Multi-Function Analog Output Terminal AM Monitor Selection	
H1-03	Multi-Function Digital Input Terminal S3 Function Selection		H4-05 	<b>Multi-Function Analog Output Terminal AM Gain</b>	
H1-04	Multi-Function Digital Input Terminal S4 Function Selection		H4-06 	Multi-Function Analog Output Terminal AM Bias	
H1-05	Multi-Function Digital Input Terminal S5 Function Selection		H4-07	Multi-Function Analog Output Terminal FM Signal Level Selection	
H1-06	Multi-Function Digital Input Terminal S6 Function Selection		H4-08	Multi-Function Analog Output Terminal AM Signal Level Selection	
H1-07	Multi-Function Digital Input Terminal S7 Function Selection		H5-01	Drive Node Address	
H1-08	Multi-Function Digital Input Terminal S8 Function Selection		H5-02	Communication Speed Selection	
H2-01	Multi-Function Contact Output (terminal M1-M2)		H5-03	Communication Parity Selection	
H2-02	Multi-Function Contact Output 2 (terminal M3-M4)		H5-04	Stopping Method After Communication Error (CE)	
H2-03	Multi-Function Contact Output 3 (terminal M5-M6)		H5-05	Communication Fault Detection Selection	
H2-06	Watt Hour Output Unit Selection		H5-06	Drive Transmit Wait Time	
H2-07 	MEMOBUS Register 1 Address Select		H5-07	RTS Control Selection	
H2-08 	MEMOBUS Register 1 Bit Select		H5-09	CE Detection Time	
H2-09 	MEMOBUS Register 2 Address Select		H5-10	Unit Selection for MEMOBUS/Modbus Register 0025H	
H2-10 	MEMOBUS Register 2 Bit Select		H5-11	Communications ENTER Function Selection	
H3-01	Terminal A1 Signal Level Selection		H5-12	Run Command Method Selection	
H3-02	Terminal A1 Function Selection		H5-17 	Operation Selection when Unable to Write into EEPROM	
H3-03 	Terminal A1 Gain Setting		H5-18 	Filter Time Constant for Motor Speed Monitoring	
H3-04 	Terminal A1 Bias Setting		H6-01	Pulse Train Input Terminal RP Function Selection	
H3-05	Terminal A3 Signal Level Selection		H6-02 	Pulse Train Input Scaling	
H3-06	Terminal A3 Function Selection		H6-03 	Pulse Train Input Gain	
H3-07 	Terminal A3 Gain Setting		H6-04 	Pulse Train Input Bias	
H3-08 	Terminal A3 Bias Setting		H6-05 	Pulse Train Input Filter Time	
H3-09	Terminal A2 Signal Level Selection		H6-06 	Pulse Train Monitor Selection	
H3-10	Terminal A2 Function Selection		H6-07 	Pulse Train Monitor Scaling	
H3-11 	Terminal A2 Gain Setting		H6-08	Pulse Train Input Minimum Frequency	
H3-12 	Terminal A2 Bias Setting		L1-01	<b>Motor Overload Protection Selection</b>	
H3-13	Analog Input Filter Time Constant		L1-02	Motor Overload Protection Time	
H3-14	Analog Input Terminal Enable Selection		L1-03	Motor Overheat Alarm Operation Selection (PTC input)	
H4-01	Multi-Function Analog Output Terminal FM Monitor Selection		L1-04	Motor Overheat Fault Operation Selection (PTC input)	
H4-02 	<b>Multi-Function Analog Output Terminal FM Gain</b>		L1-05	Motor Temperature Input Filter Time (PTC input)	
H4-03 	Multi-Function Analog Output Terminal FM Bias		L1-08 	oL1 Current Level	
			L1-09 	oL1 Current Level (for Motor 2)	



No.	Name	User Setting	No.	Name	User Setting
L1-13	Continuous Electrothermal Operation Selection		L6-02	Torque Detection Level 1	
L2-01	Momentary Power Loss Operation Selection		L6-03	Torque Detection Time 1	
L2-02	Momentary Power Loss Ride-Thru Time		L6-04	Torque Detection Selection 2	
L2-03	Momentary Power Loss Minimum Baseblock Time		L6-05	Torque Detection Level 2	
L2-04	Momentary Power Loss Voltage Recovery Ramp Time		L6-06	Torque Detection Time 2	
L2-05	Undervoltage Detection Level (Uv1)		L6-08	Mechanical Weakening Detection Operation	
L2-06	KEB Deceleration Time		L6-09	Mechanical Weakening Detection Speed Level	
L2-07	KEB Acceleration Time		L6-10	Mechanical Weakening Detection Time	
L2-08	Frequency Gain at KEB Start		L6-11	Mechanical Weakening Detection Start Time	
L2-10	KEB Detection Time (Minimum KEB Time)		L7-01	Forward Torque Limit	
L2-11	DC Bus Voltage Setpoint during KEB		L7-02	Reverse Torque Limit	
L2-29	KEB Method Selection		L7-03	Forward Regenerative Torque Limit	
L3-01	Stall Prevention Selection during Acceleration		L7-04	Reverse Regenerative Torque Limit	
L3-02	Stall Prevention Level during Acceleration		L7-06	Torque Limit Integral Time Constant	
L3-03	Stall Prevention Limit during Acceleration		L7-07	Torque Limit Control Method Selection during Accel/Decel	
L3-04	<b>Stall Prevention Selection during Deceleration</b>		L7-16	Torque Limit Process at Start	
L3-05	Stall Prevention Selection during Run		L8-01 < / >	Internal Dynamic Braking Resistor Protection Selection (ERF type)	
L3-06	Stall Prevention Level during Run		L8-02	Overheat Alarm Level	
L3-11	Overvoltage Suppression Function Selection		L8-03	Overheat Pre-Alarm Operation Selection	
L3-17	Target DC Bus Voltage for Overvoltage Suppression and Stall Prevention		L8-05	Input Phase Loss Protection Selection	
L3-20	DC Bus Voltage Adjustment Gain		L8-07	Output Phase Loss Protection	
L3-21	Accel/Decel Rate Calculation Gain		L8-09	Output Ground Fault Detection Selection	
L3-22	Deceleration Time at Stall Prevention during Acceleration		L8-10	Heatsink Cooling Fan Operation Selection	
L3-23	Automatic Reduction Selection for Stall Prevention during Run		L8-11	Heatsink Cooling Fan Off Delay Time	
L3-24	Motor Acceleration Time for Inertia Calculations		L8-12	Ambient Temperature Setting	
L3-25	Load Inertia Ratio		L8-15	oL2 Characteristics Selection at Low Speeds	
L3-26	Additional DC Bus Capacitors		L8-18	Software Current Limit Selection	
L3-27	Stall Prevention Detection Time		L8-19	Frequency Reduction Rate during Overheat Pre-Alarm	
L3-34 < / >	Torque Limit Delay Time		L8-27	Overcurrent Detection Gain	
L3-35 < / >	Speed Agree Width at Intelligent Stall Prevention during Deceleration		L8-29	Current Unbalance Detection (LF2)	
L4-01	Speed Agree Detection Level		L8-32	Cooling Fan Failure Selection	
L4-02	Speed Agree Detection Width		L8-35	Installation Method Selection	
L4-03	Speed Agree Detection Level (+/-)		L8-38	Carrier Frequency Reduction Selection	
L4-04	Speed Agree Detection Width (+/-)		L8-40	Carrier Frequency Reduction Off-Delay Time	
L4-05	Frequency Reference Loss Detection Selection		L8-41	High Current Alarm Selection	
L4-06	Frequency Reference at Reference Loss		L8-55 < / >	Internal Braking Transistor Protection	
L4-07	Speed Agree Detection Selection		L8-78	Power Unit Output Phase Loss Protection	
L5-01	Number of Auto Restart Attempts		L8-93	LSo Detection Time at Low Speed	
L5-02	Auto Restart Fault Output Operation Selection		L8-94	LSo Detection Level at Low Speed	
L5-04	Fault Reset Interval Time		L8-95	Average LSo Frequency at Low Speed	
L5-05	Fault Reset Operation Selection		L9-03 < / >	Carrier Frequency Reduction Level Selection	
L6-01	Torque Detection Selection 1		n1-01	Hunting Prevention Selection	
			n1-02	Hunting Prevention Gain Setting	

## i.6 European Standards

No.	Name	User Setting	No.	Name	User Setting
n1-03	Hunting Prevention Time Constant		n8-72 </>	Speed Estimation Method Selection	
n1-05	Hunting Prevention Gain while in Reverse		n8-84	Initial Polarity Estimation Timeout Current	
n2-01	Speed Feedback Detection Control (AFR) Gain		o1-01	Drive Mode Unit Monitor Selection	
n2-02	Speed Feedback Detection Control (AFR) Time Constant 1		o1-02	User Monitor Selection After Power Up	
n2-03	Speed Feedback Detection Control (AFR) Time Constant 2		o1-03	Digital Operator Display Selection	
n3-01	High-Slip Braking Deceleration Frequency Width		o1-04	V/f Pattern Display Unit	
n3-02	High-Slip Braking Current Limit		o1-05 </>	LCD Contrast Control	
n3-03	High-Slip Braking Dwell Time at Stop		o1-10	User-Set Display Units Maximum Value	
n3-04	High-Slip Braking Overload Time		o1-11	User-Set Display Units Decimal Display	
n3-13	Overexcitation Deceleration Gain		o2-01	LO/RE Key Function Selection	
n3-14	High Frequency Injection during Overexcitation Deceleration		o2-02	STOP Key Function Selection	
n3-21	High-Slip Suppression Current Level		o2-03	User Parameter Default Value	
n3-23	Overexcitation Operation Selection		o2-04	Drive Model Selection	
n5-01	Feed Forward Control Selection		o2-05	Frequency Reference Setting Method Selection	
n5-02	Motor Acceleration Time		o2-06	Operation Selection when Digital Operator is Disconnected	
n5-03	Feed Forward Control Gain		o2-07	Motor Direction at Power Up when Using Operator	
n6-01	Online Tuning Selection		o2-19 </>	Selection of Parameter Write during Uv	
n6-05	Online Tuning Gain		o3-01	Copy Function Selection	
n8-01	Initial Rotor Position Estimation Current		o3-02	Copy Allowed Selection	
n8-02	Pole Attraction Current		o4-01	Cumulative Operation Time Setting	
n8-11 </>	Induction Voltage Estimation Gain 2		o4-02	Cumulative Operation Time Selection	
n8-14 </>	Polarity Compensation Gain 3		o4-03	Cooling Fan Maintenance Operation Time Setting	
n8-15 </>	Polarity Compensation Gain 4		o4-05	Capacitor Maintenance Setting	
n8-21 </>	Motor Ke Gain		o4-07	DC Bus Pre-charge Relay Maintenance Setting	
n8-35	Initial Rotor Position Detection Selection		o4-09	IGBT Maintenance Setting	
n8-36 </>	High Frequency Injection Level		o4-11	U2, U3 Initialize Selection	
n8-37 </>	High Frequency Injection Amplitude		o4-12	kWh Monitor Initialization	
n8-39 </>	Low Pass Filter Cutoff Frequency for High Frequency Injection		o4-13	Number of Run Commands Counter Initialization	
n8-45	Speed Feedback Detection Control Gain (for PM Motors)		q1-01 to q6-07	DriveWorksEZ Parameters	
n8-47	Pull-In Current Compensation Time Constant (for PM Motors)		r1-01 to r1-40	DWEZ Connection Parameter 1 to 20 (upper/lower)	
n8-48	Pull-In Current (for PM Motors)		T1-00	Motor 1/Motor 2 Selection	
n8-49	d-Axis Current for High Efficiency Control (for PM Motors)		T1-01	Auto-Tuning Mode Selection	
n8-51	Acceleration/Deceleration Pull-In Current (for PM Motors)		T1-02	Motor Rated Power	
n8-54	Voltage Error Compensation Time Constant		T1-03	Motor Rated Voltage	
n8-55	Load Inertia		T1-04	Motor Rated Current	
n8-57	High Frequency Injection		T1-05	Motor Base Frequency	
n8-62	Output Voltage Limit (for PM Motors)		T1-06	Number of Motor Poles	
n8-65	Speed Feedback Detection Control Gain during ov Suppression		T1-07	Motor Base Speed	
n8-69	Speed Calculation Gain		T1-08	PG Number of Pulses Per Revolution	
			T1-09	Motor No-Load Current (Stationary Auto-Tuning)	

No.	Name	User Setting
T1-10	Motor Rated Slip (Stationary Auto-Tuning)	
T1-11	Motor Iron Loss	
T2-01 <1>	PM Motor Auto-Tuning Mode Selection	
T2-02	PM Motor Code Selection	
T2-03	PM Motor Type	
T2-04	PM Motor Rated Power	
T2-05	PM Motor Rated Voltage	
T2-06	PM Motor Rated Current	
T2-07	PM Motor Base Frequency	
T2-08	Number of PM Motor Poles	
T2-09	PM Motor Base Speed	
T2-10	PM Motor Stator Resistance	

No.	Name	User Setting
T2-11	PM Motor d-Axis Inductance	
T2-12	PM Motor q-Axis Inductance	
T2-13	Induced Voltage Constant Unit Selection	
T2-14	PM Motor Induced Voltage Constant	
T2-15	Pull-In Current Level for PM Motor Tuning	
T2-16	PG Number of Pulses Per Revolution for PM Motor Tuning	
T2-17	Encoder Z Pulse Offset	
T3-01	Test Signal Frequency	
T3-02	Test Signal Amplitude	
T3-03	Motor Inertia	
T3-04	System Response Frequency	

<1> Not available in models 4A0930 and 4A1200.

<2> Parameter setting cannot be changed while the drive is operating the motor in models 4A0930 and 4A1200.

# i.7 Revision History

The revision dates and the numbers of the revised manuals appear on the bottom of the back cover.

Example:

MANUAL NO. SIEP C710616 45B

Published in U.S.A. September 2012 11-5  1

└─ Date of publication

└─ Date of original publication

└─ Revision number

Date of Publication	Revision Number	Section(s)	Revised Content
June 2013	1	Various	Table i.1, Figure i.9, Section: Drive Short Circuit Rating (pg. 50)
May 2013	-	-	First Edition



# YASKAWA AC Drive A1000

## High Performance Vector Control Drive

### Safety Precautions

---

#### **YASKAWA AMERICA, INC.**

2121 Norman Drive South, Waukegan, IL 60085, U.S.A.  
Phone: (800) YASKAWA (927-5292) or 1-847-887-7000 Fax: 1-847-887-7310  
<http://www.yaskawa.com>

#### **DRIVE CENTER (INVERTER PLANT)**

2-13-1, Nishimiyaichi, Yukuhashi, Fukuoka, 824-8511, Japan  
Phone: 81-930-25-3844 Fax: 81-930-25-4369  
<http://www.yaskawa.co.jp>

#### **YASKAWA ELECTRIC CORPORATION**

New Pier Takeshiba South Tower, 1-16-1, Kaigan, Minatoku, Tokyo, 105-6891, Japan  
Phone: 81-3-5402-4502 Fax: 81-3-5402-4580  
<http://www.yaskawa.co.jp>

#### **YASKAWA ELÉTRICO DO BRASIL LTDA.**

Avenda Fagundes Filho, 620 Bairro Saude, São Paulo, SP04304-000, Brasil  
Phone: 55-11-3585-1100 Fax: 55-11-5581-8795  
<http://www.yaskawa.com.br>

#### **YASKAWA EUROPE GmbH**

Hauptstrasse 185, 65760 Eschborn, Germany  
Phone: 49-6196-569-300 Fax: 49-6196-569-398  
<http://www.yaskawa.eu.com>

#### **YASKAWA ELECTRIC UK LTD.**

1 Hunt Hill Orchardton Woods, Cumbernauld, G68 9LF, United Kingdom  
Phone: 44-1236-735000 Fax: 44-1236-458182  
<http://www.yaskawa.co.uk>

#### **YASKAWA ELECTRIC KOREA CORPORATION**

7F, Doore Bldg. 24, Yeoido-dong, Yeongdungpo-gu, Seoul, 150-877, Korea  
Phone: 82-2-784-7844 Fax: 82-2-784-8495  
<http://www.yaskawa.co.kr>

#### **YASKAWA ELECTRIC (SINGAPORE) PTE. LTD.**

151 Lorong Chuan, #04-01, New Tech Park, 556741, Singapore  
Phone: 65-6282-3003 Fax: 65-6289-3003  
<http://www.yaskawa.com.sg>

#### **YASKAWA ELECTRIC (SHANGHAI) CO., LTD.**

No. 18 Xizang Zhong Road, 17F, Harbour Ring Plaza, Shanghai, 200001, China  
Phone: 86-21-5385-2200 Fax: 86-21-5385-3299  
<http://www.yaskawa.com.cn>

#### **YASKAWA ELECTRIC (SHANGHAI) CO., LTD. BEIJING OFFICE**

Room 1011, Tower W3 Oriental Plaza, No. 1 East Chang An Ave.,  
Dong Cheng District, Beijing, 100738, China  
Phone: 86-10-8518-4086 Fax: 86-10-8518-4082

#### **YASKAWA ELECTRIC TAIWAN CORPORATION**

9F, 16, Nanking E. Rd., Sec. 3, Taipei, 104, Taiwan  
Phone: 886-2-2502-5003 Fax: 886-2-2505-1280



YASKAWA AMERICA, INC.

In the event that the end user of this product is to be the military and said product is to be employed in any weapons systems or the manufacture thereof, the export will fall under the relevant regulations as stipulated in the Foreign Exchange and Foreign Trade Regulations. Therefore, be sure to follow all procedures and submit all relevant documentation according to any and all rules, regulations and laws that may apply.

Specifications are subject to change without notice for ongoing product modifications and improvements.

© 2013 YASKAWA AMERICA, INC. All rights reserved.



MANUAL NO. TOEP YAIA1U 01A

Published in U.S.A. June 2013 13-5 -0