

YASKAWA

FP605

ENCLOSED BYPASS INSTALLATION & STARTUP

AC DRIVE BYPASS FOR FAN & PUMP
APPLICATIONS

CATALOG CODE:

F6Bxxxxx

CAPACITIES:

208 V: 1 to 100 HP

240 V: 1 to 100 HP

480 V: 1 to 250 HP

PDF

yaskawa.com/TOEPYAIF6B01



DOCUMENT NUMBER: TOEPYAIF6B01

This Page Intentionally Blank

Table of Contents

i. Preface and General Precautions	7
Definitions	7
Product Description	7
Glossary	7
About Registered Trademarks	8
Using the Product Safely	8
Explanation of Signal Words	8
General Safety	8
Warning Labels	9
Cybersecurity	10
Warranty Information	11
Exclusion of Liability	11
1. Receiving	12
Section Safety	12
Catalog Code and Nameplate Check	12
Enclosed Bypass Nameplate	12
Drive Nameplate	13
How to Read Enclosed Bypass Catalog Codes	13
2. Mechanical Installation	15
Section Safety	16
Installation Environment	16
Enclosed Bypass Installation Position and Clearances	17
Bypass Components	18
Bypass Component Names	19
Enclosed Bypass Component Names	19
Moving the Bypass	21
Using the Mounting Rails to Move the Bypass	21
Removing/Reattaching Covers	22
Opening/Closing the Bypass Door Using Procedure 1	22
Removing/Reattaching the Drive Cover Using Procedure A	24
Removing/Reattaching the Cover Using Procedure B	25
3. Electrical Installation	28
Section Safety	28
Wiring Diagrams	29
Main Circuit Wiring	33

Enclosed Bypass Input and Output Power Wiring Connections	33
Factory Recommended Branch Circuit Protection	34
Wire Selection	34
Main Circuit Terminal and Motor Wiring	38
Protection of Main Circuit Terminals	39
Main Circuit Terminal Wiring Procedure	39
Enclosed Bypass Main Circuit Terminal Block Wiring Procedure	40
Bypass Controller	41
Wiring the Bypass Control Circuit Terminal	46
Drive Control Circuit	47
Wiring the Drive Control Circuit Terminal	54
Control I/O Connections	55
Set Input Signals for MFAI Terminals A1 to A3	55
Set Output Signals for MFAO Terminals FM, AM	56
Connect the Bypass to a PC	56
Motor Application Precautions	57
Precautions for Existing Standard Motors	57
Precautions for Specialized Motors	58
Notes on the Power Transmission Mechanism	58
4. Startup Procedure and Test Run	58
Section Safety	58
Keypad: Names and Functions	59
LCD Display	60
AUTO LED and HAND LED Indications	61
Keypad Mode and Menu Displays	63
Start-up, Test Operation, and Rotation Check	64
Items to Check before You Energize the Bypass	64
Bypass Start-Up Procedure	65
Test Run and Rotation Check	66
Auto-Tuning	69
Auto-Tuning for Induction Motors	69
Precautions before Auto-Tuning	69
Fine Tuning during Test Runs (Adjust the Control Function)	70
V/f Control	71
5. Troubleshooting	71
Section Safety	71
Types of Faults, Minor Faults, Alarms, and Errors	72
Faults, Minor Faults, Alarms, and Error Codes Listed Alphabetically	73
Faults, Minor Faults, Alarms, and Error Codes Listed by Decimal Value for Use with BACnet/Modbus	80
Faults	85
Minor Faults/Alarms	99
Parameter Setting Errors	108
Auto-Tuning Errors	111
Backup Function Operating Mode Display and Errors	113
Bypass Status Messages	114
Diagnosing and Resetting Faults	115

Fault and Power Loss Occur at the Same Time	115
Fault Occurs Without Power Loss	115
Fault Reset	115
6. Specifications	116
Section Safety	116
208 V Enclosed Model Specifications	116
240 V Enclosed Model Specifications	117
480 V Enclosed Model Specifications	119
Common Bypass Specifications	121
Drive Watt Loss	123
Peripheral Devices and Options	124
Bypass Communication Options	124
Option Installation Procedure	125
Periodic Inspection and Maintenance	128
7. Parameter List	128
How to Read the Parameter List	128
Terms that Identify Parameters	128
A: Initialization Parameters	129
b: Application	131
C: Tuning	137
d: Reference Settings	138
E: Motor Parameters	140
F: Options	141
H: Terminal Functions	147
L: Protection Functions	160
n: Special Adjustment	165
o: Keypad-Related Settings	166
S: Special Applications	172
Y: Application Features	177
Z: Bypass Parameters	183
U: Monitors	188
8. Network Communications	201
Section Safety	201
Fieldbus Network Support	201
BACnet Communications	201
Configure Master/Slave	201
Communication Specifications	202
Communication with the Controller	202
Bypass Operations by Serial Communications	204
BACnet Objects Supported	204
Accessing Drive Parameters and the Enter Command	215
Self-Diagnostics	216
BACnet Protocol Implementation Conformance Statement	217
Other Embedded Communication Protocols	219
9. Standards Compliance	219

Section Safety	220
UL Standards	221
Area of Use	221
Seismic Standards	221
IBC/HCAI Seismic Mounting Requirements for FP605 Bypass	222
10. Disposal	224
Section Safety	224
Disposal Instructions	224
WEEE Directive	224
Index	225
Revision History	229

Preface and General Precautions

This chapter gives information about important safety precautions for the use of this product. Failure to obey these precautions can cause serious injury or death, or damage to the product or related devices and systems. Yaskawa must not be held responsible for any injury or equipment damage as a result of the failure to observe these precautions and instructions.

◆ Definitions

These instructions contain the information necessary to use the product correctly. Read and understand the safety information and precautions before you start to use the product.

■ Product Description

The FP605 bypass provides a way to bypass the drive and allow the motor to operate directly from the AC line at full speed. It incorporates an AC drive and a two or three-contactor bypass arrangement in a single UL listed enclosure. The two electrically-interlocked IEC-rated contactors isolate the drive from the load when operating in Bypass Mode.

Control logic provides industry standard Hand/Off/Auto functions, BAS Interlock, and safety circuit interlocks in both Drive and Bypass operating modes.

Bypass components include a fused 120 Vac control circuit transformer, an input disconnect, motor overload, DC link choke, EMC filter, and an HOA keypad with LCD display.

The FP605 drive, a component of the bypass package, is a pulse width modulated drive for three-phase AC induction motors. The drive is a variable torque AC drive, designed specifically for fan and pump applications.

The bypass has embedded communications for the popular building automation protocols, BACnet/MSTP, Metasys N2, APOGEE FLN P1, and Modbus®.

The LCD keypad is equipped with Hand/Off/Auto functions. Optional DriveWizard software allows upload/download, as well as graphing and monitoring of drive parameters from a PC for ease of drive management.

Built-in PI control eliminates the need for closed loop output signals from a building automation system. It includes feedback display, inverse, square root and differential control functions, and maintains setpoint for closed loop control of fans and pumps for pressure, flow, or temperature regulation. There is also an additional independent PI control for external devices.

■ Glossary

Phrase	Definition
Bypass	YASKAWA AC Drive Bypass FP605
Drive	YASKAWA AC Drive FP605
MFAI	Multi-Function Analog Input
MFAO	Multi-Function Analog Output
MFDI	Multi-Function Digital Input
MFDO	Multi-Function Digital Output
V/f	V/f Control

■ About Registered Trademarks

- APOGEE FLN is a registered trademark of Siemens Building Technologies, Inc.
- APOGEE Anywhere is a trademark of Siemens Building Technologies, Inc.
- BACnet is a trademark of the American Society of Heating, Refrigerating, and Air-Conditioning Engineers (ASHRAE).
- EtherNet/IP is a registered trademark of Open DeviceNet Vendor Association, Inc. (ODVA).
- LonWorks and LonTalk are registered trademarks of Echelon Corporation.
- Metasys N2 is a trademark of Johnson Controls, Inc.
- Modbus is a registered trademark of Schneider Electric SA.
- PROFINET is a registered trademark of PROFIBUS International.
- Other company names and product names in this document are trademarks or registered trademarks of the respective companies.

◆ Using the Product Safely

■ Explanation of Signal Words

⚠ WARNING *Read and understand this manual before you install, operate, or do maintenance on the drive. Install the drive as specified by this manual and local codes. The symbols in this section identify safety messages in this manual. If you do not obey these safety messages, the hazards can cause serious injury, death, or damage to the products and related equipment and systems.*

These identifier words categorize and emphasize important safety precautions in these instructions.

⚠ DANGER *This signal word identifies a hazard that will cause serious injury or death if you do not prevent it.*

⚠ WARNING *This signal word identifies a hazard that can cause death or serious injuries if you do not prevent it.*

⚠ CAUTION *Identifies a hazardous situation, which, if not avoided, can cause minor or moderate injury.*

NOTICE *This signal word identifies a property damage message that is not related to personal injury.*

■ General Safety

General Precautions
<ul style="list-style-type: none">• Some figures in the instructions include options and bypasses without covers or safety shields to more clearly show the inside of the bypass. Replace covers and shields before operation. Use options and bypasses only as specified by the instructions.• The figures in this manual are examples only. All figures do not apply to all products included in this manual.• Yaskawa can change the products, specifications, and content of the instructions without notice to make the product and/or the instructions better.• If you damage or lose these instructions, contact a Yaskawa representative or the nearest Yaskawa sales office on the rear cover of the manual, and tell them the document number to order new copies.

⚠ DANGER *Do not ignore the safety messages in this manual. If you ignore the safety messages in this manual, it will cause serious injury or death. The manufacturer is not responsible for injuries or damage to equipment.*

⚠ DANGER *Electrical Shock Hazard. Do not examine, connect, or disconnect wiring on an energized bypass. Before servicing, disconnect all power to the equipment and wait for the time specified on the warning label at a minimum. The internal capacitor stays charged after the bypass is de-energized. The charge indicator LED extinguishes when the DC bus voltage decreases below 50 VDC. When all indicators are OFF, remove the covers before measuring for dangerous voltages to make sure that the bypass is safe. If you do work on the bypass when it is energized, it will cause serious injury or death from electrical shock.*

⚠ WARNING *Arc Flash Hazard. Obey local codes and Arc Flash safety requirements contained in the Standard for Electrical Safety in the Workplace NFPA 70E (2009 Edition or later) and the Workplace Electrical Safety, Canadian Standards Association (CSA) Z462-12. Obey safe work procedures and use applicable personal protective equipment (PPE). If you do not obey these requirements and procedures, it can cause serious injury or death.*

⚠ WARNING *Crush Hazard. Test the system to make sure that the bypass operates safely after you wire the bypass and set parameters. If you do not test the system, it can cause damage to equipment or serious injury or death.*

⚠ WARNING *Sudden Movement Hazard. Before you do a test run, make sure that the setting values for virtual input and output function parameters are correct. Virtual input and output functions can have different default settings and operation than wired input and output functions. Incorrect function settings can cause serious injury or death.*

⚠ WARNING *Sudden Movement Hazard. Remove all personnel and objects from the area around the bypass, motor, and machine and attach covers, couplings, shaft keys, and machine loads before you energize the bypass. If personnel are too close or if there are missing parts, it can cause serious injury or death.*

⚠ WARNING *Electrical Shock Hazard. Do not modify the bypass body, drive body, bypass circuitry, or drive circuitry. Modifications to bypass and drive body and circuitry can cause serious injury or death, will cause damage to the bypass and drive, and will void the warranty. Yaskawa is not responsible for modifications of the product made by the user.*

⚠ WARNING *Electrical Shock Hazard. Only let approved personnel install, wire, maintain, examine, replace parts, and repair the bypass. If personnel are not approved, it can cause serious injury or death.*

⚠ WARNING *Electrical Shock Hazard. Do not remove covers or touch circuit boards while the bypass is energized. If you touch the internal components of an energized bypass, it can cause serious injury or death.*

⚠ WARNING *Electrical Shock Hazard. After the bypass blows a fuse or trips a GFCI, do not immediately energize the bypass or operate peripheral devices. Wait for the time specified on the warning label at a minimum and make sure that all indicators are OFF. Then check the wiring and peripheral device ratings to find the cause of the problem. If you do not know the cause of the problem, contact Yaskawa before you energize the bypass or peripheral devices. If you do not fix the problem before you operate the bypass or peripheral devices, it can cause serious injury or death.*

⚠ WARNING *Damage to Equipment. Do not apply incorrect voltage to the main circuit of the bypass. Operate the bypass in the specified range of the input voltage on the nameplate. Voltages that are higher than the permitted nameplate tolerance can cause damage to the bypass.*

⚠ WARNING *Fire Hazard. Install sufficient branch circuit short circuit protection as specified by applicable codes and this manual. The bypass is suitable for circuits that supply not more than 100,000 RMS symmetrical amperes, 240 Vac maximum (208/240 V), 480 Vac maximum (480 V). Incorrect branch circuit short circuit protection can cause serious injury or death.*

⚠ CAUTION *Crush Hazard. Tighten terminal cover screws and hold the case safely when you move the bypass. If the bypass or covers fall, it can cause moderate injury.*

NOTICE *Use an inverter-duty motor with reinforced insulation and windings applicable for use with an AC drive. If the motor does not have the correct insulation, it can cause a short circuit or ground fault from insulation deterioration.*

NOTICE *Damage to Equipment. When you touch the bypass, drive, and circuit boards, make sure that you observe correct electrostatic discharge (ESD) procedures. If you do not follow procedures, it can cause ESD damage to the drive and bypass circuitry.*

NOTICE *Damage to Equipment. Do not do a withstand voltage test or use a megohmmeter or megger insulation tester on the bypass. These tests can cause damage to the bypass.*

NOTICE *Do not operate a bypass or connected equipment that has damaged or missing parts. You can cause damage to the bypass and connected equipment.*

NOTICE *Do not use steam or other disinfectants to fumigate wood for packaging the bypass. Use alternative methods, for example heat treatment, before you package the components. Gas from wood packaging fumigated with halogen disinfectants, for example fluorine, chlorine, bromine, iodine or DOP gas (phthalic acid ester), can cause damage to the bypass.*

■ Warning Labels

The drive warning label is in the location shown in [Figure i.1](#). Use the drive as specified by this information.

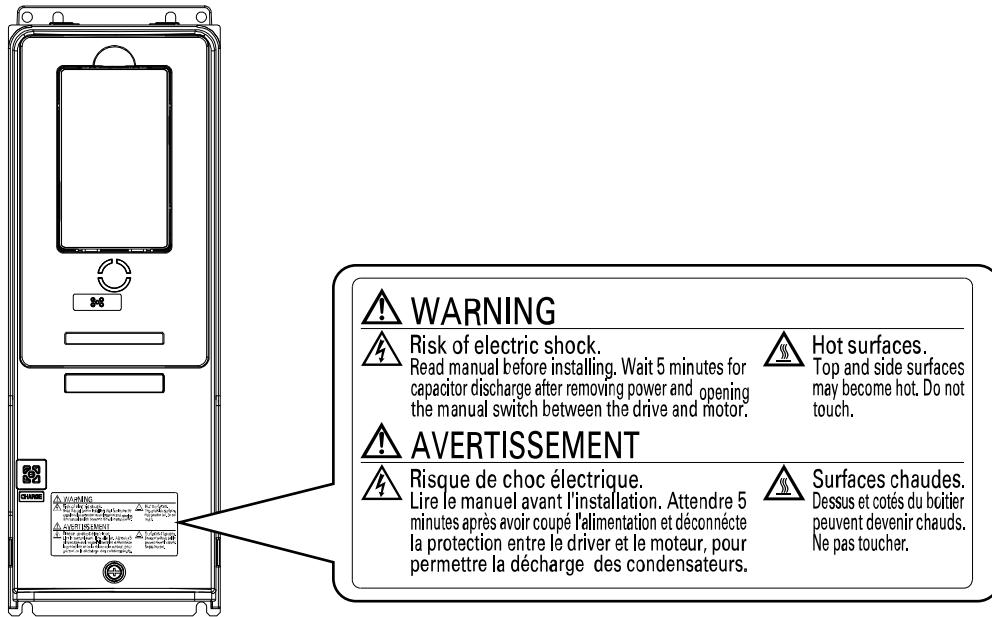

Figure i.1 Drive Warning Label Content and Location

The bypass warning labels are in the locations shown in Figure i.2. Use the bypass as specified by this information.

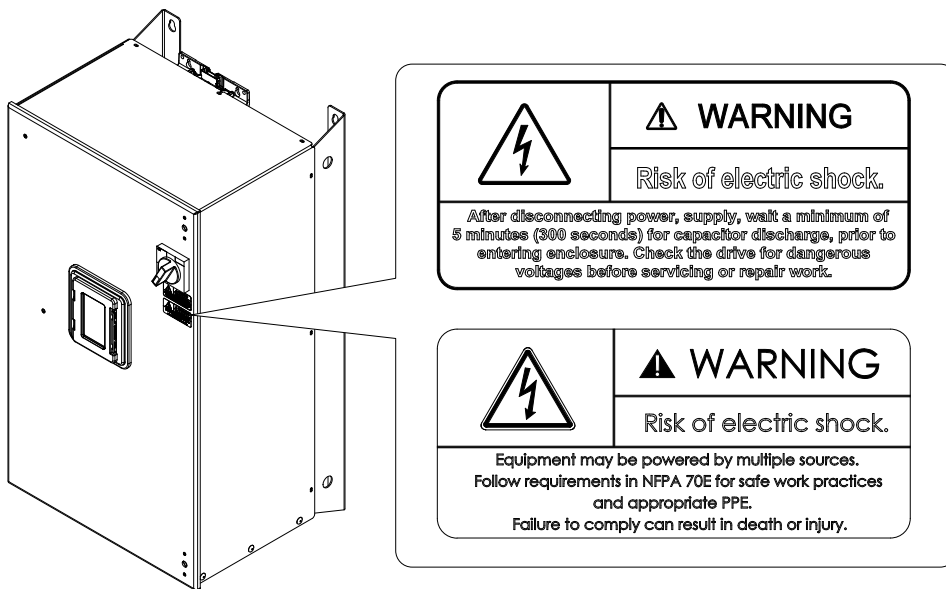

Figure i.2 Bypass Warning Labels and Locations

■ Cybersecurity

This product is designed to connect and communicate information and data through a network interface. It is the sole responsibility of the customer to provide and continuously guarantee a secure connection between the product and the customer's network or if applicable, any other network. The customer must establish and maintain the appropriate measures (such as, but not limited to, the installation of firewalls, the application of authentication measures, the encryption of data, the installation of antivirus programs, etc.) to protect the product, the network, its system and the interface against all types of security breaches, unauthorized access, interference, intrusion, leakage and/or theft of data or information. Yaskawa and its affiliates are not responsible for damages and/or losses related to such security breaches, any unauthorized access, interference, intrusion, leakage and/or theft of data or information.

◆ Warranty Information

■ Exclusion of Liability

- This product is not designed and manufactured for use in life-support machines or systems.
- Contact a Yaskawa representative or your Yaskawa sales representative if you are considering the application of this product for special purposes, such as machines or systems used for passenger cars, medicine, airplanes and aerospace, nuclear power, electric power, or undersea relaying.

⚠ WARNING *Injury to Personnel. When you use this product in applications where its failure could cause the loss of human life, a serious accident, or physical injury, you must install applicable safety devices. If you do not correctly install safety devices, it can cause serious injury or death.*

1 Receiving

This chapter gives information about the different drive models and features, and how to examine the drive when you receive it.

◆ Section Safety

⚠ DANGER Do not ignore the safety messages in this manual. If you ignore the safety messages in this manual, it will cause serious injury or death. The manufacturer is not responsible for injuries or damage to equipment.

◆ Catalog Code and Nameplate Check

Please examine these items after you received the bypass:

- Examine the bypass and drive for damage or missing parts. Immediately contact the shipping company if there is damage. The Yaskawa warranty does not cover damage from shipping.
- Examine the model number on the bypass nameplate to make sure that you received the correct model.
- If you received a product different than what you ordered or your product has a defect, contact Yaskawa or your nearest sales representative.

■ Enclosed Bypass Nameplate

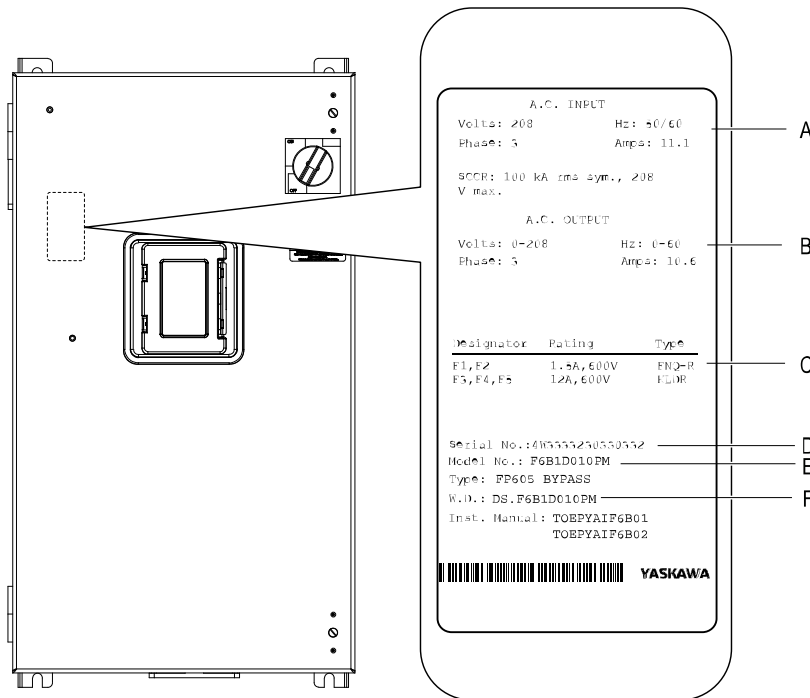

A - Input specifications

B - Output specifications

C - Replacement fuse specifications

D - Serial number

E - Bypass model number

F - Schematic document number

Figure 1.1 Enclosed Bypass Nameplate Location Example

Note:

The nameplate and seismic certification label are also on the outside of the enclosure.

■ Drive Nameplate

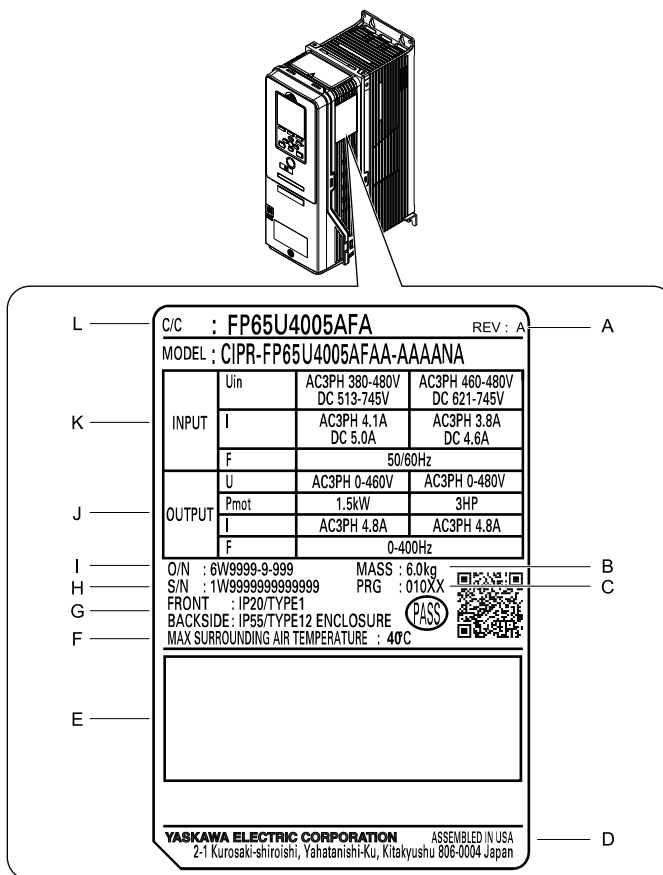

- A - Hardware revision
- B - Weight
- C - Drive software version
- D - The address of the head office of Yaskawa Electric Corporation
- E - Accreditation standards
- F - Surrounding air temperature
- G - Protection design
- H - Serial number
- I - Lot number
- J - Output specifications
- K - Input specifications
- L - Catalog code

Figure 1.2 Nameplate Location

■ How to Read Enclosed Bypass Catalog Codes

Use the information in Figure 1.3 and Table 1.1 to read the bypass catalog codes.

F6B 1 A 040P ^{D/E/C/M} T ^{D/E/G/H/K} S ^B
_{1 2 3 4 5 6 7}
_{B/F/G L/N/Q/W/Z}

Figure 1.3 Enclosed Bypass Catalog Code

Table 1.1 Enclosed Bypass Catalog Code Details

No.	Description
1	Product series
2	Enclosure type <ul style="list-style-type: none"> • 1: UL Type 1 Enclosed • 2: UL Type 12 Enclosed • 3: ULType 3R Enclosed

1 Receiving

No.	Description
3	Input power supply voltage <ul style="list-style-type: none"> • D: Three-Phase 208 V • A: Three-Phase 240 V • B: Three-Phase 480 V
4	Bypass output amps
5	Power options <ul style="list-style-type: none"> • E: Lockable circuit breaker (min kA SCCR Panel Rating) • C: Lockable circuit breaker (65 kA SCCR Panel Rating) • M: Lockable circuit breaker (100 kA SCCR Panel Rating) • F: Input fuses • G: Drive input service switch • B: 3-contactor bypass • 3: Space heater (Type 3R only) • 4: 50 °C ambient (Type 3R only)
6	Control options <ul style="list-style-type: none"> • D: EtherNet/IP dual-port • G: DeviceNet • H: PROFIBUS-DP • L: LonWorks • Q: Modbus TCP/IP • E: Digital output • N: Analog output • W: Custom nameplate • M: Keypad viewing window (Type 3R only) • Z: Speed potentiometer • K: Control transformer - 200 VA additional
7	Special options <ul style="list-style-type: none"> • B: Bluetooth keypad

Enclosed Bypass Models, Drive Models, and Capacities

Table 1.2 Three-Phase AC 208 V Enclosed Models and Capacities (NEMA Rating, Type 1 Enclosure)

Bypass Model F6B1	Capacity			Drive Catalog Code FP65U	Electrical Schematic	Weight (lb)
	HP	Input (A)	Output (A)			
D004	1	6.0	4.6	2011	DS.F6B1.01	93
D007	2	8.9	7.5	2011	DS.F6B1.01	93
D010	3	12.0	10.6	2011	DS.F6B1.01	93
D016	5	18.1	16.7	2017	DS.F6B1.01	93
D024	7.5	25.6	24.2	2024	DS.F6B1.01	125
D030	10	32.2	30.8	2031	DS.F6B1.01	128
D046	15	48.6	46.2	2046	DS.F6B1.01	159
D059	20	61.8	59.4	2059	DS.F6B1.01	163
D074	25	77.2	74.8	2075	DS.F6B1.01	224
D088	30	90.4	88	2088	DS.F6B1.01	233
D114	40	116.4	114	2114	DS.F6B1.01	248
D143	50	145.4	143	2143	DS.F6B1.01	419
D169	60	171.4	169	2169	DS.F6B1.01	434
D211	75	213.4	211	2211	DS.F6B1.01	832
D273	100	275.4	273	2273	DS.F6B1.01	859

Table 1.3 Three-Phase AC 240 V Enclosed Models and Capacities (NEMA Rating, Type 1 Enclosure)

Bypass Model F6B1	Capacity			Drive Catalog Code FP65U	Electrical Schematic	Weight (lb)
	HP	Input (A)	Output (A)			
A004	1	5.5	4.2	2011	DS.F6B1.01	93
A006	2	8.1	6.8	2011	DS.F6B1.01	93
A009	3	10.9	9.6	2011	DS.F6B1.01	93
A015	5	16.5	15.2	2017	DS.F6B1.01	93
A022	7.5	23.3	22	2024	DS.F6B1.01	125
A028	10	29.3	28	2031	DS.F6B1.01	128
A042	15	44.1	42	2046	DS.F6B1.01	159
A054	20	56.1	54	2059	DS.F6B1.01	163
A068	25	70.1	68	2075	DS.F6B1.01	224
A080	30	82.1	80	2088	DS.F6B1.01	228
A104	40	106.1	104	2114	DS.F6B1.01	243
A130	50	132.1	130	2143	DS.F6B1.01	414
A154	60	156.1	154	2169	DS.F6B1.01	430
A192	75	193.3	192	2211	DS.F6B1.01	803
A248	100	250.1	248	2273	DS.F6B1.01	859

Table 1.4 Three-Phase AC 480 V Enclosed Models and Capacities (NEMA Rating, Type 1 Enclosure)

Bypass Model F6B1	Capacity			Drive Catalog Code FP65U	Electrical Schematic	Weight (lb)
	HP	Input (A)	Output (A)			
B002	1	2.7	2.1	4005	DS.F6B1.01	93
B003	2	4.0	3.4	4005	DS.F6B1.01	93
B004	3	5.4	4.8	4005	DS.F6B1.01	93
B007	5	8.2	7.6	4008	DS.F6B1.01	94
B011	7.5	11.6	11	4011	DS.F6B1.01	94
B014	10	14.6	14	4014	DS.F6B1.01	94
B021	15	21.6	21	4021	DS.F6B1.01	125
B027	20	27.6	27	4027	DS.F6B1.01	129
B034	25	35.0	34	4034	DS.F6B1.01	137
B040	30	41.0	40	4040	DS.F6B1.01	162
B052	40	53.0	52	4052	DS.F6B1.01	168
B065	50	66.0	65	4065	DS.F6B1.01	179
B077	60	78.0	77	4077	DS.F6B1.01	233
B096	75	97.0	96	4096	DS.F6B1.01	247
B124	100	125.0	124	4124	DS.F6B1.01	263
B156	125	157.0	156	4156	DS.F6B1.01	431
B180	150	180.6	180	4180	DS.F6B1.01	803
B240	200	241.0	240	4240	DS.F6B1.01	857
B302	250	303.0	302	4302	DS.F6B1.01	964

2 Mechanical Installation

This chapter explains how to properly mount and install the drive.

◆ Section Safety

⚠ WARNING *Electrical Shock Hazard. Only let approved personnel install, wire, maintain, examine, replace parts, and repair the bypass. If personnel are not approved, it can cause serious injury or death.*

⚠ WARNING *Electrical Shock Hazard. Do not modify the bypass body, drive body, bypass circuitry, or drive circuitry. Modifications to bypass and drive body and circuitry can cause serious injury or death, will cause damage to the bypass and drive, and will void the warranty. Yaskawa is not responsible for modifications of the product made by the user.*

⚠ WARNING *Fire Hazard. Do not put flammable or combustible materials on top of the bypass and do not install the bypass near flammable or combustible materials. Attach the bypass to metal or other noncombustible material. Flammable and combustible materials can start a fire and cause serious injury or death.*

⚠ WARNING *Crush Hazard. Only approved personnel can operate a crane or hoist to move the bypass. If unapproved personnel operate a crane or hoist, it can cause serious injury or death from falling equipment.*

⚠ WARNING *Crush Hazard. Before you hang the bypass vertically, use screws to correctly attach the front cover and other components. If you do not secure the front cover, it can fall and cause minor injury.*

⚠ WARNING *Crush Hazard. When you use a crane or hoist to lift the bypass during installation or removal, prevent more than 1.96 m/s² (0.2 G) vibration or impact. Too much vibration or impact can cause serious injury or death from falling equipment.*

⚠ WARNING *Crush Hazard. When you lift the bypass during installation or removal, do not try to turn it over and do not ignore a hanging bypass. If you move a hanging bypass too much or if you ignore it, it can fall and cause serious injury or death.*

⚠ WARNING *Crush Hazard. Use a crane or hoist to move large bypasses when necessary. If you try to move a large bypass without a crane or hoist, it can cause serious injury or death.*

⚠ CAUTION *Crush Hazard. Tighten terminal cover screws and hold the case safely when you move the bypass. If the bypass or covers fall, it can cause moderate injury.*

NOTICE *Do not let unwanted objects, for example metal shavings or wire clippings, fall into the bypass during installation. Put a temporary cover over the bypass during installation. Remove the temporary cover before start-up. Unwanted objects inside of the bypass can cause damage to the bypass.*

NOTICE *Damage to Equipment. When you touch the drive and bypass circuit boards, make sure that you observe correct electrostatic discharge (ESD) procedures. If you do not follow procedures, it can cause ESD damage to the drive and bypass circuitry.*

NOTICE *Install vibration-proof rubber on the base of the motor or use the frequency jump function in the bypass to prevent specific frequencies that vibrate the motor. Motor or system resonant vibration can occur in fixed speed machines that are converted to variable speed. Too much vibration can cause damage to equipment.*

◆ Installation Environment

The installation environment is important for the lifespan of the product and to make sure that the bypass performance is correct. Make sure that the installation environment agrees with these specifications.

Environment	Conditions
Area of Use	Indoors
Ambient Temperature Setting	UL Type 1: -10 °C to +40 °C (14 °F to 104 °F) UL Type 12: -10 °C to +40 °C (14 °F to 104 °F) UL Type 3R: -10 °C to +40 °C (14 °F to 104 °F) • Do not let the bypass freeze.
Humidity	98% RH or less Do not let condensation form on the bypass.
Storage Temperature	-20 °C to +70 °C (-4 °F to +158 °F) (short-term temperature during transportation)
Surrounding Area	Pollution degree 2 or less Install the bypass in an area without: <ul style="list-style-type: none"> • Oil mist, corrosive or flammable gas, or dust • Metal powder, oil, water, or other unwanted materials • Radioactive materials or flammable materials, including wood • Harmful gas or fluids • Salt • Direct sunlight Keep wood and other flammable materials away from the bypass.

Environment	Conditions
Altitude	1000 m (3281 ft) maximum Note: Derate the output current by 1% for each 100 m (328 ft) to install the bypass in altitudes between 1000 m to 4000 m (3281 ft to 13123 ft). It is not necessary to derate the rated voltage in these conditions: <ul style="list-style-type: none"> • When you install the bypass at 2000 m (6562 ft) or lower • When you install the bypass between 2000 m to 4000 m (6562 ft to 13123 ft) and ground the neutral point on the power supply.
Vibration	<ul style="list-style-type: none"> • 10 Hz to 20 Hz: 1 G (9.8 m/s², 32.15 ft/s²) • 20 Hz to 55 Hz: F6B1D004 to D030, F6B1A004 to A028, F6B1B002 to B034: 0.6 G (5.9 m/s², 19.36 ft/s²) F6B1D046 to D273, F6B1A042 to A248, F6B1B040 to B302: 0.2 G (1.96 m/s², 6.43 ft/s²)
Installation Orientation	Install the bypass vertically for sufficient cooling airflow.

NOTICE Do not let unwanted objects, for example metal shavings or wire clippings, fall into the bypass during installation. Put a temporary cover over the bypass during installation. Remove the temporary cover before start-up. Unwanted objects inside of the bypass can cause damage to the bypass.

Note:

Do not put peripheral devices, transformers, or other electronics near the bypass. Shield the bypass from electrical interference if components must be near the bypass. The bypass or the devices around the bypass may malfunction due to electrical interference.

◆ Enclosed Bypass Installation Position and Clearances

■ Installation Dimensions

Refer to the Dimension Drawing (DD.FB.x.xx.xx) packaged with the bypass for exterior and mounting dimensions for your model.

■ Installation Position

Install the bypass vertically for sufficient cooling airflow.

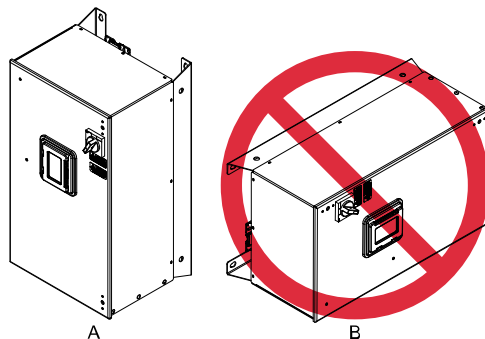

A - Vertical installation

B - Horizontal installation

Figure 2.1 Installation Position

■ Single Enclosed Bypass Installation Clearances

Use the clearances specified in [Figure 2.2](#) to install the bypass. Make sure that there is sufficient space for wiring and airflow.

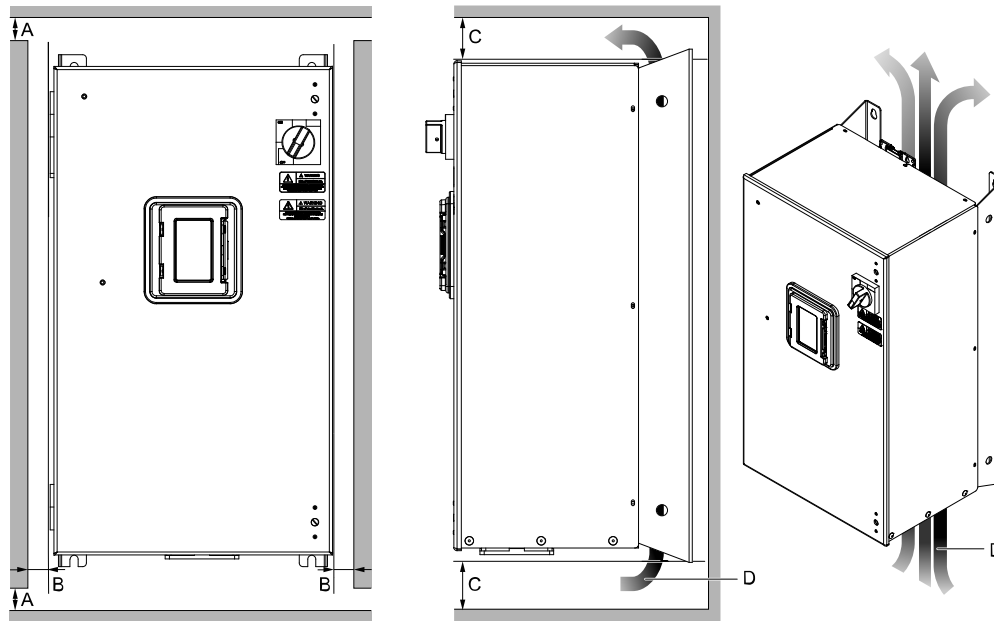

A - 50 mm (2 in) minimum
B - 102 mm (4 in) minimum

C - 152 mm (6 in) minimum *
D - Airflow direction

Figure 2.2 Single Bypass Installation

*1 This is the distance from a component or mounting bracket that has the maximum height. The highest component is different for different models.

◆ Bypass Components

■ Input Disconnect Switch

Electrically located on the input power side of the bypass, the door mounted rotary input disconnect switch provides a way to disconnect bypass from line power for equipment maintenance. Put the disconnect in the OFF position to open the bypass enclosure door. When open, you can use a padlock to lock the handle in the OFF position. The customer must supply branch short circuit protection for the bypass.

■ Contactors

The bypass is a 2-contactor or 3-contactor bypass circuit employing IEC rated contactors in an electrically interlocked arrangement to allow mutually exclusive operation in Drive or Bypass modes.

The control logic and “soft start” characteristic of the drive limit the drive input and output contactors to motor FLA current or less. For this reason, the drive output contactor has a lower current rating than the bypass contactor. The bypass contactor is exposed to motor inrush current (LRA) when starting the motor across-the-line and therefore requires a higher current rating.

■ Overload Relay

Electronic overload relay consists of bypass relay board and two pass-through current transformers. Overload relay functions, settings, adjustments and reset operations are done through the keypad. The bypass three-phase output power connection to the motor is made to terminal block TB3.

■ Control Power Transformer

A Control Power Transformer (CPT) is provided to power the bypass 120 Vac control circuit. The VA capacity is determined by the control circuit and optional functions specified for the unit. The CPT primary is fused in both legs, the secondary is fused when required by NEC (transformer VA and wire size dependent). One side of the transformer secondary is grounded to the bypass enclosure.

◆ Bypass Component Names

■ Enclosed Bypass Component Names

This section gives an overview of the Enclosed Bypass components described in this manual.

208 V Enclosed Models: F6B1D004 to D273

240 V Enclosed Models: F6B1A004 to A248

480 V Enclosed Models: F6B1B002 to B302

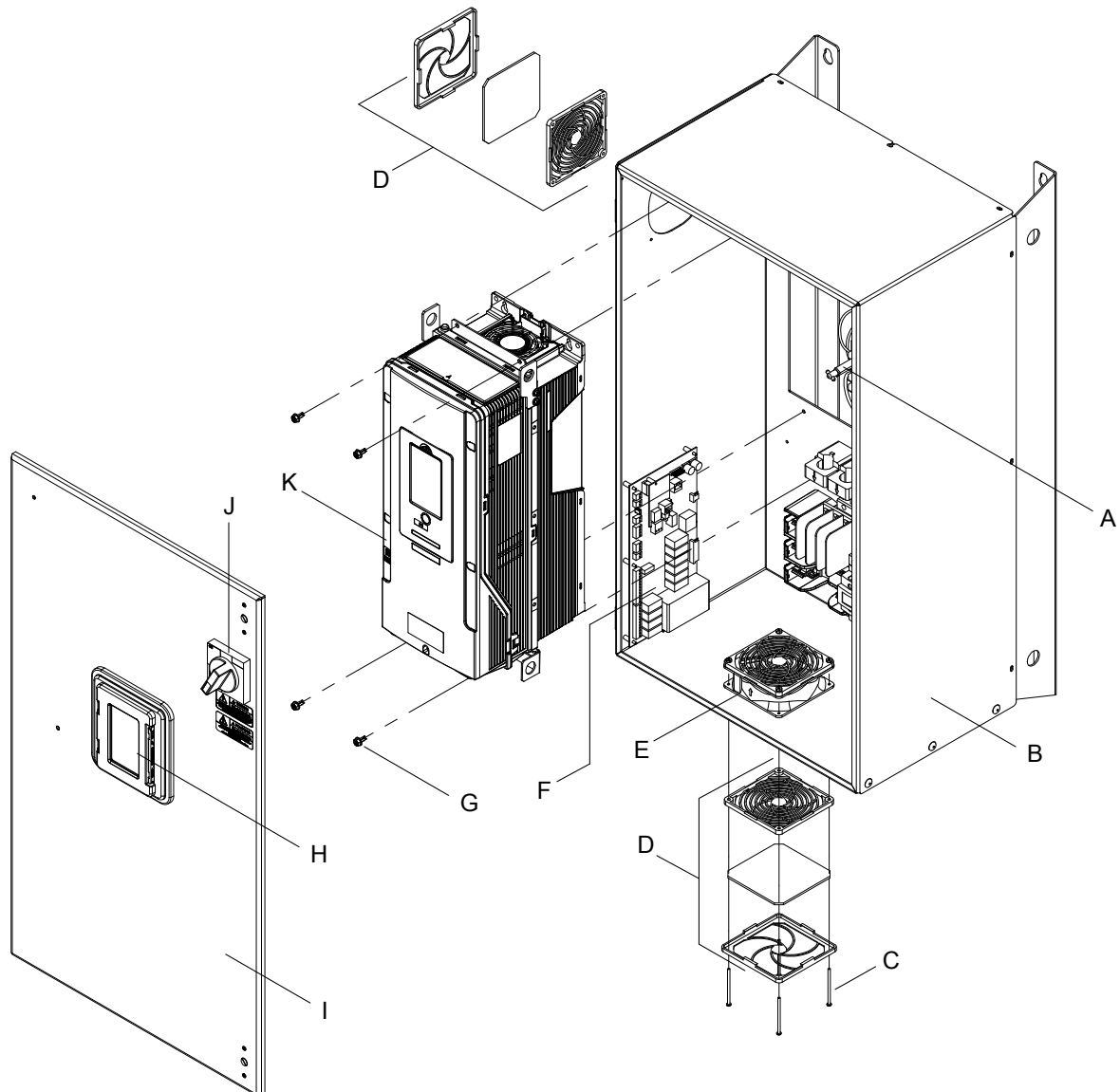

- | | |
|--------------------------|---------------------------------|
| A - Disconnect shaft | G - Drive mounting screws |
| B - Bypass enclosure | H - Keypad |
| C - Fan mounting screws | I - Bypass enclosure front door |
| D - Fan cover assembly | J - Disconnect switch handle |
| E - Bypass enclosure fan | K - FP605 drive |
| F - Bypass PCB A2 | |

Figure 2.3 Exploded View of Components (Enclosed Model D046 Example)

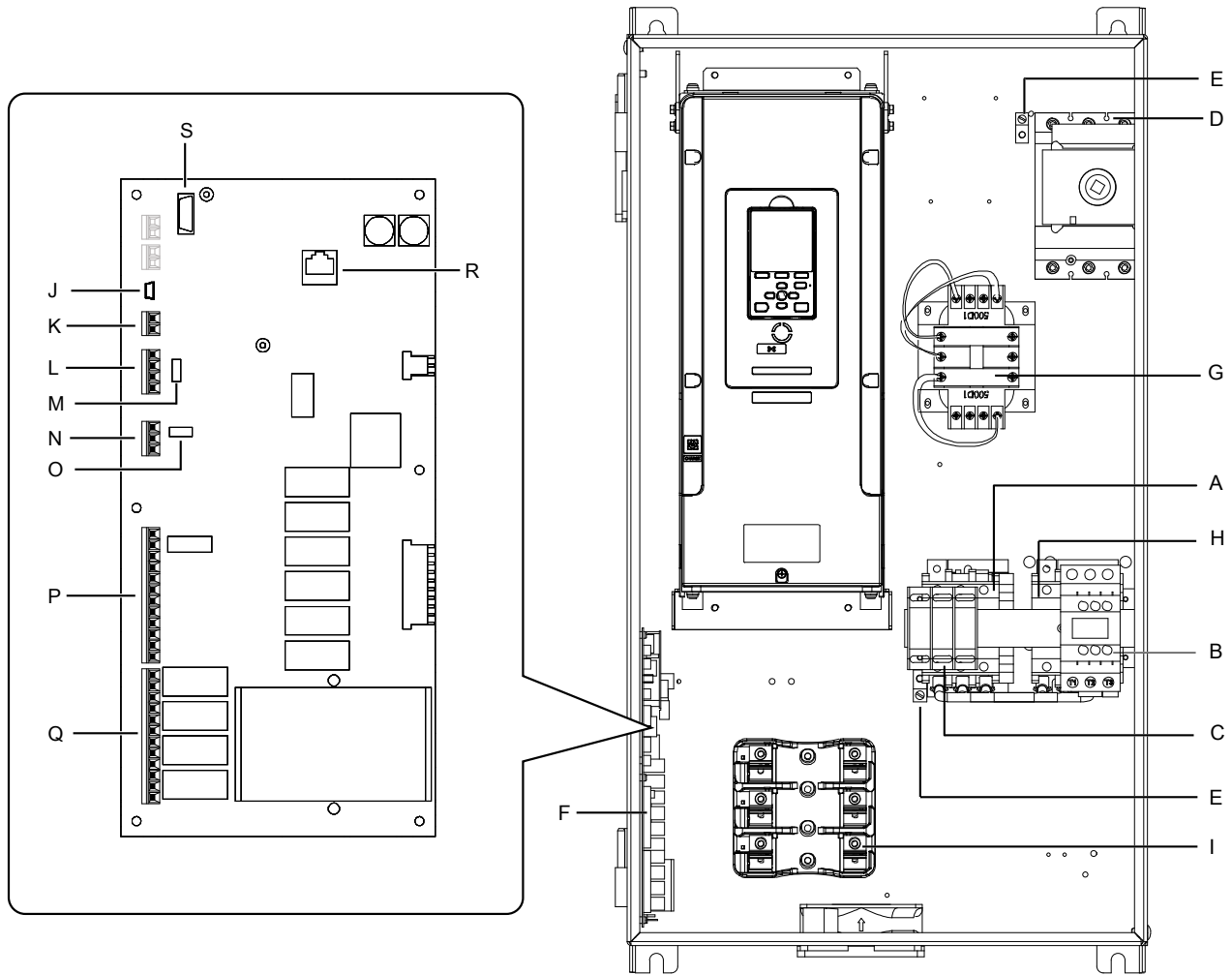

- | | |
|---|--|
| <p>A - Output contactor K2</p> <p>B - Input contactor K1</p> <p>C - Motor connections</p> <p>D - Input power terminals</p> <p>E - Ground terminals</p> <p>F - Bypass PCB A2 control board</p> <p>G - 120 V control transformer</p> <p>H - Bypass contactor K3</p> <p>I - Fuse block</p> <p>J - USB port CN1</p> | <p>K - Terminal TB6 (Ground)</p> <p>L - Terminal TB3 (Serial Comms)</p> <p>M - RS-485 terminator switch S1</p> <p>N - Terminal TB4 (Analog Input)</p> <p>O - Analog input V or I switch S2</p> <p>P - Terminal TB2 (Digital Inputs)</p> <p>Q - Terminal TB1 (Digital Outputs)</p> <p>R - Digital operator port CN2</p> <p>S - Option card connector CN5</p> |
|---|--|

Figure 2.4 Front View of Enclosed Components

◆ Moving the Bypass

Obey local laws and regulations when you move and install this product.

⚠ CAUTION *Crush Hazard. Tighten terminal cover screws and hold the case safely when you move the bypass. If the bypass or covers fall, it can cause moderate injury.*

Bypass Weight	Persons Necessary to Move the Bypass
< 15 kg (33 lbs.)	1
≥ 15 kg (33 lbs.)	2 + using appropriate lifting equipment

Refer to [Using the Mounting Rails to Move the Bypass on page 21](#) for information about how to use suspension systems, wires, or hanging metal brackets to move the bypass.

■ Using the Mounting Rails to Move the Bypass

Use the holes in the mounting rails attached to the bypass to temporarily lift the bypass when you install it. Do not let the bypass stay vertically or horizontally suspended or move the bypass over a long distance while it is suspended.

Before you install the bypass, make sure that you read these precautions:

⚠ WARNING *Crush Hazard. Before you hang the bypass vertically, use screws to correctly attach the front cover and other components. If you do not secure the front cover, it can fall and cause minor injury.*

⚠ WARNING *Crush Hazard. When you use a crane or hoist to lift the bypass during installation or removal, prevent more than 1.96 m/s² (0.2 G) vibration or impact. Too much vibration or impact can cause serious injury or death from falling equipment.*

⚠ WARNING *Crush Hazard. When you lift the bypass during installation or removal, do not try to turn it over and do not ignore a hanging bypass. If you move a hanging bypass too much or if you ignore it, it can fall and cause serious injury or death.*

Vertical Suspension

To use the hanging brackets to vertically suspend the drive, lift the drive with this procedure:

1. Put wire through the two holes in the hanging brackets.

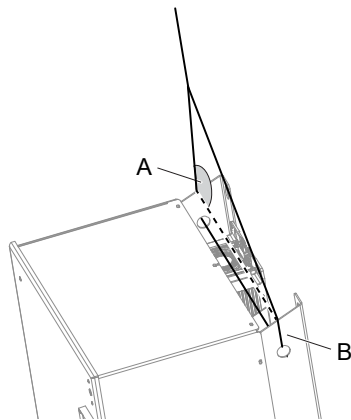

A - Suspension angle of at least 50 degrees

B - Hanging bracket (2)

Figure 2.5 Vertical Suspension

2. Use a crane to gradually wind up the wire. Visually make sure that there is sufficient tension in the wire, then lift the drive to its correct location.
3. Prepare the control panel for installation, then lower the drive.

Note:

When you lower the drive, stop before the drive touches the floor, then slowly lower it the remaining distance.

Horizontal Suspension

When horizontal suspension is necessary, use this procedure to hang the bypass:

- Put the bypass on the ground horizontally.

NOTICE When you attach a horizontal lifting cable or chain to the bypass, use a jig or pad between the wire and the bypass. The wire can scratch the drive and cause damage to the bypass.

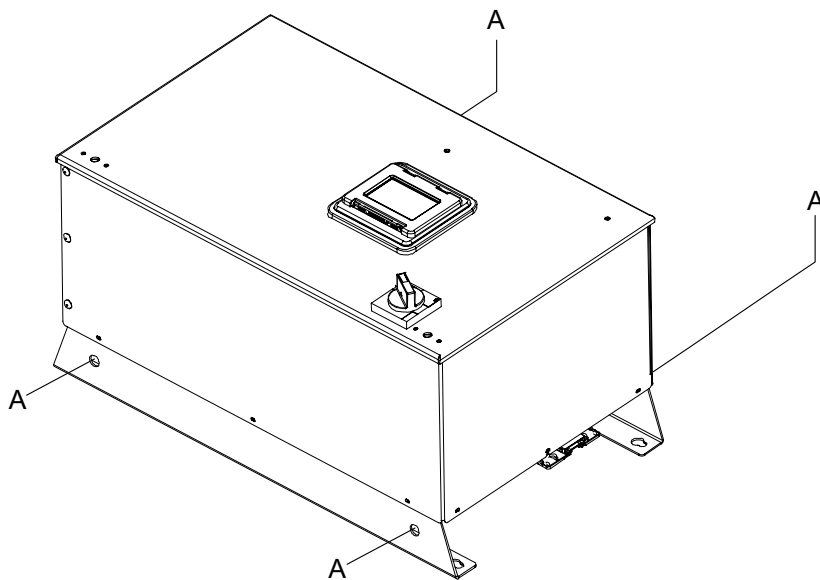

A - Hanging bracket (4)

Figure 2.6 Horizontal Suspension

- Connect to the four hanging brackets.
- Use a crane to lift the bypass.

◆ Removing/Reattaching Covers

This section gives information about how to open and close and remove and reattach the bypass front door and drive front cover and terminal cover for wiring and inspection.

Table 2.1 Procedures to Remove Enclosed Covers by Model

Bypass Model F6B1	Opening the Bypass Door	Removing the Drive Cover
D004 - D114 A004 - A104 B002 - B124	Procedure 1 22	Procedure A 24
D143 - D273 A130 - A248 B156 - B302		Procedure B 24

■ Opening/Closing the Bypass Door Using Procedure 1

Note:

The steps to open and close the front door are different for different enclosure types and seismic ratings. The example shown here is for a standard UL Type 1 enclosure.

- De-energize the system at the power source. Observe correct lockout/tagout safety procedures. Turn the disconnect handle to the “OFF” position

⚠ DANGER Electrical Shock Hazard. Do not examine, connect, or disconnect wiring on an energized bypass. Before servicing, disconnect all power to the equipment and wait for the time specified on the warning label at a minimum. The internal capacitor stays charged after the bypass is de-energized. The charge indicator LED extinguishes when the DC bus voltage decreases below 50 VDC. When all indicators are OFF, remove the covers before measuring for dangerous voltages to make sure that the bypass is safe. If you do work on the bypass when it is energized, it will cause serious injury or death from electrical shock.

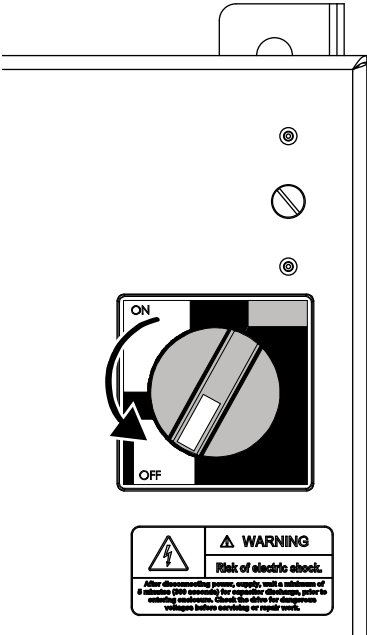

Figure 2.7 Disconnect Power

- 2. Turn the flat head screw fasteners on the cover 1/2 turn counter-clockwise.

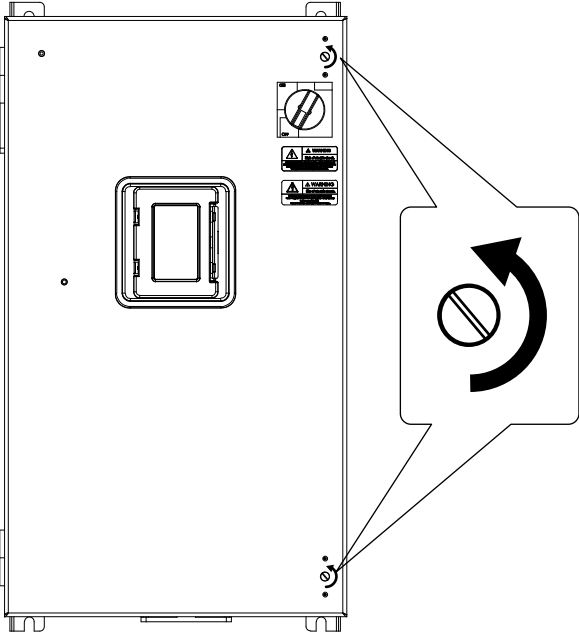

Figure 2.8 Turn the Screw Fasteners

3. The door will now swing open on hinges located on left side of the bypass.

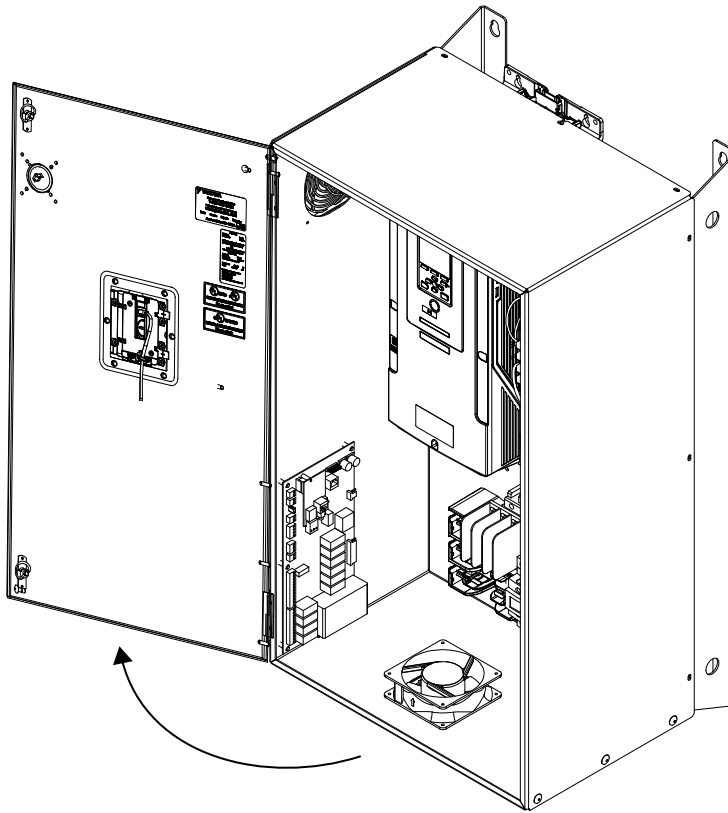

Figure 2.9 Swing Open Door

4. Reverse the steps to close the cover.

■ Removing/Reattaching the Drive Cover Using Procedure A

⚠ DANGER *Electrical Shock Hazard. Do not examine, connect, or disconnect wiring on an energized bypass. Before servicing, disconnect all power to the equipment and wait for the time specified on the warning label at a minimum. The internal capacitor stays charged after the bypass is de-energized. The charge indicator LED extinguishes when the DC bus voltage decreases below 50 VDC. When all indicators are OFF, remove the covers before measuring for dangerous voltages to make sure that the bypass is safe. If you do work on the bypass when it is energized, it will cause serious injury or death from electrical shock.*

Remove the Front Cover

1. Remove the bypass front cover in Procedure A
2. Loosen the front cover screw.

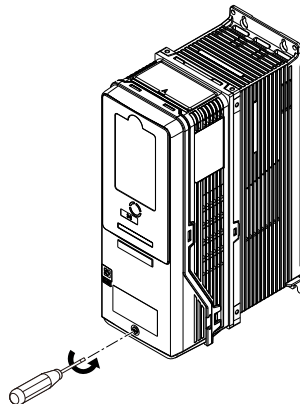

Figure 2.10 Loosen the Front Cover Screw

3. Push on the tabs in the sides of the front cover then pull the front cover forward to remove it from the drive.

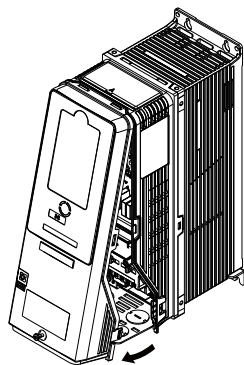

Figure 2.11 Remove the Front Cover

Reattach the Front Cover

1. Wire the drive and other peripheral devices.
2. Reverse the steps to reattach the cover.

Note:

- Make sure that you did not pinch wires or signal lines between the front cover and the drive before you reattach the cover.
- Make sure that the tabs on the sides of the front cover correctly click into the hook.
- Tighten the screws to a tightening torque of 0.98 N·m to 1.33 N·m (8.67 in·lb to 11.77 in·lb).

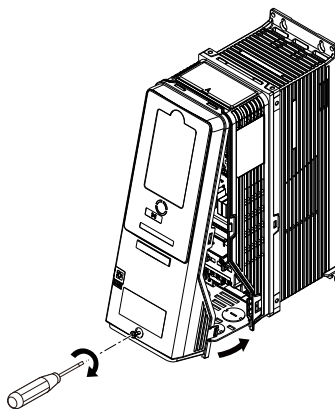

Figure 2.12 Reattach the Front Cover

■ Removing/Reattaching the Cover Using Procedure B

⚠ DANGER *Electrical Shock Hazard. Do not examine, connect, or disconnect wiring on an energized drive. Before servicing, disconnect all power to the equipment and wait for the time specified on the warning label at a minimum. The internal capacitor stays charged after the drive is de-energized. The charge indicator LED extinguishes when the DC bus voltage decreases below 50 Vdc. When all indicators are OFF, remove the covers before measuring for dangerous voltages to make sure that the drive is safe. If you do work on the drive when it is energized, it will cause serious injury or death from electrical shock.*

Remove the Terminal Cover

1. Loosen the screws on the terminal cover, then pull down on the cover.

⚠ CAUTION *Crush Hazard. Loosen the cover screws. Do not fully remove them. If you fully remove the cover screws, the terminal cover can fall and cause moderate injury.*

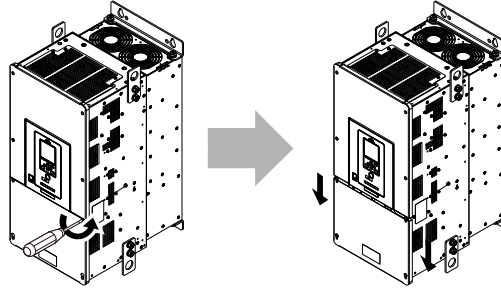

Figure 2.13 Loosen the Terminal Cover Mounting Screws

2. Pull the terminal cover away from the drive.

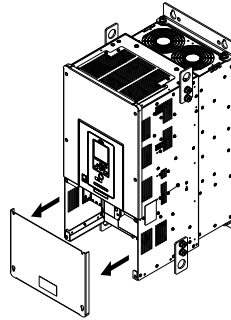
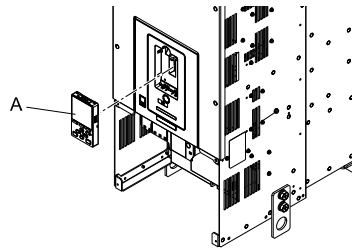

Figure 2.14 Remove the Terminal Cover

Remove the Front Cover

1. Remove the keypad from the drive.



A - Keypad

Figure 2.15 Remove the Keypad

2. Loosen the front cover screws.

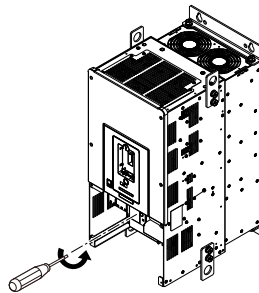
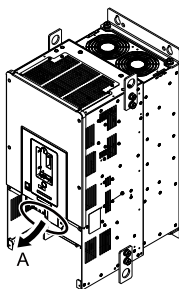

Figure 2.16 Loosen the Front Cover Screws

3. Pull part A of the front cover forward to remove the cover from the drive.



A - Pull forward to remove the front cover.

Figure 2.17 Pull Forward to Remove the Front Cover

4. Remove the front cover from the drive.

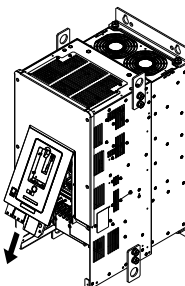
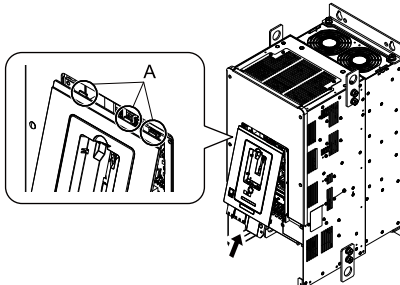

Figure 2.18 Remove the Front Cover

Reattach the Front Cover

Wire the drive and other peripheral devices then reattach the front cover.

1. Move the front cover to connect the hooks at the top of the front cover to the drive.



A - Hooks

Figure 2.19 Reattach the Front Cover

2. Move the front cover while pushing on the hooks on the left and right sides of the front cover until it clicks into position.

Note:

Make sure that you did not pinch wires or signal lines between the front cover and the drive before you reattach the cover.

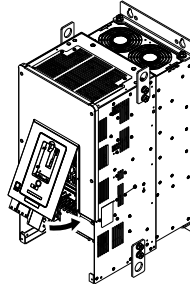

Figure 2.20 Reattach the Front Cover

3. Reattach the keypad to its initial position.

Reattach the Terminal Cover

Wire the drive and other peripheral devices then reattach the terminal cover.

Note:

- Make sure that you do not pinch wires or signal lines between the wiring cover and the drive before you reattach the cover.
- Tighten the screws to a tightening torque of 0.98 N·m to 1.33 N·m (8.67 lbf·in to 11.77 lbf·in).

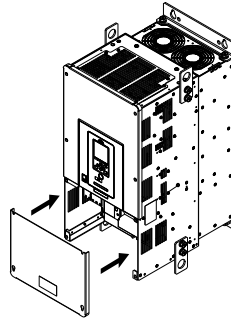

Figure 2.21 Reattach the Terminal Cover

3 Electrical Installation

This chapter explains how to wire the control circuit terminals, motor, and power supply.

◆ Section Safety

⚠ DANGER *Electrical Shock Hazard. Do not examine, connect, or disconnect wiring on an energized bypass. Before servicing, disconnect all power to the equipment and wait for the time specified on the warning label at a minimum. The internal capacitor stays charged after the bypass is de-energized. The charge indicator LED extinguishes when the DC bus voltage decreases below 50 VDC. When all indicators are OFF, remove the covers before measuring for dangerous voltages to make sure that the bypass is safe. If you do work on the bypass when it is energized, it will cause serious injury or death from electrical shock.*

⚠ WARNING *Electrical Shock Hazard. Do not operate the bypass when covers are missing. Replace covers and shields before you operate the bypass. Use the bypass only as specified by the instructions. Some figures in this section include bypasses without covers or safety shields to more clearly show the inside of the bypass. If covers or safety shields are missing from the bypass, it can cause serious injury or death.*

⚠ WARNING *Electrical Shock Hazard. Ground the neutral point on the power supply of the bypass to comply with the EMC Directive before you turn on the EMC filter. If you turn ON the EMC filter, but you do not ground the neutral point, it can cause serious injury or death.*

⚠ WARNING *Electrical Shock Hazard. Make sure that the protective ground wire conforms to technical standards and local safety regulations. The IEC/EN 61800-5-1:2007 standard specifies that you must wire the power supply to automatically de-energize when the protective ground wire disconnects. You can also connect a protective ground wire that has a minimum cross-sectional area of 10 mm² (copper wire) or 16 mm² (aluminum wire). If you do not obey the standards and regulations, it can cause serious injury or death. The leakage current of the bypass will be more than 3.5 mA.*

⚠ WARNING *Electrical Shock Hazard. The bypass can cause a residual current with a DC component in the protective earthing conductor. When a residual current operated protective or monitoring device prevents direct or indirect contact, always use a type B Ground Fault Circuit Interrupter (GFCI) as specified by IEC/EN 60755. If you do not use the correct GFCI, it can cause serious injury or death.*

⚠ WARNING *Electrical Shock Hazard. Do not wear loose clothing or jewelry when you do work on the bypass. Tighten loose clothing and remove all metal objects, for example watches or rings. Loose clothing can catch on the bypass and jewelry can conduct electricity and cause serious injury or death.*

⚠ WARNING *Electrical Shock Hazard. Do not remove covers or touch circuit boards while the bypass is energized. If you touch the internal components of an energized bypass, it can cause serious injury or death.*

⚠ WARNING *Electrical Shock Hazard. Only let approved personnel install, wire, maintain, examine, replace parts, and repair the bypass. If personnel are not approved, it can cause serious injury or death.*

⚠ WARNING *Electrical Shock Hazard. Do not modify the bypass body, drive body, bypass circuitry, or drive circuitry. Modifications to bypass and drive body and circuitry can cause serious injury or death, will cause damage to the bypass and drive, and will void the warranty. Yaskawa is not responsible for modifications of the product made by the user.*

⚠ WARNING *Fire Hazard. Tighten all terminal screws to the correct tightening torque. Connections that are too loose or too tight can cause incorrect operation and damage to the bypass. Incorrect connections can also cause death or serious injury from fire.*

⚠ WARNING *Fire Hazard. Tighten screws at an angle in the specified range shown in this manual. If you tighten the screws at an angle not in the specified range, you can have loose connections that can cause damage to the terminal block or start a fire and cause serious injury or death.*

⚠ WARNING *Damage to Equipment. Do not apply incorrect voltage to the main circuit of the bypass. Operate the bypass in the specified range of the input voltage on the nameplate. Voltages that are higher than the permitted nameplate tolerance can cause damage to the bypass.*

NOTICE *Do not let unwanted objects, for example metal shavings or wire clippings, fall into the bypass during installation. Put a temporary cover over the bypass during installation. Remove the temporary cover before start-up. Unwanted objects inside of the bypass can cause damage to the bypass.*

NOTICE *Damage to Equipment. When you touch the bypass, drive, and circuit boards, make sure that you observe correct electrostatic discharge (ESD) procedures. If you do not follow procedures, it can cause ESD damage to the drive and bypass circuitry.*

NOTICE *Select a motor that is compatible with the load torque and speed range. When 100% continuous torque is necessary at low speed, use an inverter-duty motor. When you use a standard fan-cooled motor, decrease the motor torque in the low-speed range. If you operate a standard fan-cooled motor at low speed and high torque, it will decrease the cooling effects and can cause heat damage.*

NOTICE *Obey the speed range specification of the motor as specified by the manufacturer. When you must operate the motor outside of its specifications, contact the motor manufacturer. If you continuously operate oil-lubricated motors outside of the manufacturer specifications, it can cause damage to the motor bearings.*

NOTICE *When the input voltage is 440 V or higher or the wiring distance is longer than 100 m (328 ft), make sure that the motor insulation voltage is sufficient or use an inverter-duty motor with reinforced insulation. Motor winding and insulation failure can occur.*

NOTICE *Make sure that all connections are correct after you install the bypass and connect peripheral devices. Incorrect connections can cause damage to the bypass.*

Note:

- Torque characteristics are different than when you operate the motor directly from line power. Make sure that you understand the load torque characteristics for the application.
- The current rating of submersible motors is usually higher than the current rating of standard motors for a given motor power. Make sure that the rated output current of the bypass is equal to or more than the current rating of the motor. If the motor wire length is longer than 100 m (328 ft), select the correct wire gauge to adjust for a loss in voltage and prevent a loss of motor torque.
- Do not use unshielded wire for control wiring. Use shielded, twisted-pair wires and ground the shield to the ground terminal of the bypass. Unshielded wire can cause electrical interference and unsatisfactory system performance.

◆ Wiring Diagrams

⚠ DANGER *Electrical Shock Hazard. Do not examine, connect, or disconnect wiring on an energized bypass. Before servicing, disconnect all power to the equipment and wait for the time specified on the warning label at a minimum. The internal capacitor stays charged after the bypass is de-energized. The charge indicator LED extinguishes when the DC bus voltage decreases below 50 VDC. When all indicators are OFF, remove the covers before measuring for dangerous voltages to make sure that the bypass is safe. If you do work on the bypass when it is energized, it will cause serious injury or death from electrical shock.*

⚠ WARNING *Electrical Shock Hazard. De-energize the bypass and wait 5 minutes minimum until the Charge LED turns off. Remove the front cover and terminal cover to do work on wiring, circuit boards, and other parts. Use terminals for their correct function only. Incorrect wiring, incorrect ground connections, and incorrect repair of protective covers can cause death or serious injury.*

⚠ WARNING *Electrical Shock Hazard. Correctly ground the drive before you turn on the EMC filter switch. If you touch electrical equipment that is not grounded, it can cause serious injury or death.*

⚠ WARNING *Electrical Shock Hazard. Use the terminals for the drive only for their intended purpose. Refer to the technical manual for more information about the I/O terminals. Wiring and grounding incorrectly or modifying the cover may damage the equipment or cause injury.*

■ Standard Enclosed Connection Diagram

Wire the bypass as specified by [Figure 3.1](#).

⚠ WARNING *Sudden Movement Hazard. Set the MFDI parameters before you close control circuit switches. Incorrect Run/Stop circuit sequence settings can cause serious injury or death from moving equipment.*

⚠ WARNING *Fire Hazard. Install sufficient branch circuit short circuit protection as specified by applicable codes and this manual. The bypass is suitable for circuits that supply not more than 100,000 RMS symmetrical amperes, 240 Vac maximum (208/240 V), 480 Vac maximum (480 V). Incorrect branch circuit short circuit protection can cause serious injury or death.*

NOTICE *When the input voltage is 440 V or higher or the wiring distance is longer than 100 m (328 ft), make sure that the motor insulation voltage is sufficient or use an inverter-duty motor with reinforced insulation. Motor winding and insulation failure can occur.*

Note:

Do not connect the AC control circuit ground to the drive enclosure. Incorrect ground wiring can cause the control circuit to operate incorrectly.

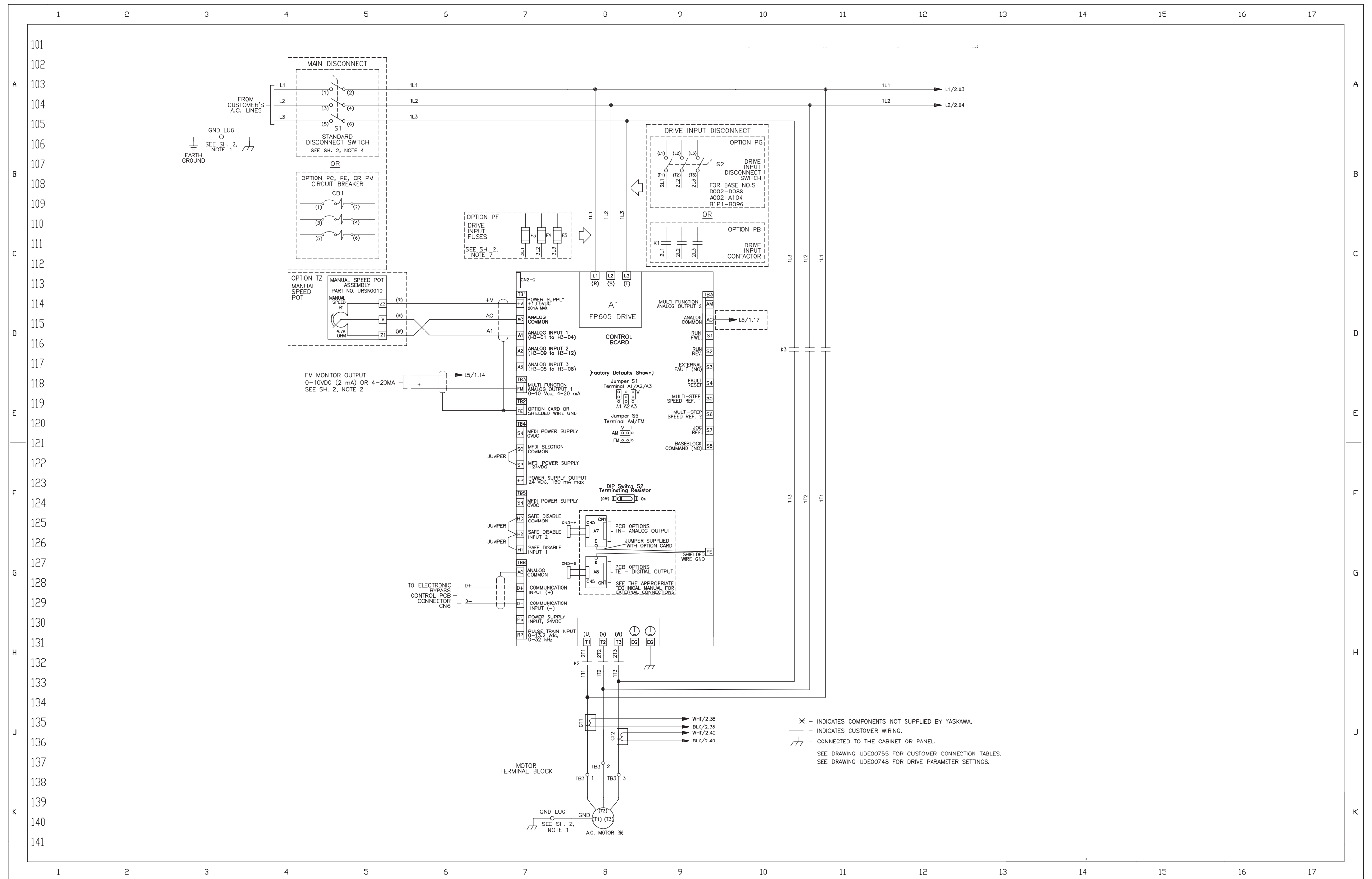
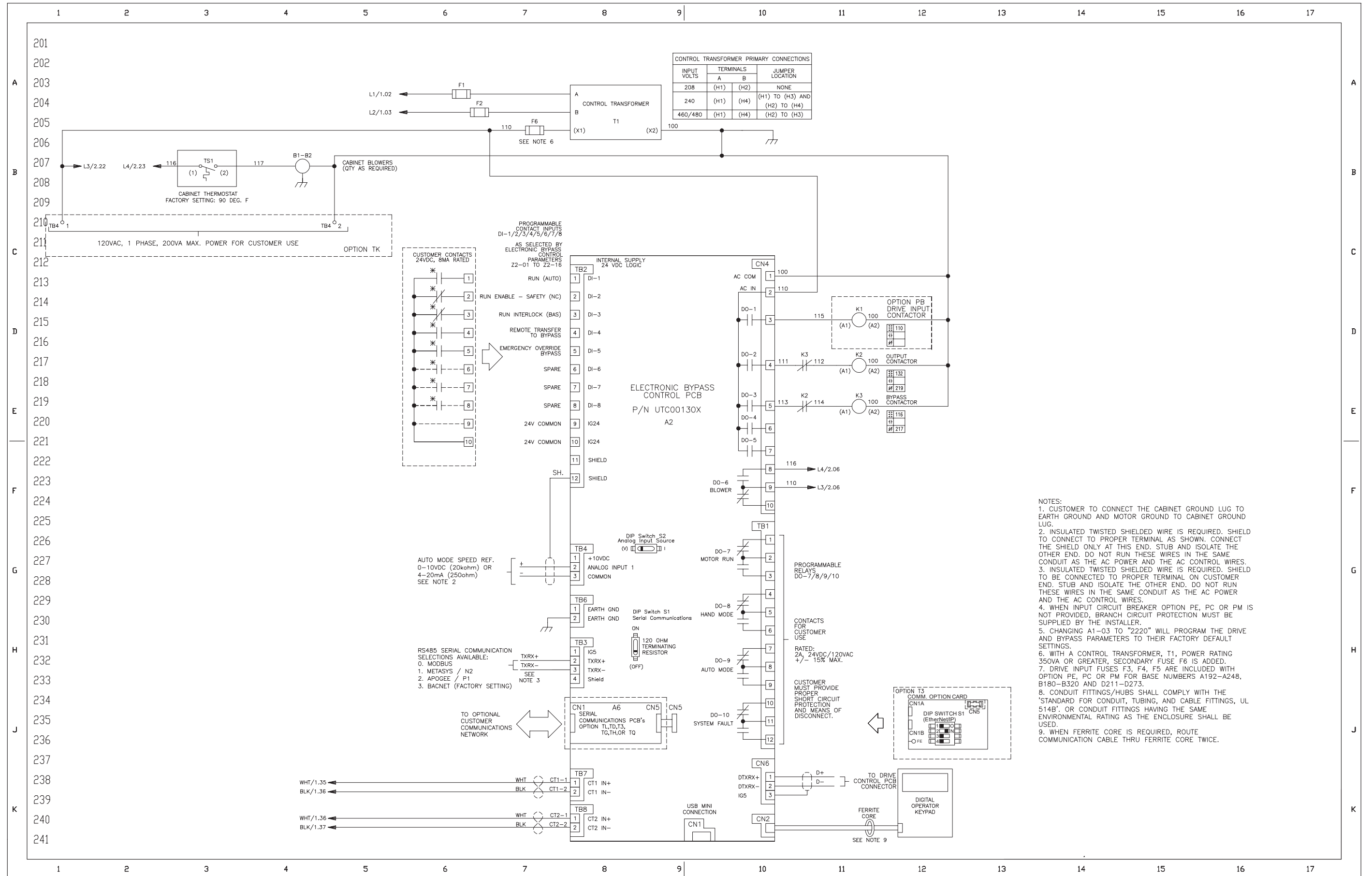

Figure 3.1a Standard Enclosed Bypass Connection Diagram



- NOTES:
1. CUSTOMER TO CONNECT THE CABINET GROUND LUG TO EARTH GROUND AND MOTOR GROUND TO CABINET GROUND LUG.
 2. INSULATED TWISTED SHIELDED WIRE IS REQUIRED. SHIELD TO CONNECT TO PROPER TERMINAL AS SHOWN. CONNECT THE SHIELD ONLY AT THIS END. STUB AND ISOLATE THE OTHER END. DO NOT RUN THESE WIRES IN THE SAME CONDUIT AS THE AC POWER AND THE AC CONTROL WIRES.
 3. INSULATED TWISTED SHIELDED WIRE IS REQUIRED. SHIELD TO BE CONNECTED TO PROPER TERMINAL ON CUSTOMER END. STUB AND ISOLATE THE OTHER END. DO NOT RUN THESE WIRES IN THE SAME CONDUIT AS THE AC POWER AND THE AC CONTROL WIRES.
 4. WHEN INPUT CIRCUIT BREAKER OPTION PE, PC OR PM IS NOT PROVIDED, BRANCH CIRCUIT PROTECTION MUST BE SUPPLIED BY THE INSTALLER.
 5. CHANGING A1-03 TO "2220" WILL PROGRAM THE DRIVE AND BYPASS PARAMETERS TO THEIR FACTORY DEFAULT SETTINGS.
 6. WITH A CONTROL TRANSFORMER, T1, POWER RATING 350VA OR GREATER, SECONDARY FUSE F6 IS ADDED.
 7. DRIVE INPUT FUSES F3, F4, F5 ARE INCLUDED WITH OPTION PE, PC OR PM FOR BASE NUMBERS A192-A248, B180-B320 AND D211-D273.
 8. CONDUIT FITTINGS/HUBS SHALL COMPLY WITH THE 'STANDARD FOR CONDUIT, TUBING, AND CABLE FITTINGS, UL 514B'. OR CONDUIT FITTINGS HAVING THE SAME ENVIRONMENTAL RATING AS THE ENCLOSURE SHALL BE USED.
 9. WHEN FERRITE CORE IS REQUIRED, ROUTE COMMUNICATION CABLE THRU FERRITE CORE TWICE.

Figure 3.1b Standard Enclosed Bypass Connection Diagram (Continued)

◆ Main Circuit Wiring

This section gives information about the functions, specifications, and procedures necessary to safely and correctly wire the main circuit in the bypass.

NOTICE *Damage to Equipment. Do not energize and de-energize the bypass more frequently than one time each 30 minutes. If you frequently energize and de-energize the bypass, it can cause failure.*

Note:

Soldered wire connections can become loose over time and cause unsatisfactory performance.

■ Enclosed Bypass Input and Output Power Wiring Connections

The input disconnect switch is located in the upper right hand side of the bypass. The three-phase input power connection is made to the input terminals of the disconnect. Refer to [Figure 3.2](#) for a representative example. Motor Terminal Block TB3 is mounted to the contactor assembly or back panel (depending on rating), just above the bypass contactor. The bypass three-phase output power connection to the motor is made to Terminal Block TB3.

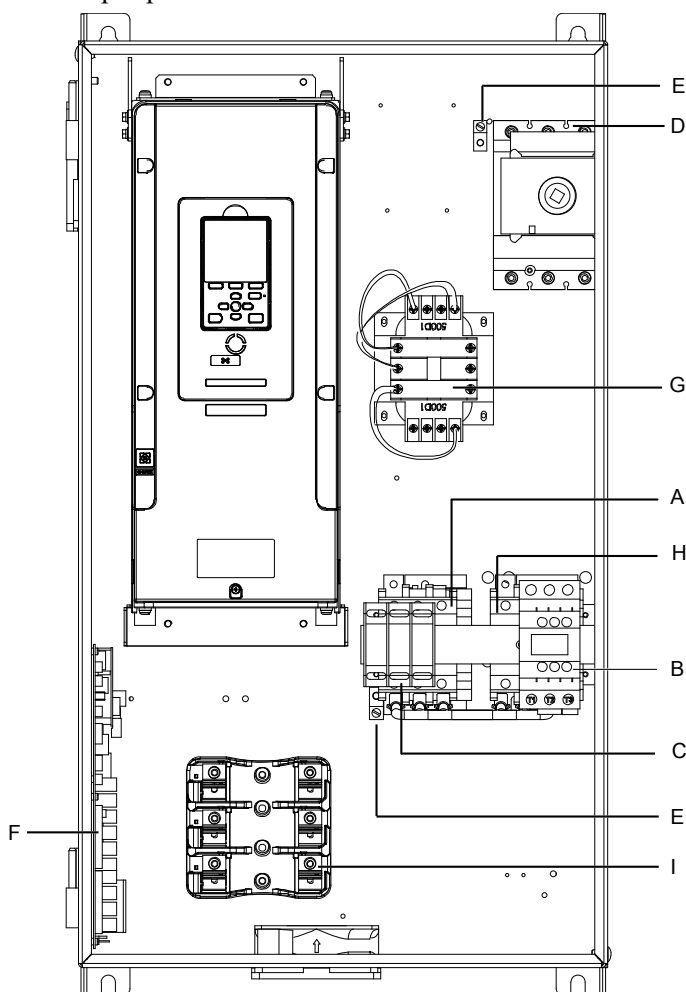

Note:

The location of components are different for different bypass models.

- | | |
|--------------------------------------|--|
| A - Drive output contactor K2 | F - Bypass PCB A2 control board |
| B - Input contactor K1 | G - 120 V control transformer |
| C - Motor connections | H - Bypass contactor K3 |
| D - Input power terminals | I - Fuse block |
| E - Ground screw | |

Figure 3.2 Enclosed Bypass Circuit Components Example

■ Factory Recommended Branch Circuit Protection

⚠ WARNING *Fire Hazard. Branch Circuit protection is required to be installed according to applicable local codes and the requirements listed on the bypass nameplate. The bypass is suitable for use on a circuit capable of delivering not more than 100,000 RMS symmetrical amperes, 208/240 Vac and 480 Vac with the circuit breaker option or when protected by class J or class L fuses as specified on the bypass nameplate. Failure to obey can cause fire and damage to the bypass and drive or injury to personnel.*

■ Wire Selection

Select the correct wires for main circuit wiring.

Wire Selection Precautions

⚠ WARNING *Electrical Shock Hazard. Make sure that the protective ground wire conforms to technical standards and local safety regulations. The IEC/EN 61800-5-1:2007 standard specifies that you must wire the power supply to automatically de-energize when the protective ground wire disconnects. You can also connect a protective ground wire that has a minimum cross-sectional area of 10 mm² (copper wire) or 16 mm² (aluminum wire). If you do not obey the standards and regulations, it can cause serious injury or death. The leakage current of the bypass will be more than 3.5 mA.*

Think about line voltage drop before you select wire gauges. Select wire gauges that drop the voltage by 2% or less of the rated voltage. Increase the wire gauge and the cable length when the risk of voltage drop increases. Calculate line voltage drop with this formula:

$$\text{Line voltage drop (V)} = \sqrt{3} \times \text{wire resistance } (\Omega/\text{km}) \times \text{wiring distance (m)} \times \text{motor rated current (A)} \times 10^{-3}.$$

Wire Gauge and Torque Specifications for UL Listing

⚠ WARNING *Electrical Shock Hazard. Make sure that the protective ground wire conforms to technical standards and local safety regulations. The IEC/EN 61800-5-1:2007 standard specifies that you must wire the power supply to automatically de-energize when the protective ground wire disconnects. You can also connect a protective ground wire that has a minimum cross-sectional area of 10 mm² (copper wire) or 16 mm² (aluminum wire). If you do not obey the standards and regulations, it can cause serious injury or death. The leakage current of the bypass will be more than 3.5 mA.*

Refer to the following tables for the recommended wire gauges and tightening torques of the main circuit terminals.

Note:

The recommended wire gauges are based on drive continuous current ratings with 75 °C (167 °F) 600 V class copper wire. Assume these conditions:

- Ambient temperature: 40 °C (104 °F) or lower
- Wiring distance: 100 m (3281 ft) or shorter
- Normal Duty Rated current value

208 V Enclosed Wire Gauges and Torques

Table 3.1 Input Wiring

Model F6B1	Standard Non-Fused Input Disconnect Switch S1			With Option PM Circuit Breaker CB1		
	Current Rating Amps	AWG, kcmil	Tightening Torque (in lb)	Current Rating Amps	AWG, kcmil	Tightening Torque (in lb)
D004	20	14-8	19	15	14-10 or 8-3/0	50 or 120
D007	20	14-8	19	20	14-10 or 8-3/0	50 or 120
D010	20	14-8	19	25	14-10 or 8-3/0	50 or 120
D016	20	14-8	19	40	14-10 or 8-3/0	50 or 120
D024	45	10, 8, or (6-2)	35, 40, or 50	60	14-10 or 8-3/0	50 or 120
D030	63	10, 8, or (6-2)	35, 40, or 50	70	14-10 or 8-3/0	50 or 120
D046	100	8-2/0	200	110	14-10 or 8-3/0	50 or 120
D059	100	8-2/0	200	125	14-10 or 8-3/0	50 or 120
D074	115	8-2/0	200	150	14-10 or 8-3/0	50 or 120
D088	150	14 - 10 or 8 - 3/0	50 or 120	150	14 - 10 or 8 - 3/0	50 or 120
D114	175	4 - 4/0	225	150	14 - 10 or 8 - 3/0	50 or 120
D143	250	3/0-350 kcmil	225	250	3/0 - 350 kcmil	225

Model F6B1	Standard Non-Fused Input Disconnect Switch S1			With Option PM Circuit Breaker CB1		
	Current Rating Amps	AWG, kcmil	Tightening Torque (in lb)	Current Rating Amps	AWG, kcmil	Tightening Torque (in lb)
D169	250	3/0-350 kcmil	225	250	3/0 - 350 kcmil	225
D211	400	(1-2) x (2/0-500 kcmil)	(1-2) x 442	400	(1-2) x (2/0-500 kcmil)	(1-2) x 442
D273	400	(1-2) x (2/0-500 kcmil)	(1-2) x 442	600	(1-2) x (2/0-500 kcmil)	(1-2) x 442

Table 3.2 Output and Control Wiring

Model F6B1	Motor Wiring Standard Motor Terminal Block TB1		Ground Wiring		Control Wiring							
	AWG, kcmil	Tightening Torque (in lb)	AWG, kcmil	Tightening Torque (in lb)	A1 Terminal Blocks TB1, TB3-TB6		A1 Terminal Block TB2 (FE)		A2 Terminal Blocks TB1-TB4 and TB6		Panel Terminal Block TB4	
					AWG, kcmil	Tightening Torque (in lb)	AWG, kcmil	Tightening Torque (in lb)	AWG, kcmil	Tightening Torque (in lb)	AWG, kcmil	Tightening Torque (in lb)
D004	14-2	32	14-10, 8, 6-4, or 2	35, 40, 45, or 50	24-16	4.4 to 5.3	24-18 *1	8.85 to 10.62	26-14	4	26-10	5.3 to 7.1
D007	14-2	32	14-10, 8, 6-4, or 2	35, 40, 45, or 50	24-16	4.4 to 5.3	24-18 *1	8.85 to 10.62	26-14	4	26-10	5.3 to 7.1
D010	14-2	32	14-10, 8, 6-4, or 2	35, 40, 45, or 50	24-16	4.4 to 5.3	24-18 *1	8.85 to 10.62	26-14	4	26-10	5.3 to 7.1
D016	14-2	32	14-10, 8, 6-4, or 2	35, 40, 45, or 50	24-16	4.4 to 5.3	24-18 *1	8.85 to 10.62	26-14	4	26-10	5.3 to 7.1
D024	14-2	32	14-10, 8, 6-4, or 2	35, 40, 45, or 50	24-16	4.4 to 5.3	24-18 *1	8.85 to 10.62	26-14	4	26-10	5.3 to 7.1
D030	14-2	32	14-10, 8, 6-4, or 2	35, 40, 45, or 50	24-16	4.4 to 5.3	24-18 *1	8.85 to 10.62	26-14	4	26-10	5.3 to 7.1
D046	14-2	32	14-10, 8, 6-4, or 2-1/0	35, 40, 45, or 50	24-16	4.4 to 5.3	24-18 *1	8.85 to 10.62	26-14	4	26-10	5.3 to 7.1
D059	14-2	32	14-10, 8, 6-4, or 2-1/0	35, 40, 45, or 50	24-16	4.4 to 5.3	24-18 *1	8.85 to 10.62	26-14	4	26-10	5.3 to 7.1
D074	6-2/0	120	14-10, 8, 6-4, or 2-1/0	35, 40, 45, or 50	24-16	4.4 to 5.3	24-18 *1	8.85 to 10.62	26-14	4	26-10	5.3 to 7.1
D088	14 - 8 or 6 - 2/0	50 or 120	14-10, 8, 6-4, or 2	35, 40, 45, or 50	24 - 16	4.4 to 5.3	24-18 *1	8.85 to 10.62	26 - 14	4	26-10	5.3 to 7.1
D114	14 - 10 or 8 or 6 - 2/0	35 or 40 or 120	14-10, 8, 6-4, or 2	35, 40, 45, or 50	24 - 16	4.4 to 5.3	24-18 *1	8.85 to 10.62	26 - 14	4	26-10	5.3 to 7.1
D143	6 - 350 kcmil	275	14-10, 8, 6-4, or 2	35, 40, 45, or 50	24 - 16	4.4 to 5.3	24-18 *1	8.85 to 10.62	26 - 14	4	26-10	5.3 to 7.1
D169	6 - 350 kcmil	275	14-10, 8, 6-4, or 2	35, 40, 45, or 50	24 - 16	4.4 to 5.3	24-18 *1	8.85 to 10.62	26 - 14	4	26-10	5.3 to 7.1
D211	(1-2) x (4 - 500 kcmil)	(1-2) x 500	14 - 2/0	120	24 - 16	4.4 to 5.3	24-18 *1	8.85 to 10.62	26 - 14	4	26-10	5.3 to 7.1
D273	(1-2) x (4 - 500 kcmil)	(1-2) x 500	14 - 2/0	120	24 - 16	4.4 to 5.3	24-18 *1	8.85 to 10.62	26 - 14	4	26-10	5.3 to 7.1

*1 24-16 is acceptable for solid wire or ferrule use only.

240 V Enclosed Wire Gauges and Torques

Table 3.3 Input Wiring

Model F6B1	Standard Non-Fused Input Disconnect Switch S1			With Option PM Circuit Breaker CB1		
	Current Rating Amps	AWG, kcmil	Tightening Torque (in lb)	Current Rating Amps	AWG, kcmil	Tightening Torque (in lb)
A004	20	14-8	20	15	14-10 or 8-3/0	50 or 120
A006	20	14-8	20	20	14-10 or 8-3/0	50 or 120
A009	20	14-8	20	25	14-10 or 8-3/0	50 or 120

Model F6B1	Standard Non-Fused Input Disconnect Switch S1			With Option PM Circuit Breaker CB1		
	Current Rating Amps	AWG, kcmil	Tightening Torque (in lb)	Current Rating Amps	AWG, kcmil	Tightening Torque (in lb)
A015	20	14-8	20	35	14-10 or 8-3/0	50 or 120
A022	45	10, 8, or (6-2)	35, 40, or 50	50	14-10 or 8-3/0	50 or 120
A028	63	10, 8, or (6-2)	35, 40, or 50	70	14-10 or 8-3/0	50 or 120
A042	100	8-2/0	200	100	14-10 or 8-3/0	50 or 120
A054	100	8-2/0	200	125	14-10 or 8-3/0	50 or 120
A068	100	8-2/0	200	150	14-10 or 8-3/0	50 or 120
A080	115	8-2/0	200	150	14-10 or 8-3/0	50 or 120
A104	175	4-4/0	225	150	14-10 or 8-3/0	50 or 120
A130	250	3/0-350 kcmil	225	250	4-4/0	225
A154	250	3/0-350 kcmil	225	250	3/0-350	225
A192	250	3/0-350 kcmil	225	400	(1-2) x (2/0-500 kcmil)	(1-2) x 442
A248	400	(1-2) x (2/0-500 kcmil)	(1-2) x 442	600	(1-2) x (2/0-500 kcmil)	(1-2) x 442

Table 3.4 Output and Control Wiring

Model F6B1	Motor Wiring Standard Motor Terminal Block TB1		Ground Wiring		Control Wiring							
	AWG, kcmil	Tightening Torque (in lb)	AWG, kcmil	Tightening Torque (in lb)	A1 Terminal Blocks TB1, TB3-TB6		A1 Terminal Block TB2 (FE)		A2 Terminal Blocks TB1-TB4 and TB6		Panel Terminal Block TB4	
					AWG, kcmil	Tightening Torque (in lb)	AWG, kcmil	Tightening Torque (in lb)	AWG, kcmil	Tightening Torque (in lb)	AWG, kcmil	Tightening Torque (in lb)
A004	14-2	32	14-10, 8, 6-4, or 2	35, 40, 45, or 50	24-16	4.4 to 5.3	24-18 *	8.85 to 10.62	26-14	4	26-10	5.3 to 7.1
A006	14-2	32	14-10, 8, 6-4, or 2	35, 40, 45, or 50	24-16	4.4 to 5.3	24-18 *	8.85 to 10.62	26-14	4	26-10	5.3 to 7.1
A009	14-2	32	14-10, 8, 6-4, or 2	35, 40, 45, or 50	24-16	4.4 to 5.3	24-18 *	8.85 to 10.62	26-14	4	26-10	5.3 to 7.1
A015	14-2	32	14-10, 8, 6-4, or 2	35, 40, 45, or 50	24-16	4.4 to 5.3	24-18 *	8.85 to 10.62	26-14	4	26-10	5.3 to 7.1
A022	14-2	32	14-10, 8, 6-4, or 2	35, 40, 45, or 50	24-16	4.4 to 5.3	24-18 *	8.85 to 10.62	26-14	4	26-10	5.3 to 7.1
A028	14-2	32	14-10, 8, 6-4, or 2	35, 40, 45, or 50	24-16	4.4 to 5.3	24-18 *	8.85 to 10.62	26-14	4	26-10	5.3 to 7.1
A042	14-2	32	14-10, 8, 6-4, or 2	35, 40, 45, or 50	24-16	4.4 to 5.3	24-18 *	8.85 to 10.62	26-14	4	26-10	5.3 to 7.1
A054	14-2	32	14-10, 8, 6-4, or 2	35, 40, 45, or 50	24-16	4.4 to 5.3	24-18 *	8.85 to 10.62	26-14	4	26-10	5.3 to 7.1
A068	14-2	32	14-10, 8, 6-4, or 2	35, 40, 45, or 50	24-16	4.4 to 5.3	24-18 *	8.85 to 10.62	26-14	4	26-10	5.3 to 7.1
A080	14-8 or 6-2/0	50 or 120	14-10, 8, 6-4, or 2	35, 40, 45, or 50	24-16	4.4 to 5.3	24-18 *	8.85 to 10.62	26-14	4	26-10	5.3 to 7.1
A104	14-8 or 6-2/0	50 or 120	14-10, 8, 6-4, or 2	35, 40, 45, or 50	24-16	4.4 to 5.3	24-18 *	8.85 to 10.62	26-14	4	26-10	5.3 to 7.1
A130	(1-2) x (6 or 4) or (3-4/0)	(1-2) x 80 or 100 or 150	14-10, 8, 6-4, or 2	35, 40, 45, or 50	24-16	4.4 to 5.3	24-18 *	8.85 to 10.62	26-14	4	26-10	5.3 to 7.1
A154	6 - 350 kcmil	275	14-10, 8, 6-4, or 2	35, 40, 45, or 50	24-16	4.4 to 5.3	24-18 *	8.85 to 10.62	26-14	4	26-10	5.3 to 7.1
A192	6-350 kcmil	275	14 - 2/0	120	24-16	4.4 to 5.3	24-18 *	8.85 to 10.62	26-14	4	26-10	5.3 to 7.1
A248	(1-2) x (4-500 kcmil)	(1-2) x 500	14 - 2/0	120	24-16	4.4 to 5.3	24-18 *	8.85 to 10.62	26-14	4	26-10	5.3 to 7.1

*1 24-16 is acceptable for solid wire or ferrule use only.

480 V Enclosed Wire Gauges and Torques

Table 3.5 Input Wiring

Model F6B1	Standard Non-Fused Input Disconnect Switch S1			With Option PM Circuit Breaker CB1		
	Current Rating Amps	AWG, kcmil	Tightening Torque (in lb)	Current Rating Amps	AWG, kcmil	Tightening Torque (in lb)
B002	20	14-8	20	15	(14-10) or (8-3/0)	50 or 120
B003	20	14-8	20	15	(14-10) or (8-3/0)	50 or 120
B004	20	14-8	20	15	(14-10) or (8-3/0)	50 or 120
B007	20	14-8	20	20	(14-10) or (8-3/0)	50 or 120
B011	20	14-8	20	25	(14-10) or (8-3/0)	50 or 120
B014	20	14-8	20	35	(14-10) or (8-3/0)	50 or 120
B021	45	10, 8 or (6-2)	35, 40, or 50	50	(14-10) or (8-3/0)	50 or 120
B027	45	10, 8 or (6-2)	35, 40, or 50	60	(14-10) or (8-3/0)	50 or 120
B034	63	10, 8 or (6-2)	35, 40, or 50	70	(14-10) or (8-3/0)	50 or 120
B040	63	10, 8 or (6-2)	35, 40, or 50	80	(14-10) or (8-3/0)	50 or 120
B052	100	8-2/0	200	110	(14-10) or (8-3/0)	50 or 120
B065	100	8-2/0	200	115	(14-10) or (8-3/0)	50 or 120
B077	150	8-3/0	120	150	(14-10) or (8-3/0)	50 or 120
B096	150	14-10 or 8-3/0	50 or 120	150	(14-10) or (8-3/0)	50 or 120
B124	175	4 - 4/0	225	250	4-4/0	225
B156	250	3/0-350 kcmil	225	250	3/0-350 kcmil	225
B180	250	3/0-350 kcmil	225	250	3/0-350 kcmil	225
B240	400	(1-2) x (2/0-500 kcmil)	(1-2) x 442	500	(1-2) x (2/0-500 kcmil)	(1-2) x 442
B302	600	(1-2) x (2/0-500 kcmil)	(1-2) x 442	600	(1-2) x (2/0-500 kcmil)	(1-2) x 442

Table 3.6 Output and Control Wiring

Model F6B1	Motor Wiring Standard Motor Terminal Block TB1		Ground Wiring		Control Wiring							
	AWG, kcmil	Tightening Torque (in lb)	AWG, kcmil	Tightening Torque (in lb)	A1 Terminal Blocks TB1, TB3-TB6		A1 Terminal Block TB2 (FE)		A2 Terminal Blocks TB1-TB4 and TB6		Panel Terminal Block TB4	
					AWG, kcmil	Tightening Torque (in lb)	AWG, kcmil	Tightening Torque (in lb)	AWG, kcmil	Tightening Torque (in lb)	AWG, kcmil	Tightening Torque (in lb)
B002	14-2	32	14-10, 8, 6-4, or 2	35, 40, 45, or 50	24-16	4.4 to 5.3	24-18 ^{*1}	8.85 to 10.62	26-14	4	26-10	5.3 to 7.1
B003	14-2	32	14-10, 8, 6-4, or 2	35, 40, 45, or 50	24-16	4.4 to 5.3	24-18 ^{*1}	8.85 to 10.62	26-14	4	26-10	5.3 to 7.1
B004	14-2	32	14-10, 8, 6-4, or 2	35, 40, 45, or 50	24-16	4.4 to 5.3	24-18 ^{*1}	8.85 to 10.62	26-14	4	26-10	5.3 to 7.1
B007	14-2	32	14-10, 8, 6-4, or 2	35, 40, 45, or 50	24-16	4.4 to 5.3	24-18 ^{*1}	8.85 to 10.62	26-14	4	26-10	5.3 to 7.1
B011	14-2	32	14-10, 8, 6-4, or 2	35, 40, 45, or 50	24-16	4.4 to 5.3	24-18 ^{*1}	8.85 to 10.62	26-14	4	26-10	5.3 to 7.1
B014	14-2	32	14-10, 8, 6-4, or 2	35, 40, 45, or 50	24-16	4.4 to 5.3	24-18 ^{*1}	8.85 to 10.62	26-14	4	26-10	5.3 to 7.1
B021	14-2	32	14-10, 8, 6-4, or 2	35, 40, 45, or 50	24-16	4.4 to 5.3	24-18 ^{*1}	8.85 to 10.62	26-14	4	26-10	5.3 to 7.1
B027	14-2	32	14-10, 8, 6-4, or 2	35, 40, 45, or 50	24-16	4.4 to 5.3	24-18 ^{*1}	8.85 to 10.62	26-14	4	26-10	5.3 to 7.1

Model F6B1	Motor Wiring Standard Motor Terminal Block TB1		Ground Wiring		Control Wiring							
	AWG, kcmil	Tightening Torque (in lb)	AWG, kcmil	Tightening Torque (in lb)	A1 Terminal Blocks TB1, TB3-TB6		A1 Terminal Block TB2 (FE)		A2 Terminal Blocks TB1-TB4 and TB6		Panel Terminal Block TB4	
					AWG, kcmil	Tightening Torque (in lb)	AWG, kcmil	Tightening Torque (in lb)	AWG, kcmil	Tightening Torque (in lb)	AWG, kcmil	Tightening Torque (in lb)
B034	14-2	32	14-10, 8, 6-4, or 2-1/0	35, 40, 45, or 50	24-16	4.4 to 5.3	24-18 *1	8.85 to 10.62	26-14	4	26-10	5.3 to 7.1
B040	14-2	32	14-10, 8, 6-4, or 2-1/0	35, 40, 45, or 50	24-16	4.4 to 5.3	24-18 *1	8.85 to 10.62	26-14	4	26-10	5.3 to 7.1
B052	14-2	32	14-10, 8, 6-4, or 2-1/0	35, 40, 45, or 50	24-16	4.4 to 5.3	24-18 *1	8.85 to 10.62	26-14	4	26-10	5.3 to 7.1
B065	14-2	32	14-10, 8, 6-4, or 2-1/0	35, 40, 45, or 50	24-16	4.4 to 5.3	24-18 *1	8.85 to 10.62	26-14	4	26-10	5.3 to 7.1
B077	6-2/0	120	14-10, 8, 6-4, or 2-1/0	35, 40, 45, or 50	24-16	4.4 to 5.3	24-18 *1	8.85 to 10.62	26-14	4	26-10	5.3 to 7.1
B096	14 - 8 or 6 - 2/0	50 or 120	14-10, 8, 6-4, or 2	35, 40, 45, or 50	24-16	4.4 to 5.3	24-18 *1	8.85 to 10.62	26 - 14	4	26-10	5.3 to 7.1
B124	(1-2) x (6) or (4) or (3 - 4/ 0)	(1-2) x 80 or 100 or 150	14-10, 8, 6-4, or 2	35, 40, 45, or 50	24-16	4.4 to 5.3	24-18 *1	8.85 to 10.62	26 - 14	4	26-10	5.3 to 7.1
B156	6 - 350 kcmil	275	14-10, 8, 6-4, or 2	35, 40, 45, or 50	24-16	4.4 to 5.3	24-18 *1	8.85 to 10.62	26 - 14	4	26-10	5.3 to 7.1
B180	6 - 350 kcmil	275	14 - 2/0	120	24-16	4.4 to 5.3	24-18 *1	8.85 to 10.62	26 - 14	4	26-10	5.3 to 7.1
B240	(1-2) x (4 - 500 kcmil)	(1-2) x 500	14 - 2/0	120	24-16	4.4 to 5.3	24-18 *1	8.85 to 10.62	26 - 14	4	26-10	5.3 to 7.1
B302	(1-2) x (4 - 500 kcmil)	(1-2) x 500	14 - 2/0	120	24-16	4.4 to 5.3	24-18 *1	8.85 to 10.62	26 - 14	4	26-10	5.3 to 7.1

*1 24-16 is acceptable for solid wire or ferrule use only.

■ Main Circuit Terminal and Motor Wiring

This section outlines the various steps, precautions, and checkpoints to wire the main circuit terminals and motor terminals.

⚠ WARNING *Sudden Movement Hazard. Make sure that you align the phase order for the bypass and motor when you connect the motor to output terminals TB1-1, TB1-2, and TB1-3. If the phase order is incorrect, it can cause the motor to run in reverse. If the motor accidentally runs in reverse, it can cause serious injury or death.*

NOTICE *Do not connect phase-advancing capacitors, LC/RC noise filters, or leakage breakers (GFCI) to the motor circuit. If you connect these devices to the output circuits, it can cause damage to the bypass and connected equipment.*

Cable Length Between Bypass and Motor

When the wiring between the bypass and the motor is too long, voltage drop along the motor cable can decrease motor torque, usually at low frequency output. If you use a long motor cable to connect motors in parallel, this is also a problem. Output current increases when the leakage current from the cable increases. An increase in leakage current can cause overcurrent and decrease the precision of current detection.

If the system configuration makes the motor wiring distance more than 100 m (328 ft), do not use metal conduits or use isolated cables for each phase to decrease stray capacitance.

Table 3.7 Carrier Frequency against Cable Length Between Drive and Motor

Wiring Distance between the Bypass and Motor	100 m (328 ft) Maximum
Carrier Frequency	2 kHz or less

Note:

- For bypass models D004 to D016, A004 to A015, and B002 to B014:
 - Shorter than 10 m: No carrier frequency derating from default setting (5 kHz) is necessary.
 - 10 m to 50 m: 5 kHz to 2 kHz is necessary.
 - 50 m and longer: 2 kHz
- To set the carrier frequency in a bypass that is operating more than one motor, calculate the cable length as the total distance of wiring to all connected motors.

Ground Wiring

Follow these precautions to wire the ground for one bypass or a series of bypasses.

⚠ WARNING *Electrical Shock Hazard. Make sure that the protective ground wire conforms to technical standards and local safety regulations. The IEC/EN 61800-5-1:2007 standard specifies that you must wire the power supply to automatically de-energize when the protective ground wire disconnects. You can also connect a protective ground wire that has a minimum cross-sectional area of 10 mm² (copper wire) or 16 mm² (aluminum wire). If you do not obey the standards and regulations, it can cause serious injury or death. The leakage current of the bypass will be more than 3.5 mA.*

⚠ WARNING *Electrical Shock Hazard. Ground the neutral point on the power supply of the bypass to comply with the EMC Directive before you turn on the EMC filter. If you turn ON the EMC filter, but you do not ground the neutral point, it can cause serious injury or death.*

⚠ WARNING *Electrical Shock Hazard. Use a ground wire that complies with technical standards on electrical equipment and use the minimum length of ground wire. Incorrect equipment grounding can cause serious injury or death from dangerous electrical potentials on the equipment chassis.*

Note:

- Only use the bypass grounding wire to ground the bypass. Do not share the ground wire with other devices, for example, welding machines or large-current electrical equipment. Incorrect equipment grounding can cause incorrect operation of equipment.
- To connect more than one bypass to the same grounding circuit, use the instructions in the manual. Incorrect equipment grounding can cause incorrect operation of equipment.

When you install more than one bypass, refer to [Figure 3.3](#). Do not loop the grounding wire.

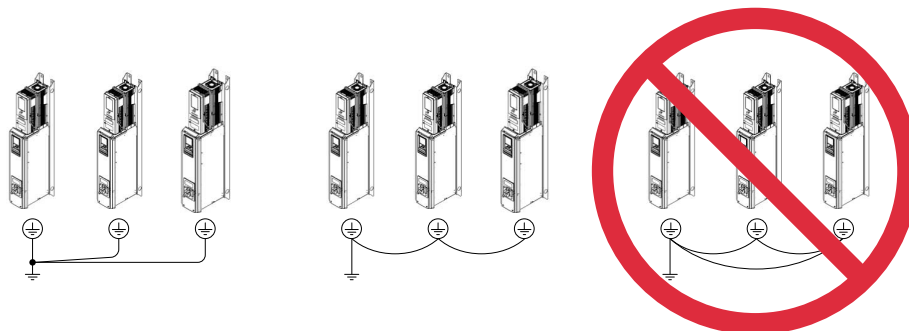

Figure 3.3 Wiring More than One Bypass

Wiring the Main Circuit Terminal Block

⚠ WARNING *Electrical Shock Hazard. Before you wire the main circuit terminals, make sure that MCCB and MC are OFF. If you touch electrical equipment when MCCB and MC are ON, it can cause serious injury or death.*

■ Protection of Main Circuit Terminals

When you wire the main circuit terminals, do not let cable ends go near terminals or the drive. If you use crimped terminals, make sure that you also use insulation caps.

◆ Main Circuit Terminal Wiring Procedure

⚠ DANGER *Electrical Shock Hazard. Do not examine, connect, or disconnect wiring on an energized bypass. Before servicing, disconnect all power to the equipment and wait for the time specified on the warning label at a minimum. The internal capacitor stays charged after the bypass is de-energized. The charge indicator LED extinguishes when the DC bus voltage decreases below 50 VDC. When all indicators are OFF, remove the covers before measuring for dangerous voltages to make sure that the bypass is safe. If you do work on the bypass when it is energized, it will cause serious injury or death from electrical shock.*

■ Notes on Wiring the Main Circuit Terminal

Read these safety messages and notes before you wire the main circuit terminal.

⚠ WARNING *Fire Hazard. Do not use bent or crushed wires. Remove the damaged end of the wire before you use it. Incorrect connections can cause death or serious injury from fire.*

⚠ WARNING *Fire Hazard. If you use stranded wire, make sure that all of the wire strands are in the connection. Also, do not twist the stranded wire too much. Incorrect connections can cause death or serious injury from fire.*

NOTICE *Do not solder stranded wire. Soldered wire connections can become loose over time and cause unsatisfactory drive performance.*

NOTICE *If you use power tools to tighten the terminal screws, use a low speed setting (300 min⁻¹ (r/min) to 400 min⁻¹ (r/min)). High speeds can cause damage to the terminal screws.*

Note:

- Use UL Listed vinyl-coated insulated copper wires for operation with a continuous maximum permitted temperature of 75 °C at 600 V.
- Remove all unwanted objects that are near the terminal block connections.
- Remove the insulation from the connection wires to the wire stripping lengths shown in the manual.
- Put the wire all the way into the terminal block. Remove the insulation from the wire to the recommended wire stripping length to fit the wire with insulation in the plastic housing.
- Use a torque driver, torque ratchet, or torque wrench for the screws. A slotted driver or a hex tool will be necessary to wire the screw clamp terminal. Use applicable tools as specified by the recommended conditions in the product manual.
- Put the bit all the way into the hex socket to tighten the hex socket cap screw.
- When tightening slotted screws, hold the straight-edge screwdriver perpendicularly to the screw. Take care to ensure that the tip of the straight-edge screwdriver is aligned with the screw groove.

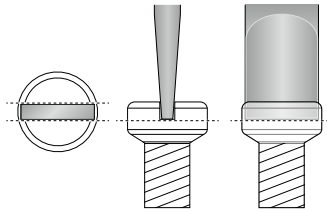
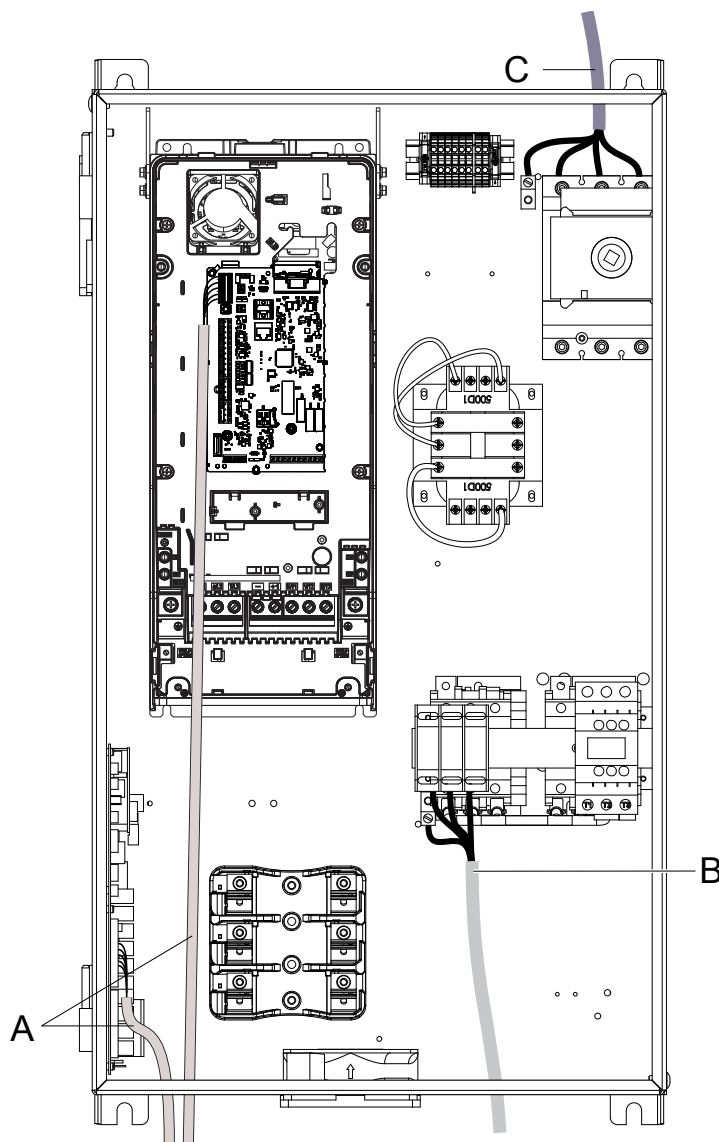

Figure 3.4 Tightening Slotted Screws

- After connecting the wires to the terminal block, lightly pull on the wires to make sure that they do not come out of the terminals.

■ Enclosed Bypass Main Circuit Terminal Block Wiring Procedure

1. Correctly ground the bypass terminal board.
2. Route the main circuit wiring. [Figure 3.5](#) shows suggested wire entry and bending areas for the enclosure.



A - Optional drive control wiring
B - Motor output circuit

C - Main input circuit

Figure 3.5 Enclosed Bypass Wire Routing Example (Models F6B1D004 to D273, A004 to A248, and B002 to B302)

◆ Bypass Controller

Note:

When possible, use these control terminal connections on the bypass controller. There are additional control I/O terminals available on the drive, however those terminals are active in Drive Mode ONLY and may not report correctly in Bypass Mode.

■ Control Circuit Terminal Arrangement

The bypass control circuit terminals are in the positions shown in [Figure 3.6](#).

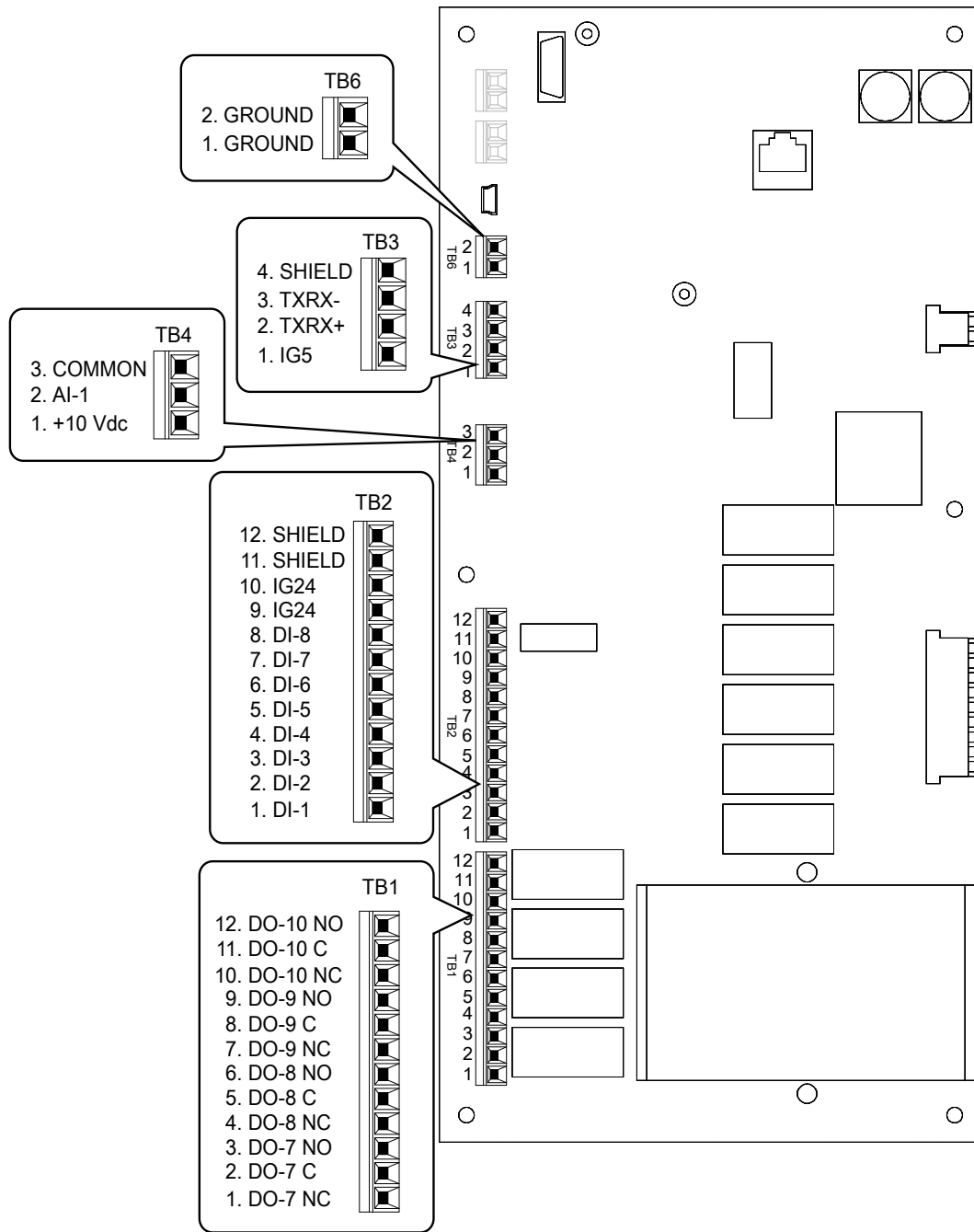

Figure 3.6 Bypass Control Circuit Terminal Arrangement

■ Bypass Control Circuit Wire Gauges and Tightening Torques

Use the tables in this section to select the correct wires. Use shielded wire to wire the control circuit terminal block. Use crimp ferrules on the wire ends to make the wiring procedure easier and more reliable.

Table 3.8 Bypass Control Circuit Wire Gauges and Tightening Torques

Bypass Terminal Block	Terminal	Tightening Torque in-lb	Recommended Gauge AWG	Applicable Gauge AWG
TB1	DO-7 - DO-10	4	18	26-14
TB2	DI-1 - DI-8, IG24, SHIELD			
TB3	SHEILD, TXRX-, TXRX+, IG5			
TB4	+10 VDC, AI-1, COMMON			
TB6	GROUND, GROUND			

■ Crimp Ferrules

Attach an insulated sleeve when you use crimp ferrules. Refer to [Table 3.9](#) for the recommended external dimensions and model numbers of the crimp ferrules.

Use the CRIMPFOX 6, a crimping tool made by PHOENIX CONTACT.

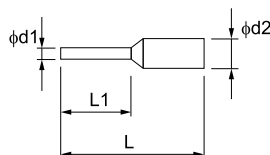
**Figure 3.7 External Dimensions of Crimp Ferrules****Table 3.9 Crimp Ferrule Models and Sizes**

Wire Gauge mm ² (AWG)	Model	L (mm)	L1 (mm)	φd1 (mm)	φd2 (mm)
0.25 (24)	AI 0.25-8YE	12.5	8	0.8	2.0
0.34 (22)	AI 0.34-8TQ	12.5	8	0.8	2.0
0.5 (20)	AI 0.5-8WH AI 0.5-8OG	14	8	1.1	2.5
0.75 (18)	AI 0.75-8 GY	14	8	1.3	2.8

■ Bypass Control Circuit Terminal Block Input Functions

⚠ WARNING *Sudden Movement Hazard. Correctly wire and test all control circuits to make sure that the control circuits operate correctly. If you use a drive that has incorrect control circuit wiring or operation, it can cause death or serious injury.*

NOTICE *Damage to Equipment. Do not energize and de-energize the bypass more frequently than one time each 30 minutes. If you frequently energize and de-energize the bypass, it can cause failure.*

Table 3.10 Bypass Digital Input Terminals (TB2)

Type	Terminal	Name (Default)	Function (Signal Level)
Digital Inputs	TB2-1 DI-1	Digital Input 1 (Run (AUTO))	Dry contact rated, photocoupler sinking input to IG24, 24 VDC 8 mA, Ground fault protected
	TB2-2 DI-2	Digital Input 2 (Run Enable - Safety (NC))	
	TB2-3 DI-3	Digital Input 3 (Run Interlock (BAS))	
	TB2-4 DI-4	Digital Input 4 (Remote Transfer to Bypass)	
	TB2-5 DI-5	Digital Input 5 (Emergency Override Bypass)	
	TB2-6 DI-6	Digital Input 6 (Not used)	
	TB2-7 DI-7	Digital Input 7 (Not used)	
	TB2-8 DI-8	Digital Input 8 (Not used)	
	TB2-9/10 IG24	Isolated Ground	Digital input common

Table 3.11 Bypass Analog Input Terminals (TB4)

Type	Terminal	Name (Default)	Function (Signal Level)
Analog Input	TB4-1 +10 VDC	Analog Input Power Supply	AUTO Mode Speed Reference 0 to 10 VDC (20 kΩ) or 4 to 20 mA (250 Ω)
	TB4-2 AI	Analog Input Speed Reference	
	TB4-3 COMMON	Analog Input Common	

■ **Bypass Control Circuit Terminal Block Output Functions**

Table 3.12 Bypass Digital Output Terminals (TB1)

Type	Terminal	Name (Default)	Function (Signal Level)
Digital Outputs	TB1-1/2/3 DO-7	Digital Output 7 (Run Active)	Relay, dry contact form C, 30 VDC or 120 Vac, DO-7 to DO-10 for customer use, 2 Amp
	TB1-4/5/6 DO-8	Digital Output 8 (HAND mode Active)	
	TB1-7/8/9 DO-9	Digital Output 9 (AUTO mode Active)	
	TB1-10/11/ 12 DO-10	Digital Output 10 (Fault Active)	

Table 3.13 Control Circuit Ground Terminals (TB6)

Type	Terminal	Name (Default)	Function (Signal Level)
Ground	TB6-1/2 GROUND	Chassis Ground	-

■ Bypass Serial Communication Terminals

Table 3.14 Bypass Serial Communication Terminals (TB3)

Type	Terminal	Terminal Name	Function (Signal Level)
Serial Communication	TB3-1 IG5	Isolated ground	Ground reference for RS-485 signals. This is an isolated ground used only for communications and may be used in certain circumstances to connect the floating ground references of other communication devices.
	TB3-2 TXRX+	(+) Differential communication signal	<ul style="list-style-type: none"> • BACnet communications • APOGEE FLN communications • MEMOBUS/ Modbus communications • Metasys N2 communications Use an RS-485 cable to connect the drive. Note: Make sure that DIP switch S1 is ON to enable the termination resistor in the last drive in a BACnet, APOGEE FLN, MEMOBUS/ Modbus, or Metasys N2 network.
	TB3-3 TXRX-	(-) Differential communication signal	
	TB3-4 SHIELD	Shield tie point	Capacitively coupled to chassis ground.

■ Switches on the Bypass Controller

The bypass controller has switches to adapt the bypass I/Os to the external control signals as shown in [Figure 3.8](#). Set the switches to select the functions for each terminal.

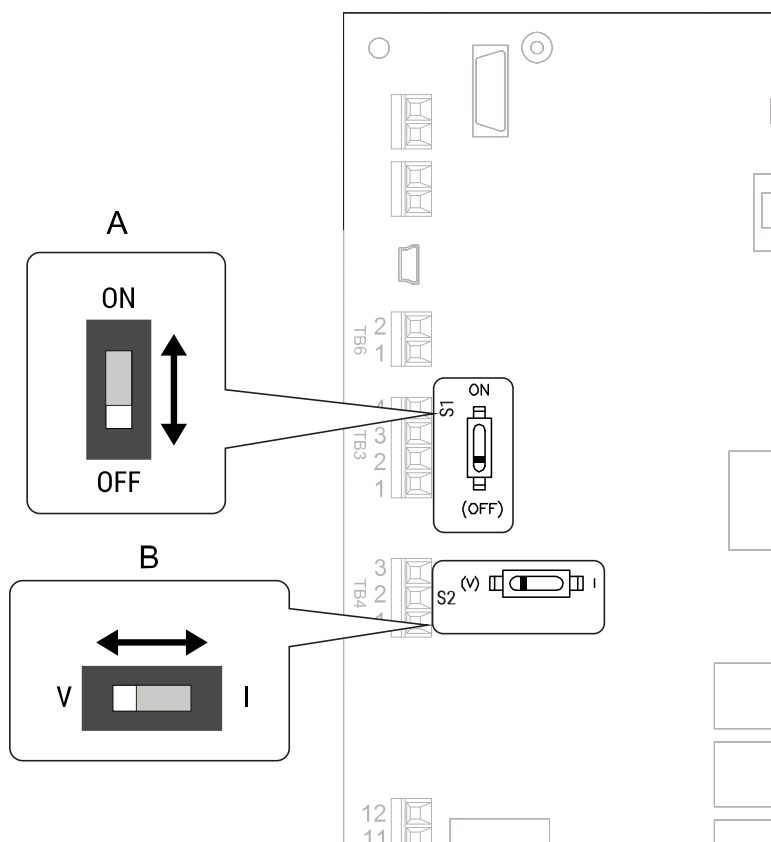

Figure 3.8 Locations of Switches

Table 3.15 I/O Switch Functions

Position	Switch	Function	Default Setting
A	DIP switch S1	RS-485 Terminating Resistor (120 Ω) enables and disables the termination resistor of these communications: <ul style="list-style-type: none"> • BACnet (MSTP) • APOGEE FLN • MEMOBUS/Modbus • Metasys N2 	OFF
B	DIP switch S2	V/I switch for analog input.	V (voltage input) I (current input)

■ Wiring the Bypass Control Circuit Terminal

⚠ WARNING *Electrical Shock Hazard. Do not remove covers or touch circuit boards while the bypass is energized. If you touch the internal components of an energized bypass, it can cause serious injury or death.*

NOTICE *Do not let wire shields touch other signal lines or equipment. Insulate the wire shields with electrical tape or shrink tubing. If you do not insulate the wire shields, it can cause a short circuit and damage the drive.*

Note:

- Isolate control circuit wiring from main circuit wiring and other high-power wiring. If the control circuit wires are adjacent to the main circuit wires, electrical interference can cause the bypass or the devices around the bypass to malfunction.
- Isolate TB1 contact output terminals from other control circuit wiring. If the output terminal wires are adjacent to other control circuit wires, electrical interference can cause the bypass or devices around the bypass to malfunction.
- Use a UL Listed Class 2 Power Supply to connect external power to the TB1 contact output control terminals. If the power supply for peripheral devices is incorrect, it can cause a decrease in bypass performance.
- Connect the shield of shielded cable to the applicable ground or shield terminal. If the shield connections are not correct, electrical interference can cause the bypass or devices around the bypass to malfunction.

Correctly ground the bypass terminals and complete main circuit wiring before you wire the control circuit. Remove the front cover.

1. Refer to [Figure 3.9](#) and wire the control circuit.

⚠ WARNING *Fire Hazard. Tighten all terminal screws to the correct tightening torque. Connections that are too loose or too tight can cause incorrect operation and damage to the bypass. Incorrect connections can also cause death or serious injury from fire.*

Note:

- Use shielded wires and shielded twisted-pair wires for the control circuit terminal wiring. If the grounding is not correct, electrical interference can cause the drive or devices around it to malfunction.
- Do not use control circuit wiring that is longer than 50 m (164 ft) to supply the frequency reference with an analog signal from a remote source. Wiring that is too long can cause unsatisfactory system performance.

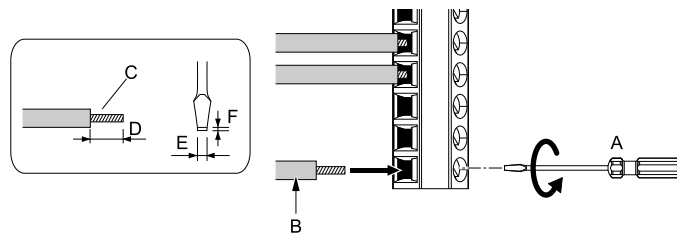

- A** - Loosen the screws and put the wire into the opening on the terminal block.
- B** - Wire with a crimp ferrule attached, or use wire that is not soldered with the core wires lightly twisted.
- C** - Pull back the shielding and lightly twist the end with your fingers to keep the ends from fraying.
- D** - If you do not use crimp ferrules, remove approximately 5.5 mm (0.21 in) of the covering at the end of the wire.
- E** - Blade width of 2.5 mm (0.1 in) or less
- F** - Blade depth of 0.4 mm (0.01 in) or less

Figure 3.9 Wiring Procedure for the Control Circuit

⚠ WARNING *Fire Hazard. Tighten all terminal screws to the correct tightening torque. Connections that are too loose or too tight can cause incorrect operation and damage to the bypass. Incorrect connections can also cause death or serious injury from fire.*

NOTICE *Do not tin stranded wire with solder. Soldered wire connections can become loose over time and cause unsatisfactory system performance.*

Note:

- Refer to [Figure 3.10](#) for information to prepare terminal ends of the shielded wire.
- Prepare the wire ends of shielded twisted-pair wires as shown in [Figure 3.10](#) to use an analog reference from an external frequency setting potentiometer to set the frequency. Connect the shield to TB2-11 or TB2-12 on the bypass control board or terminal FE on the drive.

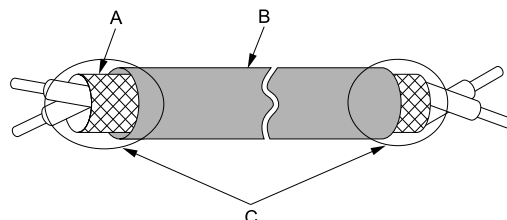

A - Connect the shield to TB2-11 or TB2-12.

C - Insulate with electrical tape or shrink tubing.

B - Sheath

Figure 3.10 Prepare the Ends of Shielded Wire

2. Install the front cover to its initial position.

◆ Drive Control Circuit

Note:

When possible, use the control terminal connections on the Bypass PCB. The additional control I/O terminals available on the Drive Control circuit, are active in Drive Mode ONLY and may not report correctly in Bypass Mode. Typically, the Drive Control circuit wiring is used with a PID feedback signal or an analog monitor (output). In most applications, you should not connect to the drive control circuit digital inputs (S1 to S8) because it can cause unintended operation.

■ Drive Control Circuit Terminal Arrangement

The drive control circuit terminals are in the positions shown in [Figure 3.11](#).

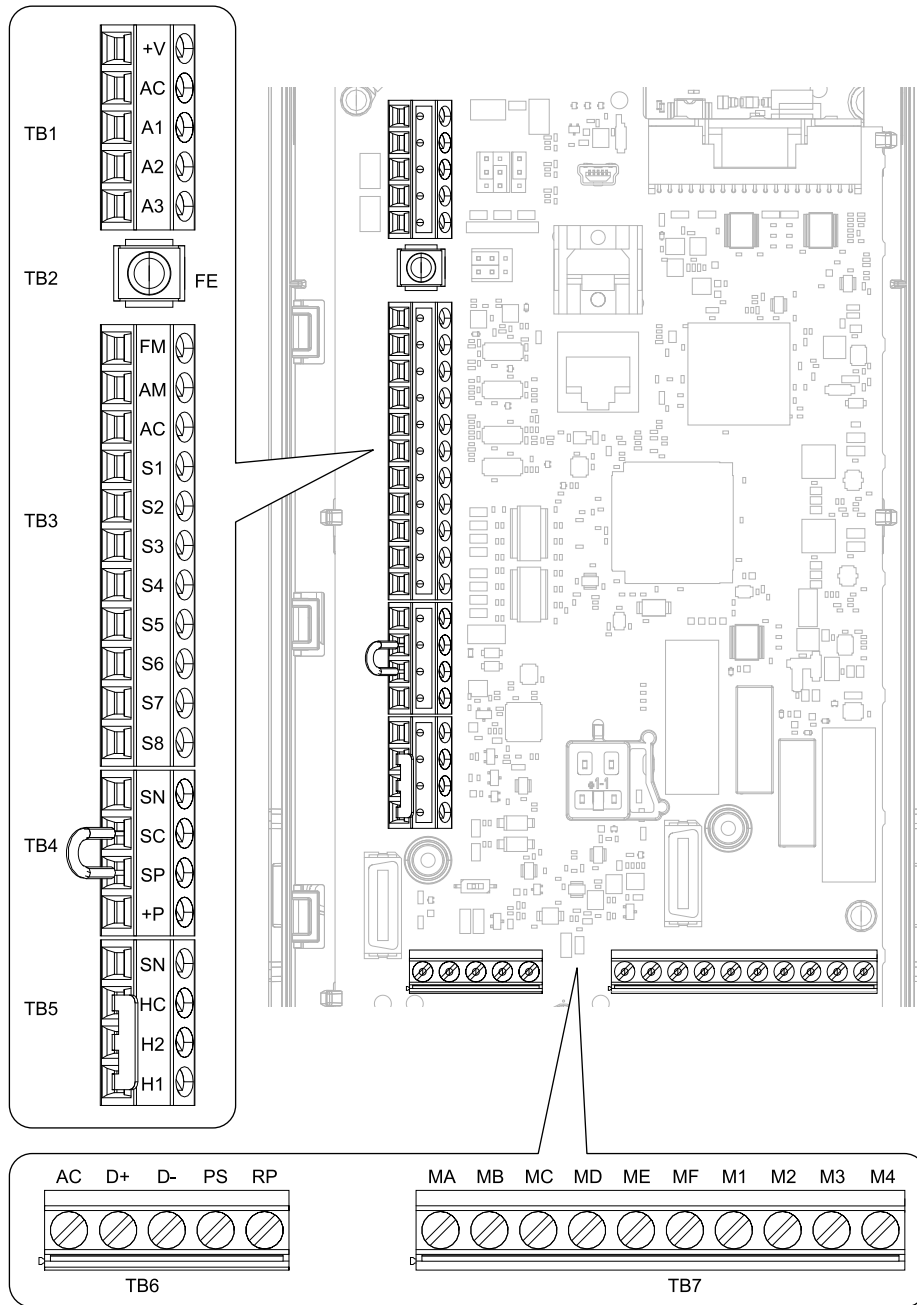

Figure 3.11 Control Circuit Terminal Arrangement

The tightening torque for the drive terminal screws is shown on the reverse side or the lower front side of the drive front cover.

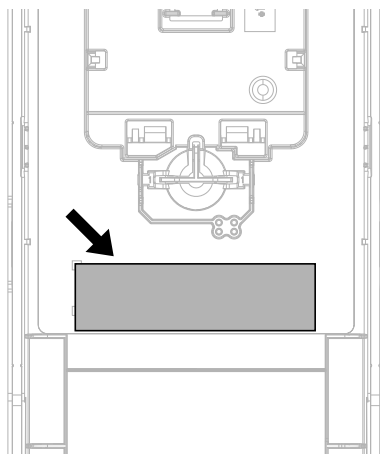

Figure 3.12 Tightening Torque Display Location (Reverse Side of Drive Front Cover)

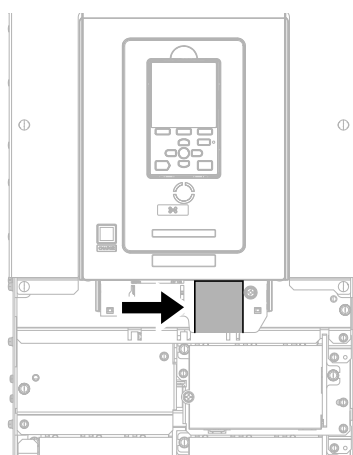

Figure 3.13 Tightening Torque Display Location (Lower Front Side of Drive Front Cover)

■ Drive Control Circuit Wire Gauges and Tightening Torques

Use the tables in this section to select the correct wires. Use shielded wire to wire the control circuit terminal block. Use crimp ferrules on the wire ends to make the wiring procedure easier and more reliable.

Table 3.16 Drive Control Circuit Wire Gauges and Tightening Torques

Terminal Block	Terminal	Screw Size	Tightening Torque N·m (lbf·in)	Bare Wire		Crimp Ferrule	
				Recommended Gauge mm ² (AWG)	Applicable Gauge mm ² (AWG)	Recommended Gauge mm ² (AWG)	Applicable Gauge mm ² (AWG)
TB1	+V, AC, A1, A2, A3	M3	0.5 - 0.6 (4.4 - 5.3)	0.75 (18)	Stranded wire: 0.25 - 1.5 (24 - 16) Solid wire: 0.25 - 1.5 (24 - 16)	0.75 (18)	0.25 - 1.5 (24 - 16)
TB3	FM, AM, AC, S1 - S8						
TB4	SN, SC, SP, +P						
TB5	SN, HC, H1, H2						
TB6	AC, D+, D-, PS, RP						
TB7	MA, MB, MC, MD, ME, MF, M1 - M4						
TB2	FE		1.0 - 1.2 (8.85 - 10.62)	0.75 (18)	Stranded wire: 0.12 - 0.75 (26 - 18) Solid wire: 0.2 - 1.5 (26 - 16)	0.75 (18)	0.25 - 1.5 (24 - 16)

■ Crimp Ferrules

Attach an insulated sleeve when you use crimp ferrules. Refer to [Table 3.17](#) for the recommended external dimensions and model numbers of the crimp ferrules.

Use the CRIMPFOX 6, a crimping tool made by PHOENIX CONTACT.

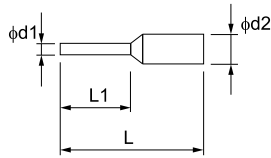

Figure 3.14 External Dimensions of Crimp Ferrules

Table 3.17 Crimp Ferrule Models and Sizes

Wire Gauge mm ² (AWG)	Model	L (mm)	L1 (mm)	φd1 (mm)	φd2 (mm)
0.25 (24)	AI 0.25-8YE	12.5	8	0.8	2.0
0.34 (22)	AI 0.34-8TQ	12.5	8	0.8	2.0
0.5 (20)	AI 0.5-8WH AI 0.5-8OG	14	8	1.1	2.5
0.75 (18)	AI 0.75-8 GY	14	8	1.3	2.8

■ Drive Control Circuit Terminal Block Input Functions

Hx-xx parameters set functions for the multi-function input and output terminals.

NOTICE *Damage to Equipment. Do not energize and de-energize the bypass more frequently than one time each 30 minutes. If you frequently energize and de-energize the bypass, it can cause failure.*

Refer to [Table 3.18](#) for a list of input terminals and functions on the drive.

Table 3.18 Drive Multi-function Input Terminals

Type	Terminal	Name (Default)	Function (Signal Level)
MFDI	S1	MFDI selection 1 (ON: Forward RUN (2-Wire) OFF: Stop)	<p>Note: Connections to these inputs can cause unintended operation. Use the Bypass PCB digital inputs. Multi-Function Digital Input</p> <ul style="list-style-type: none"> • Photocoupler • 24 V, 6 mA <p>Note: Install the wire jumpers between terminals SC-SP and SC-SN to set the MFDI power supply (sinking/sourcing mode or internal/external power supply). • Sinking Mode: Install a jumper between terminals SC and SP.</p> <p>NOTICE <i>Damage to Equipment. Do not close the circuit between terminals SC-SN. If you close the circuits between terminals SC-SP and terminals SC-SN at the same time, it will cause damage to the drive.</i></p> <ul style="list-style-type: none"> • Sourcing Mode: Install a jumper between terminals SC and SN. <p>NOTICE <i>Damage to Equipment. Do not close the circuit between terminals SC-SP. If you close the circuits between terminals SC-SP and terminals SC-SN at the same time, it will cause damage to the drive.</i></p> <ul style="list-style-type: none"> • External power supply: No jumper necessary between terminals SC-SN and terminals SC-SP.
	S2	MFDI selection 2 (ON: Reverse RUN (2-Wire) OFF: Stop)	
	S3	MFDI selection 3 (External Fault (NO-Always-Coast))	
	S4	MFDI selection 4 (Fault Reset)	
	S5	MFDI selection 5 (Multi-Step Speed Reference 1)	
	S6	MFDI selection 6 (Multi-Step Speed Reference 2)	
	S7	MFDI selection 7 (Jog Reference Selection)	
	S8	MFDI selection 8 (Baseblock Command (N.O.))	
	SN	MFDI power supply 0 V	
	SC	MFDI selection common	
SP	MFDI power supply +24 VDC		
Safe Disable Input	H1	Safe Disable input 1	<p>Note: Active during Drive Mode only. Safe Disable Input Remove the jumper between terminals H1-HC and H2-HC to use the Safe Disable input.</p> <ul style="list-style-type: none"> • 24 V, 6 mA • ON: Normal operation • OFF: Coasting motor • Internal impedance 4.7 kΩ • OFF Minimum OFF time of 2 ms.
	H2	Safe Disable input 2	
	HC	Safe Disable function common	

Type	Terminal	Name (Default)	Function (Signal Level)
Analog and Pulse Train Inputs (Drive Mode only)	RP	Multi-function pulse train input (Not used)	<ul style="list-style-type: none"> Response frequency: 0 Hz to 32 Hz H level duty: 30% to 70% H level voltage: 3.5 V to 13.2 V L level voltage: 0.0 V to 0.8 V Input impedance: 3 kΩ
	+V	Power supply for frequency setting	Power Supply for Multi-Function Analog Input <ul style="list-style-type: none"> 10.5 V (allowable current 20 mA maximum)
	A1	MFAI 1 (Not used)	Voltage input or current input Select terminal A1 with Jumper switch S1 and H3-01 [Terminal A1 Signal Level Select]. <ul style="list-style-type: none"> 0 V to 10 V/100% (input impedance: 20 kΩ) 4 mA to 20 mA/100%, 0 mA to 20 mA/100% (input impedance: 250 Ω)
	A2	MFAI 2 (Not used)	Voltage input or current input Select terminal A2 with Jumper switch S1 and H3-09 [Terminal A2 Signal Level Select] <ul style="list-style-type: none"> 0 V to 10 V/100% (input impedance: 20 kΩ) 4 mA to 20 mA/100%, 0 mA to 20 mA/100% (input impedance: 250 Ω)
	A3	MFAI 3 (Auxiliary Frequency Reference 1)	Voltage input or current input Select terminal A3 with Jumper switch S1 and H3-05 [Terminal A3 Signal Level Select] <ul style="list-style-type: none"> 0 V to 10 V/100% (input impedance: 20 kΩ) 4 mA to 20 mA/100%, 0 mA to 20 mA/100% (input impedance: 250 Ω)
	AC	Analog input common	Signal Ground for Multi-Function Analog Input <ul style="list-style-type: none"> 0 V
	FE	Connecting shielded cable	Frame Earth

■ Drive Control Circuit Terminal Block Output Functions

Refer to [Table 3.19](#) and [Table 3.20](#) for a list of output terminals and functions.

Table 3.19 Drive Control Circuit Output Terminals

Type	Terminal	Name (Default)	Function (Signal Level)
Fault Relay Output	MA	N.O. output (Fault)	Note: Active during Drive Mode only. Drive Fault Signal Output <ul style="list-style-type: none"> Relay output 30 VDC, 10 mA to 2 A 250 Vac, 10 mA to 2 A Minimum load: 5 V, 10 mA (Reference value)
	MB	N.C. output (Fault)	
	MC	Digital output common	
MFDO	M1	MFDO (During Run)	Note: Active during Drive Mode only. Multi Function Digital Output <ul style="list-style-type: none"> Relay output 30 VDC, 10 mA to 2 A 250 Vac, 10 mA to 2 A Minimum load: 5 V, 10 mA (Reference value) Note: Do not set functions that frequently switch ON/OFF to MFDO (M1 to M4) because this will decrease the performance life of the relay contacts. Yaskawa estimates switching life at 200,000 times (assumes 1 A, resistive load).
	M2		
	M3	MFDO (Zero Speed)	
	M4		
	MD	N.O. output (Speed Agree 1)	
	ME	N.C. output (Speed Agree 1)	
	MF	Digital output common	

Table 3.20 Drive Control Circuit Monitor Output Terminals

Type	Terminal	Name (Default)	Function (Signal Level)
Monitor Output	FM	MFAO 1 (Output frequency)	Note: Active during Drive Mode only. Multi Function Analog Output Select voltage or current output. <ul style="list-style-type: none"> • 0 V to 10 V/0% to 100% • 4 mA to 20 mA (receiver recommended impedance: 250 Ω) Note: Select with jumper switch S5 and H4-07 [Terminal FM Signal Level Select] or H4-08 [Terminal AM Signal Level Select].
	AM	MFAO 2 (Output current)	
	AC	Monitor common	
External Power Supply Output (Not used)	+P	External power supply	Power supply for external devices. <ul style="list-style-type: none"> • 24 V (150 mA maximum)

Switches and Jumpers on the Drive Control Circuit

The terminal board has switches to adapt the drive I/Os to the external control signals as shown in [Figure 3.15](#). Set the switches to select the functions for each terminal.

Note:

Active during Drive Mode only.

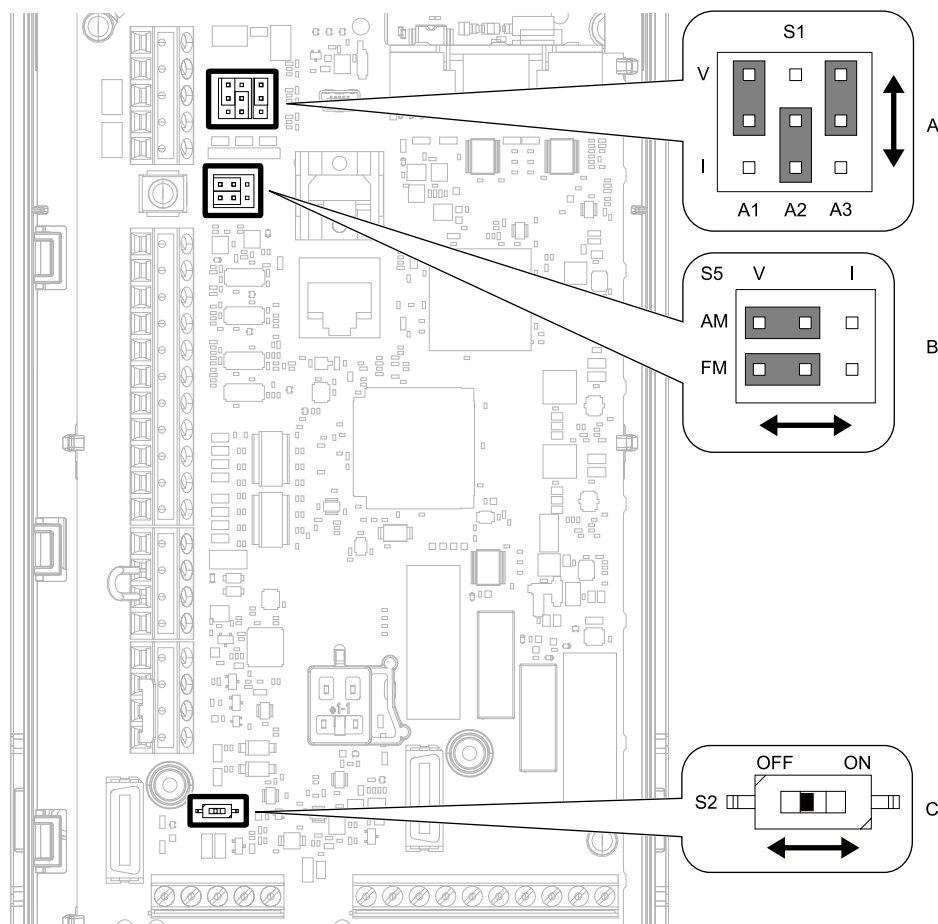

Figure 3.15 Locations of Switches

Table 3.21 I/O Terminals and Switches Functions

Position	Switch	Terminal	Function	Default Setting
A	Jumper switch S1	A1, A2, A3	Sets terminals A1 to A3 to voltage or current output.	A1: V (voltage input) A2: I (current input) A3: V (voltage input)
B	Jumper switch S5	FM, AM	Sets terminals FM and AM to voltage or current output.	FM: V (voltage output) AM: V (voltage output)
C	DIP switch S2	-	Enables and disables the termination resistor of RS-485 communications.	ON Note: This switch should always be in the ON position when the drive is part of a Bypass package.

■ Wiring the Drive Control Circuit Terminal

⚠ WARNING *Electrical Shock Hazard. Do not remove covers or touch circuit boards while the bypass is energized. If you touch the internal components of an energized bypass, it can cause serious injury or death.*

NOTICE *Do not let wire shields touch other signal lines or equipment. Insulate the wire shields with electrical tape or shrink tubing. If you do not insulate the wire shields, it can cause a short circuit and damage the drive.*

Note:

- Isolate control circuit wiring from main circuit wiring (terminals R/L1, S/L2, T/L3, U/T1, V/T2, W/T3, -, +1) and other high-power wiring. If the control circuit wires are adjacent to the main circuit wires, electrical interference can cause the drive or the devices around the drive to malfunction.
- Isolate contact output terminals MA, MB, MC and M1-M4, MD, ME, MF from other control circuit wiring. If the output terminal wires are adjacent to other control circuit wires, electrical interference can cause the drive or devices around the drive to malfunction.
- Use a UL Listed Class 2 Power Supply to connect external power to the control terminals. If the power supply for peripheral devices is incorrect, it can cause a decrease in drive performance.
- Connect the shield of shielded cable to the applicable ground terminal. If the grounding is not correct, electrical interference can cause the drive or devices around the drive to malfunction.

Correctly ground the drive terminals and complete main circuit wiring before you wire the control circuit. Remove the keypad and front cover.

1. Refer to [Figure 3.16](#) and wire the control circuit.

⚠ WARNING *Fire Hazard. Tighten all terminal screws to the correct tightening torque. Connections that are too loose or too tight can cause incorrect operation and damage to the bypass. Incorrect connections can also cause death or serious injury from fire.*

Note:

- Use shielded wires and shielded twisted-pair wires for the control circuit terminal wiring. If the grounding is not correct, electrical interference can cause the drive or devices around it to malfunction.
- Do not use control circuit wiring that is longer than 50 m (164 ft) to supply the frequency reference with an analog signal from a remote source. Wiring that is too long can cause unsatisfactory system performance.

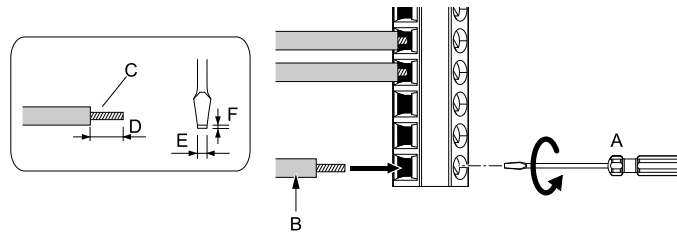

- A** - Loosen the screws and put the wire into the opening on the terminal block.
- B** - Wire with a crimp ferrule attached, or use wire that is not soldered with the core wires lightly twisted.
- C** - Pull back the shielding and lightly twist the end with your fingers to keep the ends from fraying.

- D** - If you do not use crimp ferrules, remove approximately 5.5 mm (0.21 in) of the covering at the end of the wire.
- E** - Blade width of 2.5 mm (0.1 in) or less
- F** - Blade depth of 0.4 mm (0.01 in) or less

Figure 3.16 Wiring Procedure for the Control Circuit

⚠ WARNING *Fire Hazard. Tighten all terminal screws to the correct tightening torque. Connections that are too loose or too tight can cause incorrect operation and damage to the bypass. Incorrect connections can also cause death or serious injury from fire.*

NOTICE *Do not tin stranded wire with solder. Soldered wire connections can become loose over time and cause unsatisfactory system performance.*

Note:

- Refer to [Figure 3.17](#) for information to prepare terminal ends of the shielded wire.
- Prepare the wire ends of shielded twisted-pair wires as shown in [Figure 3.17](#) to use an analog reference from an external frequency setting potentiometer to set the frequency. Connect the shield to terminal FE of the drive.

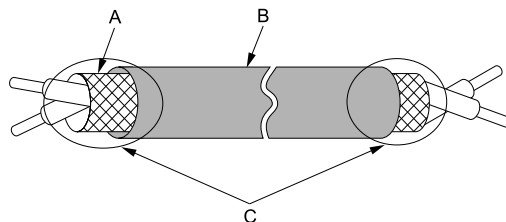

- A - Connect the shield to terminal FE of the drive.
- B - Sheath
- C - Insulate with electrical tape or shrink tubing.

Figure 3.17 Prepare the Ends of Shielded Wire

2. Install the front cover to its initial position.

◆ Control I/O Connections

This section gives information about the settings for the listed control circuit I/O signals.

- MFDI (terminals S1 to S8)
- MFDO (terminals M1 to M4 and MD to MF)
- MFAI (terminals A1 to A3)
- MFAO (terminals FM, AM)
- RS-485 communications (terminals D+, D-, AC)

■ Set Input Signals for MFAI Terminals A1 to A3

Use terminals A1 to A3 to input a voltage or a current signal. Set the signal type as shown in [Table 3.22](#).

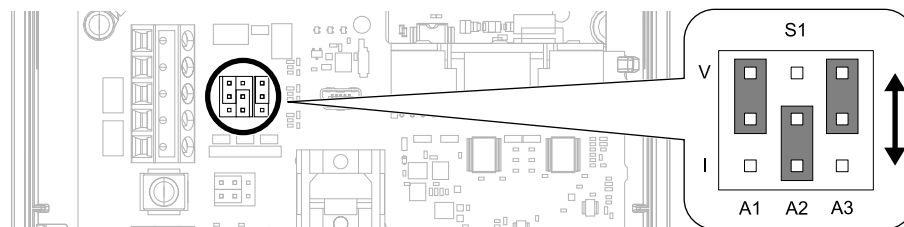

Figure 3.18 Location of Jumper Switch S1

Table 3.22 MFAI Terminals A1 to A3 Signal Settings

Terminal	Types of Input Signals	Parameter	
		No.	Signal Level
A1	Voltage input (Default)	H3-01	0: 0 V to 10 V/0% to 100% (input impedance: 20 kΩ)
	Current input		2: 4 mA to 20 mA/0% to 100% (input impedance: 250 Ω) 3: 0 mA to 20 mA/0% to 100% (input impedance: 250 Ω)
A2	Voltage input	H3-09	0: 0 V to 10 V/0% to 100% (input impedance: 20 kΩ)
	Current input (Default)		2: 4 mA to 20 mA/0% to 100% (input impedance: 250 Ω) 3: 0 mA to 20 mA/0% to 100% (input impedance: 250 Ω)

Terminal	Types of Input Signals	Parameter	
		No.	Signal Level
A3	Voltage input (Default)	H3-05	0: 0 V to 10 V/0% to 100% (input impedance: 20 kΩ)
	Current input		2: 4 mA to 20 mA/0% to 100% (input impedance: 250 Ω) 3: 0 mA to 20 mA/0% to 100% (input impedance: 250 Ω)

Note:

Set H3-02, H3-10, H3-05 = 0 [Terminal A1 Function Selection, Terminal A2 Function Selection, Terminal A3 Function Selection = Frequency Reference] to set A1 to A3 to frequency reference. The drive will add the analog input values together to make the frequency reference.

■ Set Output Signals for MFAO Terminals FM, AM

Set the signal type for terminals AM and FM to voltage or current output. Use jumper switch S5 and H4-07, H4-08 [Terminal FM Signal Level Select, Terminal AM Signal Level Select] to set the signal type.

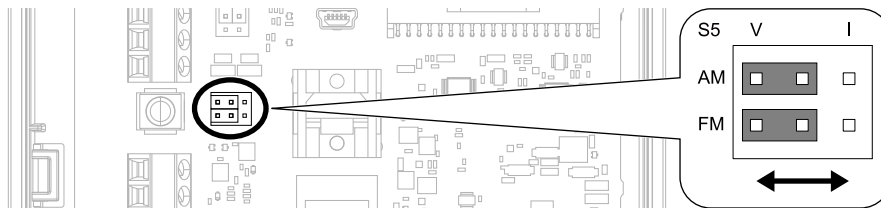

Figure 3.19 Location of Jumper Switch S5

Terminal	Types of Output Signals	Jumper Switch S5	Parameter	
			No.	Signal Level
FM	Voltage output (Default)		H4-07	0: 0 V to 10 V
	Current output			2: 4 mA to 20 mA
AM	Voltage output (Default)		H4-08	0: 0 V to 10 V
	Current output			2: 4 mA to 20 mA

◆ Connect the Bypass to a PC

The bypass control board has a mini-B type USB port.

You can use a USB cable (USB 2.0, type: A - mini-B) to connect the bypass to a type-A USB port on a PC. Open the front door of the bypass cabinet to connect the USB cable to the CN1 port on the bypass PCB. After you connect the bypass PCB to the PC, you can use Yaskawa DriveWizard Industrial software to monitor drive performance and manage parameter settings. Visit the Yaskawa website to download the DriveWizard Industrial software:

<https://www.yaskawa.com/products/drives/industrial-ac-drives/industrial-software-tools/drivewizard-industrial>

Note:

Do not connect to the USB port on the drive. Always use the CN1 port on the bypass PCB when to communicate with a bypass.

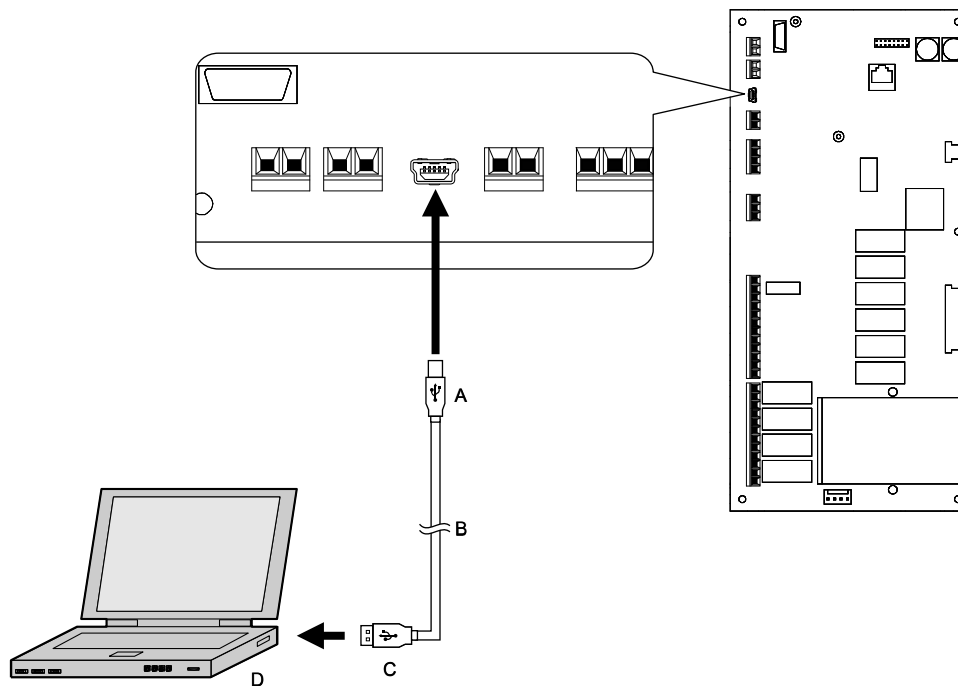

A - Mini-B type connector
B - USB 2.0, type A - mini-B cable

C - Type-A connector
D - PC

Figure 3.20 Connect to a PC (USB)

Yaskawa recommends that you use a USB cable with connectors connected with shielded wires.

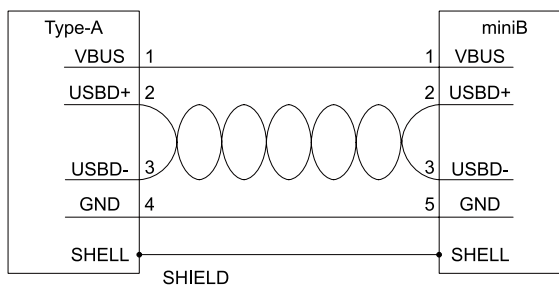

Figure 3.21 Recommended USB Cable

◆ Motor Application Precautions

■ Precautions for Existing Standard Motors

Insulation Withstand Voltage

Consider motor voltage tolerance levels and motor insulation in applications with an input voltage of over 440 V or particularly long wiring distances. Use an insulated drive motor.

NOTICE Use an inverter-duty motor with reinforced insulation and windings applicable for use with an AC drive. If the motor does not have the correct insulation, it can cause a short circuit or ground fault from insulation deterioration.

Vibration

Vibrations can occur in the these conditions:

- Resonance with the natural frequency of machinery
Use caution if you add a variable-speed drive to applications that operate the motor from line power at a constant speed. If resonance occurs, install shock-absorbing rubber around the base of the motor and enable the Jump frequency control.
- The motor is not balanced
Use caution if the motor speed is higher than the rated motor speed.

4 Startup Procedure and Test Run

- **Subsynchronous resonance**
Subsynchronous resonance can occur with long motor shafts and in applications such as turbines, blowers, and fans with high inertia loads.

Audible Noise

The audible noise of the motor changes when the carrier frequency setting changes. When you use a high carrier frequency, audible noise from the motor is equivalent to the motor noise generated when you operate from line power. If you operate at speeds that are more than the rated rotation speed, the unwanted motor noise increases.

■ **Precautions for Specialized Motors**

Pole Change Motors

The rated current of pole change motors is different than standard motors. Check the maximum current of the motor before you select a drive. Always stop the motor before you switch between the number of motor poles. If you change the number of poles while the motor is rotating, the overvoltage from regeneration or the overcurrent protection circuitry will make the motor coast to stop.

Submersible Motors

The rated current of a submersible motor is more than the rated current of a standard motor. Use a sufficiently large motor cable that will not let voltage drop decrease the maximum torque level.

Explosion-Proof Motors

You must test the motor and the drive together for explosion-proof certification. You must also test existing installations of explosion-proof motors. The drive is not designed for explosion-proof areas. Install the drive in a safe location.

The encoder used with pressure-resistant explosion-proof motors is intrinsically safe. When wiring between the drive and encoder, always connect through a specialized pulse coupler.

Geared Motors

The continuous speed range is different for different lubricating methods and manufacturers. For oil lubrication, continuous operation in the low-speed range can cause burnout. Contact the manufacturer for more information about applications where operating at more than the rated frequency is necessary.

Single-Phase Motors

Variable speed drives are not designed to operate with single-phase motors. The drive is for use with three-phase motors only. If you use capacitors to start the motor, it can cause a high frequency current to flow to the capacitors and can damage the capacitors. A split-phase start or a repulsion start can burn out the starter coils because the internal centrifugal switch is not activated.

■ **Notes on the Power Transmission Mechanism**

For power transmission machinery that uses oil to lubricate gearboxes, transmissions, or reduction gears, make sure that you use precaution if you operate the machinery continuously at low speed. Oil does not lubricate the system as well at low speeds. If you operate at frequencies higher than the rated frequency, it can cause problems with the power transmission mechanism. These problems include audible noise, decreased service life, and decreased durability.

4 Startup Procedure and Test Run

◆ **Section Safety**

⚠ DANGER *Electrical Shock Hazard. Do not examine, connect, or disconnect wiring on an energized bypass. Before servicing, disconnect all power to the equipment and wait for the time specified on the warning label at a minimum. The internal capacitor stays charged after the bypass is de-energized. The charge indicator LED extinguishes when the DC bus voltage decreases below 50 VDC. When all indicators are OFF, remove the covers before measuring for dangerous voltages to make sure that the bypass is safe. If you do work on the bypass when it is energized, it will cause serious injury or death from electrical shock.*

⚠ WARNING *Electrical Shock Hazard. Do not operate the bypass when covers are missing. Replace covers and shields before you operate the bypass. Use the bypass only as specified by the instructions. Some figures in this section include bypasses without covers or safety shields to more clearly show the inside of the bypass. If covers or safety shields are missing from the bypass, it can cause serious injury or death.*

⚠ WARNING *Electrical Shock Hazard. Do not remove covers or touch circuit boards while the bypass is energized. If you touch the internal components of an energized bypass, it can cause serious injury or death.*

NOTICE *Sudden Movement Hazard. Deactivate the Run command before you switch from Programming Mode to Drive Mode. If you switch from Programming Mode to Drive Mode and there is an active Run command, the motor will rotate and the equipment can suddenly start.*

◆ Keypad: Names and Functions

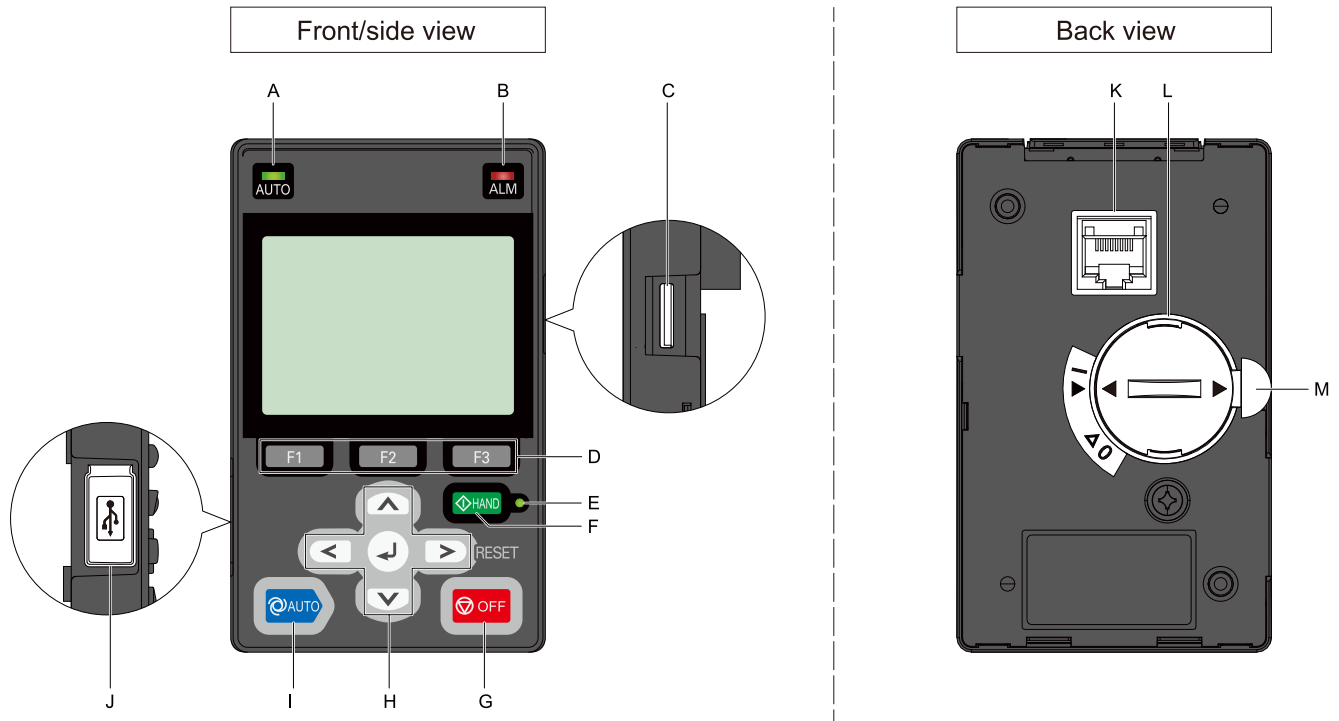











Figure 4.1 Keypad

Table 4.1 Keypad: Names and Functions

No.	Name	Function
A	AUTO LED ^{*/} 	Illuminates to show that the drive is in AUTO Mode.
B	ALM LED 	Illuminates when the drive detects a fault. Flashes when the drive detects: <ul style="list-style-type: none"> An alarm An oPE parameter setting error A fault or alarm during Auto-Tuning The LED turns off when there are no drive faults or alarms.
C	microSD Card Insertion Slot	The insertion point for a microSD card.
D	Function Keys (F1, F2, F3) 	The menu shown on the keypad sets the functions for function keys. The name of each function is in the lower half of the display window.
E	HAND LED ^{*/} 	Illuminates to show that the drive is in HAND Mode.
F	HAND Key 	Sets drive operation to HAND Mode. The drive uses the S5-01 [HAND Frequency Reference Selection] setting.

4 Startup Procedure and Test Run

No.	Name	Function
G	OFF Key 	Stops drive operation. Note: The OFF key has highest priority. Push  to stop the motor even when a Run command is active at an external Run command source. Set $o2-02 = 0$ [<i>STOP Key Function Selection = Disabled</i>] to disable  priority.
H	Left Arrow Key 	Moves the cursor to the left.
	Up Arrow Key/Down Arrow Key 	<ul style="list-style-type: none"> Scrolls up or down to display the next item or the previous item. Selects parameter numbers, and increments or decrements setting values.
	Right Arrow Key (RESET) 	<ul style="list-style-type: none"> Moves the cursor to the right. Continues to the next screen. Clears drive faults.
	ENTER Key 	<ul style="list-style-type: none"> Enters parameter values and settings. Selects menu items to move the user between keypad displays. Selects each mode, parameter, and set value.
I	AUTO Key 	Sets drive operation to AUTO Mode. The drive uses the $b1-01$ [<i>Frequency Reference Selection 1</i>] and $b1-02$ [<i>Run Command Selection 1</i>] settings. Note: Push  on the keypad to set the drive to HAND Mode before you use the keypad to operate the motor.
J	USB Terminal	Insertion point for a mini USB cable. Uses a USB cable (USB standard 2.0, type A - mini-B) to connect the keypad to a PC.
K	RJ-45 Connector	Uses an RJ-45 8-pin straight through UTP CAT5e extension cable or keypad connector to connect to the drive.
L	Clock Battery Cover	Cover for the clock battery. Note: <ul style="list-style-type: none"> The battery included with the keypad is for operation check. It may be exhausted earlier than the expected battery life described in the manual. Refer to "Maintenance & Troubleshooting Manual (TOEPYAIFP6501)" for more information about replacement procedure. To replace the battery, use a Hitachi Maxell "CR2016 Lithium Manganese Dioxide Lithium Battery" or an equivalent battery with these properties: <ul style="list-style-type: none"> Nominal voltage: 3 V Operating temperature range: -20 °C to +85 °C (-4 °F to +185 °F)
M	Insulation Sheet	An insulating sheet is attached to the keypad battery to prevent battery drain. Remove the insulation sheet before you use the keypad for the first time.

*1 Refer to [AUTO LED and HAND LED Indications on page 61](#) for more information about AUTO LED and HAND LED indications.

■ LCD Display

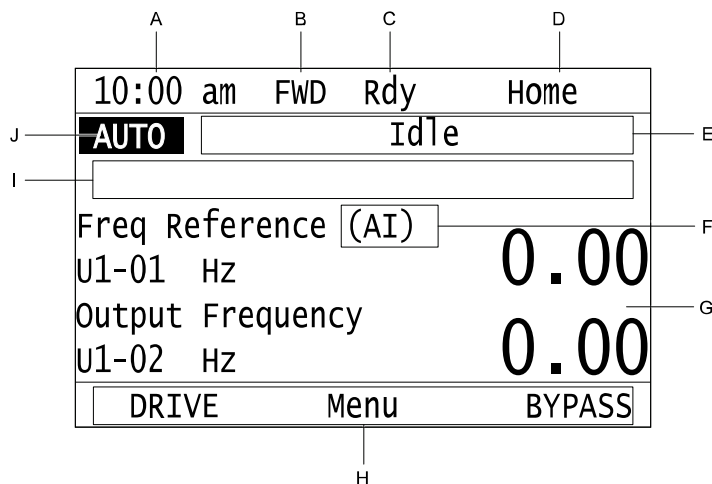





Figure 4.2 LCD Display Indications

Table 4.2 LCD Display Indications and Meanings

Symbol	Name	Description
A	Time display area	Shows the current time. Set the time on the default settings screen.
B	Forward/Reverse run indication	Shows direction of motor rotation. <ul style="list-style-type: none"> • FWD: Shown when set to Forward run. • REV: Shown when set to Reverse run.
C	Ready	The screen will show Rdy when the drive is ready for operation or when the drive is running.
D	Mode display area	Shows the name of the current mode or screen.
E	Alarm codes and status messages display area	Shows an alarm code or message about bypass status. Refer to page 114 for more information about status messages.
F	Frequency reference source indication	Shows the current frequency reference source. <ul style="list-style-type: none"> • KPD: keypad • AI: analog input terminal (Bypass PCB Terminal TB4-2) • COM: serial communications • OPT: option card
G	Data display area	Shows parameter values, monitor values, and details of the results of operations.
H	Function keys 1 to 3 (F1 to F3)	The function names shown in this area will change when the selected screen changes. Push one of the function keys  to  on the keypad to do the function.
I	Alarm and message texts display area	Shows a fault, minor fault, alarm, or error name and message text. Note: When the drive must show an alarm and a message on the keypad at the same time, the keypad will switch between the alarm code and message text in 2-second intervals.
J	HOA mode or alternative Run command source indication	<ul style="list-style-type: none"> • OFF: The bypass is operating in OFF Mode. • AUTO: The bypass is operating in AUTO Mode. • HAND: The bypass is operating in HAND Mode. • EMOV: The bypass is operating in Emergency Override Mode.

■ AUTO LED and HAND LED Indications

Table 4.3 AUTO LED and HAND LED Indications

		Status
OFF	OFF	OFF Mode
OFF	ON	HAND Mode
OFF	Long blink (50% duty)	HAND Mode <ul style="list-style-type: none"> • When the Frequency Reference is 0 or during deceleration • During PI Sleep
OFF	Double blink	HAND Mode When you clear the Run command and enter the Run command again during the time set in C1-02 [Deceleration Time 1]
ON	OFF	AUTO Mode
Long blink (50% duty)	OFF	AUTO Mode <ul style="list-style-type: none"> • When the Frequency Reference is 0 or during deceleration • During PI Sleep
Double blink	OFF	AUTO Mode When an MFDI sends a Fast Stop signal to stop the drive

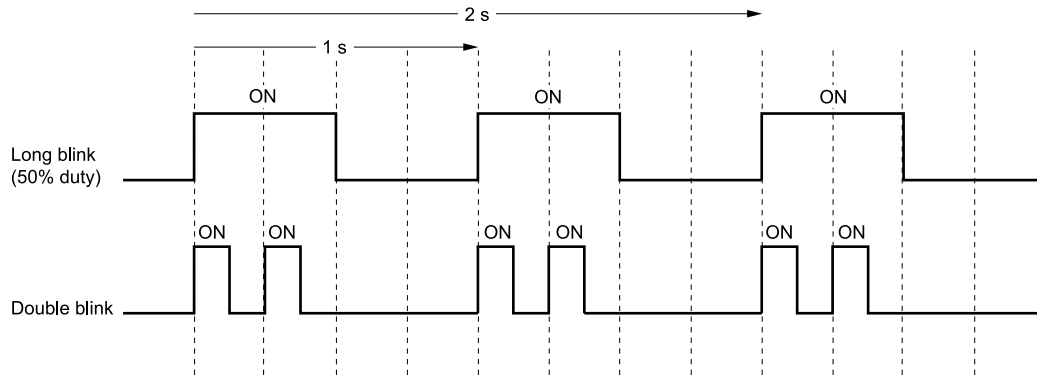

Figure 4.3 AUTO LED and HAND LED Timing Status

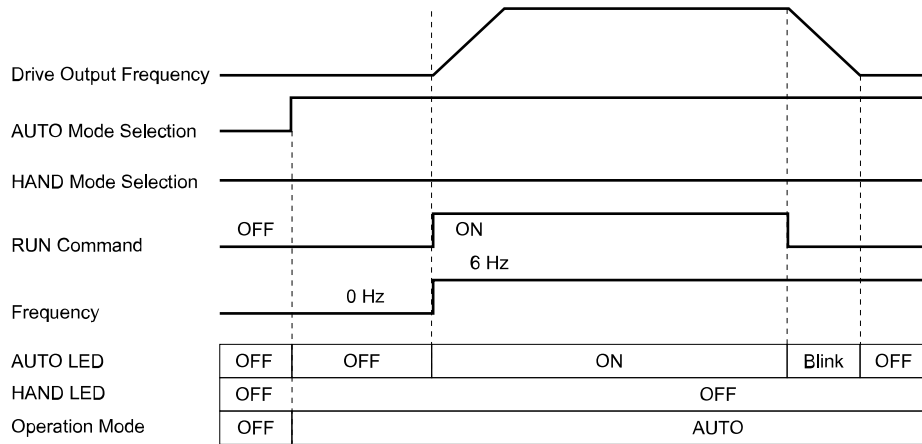

Figure 4.4 LEDs and Drive Operation in AUTO and HAND Modes

■ Keypad Mode and Menu Displays

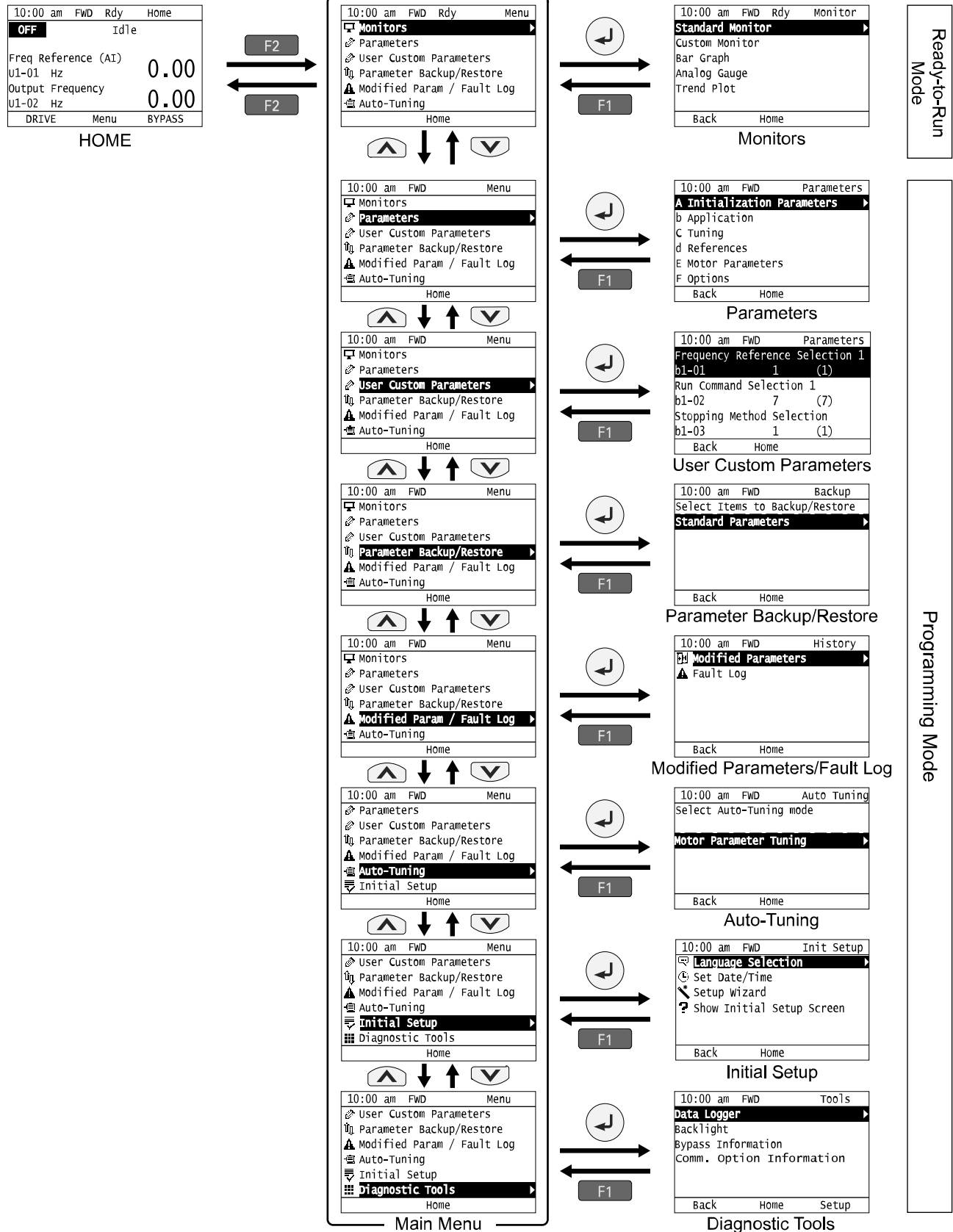

Figure 4.5 Keypad Functions and Display Levels

Note:



- Push  from the Home screen to show monitors.
- Push  to set *d1-01 [Reference 1]* when you set *b1-01 = 0 [Frequency Reference Selection 1 = Keypad]* and the Home screen shows *U1-01 [Frequency Reference]*.
- The keypad will show [Rdy] when the drive is in Ready-to-Run Mode. The drive is prepared to accept a Run command.
- The bypass will not accept a Run command in Programming Mode in the default setting. Set *b1-08 [Run Command Select in PRG Mode]* to accept or reject a Run command from an external source while in Programming Mode.
 - Set *b1-08 = 0 [Disregard RUN while Programming]* to reject the Run command from an external source while in Programming Mode (default).
 - Set *b1-08 = 1 [Accept RUN while Programming]* to accept the Run command from an external source while in Programming Mode.
 - Set *b1-08 = 2 [Allow Programming Only at Stop]* to prevent changes from Drive Mode to Programming Mode while the drive is operating.

Table 4.4 Drive Mode Screens and Functions

Mode	Keypad Screen	Function
Ready-to-Run Mode	Monitors	Sets monitor items to display.
Programming Mode	Parameters	Changes parameter settings.
	User Custom Parameters	Shows the User Parameters.
	Parameter Backup/Restore	Saves parameters to the keypad as backup.
	Modified Parameters/Fault Log	Shows modified parameters and fault history.
	Auto-Tuning	Auto-Tunes the drive.
	Initial Setup	Changes initial settings.
	Diagnostic Tools	Sets data logs and backlight. Will also show bypass and Comm. Option information (if installed).

◆ Start-up, Test Operation, and Rotation Check

This section gives the basic steps necessary to get the bypass started and make sure the motor spins in the correct direction. This section gives information about only the most basic settings.

■ Items to Check before You Energize the Bypass

1. Make sure there is no power to the bypass. Use a properly rated and functioning multimeter to make sure that it is safe and do all appropriate lockout/tagout procedures.

⚠ WARNING *Electrical Shock Hazard. Do not operate the bypass when covers are missing. Replace covers and shields before you operate the bypass. Use the bypass only as specified by the instructions. Some figures in this section include bypasses without covers or safety shields to more clearly show the inside of the bypass. If covers or safety shields are missing from the bypass, it can cause serious injury or death.*

2. Record the motor nameplate information and make sure that the input voltage aligns with the bypass rating.

Make sure that the motor rated FLA is not more than the output current rating of the bypass as shown on the bypass nameplate.

Make sure that the motor rated FLA is in range of the specifications. Refer to [Specifications on page 116](#) for information.

3. The bypass will have one of two types of main input disconnect:

A non-fusible disconnect switch

The standard bypass includes a non-fusible disconnect switch that does not provide branch circuit protection. If you will be installing the bypass according to applicable local codes and the requirements shown on the bypass nameplate, you must install appropriate branch circuit protection. Yaskawa recommends semiconductor fusing to ensure 100 kAIC SCCR panel rating. This fusing is specified on the bypass nameplate.

⚠ WARNING *Fire Hazard. You must install branch circuit protection according to applicable local codes and the requirements listed on the bypass nameplate. The bypass is suitable for use on a circuit capable of delivering not more than 100,000 RMS symmetrical amperes, 208 Vac and 480 Vac with the circuit breaker option or when protected by class J or class L fuses as specified on the bypass nameplate. Consult factory with questions. Failure to comply could result in fire and damage to the bypass unit or injury to personnel*

An input circuit breaker

Bypass Option M includes an input circuit breaker. You must use the two dials on the circuit breaker to set the adjustable trip level. The dial marked "FLA" sets the breaker to match the motor FLA. Use a small straight-edge screwdriver and adjust to the appropriate current level. The other dial sets the inrush level. Make sure this dial is set to "Auto 1" (factory setting).

4. Make sure that the available three-phase line power is the correct voltage. Connect line power to the input disconnect device.
5. Connect the bypass grounding terminal to the appropriate building ground circuit.
6. If you are using a dual voltage motor, make sure that the motor is wired for the application voltage.
7. Connect the motor to the output terminal block in the bypass or to the motor overload (if provided).
8. Connect the motor ground to the bypass drive ground terminal.
9. If you have an external motor overload, set the correct FLA from Step 2 there.
10. Use the connection diagram or the schematic packaged with the bypass to make sure that you correctly terminate wiring connections and connected to appropriate circuits at Bypass PCB A2. Please note the following with respect to the safety circuit (DI-2, terminal TB2-2) and the BAS interlock circuit (DI-3, terminal TB2-3):

Safety Interlock Circuit

DI-2 (terminal TB2-2) is provided to connect safety devices in a normally-closed series circuit, such as: freeze up thermostats, smoke/fire sensors, high pressure limits, temperature limits, or vibration detectors.

The keypad will display the status "Safety Open" if a N.C. safety circuit is not closed between DI-2 and IG24 (TB2-10) on Bypass PCB A2. An open circuit between DI-2 and IG24 will prevent drive or bypass operation.

Take ONE of these steps to ensure proper operation prior to startup:

- Install normally-closed (N.C.) safety circuit between DI-2 and IG24 on Bypass PCB A2.
- Install a jumper between DI-2 and IG24 on Bypass PCB A2.

Building Automation System Interlock Circuit (Drive and Bypass Enable Input)

The keypad will display an AL02 - Interlock Open alarm or FB-02 - Wait For Interlock Timeout fault if a N.C. safety circuit is not closed between DI-3 (TB2-3 by default setting of Z2-03) and IG24 on Bypass PCB A2 when there is an active Run command in either HAND or AUTO Mode. An open circuit between TB2-3 and IG24 (TB2-10) will prevent drive or bypass operation.

Take ONE of these steps to ensure proper operation prior to startup:

- Install a normally-closed (N.C.) BAS Interlock Circuit/Damper Interlock between DI-3 and IG24 on Bypass PCB A2.
 - Install a jumper between DI-3 and IG24 on Bypass PCB A2.
11. Record all other connections to the bypass by terminal number to determine if special programming of any of the following is required:
 - Multi-function Digital Inputs – Bypass control board TB2 (A2)
 - Multi-function Digital Outputs – Bypass control board TB1 (A2)
 - Analog Speed Reference - Bypass control board TB4 (A2)
 - Other Analog Inputs – Drive control board (A1)
 - Analog Outputs – Drive control board (A1)
 - Differential PI control – Drive control board (A1)
 - Serial Communications – Bypass control board TB3 (A2)
 12. Run all control wiring in separate conduit from motor or line power. Route digital output wiring exceeding 24 V in conduit separate from other control wiring.
 13. Make sure that the building automation system logic is ready for the start, stop, and speed command functions.

■ Bypass Start-Up Procedure

1. Replace all bypass and drive covers.
2. Before you apply power to the bypass, use a properly rated multimeter to check all three-phases of input power for proper levels and balance. Record these levels for future reference.
3. Turn the main input disconnect handle (if equipped) clockwise to energize the bypass.

4. Before you check for correct motor rotation, verify that these parameters are set correctly for your application:
 - b1-01 [Frequency Reference Selection 1]
 - b1-02 [Run Command Selection 1]
 - b3-01 [Speed Search at Start Selection]
 - b3-14 [Bi-directional Speed Search]
 - C1-01 [Acceleration Time 1]
 - C1-02 [Deceleration Time 1]
 - Z2-02 [Digital Input 2 Function (TB2-2)]
The default setting for this parameter is 22 [Run Enable - Safety (NC)]. If you do not have a safety signal, set this parameter to 0 [Not Used].
 - Z2-03 [Digital Input 3 Function (TB2-3)]
The default setting for this parameter is 23 [Run Interlock (BAS)]. If you do not have a BAS Interlock signal, set this parameter to 0 [Not Used].
 - Z2-30 [Analog Input Signal Level Select]
5. Check for correct motor rotation in Drive Mode and Bypass Mode. Refer to [Test Run and Rotation Check on page 66](#) for more information about checking and changing motor rotation.

■ Test Run and Rotation Check

Test Run (No Load)

When possible, Yaskawa recommends that you do a test run in Drive Mode and Bypass Mode to check rotation in both modes before you mechanically connect the motor to the rest of the machine. This is critically important if running the machine at full speed and/or running the machine in the wrong direction could cause damage or injury.

Rotation Check in Drive Mode and Bypass Mode

You must check the rotation in both Drive Mode and Bypass Mode. If the rotation direction is incorrect in Drive Mode, you must change the output (motor) wiring. If the rotation direction is incorrect in Bypass Mode, you must change the input power wiring.

Note:

Do the Drive Mode rotation check first. If there are any problems, make sure that you correct them before you do the Bypass Mode rotation check.

Precautions before You Do a Test Run

Before you rotate the motor, check these items:

- Check for safety issues near the bypass system, motor, and machine.
- Make sure that all safety, interlock, emergency stop circuits and safety mechanisms are operating correctly.

Test Run and Rotation Check - Drive Mode (HAND)

Note:

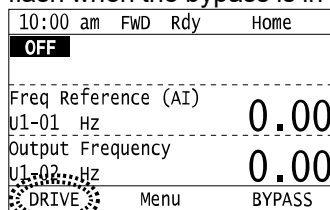

Yaskawa strongly recommends that you do the items in [Start-up, Test Operation, and Rotation Check on page 64](#) before you do this procedure.

1. Energize the bypass. If the HOME screen is not shown, push **F2**.
2. Push **OFF** to make sure that the bypass does not respond to an Auto-Run command.
3. Check the lower-left corner of the keypad screen to make sure that the bypass is in Drive Mode. "DRIVE" will flash when the bypass is in Drive Mode.





⚠ WARNING Sudden Movement Hazard. Before you do the next step, remove all personnel and objects from the area around the bypass and motor. The motor will rotate in the next step and can cause serious injury or death.

4. Push **HAND** to give the bypass a Run command from HAND Mode.

5. Push  to show S5-05 [HAND Frequency Reference], and set it to 6.00 Hz.
6. Push  to save the value and the motor will start to run.

10:00 am	FWD Rdy	Parameters
HAND Frequency Reference		
S5-05		
006.00 Hz		
Default : 0.00Hz		
Range : 0.00~400.00		
Home		Min/Max

If the system does not run, check the keypad for a “Safety Open” message or an “AL02 – Interlock Open” alarm.

- If there is a “Safety Open” message, check the safety circuit (or jumper) connected at TB2-2.
 - If there is an “AL02 – Interlock Open” alarm, check the BAS Interlock circuit (or jumper) connected at TB2-3.
7. Push  to return to the HOME screen, then push  until you can see the Output Current display on the keypad screen.

10:00 am	FWD Rdy	Monitor
Freq Reference (AI)		
U1-01 Hz		6.00
Output Frequency		
U1-02 Hz		6.00
Output Current		
U1-03 A		12.34
DRIVE	Menu	BYPASS

Output current should typically be between 20% and 100% of motor full load amps (FLA).

If the output current is **not** in this range:

- Make sure that there are no mechanical issues or binding in the machinery.
 - Make sure that the motor is correctly wired to the motor terminal block (or motor overload, if equipped).
 - Make sure that a multi-voltage motor is correctly wired in the motor junction box.
8. Look at the motor (or load) to make sure that the rotation direction is correct (Drive Mode).
If the motor direction in Drive Mode is **CORRECT**, do steps 15 to 18.
If the motor direction in Drive Mode is **INCORRECT**, do steps 9 to 14.
 9. Push  to stop the motor.
 10. De-energize the system at the power source. Observe correct lockout/tagout safety procedures and wait for the CHARGE light to completely go out on the FP605. The CHARGE light will be visible after you open the cabinet door.
 11. Open the cabinet door to access motor wiring.
 12. Switch any two phases on the **customer wiring side of the motor terminal block or motor overload**.

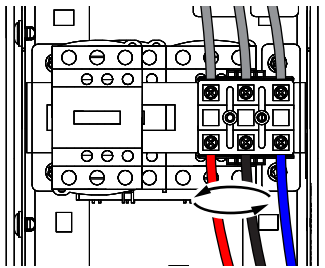



Note:

DO NOT change the wiring connected directly to the FP605 drive unit.

13. Close the cabinet door.
14. Repeat Steps 1 to 8 of this procedure to confirm correct rotation in Drive Mode.

⚠ WARNING *Sudden Movement Hazard. Before you do this step, remove all personnel and objects from the area around the bypass and motor. The motor will rotate at full speed in this step and can cause serious injury or death.*

15. Push  to give the bypass a Run command from HAND Mode.

16. Push  to show S5-05 [HAND Frequency Reference].

17. Push  to increase the frequency reference value.

Change the setting value in increments of 10 Hz if necessary and examine the response.

Each time you increase the setting value, use U1-03 [Output Current] to check the drive output current. Watch and listen for unusual conditions or noises.

When the output current of the drive is not more than the motor rated current, the status is correct.



Example: 6 Hz → 20 Hz → 30 Hz → 40 Hz → 50 Hz → 60 Hz



10:00 am	FWD	Rdy	Home
Freq Reference (AI)			
U1-01	Hz	60.00	
Output Frequency			
U1-02	Hz	60.00	
Output Current			
U1-03	A	29.48	
DRIVE	Menu	BYPASS	

18. Set the HAND frequency reference back to the desired value, then push . The Drive Mode test run and rotation check is complete.

Test Run and Rotation Check - Bypass Mode (HAND)

Before you do this procedure, Yaskawa strongly recommends that you do the items in *Start-up, Test Operation, and Rotation Check on page 64* and do the steps in *Test Run and Rotation Check - Drive Mode (HAND) on page 66*.



1. Energize the bypass. If the HOME screen is not shown, push .
2. Push  to make sure that the bypass does not respond to an Auto-Run command.
3. Check the lower-right corner of the keypad screen to make sure that the bypass is in Bypass Mode. "BYPASS" will flash when the bypass is in Bypass Mode. If it is NOT in Bypass Mode, push  to put the system into Bypass Mode

10:00 am	FWD	Rdy	Home
	Idle		
Motor Current			
Ub-01	0.00A		
DRIVE	Menu		

⚠ WARNING *Sudden Movement Hazard. Before you do the next step, remove all personnel and objects from the area around the bypass and motor. The motor will immediately rotate at full speed in the next step and can cause serious injury or death.*

4. Push  to give the bypass a Run command from HAND Mode. Make sure that Ub-01 [Motor Current] is not more than the nameplate FLA. It is normal for the current be more than full load amps temporarily at start. Watch and listen for unusual conditions or noises.

10:00 am	FWD	Rdy	Home
	Running in Bypass		
Motor Current			
Ub-01	29.48A		
DRIVE	Menu	BYPASS	

5. Look at the motor (or load) to make sure that the rotation direction is correct (Bypass Mode). If you cannot determine the rotation direction, push  and watch the motor as it coasts to stop. If the motor direction in Bypass Mode is **CORRECT**, the test is complete. If the motor direction in Bypass Mode is **INCORRECT**, do steps 6 to 11.
6. Push  to stop the motor.
7. De-energize the system at the power source. Observe correct lockout/tagout safety procedures and wait for the CHARGE light to completely go out on the FP605. The CHARGE light will be visible after you open the cabinet door.

8. Open the cabinet door to access motor wiring.
9. Switch any two phases on the **customer connection side of incoming power**.

Note:

- DO NOT change the motor (output) wiring.
- DO NOT change the wiring connected directly to the FP605 drive unit.

10. Close the cabinet door.
11. Repeat Steps 1 to 5 of this procedure to confirm correct rotation in Bypass Mode.

◆ Auto-Tuning

Auto-Tuning uses motor characteristics to automatically set parameters. Think about the type of motor and the motor installation environment and select the best Auto-Tuning method.

The keypad will show the messages with prompts to input the necessary parameter information.

■ Auto-Tuning for Induction Motors

This section gives information about Auto-Tuning for induction motors. Auto-Tuning sets motor parameters *E1-xx*, *E2-xx*.

Note:

Do Stationary Auto-Tuning if you cannot do Rotational Auto-Tuning. There can be large differences between the measured results and the motor characteristics when Auto-Tuning is complete. Examine the parameters for the measured motor characteristics after you do Stationary Auto-Tuning.

Table 4.5 Types of Auto-Tuning for Induction Motors

Mode	Application Conditions and Benefits
Rotational Auto-Tuning	<ul style="list-style-type: none"> • When you can decouple the motor and load the motor can rotate freely while Auto-Tuning. • When operating motors that have fixed output characteristics. • When it is necessary to use motors that have high-precision control. • When you cannot decouple the motor and load, but the motor load is less than 30%.
Line-to-Line Resistance	<ul style="list-style-type: none"> • After Auto-Tuning, the wiring distance between the drive and motor changed by 50 m or more. • When the wiring distance is 50 m or more in the V/f Control mode. • When the motor output and drive capacity are different.

Input Data for Induction Motor Auto-Tuning

To do Auto-Tuning, input data for the items in [Table 4.6](#) that have an "x". Before starting Auto-Tuning, prepare the motor test report or record the information on the motor nameplate as a reference.

Table 4.6 Input Data for Induction Motor Auto-Tuning

Input Data	Unit	Auto-Tuning Mode	
		Rotational Auto-Tuning	Line-to-Line Resistance
Motor Rated Power	HP	x	x
Motor Rated Voltage	V	x	-
Motor Rated Current	A	x	x
Motor Base Frequency	Hz	x	-
Number of Motor Poles	-	x	-
Motor Base Speed	RPM (min ⁻¹)	x	-
Motor Iron Loss	W	x	-

■ Precautions before Auto-Tuning

Examine the topics in this section before you start Auto-Tuning.

Prepare for Basic Auto-Tuning

- You must input data from the motor nameplate or motor test report to do Auto-Tuning. Make sure that this data is available before Auto-Tuning.
- For best performance, make sure that the input supply voltage is equal to or more than the motor rated voltage.

- Push  on the keypad to cancel Auto-Tuning.
- [Table 4.7](#) shows the status of input/output terminals during Auto-Tuning.

Table 4.7 Status of Drive Unit Input/Output Terminals during Auto-Tuning

Auto-Tuning Type	Mode		Multi-Function Inputs	Multi-Function Outputs ^{*1}
Induction Motor Auto-Tuning	Rotational	Rotational Auto-Tuning	Disabled	Functions the same as during usual operation.
	Stationary	Line-to-Line Resistance	Disabled	Keeps the status at the start of Auto-Tuning.

*1 A terminal to which $H2-xx = E$ [MFDO Function Selection = Fault] is assigned functions the same as during usual operation.

⚠ WARNING *Sudden Movement Hazard. Before you do Rotational Auto-Tuning, disconnect the load from the motor. The load can move suddenly and cause serious injury or death.*

⚠ WARNING *Injury to Personnel. Rotational Auto-Tuning rotates the motor at 50% or more of the motor rated frequency. Make sure that there are no issues related to safety in the area around the drive and motor. Increased motor frequency can cause serious injury or death.*

⚠ WARNING *Electrical Shock Hazard. During Auto-Tuning, the motor will receive high voltage when the motor is stopped. Do not touch the motor until Auto-Tuning is complete. If you touch a motor that is energized, it can cause serious injury or death.*

Precautions before Rotational Auto-Tuning

⚠ WARNING *Electrical Shock Hazard. During Auto-Tuning, the motor will receive high voltage when the motor is stopped. Do not touch the motor until Auto-Tuning is complete. If you touch a motor that is energized, it can cause serious injury or death.*

- Before you do Rotational Auto-Tuning, to prevent drive malfunction, uncouple the motor from the load. If you do Rotational Auto-Tuning with the motor connected to a load that is more than 30% of the motor duty rating, the bypass will not correctly calculate the motor parameters and the motor can operate incorrectly.
- When the load is 30% or less of the motor duty rating, you can do Auto-Tuning with the motor connected to a load.
- Make sure that external force from the machine will not cause the motor to rotate.

Precautions before Stationary Auto-Tuning

Make sure that external force from the machine will not cause the motor to rotate.

⚠ WARNING *Electrical Shock Hazard. During Auto-Tuning, the motor will receive high voltage when the motor is stopped. Do not touch the motor until Auto-Tuning is complete. If you touch a motor that is energized, it can cause serious injury or death.*

Precautions before Stationary Auto-Tuning for Line-to-Line Resistance and Stator Resistance Auto-Tuning

In V/f control, when the motor cable is 50 meters (164 feet) or longer, do Stationary Auto-Tuning for Line-to-Line Resistance.

⚠ WARNING *Electrical Shock Hazard. During Auto-Tuning, the motor will receive high voltage when the motor is stopped. Do not touch the motor until Auto-Tuning is complete. If you touch a motor that is energized, it can cause serious injury or death.*

◆ Fine Tuning during Test Runs (Adjust the Control Function)

This section gives information about the adjustment procedures to stop hunting or oscillation errors caused by control function during a test run. Adjust the applicable parameters as specified by your status.

Note:

This section only lists frequently adjusted parameters. If you must adjust parameters that have a higher degree of precision, contact Yaskawa.

■ V/f Control

Table 4.8 Parameters for Fine Tuning the Drive (V/f)

Issue	Parameter Number	Possible Solutions	Default	Recommended Setting
Hunting or oscillation at mid-range speeds (10 Hz to 40 Hz)	n1-02 [Hunting Prevention Gain Setting]	<ul style="list-style-type: none"> If torque is not sufficient with heavy loads, decrease the setting value. If hunting or oscillation occur with light loads, increase the setting value. If hunting occurs with a low-inductance motor, for example a motor with a larger frame size or a high-frequency motor, lower the setting value. 	1.00	0.10 - 2.00
<ul style="list-style-type: none"> The volume of the motor excitation sound is too high. Hunting or oscillation at low speeds (10 Hz or lower), or at mid-range speeds (10 Hz to 40 Hz) 	C6-02 [Carrier Frequency Selection]	<ul style="list-style-type: none"> If the volume of the motor excitation sound is too high, increase the carrier frequency. If hunting or oscillation occur at low or mid-range speeds, decrease the carrier frequency. 	1 (2 kHz) *1	1 to upper limit value
<ul style="list-style-type: none"> Unsatisfactory motor torque and speed response Hunting or oscillation 	C4-02 [Torque Compensation Delay Time]	<ul style="list-style-type: none"> If torque or speed response are slow, decrease the setting value. If hunting or oscillation occur, increase the setting value. 	200 ms *1	100 - 1000 ms
<ul style="list-style-type: none"> Torque at low speeds (10 Hz or lower) is not sufficient. Hunting or oscillation 	C4-01 [Torque Compensation Gain]	<ul style="list-style-type: none"> If torque at low speeds (10 Hz or lower) is not sufficient, increase the setting value. If hunting or oscillation occur with light loads, decrease the setting value. 	1.00	0.50 - 1.50
<ul style="list-style-type: none"> Torque at low speeds (10 Hz or lower) is not sufficient. Large initial vibration at start up. 	<ul style="list-style-type: none"> E1-08 [Mid Point A Voltage] E1-10 [Minimum Output Voltage] 	<ul style="list-style-type: none"> If torque at low speeds (10 Hz or lower) is not sufficient, increase the setting value. If there is large initial vibration at start up, decrease the setting value 	<ul style="list-style-type: none"> E1-08: 15.0 V *2 E1-10: 9.0 V *2 	Default setting +/- 5 V *3
Speed precision is unsatisfactory. (V/f Control)	C3-01 [Slip Compensation Gain]	Set E2-01 [Motor Rated Current], E2-02 [Motor Rated Slip], and E2-03 [Motor No-Load Current], then adjust C3-01.	0.0 (no slip compensation)	0.5 - 1.5

*1 The default setting changes when the setting for o2-04 [Drive Model (KVA) Selection] changes.

*2 The default setting changes when the setting for E1-03 [V/f Pattern Selection] changes.

*3 Recommended settings are for 208/240 V. Multiply the voltage by 2 for 480 V.

5 Troubleshooting

◆ Section Safety

⚠ DANGER *Electrical Shock Hazard. Do not examine, connect, or disconnect wiring on an energized bypass. Before servicing, disconnect all power to the equipment and wait for the time specified on the warning label at a minimum. The internal capacitor stays charged after the bypass is de-energized. The charge indicator LED extinguishes when the DC bus voltage decreases below 50 VDC. When all indicators are OFF, remove the covers before measuring for dangerous voltages to make sure that the bypass is safe. If you do work on the bypass when it is energized, it will cause serious injury or death from electrical shock.*

⚠ WARNING *Electrical Shock Hazard. Do not operate the bypass when covers are missing. Replace covers and shields before you operate the bypass. Use the bypass only as specified by the instructions. Some figures in this section include bypasses without covers or safety shields to more clearly show the inside of the bypass. If covers or safety shields are missing from the bypass, it can cause serious injury or death.*

⚠ WARNING *Electrical Shock Hazard. Always ground the motor-side grounding terminal. If you do not ground the equipment correctly, it can cause serious injury or death if you touch the motor case.*

⚠ WARNING *Electrical Shock Hazard. After the bypass blows a fuse or trips a GFCI, do not immediately energize the bypass or operate peripheral devices. Wait for the time specified on the warning label at a minimum and make sure that all indicators are OFF. Then check the wiring and peripheral device ratings to find the cause of the problem. If you do not know the cause of the problem, contact Yaskawa before you energize the bypass or peripheral devices. If you do not fix the problem before you operate the bypass or peripheral devices, it can cause serious injury or death.*

⚠ WARNING *Electrical Shock Hazard. Only let approved personnel install, wire, maintain, examine, replace parts, and repair the bypass. If personnel are not approved, it can cause serious injury or death.*

⚠ WARNING *Electrical Shock Hazard. Do not wear loose clothing or jewelry when you do work on the bypass. Tighten loose clothing and remove all metal objects, for example watches or rings. Loose clothing can catch on the bypass and jewelry can conduct electricity and cause serious injury or death.*

⚠ WARNING *Electrical Shock Hazard. Do not remove covers or touch circuit boards while the bypass is energized. If you touch the internal components of an energized bypass, it can cause serious injury or death.*

⚠ WARNING *Electrical Shock Hazard. Do not modify the bypass body, drive body, bypass circuitry, or drive circuitry. Modifications to bypass and drive body and circuitry can cause serious injury or death, will cause damage to the bypass and drive, and will void the warranty. Yaskawa is not responsible for modifications of the product made by the user.*

⚠ WARNING *Fire Hazard. Tighten all terminal screws to the correct tightening torque. Connections that are too loose or too tight can cause incorrect operation and damage to the bypass. Incorrect connections can also cause death or serious injury from fire.*

⚠ WARNING *Fire Hazard. Tighten screws at an angle in the specified range shown in this manual. If you tighten the screws at an angle not in the specified range, you can have loose connections that can cause damage to the terminal block or start a fire and cause serious injury or death.*

⚠ WARNING *Damage to Equipment. Do not apply incorrect voltage to the main circuit of the bypass. Operate the bypass in the specified range of the input voltage on the nameplate. Voltages that are higher than the permitted nameplate tolerance can cause damage to the bypass.*

⚠ WARNING *Fire Hazard. Do not put flammable or combustible materials on top of the bypass and do not install the bypass near flammable or combustible materials. Attach the bypass to metal or other noncombustible material. Flammable and combustible materials can start a fire and cause serious injury or death.*

⚠ WARNING *Crush Hazard. Wear eye protection when you do work on the bypass. If you do not use correct safety equipment, it can cause serious injury or death.*

⚠ WARNING *Crush Hazard. Use a crane or hoist to move large bypasses when necessary. If you try to move a large bypass without a crane or hoist, it can cause serious injury or death.*

NOTICE *Damage to Equipment. When you touch the bypass, drive, and circuit boards, make sure that you observe correct electrostatic discharge (ESD) procedures. If you do not follow procedures, it can cause ESD damage to the drive and bypass circuitry.*

NOTICE *Do not break the electrical connection between the bypass and the motor when the bypass is outputting voltage. Incorrect equipment sequencing can cause damage to the bypass.*

NOTICE *Make sure that all connections are correct after you install the bypass and connect peripheral devices. Incorrect connections can cause damage to the bypass.*

Note:

Do not use unshielded wire for control wiring. Use shielded, twisted-pair wires and ground the shield to the ground terminal of the bypass. Unshielded wire can cause electrical interference and unsatisfactory system performance.

◆ Types of Faults, Minor Faults, Alarms, and Errors

If the bypass or motor do not operate correctly, check the keypad for a code or message.



If problems occur that are not identified in this manual, contact the nearest Yaskawa representative with this information:

- Bypass model
- Bypass software version
- Date of purchase
- Description of the problem (such as failure conditions)

Table 5.1 contains descriptions of the different types of faults, minor faults, alarms, and errors that can occur during operation.

Contact Yaskawa if there is damage to the bypass. Contact information is on the back cover of the manual.

Table 5.1 Types of Faults, Minor Faults, Alarms, and Errors

Type	Response
Faults	<p>Drive faults thrown by the FP605 drive will stop the bypass from running the drive, but will not stop it from running in Bypass Mode.</p> <p>If $Z1-05 = 1$ [<i>Auto Transfer To Bypass = Enabled</i>], a drive fault will cause the unit to start running in Bypass Mode.</p> <p>System faults (FB0x) will stop the drive and also stop the bypass from running in Bypass Mode.</p> <p>When the bypass detects a fault, it will cause these conditions:</p> <ul style="list-style-type: none"> The keypad shows the fault code and  and ALM/ERR of the LED Status Ring illuminate continuously. The keypad shows the fault code and  and ALM/ERR on the LED Status Ring illuminate continuously when $o2-24 = 0$ or 1 [<i>LED Light Function Selection = Enable Status Ring & Keypad LED or LED Status Ring Disable</i>]. The bypass shuts off output, and the motor coasts to a stop. Some faults let the user select a motor stopping method. On the bypass control board (A2), fault output contacts TB1-11 and TB1-12 will turn ON, and TB1-10 and TB1-11 will turn OFF. This requires that $Z2-26 = 15$ [<i>Digital Output 10 (TB110-12) = Fault Active</i>], which is the default setting. <p>The bypass will not operate until you clear the fault with a Fault Reset and the bypass goes back to usual status.</p>
Minor Faults/Alarms	<p>When the bypass detects a minor fault or an alarm, it will cause these conditions:</p> <ul style="list-style-type: none"> The keypad shows the alarm code and  and ALM/ERR on the LED Status Ring flash when $o2-24 = 0$ or 1. The bypass will continue to operate the motor. Some alarms let the user select a motor stopping method. If the bypass detects a minor fault, the terminal set to $H2-01$ to $H2-03 = 10$ [<i>MFDO Function Select = Alarm</i>] will switch ON. If you do not set parameters $H2-01$ to $H2-03$, the bypass will not trigger MFDO terminals when it detects a minor fault. The bypass will not output a minor fault signal when it detects an alarm. <p>It is not necessary to do Fault Reset.</p>
Operation Errors	<p>An error occurs when parameter settings do not agree or a parameter combination is incorrect. The bypass will not operate until you set the parameters correctly.</p> <p>When the bypass detects an operation error, these conditions will result:</p> <ul style="list-style-type: none"> The keypad shows the error code. Multi-function outputs do not output an alarm signal. <p>Find the parameters that caused the error and correct the settings.</p>
Auto-Tuning Errors	<p>An error occurs during Auto-Tuning.</p> <p>When the bypass detects a tuning error, it will cause these conditions:</p> <ul style="list-style-type: none"> The keypad shows the error code. Multi-function outputs do not output an alarm signal. The motor coasts to stop. <p>Remove the cause of the error and do Auto-Tuning again.</p>
Copy Function Errors	<p>An error occurs when you use the keypad for a backup, restore, or verify operation.</p> <p>When the bypass detects a copy function error, it will cause these conditions:</p> <ul style="list-style-type: none"> The keypad shows the error code. Multi-function outputs do not output an alarm signal. <p>Push a key on the keypad to clear the error. Remove the cause of the error and try the backup, restore, or verify operation again.</p>

◆ Faults, Minor Faults, Alarms, and Error Codes Listed Alphabetically

Table 5.2 shows the possible fault, minor fault, alarm, and error codes.

The display codes are in alphabetical order. Search the table for the code shown on the keypad, and identify its causes and possible solutions.

Drive Faults thrown by the FP605 drive will stop the bypass from running the drive but will not stop it from running in Bypass Mode.

System Faults will stop the drive and also keep it from running in Bypass Mode.

Note:

The number in parentheses adjacent to the code in the table identifies the fault code or minor fault code (hex. number) that was read during serial communications.

Example: AFBL (00A2)

Table 5.2 List of Fault, Minor Fault, Alarm, and Error Codes

Display (Hex.)	Name	ALM LED	Type	Ref.
AFBL (00A2)	Analog Fbk Lost, Switched to Net	Flashing	Alarm	100
AL02 (00B2)	Interlock Open	Flashing	Alarm	100

5 Troubleshooting

Display (Hex.)	Name	ALM LED	Type	Ref.
AL03 (00B3)	Emergency Override Bypass	Flashing	Alarm	100
AL09 (00B9)	Restart Delay Active	Flashing	Alarm	100
AL13 (00BD)	Loss of Load Detected	Flashing	Alarm	100
AL16 (00C0)	Input Phase Rotation	Flashing	Alarm	100
AL17 (00C1)	Remote Xfer disabled in Reverse	Flashing	Alarm	100
AL18 (00C2)	Auto Xfer disabled in Reverse	Flashing	Alarm	100
AuDis (00A3)	Low PI Aux Fdbk Drive Disabled	Flashing	Alarm	100
AuFbl (00A5)	PI Aux Fdbk Lost Switched to Net	Flashing	Alarm	100
AUXFB (00A4)	PI Aux Feedback Level Loss	Flashing	Alarm	100
AUXFB (0420)	PI Aux Feedback Level Loss	Illuminated	Drive Fault	85
bAT (0085)	Keypad Battery Low Voltage	Flashing	Alarm	100
bAT (0402)	Keypad Battery Low Voltage	Illuminated	Drive Fault	85
bb (0008)	Baseblock	Flashing	Alarm	100
bCE (0416)	Bluetooth Communication Fault	Illuminated	Drive Fault	85
bCE (008A)	Bluetooth Communication Error	Flashing	Alarm	100
BuDif (00A6)	Main Fdbk Lost, Using Diff Fdbk	Flashing	Alarm	100
Bu-Fb (0090)	Main Fdbk Lost Using Backup Fdbk	Flashing	Alarm	100
BuFbl (0091)	Backup Fdbk Lost Chk/Repl Xducer	Flashing	Alarm	100
bUS (0015)	Option Communication Error	Flashing	Alarm	100
bUS (0022)	Option Communication Error	Illuminated	Drive Fault	85
bUSy	Busy	-	Not an alarm.	101
CALL (001D)	Serial Comm Transmission Error	Flashing	Alarm	101
CE (0092)	Run at H5-34 (CE Go-To-Freq)	Flashing	Alarm	101
CE (0014)	Serial Communication Error	Flashing	Alarm	101
CE (0021)	Serial Communication Error	Illuminated	Drive Fault	86
CoF (0046)	Current Offset Fault	Illuminated	Drive Fault	86
CPF00 (0081)	Control Circuit Error	Illuminated	Drive Fault	86
CPF01 (0082)	Control Circuit Error	Illuminated	Drive Fault	86
CPF02 (0083)	A/D Conversion Error	Illuminated	Drive Fault	86
CPF03 (0084)	Control Board Connection Error	Illuminated	Drive Fault	86
CPF06 (0087)	EEPROM Memory Data Error	Illuminated	Drive Fault	86
CPF07 (0088)	Terminal Board Connection Error	Illuminated	Drive Fault	86
CPF08 (0089)	Terminal Board Connection Error	Illuminated	Drive Fault	86
CPF11 (008C)	RAM Fault	Illuminated	Drive Fault	86
CPF12 (008D)	FLASH Memory Fault	Illuminated	Drive Fault	87
CPF13 (008E)	Watchdog Circuit Exception	Illuminated	Drive Fault	87
CPF14 (008F)	Control Circuit Fault	Illuminated	Drive Fault	87
CPF16 (0091)	Clock Fault	Illuminated	Drive Fault	87
CPF17 (0092)	Timing Fault	Illuminated	Drive Fault	87
CPF18 (0093)	Control Circuit Fault	Illuminated	Drive Fault	87
CPF19 (0094)	Control Circuit Fault	Illuminated	Drive Fault	87
CPF20 (0095)	Control Circuit Error	Illuminated	Drive Fault	87
CPF21 (0096)	Control Circuit Error	Illuminated	Drive Fault	87

Display (Hex.)	Name	ALM LED	Type	Ref.
CPF22 (0097)	Hybrid IC Error	Illuminated	Drive Fault	87
CPF23 (0098)	Control Board Connection Error	Illuminated	Drive Fault	87
CPF24 (0099)	Drive Unit Signal Fault	Illuminated	Drive Fault	87
CPF26 (009B)	BB Circuit Error	Illuminated	Drive Fault	87
CPF27 (009C)	PWM Set Reg Error	Illuminated	Drive Fault	87
CPF28 (009D)	PWM Pattern Error	Illuminated	Drive Fault	87
CPF29 (009E)	On-Delay Error	Illuminated	Drive Fault	87
CPF30 (009F)	BB On Error	Illuminated	Drive Fault	87
CPF31 (00A0)	ASIC Code Error	Illuminated	Drive Fault	88
CPF32 (00A1)	ASIC Startup Error	Illuminated	Drive Fault	88
CPF33 (00A2)	Watch-dog Error	Illuminated	Drive Fault	88
CPF34 (00A3)	Power/Clock Error	Illuminated	Drive Fault	88
CPF35 (00A4)	Ext A/D Conv Error	Illuminated	Drive Fault	88
CPF36 (00A5)	ASIC COM Error	Illuminated	Drive Fault	88
CPF37 (00A6)	ASIC COM Error	Illuminated	Drive Fault	88
CPF38 (00A7)	EEPROM Data Error	Illuminated	Drive Fault	88
CPF39 (00A8)	CPU-ASIC Communication Error	Illuminated	Drive Fault	88
CPyE	Error Writing Data	-	Backup Function Runtime Error	113
CrST	Cannot Reset	Flashing	Not an alarm.	102
CSEr	Control Mode Mismatch	-	Backup Function Runtime Error	113
CyPo (0029)	Cycle Power to Accept Changes	Flashing	Alarm	102
dFPS	Drive Model Mismatch	-	Backup Function Runtime Error	113
DIFF (0093)	Differential Feedback Exceeded	Flashing	Alarm	102
DIFF (0421)	Differential Feedback Exceeded	Illuminated	Drive Fault	88
dnE (002A)	Drive Disabled	Flashing	Alarm	102
dv7 (005B)	Polarity Judge Timeout	Illuminated	Drive Fault	88
EF (0007)	FWD/REV Run Command Input Error	Flashing	Alarm	102
EF0 (001A)	Option Card External Fault	Flashing	Alarm	102
EF0 (0027)	Option Card External Fault	Illuminated	Drive Fault	88
EF1 (0039)	External Fault (Terminal S1)	Flashing	Alarm	102
EF1 (0042)	External Fault (Terminal S1)	Illuminated	Drive Fault	88
EF2 (003A)	External Fault (Terminal S2)	Flashing	Alarm	102
EF2 (0043)	External Fault (Terminal S2)	Illuminated	Drive Fault	88
EF3 (0009)	External Fault (Terminal S3)	Flashing	Alarm	102
EF3 (0011)	External Fault (Terminal S3)	Illuminated	Drive Fault	89
EF4 (000A)	External Fault (Terminal S4)	Flashing	Alarm	102
EF4 (0012)	External Fault (Terminal S4)	Illuminated	Drive Fault	89
EF5 (000B)	External Fault (Terminal S5)	Flashing	Alarm	102
EF5 (0013)	External Fault (Terminal S5)	Illuminated	Drive Fault	89
EF6 (000C)	External Fault (Terminal S6)	Flashing	Alarm	103
EF6 (0014)	External Fault (Terminal S6)	Illuminated	Drive Fault	89
EF7 (000D)	External Fault (Terminal S7)	Flashing	Alarm	103
EF7 (0015)	External Fault (Terminal S7)	Illuminated	Drive Fault	89

5 Troubleshooting

Display (Hex.)	Name	ALM LED	Type	Ref.
EF8 (000E)	External Fault (Terminal S8)	Flashing	Alarm	103
EF8 (0016)	External Fault (Terminal S8)	Illuminated	Drive Fault	89
End1	Excessive Rated Voltage Setting	Flashing	An Auto-Tuning Error	111
End2	Iron Core Saturation Coefficient	Flashing	An Auto-Tuning Error	111
End3	Rated Current Setting Alarm	Flashing	An Auto-Tuning Error	111
End4	Adjusted Slip Calculation Error	Flashing	An Auto-Tuning Error	111
End5	Resistance Tuning Error	Flashing	An Auto-Tuning Error	111
End6	Leakage Inductance Alarm	Flashing	An Auto-Tuning Error	111
End7	No-Load Current Alarm	Flashing	An Auto-Tuning Error	111
EOF (0067)	Emergency Override FWD	Flashing	Alarm	103
EOR (0068)	Emergency Override REV	Flashing	Alarm	103
EP24v (0081)	External Power 24V Supply	Flashing	Alarm	103
Er-01	Motor Data Error	Flashing	An Auto-Tuning Error	111
Er-02	Drive in an Alarm State	Flashing	An Auto-Tuning Error	111
Er-03	STOP Button was Pressed	Flashing	An Auto-Tuning Error	112
Er-04	Line-to-Line Resistance Error	Flashing	An Auto-Tuning Error	112
Er-05	No-Load Current Error	Flashing	An Auto-Tuning Error	112
Er-08	Rated Slip Error	Flashing	An Auto-Tuning Error	112
Er-09	Acceleration Error	Flashing	An Auto-Tuning Error	112
Er-12	Current Detection Error	Flashing	An Auto-Tuning Error	112
Er-13	Leakage Inductance Error	Flashing	An Auto-Tuning Error	112
Er-18	Back EMF Error	Flashing	An Auto-Tuning Error	113
Er-25	HighFreq Inject Param Tuning Err	Flashing	An Auto-Tuning Error	113
Err (001F)	EEPROM Write Error	Illuminated	Drive Fault	89
FAn1 (0413)	Drive Cooling Fan Fault	Illuminated	Drive Fault	89
FB02 (043A)	Wait For Interlock Timeout	Illuminated	System Fault	89
FB03 (043B)	External Fault Bypass (EFB)	Illuminated	System Fault	90
FB05 (043D)	Motor Overload	Illuminated	System Fault	90
FB06 (043E)	External Overload 1	Illuminated	System Fault	90
FB07 (043F)	External Overload 2	Illuminated	System Fault	90
FB08 (0440)	Brownout Detected	Illuminated	System Fault	91
FB09 (0441)	Blackout Detected	Illuminated	System Fault	91
FB10 (0442)	Loss of Drive Communications	Illuminated	Drive Fault	91
FB13 (0445)	Loss of Load	Illuminated	System Fault	91
FB15 (0447)	Input Phase Loss	Illuminated	System Fault	91
FB16 (0448)	Input Phase Rotation	Illuminated	System Fault	91
FB17 (0449)	Load Verify Fault	Illuminated	System Fault	91
FB18 (044A)	Welded Bypass Contactor Detected	Illuminated	System Fault	91
FB26 (0452)	Option on Drive Detected	Illuminated	Drive Fault	91
FB27 (0453)	Drive Hardware Fault (CPFx oFx)	Illuminated	Drive Fault	91
FB28 (0454)	Drive Faulted	Illuminated	System Fault	91
FB30 (0456)	Conflicting SW Check UB-99	Illuminated	Drive Fault	91
FDBKL (0094)	Feedback Loss Wire Break	Flashing	Alarm	103

Display (Hex.)	Name	ALM LED	Type	Ref.
FDBKL (0422)	WIRE Break	Illuminated	Drive Fault	92
FIRE_ST (00CA)	Fire Stat Open	Flashing	Alarm	103
FREEZ_ST (00CB)	Freeze Stat Open	Flashing	Alarm	103
FLGT (0095)	Feedback Loss, Go To Freq b5-83	Flashing	Alarm	103
FR<MS (009E)	Freq Ref < Minimum Speed (Y1-06)	Flashing	Alarm	103
FR<TH (009F)	Freq. Reference < Thrust (Y4-12)	Flashing	Alarm	104
GF (0006)	Ground Fault	Illuminated	Drive Fault	92
HCA (0034)	High Current Alarm	Flashing	Alarm	104
HFB (0423)	High Feedback Sensed	Illuminated	Drive Fault	92
HIAUX (0096)	High PI Aux Feedback Level	Flashing	Alarm	104
HIAUX (0424)	High PI Aux Feedback Level	Illuminated	Drive Fault	92
HIFB (0097)	High Feedback Sensed	Flashing	Alarm	104
HWL (00C6)	High Water Level	Flashing	Alarm	104
iFEr	Communication Err	-	Backup Function Runtime Error	113
INTLK (0069)	BAS Interlock	Flashing	Alarm	104
LCP (00A7)	Low City Pressure	Flashing	Alarm	104
LF (001C)	Output Phase Loss	Illuminated	Drive Fault	92
LF2 (0036)	Output Current Imbalance	Illuminated	Drive Fault	92
LFB (0425)	Low Feedback Sensed	Illuminated	Drive Fault	92
LOAUX (0099)	Low PI Aux Feedback Level	Flashing	Alarm	104
LOAUX (0426)	Low PI Aux Feedback Level	Illuminated	Drive Fault	92
LoG	Com Error / Abnormal SD Card	Flashing	Alarm	104
LOFB (009A)	Low Feedback Sensed	Flashing	Alarm	104
LOP (009B)	Loss of Prime	Flashing	Alarm	105
LOP (0427)	Loss of Prime	Illuminated	Drive Fault	92
LOW_SUCT (00CE)	Low Suction Detected	Flashing	Alarm	105
LSP (00A8)	Low Suction Pressure	Flashing	Alarm	105
LT-1 (0035)	Cooling Fan Maintenance Time	Flashing	Alarm	105
LT-2 (0036)	Capacitor Maintenance Time	Flashing	Alarm	105
LT-3 (0043)	SoftChargeBypassRelay MainteTime	Flashing	Alarm	105
LT-4 (0044)	IGBT Maintenance Time (50%)	Flashing	Alarm	105
LWL (00D0)	Low Water Level	Flashing	Alarm	105
LWT (00A9)	Low Water In Tank	Flashing	Alarm	105
ndAT	Model,VolClass,Capacity Mismatch	-	Backup Function Runtime Error	113
NMS (009C)	Setpoint Not Met	Flashing	Alarm	105
NMS (0429)	Setpoint Not Met	Illuminated	Drive Fault	93
oC (0007)	Overcurrent	Illuminated	Drive Fault	93
OD (009D)	Output Disconnect	Flashing	Alarm	105
OD (042A)	Output Disconnect	Illuminated	Drive Fault	93
oFA00 (0101)	Option Not Compatible with Port	Illuminated	Drive Fault	93
oFA01 (0102)	Option Fault/Connection Error	Illuminated	Drive Fault	94
oFA05 (0106)	Option A/D Error	Illuminated	Drive Fault	94
oFA06 (0107)	Option Communication Error	Illuminated	Drive Fault	94

5 Troubleshooting

Display (Hex.)	Name	ALM LED	Type	Ref.
oFA10 (0111)	Option RAM Error	Illuminated	Drive Fault	94
oFA11 (0112)	Option Ope Mode Error	Illuminated	Drive Fault	94
oFA12 (0113)	Drive Receive CRC Error	Illuminated	Drive Fault	94
oFA13 (0114)	Drive Receive Frame Error	Illuminated	Drive Fault	94
oFA14 (0115)	Drive Receive Abort Error	Illuminated	Drive Fault	94
oFA15 (0116)	Option Receive CRC Error	Illuminated	Drive Fault	94
oFA16 (0117)	Option Receive Frame Error	Illuminated	Drive Fault	94
oFA17 (0118)	Option Receive Abort Error	Illuminated	Drive Fault	94
oFA30 (0131)	COM ID Error	Illuminated	Drive Fault	94
oFA31 (0132)	Type Code Error	Illuminated	Drive Fault	94
oFA32 (0133)	SUM Check Error	Illuminated	Drive Fault	94
oFA33 (0134)	Option Receive Time Over	Illuminated	Drive Fault	94
oFA34 (0135)	Memobus Time Over	Illuminated	Drive Fault	94
oFA35 (0136)	Drive Receive Time Over 1	Illuminated	Drive Fault	95
oFA36 (0137)	CI Check Error	Illuminated	Drive Fault	95
oFA37 (0138)	Drive Receive Time Over 2	Illuminated	Drive Fault	95
oFA38 (0139)	Control Reference Error	Illuminated	Drive Fault	95
oFA39 (013A)	Drive Receive Time Over 3	Illuminated	Drive Fault	95
oFA40 (013B)	CtrlResSel 1Err	Illuminated	Drive Fault	95
oFA41 (013C)	Drive Receive Time Over 4	Illuminated	Drive Fault	95
oFA42 (013D)	CtrlResSel 2Err	Illuminated	Drive Fault	95
oFA43 (013E)	Drive Receive Time Over 5	Illuminated	Drive Fault	95
oH (0003)	Heatsink Overheat	Flashing	Alarm	105
oH (0009)	Heatsink Overheat	Illuminated	Drive Fault	95
oH1 (000A)	Heatsink Overheat	Illuminated	Drive Fault	95
oH2 (0004)	External Overheat (H1-XX=B)	Flashing	Alarm	105
oH3 (001D)	Motor Overheat (PTC Input)	Illuminated	Drive Fault	95
oH3 (0022)	Motor Overheat (PTC Input)	Flashing	Alarm	106
oH4 (0020)	Motor Overheat Fault (PTC Input)	Illuminated	Drive Fault	96
oL1 (000B)	Motor Overload	Illuminated	Drive Fault	96
oL2 (000C)	Drive Overload	Illuminated	Drive Fault	97
oL3 (0005)	Overtorque 1	Flashing	Alarm	106
oL3 (000D)	Overtorque Detection 1	Illuminated	Drive Fault	97
oL4 (0006)	Overtorque 2	Flashing	Alarm	106
oL4 (000E)	Overtorque Detection 2	Illuminated	Drive Fault	97
oL7 (002B)	High Slip Braking Overload	Illuminated	Drive Fault	97
oPE01	Drive Capacity Setting Fault	Flashing	Parameter Setting Error	108
oPE02	Parameter Range Setting Error	Flashing	Parameter Setting Error	108
oPE03	Multi-Function Input Setting Err	Flashing	Parameter Setting Error	108
oPE05	Run Cmd/Freq Ref Source Sel Err	Flashing	Parameter Setting Error	109
oPE07	Analog Input Selection Error	Flashing	Parameter Setting Error	109
oPE08	Parameter Selection Error	Flashing	Parameter Setting Error	110
oPE09	PID Control Selection Fault	Flashing	Parameter Setting Error	110

Display (Hex.)	Name	ALM LED	Type	Ref.
oPE10	V/f Data Setting Error	Flashing	Parameter Setting Error	110
oPE11	Carrier Frequency Setting Error	Flashing	Parameter Setting Error	110
oPE16	Energy Saving Constants Error	Flashing	Parameter Setting Error	110
oPE29	Baud Rate Setting Error	Flashing	Parameter Setting Error	110
oPE34	HAND/OFF/AUTO Input Setting	Flashing	Parameter Setting Error	110
oPE36	Bypass Energy Savings Setting Err	Flashing	Parameter Setting Error	110
oPr (001E)	Keypad Connection Fault	Illuminated	Drive Fault	97
ov (0002)	DC Bus Overvoltage	Flashing	Alarm	106
ov (0008)	Overvoltage	Illuminated	Drive Fault	97
ov2 (0405)	DC Bus Overvoltage 2	Illuminated	Drive Fault	98
ovEr	Too Many Parameters Changed	-	Not an alarm.	106
OV_PRESS (00CD)	Over Pressure Detected	Flashing	Alarm	106
PA1 (003F)	PLC Error 1	Flashing	Alarm	106
PASS	Serial Communication Test	Flashing	Not an alarm.	106
PE1 (0047) PE2 (0048)	PLC Faults	Illuminated	Drive Fault	98
PF (0047)	Input Phase Loss	Flashing	Alarm	106
PF (001B)	Input Phase Loss	Illuminated	Drive Fault	98
PSE (0437)	JOHB-SMP3 Protocol set Error	Illuminated	Drive Fault	98
rdEr	Error Reading Data	-	Backup Function Runtime Error	113
SAFE (00C9)	Safety Open	Flashing	Alarm	107
SC (0005)	Short Circuit/IGBT Failure	Illuminated	Drive Fault	98
SCF (040F)	Safety Circuit Fault	Illuminated	Drive Fault	99
SE (0020)	Modbus Test Mode Error	Flashing	Alarm	107
SEr (003B)	Speed Search Retries Exceeded	Illuminated	Drive Fault	99
SMK_ALRM (00CC)	Smoke Alarm Active	Flashing	Alarm	107
STo (003C)	Safe Torque OFF	-	Alarm	107
SToF (003B)	Safe Torque OFF	Flashing	Alarm	107
TiM (0089)	Keypad Time Not Set	Flashing	Alarm	107
TiM (0401)	Keypad Time Not Set	Illuminated	Drive Fault	99
TrPC (0042)	IGBT Maintenance Time (90%)	Flashing	Alarm	107
UL3 (001E)	Undertorque Detection 1	Flashing	Alarm	107
UL3 (0029)	Undertorque Detection 1	Illuminated	Drive Fault	99
UL4 (001F)	Undertorque Detection 2	Flashing	Alarm	107
UL4 (002A)	Undertorque Detection 2	Illuminated	Drive Fault	99
UL6 (004E)	Underload or Belt Break Detected	Flashing	Alarm	107
UL6 (005A)	Underload or Belt Break Detected	Illuminated	Drive Fault	99
Uv (0001)	DC Bus Undervoltage	Flashing	Alarm	107
Uv1 (0002)	DC Bus Undervoltage	Illuminated	Drive Fault	99
Uv2 (0003)	Control Power Undervoltage	Illuminated	Drive Fault	99
Uv3 (0004)	Soft Charge Answerback Fault	Illuminated	Drive Fault	99
vAEr	Voltage Class, Capacity Mismatch	-	Backup Function Runtime Error	113
VBRATION (00CF)	Vibration Detected	Flashing	Alarm	108

Display (Hex.)	Name	ALM LED	Type	Ref.
vFyE	Parameters do not Match	-	Backup Function Runtime Error	113
VLTS (042B)	Thermostat Fault	Illuminated	Drive Fault	99

◆ Faults, Minor Faults, Alarms, and Error Codes Listed by Decimal Value for Use with BACnet/Modbus

Table 5.3 shows the list of faults by decimal number. Faults are read in Modbus register 0080 or BACnet AV42.

Table 5.4 shows the list of minor faults and alarms by decimal number. Minor fault and alarm decimal numbers are read in Modbus register 007F.

The display codes are in decimal order. Search the tables for the decimal code, and identify its causes and possible solutions.

Drive Faults thrown by the FP605 drive will stop the bypass from running the drive but will not stop it from running in Bypass Mode.

System Faults will stop the drive and also stop it from running in Bypass Mode.

Note:

The number in parentheses adjacent to the code in the table identifies the fault code or minor fault code (hex. number) that was read during serial communications.

Example: AFBL (00A2)

Table 5.3 List of Faults by Decimal

Decimal Value	Display (Hex.)	Name	ALM LED	Type	Ref.
2	Uv1 (0002)	DC Bus Undervoltage	Illuminated	Drive Fault	99
3	Uv2 (0003)	Control Power Undervoltage	Illuminated	Drive Fault	99
4	Uv3 (0004)	Soft Charge Answerback Fault	Illuminated	Drive Fault	99
5	SC (0005)	Short Circuit/IGBT Failure	Illuminated	Drive Fault	98
6	GF (0006)	Ground Fault	Illuminated	Drive Fault	92
7	oC (0007)	Overcurrent	Illuminated	Drive Fault	93
8	ov (0008)	Overvoltage	Illuminated	Drive Fault	97
9	oH (0009)	Heatsink Overheat	Illuminated	Drive Fault	95
10	oH1 (000A)	Heatsink Overheat	Illuminated	Drive Fault	95
11	oL1 (000B)	Motor Overload	Illuminated	Drive Fault	96
12	oL2 (000C)	Drive Overload	Illuminated	Drive Fault	97
13	oL3 (000D)	Overtorque Detection 1	Illuminated	Drive Fault	97
14	oL4 (000E)	Overtorque Detection 2	Illuminated	Drive Fault	97
17	EF3 (0011)	External Fault (Terminal S3)	Illuminated	Drive Fault	89
18	EF4 (0012)	External Fault (Terminal S4)	Illuminated	Drive Fault	89
19	EF5 (0013)	External Fault (Terminal S5)	Illuminated	Drive Fault	89
20	EF6 (0014)	External Fault (Terminal S6)	Illuminated	Drive Fault	89
21	EF7 (0015)	External Fault (Terminal S7)	Illuminated	Drive Fault	89
22	EF8 (0016)	External Fault (Terminal S8)	Illuminated	Drive Fault	89
25	dEv (0019)	Speed Deviation	Illuminated	Drive Fault	88
27	PF (001B)	Input Phase Loss	Illuminated	Drive Fault	98
28	LF (001C)	Output Phase Loss	Illuminated	Drive Fault	92
29	oH3 (001D)	Motor Overheat (PTC Input)	Illuminated	Drive Fault	95
30	oPr (001E)	Keypad Connection Fault	Illuminated	Drive Fault	97
31	Err (001F)	EEPROM Write Error	Illuminated	Drive Fault	89

Decimal Value	Display (Hex.)	Name	ALM LED	Type	Ref.
32	oH4 (0020)	Motor Overheat Fault (PTC Input)	Illuminated	Drive Fault	96
33	CE (0021)	Serial Communication Error	Illuminated	Drive Fault	86
34	bUS (0022)	Option Communication Error	Illuminated	Drive Fault	85
39	EF0 (0027)	Option Card External Fault	Illuminated	Drive Fault	88
41	UL3 (0029)	Undertorque Detection 1	Illuminated	Drive Fault	99
42	UL4 (002A)	Undertorque Detection 2	Illuminated	Drive Fault	99
43	oL7 (002B)	High Slip Braking Overload	Illuminated	Drive Fault	97
54	LF2 (0036)	Output Current Imbalance	Illuminated	Drive Fault	92
59	SEr (003B)	Speed Search Retries Exceeded	Illuminated	Drive Fault	99
66	EF1 (0042)	External Fault (Terminal S1)	Illuminated	Drive Fault	88
67	EF2 (0043)	External Fault (Terminal S2)	Illuminated	Drive Fault	88
70	CoF (0046)	Current Offset Fault	Illuminated	Drive Fault	86
71	PE1 (0047)	PLC Faults	Illuminated	Drive Fault	98
72	PE2 (0048)	PLC Faults	Illuminated	Drive Fault	98
90	UL6 (005A)	Underload or Belt Break Detected	Illuminated	Drive Fault	99
91	dv7 (005B)	Polarity Judge Timeout	Illuminated	Drive Fault	88
129	CPF00 (0081)	Control Circuit Error	Illuminated	Drive Fault	86
130	CPF01 (0082)	Control Circuit Error	Illuminated	Drive Fault	86
131	CPF02 (0083)	A/D Conversion Error	Illuminated	Drive Fault	86
132	CPF03 (0084)	Control Board Connection Error	Illuminated	Drive Fault	86
135	CPF06 (0087)	EEPROM Memory Data Error	Illuminated	Drive Fault	86
136	CPF07 (0088)	Terminal Board Connection Error	Illuminated	Drive Fault	86
137	CPF08 (0089)	Terminal Board Connection Error	Illuminated	Drive Fault	86
140	CPF11 (008C)	RAM Fault	Illuminated	Drive Fault	86
141	CPF12 (008D)	FLASH Memory Fault	Illuminated	Drive Fault	87
142	CPF13 (008E)	Watchdog Circuit Exception	Illuminated	Drive Fault	87
143	CPF14 (008F)	Control Circuit Fault	Illuminated	Drive Fault	87
145	CPF16 (0091)	Clock Fault	Illuminated	Drive Fault	87
146	CPF17 (0092)	Timing Fault	Illuminated	Drive Fault	87
147	CPF18 (0093)	Control Circuit Fault	Illuminated	Drive Fault	87
148	CPF19 (0094)	Control Circuit Fault	Illuminated	Drive Fault	87
149	CPF20 (0095)	Control Circuit Error	Illuminated	Drive Fault	87
150	CPF21 (0096)	Control Circuit Error	Illuminated	Drive Fault	87
151	CPF22 (0097)	Hybrid IC Error	Illuminated	Drive Fault	87
152	CPF23 (0098)	Control Board Connection Error	Illuminated	Drive Fault	87
153	CPF24 (0099)	Drive Unit Signal Fault	Illuminated	Drive Fault	87
155	CPF26 (009B)	BB Circuit Error	Illuminated	Drive Fault	87
156	CPF27 (009C)	PWM Set Reg Error	Illuminated	Drive Fault	87
157	CPF28 (009D)	PWM Pattern Error	Illuminated	Drive Fault	87
158	CPF29 (009E)	On-Delay Error	Illuminated	Drive Fault	87
159	CPF30 (009F)	BB On Error	Illuminated	Drive Fault	87
160	CPF31 (00A0)	ASIC Code Error	Illuminated	Drive Fault	88
161	CPF32 (00A1)	ASIC Startup Error	Illuminated	Drive Fault	88

5 Troubleshooting

Decimal Value	Display (Hex.)	Name	ALM LED	Type	Ref.
162	CPF33 (00A2)	Watch-dog Error	Illuminated	Drive Fault	88
163	CPF34 (00A3)	Power/Clock Error	Illuminated	Drive Fault	88
164	CPF35 (00A4)	Ext A/D Conv Error	Illuminated	Drive Fault	88
165	CPF36 (00A5)	ASIC COM Error	Illuminated	Drive Fault	88
166	CPF37 (00A6)	ASIC COM Error	Illuminated	Drive Fault	88
167	CPF38 (00A7)	EEPROM Data Error	Illuminated	Drive Fault	88
168	CPF39 (00A8)	CPU-ASIC Communication Error	Illuminated	Drive Fault	88
257	oFA00 (0101)	Option Not Compatible with Port	Illuminated	Drive Fault	93
258	oFA01 (0102)	Option Fault/Connection Error	Illuminated	Drive Fault	94
262	oFA05 (0106)	Option A/D Error	Illuminated	Drive Fault	94
263	oFA06 (0107)	Option Communication Error	Illuminated	Drive Fault	94
273	oFA10 (0111)	Option RAM Error	Illuminated	Drive Fault	94
274	oFA11 (0112)	Option Ope Mode Error	Illuminated	Drive Fault	94
275	oFA12 (0113)	Drive Receive CRC Error	Illuminated	Drive Fault	94
276	oFA13 (0114)	Drive Receive Frame Error	Illuminated	Drive Fault	94
277	oFA14 (0115)	Drive Receive Abort Error	Illuminated	Drive Fault	94
278	oFA15 (0116)	Option Receive CRC Error	Illuminated	Drive Fault	94
279	oFA16 (0117)	Option Receive Frame Error	Illuminated	Drive Fault	94
280	oFA17 (0118)	Option Receive Abort Error	Illuminated	Drive Fault	94
305	oFA30 (0131)	COM ID Error	Illuminated	Drive Fault	94
306	oFA31 (0132)	Type Code Error	Illuminated	Drive Fault	94
307	oFA32 (0133)	SUM Check Error	Illuminated	Drive Fault	94
308	oFA33 (0134)	Option Receive Time Over	Illuminated	Drive Fault	94
309	oFA34 (0135)	Memobus Time Over	Illuminated	Drive Fault	94
310	oFA35 (0136)	Drive Receive Time Over 1	Illuminated	Drive Fault	95
311	oFA36 (0137)	CI Check Error	Illuminated	Drive Fault	95
312	oFA37 (0138)	Drive Receive Time Over 2	Illuminated	Drive Fault	95
313	oFA38 (0139)	Control Reference Error	Illuminated	Drive Fault	95
314	oFA39 (013A)	Drive Receive Time Over 3	Illuminated	Drive Fault	95
315	oFA40 (013B)	CtrlResSel 1Err	Illuminated	Drive Fault	95
316	oFA41 (013C)	Drive Receive Time Over 4	Illuminated	Drive Fault	95
317	oFA42 (013D)	CtrlResSel 2Err	Illuminated	Drive Fault	95
318	oFA43 (013E)	Drive Receive Time Over 5	Illuminated	Drive Fault	95
1025	TiM (0401)	Keypad Time Not Set	Illuminated	Drive Fault	99
1026	bAT (0402)	Keypad Battery Low Voltage	Illuminated	Drive Fault	85
1029	ov2 (0405)	DC Bus Overvoltage 2	Illuminated	Drive Fault	98
1039	SCF (040F)	Safety Circuit Fault	Illuminated	Drive Fault	99
1043	FAn1 (0413)	Drive Cooling Fan Fault	Illuminated	Drive Fault	89
1046	bCE (0416)	Bluetooth Communication Fault	Illuminated	Drive Fault	85
1056	AUXFB (0420)	PI Aux Feedback Level Loss	Illuminated	Drive Fault	85
1057	DIFF (0421)	Differential Feedback Exceeded	Illuminated	Drive Fault	88
1058	FDBKL (0422)	WIRE Break	Illuminated	Drive Fault	92
1059	HFB (0423)	High Feedback Sensed	Illuminated	Drive Fault	92

Decimal Value	Display (Hex.)	Name	ALM LED	Type	Ref.
1060	HIAUX (0424)	High PI Aux Feedback Level	Illuminated	Drive Fault	92
1061	LFB (0425)	Low Feedback Sensed	Illuminated	Drive Fault	92
1062	LOAUX (0426)	Low PI Aux Feedback Level	Illuminated	Drive Fault	92
1063	LOP (0427)	Loss of Prime	Illuminated	Drive Fault	92
1065	NMS (0429)	Setpoint Not Met	Illuminated	Drive Fault	93
1066	OD (042A)	Output Disconnect	Illuminated	Drive Fault	93
1067	VLTS (042B)	Thermostat Fault	Illuminated	Drive Fault	99
1079	PSE (0437)	JOHB-SMP3 Protocol set Error	Illuminated	Drive Fault	98
1082	FB02 (043A)	Wait For Interlock Timeout	Illuminated	System Fault	89
1083	FB03 (043B)	External Fault Bypass (EFB)	Illuminated	System Fault	90
1085	FB05 (043D)	Motor Overload	Illuminated	System Fault	90
1086	FB06 (043E)	External Overload 1	Illuminated	System Fault	90
1087	FB07 (043F)	External Overload 2	Illuminated	System Fault	90
1088	FB08 (0440)	Brownout Detected	Illuminated	System Fault	91
1089	FB09 (0441)	Blackout Detected	Illuminated	System Fault	91
1090	FB10 (0442)	Loss of Drive Communications	Illuminated	Drive Fault	91
1093	FB13 (0445)	Loss of Load	Illuminated	System Fault	91
1095	FB15 (0447)	Input Phase Loss	Illuminated	System Fault	91
1096	FB16 (0448)	Input Phase Rotation	Illuminated	System Fault	91
1097	FB17 (0449)	Load Verify Fault	Illuminated	System Fault	91
1098	FB18 (044A)	Welded Bypass Contactor Detected	Illuminated	System Fault	91
1106	FB26 (0452)	Option on Drive Detected	Illuminated	Drive Fault	91
1107	FB27 (0453)	Drive Hardware Fault (CPFx oFx)	Illuminated	Drive Fault	91
1108	FB28 (0454)	Drive Faulted	Illuminated	System Fault	91
1110	FB30 (0456)	Conflicting SW Check UB-99	Illuminated	Drive Fault	91

Table 5.4 List of Minor Faults and Alarms by Decimal

Minor fault and alarm decimal numbers are read in Modbus register 007F.

Decimal Value	Display (Hex.)	Name	ALM LED	Type	Ref.
1	Uv (0001)	DC Bus Undervoltage	Flashing	Alarm	107
2	ov (0002)	DC Bus Overvoltage	Flashing	Alarm	106
3	oH (0003)	Heatsink Overheat	Flashing	Alarm	105
4	oH2 (0004)	External Overheat (H1-XX=B)	Flashing	Alarm	105
5	oL3 (0005)	Overtorque 1	Flashing	Alarm	106
6	oL4 (0006)	Overtorque 2	Flashing	Alarm	106
7	EF (0007)	FWD/REV Run Command Input Error	Flashing	Alarm	102
8	bb (0008)	Baseblock	Flashing	Alarm	100
9	EF3 (0009)	External Fault (Terminal S3)	Flashing	Alarm	102
10	EF4 (000A)	External Fault (Terminal S4)	Flashing	Alarm	102
11	EF5 (000B)	External Fault (Terminal S5)	Flashing	Alarm	102
12	EF6 (000C)	External Fault (Terminal S6)	Flashing	Alarm	103
13	EF7 (000D)	External Fault (Terminal S7)	Flashing	Alarm	103
14	EF8 (000E)	External Fault (Terminal S8)	Flashing	Alarm	103
20	CE (0014)	Serial Communication Error	Flashing	Alarm	101

5 Troubleshooting

Decimal Value	Display (Hex.)	Name	ALM LED	Type	Ref.
21	bBUS (0015)	Option Communication Error	Flashing	Alarm	100
26	EF0 (001A)	Option Card External Fault	Flashing	Alarm	102
29	CALL (001D)	Serial Comm Transmission Error	Flashing	Alarm	101
30	UL3 (001E)	Undertorque Detection 1	Flashing	Alarm	107
31	UL4 (001F)	Undertorque Detection 2	Flashing	Alarm	107
32	SE (0020)	Modbus Test Mode Error	Flashing	Alarm	107
34	oH3 (0022)	Motor Overheat (PTC Input)	Flashing	Alarm	106
41	CyPo (0029)	Cycle Power to Accept Changes	Flashing	Alarm	102
42	dnE (002A)	Drive Disabled	Flashing	Alarm	102
52	HCA (0034)	High Current Alarm	Flashing	Alarm	104
53	LT-1 (0035)	Cooling Fan Maintenance Time	Flashing	Alarm	105
54	LT-2 (0036)	Capacitor Maintenance Time	Flashing	Alarm	105
57	EF1 (0039)	External Fault (Terminal S1)	Flashing	Alarm	102
58	EF2 (003A)	External Fault (Terminal S2)	Flashing	Alarm	102
59	SToF (003B)	Safe Torque OFF	Flashing	Alarm	107
60	STo (003C)	Safe Torque OFF	-	Alarm	107
63	PA1 (003F)	PLC Error 1	Flashing	Alarm	107
66	TrPC (0042)	IGBT Maintenance Time (90%)	Flashing	Alarm	107
67	LT-3 (0043)	SoftChargeBypassRelay MainteTime	Flashing	Alarm	105
68	LT-4 (0044)	IGBT Maintenance Time (50%)	Flashing	Alarm	105
71	PF (0047)	Input Phase Loss	Flashing	Alarm	106
78	UL6 (004E)	Underload or Belt Break Detected	Flashing	Alarm	107
103	EOF (0067)	Emergency Override FWD	Flashing	Alarm	103
104	EOR (0068)	Emergency Override REV	Flashing	Alarm	103
105	INTLK (0069)	BAS Interlock	Flashing	Alarm	104
129	EP24v (0081)	External Power 24V Supply	Flashing	Alarm	103
133	bAT (0085)	Keypad Battery Low Voltage	Flashing	Alarm	100
137	TiM (0089)	Keypad Time Not Set	Flashing	Alarm	107
138	bCE (008A)	Bluetooth Communication Error	Flashing	Alarm	100
144	Bu-Fb (0090)	Main Fdbk Lost Using Backup Fdbk	Flashing	Alarm	100
145	BuFbl (0091)	Backup Fdbk Lost Chk/Repl Xducer	Flashing	Alarm	100
146	CE (0092)	Run at H5-34 (CE Go-To-Freq)	Flashing	Alarm	101
147	DIFF (0093)	Differential Feedback Exceeded	Flashing	Alarm	102
148	FDBKL (0094)	Feedback Loss Wire Break	Flashing	Alarm	103
149	FLGT (0095)	Feedback Loss, Go To Freq b5-83	Flashing	Alarm	103
150	HIAUX (0096)	High PI Aux Feedback Level	Flashing	Alarm	104
151	HIFB (0097)	High Feedback Sensed	Flashing	Alarm	104
153	LOAUX (0099)	Low PI Aux Feedback Level	Flashing	Alarm	104
154	LOFB (009A)	Low Feedback Sensed	Flashing	Alarm	104
155	LOP (009B)	Loss of Prime	Flashing	Alarm	105
156	NMS (009C)	Setpoint Not Met	Flashing	Alarm	105
157	OD (009D)	Output Disconnect	Flashing	Alarm	105
158	FR<MS (009E)	Freq Ref < Minimum Speed (Y1-06)	Flashing	Alarm	103

Decimal Value	Display (Hex.)	Name	ALM LED	Type	Ref.
159	FR<TH (009F)	Freq. Reference < Thrust (Y4-12)	Flashing	Alarm	104
162	AFBL (00A2)	Analog Fbk Lost, Switched to Net	Flashing	Alarm	100
163	AuDis (00A3)	Low PI Aux Fdbk Drive Disabled	Flashing	Alarm	100
164	AUXFB (00A4)	PI Aux Feedback Level Loss	Flashing	Alarm	100
165	AuFbl (00A5)	PI Aux Fdbk Lost Switched to Net	Flashing	Alarm	100
166	BuDif (00A6)	Main Fdbk Lost, Using Diff Fdbk	Flashing	Alarm	100
167	LCP (00A7)	Low City Pressure	Flashing	Alarm	104
168	LSP (00A8)	Low Suction Pressure	Flashing	Alarm	105
169	LWT (00A9)	Low Water In Tank	Flashing	Alarm	105
178	AL02 (00B2)	Interlock Open	Flashing	Alarm	100
179	AL03 (00B3)	Emergency Override Bypass	Flashing	Alarm	100
185	AL09 (00B9)	Restart Delay Active	Flashing	Alarm	100
189	AL13 (00BD)	Loss of Load Detected	Flashing	Alarm	100
192	AL16 (00C0)	Input Phase Rotation	Flashing	Alarm	100
193	AL17 (00C1)	Remote Xfer disabled in Reverse	Flashing	Alarm	100
194	AL18 (00C2)	Auto Xfer disabled in Reverse	Flashing	Alarm	100
198	HWL (00C6)	High Water Level	Flashing	Alarm	104
208	LWL (00D0)	Low Water Level	Flashing	Alarm	105
201	SAFE (00C9)	Safety Open	Flashing	Alarm	107
202	FIRE_ST (00CA)	Fire Stat Open	Flashing	Alarm	103
203	FREEZ_ST (00CB)	Freeze Stat Open	Flashing	Alarm	103
204	SMK_ALRM (00CC)	Smoke Alarm Active	Flashing	Alarm	107
205	OV_PRESS (00CD)	Over Pressure Detected	Flashing	Alarm	106
206	LOW_SUCT (00CE)	Low Suction Detected	Flashing	Alarm	105
207	VBRATION (00CF)	Vibration Detected	Flashing	Alarm	108

◆ Faults

This section gives information about some of the causes and possible solutions of faults. You must use the Fault Reset operation to remove the fault before you can operate the drive. Use the information in this table to remove the cause of the fault.

Code	Name	Causes	Possible Solutions
AUXFB	PI Aux Feedback Level Loss	The analog input from the terminal set for <i>PI Auxiliary Control Feedback Level [H3-xx = 27]</i> is more than 21 mA or less than 3 mA for longer than 1 s.	Repair transducer or wiring.
bAT	Keypad Battery Low Voltage	The keypad battery voltage is low.	Replace the keypad battery.
bCE	Bluetooth Communication Fault	The smartphone or tablet with DriveWizard Mobile installed is too far from the keypad.	Use the smartphone or tablet 10 m (32.8 ft) or nearer to the keypad. Note: <i>bCE</i> can occur when the smartphone or tablet is 10 m (32.8 ft) or nearer to the keypad depending on the specifications of the smartphone or tablet.
		Radio waves from a different device are causing interference with communications between the smartphone or tablet and keypad.	Make sure that no device around the keypad uses the same radio bandwidth (2400 MHz to 2480 MHz), and prevent radio interference.
bUS	Option Communication Error	The drive did not receive a signal from the controller.	Correct wiring errors.
		The communications cable wiring is incorrect.	
		There is a short-circuit in the communications cable or the communications cable is not connected.	<ul style="list-style-type: none"> Repair short circuits and connect cables. Replace the defective communications cable.

5 Troubleshooting

Code	Name	Causes	Possible Solutions
		Electrical interference caused a communication data error.	<ul style="list-style-type: none"> Examine the control circuit lines, main circuit lines, and ground wiring, and decrease the effects of electrical interference. Make sure that a magnetic contactor is not the source of the electrical interference, then use a Surge Protective Device if necessary. Use only the recommended cables or other shielded line. Ground the shield on the controller side or the drive input power side. Separate the communication wiring from drive power lines, and install a noise filter to the input side of the power supply for communication. Decrease the effects of electrical interference from the controller.
		The option is incorrectly installed to Bypass PCB A2.	Correctly install the option to Bypass PCB A2.
		The option is damaged.	If the fault continues and the wiring is correct, replace the option.
CE	Serial Communication Error	The communications cable wiring is incorrect.	Correct wiring errors.
		There is a short circuit in the communications cable or the communications cable is not connected.	<ul style="list-style-type: none"> Repair short circuits and connect cables. Replace the defective communications cable.
		Electrical interference caused a communication data error.	<ul style="list-style-type: none"> Examine the control circuit lines, main circuit lines, and ground wiring, and decrease the effects of electrical interference. Make sure that a magnetic contactor is not the source of the electrical interference, then use a Surge Protective Device if necessary. Use only the recommended cables or other shielded line. Ground the shield on the controller side or the drive input power side. Separate the communication wiring from drive power lines, and install a noise filter to the input side of the power supply for communication. Decrease the effects of electrical interference from the controller.
CoF	Current Offset Fault	The drive starts operation while the induced voltage stays in the motor (during coasting to a stop or after fast deceleration).	<ul style="list-style-type: none"> Make a sequence that does not restart operation when induced voltage stays in the motor. Set $b3-01 = 1$ [<i>Speed Search at Start Selection = Enabled</i>]. Use <i>Speed Search from Fmax or Fref</i> [$H1-xx = 61, 62$] to do a speed search through one of the external terminals.
		A drive hardware problem occurred.	Replace the drive.
CPF00	Control Circuit Error	A drive hardware problem occurred.	<ul style="list-style-type: none"> Re-energize the drive. If the fault stays, replace the control board or the drive. For information about replacing the control board, contact Yaskawa or your nearest sales representative.
CPF01	Control Circuit Error	A drive hardware problem occurred.	<ul style="list-style-type: none"> Re-energize the drive. If the fault stays, replace the control board or the drive. For information about replacing the control board, contact Yaskawa or your nearest sales representative.
CPF02	A/D Conversion Error	A drive hardware problem occurred.	<ul style="list-style-type: none"> Re-energize the drive. If the fault stays, replace the control board or the drive. For information about replacing the control board, contact Yaskawa or your nearest sales representative.
CPF03	Control Board Connection Error	A drive hardware problem occurred.	<ul style="list-style-type: none"> Re-energize the drive. If the fault stays, replace the control board or the drive. For information about replacing the control board, contact Yaskawa or your nearest sales representative.
CPF06	EEPROM Memory Data Error	The drive power supply was de-energized while a communication option card entered a parameter Write command.	Set $A1-03 = 2220$ [<i>Initialize Parameters = 2-Wire Initialization</i>] and initialize the drive.
		An EEPROM peripheral circuit error occurred.	<ul style="list-style-type: none"> Re-energize the drive. If the fault stays, replace the control board or the drive. For information about replacing the control board, contact Yaskawa or your nearest sales representative.
CPF07	Terminal Board Connection Error	A drive hardware problem occurred.	<ul style="list-style-type: none"> Re-energize the drive. If the fault stays, replace the control board or the drive. For information about replacing the control board, contact Yaskawa or your nearest sales representative.
CPF08	Terminal Board Connection Error	A drive hardware problem occurred.	<ul style="list-style-type: none"> Re-energize the drive. If the fault stays, replace the control board or the drive. For information about replacing the control board, contact Yaskawa or your nearest sales representative.
CPF11	RAM Fault	A drive hardware problem occurred.	<ul style="list-style-type: none"> Re-energize the drive. If the fault stays, replace the control board or the drive. For information about replacing the control board, contact Yaskawa or your nearest sales representative.

Code	Name	Causes	Possible Solutions
CPF12	FLASH Memory Fault	A drive hardware problem occurred.	<ul style="list-style-type: none"> Re-energize the drive. If the fault stays, replace the control board or the drive. For information about replacing the control board, contact Yaskawa or your nearest sales representative.
CPF13	Watchdog Circuit Exception	A drive hardware problem occurred.	<ul style="list-style-type: none"> Re-energize the drive. If the fault stays, replace the control board or the drive. For information about replacing the control board, contact Yaskawa or your nearest sales representative.
CPF14	Control Circuit Fault	A drive hardware problem occurred.	<ul style="list-style-type: none"> Re-energize the drive. If the fault stays, replace the control board or the drive. For information about replacing the control board, contact Yaskawa or your nearest sales representative.
CPF16	Clock Fault	A drive hardware problem occurred.	<ul style="list-style-type: none"> Re-energize the drive. If the fault stays, replace the control board or the drive. For information about replacing the control board, contact Yaskawa or your nearest sales representative.
CPF17	Timing Fault	A drive hardware problem occurred.	<ul style="list-style-type: none"> Re-energize the drive. If the fault stays, replace the control board or the drive. For information about replacing the control board, contact Yaskawa or your nearest sales representative.
CPF18	Control Circuit Fault	A drive hardware problem occurred.	<ul style="list-style-type: none"> Re-energize the drive. If the fault stays, replace the control board or the drive. For information about replacing the control board, contact Yaskawa or your nearest sales representative.
CPF19	Control Circuit Fault	A drive hardware problem occurred.	<ul style="list-style-type: none"> Re-energize the drive and check if the fault still remains. Replace the control board or the entire drive if the fault continues. Contact Yaskawa or your nearest sales representative for instructions on replacing the control board.
CPF20	Control Circuit Error	A drive hardware problem occurred.	<ul style="list-style-type: none"> Re-energize the drive. If the fault stays, replace the control board or the drive. For information about replacing the control board, contact Yaskawa or your nearest sales representative.
CPF21	Control Circuit Error	A drive hardware problem occurred.	<ul style="list-style-type: none"> Re-energize the drive. If the fault stays, replace the control board or the drive. For information about replacing the control board, contact Yaskawa or your nearest sales representative.
CPF22	Hybrid IC Error	A drive hardware problem occurred.	<ul style="list-style-type: none"> Re-energize the drive. If the fault stays, replace the control board or the drive. For information about replacing the control board, contact Yaskawa or your nearest sales representative.
CPF23	Control Board Connection Error	A drive hardware problem occurred.	<ul style="list-style-type: none"> Re-energize the drive. If the fault stays, replace the control board or the drive. For information about replacing the control board, contact Yaskawa or your nearest sales representative.
CPF24	Drive Unit Signal Fault	A drive hardware problem occurred.	<ul style="list-style-type: none"> Re-energize the drive. If the fault stays, replace the control board or the drive. For information about replacing the control board, contact Yaskawa or your nearest sales representative.
CPF26	BB Circuit Error	A drive hardware problem occurred.	<ul style="list-style-type: none"> Re-energize the drive. If the fault stays, replace the control board or the drive. For information about replacing the control board, contact Yaskawa or your nearest sales representative.
CPF27	PWM Set Reg Error	A drive hardware problem occurred.	<ul style="list-style-type: none"> Re-energize the drive. If the fault stays, replace the control board or the drive. For information about replacing the control board, contact Yaskawa or your nearest sales representative.
CPF28	PWM Pattern Error	A drive hardware problem occurred.	<ul style="list-style-type: none"> Re-energize the drive. If the fault stays, replace the control board or the drive. For information about replacing the control board, contact Yaskawa or your nearest sales representative.
CPF29	On-Delay Error	A drive hardware problem occurred.	<ul style="list-style-type: none"> Re-energize the drive. If the fault stays, replace the control board or the drive. For information about replacing the control board, contact Yaskawa or your nearest sales representative.
CPF30	BB On Error	A drive hardware problem occurred.	<ul style="list-style-type: none"> Re-energize the drive. If the fault stays, replace the control board or the drive. For information about replacing the control board, contact Yaskawa or your nearest sales representative.

5 Troubleshooting

Code	Name	Causes	Possible Solutions
CPF31	ASIC Code Error	A drive hardware problem occurred.	<ul style="list-style-type: none"> Re-energize the drive. If the fault stays, replace the control board or the drive. For information about replacing the control board, contact Yaskawa or your nearest sales representative.
CPF32	ASIC Startup Error	A drive hardware problem occurred.	<ul style="list-style-type: none"> Re-energize the drive. If the fault stays, replace the control board or the drive. For information about replacing the control board, contact Yaskawa or your nearest sales representative.
CPF33	Watch-dog Error	A drive hardware problem occurred.	<ul style="list-style-type: none"> Re-energize the drive. If the fault stays, replace the control board or the drive. For information about replacing the control board, contact Yaskawa or your nearest sales representative.
CPF34	Power/Clock Error	A drive hardware problem occurred.	<ul style="list-style-type: none"> Re-energize the drive. If the fault stays, replace the control board or the drive. For information about replacing the control board, contact Yaskawa or your nearest sales representative.
CPF35	Ext A/D Conv Error	A drive hardware problem occurred.	<ul style="list-style-type: none"> Re-energize the drive. If the fault stays, replace the control board or the drive. For information about replacing the control board, contact Yaskawa or your nearest sales representative.
CPF36	ASIC COM Error	A drive hardware problem occurred.	<ul style="list-style-type: none"> Re-energize the drive. If the fault stays, replace the control board or the drive. For information about replacing the control board, contact Yaskawa or your nearest sales representative.
CPF37	ASIC COM Error	A drive hardware problem occurred.	<ul style="list-style-type: none"> Re-energize the drive. If the fault stays, replace the control board or the drive. For information about replacing the control board, contact Yaskawa or your nearest sales representative.
CPF38	EEPROM Memory Data Error	A drive hardware problem occurred.	<ul style="list-style-type: none"> Re-energize the drive. If the fault stays, replace the control board or the drive. For information about replacing the control board, contact Yaskawa or your nearest sales representative.
CPF39	CPU-ASIC Communication Error	A drive hardware problem occurred.	<ul style="list-style-type: none"> Re-energize the drive. If the fault stays, replace the control board or the drive. For information about replacing the control board, contact Yaskawa or your nearest sales representative.
dEv	Speed Deviation	The load is too heavy.	Decrease the load.
		Acceleration and deceleration times are set too short.	Increase the values set in C1-01 to C1-04 [Acceleration/Deceleration Time].
		The dEv detection level settings are incorrect.	Adjust F1-10 [Speed Deviation Detection Level] and F1-11 [Speed Deviation Detect DelayTime].
		The load is locked up.	Examine the machine.
		The holding brake is stopping the motor.	Release the holding brake.
DIFF	Differential Feedback Exceeded	The difference between the PID Feedback and Differential Level Source [H3-xx = 2D] is more than the level set in Y4-18 [Differential Level] for the time set in Y4-19 [Differential Lvl Detection Time].	<ul style="list-style-type: none"> Replace the feedback transducer or transducers. Make sure that the settings of Y4-18 [Differential Level] to Y4-20 [Differential Level Detection Sel] are correct.
dv7	Polarity Judge Timeout	There is a disconnection in the motor coil winding.	Measure the motor line-to-line resistance and replace the motor if a coil is disconnected.
		The screws on the drive output terminals are loose.	Tighten the terminal screws to the correct tightening torque.
EF0	Option Card External Fault	The communication option received an external fault from the controller.	<ol style="list-style-type: none"> Find the device that caused the external fault and remove the cause. Clear the external fault input from the controller.
		A programming error occurred on the controller side.	Examine the operation of the controller program.
EF1	External Fault (Terminal S1)	MFDI terminal S1 caused an external fault through an external device.	<ol style="list-style-type: none"> Find the device that caused the external fault and remove the cause. Clear the external fault input in the MFDI.
		The wiring is incorrect.	Correctly connect the signal line to MFDI terminal S1.
		External Fault [H1-01 = 20 to 2B] is set to MFDI terminal S1, but the terminal is not in use.	Correctly set the MFDI.
EF2	External Fault (Terminal S2)	MFDI terminal S2 caused an external fault through an external device.	<ol style="list-style-type: none"> Find the device that caused the external fault and remove the cause. Clear the external fault input in the MFDI.
		The wiring is incorrect.	Correctly connect the signal line to MFDI terminal S2.

Code	Name	Causes	Possible Solutions
		<i>External Fault [H1-02 = 20 to 2B]</i> is set to MFDI terminal S2, but the terminal is not in use.	Correctly set the MFDI.
EF3	External Fault (Terminal S3)	MFDI terminal S3 caused an external fault through an external device.	1. Find the device that caused the external fault and remove the cause. 2. Clear the external fault input in the MFDI.
		The wiring is incorrect.	Correctly connect the signal line to MFDI terminal S3.
		<i>External Fault [H1-03 = 20 to 2B]</i> is set to MFDI terminal S3, but the terminal is not in use.	Correctly set the MFDI.
EF4	External Fault (Terminal S4)	MFDI terminal S4 caused an external fault through an external device.	1. Find the device that caused the external fault and remove the cause. 2. Clear the external fault input in the MFDI.
		The wiring is incorrect.	Correctly connect the signal line to MFDI terminal S4.
		<i>External Fault [H1-04 = 20 to 2B]</i> is set to MFDI terminal S4, but the terminal is not in use.	Correctly set the MFDI.
EF5	External Fault (Terminal S5)	MFDI terminal S5 caused an external fault through an external device.	1. Find the device that caused the external fault and remove the cause. 2. Clear the external fault input in the MFDI.
		The wiring is incorrect.	Correctly connect the signal line to MFDI terminal S5.
		<i>External Fault [H1-05 = 20 to 2B]</i> is set to MFDI terminal S5, but the terminal is not in use.	Correctly set the MFDI.
EF6	External Fault (Terminal S6)	MFDI terminal S6 caused an external fault through an external device.	1. Find the device that caused the external fault and remove the cause. 2. Clear the external fault input in the MFDI.
		The wiring is incorrect.	Correctly connect the signal line to MFDI terminal S6.
		<i>External Fault [H1-06 = 20 to 2B]</i> is set to MFDI terminal S6, but the terminal is not in use.	Correctly set the MFDI.
EF7	External Fault (Terminal S7)	MFDI terminal S7 caused an external fault through an external device.	1. Find the device that caused the external fault and remove the cause. 2. Clear the external fault input in the MFDI.
		The wiring is incorrect.	Correctly connect the signal line to MFDI terminal S7.
		<i>External Fault [H1-07 = 20 to 2B]</i> is set to MFDI terminal S7, but the terminal is not in use.	Correctly set the MFDI.
EF8	External Fault (Terminal S8)	MFDI terminal S8 caused an external fault through an external device.	1. Find the device that caused the external fault and remove the cause. 2. Clear the external fault input in the MFDI.
		The wiring is incorrect.	Correctly connect the signal line to MFDI terminal S8.
		<i>External Fault [H1-08 = 20 to 2B]</i> is set to MFDI terminal S8, but the terminal is not in use.	Correctly set the MFDI.
Err	EEPROM Write Error	There was a problem with the EEPROM hardware.	<ul style="list-style-type: none"> Re-energize the drive. If the fault stays, replace the control board or the drive. Contact Yaskawa or your nearest sales representative to replace the board.
		Electrical interference corrupted the data while it was writing to the EEPROM of the drive.	<ul style="list-style-type: none"> Push ENTER Key. Set the parameters again.
FAn1	Drive Cooling Fan Fault	The cooling fan stopped operating correctly.	<ul style="list-style-type: none"> Examine cooling fan operation. Re-energize the drive. Examine U4-03 [Cooling Fan Ope Time] and U4-04 [Cool Fan Maintenance]. If the performance life of the cooling fan is expired or if there is damage to the fan, replace the fan.
		The circulation fan is damaged.	<ul style="list-style-type: none"> Examine circulation fan operation. Re-energize the drive. Examine U4-03 [Cooling Fan Ope Time] and U4-04 [Cool Fan Maintenance]. If there is damage to the circulation fan or if the performance life of the fan is expired, replace the fan.
FB02	Wait For Interlock Timeout	The digital input set to Run Interlock is open. This will usually be Terminal TB2-3 on Bypass PCB A2.	<ul style="list-style-type: none"> Install a NC BAS Interlock Circuit/Damper Interlock between TB2-3 and TB2-9 on Bypass PCB A2. Install a jumper between TB2-3 and TB2-9 on Bypass PCB A2. Use this method when you will add a BAS (Building Automation System) Interlock circuit in the future or if you will not use a BAS interlock circuit. Make sure that the input assigned for the Interlock is active in the timeout period set in Z1-15.

5 Troubleshooting

Code	Name	Causes	Possible Solutions
FB03	External Fault Bypass (EFB)	An digital input set for external fault (EFB) was activated.	Remove the cause of the external fault.
		An external fault (EFB) was received from the serial communications network.	<ul style="list-style-type: none"> Remove the cause of the external fault. Remove the external fault input from the controller. Make sure that the controller program is correct.
FB05	Motor Overload	The load is too heavy.	Decrease the load. Note: You can reset <i>FB05</i> only when <i>U4-16 [Motor oL1 Level] < 100</i> .
		The acceleration/deceleration times or cycle times are too short.	<ul style="list-style-type: none"> Examine the acceleration/deceleration times and the motor start/stop frequencies (cycle times). Increase the values set in <i>C1-01</i> to <i>C1-04 [Acceleration/Deceleration Times]</i>.
		Overload occurred while running at low speed.	<ul style="list-style-type: none"> Decrease the load when running at low speed. Increase the motor speed. If the motor is run frequently at low speeds, replace the motor with a larger motor or use a drive-dedicated motor. Note: For general-purpose motors, overload can occur while running at low speed when operating at below the rated current.
		Starting the motor too often in Bypass Mode.	Decrease the number of times the motor is started in Bypass Mode.
		The V/f pattern does not fit the motor qualities.	<ul style="list-style-type: none"> Examine the ratios between the V/f pattern frequency and voltage. Decrease the voltage if it is too high compared to the frequency. Adjust <i>E1-04</i> to <i>E1-10 [V/f Pattern Parameters]</i>. Decrease the values set in <i>E1-08 [Mid Point A Voltage]</i> and <i>E1-10 [Minimum Output Voltage]</i>. Note: If the values set in <i>E1-08</i> and <i>E1-10</i> are too low, the overload tolerance will decrease at low speeds.
		<i>E1-06 [Base Frequency]</i> is set incorrectly.	Set <i>E1-06</i> to the rated frequency shown on the motor nameplate.
		One drive is operating more than one motor.	Set <i>L1-01 = 0 [Motor Overload (oL1) Protection = Disabled]</i> , connect thermal overload relay to each motor to prevent damage to the motors.
		The electronic thermal protector is operating at an incorrect level.	<ul style="list-style-type: none"> Set <i>E2-01 [Motor Rated Current (FLA)]</i> correctly to the value specified by the motor nameplate. Make sure that <i>L1-08 [oL1 Current level] = 0.00 A</i> or to the correct value as specified by the motor nameplate.
		There is increased motor loss from overexcitation operation.	<ul style="list-style-type: none"> Lower the value set in <i>n3-13 [OverexcitationBraking (OEB) Gain]</i>. Set <i>L3-04 ≠ 4 [Stall Prevention during Decel ≠ Overexcitation/High Flux]</i>. Set <i>n3-23 = 0 [Overexcitation Braking Operation = Disabled]</i>.
		The speed search-related parameters are set incorrectly.	<ul style="list-style-type: none"> Examine the settings for all speed search related parameters. Adjust <i>b3-03 [Speed Search Deceleration Time]</i>. Set <i>b3-24 = 1 [Speed Search Method Selection = Speed Estimation]</i> after Auto-Tuning.
Phase loss in the input power supply is causing the output current to change.	Make sure that there is no phase loss, and repair problems.		
Overload occurred during overexcitation deceleration.	<ul style="list-style-type: none"> Decrease the value set in <i>n3-13 [OverexcitationBraking (OEB) Gain]</i>. Decrease the value set in <i>n3-21 [HSB Current Suppression Level]</i>. 		
FB06	External Overload 1	The load is too heavy.	Decrease the load.
		The cycle times for acceleration and deceleration are too short.	Increase the acceleration and deceleration times in <i>C1-01</i> and <i>C1-02</i> .
		The external motor overload is set incorrectly.	Adjust the dial on the external motor overload to align with the motor nameplate rating.
		External motor overload wiring error.	Make sure that the wiring is correct between the normally-closed control contacts on the external motor overload and the digital input [<i>Z2-0x</i>] programmed to 29 [<i>External Overload Motor 1 (NC)</i>].
FB07	External Overload 2	The load is too heavy.	Decrease the load.
		The cycle times for acceleration and deceleration are too short.	Increase the acceleration and deceleration times in <i>C1-01</i> and <i>C1-02</i> .
		The external motor overload is set incorrectly.	Adjust the dial on the external motor overload to align with the motor nameplate rating.

Code	Name	Causes	Possible Solutions				
		External motor overload wiring error.	Make sure that the wiring is correct between the normally-closed control contacts on the external motor overload and the digital input [Z2-0x] programmed to 30 [External Overload Motor 2 (NC)].				
FB08	Brownout Detected	Input power is too low.	Make sure that the input power is sufficient to power the bypass.				
		The brownout settings are incorrect.	Make sure that Z1-27 [Brownout Voltage Level] and Z1-28 [Brownout Time] are correct.				
FB09	Blackout Detected	Input power is too low.	Make sure that the input power is sufficient to power the bypass.				
		The blackout settings are incorrect.	<ul style="list-style-type: none"> Make sure that Z1-29 [Blackout Voltage Level] is correct. Set Z1-60 ≠ 0 [Blackout Operation Select ≠ Fault]. 				
FB10	Loss of Drive Communications	The cable between the bypass controller and the drive is disconnected or damaged.	Make sure that the cable between the bypass controller board (A2) connector CN6 to drive terminal CN6 is connected at both ends and is not damaged.				
		The drive does not have power (look at the CHARGE LED to verify).	<ul style="list-style-type: none"> If equipped, check the drive input disconnect switch, the drive input fuses, and/or correct operation of the K1 input contactor. Switch the system into Bypass Mode. 				
		The bypass controller circuit is defective.	Replace the bypass control board.				
		The drive circuitry is defective.	Replace the drive.				
FB13	Loss of Load	The motor is disconnected from the drive	Check the continuity between the drive/bypass and the motor.				
		The load is disconnected from the motor.	Check the belt/coupling between the motor and the load.				
		The Loss of Load settings are incorrect.	Make sure that the settings in Z1-31 to Z1-36 are correct.				
FB15	Input Phase Loss	Bypass Mode current unbalance condition is more than the unbalance level limit in Z1-50 for the length of time in Z1-51.	<ul style="list-style-type: none"> Make sure that the input wiring including fuses, breakers, and connections upstream from the bypass is correct. Make sure that the motor wiring and connections are correct. To disable this fault, set Z1-51 [Bypass Input Phase Loss Delay] to 0.0 sec. 				
FB16	Input Phase Rotation	Incorrect phase rotation while Z1-52 = 2 in Bypass Mode.	<ul style="list-style-type: none"> Make sure that the sequence (phase rotation) of the input wiring to the bypass package is correct. To disable this fault, set Z1-52 [Input Phase Rotation Detection] to 0 or 1 				
FB17	Load Verify Fault	The drive or bypass output current is less than 5% of E2-01, Motor Rated Current for longer than 10 seconds.	<ul style="list-style-type: none"> Close all external output disconnects. Make sure that the frequency reference or PID output > 0. Check motor wiring. Set d2-02 > 0.0% To disable this fault, set Z1-53 = 0 [Load Verify Detection = Disabled]. 				
FB18	Welded Bypass Contactor Detected	The bypass detected a welded contactor condition.	Inspect the K3 bypass contactor.				
FB26	Option on Drive Detected	There is a communications option PCB connected to the CN5 port on the drive.	Remove the option PCB from the drive and install it in the CN5 port of the bypass controller.				
FB27	Drive Hardware Fault (CPFx oFx)	There is a CPFxx or oFA fault on the drive.	Remove the cause of the fault on the drive.				
FB28	Drive Faulted	Generic fault code to identify a drive fault that was duplicated or not detected by the bypass.	Investigate and remove the cause of the drive fault.				
FB30	Conflicting SW Check UB-99	<p>The bypass controller software version does not align with the drive software version.</p> <p>The bypass controller firmware is for a different drive series than FP605. You can see the drive series on the keypad during a power-up sequence (splash screen).</p>	<p>Do ONE of these solutions:</p> <ol style="list-style-type: none"> Update the firmware in the drive to align with what is displayed in bypass monitor Ub-99 (set A1-01 = 3 to be able to view this monitor). Update the firmware in the bypass controller to one that aligns with the firmware in the drive as listed in the table below: <table border="1" data-bbox="1047 1535 1523 1665"> <thead> <tr> <th>Drive Software (Read from U1-25)</th> <th>Applicable Bypass Controller Firmware Version:</th> </tr> </thead> <tbody> <tr> <td>01012</td> <td>00560</td> </tr> </tbody> </table> Disable firmware version checking. Set Z1-98 or Z1-99 so that $Z1-98 \leq U1-25 \leq Z1-99$. (set A1-01 = 3 to be able to change these parameters). Refer to the Z1-99 [Maximum Drive SW Ver] Parameter Details description in the Technical Reference for more information. 	Drive Software (Read from U1-25)	Applicable Bypass Controller Firmware Version:	01012	00560
Drive Software (Read from U1-25)	Applicable Bypass Controller Firmware Version:						
01012	00560						

5 Troubleshooting

Code	Name	Causes	Possible Solutions
FDBKL	WIRE Break	The analog input from the terminal set for <i>PID Feedback [H3-xx = B]</i> is more than 21mA or less than 3mA for longer than 1 s in these conditions: <ul style="list-style-type: none"> • <i>b5-82 = 2 [Feedback Loss 4 ~ 20mA Detect Sel = Fault]</i> • <i>b5-01 ≠ 0 [PID Mode Setting ≠ Disabled]</i> • <i>H3-01 or H3-09 = 2 [Terminal A1/A2 Signal Level Selection = 4 to 20 mA]</i> 	Make sure that you install the PID feedback source and it operates correctly.
GF	Ground Fault	Overheating caused damage to the motor or the motor insulation is not satisfactory.	Measure the motor insulation resistance, and replace the motor if there is electrical conduction or unserviceable insulation.
		The motor main circuit cable is contacting ground to make a short circuit.	<ul style="list-style-type: none"> • Examine the motor main circuit cable for damage, and repair short circuits. • Measure the resistance between the motor main circuit cable and the ground terminal. If there is electrical conduction, replace the cable.
		An increase in the stray capacitance of the cable and the ground terminal caused an increase in the leakage current.	<ul style="list-style-type: none"> • If the wiring length of the cable is more than 100 m, decrease the carrier frequency. • Decrease the stray capacitance.
		There was a problem with the drive hardware.	Replace the control board or the drive. For information about replacing the control board, contact Yaskawa or your nearest sales representative.
HFB	High Feedback Sensed	The feedback level is more than the level set in <i>Y1-11 [High Feedback Level]</i> for the time set in <i>Y1-12 [High Feedback Lvl Fault Dly Time]</i> .	<ul style="list-style-type: none"> • Decrease the feedback level less than <i>Y1-11</i>. • Set <i>Y1-11</i> and <i>Y1-12</i> correctly.
HIAUX	High PI Aux Feedback Level	PI Auxiliary Feedback is more than the level set in <i>YF-12 [PI Aux Control High Level Detect]</i> for the time set in <i>YF-13 [PI Aux High Level Detection Time]</i> in these conditions: <ul style="list-style-type: none"> • The drive operates in AUTO Mode. • The output frequency > 0. 	<ul style="list-style-type: none"> • Decrease the PI Auxiliary Feedback level less than <i>YF-12</i>. • Set <i>YF-12</i> and <i>YF-13</i> correctly.
LF	Output Phase Loss	The motor main circuit cable is disconnected.	Connect motor main circuit cable wiring. Correct wiring errors in the main circuit drive input power.
		There is a disconnection in the motor coil winding.	If a coil is disconnected, measure the motor Line-to-Line Resistance and replace the motor.
		The screws on the drive output terminals are loose.	Tighten the terminal screws to the correct tightening torque.
		The rated current of the motor is less than 5% of the drive rated output current.	Examine the drive capacity or the motor output to be applied.
		You are trying to use a single-phase motor.	The drive cannot operate a single-phase motor.
		The output transistor in the drive is damaged.	<ul style="list-style-type: none"> • Re-energize the drive. • If the fault stays, replace the control board or the drive. For information about replacing the control board, contact Yaskawa or your nearest sales representative.
		One of the output contactors K2 (K4 or K5, if equipped) is defective.	Contact Yaskawa or your nearest sales representative.
LF2	Output Current Imbalance	Phase loss occurred in the wiring on the output side of the drive.	Examine for wiring errors or disconnected wires on the output side of the drive, and repair problems.
		The output terminal screws of the drive are loose.	Tighten the terminal screws to the correct tightening torque.
		The drive output circuit is broken.	<ul style="list-style-type: none"> • Re-energize the drive. • If the fault stays, replace the control board or the drive. For information about replacing the control board, contact Yaskawa or your nearest sales representative.
LFB	Low Feedback Sensed	The feedback level is less than the level set in <i>Y1-08 [Low Feedback Level]</i> for the time set in <i>Y1-09 [Low Feedback Lvl Fault Dly Time]</i> .	<ul style="list-style-type: none"> • Increase the feedback level to more than <i>Y1-08</i>. • Set <i>Y1-08</i> and <i>Y1-09</i> correctly.
LOAUX	Low PI Aux Feedback Level	When the drive operates in AUTO Mode or HAND Mode, PI Auxiliary Feedback is less than the level set in <i>YF-09 [PI Aux Control Low Lvl Detection]</i> for the time set in <i>YF-10 [PI Aux Control Low Lvl Det Time]</i> and the drive is running.	<ul style="list-style-type: none"> • Increase the PI Auxiliary Feedback level to be more than <i>YF-09</i>. • Set <i>YF-09</i> and <i>YF-10</i> correctly.
LOP	Loss of Prime	The drive used the <i>Y1-18 [Prime Loss Detection Method]</i> setting and measured a pump load that is less than the level set in <i>Y1-19 [Prime Loss Level]</i> for the time set in <i>Y1-20 [Prime Loss Time]</i> , and the output frequency is <i>Y1-21 [Prime Loss Activation Freq]</i> or more.	<ul style="list-style-type: none"> • Examine for a dry well, air in the system, or no water in the system. Use preferred priming method suggested by the pump manufacturer to restart the pump. • When there is resistance in the pump, let the system pump water again. • Set <i>Y1-18</i> to <i>Y1-21</i> correctly.

Code	Name	Causes	Possible Solutions
NMS	Setpoint Not Met	The feedback deviates from the setpoint at a level more than <i>Y1-15 [Maximum Setpoint Difference]</i> for the time set in <i>Y1-16 [Not Maintaining Setpoint Time]</i> .	<ul style="list-style-type: none"> Examine for a blocked impeller, over cycling, or broken pipe. Set <i>Y1-15</i> and <i>Y1-16</i> correctly.
oC	Overcurrent	The load is too large.	<ul style="list-style-type: none"> Measure the current flowing into the motor. Replace the drive with a larger capacity model if the current value is more than the drive rated current. Decrease the load or replace with a larger drive to prevent sudden changes in the current level.
		Overheating caused damage to the motor or the motor insulation is not satisfactory.	Measure the motor insulation resistance, and replace the motor if there is electrical conduction or unserviceable insulation.
		The motor main circuit cable is contacting ground to make a short circuit.	<ul style="list-style-type: none"> Examine the motor main circuit cable for damage, and repair short circuits. Measure the resistance between the motor main circuit cable and the ground terminal. If there is electrical conduction, replace the cable.
		A short circuit or ground fault on the drive output side caused damage to the output transistor of the drive.	<ul style="list-style-type: none"> Make sure that there is not a short circuit in terminals - and terminals U/T1, V/T2, and W/T3. If there is a short circuit, contact Yaskawa or your nearest sales representative.
		The acceleration time is too short.	<ul style="list-style-type: none"> Calculate the torque necessary during acceleration related to the load inertia and the specified acceleration time. Increase the values set in <i>C1-01</i> or <i>C1-03 [Acceleration Times]</i> to get the necessary torque. Increase the values set in <i>C2-01</i> to <i>C2-04 [S-Curve Characteristics]</i> to get the necessary torque. Replace the drive with a larger capacity model.
		The drive is trying to operate a specialized motor or a motor that is larger than the maximum applicable motor output of the drive.	<ul style="list-style-type: none"> Examine the motor nameplate, the motor, and the drive to make sure that the drive rated current is larger than the motor rated current. Replace the drive with a larger capacity model.
		A magnetic contactor was switched at the output.	Set the operation sequence to not turn ON or OFF the magnetic contactor while the drive is outputting voltage.
		The V/f pattern settings are incorrect.	<ul style="list-style-type: none"> Examine the ratios between the V/f pattern frequency and voltage. Decrease the voltage if it is too high compared to the frequency. Adjust <i>E1-04</i> to <i>E1-10 [V/f Pattern Parameters]</i>.
		The torque compensation gain is too large.	Decrease the value set in <i>C4-01 [Torque Compensation Gain]</i> to make sure that the motor does not stall.
		Electrical interference caused a problem.	Examine the control circuit lines, main circuit lines, and ground wiring, and decrease the effects of electrical interference.
		The gain during overexcitation operation is too large.	<ul style="list-style-type: none"> Find the time when the fault occurs. If the fault occurs at the same time as overexcitation operation, decrease the value set in <i>n3-13 [OverexcitationBraking (OEB) Gain]</i> and consider the motor flux saturation.
		The drive received a Run command while the motor was coasting.	<ul style="list-style-type: none"> Examine the sequence and input the Run command after the motor fully stops. Set <i>b3-01 = 1 [Speed Search at Start Selection = Enabled]</i> or set <i>H1-xx = 61, 62 [Speed Search from Fmax or Fref]</i> to input speed search commands from the MFDI terminals.
		The motor main circuit cable is too long.	Replace the drive with a larger capacity model.
		The relay or contactor on the soft-charge bypass relay is damaged.	<ul style="list-style-type: none"> Re-energize the drive. If the fault stays, replace the control board or the drive.
An overcurrent condition occurred during overexcitation deceleration.	<ul style="list-style-type: none"> Decrease the value set in <i>n3-13 [OverexcitationBraking (OEB) Gain]</i>. Decrease the value set in <i>n3-21 [HSB Current Suppression Level]</i>. 		
OD	Output Disconnect	The output circuit between the drive and the motor is open, and the drive output current is less than 5% of <i>E2-01 [Motor Rated Current (FLA)]</i> .	<ul style="list-style-type: none"> Close the disconnected output circuit between the drive and the motor. You can adjust <i>Y4-42 [Output Disconnect Detection Sel]</i> to disable this fault.
oFA00	Option Not Compatible with Port	The option card connected to connector CN5 is not compatible or it is not functioning correctly.	Remove the option PCB connected to CN5 on the bypass controller.
		The DIP switches on a JOHB-SMP3 Multi-Protocol Ethernet card are set incorrectly for your protocol.	Check the DIP switch settings for your protocol. Refer to the instructions packaged with the JOHB-SMP3 card for more information.

5 Troubleshooting

Code	Name	Causes	Possible Solutions
oFA01	Option Fault/Connection Error	The option card connected to connector CN5 is not compatible.	<ol style="list-style-type: none"> 1. De-energize the drive. 2. Refer to the option card manual and correctly connect the option card to the connector on the bypass controller.
oFA05	Option A/D Error	A fault occurred in the option card.	<ol style="list-style-type: none"> 1. De-energize the drive. 2. Make sure that the option card is correctly connected to the connector. 3. If the problem continues, replace the option card.
oFA06	Option Communication Error	A fault occurred in the option card.	<ol style="list-style-type: none"> 1. De-energize the drive. 2. Make sure that the option card is correctly connected to the connector. 3. If the problem continues, replace the option card.
oFA10	Option RAM Error	A fault occurred in the option card.	<ol style="list-style-type: none"> 1. De-energize the drive. 2. Make sure that the option card is correctly connected to the connector. 3. If the problem continues, replace the option card.
oFA11	Option Ope Mode Error	A fault occurred in the option card.	<ol style="list-style-type: none"> 1. De-energize the drive. 2. Make sure that the option card is correctly connected to the connector. 3. If the problem continues, replace the option card.
oFA12	Drive Receive CRC Error	A fault occurred in the option card.	<ol style="list-style-type: none"> 1. De-energize the drive. 2. Make sure that the option card is correctly connected to the connector. 3. If the problem continues, replace the option card.
oFA13	Drive Receive Frame Error	A fault occurred in the option card.	<ol style="list-style-type: none"> 1. De-energize the drive. 2. Make sure that the option card is correctly connected to the connector. 3. If the problem continues, replace the option card.
oFA14	Drive Receive Abort Error	A fault occurred in the option card.	<ol style="list-style-type: none"> 1. De-energize the drive. 2. Make sure that the option card is correctly connected to the connector. 3. If the problem continues, replace the option card.
oFA15	Option Receive CRC Error	A fault occurred in the option card.	<ol style="list-style-type: none"> 1. De-energize the drive. 2. Make sure that the option card is correctly connected to the connector. 3. If the problem continues, replace the option card.
oFA16	Option Receive Frame Error	A fault occurred in the option card.	<ol style="list-style-type: none"> 1. De-energize the drive. 2. Make sure that the option card is correctly connected to the connector. 3. If the problem continues, replace the option card.
oFA17	Option Receive Abort Error	A fault occurred in the option card.	<ol style="list-style-type: none"> 1. De-energize the drive. 2. Make sure that the option card is correctly connected to the connector. 3. If the problem continues, replace the option card.
oFA30	COM ID Error	A fault occurred in the option card.	<ol style="list-style-type: none"> 1. De-energize the drive. 2. Make sure that the option card is correctly connected to the connector. 3. If the problem continues, replace the option card.
oFA31	Type Code Error	A fault occurred in the option card.	<ol style="list-style-type: none"> 1. De-energize the drive. 2. Make sure that the option card is correctly connected to the connector. 3. If the problem continues, replace the option card.
oFA32	SUM Check Error	A fault occurred in the option card.	<ol style="list-style-type: none"> 1. De-energize the drive. 2. Make sure that the option card is correctly connected to the connector. 3. If the problem continues, replace the option card.
oFA33	Option Receive Time Over	A fault occurred in the option card.	<ol style="list-style-type: none"> 1. De-energize the drive. 2. Make sure that the option card is correctly connected to the connector. 3. If the problem continues, replace the option card.
oFA34	Memobus Time Over	A fault occurred in the option card.	<ol style="list-style-type: none"> 1. De-energize the drive. 2. Make sure that the option card is correctly connected to the connector. 3. If the problem continues, replace the option card.

Code	Name	Causes	Possible Solutions
oFA35	Drive Receive Time Over 1	A fault occurred in the option card.	<ol style="list-style-type: none"> 1. De-energize the drive. 2. Make sure that the option card is correctly connected to the connector. 3. If the problem continues, replace the option card.
oFA36	CI Check Error	A fault occurred in the option card.	<ol style="list-style-type: none"> 1. De-energize the drive. 2. Make sure that the option card is correctly connected to the connector. 3. If the problem continues, replace the option card.
oFA37	Drive Receive Time Over 2	A fault occurred in the option card.	<ol style="list-style-type: none"> 1. De-energize the drive. 2. Make sure that the option card is correctly connected to the connector. 3. If the problem continues, replace the option card.
oFA38	Control Reference Error	A fault occurred in the option card.	<ol style="list-style-type: none"> 1. De-energize the drive. 2. Make sure that the option card is correctly connected to the connector. 3. If the problem continues, replace the option card.
oFA39	Drive Receive Time Over 3	A fault occurred in the option card.	<ol style="list-style-type: none"> 1. De-energize the drive. 2. Make sure that the option card is correctly connected to the connector. 3. If the problem continues, replace the option card.
oFA40	CtrlResSel 1Err	A fault occurred in the option card.	<ol style="list-style-type: none"> 1. De-energize the drive. 2. Make sure that the option card is correctly connected to the connector. 3. If the problem continues, replace the option card.
oFA41	Drive Receive Time Over 4	A fault occurred in the option card.	<ol style="list-style-type: none"> 1. De-energize the drive. 2. Make sure that the option card is correctly connected to the connector. 3. If the problem continues, replace the option card.
oFA42	CtrlResSel 2Err	A fault occurred in the option card.	<ol style="list-style-type: none"> 1. De-energize the drive. 2. Make sure that the option card is correctly connected to the connector. 3. If the problem continues, replace the option card.
oFA43	Drive Receive Time Over 5	A fault occurred in the option card.	<ol style="list-style-type: none"> 1. De-energize the drive. 2. Make sure that the option card is correctly connected to the connector. 3. If the problem continues, replace the option card.
oH	Heatsink Overheat	The ambient temperature is high and the heatsink temperature of the drive is more than the value set in <i>L8-02 [Overheat Alarm Level]</i> .	<ul style="list-style-type: none"> • Measure the ambient temperature. • Increase the airflow in the control panel. • Install a cooling device (cooling fan or air conditioner) to lower the ambient temperature. • Remove objects near the drive that are producing too much heat.
		The load is too heavy.	<ul style="list-style-type: none"> • Measure the output current. • Decrease the load. • Decrease the value set in <i>C6-02 [Carrier Frequency Selection]</i>.
		The internal cooling fan of the drive stopped.	<ol style="list-style-type: none"> 1. Use the procedures in this manual to replace the cooling fan. 2. Set <i>o4-03 = 0 [Fan Operation Time Setting = 0 h]</i>.
oH1	Heatsink Overheat	The ambient temperature is high and the heatsink temperature of the drive is more than the <i>oH1</i> detection level.	<ul style="list-style-type: none"> • Measure the ambient temperature. • Increase the airflow in the control panel. • Install a cooling device (cooling fan or air conditioner) to lower the ambient temperature. • Remove objects near the drive that are producing too much heat.
		The load is too heavy.	<ul style="list-style-type: none"> • Measure the output current. • Decrease the load. • Decrease the value set in <i>C6-02 [Carrier Frequency Selection]</i>.
oH3	Motor Overheat (PTC Input)	The thermistor wiring that detects motor temperature is defective.	Correct wiring errors.
		A fault occurred on the machine. Example: The machine is locked.	Examine the machine and remove the cause of the fault

5 Troubleshooting

Code	Name	Causes	Possible Solutions
		The motor has overheated.	<ul style="list-style-type: none"> Check the load level, acceleration/deceleration time, and motor start/stop frequency (cycle time). Decrease the load. Increase the values set in <i>C1-01 to C1-04 [Acceleration/Deceleration Times]</i>. Set <i>E2-01 [Motor Rated Current (FLA)]</i> correctly to the value specified by the motor nameplate. Make sure that the motor cooling system is operating correctly, and repair or replace it if it is damaged. Adjust <i>E1-04 to E1-10 [V/f Pattern Parameters]</i>. Decrease the values set in <i>E1-08 [Mid Point A Voltage]</i> and <i>E1-10 [Minimum Output Voltage]</i>. <p>Note: If the values set in <i>E1-08</i> and <i>E1-10</i> are too low, the overload tolerance will decrease at low speeds.</p>
oH4	Motor Overheat Fault (PTC Input)	The motor has overheated.	<ul style="list-style-type: none"> Check the load level, acceleration/deceleration time, and motor start/stop frequency (cycle time). Decrease the load. Increase the values set in <i>C1-01 to C1-04 [Acceleration/Deceleration Times]</i>. Set <i>E2-01 [Motor Rated Current (FLA)]</i> correctly to the value specified by the motor nameplate. Make sure that the motor cooling system is operating correctly, and repair or replace it if it is damaged. Adjust <i>E1-04 to E1-10 [V/f Pattern Parameters]</i>. Decrease the values set in <i>E1-08 [Mid Point A Voltage]</i> and <i>E1-10 [Minimum Output Voltage]</i>. <p>Note: If <i>E1-08</i> and <i>E1-10</i> are set too low, the overload tolerance will decrease at low speeds.</p>
oL1	Motor Overload	The load is too heavy.	<p>Decrease the load.</p> <p>Note: Reset <i>oL1</i> when <i>U4-16 [Motor oL1 Level] < 100</i>.</p>
		The acceleration/deceleration times or cycle times are too short.	<ul style="list-style-type: none"> Examine the acceleration/deceleration times and the motor start/stop frequencies (cycle times). Increase the values set in <i>C1-01 to C1-04 [Acceleration/Deceleration Times]</i>.
		Overload occurred while running at low speed.	<ul style="list-style-type: none"> Decrease the load when running at low speed. Increase the motor speed. If the motor is run frequently at low speeds, replace the motor with a larger motor or use a drive-dedicated motor. <p>Note: For general-purpose motors, overload can occur while running at low speed when operating at below the rated current.</p>
		The V/f pattern does not fit the motor qualities.	<ul style="list-style-type: none"> Examine the ratios between the V/f pattern frequency and voltage. Decrease the voltage if it is too high compared to the frequency. Adjust <i>E1-04 to E1-10 [V/f Pattern Parameters]</i>. Decrease the values set in <i>E1-08 [Mid Point A Voltage]</i> and <i>E1-10 [Minimum Output Voltage]</i>. <p>Note: If the values set in <i>E1-08</i> and <i>E1-10</i> are too low, the overload tolerance will decrease at low speeds.</p>
		<i>E1-06 [Base Frequency]</i> is set incorrectly.	Set <i>E1-06</i> to the rated frequency shown on the motor nameplate.
		One drive is operating more than one motor.	Set <i>L1-01 = 0 [Motor Overload (oL1) Protection = Disabled]</i> , connect thermal overload relay to each motor to prevent damage to the motor.
		The electronic thermal protector qualities and the motor overload properties do not align.	Connect a thermal overload relay to the motor.
		The electronic thermal protector is operating at an incorrect level.	Set <i>E2-01 [Motor Rated Current (FLA)]</i> correctly to the value specified by the motor nameplate.
		There is increased motor loss from overexcitation operation.	<ul style="list-style-type: none"> Lower the value set in <i>n3-13 [OverexcitationBraking (OEB) Gain]</i>. Set <i>L3-04 ≠ 4 [Stall Prevention during Decel ≠ Overexcitation/High Flux]</i>. Set <i>n3-23 = 0 [Overexcitation Braking Operation = Disabled]</i>.
The speed search-related parameters are set incorrectly.	<ul style="list-style-type: none"> Examine the settings for all speed search related parameters. Adjust <i>b3-03 [Speed Search Deceleration Time]</i>. Set <i>b3-24 = 1 [Speed Search Method Selection = Speed Estimation]</i> after Auto-Tuning. 		

Code	Name	Causes	Possible Solutions
		Phase loss in the input power supply is causing the output current to change.	Make sure that there is no phase loss, and repair problems.
		Overload occurred during overexcitation deceleration.	<ul style="list-style-type: none"> Decrease the value set in <i>n3-13</i> [<i>OverexcitationBraking (OEB) Gain</i>]. Decrease the value set in <i>n3-21</i> [<i>HSB Current Suppression Level</i>].
oL2	Drive Overload	The load is too large.	Decrease the load.
		The acceleration/deceleration times or cycle times are too short.	<ul style="list-style-type: none"> Examine the acceleration/deceleration times and the motor start/stop frequencies (cycle times). Increase the values set in <i>C1-01</i> to <i>C1-04</i> [<i>Acceleration/Deceleration Times</i>].
		The V/f pattern does not fit the motor qualities.	<ul style="list-style-type: none"> Examine the ratios between the V/f pattern frequency and voltage. Decrease the voltage if it is too high compared to the frequency. Adjust <i>E1-04</i> to <i>E1-10</i> [<i>V/f Pattern Parameters</i>]. Decrease the values set in <i>E1-08</i> [<i>Mid Point A Voltage</i>] and <i>E1-10</i> [<i>Minimum Output Voltage</i>]. <p>Note: If the values set in <i>E1-08</i> and <i>E1-10</i> are too low, the overload tolerance will decrease at low speeds.</p>
		The drive capacity is too small.	Replace the drive with a larger capacity model.
		Overload occurred while running at low speed.	<ul style="list-style-type: none"> Decrease the load when running at low speed. Replace the drive with a larger capacity model. Decrease the value set in <i>C6-02</i> [<i>Carrier Frequency Selection</i>].
		The torque compensation gain is too large.	Decrease the value set in <i>C4-01</i> [<i>Torque Compensation Gain</i>] to make sure that the motor does not stall.
		The speed search-related parameters are set incorrectly.	<ul style="list-style-type: none"> Examine the settings for all speed search-related parameters. Adjust <i>b3-03</i> [<i>Speed Search Deceleration Time</i>]. Set <i>b3-24</i> = 1 [<i>Speed Search Method Selection = Speed Estimation</i>] after Auto-Tuning.
		Phase loss in the input power supply is causing the output current to change.	<ul style="list-style-type: none"> Correct errors with the wiring for main circuit drive input power. Make sure that there is no phase loss, and repair problems.
		Overload occurred during overexcitation deceleration.	<ul style="list-style-type: none"> Decrease the value set in <i>n3-13</i> [<i>OverexcitationBraking (OEB) Gain</i>]. Decrease the value set in <i>n3-21</i> [<i>HSB Current Suppression Level</i>].
oL3	Overtorque Detection 1	A fault occurred on the machine. Example: The machine is locked.	Examine the machine and remove the cause of the fault.
		The parameters are incorrect for the load.	Adjust <i>L6-02</i> [<i>Torque Detection Level 1</i>] and <i>L6-03</i> [<i>Torque Detection Time 1</i>] settings.
oL4	Overtorque Detection 2	A fault occurred on the machine. Example: The machine is locked.	Examine the machine and remove the cause of the fault.
		The parameters are incorrect for the load.	Adjust <i>L6-05</i> [<i>Torque Detection Level 2</i>] and <i>L6-06</i> [<i>Torque Detection Time 2</i>] settings.
oL7	High Slip Braking Overload	The load inertia is too large.	Decrease deceleration times in <i>C1-02</i> and <i>C1-04</i> [<i>Deceleration Times</i>] for applications that do not use High Slip Braking.
	An external force on the load side rotated the motor.		
	Something is preventing deceleration on the load side.		
		The value set in <i>n3-04</i> [<i>HSB Overload Time</i>] is too small.	<ul style="list-style-type: none"> Increase the value set in <i>n3-04</i>. Connect a thermal overload relay to the motor, and set <i>n3-04</i> = 1200 s (maximum value).
oPr	Keypad Connection Fault	The keypad is not securely connected to the connector on the bypass controller.	Examine the connection between the keypad and the bypass controller.
		The connection cable between the bypass controller and the keypad is disconnected.	<ul style="list-style-type: none"> Remove the keypad and connect it again. If the cable is damaged, replace it.
ov	Overvoltage	Deceleration time is too short and regenerative energy is flowing from the motor into the drive.	<ul style="list-style-type: none"> Set <i>L3-04</i> = 1 [<i>Stall Prevention during Decel = General Purpose</i>]. Increase the values set in <i>C1-02</i> or <i>C1-04</i> [<i>Deceleration Times</i>]. Do Deceleration Rate Auto-Tuning.

5 Troubleshooting

Code	Name	Causes	Possible Solutions
		The acceleration time is too short.	<ul style="list-style-type: none"> Make sure that sudden drive acceleration does not cause the fault. Increase the values set in C1-01 or C1-03 [Acceleration Times]. Increase the value set in C2-02 [S-Curve Time @ End of Accel]. Set L3-11 = 1 [Overvoltage Suppression Select = Enabled].
		The drive output cable or motor is shorted to ground (the current short to ground is charging the main circuit capacitor of the drive through the power supply).	<ol style="list-style-type: none"> Examine the motor main circuit cable, terminals, and motor terminal box, and then remove ground faults. Re-energize the drive.
		If the drive detects <i>ov</i> in these conditions, the speed search-related parameters are incorrect: <ul style="list-style-type: none"> During speed search During momentary power loss recovery When the drive starts again automatically When you do rotational Auto-Tuning 	<ul style="list-style-type: none"> Examine the settings for all speed search related parameters. Set b3-19 ≠ 0 [Speed Search Restart Attempts ≠ 0 times]. Adjust b3-03 [Speed Search Deceleration Time] setting. Do Stationary Auto-Tuning for Line-to-Line Resistance and then set b3-24 = 1 [Speed Search Method Selection = Speed Estimation]. Increase the value set in L2-04 [Powerloss V/f Recovery Ramp Time].
		The power supply voltage is too high.	Decrease the power supply voltage to align with the drive rated voltage.
		Electrical interference caused a drive malfunction.	<ul style="list-style-type: none"> Examine the control circuit lines, main circuit lines, and ground wiring, and decrease the effects of electrical interference. Make sure that a magnetic contactor is not the source of the electrical interference, then use a Surge Protective Device if necessary.
		The load inertia is set incorrectly.	<ul style="list-style-type: none"> Examine the load inertia settings with overvoltage suppression or stall prevention during deceleration. Adjust L3-25 [Load Inertia Ratio] to align with the qualities of the machine.
		There is motor hunting.	Adjust n1-02 [Hunting Prevention Gain Setting] settings.
ov2	DC Bus Overvoltage 2	The wiring is too long and DC bus voltage is too large.	<ul style="list-style-type: none"> Shorten the shielded motor cable. Decrease the carrier frequency. If the power supply has a neutral ground, switch on the internal EMC filter.
PE1, PE2	PLC Faults	The communication option detected a fault.	Refer to the manual for the communication option card.
PF	Input Phase Loss	There is a phase loss in the drive input power.	Correct errors with the wiring for main circuit drive input power.
		There is loose wiring in the drive input power terminals.	Tighten the terminal screws to the correct tightening torque.
		The drive input power voltage is changing too much.	<ul style="list-style-type: none"> Examine the input power for problems. Make the drive input power stable. If the input power supply is good, examine the magnetic contactor on the main circuit side for problems.
		There is unsatisfactory balance between voltage phases.	<ul style="list-style-type: none"> Examine the input power for problems. Make the drive input power stable. Set L8-05 = 0 [Input Phase Loss Protection Sel = Disabled].
		The main circuit capacitors have become unserviceable.	<ul style="list-style-type: none"> Examine the capacitor maintenance time in monitor U4-05 [Capacitor Maintenance]. If U4-05 is more than 90%, replace the control board or the drive. For information about replacing the control board, contact Yaskawa or your nearest sales representative. If drive input power is correct and the fault stays, replace the control board or the drive. For information about replacing the control board, contact Yaskawa or your nearest sales representative.
PSE	JOHB-SMP3 Protocol Set Error	<ul style="list-style-type: none"> The DIP switches on the JOHB-SMP3 Multi-Protocol Ethernet Card are at factory default settings. The DIP switches on the JOHB-SMP3 are not set to a valid protocol. 	<p>Remove power from the drive, wait for the charge light to go out, then set the DIP switches on the JOHB-SMP3 to the desired protocol.</p> <p>Note: Refer to the instructions packaged with the JOHB-SMP3 for more information about DIP switch settings.</p>
SC	Short Circuit/IGBT Failure	Overheating caused damage to the motor or the motor insulation is not satisfactory.	Measure the motor insulation resistance, and replace the motor if there is electrical conduction or unserviceable insulation.
		The motor main circuit cable is contacting ground to make a short circuit.	<ul style="list-style-type: none"> Examine the motor main circuit cable for damage, and repair short circuits. Measure the resistance between the motor main circuit cable and the ground terminal. If there is electrical conduction, replace the cable.

Code	Name	Causes	Possible Solutions
		A short circuit or ground fault on the drive output side caused damage to the output transistor of the drive.	<ul style="list-style-type: none"> Make sure that there is not a short circuit in terminal B1 and terminals U/T1, V/T2, and W/T3. Make sure that there is not a short circuit in terminals - and terminals U/T1, V/T2, and W/T3. If there is a short circuit, contact Yaskawa or your nearest sales representative.
SCF	Safety Circuit Fault	The safety circuit is broken.	Replace the control board or the drive. For information about replacing the control board, contact Yaskawa or your nearest sales representative.
SEr	Speed Search Retries Exceeded	The speed search-related parameters are set incorrectly.	<ul style="list-style-type: none"> Decrease <i>b3-10 [Speed Estimation Detection Gain]</i>. Increase <i>b3-17 [Speed Est Retry Current Level]</i>. Increase <i>b3-18 [Speed Est Retry Detection Time]</i>. Do Auto-Tuning again.
		The motor is coasting in the opposite direction of the Run command.	Set <i>b3-14 = 1 [Bi-directional Speed Search = Enabled]</i> .
TiM	Keypad Time Not Set	There is a battery in the keypad, but the date and time are not set.	Use the keypad to set the date and time.
UL3	Undertorque Detection 1	A fault occurred on the machine. Example: There is a broken pulley belt.	Examine the machine and remove the cause of the fault.
		The parameters are incorrect for the load.	Adjust <i>L6-02 [Torque Detection Level 1]</i> and <i>L6-03 [Torque Detection Time 1]</i> settings.
UL4	Undertorque Detection 2	A fault occurred on the machine. Example: There is a broken pulley belt.	Examine the machine and remove the cause of the fault.
		The parameters are incorrect for the load.	Adjust <i>L6-05 [Torque Detection Level 2]</i> and <i>L6-06 [Torque Detection Time 2]</i> settings.
UL6	Underload or Belt Break Detected	The output current decreased less than the motor underload curve set in <i>L6-14 [Motor Underload Level @ Min Freq]</i> for longer than the time set in <i>L6-03 [Torque Detection Time 1]</i> .	Adjust the <i>L6-14</i> setting to set the output current to stay the level more than the motor underload curve during usual operations.
Uv1	DC Bus Undervoltage	There is a phase loss in the drive input power.	Correct errors with the wiring for main circuit drive input power.
		There is loose wiring in the drive input power terminals.	Tighten the terminal screws to the correct tightening torque.
		The drive input power voltage is changing too much.	<ul style="list-style-type: none"> Examine the input power for problems. Make the drive input power stable. If the input power supply is good, examine the magnetic contactor on the main circuit side for problems.
		There was a loss of power.	Use a better power supply.
		The main circuit capacitors have become unserviceable.	Examine the capacitor maintenance time in monitor <i>U4-05 [Capacitor Maintenance]</i> . If <i>U4-05</i> is more than 90%, replace the control board or the drive. For information about replacing the control board, contact Yaskawa or your nearest sales representative.
		The relay or contactor on the soft-charge bypass relay is damaged.	<i>U4-06 [PreChargeRelayMainte]</i> shows the performance life of the soft-charge bypass relay. If <i>U4-06</i> is more than 90%, replace the board or the drive. For information about replacing the board, contact Yaskawa or your nearest sales representative.
Uv2	Control Power Undervoltage	The value set in <i>L2-02 [Power Loss Ride Through Time]</i> increased and the momentary power loss recovery unit is not connected to the drive.	Connect the momentary power loss recovery unit to the drive.
		There was a problem with the drive hardware.	<ul style="list-style-type: none"> Re-energize the drive. If the fault stays, replace the control board or the drive. For information about replacing the control board, contact Yaskawa or your nearest sales representative.
Uv3	Soft Charge Answerback Fault	The relay or contactor on the soft-charge bypass relay is damaged.	<ul style="list-style-type: none"> Re-energize the drive. If the fault stays, replace the control board or the drive. Check monitor <i>U4-06 [PreChargeRelayMainte]</i>, which shows the performance life of the soft-charge bypass relay. If <i>U4-06</i> is more than 90%, replace the board or the drive. For information about replacing the board, contact Yaskawa or your nearest sales representative.
VLTS	Thermostat Fault	The digital input from the terminal set for <i>Thermostat Fault [H1-xx = 88]</i> is active.	Examine the wiring or wait for the motor to cool.

◆ Minor Faults/Alarms

This section gives information about the causes and possible solutions when a minor fault or alarm occurs. Use the information in this table to remove the cause of the minor fault or alarm.

5 Troubleshooting

Code	Name	Causes	Possible Solutions
AFBL	Analog Fbk Lost, Switched to Net	The analog input source is defective or broken.	Make sure that you install the PID Feedback source and it operates correctly.
		The parameter setting is $H3-xx \neq B$ [<i>MFAI Function Selection \neq PID Feedback</i>].	Set $H3-xx = B$ to use the analog input source for PID Feedback.
AuDis	Low PI Aux Fdbk Drive Disabled	<ul style="list-style-type: none"> PI Auxiliary Feedback is less than the $YF-06$ [<i>PI Aux Control Wake-up Level</i>] setting, and the drive is stopped or running as a Lag drive. 	<ul style="list-style-type: none"> Make sure that the $YF-06$ setting is correct. Wait for the PI Auxiliary Feedback to recover.
AL02	Interlock Open	The digital input set to interlock is open	Make sure that the damper is functioning correctly. The damper could be opening and the switch could be open.
AL03	Emergency Override Bypass	The digital input terminal set to $H2-0x = 25$ [<i>Digital input function selection = Emergency Override Bypass</i>] activated.	When the emergency condition is gone, deactivate the digital input set to <i>Emergency Override Bypass</i> .
AL09	Restart Delay Active	The restart delay is active and the drive received a Run command.	<ul style="list-style-type: none"> This is not an alarm. It is information to show that the drive is not running. When you remove the Run command to the drive, the $AL09$ alarm will go away. Parameters $Z1-60$ [<i>Blackout Operation Select</i>] and $Z1-61$ [<i>Power Loss Restart Delay Time</i>] set restart delay.
AL13	Loss of Load Detected	The motor is disconnected from the load.	Replace the belt or coupling between the motor and the load. If the bypass detected this alarm incorrectly, make sure that parameters $Z1-31$ to $Z1-36$ are correct for your application.
AL16	Input Phase Rotation	The phase rotation is incorrect while $Z1-52 = 1$ in Bypass Mode.	Make sure that the sequence (phase rotation) of the input wiring to the bypass package is correct.
AL17	Remote Xfer disabled in Reverse	The drive is running in reverse and it received a Remote Transfer command.	This is not an alarm. It is information to show that the bypass cannot remote transfer when the drive is running in reverse.
AL18	Auto Xfer disabled in Reverse	When auto transfer is enabled, the drive detects a fault and it cannot transfer while it is running in reverse.	This is not an alarm. It is information to show that the drive cannot auto transfer when reverse run is active.
AuFbl	PI Aux Fdbk Lost Switched to Net	The analog input source is defective or broken.	Make sure that you install the Auxiliary PI Feedback source and it operates correctly.
AUXFB	PI Aux Feedback Level Loss	The analog input from the terminal set to $H3-xx = 27$ [<i>MFAI Function Selection = PI Auxiliary Control Feedback Level</i>] is more than 21 mA or less than 3 mA for longer than 1 s.	Repair transducer or wiring.
bAT	Keypad Battery Low Voltage	The keypad battery voltage is low.	Replace the keypad battery.
bb	Baseblock	An external baseblock command was entered through one of the drive MFDI terminals Sx , and the drive output stopped as shown by an external baseblock command.	Examine the external sequence and timing of the baseblock command input.
bCE	Bluetooth Communication Error	The smartphone or tablet with DriveWizard Mobile is too far from the keypad.	Move to 10 m (32.8 ft) or less from the keypad. Note: bCE can occur when the smartphone or tablet is 10 m (32.8 ft) or nearer to the keypad for different smartphone and tablet specifications.
		Radio waves from a different device are causing interference with communications between the smartphone or tablet and keypad.	Make sure that no device around the keypad uses the same radio bandwidth (2400 MHz to 2480 MHz), and prevent radio interference.
BuDif	Main Fdbk Lost, Using Diff Fdbk	Parameter $Y4-41 = 1$ [<i>Diff Lvl Src Fdbk Backup Select = Enabled</i>] and the drive detected a wire-break on the analog input terminal set for <i>PID Feedback</i> [$H3-xx = B$].	Examine the connection of the Main PID Feedback Transducer.
		Main PID Feedback Transducer is broken.	Replace Main PID Feedback Transducer.
Bu-Fb	Main Fdbk Lost Using Backup Fdbk	The drive detected wire-break on the analog input terminal set to $H3-xx = B$ [<i>MFAI Function Selection = PID Feedback</i>].	Examine the connection of the Main PID Feedback Transducer.
		Main PID Feedback Transducer is broken.	Replace Main PID Feedback Transducer.
BuFbl	Backup Fdbk Lost Chk/Repl Xducer	The drive detected wire-break on the analog input terminal set for <i>PID Feedback Backup</i> [$H3-xx = 24$].	Examine the connection of the Differential PID Feedback transducer.
		Backup PID Feedback Transducer is broken.	Replace Backup PID Feedback Transducer.
		Parameter $Y4-41 = 1$ [<i>Diff Lvl Src Fdbk Backup Select = Enabled</i>] and the drive detected a wire-break on the analog input terminal set for <i>Differential Level Source</i> [$H3-xx = 2D$].	Examine the connection of the Differential PID Feedback transducer.
		Parameter $Y4-41 = 1$ and the Differential PID Feedback Transducer is broken.	<ul style="list-style-type: none"> Replace the Differential PID Feedback Transducer. Set $Y4-41 = 0$ [<i>Disabled</i>].
bUS	Option Communication Error	The communications cable wiring is incorrect.	Correct wiring errors.

Code	Name	Causes	Possible Solutions
		There is a short-circuit in the communications cable or the communications cable is not connected.	<ul style="list-style-type: none"> Repair short circuits and connect cables. Replace the defective communications cable.
		Electrical interference caused a communication data error.	<ul style="list-style-type: none"> Examine the control circuit lines, main circuit lines, and ground wiring, and decrease the effects of electrical interference. Make sure that a magnetic contactor is not the source of the electrical interference, then use a Surge Protective Device if necessary. Use only the recommended cables or other shielded line. Ground the shield on the controller side or the drive input power side. Separate the communication wiring from drive power lines, and install a noise filter to the input side of the power supply for communication. Decrease the effects of electrical interference from the controller.
		The option card is incorrectly installed to the bypass controller.	Correctly install the option card to the bypass controller.
		The option card is damaged.	If the alarm continues and the wiring is correct, replace the option card.
bUSy	Busy	You set the bypass controller to use serial communications to change parameters, but you used the keypad to change parameters.	Use serial communications to enter the enter command, then use the keypad to change the parameter.
		You tried to change a parameter while the bypass controller was changing a setting.	Wait until the process is complete.
CALL	Serial Comm Transmission Error	The communications cable wiring is incorrect.	Correct wiring errors.
		There is a short circuit in the communications cable or the communications cable is not connected.	<ul style="list-style-type: none"> Repair the short-circuited or disconnected portion of the cable. Replace the defective communications cable.
		A programming error occurred on the controller side.	Examine communications at start-up and correct programming errors.
		There is damage to the communications circuitry.	<ul style="list-style-type: none"> Do a self-diagnostics check. If the problem continues, replace the control board or the drive. Contact Yaskawa or your nearest sales representative to replace the control board.
		The termination resistor setting for RS-485-based communications is incorrect.	On the last drive of an RS-485-based network, set DIP switch S2 to the ON position to enable the termination resistor.
CE	Serial Communication Error	The communications cable wiring is incorrect.	Correct wiring errors.
		There is a short circuit in the communications cable or the communications cable is not connected.	<ul style="list-style-type: none"> Repair short circuits and connect cables. Replace the defective communications cable.
		Electrical interference caused a communication data error.	<ul style="list-style-type: none"> Examine the control circuit lines, main circuit lines, and ground wiring, and decrease the effects of electrical interference. Make sure that a magnetic contactor is not the source of the electrical interference, then use a Surge Protective Device if necessary. Use only the recommended cables or other shielded line. Ground the shield on the controller side or the drive input power side. Separate the communication wiring from drive power lines, and install a noise filter to the input side of the power supply for communication. Decrease the effects of electrical interference from the controller.
		The communication protocol is not compatible.	<ul style="list-style-type: none"> Examine the values set in <i>H5-xx</i>. Examine the settings on the controller side and correct the difference in communication conditions.
		The value set in <i>H5-09 [CE Detection Time]</i> is too small for the communications cycle.	<ul style="list-style-type: none"> Change the controller software settings. Increase the value set in <i>H5-09</i>.
		The controller software or hardware is causing a communication problem.	Examine the controller and remove the cause of the problem.
CE	Run at H5-34 (CE Go-To-Freq)	The communications cable wiring is incorrect.	Correct wiring errors.
		There is a short circuit in the communications cable or the communications cable is not connected.	<ul style="list-style-type: none"> Repair short circuits and connect cables. Replace the defective communications cable.

5 Troubleshooting

Code	Name	Causes	Possible Solutions
		Electrical interference caused a communication data error.	<ul style="list-style-type: none"> Examine the control circuit lines, main circuit lines, and ground wiring, and decrease the effects of electrical interference. Make sure that a magnetic contactor is not the source of the electrical interference, then use a Surge Protective Device if necessary. Use only recommended shielded line. Ground the shield on the controller side or on the drive input power side. Separate the communication wiring from drive power lines, and install a noise filter to the input side of the power supply for communication. Decrease the effects of electrical interference from the controller.
		The communication protocol is not compatible.	<ul style="list-style-type: none"> Examine the values set in <i>H5-xx</i>. Examine the settings on the controller side and correct the difference in communication conditions.
		The value set in <i>H5-09 [CE Detection Time]</i> is too small for the communications cycle.	<ul style="list-style-type: none"> Make sure that the settings are compatible. Change the software settings in the PLC. Increase the value set in <i>H5-09</i>.
		The controller software or hardware is causing a communication problem.	Examine the controller and remove the cause of the problem.
CrST	Cannot Reset	The drive received a fault reset command when a Run command was active.	Turn off the Run command or switch into OFF mode, then reset the fault.
CyPo	Cycle Power to Accept Changes	Although <i>F6-15 = 1 [Comm. Option Parameters Reload = Reload Now]</i> , the drive does not update the communication option parameters.	De-energize then re-energize the bypass to activate the new option communication parameters.
DIFF	Differential Feedback Exceeded	The difference between the PID Feedback and <i>Differential Level Source [H3-xx = 2D]</i> is more than the level set in <i>Y4-18 [Pre-Charge Loss of Prime Level 2]</i> for the time set in <i>Y4-19 [Differential Lvl Detection Time]</i> .	<ul style="list-style-type: none"> Replace the feedback transducer or transducers. Set <i>Y4-18</i> and <i>Y4-19</i> correctly.
dnE	Drive Disabled	A terminal set for <i>H1-xx = 6A [MFDI Function Selection = Drive Enable]</i> deactivated.	Examine the operation sequence.
EF	FWD/REV Run Command Input Error	The drive received a forward command and a reverse command at the same time for longer than 0.5 s.	Examine the forward and reverse command sequence and correct the problem.
EF0	Option Card External Fault	The communication option card received an external fault from the controller.	<ol style="list-style-type: none"> Find the device that caused the external fault and remove the cause. Clear the external fault input from the controller.
		Programming error occurred on the controller side.	Examine the operation of the controller program.
EF1	External Fault (Terminal S1)	MFDI terminal S1 caused an external fault through an external device.	<ol style="list-style-type: none"> Find the device that caused the external fault and remove the cause. Clear the external fault input in the MFDI.
		The wiring is incorrect.	Correctly connect the signal line to MFDI terminal S1.
		<i>External Fault [H1-01 = 2C to 2F]</i> is set to MFDI terminal S1, but the terminal is not in use.	Correctly set the MFDI.
EF2	External Fault (Terminal S2)	MFDI terminal S2 caused an external fault through an external device.	<ol style="list-style-type: none"> Find the device that caused the external fault and remove the cause. Clear the external fault input in the MFDI.
		The wiring is incorrect.	Correctly connect the signal line to MFDI terminal S2.
		<i>External Fault [H1-02 = 2C to 2F]</i> is set to MFDI terminal S2, but the terminal is not in use.	Correctly set the MFDI.
EF3	External Fault (Terminal S3)	MFDI terminal S3 caused an external fault through an external device.	<ol style="list-style-type: none"> Find the device that caused the external fault and remove the cause. Clear the external fault input in the MFDI.
		The wiring is incorrect.	Correctly connect the signal line to MFDI terminal S3.
		<i>External Fault [H1-03 = 2C to 2F]</i> is set to MFDI terminal S3, but the terminal is not in use.	Correctly set the MFDI.
EF4	External Fault (Terminal S4)	MFDI terminal S4 caused an external fault through an external device.	<ol style="list-style-type: none"> Find the device that caused the external fault and remove the cause. Clear the external fault input in the MFDI.
		The wiring is incorrect.	Correctly connect the signal line to MFDI terminal S4.
		<i>External Fault [H1-04 = 2C to 2F]</i> is set to MFDI terminal S4, but the terminal is not in use.	Correctly set the MFDI.
EF5	External Fault (Terminal S5)	MFDI terminal S5 caused an external fault through an external device.	<ol style="list-style-type: none"> Find the device that caused the external fault and remove the cause. Clear the external fault input in the MFDI.

Code	Name	Causes	Possible Solutions
		The wiring is incorrect.	Correctly connect the signal line to MFDI terminal S5.
		<i>External Fault [H1-05 = 2C to 2F]</i> is set to MFDI terminal S5, but the terminal is not in use.	Correctly set the MFDI.
EF6	External Fault (Terminal S6)	MFDI terminal S6 caused an external fault through an external device.	<ol style="list-style-type: none"> Find the device that caused the external fault and remove the cause. Clear the external fault input in the MFDI.
		The wiring is incorrect.	Correctly connect the signal line to MFDI terminal S6.
		<i>External Fault [H1-06 = 2C to 2F]</i> is set to MFDI terminal S6, but the terminal is not in use.	Correctly set the MFDI.
EF7	External Fault (Terminal S7)	MFDI terminal S7 caused an external fault through an external device.	<ol style="list-style-type: none"> Find the device that caused the external fault and remove the cause. Clear the external fault input in the MFDI.
		The wiring is incorrect.	Correctly connect the signal line to MFDI terminal S7.
		<i>External Fault [H1-07 = 2C to 2F]</i> is set to MFDI terminal S7, but the terminal is not in use.	Correctly set the MFDI.
EF8	External Fault (Terminal S8)	MFDI terminal S8 caused an external fault through an external device.	<ol style="list-style-type: none"> Find the device that caused the external fault and remove the cause. Clear the external fault input in the MFDI.
		The wiring is incorrect.	Correctly connect the signal line to MFDI terminal S8.
		<i>External Fault [H1-08 = 2C to 2F]</i> is set to MFDI terminal S8, but the terminal is not in use.	Correctly set the MFDI.
EOF	Emergency Override FWD	The digital input terminal set to <i>H1-xx = AF [MFDI Function Selection = Emergency Override FWD]</i> activated.	When the emergency condition is gone, deactivate the digital input set to <i>Emergency Override FWD</i> .
EOR	Emergency Override REV	The digital input terminal set to <i>H1-xx = B0 [MFDI Function Selection = Emergency Override REV]</i> activated.	When the emergency condition is gone, deactivate the digital input set to <i>Emergency Override REV</i> .
EP24v	External Power 24V Supply	The voltage of the main circuit power supply decreased, and the 24 V power supply is supplying power to the drive.	<ul style="list-style-type: none"> Examine the main circuit power supply. Turn ON the main circuit power supply to run the drive.
FDBKL	Feedback Loss Wire Break	<p>The analog input from the terminal set to <i>H3-xx = B [MFAI Function Selection = PID Feedback]</i> is more than 21 mA or less than 3 mA for longer than 1 s in these conditions:</p> <ul style="list-style-type: none"> <i>b5-82 = 1 [Feedback Loss 4 ~ 20mA Detect Sel = Alarm Only]</i> <i>b5-01 ≠ 0 [PID Mode Setting ≠ Disabled]</i> <i>H3-01 or H3-09 = 2 [Terminal A1/A2 Signal Level Selection = 4 to 20 mA]</i> 	Make sure that you install the PID feedback source and it operates correctly.
FLGT	Feedback Loss, Go To Freq b5-83	<p>The analog input from the terminal set to <i>H3-xx = B [MFAI Function Selection = PID Feedback]</i> is more than 21 mA or less than 3 mA for longer than 1 s in these conditions:</p> <ul style="list-style-type: none"> <i>b5-82 = 3 [Feedback Loss 4 ~ 20mA Detect Sel = Run At b5-83]</i> <i>b5-01 ≠ 0 [PID Mode Setting ≠ Disabled]</i> <i>H3-01 or H3-09 = 2 [Terminal A1/A2 Signal Level Selection = 4 to 20 mA]</i> 	Make sure that you install the PID feedback source and it operates correctly.
FIRE_ST	Fire Stat Open	The bypass detected a Fire Stat condition.	<ul style="list-style-type: none"> Check the digital input programmed for Fire Stat Switch (Z2-0x = 38). Check the connected device for continuity. Check Bypass Digital Input Invert Settings in Z2-09 to Z2-16.
FREEZ_ST	Freeze Stat Open	The bypass detected a Freeze Stat condition.	<ul style="list-style-type: none"> Check the digital input programmed for Freeze Stat Switch (Z2-0x = 39). Check the connected device for continuity. Check Bypass Digital Input Invert Settings in Z2-09 to Z2-16.
FR<MS	Freq Ref < Minimum Speed (Y1-06)	<p>The drive frequency reference setting is less than the value set in <i>Y1-06 [Minimum Speed]</i> in these conditions:</p> <ul style="list-style-type: none"> The drive is not in PI Mode The drive is running <i>Minimum Speed</i> is enabled (<i>Y1-06 > 0.00</i>) <i>Y1-06 > Y4-12 [Thrust Frequency]</i> 	Increase the frequency reference to a value more than <i>Y1-06</i> .

5 Troubleshooting

Code	Name	Causes	Possible Solutions
FR<TH	Freq. Reference < Thrust (Y4-12)	The drive frequency reference setting is less than the value set in Y4-12 [Thrust Frequency] in these conditions: <ul style="list-style-type: none"> The drive is not in PI Mode The drive is running Thrust is enabled (Y4-11 [Thrust Acceleration Time] > 0.00 and Y4-12 > Y1-06 [Minimum Speed]) 	Increase the frequency reference to a value more than Y4-12.
HCA	High Current Alarm	The load is too heavy.	<ul style="list-style-type: none"> Decrease the load for applications with repetitive starts and stops. Replace the drive with a larger capacity model.
		The acceleration time is too short.	<ul style="list-style-type: none"> Calculate the torque necessary during acceleration related to the load inertia and the specified acceleration time. Increase the values set in C1-01 or C1-03 [Acceleration Times] until you get the necessary torque. Increase the values set in C2-01 to C2-04 [S-Curve Characteristics] until you get the necessary torque. Replace the drive with a larger capacity model.
		The drive is trying to operate a specialized motor or a motor that is larger than the maximum applicable motor output of the drive.	<ul style="list-style-type: none"> Examine the motor nameplate, the motor, and the drive to make sure that the drive rated current is larger than the motor rated current. Replace the drive with a larger capacity model.
		The current level temporarily increased because of speed search after a momentary power loss or while trying to Auto Restart.	If speed search or Auto Restart cause an increase in current, the drive can temporarily show this alarm. The time that the drive shows the alarm is short. No more steps are necessary to clear the alarm.
HIAUX	High PI Aux Feedback Level	PI Auxiliary Feedback is more than the level set in YF-12 [PI Aux Control High Level Detect] for the time set in YF-13 [PI Aux High Level Detection Time] in these conditions: <ul style="list-style-type: none"> The drive operates in AUTO Mode. The output frequency > 0. 	<ul style="list-style-type: none"> Decrease the PI Auxiliary Feedback level to less than YF-12. Set YF-12 and YF-13 correctly.
HIFB	High Feedback Sensed	The feedback level is more than the level set in Y1-11 [High Feedback Level].	<ul style="list-style-type: none"> Decrease the feedback level to less than Y1-11 - Y1-14 [Hysteresis Level]. Set Y1-11 and Y1-12 correctly.
HWL	High Water Level	The "High Water (NC)" digital input is open [Z2-0x = 49] and input is non-inverted [Z2-0x = 0] or the The "High Water NC" digital input is closed [Z2-0x = 49] and input is inverted [Z2-0x = 1].	Raise the water level or adjust the "High Water Level" switch.
INTLK	BAS Interlock	The digital input terminal set to H1-xx = B2 [MFDI Function Selection = BAS Interlock] deactivates.	Make sure the cause of interlock.
L24v	Loss of External Power 24 Supply	The voltage of the backup 24 V power supply has decreased. The main circuit power supply is operating correctly.	<ul style="list-style-type: none"> Examine the external 24 V power supply for disconnected wires and wiring errors and repair the problems. Examine the external 24 V power supply for problems.
LCP	Low City Pressure	Insufficient pressure is present on the inlet to the pump in these conditions: <ul style="list-style-type: none"> Y4-24 = 0 [Low City Alarm Text = Low City Pressure] The terminal set for Z2-0x = 46 [Bypass MFDI Function Selection - Low City Pressure] activates 	<ul style="list-style-type: none"> Examine the pressure switch contact for correct operation. Make sure that control wiring to drive terminal strip from pressure switch contact. Make sure that suction pressure is present with an isolated measuring device. Set Y4-22 [Low City On-Delay Time] and Y4-23 [Low City Off-Delay Time] correctly. Deactivate the digital input terminals set to Z2-0x = 46 [Bypass MFDI Function Selection - Low City Pressure].
LOAUX	Low PI Aux Feedback Level	When the drive operates in AUTO Mode or HAND Mode, PI Auxiliary Feedback is less than the level set in YF-09 [PI Aux Control Low Lvl Detection] for the time set in YF-10 [PI Aux Control Low Lvl Det Time] and the drive is running.	<ul style="list-style-type: none"> Increase the PI Auxiliary Feedback level more than YF-09. Set YF-09 and YF-10 correctly.
LOFB	Low Feedback Sensed	The feedback level is less than the level set in Y1-08 [Low Feedback Level] for the time set in Y1-09 [Low Feedback Lvl Fault Dly Time].	<ul style="list-style-type: none"> Increase the feedback level to more than Y1-08 + Y1-14 [High Feedback Hysteresis Level]. Set Y1-08 and Y1-09 correctly.
LoG	Com Error / Abnormal SD Card	There is not a micro SD card in the keypad.	Put a micro SD card in the keypad.
		<ul style="list-style-type: none"> The drive is connected to USB. The number of log communication files is more than 1000. The micro SD card does not have available memory space. The line number data in a log communication file was changed. A communication error between the keypad and drive occurred during a log communication. 	Set o5-01 = 0 [Log Start/Stop Selection = OFF].

Code	Name	Causes	Possible Solutions
LOP	Loss of Prime	The pump load that measured based on the <i>Y1-18 [Prime Loss Detection Method]</i> setting is less than the level set in <i>Y1-19 [Prime Loss Level]</i> for the time set in <i>Y1-20 [Prime Loss Time]</i> , and the output frequency is <i>Y1-21 [Prime Loss Activation Freq]</i> or more.	<ul style="list-style-type: none"> Examine a dry well, air in the system, or no water in the system. Use preferred priming method suggested by the pump manufacturer to restart the pump. When there is resistance in the pump, allow the system to pump water again. Set <i>Y1-18</i> to <i>Y1-21</i> correctly.
LOW_SUCT	Low Suction Detected	The bypass detected a Low Suction condition.	<ul style="list-style-type: none"> Check the digital input programmed for Low Suction Switch (<i>Z2-0x = 42</i>). Check the connected device for continuity. Check Bypass Digital Input Invert Settings in <i>Z2-09</i> to <i>Z2-16</i>.
LSP	Low Suction Pressure	An external input has indicated that an insufficient suction pressure condition exists in these conditions: <ul style="list-style-type: none"> <i>Y4-24 = 1 [Low City Alarm Text = Low Suction Pressure]</i> The terminal set for <i>H1-xx = B8</i> or <i>1B8 [MFDI Function Selection = Low City Pressure or !Low City Pressure]</i> activates 	<ul style="list-style-type: none"> Examine the pressure switch contact for correct operation. Make sure that control wiring to drive terminal strip from pressure switch contact. Make sure that suction pressure is present with an isolated measuring device. Increase the system pressure. Set <i>Y4-22 [Low City On-Delay Time]</i> and <i>Y4-23 [Low City Off-Delay Time]</i> correctly. Deactivate the digital input terminals set to <i>H1-xx = B8</i> or <i>1B8</i>.
LT-1	Cooling Fan Maintenance Time	The cooling fan is at 90% of its performance life estimate.	<ol style="list-style-type: none"> Replace the cooling fan. Set <i>o4-03 = 0 [Fan Operation Time Setting = 0 h]</i> to reset the cooling fan operation time.
LT-2	Capacitor Maintenance Time	The capacitors for the main circuit and control circuit are at 90% of their performance life estimate.	Replace the control board or the drive. For information about replacing the control board, contact Yaskawa or your nearest sales representative.
LT-3	SoftChargeBypassRelay MainteTime	The soft charge bypass relay is at 90% of its performance life estimate.	Replace the control board or the drive. For information about replacing the control board, contact Yaskawa or your nearest sales representative.
LT-4	IGBT Maintenance Time (50%)	The IGBT is at 50% of its performance life estimate.	Check the load, carrier frequency, and output frequency.
LWL	Low Water Level	The "Low Water (NC)" digital input is open [<i>Z2-0x = 48</i>] and input is non-inverted [<i>Z2-0x = 0</i>] or the The "Low Water NC" digital input is closed [<i>Z2-0x = 48</i>] and input is inverted [<i>Z2-0x = 1</i>].	Raise the water level or adjust the "Low Water Level" switch.
LWT	Low Water In Tank	An external input has indicated that the water level in the tank is too low in these conditions: <ul style="list-style-type: none"> <i>Y4-24 = 2 [Low City Alarm Text = Low Water in Tank]</i> The terminal set for <i>H1-xx = B8</i> or <i>1B8 [MFDI Function Selection = Low City Pressure or !Low City Pressure]</i> activates 	<ul style="list-style-type: none"> Examine the pressure switch contact for correct operation. Make sure that control wiring to drive terminal strip from pressure switch contact. Make sure that suction pressure is present with an isolated measuring device. Increase the water level. Set <i>Y4-22 [Low City On-Delay Time]</i> and <i>Y4-23 [Low City Off-Delay Time]</i> correctly. Deactivate the digital input terminals set to <i>H1-xx = B8</i> or <i>1B8</i>.
NMS	Setpoint Not Met	The feedback deviates from the setpoint at a level more than <i>Y1-15 [Maximum Setpoint Difference]</i> for the time set in <i>Y1-16 [Not Maintaining Setpoint Time]</i> .	<ul style="list-style-type: none"> Examine for a blocked impeller, over cycling, or broken pipe. Set <i>Y1-15</i> and <i>Y1-16</i> correctly.
OD	Output Disconnect	The output circuit between the drive and the motor is open, and the drive output current is less than 5% of <i>E2-01 [Motor Rated Current (FLA)]</i> .	<ul style="list-style-type: none"> Close the disconnected output circuit between the drive and the motor. If you do not use a motor disconnect, set <i>Y4-42 = 0 [Disabled]</i>.
oH	Heatsink Overheat	The ambient temperature is high and the heatsink temperature is more than the <i>L8-02 [Overheat Alarm Level]</i> .	<ul style="list-style-type: none"> Measure the ambient temperature. Increase the airflow around the drive. Install a cooling device (cooling fan or air conditioner) to decrease the ambient temperature. Remove objects near the drive that are producing too much heat.
		There is not sufficient airflow around the drive.	<ul style="list-style-type: none"> Give the drive the correct installation space as shown in the manual. Make sure that there is sufficient circulation around the control panel. Examine the drive for dust or other unwanted materials that could clog the cooling fan. Remove unwanted materials that prevent air circulation.
		The internal cooling fan or fans stopped.	<ol style="list-style-type: none"> Replace the cooling fan. Set <i>o4-03 = 0 [Fan Operation Time Setting = 0 h]</i> to reset the cooling fan operation time.
oH2	External Overheat (H1-XX=B)	An external device sent an <i>oH2</i> alarm.	<ol style="list-style-type: none"> Find the external device that output the overheat alarm. Remove the cause of the problem. Clear the <i>Overheat Alarm (oH2) [H1-xx = B]</i> in MFDI terminals S1 to S8.

5 Troubleshooting

Code	Name	Causes	Possible Solutions
oH3	Motor Overheat (PTC Input)	The thermistor wiring that detects motor temperature is defective.	Correct wiring errors.
		A fault occurred on the machine. Example: The machine is locked.	Examine the machine and remove the cause of the fault
		The motor has overheated.	<ul style="list-style-type: none"> Check the load level, acceleration/deceleration time, and motor start/stop frequency (cycle time). Decrease the load. Increase the values set in <i>C1-01 to C1-04 [Acceleration/Deceleration Times]</i>. Set <i>E2-01 [Motor Rated Current (FLA)]</i> correctly to the value specified by the motor nameplate. Make sure that the motor cooling system is operating correctly, and repair or replace it if it is damaged. Adjust <i>E1-04 to E1-10 [V/f Pattern Parameters]</i>. Decrease the values set in <i>E1-08 [Mid Point A Voltage]</i> and <i>E1-10 [Minimum Output Voltage]</i>. <p>Note: If the values set in <i>E1-08</i> and <i>E1-10</i> are too low, the overload tolerance will decrease at low speeds.</p>
oL3	Overtorque 1	A fault occurred on the machine. Example: The machine is locked.	Examine the machine and remove the cause of the fault.
		The parameters are incorrect for the load.	Adjust <i>L6-02 [Torque Detection Level 1]</i> and <i>L6-03 [Torque Detection Time 1]</i> settings.
oL4	Overtorque 2	A fault occurred on the machine. Example: The machine is locked.	Examine the machine and remove the cause of the fault.
		The parameters are incorrect for the load.	Adjust <i>L6-05 [Torque Detection Level 2]</i> and <i>L6-06 [Torque Detection Time 2]</i> settings.
ov	DC Bus Overvoltage	The drive output cable or motor is shorted to ground (the current short to ground is charging the main circuit capacitor of the drive through the power supply).	<ol style="list-style-type: none"> Examine the motor main circuit cable, terminals, and motor terminal box, and then remove ground faults. Re-energize the drive.
		The power supply voltage is too high.	Decrease the power supply voltage to align with the drive rated voltage.
		Electrical interference caused a drive malfunction.	<ul style="list-style-type: none"> Examine the control circuit lines, main circuit lines, and ground wiring, and minimize the effects of noise. Find the source of the noise. If a magnetic contactor is the source, use Surge Protective Device if necessary. Set <i>L5-01 ≠ 0 [Number of Auto-Restart Attempts ≠ 0 times]</i>.
ovEr	Too Many Parameters Changed	You tried to change more than 150 parameters.	<p>Make sure that parameters that do not have an effect on drive operation are at their default settings.</p> <p>Note:</p> <ul style="list-style-type: none"> You can change 150 parameters maximum. If you change parameters that have dependencies, the drive can detect <i>ovEr</i> when the number of changed parameters is fewer than 150.
OV_PRESS	Over Pressure Detected	The bypass detected an Over Pressure condition.	<ul style="list-style-type: none"> Check the digital input programmed for Over Pressure Switch (<i>Z2-0x = 41</i>). Check the connected device for continuity. Check Bypass Digital Input Invert Settings in <i>Z2-09 to Z2-16</i>.
PA1	PLC Error 1	The network speed on one port does not align with the network speed on the other port.	Make sure that the network speeds on both ports are the same.
PASS	Serial Communication Test	The serial communications test is complete.	The <i>PASS</i> display will turn off after communications test mode is cleared.
PF	Input Phase Loss	There is a phase loss in the drive input power.	Correct errors with the wiring for main circuit drive input power.
		Loose wiring in the input power terminals.	Tighten the terminal screws to the correct tightening torque.
		The drive input power voltage is changing too much.	<ul style="list-style-type: none"> Examine the input power for problems. Make the drive input power stable.
		Unsatisfactory balance between voltage phases.	<ul style="list-style-type: none"> Examine the input power for problems. Make the drive input power stable. If the input power supply is good, examine the magnetic contactor on the main circuit side for problems.

Code	Name	Causes	Possible Solutions
		The main circuit capacitors are unserviceable.	<ul style="list-style-type: none"> Examine the capacitor maintenance time in monitor <i>U4-05 [CapacitorMaintenance]</i>. If <i>U4-05</i> is more than 90%, replace the capacitor. Contact Yaskawa or your nearest sales representative for more information.
			<ul style="list-style-type: none"> Examine the input power for problems. Re-energize the drive. If the alarm stays, replace the circuit board or the drive. Contact Yaskawa or your nearest sales representative for more information.
SAFE	Safety Open	The bypass detected a Open Safety condition.	<ul style="list-style-type: none"> Check the digital input programmed for Run Enable - Safety (NC) <i>Z2-0x = 22</i>. Check the connected device for continuity. Check the Bypass Digital Input Invert settings in <i>Z2-09 to Z2-16</i>.
SE	Modbus Test Mode Error	Serial Hardware communications self-diagnostics [<i>Z2-xx = 45</i>] was done while the drive was running.	Stop the drive and do MEMOBUS/Modbus communications self-diagnostics.
SMK_ALARM	Smoke Alarm Active	The bypass detected a Smoke Alarm condition.	<ul style="list-style-type: none"> Check the digital input programmed for Smoke Alarm (<i>Z2-0x = 40</i>). Check the connected device for continuity. Check Bypass Digital Input Invert Settings in <i>Z2-09 to Z2-16</i>.
STo	Safe Torque OFF	Safe Disable inputs H1-HC and H2-HC are open.	<ul style="list-style-type: none"> Make sure that the Safe Disable signal is input from an external source to terminal H1-HC and H2-HC. When the Safe Disable function is not in use, use a jumper to connect terminals H1-HC and H2-HC.
		There is internal damage to the two Safe Disable channels.	Replace the board or the drive. Contact Yaskawa or your nearest sales representative to replace the board.
SToF	Safe Torque OFF Hardware	One of the two terminals H1-HC or H2-HC received the Safe Disable input signal.	<ul style="list-style-type: none"> Make sure that the Safe Disable signal is input from an external source to terminals H1-HC or H2-HC.
		The Safe Disable input signal is wired incorrectly.	<ul style="list-style-type: none"> When the Safe Disable function is not in use, use a jumper to connect terminals H1-HC and H2-HC.
		There is internal damage to one Safe Disable channel.	Replace the board or the drive. Contact Yaskawa or your nearest sales representative to replace the board.
TiM	Keypad Time Not Set	There is a battery in the keypad, but you have not set the date and time.	Use the keypad to set the date and time.
TrPC	IGBT Maintenance Time (90%)	The IGBT is at 90% of its performance life estimate.	Replace the IGBT or the drive. For more information, contact Yaskawa or your nearest sales representative.
UL3	Undertorque Detection 1	A fault occurred on the machine. Example: There is a broken pulley belt.	Examine the machine and remove the cause of the fault.
		The parameters are incorrect for the load.	Adjust <i>L6-02 [Torque Detection Level 1]</i> and <i>L6-03 [Torque Detection Time 1]</i> settings.
UL4	Undertorque Detection 2	A fault occurred on the machine. Example: There is a broken pulley belt.	Examine the machine and remove the cause of the fault.
		The parameters are incorrect for the load.	Adjust <i>L6-05 [Torque Detection Level 2]</i> and <i>L6-06 [Torque Detection Time 2]</i> settings.
UL6	Underload or Belt Break Detected	The output current decreased less than the motor underload curve set in <i>L6-14 [Motor Underload Level @ Min Freq]</i> for longer than the time set in <i>L6-03 [Torque Detection Time 1]</i> .	Examine parameters <i>L6-13 [Motor Underload Curve Select]</i> and <i>L6-14</i> .
		The belt has broken disconnecting the motor from the load.	
Uv	Undervoltage	The drive input power voltage is changing too much.	<ul style="list-style-type: none"> Examine the input power for problems. Make the drive input power stable. If the input power supply is good, examine the magnetic contactor on the main circuit side for problems.
		There is a phase loss in the drive input power.	Correct errors with the wiring for main circuit drive input power.
		There is loose wiring in the drive input power terminals.	Tighten the terminal screws to the correct tightening torque.
		There was a loss of power.	Use a better power supply.
		The main circuit capacitors have become unserviceable.	Examine the capacitor maintenance time in monitor <i>U4-05 [CapacitorMaintenance]</i> . If <i>U4-05</i> is more than 90%, replace the control board or the drive. For information about replacing the control board, contact Yaskawa or your nearest sales representative.

Code	Name	Causes	Possible Solutions
		The drive input power transformer is too small and voltage drops when the power is switched on.	<ul style="list-style-type: none"> Check for an alarm when a molded-case circuit breaker, Leakage Breaker (ELCB or GFCI) (with overcurrent protective function), or magnetic contactor is ON. Check the capacity of the drive power supply transformer.
VBRATION	Vibration Detected	The bypass detected a Vibration condition.	<ul style="list-style-type: none"> Check the digital input programmed for Vibration Switch (Z2-0x = 43). Check the connected device for continuity. Check Bypass Digital Input Invert Settings in Z2-09 to Z2-16.

◆ Parameter Setting Errors

Parameter setting errors occur when multiple parameter settings do not agree, or when parameter setting values are not correct. Refer to the table in this section, examine the parameter setting that caused the error, and remove the cause of the error. You must first correct the parameter setting errors before you can operate the drive. The drive will not send notification signals for the faults and alarms when these parameter setting errors occur.

Code	Name	Causes	Possible Solutions
oPE01	Drive Capacity Setting Error	The value set in <i>o2-04 [Drive Model (KVA) Selection]</i> does not agree with the drive model.	Consult Yaskawa technical support.
oPE02	Parameter Range Setting Error	Parameters settings are not in the applicable setting range.	<ol style="list-style-type: none"> Push  to show <i>U1-18 [oPE Fault Parameter]</i>, and find parameters that are not in the applicable setting range. Correct the parameter settings. <p>Note: If more than one error occurs at the same time, other <i>oPExx</i> errors have priority over <i>oPE02</i>.</p>
		You set $E2-01 \leq E2-03$ [<i>Motor Rated Current (FLA) ≤ Motor No-Load Current</i>].	Make sure that $E2-01 > E2-03$. Note: If it is necessary to set $E2-01 < E2-03$, first lower the value set in <i>E2-03</i> , and then set <i>E2-01</i> .
		You set $S3-09 < S3-10$ [<i>PI2 Control Output Upper Limit < PI2 Control Output Lower Limit</i>].	Make sure that $S3-09 > S3-10$ at all times.
		You set $S3-13 > S3-15$ [<i>PI2 Control Low Feedback Lvl > PI2 Control High Feedback Lvl</i>].	Make sure that $S3-13 < S3-15$ at all times.
oPE03	Multi-Function Input Setting Err	The settings for these parameters do not agree: <ul style="list-style-type: none"> <i>Z2-01 to Z2-08 [Digital Input 1 Function (TB2-1) to Digital Input 8 Function (TB2-8)]</i> <i>H1-01 to H1-08 [Terminals S1 to S8 Function Selection]</i> 	Correct the parameter settings.
		The settings for the bypass MFDIs <i>Z2-01 to Z2-08</i> overlap and/or the setting for the drive MFDIs <i>H1-01 to H1-07</i> overlap Note: This does not include <i>H1-xx = 20 to 2F [MFDI Function Selection = External Fault]</i> .	Check the settings and make sure that you did not program two or more MFDIs to the same value.
		A minimum of two of these MFDI combinations are set to Digital Inputs (<i>H1-xx</i> and <i>H7-01 to H7-04</i>) at the same time: <ul style="list-style-type: none"> Setting value <i>1E [Reference Sample Hold]</i> Setting values <i>44 to 46 [Add Offset Frequency 1 to 3 (d7-01 to d7-03)]</i> 	Remove the function settings that are not in use.
		These commands are set in Digital Inputs (<i>H1-xx</i> and <i>H7-01 to H7-04</i>) at the same time: <ul style="list-style-type: none"> Setting values <i>61 [Speed Search from Fmax]</i> and <i>62 [Speed Search from Fref]</i> 	Remove the function settings that are not in use.
		These groups of MFDI functions are not set to Digital Inputs (<i>H1-xx</i> and <i>H7-01 to H7-04</i>) at the same time: <ul style="list-style-type: none"> Setting values <i>3E [PID Setpoint Selection 1]</i> and <i>3F [PID Setpoint Selection 2]</i> Setting values <i>83 [Dedicated Multi-Setpoint YA-02]</i>, <i>84 [Dedicated Multi-Setpoint YA-03]</i>, and <i>85 [Dedicated Multi-Setpoint YA-04]</i> 	Set the MFDI groups correctly.
		Settings for N.C. and N.O. input [<i>H1-xx</i>] for these functions were selected at the same time: <ul style="list-style-type: none"> Setting value <i>15 [Fast Stop (N.O.)]</i> Setting value <i>17 [Fast Stop (N.C.)]</i> 	Remove one of the function settings.

Code	Name	Causes	Possible Solutions
		These MFDI functions are set at the same time: <ul style="list-style-type: none"> • $H1-xx = 6A$ [Drive Enable] • $H1-xx = 70$ [Drive Enable 2] 	Remove one of the function settings.
		These parameters are set at the same time: <ul style="list-style-type: none"> • $H1-xx = 62$ [Speed Search from Fref] • $H5-22 = 1$ [Speed Search from MODBUS = Enabled] 	Remove one of the function settings.
		Parameter $S3-01 \neq 0$ [PI2 Control Enable Selection \neq Disabled] and MFDI set for $H1-xx = AD$ [Select PI2 Control PI Parameters] is ON or MFDI set for $H1-xx = 1AD$ [!Select PI2 Control PI Parameters] is OFF.	<ul style="list-style-type: none"> • Set $S3-01 = 0$ to use $H1-xx = AD$ or $1AD$ for the adjustments of $S3-06$ [PI2 Control Proportional Gain] and $S3-07$ [PI2 Control Integral Time] instead of the primary PI controller Proportional and Integral adjustments. • When PI2 Control is necessary, remove the MFDI function setting.
oPE05	Run Cmd/Freq Ref Source Sel Err	There is an option card installed on the drive.	Remove the option card from the drive. If it is compatible, install the option card on the bypass control board.
		The setting to assign the Run command or frequency reference to an option card is incorrect.	Correct the parameter settings.
		$Z1-39 = 3$ [Drive/Bypass Source Select = Option PCB] is set, but there is no option card connected.	Connect an option card.
		$b1-01 = 3$ [Frequency Reference Selection 1 = Option PCB] is set, but there is no option card connected.	
	$b1-02 = 3$ [Run Command Selection 1 = Option PCB] is set, but there is no option card connected.		
oPE07	Analog Input Selection Error	The settings for $H3-02$, $H3-06$, $H3-10$ [MFAI Function Selection] and $H7-30$ [Virtual Analog Input Selection] overlap.	Set $H3-02$, $H3-06$, $H3-10$, and $H7-30$ correctly to prevent overlap. Note: It is possible to set these functions to multiple analog input terminals at the same time: <ul style="list-style-type: none"> • Setting value 0 [Frequency Reference] • Setting values F and $1F$ [Not Used]
		These parameters are set at the same time: <ul style="list-style-type: none"> • $H3-02$, $H3-06$, $H3-10$, $H7-30 = B$ [PID Feedback] • $H6-01 = 1$ [Terminal RP Pulse Train Function = PID Feedback Value] 	Remove the function settings that are not in use.
		These parameters are set at the same time: <ul style="list-style-type: none"> • $H3-02$, $H3-06$, $H3-10$, $H7-30 = C$ [PID Setpoint] • $H6-01 = 2$ [PID Setpoint Value] 	
		These parameters are set at the same time: <ul style="list-style-type: none"> • $H3-02$, $H3-06$, $H3-10$, $H3-40$, $H3-41$, $H3-42$, $H7-30 = 24$ [PID Feedback Backup] • $Y4-41 = 1$ [Diff Lvl Src Fdbk Backup Select = Enabled] 	<ul style="list-style-type: none"> • Use only $H3-xx = 2D$ [Differential Level Source] as a backup PID feedback and remove the function setting of $H3-xx = 24$. • Use $H3-xx = 24$ as a backup PID feedback and set $Y4-41 = 0$ [Disabled] to not let the drive use $H3-xx = 2D$ as a backup PID feedback.
		These parameters are set at the same time when $F2-01 = 2$ [Analog Input Function Selection = 3 Additional Channels]: <ul style="list-style-type: none"> • $F2-05$, $F2-09$, $F2-13$ [Terminal Vx Function Selection], $H3-40$, $H3-41$, $H3-42 = B$ [PID Feedback] • $H6-01 = 1$ 	<ul style="list-style-type: none"> • Remove the function settings that are not in use. • When you use $H6-01$ and $F2-05$, $F2-09$, $F2-13$ at the same time, set $F2-01 \neq 2$.
		These parameters are set at the same time when $F2-01 = 2$: <ul style="list-style-type: none"> • $F2-05$, $F2-09$, $F2-13$, $H3-40$, $H3-41$, $H3-42 = C$ [PID Setpoint] • $H6-01 = 2$ 	
		The settings for $F2-05$, $F2-09$, and $F2-13$ overlap when $F2-01 = 2$.	<ul style="list-style-type: none"> • Set the parameters correctly to prevent overlap. • Set $F2-01 \neq 2$.
		The settings for $F2-05$, $F2-09$, $F2-13$ and the settings for these parameters overlap when $F2-01 = 2$: <ul style="list-style-type: none"> • $H3-02$, $H3-06$, $H3-10$ • $H3-40$, $H3-41$, $H3-42$ • $H7-30$ 	
		The settings for these parameters overlap: <ul style="list-style-type: none"> • $H3-02$, $H3-06$, $H3-10$ • $H3-40$, $H3-41$, $H3-42$ • $H7-30$ 	Set these parameters correctly to prevent overlap

5 Troubleshooting

Code	Name	Causes	Possible Solutions
oPE08	Parameter Selection Error	You set these parameters: <ul style="list-style-type: none"> • $S1-01 = 1$ [Dynamic Noise Control = Enabled] • $Y4-42 \neq 0$ [Output Disconnect Detection Sel ≠ Disabled] 	Set $S1-01 = 0$ or $Y4-42 = 0$.
		You set $L6-02$ [Torque Detection Level 1] < $L6-14$ [Motor Underload Level @ Min Freq].	Set parameters to be $L6-02 \geq L6-14$.
oPE09	PID Control Selection Fault	These parameters are set at the same time: <ul style="list-style-type: none"> • $b5-01 = 1$ • $b5-11 = 1$ [PID Output Reverse Selection = Negative Output Accepted] And one of these parameters is set: <ul style="list-style-type: none"> • $d2-02 \neq 0.0$ [Frequency Reference Lower Limit ≠ 0.0%] • $Y1-06 \neq 0.0$ [Minimum Speed ≠ 0.0%] • $Y4-12 \neq 0.0$ [Thrust Frequency ≠ 0.0%] • $YF-01 \neq 0$ [PI Aux Control Selection ≠ Disabled] 	Correct the parameter settings.
		Parameter $b5-01 = 3$ and one of these parameters is set at the same time: <ul style="list-style-type: none"> • $d2-02 \neq 0.0$ • $Y1-06 \neq 0.0$ • $Y4-12 \neq 0.0$ • $YF-01 \neq 0$ 	Correct the parameter settings.
oPE10	V/f Data Setting Error	The parameters that set the V/f pattern do not satisfy these conditions: <ul style="list-style-type: none"> • $E1-09 \leq E1-07 < E1-06 \leq E1-11 \leq E1-04$ [Minimum Output Frequency ≤ Mid Point A Frequency < Base Frequency ≤ Mid Point B Frequency ≤ Maximum Output Frequency] 	Set the parameters correctly to satisfy the conditions.
oPE11	Carrier Frequency Setting Error	These parameters are set at the same time: <ul style="list-style-type: none"> • $C6-05 > 6$ [Carrier Freq Proportional Gain > 6] • $C6-04 > C6-03$ [Carrier Frequency Lower Limit > Carrier Frequency Upper Limit] Note: When $C6-05 < 7$, $C6-04$ becomes disabled. $C6-03$ stays active.	Set $C6-02$ to $C6-05$ correctly.
		$C6-02$ to $C6-05$ settings are not in the applicable setting range.	
oPE16	Energy Saving Constants Error	These parameters are set at the same time: <ul style="list-style-type: none"> • $b8-01 = 1$ [Energy Saving Control Selection = Enabled] • $S1-01 = 1$ [Dynamic Noise Control = Enabled] 	Disable Energy Saving Control or Dynamic Noise Control.
oPE29	Baud Rate Setting Error	The baud rate setting [H5-02] does not align with the currently selected protocol [H5-08]. One of these contradictory settings is true: <ul style="list-style-type: none"> • $H5-08 = 1$ and $H5-02 \neq 3$ [Communication Protocol Selection = Metasys/N2 and Communication Speed Selection ≠ 9600 bps] • $H5-08 = 2$ and $H5-02 \neq 2, 3$ [Communication Protocol Selection = Apogee/P1 and Communication Speed Selection ≠ 4800 bps, 9600 bps] • $H5-08 = 3$ and $H5-02 \neq 3, 4, 5, 7$ [Communication Protocol Selection = BACnet and Communication Speed Selection ≠ 9600 bps, 19.2 kbps, 38.4 kbps, 76.8 kbps] 	Correct the parameter settings.
oPE34	HAND/OFF/AUTO Input Setting	Parameter $b1-02 = 7$ to 9 and only HAND or AUTO MFDI [Z2-0x = 31 or 32] is programmed.	Program HAND and AUTO MFDIs [Z2-0x = 31 and 32].
		Parameter $b1-02 = 1$ to 3 and the AUTO MFDI [Z2-0x = 32] is programmed	Un-program HAND and AUTO MFDIs, so neither are selected.
		Parameter $b1-02 = 0$ and either HAND or AUTO MFDI [Z2-0x = 31 or 32] are programmed.	Un-program the AUTO MFDI.
oPE34	HAND/OFF/AUTO Input Setting	Parameter $b1-02 = 0$ and either HAND or AUTO MFDI [Z2-0x = 31 or 32] are programmed.	Un-program the HAND and AUTO MFDIs.
		Parameter $b1-02 = 1$ to 3 and the AUTO MFDI [Z2-0x = 32] is programmed	Un-program the AUTO MFDI.
		Parameter $b1-02 = 7$ to 9 and only HAND or AUTO MFDI [Z2-0x = 31 or 32] is programmed.	Program HAND and AUTO MFDIs [Z2-0x = 31 and 32].
oPE36	Bypass Energy Savings Setting Err	These parameters are set at the same time: <ul style="list-style-type: none"> • $Z1-16 \neq 0$ [Energy Savings Mode ≠ Disabled] • $Y4-42 \neq 0$ [Output Disconnect Detection Sel ≠ Disabled] 	Set $Z1-16$ or $Y4-42 = 0$.

◆ Auto-Tuning Errors

This table gives information about errors detected during Auto-Tuning. If the drive detects an Auto-Tuning error, the keypad will show the error and the motor will coast to stop. The drive will not send notification signals for faults and alarms when Auto-Tuning errors occur.

Two types of Auto-Tuning errors are: *Endx* and *Erx*. *Endx* identifies that Auto-Tuning has successfully completed with calculation errors. Find and repair the cause of the error and do Auto-Tuning again, or set the motor parameters manually. You can use the drive in the application if you cannot find the cause of the *Endx* error.

Erx identifies that Auto-Tuning was not successful. Find and repair the cause of the error and do Auto-Tuning again.

Code	Name	Causes	Possible Solutions
End1	Excessive Rated Voltage Setting	The torque reference was more than 20% during Auto-Tuning or the no-load current that was measured after Auto-Tuning is more than 80%.	<ul style="list-style-type: none"> Make sure that the input motor nameplate data is correct. Do Auto-Tuning again and correctly set the motor nameplate data. If you can uncouple the motor and load, remove the motor from the machine and do Rotational Auto-Tuning again. If you cannot uncouple the motor and load, use the results from Auto-Tuning.
End2	Iron Core Saturation Coefficient	The motor nameplate data entered during Auto-Tuning is incorrect.	<ul style="list-style-type: none"> Make sure that the input motor nameplate data is correct. Do Auto-Tuning again and correctly set the motor nameplate data.
End3	Rated Current Setting Alarm	The rated current value is incorrect.	Do Auto-Tuning again and set the correct rated current shown on the motor nameplate.
End4	Adjusted Slip Calculation Error	The Auto-Tuning results were not in the applicable parameter setting range.	<ul style="list-style-type: none"> Make sure the input motor nameplate data is correct. Do Rotational Auto-Tuning again and correctly set the motor nameplate data. If you cannot uncouple the motor and load, do Stationary Auto-Tuning 2.
		The motor rated slip that was measured after Stationary Auto-Tuning was 0.2 Hz or lower.	
		The secondary resistor measurement results were not in the applicable range.	
End5	Resistance Tuning Error	The Auto-Tuning results of the Line-to-Line Resistance were not in the applicable range.	<ul style="list-style-type: none"> Make sure that the input motor nameplate data is correct. Examine and repair damaged motor wiring.
End6	Leakage Inductance Alarm	The Auto-Tuning results were not in the applicable parameter setting range.	Make sure that the input motor nameplate data is correct, and do Auto-Tuning again.
End7	No-Load Current Alarm	The Auto-Tuning results of the motor no-load current value were not in the applicable range.	Examine and repair damaged motor wiring.
		Auto-Tuning results were less than 5% of the motor rated current.	Make sure that the input motor nameplate data is correct, and do Auto-Tuning again.
Er-01	Motor Data Error	The motor nameplate data entered during Auto-Tuning is incorrect.	<ul style="list-style-type: none"> Make sure that the motor nameplate data is correct. Do Auto-Tuning again and correctly set the motor nameplate data.
		The combination of the motor rated power and motor rated current do not match.	<ul style="list-style-type: none"> Examine the combination of drive capacity and motor output. Do Auto-Tuning again, and correctly set the motor rated power and motor rated current.
		The combination of the motor rated current that was entered during Auto-Tuning and <i>E2-03 [Motor No-Load Current]</i> do not match.	<ul style="list-style-type: none"> Examine the motor rated current and the no-load current. Set <i>E2-03</i> correctly. Do Auto-Tuning again, and correctly set the motor rated current.
		The combination of the setting values of Motor Base Frequency and Motor Base Speed do not match.	Do Auto-Tuning again, and correctly set the Motor Base Frequency and Motor Base Speed.
Er-02	Drive in an Alarm State	The motor nameplate data entered during Auto-Tuning is incorrect.	<ul style="list-style-type: none"> Make sure that the motor nameplate data entered in Auto-Tuning is correct. Do Auto-Tuning again and correctly set the motor nameplate data.
		You did Auto-Tuning while the drive had a minor fault or alarm.	Clear the minor fault or alarm and do Auto-Tuning again.
		There is a defective motor cable or cable connection.	Examine and repair motor wiring.
		The load is too large.	<ul style="list-style-type: none"> Decrease the load. Examine the machine area to see if, for example, the motor shaft is locked.
		The drive detected a minor fault during Auto-Tuning.	<ol style="list-style-type: none"> Stop Auto-Tuning. Examine the minor fault code and remove the cause of the problem. Do Auto-Tuning again.

5 Troubleshooting

Code	Name	Causes	Possible Solutions
Er-03	OFF Button was Pressed	You pushed  during Auto-Tuning.	Auto-Tuning did not complete correctly. Do Auto-Tuning again.
Er-04	Line-to-Line Resistance Error	The Auto-Tuning results were not in the applicable parameter setting range.	<ul style="list-style-type: none"> Examine and repair motor wiring. Disconnect the machine from the motor and do Rotational Auto-Tuning again.
		Auto-Tuning did not complete in a pre-set length of time.	
		There is a defective motor cable or cable connection.	<ul style="list-style-type: none"> Make sure that the input motor nameplate data is correct. Do Auto-Tuning again and correctly set the motor nameplate data.
		The motor nameplate data entered during Auto-Tuning is incorrect.	
Er-05	No-Load Current Error	The Auto-Tuning results were not in the applicable parameter setting range.	<ul style="list-style-type: none"> Examine and repair motor wiring. Disconnect the machine from the motor and do Rotational Auto-Tuning again.
		Auto-Tuning did not complete in a pre-set length of time.	
		The motor nameplate data entered during Auto-Tuning is incorrect.	<ul style="list-style-type: none"> Make sure that the input motor nameplate data is correct. Do Auto-Tuning again and correctly set the motor nameplate data.
		Rotational Auto-Tuning was done with a load that was more than 30% of the rating connected to the motor.	<ul style="list-style-type: none"> Disconnect the machine from the motor and do Rotational Auto-Tuning again. If you cannot uncouple the motor and load, make sure that the load is less than 30% of the motor rating. If a mechanical brake is installed in the motor, release the brake during Rotational Auto-Tuning.
Er-08	Rated Slip Error	The motor nameplate data entered during Auto-Tuning is incorrect.	<ul style="list-style-type: none"> Make sure that the input motor nameplate data is correct. Do Auto-Tuning again and correctly set the motor nameplate data.
		Auto-Tuning did not complete in a pre-set length of time.	<ul style="list-style-type: none"> Examine and repair the motor wiring. If the motor and machine are connected during Rotational Auto-Tuning, decouple the motor from the machinery.
		The Auto-Tuning results were not in the applicable parameter setting range.	
		Rotational Auto-Tuning was done with a load that was more than 30% of the rating connected to the motor.	<ul style="list-style-type: none"> Disconnect the machine from the motor and do Rotational Auto-Tuning again. If you cannot uncouple the motor and load, make sure that the load is less than 30% of the motor rating. If a mechanical brake is installed in the motor, release the brake during Rotational Auto-Tuning.
Er-09	Acceleration Error	The motor did not accelerate for the specified acceleration time.	<ol style="list-style-type: none"> Increase the value set in <i>C1-01 [Acceleration Time 1]</i>. Disconnect the machine from the motor and do Rotational Auto-Tuning again.
		Rotational Auto-Tuning was done with a load that was more than 30% of the rating connected to the motor.	<ul style="list-style-type: none"> Disconnect the machine from the motor and do Rotational Auto-Tuning again. If you cannot uncouple the motor and load, make sure that the load is less than 30% of the motor rating. If a mechanical brake is installed in the motor, release the brake during Rotational Auto-Tuning.
Er-12	Current Detection Error	There is a phase loss in the wiring between the output terminal block (or motor overload) and the motor.	Examine and repair wiring.
		The current exceeded the current rating of the drive.	<ul style="list-style-type: none"> Check the motor wiring for any short circuits between the wires. Check and turn ON any magnetic contactors used between motors. Replace the control board or the drive. For information about replacing the control board, contact Yaskawa or your nearest sales representative.
		The output current is too low.	
		You tried Auto-Tuning without a motor connected to the drive.	Connect the motor and do Auto-Tuning.
		There was a current detection signal error.	Replace the control board or the drive. For information about replacing the control board, contact Yaskawa or your nearest sales representative.
Er-13	Leakage Inductance Error	The motor rated current value is incorrect.	Correctly set the rated current indicated on the motor nameplate and do Auto-Tuning again.
		The drive could not complete tuning for leakage inductance in fewer than 300 s.	Examine and repair motor wiring.

Code	Name	Causes	Possible Solutions
Er-18	Back EMF Error	The result of the induced voltage tuning was not in the applicable range.	<ol style="list-style-type: none"> 1. Make sure that the input motor nameplate data is correct. 2. Do Auto-Tuning again and correctly set the motor nameplate data.
Er-25	HighFreq Inject Param Tuning Err	The motor data is incorrect.	Do Stationary Auto-Tuning again. Note: If the drive detects <i>Er-25</i> after you do Stationary Auto-Tuning, it is possible that the motor cannot use high frequency injection. For more information, contact Yaskawa or your nearest sales representative.

◆ Backup Function Operating Mode Display and Errors

■ Operating Mode Display

When the drive does backup function tasks with the HOA keypad, the keypad will show the current task. These indicators do not show that an error has occurred.

Keypad Display	Name	Display	State
Drive and Keypad mismatch. Should the parameters be restored?	Detection of inconsistency between the drive and keypad	Normally displayed	The drive detected the connection of a keypad from a different drive. Select [Yes] to copy parameters backed up in the keypad to the connected drive.
Restore Restore from keypad	Restoring parameters	Flashing	The parameters stored in the keypad have been restored to the drive.
End	Backup/restore/verify operation ended normally	Normally displayed	The parameter backup, restore, or verify operation ended normally.
Backup Backup from Drive	Backing up parameters	Flashing	The parameters stored in the drive are being backed up to the keypad.
Verify Keypad & Drive	Verifying parameters	Flashing	The parameter settings stored in the keypad and the parameter settings in the drive align or are being compared.

■ Backup Function Runtime Errors

When an error occurs, the keypad shows a code to identify the error.

The table in this section shows the error codes. Refer to this table to remove the cause of the errors.

Note:

Push any key on the keypad to clear an error.

Code	Name	Causes	Possible Solutions
CPyE	Error Writing Data	Parameter restore did not end correctly.	Restore the parameters.
CSEr	Control Mode Mismatch	The keypad is broken.	Replace the keypad.
dFPS	Drive Model Mismatch	You tried to restore parameters to a different drive model than the one that you backed up.	<ol style="list-style-type: none"> 1. Examine the drive model that you used to back up the parameters. 2. Restore the parameters.
iFEr	Keypad Communication Error	There was a communications error between the keypad and the drive.	Examine the connector or cable connection.
ndAT	Error Received Data	The parameter settings for model and specifications (power supply voltage and capacity) are different between the keypad and the drive.	<ol style="list-style-type: none"> 1. Make sure that drive model and the value set in <i>o2-04 [Drive Model (KVA) Selection]</i> agree. 2. Restore the parameters.
		The parameters are not stored in the keypad.	<ol style="list-style-type: none"> 1. Connect a keypad that has the correct parameters. 2. Restore the parameters.
rdEr	Error Reading Data	You tried to back up the data when <i>o3-02 = 0 [Copy Allowed Selection = Disabled]</i> .	Set <i>o3-02 = 1 [Enabled]</i> and back up again.
vAEr	Voltage Class, Capacity Mismatch	The power supply specifications or drive capacity parameter settings are different between the keypad and the drive.	<ol style="list-style-type: none"> 1. Make sure that drive model and the value set in <i>o2-04 [Drive Model (KVA) Selection]</i> agree. 2. Restore the parameters.
vFyE	Parameters do not Match	The parameters that are backed up in the keypad and the parameters in the drive are not the same.	<ol style="list-style-type: none"> 1. Restore or backup the parameter again. 2. Verify the parameters.

◆ Bypass Status Messages

The bypass HOA keypad will show these status messages on line 1 of the keypad display during the conditions listed below. These are not faults or alarms.

Keypad Display	Description
Powering Up	Shown on initial power up of the bypass system. This message goes away when the power up initialization is complete and communication is established to the drive, or when the bypass determines that the drive is not connected or energized.
Idle	The bypass is in an Idle state with no active Run command. There are no active faults or alarms.
Drive Not Ready	The drive is not in a ready state. The drive will not run if a Run command is asserted. You can run the system in Bypass Mode.
Safety Open	A safety programmed to a bypass digital input is not closed and there is no active Run command. This message will change to an alarm when there is an active Run command.
Fire Stat Open	A Fire Stat safety programmed to a bypass digital input is not closed and there is no active Run command. This message will change to an alarm when there is an active Run command.
Freeze Stat Open	A Freeze Stat safety programmed to a bypass digital input is not closed and there is no active Run command. This message will change to an alarm when there is an active Run command.
Smoke Alarm active	A Smoke Alarm safety programmed to a bypass digital input is not closed and there is no active Run command. This message will change to an alarm when there is an active Run command.
Over Pressure Detected	An Over Pressure safety programmed to a bypass digital input is not closed and there is no active Run command. This message will change to an alarm when there is an active Run command.
Low Suction Detected	A Low Suction safety programmed to a bypass digital input is not closed and there is no active Run command. This message will change to an alarm when there is an active Run command.
Low Water Level Detected	A Low Water safety programmed to a bypass digital input is not closed and there is no active Run command. This message will change to an alarm when there is an active Run Command
Vibration Detected	A Vibration safety programmed to a bypass digital input is not closed and there is no active Run command. This message will change to an alarm when there is an active Run command.
High Water Level Detected	A High Water safety programmed to a bypass digital input is not closed and there is no active Run command. This message will change to an alarm when there is an active Run Command
Interlock Open	Programmed BAS Interlock is not closed. The unit will not run when it receives a Run command.
Drive Pre Running	The drive received a Run command and the drive is entering the programmed pre-run. When the pre-run conditions are finished, the drive will enter drive run.
Drive Run Commanded	The bypass has commanded the drive to run, but it has not yet detected that the drive is running.
Restart Delay Active	There is an active Run Command, but the programmed restart delay is active and the drive cannot run. The keypad shows this display on power-up or when there is a brief power loss to the bypass unit.
Drive Running	The unit is running in Drive Mode.
Drive Stopping	The Run command to the drive was removed, and the drive is ramping to stop.
Running in Bypass	The unit is running in Bypass Mode.
Entering Energy Savings	Energy savings conditions have been detected. This functionality is programmed using parameters Z1-16 through Z1-23. When entering energy savings, the unit is running at the energy savings bump frequency and when it is finished, it will switch into the bypass run state.
Energy Savings Active	Energy Savings Mode is active and the unit is running in Bypass Mode.
Exiting Energy Savings	Energy Savings conditions are no longer present and the unit is leaving Energy Savings and returning to Drive Mode. The exit conditions are when the frequency reference changes from the programmed Energy Savings frequency reference in Z1-17.
Auto Transfer Active	Auto transfer was enabled in Z1-05 and the unit detected a drive fault during an active drive run. The unit will run in Bypass Mode.
Remote Transfer Active	A Remote Transfer was asserted and the unit is currently running in Bypass Mode.
Emergency Override Drive FWD	An Emergency Override Drive FWD was asserted by a bypass digital input or through serial or option board communications to the bypass board.
Emergency Override Drive REV	An Emergency Override Drive REV was asserted by a bypass digital input or through serial or option board communications to the bypass board.
Emergency Override Bypass	An Emergency Override Bypass was asserted by a bypass digital input or through serial or option board communications to the bypass board. This message also appears when Emergency Override Drive was active, there was a drive fault, and Z1-10 = 1 [Transfer to Bypass].
Faulted	The unit is in Drive Mode it detected a drive fault or bypass fault, or the unit is in Bypass Mode and it detected a bypass-specific fault.

Keypad Display	Description
Soft Start On Delay	There is a Run command and the unit is waiting for the programmed on delay time in Z1-43 before asserting the soft starter run.
Soft Starter Ramping down	Parameter Z1-42 = 2 [Ramp to Stop] and the Run command was removed. The soft starter will ramp to stop.

◆ Diagnosing and Resetting Faults

When a fault occurs and the drive stops, do the procedures in this section to remove the cause of the fault, then re-energize the drive.

■ Fault and Power Loss Occur at the Same Time

⚠ WARNING *Crush Hazard. Wear eye protection when you do work on the bypass. If you do not use correct safety equipment, it can cause serious injury or death.*

⚠ WARNING *Electrical Shock Hazard. After the bypass blows a fuse or trips a GFCI, do not immediately energize the bypass or operate peripheral devices. Wait for the time specified on the warning label at a minimum and make sure that all indicators are OFF. Then check the wiring and peripheral device ratings to find the cause of the problem. If you do not know the cause of the problem, contact Yaskawa before you energize the bypass or peripheral devices. If you do not fix the problem before you operate the bypass or peripheral devices, it can cause serious injury or death.*

1. Connect to the USB connector on the bypass PCB and use DriveWizard Industrial software.
2. Connect to the drive, then select “Status & Fault History” to show fault codes and operating status of the bypass immediately before the fault occurred.
3. Use the information in the Troubleshooting tables to remove the fault.

Note:

1. To find the faults that were triggered, check the fault history in U2-02 [Previous Fault]. To find information about drive status (such as frequency, current, and voltage) when the faults were triggered, check U2-03 to U2-20.
2. If the fault display stays after you re-energize the drive, remove the cause of the fault and reset.

■ Fault Occurs Without Power Loss

1. Examine the fault code shown on the keypad.
2. Use the information in the Troubleshooting tables to remove the fault.
3. Do a fault reset.

■ Fault Reset

If a fault occurs, you must remove the cause of the fault and re-energize the drive. [Table 5.5](#) lists the different methods to reset the drive after a fault.

Note:

You must remove the Run command or make sure that the bypass is in the OFF state before you can do a fault reset.

Table 5.5 Fault Reset Methods

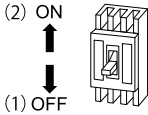
Methods	Description
Method 1	While the keypad is showing the fault or alarm code, push F1 (Reset) or  on the keypad.
Method 2	Switch ON the MFDI Terminal set to Z2-0x = 34 [Bypass MFDI Function Select = Fault Reset].
Method 3	<ol style="list-style-type: none"> 1. De-energize the drive main circuit power supply. 2. Energize the drive again after the keypad display goes out. 

Note:

If the drive receives a Run command from a communication option or control circuit terminal, the drive will not reset the fault. Remove the Run command then try to clear the fault. If you do a fault reset when the drive has a Run command, the keypad will show minor fault CrST [Remove RUN Command to Reset].

6 Specifications

◆ Section Safety

⚠ DANGER Do not ignore the safety messages in this manual. If you ignore the safety messages in this manual, it will cause serious injury or death. The manufacturer is not responsible for injuries or damage to equipment.

◆ 208 V Enclosed Model Specifications

Table 6.1 208 V Enclosed Ratings

Model		D004	D007	D010	D016
Maximum Applicable Motor Output (HP) *2		1	2	3	5
Input	Rated Input Current (A)	6.0	8.9	12.0	18.1
	Rated Voltage Rated Frequency	Three-Phase 208 Vac 50/60 Hz			
	Allowable Voltage Fluctuation	-15 to 10%			
	Allowable Frequency Fluctuation	±5%			
Output	Rated Output Current (A)	4.6 *3	7.5 *3	10.6 *3	16.7 *3
	Minimum Applicable Motor Current (A)	1.5	1.5	1.5	3.75
	Overload Tolerance	110% of rated output current for 60 s 150% peak			
	Carrier Frequency	User adjustable between 1 and 12.5 kHz (Maximum Frequency varies with Rated Output Capacity)			
	Maximum Output Voltage (V)	Three-Phase 208 Vac			
	Maximum Output Frequency (Hz)	240 Hz			
Harmonics Reduction	Input Power (kVA)	Built-in			
EMC	Filter (IEC/EN 61800-3 Category 2)	Built-in			

*1 The maximum applicable motor output is based on 4-pole, general-purpose 220 V motor ratings. The rated output current of the drive output amps must be equal to or more than the motor rated current.

*2 The maximum applicable motor output complies with 208 V motor ratings as specified in NEC Table 430.250. The rated output current of the drive output amps must be equal to or more than the motor rated current.

*3 Carrier frequency is 5 kHz. You must derate the current to increase the carrier frequency.

Table 6.2 208 V Enclosed Ratings

Model		D024	D030	D046	D059	D074
Maximum Applicable Motor Output (HP) *2		7.5	10	15	20	25
Input	Rated Input Current (A)	25.6	32.2	48.6	61.8	77.2
	Rated Voltage Rated Frequency	Three-Phase 208 Vac 50/60 Hz				
	Allowable Voltage Fluctuation	-15 to 10%				
	Allowable Frequency Fluctuation	±5%				
Output	Rated Output Current (A)	24.2 *3	30.8 *3	46.2 *3	59.4 *3	74.8 *3
	Minimum Applicable Motor Current (A)	3.75	3.75	7.5	7.5	15
	Overload Tolerance	110% of rated output current for 60 s 150% peak				
	Carrier Frequency	User adjustable between 1 and 12.5 kHz (Maximum Frequency varies with Rated Output Capacity)				
	Maximum Output Voltage (V)	Three-Phase 208 Vac				
	Maximum Output Frequency (Hz)	240 Hz				

Model		D024	D030	D046	D059	D074
Harmonics Reduction	Input Power (kVA)	Built-in				
EMC	Filter (IEC/EN 61800-3 Category 2)	Built-in				

- *1 The maximum applicable motor output is based on 4-pole, general-purpose 220 V motor ratings. The rated output current of the drive output amps must be equal to or more than the motor rated current.
- *2 The maximum applicable motor output complies with 208 V motor ratings as specified in NEC Table 430.250. The rated output current of the drive output amps must be equal to or more than the motor rated current.
- *3 Carrier frequency is 5 kHz. You must derate the current to increase the carrier frequency.

Table 6.3 208 V Enclosed Ratings

Model		D088	D114	D143	D169	D211	D273
Maximum Applicable Motor Output (HP) *2		30	40	50	60	75	100
Input	Rated Input Current (A)	90.4	116.4	145.4	171.4	212.4	275.4
	Rated Voltage Rated Frequency	Three-Phase 208 Vac 50/60 Hz					
	Allowable Voltage Fluctuation	-15 to 10%					
	Allowable Frequency Fluctuation	±5%					
Output	Rated Output Current (A)	88 *3	114 *3	143 *3	169 *3	211 *3	273 *3
	Minimum Applicable Motor Current (A)	15	15	30	30	30	45
	Overload Tolerance	110% of rated output current for 60 s 150% peak					
	Carrier Frequency	User adjustable between 1 and 12.5 kHz (Maximum Frequency varies with Rated Output Capacity)					
	Maximum Output Voltage (V)	Three-Phase 208 Vac					
	Maximum Output Frequency (Hz)	240 Hz					
Harmonics Reduction	Input Power (kVA)	Built-in					
EMC	Filter (IEC/EN 61800-3 Category 2)	Built-in					

- *1 The maximum applicable motor output is based on 4-pole, general-purpose 220 V motor ratings. The rated output current of the drive output amps must be equal to or more than the motor rated current.
- *2 The maximum applicable motor output complies with 208 V motor ratings as specified in NEC Table 430.250. The rated output current of the drive output amps must be equal to or more than the motor rated current.
- *3 Carrier frequency is 5 kHz. You must derate the current to increase the carrier frequency.

◆ 240 V Enclosed Model Specifications

Table 6.4 240 V Enclosed Ratings

Model		A004	A006	A009	A015
Maximum Applicable Motor Output (HP) *2		1	2	3	5
Input	Rated Input Current (A)	5.5	8.1	10.9	16.5
	Rated Voltage Rated Frequency	Three-Phase 208 Vac 50/60 Hz			
	Allowable Voltage Fluctuation	-15 to 10%			
	Allowable Frequency Fluctuation	±5%			

6 Specifications

Model		A004	A006	A009	A015
Output	Rated Output Current (A)	4.2 *3	6.8 *3	9.6 *3	15.2 *3
	Minimum Applicable Motor Current (A)	1.5	1.5	1.5	3.75
	Overload Tolerance	110% of rated output current for 60 s 150% peak			
	Carrier Frequency	User adjustable between 1 and 12.5 kHz (Maximum Frequency varies with Rated Output Capacity)			
	Maximum Output Voltage (V)	Three-Phase 208 Vac			
	Maximum Output Frequency (Hz)	240 Hz			
Harmonics Reduction	Input Power (kVA)	Built-in			
EMC	Filter (IEC/EN 61800-3 Category 2)	Built-in			

- *1 The maximum applicable motor output is based on 4-pole, general-purpose 220 V motor ratings. The rated output current of the drive output amps must be equal to or more than the motor rated current.
- *2 The maximum applicable motor output complies with 208 V motor ratings as specified in NEC Table 430.250. The rated output current of the drive output amps must be equal to or more than the motor rated current.
- *3 Carrier frequency is 5 kHz. You must derate the current to increase the carrier frequency.

Table 6.5 240 V Enclosed Ratings

Model		A022	A028	A042	A054	A068	A080
Maximum Applicable Motor Output (HP) *2		7.5	10	15	20	25	30
Input	Rated Input Current (A)	23.3	29.3	44.1	56.1	70.1	82.1
	Rated Voltage Rated Frequency	Three-Phase 208 Vac 50/60 Hz					
	Allowable Voltage Fluctuation	-15 to 10%					
	Allowable Frequency Fluctuation	±5%					
Output	Rated Output Current (A)	22 *3	28 *3	42 *3	54 *3	68 *3	80 *3
	Minimum Applicable Motor Current (A)	3.75	3.75	7.5	7.5	15	15
	Overload Tolerance	110% of rated output current for 60 s 150% peak					
	Carrier Frequency	User adjustable between 1 and 12.5 kHz (Maximum Frequency varies with Rated Output Capacity)					
	Maximum Output Voltage (V)	Three-Phase 208 Vac					
	Maximum Output Frequency (Hz)	240 Hz					
Harmonics Reduction	Input Power (kVA)	Built-in					
EMC	Filter (IEC/EN 61800-3 Category 2)	Built-in					

- *1 The maximum applicable motor output is based on 4-pole, general-purpose 220 V motor ratings. The rated output current of the drive output amps must be equal to or more than the motor rated current.
- *2 The maximum applicable motor output complies with 208 V motor ratings as specified in NEC Table 430.250. The rated output current of the drive output amps must be equal to or more than the motor rated current.
- *3 Carrier frequency is 5 kHz. You must derate the current to increase the carrier frequency.

Table 6.6 240 V Enclosed Ratings

Model		A104	A130	A154	A192	A248
Maximum Applicable Motor Output (HP) *2		40	50	60	75	100
Input	Rated Input Current (A)	106.1	132.1	156.1	193.3	250.1
	Rated Voltage Rated Frequency	Three-Phase 208 Vac 50/60 Hz				
	Allowable Voltage Fluctuation	-15 to 10%				
	Allowable Frequency Fluctuation	±5%				
Output	Rated Output Current (A)	104 *3	130 *3	154 *3	192 *3	248 *3
	Minimum Applicable Motor Current (A)	15	30	30	30	45
	Overload Tolerance	110% of rated output current for 60 s 150% peak				
	Carrier Frequency	User adjustable between 1 and 12.5 kHz (Maximum Frequency varies with Rated Output Capacity)				
	Maximum Output Voltage (V)	Three-Phase 208 Vac				
	Maximum Output Frequency (Hz)	240 Hz				
Harmonics Reduction	Input Power (kVA)	Built-in				
EMC	Filter (IEC/EN 61800-3 Category 2)	Built-in				

- *1 The maximum applicable motor output is based on 4-pole, general-purpose 220 V motor ratings. The rated output current of the drive output amps must be equal to or more than the motor rated current.
- *2 The maximum applicable motor output complies with 208 V motor ratings as specified in NEC Table 430.250. The rated output current of the drive output amps must be equal to or more than the motor rated current.
- *3 Carrier frequency is 5 kHz. You must derate the current to increase the carrier frequency.

◆ 480 V Enclosed Model Specifications

Table 6.7 480 V Enclosed Ratings

Model		B002	B003	B004	B007	B011	B014
Maximum Applicable Motor Output (HP) *2		1	2	3	5	7.5	10
Input	Rated Input Current (A)	2.7	4.0	5.4	8.2	11.6	14.6
	Rated Voltage Rated Frequency	Three-Phase 480 Vac 50/60 Hz					
	Allowable Voltage Fluctuation	-15 to 10%					
	Allowable Frequency Fluctuation	±5%					
Output	Rated Output Current (A)	2.1 *3	3.4 *3	4.8 *3	7.6 *3	11.0 *3	14.0 *3
	Minimum Applicable Motor Current (A)	1.5	1.5	1.5	1.5	1.5	3.75
	Overload Tolerance	110% of rated output current for 60 s 150% peak					
	Carrier Frequency	User adjustable between 1 and 12.5 kHz (Maximum Frequency varies with Rated Output Capacity)					
	Maximum Output Voltage (V)	Three-Phase 480 Vac					
	Maximum Output Frequency (Hz)	240 Hz					
Harmonics Reduction	Input Power (kVA)	Built-in					
EMC	Filter (IEC/EN 61800-3 Category 2)	Built-in					

6 Specifications

- *1 The maximum applicable motor output is based on 4-pole, general-purpose 220 V motor ratings. The rated output current of the drive output amps must be equal to or more than the motor rated current.
- *2 The maximum applicable motor output complies with 208 V motor ratings as specified in NEC Table 430.250. The rated output current of the drive output amps must be equal to or more than the motor rated current.
- *3 Carrier frequency is 5 kHz. You must derate the current to increase the carrier frequency.

Table 6.8 480 V Enclosed Ratings

Model		B021	B027	B034	B040	B052	B065	B077
Maximum Applicable Motor Output (HP) *2		15	20	25	30	40	50	60
Input	Rated Input Current (A)	21.6	27.6	35.0	41.0	53.0	66.0	78.0
	Rated Voltage Rated Frequency	Three-Phase 480 Vac 50/60 Hz						
	Allowable Voltage Fluctuation	-15 to 10%						
	Allowable Frequency Fluctuation	±5%						
Output	Rated Output Current (A)	21.0 *3	27.0 *3	34.0 *3	40.0 *3	52.0 *3	65.0 *3	77.0 *3
	Minimum Applicable Motor Current (A)	3.75	3.75	7.5	7.5	7.5	7.5	15
	Overload Tolerance	110% of rated output current for 60 s 150% peak						
	Carrier Frequency	User adjustable between 1 and 12.5 kHz (Maximum Frequency varies with Rated Output Capacity)						
	Maximum Output Voltage (V)	Three-Phase 480 Vac						
	Maximum Output Frequency (Hz)	240 Hz						
Harmonics Reduction	Input Power (kVA)	Built-in						
EMC	Filter (IEC/EN 61800-3 Category 2)	Built-in						

- *1 The maximum applicable motor output is based on 4-pole, general-purpose 220 V motor ratings. The rated output current of the drive output amps must be equal to or more than the motor rated current.
- *2 The maximum applicable motor output complies with 208 V motor ratings as specified in NEC Table 430.250. The rated output current of the drive output amps must be equal to or more than the motor rated current.
- *3 Carrier frequency is 5 kHz. You must derate the current to increase the carrier frequency.

Table 6.9 480 V Enclosed Ratings

Model		B096	B124	B156	B180	B240	B302
Maximum Applicable Motor Output (HP) *2		75	100	125	150	200	250
Input	Rated Input Current (A)	97.0	125.0	157.0	180.6	241.0	303.0
	Rated Voltage Rated Frequency	Three-Phase 480 Vac 50/60 Hz					
	Allowable Voltage Fluctuation	-15 to 10%					
	Allowable Frequency Fluctuation	±5%					
Output	Rated Output Current (A)	96 *3	124 *3	156 *3	180 *3	240 *3	302 *3
	Minimum Applicable Motor Current (A)	15	15	30	30	30	45
	Overload Tolerance	110% of rated output current for 60 s 150% peak					
	Carrier Frequency	User adjustable between 1 and 12.5 kHz (Maximum Frequency varies with Rated Output Capacity)					
	Maximum Output Voltage (V)	Three-Phase 480 Vac					
	Maximum Output Frequency (Hz)	240 Hz					

Model		B096	B124	B156	B180	B240	B302
Harmonics Reduction	Input Power (kVA)	Built-in					
EMC	Filter (IEC/EN 61800-3 Category 2)	Built-in					

- *1 The maximum applicable motor output is based on 4-pole, general-purpose 220 V motor ratings. The rated output current of the drive output amps must be equal to or more than the motor rated current.
- *2 The maximum applicable motor output complies with 208 V motor ratings as specified in NEC Table 430.250. The rated output current of the drive output amps must be equal to or more than the motor rated current.
- *3 Carrier frequency is 5 kHz. You must derate the current to increase the carrier frequency.

◆ Common Bypass Specifications

Note:

To get the longest product life, install the bypass in an environment that meets the necessary specifications.

Table 6.10 Control Characteristics

Item	Specification
Control Method	V/f Control (V/f)
Frequency Control Range	0.01 Hz to 400 Hz
Frequency Accuracy (Temperature Fluctuation)	Digital inputs: Within $\pm 0.01\%$ of the maximum output frequency ($-10\text{ }^{\circ}\text{C}$ to $+40\text{ }^{\circ}\text{C}$ ($14\text{ }^{\circ}\text{F}$ to $104\text{ }^{\circ}\text{F}$)) Analog inputs: Within $\pm 0.4\%$ of the maximum output frequency ($25\text{ }^{\circ}\text{C} \pm 10\text{ }^{\circ}\text{C}$ ($77\text{ }^{\circ}\text{F} \pm 18\text{ }^{\circ}\text{F}$))
Frequency Setting Resolution	Digital inputs: 0.01 Hz Analog inputs: 1/2048 of the maximum output frequency (11-bit)
Output Frequency Resolution	0.001 Hz
Frequency Setting Signal	Main speed frequency reference: 0 VDC to 10 VDC (20 k Ω), 4 mA to 20 mA (250 Ω), 0 mA to 20 mA (250 Ω)
Starting Torque	140%/3 Hz
Speed Control Range	1:40
Accel/Decel Time	0.1 s to 6000.0 s The bypass can set two pairs of different acceleration and deceleration times.
V/f Characteristics	Select from 15 pre-defined V/f patterns, or a user-set V/f pattern.
Main Control Functions	Restart After Momentary Power Loss, Speed Search, Overtorque/Undertorque Detection, 8 Step Speed (max.), Accel/Decel Switch, S-curve Acceleration/Deceleration, Auto-Tuning (Rotational and Stationary), Cooling Fan ON/OFF Switch, Slip Compensation, Torque Compensation, Jump Frequency, Upper/Lower Limits for Frequency Reference, DC Injection Braking at Start and Stop, Overexcitation Braking, High Slip Braking, PID Control (with Sleep Function), Energy Saving Control, APOGEE FLN Communication (RS-485 4.8 or 9.6 kbps), BACnet Communication (RS-485 max. 76.8 kbps), MEMOBUS/Modbus Communication (RS-485 max. 115.2 kbps), Metasys N2 Communication (RS-485 9.6 kbps), Auto Restart, Application Presets, Overexcitation Deceleration, Overvoltage Suppression

Table 6.11 Protection Functions

Item	Specification
Motor Protection (Drive and Bypass Modes)	Electronic thermal overload protection
Momentary Overcurrent Protection (Drive Mode)	Bypass stops when the output current is more than 175% of the rated output current.
Overload Protection (Drive Mode)	Bypass stops when the output current is more than these overload tolerances: <ul style="list-style-type: none"> • 110% of the rated output current for 60 seconds • 140% of the rated output current for 2.5 seconds when the bypass output frequency is 3 Hz The permitted frequency of overload is one time each 10 minutes. Note: If output frequency < 6 Hz, the bypass can trigger the overload protection function when the output current is in the overload tolerance range.
Overvoltage Protection (Drive Mode)	208/240 V: Stops when the DC bus voltage is more than approximately 410 V 480 V: Stops when the DC bus voltage is more than approximately 820 V

6 Specifications

Item	Specification
Undervoltage Protection (Drive Mode)	208/240 V: Stops when the DC bus voltage decreases to less than approximately 190 V 480 V: <ul style="list-style-type: none"> Stops when the DC bus voltage decreases to less than approximately 350 V when you use an input voltage less than 400 V Stops when the DC bus voltage decreases to less than approximately 380 V when you use an input voltage less than 460 V Stops when the DC bus voltage decreases to less than approximately 440 V when you use an input voltage of 460 V or more
Brownout Protection (Drive and Bypass Modes)	-
Momentary Power Loss Ride-thru (Drive and Bypass Modes)	Immediately stops when power loss is 15 ms or longer. Will automatically restart after power is restored. (depending on parameter settings)
Heatsink Overheat Protection (Drive Mode)	The bypass stops when the thermistor detects an IGBT temperature more than approximately 100 °C (212 °F). The trip temperature level is different for different models.
Stall Prevention (Drive Mode)	Stall prevention is available during acceleration, deceleration, and during run.
Ground Fault Protection (Drive Mode)	Electronic circuit protection Note: This protection detects ground faults during run. The bypass will not provide protection when: <ul style="list-style-type: none"> There is a low-resistance ground fault for the motor cable or terminal block Energizing the bypass when there is a ground fault.
DC Bus Charge LED (Drive Mode)	Charge LED illuminates when DC bus voltage is more than 50 V.

Table 6.12 Environment

Item	Specification
Area of Use	Indoors
Ambient Temperature Setting	UL Type 1: -10 °C to +40 °C (14 °F to 104 °F) UL Type 12: -10 °C to +40 °C (14 °F to 104 °F) UL Type 3R: -10 °C to +40 °C (14 °F to 104 °F) <ul style="list-style-type: none"> Do not let the bypass freeze.
Humidity	95% RH or less Do not let condensation form on the bypass.
Storage Temperature	-20 °C to +70 °C (-40 °F to +158 °F) (short-term temperature during transportation)
Surrounding Area	Pollution degree 2 or less Install the bypass in an area without: <ul style="list-style-type: none"> Oil mist, corrosive or flammable gas, or dust Metal powder, oil, water, or other unwanted materials Radioactive materials or flammable materials, including wood Harmful gas or fluids Salt Direct sunlight
Altitude	1000 m (3281 ft) maximum Note: Derate the output current by 1% for each 100 m (328 ft) to install the bypass in altitudes between 1000 m to 4000 m (3281 ft to 13123 ft). It is not necessary to derate the rated voltage in these conditions: <ul style="list-style-type: none"> When you install the bypass at 2000 m (6562 ft) or lower When you install the bypass between 2000 m to 4000 m (6562 ft to 13123 ft) and ground the neutral point on the power supply.
Vibration	<ul style="list-style-type: none"> 10 Hz to 20 Hz: 1 G (9.8 m/s², 32.15 ft/s²) 20 Hz to 55 Hz: F6B1D004 to D030, F6B1A004 to A028, F6B1B002 to B034: 0.6 G (5.9 m/s², 19.36 ft/s²) F6B1D046 to D273, F6B1A042 to A248, F6B1B040 to B302: 0.2 G (1.96 m/s², 6.43 ft/s²)
Installation Orientation	Install the bypass vertically for sufficient airflow to cool the bypass.

Table 6.13 Certifications and Standard Compliance

Item	Specification
c-UL-us	UL 508A
Seismic Certification	<ul style="list-style-type: none"> CBC, IBC, ASCE7, ICC-ES 156 HCAI (Special Seismic Certification Preapproval OSP-0687)

Table 6.14 Enclosure Ratings

Item	Specification
Protection Design	UL Type 1 UL Type 12 UL Type 3R

◆ Drive Watt Loss

■ 208 V Models

Table 6.15 Drive Watt Loss (NEMA Rating)

Bypass Model	Drive Model	Rated Output Current A	Carrier Frequency kHz	Interior Unit Loss W	Cooling Fin Loss W	Total Loss W
D004 to D010	2011	10.6	5.0	45	86	131
D016	2017	16.7	5.0	56	140	196
D024	2024	24.2	5.0	75	184	259
D030	2031	30.8	5.0	89	244	333
D046	2046	46.2	5.0	116	314	430
D059	2059	59.4	5.0	148	418	566
D074	2075	74.8	5.0	175	538	713
D088	2088	88	5.0	201	615	816
D114	2114	114	5.0	246	780	1026
D143	2143	143	5.0	244	937	1180
D169	2169	169	5.0	279	1132	1411
D211	2211	211	5.0	331	1321	1651
D273	2273	273	5.0	423	1821	2244

■ 240 V Models

Table 6.16 Drive Watt Loss (NEMA Rating)

Bypass Model	Drive Model	Rated Output Current A	Carrier Frequency kHz	Interior Unit Loss W	Cooling Fin Loss W	Total Loss W
A004 to A009	2011	10.6	5.0	45	86	131
A015	2017	16.7	5.0	56	140	196
A022	2024	24.2	5.0	75	184	259
A028	2031	30.8	5.0	89	244	333
A042	2046	46.2	5.0	116	314	430
A054	2059	59.4	5.0	148	418	566
A068	2075	74.8	5.0	175	538	713
A080	2088	88	5.0	201	615	816
A104	2114	114	5.0	246	780	1026
A130	2143	143	5.0	244	937	1180
A154	2169	169	5.0	279	1132	1411
A192	2211	211	5.0	331	1321	1651
A248	2273	273	5.0	423	1821	2244

■ 480 V Models

Table 6.17 Drive Watt Loss (NEMA Rating)

Bypass Model	Drive Model	Rated Output Current A	Carrier Frequency kHz	Interior Unit Loss W	Cooling Fin Loss W	Total Loss W
B002 to B004	4005	4.8	5.0	36	39	75
B007	4008	7.6	5.0	45	63	108
B011	4011	11	5.0	56	142	198
B014	4014	14	5.0	66	196	262
B021	4021	21	5.0	89	212	301
B027	4027	27	5.0	112	285	397
B034	4034	34	5.0	128	327	455
B040	4040	40	5.0	145	373	518
B052	4052	52	5.0	178	470	648
B065	4065	65	5.0	224	600	824
B077	4077	77	5.0	271	819	1090
B096	4096	96	5.0	323	973	1295
B124	4124	124	5.0	423	1294	1717
B156	4156	156	5.0	332	1448	1780
B180	4180	180	5.0	395	1707	2102
B240	4240	240	5.0	406	1810	2216
B302	4302	302	5.0	866	2847	3712

◆ Peripheral Devices and Options

■ Bypass Communication Options

There are many available peripheral devices and options for the bypass.

Refer to the FP605 Selection Guide (SG.FP605.01) for information about available options, including:

- Main circuit options
- Frequency settings and monitor options
- Keypad options
- Attachment options
- Engineering tools

Contact Yaskawa or your nearest sales representative to make an order.

Refer to the instruction manual for each option for wiring information.

■ Tools Required for Option Installation

- A Phillips screwdriver (M3 metric or #1, #2 U.S. standard) to install the option and remove the bypass front cover. Screw sizes vary by capacity. Select a screwdriver appropriate for the capacity.
- A straight-edge screwdriver (blade depth: 0.4 mm, width: 2.5 mm) to wire the option terminal block when installing the SI-W3 LonWorks option.

Note:

This manual does not list the tools required to prepare the option cables for wiring.

■ Bypass Communication Options

These communication options are available for the bypass:

Option D

Ethernet/IP dual-port communication option.

Option G

DeviceNet communication option.

Option H

PROFIBUS-DP communication option.

Option L

Serial Communication, Echelon LonWorks: An isolated circuit board provides LonTalk protocol for network communication to a BAS.

Option Q

Modbus TCP/IP dual port communication option.

■ Option Installation Procedure

Before You Install the Option

NOTICE *Install communications options on the bypass control PCB. Do not install communications options on the drive PCB. Improperly connected communications options will cause erroneous operation.*

Verify Bypass Operation

Verify that the bypass functions normally without the option installed. Refer to *Electrical Installation* for information on wiring and connecting the bypass.

Prepare Network Cables for SI-W3 LonWorks Options

Use only LonWorks network cables.

Refer to the Echelon website for more information on network cabling (www.echelon.com). The performance cannot be guaranteed if you use non-LonWorks network cables.

Separate the LonWorks cables from the wiring to the main circuit and other lines.

Determine the length of cable required to connect from the option to a network device and attach all connectors to network cables.

The communication terminal is a pluggable terminal block that serves as the connection point of the LonWorks network cable to the option.

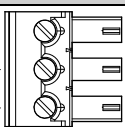
Terminal	Terminal No.	Name	Description
1 	1	A	Signal Line A
2	2	SLD	Shield
3	3	B	Signal Line B

NOTICE *Heat shrink tubing or electrical tape may be required to ensure that cable shielding does not touch contact with other wiring. Insufficient insulation may cause a short circuit that can damage the option or the bypass.*

Note:

- Use shielded wires and shielded twisted-pair wires. If the grounding is not correct, electrical interference can cause the drive or devices around it to malfunction.
- Do not use wiring that is longer than 50 m (164 ft) to supply the frequency reference with an analog signal from a remote source. Wiring that is too long can cause unsatisfactory system performance.

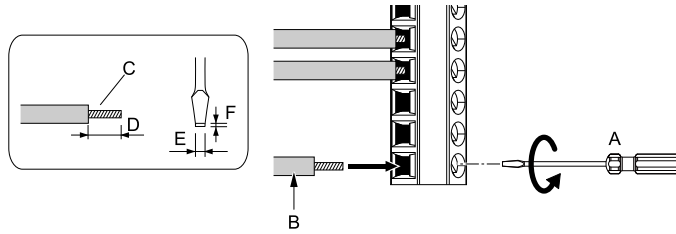

- A - Loosen the screws and put the wire into the opening on the terminal block.
- B - Wire with a crimp ferrule attached, or use wire that is not soldered with the core wires lightly twisted.
- C - Pull back the shielding and lightly twist the end with your fingers to keep the ends from fraying.
- D - If you do not use crimp ferrules, remove approximately 5.5 mm (0.21 in) of the covering at the end of the wire.
- E - Blade width of 2.5 mm (0.1 in) or less
- F - Blade depth of 0.4 mm (0.01 in) or less

⚠ WARNING Fire Hazard. Tighten all terminal screws to the correct tightening torque. Connections that are too loose or too tight can cause incorrect operation and damage to the bypass. Incorrect connections can also cause death or serious injury from fire.

NOTICE Do not tin stranded wire with solder. Soldered wire connections can become loose over time and cause unsatisfactory system performance.

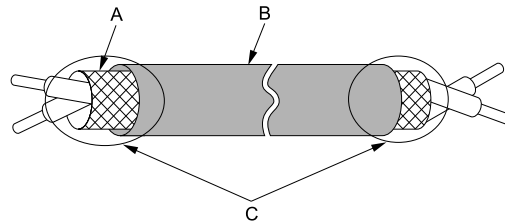

- A - Shield
- B - Sheath
- C - Insulate with electrical tape or shrink tubing.

Figure 6.1 Prepare the Ends of Shielded Wire

Prepare Network Cables for Ethernet-based Options

Determine the length of cable required to connect from the option to a network device and attach all connectors to network cables before you install the option.

The Ethernet-based option options will have either one or two RJ45 ports available for connection(s). The mating RJ45 modular connector and cable are customer-supplied

Table 6.18 8-Way Modular Connector (Customer-Supplied)

Male 8-Way Modular Connector	Pin	Description
	1 (Pair 2)	Transmit data (TXD) +
	2 (Pair 2)	Transmit data (TXD) -
	3 (Pair 3)	Receive data (RXD) +
	4 (Pair 1)	Not used for 10 Mbps and 100 Mbps networks
	5 (Pair 1)	Not used for 10 Mbps and 100 Mbps networks
	6 (Pair 3)	Receive data (RXD) -
	7 (Pair 4)	Not used for 10 Mbps and 100 Mbps networks
	8 (Pair 4)	Not used for 10 Mbps and 100 Mbps networks

Communication Protocol	Description
EtherNet/IP	Only use cable recommended for EtherNet/Industrial Protocol (EtherNet/IP™). Using a cable not specifically recommended may cause the option or bypass to malfunction. Refer to the ODVA website for more information on network cabling (www.odva.org).
Modbus TCP/IP	Only use cable recommended for Modbus TCP/IP. Using a cable not specifically recommended may cause the option or bypass to malfunction. Refer to the Modbus-IDA website for more information on network cabling (www.modbus.org).

Communication Protocol	Description
PROFINET	Only use cable recommended for PROFINET. Using a cable not specifically recommended may cause the option or bypass to malfunction. Refer to the PROFIBUS and PROFINET International (PI) website for more information (www.profibus.com).
BACnet/IP	Only use shielded Cat5e cable or better. Using a cable not specifically recommended may cause the option or bypass to malfunction.

Install the Option

1. De-energize the system at the power source. Observe correct lockout/tagout safety procedures and wait for the CHARGE light to completely go out on the drive. The CHARGE light will be visible when you open the cabinet door.
2. Open the cabinet door to access Bypass PCB A2.
3. Install the option to port CN5 on the Bypass PCB A2.
4. Use the two screws included in the option kit to fasten the option card to the metal standoffs on Bypass PCB A2. Tighten each screw to 0.5 to 0.6 N•m (4.4 to 5.3 in lbs).

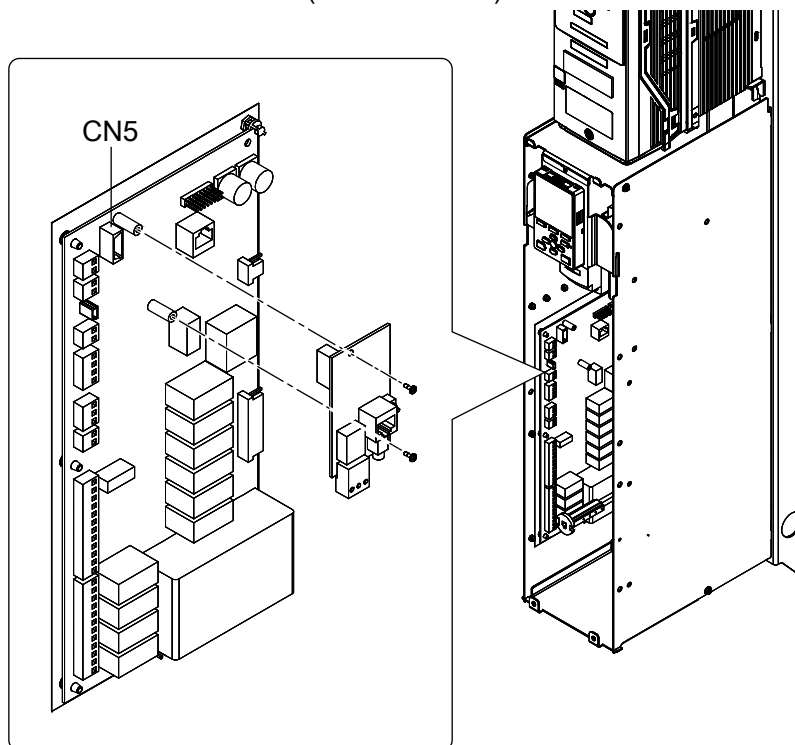

Figure 6.2 Insert Option into Bypass PCB CN5 Connector Port

5. Firmly insert the end of the customer-supplied network cable into the CN1 connection port on the option board. When you have a dual-port option, connect two network cables to the two RJ45 ports. Acceptable connection topologies are different for different options. Refer to the option instructions for more information.

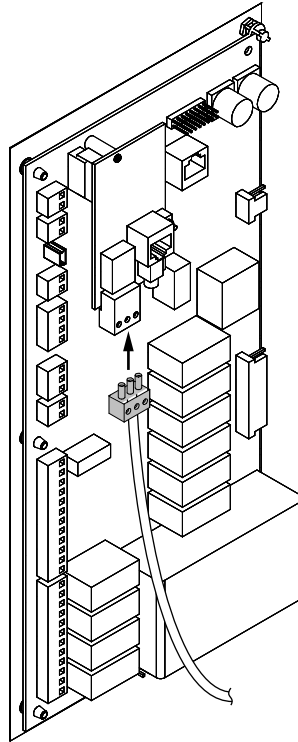

Figure 6.3 Connect Network Cable to Option (SI-W3 LonWorks Example)

NOTICE Separate the communication wiring from the input power, motor, and 120 Vac control wiring. Electrical interference can cause communication data errors.

6. Make sure that you did not pinch cables between the front cover and the bypass enclosure, then replace and secure the front cover.
7. Set the bypass parameters for option functionality. Refer to the option manual for your communication protocol for programming information.

◆ Periodic Inspection and Maintenance

For detailed information about:

- Recommended inspections
- Replacement of parts, including the keypad battery
- Drive cooling fan and circulation fan replacement procedures
- Storage guidelines

Refer to the FP605 Bypass Technical Reference (SIEPYAIFP601).

7 Parameter List

◆ How to Read the Parameter List

■ Terms that Identify Parameters

Icon	Description
Hex.	Hexadecimal numbers that represent MEMOBUS addresses to change parameters over network communication.
RUN	You can change the parameter setting during Run.
Expert	The parameter is available in Expert Mode only. <i>*/</i>

*1 Set A1-01 = 3 [Access Level Selection = Expert Level] to show and set Expert Mode parameters on the keypad.

◆ A: Initialization Parameters

■ A1: Initialization

No. (Hex.)	Name	Description
A1-00 (0100) RUN	Language Selection	Sets the language for the HOA keypad. 0 : English 5 : Espanol
A1-01 (0101) RUN	Access Level Selection	Sets user access to parameters. The access level controls which parameters the keypad will display and which parameters you can set. 0 : Operation Only 1 : User Parameters 2 : Advanced Level 3 : Expert Level 4 : Lock Parameters
A1-03 (0103)	Initialize Parameters	Sets parameters to default values. 0 : No Initialization 1110 : User Initialization 2220 : 2-Wire Initialization 9990 : EEPROM Initialization
A1-04 (0104)	Password	Entry point for the password set in A1-05 [Password Setting]. The user can view the settings of parameters that are locked without entering the password. Enter the correct password in this parameter to change parameter settings.
A1-05 (0105)	Password Setting	Sets a password to lock parameters and prevent changes to parameter settings. Enter the correct password in A1-04 [Password] to unlock parameters and accept changes.
A1-11 (111D) Expert	Firmware Update Lock	Protects the drive firmware. When you enable the protection, you cannot update the bypass controller firmware. 0 : Disabled 1 : Enabled
A1-12 (1564)	Bluetooth ID	Sets the password necessary to use Bluetooth to control the drive with a smartphone or tablet.

■ A2: User Parameters

No. (Hex.)	Name	Description
A2-01 (0106)	User Parameter 1	Sets the parameter number to be shown for number 1 of the [User Custom Parameters] under the main menu. You can select a maximum of 32 parameters for the drive and set them to parameters A2-01 to A2-32.
A2-02 (0107)	User Parameter 2	Sets the parameter number to be shown for number 2 of the [User Custom Parameters] under the main menu. You can select a maximum of 32 parameters for the drive and set them to parameters A2-01 to A2-32.
A2-03 (0108)	User Parameter 3	Sets the parameter number to be shown for number 3 of the [User Custom Parameters] under the main menu. You can select a maximum of 32 parameters for the drive and set them to parameters A2-01 to A2-32.
A2-04 (0109)	User Parameter 4	Sets the parameter number to be shown for number 4 of the [User Custom Parameters] under the main menu. You can select a maximum of 32 parameters for the drive and set them to parameters A2-01 to A2-32.
A2-05 (010A)	User Parameter 5	Sets the parameter number to be shown for number 5 of the [User Custom Parameters] under the main menu. You can select a maximum of 32 parameters for the drive and set them to parameters A2-01 to A2-32.
A2-06 (010B)	User Parameter 6	Sets the parameter number to be shown for number 6 of the [User Custom Parameters] under the main menu. You can select a maximum of 32 parameters for the drive and set them to parameters A2-01 to A2-32.
A2-07 (010C)	User Parameter 7	Sets the parameter number to be shown for number 7 of the [User Custom Parameters] under the main menu. You can select a maximum of 32 parameters for the drive and set them to parameters A2-01 to A2-32.
A2-08 (010D)	User Parameter 8	Sets the parameter number to be shown for number 8 of the [User Custom Parameters] under the main menu. You can select a maximum of 32 parameters for the drive and set them to parameters A2-01 to A2-32.
A2-09 (010E)	User Parameter 9	Sets the parameter number to be shown for number 9 of the [User Custom Parameters] under the main menu. You can select a maximum of 32 parameters for the drive and set them to parameters A2-01 to A2-32.
A2-10 (010F)	User Parameter 10	Sets the parameter number to be shown for number 10 of the [User Custom Parameters] under the main menu. You can select a maximum of 32 parameters for the drive and set them to parameters A2-01 to A2-32.
A2-11 (0110)	User Parameter 11	Sets the parameter number to be shown for number 11 of the [User Custom Parameters] under the main menu. You can select a maximum of 32 parameters for the drive and set them to parameters A2-01 to A2-32.

◆ b: Application

■ b1: Operation Mode Selection

No. (Hex.)	Name	Description
b1-01 (0180)	Frequency Reference Selection 1	Sets the input method for the frequency reference. 0 : Keypad 1 : Analog Input 2 : Serial Communications 3 : Option PCB
b1-02 (0181)	Run Command Selection 1	Sets the input method for the Run command. 0 : Keypad 1 : Digital Input 2 : Serial Communications 3 : Option PCB
b1-03 (0182)	Stopping Method Selection	Sets the method to stop the motor after removing a Run command or entering a Stop command. 0 : Ramp to Stop 1 : Coast to Stop 2 : DC Injection Braking to Stop 3 : Coast to Stop with Timer
b1-04 (0183)	Reverse Operation Selection	Sets the reverse operation function. Disable reverse operation in fan or pump applications where reverse rotation is dangerous. 0 : Reverse Enabled 1 : Reverse Disabled
b1-08 (0187)	Run Command Select in PRG Mode	Sets the conditions for the drive to accept a Run command entered from an external source when using the keypad to set parameters. 0 : Disregard RUN while Programming 1 : Accept RUN while Programming 2 : Allow Programming Only at Stop
b1-11 (01DF)	Run Delay @ Stop	Sets the amount of time that the drive will not accept the Run command again after the Run command is lost.
b1-12 (01E0)	Run Delay Memory Selection	Sets how the drive saves the Run Delay Timer to the EEPROM during power loss. 0 : Disabled 1 : Only at Stop 2 : Running & Stop
b1-17 (01C6)	Run Command at Power Up	Sets drive response when you apply power to drive that has an external Run command. Set this parameter in applications where energizing or de-energizing the drive enables the Run command. 0 : Disregard Existing RUN Command 1 : Accept Existing RUN Command
b1-40 (3BCF)	Deceleration Abort Time	Sets the maximum time until the drive shuts off the output to decelerate to stop.

■ b2: DC Inj/Short Ckt Braking

No. (Hex.)	Name	Description
b2-01 (0189)	DC Injection/Zero SpeedThreshold	Sets the frequency to start DC Injection Braking.
b2-02 (018A)	DC Injection Braking Current	Sets the DC Injection Braking current as a percentage of the drive rated current.
b2-03 (018B)	DC Inject Braking Time at Start	Sets the DC Injection Braking Time at stop.
b2-04 (018C)	DC Inject Braking Time at Stop	Sets the DC Injection Braking Time at stop.
b2-09 (01E1)	Pre-heat Current 2	Sets the percentage of motor rated output current used for the motor pre-heat function.

■ b3: Speed Search

No. (Hex.)	Name	Description
b3-01 (0191)	Speed Search at Start Selection	Sets the Speed Search at Start function where the drive will do Speed Search with each Run command. 0 : Disabled 1 : Enabled
b3-02 (0192)	SpeedSearch Deactivation Current	Sets the current level that stops Speed Search as a percentage of the drive rated output current. Usually it is not necessary to change this setting.
b3-03 (0193)	Speed Search Deceleration Time	Sets the deceleration time during Speed Search operation. Set the length of time to decelerate from the maximum output frequency to the minimum output frequency.
b3-04 (0194)	V/f Gain during Speed Search	Sets the ratio used to reduce the V/f during searches to reduce the output current during speed searches.
b3-05 (0195)	Speed Search Delay Time	Sets the Speed Search delay time to activate a magnetic contactor installed between the drive and motor.
b3-06 (0196) Expert	Speed Estimation Current Level 1	Sets the level of current that flows to the motor during Speed Estimation Speed Search as a coefficient of the motor rated current. Usually it is not necessary to change this setting.
b3-07 (0197) Expert	Speed Estimation Current Level 2	Sets the level of current that flows to the motor during Speed Estimation Speed Search as a coefficient of <i>E2-03 [Motor No-Load Current]</i> . Usually it is not necessary to change this setting.
b3-08 (0198)	Speed Estimation ACR P Gain	Sets the proportional gain for the automatic current regulator during Speed Estimation Speed Search. Also adjusts speed search responsiveness. Usually it is not necessary to change this setting.
b3-09 (0199)	Speed Estimation ACR I Time	Sets the integral time for the automatic current regulator during Speed Estimation Speed Search. Also adjusts speed search responsiveness. Usually it is not necessary to change this setting.
b3-10 (019A) Expert	Speed Estimation Detection Gain	Sets the gain to correct estimated frequencies from Speed Estimation Speed Search.
b3-11 (019B) Expert	Spd Est Method Switch-over Level	Uses the quantity of voltage in the motor to automatically switch the search method within the type of speed measurement.
b3-12 (019C) Expert	Speed Search Current Deadband	Sets the minimum current detection level during Speed Search. If the drive does not do Speed Estimation, increase this setting in 0.1-unit increments.
b3-14 (019E)	Bi-directional Speed Search	Sets the direction of Speed Search to the direction of the frequency reference or in the motor rotation direction as detected by the drive. 0 : Disabled 1 : Enabled
b3-17 (01F0) Expert	Speed Est Retry Current Level	Sets the current level for the search retry function in Speed Estimation Speed Search as a percentage where drive rated current is a setting value of 100%.
b3-18 (01F1) Expert	Speed Est Retry Detection Time	Sets the length of time that the drive will wait to retry Speed Estimation Speed Search when too much current flow stopped the Speed Search.
b3-19 (01F2)	Speed Search Restart Attempts	Sets the number of times to restart Speed Search if Speed Search does not complete.
b3-24 (01C0)	Speed Search Method Selection	Sets the Speed Search method when you start the motor or when you return power after a momentary power loss. 1 : Speed Estimation 2 : Current Detection 2
b3-25 (01C8) Expert	Speed Search Wait Time	Sets the length of time the drive will wait to start the Speed Search Retry function.
b3-26 (01C7) Expert	Direction Determination Level	Sets the level to find the motor rotation direction. Increase the value if the drive cannot find the direction.
b3-27 (01C9) Expert	Speed Search RUN/BB Priority	Sets the conditions necessary to start Speed Search. 0 : SS Only if RUN Applied Before BB 1 : SS Regardless of RUN/BB Sequence

No. (Hex.)	Name	Description
b3-31 (0BC0) Expert	Spd Search Current Reference Lvl	Sets the current level that decreases the output current during Current Detection Speed Search.
b3-32 (0BC1) Expert	Spd Search Current Complete Lvl	Sets the current level that completes Speed Search.
b3-39 (1B8F) Expert	Regen Judgement LV of Spd Search	Regen Judgement LV of Spd Search.
b3-56 (3126)	InverseRotationSearch WaitTime	Sets the wait time until the drive starts inverse rotation search after it completes forward search when you do inverse rotation search during Current Detection Speed Search.

■ b4: Timer Function

No. (Hex.)	Name	Description
b4-01 (01A3)	Timer Function ON-Delay Time	Sets the ON-delay time for the timer input.
b4-02 (01A4)	Timer Function OFF-Delay Time	Sets the OFF-delay time for the timer input.
b4-03 (0B30) Expert	Terminal M1-M2 ON-Delay Time	Sets the delay time to activate the contact after the function set in <i>H2-01</i> activates.
b4-04 (0B31) Expert	Terminal M1-M2 OFF-Delay Time	Sets the delay time to deactivate the contact after the function set in <i>H2-01</i> deactivates.
b4-05 (0B32) Expert	Terminal M3-M4 ON-Delay Time	Sets the delay time to activate the contact after the function set in <i>H2-02</i> activates.
b4-06 (0B33) Expert	Terminal M3-M4 OFF-Delay Time	Sets the delay time to deactivate the contact after the function set in <i>H2-02</i> deactivates.
b4-07 (0B34) Expert	Terminal MD-ME-MF ON-Delay Time	Sets the delay time to activate the contact after the function set in <i>H2-03</i> activates.
b4-08 (0B35) Expert	Terminal MD-ME-MF OFF-Delay Time	Sets the delay time to deactivate the contact after the function set in <i>H2-03</i> deactivates.

■ b5: PID Control

No. (Hex.)	Name	Description
b5-01 (01A5)	PID Mode Setting	Sets the type of PID control. 0 : Disabled 1 : Standard
b5-02 (01A6) RUN	Proportional Gain (P)	Sets the proportional gain (P) that is applied to PID input.
b5-03 (01A7) RUN	Integral Time (I)	Sets the integral time (I) that is applied to PID input.
b5-04 (01A8) RUN	Integral Limit	Sets the upper limit for integral control (I) as a percentage of the Maximum Output Frequency.
b5-05 (01A9) RUN	Derivative Time (D)	Sets the derivative time (D) for PID control. This parameter adjusts system responsiveness.

7 Parameter List

No. (Hex.)	Name	Description
b5-06 (01AA) RUN	PID Output Limit	Sets the maximum possible output from the PID controller as a percentage of the Maximum Output Frequency.
b5-07 (01AB) RUN	PID Offset Adjustment	Sets the offset for the PID control output as a percentage of the Maximum Output Frequency.
b5-08 (01AC) RUN Expert	PID Primary Delay Time Constant	Sets the primary delay time constant for the PID control output. Usually it is not necessary to change this setting.
b5-09 (01AD)	PID Output Level Selection	Sets the polarity of the PID output. 0 : Normal Output (Direct Acting) 1 : Reverse Output (Reverse Acting)
b5-10 (01AE) RUN	PID Output Gain Setting	Sets the amount of gain to apply to the PID output.
b5-11 (01AF)	PID Output Reverse Selection	Sets the function that enables and disables reverse motor rotation for negative PID control output. 0 : Lower Limit is Zero 1 : Negative Output Accepted
b5-17 (01B5) RUN	PID Accel/Decel Time	Raises or lowers the PID setpoint using the acceleration and deceleration times set to the drive. This is a soft-starter for the PID setpoint.
b5-18 (01DC)	PID Setpoint Selection	Sets the function that enables and disables YA-01 to YA-04 [Setpoint 1 to Setpoint 4]. 0 : Disabled 1 : Enabled
b5-28 (01EA)	PID Feedback Square Root Sel	Enables and disables the square root of the PID Feedback compared to the PID Setpoint to set an appropriate drive output for the correct system regulation. 0 : Disabled 1 : Enabled
b5-29 (01EB)	PID Feedback Square Root Gain	Sets the multiplier applied to the square root of the feedback.
b5-30 (01EC)	PID Feedback Offset	Sets PID feedback Offset as a percentage of maximum frequency.
b5-34 (019F) RUN	PID Output Lower Limit Level	Sets the output lower limit for the PID control as a percentage of the Maximum Output Frequency.
b5-35 (01A0) RUN	PID Input Limit Level	Sets the output upper limit for the PID control as a percentage of the Maximum Output Frequency.
b5-38 (01FE)	PID User Unit Display Scaling	Sets the value that the drive sets or shows as the PID setpoint when at the maximum output frequency.
b5-39 (01FF)	PID User Unit Display Digits	Sets the number of digits to set and show the PID setpoint. 0 : No Decimal Places (XXXXX) 1 : One Decimal Places (XXXX.X) 2 : Two Decimal Places (XXX.XX) 3 : Three Decimal Places (XX.XXX)

No. (Hex.)	Name	Description
b5-41 (0160)	PID Output 2 Unit	Sets the display units in U5-14 [PID Out2 Upr4 Digits] and U5-15 [PID Out2 Lwr4 Digits]. 0 : "WC: inches of water column 1 : PSI: pounds per square inch 2 : GPM: gallons/min 3 : °F: Fahrenheit 4 : ft³/min: cubic feet/min 5 : m³/h: cubic meters/hour 6 : L/h: liters/hour 7 : L/s: liters/sec 8 : bar: bar 9 : Pa: Pascal 10 : °C: Celsius 11 : m: meters 12 : ft: feet 13 : L/min: liters/min 14 : m³/min: cubic meters/min 15 : "Hg: Inch Mercury 16 : kPa: kilopascal 48 : %: Percent 49 : Custom(b5-68~70) 50 : None
b5-42 (0161) RUN	PID Output 2 Calc Mode	Sets how to calculate the original PID output. 0 : Linear 1 : Square Root 2 : Quadratic 3 : Cubic
b5-43 (0162) RUN	PID Out2 Monitor MAX Upper4 Dig	Sets the upper 4 digits of the maximum monitor value. Used with b5-44 [PID Out2 Monitor MAX Lower4 Dig] to set maximum monitor value of U5-14 [PID Out2 Upr4 Digits] and U5-15 [PID Out2 Lwr4 Digits] at maximum frequency.
b5-44 (0163) RUN	PID Out2 Monitor MAX Lower4 Dig	Sets the lower 4 digits of the maximum monitor value. Used with b5-43 [PID Out2 Monitor MAX Upper4 Dig] to set maximum monitor value of U5-14 [PID Out2 Upr4 Digits] and U5-15 [PID Out2 Lwr4 Digits] at maximum frequency.
b5-45 (0164) RUN	PID Out2 Monitor MIN for Linear	Sets the minimum display value to show when at zero speed. Only effective when b5-42 = 0 [PID Output 2 Calc Mode = Linear].
b5-46 (0165)	PID Unit Display Selection	Sets the units-text for the PID Display. 0 : "WC: inches of water column 1 : PSI: pounds per square inch 2 : GPM: gallons/min 3 : °F: Fahrenheit 4 : ft³/min: cubic feet/min 5 : m³/h: cubic meters/hour 6 : L/h: liters/hour 7 : L/s: liters/sec 8 : bar: bar 9 : Pa: Pascal 10 : °C: Celsius 11 : m: meters 12 : ft: feet 13 : L/min: liters/min 14 : m³/min: cubic meters/min 15 : "Hg: Inch Mercury 16 : kPa: kilopascal 48 : %: Percent 49 : Custom(b5-68~70) 50 : None
b5-53 (0B8F) RUN	PID Integrator Ramp Limit	Sets the responsiveness of PID control when the PID feedback changes quickly.
b5-68 (3C1F)	System Unit Custom Character 1	Sets the first character of the custom unit display when b5-46 = 49 [PID Unit Display Selection = Custom (B5-68~70)].

7 Parameter List

No. (Hex.)	Name	Description
b5-69 (3C20)	System Unit Custom Character 2	Sets the second character of the custom unit display when $b5-46 = 49$ [PID Unit Display Selection = Custom (B5-68~70)].
b5-70 (3C21)	System Unit Custom Character 3	Sets the third character of the custom unit display when $b5-46 = 49$ [PID Unit Display Selection = Custom (B5-68~70)].
b5-71 (3C22)	Min PID Transducer Scaling	Sets the minimum PID level corresponding to the lowest analog input signal level.
b5-82 (31B0)	Feedback Loss 4 ~ 20mA Detect Sel	Sets the drive to do a 4 to 20 mA wire-break detection on the analog input set for PID feedback. 0 : Disabled 1 : Alarm Only 2 : Fault 3 : Run At b5-83
b5-83 (31B1) RUN	Feedback Loss GoTo Frequency	Sets the speed at which the drive will run if the drive detects a 4 to 20 mA wire-break on the PID Feedback and $b5-82 = 3$ [Feedback Loss 4 ~ 20mA Detect Sel = Run At b5-83].
b5-84 (31B2) RUN	Feedback Loss Loss Of Prime Lvl	Sets the level at which the drive will detect Loss of Prime in the pump.
b5-85 (31B3) RUN	Feedback Loss GoTo Freq Timeout	When $b5-82 = 3$ [Feedback Loss 4 ~ 20mA Detect Sel = Run At b5-83] and the Feedback signal is lost, the drive will run at the $b5-83$ [Feedback Loss Goto Frequency] speed for this length of time, after which the drive will fault on <i>FDBKL</i> [WIRE Break].
b5-86 (31B4) RUN	Feedback Loss Start Delay	When you initiate an AUTO Run command, the drive will wait for this length of time before it will fault on <i>FDBKL</i> [WIRE Break] or use parameter $b5-83$ [Feedback Loss Goto Frequency].

■ b6: Dwell Function

No. (Hex.)	Name	Description
b6-01 (01B6)	Dwell Reference at Start	Sets the output frequency that the drive will hold momentarily when the motor starts.
b6-02 (01B7)	Dwell Time at Start	Sets the length of time that the drive will hold the output frequency when the motor starts.
b6-03 (01B8)	Dwell Reference at Stop	Sets the output frequency that the drive will hold momentarily when ramping to stop the motor.
b6-04 (01B9)	Dwell Time at Stop	Sets the length of time for the drive to hold the output frequency when ramping to stop the motor.

■ b8: Energy Saving

No. (Hex.)	Name	Description
b8-01 (01CC)	Energy Saving Control Selection	Sets the Energy-saving control function. 0 : Disabled 1 : Enabled
b8-04 (01CF) Expert	Energy Saving Coefficient Value	Sets the Energy-saving control coefficient to maintain maximum motor efficiency. The default setting is for Yaskawa motors.
b8-05 (01D0) Expert	Power Detection Filter Time	Sets the time constant to measure output power.
b8-06 (01D1) Expert	Search Operation Voltage Limit	Sets the voltage limit for Search Operation as a percentage of the motor rated voltage.

◆ C: Tuning

■ C1: Accel & Decel Time

No. (Hex.)	Name	Description
C1-01 (0200) RUN	Acceleration Time 1	Sets the length of time to accelerate from zero to maximum output frequency.
C1-02 (0201) RUN	Deceleration Time 1	Sets the length of time to decelerate from maximum output frequency to zero.
C1-03 (0202) RUN	Acceleration Time 2	Sets the length of time to accelerate from zero to maximum output frequency.
C1-04 (0203) RUN	Deceleration Time 2	Sets the length of time to decelerate from maximum output frequency to zero.
C1-09 (0208) RUN	Fast Stop Time	Sets the length of time that the drive will decelerate to zero for a Fast Stop.

■ C2: S-Curve Characteristics

No. (Hex.)	Name	Description
C2-01 (020B)	S-Curve Time @ Start of Accel	Sets the S-curve acceleration time at start.
C2-02 (020C)	S-Curve Time @ End of Accel	Sets the S-curve acceleration time at completion.
C2-03 (020D)	S-Curve Time @ Start of Decel	Sets the S-curve deceleration time at start.
C2-04 (020E)	S-Curve Time @ End of Decel	Sets the S-curve deceleration time at completion.

■ C3: Slip Compensation

No. (Hex.)	Name	Description
C3-01 (020F) RUN Expert	Slip Compensation Gain	Sets the gain for the slip compensation function. Usually it is not necessary to change this setting.
C3-02 (0210) RUN Expert	Slip Compensation Delay Time	Sets the slip compensation delay time when speed is unstable or when the slip compensation response is too slow. Usually it is not necessary to change this setting.
C3-03 (0211) Expert	Slip Compensation Limit	Sets the upper limit for the slip compensation function as a percentage of the motor rated slip.
C3-04 (0212) Expert	Slip Compensation at Regen	Sets the slip compensation function during regenerative operation. 0 : Disabled 1 : Enabled Above 6Hz

■ C4: Torque Compensation

No. (Hex.)	Name	Description
C4-01 (0215) RUN	Torque Compensation Gain	Sets the gain for the torque compensation function. Use this parameter value for motor 1 when you operate multiple motors.
C4-02 (0216) RUN	Torque Compensation Delay Time	Sets the torque compensation delay time. Usually it is not necessary to change this setting.

■ C6: Carrier Frequency

No. (Hex.)	Name	Description
C6-02 (0224)	Carrier Frequency Selection	Sets the carrier frequency for the transistors in the drive. 1 : 2.0 kHz 2 : 5.0 kHz 3 : 8.0 kHz 4 : 10.0 kHz 5 : 12.5 kHz 7 : Swing PWM1 (Audible Sound 1) 8 : Swing PWM2 (Audible Sound 2) 9 : Swing PWM3 (Audible Sound 3) A : Swing PWM4 (Audible Sound 4) B : Leakage Current Rejection PWM F : User Defined (C6-03 to C6-05)
C6-03 (0225)	Carrier Frequency Upper Limit	Sets the upper limit of the carrier frequency. Set $C6-02 = F$ [Carrier Frequency Selection = User Defined (C6-03 to C6-05)] to set this parameter.
C6-04 (0226)	Carrier Frequency Lower Limit	Sets the lower limit of the carrier frequency. Set $C6-02 = F$ [Carrier Frequency Selection = User Defined (C6-03 to C6-05)] to set this parameter.
C6-05 (0227)	Carrier Freq Proportional Gain	Sets the proportional gain for the carrier frequency. Set $C6-02 = F$ [Carrier Frequency Selection = User Defined (C6-03 to C6-05)] to set this parameter.

◆ d: Reference Settings

■ d1: Frequency Reference

No. (Hex.)	Name	Description
d1-01 (0280) RUN	Reference 1	Sets the frequency reference in the units from <i>o1-03</i> [Frequency Display Unit Selection].
d1-02 (0281) RUN	Reference 2	Sets the frequency reference in the units from <i>o1-03</i> [Frequency Display Unit Selection].
d1-03 (0282) RUN	Reference 3	Sets the frequency reference in the units from <i>o1-03</i> [Frequency Display Unit Selection].
d1-04 (0283) RUN	Reference 4	Sets the frequency reference in the units from <i>o1-03</i> [Frequency Display Unit Selection].
d1-05 (0284) RUN	Reference 5	Sets the frequency reference in the units from <i>o1-03</i> [Frequency Display Unit Selection].
d1-06 (0285) RUN	Reference 6	Sets the frequency reference in the units from <i>o1-03</i> [Frequency Display Unit Selection].
d1-07 (0286) RUN	Reference 7	Sets the frequency reference in the units from <i>o1-03</i> [Frequency Display Unit Selection].

No. (Hex.)	Name	Description
d1-08 (0287) RUN	Reference 8	Sets the frequency reference in the units from o1-03 [Frequency Display Unit Selection].
d1-09 (0288)	Reference 9	Sets the frequency reference in the units from o1-03 [Frequency Display Unit Selection].
d1-10 (028B)	Reference 10	Sets the frequency reference in the units from o1-03 [Frequency Display Unit Selection].
d1-11 (028C)	Reference 11	Sets the frequency reference in the units from o1-03 [Frequency Display Unit Selection].
d1-12 (028D)	Reference 12	Sets the frequency reference in the units from o1-03 [Frequency Display Unit Selection].
d1-13 (028E)	Reference 13	Sets the frequency reference in the units from o1-03 [Frequency Display Unit Selection].
d1-14 (028F)	Reference 14	Sets the frequency reference in the units from o1-03 [Frequency Display Unit Selection].
d1-15 (0290)	Reference 15	Sets the frequency reference in the units from o1-03 [Frequency Display Unit Selection].
d1-16 (0291)	Reference 16	Sets the frequency reference in the units from o1-03 [Frequency Display Unit Selection].
d1-17 (0292) RUN	Jog Reference	Sets the Jog frequency reference in the units from o1-03 [Frequency Display Unit Selection]. Set H1-xx = 6 [MFDI Function Selection = Jog Reference Selection] to use the Jog frequency reference.

■ d2: Reference Limits

No. (Hex.)	Name	Description
d2-01 (0289)	Frequency Reference Upper Limit	Sets maximum limit for all frequency references. The maximum output frequency is 100%.
d2-02 (028A)	Frequency Reference Lower Limit	Sets minimum limit for all frequency references. The maximum output frequency is 100%.
d2-03 (0293)	Analog Frequency Ref Lower Limit	Sets the lower limit for the master frequency reference (the first frequency of the multi-step speed reference) as a percentage. The maximum output frequency is 100%.

■ d3: Jump Frequency

No. (Hex.)	Name	Description
d3-01 (0294)	Jump Frequency 1	Sets the median value of the frequency band that the drive will avoid.
d3-02 (0295)	Jump Frequency 2	Sets the median value of the frequency band that the drive will avoid.
d3-03 (0296)	Jump Frequency 3	Sets the median value of the frequency band that the drive will avoid.
d3-04 (0297)	Jump Frequency Width	Sets the width of the frequency band that the drive will avoid.

■ d4: Frequency Ref Up/Down Hold

No. (Hex.)	Name	Description
d4-01 (0298)	Freq Reference Hold Selection	Sets the function that saves the frequency reference after a Stop command or when de-energizing the drive. 0 : Disabled 1 : Enabled

■ d6: Field Weakening

No. (Hex.)	Name	Description
d6-01 (02A0)	Field Weakening Level	Sets the drive output voltage as a percentage of E1-05 [Maximum Output Voltage] when H1-xx = 63 [Field Weakening] is activated.
d6-02 (02A1)	Field Weakening Frequency Limit	Sets the minimum output frequency to start field weakening.

■ d7: Offset Frequency

No. (Hex.)	Name	Description
d7-01 (02B2) RUN	Offset Frequency 1	Uses H1-xx = 44 [MFDI Function Select = Add Offset Frequency 1 (d7-01)] as a percentage of the Maximum Output Frequency to add or subtract the set frequency to/from the frequency reference.
d7-02 (02B3) RUN	Offset Frequency 2	Uses H1-xx = 45 [MFDI Function Select = Add Offset Frequency 2 (d7-02)] as a percentage of the Maximum Output Frequency to add or subtract the set frequency to/from the frequency reference.
d7-03 (02B4) RUN	Offset Frequency 3	Uses H1-xx = 46 [MFDI Function Select = Add Offset Frequency 3 (d7-03)] as a percentage of the Maximum Output Frequency to add or subtract the set frequency to/from the frequency reference.

◆ E: Motor Parameters

■ E1: V/f Pattern for Motor 1

No. (Hex.)	Name	Description
E1-01 (0300)	Input AC Supply Voltage	Sets the drive input voltage.
E1-03 (0302)	V/f Pattern Selection	Sets the V/f pattern for the drive and motor. You can use one of the preset patterns or you can make a custom pattern. 0 : Const Trq, 50Hz base, 50Hz max 1 : Const Trq, 60Hz base, 60Hz max 2 : Const Trq, 50Hz base, 60Hz max 3 : Const Trq, 60Hz base, 72Hz max 4 : VT, 50Hz, 65% Vmid reduction 5 : VT, 50Hz, 50% Vmid reduction 6 : VT, 60 Hz, 65% Vmid reduction 7 : VT, 60Hz, 50% Vmid reduction 8 : High Trq, 50Hz, 25% Vmin boost 9 : High Trq, 50Hz, 65% Vmin boost A : High Trq, 60Hz, 25% Vmin boost B : High Trq, 60Hz, 65% Vmin boost C : High Freq, 60Hz base, 90Hz max D : High Freq, 60Hz base, 120Hz max E : High Freq, 60Hz base, 180Hz max F : Custom
E1-04 (0303)	Maximum Output Frequency	Sets the maximum output frequency for the V/f pattern.
E1-05 (0304)	Maximum Output Voltage	Sets the maximum output voltage for the V/f pattern.
E1-06 (0305)	Base Frequency	Sets the base frequency for the V/f pattern.
E1-07 (0306)	Mid Point A Frequency	Sets a middle output frequency for the V/f pattern.
E1-08 (0307)	Mid Point A Voltage	Sets a middle output voltage for the V/f pattern.
E1-09 (0308)	Minimum Output Frequency	Sets the minimum output frequency for the V/f pattern.

No. (Hex.)	Name	Description
E1-10 (0309)	Minimum Output Voltage	Sets the minimum output voltage for the V/f pattern.
E1-11 (030A) Expert	Mid Point B Frequency	Sets a middle output frequency for the V/f pattern.
E1-12 (030B) Expert	Mid Point B Voltage	Sets a middle point voltage for the V/f pattern.
E1-13 (030C) Expert	Base Voltage	Sets the base voltage for the V/f pattern.

■ E2: Motor Parameters

No. (Hex.)	Name	Description
E2-01 (030E)	Motor Rated Current (FLA)	Sets the motor rated current in amps.
E2-02 (030F)	Motor Rated Slip	Sets motor rated slip.
E2-03 (0310)	Motor No-Load Current	Sets the no-load current for the motor in amps when operating at the rated frequency and the no-load voltage.
E2-04 (0311)	Motor Pole Count	Sets the number of motor poles.
E2-05 (0312)	Motor Line-to-Line Resistance	Sets the line-to-line resistance for the motor stator windings.
E2-06 (0313)	Motor Leakage Inductance	Sets the voltage drop from motor leakage inductance when the motor is operating at the rated frequency and rated current. This value is a percentage of Motor Rated Voltage.
E2-10 (0317)	Motor Iron Loss	Sets the motor iron loss.
E2-11 (0318)	Motor Rated Power	Sets the motor rated output in the units from 01-58 [Motor Power Unit Selection].

◆ F: Options

■ F4: Analog Output Option

No. (Hex.)	Name	Description
F4-01 (0391)	Terminal V1 Function Selection	Sets the monitor signal output from terminal V1.
F4-02 (0392) RUN	Terminal V1 Gain	Sets the gain of the monitor signal that is sent from terminal V1. Sets the analog signal output level from the terminal V1 at 10 V or 20 mA as 100% when an output for monitoring items is 100%.
F4-03 (0393)	Terminal V2 Function Selection	Sets the monitor signal output from terminal V2.
F4-04 (0394) RUN	Terminal V2 Gain	Sets the gain of the monitor signal that is sent from terminal V2. Sets the analog signal output level from terminal V2 at 10 V or 20 mA as 100% when an output for monitoring items is 100%.
F4-05 (0395) RUN	Terminal V1 Bias	Sets the bias of the monitor signal that is sent from terminal V1. When an output for monitoring items is 0%, this parameter sets the analog signal output level from the V1 terminal as a percentage of 10 V.
F4-06 (0396) RUN	Terminal V2 Bias	Sets the bias of the monitor signal that is sent from terminal V2. Set the level of the analog signal sent from the V2 terminal at 10 V or 20 mA as 100% when an output for monitoring items is 0%.

7 Parameter List

No. (Hex.)	Name	Description
F4-07 (0397)	Terminal V1 Signal Level	Sets the output signal level for terminal V1. 0 : 0 to 10 V 1 : -10 to 10 V
F4-08 (0398)	Terminal V2 Signal Level	Sets the output signal level for terminal V2. 0 : 0 to 10 V 1 : -10 to 10 V

■ F5: Digital Output Option

No. (Hex.)	Name	Description
F5-01 (0399)	Terminal P1-PC Function Select	Sets the function of terminal P1-PC on the DO-A3 option. Set <i>F5-09 = 2 [DO-A3 Output Mode Selection = Programmable (F5-01 to F5-08)]</i> to enable this function.
F5-02 (039A)	Terminal P2-PC Function Select	Sets the function of terminal P2-PC on the DO-A3 option. Set <i>F5-09 = 2 [DO-A3 Output Mode Selection = Programmable (F5-01 to F5-08)]</i> to enable this function.
F5-03 (039B)	Terminal P3-PC Function Select	Sets the function of terminal P3-PC on the DO-A3 option. Set <i>F5-09 = 2 [DO-A3 Output Mode Selection = Programmable (F5-01 to F5-08)]</i> to enable this function.
F5-04 (039C)	Terminal P4-PC Function Select	Sets the function of terminal P4-PC on the DO-A3 option. Set <i>F5-09 = 2 [DO-A3 Output Mode Selection = Programmable (F5-01 to F5-08)]</i> to enable this function.
F5-05 (039D)	Terminal P5-PC Function Select	Sets the function of terminal P5-PC on the DO-A3 option. Set <i>F5-09 = 2 [DO-A3 Output Mode Selection = Programmable (F5-01 to F5-08)]</i> to enable this function.
F5-06 (039E)	Terminal P6-PC Function Select	Sets the function of terminal P6-PC on the DO-A3 option. Set <i>F5-09 = 2 [DO-A3 Output Mode Selection = Programmable (F5-01 to F5-08)]</i> to enable this function.
F5-07 (039F)	Terminal M1-M2 Function Select	Sets the function of terminal M1-M2 on the DO-A3 option. Set <i>F5-09 = 2 [DO-A3 Output Mode Selection = Programmable (F5-01 to F5-08)]</i> to enable this function.
F5-08 (03A0)	Terminal M3-M4 Function Select	Sets the function of terminal M3-M4 on the DO-A3 option. Set <i>F5-09 = 2 [DO-A3 Output Mode Selection = Programmable (F5-01 to F5-08)]</i> to enable this function.
F5-09 (03A1)	DO-A3 Output Mode Selection	Sets the output mode of signals from the DO-A3 option. 0 : Predefined Individual Outputs 1 : Binary Output 2 : Programmable (F5-01 to F5-08)

■ F6: Communication Options

No. (Hex.)	Name	Description
F6-01 (03A2)	Communication Error Selection	Sets the method to stop the motor or let the motor continue operating when the drive detects <i>bUS [Option Communication Error]</i> . 0 : Ramp to Stop 1 : Coast to Stop 2 : Fast Stop (Use C1-09) 3 : Alarm Only 4 : Alarm (Run at d1-04) 5 : Alarm - Ramp Stop
F6-02 (03A3)	Comm External Fault (EF0) Detect	Sets the conditions at which <i>EF0 [Option Card External Fault]</i> is detected. 0 : Always Detected 1 : Detected during RUN Only
F6-03 (03A4)	Comm External Fault (EF0) Select	Sets the method to stop the motor or let the motor continue operating when the drive detects an <i>EF0 [Option Card External Fault]</i> . 0 : Ramp to Stop 1 : Coast to Stop 2 : Fast Stop (Use C1-09) 3 : Alarm Only
F6-04 (03A5)	bUS Error Detection Time	Sets the delay time for the drive to detect <i>bUS [Option Communication Error]</i> .
F6-07 (03A8)	Multi-Step Ref @ NetRef/ComRef	Sets the function that enables and disables the multi-step speed reference when the frequency reference source is NetRef or ComRef (communication option card or MEMOBUS/Modbus communications). 0 : Disable Multi-Step References 1 : Enable Multi-Step References

No. (Hex.)	Name	Description
F6-08 (036A)	Comm Parameter Reset @Initialize	Sets the function to initialize <i>F6-xx</i> and <i>F7-xx</i> parameters when the drive is initialized with <i>A1-03</i> [Initialize Parameters]. 0 : No Reset - Parameters Retained 1 : Reset Back to Factory Default
F6-14 (03BB)	BUS Error Auto Reset	Sets the automatic reset function for <i>bUS</i> [Option Communication Errors]. 0 : Disabled 1 : Enabled
F6-15 (0B5B)	Comm. Option Parameters Reload	Sets the update method when you change <i>F6-xx</i> , <i>F7-xx</i> [Communication Options]. 0 : Reload at Next Power Cycle 1 : Reload Now 2 : Cancel Reload Request
F6-30 (03CB)	PROFIBUS-DP Node Address	Sets the node address for PROFIBUS-DP communication. Restart the drive after you change the parameter setting.
F6-31 (03CC)	PROFIBUS-DP Clear Mode Selection	Sets what the drive will do after it receives the Clear Mode command. 0 : Reset 1 : Hold Previous State
F6-32 (03CD)	PROFIBUS-DP Data Format Select	Sets the data format of PROFIBUS-DP communication. Restart the drive after you change the parameter setting. 0 : PPO Type 1 : Conventional 2 : PPO (bit0) 3 : PPO Type (Enter) 4 : Conventional (Enter) 5 : PPO (bit0, Enter)
F6-48 (02FE)	BACnet Device Object Identifier 0	Sets the Instance Identifier of the BACnet Device Object, where the <i>F6-48</i> value is the least significant word.
F6-49 (02FF)	BACnet Device Object Identifier 1	Sets the Instance Identifier of the BACnet Device Object, where the <i>F6-49</i> value is the most significant word.
F6-50 (03C1)	DeviceNet MAC Address	Sets the MAC address for DeviceNet communication. Restart the drive after you change the parameter setting.
F6-51 (03C2)	DeviceNet Baud Rate	Sets the DeviceNet communications speed. Restart the drive after you change the parameter setting. 0 : 125 kbps 1 : 250 kbps 2 : 500 kbps 3 : Adjustable from Network 4 : Detect Automatically
F6-52 (03C3)	DeviceNet PCA Setting	Sets the format of data that the DeviceNet communication master sends to the drive.
F6-53 (03C4)	DeviceNet PPA Setting	Sets the format of data that the drive sends to the DeviceNet communication master.
F6-54 (03C5)	Net Idle Fault Detection	Sets the function to detect <i>EF0</i> [Option Card External Fault] when the drive does not receive data from the DeviceNet or EtherNet/IP master. 0 : Enabled 1 : Disabled, No Fault Detection 2 : Vendor Specific 3 : RUN Forward 4 : RUN Reverse
F6-55 (03C6)	DeviceNet Baud Rate Monitor	Sets the function to see the actual DeviceNet communications speed using the keypad. This parameter functions as a monitor only. 0 : 125 kbps 1 : 250 kbps 2 : 500 kbps
F6-56 (03D7)	DeviceNet Speed Scaling	Sets the speed scale for DeviceNet communication.
F6-57 (03D8)	DeviceNet Current Scaling	Sets the current scale of the DeviceNet communication master.
F6-58 (03D9)	DeviceNet Torque Scaling	Sets the torque scale of the DeviceNet communication master.
F6-59 (03DA)	DeviceNet Power Scaling	Sets the power scale of the DeviceNet communication master.

7 Parameter List

No. (Hex.)	Name	Description
F6-60 (03DB)	DeviceNet Voltage Scaling	Sets the voltage scale of the DeviceNet communication master.
F6-61 (03DC)	DeviceNet Time Scaling	Sets the time scale of the DeviceNet communication master.
F6-62 (03DD)	DeviceNet Heartbeat Interval	Sets the heartbeat for DeviceNet communication. Set this parameter to 0 to disable the heartbeat function.
F6-63 (03DE)	DeviceNet Network MAC ID	Sets the function to see the actual DeviceNet MAC address using the keypad. This parameter functions as a monitor only.
F6-64 (03DF)	Dynamic Out Assembly 109 Param1	Sets Configurable Output 1 written to the MEMOBUS register.
F6-65 (03E0)	Dynamic Out Assembly 109 Param2	Sets Configurable Output 2 written to the MEMOBUS register.
F6-66 (03E1)	Dynamic Out Assembly 109 Param3	Sets Configurable Output 3 written to the MEMOBUS register.
F6-67 (03E2)	Dynamic Out Assembly 109 Param4	Sets Configurable Output 4 written to the MEMOBUS register.
F6-68 (03E3)	Dynamic In Assembly 159 Param 1	Sets Configurable Input 1 read from the MEMOBUS register.
F6-69 (03E4)	Dynamic In Assembly 159 Param 2	Sets Configurable Input 2 read from the MEMOBUS register.
F6-70 (03C7)	Dynamic In Assembly 159 Param 3	Sets Configurable Input 3 read from the MEMOBUS register.
F6-71 (03C8)	Dynamic In Assembly 159 Param 4	Sets Configurable Input 4 read from the MEMOBUS register.

■ F7: Ethernet Options

Note:

You must cycle power or set $F6-15 = 1$ [*Comm. Option Parameters Reload = Reload Now*] for F7-xx parameters to take effect.

No. (Hex.)	Name	Description
F7-01 (03E5)	IP Address 1	Sets the first octet of the IP Address for the device that is connecting to the network. Restart the drive after you change this parameter.
F7-02 (03E6)	IP Address 2	Sets the second octet of the IP Address for the device that is connecting to the network. Restart the drive after you change this parameter.
F7-03 (03E7)	IP Address 3	Sets the third octet of the IP Address for the device that is connecting to the network. Restart the drive after you change this parameter.
F7-04 (03E8)	IP Address 4	Sets the fourth octet of the IP Address for the device that is connecting to the network. Restart the drive after you change this parameter.
F7-05 (03E9)	Subnet Mask 1	Sets the first octet of the subnet mask of the connected network.
F7-06 (03EA)	Subnet Mask 2	Sets the second octet of the subnet mask of the connected network.
F7-07 (03EB)	Subnet Mask 3	Sets the third octet of the subnet mask of the connected network.
F7-08 (03EC)	Subnet Mask 4	Sets the fourth octet of the subnet mask of the connected network.
F7-09 (03ED)	Gateway Address 1	Sets the first octet of the gateway address of the connected network.
F7-10 (03EE)	Gateway Address 2	Sets the second octet of the gateway address of the connected network.
F7-11 (03EF)	Gateway Address 3	Sets the third octet of the gateway address of the connected network.

No. (Hex.)	Name	Description
F7-12 (03F0)	Gateway Address 4	Sets the fourth octet of the gateway address of the connected network.
F7-13 (03F1)	Address Mode at Startup	Sets the method to set option card IP addresses. 0 : Static 1 : BOOTP 2 : DHCP
F7-14 (03F2)	Duplex Mode Selection	Sets the duplex mode setting method. 0 : Half/Half 1 : Auto/Auto 2 : Full/Full 3 : Half/Auto 4 : Half/Full 5 : Auto/Half 6 : Auto/Full 7 : Full/Half 8 : Full/Auto
F7-15 (03F3)	Communication Speed Selection	Sets the communications speed. 10 : 10/10 Mbps 100 : 100/100 Mbps 101 : 10/100 Mbps 102 : 100/10 Mbps
F7-16 (03F4)	Timeout Value	Sets the detection time for a communications timeout.
F7-17 (03F5)	EtherNet/IP Speed Scaling Factor	Sets the scaling factor for the speed monitor in the EtherNet/IP Class ID 2AH Object.
F7-18 (03F6)	EtherNet/IP Current Scale Factor	Sets the scaling factor for the output current monitor in the EtherNet/IP Class ID 2AH Object.
F7-19 (03F7)	EtherNet/IP Torque Scale Factor	Sets the scaling factor for the torque monitor in the EtherNet/IP Class ID 2AH Object.
F7-20 (03F8)	EtherNet/IP Power Scaling Factor	Sets the scaling factor for the power monitor in the EtherNet/IP Class ID 2AH Object.
F7-21 (03F9)	EtherNet/IP Voltage Scale Factor	Sets the scaling factor for the voltage monitor in the EtherNet/IP Class ID 2AH Object.
F7-22 (03FA)	EtherNet/IP Time Scaling	Sets the scaling factor for the time monitor in the EtherNet/IP Class ID 2AH Object.
F7-23 (03FB)	Dynamic Out Param 1 for CommCard	Sets Output Assembly 116 when you use an Ethernet/IP option. The drive writes the values from Output Assembly 116 to the MEMOBUS/Modbus address register that is stored for each parameter. The drive will not write the values from Output Assembly 116 to the registers when the MEMOBUS/Modbus address is 0. When you use a ProfiNet option, set this parameter to set to configurable output 1.
F7-24 (03FC)	Dynamic Out Param 2 for CommCard	Sets Output Assembly 116 when you use an Ethernet/IP option. The drive writes the values from Output Assembly 116 to the MEMOBUS/Modbus address register that is stored for each parameter. The drive will not write the values from Output Assembly 116 to the registers when the MEMOBUS/Modbus address is 0. When you use a ProfiNet option, set this parameter to set to configurable output 2.
F7-25 (03FD)	Dynamic Out Param 3 for CommCard	Sets Output Assembly 116 when you use an Ethernet/IP option. The drive writes the values from Output Assembly 116 to the MEMOBUS/Modbus address register that is stored for each parameter. The drive will not write the values from Output Assembly 116 to the registers when the MEMOBUS/Modbus address is 0. When you use a ProfiNet option, set this parameter to set to configurable output 3.
F7-26 (03FE)	Dynamic Out Param 4 for CommCard	Sets Output Assembly 116 when you use an Ethernet/IP option. The drive writes the values from Output Assembly 116 to the MEMOBUS/Modbus address register that is stored for each parameter. The drive will not write the values from Output Assembly 116 to the registers when the MEMOBUS/Modbus address is 0. When you use a ProfiNet option, set this parameter to set to configurable output 4.
F7-27 (03FF)	Dynamic Out Param 5 for CommCard	Sets Output Assembly 116 when you use an Ethernet/IP option. The drive writes the values from Output Assembly 116 to the MEMOBUS/Modbus address register that is stored for each parameter. The drive will not write the values from Output Assembly 116 to the registers when the MEMOBUS/Modbus address is 0. When you use a ProfiNet option, set this parameter to set to configurable output 5.
F7-28 (0370)	Dynamic Out Param 6 for CommCard	Sets Output Assembly 116 when you use an Ethernet/IP option. The drive writes the values from Output Assembly 116 to the MEMOBUS/Modbus address register that is stored for each parameter. The drive will not write the values from Output Assembly 116 to the registers when the MEMOBUS/Modbus address is 0.
F7-29 (0371)	Dynamic Out Param 7 for CommCard	Sets Output Assembly 116 when you use an Ethernet/IP option. The drive writes the values from Output Assembly 116 to the MEMOBUS/Modbus address register that is stored for each parameter. The drive will not write the values from Output Assembly 116 to the registers when the MEMOBUS/Modbus address is 0.
F7-30 (0372)	Dynamic Out Param 8 for CommCard	Sets Output Assembly 116 when you use an Ethernet/IP option. The drive writes the values from Output Assembly 116 to the MEMOBUS/Modbus address register that is stored for each parameter. The drive will not write the values from Output Assembly 116 to the registers when the MEMOBUS/Modbus address is 0.

7 Parameter List

No. (Hex.)	Name	Description
F7-31 (0373)	Dynamic Out Param 9 for CommCard	Sets Output Assembly 116 when you use an Ethernet/IP option. The drive writes the values from Output Assembly 116 to the MEMOBUS/Modbus address register that is stored for each parameter. The drive will not write the values from Output Assembly 116 to the registers when the MEMOBUS/Modbus address is 0.
F7-32 (0374)	Dynamic Out Param 10 for CommCard	Sets Output Assembly 116 when you use an Ethernet/IP option. The drive writes the values from Output Assembly 116 to the MEMOBUS/Modbus address register that is stored for each parameter. The drive will not write the values from Output Assembly 116 to the registers when the MEMOBUS/Modbus address is 0.
F7-33 (0375)	Dynamic In Param 1 for CommCard	Sets Input Assembly 166 when you use an Ethernet/IP option. The drive sends the values from the MEMOBUS/Modbus address registers stored for each parameter to Input Assembly 166. The drive returns the default register value for the option card when the MEMOBUS/Modbus address is 0 and the value sent to Input Assembly 166 is not defined. When you use a ProfiNet option, set this parameter to set to configurable input 1.
F7-34 (0376)	Dynamic In Param 2 for CommCard	Sets Input Assembly 166 when you use an Ethernet/IP option. The drive sends the values from the MEMOBUS/Modbus address registers stored for each parameter to Input Assembly 166. The drive returns the default register value for the option card when the MEMOBUS/Modbus address is 0 and the value sent to Input Assembly 166 is not defined. When you use a ProfiNet option, set this parameter to set to configurable input 2.
F7-35 (0377)	Dynamic In Param 3 for CommCard	Sets Input Assembly 166 when you use an Ethernet/IP option. The drive sends the values from the MEMOBUS/Modbus address registers stored for each parameter to Input Assembly 166. The drive returns the default register value for the option card when the MEMOBUS/Modbus address is 0 and the value sent to Input Assembly 166 is not defined. When you use a ProfiNet option, set this parameter to set to configurable input 3.
F7-36 (0378)	Dynamic In Param 4 for CommCard	Sets Input Assembly 166 when you use an Ethernet/IP option. The drive sends the values from the MEMOBUS/Modbus address registers stored for each parameter to Input Assembly 166. The drive returns the default register value for the option card when the MEMOBUS/Modbus address is 0 and the value sent to Input Assembly 166 is not defined. When you use a ProfiNet option, set this parameter to set to configurable input 4.
F7-37 (0379)	Dynamic In Param 5 for CommCard	Sets Input Assembly 166 when you use an Ethernet/IP option. The drive sends the values from the MEMOBUS/Modbus address registers stored for each parameter to Input Assembly 166. The drive returns the default register value for the option card when the MEMOBUS/Modbus address is 0 and the value sent to Input Assembly 166 is not defined. When you use a ProfiNet option, set this parameter to set to configurable input 5.
F7-38 (037A)	Dynamic In Param 6 for CommCard	Sets Input Assembly 166 when you use an Ethernet/IP option. The drive sends the values from the MEMOBUS/Modbus address registers stored for each parameter to Input Assembly 166. The drive returns the default register value for the option card when the MEMOBUS/Modbus address is 0 and the value sent to Input Assembly 166 is not defined.
F7-39 (037B)	Dynamic In Param 7 for CommCard	Sets Input Assembly 166 when you use an Ethernet/IP option. The drive sends the values from the MEMOBUS/Modbus address registers stored for each parameter to Input Assembly 166. The drive returns the default register value for the option card when the MEMOBUS/Modbus address is 0 and the value sent to Input Assembly 166 is not defined.
F7-40 (037C)	Dynamic In Param 8 for CommCard	Sets Input Assembly 166 when you use an Ethernet/IP option. The drive sends the values from the MEMOBUS/Modbus address registers stored for each parameter to Input Assembly 166. The drive returns the default register value for the option card when the MEMOBUS/Modbus address is 0 and the value sent to Input Assembly 166 is not defined.
F7-41 (037D)	Dynamic In Param 9 for CommCard	Sets Input Assembly 166 when you use an Ethernet/IP option. The drive sends the values from the MEMOBUS/Modbus address registers stored for each parameter to Input Assembly 166. The drive returns the default register value for the option card when the MEMOBUS/Modbus address is 0 and the value sent to Input Assembly 166 is not defined.
F7-42 (037E)	Dynamic In Param 10 for CommCard	Sets Input Assembly 166 when you use an Ethernet/IP option. The drive sends the values from the MEMOBUS/Modbus address registers stored for each parameter to Input Assembly 166. The drive returns the default register value for the option card when the MEMOBUS/Modbus address is 0 and the value sent to Input Assembly 166 is not defined.
F7-50 (1BC1)	BACnet/IP Port	Sets the UDP port on which the drive will receive incoming BACnet messages.
F7-51 (1BE9)	BBMD Foreign Register Addr 1	Sets the first octet of the IP Address of the BACnet Broadcast Management Device (BBMD) to which the drive will register as a foreign device.
F7-52 (1BEA)	BBMD Foreign Register Addr 2	Sets the second octet of the IP Address of the BACnet Broadcast Management Device (BBMD) to which the drive will register as a foreign device.
F7-53 (1BEB)	BBMD Foreign Register Addr 3	Sets the third octet of the IP Address of the BACnet Broadcast Management Device (BBMD) to which the drive will register as a foreign device.
F7-54 (1BEC)	BBMD Foreign Register Addr 4	Sets the fourth octet of the IP Address of the BACnet Broadcast Management Device (BBMD) to which the drive will register as a foreign device. .
F7-55 (1BED)	BBMD Foreign Register Port	Sets the UDP port of the BBMD device to which the drive will register.
F7-56 (1BEE)	BBMD Foreign Register Time	Sets the time interval in which the drive will repeat BBMD foreign registration.
F7-57 (1BEF)	BACnet/IP BUS Timeout Value	Sets the length of time that the drive will wait after it receives a Run command or frequency reference command before it detects a <i>bUS</i> fault.
F7-60 (0780)	PZD1 Write (Control Word)	When you use a Profibus option, set the MEMOBUS/Modbus address for PZD1 (PPO output). PZD1 (PPO output) functions as the STW when <i>F7-60 = 0 to 2</i> .
F7-61 (0781)	PZD2 Write (Frequency Reference)	When you use a Profibus option, sets the MEMOBUS/Modbus address for PZD2 (PPO output). PZD2 (PPO output) functions as the HSW when <i>F7-61 = 0 to 2</i> .
F7-62 (0782)	PZD3 Write	When you use a Profibus option, sets the MEMOBUS/Modbus address for PZD3 (PPO output). A value of 0, 1, or 2 will disable the PZD3 (PPO output) write operation to the MEMOBUS/Modbus register.

No. (Hex.)	Name	Description
F7-63 (0783)	PZD4 Write	When you use a Profibus option, sets the MEMOBUS/Modbus address for PZD4 (PPO output). A value of 0, 1, or 2 will disable the PZD4 (PPO output) write operation to the MEMOBUS/Modbus register.
F7-64 (0784)	PZD5 Write	When you use a Profibus option, sets the MEMOBUS/Modbus address for PZD5 (PPO output). A value of 0, 1, or 2 will disable the PZD5 (PPO output) write operation to the MEMOBUS/Modbus register.
F7-65 (0785)	PZD6 Write	When you use a Profibus option, sets the MEMOBUS/Modbus address for PZD6 (PPO output). A value of 0, 1, or 2 will disable the PZD6 (PPO output) write operation to the MEMOBUS/Modbus register.
F7-66 (0786)	PZD7 Write	When you use a Profibus option, sets the MEMOBUS/Modbus address for PZD7 (PPO output). A value of 0, 1, or 2 will disable the PZD7 (PPO output) write operation to the MEMOBUS/Modbus register.
F7-67 (0787)	PZD8 Write	When you use a Profibus option, sets the MEMOBUS/Modbus address for PZD8 (PPO output). A value of 0, 1, or 2 will disable the PZD8 (PPO output) write operation to the MEMOBUS/Modbus register.
F7-68 (0788)	PZD9 Write	When you use a Profibus option, sets the MEMOBUS/Modbus address for PZD9 (PPO output). A value of 0, 1, or 2 will disable the PZD9 (PPO output) write operation to the MEMOBUS/Modbus register.
F7-69 (0789)	PZD10 Write	When you use a Profibus option, sets the MEMOBUS/Modbus address for PZD10 (PPO output). A value of 0, 1, or 2 will disable the PZD10 (PPO output) write operation to the MEMOBUS/Modbus register.
F7-70 (078A)	PZD1 Read (Status Word)	When you use a Profibus option, sets the MEMOBUS/Modbus address for PZD1 (PPO input). PZD1 (PPO input) functions as the ZSW when <i>F7-70 = 0</i> .
F7-71 (078B)	PZD2 Read (Output Frequency)	When you use a Profibus option, sets the MEMOBUS/Modbus address for PZD2 (PPO input). PZD2 (PPO input) functions as the HIW when <i>F7-71 = 0</i> .
F7-72 (078C)	PZD3 Read	When you use a Profibus option, sets the MEMOBUS/Modbus address for PZD3 (PPO input). A value of 0 will disable the PZD3 (PPO input) load operation from the MEMOBUS/Modbus register.
F7-73 (078D)	PZD4 Read	When you use a Profibus option, sets the MEMOBUS/Modbus address for PZD4 (PPO input). A value of 0 will disable the PZD4 (PPO input) load operation from the MEMOBUS/Modbus register.
F7-74 (078E)	PZD5 Read	When you use a Profibus option, sets the MEMOBUS/Modbus address for PZD5 (PPO input). A value of 0 will disable the PZD5 (PPO input) load operation from the MEMOBUS/Modbus register.
F7-75 (078F)	PZD6 Read	When you use a Profibus option, sets the MEMOBUS/Modbus address for PZD6 (PPO input). A value of 0 will disable the PZD6 (PPO input) load operation from the MEMOBUS/Modbus register.
F7-76 (0790)	PZD7 Read	When you use a Profibus option, sets the MEMOBUS/Modbus address for PZD7 (PPO input). A value of 0 will disable the PZD7 (PPO input) load operation from the MEMOBUS/Modbus register.
F7-77 (0791)	PZD8 Read	When you use a Profibus option, sets the MEMOBUS/Modbus address for PZD8 (PPO input). A value of 0 will disable the PZD8 (PPO input) load operation from the MEMOBUS/Modbus register.
F7-78 (0792)	PZD9 Read	When you use a Profibus option, sets the MEMOBUS/Modbus address for PZD9 (PPO input). A value of 0 will disable the PZD9 (PPO input) load operation from the MEMOBUS/Modbus register.
F7-79 (0793)	PZD10 Read	When you use a Profibus option, sets the MEMOBUS/Modbus address for PZD10 (PPO input). A value of 0 will disable the PZD10 (PPO input) load operation from the MEMOBUS/Modbus register.

◆ H: Terminal Functions

■ H1: Digital Inputs

No. (Hex.)	Name	Description
H1-01 (0438)	Terminal S1 Function Selection	Sets the function for MFDI terminal S1.
H1-02 (0439)	Terminal S2 Function Selection	Sets the function for MFDI terminal S2.
H1-03 (0400)	Terminal S3 Function Selection	Sets the function for MFDI terminal S3.
H1-04 (0401)	Terminal S4 Function Selection	Sets the function for MFDI terminal S4.
H1-05 (0402)	Terminal S5 Function Selection	Sets the function for MFDI terminal S5.
H1-06 (0403)	Terminal S6 Function Selection	Sets the function for MFDI terminal S6.

7 Parameter List

No. (Hex.)	Name	Description
H1-07 (0404)	Terminal S7 Function Selection	Sets the function for MFDI terminal S7.
H1-08 (0405)	Terminal S8 Function Selection	Sets the function for MFDI terminal S8.
H1-61 (39E1) RUN	Terminal S1 On-Delay Time	Sets the length of time necessary for Terminal S1 to be closed before the drive does the programmed function.
H1-62 (39E2) RUN	Terminal S2 On-Delay Time	Sets the length of time necessary for Terminal S2 to be closed before the drive does the programmed function.
H1-63 (39E3) RUN	Terminal S3 On-Delay Time	Sets the length of time necessary for Terminal S3 to be closed before the drive does the programmed function.
H1-64 (39E4) RUN	Terminal S4 On-Delay Time	Sets the length of time necessary for Terminal S4 to be closed before the drive does the programmed function.
H1-65 (39E5) RUN	Terminal S5 On-Delay Time	Sets the length of time necessary for Terminal S5 to be closed before the drive does the programmed function.
H1-66 (39E6) RUN	Terminal S6 On-Delay Time	Sets the length of time necessary for Terminal S6 to be closed before the drive does the programmed function.
H1-67 (39E7) RUN	Terminal S7 On-Delay Time	Sets the length of time necessary for Terminal S7 to be closed before the drive does the programmed function.
H1-68 (39E8) RUN	Terminal S8 On-Delay Time	Sets the length of time necessary for Terminal S8 to be closed before the drive does the programmed function.
H1-71 (39EB) RUN	Terminal S1 Off-Delay Time	Sets the length of time necessary for Terminal S1 to be open before the drive removes the programmed function.
H1-72 (39EC) RUN	Terminal S2 Off-Delay Time	Sets the length of time necessary for Terminal S2 to be open before the drive removes the programmed function.
H1-73 (39ED) RUN	Terminal S3 Off-Delay Time	Sets the length of time necessary for Terminal S3 to be open before the drive removes the programmed function.
H1-74 (39EE) RUN	Terminal S4 Off-Delay Time	Sets the length of time necessary for Terminal S4 to be open before the drive removes the programmed function.
H1-75 (39EF) RUN	Terminal S5 Off-Delay Time	Sets the length of time necessary for Terminal S5 to be open before the drive removes the programmed function.
H1-76 (39F0) RUN	Terminal S6 Off-Delay Time	Sets the length of time necessary for Terminal S6 to be open before the drive removes the programmed function.
H1-77 (39F1) RUN	Terminal S7 Off-Delay Time	Sets the length of time necessary for Terminal S7 to be open before the drive removes the programmed function.
H1-78 (39F2) RUN	Terminal S8 Off-Delay Time	Sets the length of time necessary for Terminal S8 to be open before the drive removes the programmed function.

■ H1-xx: MFDI Setting Values

Setting Value	Function
3	Multi-Step Speed Reference 1
4	Multi-Step Speed Reference 2
5	Multi-Step Speed Reference 3
6	Jog Reference Selection
7	Accel/Decel Time Selection 1
8	Baseblock Command (N.O.)
9	Baseblock Command (N.C.)
A	Accel/Decel Ramp Hold
B	Overheat Alarm (oH2)
C	Analog Terminal Enable Selection
F	Not Used
14	Fault Reset
15	Fast Stop (N.O.)
17	Fast Stop (N.C.)
18	Timer Function
19	PID Disable
1B	Programming Lockout
1E	Reference Sample Hold
20	External Fault (NO-Always-Ramp)
21	External Fault (NC-Always-Ramp)
22	External Fault (NO-@Run-Ramp)
23	External Fault (NC-@Run-Ramp)
24	External Fault (NO-Always-Coast)
25	External Fault (NC-Always-Coast)
26	External Fault (NO-@Run-Coast)
27	External Fault (NC-@Run-Coast)
28	External Fault (NO-Always-FStop)
29	External Fault (NC-Always-FStop)
2A	External Fault (NO-@Run-FStop)
2B	External Fault (NC-@Run-FStop)
2C	External Fault (NO-Always-Alarm)
2D	External Fault (NC-Always-Alarm)
2E	External Fault (NO-@Run-Alarm)
2F	External Fault (NC-@Run-Alarm)
30	PID Integrator Reset
31	PID Integrator Hold
32	Multi-Step Speed Reference 4
34	PID Soft Starter Disable
35	PID Input (Error) Invert
3E	PID Setpoint Selection 1
3F	PID Setpoint Selection 2
40	Forward RUN (2-Wire)

7 Parameter List

Setting Value	Function
41	Reverse RUN (2-Wire)
44	Add Offset Frequency 1 (d7-01)
45	Add Offset Frequency 2 (d7-02)
46	Add Offset Frequency 3 (d7-03)
61	Speed Search from Fmax
62	Speed Search from Fref
63	Field Weakening
68	High Slip Braking (HSB) Activate
82	PI Switch to Aux
83	Dedicated Multi-Setpoint YA-02
84	Dedicated Multi-Setpoint YA-03
85	Dedicated Multi-Setpoint YA-04
88	Thermostat Fault
A8	PI2 Control Disable
AA	PI2 Control Inverse Operation
AB	PI2 Control Integral Reset
AC	PI2 Control Integral Hold
AD	Select PI2 Control PI Parameters
B9	Disable Pre-charge
188	!Thermostat Fault
1A8	!PI2 Control Disable

■ H2: Digital Outputs

No. (Hex.)	Name	Description
H2-01 (040B)	Term M1-M2 Function Selection	Sets the function for MFDO terminal M1-M2.
H2-02 (040C)	Term M3-M4 Function Selection	Sets the function for MFDO terminal M3-M4.
H2-03 (040D)	Term MD-ME-MF Function Selection	Sets the function for MFDO terminal MD-ME-MF.
H2-06 (0437)	Watt Hour Output Unit Selection	Sets the unit for the output signal when <i>H2-01 to H2-03 = 39</i> [MFDO Function Selection = Watt Hour Pulse Output]. 0 : 0.1 kWh units 1 : 1 kWh units 2 : 10 kWh units 3 : 100 kWh units 4 : 1000 kWh units
H2-07 (0B3A) Expert	Modbus Register 1 Address Select	Sets the address of the MEMOBUS/Modbus register output to the MFDO terminal.
H2-08 (0B3B) Expert	Modbus Register 1 Bit Select	Sets the bit of the MEMOBUS/Modbus register output to the MFDO terminal.
H2-09 (0B3C) Expert	Modbus Register 2 Address Select	Sets the address of the MEMOBUS/Modbus register output to the MFDO terminal.
H2-10 (0B3D) Expert	Modbus Register 2 Bit Select	Sets the bit of the MEMOBUS/Modbus register output to the MFDO terminal.

No. (Hex.)	Name	Description
H2-40 (0B58) Expert	Mbus Reg 15E0h bit0 Output Func	Sets the MFDO for bit 0 of MEMOBUS register 15E0 (Hex.).
H2-41 (0B59) Expert	Mbus Reg 15E0h bit1 Output Func	Sets the MFDO for bit 1 of MEMOBUS register 15E0 (Hex.).
H2-42 (0B5A) Expert	Mbus Reg 15E0h bit2 Output Func	Sets the MFDO for bit 2 of MEMOBUS register 15E0 (Hex.).
H2-60 (1B46) Expert	Term M1-M2 Secondary Function	Sets the second function for terminal M1-M2. Outputs the logical calculation results of the terminals assigned to functions by H2-01 [Term M1-M2 Function Selection].
H2-61 (1B47) Expert	Terminal M1-M2 Logical Operation	Sets the logical operation for the functions set in H2-01 [Term M1-M2 Function Selection] and H2-60 [Term M1-M2 Secondary Function].
H2-62 (1B48) Expert	Terminal M1-M2 Delay Time	Sets the minimum on time used to output the logical calculation results from terminal M1-M2.
H2-63 (1B49) Expert	Term M3-M4 Secondary Function	Sets the second function for terminal M3-M4. Outputs the logical calculation results of the terminals assigned to functions by H2-02 [Term M3-M4 Function Selection].
H2-64 (1B4A) Expert	Terminal M3-M4 Logical Operation	Sets the logical operation for the functions set in H2-02 [Term M3-M4 Function Selection] and H2-63 [Term M3-M4 Secondary Function].
H2-65 (1B4B) Expert	Terminal M3-M4 Delay Time	Sets the minimum on time used to output the logical calculation results from terminal M3-M4.
H2-66 (1B4C) Expert	Term MD-ME-MF Secondary Function	Sets the second function for terminal MD-ME-MF. Outputs the logical calculation results of the terminals assigned to functions by H2-03 [Terminal MD-ME-MF Function Select].
H2-67 (1B4D) Expert	Terminal MD-ME-MF Logical Operation	Sets the logical operation for the functions set in H2-03 [Term MD-ME-MF Function Selection] and H2-66 [Term MD-ME-MF Secondary Function].
H2-68 (1B4E) Expert	Terminal MD-ME-MF Delay Time	Sets the minimum on time used to output the logical calculation results from terminal MD-ME-MF.

■ H2-xx: MFDO Setting Values

Note:

The functions listed here will only activate when you operate in Drive Mode. They will not activate in Bypass Mode.

Setting Value	Function
0	During Run
1	Zero Speed
2	Speed Agree 1
3	User-Set Speed Agree 1
4	Frequency Detection 1
5	Frequency Detection 2
6	Drive Ready
7	DC Bus Undervoltage
8	During Baseblock (N.O.)
9	Frequency Reference from Keypad
B	Torque Detection 1 (N.O.)

7 Parameter List

Setting Value	Function
C	Frequency Reference Loss
E	Fault
F	Not Used
10	Alarm
11	Fault Reset Command Active
12	Timer Output
13	Speed Agree 2
14	User-Set Speed Agree 2
15	Frequency Detection 3
16	Frequency Detection 4
17	Torque Detection 1 (N.C.)
18	Torque Detection 2 (N.O.)
19	Torque Detection 2 (N.C.)
1A	During Reverse
1B	During Baseblock (N.C.)
1E	Executing Auto-Restart
1F	Motor Overload Alarm (oL1)
20	Drive Overheat Pre-Alarm (oH)
21	Safe Torque OFF
2F	Maintenance Notification
37	During Frequency Output
38	Drive Enabled
39	Watt Hour Pulse Output
3A	Drive Overheat Alarm
3D	During Speed Search
42	Pressure Reached
4C	During Fast Stop
4D	oH Pre-Alarm Reduction Limit
58	UL6 Underload Detected
60	Internal Cooling Fan Failure
62	Modbus Reg 1 Status Satisfied
63	Modbus Reg 2 Status Satisfied
71	Low PI2 Control Feedback Level
72	High PI2 Control Feedback Level
89	Output Current Lim
94	Loss of Prime
95	Thermostat Fault
96	High Feedback
97	Low Feedback
9E	Low PI Auxiliary Control Level
9F	High PI Auxiliary Control Level
A9	RELAY Operator Control
AB	Thrust Mode

Setting Value	Function
AC	Setpoint Not Maintained
B8	Pump Fault
B9	Transducer Loss
BA	PI Auxiliary Control Active
BB	Differential Feedback Exceeded
BC	Sleep Active
BD	Start Delay
BE	Pre-Charge
C3	Main Feedback Lost
C4	Backup Feedback Lost
100	!During Run
101	!Zero Speed
102	!Speed Agree 1
103	!User-Set Speed Agree 1
104	!Frequency Detection 1
105	!Frequency Detection 2
106	!Drive Ready
107	!DC Bus Undervoltage
108	!During Baseblock (N.O.)
109	!Frequency Reference from Keypad
10B	!Torque Detection 1 (N.O.)
10C	!Frequency Reference Loss
10E	!Fault
110	!Alarm
111	!Fault Reset Command Active
112	!Timer Output
113	!Speed Agree 2
114	!User-Set Speed Agree 2
115	!Frequency Detection 3
116	!Frequency Detection 4
117	!Torque Detection 1 (N.C.)
118	!Torque Detection 2 (N.O.)
119	!Torque Detection 2 (N.C.)
11A	!During Reverse
11B	!During Baseblock (N.C.)
11E	!Executing Auto-Restart
11F	!Motor Overload Alarm (oL1)
120	!Drive Overheat Pre-Alarm (oH)
121	!Safe Torque OFF
12F	!Maintenance Notification
137	!During Frequency Output
138	!Drive Enabled
139	!Watt Hour Pulse Output

7 Parameter List

Setting Value	Function
13A	!Drive Overheat Alarm
13D	!During Speed Search
142	!Pressure Reached
14C	!During Fast Stop
14D	!oH Pre-Alarm Reduction Limit
158	!UL6 Underload Detected
160	!Internal Cooling Fan Failure
162	!Modbus Reg 1 Status Satisfied
163	!Modbus Reg 2 Status Satisfied
171	!Low PI2 Control Feedback Level
172	!High PI2 Control Feedback Level
189	!Output Current Lim
194	!Loss of Prime
195	!Thermostat Fault
196	!High Feedback
197	!Low Feedback
19E	!Low PI Auxiliary Control Level
19F	!High PI Auxiliary Control Level
1A9	!RELAY Operator Control
1AB	!Thrust Mode
1AC	!Setpoint Not Maintained
1B8	!Pump Fault
1B9	!Transducer Loss
1BA	!PI Auxiliary Control Active
1BB	!Differential Feedback Exceeded
1BC	!Sleep Active
1BD	!Start Delay
1BE	!Pre-Charge
1C3	!Main Feedback Lost
1C4	!Backup Feedback Lost

■ H3: Analog Inputs

No. (Hex.)	Name	Description
H3-01 (0410)	Terminal A1 Signal Level Select	Sets the input signal level for MFAI terminal A1. 0 : 0 to 10V (Lower Limit at 0) 2 : 4 to 20 mA 3 : 0 to 20 mA
H3-02 (0434)	Terminal A1 Function Selection	Sets the function for MFAI terminal A1.
H3-03 (0411) RUN	Terminal A1 Gain Setting	Sets the gain of the analog signal input to MFAI terminal A1.
H3-04 (0412) RUN	Terminal A1 Bias Setting	Sets the bias of the analog signal input to MFAI terminal A1.

No. (Hex.)	Name	Description
H3-05 (0413)	Terminal A3 Signal Level Select	Sets the input signal level for MFAI terminal A3. 0 : 0-10V (Lower Limit at 0) 2 : 4 to 20 mA 3 : 0 to 20 mA
H3-06 (0414)	Terminal A3 Function Selection	Sets the function for MFAI terminal A3.
H3-07 (0415) RUN	Terminal A3 Gain Setting	Sets the gain of the analog signal input to MFAI terminal A3.
H3-08 (0416) RUN	Terminal A3 Bias Setting	Sets the bias of the analog signal input to MFAI terminal A3.
H3-09 (0417)	Terminal A2 Signal Level Select	Sets the input signal level for MFAI terminal A2. 0 : 0-10V (LowLim=0) 2 : 4 to 20 mA 3 : 0 to 20 mA
H3-10 (0418)	Terminal A2 Function Selection	Sets the function for MFAI terminal A2.
H3-11 (0419) RUN	Terminal A2 Gain Setting	Sets the gain of the analog signal input to MFAI terminal A2.
H3-12 (041A) RUN	Terminal A2 Bias Setting	Sets the bias of the analog signal input to MFAI terminal A2.
H3-13 (041B)	Analog Input FilterTime Constant	Sets the time constant for primary delay filters on MFAI terminals.
H3-14 (041C)	Analog Input Terminal Enable Sel	Sets the enabled terminal or terminals when $H1-xx = C$ [<i>MFDI Function Select = Analog Terminal Enable Selection</i>] is ON. 1 : Terminal A1 only 2 : Terminal A2 only 3 : Terminals A1 and A2 4 : Terminal A3 only 5 : Terminals A1 and A3 6 : Terminals A2 and A3 7 : Terminals A1, A2, and A3
H3-16 (02F0)	Terminal A1 Offset	Sets the offset level for analog signals input to terminal A1. Usually it is not necessary to change this setting.
H3-17 (02F1)	Terminal A2 Offset	Sets the offset level for analog signals input to terminal A2. Usually it is not necessary to change this setting.
H3-18 (02F2)	Terminal A3 Offset	Sets the offset level for analog signals input to terminal A3. Usually it is not necessary to change this setting.
H3-40 (0B5C) Expert	Mbus Reg 15C1h Input Function	Sets the MEMOBUS AI1 function.
H3-41 (0B5F) Expert	Mbus Reg 15C2h Input Function	Sets the MEMOBUS AI2 function.
H3-42 (0B62) Expert	Mbus Reg 15C3h Input Function	Sets the MEMOBUS AI3 function.
H3-43 (117F)	Mbus Reg Inputs FilterTime Const	Sets the time constant to apply a primary delay filter to the MEMOBUS analog input register values.

■ H3-xx: MFAI Setting Values

Setting Value	Function
0	Frequency Reference
1	Frequency Gain
2	Auxiliary Frequency Reference 1
3	Auxiliary Frequency Reference 2
4	Output Voltage Bias
5	Accel/Decel Time Gain
6	DC Injection Braking Current
7	Torque Detection Level
8	Stall Prevent Level During Run
9	Output Frequency Lower Limit
B	PID Feedback
C	PID Setpoint
D	Frequency Bias
E	Motor Temperature (PTC Input)
F	Not Used
16	Differential PID Feedback
1F	Not Used
24	PID Feedback Backup
25	PI2 Control Setpoint
26	PI2 Control Feedback
27	PI Auxiliary Control Feedback
2B	Emergency Override PID Feedback
2C	Emergency Override PID Setpoint
2D	Differential Level Source
2E	HAND Frequency Ref or Setpoint

■ H4: Analog Outputs

No. (Hex.)	Name	Description
H4-01 (041D)	Terminal FM Analog Output Select	Sets the monitor number to send from MFAO terminal FM.
H4-02 (041E) RUN	Terminal FM Analog Output Gain	Sets the gain of the monitor signal that is sent from MFAO terminal FM.
H4-03 (041F) RUN	Terminal FM Analog Output Bias	Sets the bias of the monitor signal that is sent from MFAO terminal FM.
H4-04 (0420)	Terminal AM Analog Output Select	Sets the monitoring number to be output from the MFAO terminal AM.
H4-05 (0421) RUN	Terminal AM Analog Output Gain	Sets the gain of the monitor signal that is sent from MFAO terminal AM.
H4-06 (0422) RUN	Terminal AM Analog Output Bias	Sets the bias of the monitor signal that is sent from MFAO terminal AM.

No. (Hex.)	Name	Description
H4-07 (0423)	Terminal FM Signal Level Select	Sets the MFAO terminal FM output signal level. 0 : 0 to 10 Vdc 2 : 4 to 20 mA
H4-08 (0424)	Terminal AM Signal Level Select	Sets the MFAO terminal AM output signal level. 0 : 0 to 10 Vdc 2 : 4 to 20 mA
H4-20 (0B53)	Analog Power Monitor 100% Level	Sets the level at 10 V when you set <i>UI-08 [Output Power]</i> for analog output.

■ H5: Serial Communication

Note:

H5-xx parameters affect the bypass controller RS-485 terminals, TB3 Terminals 1 to 4.

No. (Hex.)	Name	Description
H5-01 (0425)	Drive Node Address	Sets the communication slave address for drives.
H5-02 (0426)	Communication Speed Selection	Sets the communications speed for serial communications. 0 : 1200 bps 1 : 2400 bps 2 : 4800 bps 3 : 9600 bps 4 : 19.2 kbps 5 : 38.4 kbps 6 : 57.6 kbps 7 : 76.8 kbps 8 : 115.2 kbps
H5-03 (0427)	Communication Parity Selection	Sets the communications parity used for serial communications. 0 : No parity 1 : Even parity 2 : Odd parity
H5-04 (0428)	Communication Error Stop Method	Sets the motor Stopping Method when the drive detects a serial communication Error condition. 0 : Ramp to Stop 1 : Coast to Stop 2 : Fast Stop (Use C1-09) 3 : Alarm Only 4 : Run at H5-34 (CE Go-To-Freq)
H5-05 (0429)	Comm Fault Detection Selection	Sets the function that detects <i>CE [Serial Communication Error]</i> issues during serial communications. 0 : Disabled 1 : Enabled
H5-06 (042A)	Drive Transmit Wait Time	Sets the time to wait to send a response message after the drive receives a command message from the master.
H5-08 (062D)	Communication Protocol Selection	Selects the communication protocol. 0 : Modbus/MEMOBUS 1 : Metasys/N2 2 : Apogee/P1 3 : BACnet
H5-09 (0435)	CE Detection Time	Sets the detection time for <i>CE [Serial Communication Error]</i> issues when communication stops.
H5-10 (0436)	Modbus Register 0025H Unit Sel	Sets the unit of measure used for the serial communications monitor register 0025H (output voltage reference monitor). 0 : 0.1 V units 1 : 1 V units
H5-11 (043C)	Comm ENTER Command Mode	Sets the function to make the Enter command necessary to change parameters through serial communications. 0 : ENTER Command Required 1 : ENTER Command Not Required
H5-14 (310D)	BACnet Device Obj ID LOW BITS	Sets the lower bits of the BACnet device object ID as a 4-digit hexadecimal number.

7 Parameter List

No. (Hex.)	Name	Description
H5-15 (310E)	BACnet Device Obj ID HIGH BITS	Sets the upper bits of the BACnet device object ID as a 4-digit hexadecimal number.
H5-18 (11A2)	Motor Speed Filter over Comms	Sets the filter time constant used when monitoring motor speed during serial communications or with a communication option.
H5-20 (0B57)	Communication Parameters Reload	Sets the function to immediately enable updated serial communications parameters. 0 : Reload at Next Power Cycle 1 : Reload Now
H5-22 (11CF)	Speed Search from MODBUS	Enables the serial communication register Speed Search function (bit 0 of 15DFH). 0 : Disabled 1 : Enabled
H5-23 (158D)	BACnet Max Master	Sets the maximum number of master MAC ID to scan to when the drive polls for the next node (Poll for Master).
H5-24 (3DA0)	BACnet Max Info Frames	Sets the maximum number of information frames that the bypass will send per token cycle in BACnet.
H5-25 (1589) RUN Expert	Function 5A Register 1 Selection	Returns the contents of the specified serial communications register when responding to the master device.
H5-26 (158A) RUN Expert	Function 5A Register 2 Selection	Returns the contents of the specified serial communications register when responding to the master device.
H5-27 (158B) RUN Expert	Function 5A Register 3 Selection	Returns the contents of the specified serial communications register when responding to the master device.
H5-28 (158C) RUN Expert	Function 5A Register 4 Selection	Returns the contents of the specified serial communications register when responding to the master device.
H5-33 (3FB3)	Power-up CALL Alarm	Enables and disables <i>CALL [Serial Comm Transmission Error]</i> alarm detection. 0 : Disabled 1 : Enabled
H5-34 (3FB4) RUN	Comm Error (CE) Go-To-Frequency	Sets the speed at which the drive will run when <i>H5-04 = 4 [Communication Error Stop Method = Run at H5-34]</i> and there is a <i>CE</i> .
H5-35 (3FB5) RUN	Comm Error (CE) Go-To-Timeout	When <i>H5-04 = 4 [Communication Error Stop Method = Run at H5-34]</i> and a <i>CE</i> is present, the drive will run at the <i>H5-34 [Comm Error (CE) Go-To-Frequency]</i> speed for this length of time before it triggers a <i>CE</i> fault.
H5-36 (3FB6)	CE Fault Restart Select	Sets the drive to restart (<i>L5-01 [Number of Auto-Restart Attempts]</i>) after a <i>CE</i> fault. 0 : No Retry 1 : Retry

■ H6: Pulse Train Input

No. (Hex.)	Name	Description
H6-01 (042C)	Terminal RP Pulse Train Function	Sets the function for pulse train input terminal RP. 0 : Not Used 1 : PID Feedback Value 2 : PID Setpoint Value
H6-02 (042D) RUN	Terminal RP Frequency Scaling	Sets the frequency of the pulse train input signal used when the item selected with <i>H6-01 [Terminal RP Pulse Train Function]</i> is input at 100%.
H6-03 (042E) RUN	Terminal RP Function Gain	Sets the gain used when the function in <i>H6-01 [Terminal RP Pulse Train Function]</i> is input to terminal RP.

No. (Hex.)	Name	Description
H6-04 (042F) RUN	Terminal RP Function Bias	Sets the bias used when the function in H6-01 [Terminal RP Pulse Train Function] is input to terminal RP. Sets a value at the time when the pulse train is 0 Hz.
H6-05 (0430) RUN	Terminal RP Filter Time	Sets the time constant for the pulse train input primary delay filters.
H6-08 (043F)	Terminal RP Minimum Frequency	Sets the minimum frequency of the pulse train signal that terminal RP can detect.

■ H7: Virtual MFIO selection

No. (Hex.)	Name	Description
H7-00 (116F) Expert	Virtual MFIO selection	Sets the function to enable and disable the virtual I/O function. Set this parameter to 1 to operate the virtual I/O function. 0 : Disabled 1 : Enabled
H7-01 (1185) Expert	Virtual Multi-Function Input 1	Sets the function that enters the virtual input set in H7-10 [Virtual Multi-Function Output 1].
H7-02 (1186) Expert	Virtual Multi-Function Input 2	Sets the function that enters the virtual input set in H7-12 [Virtual Multi-Function Output 2].
H7-03 (1187) Expert	Virtual Multi-Function Input 3	Sets the function that enters the virtual input set in H7-14 [Virtual Multi-Function Output 3].
H7-04 (1188) Expert	Virtual Multi-Function Input 4	Sets the function that enters the virtual input set in H7-16 [Virtual Multi-Function Output 4].
H7-10 (11A4) Expert	Virtual Multi-Function Output 1	Sets the function for virtual digital output 1.
H7-11 (11A5) Expert	Virtual Output 1 Delay Time	Sets the minimum ON time for virtual digital output 1.
H7-12 (11A6) Expert	Virtual Multi-Function Output 2	Sets the function for virtual digital output 2.
H7-13 (11A7) Expert	Virtual Output 2 Delay Time	Sets the minimum ON time for virtual digital output 2.
H7-14 (11A8) Expert	Virtual Multi-Function Output 3	Sets the function for virtual digital output 3.
H7-15 (11A9) Expert	Virtual Output 3 Delay Time	Sets the minimum ON time for virtual digital output 3.
H7-16 (11AA) Expert	Virtual Multi-Function Output 4	Sets the function for virtual digital output 4.
H7-17 (11AB) Expert	Virtual Output 4 Delay Time	Sets the minimum ON time for virtual digital output 4.
H7-30 (1177) Expert	Virtual Analog Input Selection	Sets the virtual analog input function.

7 Parameter List

No. (Hex.)	Name	Description
H7-31 (1178) RUN Expert	Virtual Analog Input Gain	Sets the virtual analog input gain.
H7-32 (1179) RUN Expert	Virtual Analog Input Bias	Sets the virtual analog input bias.
H7-40 (1163) Expert	Virtual Analog Out Signal Select	Sets the signal level of the virtual analog output. 0 : 0 to 100% (Absolute Value) 1 : -100 to 100% 2 : 0 to 100% (Lower Limit at 0)
H7-41 (1164) Expert	Virtual Analog Output Function	Sets the monitor to be output from the virtual analog output.
H7-42 (1165) Expert	Virtual Analog Output FilterTime	Sets the time constant for a primary filter of the virtual analog output.

◆ L: Protection Functions

■ L1: Motor Protection

No. (Hex.)	Name	Description
L1-01 (0480)	Motor Overload (oL1) Protection	Sets the motor overload protection with electronic thermal protectors. 0 : Disabled 1 : Variable Torque 2 : Constant Torque 10:1 Speed Range
L1-02 (0481)	Motor Overload Protection Time	Sets the operation time for the electronic thermal protector of the drive to prevent damage to the motor. Usually it is not necessary to change this setting.
L1-03 (0482)	Motor Thermistor oH Alarm Select	Sets drive operation when the PTC input signal entered into the drive is at the <i>oH3 [Motor Overheat Alarm]</i> detection level. 0 : Ramp to Stop 1 : Coast to Stop 2 : Fast Stop (Use C1-09) 3 : Alarm Only
L1-04 (0483)	Motor Thermistor oH Fault Select	Sets the drive operation when the PTC input signal to the drive is at the <i>oH4 [Motor Overheat Fault (PTC Input)]</i> detection level. 0 : Ramp to Stop 1 : Coast to Stop 2 : Fast Stop (Use C1-09)
L1-05 (0484)	Motor Thermistor Filter Time	Sets the primary delay time constant for the PTC input signal entered to the drive. This parameter prevents accidental motor overheat faults.
L1-08 (1103) Expert	oL1 Current Level	Sets the reference current for the motor 1 thermal overload detection. When the current level > 0.0 A, you cannot set this value < 10% of drive rated current.
L1-13 (046D)	Motor Overload Memory Selection	Sets the function that keeps the current electronic thermal protector value after power loss. 0 : Disabled 1 : Enabled 2 : Enabled, using RTC

■ L2: Power Loss Ride Through

No. (Hex.)	Name	Description
L2-01 (0485)	Power Loss Ride Through Select	Sets the drive operation after a momentary power loss. 0 : Disabled 1 : Enabled for L2-02 Time 2 : Enabled while CPU Power Active
L2-02 (0486)	Power Loss Ride Through Time	Sets the maximum time that the drive will wait until it tries to restart after power loss.
L2-03 (0487)	Minimum Baseblock Time	Sets the minimum time to continue the drive output block (baseblock) after a baseblock.
L2-04 (0488)	Powerloss V/f Recovery Ramp Time	Sets the time for the drive output voltage to go back to the correct voltage after it completes speed searches.
L2-05 (0489)	Undervoltage Detection Lvl (Uv1)	Sets the voltage at which the drive triggers a <i>Uv1 [DC Bus Undervoltage]</i> fault. Usually it is not necessary to change this setting.

■ L3: Stall Prevention

No. (Hex.)	Name	Description
L3-01 (048F)	Stall Prevention during Accel	Sets the method of Stall Prevention During Acceleration. 0 : Disabled 1 : Enabled 2 : Intelligent (Ignore Decel Ramp)
L3-02 (0490)	Stall Prevent Level during Accel	Sets the output current level to activate the Stall Prevention function during acceleration as a percentage of the drive rated output current.
L3-03 (0491)	Stall Prevent Limit during Accel	Sets the lower limit for the stall prevention level used in the constant output range as a percentage of the drive rated output current.
L3-04 (0492)	Stall Prevention during Decel	Sets the method that the drive will use to prevent overvoltage faults when decelerating. 0 : Disabled 1 : General Purpose 2 : Intelligent (Ignore Decel Ramp) 4 : Overexcitation/High Flux 5 : Overexcitation/High Flux 2
L3-05 (0493)	Stall Prevention during RUN	Sets the function to enable and disable Stall Prevention During Run. 0 : Disabled 1 : Deceleration Time 1 (C1-02) 2 : Deceleration Time 2 (C1-04)
L3-06 (0494)	Stall Prevent Level during Run	Sets the output current level to enable the Stall Prevention function during operation as a percentage of the drive rated output current.
L3-11 (04C7)	Overvoltage Suppression Select	Sets the overvoltage suppression function. 0 : Disabled 1 : Enabled
L3-17 (0462)	DC Bus Regulation Level	Sets the target value for the DC bus voltage when the overvoltage suppression function and the Decel Stall Prevention function (Intelligent Stall Prevention) are active.
L3-20 (0465) Expert	DC Bus Voltage Adjustment Gain	Sets the proportional gain used to control the DC bus voltage.
L3-21 (0466) Expert	OVSUPPRESSION Accel/Decel P Gain	Sets the proportional gain to calculate acceleration and deceleration rates.
L3-23 (04FD)	Stall P Reduction at Constant HP	Sets the function to automatically decrease the Stall Prevention Level during Run for constant output ranges. 0 : Use L3-06 for Entire Speed Range 1 : Automatic Reduction @ CHP Region
L3-24 (046E) Expert	Motor Accel Time @ Rated Torque	Sets the motor acceleration time to reach the maximum frequency at the motor rated torque for stopped single-drive motors.

7 Parameter List

No. (Hex.)	Name	Description
L3-25 (046F) Expert	Load Inertia Ratio	Sets the ratio between motor inertia and machine inertia.
L3-26 (0455) Expert	Additional DC Bus Capacitors	Sets the capacity for external main circuit capacitors. Usually it is not necessary to change this setting.
L3-27 (0456)	Stall Prevention Detection Time	Sets a delay time between reaching the Stall Prevention level and starting the Stall Prevention function.
L3-35 (0747) Expert	Speed Agree Width for Auto Decel	Sets the width for speed agreement when $L3-04 = 2$ [Decel Stall Prevention Selection = Automatic Decel Reduction]. Usually it is not necessary to change this setting.

■ L4: Speed Detection

No. (Hex.)	Name	Description
L4-01 (0499)	Speed Agree Detection Level	Sets the level to detect speed agree or motor speed when $H2-01$ to $H2-03 = 2, 3, 4, 5$ [MFDO Function Selection = Speed Agree 1, User-set Speed Agree 1, Frequency Detection 1, Frequency Detection 2].
L4-02 (049A)	Speed Agree Detection Width	Sets the width to detect speed agree or motor speed when $H2-01$ to $H2-03 = 2, 3, 4, 5$ [MFDO Function Selection = Speed Agree 1, User-set Speed Agree 1, Frequency Detection 1, Frequency Detection 2].
L4-03 (049B)	Speed Agree Detection Level (+/-)	Sets the speed agree detection level or motor speed detection level when $H2-01$ to $H2-03 = 13, 14, 15, 16$ [MFDO Function Selection = Speed Agree 2, User-set Speed Agree 2, Frequency Detection 3, Frequency Detection 4].
L4-04 (049C)	Speed Agree Detection Width (+/-)	Sets the width to detect speed agree or motor speed when $H2-01$ to $H2-03 = 13, 14, 15, 16$ [MFDO Function Selection = Speed Agree 2, User-set Speed Agree 2, Frequency Detection 3, Frequency Detection 4].
L4-05 (049D)	Fref Loss Detection Selection	Sets the operation when the drive detects a loss of frequency reference. 0 : Stop 1 : Run at (L4-06 x Last Reference)
L4-06 (04C2)	Frequency Reference @Loss of Ref	Sets the frequency reference as a percentage to continue drive operation after it detects a frequency reference loss. The value is a percentage of the frequency reference before the drive detected the loss.
L4-07 (0470)	Speed Agree Detection Selection	Sets the condition that activates speed detection. 0 : No Detection during Baseblock 1 : Detection Always Enabled

■ L5: Fault Restart

No. (Hex.)	Name	Description
L5-01 (049E)	Number of Auto-Restart Attempts	Sets the number of times that the drive will try to restart.
L5-02 (049F)	Fault Contact at Restart Select	Sets the function that sends signals to the MFDO terminal set for <i>Fault</i> [$H2-xx = E$] while the drive is automatically restarting. 0 : Active Only when Not Restarting 1 : Always Active
L5-04 (046C)	Interval Method Restart Time	Sets the time interval between each Auto Restart attempt.

■ L6: Torque Detection

No. (Hex.)	Name	Description
L6-01 (04A1)	Torque Detection Selection 1	Sets the speed range that detects overtorque and undertorque and the operation of drives (operation status) after detection. 0 : Disabled 1 : oL @ Speed Agree - Alarm only 2 : oL @ RUN - Alarm only 3 : oL @ Speed Agree - Fault 4 : oL @ RUN - Fault 5 : UL @ Speed Agree - Alarm only 6 : UL @ RUN - Alarm only 7 : UL @ Speed Agree - Fault 8 : UL @ RUN - Fault 9 : UL6 @ Speed Agree - Alarm only 10 : UL6 @ RUN - Alarm only 11 : UL6 @ Speed Agree - Fault 12 : UL6 @ RUN - Fault
L6-02 (04A2)	Torque Detection Level 1	Sets the detection level for Overtorque/Undertorque Detection 1. In V/f control, drive rated output current = 100% value.
L6-03 (04A3)	Torque Detection Time 1	Sets the detection time for Overtorque/Undertorque Detection 1.
L6-04 (04A4)	Torque Detection Selection 2	Sets the speed range that detects overtorque and undertorque and the operation of drives (operation status) after detection. 0 : Disabled 1 : oL @ Speed Agree - Alarm only 2 : oL @ RUN - Alarm only 3 : oL @ Speed Agree - Fault 4 : oL @ RUN - Fault 5 : UL @ Speed Agree - Alarm only 6 : UL @ RUN - Alarm only 7 : UL @ Speed Agree - Fault 8 : UL @ RUN - Fault
L6-05 (04A5)	Torque Detection Level 2	Sets the detection level for Overtorque/Undertorque Detection 2. In V/f control, drive rated output current = 100% value.
L6-06 (04A6)	Torque Detection Time 2	Sets the detection time for Overtorque/Undertorque Detection 2.
L6-13 (062E)	Motor Underload Curve Select	Sets the motor underload protection (<i>UL6 [Undertorque Detection 6]</i>) based on motor load and sets the level of <i>L6-02 [Torque Detection Level 1]</i> to refer to Fbase or Fmax. 0 : Base Frequency Enable 1 : Max Frequency Enable
L6-14 (062F)	Motor Underload Level @ Min Freq	Sets the <i>UL6 [Undertorque Detection 6]</i> detection level at minimum frequency by percentage of drive rated current.

■ L8: Drive Protection

No. (Hex.)	Name	Description
L8-02 (04AE)	Overheat Alarm Level	Sets the <i>oH</i> detection level temperature.
L8-03 (04AF)	Overheat Pre-Alarm Selection	Sets drive operation if it detects an <i>oH</i> alarm. 0 : Ramp to Stop 1 : Coast to Stop 2 : Fast Stop (Use C1-09) 3 : Alarm Only 4 : Operate at Reduced Speed (L8-19)
L8-05 (04B1)	Input Phase Loss Protection Sel	Sets the function to enable and disable input phase loss detection. 0 : Disable 1 : Enabled
L8-07 (04B3)	Output Phase Loss Protection Sel	Sets the function to enable and disable output phase loss detection. The drive starts output phase loss detection when the output current decreases to less than 5% of the drive rated current. 0 : Disabled 1 : Fault when one phase is lost 2 : Fault when two phases are lost

No. (Hex.)	Name	Description
L8-09 (04B5)	Output Ground Fault Detection	Sets the function to enable and disable ground fault protection. 0 : Disabled 1 : Enabled
L8-10 (04B6)	Heatsink Fan Operation Selection	Sets operation of the heatsink cooling fan. 0 : During Run, w/ L8-11 Off-Delay 1 : Always On 2 : On when Drive Temp Reaches L8-64
L8-11 (04B7)	Heatsink Fan Off-Delay Time	Sets the length of time that the drive will wait before it stops the cooling fan after it cancels the Run command when <i>L8-10 = 0</i> [<i>Heatsink Fan Operation Selection = During Run, w/ L8-11 Off-Delay</i>].
L8-12 (04B8)	Ambient Temperature Setting	Sets the ambient temperature of the drive installation area.
L8-15 (04BB)	Drive oL2 @ Low Speed Protection	Sets the function to decrease drive overload at low speeds to prevent damage to the main circuit transistor during low speed operation (at 6 Hz or slower) to prevent oL2 [<i>Drive Overloaded</i>]. 0 : Disabled (No Additional Derate) 1 : Enabled (Reduced oL2 Level)
L8-18 (04BE)	Software Current Limit Selection	Set the software current limit selection function to prevent damage to the main circuit transistor caused by too much current. 0 : Disabled 1 : Enabled
L8-19 (04BF)	Freq Reduction @ oH Pre-Alarm	Sets the ratio at which the drive derates the frequency reference during an oH alarm.
L8-35 (04EC)	Installation Method Selection	Sets the type of drive installation. 0 : IP20/UL Open Type 1 : Side-by-Side Mounting 2 : IP20/UL Type 1 3 : IP55/UL Type 12
L8-38 (04EF)	Carrier Frequency Reduction	Sets the carrier frequency reduction function. The drive decreases the carrier frequency when the output current is more than a specified level. 1 : Enabled below 6 Hz 2 : Enabled for All Speeds 3 : Enable at Overload
L8-41 (04F2)	High Current Alarm Selection	Sets the function to cause an HCA [<i>High Current Alarm</i>] when the output current is more than 150% of the drive rated current. 0 : Disabled 1 : Enabled
L8-97 (3104)	Carrier Freq Reduce during OH	Sets the function to decrease carrier frequency during oH pre-alarm. 0 : Disabled 1 : Enabled

■ L9: Drive Protection 2

No. (Hex.)	Name	Description
L9-16 (11DC) Expert	FAn1 Detect Time	Sets the detection time for <i>FAn1</i> [<i>Drive Cooling Fan Fault</i>]. Yaskawa recommends that you do not change this parameter value.

◆ n: Special Adjustment

■ n1: Hunting Prevention

No. (Hex.)	Name	Description
n1-01 (0580)	Hunting Prevention Selection	Sets the function to prevent hunting. 0 : Disabled 1 : Enabled (Normal)
n1-02 (0581) Expert	Hunting Prevention Gain Setting	Sets the performance of the hunting prevention function. Usually it is not necessary to change this parameter.

7 Parameter List

No. (Hex.)	Name	Description
n1-03 (0582) Expert	Hunting Prevention Time Constant	Sets the primary delay time constant of the hunting prevention function. Usually it is not necessary to change this parameter.
n1-05 (0530) Expert	Hunting Prevent Gain in Reverse	Sets the performance of the hunting prevention function. This parameter adjusts Reverse run. Usually it is not necessary to change this parameter.
n1-13 (1B59) Expert	DC Bus Stabilization Control	Sets the oscillation suppression function for the DC bus voltage. 0 : Disabled 1 : Enabled
n1-14 (1B5A) Expert	DC Bus Stabilization Time	Adjusts the responsiveness of the oscillation suppression function for the DC bus voltage. Set $n1-13 = 1$ [DC Bus Stabilization Control = Enabled] to enable this parameter.

■ n3: HighSlip/OverexciteBraking

No. (Hex.)	Name	Description
n3-01 (0588) Expert	HSB Deceleration Frequency Width	Sets the amount by which the output frequency is to be lowered during high-slip braking, as a percentage of $E1-04$ [Maximum Output Frequency], which represents the 100% value.
n3-02 (0589) Expert	HSB Current Limit Level	Sets the maximum current output during high-slip braking as a percentage, where $E2-01$ [Motor Rated Current (FLA)] is 100%. Also sets the current suppression to prevent exceeding drive overload tolerance.
n3-03 (058A) Expert	HSB Dwell Time at Stop	Sets the dwell time, a length of time when high-slip braking is ending and during which the motor speed decreases and runs at a stable speed. For a set length of time, the drive will hold the actual output frequency at the minimum output frequency set in $E1-09$.
n3-04 (058B) Expert	HSB Overload Time	Sets the time used to detect $oL7$ [High Slip Braking Overload], which occurs when the output frequency does not change during high-slip braking. Usually it is not necessary to change this parameter.
n3-13 (0531) Expert	OverexcitationBraking (OEB) Gain	Sets the gain value that the drive multiplies by the V/f pattern output value during overexcitation deceleration to calculate the overexcitation level.
n3-14 (0532) Expert	OEB High Frequency Injection	Sets the function that injects harmonic signals during overexcitation deceleration. 0 : Disabled 1 : Enabled
n3-21 (0579) Expert	HSB Current Suppression Level	Sets the upper limit of the current that is suppressed at the time of overexcitation deceleration as a percentage of the drive rated current.
n3-23 (057B) Expert	Overexcitation Braking Operation	Sets the direction of motor rotation where the drive will enable overexcitation. 0 : Disabled 1 : Enabled Only when Rotating FWD 2 : Enabled Only when Rotating REV

◆ o: Keypad-Related Settings

■ o1: Keypad Display

No. (Hex.)	Name	Description
o1-03 (0502)	Frequency Display Unit Selection	Sets the display units for the frequency reference and output frequency. 0 : 0.01Hz units 1 : 0.01% units 2 : min^{-1} (r/min) unit 3 : User Units (o1-09 -o1-11)
o1-05 (0504) RUN	LCD Contrast Adjustment	Sets the contrast of the LCD display on the keypad.



No. (Hex.)	Name	Description
o1-09 (051C)	Freq. Reference Display Units	Sets the unit of display for the frequency reference parameters and frequency-related monitors when $o1-03 = 3$ [<i>Frequency Display Unit Selection = User Units (o1-09 ~ o1-11)</i>]. 0 : "WC: inches of water column 1 : PSI: pounds per square inch 2 : GPM: gallons/min 3 : °F: Fahrenheit 4 : ft ³ /min: cubic feet/min 5 : m ³ /h: cubic meters/hour 6 : L/h: liters/hour 7 : L/s: liters/sec 8 : bar: bar 9 : Pa: Pascal 10 : °C: Celsius 11 : m: meters 12 : ft: feet 13 : L/min: liters/min 14 : m ³ /min: cubic meters/min 15 : "Hg: Inch Mercury 16 : kPa: kilopascal 48 : %: Percent 49 : Custom(o1-13~15) 50 : None
o1-10 (0520)	User Units Maximum Value	Sets the value that the drive shows as the maximum output frequency.
o1-11 (0521)	User Units Decimal Position	Sets the number of decimal places for frequency reference and monitor values. 0 : No Decimal Places (XXXXX) 1 : One Decimal Places (XXXX.X) 2 : Two Decimal Places (XXX.XX) 3 : Three Decimal Places (XX.XXX)
o1-13 (3105)	Freq. Reference Custom Unit 1	Sets the first character of the custom unit display when $o1-03 = 3$ [<i>Frequency Display Unit Selection = User Units</i>] and $o1-09 = 49$ [<i>Freq. Reference Display Units = Custom (o1-13~15)</i>].
o1-14 (3106)	Freq. Reference Custom Unit 2	Sets the second character of the custom unit display when $o1-03 = 3$ [<i>Frequency Display Unit Selection = User Units</i>] and $o1-09 = 49$ [<i>Freq. Reference Display Units = Custom (o1-13~15)</i>].
o1-15 (3107)	Freq. Reference Custom Unit 3	Sets the third character of the custom unit display when $o1-03 = 3$ [<i>Frequency Display Unit Selection = User Units</i>] and $o1-09 = 49$ [<i>Freq. Reference Display Units = Custom (o1-13~15)</i>].
o1-18 (310A)	User Defined Parameter 1	Lets you set values to use as reference information.
o1-19 (310B)	User Defined Parameter 2	Lets you set values to use as reference information.
o1-24 (11AD) RUN	Custom Monitor 1	Sets Custom Monitor 1. You can set a maximum of 12 monitors as user monitors. This parameter is only available on an HOA keypad.
o1-25 (11AE) RUN	Custom Monitor 2	Sets Custom Monitor 2. You can set a maximum of 12 monitors as user monitors. This parameter is only available on an HOA keypad.
o1-26 (11AF) RUN	Custom Monitor 3	Sets Custom Monitor 3. You can set a maximum of 12 monitors as user monitors. This parameter is only available on an HOA keypad.
o1-27 (11B0) RUN	Custom Monitor 4	Sets Custom Monitor 4. You can set a maximum of 12 monitors as user monitors. This parameter is only available on an HOA keypad.
o1-28 (11B1) RUN	Custom Monitor 5	Sets Custom Monitor 5. You can set a maximum of 12 monitors as user monitors. This parameter is only available on an HOA keypad.
o1-29 (11B2) RUN	Custom Monitor 6	Sets Custom Monitor 6. You can set a maximum of 12 monitors as user monitors. This parameter is only available on an HOA keypad.
o1-30 (11B3) RUN	Custom Monitor 7	Sets Custom Monitor 7. You can set a maximum of 12 monitors as user monitors. This parameter is only available on an HOA keypad.

7 Parameter List

No. (Hex.)	Name	Description
01-31 (11B4) RUN	Custom Monitor 8	Sets Custom Monitor 8. You can set a maximum of 12 monitors as user monitors. This parameter is only available on an HOA keypad.
01-32 (11B5) RUN	Custom Monitor 9	Sets Custom Monitor 9. You can set a maximum of 12 monitors as user monitors. This parameter is only available on an HOA keypad.
01-33 (11B6) RUN	Custom Monitor 10	Sets Custom Monitor 10. You can set a maximum of 12 monitors as user monitors. This parameter is only available on an HOA keypad.
01-34 (11B7) RUN	Custom Monitor 11	Sets Custom Monitor 11. You can set a maximum of 12 monitors as user monitors. This parameter is only available on an HOA keypad.
01-35 (11B8) RUN	Custom Monitor 12	Sets Custom Monitor 12. You can set a maximum of 12 monitors as user monitors. This parameter is only available on an HOA keypad.
01-36 (11B9) RUN	LCD Backlight Brightness	Sets the intensity of the HOA keypad backlight.
01-37 (11BA) RUN	LCD Backlight ON/OFF Selection	Sets the automatic shut off function for the LCD backlight. 0 : OFF 1 : ON
01-38 (11BB) RUN	LCD Backlight Off-Delay	Sets the time until the LCD backlight automatically turns off.
01-39 (11BC) RUN	Show Initial Setup Screen	Sets the function to show the HOA keypad initial setup screen each time you energize the drive. This parameter is only available on an HOA keypad. 0 : No 1 : Yes
01-40 (11BD) RUN	Home Screen Display Selection	Sets the monitor display mode for the Home screen. This parameter is only available on an HOA keypad. 0 : Custom Monitor 1 : Bar Graph 2 : Analog Gauge 3 : Trend Plot
01-41 (11C1) RUN	1st Monitor Area Selection	Sets the horizontal range used to display the monitor set in 01-24 [Custom Monitor 1] as a bar graph. This parameter is only available on an HOA keypad. 0 : +/- Area (- 01-42 ~ 01-42) 1 : + Area (0 ~ 01-42)
01-42 (11C2) RUN	1st Monitor Area Setting	Sets the horizontal axis value used to display the monitor set in 01-24 [Custom Monitor 1] as a bar graph. This parameter is only available on an HOA keypad.
01-43 (11C3) RUN	2nd Monitor Area Selection	Selects the horizontal range used to display the monitor set in 01-25 [Custom Monitor 2] as a bar graph. This parameter is only available on an HOA keypad. 0 : +/- Area (- 01-44 ~ 01-44) 1 : + Area (0 ~ 01-44)
01-44 (11C4) RUN	2nd Monitor Area Setting	Sets the horizontal axis value used to display the monitor set in 01-25 [Custom Monitor 2] as a bar graph. This parameter is only available on an HOA keypad.
01-45 (11C5) RUN	3rd Monitor Area Selection	Sets the horizontal range used to display the monitor set in 01-26 [Custom Monitor 3] as a bar graph. This parameter is only available on an HOA keypad. 0 : +/- Area (- 01-46 ~ 01-46) 1 : + Area (0 ~ 01-46)
01-46 (11C6) RUN	3rd Monitor Area Setting	Sets the horizontal axis value used to display the monitor set in 01-26 [Custom Monitor 3] as a bar graph. This parameter is only available on an HOA keypad.
01-47 (11C7) RUN	Trend Plot 1 Scale Minimum Value	Sets the horizontal axis minimum value used to display the monitor set in 01-24 [Custom Monitor 1] as a trend plot. This parameter is only available on an HOA keypad.

No. (Hex.)	Name	Description
o1-48 (11C8) RUN	Trend Plot 1 Scale Maximum Value	Sets the horizontal axis maximum value used to display the monitor set in o1-24 [Custom Monitor 1] as a trend plot. This parameter is only available on an HOA keypad.
o1-49 (11C9) RUN	Trend Plot 2 Scale Minimum Value	Sets the horizontal axis minimum value used to display the monitor set in o1-25 [Custom Monitor 2] as a trend plot. This parameter is only available on an HOA keypad.
o1-50 (11CA) RUN	Trend Plot 2 Scale Maximum Value	Sets the horizontal axis maximum value used to display the monitor set in o1-25 [Custom Monitor 2] as a trend plot. This parameter is only available on an HOA keypad.
o1-51 (11CB) RUN	Trend Plot Time Scale Setting	Sets the time scale (horizontal axis) to display the trend plot. When you change this setting, the drive automatically adjusts the data sampling time. This parameter is only available on an HOA keypad.
o1-55 (11EE) RUN	Analog Gauge Area Selection	Sets the range used to display the monitor set in o1-24 [Custom Monitor 1] as an analog gauge. This parameter is only available on an HOA keypad. 0 : +/- Area (- o1-56 ~ o1-56) 1 : + Area (0 ~ o1-56)
o1-56 (11EF) RUN	Analog Gauge Area Setting	Sets the value used to display the monitor set in o1-24 [Custom Monitor 1] as an analog meter. This parameter is only available on an HOA keypad.
o1-58 (3125)	Motor Power Unit Selection	Sets the setting unit for parameters that set the motor rated power. 0 : kW 1 : HP
o1-80 (31BA)	Fault Screen Display	Sets a full-screen display message to show on the keypad when a fault or CPF occurs. 0 : OFF 1 : ON
o1-81 (31BB)	Alarm Screen Display	Sets a full-screen display message to show on the keypad when an alarm occurs. 0 : OFF 1 : ON
o1-82 (31BC)	Message Screen Display	Sets a full-screen display message to show on the keypad when a status message is active. 0 : OFF 1 : ON

■ o2: Keypad Operation

No. (Hex.)	Name	Description
o2-02 (0506)	OFF Key Function Selection	Sets the function to use  on the keypad to stop the drive when the Run command source for the drive is REMOTE (external) and not assigned to the keypad. 0 : Disabled 1 : Enabled
o2-03 (0507)	User Parameter Default Value	Sets the function to keep the settings of changed parameters as user parameter defaults to use during initialization. 0 : No change 1 : Set defaults 2 : Clear all
o2-04 (0508)	Drive Model (KVA) Selection	This parameter is automatically read from the connected drive. Do not change this parameter.
o2-05 (0509)	Home Mode Freq Ref Entry Mode	Sets the function that makes it necessary to push  to use the keypad to change the frequency reference value while in Drive Mode. 0 : ENTER Key Required 1 : Immediate / MOP-style
o2-06 (050A)	Keypad Disconnect Detection	Sets the function that stops the drive if you disconnect the keypad connection cable from the drive or if you damage the cable while the keypad is the Run command source. 0 : Disabled 1 : Enabled
o2-09 (050D)	Region Code	This parameter is read-only

7 Parameter List

No. (Hex.)	Name	Description
o2-19 (061F)	Parameter Write during Uv	Enables and disables the function to change parameter settings during a Uv [DC Bus Undervoltage] condition. 0 : Disabled 1 : Enabled
o2-24 (11FE)	LED Light Function Selection	Sets the function to show the LED status rings and keypad LED lamps. 0 : Enable Status Ring & Keypad LED 1 : LED Status Ring Disable 2 : Keypad LED Light Disable
o2-27 (1565)	bCE Detection Selection	Sets drive operation if the Bluetooth device is disconnected when you operate the drive in Bluetooth Mode. 0 : Ramp to Stop 1 : Coast to Stop 2 : Fast Stop (Use C1-09) 3 : Alarm Only 4 : No Alarm Display

■ o3: Copy Keypad Function

No. (Hex.)	Name	Description
o3-01 (0515)	Copy Keypad Function Selection	Sets the function that saves and copies drive parameters to a different drive with the keypad. 0 : Copy Select 1 : Backup (drive → keypad) 2 : Restore (keypad → drive) 3 : Verify (check for mismatch) 4 : Erase (backup data of keypad)
o3-02 (0516)	Copy Allowed Selection	Sets the copy function when o3-01 = 1 [Copy Keypad Function Selection = Backup (drive → keypad)]. 0 : Disabled 1 : Enabled
o3-04 (0B3E)	Select Backup/Restore Location	Sets the storage location for drive parameters when you back up and restore parameters. This parameter is only available on an HOA keypad. 0 : Memory Location 1 1 : Memory Location 2 2 : Memory Location 3 3 : Memory Location 4
o3-06 (0BDE)	Auto Parameter Backup Selection	Sets the function that automatically backs up parameters. This parameter is only available on an HOA keypad. 0 : Disabled 1 : Enabled
o3-07 (0BDF)	Auto Parameter Backup Interval	Sets the interval at which the automatic parameter backup function saves parameters from the drive to the keypad. 0 : Every 10 minutes 1 : Every 30 minutes 2 : Every 60 minutes 3 : Every 12 hours

■ o4: Maintenance Monitors

No. (Hex.)	Name	Description
o4-01 (050B)	Elapsed Operating Time Setting	Sets the initial value of the cumulative drive operation time in 10-hour units.
o4-02 (050C)	Elapsed Operating Time Selection	Sets the condition that counts the cumulative operation time. 0 : U4-01 Shows Total Power-up Time 1 : U4-01 Shows Total RUN Time
o4-03 (050E)	Fan Operation Time Setting	Sets the value from which to start the cumulative drive cooling fan operation time in 10-hour units.
o4-05 (051D)	Capacitor Maintenance Setting	Sets the U4-05 [CapacitorMaintenance] monitor value.
o4-07 (0523)	Softcharge Relay Maintenance Set	Sets the U4-06 [PreChargeRelayMainte] monitor value.
o4-09 (0525)	IGBT Maintenance Setting	Sets the U4-07 [IGBT Maintenance] monitor value.

No. (Hex.)	Name	Description
o4-11 (0510)	Fault Trace/History Init (U2/U3)	Resets the records of Monitors U2-xx [<i>Fault Trace</i>] and U3-xx [<i>Fault History</i>]. 0 : Disabled 1 : Enabled
o4-12 (0512)	kWh Monitor Initialization	Resets the monitor values for U4-10 [<i>kWh, Lower 4 Digits</i>] and U4-11 [<i>kWh, Upper 5 Digits</i>]. 0 : No Reset 1 : Reset
o4-13 (0528)	RUN Command Counter @ Initialize	Resets the monitor values for U4-02 [<i>Num of Run Commands</i>], U4-24 [<i>Number of Runs (Low)</i>], and U4-25 [<i>Number of Runs (High)</i>]. 0 : No Reset 1 : Reset
o4-22 (154F) RUN	Time Format	Sets the time display format. This parameter is only available on an HOA keypad. 0 : 24 Hour Clock 1 : 12 Hour Clock 2 : 12 Hour JP Clock
o4-23 (1550) RUN	Date Format	Sets the date display format. This parameter is only available on an HOA keypad. 0 : YYYY/MM/DD 1 : DD/MM/YYYY 2 : MM/DD/YYYY
o4-24 (310F) RUN	bAT Detection Selection	Sets operation when the drive detects bAT [<i>Keypad Battery Low Voltage</i>] and TiM [<i>Keypad Time Not Set</i>]. 0 : Disable 1 : Enable (Alarm Detected) 2 : Enable (Fault Detected)

■ o5: Log Function

No. (Hex.)	Name	Description
o5-01 (1551) RUN	Log Start/Stop Selection	Sets the data log function. This parameter is only available on an HOA keypad. 0 : OFF 1 : ON
o5-02 (1552) RUN	Log Sampling Interval	Sets the data log sampling cycle. This parameter is only available on an HOA keypad.
o5-03 (1553) RUN	Log Monitor Data 1	Sets the data log monitor. This parameter is only available on an HOA keypad.
o5-04 (1554) RUN	Log Monitor Data 2	Sets the data log monitor. This parameter is only available on an HOA keypad.
o5-05 (1555) RUN	Log Monitor Data 3	Sets the data log monitor. This parameter is only available on an HOA keypad.
o5-06 (1556) RUN	Log Monitor Data 4	Sets the data log monitor. This parameter is only available on an HOA keypad.
o5-07 (1557) RUN	Log Monitor Data 5	Sets the data log monitor. This parameter is only available on an HOA keypad.
o5-08 (1558) RUN	Log Monitor Data 6	Sets the data log monitor. This parameter is only available on an HOA keypad.
o5-09 (1559) RUN	Log Monitor Data 7	Sets the data log monitor. This parameter is only available on an HOA keypad.
o5-10 (155A) RUN	Log Monitor Data 8	Sets the data log monitor. This parameter is only available on an HOA keypad.

7 Parameter List

No. (Hex.)	Name	Description
o5-11 (155B) RUN	Log Monitor Data 9	Sets the data log monitor. This parameter is only available on an HOA keypad.
o5-12 (155C) RUN	Log Monitor Data 10	Sets the data log monitor. This parameter is only available on an HOA keypad.

◆ S: Special Applications

■ S1: Dynamic Noise Control

No. (Hex.)	Name	Description
S1-01 (3200) Expert	Dynamic Noise Control	Sets the function that decreases the output voltage in variable torque applications to decrease audible noise. 0 : Disabled 1 : Enabled
S1-02 (3201) Expert	Voltage Reduction Rate	Sets the rate at which the drive will decrease the output voltage as a percentage of the V/f pattern when operating with no load.
S1-03 (3202) Expert	Voltage Restoration Level	Sets the level at which the drive will start to restore the voltage as a percentage of the drive rated torque.
S1-04 (3203) Expert	Voltage Restoration Off Level	Sets the level at which voltage restoration for the V/f pattern is complete as a percentage of the drive rated torque. If the output is more than <i>S1-04</i> , the drive will control the voltage as specified by the V/f pattern setting.
S1-05 (3204) Expert	Volt Restore Sensitivity Time K	Sets the level of sensitivity of the output torque and LPF time constant for the voltage reduction rate. You can adjust the level of sensitivity with the load response.
S1-06 (3205) Expert	Volt Restore Impact Load Time K	Sets the voltage restoration time constant when you add an impact load.
S1-07 (324C) Expert	Output Phase Loss Level	Decreases the output phase loss level when Dynamic Noise control is active.

■ S3: PI2 Control

No. (Hex.)	Name	Description
S3-01 (321A)	PI2 Control Enable Selection	Sets when the PI2 Control function is enabled: 0 : Disabled 1 : Always 2 : Drive Running 3 : Motor Running
S3-02 (321B) RUN	PI2 Control Transducer Scale	Sets the full scale (10 V or 20 mA) output of the pressure transducer that is connected to the analog input terminals programmed for PI2 (Setpoint or Feedback).
S3-03 (321C) RUN	PI2 Control Decimal Place Pos	Sets the decimal place display for secondary PI units. 0 : No Decimal Places (XXXXX) 1 : One Decimal Places (XXXX.X) 2 : Two Decimal Places (XXX.XX) 3 : Three Decimal Places (XX.XXX)

No. (Hex.)	Name	Description
S3-04 (321D) RUN	PI2 Control Unit Selection	Sets the units displayed for the PI2 Control parameters and monitor. 0 : "WC: inches of water column 1 : PSI: pounds per square inch 2 : GPM: gallons/min 3 : °F: Fahrenheit 4 : ft ³ /min: cubic feet/min 5 : m ³ /h: cubic meters/hour 6 : L/h: liters/hour 7 : L/s: liters/sec 8 : bar: bar 9 : Pa: Pascal 10 : °C: Celsius 11 : m: meters 12 : ft: feet 13 : L/min: liters/min 14 : m ³ /min: cubic meters/min 15 : "Hg: Inch Mercury 16 : kPa: kilopascal 48 : %: Percent 49 : Custom(S3-18~20) 50 : None
S3-05 (321E) RUN	PI2 Control Setpoint	Sets the PI2 Control target setpoint.
S3-06 (321F) RUN	PI2 Control Proportional Gain	Sets the proportional gain of the PI2 Control. Set this parameter to 0.00 to disable proportional control.
S3-07 (3220) RUN	PI2 Control Integral Time	Sets the integral time for the suction pressure control. Set this parameter to 0.00 to disable the integrator.
S3-08 (3221) RUN	PI2 Control Integral Max Limit	Sets the maximum output possible from the integrator.
S3-09 (3222) RUN	PI2 Control Output Upper Limit	Sets the maximum output possible from the PI Auxiliary Control function.
S3-10 (3223) RUN	PI2 Control Output Lower Limit	Sets the minimum output possible from the PI Auxiliary Control function.
S3-11 (3224)	PI2 Control Output Level Sel	Sets the PI2 controller output direction. 0 : Direct Acting (Normal Output) 1 : Inverse Acting (Reverse Output)
S3-12 (3225) RUN	PI2 Control Disable Mode Sel	Sets what U5-20 [PI2 Control Output] will output when disabled. 0 : No Output (0%) 1 : Lower Limit (S3-10) 2 : Setpoint
S3-13 (3226) RUN	PI2 Control Low Feedback Lvl	Sets the secondary PI low feedback detection level.
S3-14 (3227) RUN	PI2 Control Low Feedback Time	Sets the secondary PI low feedback detection delay time in seconds.
S3-15 (3228) RUN	PI2 Control High Feedback Lvl	Sets the secondary PI high feedback detection level.
S3-16 (3229) RUN	PI2 Control High Feedback Time	Sets the secondary PI high feedback detection delay time in seconds.

7 Parameter List

No. (Hex.)	Name	Description
S3-17 (322A) RUN	PI2 Control Feedback Det Sel	Sets when the low and high feedback detection multifunction outputs (71h and 72h) for PI2 Control are active. 0 : While PI2 Control Enabled 1 : Always
S3-18 (322B) RUN	PI2 Control Custom Unit 1	Sets the first character of the PI2 Control custom unit display when $S3-04 = 49$ [PI2 Control Unit Selection = Custom(S3-18-20)].
S3-19 (322C) RUN	PI2 Control Custom Unit 2	Sets the second character of the PI2 Control custom unit display when $S3-04 = 49$ [PI2 Control Unit Selection = Custom(S3-18-20)].
S3-20 (322D) RUN	PI2 Control Custom Unit 3	Sets the third character of the PI2 Control custom unit display when $S3-04 = 49$ [PI2 Control Unit Selection = Custom(S3-18-20)].

■ S5: HAND/OFF/AUTO Operation

No. (Hex.)	Name	Description
S5-01 (322F)	HAND Frequency Reference Source	Sets the frequency reference source when HAND Mode is active. 0 : HAND Analog Input 1 : HAND Ref S5-05 or PID SP S5-06 2 : Set by b1-01
S5-02 (3230)	HAND/AUTO Switchover During Run	Sets the function to enable or disable switching between HAND and AUTO Mode during run. 0 : Disabled 1 : Enabled
S5-03 (3231) RUN	HAND Mode PID Selection	Sets the function to enable or disable PI function when HAND mode is active. 0 : Disabled 1 : Enabled
S5-05 (3233) RUN	HAND Frequency Reference	Sets the frequency reference when HAND Mode is active, PID is disabled and $S5-01 = 1$ [HAND Frequency Reference Source = HAND Ref S5-05 or PID SP S5-06].
S5-06 (3234) RUN	HAND Setpoint	Sets the System Setpoint when HAND Mode is active, PID is enabled and $S5-01 = 1$ [HAND Frequency Reference Source = HAND Ref S5-05 or PID SP S5-06].
S5-07 (3235)	Operation HAND Key	Sets the HAND key on the HOA keypad to let you switch between HAND Mode and AUTO Mode. 0 : Disabled 1 : Enabled
S5-08 (3D31) RUN	HAND Reference Prime Loss Level	Sets the level at which the drive will detect the Loss of Prime in the pump.

■ S6: Protection

No. (Hex.)	Name	Description
S6-01 (3236)	Emergency Override Speed	Sets the speed command for emergency override mode when $S6-02 = 0$ [Emergency Override Ref Selection = Use S6-01 Reference].
S6-02 (3237)	Emergency Override Ref Selection	Sets the Emergency Override Speed Source: 0 : Use S6-01 Reference 1 : Use Frequency Reference 2 : System PID Mode 3 : Independent PID Mode
S6-03 (323A)	EMOVR Independent PID Scale	Sets the scaling on the Emergency PID Feedback and Setpoint (if programmed) Analog Inputs.

No. (Hex.)	Name	Description
S6-04 (323B)	EMOVR Independent PID Unit	Sets the units displayed for S6-06 [EMOVR PID Setpoint] when S6-02 = 3 [Emergency Override Ref Selection = Independent PID Mode]. 0 : "WC: inches of water column 1 : PSI: pounds per square inch 2 : GPM: gallons/min 3 : °F: Fahrenheit 4 : ft³/min: cubic feet/min 5 : m³/h: cubic meters/hour 6 : L/h: liters/hour 7 : L/s: liters/sec 8 : bar: bar 9 : Pa: Pascal 10 : °C: Celsius 11 : m: meters 12 : ft: feet 13 : L/min: liters/min 14 : m³/min: cubic meters/min 15 : "Hg: Inch Mercury 16 : kPa: kilopascal 48 : %: Percent 49 : Custom(b5-68~70) 50 : None
S6-05 (323C)	EMOVR Independent PID Unit Digit	Sets the number of digits for S6-06 [EMOVR PID Setpoint] when S6-02 = 3 [Emergency Override Ref Selection = Independent PID Mode]. 0 : No Decimal Places (XXXXX) 1 : One Decimal Places (XXXX.X) 2 : Two Decimal Places (XXX.XX) 3 : Three Decimal Places (XX.XXX)
S6-06 (323D) RUN	EMOVR PID Setpoint	Sets the PID Setpoint when S6-02 = 3 [Emergency Override Ref Selection = Independent PID Mode].
S6-07 (323E)	EMOVR Fault Suppression Mode	Sets the drive to let Emergency Override disable faults during operation. 0 : Fault Suppression 1 : Test Mode
S6-08 (323F)	EMOVR Drive Enable Input Mode	Sets whether the Drive Enable Input (if programmed) must be inactive (drive is disabled) for Emergency Override to function. 0 : Drive Enable Status Ignored 1 : EMOVRun Only When Drive Disabled
S6-09 (3240)	Emergency Override Min Speed	When Emergency Override is active, the output frequency is lower-limited to this value.
S6-10 (3241)	Emergency Override Max Speed	When Emergency Override is active, the output frequency is upper-limited to this value.
S6-11 (3242) Expert	EMOVR Drive Protection Fault ON	Sets the bit to enable fault detection during Emergency Override. bit 0 : Uv1 - DC Bus Undervoltage bit 1 : CoF - Current Offset Fault bit 2 : Reserved bit 3 : Err - EEPROM Write Error bit 4 : Reserved bit 5 : Reserved bit 6 : oL2 - Drive Overload bit 7 : oPr - Operator Connection bit 8 : PF - Input Phase Loss bit 9 : Reserved bit 10 : Reserved bit 11 : oH - Heatsink Overheat bit 12 : oH1 - Heatsink Overheat bit 13 : OD - Output Disconnect bit 14 : FAn1 - Cooling Fan Fault bit 15 : ov2 - DC Bus Overvoltage 2

7 Parameter List

No. (Hex.)	Name	Description
S6-12 (3243) Expert	EMOVR Motor Protection Fault ON	Sets the bit to enable fault detection during Emergency Override. bit 0 : LF - Output Phase Loss bit 1 : LF2 - Output Current Imbalance bit 2 : oH3 - Motor Overheat PTC Input bit 3 : oH4 - Motor Overheat PTC Input bit 4 : Reserved bit 5 : oL1 - Motor Overload bit 6 : oL3 - Overtorque Detection 1 bit 7 : oL4 - Overtorque Detection 2 bit 8 : oL7 - High Slip Braking Overload bit 9 : Reserved bit 10 : UL3 - Undertorque Detection 1 bit 11 : UL4 - Undertorque Detection 2 bit 12 : UL6 - Motor Underload bit 13 : Reserved bit 14 : oS - Overspeed bit 15 : dEv: Speed Deviation
S6-13 (3244) Expert	EMOVR Option Fault ON	Sets the bit to enable fault detection during Emergency Override. bit 0 : bUS - Option Communication bit 1 : CE - Communication Error bit 2 : E5 - SI-T3 Watch Dog Timer bit 3 : EF0 - Option Card External Fault bit 4 : PE1 - PLC Fault 1 bit 5 : PE2 - PLC Fault 2 bit 6 : nSE - Node Setup Error bit 7 to 15 : Reserved
S6-14 (3245) Expert	EMOVR Application 1 Fault ON	Sets the bit to enable fault detection during Emergency Override. bit 0 : EFx - External Faults bit 1 : Reserved bit 2 : HLCE - High Level Communications Error bit 3 : bAT - HOA Keypad Battery Voltage Low bit 4 : TiM - Keypad Time Not Set bit 5 : bCE - Bluetooth Communication Fault bit 6 : Reserved bit 7 : Reserved bit 8 : Reserved bit 9 : MSL - Net Master Lost bit 10 : VLTS - Thermostat Fault bit 11 to 15 : Reserved
S6-16 (3247)	EMOVR Customer Safety Mode	Sets the status for the customer safety input (when programmed) that must occur for Emergency Override to function. 0 : Customer Safety Ignored 1 : EMOVRun Only When Safety OK 2 : EMOVRun Only When Safety NOT OK
S6-17 (3248)	EMOVR BAS Interlock Mode	Sets the status for the BAS Interlock input (when programmed) that must occur for Emergency Override to function. 0 : BAS Interlock Ignored 1 : EMOVRun Only When Interlock OK 2 : EMOVRun When Interlock NOT OK
S6-20 (324B) Expert	EMOVR Bypass Fault ON	Sets the bit to enable fault detection during Emergency Override. bit 0 : FB02 bit 1 : FB03 bit 2 : FB05 bit 3 : FB06 bit 4 : FB07 bit 5 : FB08 bit 6 : FB09 bit 7 : FB10 bit 8 : FB13 bit 9 : FB15 bit 10 : FB16 bit 11 : FB17 bit 12 : FB18
S6-23 (324E)	OV2 Detect Time	Sets the detection time of <i>ov2</i> [DC Bus Overvoltage 2] in 0.1 s increments.

◆ Y: Application Features

■ Y1: Application Basics

No. (Hex.)	Name	Description
Y1-04 (3C03) RUN	Sleep Wake-up Level	Sets the level that feedback must be less than for the time set in <i>Y1-05 [Sleep Wake-up Level Delay Time]</i> to start the system. This level also sets the wake up level when the drive is in Sleep Mode. When <i>Y1-04 < 0</i> , the feedback level must decrease this amount to less than the setpoint.
Y1-05 (3C04) RUN	Sleep Wake-up Level Delay Time	Sets the drive to start the System again when the feedback decreases to less than <i>Y1-04 [Sleep Wake-up Level]</i> for the time set in this parameter.
Y1-06 (3C05) RUN	Minimum Speed	Sets the minimum frequency at which the drive will run. The drive applies this setting to HAND and AUTO modes.
Y1-07 (3C06)	Minimum Speed Units	Sets the units and decimal place for <i>Y1-06 [Minimum Speed]</i> . 0 : Hz 1 : RPM
Y1-08 (3C07) RUN	Low Feedback Level	Sets the lower detection level for the PID feedback.
Y1-09 (3C08) RUN	Low Feedback Lvl Fault Dly Time	Sets the delay time for the drive to detect an <i>LFB [Low Feedback Sensed]</i> fault after the feedback level decreases to less than the value set in <i>Y1-08 [Low Feedback Level]</i> .
Y1-10 (3C09)	Low Feedback Selection	Sets the drive response when the feedback decreases to less than <i>Y1-08 [Low Feedback Level]</i> for longer than the time set in <i>Y1-09 [Low Feedback Lvl Fault Dly Time]</i> . 0 : Fault (and Digital Output) 1 : Alarm (and Digital Output) 2 : Digital Output Only
Y1-11 (3C0A) RUN	High Feedback Level	Sets the upper detection level for the PID feedback.
Y1-12 (3C0B) RUN	High Feedback Lvl Fault Dly Time	Sets the delay time between when the drive detects high feedback until the drive faults on an <i>HFB [High Feedback Sensed]</i> fault.
Y1-13 (3C0C)	High Feedback Selection	Sets the drive response when the feedback increased to more than <i>Y1-11 [High Feedback Level]</i> for longer than the time set in <i>Y1-12 [High Feedback Lvl Fault Dly Time]</i> . 0 : Fault (and Digital Output) 1 : Alarm (and Digital Output) 2 : Digital Output Only
Y1-14 (3C0D) RUN	Feedback Hysteresis Level	Sets the hysteresis level for low and high level feedback detection.
Y1-15 (3C0E) RUN	Maximum Setpoint Difference	Sets a percentage of difference between the setpoint and the feedback. The difference must be more than this value for the time set in <i>Y1-16 [Not Maintaining Setpoint Time]</i> to trigger the drive response set in <i>Y1-17 [Not Maintaining Setpoint Sel]</i> .
Y1-16 (3C0F) RUN	Not Maintaining Setpoint Time	Sets the delay time before a Setpoint Not Met condition occurs. The drive must detect the setpoint difference set in <i>Y1-15 [Maximum Setpoint Difference]</i> before the timer will start.
Y1-17 (3C10)	Not Maintaining Setpoint Sel	Sets the drive response when the feedback increases to more or decreases to less than the setpoint for more than the amount set in <i>Y1-15 [Maximum Setpoint Difference]</i> . 0 : Fault (and Digital Output) 1 : Alarm (and Digital Output) 2 : Digital Output Only
Y1-18 (3C11)	Prime Loss Detection Method	Sets the units and quantity that the drive will use to determine <i>LOP [Loss of Prime]</i> . 0 : Current (A) 1 : Power (kW) 2 : Torque (%)
Y1-19 (3C12) RUN	Prime Loss Level	Sets the level to detect the <i>LOP [Loss of Prime]</i> in the pump when in Auto or Sleep Boost Mode.

7 Parameter List

No. (Hex.)	Name	Description
Y1-20 (3C13) RUN	Prime Loss Time	Sets the delay time before the drive detects an <i>LOP [Loss of Prime]</i> condition. The timer starts when the drive detects the conditions in <i>Y1-18 [Prime Loss Detection Method]</i> and <i>Y1-19 [Prime Loss Level]</i> .
Y1-21 (3C14)	Prime Loss Activation Freq	Sets the frequency level above which the drive enables Loss of Prime detection.
Y1-22 (3C15)	Prime Loss Selection	Sets the drive response when the drive is in the Loss of Prime condition. 0 : Fault (and Digital Output) 1 : Alarm (and Digital Output) 2 : Digital Output Only
Y1-23 (3C16)	Prime Loss Max Restart Time	Sets the time in minutes that the drive will wait before it tries a restart after a restart fails or after it does not do a restart because of a fault.
Y1-40 (3C27) RUN	Maximum Speed	Sets the maximum speed.

■ Y2: PID Sleep and Protection

No. (Hex.)	Name	Description
Y2-01 (3C64)	Sleep Level Type	Sets the data source that the drive uses to know when to activate the Sleep Function. 0 : Output Frequency 1 : Output Current 2 : Feedback 3 : Output Speed (RPM) 5 : Output Frequency (non-PID)
Y2-02 (3C65) RUN	Sleep Level	Sets the level that the level type set in <i>Y2-01 [Sleep Level Type]</i> must be at for the time set in <i>Y2-03 [Sleep Delay Time]</i> for the drive to enter Sleep Mode.
Y2-03 (3C66) RUN	Sleep Delay Time	Sets the delay time before the drive enters Sleep Mode when the drive is at the sleep level set in <i>Y2-02 [Sleep Level]</i> .
Y2-04 (3C67) RUN	Sleep Activation Level	Sets the level above which the output frequency must increase to activate the Sleep Function when <i>Y2-01 = 0, 3, or 5 [Sleep Level Type = Output Frequency, Output Speed (RPM), or Output Frequency (non-PID)]</i> .
Y2-05 (3C68) RUN	Sleep Boost Level	Sets the quantity of boost that the drive applies to the setpoint before it goes to sleep.
Y2-06 (3C69) RUN	Sleep Boost Hold Time	Sets the length of time that the drive will keep the boosted pressure before it goes to sleep.
Y2-07 (3C6A) RUN	Sleep Boost Max Time	Sets the length of time that the system (feedback) has to reach the boosted setpoint. The system must reach the boosted setpoint in the time set in this parameter, or it will go to sleep.
Y2-08 (3C6B) RUN	Delta Feedback Drop Level	Sets the level of the PID Error (set-point minus feedback) to deactivate the Sleep Mode operation.
Y2-09 (3C6C) RUN	Feedback Drop Detection Time	Sets the time during which the software monitors the feedback to detect a flow/no-flow condition. Refer to <i>Y2-08 [Delta Feedback Drop Level]</i> for more information.
Y2-23 (3C7A) RUN	Anti-No-Flow Bandwidth	Sets the quantity of PI error bandwidth that the drive uses to detect an Anti- No-Flow condition. Set this parameter to 0.00% to disable Anti-No-Flow detection.
Y2-24 (3C7B) RUN	Anti-No-Flow Detection Time	Sets the time delay before the drive starts the increased deceleration rate after it detects Anti-No-Flow.
Y2-25 (3C7C) RUN	Anti-No-Flow Release Level	Sets the amount below the setpoint which the feedback must decrease before the drive will disengage Anti-No-Flow and return to normal PI operation.

■ Y4: Application Advanced

No. (Hex.)	Name	Description
Y4-01 (3CFA) RUN	Pre-Charge Level	Sets the level at which the drive will activate the pre-charge function when the drive is running at the frequency set in Y4-02 [Pre-Charge Frequency].
Y4-02 (3CFB) RUN	Pre-Charge Frequency	Sets the frequency at which the pre-charge function will operate.
Y4-03 (3CFC) RUN	Pre-Charge Time	Sets the length of time that the Pre-Charge function will run.
Y4-05 (3CFE) RUN	Pre-Charge Loss of Prime Level	Sets the level at which the drive will detect loss of prime in the pump.
Y4-11 (3D04) RUN	Thrust Acceleration Time	Sets the time at which the drive output frequency will ramp up to the reference frequency set in Y4-12 [Thrust Frequency].
Y4-12 (3D05) RUN	Thrust Frequency	Sets the Thrust Frequency that the drive will use to know which acceleration and deceleration time to use. The drive will accelerate to this frequency in the Y4-11 [Thrust Acceleration Time] time and decelerate from this frequency in the Y4-13 [Thrust Deceleration Time] time.
Y4-13 (3D06) RUN	Thrust Deceleration Time	Sets the length of time necessary for the drive to go from the Thrust Frequency in Y4-12 [Thrust Frequency] to stop when Thrust Mode is active.
Y4-18 (3D0B) RUN	Differential Level	Sets the maximum difference that the drive will allow when it subtracts the Differential Feedback from the Primary PID Feedback.
Y4-19 (3D0C) RUN	Differential Lvl Detection Time	Sets the length of time that the difference between PID Feedback and the Differential Feedback must be more than Y4-18 [Differential Level] before the drive will respond as specified by Y4-20 [Differential Level Detection Selection].
Y4-20 (3D0D) RUN	Differential Level Detection Sel	Sets the drive response during a Differential Level Detected condition. 0 : Fault (and Digital Out) 1 : Alarm (and Digital Out) 2 : Digital Out Only
Y4-22 (3D0F) RUN	Low City On-Delay Time	Sets the length of time that the drive will wait to stop when the drive detects a Low City Pressure condition.
Y4-23 (3D10) RUN	Low City Off-Delay Time	Sets the length of time that the drive will wait to start again after you clear a Low City Pressure condition.
Y4-24 (3D11) RUN	Low City Alarm Text	Sets the alarm message to show on the keypad when the drive detects a Low City Pressure condition. 0 : Low City Pressure 1 : Low Suction Pressure 2 : Low Water in Tank
Y4-36 (3D1D) RUN	Pressure Reached Exit Conditions	Sets how the digital output responds to Feedback changes after it activates. 0 : Hysteresis Above & Below 1 : Hysteresis 1-Way
Y4-37 (3D1E) RUN	Pressure Reached Hysteresis Lvl	Sets the hysteresis level that will cause the drive to exit the Pressure Reached condition.
Y4-38 (3D1F) RUN	Pressure Reached On Delay Time	Sets the length of time that the drive will wait before it activates the Pressure Reached condition.
Y4-39 (3D20) RUN	Pressure Reached Off Delay Time	Sets the length of time that the drive will wait before it deactivates the Pressure Reached condition.

7 Parameter List

No. (Hex.)	Name	Description
Y4-40 (3D21) RUN	Pressure Reached Detection Sel	Sets the drive status that triggers the Pressure Reached Detection digital output. 0 : Always 1 : Drive Running 2 : Run Command
Y4-41 (3D22) RUN	Diff Lvl Src Fdbk Backup Select	Sets the function to enable or disable <i>Differential Level Source</i> [H3-xx = 2D] as the backup transducer if there is a failure with the primary PID Feedback transducer [H3-xx = B] and the PID Feedback Backup transducer [H3-xx = 24] is not available. 0 : Disabled 1 : Enabled
Y4-42 (3D23)	Output Disconnect Detection Sel	This parameter applies only when in Drive Mode. It sets the drive response if the connection between the drive and the motor is disconnected. 0 : Disabled 1 : Alarm - Speed Search 2 : Alarm - Start at Zero 3 : Fault
Y4-43 (3D24)	Output Disconnect Inject Current	Sets the level of DC injection current during output disconnect as a percentage of the drive rated current.

■ YA: Preset Setpoint

No. (Hex.)	Name	Description
YA-01 (3E58) RUN	Setpoint 1	Sets the PID Setpoint when $b1-01 = 0$ [Frequency Reference Selection 1 = Keypad or Multi-Speed Selection].
YA-02 (3E59) RUN	Setpoint 2	Sets the PID Setpoint as specified by the Multi-Setpoint digital inputs.
YA-03 (3E5A) RUN	Setpoint 3	Sets the PID Setpoint as specified by the Multi-Setpoint digital inputs.
YA-04 (3E5B) RUN	Setpoint 4	Sets the PID Setpoint as specified by the Multi-Setpoint digital inputs.

■ YC: Foldback Features

No. (Hex.)	Name	Description
YC-01 (3EBC)	Output Current Limit Select	Sets the function to enable or disable the output current regulator. 0 : Disabled 1 : Enabled
YC-02 (3EBD) RUN	Current Limit	Sets the current limit.
YC-10 (3EC5)	Single Phase Foldback Sel	Sets the function to enable or disable the single phase ripple regulator. 0 : Disabled 1 : Enabled
YC-11 (3EC6)	Ripple Regulator Setpoint	Sets the ripple regulator setpoint as a percentage of the maximum amount of ripple permitted before the drive detects a <i>PF</i> [Input Phase Loss] fault.

■ YF: PI Auxiliary Control

No. (Hex.)	Name	Description
YF-01 (3F50) RUN	PI Aux Control Selection	Sets the PI Auxiliary Control function. 0 : Disabled 1 : Enabled
YF-02 (3F51) RUN	PI Aux Control Transducer Scale	Sets the full scale (10 V or 20 mA) output of the pressure transducer connected to the analog input terminal programmed for H3-xx = 27 [PI Aux Control Feedback Level].
YF-03 (3F52) RUN	PI Aux Control Setpoint	Sets the level to which the drive will try to regulate.
YF-04 (3F53) RUN	PI Aux Control Minimum Level	Sets the level below which the drive must be for longer than YF-05 [PI Aux Control Sleep Delay Time] before the drive goes to sleep and turns off all lag pumps.
YF-05 (3F54) RUN	PI Aux Control Sleep Delay Time	Sets the length of time that the drive will delay before it goes to sleep after the level is less than YF-04 [PI Aux Control Minimum Level] (when YF-23 = 1 [PI Aux Ctrl Output Level Select = Inverse Acting]) or more than YF-24 [PI Auxiliary Ctrl Maximum Level] (when YF-23 = 0 [Direct Acting]).
YF-06 (3F55) RUN	PI Aux Control Wake-up Level	Sets the level to wake up the drive when the drive after YF-04 [PI Aux Control Minimum Level] or YF-24 [PI Auxiliary Ctrl Maximum Level] put the drive to sleep.
YF-07 (3F56)	PI Aux Control Wake-up Time	Sets the time to wake up the drive when the drive after YF-04 [PI Aux Control Minimum Level] or YF-24 [PI Auxiliary Ctrl Maximum Level] put the drive to sleep.
YF-08 (3F57) RUN	PI Aux Control Minimum Speed	Sets the minimum speed at which the drive can run when the PI Auxiliary Control has an effect on the output speed.
YF-09 (3F58) RUN	PI Aux Control Low Level Detect	Sets the level below which the drive must be for longer than YF-10 [PI Aux Control Low Lvl Det Time] to respond as specified by YF-11 [PI Aux Control Low Level Det Sel].
YF-10 (3F59) RUN	PI Aux Low Level Detection Time	Sets the length of time that the PI Aux Feedback must be less than YF-09 [PI Aux Control Low Lvl Detection] to trigger a drive response when YF-11 = 2 and 3 [PI Aux Control Low Level Det Sel = Fault and Auto-Restart (time set by YF-15)].
YF-11 (3F5A)	PI Aux Control Low Level Det Sel	Sets drive response when the PI Aux Feedback decreases to less than YF-09 [PI Aux Control Low Lvl Detection] for longer than YF-10 [PI Aux Control Low Lvl Det Time]. 0 : No Display 1 : Alarm Only 2 : Fault 3 : Auto-Restart (time set by YF-15)
YF-12 (3F5B) RUN	PI Aux Control High Level Detect	Sets the value above which the level must be for longer than YF-13 [PI Aux High Level Detection Time] to respond as specified by YF-14 [PI Aux Hi Level Detection Select].
YF-13 (3F5C) RUN	PI Aux High Level Detection Time	Sets the length of time that the level must be more than YF-12 [PI Aux Control High Level Detect] before the drive will respond when YF-14 = 2, 3 [PI Aux Hi Level Detection Select].
YF-14 (3F5D)	PI Aux Control Hi Level Det Sel	Sets the drive response when the PI Aux Feedback increases to more than the YF-12 [PI Aux Control High Level Detect] level for longer than the time set in YF-13 [PI Aux High Level Detection Time]. 0 : NoDisplay (Digital Output Only) 1 : Alarm Only 2 : Fault 3 : Auto-Restart (time set by YF-15)
YF-15 (3F5E)	PI Aux Level Detect Restart Time	Sets the length of time the drive will wait before it tries an Auto-Restart of LOAUX [Low PI Aux Feedback Level] or HLAUX [High PI Aux Feedback Level] fault.
YF-16 (3F5F) RUN	PI Auxiliary Control P Gain	Sets the proportional gain for the suction pressure control.
YF-17 (3F60) RUN	PI Auxiliary Control I Time	Sets the integral time for the suction pressure control.

7 Parameter List

No. (Hex.)	Name	Description
YF-18 (3F61)	PI Aux Control Detect Time Unit	Sets the time unit for <i>YF-10 [PI Aux Control Low Lvl Det Time]</i> and <i>YF-13 [PI Aux High Level Detection Time]</i> . 0 : Minutes (min) 1 : Seconds (sec)
YF-19 (3F62)	PI Aux Ctrl Feedback WireBreak	Sets how the analog input selected for PI Aux Feedback will respond when it is programmed to receive a 4 mA to 20 mA signal and the signal is lost. 0 : Disabled 1 : Alarm Only 2 : Fault (no retry, coast to stop)
YF-20 (3F63)	PI Aux Main PI Speed Control	Sets if the PI Auxiliary Controller has an effect on output speed. 0 : Disabled 1 : Enabled
YF-21 (3F64)	PI Aux Ctrl Level Unit Selection	Set the units shown for the PI Aux Level parameters and monitors. 0 : "WC: inches of water column 1 : PSI: pounds per square inch 2 : GPM: gallons/min 3 : °F: Fahrenheit 4 : ft ³ /min: cubic feet/min 5 : m ³ /h: cubic meters/hour 6 : L/h: liters/hour 7 : L/s: liters/sec 8 : bar: bar 9 : Pa: Pascal 10 : °C: Celsius 11 : m: meters 12 : ft: feet 13 : L/min: liters/min 14 : m ³ /min: cubic meters/min 15 : "Hg: Inch Mercury 16 : kPa: kilopascal 48 : %: Percent 49 : Custom (YF-32 ~ 34) 50 : None
YF-22 (3F65)	PI Aux Level Decimal Place Pos	Sets the number of decimal places for the PI Aux Level parameters and monitors. 0 : No Decimal Places (XXXXX) 1 : One Decimal Places (XXXX.X) 2 : Two Decimal Places (XXX.XX) 3 : Three Decimal Places (XX.XXX)
YF-23 (3F66)	PI Aux Ctrl Output Level Select	Sets the PI Auxiliary Controller to be Direct-acting or Inverse-acting. 0 : Direct Acting 1 : Inverse Acting
YF-24 (3F67) RUN	PI Auxiliary Ctrl Maximum Level	Sets the maximum level for PI Auxiliary Control. When the level is more than this setting for longer than <i>YF-05 [PI Aux Control Sleep Delay Time]</i> , the drive will go to sleep and turn off all lag drives.
YF-25 (3F68) RUN	PI Aux Control Activation Level	Sets the level to activate the PI Auxiliary Control.
YF-26 (3F69) RUN	PI Aux Control Activation Delay	Sets the delay time to activate the PI Auxiliary Control.
YF-32 (3F6F)	PI Aux Custom Unit Character 1	Sets the first character of the PI Aux custom unit display when <i>YF-21 = 49 [PI Aux Ctrl Level Unit Selection = Custom (YF-32 ~ 34)]</i> .
YF-33 (3F70)	PI Aux Custom Unit Character 2	Sets the second character of the PI Aux custom unit display when <i>YF-21 = 49 [PI Aux Ctrl Level Unit Selection = Custom (YF-32 ~ 34)]</i> .
YF-34 (3F71)	PI Aux Custom Unit Character 3	Sets the third character of the PI Aux custom unit display when <i>YF-21 = 49 [PI Aux Ctrl Level Unit Selection = Custom (YF-32 ~ 34)]</i> .
YF-35 (3F72)	PI Aux Minimum Transducer Scale	Sets the minimum scale output of the pressure transducer that is connected to the terminal set for <i>H3-xx = 27 [MFAI Function Selection = PI Auxiliary Control Feedback]</i> .
YF-36 (3F73) RUN	PI Aux Lo Hi Lvl Det Hysteresis	Sets the Hysteresis Level used for low and high level detection.

◆ Z: Bypass Parameters

■ Z1: Bypass Control System

No. (Hex.)	Name	Description
Z1-05 (85CA)	Auto Transfer To Bypass	When the drive is running and a there is a drive fault, operation will switch to Bypass Mode. When you remove the fault, the operation will go back to Drive Mode 0 : Disabled 1 : Enabled
Z1-06 (85CB)	Power Up Mode	Sets the mode of bypass control at power-up. 0 : OFF-DRIVE 1 : AUTO-DRIVE 3 : AUTO-BYPASS 5 : Powerup HOA Memory
Z1-10 (85CF)	Emergency Override Transfer	Enables and disables the function to auto transfer to EMOV bypass if the drive declares a fault when the bypass is running in EMOV drive. 0 : Disabled 1 : Enabled
Z1-11 (85D0)	Motor AND/OR Function	- 0 : Disabled 1 : Always Motor 1 2 : Always Motor 2 3 : Always Motor 1 AND 2 4 : OR in HAND and AUTO 5 : MOTOR 1 in HAND OR in AUTO 6 : MOTOR 2 in HAND OR in AUTO 7 : AND/OR in HAND and AUTO 8 : MOTOR 1 in HAND AND/OR in AUTO 9 : MOTOR 2 in HAND AND/OR in AUTO 10 : MOTOR 1,2 in HAND AND/OR in AUTO
Z1-12 (85D1)	Run Delay Time	When the Run command is issued, the drive will run at speed set in Z1-14 [Run Delay Frequency Reference]. After the time set in this parameter, the frequency reference will return to its programmed source (b1-01 or HAND frequency reference).
Z1-13 (85D2)	Pre Interlock Run Select	Determines if the drive will run at a preset speed when the BAS Interlock Digital Input is open and a Run command is present. 0 : Disabled 1 : Enabled (DRIVE Mode) 1 : Enabled (BYPASS Mode)
Z1-14 (85D3)	Run Delay Frequency Reference	Sets the frequency that the bypass uses when it delays the Run command.
Z1-15 (85D4)	Interlock Wait Time	When you enter a Run command, it asserts the damper actuator output. When you program an input for Interlock and the time set to this parameter expires before the Interlock input activates, it will trigger a fault.
Z1-16 (85D5)	Energy Savings Mode	Enables the contactor-based Energy Savings function and determines which conditions must be met before the bypass will enter into Energy Savings Mode. 0 : Disabled 1 : Frequency 2 : Frequency + Current
Z1-17 (85D6)	Energy Savings Frequency Ref	Both frequency reference and output frequency must be within the window defined by this parameter, Z1-19 [Energy Savings Fref Deadbnad], and Z1-20 [Energy Savings Out Freq Deadband] for Energy Savings operation.
Z1-18 (85D7)	Energy Savings Output Cur Level	Drive output current must be in the window defined by this parameter and Z1-21 [Energy Savings Out Cur Deadband] to enter Energy Savings Mode.
Z1-19 (85D8)	Energy Savings Fref Deadband	Used with Z1-17 [Energy Savings Frequency Ref] to set when to enter and exit Energy Savings Mode.
Z1-20 (85D9)	Energy Savings Out Freq Deadband	Used with Z1-17 [Energy Savings Frequency Ref] to set when to enter Energy Savings Mode.
Z1-21 (85DA)	Energy Savings Out Cur Deadband	Used with Z1-18 [Energy Savings Output Cur Level] to set when to enter Energy Savings Mode.
Z1-22 (85DB)	Energy Savings Mode Time	Sets the length of time that all conditions must be in the set limits before transferring into Energy Savings Mode.
Z1-23 (85DC)	Energy Savings Freq Ref Increase	Sets the value to add to the drive Frequency Reference when transferring to Bypass Energy Savings Mode.

7 Parameter List

No. (Hex.)	Name	Description
Z1-24 (85DD)	Contactors Open Delay	Sets the time to delay after commanding the drive output contactor K2 or bypass contactor K3 or 2-Motor OR/AND contactors K4 and K5 to open to let the contacts open.
Z1-25 (85DE)	Contactors Close Delay	Sets the time to delay after commanding the drive output contactor K2 or bypass contactor K3 or 2-Motor OR/AND contactors K4 and K5 to close to let the contacts close.
Z1-27 (85E0)	Brownout Voltage Level	Sets the voltage level below which is a brownout condition.
Z1-28 (85E1)	Brownout Detection Time	Sets the length of time that the Bypass voltage must be less than the Brownout Voltage Level before the Bypass will trigger a Brownout fault.
Z1-29 (85E2)	Blackout Voltage Level	Sets the voltage level to determine a blackout condition. Use Z1-60 [Blackout Operation Select] to set power blackout behavior.
Z1-31 (85E4)	Loss of Load Detection Select	Sets the function to detect loss of load. 0 : Disabled 1 : Enable and Fault 2 : Enable and Alarm
Z1-32 (85E5)	Loss of Load Drive Frequency	Sets the value to which the drive output frequency must be equal to or more than for the drive to detect a loss of load.
Z1-33 (85E6)	Loss of Load Drive Out Current	For Drive Mode only, the drive output current must be less than this level to detect a Loss of Load condition.
Z1-34 (85E7)	Loss of Load Drive Det Time	The loss of load conditions must be met for the length of time in this parameter before the bypass will detect a loss of load in Drive Mode.
Z1-35 (85E8)	Loss of Load Bypass Current	For Bypass Mode only, the motor current must be less than this level to detect a Loss of Load condition.
Z1-36 (85E9)	Loss of Load Bypass Det Time	The motor current must be less than the value set in Z1-35 [Loss of Load Bypass Current] for the length of time set in this parameter before the bypass will detect a loss of load in Bypass Mode.
Z1-39 (85EC)	Drive/Bypass Source Select	Sets the function to select the Drive or the Bypass as the source of Drive/Bypass Mode selection. 0 : Keypad 1 : Digital Input 2 : Serial Communications 3 : Option PCB
Z1-40 (85ED)	Auto Transfer Delay Time	When you enable Auto Transfer and the bypass detects a drive fault, the bypass controller will wait for the length of time set in this parameter before it switches to bypass.
Z1-42 (85EF)	Soft Starter Selection	This parameter is normally set at the factory and does not require adjustment. Sets when there is a soft starter used in bypass operation and when the soft starter will be used for a "soft stop". 0 : Not Installed – Contactor Only 1 : Installed – Coast To Stop 2 : Installed – Ramp To Stop
Z1-43 (85F0)	Soft Starter Delay Timer	This parameter is normally set at the factory and does not require adjustment. Sets the delay time between closing contactor K3 and energizing the soft starter.
Z1-44 (85F1)	Soft Starter Rampdown Timeout	Sets the maximum wait time for the current to be less than 5% of E2-01 after removing the soft starter Run command.
Z1-50 (85F7)	Bypass Input Phase Loss Level	The bypass measures the current unbalance between phases to detect input phase loss. Usually it is not necessary to change this parameter.
Z1-51 (85F8)	Bypass Input Phase Loss Delay	Sets the trip time for an input phase loss condition in Bypass Mode.
Z1-52 (85F9)	Input Phase Rotation Detection	Sets bypass response when the Bypass Mode phase rotation is incorrect. 0 : Disabled 1 : Alarm 2 : Fault
Z1-53 (85FA)	Load Verify Detection	Enables and disables verification that the motor is running when commanded to run. 0 : Disabled 1 : Enabled
Z1-55 (85FC)	Welded Contactor Detection	Enables and disables detection of K3 "welded contactor" condition. 0 : Disabled 1 : Enabled

No. (Hex.)	Name	Description
Z1-56 (85FD) RUN	Test Mode	Sets the behavior of the drive input contactor K1 during Bypass Mode. 0 : Drive Power Off during Bypass 1 : Drive Power On during Bypass
Z1-60 (8601)	Blackout Operation Select	Sets bypass behavior when contactor voltage is less than Z1-29 [Blackout Voltage Level]. 0 : Fault 1 : Restart Delay with Speed Search 2 : Restart Delay from Zero Speed 3 : Disabled
Z1-61 (8602)	Power Loss Restart Delay Time	Sets the time delay for restart. This parameter works together Z1-60 [Blackout Operation Select]
Z1-70 (860B)	Green Contactor Mode	Green Contactor Mode opens the output and motor contactors when the bypass unit is idle and does not have a Run command. 0 : Disabled 1 : Enabled
Z1-94 (8623) Expert	Current Transformer Turns	This parameter will indicate to the bypass controller how many times the motor leads pass through bypass current transformers. This parameter is typically set at the Yaskawa factory and does not require adjustment. 0 : Automatic 1 : Force 1 Turn 2 : Force 2 Turns
Z1-98 (8627) Expert	Minimum Drive SW Ver	Only change this parameter under the guidance of Yaskawa technical support (1-800-YASKAWA). If you change this parameter incorrectly, it can cause incorrect operation of the bypass system. Bypass SW VST800560 : Default: 1012
Z1-99 (8628) Expert	Maximum Drive SW Ver	Only change this parameter under the guidance of Yaskawa technical support (1-800-YASKAWA). If you change this parameter incorrectly, it can cause incorrect operation of the bypass system. Bypass SW VST800560 : Default: 1012

■ Z2: Bypass Control Input/Output

No. (Hex.)	Name	Description
Z2-01 (8563)	Digital Input 1 Function (TB2-1)	Sets the function for bypass digital input 1.
Z2-02 (8564)	Digital Input 2 Function (TB2-2)	Sets the function for bypass digital input 2.
Z2-03 (8565)	Digital Input 3 Function (TB2-3)	Sets the function for bypass digital input 3.
Z2-04 (8566)	Digital Input 4 Function (TB2-4)	Sets the function for bypass digital input 4.
Z2-05 (8567)	Digital Input 5 Function (TB2-5)	Sets the function for bypass digital input 5.
Z2-06 (8568)	Digital Input 6 Function (TB2-6)	Sets the function for bypass digital input 6.
Z2-07 (8569)	Digital Input 7 Function (TB2-7)	Sets the function for bypass digital input 7.
Z2-08 (856A)	Digital Input 8 Function (TB2-8)	Sets the function for bypass digital input 8.
Z2-09 (856B)	Digital Input 1 Invert Select	Inverts the output of the function selected in Digital Input 1. 0 : Normal (Non-inverted) 1 : Inverted
Z2-10 (856C)	Digital Input 2 Invert Select	Inverts the output of the function selected in Digital Input 2. 0 : Normal (Non-inverted) 1 : Inverted
Z2-11 (856D)	Digital Input 3 Invert Select	Inverts the output of the function selected in Digital Input 3. 0 : Normal (Non-inverted) 1 : Inverted
Z2-12 (856E)	Digital Input 4 Invert Select	Inverts the output of the function selected in Digital Input 4. 0 : Normal (Non-inverted) 1 : Inverted

7 Parameter List

No. (Hex.)	Name	Description
Z2-13 (856F)	Digital Input 5 Invert Select	Inverts the output of the function selected in Digital Input 5. 0 : Normal (Non-inverted) 1 : Inverted
Z2-14 (8570)	Digital Input 6 Invert Select	Inverts the output of the function selected in Digital Input 6. 0 : Normal (Non-inverted) 1 : Inverted
Z2-15 (8571)	Digital Input 7 Invert Select	Inverts the output of the function selected in Digital Input 7. 0 : Normal (Non-inverted) 1 : Inverted
Z2-16 (8572)	Digital Input 8 Invert Select	Inverts the output of the function selected in Digital Input 8. 0 : Normal (Non-inverted) 1 : Inverted
Z2-23 (8579)	Digital Output 7 (TB1 1~3)	Sets the function for bypass digital output 7.
Z2-24 (857A)	Digital Output 8 (TB1 4~6)	Sets the function for bypass digital output 8.
Z2-25 (857B)	Digital Output 9 (TB1 7~9)	Sets the function for bypass digital output 9.
Z2-26 (857C)	Digital Output 10 (TB1 10~12)	Sets the function for bypass digital output 10.
Z2-30 (8580)	Analog Input Signal Level Select	Sets the input signal level for the analog input on the bypass control board (A2) Terminal TB4-2. 0 : 0 to 10V (Lower Limit at 0) 2 : 4 to 20 mA 3 : 0 to 20 mA
Z2-32 (8582)	Analog Input Gain Setting	Sets the gain of the analog signal input to the analog input on the bypass control board (A2) Terminal TB4-2.
Z2-33 (8583)	Analog Input Bias Setting	Sets the bias of the analog signal input to the analog input on the bypass control board (A2) Terminal TB4-2.

■ Z2-xx: Digital Input Setting Values

Setting Value	Function
0	Not Used
1	Drive S1 Passthrough
2	Drive S2 Passthrough
3	Drive S3 Passthrough
4	Drive S4 Passthrough
5	Drive S5 Passthrough
6	Drive S6 Passthrough
7	Drive S7 Passthrough
8	Drive S8 Passthrough
21	Run (AUTO)
22	Run Enable - Safety (NC)
23	Run Interlock (BAS)
24	Remote Transfer to Bypass
25	Emergency Override Bypass
26	Emergency Override Drive (FWD)
27	Motor OR Select
28	Motor AND Select
29	External Overload Motor 1 (NC)

Setting Value	Function
30	External Overload Motor 2 (NC)
31	HAND Select
32	AUTO Select
33	Drive/Bypass Select
34	Fault Reset
35	External Fault (EF0)
36	External Fault (EFB)
37	Run Reverse (AUTO)
38	Fire Stat Switch (NC)
39	Freeze Stat Switch (NC)
40	Smoke Alarm (NC)
41	OverPressure Switch (NC)
42	Low Suction Switch (NC)
43	Vibration Switch (NC)
44	Emergency Override Drive (REV)
45	Serial Hardware Test (RS-485)
46	Low City Pressure
47	Motor Preheat
48	Low Water (NC)
49	High Water (NC)

■ Z2-xx: Digital Output Setting Values

Setting Value	Function
0	Serial Communication Control
1	K1 Drive Input Contactor
2	K2 Drive Output Contactor
3	K3 Bypass Contactor
4	K4 Motor 1 Contactor
5	K5 Motor 2 Contactor
6	READY
7	RUN Active
8	Drive RUN active
9	Bypass RUN active
10	HAND mode Active
11	OFF mode Active
12	Auto mode Active
13	Drive Mode Selected
14	Bypass Mode Selected
15	Fault Active
16	Drive Fault Active
17	Bypass Fault Active
18	Auto Transfer Active
19	Serial Run Active

7 Parameter List

Setting Value	Function
20	Damper Actuator Output
21	ON Always
22	Loss of Load Detected
23	Run Verify Active
24	Soft Starter Run Command
25	Safeties Closed
26	Mirror FP605 M1-M2
27	Mirror FP605 M3-M4
28	Mirror FP605 MD-ME-MF
99	Not Used

■ Z3: Bypass Control Serial Comm

No. (Hex.)	Name	Description
Z3-12 (850B)	Network Digital Inputs	Enables and disables control of the physical digital inputs of the bypass and the drive over a network. When this is enabled, it is not necessary to wire to the physical digital input. 0 : Disabled 1 : Enabled
Z3-13 (850C)	BACnet Register Retention	Sets what to restore when you lose power then reapply power. 0 : Disabled 1 : Restore Frequency Reference Only 2 : Restore Commands Only 3 : Restore Commands and Freq Ref
Z3-16 (850F)	Apogee Run Enable LDO35	This parameter is applicable only when $H5-08 = 2$ [Communication Protocol Selection = Apogee/PI]. 0 : Disabled 1 : Enabled

◆ U: Monitors

■ U1: Operation Status Monitors

No. (Hex.)	Name	Description
U1-01 (0040)	Frequency Reference (AI)	Shows the frequency reference value. Parameter $o1-03$ [Keypad Display Unit Selection] sets the display units.
U1-02 (0041)	Output Frequency	Shows the output frequency. Parameter $o1-03$ [Keypad Display Unit Selection] sets the display units.
U1-03 (0042)	Output Current	Shows the drive unit output current.
U1-04 (0043)	Control Method	Shows the drive control method. 0 : V/f Control
U1-06 (0045)	Output Voltage Ref	Shows the output voltage reference.
U1-07 (0046)	DC Bus Voltage	Shows the DC bus voltage.
U1-08 (0047)	Output Power	Shows the internally-calculated output power.

No. (Hex.)	Name	Description
U1-10 (0049)	Input Terminal Status	Shows the status of the MFDI terminal where 1 = (ON) and 0 = (OFF). bit0 : Terminal S1 (MFDI 1) bit1 : Terminal S2 (MFDI 2) bit2 : Terminal S3 (MFDI 3) bit3 : Terminal S4 (MFDI 4) bit4 : Terminal S5 (MFDI 5) bit5 : Terminal S6 (MFDI 6) bit6 : Terminal S7 (MFDI 7) bit7 : Terminal S8 (MFDI 8)
U1-11 (004A)	Output Terminal Status	Shows the status of the MFDO terminal where 1 = (ON) and 0 = (OFF). bit 0 : Terminals M1-M2 bit 1 : Terminals M3-M4 bit 2 : Terminals MD-ME-MF bit 3 : Not used (normal value of 0). bit 4 : Not used (normal value of 0). bit 5 : Not used (normal value of 0). bit 6 : Not used (normal value of 0). bit 7 : Fault relay MA/MB-MC
U1-12 (004B)	Drive Status	Shows drive status where 1 = ON and 0 = OFF. bit0 : During Run bit1 : During zero-speed bit2 : During reverse bit3 : During fault reset signal input bit4 : During speed agreement bit5 : Drive ready bit6 : During minor fault detection bit7 : During fault detection
U1-13 (004E)	Terminal A1 Level	Shows the signal level of terminal A1.
U1-14 (004F)	Terminal A2 Level	Shows the signal level of terminal A2.
U1-15 (0050)	Terminal A3 Level	Shows the signal level of terminal A3.
U1-16 (0053)	SFS Output Frequency	Shows the output frequency after soft start. Shows the frequency with acceleration and deceleration times and S-curves. Parameter <i>o1-03 [Keypad Display Unit Selection]</i> sets the display units.
U1-18 (0061)	oPE Fault Parameter	Shows the parameter number that caused the <i>oPE02 [Parameter Range Setting Error]</i> or <i>oPE08 [Parameter Selection Error]</i> .
U1-19 (0066)	Serial Error Code	Shows the contents of the serial communication error where 1 = "error" and 0 = "no error". bit0 : CRC Error bit1 : Data Length Error bit2 : Not used (normal value of 0). bit3 : Parity Error bit4 : Overrun Error bit5 : Framing Error bit6 : Timed Out bit7 : Not used (normal value of 0).
U1-24 (007D)	Input Pulse Monitor	Shows the frequency to pulse train input terminal RP.
U1-25 (004D)	SoftwareNumber Flash	Shows the FLASH ID.
U1-26 (005B)	SoftwareNumber ROM	Shows the ROM ID.
U1-50 (1199) Expert	Virtual Analog Input	Shows the virtual analog input value.
U1-60 (1089)	System Setpoint	Shows the PID Setpoint.
U1-61 (108A)	System Feedback	Shows the PID Feedback.

7 Parameter List

No. (Hex.)	Name	Description
U1-64 (108D)	Motor Speed	Shows the absolute value of the parameter <i>U1-02 [Output Frequency]</i> converted to RPM.
U1-99 (3BAE)	Anti-No-Flow Timer	Shows the value of the anti-no-flow timer. When this value is at the <i>Y2-24 [Anti-No-Flow Detection Time]</i> setting, the anti-no-flow feature starts to decrease the output frequency.

■ U2: Fault Trace

No. (Hex.)	Name	Description
U2-01 (0080)	Current Fault	Shows the fault that the drive has when viewing the monitor.
U2-02 (0081)	Previous Fault	Shows the fault that occurred most recently.
U2-03 (0082)	Freq Reference@Fault	Shows the frequency reference at the fault that occurred most recently.
U2-04 (0083)	Output Freq @ Fault	Shows the output frequency at the fault that occurred most recently.
U2-05 (0084)	Output Current@Fault	Shows the motor current at the fault that occurred most recently.
U2-07 (0086)	Output Voltage@Fault	Shows the output voltage reference at the fault that occurred most recently.
U2-08 (0087)	DC Bus Voltage@Fault	Shows the DC bus voltage at the fault that occurred most recently.
U2-09 (0088)	Output Power @ Fault	Shows the output power at the fault that occurred most recently.
U2-11 (008A)	Byp Inp Terminal Status @ Fault	Shows the status of the bypass digital input terminals at the most recent fault where 1 = (ON) and 0 = (OFF). bit 0 : Digital Input 1 (TB2-1) bit 1 : Digital Input 2 (TB2-2) bit 2 : Digital Input 3 (TB2-3) bit 3 : Digital Input 4 (TB2-4) bit 4 : Digital Input 5 (TB2-5) bit 5 : Digital Input 6 (TB2-6) bit 6 : Digital Input 7 (TB2-7) bit 7 : Digital Input 8 (TB2-8)
U2-12 (008B)	Byp Relay Status @ Fault	Shows the status of the bypass digital output terminals at the most recent fault where 1 = (ON) and 0 = (OFF). bit 0 : K1 (Input Contactor) bit 1 : K2 (Output Contactor) bit 2 : K3 (Bypass Contactor) bit 3 : K4 (Motor 1 Output Contactor) bit 4 : K5 (Motor 2 Output Contactor) bit 5 : Fan Output Relay bit 6 : Digital Output 7 (TB1 1~3) (Z2-23) bit 7 : Digital Output 8 (TB1 4~6) (Z2-24)
U2-13 (008C)	Bypass Status @ Fault	Shows the status of the bypass at the most recent fault where 1 = (ON) and 0 = (OFF). bit 0 : Hand Mode Active bit 1 : Off Mode Active bit 2 : Auto Mode Active bit 3 : Drive Mode bit 4 : Bypass Mode bit 5 : Emergency Override Bypass bit 6 : Emergency Override Drive bit 7 : Safety Open
U2-14 (008D)	Elapsed Time @ Fault	Shows the cumulative operation time of the drive at the fault that occurred most recently.
U2-15 (07E0)	SFS Output @ Fault	Shows the output frequency after soft start at the fault that occurred most recently.
U2-16 (07E1)	q-Axis Current@Fault	Shows the q-Axis current of the motor at the fault that occurred most recently.

No. (Hex.)	Name	Description
U2-20 (008E)	Heatsink Temp @Fault	Shows the heatsink temperature at the fault that occurred most recently.
U2-30 (3008)	Fault 1 YYYY	Shows the year when the most recent fault occurred.
U2-31 (3009)	Fault 1 MMDD	Shows the month and day when the most recent fault occurred.
U2-32 (300A)	Fault 1 HHMM	Shows the time when the most recent fault occurred.

■ U3: Fault History

No. (Hex.)	Name	Description
U3-01 (0090)	1st MostRecent Fault	Shows the fault history of the most recent fault.
U3-02 (0091)	2nd MostRecent Fault	Shows the fault history of the second most recent fault.
U3-03 (0092)	3rd MostRecent Fault	Shows the fault history of the third most recent fault.
U3-04 (0093)	4th MostRecent Fault	Shows the fault history of the fourth most recent fault.
U3-05 (0804)	5th MostRecent Fault	Shows the fault history of the fifth most recent fault.
U3-06 (0805)	6th MostRecent Fault	Shows the fault history of the sixth most recent fault.
U3-07 (0806)	7th MostRecent Fault	Shows the fault history of the seventh most recent fault.
U3-08 (0807)	8th MostRecent Fault	Shows the fault history of the eighth most recent fault.
U3-09 (0808)	9th MostRecent Fault	Shows the fault history of the ninth most recent fault.
U3-10 (0809)	10th MostRecentFault	Shows the fault history of the tenth most recent fault.
U3-11 (0094)	ElapsedTime@1stFault	Shows the cumulative operation time when the most recent fault occurred.
U3-12 (0095)	ElapsedTime@2ndFault	Shows the cumulative operation time when the second most recent fault occurred.
U3-13 (0096)	ElapsedTime@3rdFault	Shows the cumulative operation time when the third most recent fault occurred.
U3-14 (0097)	ElapsedTime@4thFault	Shows the cumulative operation time when the fourth most recent fault occurred.
U3-15 (080E)	ElapsedTime@5thFault	Shows the cumulative operation time when the fifth most recent fault occurred.
U3-16 (080F)	ElapsedTime@6thFault	Shows the cumulative operation time when the sixth most recent fault occurred.
U3-17 (0810)	ElapsedTime@7thFault	Shows the cumulative operation time when the seventh most recent fault occurred.
U3-18 (0811)	ElapsedTime@8thFault	Shows the cumulative operation time when the eighth most recent fault occurred.
U3-19 (0812)	ElapsedTime@9thFault	Shows the cumulative operation time when the ninth most recent fault occurred.
U3-20 (0813)	ElapsedTime@10 Fault	Shows the cumulative operation time when the tenth most recent fault occurred.

7 Parameter List

No. (Hex.)	Name	Description
U3-21 (300B)	Fault 1 YYYY	Shows the year when the most recent fault occurred.
U3-22 (300C)	Fault 1 MMDD	Shows the month and day when the most recent fault occurred.
U3-23 (300D)	Fault 1 HHMM	Shows the time when the most recent fault occurred.
U3-24 (300E)	Fault 2 YYYY	Shows the year when the second most recent fault occurred.
U3-25 (300F)	Fault 2 MMDD	Shows the month and day when the second most recent fault occurred.
U3-26 (3010)	Fault 2 HHMM	Shows the time when the second most recent fault occurred.
U3-27 (3011)	Fault 3 YYYY	Shows the year when the third most recent fault occurred.
U3-28 (3012)	Fault 3 MMDD	Shows the month and day when the third most recent fault occurred.
U3-29 (3013)	Fault 3 HHMM	Shows the time when the third most recent fault occurred.
U3-30 (3014)	Fault 4 YYYY	Shows the year when the fourth most recent fault occurred.
U3-31 (3015)	Fault 4 MMDD	Shows the month and day when the fourth most recent fault occurred.
U3-32 (3016)	Fault 4 HHMM	Shows the time when the fourth most recent fault occurred.
U3-33 (3017)	Fault 5 YYYY	Shows the year when the fifth most recent fault occurred.
U3-34 (3018)	Fault 5 MMDD	Shows the month and day when the fifth most recent fault occurred.
U3-35 (3019)	Fault 5 HHMM	Shows the time when the fifth most recent fault occurred.
U3-36 (301A)	Fault 6 YYYY	Shows the year when the sixth most recent fault occurred.
U3-37 (301B)	Fault 6 MMDD	Shows the month and day when the sixth most recent fault occurred.
U3-38 (301C)	Fault 6 HHMM	Shows the time when the sixth most recent fault occurred.
U3-39 (301D)	Fault 7 YYYY	Shows the year when the seventh most recent fault occurred.
U3-40 (301E)	Fault 7 MMDD	Shows the month and day when the seventh most recent fault occurred.
U3-41 (301F)	Fault 7 HHMM	Shows the time when the seventh most recent fault occurred.
U3-42 (3020)	Fault 8 YYYY	Shows the year when the eighth most recent fault occurred.
U3-43 (3021)	Fault 8 MMDD	Shows the month and day when the eighth most recent fault occurred.
U3-44 (3022)	Fault 8 HHMM	Shows the time when the eighth most recent fault occurred.
U3-45 (3023)	Fault 9 YYYY	Shows the year when the ninth most recent fault occurred.
U3-46 (3024)	Fault 9 MMDD	Shows the month and day when the ninth most recent fault occurred.
U3-47 (3025)	Fault 9 HHMM	Shows the time when the ninth most recent fault occurred.

No. (Hex.)	Name	Description
U3-48 (3026)	Fault 10 YYYY	Shows the year when the tenth most recent fault occurred.
U3-49 (3027)	Fault 10 MMDD	Shows the month and day when the tenth most recent fault occurred.
U3-50 (3028)	Fault 10 HHMM	Shows the time when the tenth most recent fault occurred.

■ U4: Maintenance Monitors

No. (Hex.)	Name	Description
U4-01 (004C)	Cumulative Ope Time	Shows the cumulative operation time of the drive.
U4-02 (0075)	Num of Run Commands	Shows how many times that the drive has received a Run command.
U4-03 (0067)	Cooling Fan Ope Time	Shows the cumulative operation time of the cooling fans.
U4-04 (007E)	Cool Fan Maintenance	Shows the cumulative operation time of the cooling fans as a percentage of the replacement life of the cooling fans.
U4-05 (007C)	CapacitorMaintenance	Shows the operation time of the electrolytic capacitors for the main circuit and control circuit as a percentage of the replacement life of the electrolytic capacitors.
U4-06 (07D6)	PreChargeRelayMainte	Shows the operation time of the soft charge bypass relay as a percentage of the replacement life of the soft charge bypass relay.
U4-07 (07D7)	IGBT Maintenance	Shows the operation time of the IGBTs as a percentage of the replacement life of the IGBTs.
U4-08 (0068)	Heatsink Temperature	Shows the heatsink temperature of the drive.
U4-09 (005E)	LED Check	Turns on the LED Status Ring and all of the keypad LEDs to make sure that the LEDs operate correctly.
U4-10 (005C)	kWh, Lower 4 Digits	Shows the lower 4 digits of the watt hour value for the drive.
U4-11 (005D)	kWh, Upper 5 Digits	Shows the upper 5 digits of the watt hour value for the drive.
U4-13 (07CF)	Peak Hold Current	Shows the hold value of the peak value (rms) for the drive output current.
U4-14 (07D0)	PeakHold Output Freq	Shows the output frequency at which the peak value (rms) of the drive output current is held.
U4-16 (07D8)	Motor oL1 Level	Shows the integrated value of <i>oL1</i> [<i>Motor Overload</i>] as a percentage of <i>oL1</i> detection level.
U4-18 (07DA)	Reference Source	Shows the selected frequency reference source.
U4-19 (07DB)	Modbus FreqRef (dec)	Shows the frequency reference sent to the drive from the MEMOBUS/Modbus communications as a decimal.
U4-20 (07DC)	Option Freq Ref (dec)	Shows the frequency reference sent to the drive from the communication option as a decimal.
U4-21 (07DD)	Run Command Source	Shows the selected Run command source.

7 Parameter List

No. (Hex.)	Name	Description
U4-22 (07DE)	Modbus CmdData (hex)	Shows the operation signal (register 0001H) sent to the drive from MEMOBUS/Modbus communications as a 4-digit hexadecimal number (zero suppress). The keypad shows the operation signal as specified by these rules: bit 0 : Forward run/Stop bit 1 : Reverse run/Stop bit 2 : External fault bit 3 : Fault Reset bit 4 : Multi-function input 1 bit 5 : Multi-function input 2 bit 6 : Multi-function input 3 bit 7 : Multi-function input 4 bit 8 : Multi-function input 5 bit 9 : Multi-function input 6 bit A : Multi-function input 7 bit B : Not used (normal value of 0). bit C : Not used (normal value of 0). bit D : Not used (normal value of 0). bit E : Not used (normal value of 0). bit F : Not used (normal value of 0).
U4-23 (07DF)	Option CmdData (hex)	Shows the operation signal (register 0001H) sent to the drive from MEMOBUS/Modbus communications as a 4-digit hexadecimal number. The keypad shows the operation signal as specified by these rules: bit 0 : Forward run/Stop bit 1 : Reverse run/Stop bit 2 : External fault bit 3 : Fault Reset bit 4 : Multi-function input 1 bit 5 : Multi-function input 2 bit 6 : Multi-function input 3 bit 7 : Multi-function input 4 bit 8 : Multi-function input 5 bit 9 : Multi-function input 6 bit A : Multi-function input 7 bit B : Not used (normal value of 0). bit C : Not used (normal value of 0). bit D : Not used (normal value of 0). bit E : Not used (normal value of 0). bit F : Not used (normal value of 0).
U4-24 (07E6)	Number of Runs (Low)	Shows the lower 4 digits of the drive run count.
U4-25 (07E7)	Number of Runs(High)	Shows the lower 4 digits of the drive run count.
U4-61 (3096) Expert	Total EMOVR Run Time	Shows the length of time that the drive operated in Emergency Override Mode.
U4-75 (1BC4)	Comm Option Type	Displays the Hex address of the communication option currently connected to the drive.
U4-76 (1BC5)	MAC Address1 1, 2	Displays the first and second octets of MAC address 1.
U4-77 (1BC6)	MAC Address1 3, 4	Displays the third and fourth octets of MAC address 1.
U4-78 (1BC7)	MAC Address1 5, 6	Displays the fifth and sixth octets of MAC address 1.
U4-79 (1BC8) Expert	MAC Address2 1, 2	Displays the first and second octets of MAC address 2.
U4-80 (1BC9) Expert	MAC Address2 3, 4	Displays the third and fourth octets of MAC address 2.
U4-81 (1BCA) Expert	MAC Address2 5, 6	Displays the fifth and sixth octets of MAC address 2.

No. (Hex.)	Name	Description
U4-82 (1BCB) Expert	MAC Address3 1, 2	Displays the first and second octets of MAC address 3.
U4-83 (1BCC) Expert	MAC Address3 3, 4	Displays the third and fourth octets of MAC address 3.
U4-84 (1BCD) Expert	MAC Address3 5, 6	Displays the fifth and sixth octets of MAC address 3.

■ U5: PID Monitors

No. (Hex.)	Name	Description
U5-01 (0057)	PID Feedback	Shows the PID control feedback value.
U5-02 (0063)	PID Input	Shows the change between the PID setpoint and PID feedback (the quantity of PID input) as a percentage of the maximum output frequency.
U5-03 (0064)	PID Output	Shows the PID control output as a percentage of the maximum output frequency.
U5-04 (0065)	PID Setpoint	Shows the PID setpoint.
U5-05 (07D2)	PID DifferentialFdbk	Shows the PID differential feedback value as a percentage of the maximum output frequency.
U5-06 (07D3)	PID FdbkDif PID Fdbk	Shows the difference from calculating " <i>U5-05 [PID DifferentialFdbk] - U5-01 [PID Feedback]</i> ".
U5-07 (0072)	AUTO Mode Freq Ref	Shows the Frequency reference value at AUTO Mode.
U5-08 (0073)	HAND Mode Freq Ref	Shows the Frequency reference value at HAND Mode.
U5-14 (086B)	PID Out2 Upr4 Digits	Shows the custom PI output.
U5-15 (086C)	PID Out2 Lwr4 Digits	Shows the custom PI output.
U5-16 (086D)	PI Aux Ctrl Feedback	Shows the PI Auxiliary Control Feedback level from the terminal set for <i>H3-xx = 27 [PI Auxiliary Control Feedback]</i> .
U5-17 (086E)	PI2 Control Setpoint	Shows the PI2 Control setpoint.
U5-18 (086F)	PI2 Control Feedback	Shows the PI2 Control Feedback Level from the terminal set for <i>H3-xx = 26 [PI2 Control Feedback]</i> .
U5-19 (0870)	PI2 Control Input	Shows the PI2 Control input (deviation between PI target and feedback).
U5-20 (0871)	PI2 Control Output	Shows the PI2 Control output.
U5-30 (3000)	Time Hr Min HHMM	Shows the current time (Hours and Minutes).
U5-31 (3001)	Date Year	Shows the current year.
U5-32 (3002)	Date Mo Day MMDD	Shows the current date (Month and Date).

7 Parameter List

No. (Hex.)	Name	Description
U5-33 (3003)	Date Week	Shows the current date of the week. bit 0 : Sunday bit 1 : Monday bit 2 : Tuesday bit 3 : Wednesday bit 4 : Thursday bit 5 : Friday bit 6 : Saturday bit 7 : Not used (normal value of 0).
U5-79 (3B9A)	PID Feedback Backup	Shows the <i>PID Feedback Backup</i> [H3-xx = 24] signal that the drive uses when it loses the <i>PID Feedback</i> [H3-xx = B].
U5-81 (3B9C)	Diff Level Source	Shows the Differential Feedback signal from the terminal set for H3-xx = 2D [<i>Differential Level Source</i>].
U5-99 (1599)	Setpoint	Shows the PID setpoint command.

■ U6: Operation Status Monitors

No. (Hex.)	Name	Description
U6-01 (0051)	Iq Secondary Current	Shows the value calculated for the motor secondary current (q-Axis) as a percentage of the motor rated secondary current.
U6-17 (07D1) Expert	Energy Save Coeff	Shows the total time of direction of motor rotation detections for Speed Estimation Speed Searches. This value adjusts b3-26 [<i>Direction Determination Level</i>].
U6-21 (07D5)	Offset Frequency	Shows the total value of d7-01 to d7-03 [<i>Offset Frequency 1 to 3</i>] selected with <i>Add Offset Frequency 1 to 3</i> [H1-xx = 44 to 46].
U6-31 (007B)	TorqueDetect Monitor	Monitors the torque reference or the output current after applying the filter.
U6-36 (0720) Expert	Comm Errors-Host	Shows the number of inter-CPU communication errors. When you de-energize the drive, this value resets to 0.
U6-37 (0721) Expert	Comm Errors-Sensor	Shows the number of inter-CPU communication errors. When you de-energize the drive, this value resets to 0.
U6-80 (07B0)	Option IP Address 1	Shows the currently available local IP Address (1st octet).
U6-81 (07B1)	Option IP Address 2	Shows the currently available local IP Address (2nd octet).
U6-82 (07B2)	Option IP Address 3	Shows the currently available local IP Address (3rd octet).
U6-83 (07B3)	Option IP Address 4	Shows the currently available local IP Address (4th octet).
U6-84 (07B4)	Online Subnet 1	Shows the currently available subnet mask (1st octet).
U6-85 (07B5)	Online Subnet 2	Shows the currently available subnet mask (2nd octet).
U6-86 (07B6)	Online Subnet 3	Shows the currently available subnet mask (3rd octet).
U6-87 (07B7)	Online Subnet 4	Shows the currently available subnet mask (4th octet).
U6-88 (07B8)	Online Gateway 1	Shows the currently available Gateway address (1st octet).
U6-89 (07B9)	Online Gateway 2	Shows the currently available Gateway address (2nd octet).

No. (Hex.)	Name	Description
U6-90 (07F0)	Online Gateway 3	Shows the currently available Gateway address (3rd octet).
U6-91 (07F1)	Online Gateway 4	Shows the currently available Gateway address (4th octet).
U6-92 (07F2)	Online Speed	Shows the currently available communications speed.
U6-93 (07F3)	Online Duplex	Shows the currently available Duplex setting.
U6-98 (07F8)	First Fault	Shows the contents of the most recent communication options fault (Modbus TCP/IP, EtherNet/IP).
U6-99 (07F9)	Current Fault	Shows the contents of current fault from communication options (Modbus TCP/IP, EtherNet/IP).

■ Ub: Bypass Control Monitors

No. (Hex.)	Name	Description
Ub-01 (8780)	Motor Current	Format is XXX.X amps. The number of decimal places depends on drive kVA rating.
Ub-02 (8781)	Bypass Digital Input Status	View status of bypass digital inputs XXXXXXXX bit 0 : Digital Input 1 (TB2-1) bit 1 : Digital Input 2 (TB2-2) bit 2 : Digital Input 3 (TB2-3) bit 3 : Digital Input 4 (TB2-4) bit 4 : Digital Input 5 (TB2-5) bit 5 : Digital Input 6 (TB2-6) bit 6 : Digital Input 7 (TB2-7) bit 7 : Digital Input 8 (TB2-8)
Ub-03 (8782)	Bypass Digital Output Status	View status of bypass digital outputs XXXXXXXX bit 0 : K1 (Input Contactor) bit 1 : K2 (Output Contactor) bit 2 : K3 (Bypass Contactor) bit 3 : K4 (Motor 1 Output Contactor) bit 4 : K5 (Motor 2 Output Contactor) bit 5 : Fan Output Relay bit 6 : Digital Output 7 (TB1 1~3) (Z2-23) bit 7 : Digital Output 8 (TB1 4~6) (Z2-24) bit 8 : Digital Output 9 (TB1 7~9) (Z2-25) bit 9 : Digital Output 10 (TB1 10~12) (Z2-26) bit 10 and 11 : Reserved
Ub-04 (8783)	Bypass Dig Out Status D09/D10	View status of bypass digital outputs XXXXXXXX bit 0 : Digital Output 9 (TB1 7~9) (Z2-25) bit 1 : Digital Output 10 (TB1 10 ~ 12) (Z2-26)

7 Parameter List

No. (Hex.)	Name	Description
Ub-05 (8784)	Bypass Status 1	bit 0 : HAND Mode : 0: Not in HAND : 1: In HAND Mode bit 1 : OFF Mode : 0: Not in OFF : 1: In OFF Mode bit 2 : AUTO Mode : 0: Not in AUTO : 1: In AUTO Mode bit 3 : DRIVE mode (cmd) : 0: Drive mode not commanded : 1: Drive mode commanded bit 4 : BYPASS mode (cmd) : 0: Bypass mode not commanded : 1: Bypass mode commanded bit 5 : Emergency override BYP Act : 0: Not active : 1: Emergency override bypass is active bit 6 : Emergency override DRV Act : 0: Not active : 1: EMOV Drive is active (Emergency override drive) bit 7 : Safety Open : 0: All programmed safeties closed : 1: At least one programmed safety open bit 8 : Alarm Active : 0: No Alarm : 1: Alarm bit 9 : Drive Run active : 0: Not running in drive : 1: Running in drive mode bit 10 : Bypass run active : 0: Not running in bypass : 1: Running in bypass mode bit 11 : Emergency override Drive REV : 0: running FWD : 1: running REV bit 12 : Drive comms active : 0: Drive comms Not active : 1: Drive comms active bit 13 : System READY : 0: Not READY : 1: READY

No. (Hex.)	Name	Description
Ub-06 (8785)	Bypass Status 2	bit 0 : Interlock Open : 0: Interlock is pen : 1: Interlock is closed bit 1 : RUN active : 0: No RUN active : 1: Bypass or Drive run active bit 2 : Fault active : 0: Fault not active : 1: Fault active bit 3 : Auto Xfer Active : 0: Auto Xfer not Active : 1: Auto Xfer Active bit 4 : Remote Xfer Active : 0: Remote Xfer not Active : 1: Remote Xfer Active bit 5 : Energy Sav Active : 0: Energy Savings not Active : 1: Energy Savings Active bit 6 : Motor 1 Selected : 0: Motor 1 not Selected : 1: Motor 1 Selected bit 7 : Motor 2 Selected : 0: Motor 2 not selected : 1: Motor 2 selected bit 8 : Run verify detected : 0: Run verify not detected : 1: Run verify detected bit 9 : Restart delay active : 0: Restart delay not active : 1: Restart delay active bit 10 to 15 : Reserved
Ub-07 (8786)	Bypass Fault Status 1	bit 0 : Drive Fault bit 1 : Safety Open bit 2 : FB02-Wait For Interlock Timeout bit 3 : FB03-External Fault Bypass (EFB) bit 4 : FB13-Loss Of Load bit 5 : FB05-Motor Overload (Internal, Electronic) bit 6 : FB06-External Overload 1 bit 7 : FB07-External Overload 2 bit 8 to 11 : Reserved
Ub-08 (8787)	Bypass Fault Status 2	bit 0 : FB08-Brownout Detected bit 1 : FB09-Blackout Detected bit 2 : FB10-Loss of Drive Communications bit 3 : FB15-Input Phase Loss bit 4 : FB26-Option on Drive Detected bit 5 : FB13-Loss of Load bit 6 : CE-Serial Communications Error bit 7 : FB16-Input Phase Rotation bit 8 : FB18-Welded Bypass Contactor Detected bit 9 to 11 : Reserved
Ub-09 (8788)	Current Fault	Displays the current fault.
Ub-10 (8789)	Current Fault YYYY	Displays the year of the current fault.
Ub-11 (878A)	Current Fault MMDD	Displays the month and day of the current fault.
Ub-12 (878B)	Current Fault HHMM	Displays the hour and minute of the current fault.
Ub-13 (878C)	Previous Fault	Displays the previous fault.
Ub-14 (878D)	Previous Fault YYYY	Displays the year of the previous fault.

7 Parameter List

No. (Hex.)	Name	Description
Ub-15 (878E)	Previous Fault MMDD	Displays the month and day of the previous fault.
Ub-16 (878F)	Previous Fault HHMM	Displays the hour and minute of the previous fault.
Ub-17 (8790)	Contactors Voltage	Displays the measured voltage for the power going to the contactor coils.
Ub-18 (8791)	Software Version	Displays the software version currently programmed into the bypass.
Ub-19 (8792)	Date Year YYYY	Displays the current year.
Ub-20 (8793)	Date Month Day MMDD	Displays the current date (Month and Date).
Ub-21 (8794)	Time Hour Min HHMM	Displays the current time (Hours and Minutes).
Ub-22 (8795)	Bypass Analog Input	Bypass MFAI level
Ub-23 (8796)	Motor 1 Overload	Motor 1 Overload level
Ub-24 (8797)	Motor 2 Overload	Motor 2 Overload level
Ub-94 (87DD)	Bypass CPU Usage	Current Bypass CPU Load
Ub-95 (87DE)	Line Frequency	Calculated AC line frequency
Ub-96 (87DF)	By Phase Loss Level	Current Phase Loss level
Ub-99 (87E2) Expert	Desired FP605 software version	Shows the latest version of FP605 software that this version of FP605 Bypass software supports.

■ UC: BACnet Diagnostic Monitors

No. (Hex.)	Name	Description
UC-01 (3DB0)	BN MSTP Net Health	Shows a number between 0.0% and 100.0% that identifies the health of the MSTP network. This number is dependent on the number of CRC errors, token losses, token retries, and net downtime perceived.
UC-02 (3DB1)	BACnet Tokens Rx	Shows the number of received MSTP Tokens after you energize the drive.
UC-03 (3DB2)	BACnet Tokens Tx	Shows the number of transmitted MSTP Tokens after you energize the drive.
UC-04 (3DB3)	BACnet Messages Rx	Shows the number of messages with data (non-token, non-polling) received by the drive.
UC-05 (3DB4)	BACnet Messages Tx	Shows the number of messages with data (non-token, non-polling) transmitted by the drive.
UC-06 (3DB5)	MSTP Next Node Addr	Shows the next known node in the MSTP loop. This is the node to which the drive will pass the token.
UC-07 (3DB6)	MSTP Prev Node Addr	Shows the previous known node in the MSTP loop. This is the node from which the drive received the token.
UC-08 (3DB7)	MSTP H MAC Found	Shows the highest MAC address found on the network. This will report the highest value MAC address to which the token was passed by any node on the MSTP loop.
UC-09 (3DB8)	MSTP L MAC Found	Shows the lowest MAC address found on the network. This will report the lowest value MAC address to which the token was passed by any node on the MSTP loop.
UC-10 (3DB9)	MSTP # Nodes Found	Shows the number of unique nodes that transmitted a token on the local MSTP loop.

No. (Hex.)	Name	Description
UC-11 (3DBA)	# of BN COV Sbscript	Shows the number of COV subscriptions requested by the nodes on the BACnet network. This is limited to the number of objects that support COV subscriptions.
UC-12 (3DBB)	MSTP Loop Time	Shows the number of milliseconds between drive transmitted token and drive token received, showing how long the MSTP loop took to pass the token to all nodes on the MSTP network.
UC-13 (3DBC) Expert	BN MSTP CRC Errors	Shows the number of CRC errors detected after you energize the drive.
UC-14 (3DBD) Expert	BN MSTP Tokens Lost	Shows the number of token losses seen by the unit since power-on. This is sensed by a net deadtime of more than 500 ms.
UC-15 (3DBE) Expert	BN MSTP Tokens Retry	Shows the number of token retries seen by the unit since power-on. This is sensed by two subsequent token frames seen from the same node to the same node with the same CRC.
UC-16 (3DBF) Expert	BN MSTP Silence Avg	Shows the average net deadtime (space between active messages), averaged over a 60 packet period.

8 Network Communications

◆ Section Safety

⚠ DANGER Do not ignore the safety messages in this manual. If you ignore the safety messages in this manual, it will cause serious injury or death. The manufacturer is not responsible for injuries or damage to equipment.

◆ Fieldbus Network Support

You can use a PLC or building automation controller to control and monitor the bypass through the network. The bypass has a standard RS-485 interface (serial communications). Install a separately sold communication option on the bypass to support other network communications.

■ Available Communication Options

Refer to [Table 8.1](#) for the fieldbus networks that are compatible with the bypass. Contact Yaskawa or your nearest sales representative to order a communication option.

Table 8.1 Available Fieldbus Network

Type of Communications	Option Models	Type of Communications	Option Models
LonWorks	SI-W3	Dual port Modbus TCP/IP	SI-EM3D
Modbus TCP/IP	SI-EM3	Dual port EtherNet/IP	SI-EN3D
PROFINET	SI-EP3	BACnet/IP	JOHB-SMP3
EtherNet/IP	SI-EN3		

◆ BACnet Communications

This section gives detailed information about the parameters, error codes, and communication procedures for BACnet communications.

■ Configure Master/Slave

You can monitor and control the bypasses from a controller on a Building Automation and Control network (BACnet) with RS-485 technology and Master-Slave/Token-Passing (MS-TP) protocol. The drives agree with the device profile of the BACnet Application Specific Controller (B-ASC).

A maximum of 127 bypasses can communicate on a single BACnet MS-TP network depending on network conditions. When more bypasses or BACnet devices are necessary, a BACnet router is necessary to let another MS-TP network be available with a possible maximum of another 127 bypasses.

You can use parameters to set the MSTP MAC address, MSTP baud rate, and Device Object ID. You can also use parameters to set Device object properties Max Masters and Max Info Frames. Set other Device Object properties, for example Device Object Name and Device Object Location, through the BACnet network after you connect the bypass and the bypass is communicating.

When you set the addressing, a controller can start communication to the bypass. The bypass will do the specified function and send a response back to the controller. The bypass will usually respond immediately, but can delay its response until it gets the token for commands that can take longer local processing time.

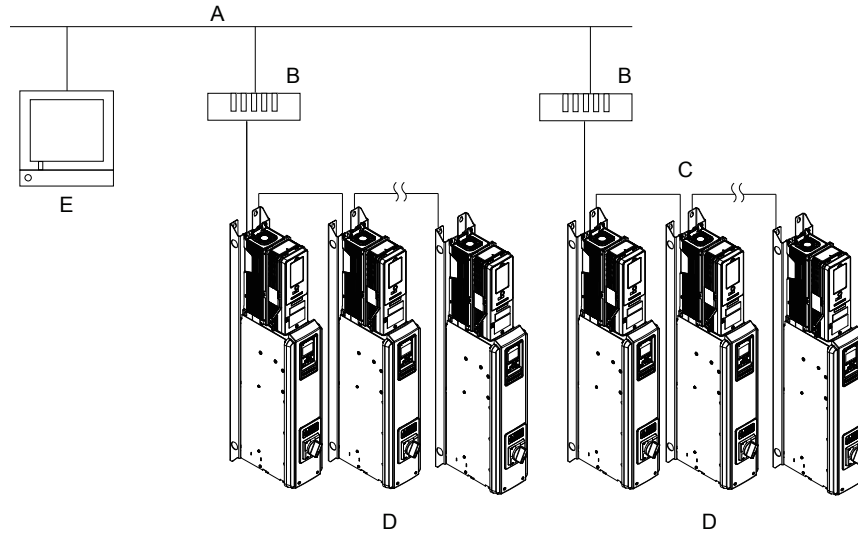

A - BACnet over Ethernet
 B - Router
 C - MS-TP (RS-485)

D - Bypasses
 E - BACnet Workstation

Figure 8.1 Connection Example of Multiple Bypasses to a BACnet Workstation

■ Communication Specifications

Table 8.2 lists the specifications for the BACnet communications.

Table 8.2 BACnet Specifications

Item	Specifications
Interface	Master-Slave/Token-Passing (MS-TP)
	RS-485
Communication parameter	Communications speed: 9.6, 19.2, 38.4, 76.8 kbps
	Data length: 8 bit (fixed)
	Parity: even, odd, none
	Stop Bit: 1 bit (fixed)
Communication protocol	BACnet MS-TP
Number of possible units to connect	Maximum: 127 units for each MS-TP network segment depending on network conditions.

■ Communication with the Controller

This section gives information about the settings for the termination resistor and how to connect to BACnet communications.

Connect Communications Cable

Use this procedure to start communication between the controller and bypass.

1. De-energize the bypass then connect the communications cable to the controller and the bypass. The bypass uses terminal TB3 for serial communications.

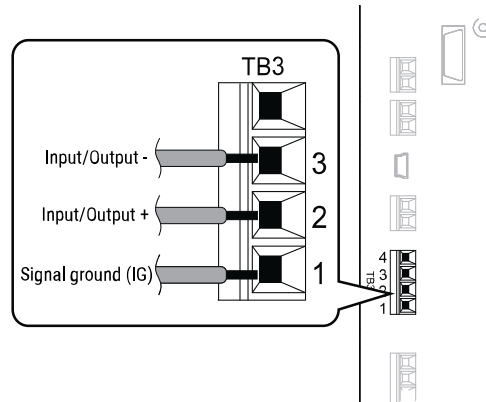

Figure 8.2 Communications Cable Connection Terminal (TB3)

Note:

Isolate the communications wiring from the main circuit wiring and other high-power wiring. Use shielded wires for the communications wiring and connect cable sheaths as shown in "Wiring Diagram for More than One Bypass". Incorrect wiring procedures could cause bypass malfunction because of electrical interference.

2. Enable the termination resistor ONLY when the bypass is at the end of the communications network. Set DIP switch S1 to the "ON" position to enable the termination resistor. Refer to "Set the Termination Resistor" for more information.
3. Energize the bypass.
4. Use the keypad to set the necessary communications parameters *H5-01 to H5-11*.
 - *H5-01 [Drive Node Address]*
 - *H5-02 [Communication Speed Selection]*
 - *H5-04 [Stopping Method after Com Error]*
 - *H5-05 [Comm Fault Detection Select]*
 - *H5-08 [Communication Protocol Selection]*
 - *H5-09 [CE Detection Time]*
5. Because communications parameters do not take effect immediately, either de-energize and re-energize the bypass or set *H5-20 = 1 [Communication Parameters Reload = Reload Now]*.

The bypass is prepared to start communication with the controller.

Set the Termination Resistor

You must enable the termination resistor on the serial terminals of the devices on the two physical ends of the network to use serial communications. Use DIP switch S1 on the bypass control PCB to enable and disable the built-in termination resistor. Refer to [Figure 8.3](#) for an example of how to set DIP switch S1. Use the tip of a tweezers or a small flat-blade screwdriver to set the DIP switch. When you install the bypass at the end of the network line, set DIP switch S1 to "ON" to enable the termination resistor. Set DIP switch S1 to "OFF" on all other bypasses.

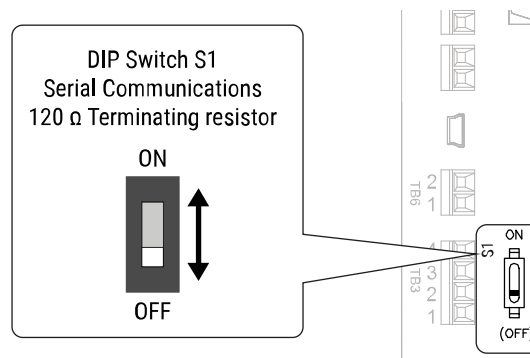

Figure 8.3 Termination Resistor DIP Switch S1

Wiring Diagram for More than One Bypass

Figure 8.4 shows how to wire more than one connected bypass using serial communications.

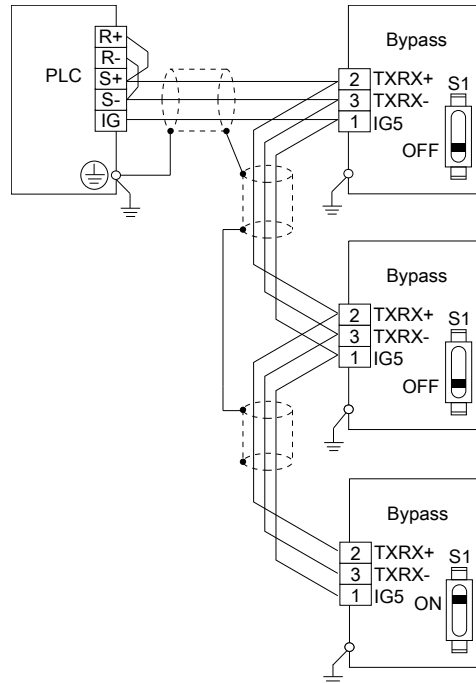

Figure 8.4 Wiring Diagram for More than One Bypass

Note:

When you install the bypass at the end of the network line, set DIP switch S1 to "ON" to enable the termination resistor. Set DIP switch S1 to "OFF" on all other bypasses.

■ Bypass Operations by Serial Communications

Parameters will apply to the settings when the bypass is running during serial communications. This section gives information about the available functions and their related parameters.

Executable Functions

A controller can do these operations with serial communications. Parameter settings (except *H5-xx*) do not have an effect on the availability of these operations.

- Monitor the bypass status and operate the bypass
- Set and view parameters
- Fault Reset Procedure

Bypass Control

To use external commands to set the frequency references and motor run/stop with serial communications, set these parameters as specified by the application:

- *b1-01* = 2 [*Frequency Reference Selection 1 = Serial Communications*]
- *b1-02* = 2 or 8 [*Run Command Selection 1 = Serial Communications or AUTO Command + Serial Run*]

For more information about operation mode selection, refer to *b1-01* and *b1-02*.

■ BACnet Objects Supported

Present Value Access

The Present Value (PV) of BACnet objects can always be read. Some PVs can also be written or commanded. A commandable PV is similar to a writable PV, but the value is actually written into a priority array. The value that then has the highest priority in the array will be used by the drive.

Table 8.3 Present Value Access Types and Descriptions

PV Access	Name	Description
C	Commandable	Value written to a priority array. The highest priority value in the array is then written to the drive.
R	Readable	Value is read-only
W	Writable	Value written to the drive

Supported Properties of Objects

Table 8.4 Object Properties

Property	Object Type						
	Device	Analog Input (AI)	Analog Output (AO)	Analog Value (AV)	Binary Input (BI)	Binary Output (BO)	Binary Value (BV)
Object_Identifier	Yes	Yes	Yes	Yes	Yes	Yes	Yes
Object_Name	Yes	Yes	Yes	Yes	Yes	Yes	Yes
Location	Yes	-	-	-	-	-	-
Object_Type	Yes	Yes	Yes	Yes	Yes	Yes	Yes
System_Status	Yes	-	-	-	-	-	-
Vendor_Name	Yes	-	-	-	-	-	-
Vendor_Identifier	Yes	-	-	-	-	-	-
Model_Name	Yes	-	-	-	-	-	-
Firmware_Revision	Yes	-	-	-	-	-	-
Protocol_Version	Yes	-	-	-	-	-	-
Protocol_Revision	Yes	-	-	-	-	-	-
Protocol_Services_Supported	Yes	-	-	-	-	-	-
Protocol_Object_Types_Supported	Yes	-	-	-	-	-	-
Object_List	Yes	-	-	-	-	-	-
Max_ADPU_Length_Accepted	Yes	-	-	-	-	-	-
Segmentation_Supported	Yes	-	-	-	-	-	-
Local_Time	Yes	-	-	-	-	-	-
Local_Date	Yes	-	-	-	-	-	-
ADPU_Timeout	Yes	-	-	-	-	-	-
Number_Of_ADPU_Retries	Yes	-	-	-	-	-	-
Max_Masters	Yes	-	-	-	-	-	-
Max_Info_Frames	Yes	-	-	-	-	-	-
Device_Address_Binding	Yes	-	-	-	-	-	-
Database_Revision	Yes	-	-	-	-	-	-
Active_COV_Subscriptions	Yes	-	-	-	-	-	-
Present_Value	-	Yes	Yes	Yes	Yes	Yes	Yes
Status_Flags	-	Yes	Yes	Yes	Yes	Yes	Yes
Event_State	-	-	-	-	-	-	-
Reliability	-	Yes	Yes	Yes	Yes	Yes	Yes
Out_Of_Service	-	Yes	Yes	Yes	Yes	Yes	Yes
Units	-	Yes	Yes	Yes	-	-	-
Priority_Array	-	-	Yes */	Yes */	-	Yes	Yes
Relinquish_Default	-	-	Yes */	Yes */	-	Yes	Yes
Polarity	-	-	-	-	Yes	Yes	-

8 Network Communications

Property	Object Type						
	Device	Analog Input (AI)	Analog Output (AO)	Analog Value (AV)	Binary Input (BI)	Binary Output (BO)	Binary Value (BV)
Inactive_Text	-	-	-	-	Yes	Yes	Yes
Active_Text	-	-	-	-	Yes	Yes	Yes
COV_Increment *2	-	Yes	Yes	Yes	-	-	-
Property_List	Yes	Yes	Yes	Yes	Yes	Yes	Yes
Local Time	Yes	-	-	-	-	-	-
Local Date	Yes	-	-	-	-	-	-

*1 For Commandable Object Instances only.

*2 COV function is only available on objects that are not commandable and not writable.

Analog Input Objects

Object ID	Object Name (Network Display, if Different)	Modbus Reg.	Precision	Range	Units	PV Access
AI1	Drive Analog Input 1 Level (Drv Anlg In 1 Level)	004Eh	XXX.X	0-100.0	%	R
AI2	Drive Analog Input 2 Level (Drv Anlg In 2 Level)	004Fh	XXX.X	0-100.0	%	R
AI3	Not Used AI3	0050h	XXX.X	0-100.0	%	R
AI4	Bypass Analog Input 1 Level (Byp Anlg In 1 Level)	8795h	XXX.X	0-100.0	%	R
AI5	Not Used AI5	-	-	-	-	R
AI6	Display Format o1-03	0502h	XXXXX	0-65535	-	R
AI7	Scale Format b5-20	01E2h	XXXXX	0-65535	-	R
AI8	Inverter Model o2-04	0508h	XXXXX	0-65535	-	R
AI9	Rated Current n9-01	05D0h	XXXX.X (for drives rated higher than 11 kVA) XXX.XX (for drives rated 11 kVA or lower)	0-6553.5 (for drives rated higher than 11 kVA) 0-65535 (for drives rated 11 kVA or lower)	A	R
AI10	Motor Current UB-01	8780h	XXXX.X (for drives rated higher than 11 kVA) XXX.XX (for drives rated 11 kVA or lower)	0-6553.5 (for drives rated higher than 11 kVA) 0-65535 (for drives rated 11 kVA or lower)	A	R
AI11	Contacting Voltage	8790h	XXXXX	0-65535	V	R

Analog Output Objects

Object ID	Object Name (Network Display)	Modbus Reg.	Precision	Range	Units	PV Access
AO1	Drive Terminal FM Analog Output Level Command (set H4-01 = 0) (Drv Anlg Out1 Level)	0007h	XXX.X	0-100.0	%	C
AO2	Drive Terminal AM Analog Output Level Command (Set H4-04 = 0) (Drv Anlg Out2 Level)	0008h	XXX.X	0-100.0	%	C

Analog Value Objects

Object ID	Object Name (Network Display, if Different)	Modbus Reg.	Precision	Range	Units	PV Access
AV1	Drive Operation Command (Operation Cmd) Note: Do not command bypass using AV1. Use BV58 to BV71 instead.	0001h	-	0-65535	Bitmap	C
AV2	Frequency Cmd	0002h	XXX.XX Determined by o1-03	0-600.00	Determined by o1-03	C
AV3	PI Setpoint Cmd	0006h	XXX.XX	0-100.00	%	C
AV4	Drive Multi-Function Output Command (MF Output Cmd) <ul style="list-style-type: none"> • bit 0: Multi-Function Digital Output 1 (terminal M1-M2) • bit 1: Multi-Function Digital Output 2 (terminal M3-M4) • bit 2: Multi-Function Digital Output 3 (terminal MD-ME-MF) • bit 3: Reserved • bit 4: Reserved • bit 5: Reserved • bit 6: Enables the function in bit 7 • bit 7: Fault Contact Output (terminal MA-MB-MC) • bit 8 to F: Reserved Note: When using AV4, do not use BO1 to BO3 or BV12.	0009h	-	0-255	Bitmap	C
AV5	Drive Reference Select Command (Reference Select Cmd) <ul style="list-style-type: none"> • bit 0: Reserved • bit 1: PID Setpoint Input • bit 2: Reserved • bit 3: Reserved • bit 4: PI2 Target Input • bit 5 to B: Reserved • bit C: Multi-Function Input 5 • bit D: Multi-Function Input 6 • bit E: Multi-Function Input 7 • bit F: Reserved Note: When you use AV5, you must not use AV1, BO4, or BV9 to BV11.	000Fh	-	0-32767	Bitmap	C

8 Network Communications

Object ID	Object Name (<i>Network Display, if Different</i>)	Modbus Reg.	Precision	Range	Units	PV Access
AV6	System Status (<i>Drive Status</i>) <ul style="list-style-type: none"> • bit 0: During Run (drive or bypass) • bit 1: During Reverse • bit 2: System ready • bit 3: System faulted • bit 4: Data Setting Error • bit 5: Multi-Function Digital Output 1 (terminal M1-M2) • bit 6: Multi-Function Digital Output 2 (terminal M3-M4) • bit 7: Multi-Function Digital Output 3 (terminal MD-ME-MF) • bit 8 to D: Reserved • bit E: ComRef status • bit F: ComCtrl status 	0020h	-	0-65535	Bitmap	R
AV7	Fault Details <ul style="list-style-type: none"> • bit 0: oC [Overcurrent], GF [Ground Fault] • bit 1: ov [Overvoltage] • bit 2: oL2 [Drive Overload] • bit 3: oH1 [Heatsink Overheat], oH2 [External Overheat (H1-XX=B)] • bit 4 to 6: Reserved • bit 7: EF to EF7 [External Fault] • bit 8: CPFxx [Hardware Fault] (includes oFAxx) • bit 9: oL1 [Motor Overload], oL3 [Overtorque Detection 1], UL3 [Undertorque Detection 1] • bit A: Reserved • bit B: Uv [DC Bus Undervoltage] • bit C: Uv1 [DC Bus Undervoltage], Uv2 [Control Power Undervoltage], Uv3 [Soft Charge Answerback Fault] • bit D: LF [Output Phase Loss], PF [Input Phase Loss] • bit E: CE [Serial Communication Error], bUS [Option Communication Error] • bit F: oPr [Keypad Connection Fault] 	0021h	-	0-65535	Bitmap	R
AV8	Data Link Status <ul style="list-style-type: none"> • bit 0: Writing Data • bit 1: Reserved • bit 2: Reserved • bit 3: Upper or lower limit error • bit 4: Data conformity error • bit 5: Writing to EEPROM • bit 6 to F: Reserved 	0022h	-	0-63	Bitmap	R

Object ID	Object Name (Network Display, if Different)	Modbus Reg.	Precision	Range	Units	PV Access
AV9	Frequency Reference	0040h	XXX.XX Determined by o1-03	0-600.00	Determined by o1-03	R
AV10	Output Frequency	0041h	XXX.XX Determined by o1-03	0-600.00	Determined by o1-03	R
AV11	Output Voltage	0045h	XXXX.X	0-6553.5	V	R
AV12	Output Current	0026h	XXXX.X	0-6553.5	A	R
AV13	Output Power	0047h	XXXX.X > 11kVA XXX.XX <= 11kVA	0-6553.5 > 11kVA 0-655.35 <= 11kVA	KW	R
AV14	Torque Reference	0048h	XXXX.X	0-100.0	%	R
AV15	Drive Multi-Function Input Status (MF Input Status)	002Bh	XXX	0-127	Bitmap	R
AV16	Drive Status 2	002Ch	XXXXX	0-65535	Bitmap	R
AV17	Drive Multi-Function Output Status (MF Output Status)	002Dh	XXX	0-135	Bitmap	R
AV18	DC Bus Voltage	0031h	XXXX.X	0-6553.5	V	R
AV19	PI Feedback Level	0038h	XXXX.X	0-100.0	%	R
AV20	PI Input Level	0039h	XXXX.X	0-100.0	%	R
AV21	PI Output Level	003Ah	XXXX.X	0-100.0	%	R
AV22	Drive SW Num	004Dh	XXXXX	0-65535	-	R
AV23	Bypass SW Num	8791h	XXXXX	0-65535	-	R
AV24	Comm Error Detail	003Dh	XXX	0-127	Bitmap	R
AV25	KVA Setting	0508h	XXXXX	-	Enumerated Data Vendor Specific	R
AV26	Control Method	0043h	XXXXX	-	Enumerated Data Vendor Specific	R
AV27	Accel Time	0200h	XXXX.X	0-6000.0	S	W
AV28	Decel Time	0201h	XXXX.X	0-6000.0	S	W
AV29	Parameter Number	####h Determined in runtime	XXXXX	0-65535	-	W
AV30	Parameter Data	####h Determined in runtime	XXXXX	0-65535	-	W
AV31	Motor Current	8780h	XXXX.X > 11 kVA XXX.XX <= 11 kVA	0-6553.5 > 11 kVA 0-655.35 <= 11 kVA	A	R
AV32	120V to Kx Coils	8790h	XXXXX	0-65535	V	R
AV33	Drive kWh consumed (kWh consumed)	005Ch -005Dh	XXXXXXXXXX	0-999999999	kWh	R
AV34	Not Used AV34	-	-	-	-	R
AV35	Drive Run Time	004Ch	XXXXX	0-65535	Hours	R
AV36	Out Freq in %	003Fh	XXX.XX	0-100.00	%	R
AV37	Out Freq in RPM	003Eh	XXXXX	0-65535	RPM	R
AV38	Torque Iq (U6-01)	0051h	XXXX.X	0-6553.5	%	R
AV39	Drive HOA Status	004Bh	X	0-2	-	R
AV40	Last Drive Fault Refer to page 80 for information on fault decimal values.	0081h	XXXXX	0-65535	-	R

8 Network Communications

Object ID	Object Name (<i>Network Display, if Different</i>)	Modbus Reg.	Precision	Range	Units	PV Access
AV41	Last Bypass Fault Refer to page 80 for information on fault decimal values.	878Ch	XXXXXX	0-65535	-	R
AV42	Current Sys Fault (<i>Current Sys Flt</i>) Refer to 80 for information on fault decimal values.	0080h	XXXXXX	0-65535	-	R

Binary Input Objects

Object ID	Object Name (<i>Network Display, if Different</i>)	Modbus Reg.	Active Text	Inactive Text	PV Access
BI1	Drive Input Terminal 1 (<i>Input Terminal 1</i>)	002Bh:bit 0	ON	OFF	R
BI2	Drive Input Terminal 2 (<i>Input Terminal 2</i>)	002Bh:bit 1	ON	OFF	R
BI3	Drive Input Terminal 3 (<i>Input Terminal 3</i>)	002Bh:bit 2	ON	OFF	R
BI4	Drive Input Terminal 4 (<i>Input Terminal 4</i>)	002Bh:bit 3	ON	OFF	R
BI5	Drive Input Terminal 5 (<i>Input Terminal 5</i>)	002Bh:bit 4	ON	OFF	R
BI6	Drive Input Terminal 6 (<i>Input Terminal 6</i>)	002Bh:bit 5	ON	OFF	R
BI7	Drive Input Terminal 7 (<i>Input Terminal 7</i>)	002Bh:bit 6	ON	OFF	R
BI8	Drive MF Output 1 (<i>Multi Function Out 1</i>)	0020h:bit 5	ON	OFF	R
BI9	Drive MF Output 2 (<i>Multi Function Out 2</i>)	0020h:bit 6	ON	OFF	R
BI10	BYP DI-1 STAT	8781h:bit 0	ON	OFF	R
BI11	BYP DI-2 STAT	8781h:bit 1	ON	OFF	R
BI12	BYP DI-3 STAT	8781h:bit 2	ON	OFF	R
BI13	BYP DI-4 STAT	8781h:bit 3	ON	OFF	R
BI14	BYP DI-5 STAT	8781h:bit 4	ON	OFF	R
BI15	BYP DI-6 STAT	8781h:bit 5	ON	OFF	R
BI16	BYP DI-7 STAT	8781h:bit 6	ON	OFF	R
BI17	BYP DI-8 STAT	8781h:bit 7	ON	OFF	R
BI18	BYP DO-1 STAT	8782h:bit 0	ON	OFF	R
BI19	BYP DO-2 STAT	8782h:bit 1	ON	OFF	R
BI20	BYP DO-3 STAT	8782h:bit 2	ON	OFF	R
BI21	BYP DO-4 STAT	8782h:bit 3	ON	OFF	R
BI22	BYP DO-5 STAT	8782h:bit 4	ON	OFF	R
BI23	BYP DO-6 STAT	8782h:bit 5	ON	OFF	R
BI24	BYP DO-7 STAT	8782h:bit 6	ON	OFF	R
BI25	BYP DO-8 STAT	8782h:bit 7	ON	OFF	R
BI26	BYP DO-9 STAT	8783h:bit 0	ON	OFF	R
BI27	BYP DO-10 STAT	8783h:bit 1	ON	OFF	R

Object ID	Object Name (<i>Network Display, if Different</i>)	Modbus Reg.	Active Text	Inactive Text	PV Access
BI28	Drive Fault Status	004Bh:bit 7	ON	OFF	R
BI29	Drive Alarm Status	004Bh:bit 6	ON	OFF	R
BI30	Sys Alarm Status	8784h:bit 8	ON	OFF	R

Binary Output Objects

Object ID	Object Name	Modbus Reg.	Active Text	Inactive Text	PV Access
BO1	MF Output M1 - M2	0009h: Bit 0	ON	OFF	C
BO2	MF Output M3 - M4	0009h: Bit 1	ON	OFF	C
BO3	MF Output, MD-ME-MF	0009h: Bit 2	ON	OFF	C
BO4	Ref Sel:PI Setpoint	000Fh: Bit 1	ON	OFF	C
BO5	Ref Sel:Term S5 IN	0001h: Bit 8	ON	OFF	C
BO6	Ref Sel:Term S6 IN	0001h: Bit 9	ON	OFF	C
BO7	Ref Sel:Term S7 IN	0001h: Bit A	ON	OFF	C
BO8 <i>*1</i>	BYP DO-07 COMMAND	8403h: Bit 6	ON	OFF	C
BO9 <i>*1</i>	BYP DO-08 COMMAND	8403h: Bit 7	ON	OFF	C
BO10 <i>*1</i>	BYP DO-09 COMMAND	8403h: Bit 8	ON	OFF	C
BO11 <i>*1</i>	BYP DO-10 COMMAND	8403h: Bit 9	ON	OFF	C

*1 Set the corresponding Z2-xx parameter = 99 - *Not Used*.

Binary Value Objects

Object ID	Object Name (<i>Network Display, if Different</i>)	Modbus Reg.	Active Text	Inactive Text	PV Access
BV1	Not Used BV001	-	-	-	C
BV2	Not Used BV002	-	-	-	C
BV3	Drive External Fault Command (<i>Ext Fault Cmd</i>)	0001h: Bit 2	FAULT	OFF	C
BV4	Drive Fault Reset Command (<i>Fault Reset Cmd</i>)	0001h: Bit 3	RESET	OFF	C
BV5	Not Used BV005	-	-	-	C
BV6	Not Used BV006	-	-	-	C
BV7	Drive Multi-Function Input 3 Command (<i>MF Input 3 Cmd</i>)	0001h: Bit 6	ON	OFF	C
BV8	Drive Multi-Function Input 4 Command (<i>MF Input 4 Cmd</i>)	0001h: Bit 7	ON	OFF	C
BV9	Drive Multi-Function Input 5 Command (<i>MF Input 5 Cmd</i>)	0001h: Bit 8	ON	OFF	C
BV10	Drive Multi-Function Input 6 Command (<i>MF Input 6 Cmd</i>)	0001h: Bit 9	ON	OFF	C
BV11	Drive Multi-Function Input 7 Command (<i>MF Input 7 Cmd</i>)	0001h: Bit A	ON	OFF	C
BV12	Set Fault Contact Cmd (<i>Set Flt Contact Cmd</i>)	0009h: Bit 6&7	ENABLE	OFF	C
BV13	RUN-STOP	0020h: Bit 0	RUN	OFF	R

8 Network Communications

Object ID	Object Name (<i>Network Display, if Different</i>)	Modbus Reg.	Active Text	Inactive Text	PV Access
BV14	REV-FWD	0020h: Bit 1	REV	FWD	R
BV15	READY	0020h: Bit 2	READY	OFF	R
BV16	FAULT	0020h: Bit 3	FAULTED	OFF	R
BV17	Data Set Error	0020h: Bit 4	ERR	OFF	R
BV18	Overcurrent – Ground Fault (<i>Overcurrent– Gnd Fault</i>)	0021h: Bit 0	OC – GF	OFF	R
BV19	Main Circuit Overvoltage (<i>Main Ckt Overvoltage</i>)	0021h: Bit 1	OV	OFF	R
BV20	Drive Overload	0021h: Bit 2	OL2	OFF	R
BV21	Drive Overheat	0021h: Bit 3	OH1-OH2	OFF	R
BV22	Fuse Blown	0021h: Bit 5	PUF	OFF	R
BV23	PI Feedback Loss	0021h: Bit 6	FBL	OFF	R
BV24	External Fault	0021h: Bit 7	EF0 – EF	OFF	R
BV25	Hardware Error	0021h: Bit 8	CPF	OFF	R
BV26	Motor Overload – Overtorque (<i>Mtr OvrLd – OvrTorque</i>)	0021h: Bit 9	OL1 – OL3	OFF	R
BV27	Overspeed	0021h: Bit A	OS –DEV	OFF	R
BV28	Main Circuit Undervoltage (<i>Main Ckt Undervoltage</i>)	0021h: Bit B	UV	OFF	R
BV29	MCU, Control Power Supply Error (<i>MCU Cntrl Pwr Sy Err</i>)	0021h: Bit C	UV1-2-3	OFF	R
BV30	Output Phase Loss	0021h: Bit D	LF	OFF	R
BV31	Communication Error	0021h: Bit E	CE	OFF	R
BV32	Operator Disconnect	0021h: Bit F	OPR	OFF	R
BV33	Operating	002Ch: Bit 0	OPERATING	OFF	R
BV34	Zero Speed	002Ch: Bit 1	ON	OFF	R
BV35	Frequency Agree	002Ch: Bit2	ON	OFF	R
BV36	Desired Frequency Agree (<i>Desired Freq Agree</i>)	002Ch: Bit 3	ON	OFF	R
BV37	Frequency Detect 1	002Ch: Bit 4	ON	OFF	R
BV38	Frequency Detect 2	002Ch: Bit 5	ON	OFF	R
BV39	Drive Startup Complete (<i>Drv Startup Complete</i>)	002Ch: Bit 6	ON	OFF	R
BV40	Low Voltage Detect	002Ch: Bit 7	ON	OFF	R
BV41	Base Block	002Ch: Bit 8	ON	OFF	R
BV42	Frequency Reference Mode (<i>Frequency Ref Mode</i>)	002Ch: Bit 9	COM	LOCAL	R
BV43	Run Command Mode	002Ch: Bit A	COM	LOCAL	R
BV44	Over Torque Detect	002Ch: Bit B	ON	OFF	R
BV45	Frequency Reference Lost (<i>Frequency Ref Lost</i>)	002Ch: Bit C	ON	OFF	R
BV46	Retry Error	002Ch: Bit D	ON	OFF	R
BV47	Modbus Comms Error	002Ch: Bit E	ON	OFF	R
BV48	Modbus Timeout Error	002Ch: Bit F	ON	OFF	R
BV49	CRC Error	003Dh: Bit 0	ON	OFF	R

Object ID	Object Name (Network Display, if Different)	Modbus Reg.	Active Text	Inactive Text	PV Access
BV50	Invalid Data Length	003Dh: Bit 1	ON	OFF	R
BV51	Parity Error	003Dh: Bit 3	ON	OFF	R
BV52	Overrun Error	003Dh: Bit 4	ON	OFF	R
BV53	Framing Error	003Dh: Bit 5	ON	OFF	R
BV54	Timeout Error	003Dh: Bit 6	ON	OFF	R
BV55	Parameter Accept	Object activates an internal bit that performs desired object function	ON	OFF	W
BV56	Parameter Enter	Object activates an internal bit that performs desired object function	ON	OFF	W
BV57	Drive Comms Error	002Ch: Bit F	ON	OFF	R
BV58	Bypass Forward Run Cmd (BYP Run Fwd CMD)	0001h: Bit 0	ON	OFF	C
BV59	Bypass Reverse Run Cmd (BYP Run Rev CMD)	0001h: Bit 1	ON	OFF	C
BV60	Emergency Override Drive Reverse (Em Over DRV REV CMD)	8400h: Bit F	ON	OFF	C
BV61	Bypass Transfer to Bypass Cmd (BYP Xfer to BYP CMD)	8400h: Bit 3	ON	OFF	C
BV62	Emergency Override Bypass (Em Over BYPASS CMD)	8400h: Bit 4	ON	OFF	C
BV63	Emergency Override Drive Forward (Em Over DRV FWD CMD)	8400h: Bit 5	ON	OFF	C
BV64	Bypass Motor OR Select Command (BYP Mtr OR Sel CMD)	8400h: Bit 6	ON	OFF	C
BV65	Bypass Motor AND Select Command (BYP Mtr AND Sel CMD)	8400h: Bit 7	ON	OFF	C
BV66	Not Used BV066	-	ON	OFF	R
BV67	Not Used BV067	-	ON	OFF	R
BV68	Not Used BV068	-	ON	OFF	R
BV69	Bypass BYPASS Select Command (BYP BYPASS Sel CMD)	8400h: Bit C	ON	OFF	C
BV70	Bypass Fault Reset Command (BYP Fault Reset CMD)	8400h: Bit D	ON	OFF	C
BV71	Bypass External Fault Command (BYP Ext Fault CMD)	8400h: Bit E	ON	OFF	C
BV72	Bypass DI-01 Command (BYP DI-01 Command)	8402h: Bit 0	ON	OFF	C
BV73	Bypass DI-02 Command (BYP DI-02 Command)	8402h: Bit 1	ON	OFF	C
BV74	Bypass DI-03 Command (BYP DI-03 Command)	8402h: Bit 2	ON	OFF	C
BV75	Bypass DI-04 Command (BYP DI-04 Command)	8402h: Bit 3	ON	OFF	C
BV76	Bypass DI-05 Command (BYP DI-05 Command)	8402h: Bit 4	ON	OFF	C

8 Network Communications

Object ID	Object Name (<i>Network Display, if Different</i>)	Modbus Reg.	Active Text	Inactive Text	PV Access
BV77	Bypass DI-06 Command (<i>BYP DI-06 Command</i>)	8402h: Bit 5	ON	OFF	C
BV78	Bypass DI-07 Command (<i>BYP DI-07 Command</i>)	8402h: Bit 6	ON	OFF	C
BV79	Bypass DI-08 Command (<i>BYP DI-08 Command</i>)	8402h: Bit 7	ON	OFF	C
BV80	Bypass HAND Mode Status (<i>BYP HAND Mode Status</i>)	8784h: Bit 0	ON	OFF	R
BV81	Bypass OFF Mode Status (<i>BYP OFF Mode Status</i>)	8784h: Bit 1	ON	OFF	R
BV82	Bypass AUTO Mode Status (<i>BYP AUTO Mode Status</i>)	8784h: Bit 2	ON	OFF	R
BV83	Bypass DRIVE Mode Status (<i>BYP DRV Mode Status</i>)	8784h: Bit 3	ON	OFF	R
BV84	Bypass BYPASS Mode Status (<i>BYP BYPASS Mode Stat</i>)	8784h: Bit 4	ON	OFF	R
BV85	Bypass Emergency Run Bypass Status (<i>BYP Smk Prg BYP Stat</i>)	8784h: Bit 5	ON	OFF	R
BV86	Bypass Emergency Run Drive Fwd Status (<i>BYP Smk Prg DRV Stat</i>)	8784h: Bit 6	ON	OFF	R
BV87	Bypass Safety Status (<i>BYP Safety Status</i>)	8784h: Bit 7	ON	OFF	R
BV88	Bypass BAS Interlock Status (<i>BYP BAS Interlk Stat</i>)	8785h: Bit 0	ON	OFF	R
BV89	Bypass Run Status (<i>BYP RUN Status</i>)	8785h: Bit 1	ON	OFF	R
BV90	Bypass Fault Status (<i>BYP Fault Status</i>)	8785h: Bit 2	ON	OFF	R
BV91	Bypass Auto Transfer Status (<i>BYP Auto Xfer Status</i>)	8785h: Bit 3	ON	OFF	R
BV92	Bypass Remote Transfer Status (<i>BYP Remote Xfer Stat</i>)	8785h: Bit 4	ON	OFF	R
BV93	Bypass Energy Savings Status (<i>BYP Energy Save Stat</i>)	8785h: Bit 5	ON	OFF	R
BV94	Bypass Motor 1 Select Status (<i>BYP Motor 1 Sel Stat</i>)	8785h: Bit 6	ON	OFF	R
BV95	Bypass Motor 2 Select Status (<i>BYP Motor 2 Sel Stat</i>)	8785h: Bit 7	ON	OFF	R
BV96	Bypass Drive Fault Status (<i>BYP Drive Flt Status</i>)	8786h: Bit 0	ON	OFF	R
BV97	Bypass Safety Fault Status (<i>BYP Safety Flt Stat</i>)	8786h: Bit 1	ON	OFF	R
BV98	Bypass BAS Interlock Fault Status (<i>BYP BAS ILock Status</i>)	8786h: Bit 2	ON	OFF	R
BV99	Bypass External Fault Status (<i>BYP Ext Fault Stat</i>)	8786h: Bit 3	ON	OFF	R
BV100	Not Used BV100	-	-	-	R

Object ID	Object Name (Network Display, if Different)	Modbus Reg.	Active Text	Inactive Text	PV Access
BV101	Bypass Motor OL Status (BYP Motor OL Stat)	8786h: Bit 5	ON	OFF	R
BV102	Bypass Motor 1 OL Status (BYP Motor 1 OL Stat)	8786h: Bit 6	ON	OFF	R
BV103	Bypass Motor 2 OL Status (BYP Mtr 2 OL Stat)	8786h: Bit 7	ON	OFF	R
BV104	Bypass Input Phase Loss Status (BYP Input Phase Loss)	8787h: Bit 0	ON	OFF	R
BV105	Bypass Drive Comms Status (BYP Drive Comms)	8787h: Bit 2	ON	OFF	R
BV106	Bypass Loss of Load Status (BYP Loss OfLoad)	8787h: Bit 5	ON	OFF	R
BV107	Option Board on Drive Status (BYP Option Brd Comms)	8787h: Bit 4	ON	OFF	R

Device Object

The Device Object is the BACnet device to the network in this manual. The Device Object Instance ID, the Device Object Name, and the Device Object Location are configurable. Refer to [Table 8.5](#) for more information.

Table 8.5 Device Objects

Item	Description	Data Type
Device Object Instance ID	A unique internetwork-wide numerical value. To set this ID, set H5-14 [BACnet Device Obj ID LOW BITS] and H5-15 [BACnet Device Obj ID HIGH BITS].	22-bit value Range: 0 - 4, 194, 302
Device Object Name	A unique internetwork-wide character string that is writable from the BACnet network.	40-character strings
Device Object Location	Character field to describe the location of the device that is writable from the Bacnet network.	40-character strings

Note:

Any changes to the parameter settings and any new string written will not take effect until you de-energize the drive.

■ Accessing Drive Parameters and the Enter Command

Read Drive Parameters

To read the drive parameters that are not listed in the analog or digital objects, use AV29 and AV30 as shown in this procedure:

1. Write the desired Modbus register to AV29 in decimal value.
2. Read the decimal value at the given register from AV30.

For example, to read the Frequency Reference Upper Limit, read from parameter *d2-01* [Frequency Reference Upper Limit].

Parameter *d2-01* is located at Modbus register 0289H, which is decimal 649.

Set AV29 to “649.”

Read AV30 to get the value.

Write Drive Parameters

To write the drive parameters that are not listed in the analog or digital objects, use AV29, AV30, and BV55 or BV56 as shown in this procedure:

1. In AV29, write the desired Modbus register number in decimal format.
2. In AV30, write the value that you want to put into the register set in AV29 in decimal format.

At this point the value is written to the drive, but the location is pending.

If necessary, write in more values this way, the drive will accept these settings by one of two methods:

- Set BV55 to “ON” to move data to active memory.

- Set BV56 to “ON” to move data into active memory and save to non-volatile memory.

For example, to reset the KWH Monitor, write a value of “1” to parameter *o4-12 [kWh Monitor Initialization]*.

Parameter *o4-12* is located at Modbus register 0512 (Hex.), which is decimal 1298.

Set AV29 to “1298.”

Set AV30 to “1.”

Set BV55 to “ON.”

Enter Command

Enter Commands are only necessary to use AV29 and AV30 to access drive parameters. Enter commands are not necessary to read or write to the other BACnet objects.

This section gives information about the Enter command.

Types of Enter Commands

The drive supports two Enter commands shown in [Table 8.6](#).

Table 8.6 Types of Enter Commands

BACnet Object	Modbus Address (Hex.)	Description
BV55 (Write “ON”)	0910 (Write 0)	This updates the data on the RAM, but does not write data to the EEPROM. This process saves the parameter changes until you de-energize the drive.
BV56 (Write “ON”)	0900 (Write 0)	When you write parameter data to the EEPROM, you will enable the data on the RAM at the same time. This process saves the parameter changes until you de-energize the drive.

Note:

You can write the EEPROM to the drive a maximum of 100,000 times. Do not frequently execute the Enter command (0900 (Hex.)) that is written to EEPROM. The Enter command registers 0900 (Hex.) and 0910 (Hex.) are write-only. If these registers are read, the register address will not be applicable, but BACnet objects BV55 and BV56 can be read without error.

■ Self-Diagnostics

The bypass can use Self-Diagnostics to verify the hardware transceiver on the control circuit. Self-Diagnostics connects the transmission terminal to the reception terminal on the control circuit and transmits the data to itself to make sure that the bypass can communicate correctly.

Use this procedure to do Self-Diagnostics:

⚠ DANGER *Electrical Shock Hazard. Do not examine, connect, or disconnect wiring on an energized bypass. Before servicing, disconnect all power to the equipment and wait for the time specified on the warning label at a minimum. The internal capacitor stays charged after the bypass is de-energized. The charge indicator LED extinguishes when the DC bus voltage decreases below 50 VDC. When all indicators are OFF, remove the covers before measuring for dangerous voltages to make sure that the bypass is safe. If you do work on the bypass when it is energized, it will cause serious injury or death from electrical shock.*

1. Energize the bypass.
2. Set Z2-06 = 45 [*Digital Input 6 Function (TB2-6) - Serial Hardware Test (RS-485)*].
3. De-energize the bypass.
4. Disconnect the RS-485 terminals (TB3) before you do a communications hardware self-test.

- Connect a jumper between control circuit terminals TB2-6 and TB2-9 or TB2-10.

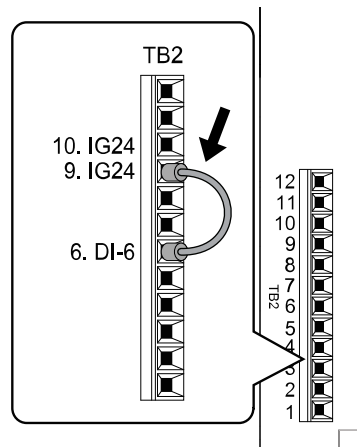

Figure 8.5 Self-Diagnostics Jumper Terminals

- Energize the bypass.
- When normal, the keypad will show *PASS [Serial Communication Test]*.

Note:

If there is an error, the keypad will show *CE [Serial Communication Error]*. Disconnect the bypass from the network and test the bypass again. If the error stays, there is a possible hardware problem. If there is no error, there is a possible network wiring problem.

- De-energize the bypass.
- Disconnect the jumper from Step 4. Set Z2-06 to its initial function.

Self-Diagnostics is complete and the bypass returns to its usual function.

■ BACnet Protocol Implementation Conformance Statement

- Date: 11/07/2022
- Vendor Name: Yaskawa
- Product Name: AC Bypass Control
- Product Model Number: FP60U
- Application Software Version: VST8005xx
- Firmware Revision: 2.01
- BACnet Protocol Revision: 14
- Product Description:

The Yaskawa FP605 Bypass is a high performance product specifically designed for commercial building automation applications. The Yaskawa BACnet feature connects the FP605 Bypass to a standard BACnet MS/TP network. These products may be fully controlled and monitored over BACnet. All Bypass and drive parameters are available for reading and writing.
- BACnet Standardized Device Profile (Annex L):
 - BACnet Cross-Domain Advanced Operator Workstation (B-XAWS)
 - BACnet Advanced Operator Workstation (B-AWS)
 - BACnet Operator Workstation (B-OWS)
 - BACnet Operator Display (B-OD)
 - BACnet Advanced Life Safety Workstation (B-ALSWS)
 - BACnet Life Safety Workstation (B-LSWS)
 - BACnet Life Safety Annunciator Panel (B-LSAP)
 - BACnet Advanced Access Control Workstation (B-AACWS)
 - BACnet Access Control Workstation (B-ACWS)
 - BACnet Access Control Security Display (B-ACSD)
 - BACnet Building Controller (B-BC)
 - BACnet Advanced Application Controller (B-AAC)
 - BACnet Application Specific Controller (B-ASC)
 - BACnet Smart Actuator (B-SA)

- BACnet Smart Sensor (B-SS)
- BACnet Advanced Life Safety Controller (B-ALSC)
- BACnet Life Safety Controller (B-LSC)
- BACnet Advanced Access Control Controller (B-AACC)
- BACnet Access Control Controller (B-ACC)
- BACnet Router (B-RTR)
- BACnet Gateway (B-GW)
- BACnet Broadcast Management Device (B-BBMD)
- BACnet Access Control Door Controller (B-ACDC)
- BACnet Access Control Credential Reader (B-ACCR)
- BACnet General (B-GENERAL)
- List all BACnet Interoperability Building Blocks Supported (Annex K):
 - Data Sharing-ReadProperty-B (DS-RP-B)
 - Data Sharing-WriteProperty-B (DS-WP-B)
 - Data Sharing-ReadPropertyMultiple-B (DS-RPM-B)
 - Data Sharing-WritePropertyMultiple-B (DS-WPM-B)
 - Data Sharing-Change Of Value-B (DS-COV-B)
 - Data Sharing-Change Of Value Property-B (DS-COVP-B)
 - Device Management-Dynamic Device Binding-B (DM-DDB-B)
 - Device Management-Dynamic Object Binding-B (DM-DOB-B)
 - Device Management-DeviceCommunicationControl-B (DM-DCC-B)
 - Device Management-ReinitializeDevice-B (DM-RD-B)
 - Device Management-TimeSynchronization-B (DM-TS-B)
- Segmentation Capability:
 - Able to transmit segmented messages / Window Size:
 - Able to receive segmented messages / Window Size:
- Standard Object Types Supported:

Object Types	Descriptions
Device Object	Optional Writeable: – Max_Info_Frames – Max_Master
Analog Input Object	Optional properties supported: – COV_Increment Optional Writeable: – COV_Increment - supported on various instances
Analog Output Object	-
Analog Value Object	Optional properties supported: – COV_Increment Optional Writeable: – COV_Increment - supported on various instances
Binary Input Object	-
Binary Output Object	-
Binary Value Object	-

- Data Link Layer Options:
 - ARCNET (ATA 878.1), 2.5 Mb. (Clause 8)
 - ARCNET (ATA 878.1), EIA-485 (Clause 8), baud rate(s):
 - BACnet IP, (Annex J)
 - BACnet IP, (Annex J), BACnet Broadcast Management Device (BBMD)
 - BACnet IP, (Annex J), Network Address Translation (NAT Traversal)

- BACnet IPv6, (Annex U)
- BACnet IPv6, (Annex U), BACnet Broadcast Management Device (BBMD)
- BACnet/ZigBee (Annex O)
- Ethernet, ISO 8802-3 (Clause 7)
- LonTalk, ISO/IEC 14908.1 (Clause 11), medium:
 - MS/TP master (Clause 9), baud rate(s): 9600, 19200, 38400, 76800
 - MS/TP slave (Clause 9), baud rate(s)
 - Point-To-Point, EIA 232 (Clause 10), baud rate(s):
 - Point-To-Point, modem, (Clause 10), baud rate(s):
 - Other:
- Device Address Binding:

Is static device binding supported? (This is currently necessary for two-way communication with MS/TP slaves and certain other devices.) Yes No
- Networking Options:
 - Router, Clause 6 - List all routing configurations, e.g., ARCNET-Ethernet, Ethernet-MS/TP, etc.
 - Annex H, BACnet Tunneling Router over IP
- Character Sets Supported:

Indicating support for multiple character sets does not imply that they can all be supported simultaneously.

 - ISO 10646 (UTF-8)
 - IBM/Microsoft DBCS
 - ISO 8859-1
 - ISO 10646 (UCS-2)
 - ISO 10646 (UCS-4)
 - JIS X 0208
- Gateway Options:

If this product is a communication gateway, describe the types of non-BACnet equipment/networks(s) that the gateway supports:

Not supported

If this product is a communication gateway which presents a network of virtual BACnet devices, a separate PICS shall be provided that describes the functionality of the virtual BACnet devices. That PICS shall describe a superset of the functionality of all types of virtual BACnet devices that can be presented by the gateway.
- Network Security Options:
 - Non-secure Device - is capable of operating without BACnet Network Security
 - Secure Device - is capable of using BACnet Network Security (NS-SD BIBB)
 - Multiple Application-Specific Keys
 - Supports encryption (NS-ED BIBB)
 - Key Server (NS-KS BIBB)

◆ Other Embedded Communication Protocols

For detailed information about:

- APOGEE FLN (P1) Communications
- Metasys N2 Communications
- MEMOBUS/Modbus Communications

Refer to the FP605 Bypass Technical Reference (SIEPYAIF6B01).

9 Standards Compliance

This chapter gives information about how to make the machines and devices that use this product comply with UL standards, seismic standards, and European standards.

◆ Section Safety

⚠ DANGER *Electrical Shock Hazard. Do not examine, connect, or disconnect wiring on an energized bypass. Before servicing, disconnect all power to the equipment and wait for the time specified on the warning label at a minimum. The internal capacitor stays charged after the bypass is de-energized. The charge indicator LED extinguishes when the DC bus voltage decreases below 50 VDC. When all indicators are OFF, remove the covers before measuring for dangerous voltages to make sure that the bypass is safe. If you do work on the bypass when it is energized, it will cause serious injury or death from electrical shock.*

⚠ WARNING *Electrical Shock Hazard. Do not operate the bypass when covers are missing. Replace covers and shields before you operate the bypass. Use the bypass only as specified by the instructions. Some figures in this section include bypasses without covers or safety shields to more clearly show the inside of the bypass. If covers or safety shields are missing from the bypass, it can cause serious injury or death.*

⚠ WARNING *Electrical Shock Hazard. Always ground the motor-side grounding terminal. If you do not ground the equipment correctly, it can cause serious injury or death if you touch the motor case.*

⚠ WARNING *Electrical Shock Hazard. Do not remove covers or touch circuit boards while the bypass is energized. If you touch the internal components of an energized bypass, it can cause serious injury or death.*

⚠ WARNING *Electrical Shock Hazard. Only let approved personnel install, wire, maintain, examine, replace parts, and repair the bypass. If personnel are not approved, it can cause serious injury or death.*

⚠ WARNING *Electrical Shock Hazard. Do not wear loose clothing or jewelry when you do work on the bypass. Tighten loose clothing and remove all metal objects, for example watches or rings. Loose clothing can catch on the bypass and jewelry can conduct electricity and cause serious injury or death.*

⚠ WARNING *Electrical Shock Hazard. Do not modify the bypass body, drive body, bypass circuitry, or drive circuitry. Modifications to bypass and drive body and circuitry can cause serious injury or death, will cause damage to the bypass and drive, and will void the warranty. Yaskawa is not responsible for modifications of the product made by the user.*

⚠ WARNING *Fire Hazard. Tighten all terminal screws to the correct tightening torque. Connections that are too loose or too tight can cause incorrect operation and damage to the bypass. Incorrect connections can also cause death or serious injury from fire.*

⚠ WARNING *Fire Hazard. Tighten screws at an angle in the specified range shown in this manual. If you tighten the screws at an angle not in the specified range, you can have loose connections that can cause damage to the terminal block or start a fire and cause serious injury or death.*

⚠ WARNING *Damage to Equipment. Do not apply incorrect voltage to the main circuit of the bypass. Operate the bypass in the specified range of the input voltage on the nameplate. Voltages that are higher than the permitted nameplate tolerance can cause damage to the bypass.*

⚠ WARNING *Fire Hazard. Do not put flammable or combustible materials on top of the bypass and do not install the bypass near flammable or combustible materials. Attach the bypass to metal or other noncombustible material. Flammable and combustible materials can start a fire and cause serious injury or death.*

⚠ WARNING *Crush Hazard. Wear eye protection when you do work on the bypass. If you do not use correct safety equipment, it can cause serious injury or death.*

⚠ WARNING *Electrical Shock Hazard. After the bypass blows a fuse or trips a GFCI, do not immediately energize the bypass or operate peripheral devices. Wait for the time specified on the warning label at a minimum and make sure that all indicators are OFF. Then check the wiring and peripheral device ratings to find the cause of the problem. If you do not know the cause of the problem, contact Yaskawa before you energize the bypass or peripheral devices. If you do not fix the problem before you operate the bypass or peripheral devices, it can cause serious injury or death.*

NOTICE *Damage to Equipment. When you touch the bypass, drive, and circuit boards, make sure that you observe correct electrostatic discharge (ESD) procedures. If you do not follow procedures, it can cause ESD damage to the drive and bypass circuitry.*

NOTICE *Do not break the electrical connection between the bypass and the motor when the bypass is outputting voltage. Incorrect equipment sequencing can cause damage to the bypass.*

NOTICE *Make sure that all connections are correct after you install the bypass and connect peripheral devices. Incorrect connections can cause damage to the bypass.*

Note:

Do not use unshielded cable for control wiring. Use shielded, twisted-pair wires and ground the shield to the ground terminal of the bypass. Unshielded wire can cause electrical interference and unsatisfactory system performance.

◆ UL Standards



Figure 9.1 UL/cUL Mark

The UL/cUL Mark identifies that this product conforms to rigid safety standards. This mark appears on products in the United States and Canada. It shows UL approval, which identifies that the product complies with safety standards after careful inspection and assessment. You must use UL Listed or UL Recognized parts for all primary components that are built into electrical equipment that has UL approval.

This product has been tested in accordance with UL standard UL508A, and has been verified to be in compliance with UL standards.

Machines and devices integrated with this product must satisfy the following conditions for compliance with UL standards.

■ Area of Use

Install this product in a location with Overvoltage Category III and pollution degree 2 or less.

Ambient Temperature Setting

Maintain the ambient temperature within the following ranges according to the enclosure type.

- UL Type 1: -10 °C to +40 °C (14 °F to 104 °F)
- UL Type 12: -10 °C to +40 °C (14 °F to 104 °F)
- UL Type 3R: -10 °C to +40 °C (14 °F to 104 °F)

◆ Seismic Standards

Yaskawa bypasses that have the certification label in [Figure 9.2](#) are capable of structurally and operationally withstanding the seismic response criteria as defined in the International Building Code (IBC), ASCE7, and California Department of Health Care Access and Information (HCAI).

The models in this section were tested in compliance with AC-156 to meet the IBC seismic certification as shown on the certification labels.

<p>Seismic Certification HCAI Preapproval: OSP-0687 CoC: VMA-53982-01C Product Type: General Purpose Bypass VFD Product Models: FP605 Bypass Panel Manufacturer: Yaskawa America, Inc Manufacturer's ID: 000000 Mounting Configuration: Rigid or Flexible Wall Mount Applicable Building Codes: IBC 2018, 2021 Perf Spec: $S_{DS} \leq 2.00g$, $z/h \leq 1.0$, $I_p \leq 1.5$ $S_{DS} \leq 2.50g$, $z/h = 0$ Refer to Seismic Install Manual TOEPYASUP18</p>	
---	--

Figure 9.2 Seismic Certification Label Example for Bypasses

■ IBC/HCAI Seismic Mounting Requirements for FP605 Bypass

Use the attachment hardware in [Table 9.1](#) to [Table 9.3](#) depending on your enclosure type to install your bypass to meet the IBC/HCAI seismic mounting requirements. Some models require the use of two #8-32 screws, at least 3/8" long, to secure the door.

UL Type 1 Enclosures

Table 9.1 UL Type 1 Enclosed Bypass Attachment Methods and Hardware Specifications

Bypass Model F6B1	Attachment Method	Attachment Hardware		
		Quantity	Specifications	
D004 to D016 D024 to D114 <i>*1</i> A004 to A015 A022 to A104 <i>*1</i> B002 to B014 B021 to B124 <i>*1</i>	Direct to Steel	4	Anchor Material	ASTM A307
			Anchor Diameter	3/8 in
	Direct to Concrete <i>*2</i>	4	Anchor Material	Hilti KH-EZ Screw Anchor
			Anchor Diameter	3/8 in
			Minimum Embedment	3.25 in
			Critical Edge Distance	6.0 in
CMU	1500 PSI CMU with 2000 PSI grout			
D143, D169 <i>*1</i> A130, A154 <i>*1</i> B156 <i>*1</i>	Direct to Steel	4	Anchor Material	ASTM A307
			Anchor Diameter	1/2 in
	Direct to Concrete <i>*2</i> (IBC 2021 Excluded)	4	Anchor Material	Hilti HIT-HY 270 + HAS-V-36
			Anchor Diameter	1/2 in
			Minimum Embedment	4.50 in
			Critical Edge Distance	20.0 in
CMU	1500 PSI CMU with 2000 PSI grout			

*1 These models also require the use of two #8-32 seismic door securing screws.

*2 Refer to [Concrete Masonry Attachment Detail on page 223](#) for Direct to Concrete installations.

UL Type 12 Enclosures

Table 9.2 UL Type 12 Enclosed Bypass Attachment Methods and Hardware Specifications

Bypass Model F6B2	Attachment Method	Attachment Hardware		
		Quantity	Specifications	
D004 to D059 A004 to A054 B002 to B065	Direct to Steel	4	Anchor Material	ASTM A307
			Anchor Diameter	3/8 in
	Direct to Concrete <i>*1</i>	4	Anchor Material	Hilti KH-EZ Screw Anchor
			Anchor Diameter	3/8 in
			Minimum Embedment	3.25 in
			Critical Edge Distance	6.0 in
CMU	1500 PSI CMU with 2000 PSI grout			
D074 to D169 A068 to A154 B077 to B156	Direct to Steel	4	Anchor Material	ASTM A307
			Anchor Diameter	1/2 in
	Direct to Concrete <i>*1</i> (IBC 2021 Excluded)	4	Anchor Material	Hilti HIT-HY 270 + HAS-V-36
			Anchor Diameter	1/2 in
			Minimum Embedment	4.50 in
			Critical Edge Distance	20.0 in
CMU	1500 PSI CMU with 2000 PSI grout			

*1 Refer to [Concrete Masonry Attachment Detail on page 223](#) for Direct to Concrete installations.

UL Type 3R Enclosures

Table 9.3 UL Type 3R Enclosed Bypass Attachment Methods and Hardware Specifications

Bypass Model F6B3	Attachment Method	Attachment Hardware		
		Quantity	Specifications	
D016 to D059 A015 to A054 B004 to B065	Direct to Steel	4	Anchor Material	ASTM A307
			Anchor Diameter	3/8 in
	Direct to Concrete *1	4	Anchor Material	Hilti KH-EZ Screw Anchor
			Anchor Diameter	3/8 in
			Minimum Embedment	3.25 in
			Critical Edge Distance	6.0 in
CMU	1500 PSI CMU with 2000 PSI grout			
D074 to D114 A068 to A104 B077 to B124	Direct to Steel	4	Anchor Material	ASTM A307
			Anchor Diameter	3/8 in
	Direct to Concrete *1 (IBC 2021 Excluded)	4	Anchor Material	Hilti HIT-HY 270 + HAS-V-36
			Anchor Diameter	3/8 in
			Minimum Embedment	4.50 in
			Critical Edge Distance	20.0 in
CMU	1500 PSI CMU with 2000 PSI grout			
D143, D169 A130, A154 B156	Direct to Steel	4	Anchor Material	ASTM A307
			Anchor Diameter	1/2 in
	Direct to Concrete *1 (IBC 2021 Excluded)	4	Anchor Material	Hilti HIT-HY 270 + HAS-V-36
			Anchor Diameter	1/2 in
			Minimum Embedment	4.50 in
			Critical Edge Distance	20.0 in
CMU	1500 PSI CMU with 2000 PSI grout			

*1 Refer to [Concrete Masonry Attachment Detail on page 223](#) for Direct to Concrete installations.

Concrete Masonry Attachment Detail

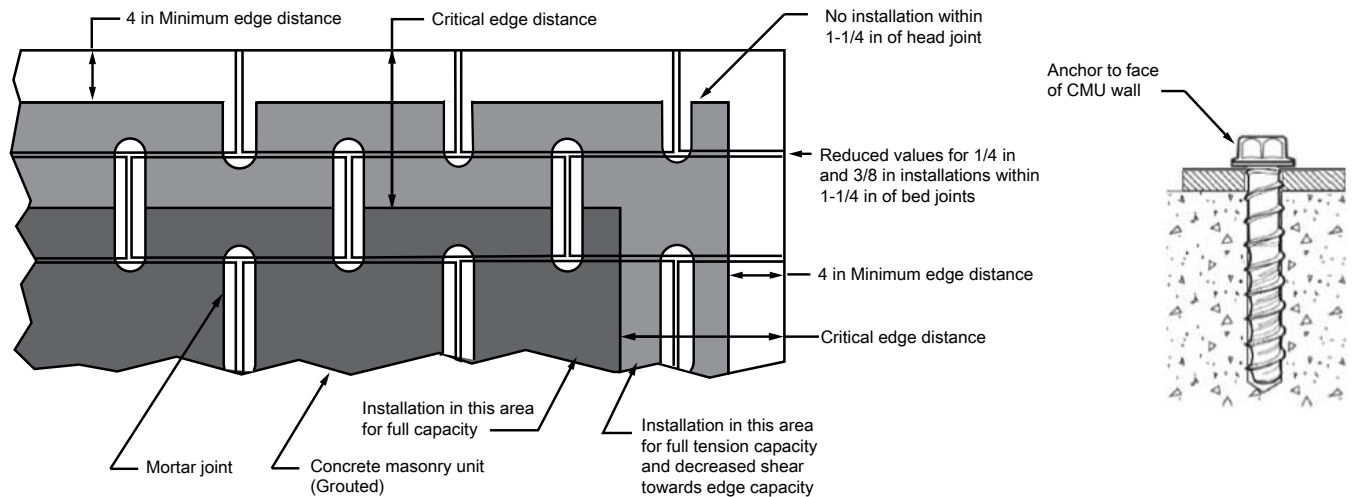

Note:

Anchorage Installation is restricted to shaded areas as per ESR 3056.

10 Disposal

◆ Section Safety

⚠ WARNING *Electrical Shock Hazard. De-energize the bypass and wait 5 minutes minimum until the Charge LED turns off. Remove the front cover and terminal cover to do work on wiring, circuit boards, and other parts. Use terminals for their correct function only. Incorrect wiring, incorrect ground connections, and incorrect repair of protective covers can cause death or serious injury.*

⚠ WARNING *Electrical Shock Hazard. Only let approved personnel install, wire, maintain, examine, replace parts, and repair the bypass. If personnel are not approved, it can cause serious injury or death.*

⚠ WARNING *Electrical Shock Hazard. Do not wear loose clothing or jewelry when you do work on the bypass. Tighten loose clothing and remove all metal objects, for example watches or rings. Loose clothing can catch on the bypass and jewelry can conduct electricity and cause serious injury or death.*

⚠ WARNING *Fire Hazard. Handle keypad batteries properly. Do not charge the battery or disassemble the keypad. If the battery explodes, it can cause a fire.*

⚠ WARNING *Fire Hazard. Do not disassemble batteries. Do not expose batteries to heat or fire. If the battery explodes, it can cause a fire.*

⚠ WARNING *Crush Hazard. Wear eye protection when you do work on the bypass. If you do not use correct safety equipment, it can cause serious injury or death.*

⚠ WARNING *Crush Hazard. Only approved personnel can operate a crane or hoist to move the bypass. If unapproved personnel operate a crane or hoist, it can cause serious injury or death from falling equipment.*

⚠ WARNING *Crush Hazard. Use a crane or hoist to move large bypasses when necessary. If you try to move a large bypass without a crane or hoist, it can cause serious injury or death.*

⚠ CAUTION *Crush Hazard. Tighten terminal cover screws and hold the case safely when you move the bypass. If the bypass or covers fall, it can cause moderate injury.*

NOTICE *Damage to Equipment. The keypad battery stays in use after you de-energize the bypass. When you will keep the bypass de-energized for long periods of time, remove the battery from the keypad. When the expected life of the battery is complete, replace the battery immediately. A dead battery in the keypad can leak and cause damage to the keypad and bypass.*

◆ Disposal Instructions

Correctly discard the drive, packing material, battery, and microSD card as specified by regional, local, and municipal laws and regulations for this product. (Example: European Waste 16 02 14)

Note:

- Remove the battery and microSD card from the keypad before you discard the drive.
- You cannot recycle the battery. Discard used batteries as specified by the battery manufacturer.
- Customers are responsible for microSD card data protection. PC functions that format and delete the data may not be sufficient to fully erase the microSD card data.
Yaskawa recommends that customers physically destroy the microSD card in a shredder or use data wipe software to fully erase the card.

◆ WEEE Directive

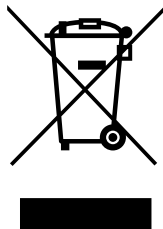

The wheeled bin symbol on this product, its manual, or its packaging identifies that you must recycle it at the end of its product life.

You must discard the product at an applicable collection point for electrical and electronic equipment (EEE). Do not discard the product with usual waste.

Index

A

Adjustment of control functionality	70
AFBL	100
AL02	100
AL03	100
AL09	100
AL13	100
AL16	100
AL17	100
AL18	100
Alarm	72, 99
ALM indicator	59
Altitude	
Environment	16
Ambient humidity	16
Ambient Temperature Setting	16
APOGEE FLN (P1)	219
AuDis	100
AuFbl	100
AUTO indicator	59, 61
AUTO key	59
AUTO LED	61
Auto-Tuning	69
Induction Motor	69
Precautions	69
Rotational Auto-Tuning Precautions	70
Stationary Auto-Tuning for Line-to-Line Resistance precautions	70
Stationary Auto-Tuning Precautions	70
Stator resistance Auto-Tuning precautions	70
Auto-Tuning Error	72, 111
AUXFB	
Fault	85
Minor Fault	100

B

BACnet	
Communication specifications	202
Enter command	216
Self-diagnosis	216
bAT	
Fault	85
Minor Fault	100
Battery	
Disposal	224
bb	100
bCE	
Fault	85
Minor Fault	100
Bu-Fb	100
BuDif	100
BuFbl	100
bUS	
Fault	85
Minor Fault	100
bUSy	101
Bypass control circuit terminals	
Wiring	41

C

CALL	101
CE	
Fault	86
Minor Fault	101
CoF	86
Connection diagram	
Connection diagram	29
Control circuit terminals	
Wiring procedure for terminal block	46, 54
Copy Function Error	72, 113
CPF00	86
CPF01	86
CPF02	86
CPF03	86
CPF06	86
CPF07	86
CPF08	86
CPF11	86
CPF12	87
CPF13	87
CPF14	87
CPF16	87
CPF17	87
CPF18	87
CPF19	87
CPF20	87
CPF21	87
CPF22	87
CPF23	87
CPF24	87
CPF26	87
CPF27	87
CPF28	87
CPF29	87
CPF30	87
CPF31	88
CPF32	88
CPF33	88
CPF34	88
CPF35	88
CPF36	88
CPF37	88
CPF38	88
CPF39	88
CPyE	113
CrST	102
CSEr	113
CyPo	102

D

dEv	
Fault	88
dFPS	113
Diagnosing and Resetting Faults	115
DIFF	
Fault	88
Minor Fault	102
Disposal	
Battery	224
Drive	224
microSD card	224
Packing material	224

dnE	102
Drive	
Disposal	224
Rating (208 V)	116
Rating (240 V)	117
Rating (480 V)	119
Drive control circuit terminals	
Wiring	47
Drive cooling fans	128
Drive watt loss	123
dv7	88
E	
EF	102
EF0	
Fault	88
Minor Fault	102
EF1	
Fault	88
Minor Fault	102
EF2	
Fault	88
Minor Fault	102
EF3	
Fault	89
Minor Fault	102
EF4	
Fault	89
Minor Fault	102
EF5	
Fault	89
Minor Fault	102
EF6	
Fault	89
Minor Fault	103
EF7	
Fault	89
Minor Fault	103
EF8	
Fault	89
End1	111
End2	111
End3	111
End4	111
End5	111
End6	111
End7	111
Enter command	216
EOF	103
EOR	103
EP24v	103
Er-01	111
Er-02	111
Er-03	112
Er-04	112
Er-05	112
Er-08	112
Er-09	112
Er-12	112
Er-13	112
Er-18	113
Er-25	113
Err	89

Error Code List	73, 80
F	
FAn1	89
Fault	72, 85
Fault Code List	73, 80
Fault Reset	115
FB02	89
FB03	90
FB05	90
FB06	90
FB07	90
FB08	91
FB09	91
FB10	91
FB13	91
FB15	91
FB16	91
FB17	91
FB18	91
FB26	91
FB27	91
FB28	91
FB30	91
FDBKL	
Fault	92
Minor Fault	103
Fine tuning	70
FIRE_ST	103
FLGT	103
FREEZ_ST	103
FR<MS	103
FR<TH	104
G	
GF	92
Ground	
Drive	38
H	
HAND indicator	59, 61
HAND LED	61
HCA	104
HFB	92
HIAUX	
Fault	92
Minor Fault	104
HIFB	104
How to read catalog codes	13
Humidity	
Environment	16
HWL	104
I	
iFEr	113
Induction Motor	
Auto-Tuning	69
Inspection	128
Installation	
Front cover	22
Terminal cover	22
Installation environment	16
INTLK	104
K	
Keypad	

Meaning of indicators.....	59	oFA10.....	94
Method of operation.....	59	oFA11.....	94
L		oFA12.....	94
L24v.....	104	oFA13.....	94
LCP.....	104	oFA14.....	94
LF.....	92	oFA15.....	94
LF2.....	92	oFA16.....	94
LFB.....	92	oFA17.....	94
LOAUX		oFA30.....	94
Fault.....	92	oFA31.....	94
Minor Fault.....	104	oFA32.....	94
LOFB.....	104	oFA33.....	94
LoG.....	104	oFA34.....	94
LOP		oFA35.....	95
Fault.....	92	oFA36.....	95
Minor Fault.....	105	oFA37.....	95
LOW_SUCT.....	105	oFA38.....	95
LSP.....	105	oFA39.....	95
LT-1.....	105	oFA40.....	95
LT-2.....	105	oFA41.....	95
LT-3.....	105	oFA42.....	95
LT-4.....	105	oFA43.....	95
LWL.....	105	OFF key.....	59
LWT.....	105	oH	
M		Fault.....	95
Main circuit terminals		Minor Fault.....	105
Line voltage drop.....	34	oH1.....	95
Wire gauge.....	34	oH2.....	105
Wiring.....	33	oH3	
Wiring procedure for terminal block.....	39	Fault.....	95
MEMOBUS		Minor Fault.....	106
Self-diagnosis.....	216	oH4.....	96
MEMOBUS/Modbus Communications.....	219	oL1.....	96
Metasys		oL2.....	97
Self-diagnosis.....	216	oL3	
Metasys N2 Communications.....	219	Fault.....	97
microSD card		Minor Fault.....	106
Disposal.....	224	oL4	
Insertion slot.....	59	Fault.....	97
Minor Fault.....	72, 99	Minor Fault.....	106
Minor Fault Code List.....	73, 80	oL7.....	97
Modbus		oPE01.....	108
Self-diagnosis.....	216	oPE02.....	108
Motor		oPE03.....	108
Wiring.....	33	oPE05.....	109
Wiring distance.....	38	oPE07.....	109
N		oPE08.....	110
Nameplate.....	12–13	oPE09.....	110
ndAT.....	113	oPE10.....	110
NMS		oPE11.....	110
Fault.....	93	oPE16.....	110
Minor Fault.....	105	oPE29.....	110
O		oPE34.....	110
oC.....	93	oPE36.....	110
OD		oPr.....	97
Fault.....	93	Options.....	124–125
Minor Fault.....	105	ov	
oFA00.....	93	Fault.....	97
oFA01.....	94	Minor Fault.....	106
oFA05.....	94	OV_PRESS.....	106
oFA06.....	94	ov2.....	98
		ovEr.....	106

P		
PA1	106	
Parameter Setting Errors	72, 108	
PASS	106	
PC		
Connection procedure.....	56	
PE1	98	
PE2	98	
Peripheral Devices	124–125	
PF.....	98, 106	
Power loss	123	
PSE		
Fault	98	
R		
Rating (208 V)		
Drive	116	
Rating (240 V)		
Drive	117	
Rating (480 V)		
Drive	119	
rdEr.....	113	
Remove		
Front cover	22	
Terminal cover.....	22	
RESET key.....	59	
RJ-45 connector	59	
Rotational Auto-Tuning		
Induction Motor	69	
Precautions	70	
S		
SAFE.....	107	
SC	98	
SCF.....	99	
Schematic	29	
SE	107	
SEr	99	
SMK_ALARM	107	
Stationary Auto-Tuning		
Induction Motor	69	
Precautions	70	
Stationary Auto-Tuning for Line-to-Line Resistance	69	
Precautions	70	
Stator resistance Auto-Tuning		
Precautions	70	
STo	107	
SToF	107	
T		
Temperature		
Environment.....	16	
Terminal function selection		
Terminal A1	55	
Terminal A2	55	
Terminal A3	55	
Terminal AM.....	56	
Terminal FM	56	
Test run		
Fine tuning	70	
Tightening torque		
Main circuit terminals.....	34	
TiM		
Fault	99	
Minor Fault.....	107	
Troubleshooting		
Code Displayed	73, 80	
TrPC.....	107	
U		
UL3		
Fault	99	
Minor Fault.....	107	
UL4		
Fault	99	
Minor Fault.....	107	
UL6		
Fault	99	
Minor Fault.....	107	
USB port	59	
Connecting a PC.....	56	
Uv	107	
Uv1.....	99	
Uv2.....	99	
Uv3.....	99	
V		
vAEr	113	
VBRATION.....	108	
vFyE	113	
Vibration-resistant.....	16	
VLTS.....	99	
W		
WEEE.....	224	
Wire gauge		
Main circuit terminals.....	34	
Voltage drop.....	34	
Wiring		
Control circuit terminal block	46, 54	
Control circuit terminals.....	41, 47	
Main circuit terminal block	39	
Main circuit terminals.....	33	
Motor.....	33	
Wiring diagram		
Wiring diagram	29	
Wiring distance		
Drive and motor	38	

Revision History

Date of Publication	Revision Number	Section	Revised Content
February 2023	-	-	First Edition. This manual supports bypass software version VST800560.

YASKAWA

FP605 ENCLOSED BYPASS INSTALLATION & STARTUP

YASKAWA AMERICA, INC.

2121, Norman Drive South, Waukegan, IL
60085, U.S.A.
+1-800-YASKAWA (927-5292)
<http://www.yaskawa.com>

DRIVE CENTER (INVERTER PLANT)

2-13-1, Nishimiyaichi, Yukuhashi, Fukuoka,
824-8511, Japan
Phone: +81-930-25-2548
<https://www.yaskawa.co.jp>

YASKAWA EUROPE GmbH

Hauptstr. 185, 65760 Eschborn, Germany
Phone: +49-6196-569-300
E-mail: support@yaskawa.eu.com
<http://www.yaskawa.eu.com>

YASKAWA ELÉTRICO DO BRASIL LTDA.

777, Avenida Piraporinha, Diadema, São
Paulo, 09950-000, Brasil
Phone: +55-11-3585-1100
<http://www.yaskawa.com.br>

In the event that the end user of this product is to be the military and said product is to be employed in any weapons systems or the manufacture thereof, the export will fall under the relevant regulations as stipulated in the Foreign Exchange and Foreign Trade Regulations. Therefore, be sure to follow all procedures and submit all relevant documentation according to any and all rules, regulations and laws that may apply.

Specifications are subject to change without notice for ongoing product modifications and improvements.

Original instructions.

© 2023 YASKAWA America, Inc.

YASKAWA America, Inc.

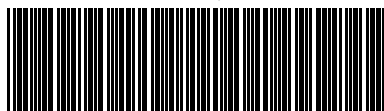

TOEPYAIF6B01

TOEPYAIF6B01
Revision: A <0>-0
February 2023
Published in USA
2023_YAI