

- Read and follow the safety and installation procedures in the Installation & Primary Operation (TOEPC7106171F) manual packaged with the drive.
- When you install an SI-P3, SI-S3, or SI-N3 communication option, you must also use the applicable LED label for your option. LED labels are included with the Installation & Primary Operation (TOEPC7106171F) manual.

1 Confirm the Drive and Motor Specifications

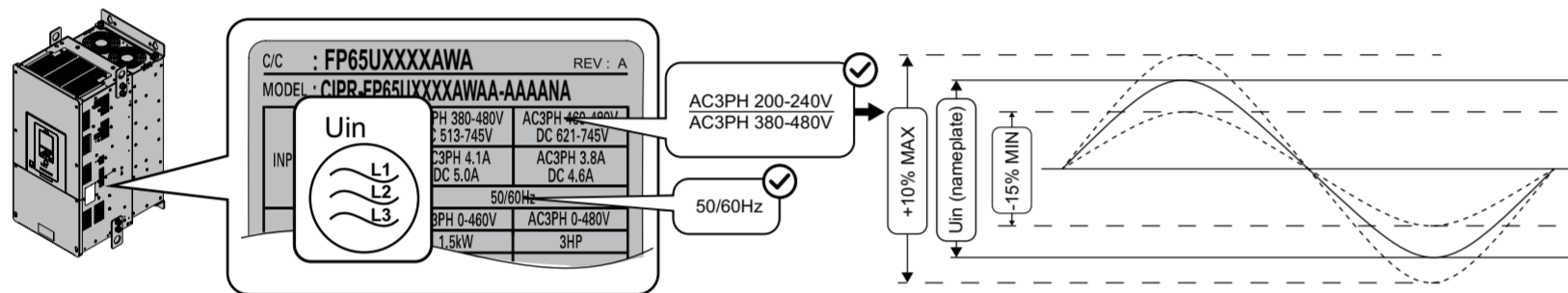

2 Collect the Required Tools and Equipment

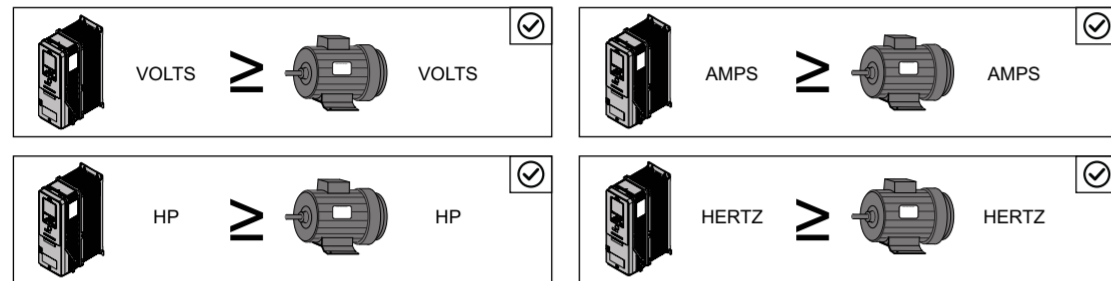
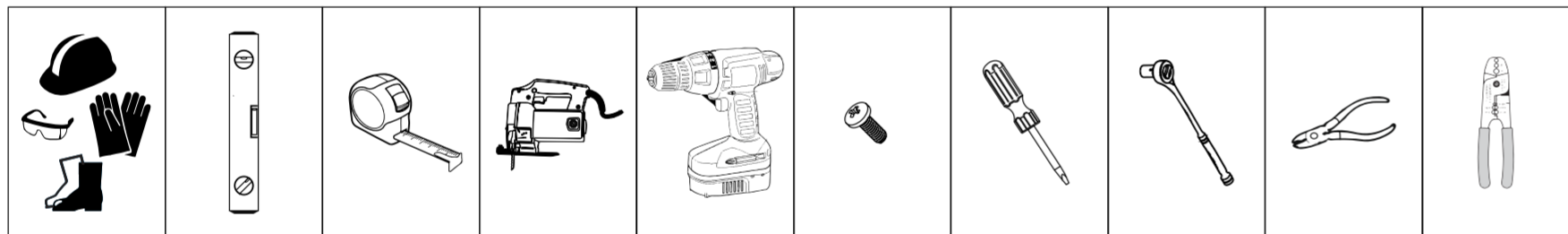

3 Confirm the Correct Drive Installation Environment

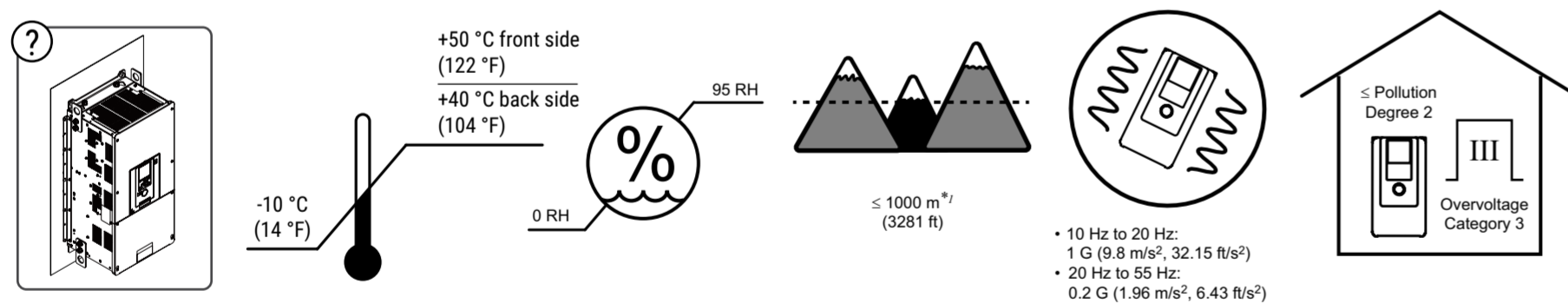

*1 Derate the output current by 1% for each 100 m (328 ft) to install the drive in altitudes between 1000 m to 4000 m (3281 ft to 13123 ft). Refer to the Technical Reference (SIEPC7106171F) for derating information.

4 Confirm the Drive and Motor Specifications

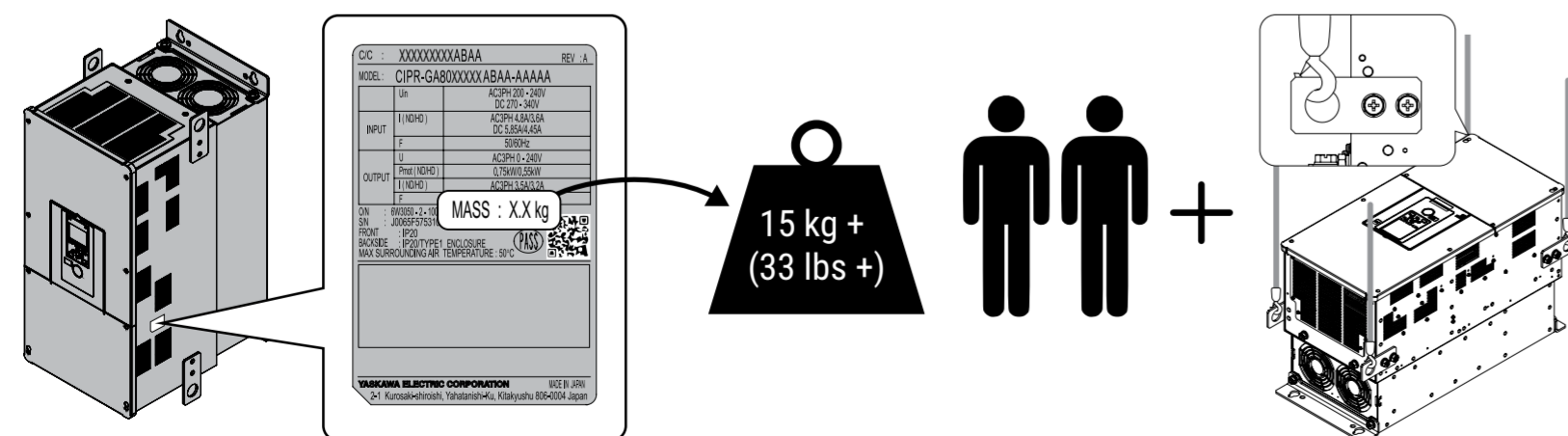

5 Cut a Panel Opening and Install the Drive

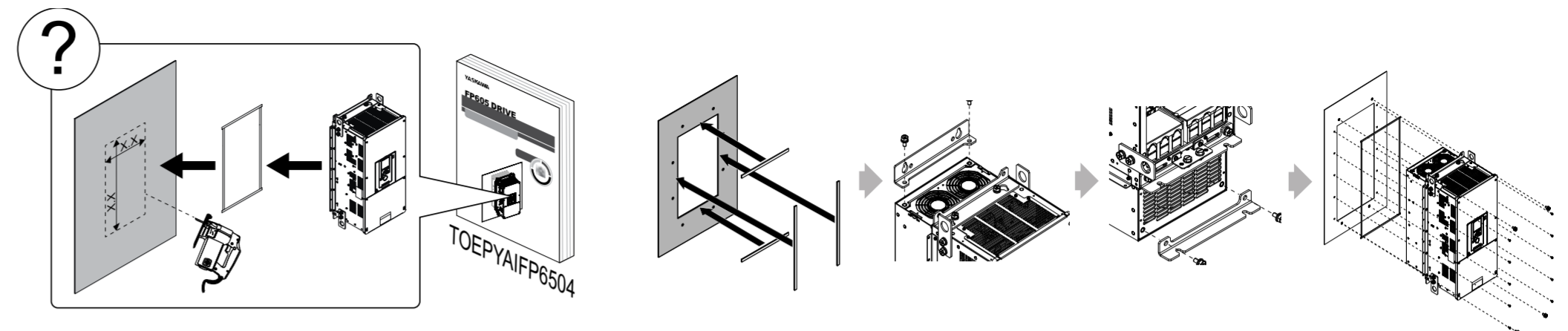

6 Select the Motor and Power Wires, Crimp Terminals, and Branch Circuit Protection

240 V Wires and Crimp Terminals

Drive Model [FP65UXXXX]	Terminal	Wire Range AWG/kcmil (mm ²)* ₁	Recommended Wire Gauge AWG/kcmil	Panduit Crimp Terminal Part Number* _{2,3}	Drive Model [FP65UXXXX]	Terminal	Wire Range AWG/kcmil (mm ²)* ₁	Recommended Wire Gauge AWG/kcmil	Panduit Crimp Terminal Part Number* _{2,3}
2211	R/L1, S/L2, T/L3	3 - 4/0 × 2P (25 - 95 × 2P)	1/0 × 2	LCA1/0-12-X	2343	R/L1, S/L2, T/L3	2/0 - 300 × 2P (70 - 150 × 2P)	4/0 × 2	LCA4/0-12-X
	U/T1, V/T2, W/T3	3 - 4/0 × 2P (25 - 95 × 2P)	1/0 × 2	LCA1/0-12-X		U/T1, V/T2, W/T3	2/0 - 300 × 2P (70 - 150 × 2P)	4/0 × 2	LCA4/0-12-X
	-, +1	2 - 250 × 2P (35 - 120 × 2P)	2/0 × 2	LCA2/0-12-X		-, +1	4/0 - 400 × 2P (95 - 185 × 2P)	250 × 2	LCA250-12-X
	⊕	4 - 350 (25 - 185)	3 or 2	LCA4-12-L/LCA2-12-Q		⊕	1 - 350 (50 - 185)	1/0	LCA1/0-12-X
2273	R/L1, S/L2, T/L3	3 - 4/0 × 2P (25 - 95 × 2P)	2/0 × 2	LCA2/0-12-X	2396	R/L1, S/L2, T/L3	2/0 - 300 × 2P (70 - 150 × 2P)	250 × 2	LCA250-12-X
	U/T1, V/T2, W/T3	3 - 4/0 × 2P (25 - 95 × 2P)	2/0 × 2	LCA2/0-12-X		U/T1, V/T2, W/T3	2/0 - 300 × 2P (70 - 150 × 2P)	250 × 2	LCA250-12-X
	-, +1	2 - 250 × 2P (35 - 120 × 2P)	4/0 × 2	LCA3/0-12-X		-, +1	4/0 - 400 × 2P (95 - 185 × 2P)	350 × 2	LCA350-12-X
	⊕	4 - 350 (25 - 185)	2	LCA2-12-Q		⊕	1 - 350 (50 - 185)	1/0	LCA1/0-12-X

480 V Wires and Crimp Terminals

Drive Model [FP65UXXXX]	Terminal	Wire Range AWG/kcmil (mm ²)* ₁	Recommended Wire Gauge AWG/kcmil	Panduit Crimp Terminal Part Number* _{2,3}	Drive Model [FP65UXXXX]	Terminal	Wire Range AWG/kcmil (mm ²)* ₁	Recommended Wire Gauge AWG/kcmil	Panduit Crimp Terminal Part Number* _{2,3}
4180	R/L1, S/L2, T/L3	3 - 4/0 × 2P (25 - 95 × 2P)	1/0 × 2	LCA1/0-12-X	4477	R/L1, S/L2, T/L3	2/0 - 300 × 4P (70 - 150 × 4P)	3/0 × 4	LCA3/0-12-X
	U/T1, V/T2, W/T3	3 - 4/0 × 2P (25 - 95 × 2P)	1/0 × 2	LCA1/0-12-X		U/T1, V/T2, W/T3	2/0 - 300 × 4P (70 - 150 × 4P)	3/0 × 4	LCA3/0-12-X
	-, +1	2 - 250 × 2P (35 - 120 × 2P)	1/0 × 2	LCA1/0-12-X		-, +1	3/0 - 400 × 4P (95 - 185 × 4P)	4/0 × 4	LCA4/0-12-X
	⊕	4 - 350 (25 - 185)	3 or 2	LCA4-12-L/LCA2-12-Q		⊕	2/0 - 300 (70 - 150)	2/0	LCA2/0-12-X
4240	R/L1, S/L2, T/L3	3 - 4/0 × 2P (25 - 95 × 2P)	1/0 × 2	LCA1/0-12-X	4515	R/L1, S/L2, T/L3	2/0 - 300 × 4P (70 - 150 × 4P)	4/0 × 4	LCA4/0-12-X
	U/T1, V/T2, W/T3	3 - 4/0 × 2P (25 - 95 × 2P)	1/0 × 2	LCA1/0-12-X		U/T1, V/T2, W/T3	2/0 - 300 × 4P (70 - 150 × 4P)	4/0 × 4	LCA4/0-12-X
	-, +1	2 - 250 × 2P (35 - 120 × 2P)	3/0 × 2	LCA3/0-12-X		-, +1	3/0 - 400 × 4P (95 - 185 × 4P)	250 × 2	LCA250-12-X
	⊕	4 - 350 (25 - 185)	2	LCA2-12-Q		⊕	2/0 - 300 (70 - 150)	2/0	LCA2/0-12-X
4302	R/L1, S/L2, T/L3	3 - 4/0 × 2P (25 - 95 × 2P)	3/0 × 2	LCA3/0-12-X	4590	R/L1, S/L2, T/L3	2/0 - 300 × 4P (70 - 150 × 4P)	4/0 × 4	LCA4/0-12-X
	U/T1, V/T2, W/T3	3 - 4/0 × 2P (25 - 95 × 2P)	3/0 × 2	LCA3/0-12-X		U/T1, V/T2, W/T3	2/0 - 300 × 4P (70 - 150 × 4P)	250 × 4	LCA250-12-X
	-, +1	2 - 250 × 2P (35 - 120 × 2P)	4/0 × 2	LCA4/0-12-X		-, +1	3/0 - 400 × 4P (95 - 185 × 4P)	300 × 4	LCA300-12-X
	⊕	1 - 350 (50 - 185)	1/0	LCA1/0-12-X		⊕	2/0 - 300 (70 - 150)	3/0	LCA3/0-12-X
4361	R/L1, S/L2, T/L3	2/0 - 300 × 2P (70 - 150 × 2P)	4/0 × 2	LCA4/0-12-X	4720	R/L1, S/L2, T/L3	2/0 - 300 × 4P (70 - 150 × 4P)	300 × 4	LCA300-12-X
	U/T1, V/T2, W/T3	2/0 - 300 × 2P (70 - 150 × 2P)	4/0 × 2	LCA4/0-12-X		U/T1, V/T2, W/T3	2/0 - 300 × 4P (70 - 150 × 4P)	300 × 4	LCA300-12-X
	-, +1	4/0 - 400 × 2P (95 - 185 × 2P)	300 × 2	LCA300-12-X		-, +1	3/0 - 400 × 4P (95 - 185 × 4P)	400 × 4	LCA400-12-6
	⊕	1 - 350 (50 - 185)	1/0	LCA1/0-12-X		⊕	2/0 - 300 (70 - 150)	4/0	LCA4/0-12-X
4414	R/L1, S/L2, T/L3	2/0 - 300 × 2P (70 - 150 × 2P)	250 × 2	LCA250-12-X	4720	R/L1, S/L2, T/L3	2/0 - 300 × 4P (70 - 150 × 4P)	300 × 4	LCA300-12-X
	U/T1, V/T2, W/T3	2/0 - 300 × 2P (70 - 150 × 2P)	300 × 2	LCA300-12-X		U/T1, V/T2, W/T3	2/0 - 300 × 4P (70 - 150 × 4P)	300 × 4	LCA300-12-X
	-, +1	4/0 - 400 × 2P (95 - 185 × 2P)	350 × 2	LCA350-12-X		-, +1	3/0 - 400 × 4P (95 - 185 × 4P)	400 × 4	LCA400-12-6
	⊕	1 - 350 (50 - 185)	1/0	LCA1/0-12-X		⊕	2/0 - 300 (70 - 150)	4/0	LCA4/0-12-X

*1 The metric wire gauge values are provided as reference information from equivalent AWG sizes and not exactly the same sizes as the AWG/kcmil values. Obey local safety regulations for wire sizes and make sure that the ferrule or crimp terminals are correct for your size.
 *2 For use with Panduit Corp. heat-shrinkable tubing HSTT series or an equivalent UL-recognized heat shrinkable tubing rated 600 V minimum.
 *3 Refer to the Installation & Primary Operation (TOEPC7106171F) for possible Panduit Type P and Type S crimp terminal alternatives.

Required Short Circuit Protection

Install one of the types of short circuit protection devices listed here to comply with UL 508C. Semiconductor protective type fuses are recommended, but the tables also show alternative short circuit protection devices.

Required Short Circuit Protection for FP605 AC Drives (Three-Phase 240 V)

		2211	2273	2343	2396	
Drive Mounted without Supplemental Enclosure (Using Type 1 Kit)	Eaton/Bussmann Semiconductor Fuse ¹ Part Number (Permitted Only in Type 1 Kit)	Not allowed. Does not support internal fuses for these drive models.				
	Class CC, J, or T Fuse ² Maximum Amps	350	450	600	700	
Drive Mounted in Supplemental Enclosure	Any Size Protected Enclosure (Ventilated or Non-Ventilated)	Eaton/Bussmann Semiconductor Fuse ¹ Part Number	FWH-600A	FWH-800A	FWH-1000A or FWH-1000B	FWH-1000A or FWH-1000B
		Class CC, J, or T Fuse ² Maximum Amps	350	450	600	700
	Restricted Size Protected Enclosure (Ventilated Only)	Class CC, J, or T Fuse ² Maximum Amps	Enclosure volume not restricted. Refer to the values in the row above for fuses.			
		MCCB ³ Maximum Amps	500	600	700	800
		Schneider MCP ³ Part Number	LAL3640036M or LLL36400M37X	LAL3640036M or LLL36400M37X	PLL34060M68	PLL34060M68
Enclosure Volume Minimum (in ³)	External Heatsink	52800	52800	52800	52800	
	Internal Heatsink	14657	14657	52800	52800	

*1 Protection device must be in same enclosure with drive.
 *2 Class T fuses are fast-acting (non-time-delay) only. Class CC and J can be either time-delay or non-time-delay.
 *3 Protection device and drive permitted in same or separate enclosure.

Required Short Circuit Protection for FP605 AC Drives (Three-Phase 480 V)

		4180	4240	4302	4361	4414	4477	4515	4590	4720		
Drive Mounted without Supplemental Enclosure (Using Type 1 Kit)	Eaton/Bussmann Semiconductor Fuse ¹ Part Number (Permitted Only in Type 1 Kit)	Not allowed. Does not support internal fuses for these drive models.				FWH-800A	FWH-1000A or FWH-1000B	FWH-1200A or FWH-1200B	FWH-1200A or FWH-1200B	FWH-1400A	FWH-1400A	
	Class CC, J, or T Fuse ² Maximum Amps	300	400	500	Not allowed. Must use semiconductor fuses.							
Drive Mounted in Supplemental Enclosure	Any Size Protected Enclosure (Ventilated or Non-Ventilated)	Eaton/Bussmann Semiconductor Fuse ¹ Part Number	FWH-500A	FWH-600A	FWH-700A	FWH-800A	FWH-1000A or FWH-1000B	FWH-1200A or FWH-1200B	FWH-1200A or FWH-1200B	FWH-1400A	FWH-1400A	
		Class CC, J, or T Fuse ² Maximum Amps	300	400	500	Not allowed. Must use minimum enclosure volume requirements.						
	Restricted Size Protected Enclosure (Ventilated Only)	Class CC, J, or T Fuse ² Maximum Amps	Enclosure volume not restricted. Refer to the values in the row above for fuses.				600	700	800	900	1000	1200
		MCCB ³ Maximum Amps	450	600	700	700	800	900	1000	1200	1400	
		Schneider MCP ³ Part Number	JLL36250M75	LAL3640036M or LLL36400M37X	LAL3640036M or LLL36400M37X	PLL34060M68	PLL34060M68	PLL34080M68	PLL34080M68	PLL34080M68	PLL34100M69	
Enclosure Volume Minimum (in ³)	External Heatsink	52800 ⁴	52800 ⁴	52800 ⁴	52800 ⁴	52800 ⁴	52800 ⁴	52800 ⁴	52800 ⁴	52800 ⁴		
	Internal Heatsink	14657	14657	14657	52800	52800	52800	52800	52800	52800		

*1 Protection device must be in same enclosure with drive.
 *2 Class T fuses are fast-acting (non-time-delay) only. Class CC and J can be either time-delay or non-time-delay.
 *3 Protection device and drive permitted in same or separate enclosure.
 *4 External heatsink installation on these models requires a heatsink shroud and filter.

7 Remove the Terminal Cover

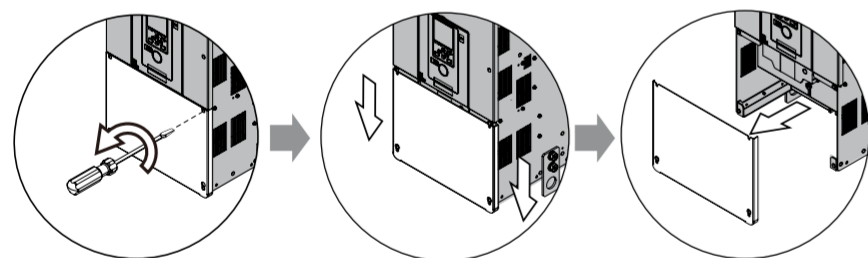

8 Remove the Terminal Block Cover and Wiring Cover

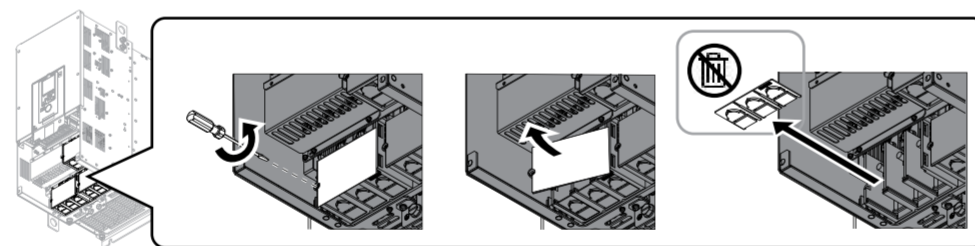

9 Remove Terminal Block Nut to Attach Crimp Terminals

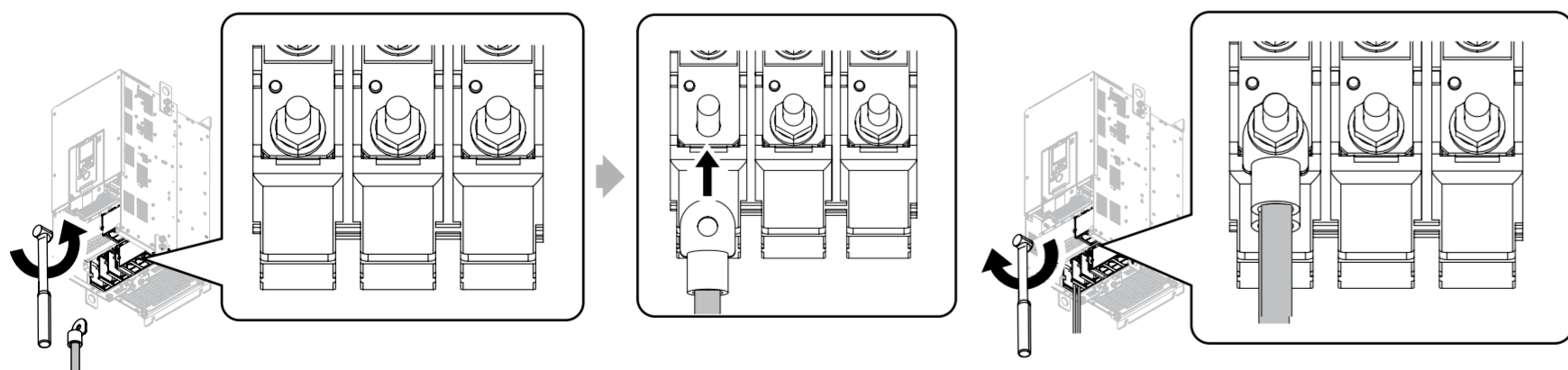

10 Install the Motor Wiring and Power Wiring

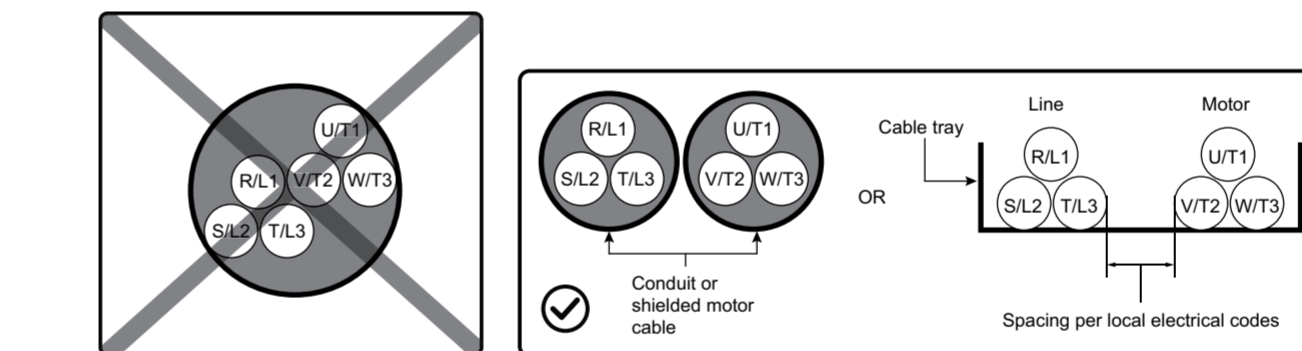
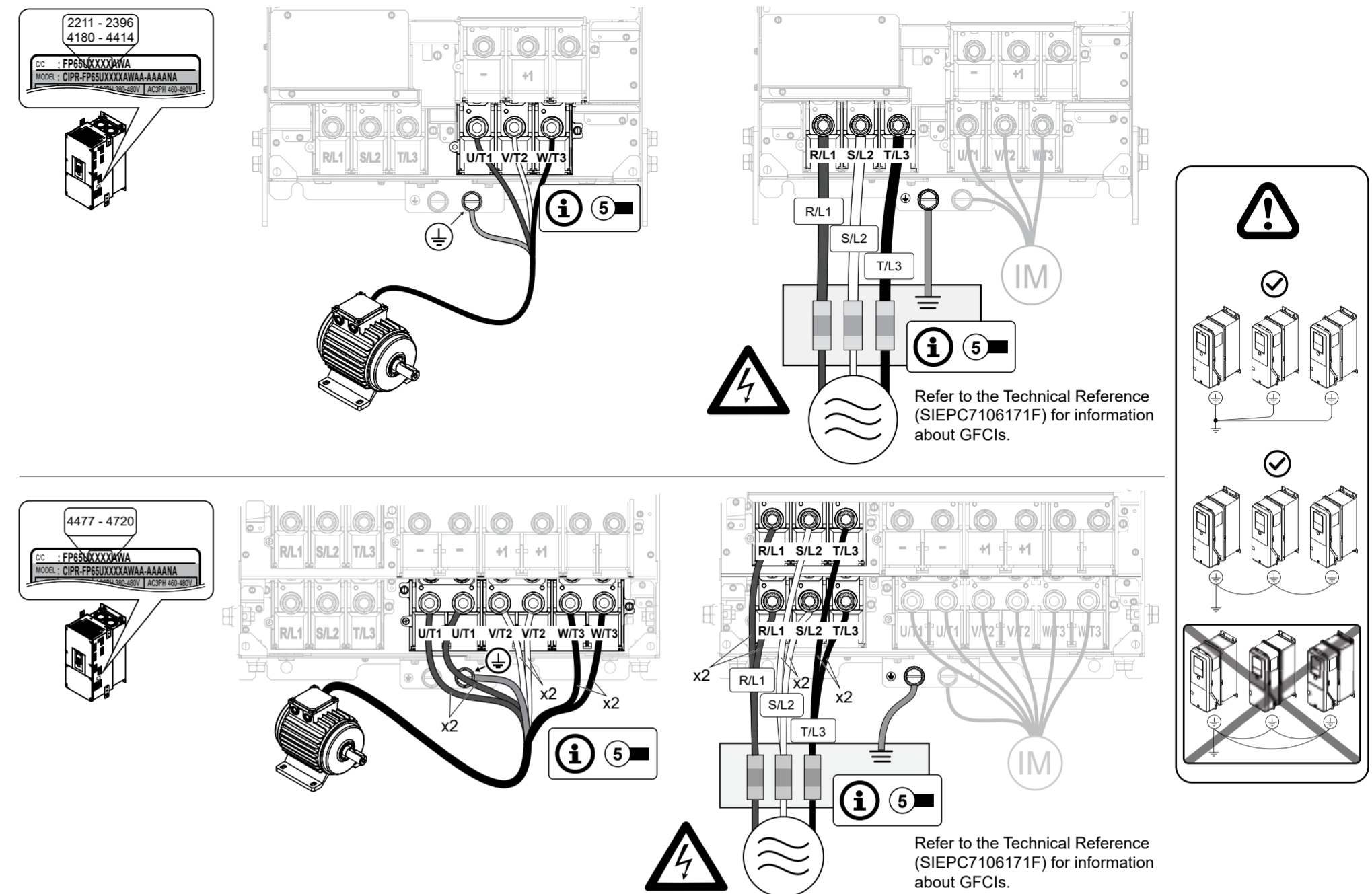

11 Remove the Tabs and Install the Wiring Cover, Terminal Block Cover, and Terminal Cover

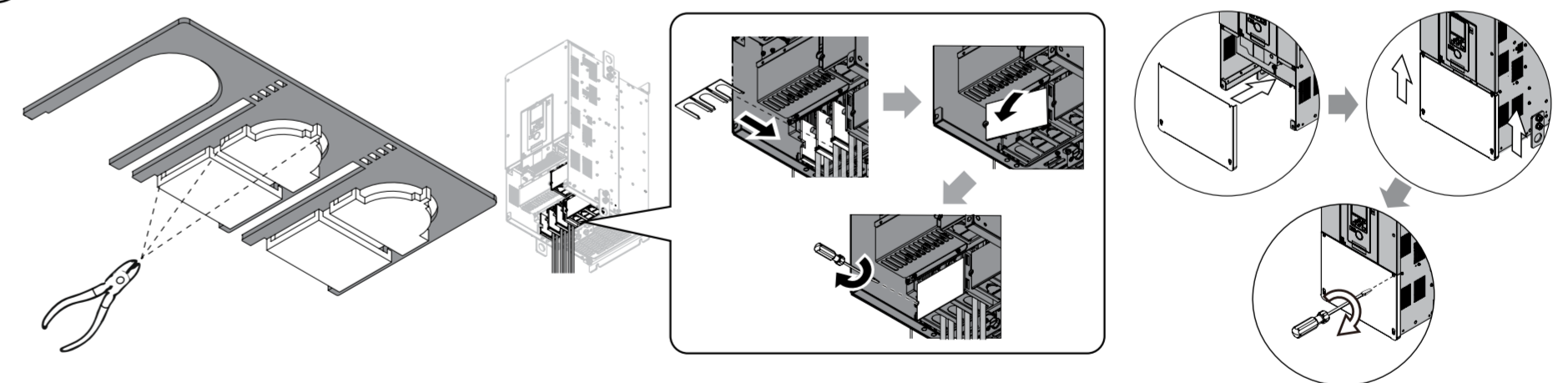

12 Energize the Drive and Confirm It Is Ready

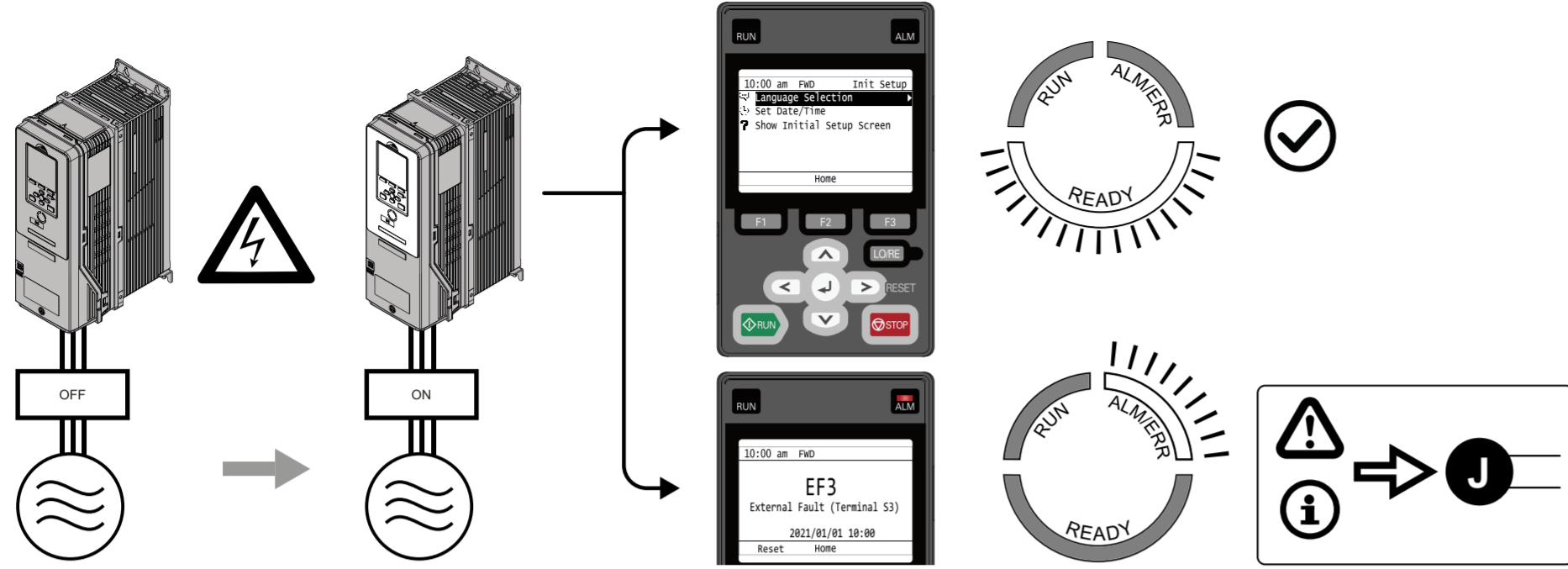

13 Set the Motor Rated Current (FLA) from the Motor Nameplate in E2-01

3 PHASE INVERTER DUTY AC INDUCTION MOTOR NAMEPLATE EXAMPLE											
MODEL	XX	123AAA123XX-X0		X	FRAME 123AX						
POLES	X	ENC XXX	CODEX								
VOLTS	XXX	FL RPM	XXXX								
SF	1.0	DUTY CONT	MAX AMB °C	XX							
SERIAL		N.L. AMPS	XX.XX.X								
MAX RPM	4200	S.E. BRG. 309	O.S.E. BRG.	XXX	ROTOR WK	X.X					
Hz	kW	RPM	TORQUE (LB FT)	VOLTS (HIGH CONN)	AMPS (HIGH CONN)						
1	-	0	XX.X	-	XX.X						
60	XX	XXXX	XX.X	XXX	XX.X						
120	XX	XXXX	XX.X	XXX	XX.X						
OHMS PH.	R1: XXX	R2: XXX	X1: X.XX	X2: X.XX	XM: XX.X						
P/N XXXXXXXX											

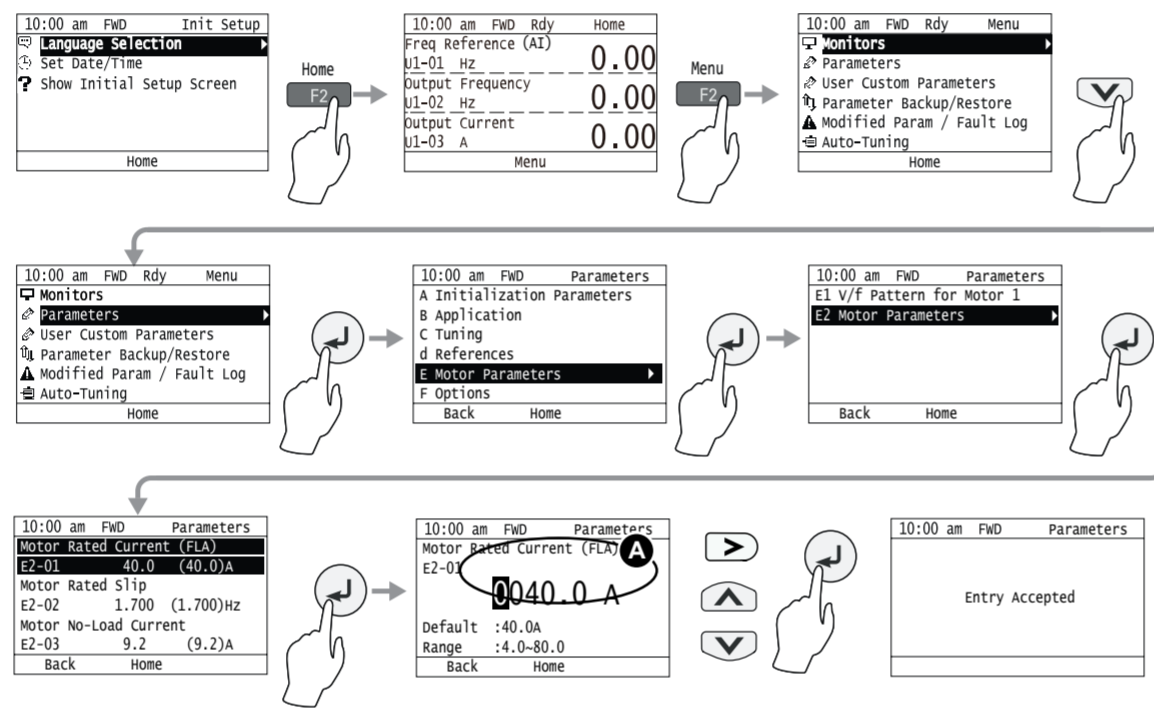

14 Set Parameter L8-35 = 2 (Installation Method Selection)

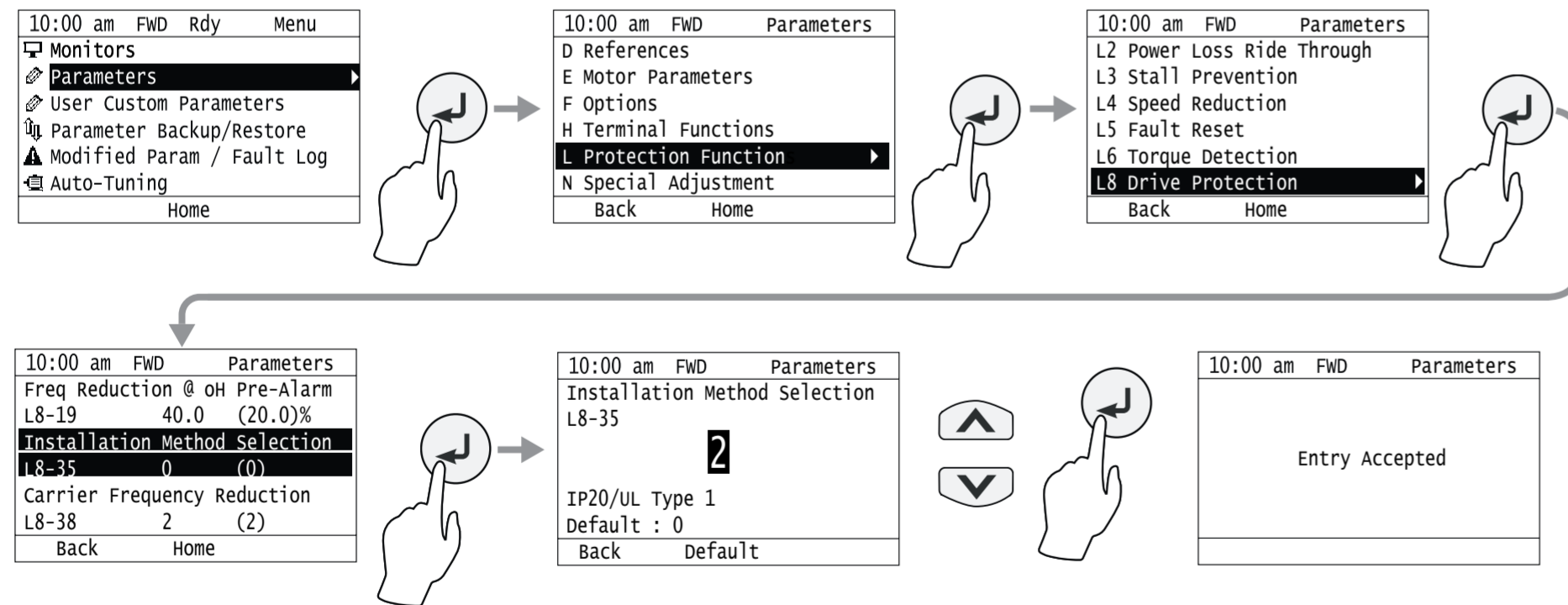

14 Set the Drive for LOCAL Control and Check the Motor Rotation Direction

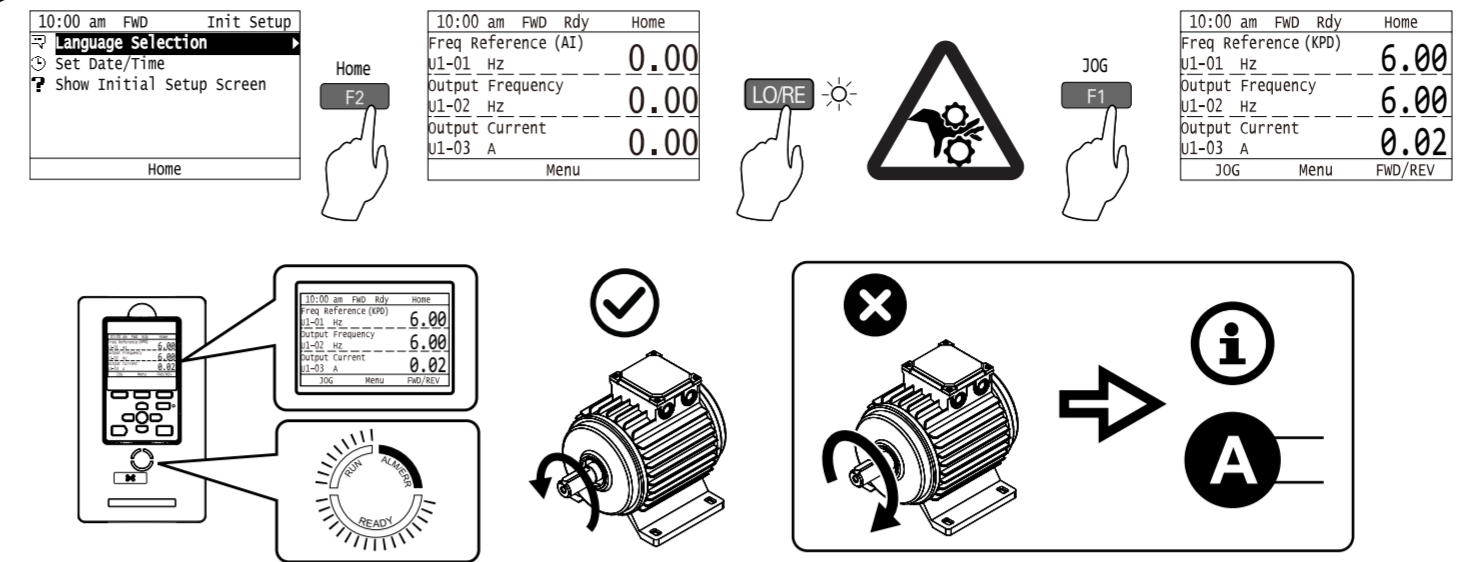

Additional Information for Installation and Primary Operation

A If the Motor Does Not Rotate in the Correct Direction

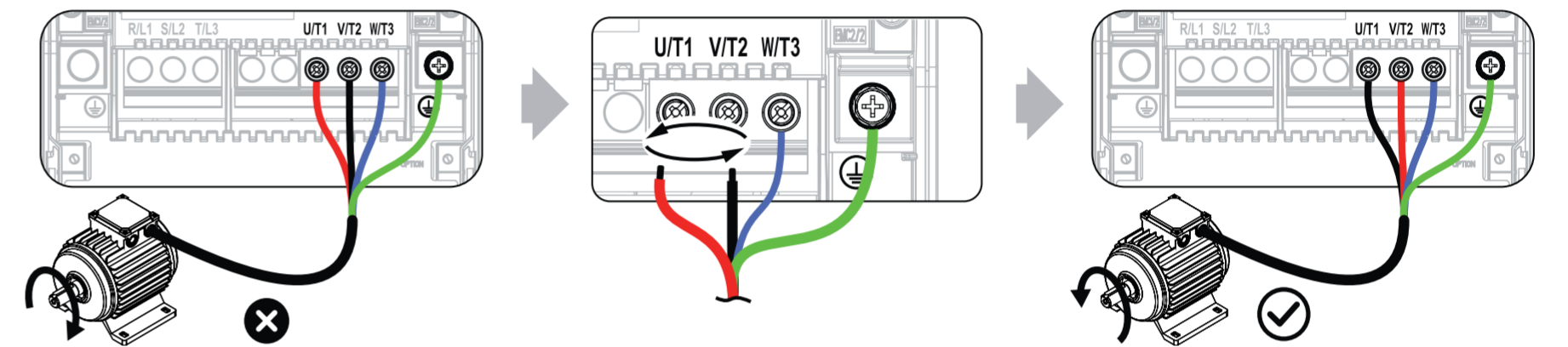

B To Install a DeviceNet Communication Option Card (SI-N3), Remove the Faceplate Cut Away Section

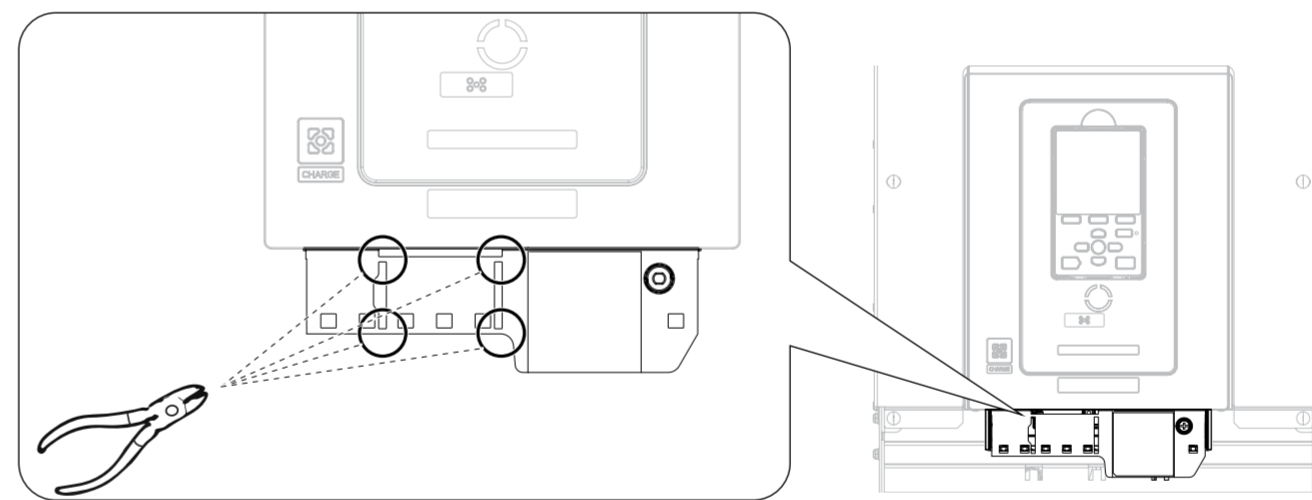

C Control Circuit Configuration

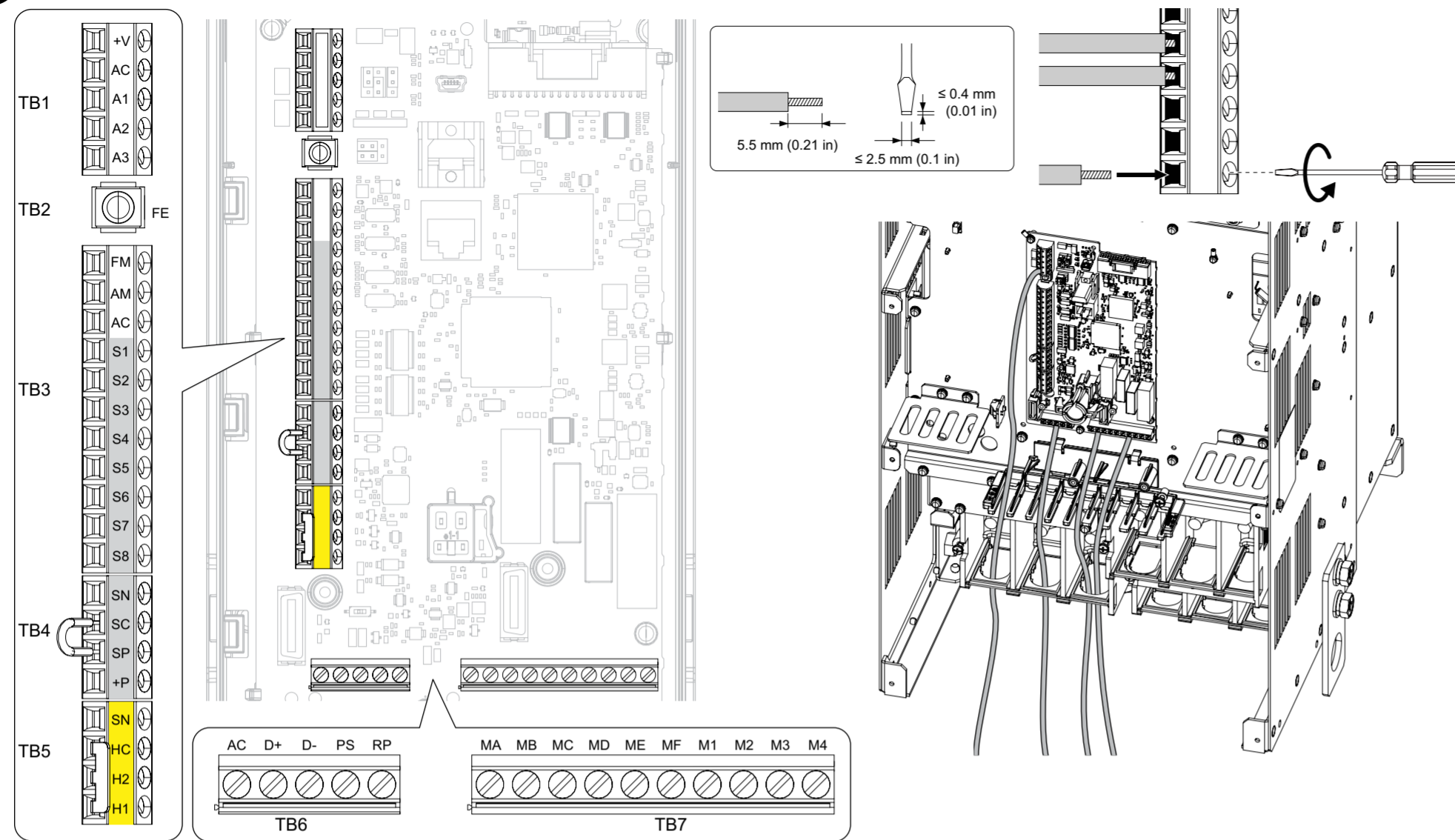

D Switches and Jumpers on the Control Board

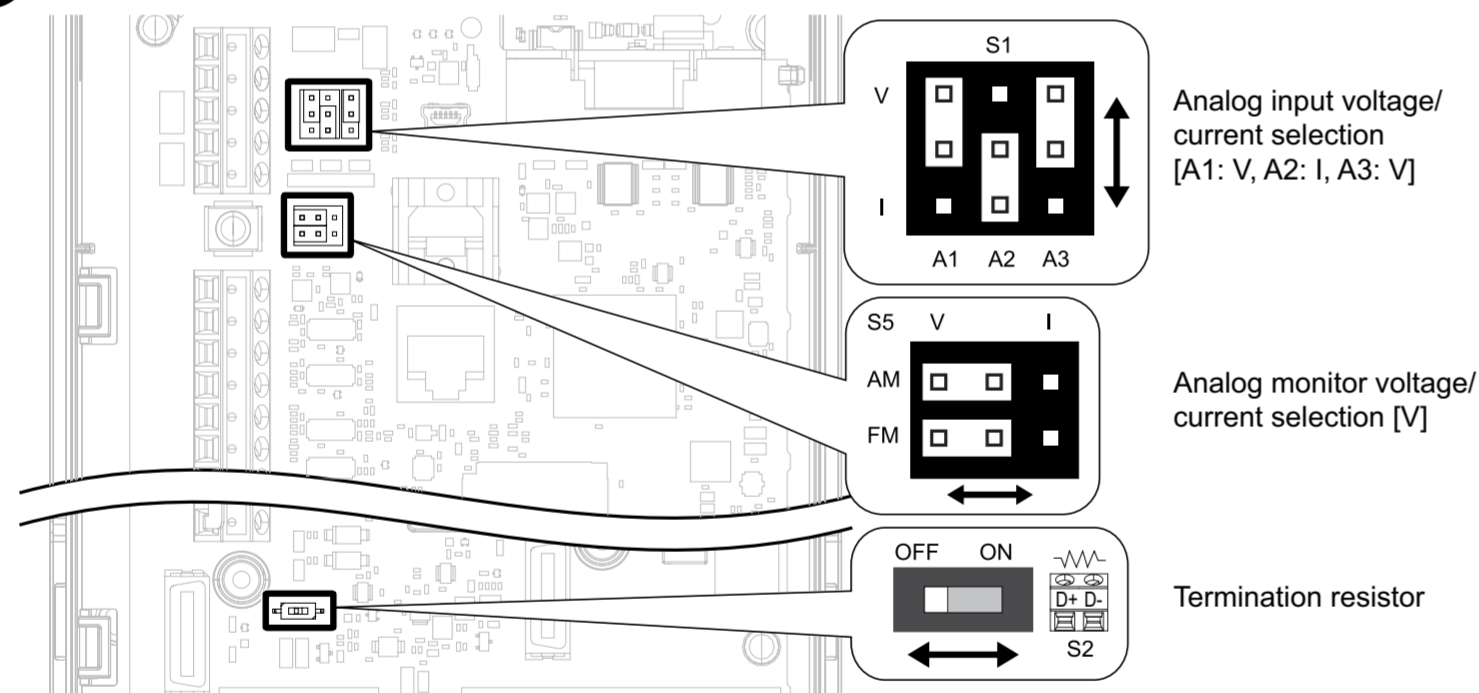

E Connection Diagram and Terminal Functions

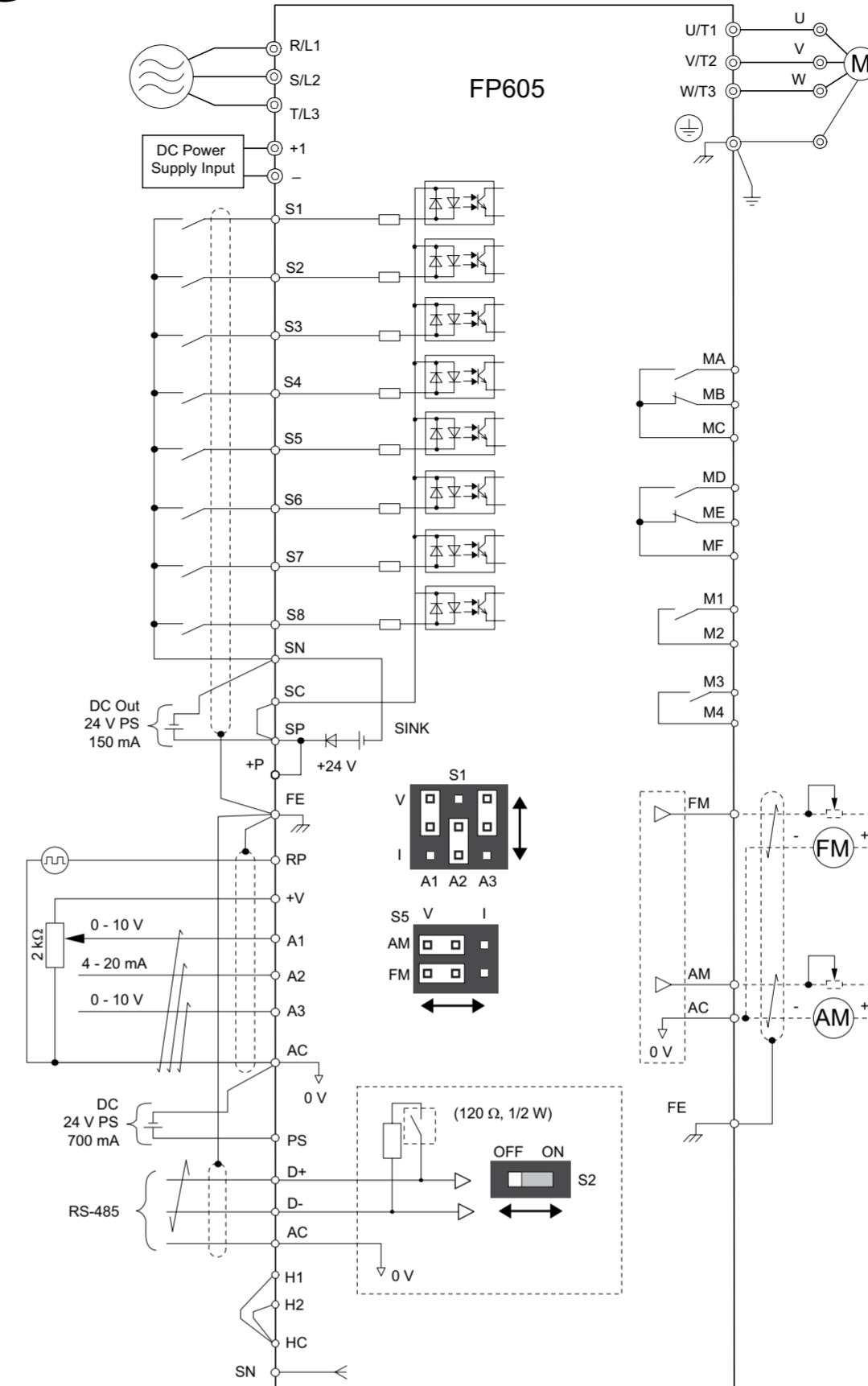

Terminal	Type	Signal Level	Default
S1	MFDI 1	Photocoupler 24 V, 6 mA Internal impedance: 4.7 kΩ	Forward RUN (2-Wire)
S2	MFDI 2		Reverse RUN (2-Wire)
S3	MFDI 3		External Fault (NO-Always-Coast)
S4	MFDI 4		Fault Reset
S5	MFDI 5		Multi-Step Speed Reference 1
S6	MFDI 6		Multi-Step Speed Reference 2
S7	MFDI 7		Jog Reference Selection
S8	MFDI 8		Baseblock Command (N.O.)
SN	MFDI power 0 V		-
SC	MFDI common	24 V, 150 mA maximum	-
SP	MFDI power +24 VDC		-
H1	Safe disable input 1	Photocoupler 24 V, 6 mA Internal impedance: 4.7 kΩ	-
H2	Safe disable input 2		-
HC	Safe disable common		-
RP	Multi-function pulse train input	<ul style="list-style-type: none"> Response frequency: 0 Hz ~ 32 Hz H level duty: 30% ~ 70% H level voltage: 3.5 V ~ 13.2 V L level voltage: 0.0 V ~ 0.8 V Input impedance: 3 kΩ 	-
+V	Frequency setting power supply	10.5 V (20 mA maximum)	-
A1	MFAI 1	0 V ~ 10 V/100% (input impedance 20 kΩ)	Master frequency reference
A2	MFAI 2	4 mA ~ 20 mA/100%	Combined w/A1
A3	MFAI 3	0 mA ~ 20 mA/100% (input impedance 250 Ω)	Auxiliary frequency reference 1
AC	Common	0 V	-
FE	Connect shielded cable	-	-
MA	Fault relay out	30 VDC, 10 mA ~ 2 A 250 VAC, 10 mA ~ 2 A Minimum load: 5 V, 10 mA	Fault
MB	Fault relay out	30 VDC, 10 mA ~ 2 A 250 VAC, 10 mA ~ 2 A Minimum load: 5 V, 10 mA	Fault
MC	Common		-
MD	MFDO	30 VDC, 10 mA ~ 2 A 250 VAC, 10 mA ~ 2 A Minimum load: 5 V, 10 mA	Speed agree 1
ME	MFDO	30 VDC, 10 mA ~ 2 A 250 VAC, 10 mA ~ 2 A Minimum load: 5 V, 10 mA	Zero speed
MF	Common		-
M1	MFDO	30 VDC, 10 mA ~ 2 A 250 VAC, 10 mA ~ 2 A Minimum load: 5 V, 10 mA	During run
M2	MFDO	30 VDC, 10 mA ~ 2 A 250 VAC, 10 mA ~ 2 A Minimum load: 5 V, 10 mA	Zero speed
M3	MFDO	30 VDC, 10 mA ~ 2 A 250 VAC, 10 mA ~ 2 A Minimum load: 5 V, 10 mA	Zero speed
M4	MFDO	30 VDC, 10 mA ~ 2 A 250 VAC, 10 mA ~ 2 A Minimum load: 5 V, 10 mA	Zero speed
FM	MFAO 1	0 V ~ +10 V/0% ~ 100% 4 mA ~ 20 mA	Output frequency
AM	MFAO 2	0 V ~ +10 V/0% ~ 100% 4 mA ~ 20 mA	Output current
AC	Common	0 V	-
+P	External power supply	24 V (150 mA maximum)	-
PS	External 24 V PS input	21.6 VDC ~ 26.4 VDC, 700 mA	-
AC	External 24 V PS ground	0V	-
D+	Communication +	MEMOBUS/Modbus	-
D-	Communication -	115.2 kbps maximum	-
AC	Common	0 V	-

F Set Frequency Reference Source

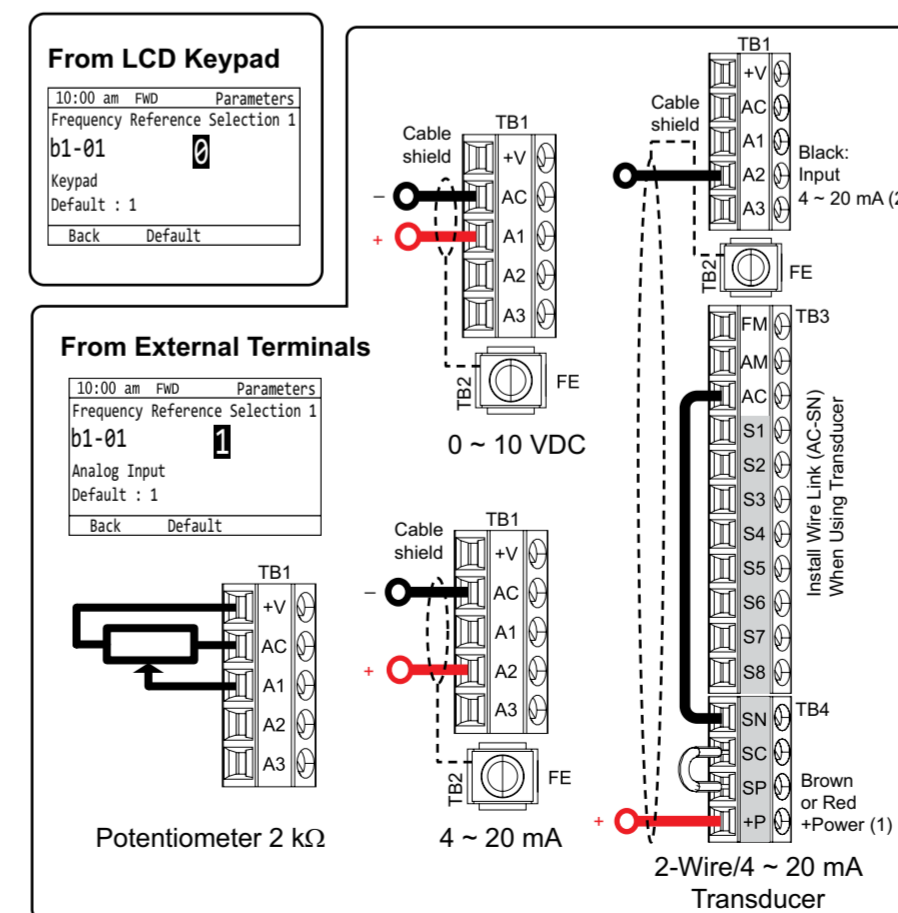

G Set Start/Stop Control Method from External Terminals

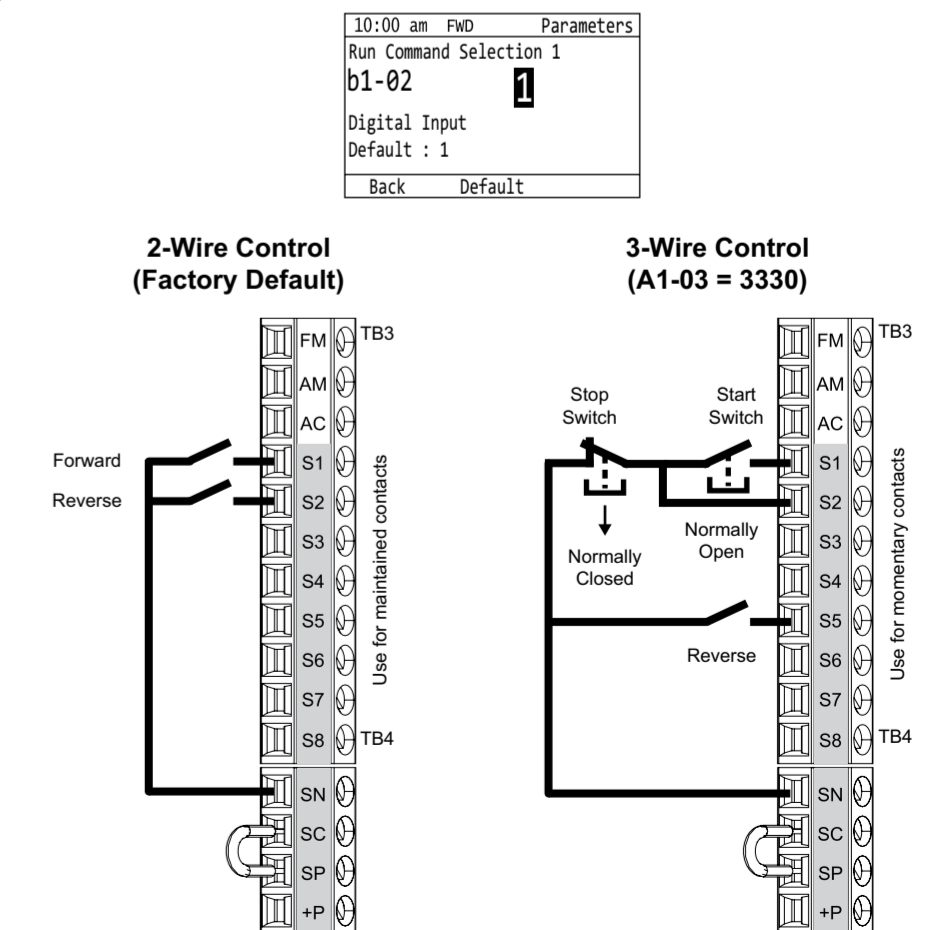

H

If You Push the RUN Button but the Motor Does Not Spin

10:00 am FWD Rdy Home
Freq Reference (KPD) 0.00
U1-01 Hz
Output Frequency 0.00
U1-02 Hz
Output Current 0.00
U1-03 A
JOG Menu FWD/REV

10:00 am FWD Init Setup
Language Selection
Set Date/Time
Show Initial Setup Screen
Home

10:00 am FWD Rdy Home
Freq Reference (AI) 0.00
U1-01 Hz
Output Frequency 0.00
U1-02 Hz
Output Current 0.00
U1-03 A
Menu

10:00 am FWD Parameters
Reference 1
d1-01 000.00 Hz
Default : 0.00 Hz
Range : 0.00-60.00
Back Default Min/Max

10:00 am FWD Parameters
Reference 1
d1-01 010.00 Hz
Default : 0.00 Hz
Range : 0.00-60.00
Back Default Min/Max

10:00 am FWD Parameters
Entry Accepted

10:00 am FWD Rdy Home
Freq Reference (KPD) 10.00
U1-01 Hz
Output Frequency 0.00
U1-02 Hz
Output Current 0.00
U1-03 A
JOG Menu FWD/REV

10 Hz

I

Parameter Groups

A: Initialization	d: Reference Settings	H: Terminal Functions	n: Special Adjustment	Y: Application Features
A1 Initialization	d1 Frequency Reference	H1 Digital Inputs	n1 Hunting Prevention	Y1 Application Basics
A2 User Parameters	d2 Reference Limits	H2 Digital Outputs	n3 High Slip/Overexcite Braking	Y2 PID Sleep and Protection
b: Application	d3 Jump Frequency	H3 Analog Inputs	n7 EZ Drive	Y3 Contactor Multiplex
b1 Operation Mode Selection	d4 Freq. Ref. Up/Down & Hold	H4 Analog Outputs	n8 PM Motor Control Tuning	Y4 Application Advanced
b2 DC Injection Braking and Short Circuit Braking	d6 Field Weakening	H5 Modbus Communication	o: Keypad-Related Settings	Y8 De-Scale/De-Rag
b3 Speed Search	d7 Offset Frequency	H6 Pulse Train Input	o1 Keypad Display	YA Preset Setpoint
b4 Timer Function	E: Motor	H7 Virtual Inputs/Outputs	o2 Keypad Operation	YC Feedback Features
b5 PID Control	E1 V/f Pattern for Motor 1	L: Protection Functions	o3 Copy Keypad Function	YF PI Auxiliary Control
b6 Dwell Function	E2 Motor Parameters	L1 Motor Protection	o4 Maintenance Monitors	
b8 Energy Saving	E3 V/f Pattern for Motor 2	L2 Power Loss Ride Through	o5 Log Function	
C: Tuning	E4 Motor 2 Parameters	L3 Stall Prevention	S: Special Applications	
C1 Accel & Decel Time	E5 PM Motor Settings	L4 Speed Detection	S1 Dynamic Noise Control	
C2 S-Curve Characteristics	E9 Motor Setting	L5 Fault Restart	S3 PI2 Control	
C3 Slip Compensation	F: Options	L6 Torque Detection	S6 Protection	
C4 Torque Compensation	F2 Analog Input Option	L7 Torque Limit	T: Auto-Tuning	
C5 Auto Speed Regulator (ASR)	F3 Digital Input Option	L8 Drive Protection	T1 InductionMotor Auto-Tuning	
C6 Carrier Frequency	F4 Analog Output Option	L9 Drive Protection 2	T2 PM Motor Auto-Tuning	
	F5 Digital Output Option		T4 EZ Tuning	
	F6 Communication Options			
	F7 Ethernet Options			

Frequently Used Parameters

Parameter Number Name	Default Description	Parameter Number Name	Default Description	Parameter Number Name	Default Description
A1-06 Application Preset	0 No preset	b5-03 Integral Time (I)	1.0 s	d2-02 Frequency Reference Lower Limit	0.0%
b1-01 Frequency Reference Selection 1	1 Analog Input	b5-05 Derivative Time (D)	0.00 s	E1-01 Input AC Supply Voltage	-
b1-02 Run Command Selection 1	1 Digital Input	C1-01 Acceleration Time 1	10.0 s	E2-01 Motor Rated Current (FLA)	-
b1-03 Stopping Method Selection	1 Coast to Stop	C1-02 Deceleration Time 1	10.0 s	H3-09 Terminal A2 Signal Level Select	2 4 to 20 mA
b5-01 PID Mode Setting	0 Disabled	d2-01 Frequency Reference Upper Limit	100.0%	H3-10 Terminal A2 Function Selection	0 Frequency Reference
b5-02 Proportional Gain (P)	1.00				

J

Troubleshooting Resources for Drive Faults and Alarms

Resource	Choose This When:	URL	QR Code
Installation & Primary Operation	You have access to the paper copy of manuals packaged with the drive. This manual lists all drive faults and alarms, and offers a selection of causes and solutions.	https://www.yaskawa.com/toeocp7106171f	 PDF download
IP55/UL Type 12 Heatsink External Mounting		https://www.yaskawa.com/toeypaifp6504	 PDF download
DriveWizard Mobile App	You want to use your smartphone or tablet and use the embedded help to look up the full complement of causes and solutions to all drive faults and alarms.	 https://www.yaskawa.com/dwm	 App download
Maintenance & Troubleshooting Manual	You want to download a PDF of the manual to your smartphone or tablet. This manual lists the full complement of causes and solutions to all drive faults and alarms and also includes detailed information about drive maintenance, wiring, and programming.	 https://www.yaskawa.com/toeypaifp6501	 PDF download

K

Additional Resources



Mobile App



DriveWizard® Mobile Commissioning Smartphone App
<https://www.yaskawa.com/dwm>

Product Manuals



•PDFs
•Online HTML5-Searchable
•Manuals App
<https://www.yaskawa.com/tp605manuals>

DriveWizard is a registered trademark of Yaskawa America, Inc. and is registered in the U.S. Patent and Trademark Office.

L

Customer Feedback

Comments or questions about this document? Fill out our online form:



or
Email us: technical_documentation@yaskawa.com
Call us: 1-800-YASKAWA (927-5292)
www.yaskawa.com/DRV-F-0006

Please consider following us on social media:

www.youtube.com/yaskawayea

www.linkedin.com/company/18822

www.twitter.com/yaskawa

Headquarters Address:

YASKAWA AMERICA, INC.
2121 Norman Drive South
Waukegan, IL 60085
USA
© 2022 YASKAWA America, Inc.
MANUAL NO. TOEPYAIFP6503 <0>->0
Published in USA August 2022