

## iQpump Micro AC Drive Compact Intelligent Pump Controller User Manual

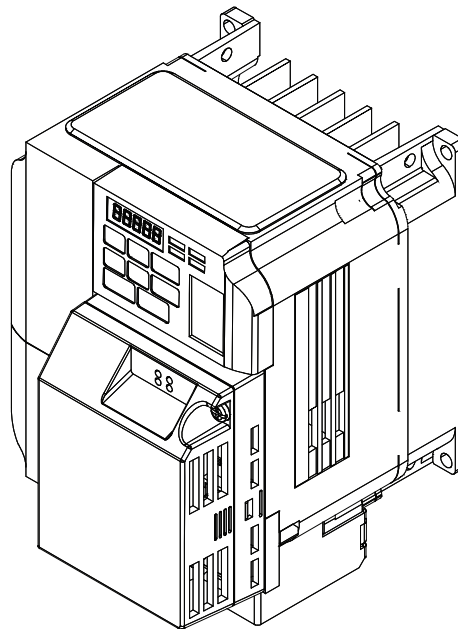
Type: CIMR-PW

Models: 200 V Class, Single-Phase Input: 1 to 5 HP ND

200 V Class, Three-Phase Input: 1.5 to 25 HP ND

400 V Class, Three-Phase Input: 1 to 25 HP ND

To properly use the product, read this manual thoroughly and retain for easy reference, inspection, and maintenance. Ensure the end user receives this manual.



Receiving **1**

Mechanical Installation **2**

Electrical Installation **3**

Start-Up Programming & Operation **4**

Parameter Details **5**

Troubleshooting **6**

Periodic Inspection & Maintenance **7**

Specifications **A**

Parameter List **B**

MEMOBUS/Modbus Communications **C**

Standards Compliance **D**

Copyright © 2014 YASKAWA AMERICA, INC. All rights reserved.

No part of this publication may be reproduced, stored in a retrieval system, or transmitted, in any form or by any means, mechanical, electronic, photocopying, recording, or otherwise, without the prior written permission of Yaskawa. No patent liability is assumed with respect to the use of the information contained herein. Moreover, because Yaskawa is constantly striving to improve its high-quality products, the information contained in this manual is subject to change without notice. Every precaution has been taken in the preparation of this manual. Yaskawa assumes no responsibility for errors or omissions. Neither is any liability assumed for damages resulting from the use of the information contained in this publication.

# Table of Contents

|   |           |
|---|-----------|
| <b>i. PREFACE &amp; GENERAL SAFETY</b> .....                                    | <b>11</b> |
| <b>i.1 Preface</b> .....  | <b>12</b> |
| Applicable Documentation.....   | 12        |
| Symbols.....  | 12        |
| Terms and Abbreviations .....   | 12        |
| Trademarks .....  | 12        |
| <b>i.2 General Safety</b> .....   | <b>13</b> |
| Supplemental Safety Information .....   | 13        |
| Safety Messages.....  | 14        |
| General Application Precautions .....   | 15        |
| Motor Application Precautions.....  | 17        |
| Drive Label Warning Example.....  | 19        |
| Warranty Information.....   | 19        |
| <b>1. RECEIVING</b> .....   | <b>21</b> |
| <b>1.1 Section Safety</b> .....   | <b>22</b> |
| <b>1.2 Model Number and Nameplate Check</b> .....                               | <b>23</b> |
| Nameplate .....   | 23        |
| <b>2. MECHANICAL INSTALLATION</b> .....   | <b>25</b> |
| <b>2.1 Section Safety</b> .....   | <b>26</b> |
| <b>2.2 Mechanical Installation</b> .....  | <b>28</b> |
| Installation Environment.....   | 28        |
| Installation Orientation and Spacing.....                                       | 28        |
| Exterior and Mounting Dimensions .....  | 30        |
| <b>3. ELECTRICAL INSTALLATION</b> .....   | <b>37</b> |
| <b>3.1 Section Safety</b> .....   | <b>38</b> |
| <b>3.2 Standard Connection Diagram</b> .....                                    | <b>40</b> |
| Transducer Connection Diagrams.....   | 43        |
| <b>3.3 Terminal Block Configuration</b> .....                                   | <b>44</b> |
| <b>3.4 Protective Covers</b> .....  | <b>45</b> |
| IP20/NEMA 1, UL Type 1 Front and Bottom Cover Removal and Installation .....    | 45        |
| IP20/NEMA 1, UL Type 1 Top Cover Removal and Installation.....                  | 46        |
| <b>3.5 Preparing IP66/NEMA 4X, UL Type 4X Enclosure Drives for Wiring</b> ..... | <b>47</b> |
| Select Cable Gland .....  | 47        |
| IP66/NEMA 4X, UL Type 4X Enclosure Front Cover Removal and Installation.....    | 48        |

|             |  |            |
|-------------|--|------------|
| <b>3.6</b>  | <b>Main Circuit Wiring</b> .....                           | <b>50</b>  |
|             | Main Circuit Terminal Functions.....                       | 50         |
|             | Wire Gauges and Tightening Torques .....                   | 50         |
|             | Main Circuit Terminal Power Supply and Motor Wiring.....   | 53         |
| <b>3.7</b>  | <b>Control Circuit Wiring</b> .....                        | <b>55</b>  |
|             | Control Circuit Terminal Block Functions .....             | 55         |
|             | Terminal Configuration .....                               | 56         |
|             | Wiring the Control Circuit Terminal .....                  | 57         |
| <b>3.8</b>  | <b>I/O Connections</b> .....                               | <b>59</b>  |
|             | Sinking/Sourcing Mode Switch.....                          | 59         |
| <b>3.9</b>  | <b>Main Frequency Reference</b> .....                      | <b>61</b>  |
|             | DIP Switch S1 Analog Input Signal Selection .....          | 61         |
| <b>3.10</b> | <b>Wiring Checklist</b> .....                              | <b>62</b>  |
| <b>4.</b>   | <b>START-UP PROGRAMMING &amp; OPERATION</b> .....          | <b>63</b>  |
| <b>4.1</b>  | <b>Section Safety</b> .....                                | <b>64</b>  |
| <b>4.2</b>  | <b>Drive Start-Up Preparation</b> .....                    | <b>66</b>  |
|             | Start-Up Checklist .....                                   | 66         |
| <b>4.3</b>  | <b>Powering Up the Drive</b> .....                         | <b>68</b>  |
|             | Powering Up the Drive and Operation Status Display.....    | 68         |
| <b>4.4</b>  | <b>Using the Standard Digital LED Operator</b> .....       | <b>69</b>  |
|             | Keys, Displays, and LEDs .....                             | 69         |
|             | LED Screen Displays .....                                  | 70         |
|             | AUTO LED and HAND LED Indications .....                    | 70         |
|             | Menu Structure for Digital LED Operator .....              | 72         |
| <b>4.5</b>  | <b>The Drive and Programming Modes</b> .....               | <b>73</b>  |
|             | Changing Parameter Settings or Values.....                 | 73         |
| <b>4.6</b>  | <b>Using the Optional HOA Keypad</b> .....                 | <b>74</b>  |
|             | Keys and Displays.....                                     | 74         |
|             | LCD Display .....  | 75         |
|             | ALARM (ALM) LED Displays.....                              | 76         |
|             | AUTO LED and HAND LED Indications .....                    | 76         |
|             | Setting the Real Time Clock.....                           | 77         |
|             | Menu Structure for HOA Keypad.....                         | 81         |
|             | Changing Parameter Settings or Values .....                | 82         |
|             | Verifying Parameter Changes: Modified Constants Menu ..... | 83         |
| <b>4.7</b>  | <b>Pump Application Presets</b> .....                      | <b>86</b>  |
|             | Parameters Set Depending on A1-03 Setting .....            | 86         |
|             | Parameters Displayed Depending on A1-06 Setting.....       | 86         |
| <b>4.8</b>  | <b>iQpump Presets and Functions</b> .....                  | <b>87</b>  |
|             | iQpump Presets.....  | 87         |
|             | iQpump Functions .....                                     | 90         |
| <b>4.9</b>  | <b>Auto-Tuning</b> .....                                   | <b>101</b> |
|             | Stationary Auto-Tuning.....                                | 101        |
|             | Before Auto-Tuning the Drive.....                          | 101        |
|             | Auto-Tuning Interruption and Fault Codes .....             | 101        |
|             | Performing Auto-Tuning .....                               | 102        |
|             | Input Data for Auto-Tuning .....                           | 102        |

|   |            |
|---|------------|
| <b>4.10 No-Load Operation Test Run</b> .....                          | <b>104</b> |
| No-Load Operation Test Run .....                                      | 104        |
| <b>4.11 Test Run with Load Connected</b> .....                        | <b>105</b> |
| Test Run with the Load Connected .....                                | 105        |
| <b>4.12 Verifying Parameter Settings and Backing Up Changes</b> ..... | <b>106</b> |
| Backing Up Parameter Values: o2-03 .....                              | 106        |
| Parameter Access Level: A1-01 .....                                   | 106        |
| Password Settings: A1-04, A1-05 .....                                 | 106        |
| Copy Function (Optional) .....  | 107        |
| <b>4.13 Test Run Checklist</b> .....                                  | <b>108</b> |
| <b>5. PARAMETER DETAILS</b> .....                                     | <b>109</b> |
| <b>5.1 A: Initialization</b> .....                                    | <b>110</b> |
| A1: Initialization .....  | 110        |
| A2: User Parameters.....  | 113        |
| <b>5.2 b: Application</b> .....                                       | <b>115</b> |
| b1: Mode of Operation.....  | 115        |
| b2: DC Injection Braking.....   | 123        |
| b4: Delay Timers .....  | 129        |
| b5: PID Control.....  | 129        |
| b6: Dwell Function.....   | 138        |
| <b>5.3 C: Tuning</b> .....  | <b>140</b> |
| C1: Acceleration and Deceleration Times .....                         | 140        |
| C2: S-Curve Characteristics.....                                      | 142        |
| C3: Slip Compensation.....  | 143        |
| C4: Torque Compensation .....   | 144        |
| C6: Carrier Frequency.....  | 145        |
| <b>5.4 d: Reference Settings</b> .....                                | <b>147</b> |
| d1: Frequency Reference.....  | 147        |
| d2: Frequency Upper/Lower Limits .....                                | 148        |
| d3: Jump Frequency.....   | 149        |
| d4: Frequency Hold and Up/Down 2 Function .....                       | 150        |
| <b>5.5 E: Motor Parameters</b> .....                                  | <b>155</b> |
| E1: V/f Characteristics.....  | 155        |
| E2: Motor 1 Parameters .....  | 159        |
| <b>5.6 F: Option Settings</b> .....                                   | <b>161</b> |
| F6: Serial Communications Option Card Settings.....                   | 161        |
| MECHATROLINK-II Parameters .....                                      | 162        |
| MECHATROLINK-III Parameters .....                                     | 162        |
| PROFIBUS-DP Parameters .....  | 162        |
| DeviceNet Parameters .....  | 162        |
| F7-01 to F7-42: EtherNet/IP and Modbus TCP/IP Option Parameters ..... | 162        |
| <b>5.7 H: Terminal Functions</b> .....                                | <b>163</b> |
| H1: Multi-Function Digital Inputs .....                               | 163        |
| H2: Multi-Function Output .....                                       | 174        |
| H4: Multi-Function Analog Output Terminals .....                      | 186        |
| H6: Pulse Train Input/Output.....                                     | 187        |
| <b>5.8 L: Protection Functions</b> .....                              | <b>189</b> |
| L1: Motor Protection Functions .....                                  | 189        |

|   |            |
|---|------------|
| L2: Momentary Power Loss Ride-Thru.....                               | 193        |
| L3: Stall Prevention .....  | 197        |
| L4: Speed Agree/Frequency Reference Loss Detection .....              | 202        |
| L5: Fault Restart.....  | 204        |
| L6: Torque Detection.....   | 205        |
| L8: Hardware Protection.....  | 207        |
| <b>5.9 n: Special Adjustments.....</b>                                | <b>213</b> |
| n1: Hunting Prevention .....  | 213        |
| n3: Overexcitation Braking .....                                      | 213        |
| <b>5.10 o: Operator Related Settings.....</b>                         | <b>215</b> |
| o1: Display Settings and Selections .....                             | 215        |
| o2: Operator Key Selections .....                                     | 217        |
| o3: Copy Function .....   | 219        |
| o4: Maintenance Monitor Settings.....                                 | 220        |
| <b>5.11 P: Pump.....</b>  | <b>223</b> |
| P1: Pump Basic.....   | 223        |
| P2: Pump Protection .....   | 228        |
| P4: Pump Advanced.....  | 232        |
| P5: Pump HAND Mode .....  | 235        |
| P7: Anti-Jam.....   | 236        |
| P9: Network Options .....   | 238        |
| <b>5.12 Q: PID Controller .....</b>                                   | <b>245</b> |
| Q1: Preset Setpoint.....  | 245        |
| Q3: Output Current Limit .....  | 245        |
| S6: Drive Protection .....  | 246        |
| T: Motor Tuning .....   | 246        |
| <b>5.13 U: Monitor Parameters .....</b>                               | <b>247</b> |
| U1: Operation Status Monitors .....                                   | 247        |
| U2: Fault Trace.....  | 247        |
| U3: Fault History.....  | 247        |
| U4: Maintenance Monitors .....  | 247        |
| U5: PID Monitors .....  | 247        |
| U6: Control Monitors .....  | 247        |
| U9: Operation Status Monitors .....                                   | 247        |
| <b>6. TROUBLESHOOTING.....</b>  | <b>249</b> |
| <b>6.1 Section Safety.....</b>  | <b>250</b> |
| <b>6.2 Drive Faults, Alarms, Errors, and Messages .....</b>           | <b>252</b> |
| Types of Faults, Alarms, and Errors.....                              | 252        |
| <b>6.3 Fault Detection .....</b>                                      | <b>253</b> |
| Fault Displays, Causes, and Possible Solutions .....                  | 253        |
| <b>6.4 Alarm Detection .....</b>                                      | <b>268</b> |
| Alarm Codes, Causes, and Possible Solutions .....                     | 268        |
| <b>6.5 Operator Programming Errors .....</b>                          | <b>280</b> |
| Operator Programming Error Codes, Causes, and Possible Solutions..... | 280        |
| <b>6.6 Copy Function Related Displays .....</b>                       | <b>283</b> |
| Tasks, Errors, and Troubleshooting .....                              | 283        |
| <b>6.7 Digital Operator Display Messages .....</b>                    | <b>285</b> |
| Fault Reset Methods .....   | 286        |

|   |            |
|---|------------|
| <b>7. PERIODIC INSPECTION &amp; MAINTENANCE</b> .....                   | <b>287</b> |
| <b>7.1 Section Safety</b> .....   | <b>288</b> |
| <b>7.2 Inspection</b> .....   | <b>290</b> |
| Recommended Periodic Inspection.....                                    | 290        |
| <b>7.3 Periodic Maintenance</b> .....                                   | <b>292</b> |
| Replacement Parts.....  | 292        |
| <b>7.4 Drive Cooling Fans</b> .....                                     | <b>294</b> |
| Number of IP20/NEMA 1, UL Type 1 Cooling Fans.....                      | 294        |
| IP20/NEMA 1, UL Type 1 Cooling Fan Replacement .....                    | 295        |
| Cooling Fan Replacement.....  | 295        |
| Number of IP66/NEMA 4X, UL Type 4X Cooling Fans .....                   | 297        |
| IP66/NEMA 4X, UL Type 4X Cooling Fan Replacement.....                   | 297        |
| <b>7.5 Drive Replacement</b> .....                                      | <b>301</b> |
| Serviceable Parts .....   | 301        |
| Terminal Board Overview.....  | 301        |
| Dismantling the Removable Terminal Block.....                           | 301        |
| Details on Terminal Board (TB) or Control Board (CNT) Replacement ..... | 304        |
| <b>A. SPECIFICATIONS</b> .....  | <b>307</b> |
| <b>A.1 Power Ratings</b> .....  | <b>308</b> |
| Single-Phase 200 V Class Drives .....                                   | 308        |
| Three-Phase 200 V Class Drives .....                                    | 309        |
| Three-Phase 400 V Class Drives .....                                    | 310        |
| <b>A.2 Drive Specifications</b> .....                                   | <b>311</b> |
| <b>A.3 Drive Watt Loss Data</b> .....                                   | <b>313</b> |
| <b>A.4 Drive Derating Data</b> .....                                    | <b>314</b> |
| Single-Phase Derating .....   | 314        |
| Temperature Derating .....  | 315        |
| Altitude Derating.....  | 315        |
| <b>B. PARAMETER LIST</b> .....  | <b>317</b> |
| <b>B.1 Parameter Groups</b> .....                                       | <b>318</b> |
| <b>B.2 A: Initialization Parameters</b> .....                           | <b>319</b> |
| A1: Initialization .....  | 319        |
| A2: User Parameters.....  | 319        |
| <b>B.3 b: Application</b> .....   | <b>320</b> |
| b1: Operation Mode Selection.....                                       | 320        |
| b2: DC Injection Braking and Short Circuit Braking.....                 | 321        |
| b3: Speed Search.....   | 321        |
| b4: Timer Function .....  | 322        |
| b5: PID Control.....  | 322        |
| b6: Dwell Function.....   | 324        |
| <b>B.4 C: Tuning</b> .....  | <b>325</b> |
| C1: Acceleration and Deceleration Times .....                           | 325        |
| C2: S-Curve Characteristics.....  | 325        |
| C3: Slip Compensation.....  | 326        |
| C4: Torque Compensation .....   | 326        |
| C6: Carrier Frequency.....  | 326        |

|  |            |
|--|------------|
| <b>B.5 d: References</b> .....                           | <b>327</b> |
| d1: Frequency Reference.....                             | 327        |
| d2: Frequency Upper/Lower Limits .....                   | 328        |
| d3: Jump Frequency.....                                  | 328        |
| d4: Frequency Reference Hold and Up/Down 2 Function..... | 329        |
| <b>B.6 E: Motor Parameters</b> .....                     | <b>330</b> |
| E1: V/f Pattern .....                                    | 330        |
| E2: Motor 1 Parameters .....                             | 331        |
| <b>B.7 F: Options</b> .....                              | <b>333</b> |
| F6, F7: Communication Option Card.....                   | 333        |
| <b>B.8 H Parameters: Multi-Function Terminals</b> .....  | <b>335</b> |
| H1: Multi-Function Digital Inputs .....                  | 335        |
| H2: Multi-Function Digital Outputs.....                  | 339        |
| H3: Multi-Function Analog Inputs .....                   | 341        |
| H4: Analog Outputs .....                                 | 343        |
| H5: MEMOBUS/Modbus Serial Communication .....            | 343        |
| H6: Pulse Train Input.....                               | 344        |
| <b>B.9 L: Protection Function</b> .....                  | <b>345</b> |
| L1: Motor Protection .....                               | 345        |
| L2: Momentary Power Loss Ride-Thru.....                  | 346        |
| L3: Stall Prevention .....                               | 346        |
| L4: Speed Detection.....                                 | 348        |
| L5: Fault Restart.....                                   | 348        |
| L6: Torque Detection.....                                | 349        |
| L8: Drive Protection.....                                | 350        |
| <b>B.10 n: Advanced Performance Set-Up</b> .....         | <b>352</b> |
| n1: Hunting Prevention.....                              | 352        |
| n3: Overexcitation Braking .....                         | 352        |
| <b>B.11 o: Operator Related Parameters</b> .....         | <b>353</b> |
| o1: HOA Keypad Display Selection.....                    | 353        |
| o2: HOA Keypad Keypad Functions.....                     | 354        |
| o3: Copy Function .....                                  | 354        |
| o4: Maintenance Monitor Settings.....                    | 355        |
| <b>B.12 P: Pump Parameters</b> .....                     | <b>356</b> |
| P1: Pump Basic.....                                      | 356        |
| P2: Pump Protection .....                                | 358        |
| P4: Pump Advanced.....                                   | 359        |
| P5: Pump HAND Mode .....                                 | 361        |
| P7: Anti-Jam.....  | 362        |
| P9: Network Options .....                                | 362        |
| <b>B.13 Q: PID Controller Parameters</b> .....           | <b>366</b> |
| Q1: Preset Setpoint.....                                 | 366        |
| Q3: Output Current Limit .....                           | 366        |
| <b>B.14 S: Special Application</b> .....                 | <b>367</b> |
| S6: Protection.....                                      | 367        |
| <b>B.15 T: Motor Tuning</b> .....                        | <b>368</b> |
| T1: Induction Motor Auto-Tuning.....                     | 368        |
| <b>B.16 U: Monitors</b> .....                            | <b>369</b> |
| U1: Operation Status Monitors .....                      | 369        |



|  |            |
|--|------------|
| U2: Fault Trace.....                                 | 372        |
| U3: Fault History.....                               | 372        |
| U4: Maintenance Monitors .....                       | 374        |
| U5: PID Monitors .....                               | 376        |
| U6: Control Monitors .....                           | 376        |
| U9: Operation Status Monitors .....                  | 376        |
| <b>B.17 Defaults by Drive Model.....</b>             | <b>377</b> |
| <b>C. MEMOBUS/MODBUS COMMUNICATIONS.....</b>         | <b>383</b> |
| <b>C.1 Section Safety.....</b>                       | <b>384</b> |
| <b>C.2 MEMOBUS/Modbus Configuration .....</b>        | <b>385</b> |
| <b>C.3 Communication Specifications .....</b>        | <b>386</b> |
| <b>C.4 Connecting to a Network .....</b>             | <b>387</b> |
| Network Cable Connection.....                        | 387        |
| Wiring Diagram for Multiple Connections .....        | 388        |
| Network Termination .....                            | 390        |
| <b>C.5 MEMOBUS/Modbus Setup Parameters .....</b>     | <b>391</b> |
| MEMOBUS/Modbus Serial Communication.....             | 391        |
| <b>C.6 Drive Operations by MEMOBUS/Modbus.....</b>   | <b>395</b> |
| Observing the Drive Operation.....                   | 395        |
| Controlling the Drive.....                           | 395        |
| <b>C.7 Communications Timing.....</b>                | <b>396</b> |
| Command Messages from Master to Drive.....           | 396        |
| Response Messages from Drive to Master .....         | 396        |
| <b>C.8 Message Format .....</b>                      | <b>397</b> |
| Message Content .....                                | 397        |
| Slave Address .....                                  | 397        |
| Function Code.....                                   | 397        |
| Data.....  | 397        |
| Error Check .....                                    | 397        |
| <b>C.9 Message Examples .....</b>                    | <b>399</b> |
| Reading Drive MEMOBUS/Modbus Register Contents ..... | 399        |
| Loopback Test.....                                   | 399        |
| Writing to Multiple Registers.....                   | 400        |
| <b>C.10 MEMOBUS/Modbus Data Table.....</b>           | <b>401</b> |
| Command Data .....                                   | 401        |
| Monitor Data.....                                    | 403        |
| Broadcast Messages.....                              | 412        |
| Fault Trace Contents.....                            | 412        |
| Alarm Register Contents .....                        | 413        |
| <b>C.11 Enter Command.....</b>                       | <b>415</b> |
| Enter Command Types .....                            | 415        |
| <b>C.12 Communication Errors .....</b>               | <b>416</b> |
| MEMOBUS/Modbus Error Codes.....                      | 416        |
| Slave Not Responding.....                            | 416        |
| <b>C.13 Self-Diagnostics .....</b>                   | <b>417</b> |
| <b>D. STANDARDS COMPLIANCE .....</b>                 | <b>419</b> |

|  |            |
|--|------------|
| <b>D.1 Section Safety</b> .....                            | <b>420</b> |
| <b>D.2 European Standards</b> .....                        | <b>422</b> |
| CE Low Voltage Directive Compliance.....                   | 422        |
| EMC Guidelines Compliance .....                            | 424        |
| <b>D.3 UL and CSA Standards</b> .....                      | <b>427</b> |
| UL Standards Compliance .....                              | 427        |
| CSA Standards Compliance.....                              | 432        |
| Drive Motor Overload Protection .....                      | 432        |
| Safe Disable Function Description .....                    | 433        |
| Installation .....   | 433        |
| <b>D.1 UL Standards</b> .....                              | <b>435</b> |
| UL Standards Compliance .....                              | 435        |
| IP66/NEMA 4X, UL Type 4X Conditions of Acceptability ..... | 435        |
| Main Circuit Terminal Wiring .....                         | 435        |
| Drive Motor Overload Protection .....                      | 440        |

# Preface & General Safety

---

This section provides safety messages pertinent to this product that, if not heeded, may result in fatality, personal injury, or equipment damage. Yaskawa is not responsible for the consequences of ignoring these instructions.

|            |                            |           |
|------------|----------------------------|-----------|
| <b>i.1</b> | <b>PREFACE.....</b>        | <b>12</b> |
| <b>i.2</b> | <b>GENERAL SAFETY.....</b> | <b>13</b> |

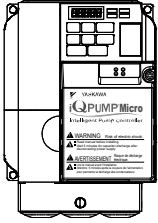
## i.1 Preface

Yaskawa manufactures products used as components in a wide variety of industrial systems and equipment. The selection and application of Yaskawa products remain the responsibility of the equipment manufacturer or end user. Yaskawa accepts no responsibility for the way its products are incorporated into the final system design. Under no circumstances should any Yaskawa product be incorporated into any product or design as the exclusive or sole safety control. Without exception, all controls should be designed to detect faults dynamically and fail safely under all circumstances. All systems or equipment designed to incorporate a product manufactured by Yaskawa must be supplied to the end user with appropriate warnings and instructions as to the safe use and operation of that part. Any warnings provided by Yaskawa must be promptly provided to the end user. Yaskawa offers an express warranty only as to the quality of its products in conforming to standards and specifications published in the Yaskawa manual. **NO OTHER WARRANTY, EXPRESS OR IMPLIED, IS OFFERED.** Yaskawa assumes no liability for any personal injury, property damage, losses, or claims arising from misapplication of its products.

This manual is designed to ensure correct and suitable application of drives. Read this manual before attempting to install, operate, maintain, or inspect a drive and keep it in a safe, convenient location for future reference. Be sure you understand all precautions and safety information before attempting application.

### ◆ Applicable Documentation

The following manuals are available for iQpump Micro drives:

|  |  |
|--|--|
|  | <p>iQpump Micro Quick Start Procedure (TOEPYAIQPM01)</p> <p>This sheet is packaged together with the drive and contains a step-by-step guide to enable the user to properly wire the drive and motor and connect the 24 V power supply.</p>  |
|  | <p>iQpump Micro AC Drive Quick Start Guide (TOEPYAIQPM02)</p> <p>Read this guide first. This guide is packaged together with the product and contains basic information required to install and wire the drive. It also gives an overview of fault diagnostics, maintenance, and parameter settings. The purpose of this guide is to prepare the drive for basic operation. The most recent version of this manual is available for download on our documentation website, <a href="http://www.yaskawa.com">www.yaskawa.com</a>.</p> |
|  | <p>iQpump Micro AC Drive User Manual (TOEPYAIQPM03)</p> <p>This manual provides detailed information on parameter settings, fault diagnostics, and drive functions. Use this manual to expand drive functionality and to take advantage of higher performance features. The most recent version of this manual is available for download on our documentation website, <a href="http://www.yaskawa.com">www.yaskawa.com</a>.</p>   |

### ◆ Symbols

**Note:** Indicates a supplement or precaution that does not cause drive damage.



Indicates a term or definition used in this manual.

### ◆ Terms and Abbreviations

- **Drive:** Yaskawa iQpump Micro Intelligent Pump Controller
- **BCD:** Binary Coded Decimal
- **H:** Hexadecimal Number Format
- **IGBT:** Insulated Gate Bipolar Transistor
- **kbps:** Kilobits per Second
- **MAC:** Media Access Control
- **Mbps:** Megabits per Second
- **r/min:** Revolutions per Minute
- **V/f:** V/f Control

### ◆ Trademarks

- Modbus is a trademark of Schneider Electric.
- Other companies and product names mentioned in this manual are trademarks of those companies.

## i.2 General Safety

### ◆ Supplemental Safety Information

#### General Precautions

- The diagrams in this manual may be indicated without covers or safety shields to show details. Replace the covers or shields before operating the drive and run the drive according to the instructions described in this manual.
- Any illustrations, photographs, or examples used in this manual are provided as examples only and may not apply to all products to which this manual is applicable.
- The products and specifications described in this manual or the content and presentation of the manual may be changed without notice to improve the product and/or the manual.
- When ordering a new copy of the manual due to damage or loss, contact your Yaskawa representative or the nearest Yaskawa sales office and provide the manual number shown on the front cover.
- If nameplate becomes worn or damaged, order a replacement from your Yaskawa representative or the nearest Yaskawa sales office.

#### WARNING

Read and understand this manual before installing, operating or servicing this drive. The drive must be installed according to this manual and local codes.

The following conventions are used to indicate safety messages in this manual. Failure to heed these messages could result in serious or fatal injury or damage to the products or to related equipment and systems.

#### DANGER

Indicates a hazardous situation, which, if not avoided, will result in death or serious injury.

#### WARNING

Indicates a hazardous situation, which, if not avoided, could result in death or serious injury.

**WARNING!** *may also be indicated by a bold key word embedded in the text followed by an italicized safety message.*

#### CAUTION

Indicates a hazardous situation, which, if not avoided, could result in minor or moderate injury.

**CAUTION!** *may also be indicated by a bold key word embedded in the text followed by an italicized safety message.*

#### NOTICE

Indicates a property damage message.

**NOTICE:** *may also be indicated by a bold key word embedded in the text followed by an italicized safety message.*

### ◆ Safety Messages

#### DANGER

##### **Heed the safety messages in this manual.**

Failure to comply will result in death or serious injury.

The operating company is responsible for any injuries or equipment damage resulting from failure to heed the warnings in this manual.

#### **Electrical Shock Hazard**

##### **Before servicing, disconnect all power to the equipment.**

The internal capacitor remains charged even after the power supply is turned off. The charge indicator LED will extinguish when the DC bus voltage is below 50 Vdc. To prevent electric shock, wait for at least the time specified on the warning label, once all indicators are OFF, measure for unsafe voltages to confirm the drive is safe prior to servicing.

Failure to comply will result in death or serious injury.

#### WARNING

#### **Sudden Movement Hazard**

##### **System may start unexpectedly upon application of power, resulting in death or serious injury.**

Clear all personnel from the drive, motor and machine area before applying power. Secure covers, couplings, shaft keys and machine loads before applying power to the drive.

#### **Electrical Shock Hazard**

##### **Do not attempt to modify or alter the drive in any way not explained in this manual.**

Failure to comply could result in death or serious injury.

Yaskawa is not responsible for any modification of the product made by the user. This product must not be modified.

##### **Do not allow unqualified personnel to use equipment.**

Failure to comply could result in death or serious injury.

Installation, maintenance, inspection, and service must be performed only by authorized personnel familiar with installation, adjustment and maintenance of AC drives.

##### **Do not remove covers or touch circuit boards while the power is on.**

Failure to comply could result in death or serious injury.

##### **Make sure the protective earthing conductor complies with technical standards and local safety regulations.**

##### **Always use appropriate equipment for Ground Fault Circuit Interrupters (GFCIs).**

The drive can cause a residual current with a DC component in the protective earthing conductor. Where a residual current operated protective or monitoring device is used for protection in case of direct or indirect contact, always use a type B GFCI according to IEC/EN 60755.

#### **Fire Hazard**

##### **Do not use an improper voltage source.**

Failure to comply could result in death or serious injury by fire.

Verify that the rated voltage of the drive matches the voltage of the incoming power supply before applying power.

##### **Install adequate branch circuit protection according to applicable local codes and this Installation Manual. Failure to comply could result in fire and damage to the drive or injury to personnel.**

The device is suitable for use on a circuit capable of delivering not more than 100,000 RMS symmetrical amperes, 240 Vac maximum (200 V class) and 480 Vac maximum (400 V class) when protected by branch circuit protection devices specified in this document.

**⚠ WARNING****Crush Hazard**

**Do not use this drive in lifting applications without installing external safety circuitry to prevent accidental dropping of the load.**

**The drive does not possess built-in load drop protection for lifting applications.**

Failure to comply could result in death or serious injury from falling loads.

Install electrical and/or mechanical safety circuit mechanisms independent of drive circuitry.

**⚠ CAUTION****Crush Hazard**

**Do not carry the drive by the front cover.**

Failure to comply may result in minor or moderate injury from the main body of the drive falling.

**NOTICE**

**Observe proper electrostatic discharge procedures (ESD) when handling the drive and circuit boards. Failure to comply may result in ESD damage to the drive circuitry.**

**Do not perform a withstand voltage test or megger test on any part of the drive.**

Failure to comply could result in damage to the sensitive devices within the drive.

**Do not operate damaged equipment.**

Failure to comply could result in further damage to the equipment. Do not connect or operate any equipment with visible damage or missing parts.

**If a fuse is blown or a Ground Fault Circuit Interrupter (GFCI) is tripped, check the wiring and the selection of the peripheral devices.**

Check for short circuits or ground faults on the secondary side of fuses and GFCIs and check the wiring and the selection of peripheral devices. Remove the cause of the problem and then turn the power supply off and on again. If the cause cannot be identified, do not turn on the power supply or attempt to operate the equipment.

**Do not restart the drive immediately operate the peripheral devices if a fuse is blown or a GFCI is tripped.**

Check the wiring and the selection of peripheral devices to identify the cause. Contact your supplier before restarting the drive or the peripheral devices if the cause cannot be identified.

**Do not expose the drive to halogen group disinfectants.**

Failure to comply may cause damage to the electrical components in the drive.

Do not pack the drive in wooden materials that have been fumigated or sterilized. Do not sterilize the entire package after the product is packed.

**◆ General Application Precautions****■ Selection****Installing a Reactor**

Use an AC reactor or DC link choke in the following situations:

- to suppress harmonic current.
- to smooth peak current that results from capacitor switching.
- when the power supply is above 600 kVA.
- when the drive is running from a power supply system with thyristor converters.

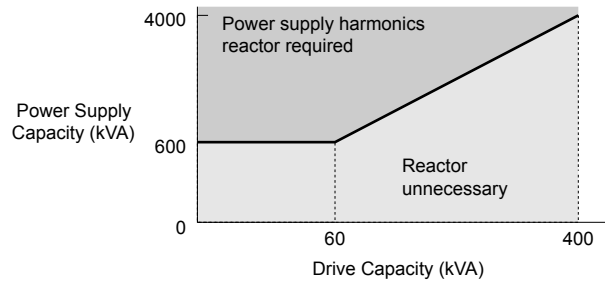


Figure i.1 Installing a Reactor

### Drive Capacity

For specialized motors, make sure that the motor rated current is less than the rated output current for the drive.

When running more than one motor in parallel from a single drive, the capacity of the drive should be larger than [total motor rated current  $\times$  1.1].

### Starting Torque

The overload rating of the drive determines the starting and accelerating characteristics of the motor. Expect lower running torque than when running the motor from line power. To get more starting torque, use a larger drive or increase both the motor and drive capacity.

### Emergency/Fast Stop

During a drive fault condition, a protective circuit is activated and drive output is shut off. The motor may coast to a stop or attempt to decelerate depending on parameter settings. If the emergency/fast stop cannot stop the load as fast as desired, a customer-supplied mechanical brake may be required. Test emergency stop circuitry before putting drive into operation.

### ■ Repetitive Starting/Stopping

Applications with frequent starts and stops often exceed 150% of their rated current values. Heat stress generated from repetitive high current can shorten the life span of the IGBTs. The expected lifetime for the IGBTs is about 8 million start and stop cycles with a 4 kHz carrier frequency and a 150% peak current.

Yaskawa recommends lowering the carrier frequency, particularly when audible noise is not a concern. The user can also choose to reduce the load, increase the acceleration and deceleration times, or switch to a larger drive. This will help keep peak current levels under 150%. Be sure to check the peak current levels when starting and stopping repeatedly during the initial test run, and make adjustments accordingly.

### ■ Installation

#### Enclosure Panels

Keep the drive in a clean environment by installing the drive in an enclosure panel or selecting an installation area free of airborne dust, lint, and oil mist. Be sure to leave the required space between drives to provide for cooling, and take proper measures so the ambient temperature remains within allowable limits and keep flammable materials away from the drive. Yaskawa offers protective designs for drives that must be used in areas subjected to oil mist and excessive vibration. Contact Yaskawa or your Yaskawa agent for details.

#### Installation Direction

**NOTICE:** Install the drive upright as specified in the manual. [Refer to Mechanical Installation on page 28](#) for more information on installation. Failure to comply may damage the drive due to improper cooling.

### ■ Settings

#### Upper Limits

**NOTICE:** The drive is capable of running the motor up to 400 Hz. Be sure to set the upper limit for the frequency of the drive to prevent the possible danger of accidentally operating equipment at higher than rated speed. The default setting for the maximum output frequency is 60 Hz.

#### Lower Limits

**NOTICE:** Many pumps have a minimum safe operating speed. Be sure to properly set the minimum pump speed in to protect the pump from damage.

#### DC Injection Braking

**NOTICE:** Excessive current during DC Injection Braking and excessive duration of DC Injection Braking can cause motor overheat.



### Acceleration/Deceleration Times

Acceleration and deceleration times are affected by the amount of torque generated by the motor, the load torque, and the inertia moment. Set a longer accel/decel time when Stall Prevention is enabled. The accel/decel times are lengthened for as long as the Stall Prevention function is in operation.

## ■ General Handling

### Wiring Check

**NOTICE:** Do not connect power supply lines to output terminals U/T1, V/T2, or W/T3. Failure to comply will destroy the drive. Be sure to perform a final check of all sequence wiring and other connections before turning on the power and also check for short circuits on the control terminals, which may damage the drive.

### Selecting a Circuit Breaker or Circuit Interrupter

Yaskawa recommends installing a Ground Fault Circuit Interrupter (GFCI) to the power supply side. The GFCI should be designed for use with AC drives (e.g., Type B according to IEC 60755).

Select a Molded Case Circuit Breaker (MCCB) or GFCI with a rated current 1.5 to 2 times higher than the drive rated input current to avoid nuisance trips caused by harmonics in the drive input current.

### Magnetic Contactor Installation

**NOTICE:** To get the full performance life out of the electrolytic capacitors and circuit relays, refrain from switching the drive power supply off and on more than once every 30 minutes. Frequent use can damage the drive. Use the drive to stop and start the motor.

### Inspection and Maintenance

**WARNING!** Electrical Shock Hazard. Capacitors in the drive do not immediately discharge after shutting off the power. Wait for at least the amount of time specified on the drive before touching any components after shutting off the power. Failure to comply may cause injury to personnel from electrical shock.

**WARNING!** Burn Hazard. Because the heatsink can get very hot during operation, take proper precautions to prevent burns. When replacing the cooling fan, shut off the power and wait at least 15 minutes to be sure that the heatsink has cooled down. Failure to comply may cause burn injury to personnel.

### Wiring

Yaskawa recommends using ring terminals on all drive models. UL/cUL approval requires the use of UL Listed closed-loop crimp terminals when wiring the drive main circuit terminals. Use only the tools recommended by the terminal manufacturer for crimping.

### Transporting the Drive

**NOTICE:** Never steam clean the drive. During transport, keep the drive from coming into contact with salts, fluorine, bromine, phthalate ester, and other such harmful chemicals.

---

## ◆ Motor Application Precautions

### ■ Standard Induction Motors

#### Low Speed Range

The cooling fan of a standard motor is usually designed to sufficiently cool the motor at the rated speed. As the self-cooling capability of such a motor reduces with the speed, applying full torque at low speed will possibly damage the motor. To prevent motor damage from overheat, reduce the load torque as the motor slows. [Figure i.2](#) shows the allowable load characteristics for a Yaskawa standard motor. A motor designed specifically for operation with a drive should be used when 100% continuous torque is needed at low speeds.

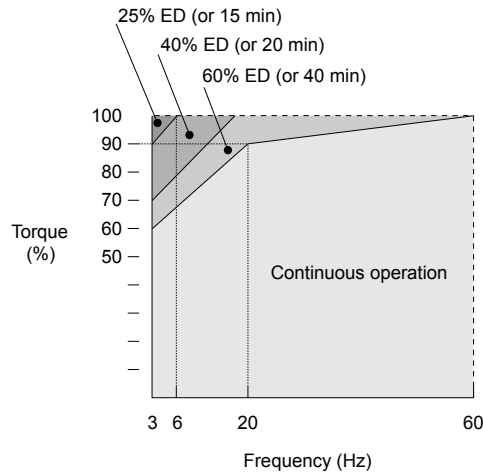


Figure i.2 Allowable Load Characteristics for a Yaskawa Motor

### Insulation Tolerance

**NOTICE:** Consider motor voltage tolerance levels and motor insulation in applications with an input voltage of over 440 V or particularly long wiring distances.

### High-Speed Operation

**NOTICE:** Problems may occur with the motor bearings and dynamic balance of the machine when operating a motor beyond its rated speed. Contact the motor or machine manufacturer.

### Torque Characteristics

Torque characteristics differ compared to operating the motor directly from line power. The user should have a full understanding of the load torque characteristics for the application.

### Vibration and Shock

The drive allows selection of high carrier PWM control and low carrier PWM. Selecting high carrier PWM can help reduce motor oscillation (drive current derating may be required).

Take particular caution when adding a variable speed drive to an application running a motor from line power at a constant speed. If resonance occurs, use shock absorbing mounts to the motor base and enable the Jump frequency selection to prevent continuous operation in the resonant frequency range.

### Audible Noise

The audible noise of the motor varies based on the carrier frequency setting. However, drive current derating may be required. When using a high carrier frequency, audible noise from the motor is comparable to the motor noise generated when running from line power.

## ■ Specialized Motors

### Multi-Pole Motor

Because the rated current will differ from a standard motor, be sure to check the maximum current when selecting a drive. Always stop the motor before switching between the number of motor poles. If a regen overvoltage (oV) fault occurs or if overcurrent protection (oC) is triggered, the motor will coast to stop.

### Submersible Motor

The rated current of a submersible motor is greater than that of a standard motor, so select the drive accordingly. Use a motor cable large enough to avoid decreasing the maximum torque level from voltage drop caused by a long motor cable.

### Explosion-Proof Motor

The motor and the drive must be tested together to be certified as explosion-proof. The drive is not designed for explosion-proof areas.

### Geared Motor

Make sure that the gear and the lubricant are rated for the desired speed range to avoid gear damage when operating at low speeds or very high speeds. Consult with the manufacturer for applications that require operation outside the rated speed range of the motor or gear box.

## Single-Phase Motor

Variable speed drives are not designed to operate with single phase motors. Using capacitors to start the motor causes a high-frequency current to flow to the capacitors and can damage the capacitors. A split-phase start or a repulsion start can burn out the starter coils because the internal centrifugal switch is not activated. The drive is for use with three-phase motors only.

## ■ Notes on Power Transmission Machinery

Installing an AC drive in machinery that was previously connected directly to the power supply will allow the machine to operate at variable speeds. Continuous operation outside of the rated speeds can wear out lubrication material in gear boxes and other power transmission parts. Make sure that lubrication is sufficient within the entire speed range to avoid machine damage. Note that operation above the rated speed can increase the noise generated by the machine.

## ◆ Drive Label Warning Example

Always heed the warning information listed in [Figure i.3](#).

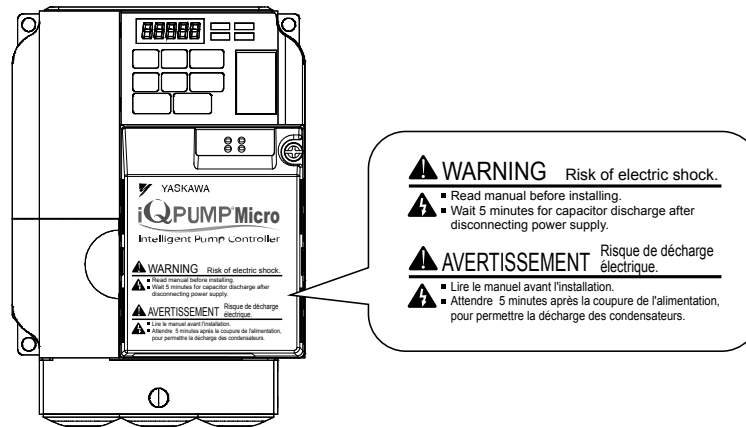


Figure i.3 Warning Information Example

## ◆ Warranty Information

### ■ Restrictions

The drive is not designed or manufactured for use in devices or systems that may directly affect or threaten human lives or health.

Customers who intend to use the product described in this manual for devices or systems relating to transportation, health care, space aviation, atomic power, electric power, or in underwater applications must first contact their Yaskawa representatives or the nearest Yaskawa sales office.

**WARNING! Injury to Personnel.** This product has been manufactured under strict quality-control guidelines. However, if this product is to be installed in any location where failure of this product could involve or result in a life-and-death situation or loss of human life or in a facility where failure may cause a serious accident or physical injury, safety devices must be installed to minimize the likelihood of any accident.

**This Page Intentionally Blank**

## Receiving

---

This chapter explains how to inspect the drive upon receipt, and gives an overview of the different enclosure types and components.

|            |  |           |
|------------|--|-----------|
| <b>1.1</b> | <b>SECTION SAFETY.....</b>                   | <b>22</b> |
| <b>1.2</b> | <b>MODEL NUMBER AND NAMEPLATE CHECK.....</b> | <b>23</b> |

## 1.1 Section Safety

### CAUTION

**Do not carry the drive by the front cover.**

Failure to comply may cause the main body of the drive to fall, resulting in minor or moderate injury.

### NOTICE

**Observe proper electrostatic discharge procedures (ESD) when handling the drive and circuit boards.**

Failure to comply may result in ESD damage to the drive circuitry.

**A motor connected to a PWM drive may operate at a higher temperature than a utility-fed motor and the operating speed range may reduce motor cooling capacity.**

Ensure that the motor is suitable for drive duty and/or the motor service factor is adequate to accommodate the additional heating with the intended operating conditions.

## 1.2 Model Number and Nameplate Check

Please perform the following tasks after receiving the drive:

- Inspect the drive for damage.
- If the drive appears damaged upon receipt, contact the shipper immediately.
- Verify receipt of the correct model by checking the information on the nameplate.
- If you have received the wrong model or the drive does not function properly, contact your supplier.

### ◆ Nameplate

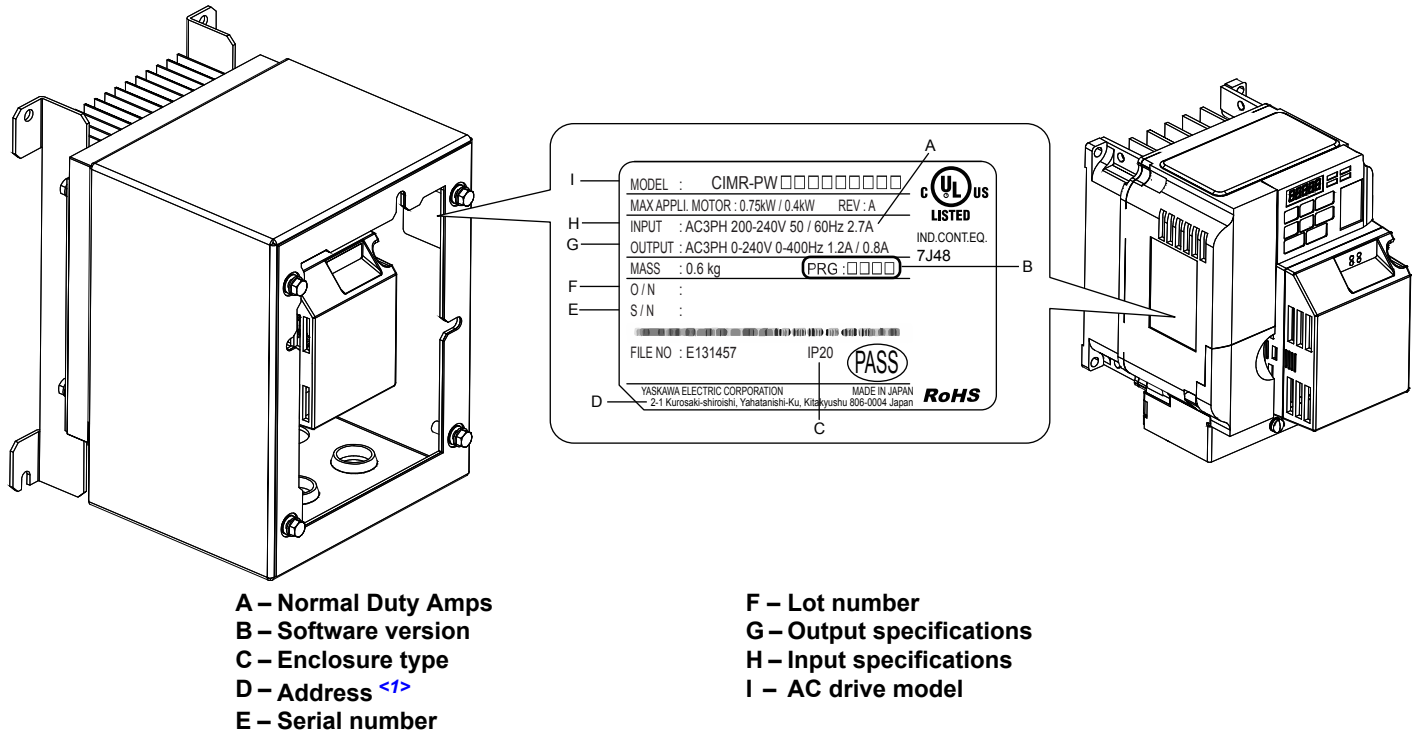
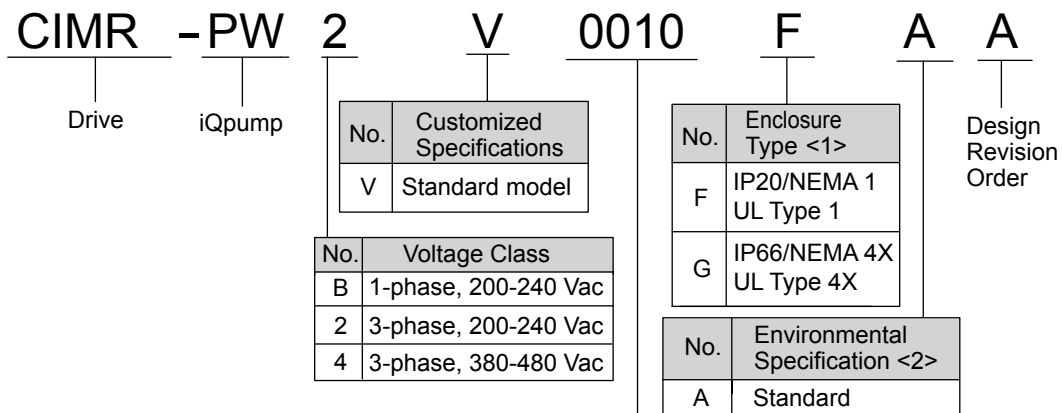


Figure 1.1 Nameplate Information Example

<1> The address of the head office of Yaskawa Electric Corporation (responsible for product liability) is shown on the nameplate.



Refer to the following tables

<1> Refer to [Mechanical Installation on page 28](#) for differences regarding enclosure protection types and component descriptions.

<2> Please contact Yaskawa for details regarding Environmental Specifications.

## 1.2 Model Number and Nameplate Check

### ■ Single-Phase 200 V Class

| Drive Model | Max. Motor Capacity kW (HP) | Rated Output Current A |
|-------------|-----------------------------|------------------------|
| BV0006      | 1.1 (1)                     | 6.0                    |
| BV0010      | 2.2 (3)                     | 9.6                    |
| BV0012      | 3.0 (3)                     | 12.0                   |
| BV0018      | 3.7 (5)                     | 17.5                   |

### ■ Three-Phase 200 V Class

| Drive Model | Max. Motor Capacity kW (HP) | Rated Output Current A |
|-------------|-----------------------------|------------------------|
| 2V0006      | 1.1 (1.5)                   | 6.0                    |
| 2V0010      | 2.2 (3)                     | 9.6                    |
| 2V0012      | 3.0 (3)                     | 12.0                   |
| 2V0020      | 5.5 (5)                     | 19.6                   |
| 2V0030      | 7.5 (10)                    | 30.0                   |
| 2V0040      | 11 (10)                     | 40.0                   |
| 2V0056      | 15 (20)                     | 56.0                   |
| 2V0069      | 18.5 (25)                   | 69.0                   |

### ■ Three-Phase 400 V Class

| Drive Model | Max. Motor Capacity kW (HP) | Rated Output Current A |
|-------------|-----------------------------|------------------------|
| 4V0002      | 0.75 (1)                    | 2.1                    |
| 4V0004      | 1.5 (2)                     | 4.1                    |
| 4V0005      | 2.2 (3)                     | 5.4                    |
| 4V0007      | 3.0 (3)                     | 6.9                    |
| 4V0009      | 3.7 (5)                     | 8.8                    |
| 4V0011      | 5.5 (7.5)                   | 11.1                   |
| 4V0018      | 7.5 (10)                    | 17.5                   |
| 4V0023      | 11 (15)                     | 23.0                   |
| 4V0031      | 15 (20)                     | 31.0                   |
| 4V0038      | 18.5 (25)                   | 38.0                   |



## Mechanical Installation

---

This chapter explains how to properly mount and install the drive.

|            |                                     |           |
|------------|-------------------------------------|-----------|
| <b>2.1</b> | <b>SECTION SAFETY.....</b>          | <b>26</b> |
| <b>2.2</b> | <b>MECHANICAL INSTALLATION.....</b> | <b>28</b> |

## 2.1 Section Safety

### WARNING

#### Fire Hazard

**Provide sufficient cooling when installing the drive inside an enclosed panel or cabinet.**

Failure to comply could result in overheating and fire.

When multiple drives are placed inside the same enclosure panel, install proper cooling to ensure air entering the enclosure does not exceed 40 °C.

### CAUTION

#### Crush Hazard

**Do not carry the drive by the front cover.**

Failure to comply may result in minor or moderate injury from the main body of the drive falling.

### NOTICE

**Observe proper electrostatic discharge (ESD) procedures when handling the drive.**

Failure to comply could result in ESD damage to the drive circuitry.

**It may be difficult to perform maintenance on the cooling fans of drives installed in a vertical row inside an enclosure.**

Ensure adequate spacing at the top of the drive to perform cooling fan replacement when required.

**Operating the motor in the low-speed range diminishes the cooling effects, increases motor temperature, and may lead to motor damage by overheating.**

Reduce the motor torque in the low-speed range whenever using a standard blower cooled motor. If 100% torque is required continuously at low speed, consider using a special drive or vector motor. Select a motor that is compatible with the required load torque and operating speed range.

**Do not operate motors above the maximum rated RPM.**

Failure to comply may lead to bearing or other mechanical motor failures.

**The speed range for continuous operation differs according to the lubrication method and motor manufacturer.**

If the motor is to be operated at a speed higher than the rated speed, consult with the manufacturer.

Continuously operating an oil-lubricated motor in the low-speed range may result in burning.

**NOTICE**

**When the wiring distance is greater than 100 meters, pay special attention to the motor insulation voltage or use a drive-rated motor.**

Failure to comply could lead to motor winding failure.

**Motor vibration may increase when operating a machine in variable-speed mode, if that machine previously operated at a constant speed.**

Install vibration-proof rubber on the motor base or use the frequency jump function to skip a frequency resonating the machine.

**The motor may require more acceleration torque with drive operation than with a commercial power supply.**

Set a proper V/f pattern by checking the load torque characteristics of the machine to be used with the motor.

**The rated input current of submersible motors is higher than the rated input current of standard motors.**

Select an appropriate drive according to its rated output current. When the distance between the motor and drive is long, use a cable thick enough to connect the motor to the drive to prevent motor torque reduction.

**When using an explosion-proof motor, it must be subject to an explosion-proof test in conjunction with the drive.**

This is also applicable when an existing explosion-proof motor is to be operated with the drive. Since the drive itself is not explosion-proof, always install it in a safe place. Be sure to set A1-02 to "0" when using an explosion-proof motor.

**Do not use a drive for a single-phase motor.**

Replace the motor with a three-phase motor.

**If an oil-lubricated gearbox or speed reducer is used in the power transmission mechanism, oil lubrication will be affected when the motor operates only in the low speed range.**

The power transmission mechanism will make noise and experience problems with service life and durability if the motor is operated at a speed higher than the rated speed.

# 2.2 Mechanical Installation

This section outlines specifications, procedures, and environment for proper mechanical installation of the drive.

### ◆ Installation Environment

To help prolong the optimum performance life of the drive, install the drive in the proper environment. [Table 2.1](#) describes the appropriate environment for the drive.

**Table 2.1 Installation Environment**

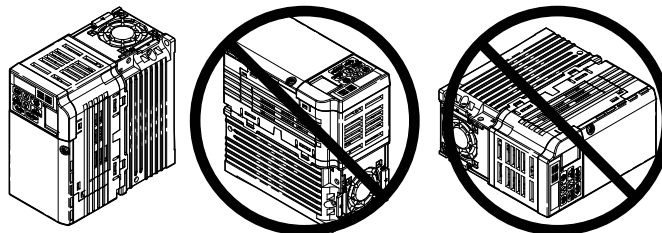
| Environment         | Conditions   |
|---------------------|--|
| Installation Area   | Indoors  |
| Ambient Temperature | IP20/NEMA 1, UL Type 1 enclosure: -10 °C to +40 °C (14 °F to 104 °F)<br>IP66/NEMA 4X, UL Type 4X enclosure: -10 °C to +40 °C (14 °F to 104 °F)<br>Drive reliability improves in environments without wide temperature fluctuations.<br>When using an enclosure panel, install a cooling fan or air conditioner in the area to ensure that the air temperature inside the enclosure does not exceed the specified levels.<br>Do not allow ice to develop on the drive.  |
| Humidity            | 95% RH or less and free of condensation  |
| Storage Temperature | -20 °C to +60 °C (-4 °F to +104 °F)  |
| Surrounding Area    | Install the drive in an area free from: <ul style="list-style-type: none"> <li>oil mist and dust</li> <li>metal shavings, oil, water or other foreign materials</li> <li>radioactive materials</li> <li>combustible materials (e.g., wood)</li> <li>harmful gases and liquids</li> <li>excessive vibration</li> <li>chlorides</li> <li>direct sunlight</li> </ul> For IP66/NEMA 4X, UL Type 4X enclosure drives, install the drive in an environment suitable for IP66/NEMA 4X, UL Type 4X enclosures: <ul style="list-style-type: none"> <li>NEMA 4X, UL Type 4X – Enclosures constructed for either indoor or outdoor use to provide a degree of protection to personnel against incidental contact with the enclosed equipment; to provide a degree of protection against falling dirt, rain, sleet, snow, windblown dust, splashing water, hose-directed water, and corrosion; and that will be undamaged by the external formation of ice on the enclosure.</li> <li>IP66 – Dust-tight enclosures to not allow any dust to penetrate. The enclosure guards the drive against powerful jetting water sprayed from any direction and is protected against access to hazardous parts with a wire.</li> </ul> |
| Altitude            | Up to 1000 meters without derating; up to 3000 meters with output current, ambient temperature, and voltage derating.  |
| Vibration           | 10 to 20 Hz at 9.8 m/s <sup>2</sup><br>20 to 55 Hz at 5.9 m/s <sup>2</sup>   |
| Orientation         | Install the drive vertically to maintain maximum cooling effects.  |

**NOTICE:** Prevent foreign matter such as metal shavings or wire clippings from falling into the drive during installation and project construction. Failure to comply could result in damage to the drive. Place a temporary cover over the top of the drive during installation. Remove the temporary cover before startup, as the cover will reduce ventilation and cause the drive to overheat.

**NOTICE:** Avoid placing drive peripheral devices, transformers, or other electronics near the drive. Failure to comply could result in erroneous operation. If such devices must be used in close proximity to the drive, take proper steps to shield the drive from noise.

### ◆ Installation Orientation and Spacing

**NOTICE:** Install the drive upright as illustrated in [Figure 2.1](#). Failure to comply may damage the drive due to improper cooling.



**Figure 2.1 Correct Installation Orientation**

### Single Drive Installation

Figure 2.2 shows the required installation spacing to maintain sufficient space for airflow and wiring for IP20/NEMA 1, UL Type 1 and IP66/NEMA 4X, UL Type 4X enclosures. Install the heatsink against a closed surface to avoid diverting cooling air around the heatsink.

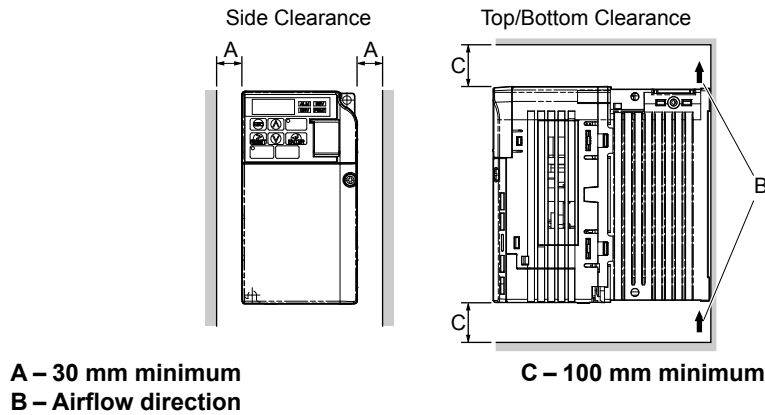


Figure 2.2 Correct Installation Spacing

**Note:** IP20/NEMA 1, UL Type 1 and IP66/NEMA 4X, UL Type 4X enclosure models require the same amount of space above and below the drive for installation.

### Multiple Drive Installation

When installing multiple drives into the same enclosure panel, mount the drives according to Figure 2.2. When mounting drives with a minimum side-by-side clearance of 2 mm according to Figure 2.3, derating must be considered and parameter L8-35 must be set.

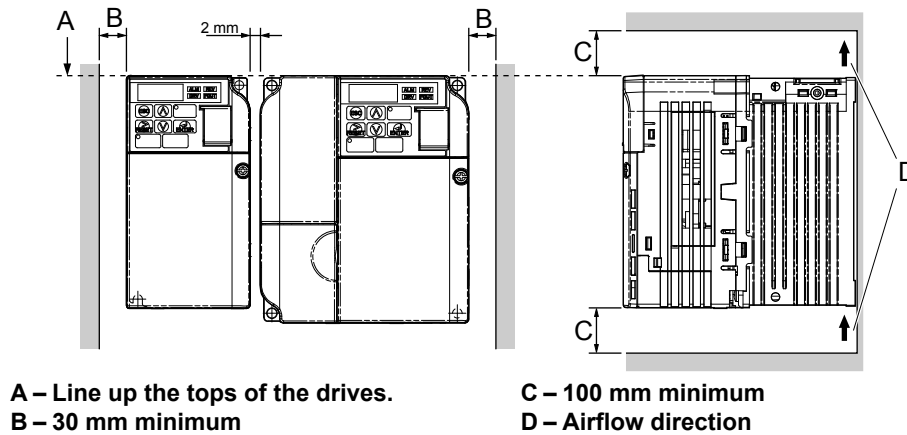


Figure 2.3 Space Between Drives (Side-by-Side Mounting)

**Note:** When installing drives of different heights in the same enclosure panel, the tops of the drives should line up. Leave space between the top and bottom of stacked drives for cooling fan replacement if required. Using this method, it is possible to replace the cooling fans later.

**NOTICE:** When mounting IP20/NEMA 1, UL Type 1 enclosure drives side by side, the top covers of all drives must be removed as shown in Figure 2.4.

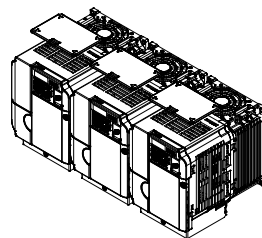


Figure 2.4 IP20/NEMA 1, UL Type 1 Side-by-Side Mounting in Enclosure

### ◆ Exterior and Mounting Dimensions

The installed 24 V power supply option adds 27 mm (1.06 in.) to the total depth of IP20/NEMA 1, UL Type 1 enclosure drives. Height and width dimensions are unaffected.

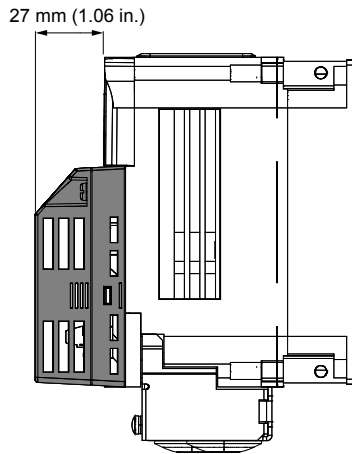


Figure 2.5 24 V Power Supply Dimensions

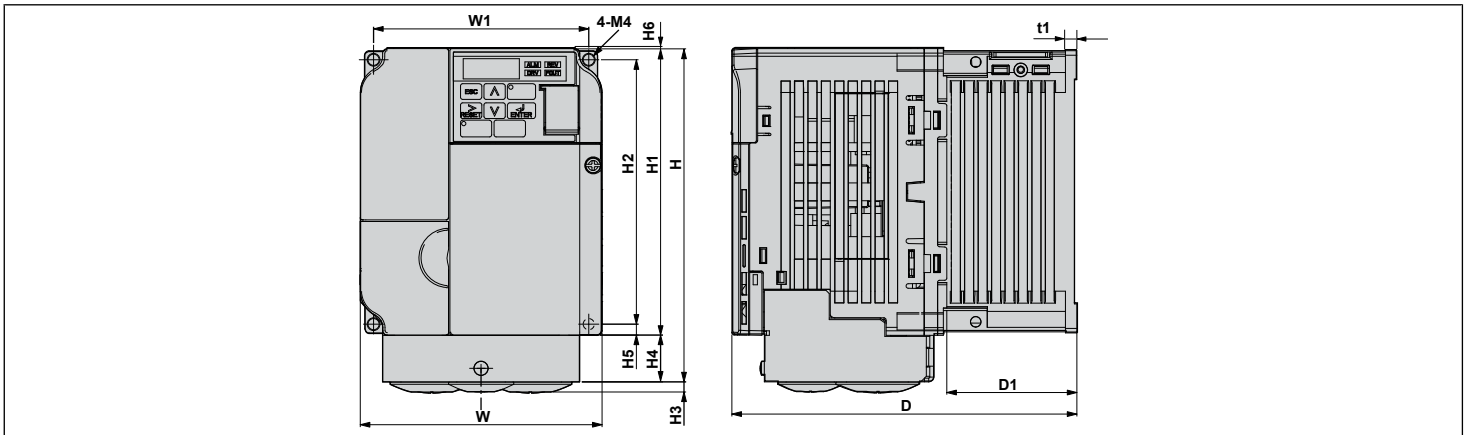
### ■ IP20/NEMA 1, UL Type 1 Enclosure Dimensions

Table 2.2 Dimensions for IP20/NEMA 1, UL Type 1 Enclosure Drives

| Voltage Class           | Drive Model | Dimensions mm (in) |              |            |           |            |            |          |           |          |            |             |          |              |
|-------------------------|-------------|--------------------|--------------|------------|-----------|------------|------------|----------|-----------|----------|------------|-------------|----------|--------------|
|                         |             | W                  | H            | D <1>      | W1        | H1         | H2         | H3       | H4        | H5       | H6         | D1          | t1       | Wt. kg (lb.) |
| Three-Phase 200 V Class | 2V0006F     | 68 (2.68)          | 149.5 (5.89) | 128 (5.04) | 56 (2.20) | 128 (5.03) | 118 (4.65) | 4 (0.16) | 20 (0.79) | 5 (0.20) | 1.5 (0.06) | 58.5 (2.32) | 5 (0.20) | 1.3 (2.9)    |

<1> The installed 24 V power supply option adds 27 mm (1.06 in.) to the total depth of the drive.

Table 2.3 Dimensions for IP20/NEMA 1, UL Type 1 Enclosure Drives

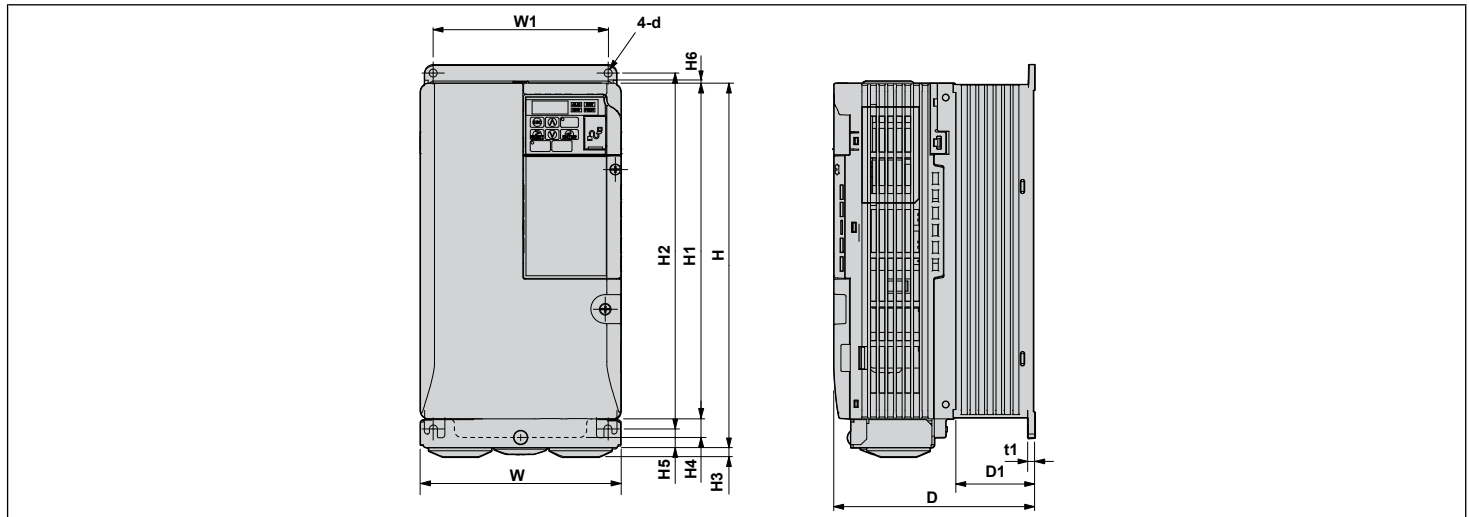


| Voltage Class               | Drive Model | Dimensions mm (in) |                 |                 |               |               |               |               |              |             |               |              |             |              |
|-----------------------------|-------------|--------------------|-----------------|-----------------|---------------|---------------|---------------|---------------|--------------|-------------|---------------|--------------|-------------|--------------|
|                             |             | W                  | H               | D <1>           | W1            | H1            | H2            | H3            | H4           | H5          | H6            | D1           | t1          | Wt. kg (lb.) |
| Single-Phase<br>200 V Class | BV0006F     | 108<br>(4.25)      | 149.5<br>(5.89) | 137.5<br>(5.41) | 96<br>(3.78)  | 128<br>(5.03) | 118<br>(4.65) | 4<br>(0.16)   | 20<br>(0.79) | 5<br>(0.20) | 1.5<br>(0.06) | 58<br>(2.28) | 5<br>(0.20) | 1.9<br>(4.2) |
|                             | BV0010F     | 108<br>(4.25)      | 149.5<br>(5.89) | 154<br>(6.06)   | 96<br>(3.78)  | 128<br>(5.03) | 118<br>(4.65) | 4<br>(0.16)   | 20<br>(0.79) | 5<br>(0.20) | 1.5<br>(0.06) | 58<br>(2.28) | 5<br>(0.20) | 2.0<br>(4.4) |
|                             | BV0012F     | 140<br>(5.51)      | 153<br>(6.02)   | 163<br>(6.42)   | 128<br>(5.04) | 128<br>(5.03) | 118<br>(4.65) | 4.8<br>(0.19) | 20<br>(0.79) | 5<br>(0.20) | 5<br>(0.20)   | 65<br>(2.56) | 5<br>(0.20) | 2.6<br>(5.7) |
|                             | BV0018F     | 170<br>(6.69)      | 171<br>(6.73)   | 180<br>(7.08)   | 158<br>(6.22) | 133<br>(5.23) | 118<br>(4.64) | 4.8<br>(0.19) | 38<br>(1.50) | 5<br>(0.20) | 5<br>(0.20)   | 65<br>(2.56) | 5<br>(0.20) | 3.3<br>(7.3) |
| Three-Phase<br>200 V Class  | 2V0010F     | 108<br>(4.25)      | 149.5<br>(5.89) | 129<br>(5.08)   | 96<br>(3.78)  | 128<br>(5.03) | 118<br>(4.65) | 4<br>(0.16)   | 20<br>(0.79) | 5<br>(0.20) | 1.5<br>(0.06) | 58<br>(2.28) | 5<br>(0.20) | 1.9<br>(4.2) |
|                             | 2V0012F     | 108<br>(4.25)      | 149.5<br>(5.89) | 137.5<br>(5.41) | 96<br>(3.78)  | 128<br>(5.03) | 118<br>(4.65) | 4<br>(0.16)   | 20<br>(0.79) | 5<br>(0.20) | 1.5<br>(0.06) | 58<br>(2.28) | 5<br>(0.20) | 1.9<br>(4.2) |
|                             | 2V0020F     | 140<br>(5.51)      | 153<br>(6.02)   | 143<br>(5.63)   | 128<br>(5.04) | 128<br>(5.03) | 118<br>(4.65) | 4.8<br>(0.19) | 20<br>(0.79) | 5<br>(0.20) | 5<br>(0.20)   | 65<br>(2.56) | 5<br>(0.20) | 2.6<br>(5.7) |
| Three-Phase<br>400 V Class  | 4V0002F     | 108<br>(4.25)      | 149.5<br>(5.89) | 99<br>(3.90)    | 96<br>(3.78)  | 128<br>(5.03) | 118<br>(4.65) | 4<br>(0.16)   | 20<br>(0.79) | 5<br>(0.20) | 1.5<br>(0.06) | 28<br>(1.10) | 5<br>(0.20) | 1.4<br>(3.1) |
|                             | 4V0004F     | 108<br>(4.25)      | 149.5<br>(5.89) | 137.5<br>(5.41) | 96<br>(3.78)  | 128<br>(5.03) | 118<br>(4.65) | 4<br>(0.16)   | 20<br>(0.79) | 5<br>(0.20) | 1.5<br>(0.06) | 58<br>(2.28) | 5<br>(0.20) | 1.9<br>(4.2) |
|                             | 4V0005F     | 108<br>(4.25)      | 149.5<br>(5.89) | 154<br>(6.06)   | 96<br>(3.78)  | 128<br>(5.03) | 118<br>(4.65) | 4<br>(0.16)   | 20<br>(0.79) | 5<br>(0.20) | 1.5<br>(0.06) | 58<br>(2.28) | 5<br>(0.20) | 1.9<br>(4.2) |
|                             | 4V0007F     | 108<br>(4.25)      | 149.5<br>(5.89) | 154<br>(6.06)   | 96<br>(3.78)  | 128<br>(5.03) | 118<br>(4.65) | 4<br>(0.16)   | 20<br>(0.79) | 5<br>(0.20) | 1.5<br>(0.06) | 58<br>(2.28) | 5<br>(0.20) | 1.9<br>(4.2) |
|                             | 4V0009F     | 108<br>(4.25)      | 149.5<br>(5.89) | 154<br>(6.06)   | 96<br>(3.78)  | 128<br>(5.03) | 118<br>(4.65) | 4<br>(0.16)   | 20<br>(0.79) | 5<br>(0.20) | 1.5<br>(0.06) | 58<br>(2.28) | 5<br>(0.20) | 1.9<br>(4.2) |
|                             | 4V0011F     | 140<br>(5.51)      | 153<br>(6.02)   | 143<br>(5.63)   | 128<br>(5.04) | 128<br>(5.03) | 118<br>(4.65) | 4.8<br>(0.19) | 20<br>(0.79) | 5<br>(0.20) | 5<br>(0.20)   | 65<br>(2.56) | 5<br>(0.20) | 2.6<br>(5.7) |

<1> The installed 24 V power supply option adds 27 mm (1.06 in.) to the total depth of the drive.

## 2.2 Mechanical Installation

Table 2.4 Dimensions for IP20/NEMA 1, UL Type 1 Enclosure Drives



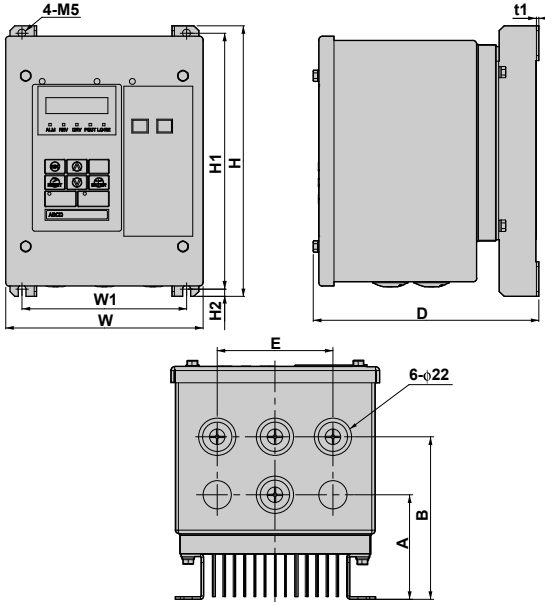
| Voltage Class            | Drive Model | Dimensions mm (in) |             |            |            |             |             |          |           |           |            |           |          |    |              |
|--------------------------|-------------|--------------------|-------------|------------|------------|-------------|-------------|----------|-----------|-----------|------------|-----------|----------|----|--------------|
|                          |             | W                  | H           | D <1>      | W1         | H1          | H2          | H3       | H4        | H5        | H6         | D1        | t1       | d  | Wt. kg (lb.) |
| Single-Phase 200 V Class | 2V0030F     | 140 (5.51)         | 254 (10.00) | 140 (5.51) | 122 (4.80) | 234 (9.21)  | 248 (9.76)  | 6 (0.24) | 13 (0.51) | 13 (0.51) | 1.5 (0.06) | 55 (2.17) | 5 (0.20) | M5 | 3.8 (8.4)    |
|                          | 2V0040F     | 140 (5.51)         | 254 (10.00) | 140 (5.51) | 122 (4.80) | 234 (9.21)  | 248 (9.76)  | 6 (0.24) | 13 (0.51) | 13 (0.51) | 1.5 (0.06) | 55 (2.17) | 5 (0.20) | M5 | 3.8 (8.4)    |
|                          | 2V0056F     | 180 (7.09)         | 290 (11.42) | 163 (6.42) | 160 (6.30) | 270 (10.63) | 284 (11.18) | 6 (0.24) | 15 (0.59) | 13 (0.51) | 1.5 (0.06) | 75 (2.95) | 5 (0.20) | M5 | 5.5 (12.1)   |
|                          | 2V0069F     | 220 (8.66)         | 350 (13.78) | 187 (7.36) | 192 (7.56) | 320 (12.60) | 336 (13.23) | 7 (0.28) | 15 (0.59) | 22 (0.87) | 1.5 (0.06) | 78 (3.07) | 5 (0.20) | M6 | 9.2 (20.3)   |
| Three-Phase 200 V Class  | 4V0018F     | 140 (5.51)         | 254 (10.00) | 140 (5.51) | 122 (4.80) | 234 (9.21)  | 248 (9.76)  | 6 (0.24) | 13 (0.51) | 13 (0.51) | 1.5 (0.06) | 55 (2.17) | 5 (0.20) | M5 | 3.8 (8.4)    |
|                          | 4V0023F     | 140 (5.51)         | 254 (10.00) | 140 (5.51) | 122 (4.80) | 234 (9.21)  | 248 (9.76)  | 6 (0.24) | 13 (0.51) | 13 (0.51) | 1.5 (0.06) | 55 (2.17) | 5 (0.20) | M5 | 3.8 (8.4)    |
|                          | 4V0031F     | 180 (7.09)         | 290 (11.42) | 143 (5.63) | 160 (6.30) | 270 (10.63) | 284 (11.18) | 6 (0.24) | 15 (0.59) | 13 (0.51) | 1.5 (0.06) | 55 (2.17) | 5 (0.20) | M5 | 5.2 (11.5)   |
| Three-Phase 400 V Class  | 4V0038F     | 180 (7.09)         | 290 (11.42) | 163 (6.42) | 160 (6.30) | 270 (10.63) | 284 (11.18) | 6 (0.24) | 13 (0.51) | 13 (0.51) | 1.5 (0.06) | 75 (2.95) | 5 (0.20) | M5 | 5.5 (12.1)   |

<1> The installed 24 V power supply option adds 27 mm (1.06 in.) to the total depth of the drive.



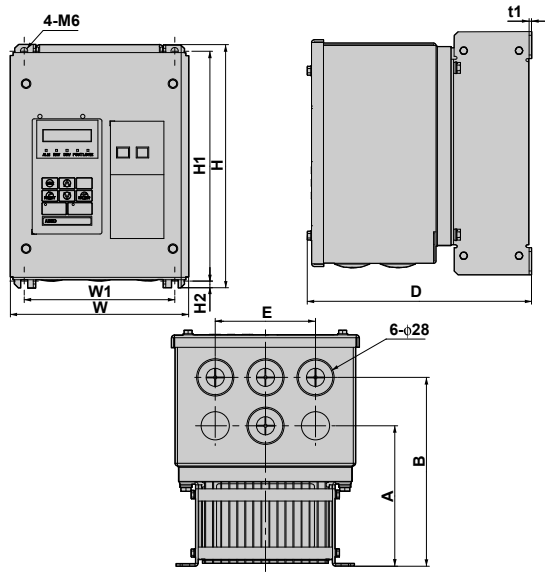
■ IP66/NEMA 4X, UL Type 4X Enclosure Dimensions

Table 2.5 Dimensions for IP66/NEMA 4X, UL Type 4X Enclosure Drives



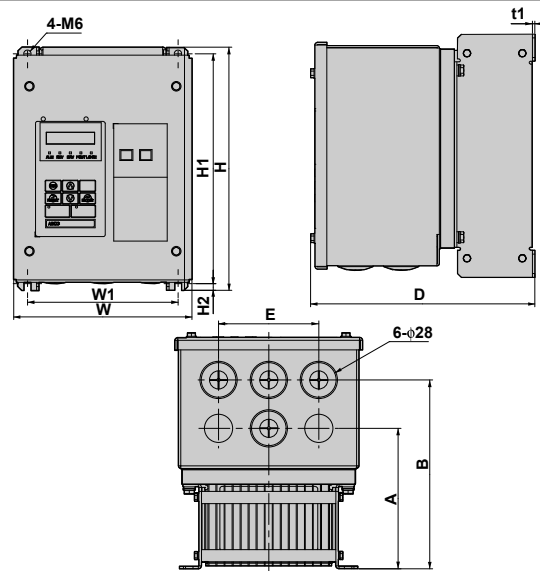
| Voltage Class              | Drive Model | Dimensions mm (in) |               |               |               |               |             |             |              |               |              |                |
|----------------------------|-------------|--------------------|---------------|---------------|---------------|---------------|-------------|-------------|--------------|---------------|--------------|----------------|
|                            |             | W                  | H             | D             | W1            | H1            | H2          | t1          | A            | B             | E            | Wt. kg (lb.)   |
| Three-Phase<br>200 V Class | 2V0006G     | 162<br>(6.38)      | 222<br>(8.74) | 185<br>(7.28) | 135<br>(5.32) | 210<br>(8.27) | 6<br>(0.24) | 2<br>(0.08) | 81<br>(3.19) | 126<br>(4.96) | 90<br>(3.54) | 4.8<br>(10.58) |
| Three-Phase<br>400 V Class | 4V0002G     | 162<br>(6.38)      | 222<br>(8.74) | 185<br>(7.28) | 135<br>(5.32) | 210<br>(8.27) | 6<br>(0.24) | 2<br>(0.08) | 81<br>(3.19) | 126<br>(4.96) | 90<br>(3.54) | 5.0<br>(11.02) |
|                            | 4V0004G     |                    |               |               |               |               |             |             |              |               |              | 5.1<br>(11.24) |

Table 2.6 Dimensions for IP66/NEMA 4X, UL Type 4X Enclosure Drives



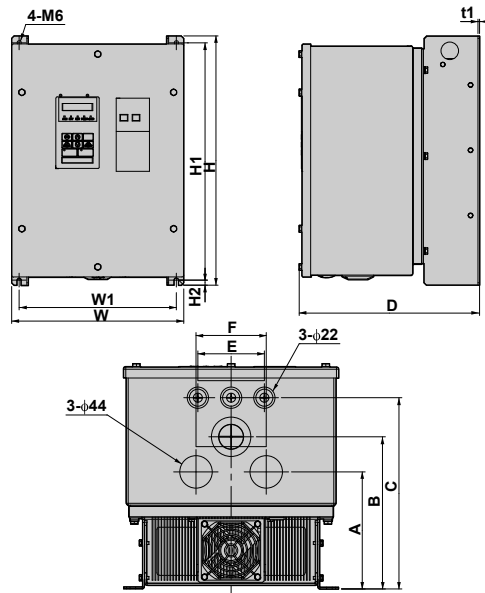
| Voltage Class               | Drive Model | Dimensions mm (in) |                |               |               |               |             |               |               |               |               |                |
|-----------------------------|-------------|--------------------|----------------|---------------|---------------|---------------|-------------|---------------|---------------|---------------|---------------|----------------|
|                             |             | W                  | H              | D             | W1            | H1            | H2          | t1            | A             | B             | E             | Wt. kg (lb.)   |
| Single-Phase<br>200 V Class | BV0006G     | 187<br>(7.36)      | 255<br>(10.04) | 235<br>(9.25) | 158<br>(6.22) | 241<br>(9.49) | 7<br>(0.28) | 2.5<br>(0.10) | 140<br>(5.51) | 188<br>(7.40) | 100<br>(3.94) | 7.8<br>(17.2)  |
|                             | BV0010G     |                    |                |               |               |               |             |               |               |               |               | 8.2<br>(18.08) |
|                             | BV0012G     |                    |                |               |               |               |             |               |               |               |               |                |

## 2.2 Mechanical Installation



| Voltage Class              | Drive Model | Dimensions mm (in) |                |               |               |               |             |               |               |               |               | Wt.<br>kg (lb.) |
|----------------------------|-------------|--------------------|----------------|---------------|---------------|---------------|-------------|---------------|---------------|---------------|---------------|-----------------|
|                            |             | W                  | H              | D             | W1            | H1            | H2          | t1            | A             | B             | E             |                 |
| Three-Phase<br>200 V Class | 2V0010G     | 187<br>(7.36)      | 255<br>(10.04) | 235<br>(9.25) | 158<br>(6.22) | 241<br>(9.49) | 7<br>(0.28) | 2.5<br>(0.10) | 140<br>(5.51) | 188<br>(7.40) | 100<br>(3.94) | 7.7<br>(16.98)  |
|                            | 2V0012G     |                    |                |               |               |               |             |               |               |               |               | 8.1<br>(17.86)  |
|                            | 2V0020G     |                    |                |               |               |               |             |               |               |               |               | 8.1<br>(17.86)  |
| Three-Phase<br>400 V Class | 4V0005G     | 187<br>(7.36)      | 255<br>(10.04) | 235<br>(9.25) | 158<br>(6.22) | 241<br>(9.49) | 7<br>(0.28) | 2.5<br>(0.10) | 140<br>(5.51) | 188<br>(7.40) | 100<br>(3.94) | 7.7<br>(16.98)  |
|                            | 4V0007G     |                    |                |               |               |               |             |               |               |               |               | 7.9<br>(17.42)  |
|                            | 4V0009G     |                    |                |               |               |               |             |               |               |               |               | 7.9<br>(17.42)  |
|                            | 4V0011G     |                    |                |               |               |               |             |               |               |               |               | 8.1<br>(17.86)  |

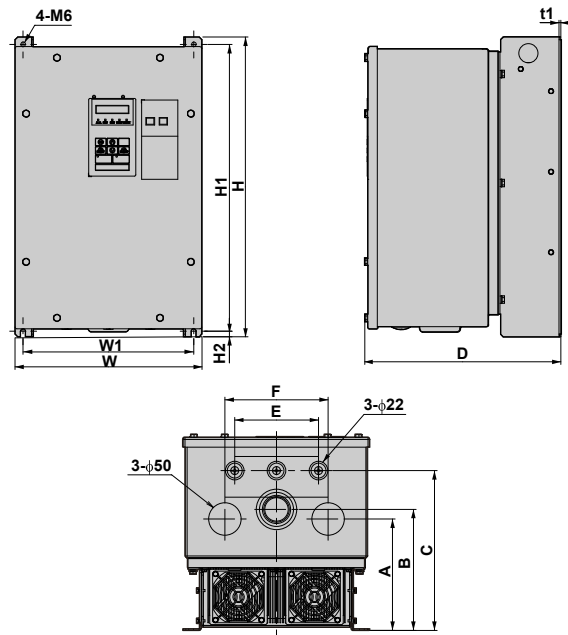
Table 2.7 Dimensions for IP66/NEMA 4X, UL Type 4X Enclosure Drives



| Voltage Class              | Drive Model | Dimensions mm (in) |                |                |                |                |               |               |               |                 |                |              |              | Wt. kg (lb.)    |
|----------------------------|-------------|--------------------|----------------|----------------|----------------|----------------|---------------|---------------|---------------|-----------------|----------------|--------------|--------------|-----------------|
|                            |             | W                  | H              | D              | W1             | H1             | H2            | t1            | A             | B               | C              | E            | F            |                 |
| Three-Phase<br>200 V Class | 2V0030G     | 290<br>(11.42)     | 420<br>(16.54) | 305<br>(12.01) | 265<br>(10.43) | 400<br>(15.75) | 8.5<br>(0.33) | 2.5<br>(0.10) | 158<br>(6.22) | 205.5<br>(8.09) | 258<br>(10.16) | 90<br>(3.54) | 95<br>(3.74) | 21.8<br>(48.06) |
|                            | 2V0040G     |                    |                |                |                |                |               |               |               |                 |                |              |              | 23.2<br>(51.15) |
|                            | 2V0056G     |                    |                |                |                |                |               |               |               |                 |                |              |              | 23.2<br>(51.15) |
| Three-Phase<br>400 V Class | 4V0018G     | 290<br>(11.42)     | 420<br>(16.54) | 305<br>(12.01) | 265<br>(10.43) | 400<br>(15.75) | 8.5<br>(0.33) | 2.5<br>(0.10) | 158<br>(6.22) | 205.5<br>(8.09) | 258<br>(10.16) | 90<br>(3.54) | 95<br>(3.74) | 21.7<br>(47.84) |
|                            | 4V0023G     |                    |                |                |                |                |               |               |               |                 |                |              |              | 21.8<br>(48.06) |
|                            | 4V0031G     |                    |                |                |                |                |               |               |               |                 |                |              |              | 22.9<br>(50.49) |
|                            | 4V0038G     |                    |                |                |                |                |               |               |               |                 |                |              |              | 23.2<br>(51.15) |

## 2.2 Mechanical Installation

Table 2.8 Dimensions for IP66/NEMA 4X, UL Type 4X Enclosure Drives



| Voltage Class              | Drive Model | Dimensions mm (in) |                |                |                |                |               |               |               |               |               |               |               | Wt.<br>kg (lb.) |
|----------------------------|-------------|--------------------|----------------|----------------|----------------|----------------|---------------|---------------|---------------|---------------|---------------|---------------|---------------|-----------------|
|                            |             | W                  | H              | D              | W1             | H1             | H2            | t1            | A             | B             | C             | E             | F             |                 |
| Three-Phase<br>200 V Class | 2V0069G     | 290<br>(11.42)     | 465<br>(18.31) | 305<br>(12.01) | 265<br>(10.43) | 445<br>(17.52) | 8.5<br>(0.33) | 2.5<br>(0.10) | 173<br>(6.81) | 188<br>(7.40) | 248<br>(9.76) | 130<br>(5.12) | 160<br>(6.30) | 27.7<br>(61.07) |

# Electrical Installation

---

This chapter explains proper procedures for wiring the control circuit terminals, motor and power supply.

|             |  |           |
|-------------|--|-----------|
| <b>3.1</b>  | <b>SECTION SAFETY.....</b>   | <b>38</b> |
| <b>3.2</b>  | <b>STANDARD CONNECTION DIAGRAM.....</b>  | <b>40</b> |
| <b>3.3</b>  | <b>TERMINAL BLOCK CONFIGURATION.....</b>                                       | <b>44</b> |
| <b>3.4</b>  | <b>PROTECTIVE COVERS.....</b>  | <b>45</b> |
| <b>3.5</b>  | <b>PREPARING IP66/NEMA 4X, UL TYPE 4X ENCLOSURE DRIVES FOR<br/>WIRING.....</b> | <b>47</b> |
| <b>3.6</b>  | <b>MAIN CIRCUIT WIRING.....</b>  | <b>50</b> |
| <b>3.7</b>  | <b>CONTROL CIRCUIT WIRING.....</b>   | <b>55</b> |
| <b>3.8</b>  | <b>I/O CONNECTIONS.....</b>  | <b>59</b> |
| <b>3.9</b>  | <b>MAIN FREQUENCY REFERENCE.....</b>   | <b>61</b> |
| <b>3.10</b> | <b>WIRING CHECKLIST.....</b>   | <b>62</b> |

## 3.1 Section Safety

### DANGER

#### Electrical Shock Hazard

**Do not connect or disconnect wiring while the power is on.**

Failure to comply will result in death or serious injury.

### WARNING

#### Electrical Shock Hazard

**Do not operate equipment with covers removed.**

Failure to comply could result in death or serious injury.

The diagrams in this section may show drives without covers or safety shields to show details. Be sure to reinstall covers or shields before operating the drives and run the drives according to the instructions described in this manual.

**Always ground the motor-side grounding terminal.**

Improper equipment grounding could result in death or serious injury by contacting the motor case.

**Do not perform work on the drive while wearing loose clothing, jewelry or without eye protection.**

Failure to comply could result in death or serious injury.

Remove all metal objects such as watches and rings, secure loose clothing, and wear eye protection before beginning work on the drive.

**Do not remove covers or touch circuit boards while the power is on.**

Failure to comply could result in death or serious injury.

**Do not allow unqualified personnel to perform work on the drive.**

Failure to comply could result in death or serious injury.

Installation, maintenance, inspection, and servicing must be performed only by authorized personnel familiar with installation, adjustment, and maintenance of AC drives.

**Do not touch any terminals before the capacitors have fully discharged.**

Failure to comply could result in death or serious injury.

Before wiring terminals, disconnect all power to the equipment. The internal capacitor remains charged even after the power supply is turned off. The charge indicator LED will extinguish when the DC bus voltage is below 50 Vdc. To prevent electric shock, wait at least five minutes after all indicators are off and measure the DC bus voltage level to confirm safe level.

#### Fire Hazard

**Tighten all terminal screws to the specified tightening torque.**

Loose electrical connections could result in death or serious injury by fire due to overheating of electrical connections.

**Do not use improper combustible materials.**

Failure to comply could result in death or serious injury by fire.

Attach the drive to metal or other noncombustible material.

**Do not use an improper voltage source.**

Failure to comply could result in death or serious injury by fire.

Verify that the rated voltage of the drive matches the voltage of the incoming power supply before applying power.

**Always use a thermal overload relay or an over-temperature contact when using a braking resistor.**

Failure to comply could result in death or serious injury by fire.

Power to the drive should be interrupted when the relay is triggered.

**NOTICE**

**Observe proper electrostatic discharge procedures (ESD) when handling the drive and circuit boards.**

Failure to comply may result in ESD damage to the drive circuitry.

**Never connect or disconnect the motor from the drive while the drive is outputting voltage.**

Improper equipment sequencing could result in damage to the drive.

**Do not use unshielded cable for control wiring.**

Failure to comply may cause electrical interference resulting in poor system performance. Use shielded, twisted-pair wires and ground the shield to the ground terminal of the drive.

**Check all the wiring to ensure that all connections are correct after installing the drive and connecting any other devices.**

Failure to comply could result in damage to the drive.

**Do not modify the drive circuitry.**

Failure to comply could result in damage to the drive and will void warranty.

Yaskawa is not responsible for any modification of the product made by the user. This product must not be modified.

**Route motor leads U/T1, V/T2, and W/T3 separate from other leads to reduce possible interference-related issues.**

Failure to comply may result in abnormal operation of drive and nearby equipment.

### 3.2 Standard Connection Diagram

Connect the drive and peripheral devices as shown in [Figure 3.1](#). It is possible to run the drive via the digital operator without connecting digital I/O wiring. This section does not discuss drive operation; [Refer to Start-Up Programming & Operation on page 63](#) for instructions on operating the drive.

**NOTICE:** *Inadequate branch short circuit protection could result in damage to the drive. Install adequate branch circuit short circuit protection per applicable codes. The drive is suitable for circuits capable of delivering not more than 31,000 RMS symmetrical amperes, 240 Vac maximum (200 V Class) and 480 Vac maximum (400 V Class).*

**NOTICE:** *When the wiring distance is greater than 100 meters, pay special attention to the motor insulation voltage or use a drive duty motor. Failure to comply could lead to motor insulation breakdown.*

**NOTICE:** *Correctly set Sink/Source jumper S3 for internal power supply. Failure to comply may result in damage to the drive. [Refer to I/O Connections on page 59](#) for details.*

**NOTICE:** *Do not connect AC control circuit ground to drive enclosure. Improper drive grounding can cause control circuit malfunction.*

**NOTICE:** *Route motor leads U/T1, V/T2, and W/T3 separate from all other leads to reduce possible interference related issues. Failure to comply may result in abnormal operation of drive and nearby equipment.*

**NOTICE:** *The minimum load for the multi-function relay output MA-MB-MC is 10 mA. If a circuit requires less than 10 mA (reference value), connect it to a photocoupler output (P1, P2, PC). Improper application of peripheral devices could result in damage to the photocoupler output of the drive.*



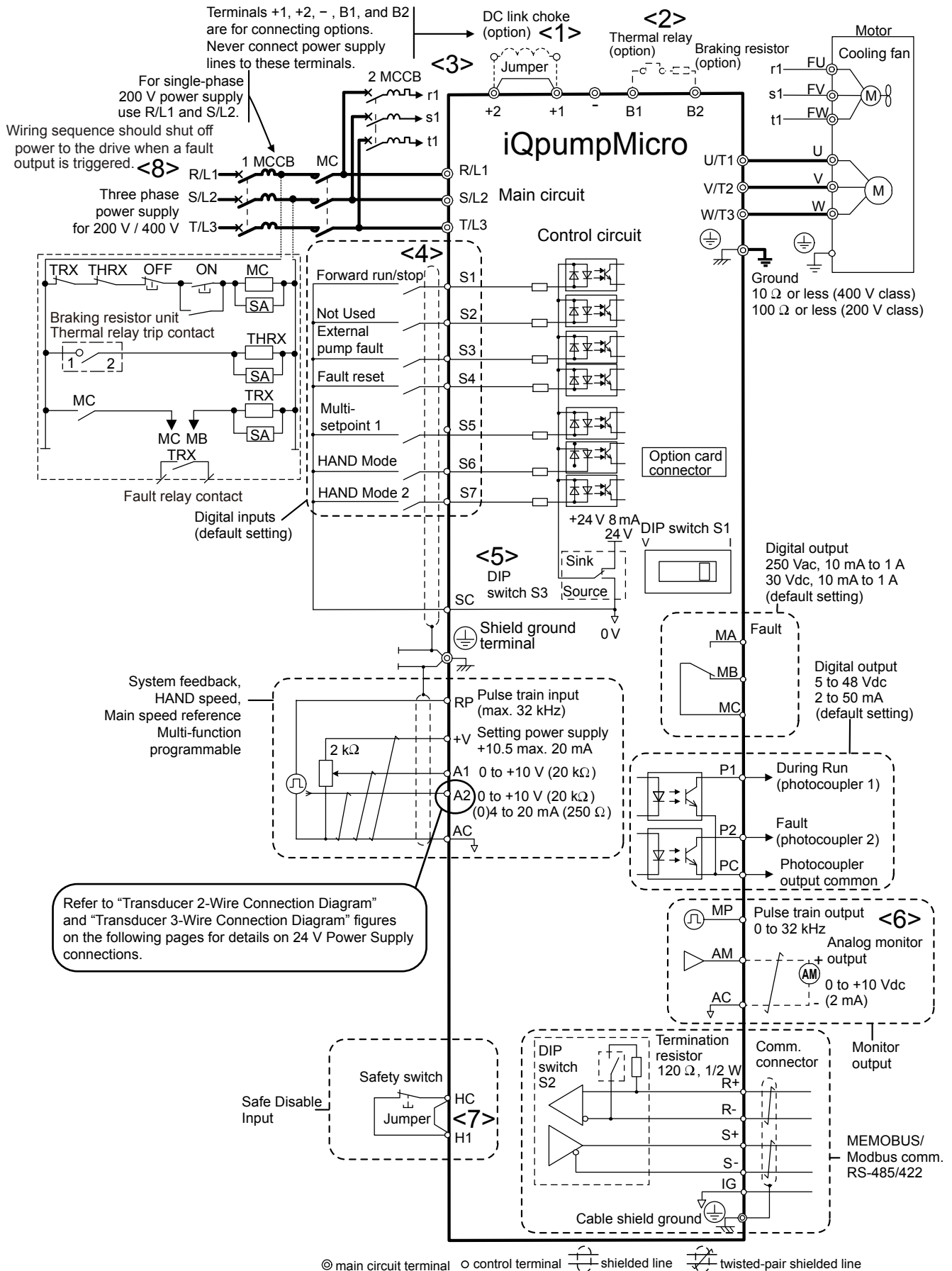


Figure 3.1 Drive Standard Connection Diagram

## 3.2 Standard Connection Diagram

- <1> Remove the jumper when installing an optional DC link choke.
- <2> The MC on the input side of the main circuit should open when the thermal relay is triggered.
- <3> Self-cooled motors do not require separate cooling fan motor wiring.
- <4> Connected using sequence input signal (S1 to S7) from NPN transistor; Default: sink mode (0 V com).
- <5> Use only a +24 V internal power supply in sinking mode; the source mode requires an external power supply.
- <6> Monitor outputs work with devices such as analog frequency meters, ammeters, voltmeters and wattmeters; they are not intended for use as a feedback-type of signal.
- <7> Disconnect the wire jumper between HC and H1 when utilizing the safety input. *Refer to Wiring the Control Circuit Terminal on page 57* for details on removing the jumper. The wire length for the Safe Disable input should not exceed 30 m.
- <8> Note that if the drive is set to trigger a fault output whenever the fault restart function is activated (L5-02 = 1), then a sequence to interrupt power when a fault occurs will result in shutting off the power to the drive as the drive attempts to restart itself. The default setting for L5-02 is 0 (fault output active during restart attempt).

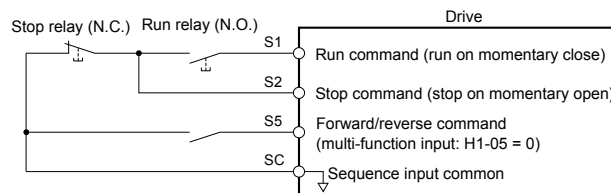
**WARNING! Sudden Movement Hazard.** Do not close the wiring for the control circuit unless the multifunction input terminal parameter is properly set (S5 for 3-Wire; H1-05 = "0"). Improper sequencing of run/stop circuitry could result in death or serious injury from moving equipment.

**WARNING! Sudden Movement Hazard.** Ensure start/stop and safety circuits are wired properly and in the correct state before energizing the drive. Failure to comply could result in death or serious injury from moving equipment. When programmed for 3-Wire control, a momentary closure on terminal S1 may cause the drive to start.

**WARNING! When 3-Wire sequence is used, set the drive to 3-Wire sequence before wiring the control terminals and ensure parameter b1-17 is set to 0 (drive does not accept a run command at power up (default)). If the drive is wired for 3-Wire sequence but set up for 2-Wire sequence (default) and if parameter b1-17 is set to 1 (drive accepts a Run command at power up), the motor will rotate in reverse direction at power up of the drive and may cause injury.**

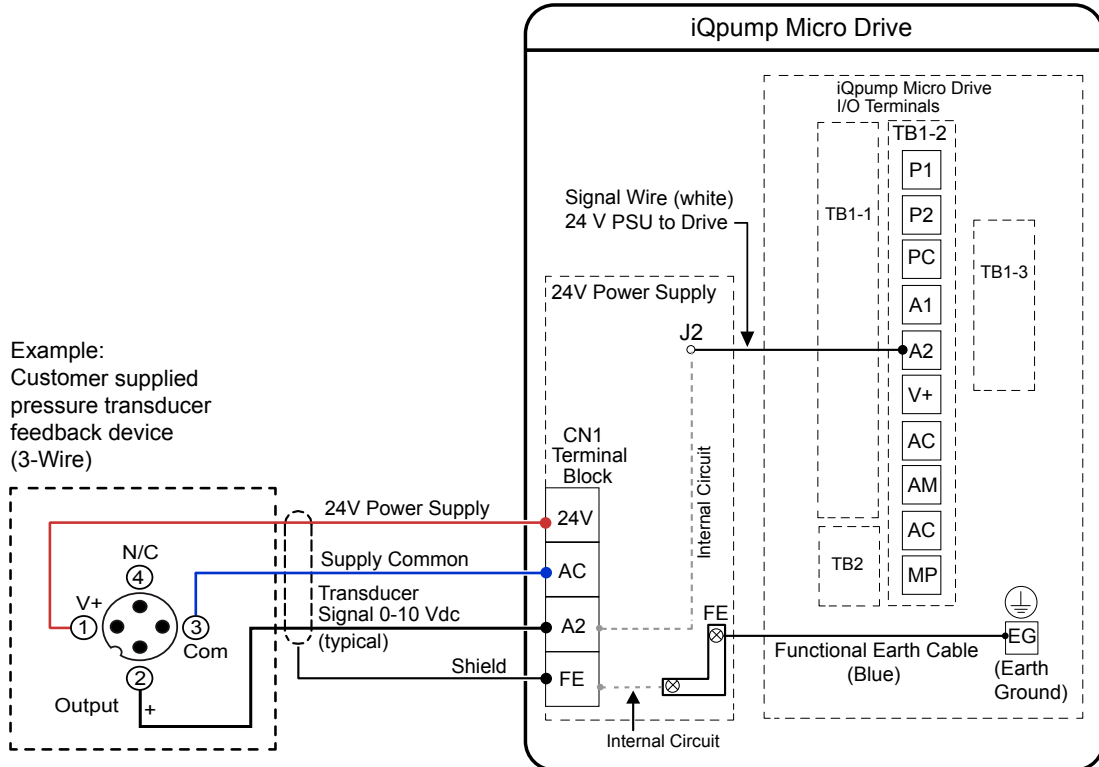
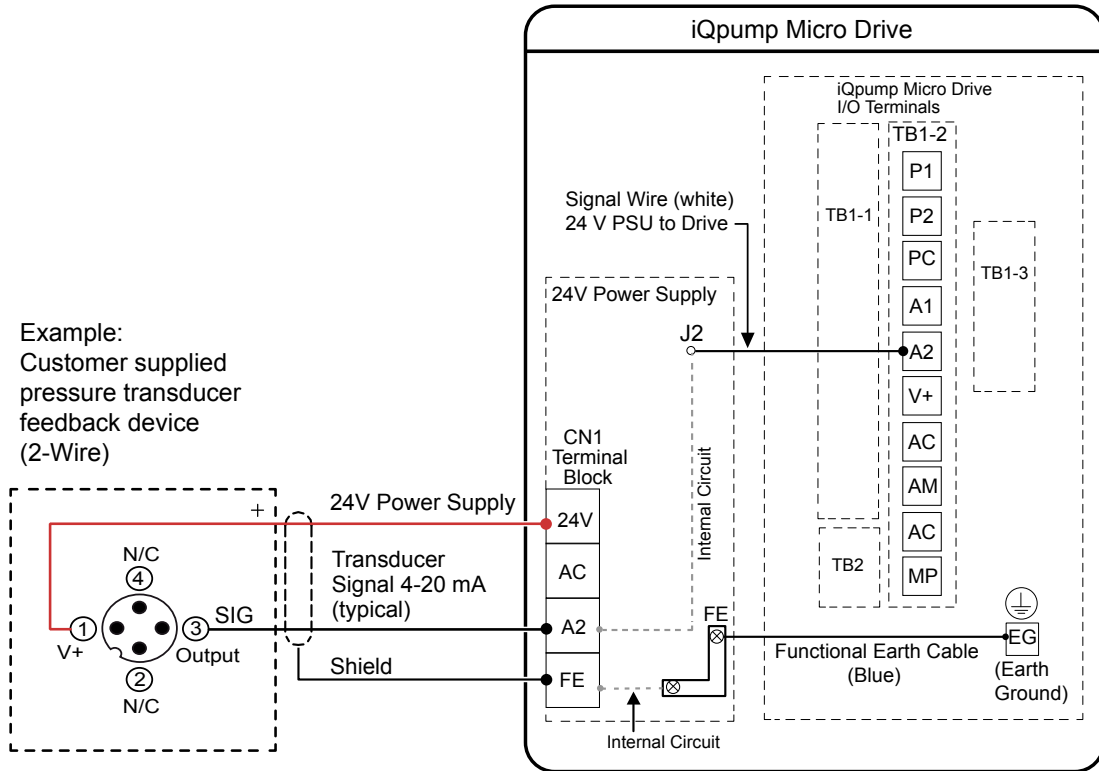
**WARNING! When the application preset function is executed (or A1-06 is set to any value other than 0) the drive I/O terminal functions change. This may cause unexpected operation and potential damage to equipment or injury.**

*Figure 3.2* illustrates an example of a 3-Wire sequence.



**Figure 3.2 3-Wire Sequence**

◆ Transducer Connection Diagrams



## 3.3 Terminal Block Configuration

Figure 3.5 provides illustrations of the main circuit terminal block configurations of the different drive sizes.

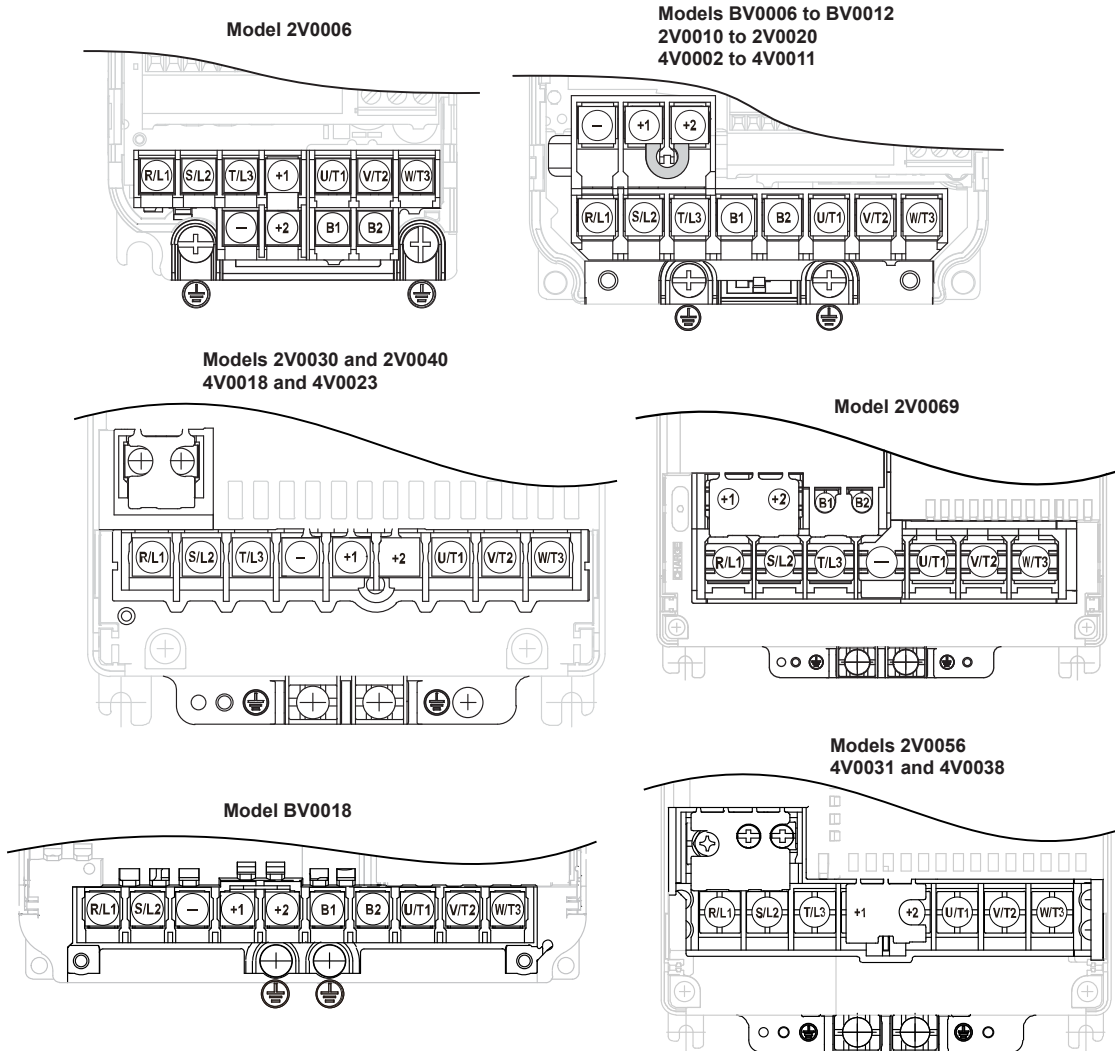


Figure 3.5 Main Circuit Terminal Block Configurations

## 3.4 Protective Covers

Follow the procedure below to remove the protective covers before wiring the drive and to reattach the covers after wiring is complete.

### ◆ IP20/NEMA 1, UL Type 1 Front and Bottom Cover Removal and Installation

#### ■ Removing the Protective Covers on an IP20/NEMA 1, UL Type 1 Design

1. Loosen the screw on the front cover to remove the front cover.

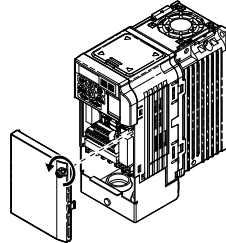
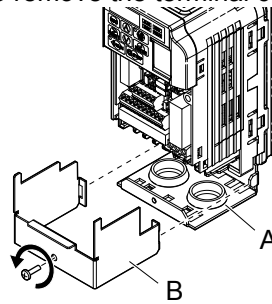


Figure 3.6 Remove the Front Cover on an IP20/NEMA 1, UL Type 1 Drive

2. Loosen the screw on the terminal cover to remove the terminal cover and expose the conduit bracket.

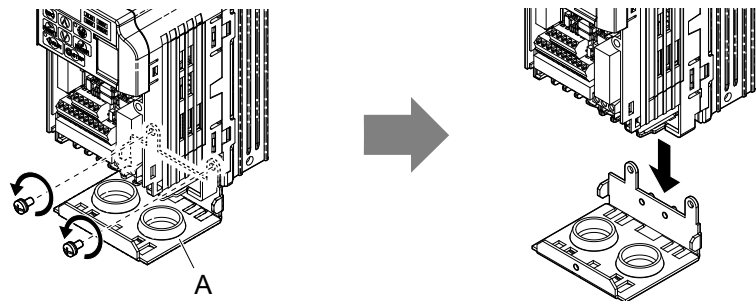


A – Conduit bracket

B – Terminal cover

Figure 3.7 Remove the Terminal Cover on an IP20/NEMA 1, UL Type 1 Drive

3. Loosen two screws attaching the conduit bracket to remove.



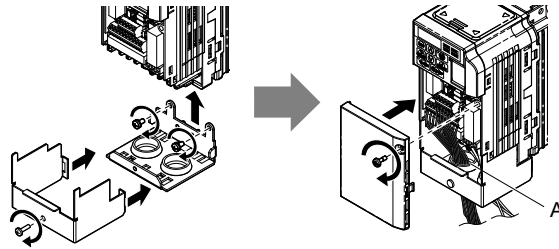
A –Conduit bracket

Figure 3.8 Remove the Conduit Bracket on an IP20/NEMA 1, UL Type 1 Drive

## 3.4 Protective Covers

### ■ Reattaching the Protective Covers

Pass power wiring and control signal wiring through the exit holes on the bottom of the conduit bracket of the drive. Place power wiring and control signal wiring in separate conduits. Properly connect all wiring after installing the drive and connecting other devices. Reattach all protective covers when wiring is complete.



**A** –Pass power wiring and control signal wiring through different exit holes at the bottom of the drive.

Figure 3.9 Reattach the Protective Covers and Conduit Bracket on an IP20/NEMA 1, UL Type 1 Drive

### ◆ IP20/NEMA 1, UL Type 1 Top Cover Removal and Installation

To improve the ambient temperature rating of a NEMA 1, UL Type 1 drive from 40 °C to 50 °C or to mount NEMA 1, UL Type 1 drives side-by-side, the top cover can be removed. Remove the top cover and set L8-35 to 2.

**Note:** Removing the top cover of a NEMA 1, UL Type 1 drive converts the drive to an IP20/Open-Chassis rating, and the drive will no longer have a NEMA 1, UL Type 1 rating.

### ■ Removing the Top Cover

Insert the blade of a straight-edge screwdriver into the opening of the top cover. Gently lift up on the front cover as indicated by the arrow in [Figure 3.10](#) to remove it from the drive.

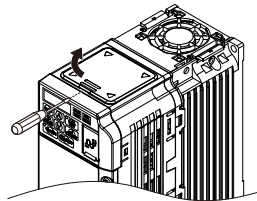


Figure 3.10 Removing the Top Cover

### ■ Reattaching the Top Cover

Align the connection tabs on the underside of the top cover with the connection tabs on the drive. Pinch in on the top cover to click the cover into place on the drive.

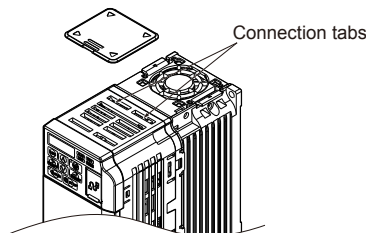


Figure 3.11 Reattaching the Top Cover

## 3.5 Preparing IP66/NEMA 4X, UL Type 4X Enclosure Drives for Wiring

### ◆ Select Cable Gland

Specific cable glands and gland plate covers are not listed for North America. [Table 3.1](#) lists the enclosure conduit hole dimensions by drive model. Use this table to select cable glands or gland plate covers from a local supplier. Use UL approved cable glands or gland cover plates with NEMA 4X, UL Type 4X, or IP66 integrity for all drive conduit holes. Cable glands or gland plate covers are supplied by the customer.

Table 3.1 Conduit Hole Dimensions

| Voltage Class               | Model   | Main Circuit                  |              |              | Number of Holes | Control Circuit       |             |
|-----------------------------|---------|-------------------------------|--------------|--------------|-----------------|-----------------------|-------------|
|                             |         | Conduit Hole Diameter mm (in) |              |              |                 | Hole Diameter mm (in) | Total Holes |
|                             |         | Input Holes                   | Output Holes | Option Holes |                 |                       |             |
| Single-Phase<br>200 V Class | BV0006G | 28 (1.10)                     | 28 (1.10)    | 28 (1.10)    | 1               | 22 (0.87)             | 3           |
|                             | BV0010G |                               |              |              |                 |                       |             |
|                             | BV0012G |                               |              |              |                 |                       |             |
| Three-Phase<br>200 V Class  | 2V0006G | 28 (1.10)                     | 28 (1.10)    | 28 (1.10)    | 1               | 22 (0.87)             | 3           |
|                             | 2V0010G |                               |              |              |                 |                       |             |
|                             | 2V0012G |                               |              |              |                 |                       |             |
|                             | 2V0020G |                               |              |              |                 |                       |             |
|                             | 2V0030G |                               |              |              |                 |                       |             |
|                             | 2V0040G |                               |              |              |                 |                       |             |
|                             | 2V0056G |                               |              |              |                 |                       |             |
|                             | 2V0069G |                               |              |              |                 |                       |             |
| Three-Phase<br>400 V Class  | 4V0002  | 28 (1.10)                     | 28 (1.10)    | 28 (1.10)    | 1               | 22 (0.87)             | 3           |
|                             | 4V0004  |                               |              |              |                 |                       |             |
|                             | 4V0005  |                               |              |              |                 |                       |             |
|                             | 4V0007  |                               |              |              |                 |                       |             |
|                             | 4V0009  |                               |              |              |                 |                       |             |
|                             | 4V0011  |                               |              |              |                 |                       |             |
|                             | 4V0018  |                               |              |              |                 |                       |             |
|                             | 4V0023  |                               |              |              |                 |                       |             |
|                             | 4V0031  |                               |              |              |                 |                       |             |
|                             | 4V0038  |                               |              |              |                 |                       |             |

### ■ Remove Rubber Bushings and Insert Cable Glands

**NOTICE:** Do not pinch or damage the sealing gasket when attaching the front cover. Damage to the gasket may allow moisture or dust to enter the protective enclosure and damage drive components.

**NOTICE:** Do not use silicone sealant with cable glands or front cover to reinforce waterproofing. Corrosive vapors produced by the sealant can damage circuit boards and compromise the watertight integrity of the protective enclosure.

**NOTICE:** Use only the recommended multi conductor cable and use only one cable per cable gland. Attempting to pass more than one wire through a cable gland create a space between wires that reduces the waterproofing and dustproofing capabilities of the cable gland, and may damage the drive.

**NOTICE:** Properly seal the rubber gasket along the outside of the cable gland. Improper seals may allow water or oil into the drive and damage components.

Remove the rubber bushings and insert the proper cable glands into the holes and tighten the glands with the locknut.

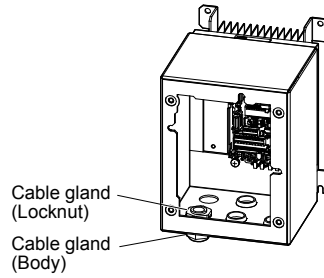


Figure 3.12 Inserting the Cable Glands

#### Route Cables Through Cable Glands

Route the cables through the cable glands then tighten the cable gland caps to complete preparation for main circuit and control circuit wiring.

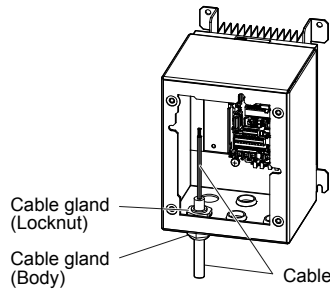


Figure 3.13 Cable Routing

#### IP66/NEMA 4X, UL Type 4X Enclosure Front Cover Removal and Installation

**NOTICE:** Do not attempt to disassemble the protective enclosure surrounding the drive. The protective enclosure is constructed as a single piece to include the heatsink. Attempting to disassemble the enclosure may void the protective integrity of the enclosure.

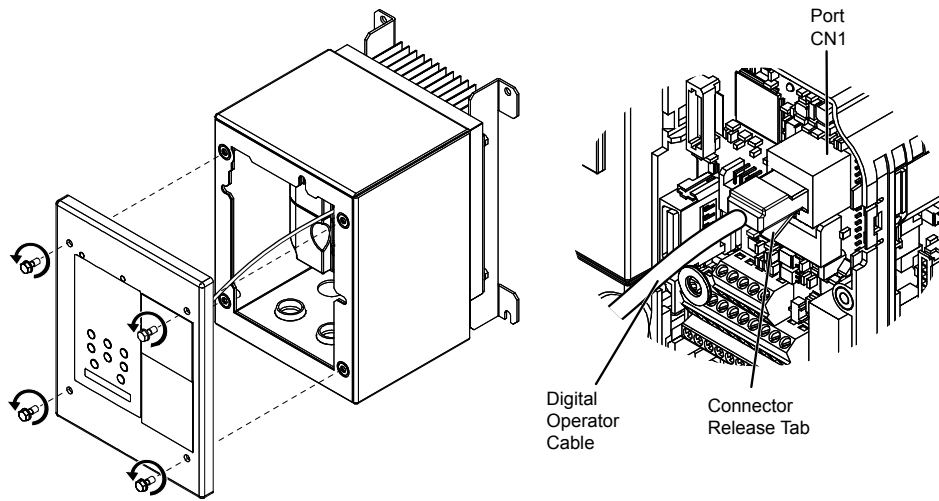
- Loosen the 4 bolts that attach the enclosure front cover in place, gently move the front cover away from the enclosure. Refer to [Table 3.2](#) for installation bolt size.

Press firmly on the digital operator cable connector release tab to disconnect the cable from port CN1 on the drive, then remove the front cover.

Table 3.2 IP66/NEMA 4X, UL Type 4X Enclosure Front Cover Installation Bolt Size and Torque

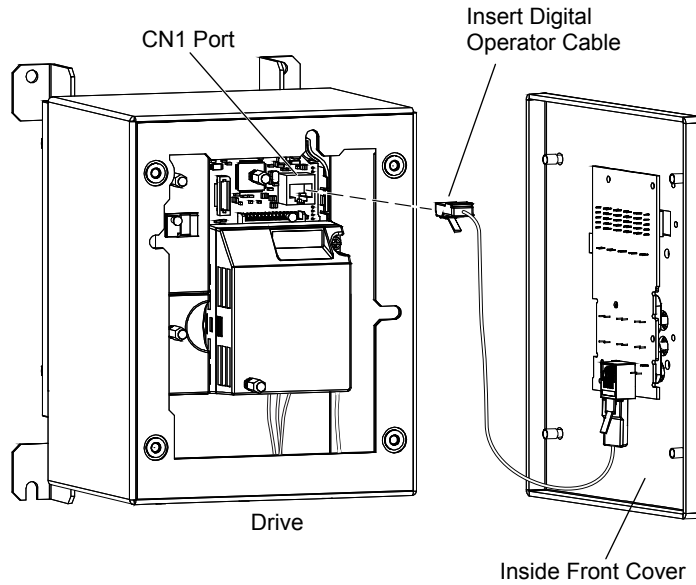
| Voltage Class            | Drive Model        | Installation Bolt Size | Tightening Torque N•m (lb-in) |
|--------------------------|--------------------|------------------------|-------------------------------|
| Single-Phase 200 V Class | BV0001G to BV0012G | M5                     | 2.0 to 2.5 (17.7 to 22.1)     |
| Three-Phase 200 V Class  | 2V0001G to 2V0020G | M5                     | 2.0 to 2.5 (17.7 to 22.1)     |
|                          | 2V0030G to 2V0069G | M6                     | 5.4 to 6.0 (47.8 to 53)       |
| Three-Phase 400 V Class  | 4V0001G to 4V0011G | M5                     | 2.0 to 2.5 (17.7 to 22.1)     |
|                          | 4V0018G to 4V0038G | M6                     | 5.4 to 6.0 (47.8 to 53)       |





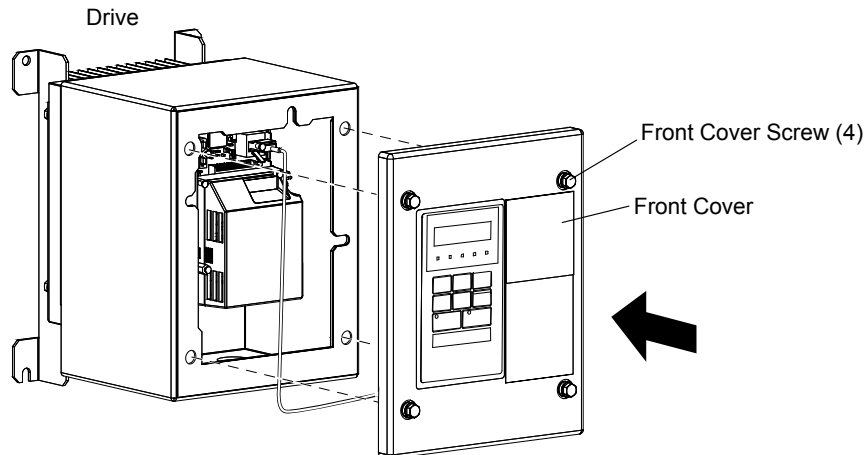
**Figure 3.14 Remove the Enclosure Front Cover**

2. Reattach the digital operator cable to the drive.



**Figure 3.15 Insert Digital Operator Cable**

3. Reattach the front cover of the drive enclosure. Refer to [Table 3.2](#) for tightening torque specifications.



**Figure 3.16 Attach Enclosure Cover**

## 3.6 Main Circuit Wiring

This section describes the functions, specifications, and procedures required to safely and properly wire the main circuit of the drive.

**NOTICE:** Do not solder the ends of wire connections to the drive. Soldered wiring connections can loosen over time. Improper wiring practices could result in drive malfunction due to loose terminal connections.

### ◆ Main Circuit Terminal Functions

**Table 3.3 Main Circuit Terminal Functions**

| Terminal           | Type                            | Function   | Reference |
|--------------------|---------------------------------|--|-----------|
| R/L1               | Main circuit power supply input | Connects line power to the drive. Drives with single-phase 200 V input power use terminals R/L1 and S/L2 only. Do NOT use T/L3.      | –         |
| S/L2               |                                 |  |           |
| T/L3               |                                 |  |           |
| U/T1               | Drive output                    | Connects to the motor.   | 53        |
| V/T2               |                                 |  |           |
| W/T3               |                                 |  |           |
| B1                 | Braking resistor                | Available for connecting a braking resistor or the braking resistor unit option.   | –         |
| B2                 |                                 |  |           |
| ⊕1                 | DC link choke connection        | These terminals are shorted at shipment. Remove the shorting bar between ⊕1 and ⊕2 when connecting a DC link choke to this terminal. | –         |
| ⊕2                 |                                 |  |           |
| ⊕1                 | DC power supply input           | For connecting a DC power supply.  | –         |
| ⊖                  |                                 |  |           |
| ⊕<br>(2 terminals) | Ground                          | Grounding Terminal   | 53        |

### ◆ Wire Gauges and Tightening Torques

Select the appropriate wires and crimp terminals from [Table 3.4](#) through [Table 3.6](#).

- Note:**
- Wire gauge recommendations based on drive continuous current ratings using 75 °C 600 Vac vinyl-sheathed wire assuming ambient temperature within 30 °C and wiring distance shorter than 100 m.
  - Terminals ⊕1, ⊕2, ⊖, B1 and B2 are for connecting optional devices such as a braking resistor. Do not connect other non-specified devices to these terminals.

- Consider the amount of voltage drop when selecting wire gauges. Increase the wire gauge when the voltage drop is greater than 2% of motor rated voltage. Ensure the wire gauge is suitable for the terminal block. Use the following formula to calculate the amount of voltage drop:
- Line drop voltage (V) =  $\sqrt{3}$  x wire resistance (Ω/km) x wire length (m) x current (A) x 10<sup>-3</sup>
- Refer to instruction manual TOBP C720600 00 for braking unit or braking resistor unit wire gauges.
- [Refer to UL Standards Compliance on page 427](#) for information on UL compliance.

### ■ Single-Phase 200 V Class

**Table 3.4 Wire Gauge and Torque Specifications**

| Drive Model | Terminal         | Recomm. Gauge AWG, kcmil | Wire Range AWG, kcmil | Screw Size | Tightening Torque N•m (lb.in.) |
|-------------|------------------|--------------------------|-----------------------|------------|--------------------------------|
| BV0006      | R/L1, S/L2, T/L3 | 12                       | 14 to 10              | M4         | 1.2 to 1.5<br>(10.6 to 13.3)   |
|             | U/T1, V/T2, W/T3 | 14                       | 14 to 10              |            |                                |
|             | ⊖, ⊕1, ⊕2        | –                        | 14 to 10              |            |                                |
|             | B1, B2           | –                        | 14 to 10              |            |                                |
|             | ⊕                | 10                       | 14 to 10              |            |                                |
| BV0010      | R/L1, S/L2, T/L3 | 10                       | 14 to 10              | M4         | 1.2 to 1.5<br>(10.6 to 13.3)   |
|             | U/T1, V/T2, W/T3 | 14                       | 14 to 10              |            |                                |
|             | ⊖, ⊕1, ⊕2        | –                        | 14 to 10              |            |                                |
|             | B1, B2           | –                        | 14 to 10              |            |                                |
|             | ⊕                | 10                       | 14 to 10              |            |                                |

| Drive Model | Terminal         | Recomm. Gauge AWG, kcmil | Wire Range AWG, kcmil | Screw Size | Tightening Torque N•m (lb.in.) |
|-------------|------------------|--------------------------|-----------------------|------------|--------------------------------|
| BV0012      | R/L1, S/L2, T/L3 | 10                       | 14 to 10              | M4         | 2.3 to 2.5<br>(20.4 to 22.1)   |
|             | U/T1, V/T2, W/T3 | 14                       | 14 to 10              |            |                                |
|             | ⊖, ⊕1, ⊕2        | –                        | 14 to 10              |            |                                |
|             | B1, B2           | –                        | 14 to 10              |            |                                |
|             | ⊕                | 10                       | 14 to 10              |            |                                |
| BV0018      | R/L1, S/L2, T/L3 | 8                        | 12 to 8               | M5         | 2.3 to 2.5<br>(20.4 to 22.1)   |
|             | U/T1, V/T2, W/T3 | 10                       | 12 to 8               |            |                                |
|             | ⊖, ⊕1, ⊕2        | –                        | 12 to 8               |            |                                |
|             | B1, B2           | –                        | 12 to 8               |            |                                |
|             | ⊕                | 8                        | 12 to 8               |            | 2 to 2.5<br>(17.7 to 22.1)     |

■ Three-Phase 200 V Class

Table 3.5 Wire Gauge and Torque Specifications

| Drive Model | Terminal         | Recomm. Gauge AWG, kcmil | Wire Range AWG, kcmil | Screw Size | Tightening Torque N•m (lb.in.) |
|-------------|------------------|--------------------------|-----------------------|------------|--------------------------------|
| 2V0006      | R/L1, S/L2, T/L3 | 14                       | 18 to 14              | M3.5       | 0.8 to 1.0<br>(7.1 to 8.9)     |
|             | U/T1, V/T2, W/T3 | 14                       | 18 to 14              |            |                                |
|             | ⊖, ⊕1, ⊕2        | –                        | 18 to 14              |            |                                |
|             | B1, B2           | –                        | 18 to 14              |            |                                |
|             | ⊕                | 14                       | 18 to 14              |            |                                |
| 2V0010      | R/L1, S/L2, T/L3 | 12                       | 14 to 10              | M4         | 1.2 to 1.5<br>(10.6 to 13.3)   |
|             | U/T1, V/T2, W/T3 | 14                       | 14 to 10              |            |                                |
|             | ⊖, ⊕1, ⊕2        | –                        | 14 to 10              |            |                                |
|             | B1, B2           | –                        | 14 to 10              |            |                                |
|             | ⊕                | 10                       | 14 to 10              |            |                                |
| 2V0012      | R/L1, S/L2, T/L3 | 12                       | 14 to 10              | M4         | 1.2 to 1.5<br>(10.6 to 13.3)   |
|             | U/T1, V/T2, W/T3 | 14                       | 14 to 10              |            |                                |
|             | ⊖, ⊕1, ⊕2        | –                        | 14 to 10              |            |                                |
|             | B1, B2           | –                        | 14 to 10              |            |                                |
|             | ⊕                | 10                       | 14 to 10              |            |                                |
| 2V0020      | R/L1, S/L2, T/L3 | 10                       | 14 to 10              | M4         | 1.2 to 1.5<br>(10.6 to 13.3)   |
|             | U/T1, V/T2, W/T3 | 10                       | 14 to 10              |            |                                |
|             | ⊖, ⊕1, ⊕2        | –                        | 14 to 10              |            |                                |
|             | B1, B2           | –                        | 14 to 10              |            |                                |
|             | ⊕                | 10                       | 14 to 10              |            |                                |
| 2V0030      | R/L1, S/L2, T/L3 | 8                        | 10 to 6               | M4         | 2.1 to 2.3<br>(18.6 to 20.4)   |
|             | U/T1, V/T2, W/T3 | 8                        | 10 to 6               |            |                                |
|             | ⊖, ⊕1, ⊕2        | –                        | 10 to 6               |            |                                |
|             | B1, B2           | –                        | 14 to 10              | M5         | 2 to 2.5<br>(17.7 to 22.1)     |
|             | ⊕                | 8                        | 10 to 6               |            |                                |
| 2V0040      | R/L1, S/L2, T/L3 | 6                        | 10 to 6               | M4         | 2.1 to 2.3<br>(18.6 to 20.4)   |
|             | U/T1, V/T2, W/T3 | 8                        | 10 to 6               |            |                                |
|             | ⊖, ⊕1, ⊕2        | –                        | 10 to 6               |            |                                |
|             | B1, B2           | –                        | 14 to 10              |            |                                |
|             | ⊕                | 6                        | 10 to 6               | M5         | 2 to 2.5<br>(17.7 to 22.1)     |

### 3.6 Main Circuit Wiring

| Drive Model | Terminal         | Recomm. Gauge AWG, kcmil | Wire Range AWG, kcmil | Screw Size | Tightening Torque N•m (lb.in.) |
|-------------|------------------|--------------------------|-----------------------|------------|--------------------------------|
| 2V0056      | R/L1, S/L2, T/L3 | 4                        | 6 to 4                | M6         | 5.4 to 6.0<br>(47.8 to 53.1)   |
|             | U/T1, V/T2, W/T3 | 4                        | 6 to 4                |            |                                |
|             | ⊖, ⊕1, ⊕2        | –                        | 6 to 4                |            |                                |
|             | B1, B2           | –                        | 10 to 6               | M5         | 2.7 to 3.0<br>(23.9 to 26.6)   |
|             | ⊕                | 6                        | 8 to 4                | M6         | 5.4 to 6.0<br>(47.8 to 53.1)   |
| 2V0069      | R/L1, S/L2, T/L3 | 3                        | 8 to 2                | M8         | 9.9 to 11<br>(87.6 to 97.4)    |
|             | U/T1, V/T2, W/T3 | 3                        | 8 to 2                |            |                                |
|             | ⊖, ⊕1, ⊕2        | –                        | 8 to 2                |            |                                |
|             | B1, B2           | –                        | 8 to 6                | M5         | 2.7 to 3.0<br>(23.9 to 26.6)   |
|             | ⊕                | 6                        | 6 to 4                | M6         | 5.4 to 6.0<br>(47.8 to 53.1)   |

### ■ Three-Phase 400 V Class

Table 3.6 Wire Gauge and Torque Specifications

| Drive Model                | Terminal         | Recomm. Gauge AWG, kcmil | Wire Range AWG, kcmil | Screw Size | Tightening Torque N•m (lb.in.) |
|----------------------------|------------------|--------------------------|-----------------------|------------|--------------------------------|
| 4V0002<br>4V0004           | R/L1, S/L2, T/L3 | 14                       | 14 to 10              | M4         | 1.2 to 1.5<br>(10.6 to 13.3)   |
|                            | U/T1, V/T2, W/T3 | 14                       | 14 to 10              |            |                                |
|                            | ⊖, ⊕1, ⊕2        | –                        | 14 to 10              |            |                                |
|                            | B1, B2           | –                        | 14 to 10              |            |                                |
|                            | ⊕                | 14                       | 14 to 10              |            |                                |
| 4V0005<br>4V0007<br>4V0009 | R/L1, S/L2, T/L3 | 14                       | 14 to 10              | M4         | 1.2 to 1.5<br>(10.6 to 13.3)   |
|                            | U/T1, V/T2, W/T3 | 14                       | 14 to 10              |            |                                |
|                            | ⊖, ⊕1, ⊕2        | –                        | 14 to 10              |            |                                |
|                            | B1, B2           | –                        | 14 to 10              |            |                                |
|                            | ⊕                | 10                       | 14 to 10              |            |                                |
| 4V0011                     | R/L1, S/L2, T/L3 | 12                       | 14 to 10              | M4         | 1.2 to 1.5<br>(10.6 to 13.3)   |
|                            | U/T1, V/T2, W/T3 | 14                       | 14 to 10              |            |                                |
|                            | ⊖, ⊕1, ⊕2        | –                        | 14 to 10              |            |                                |
|                            | B1, B2           | –                        | 14 to 10              |            |                                |
|                            | ⊕                | 10                       | 14 to 10              |            |                                |
| 4V0018                     | R/L1, S/L2, T/L3 | 10                       | 14 to 6               | M4         | 2.1 to 2.3<br>(18.6 to 20.4)   |
|                            | U/T1, V/T2, W/T3 | 10                       | 14 to 6               |            |                                |
|                            | ⊖, ⊕1, ⊕2        | –                        | 14 to 6               |            |                                |
|                            | B1, B2           | –                        | 14 to 10              |            |                                |
|                            | ⊕                | 8                        | 14 to 6               | M5         | 2 to 2.5<br>(17.7 to 22.1)     |
| 4V0023                     | R/L1, S/L2, T/L3 | 10                       | 10 to 6               | M4         | 2.1 to 2.3<br>(18.6 to 20.4)   |
|                            | U/T1, V/T2, W/T3 | 10                       | 10 to 6               |            |                                |
|                            | ⊖, ⊕1, ⊕2        | –                        | 10 to 6               |            |                                |
|                            | B1, B2           | –                        | 14 to 10              |            |                                |
|                            | ⊕                | 8                        | 10 to 6               | M5         | 2 to 2.5<br>(17.7 to 22.1)     |

| Drive Model | Terminal         | Recomm. Gauge<br>AWG, kcmil | Wire Range<br>AWG, kcmil | Screw Size | Tightening Torque<br>N•m (lb.in.) |
|-------------|------------------|-----------------------------|--------------------------|------------|-----------------------------------|
| 4V0031      | R/L1, S/L2, T/L3 | 8                           | 10 to 6                  | M5         | 3.6 to 4.0<br>(31.8 to 35.4)      |
|             | U/T1, V/T2, W/T3 | 8                           | 10 to 6                  |            |                                   |
|             | ⊖, ⊕1, ⊕2        | –                           | 10 to 6                  |            |                                   |
|             | B1, B2           | –                           | 14 to 10                 | M6         | 2.7 to 3.0<br>(23.9 to 26.6)      |
|             | ⊕                | 6                           | 10 to 6                  | M6         | 5.4 to 6.0<br>(47.8 to 53.1)      |
| 4V0038      | R/L1, S/L2, T/L3 | 6                           | 10 to 6                  | M5         | 3.6 to 4.0<br>(31.8 to 35.4)      |
|             | U/T1, V/T2, W/T3 | 8                           | 10 to 6                  |            |                                   |
|             | ⊖, ⊕1, ⊕2        | –                           | 10 to 6                  |            |                                   |
|             | B1, B2           | –                           | 10 to 8                  | M6         | 2.7 to 3.0<br>(23.9 to 26.6)      |
|             | ⊕                | 6                           | 10 to 6                  | M6         | 5.4 to 6.0<br>(47.8 to 53.1)      |

### ◆ Main Circuit Terminal Power Supply and Motor Wiring

This section outlines the various steps, precautions, and checkpoints for wiring the main circuit terminals and motor terminals.

**NOTICE:** When connecting the motor to the drive output terminals U/T1, V/T2, and W/T3, the phase order for the drive and motor should match. Failure to comply with proper wiring practices may cause the motor to run in reverse if the phase order is backward.

**NOTICE:** Route motor leads U/T1, V/T2, and W/T3 separate from all other leads to reduce possible interference related issues. Failure to comply may result in abnormal operation of drive and nearby equipment.

**NOTICE:** Do not connect phase-advancing capacitors or LC/RC noise filters to the output circuits. Improper application of noise filters could result in damage to the drive.

**NOTICE:** Do not connect the AC power line to the output motor terminals of the drive. Failure to comply could result in death or serious injury by fire as a result of drive damage from line voltage application to output terminals.

### ■ Cable Length Between Drive and Motor

When the cable length between the drive and the motor is too long (especially at low frequency output), note that the cable voltage drop may cause reduced motor torque. Drive output current will increase as the leakage current from the cable increases. An increase in leakage current may trigger an overcurrent situation and weaken the accuracy of the current detection.

Adjust the drive carrier frequency according to the following table. If the motor wiring distance exceeds 100 m because of the system configuration, reduce the ground currents.

Refer to [Table 3.7](#) to set the carrier frequency to an appropriate level.

**Table 3.7 Cable Length Between Drive and Motor**

| Cable Length      | 50 m or shorter | 100 m or shorter | Longer than 100 m |
|-------------------|-----------------|------------------|-------------------|
| Carrier Frequency | 15 kHz or less  | 5 kHz or less    | 2 kHz or less     |

**Note:** When setting carrier frequency, calculate the cable length as the total distance of wiring to all connected motors when running multiple motors from a single drive.

### ■ Ground Wiring

Follow the precautions to wire the ground for one drive or a series of drives.

**WARNING!** Electrical Shock Hazard. Always use a ground wire that complies with technical standards on electrical equipment and minimize the length of the ground wire. Improper equipment grounding may cause dangerous electrical potentials on equipment chassis, which could result in death or serious injury.

**WARNING!** Electrical Shock Hazard. Be sure to ground the drive ground terminal. (200 V Class: Ground to 100 Ω or less, 400 V Class: Ground to 10 Ω or less). Improper equipment grounding could result in death or serious injury by contacting ungrounded electrical equipment.

**NOTICE:** Do not share the ground wire with other devices such as welding machines or large-current electrical equipment. Improper equipment grounding could result in drive or equipment malfunction due to electrical interference.

**NOTICE:** When using more than one drive, ground multiple drives according to instructions. Improper equipment grounding could result in abnormal operation of drive or equipment.

Refer to [Figure 3.17](#) when using multiple drives. Do not loop the ground wire.

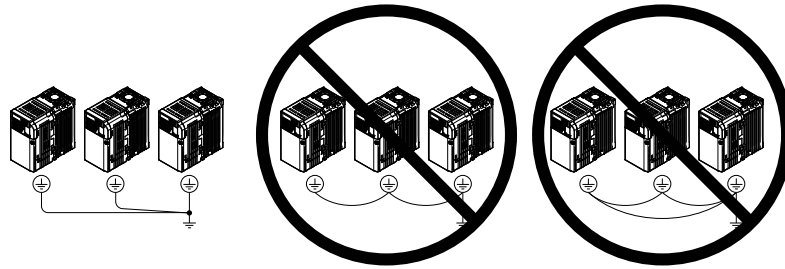
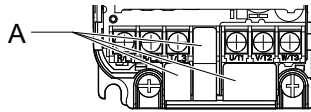


Figure 3.17 Multiple Drive Wiring

### ■ Wiring the Main Circuit Terminal

**WARNING!** *Electrical Shock Hazard. Shut off the power supply to the drive before wiring the main circuit terminals. Failure to comply may result in death or serious injury.*

**Note:** A cover placed over the DC Bus and braking circuit terminals prior to shipment helps prevent miswiring. Cut away covers as needed for terminals with a needle-nose pliers.



**A** –Protective Cover to Prevent Miswiring

**Note:** The ground terminal screw on IP20/NEMA 1, UL Type 1 holds the protective cover in place on model 2V0006.

## 3.7 Control Circuit Wiring

### ◆ Control Circuit Terminal Block Functions

Drive parameters determine which functions apply to the multi-function digital inputs (S1 to S7), multi-function digital outputs (MA, MB), multi-function pulse inputs and outputs (RP, MP) and multi-function photocoupler outputs (P1, P2). The default is called out next to each terminal in [Figure 3.1](#).

**WARNING!** Sudden Movement Hazard. Always check the operation and wiring of control circuits after being wired. Operating a drive with untested control circuits could result in death or serious injury.

**WARNING!** Confirm the drive I/O signals and external sequence before starting test run. Setting parameter A1-06 may change the I/O terminal function automatically from the factory setting. Failure to comply may result in death or serious injury.

### ■ Input Terminals

Table 3.8 Control Circuit Input Terminals

| Type                           | No. | Terminal Name (Function)                                 | Function (Signal Level) Default Setting  |
|--------------------------------|-----|--|--|
| Multi-Function Digital Inputs  | S1  | Multi-function input 1 (Closed: Forward run, Open: Stop) | Photocoupler<br>24 Vdc, 8 mA<br><b>Note:</b> Drive preset to sinking mode. When using source mode, set DIP switch S3 to allow for a 24 Vdc ( $\pm 10\%$ ) external power supply. Refer to <a href="#">Sinking/Sourcing Mode Switch on page 59</a> for details. |
|                                | S2  | Multi-function input 2 (Not used/Through mode)           |  |
|                                | S3  | Multi-function input 3 (External pump fault (N.O.))      |  |
|                                | S4  | Multi-function input 4 (Fault reset)                     |  |
|                                | S5  | Multi-function input 5 (Multi-step speed reference 1)    |  |
|                                | S6  | Multi-function input 6 (HAND Mode)                       |  |
|                                | S7  | Multi-function input 7 (HAND Mode 2)                     |  |
|                                | SC  | Multi-function input common (Control common)             |  |
| Safe Disable Input             | HC  | Power supply for safe disable input                      | +24 Vdc (max 10 mA allowed)  |
|                                | H1  | Safe disable input                                       | Open: Output disabled<br>Closed: Normal operation<br><b>Note:</b> Disconnect wire jumper between HC and H1 when using the safe disable input. The wire length should not exceed 30 m.  |
| Main Frequency Reference Input | RP  | Multi-function pulse train input (frequency reference)   | Response frequency: 0.5 to 32 kHz (Duty Cycle: 30 to 70%)<br>(High level voltage: 3.5 to 13.2 Vdc)<br>(Low level voltage: 0.0 to 0.8 Vdc)<br>(input impedance: 3 k $\Omega$ )  |
|                                | +V  | Analog input power supply                                | +10.5 Vdc (max allowable current 20 mA)  |
|                                | A1  | Multi-function analog input 1 (frequency reference)      | Input voltage 0 to +10 Vdc (20 k $\Omega$ ) resolution 1/1000  |
|                                | A2  | Multi-function analog input 2 (frequency reference)      | Input voltage or input current (Selected by DIP switch S1 and H3-09)<br>0 to +10 Vdc (20 k $\Omega$ ),<br>Resolution: 1/1000<br>4 to 20 mA (250 $\Omega$ ) or 0 to 20 mA (250 $\Omega$ ),<br>Resolution: 1/500   |
|                                | AC  | Frequency reference common                               | 0 Vdc  |

### ■ Output Terminals

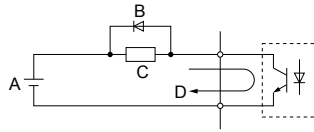
Table 3.9 Control Circuit Output Terminals

| Type                               | No. | Terminal Name (Function)              | Function (Signal Level) Default Setting   |
|------------------------------------|-----|---------------------------------------|---|
| Multi-Function Digital Output <1>  | MA  | N.O. (Fault)                          | Digital output<br>30 Vdc, 10 mA to 1 A; 250 Vac, 10 mA to 1 A<br>Minimum load: 5 Vdc, 10 mA (reference value) |
|                                    | MB  | N.C. (Fault)                          |   |
|                                    | MC  | Digital output common                 |   |
| Multi-Function Photocoupler Output | P1  | Photocoupler output 1 (During run)    | Photocoupler output 48 Vdc, 2 to 50 mA <2>  |
|                                    | P2  | Photocoupler output 2 (Fault)         |   |
|                                    | PC  | Photocoupler output common            |   |
| Monitor Output                     | MP  | Pulse train output (Output frequency) | 32 kHz (max) <3> <4>  |
|                                    | AM  | Analog monitor output                 | 0 to 10 Vdc (2 mA or less) Resolution: 1/1000   |
|                                    | AC  | Monitor common                        | 0 V   |

<1> Do not assign functions to digital relay outputs that involve frequent switching. This may shorten relay performance life. Switching life is estimated at 200,000 times (assumes 1 A, resistive load).

### 3.7 Control Circuit Wiring

- <2> Connect a suppression diode as shown in **Figure 3.18** when driving a reactive load such as a relay coil. Ensure the diode rating is greater than the circuit voltage.
- <3> When set for sourcing, +5 V/1.5 kΩ or higher, +8 V/3.5 kΩ or higher, +10 V/10 kΩ or higher.
- <4> When set for sinking, the external power supply should be +12 Vdc, ±5% with 16 mA or less.



**A** – External power, 48 V max.  
**B** – Suppression diode  
**C** – Coil  
**D** – 50 mA or less

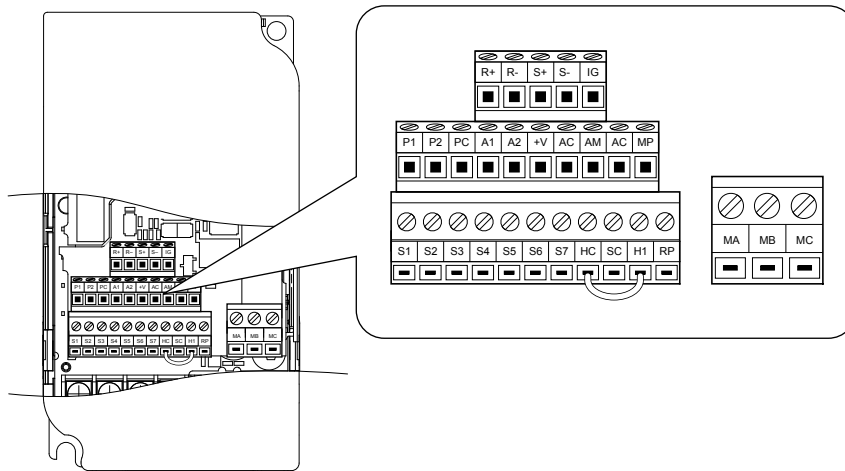
**Figure 3.18** Connecting a Suppression Diode

### Serial Communication Terminals

**Table 3.10** Control Circuit Terminals: Serial Communications

| Type                         | No. | Signal Name               | Function (Signal Level)  |  |
|------------------------------|-----|---------------------------|--|--|
| MEMOBUS/Modbus Communication | R+  | Communications input (+)  | MEMOBUS/Modbus communication: Use a RS-485 or RS-422 cable to connect the drive. | RS-485/422 MEMOBUS/Modbus communication protocol 115.2 kbps (max.) |
|                              | R-  | Communications input (-)  |  |  |
|                              | S+  | Communications output (+) |  |  |
|                              | S-  | Communications output (-) |  |  |
|                              | IG  | Shield ground             | 0 V  |  |

### Terminal Configuration



**Figure 3.19** Removable Control Circuit Terminal Block



### ■ Wire Size and Torque Specifications

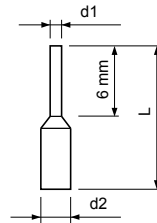
Select appropriate wire type and size from [Table 3.11](#). For simpler and more reliable wiring, crimp ferrules to the wire ends. Refer to [Table 3.12](#) for ferrule terminal types and sizes.

**Table 3.11 Wire Size and Torque Specifications (Same for All Models)**

| Terminal  | Screw Size | Tightening Torque N·m (in-lbs) | Bare Wire Terminal   |                               | Ferrule-Type Terminal                   |                               | Wire Type           |
|---|------------|--------------------------------|--|-------------------------------|---|-------------------------------|---------------------|
|   |            |                                | Applic. wire size mm <sup>2</sup> (AWG)                            | Recomm. mm <sup>2</sup> (AWG) | Applic. wire size mm <sup>2</sup> (AWG) | Recomm. mm <sup>2</sup> (AWG) |                     |
| MA, MB, MC  | M3         | 0.5 to 0.6 (4.4 to 5.3)        | Stranded: 0.25 to 1.5 (24 to 16)<br>Single: 0.25 to 1.5 (24 to 16) | 0.75 (18)                     | 0.25 to 1.0 (24 to 17)                  | 0.5 (20)                      | Shielded line, etc. |
| S1-S7, SC, RP, +V, A1, A2, AC, HC, H1, P1, P2, PC, MP, AM, AC, S+, S-, R+, R-, IG | M2         | 0.22 to 0.25 (1.9 to 2.2)      | Stranded: 0.25 to 1.0 (24 to 18)<br>Single: 0.25 to 1.5 (24 to 16) | 0.75 (18)                     | 0.25 to 0.5 (24 to 20)                  | 0.5 (20)                      |                     |

### ■ Ferrule-Type Wire Terminations

Crimp a ferrule to signal wiring to improve wiring simplicity and reliability. Use CRIMPFOX 6, a crimping tool manufactured by PHOENIX CONTACT.



**Figure 3.20 Ferrule Dimensions**

**Table 3.12 Ferrule Terminal Types and Sizes**

| Size mm <sup>2</sup> (AWG) | Type        | L (mm) | d1 (mm) | d2 (mm) | Manufacturer    |
|----------------------------|-------------|--------|---------|---------|-----------------|
| 0.25 (24)                  | AI 0.25-6YE | 10.5   | 0.8     | 2.0     | PHOENIX CONTACT |
| 0.34 (22)                  | AI 0.34-6TQ | 10.5   | 0.8     | 2.0     |                 |
| 0.5 (20)                   | AI 0.5-6WH  | 12     | 1.1     | 2.5     |                 |
| 0.75 (18)                  | AI 0.75-6GY | 12     | 1.3     | 2.8     |                 |
| 1.0                        | AI 1-6RD    | 12     | 1.5     | 3.0     |                 |

### ◆ Wiring the Control Circuit Terminal

This section describes the proper procedures and preparations for wiring the control terminals.

**WARNING!** *Electrical Shock Hazard. Do not remove covers or touch the circuit boards while the power is on. Failure to comply could result in death or serious injury.*

**NOTICE:** *Separate control circuit wiring from main circuit wiring (terminals R/L1, S/L2, T/L3, B1, B2, U/T1, V/T2, W/T3,  $\ominus$ ,  $\oplus 1$ ,  $\oplus 2$ ) and other high-power lines. Improper wiring practices could result in drive malfunction due to electrical interference.*

**NOTICE:** *Separate wiring for digital output terminals MA, MB and MC from wiring to other control circuit lines. Improper wiring practices could result in drive or equipment malfunction or nuisance trips.*

**NOTICE:** *Use a class 2 power supply (UL standard) when connecting to the control terminals. Improper application of peripheral devices could result in drive performance degradation due to improper power supply.*

**NOTICE:** *Insulate shields with tape or shrink tubing to prevent contact with other signal lines and equipment. Improper wiring practices could result in drive or equipment malfunction due to short circuit.*

**NOTICE:** *Connect the shield of shielded cable to the appropriate ground terminal. Improper equipment grounding could result in drive or equipment malfunction or nuisance trips.*

Wire the control terminals using [Figure 3.21](#) as a guide. Prepare the ends of the control circuit wiring as shown in [Figure 3.22](#). Refer to [Wire Size and Torque Specifications on page 57](#) for details.

### 3.7 Control Circuit Wiring

**NOTICE:** Do not tighten screws beyond the specified tightening torque. Failure to comply may damage the terminal block.

**NOTICE:** Use shielded twisted-pair cables as indicated to prevent operating faults. Improper wiring practices could result in drive or equipment malfunction due to electrical interference.

Connect control wires as shown in the following figure:

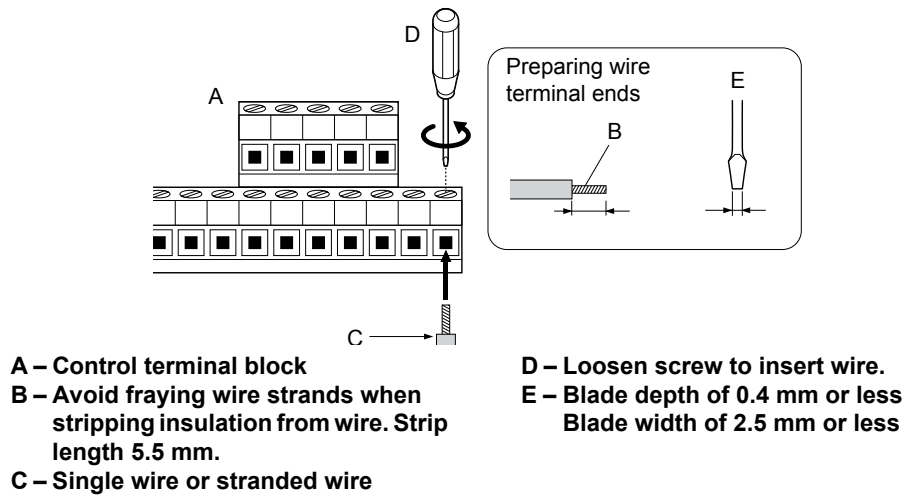


Figure 3.21 Terminal Board Wiring Guide

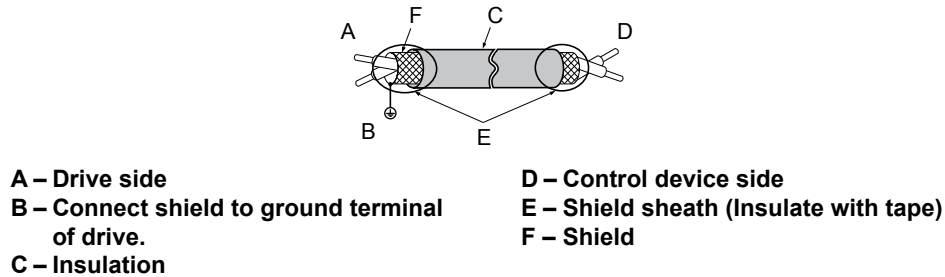


Figure 3.22 Preparing the Ends of Shielded Cables

When setting the frequency by analog reference from an external potentiometer, use shielded twisted-pair wires and ground the shield of twisted-pair wires to the ground terminal of the drive.

**NOTICE:** The analog signal lines between the drive and the operator station or peripheral equipment should not exceed 50 meters when using an analog signal from a remote source to supply the frequency reference. Failure to comply could result in poor system performance.

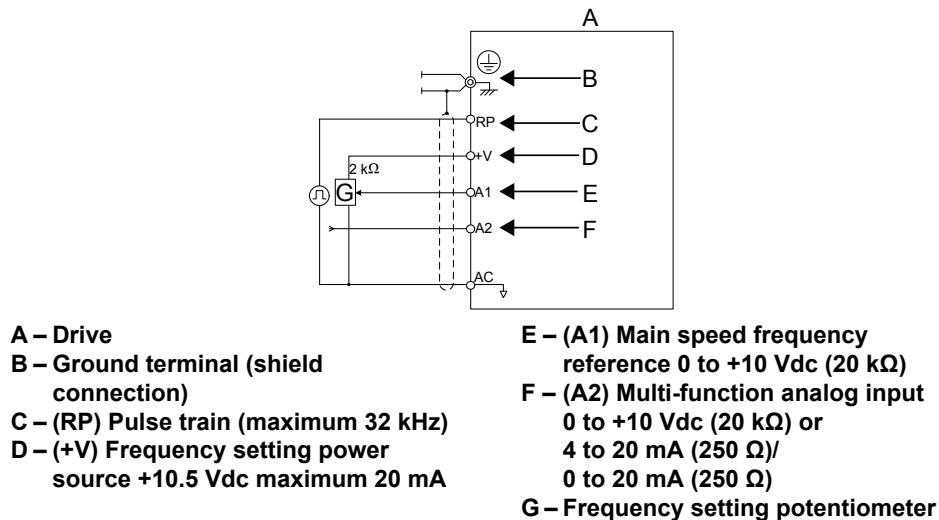


Figure 3.23 Wiring the Frequency Reference to the Control Circuit Terminals (External Reference)

## 3.8 I/O Connections

### ◆ Sinking/Sourcing Mode Switch

Set the DIP switch S3 on the front of the drive to switch the digital input terminal logic between sinking mode and sourcing mode; the drive is preset to sinking mode.

Table 3.13 Sinking/Sourcing Mode Setting

| Set Value | Details                                    |
|-----------|--|
| SINK      | Sinking Mode (0 V common): default setting |
| SOURCE    | Sourcing Mode (+24 V common)               |

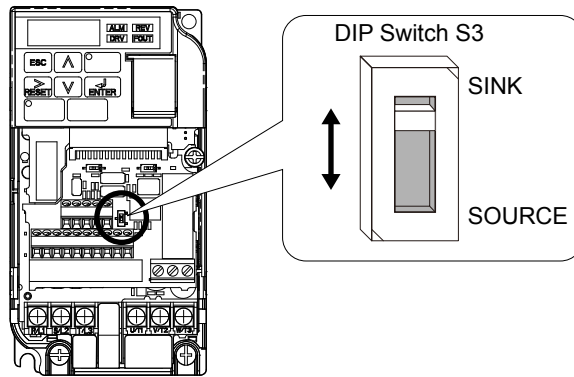


Figure 3.24 DIP Switch S3

### ■ Transistor Input Signal Using 0 V Common/Sink Mode

When controlling the digital inputs by NPN transistors (0 V common/sinking mode), set the DIP switch S3 to SINK and use the internal 24 V power supply.

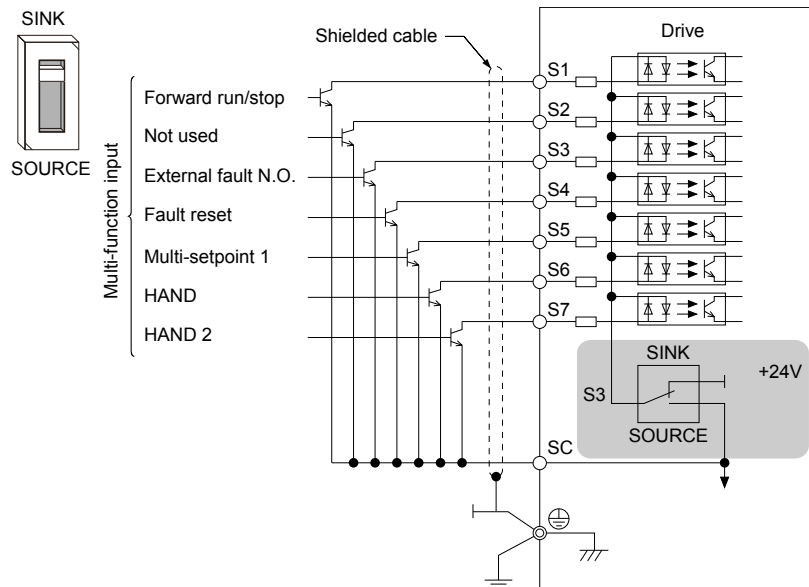


Figure 3.25 Sinking Mode: Sequence from NPN Transistor (0 V Common)

■ Transistor Input Signal Using +24 V Common/Source Mode

When controlling digital inputs by PNP transistors (+24 V common/sourcing mode), set the DIP switch S3 to SOURCE and use an external 24 V power supply.

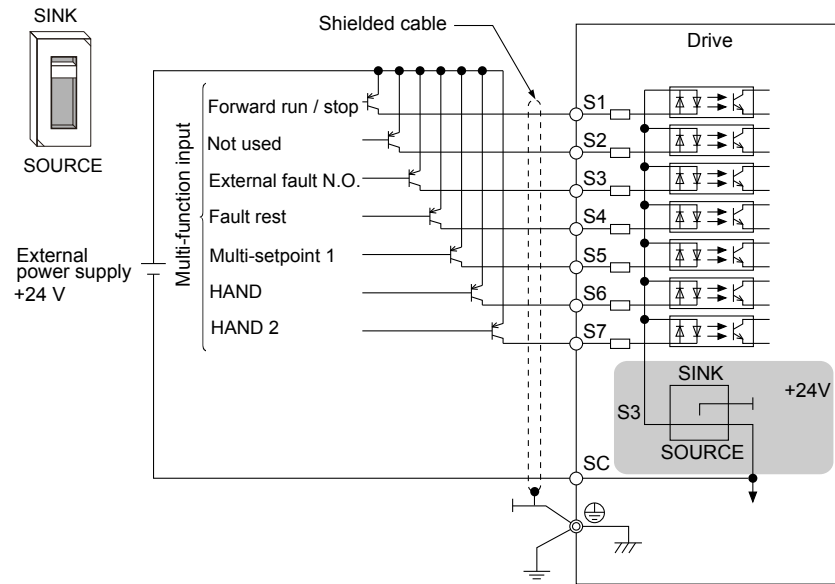


Figure 3.26 Source Mode: Sequence from PNP Transistor (+24 V Common)

## 3.9 Main Frequency Reference

### ◆ DIP Switch S1 Analog Input Signal Selection

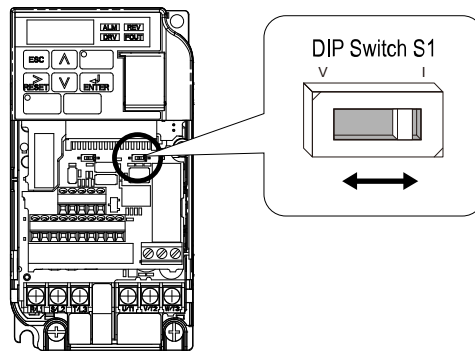
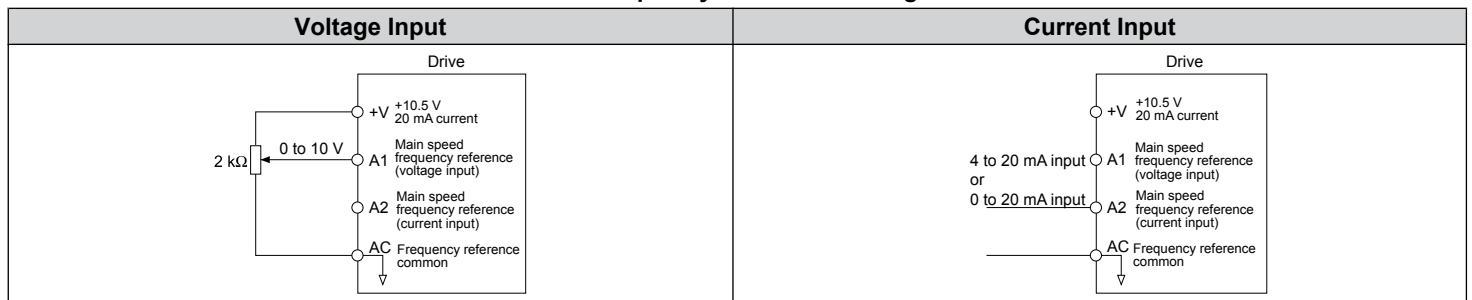
The main frequency reference can either be a voltage or current signal input. For voltage signals both analog inputs, A1 and A2, can be used, for current signals A2 must be used.

When using input A2 as a voltage input, set DIP switch S1 to "V" (left position) and program parameter H3-09 to 0 (0 to +10 Vdc with lower limit) or 1 (0 to +10 Vdc without lower limit).

To use current input at terminal A2, set the DIP switch S1 to "I" (default setting) and set parameter H3-09 = 2 or 3 (4-20 mA or 0-20 mA). Set parameter H3-10 = 0 (frequency reference).

**Note:** If Terminals A1 and A2 are both set for frequency reference (H3-02 = 0 and H3-10 = 0), the addition of both input values builds the frequency reference.

**Table 3.14 Frequency Reference Configurations**



**Figure 3.27 DIP Switch S1**

**Table 3.15 DIP Switch S1 Settings**

| Setting Value      | Description   |
|--------------------|---|
| V (left position)  | Voltage input (0 to 10 V)                                 |
| I (right position) | Current input (4 to 20 mA or 0 to 20 mA): default setting |

**Table 3.16 Parameter H3-09 Details**

| No.   | Parameter Name  | Description  | Setting Range | Default Setting |
|-------|---|--|---------------|-----------------|
| H3-09 | Frequency ref. (current) terminal A2 signal level selection | Selects the signal level for terminal A2.<br>0: 0 to +10 V, unipolar input (with lower limit)<br>1: 0 to +10 V, bipolar input (no lower limit)<br>2: 4 to 20 mA<br>3: 0 to 20 mA | 0 to 3        | 2               |

## 3.10 Wiring Checklist

| <input checked="" type="checkbox"/>         | No. | Item  | Page |
|---|-----|---|------|
| <b>Drive, peripherals, option cards</b>     |     |   |      |
| <input type="checkbox"/>                    | 1   | Check drive model number to ensure receipt of correct model.  | 23   |
| <input type="checkbox"/>                    | 2   | Check for correct braking resistors, DC link chokes, noise filters, and other peripheral devices.   | -    |
| <b>Installation area and physical setup</b> |     |   |      |
| <input type="checkbox"/>                    | 3   | Ensure area surrounding the drive complies with specifications.   | 28   |
| <b>Power supply voltage, output voltage</b> |     |   |      |
| <input type="checkbox"/>                    | 4   | The voltage from the power supply should fall within the input voltage specification range of the drive.  | -    |
| <input type="checkbox"/>                    | 5   | The voltage rating for the motor should match the drive output specifications.  | 23   |
| <b>Main circuit wiring</b>                  |     |   |      |
| <input type="checkbox"/>                    | 6   | Confirm proper branch circuit protection exists per National and Local codes.   | 40   |
| <input type="checkbox"/>                    | 7   | Properly wire the power supply to drive terminals R/L1, S/L2 and T/L3.  | -    |
| <input type="checkbox"/>                    | 8   | Properly wire the drive and motor together.<br>The motor lines and drive output terminals R/T1, V/T2 and W/T3 should match in order to produce the desired phase order. If the phase order is incorrect, the drive will rotate in the opposite direction.   | 53   |
| <input type="checkbox"/>                    | 9   | Use 600 Vac vinyl-sheathed wire for the power supply and motor lines.   | 50   |
| <input type="checkbox"/>                    | 10  | Use the correct wire gauges for the main circuit. Refer to <a href="#">Table 3.4</a> , <a href="#">Table 3.5</a> , or <a href="#">Table 3.6</a> .   | 50   |
|   |     | When using comparatively long motor cable, calculate the amount of voltage drop.<br><div style="border: 1px solid black; padding: 5px; width: fit-content; margin: 5px auto;"><math display="block">\text{Motor rated voltage (V)} \times 0.02 \geq 3 \times \text{voltage resistance } (\Omega/\text{km}) \times \text{cable length (m)} \times \text{motor rated current (A)} \times 10^{-3}</math></div> | 50   |
|   |     | If the cable between the drive and motor exceeds 50 m, adjust the carrier frequency (C6-02) accordingly.  | 53   |
| <input type="checkbox"/>                    | 11  | Properly ground the drive.  | 53   |
| <input type="checkbox"/>                    | 12  | Tightly fasten all terminal screws. Refer to <a href="#">Table 3.4</a> , <a href="#">Table 3.5</a> , or <a href="#">Table 3.6</a> .   | 50   |
| <input type="checkbox"/>                    | 13  | Set up overload protection circuits when running multiple motors from a single drive.<br><p style="text-align: center; font-size: small;">MC1 - MCn ... magnetic contactor<br/>OL 1 - OL n ... thermal relay</p>  | -    |
|   |     | <b>Note:</b> Close MC1 through MCn before operating the drive.  |      |
| <input type="checkbox"/>                    | 14  | If using a braking resistor or dynamic braking resistor unit, install a magnetic contactor. Properly install the resistor, and ensure that overload protection shuts off the power supply.  | -    |
| <input type="checkbox"/>                    | 15  | Verify phase advancing capacitors are NOT installed on the output side of the drive.  | -    |
| <b>Control circuit wiring</b>               |     |   |      |
| <input type="checkbox"/>                    | 16  | Use twisted-pair cables for all drive control circuit wiring.   | -    |
| <input type="checkbox"/>                    | 17  | Ground the shields of shielded wiring to the GND ⊕ terminal.  | 57   |
| <input type="checkbox"/>                    | 18  | If using a 3-Wire sequence, set parameters for MFDI terminals S1 through S7, and properly wire control circuits.  | 42   |
| <input type="checkbox"/>                    | 19  | Check for any other wiring mistakes. Only use a multimeter to check wiring.   | -    |
| <input type="checkbox"/>                    | 20  | Properly fasten the control circuit terminal screws in the drive. Refer to <a href="#">Table 3.4</a> , <a href="#">Table 3.5</a> , or <a href="#">Table 3.6</a> .   | 50   |
| <input type="checkbox"/>                    | 21  | Pick up all wire clippings.   | -    |
| <input type="checkbox"/>                    | 22  | Ensure that no frayed wires on the terminal block are touching other terminals or connections.  | -    |
| <input type="checkbox"/>                    | 23  | Properly separate control circuit wiring and main circuit wiring.   | -    |
| <input type="checkbox"/>                    | 24  | Analog signal line wiring should not exceed 50 m.   | -    |
| <input type="checkbox"/>                    | 25  | Safe Disable Input wiring should not exceed 30 m.   | -    |

# Start-Up Programming & Operation

---

This chapter explains startup procedures and digital operator keypad functions, and gives instructions on programming the drive for initial operation and other important functions.

|             |   |            |
|-------------|---|------------|
| <b>4.1</b>  | <b>SECTION SAFETY.....</b>                                      | <b>64</b>  |
| <b>4.2</b>  | <b>DRIVE START-UP PREPARATION.....</b>                          | <b>66</b>  |
| <b>4.3</b>  | <b>POWERING UP THE DRIVE.....</b>                               | <b>68</b>  |
| <b>4.4</b>  | <b>USING THE STANDARD DIGITAL LED OPERATOR.....</b>             | <b>69</b>  |
| <b>4.5</b>  | <b>THE DRIVE AND PROGRAMMING MODES.....</b>                     | <b>73</b>  |
| <b>4.6</b>  | <b>USING THE OPTIONAL HOA KEYPAD.....</b>                       | <b>74</b>  |
| <b>4.7</b>  | <b>PUMP APPLICATION PRESETS.....</b>                            | <b>86</b>  |
| <b>4.8</b>  | <b>IQPUMP PRESETS AND FUNCTIONS.....</b>                        | <b>87</b>  |
| <b>4.9</b>  | <b>AUTO-TUNING.....</b>   | <b>101</b> |
| <b>4.10</b> | <b>NO-LOAD OPERATION TEST RUN.....</b>                          | <b>104</b> |
| <b>4.11</b> | <b>TEST RUN WITH LOAD CONNECTED.....</b>                        | <b>105</b> |
| <b>4.12</b> | <b>VERIFYING PARAMETER SETTINGS AND BACKING UP CHANGES.....</b> | <b>106</b> |
| <b>4.13</b> | <b>TEST RUN CHECKLIST.....</b>                                  | <b>108</b> |

## 4.1 Section Safety

### DANGER

#### Electrical Shock Hazard

**Do not connect or disconnect wiring while the power is on.**

Failure to comply will result in death or serious injury.

### WARNING

#### Electrical Shock Hazard

**Do not operate equipment with covers removed.**

Failure to comply could result in death or serious injury.

The diagrams in this section may include drives without covers or safety shields to illustrate details. Be sure to reinstall covers or shields before operating the drives and run the drives according to the instructions described in this manual.

**Always ground the motor-side grounding terminal.**

Improper equipment grounding could result in death or serious injury by contacting the motor case.

**Do not touch any terminals before the capacitors have fully discharged.**

Failure to comply could result in death or serious injury.

Before wiring terminals, disconnect all power to the equipment. The internal capacitor remains charged even after the power supply is turned off. The charge indicator LED will extinguish when the DC bus voltage is below 50 Vdc. To prevent electric shock, wait at least five minutes after all indicators are off and measure the DC bus voltage level to confirm safe level.

**Do not allow unqualified personnel to perform work on the drive.**

Failure to comply could result in death or serious injury.

Installation, maintenance, inspection, and servicing must be performed only by authorized personnel familiar with installation, adjustment and maintenance of AC drives.

**Do not perform work on the drive while wearing loose clothing, jewelry or without eye protection.**

Failure to comply could result in death or serious injury.

Remove all metal objects such as watches and rings, secure loose clothing, and wear eye protection before beginning work on the drive.

**Do not remove covers or touch circuit boards while the power is on.**

Failure to comply could result in death or serious injury.

#### Fire Hazard

**Tighten all terminal screws to the specified tightening torque.**

Loose electrical connections could result in death or serious injury by fire due to overheating of electrical connections.

**Do not use an improper voltage source.**

Failure to comply could result in death or serious injury by fire.

Verify that the rated voltage of the drive matches the voltage of the incoming power supply before applying power.

**Do not use improper combustible materials.**

Failure to comply could result in death or serious injury by fire.

Attach the drive to metal or other noncombustible material.



**NOTICE**

**Observe proper electrostatic discharge procedures (ESD) when handling the drive and circuit boards.**

Failure to comply may result in ESD damage to the drive circuitry.

**Never connect or disconnect the motor from the drive while the drive is outputting voltage.**

Improper equipment sequencing could result in damage to the drive.

**Do not use unshielded cable for control wiring.**

Failure to comply may cause electrical interference resulting in poor system performance. Use shielded twisted-pair wires and ground the shield to the ground terminal of the drive.

**Do not allow unqualified personnel to use the product.**

Failure to comply could result in damage to the drive or braking circuit.

Carefully review instruction manual TOBP C720600 00 when connecting a braking option to the drive.

**Do not modify the drive circuitry.**

Failure to comply could result in damage to the drive and will void warranty.

Yaskawa is not responsible for any modification of the product made by the user. This product must not be modified.

**Check all the wiring to ensure that all connections are correct after installing the drive and connecting any other devices.**

Failure to comply could result in damage to the drive.

## 4.2 Drive Start-Up Preparation

To provide the most reliable drive available and to avoid any extra costs related to loss or reduction of warranty coverage, an authorized Yaskawa service representative should complete this start-up procedure. Please complete the following checklist and maintain it in a secure location, as technical service personnel may request information from this checklist.

**Note:** Refer to *Powering Up the Drive on page 68* prior to powering up the drive for the first time.

Date: \_\_\_\_\_

**Start-Up Person:**

Company Name: \_\_\_\_\_ Start-Up Location: \_\_\_\_\_

Sales Order #: \_\_\_\_\_ Serial #: \_\_\_\_\_

Printed Name: \_\_\_\_\_ Drive Location: \_\_\_\_\_

Phone #: \_\_\_\_\_ Signature: \_\_\_\_\_

**Owner's Representative:**

Printed Name: \_\_\_\_\_ Phone #: \_\_\_\_\_

Company: \_\_\_\_\_ Signature: \_\_\_\_\_

### ◆ Start-Up Checklist

| <input checked="" type="checkbox"/> | No. | Item   |
|-------------------------------------|-----|--|
| <input type="checkbox"/>            | 1   | The drive is thoroughly tested at the factory. The start up person should verify that the drive is free of shipping and installation damage. Shipping damage is not covered by the Yaskawa warranty. Claims must be filed with the shipping company as soon as possible for any potential recovery via insurance.  |
| <input type="checkbox"/>            | 2   | Review the Quick Start Procedure shipped with the drive.   |
| <input type="checkbox"/>            | 3   | Verify that the model number and voltage ratings in the purchase order match the nameplate data for each unit.   |
| <input type="checkbox"/>            | 4   | The location of the drive is important to achieve proper performance and normal operating life.  |
| <input type="checkbox"/>            | 5   | Ensure the drive is on a vertical surface with adequate space for air circulation. Refer to <i>Correct Installation Spacing on page 29</i> for proper spacing.   |
| <input type="checkbox"/>            | 6   | Verify that the proper branch circuit protection is installed in front of the drive. Refer to <i>Factory Recommended Branch Circuit Protection on page 430</i> for proper input fuse or circuit breaker sizing.  |
| <input type="checkbox"/>            | 7   | <b>NOTICE:</b> Separate control circuit wiring from main circuit wiring (terminals R/L1, S/L2, T/L3, B1, B2, U/T1, V/T2, W/T3, $\ominus$ , $\oplus 1$ , $\oplus 2$ ) and other high-power lines. Improper wiring practices could result in drive malfunction due to electrical interference.   |
| <input type="checkbox"/>            | 8   | <b>NOTICE:</b> Insulate shields with tape or shrink tubing to prevent contact with other signal lines and equipment. Improper wiring practices could result in drive or equipment malfunction due to short circuit.  |
| <input type="checkbox"/>            | 9   | <b>WARNING!</b> Electrical Shock Hazard. Do not connect the AC power line to the output terminals of the drive. Failure to comply could result in death or serious injury by fire as a result of drive damage from line voltage application to output terminals.   |
| <input type="checkbox"/>            | 10  | <b>NOTICE:</b> Do not connect phase-advancing capacitors or LC/RC noise filters to the output circuits. Failure to comply could result in damage to the drive, phase-advancing capacitors, LC/RC noise filters or ground fault circuit interrupters.   |
| <input type="checkbox"/>            | 11  | Use crimp insulated terminals or insulated shrink tubing for wiring connections. Wires should have a continuous maximum allowable temperature of 75 °C 600 Vac UL-approved vinyl-sheathed insulation. Consider the amount of voltage drop when selecting wire gauges. Increase the wire gauge when the voltage drop is greater than 2% of motor rated voltage. Ensure the wire gauge is suitable for the terminal block. Use the following formula to calculate the amount of voltage drop:<br>Line drop voltage (V) = 3 × wire resistance (Ω/km) × wire length (m) × current (A) × 10 <sup>-3</sup> |
| <input type="checkbox"/>            | 12  | If the cable between the drive and motor exceeds 50 m (164 ft.), adjust the carrier frequency set C6-02 accordingly.   |
| <input type="checkbox"/>            | 13  | Determine proper wire size for power and motor leads.  |

| <input checked="" type="checkbox"/> | No. | Item   |
|-------------------------------------|-----|--|
| <input type="checkbox"/>            | 14  | <p><b>WARNING!</b> Always ground the ground terminal. (200 V Class: Ground to 100 <math>\Omega</math> or less, 400 V Class: Ground to 10 <math>\Omega</math> or less). Improper equipment grounding could result in death or serious injury by contacting ungrounded electrical equipment.</p> <p>When using multiple drives, ground each drive directly or daisy-chain to the ground pole(s). DO NOT FORM A LOOP WITH THE GROUND LEADS. <i>Refer to Multiple Drive Wiring on page 54.</i></p> |
| <input type="checkbox"/>            | 15  | Review terminal functions of signal and control circuits.  |
| <input type="checkbox"/>            | 16  | Verify if any customer safety devices are required (e.g. External Pump Fault).   |
| <input type="checkbox"/>            | 17  | Record the following motor nameplate information:<br>Voltage: _____ Motor Rated Amps: _____  |
| <input type="checkbox"/>            | 18  | Verify that the commercial power supply is within the rated drive input voltage:<br>Power Supply: _____ Vac Drive Input Voltage: _____ Vac   |
| <input type="checkbox"/>            | 19  | Determine whether three-phase input power or single-phase input power is to be used.   |
| <input type="checkbox"/>            | 20  | Verify that the leads in the three-phase electric motor conduit box are configured for the proper voltage.   |
| <input type="checkbox"/>            | 21  | Ensure Motor Rated Current is less than or equal to drive output amps. If multiple motors are being used, make sure that the Motor Rated Current sum is less than or equal to drive output amp rating. Please note that if multiple motors are being operated from one drive, each motor must have its own overload and short circuit protection.  |
| <input type="checkbox"/>            | 22  | Wire all necessary power leads to the drive.<br><b>DO NOT CONNECT MOTOR TO DRIVE AT THIS TIME.</b>   |
| <input type="checkbox"/>            | 23  | Wire all necessary <b>ground</b> wires to the drive.   |
| <input type="checkbox"/>            | 24  | Wire all necessary <b>control</b> wires to the drive.  |
| <input type="checkbox"/>            | 25  | Ensure that the power leads are connected to the R/L1, S/L2 and T/L3 terminals in the drive. Confirm single-phase input or three-phase input wiring.   |
| <input type="checkbox"/>            | 26  | Tighten all of the three-phase power and ground connections. Please check that all control and signal terminations are tight.  |
| <input type="checkbox"/>            | 27  | Inspect the control circuit connections (including the shield) and determine if a motor safety circuit is connected. If normally closed, these contacts may be wired in series with the RUN command contacts, which are between terminals S1 and SN of the drive. No special programming is required.<br>Alternately, these contacts could be wired between terminals S3 and SN as External Fault Inputs, and may be either normally closed or normally open contacts.                         |
| <input type="checkbox"/>            | 28  | Record any other connections to the drive to determine if special programming is required for the following:<br>Multi-function Inputs<br>Multi-function Outputs<br>Multi-function Digital Inputs<br>Multi-function Analog Outputs<br>Network Communications  |

## 4.3 Powering Up the Drive

### ◆ Powering Up the Drive and Operation Status Display


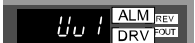
#### ■ Powering Up the Drive

Review the following checklist before turning the power on.

| Item to Check                              | Description  |
|--|--|
| Power supply voltage                       | Ensure the power supply voltage is correct:<br>200 V class: single-phase 200 to 240 Vac 50/60 Hz<br>200 V class: 3-phase 200 to 240 Vac 50/60 Hz<br>400 V class: 3-phase 380 to 480 Vac 50/60 Hz |
|  | Properly wire the power supply input terminals (R/L1, S/L2, T/L3).<br>(for single-phase 200 V class models, wire only R/L1 and S/L2)   |
|  | Check for proper grounding of drive and motor.   |
| Drive output terminals and motor terminals | Properly wire drive output terminals U/T1, V/T2, and W/T3 with motor terminals U, V, and W.  |
| Control circuit terminals                  | Check control circuit terminal connections.  |
| Drive control terminal status              | Open all control circuit terminals (off).  |
| Status of the load and connected machinery | Uncouple the motor from the load.  |

#### ■ Status Display

When the power supply to the drive is turned on, the LED operator lights will appear as follows:

| No.              | Name   | Description   |
|------------------|--|---|
| Normal Operation |                                    | The data display area displays the setpoint. [DRV] is lit.  |
| Fault            | <br>Main circuit low voltage (ex) | Data displayed varies by the type of fault. <i>Refer to Fault Displays, Causes, and Possible Solutions on page 253</i> for more information and possible solution. [ALM] and [DRV] are lit. |

**Note:** Display will vary depending on drive settings.

## 4.4 Using the Standard Digital LED Operator

Use the LED operator to enter run and stop commands, display data, edit parameters, as well as display fault and alarm information.

### ◆ Keys, Displays, and LEDs

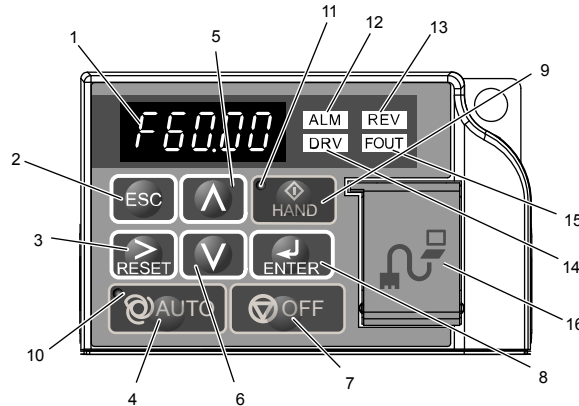





Table 4.1 Keys and Displays on the LED Operator

| No. | Display | Name              | Function   |
|-----|---------|-------------------|--|
| 1   |         | Data Display Area | Displays the setpoint, frequency reference, parameter number, etc.   |
| 2   |         | ESC Key           | Returns to the previous menu.  |
| 3   |         | RESET Key         | Moves the cursor to the right.<br>Resets the drive to clear a fault situation.   |
| 4   |         | AUTO Key          | Selects the source of Run command and frequency reference. <ul style="list-style-type: none"> <li>Set the drive to AUTO mode.</li> <li>Run command input source depends on b1-02.</li> <li>Frequency reference input source depends on b1-01.</li> </ul> |
| 5   |         | Up Arrow Key      | Scrolls up to display the next item, selects parameter numbers, and increments setting values.   |
| 6   |         | Down Arrow Key    | Scrolls down to display the previous item, selects parameter numbers, and decrements setting values.   |
| 7   |         | OFF Key           | Follows the stopping method set in b1-03 to stop drive operation.  |
| 8   |         | ENTER Key         | <ul style="list-style-type: none"> <li>Enters parameter values and settings.</li> <li>Selects a menu item to move between displays.</li> </ul>   |
| 9   |         | HAND Key          | The drive runs at a selectable frequency reference source as set by P5-01. <ul style="list-style-type: none"> <li>Set the drive to HAND mode.</li> <li>When P5-03 is set to 1, HAND and AUTO mode can be switched while the drive is running.</li> </ul> |
| 10  |         | AUTO Light        | Lit while the drive is in AUTO mode. Refer to page 70 for details.   |
| 11  |         | HAND Light        | Lit while the drive is in HAND mode. Refer to page 70 for details.   |
| 12  |         | ALM LED Light     | <i>Refer to LED Screen Displays on page 70.</i>  |
| 13  |         | REV LED Light     |  |
| 14  |         | DRV LED Light     |  |
| 15  |         | FOUT LED Light    |  |

## 4.4 Using the Standard Digital LED Operator



















| No. | Display | Name               | Function   |
|-----|---------|--------------------|--|
| 16  | —       | Communication Port | <p>Port used for USB Copy Unit, LCD Operator Keypad, and for connecting to a PC.</p> <p><b>NOTICE:</b> Use only specified cable when making connections to the drive. Failure to comply may damage the drive.</p> <p><b>NOTICE:</b> Do not open the port cover wider than 90 degrees. Failure to comply may break the port cover and leave the unprotected port susceptible to damage.</p> |

### ◆ LED Screen Displays

| Display                       | Lit   | Flashing  | Off   |
|-------------------------------|---|---|---|
| ALM                           | When the drive detects an alarm or error  | <ul style="list-style-type: none"> <li>When an alarm occurs</li> <li>oPE detected</li> <li>When a fault or error occurs during Auto-Tuning</li> </ul> | Normal state (no fault or alarm)  |
| REV                           | Motor is rotating in reverse  | —   | Motor is rotating forward   |
| DRV                           | Drive Mode Auto-Tuning  | —   | Programming Mode  |
| FOUT                          | Displays output frequency (Hz)  | —   | —   |
| As illustrated in this manual |  |    |  |

### ◆ AUTO LED and HAND LED Indications

Table 4.2 AUTO LED and HAND LED Indications

| AUTO LED  | HAND LED  | State  |
|---|---|--|
| <br>Off                    | <br>Off                    | OFF mode   |
| <br>Off                    | <br>On solid               | HAND mode (Also during DC injection braking)   |
| <br>Off                    | <br>Long blink (50% duty)  | HAND mode when the Frequency Reference is 0 and/or decelerating in HAND mode, or during PI Sleep or Snooze.            |
| <br>On solid               | <br>Off                    | Running in AUTO mode (Also during DC injection braking)  |
| <br>Off                    | <br>Short blink (15% duty) | HAND mode, Ready, No Run command input.<br><b>Note:</b> Short Blink for Legacy Operation Mode (S5-04 = 0).             |
| <br>Off                    | <br>Double blink           | HAND mode, cycle the Run command.  |
| <br>Long blink (50% duty)  | <br>Off                    | Running in AUTO mode when the Frequency Reference is 0 and/or decelerating in AUTO mode, or during PI Sleep or Snooze. |
| <br>Short blink (15% duty) | <br>Off                    | AUTO mode, Ready, No run command input.  |
| <br>Double blink           | <br>Off                    | AUTO mode, stopped by a Fast- Stop from a Multi-Function Digital Input.  |

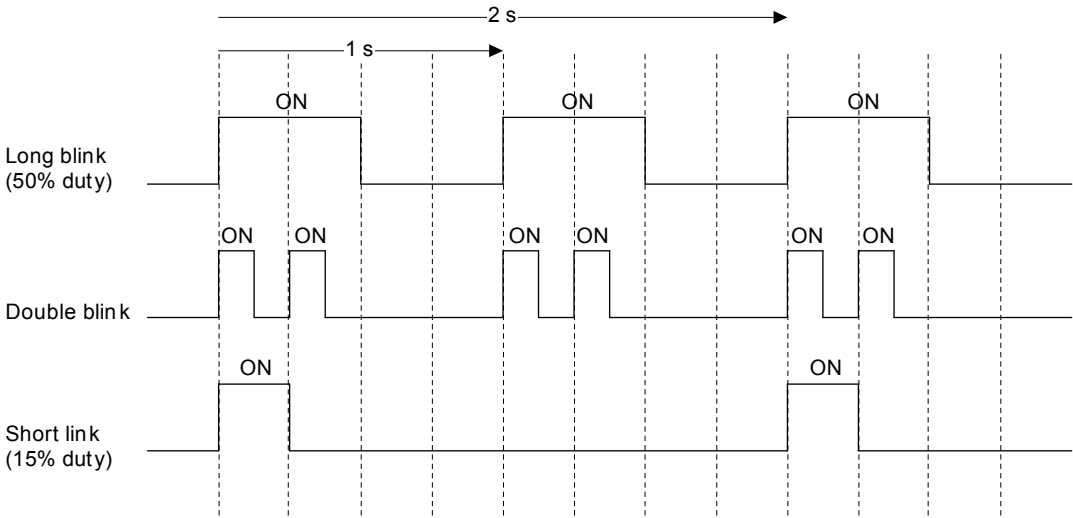


Figure 4.1 AUTO LED and HAND LED Timing Status

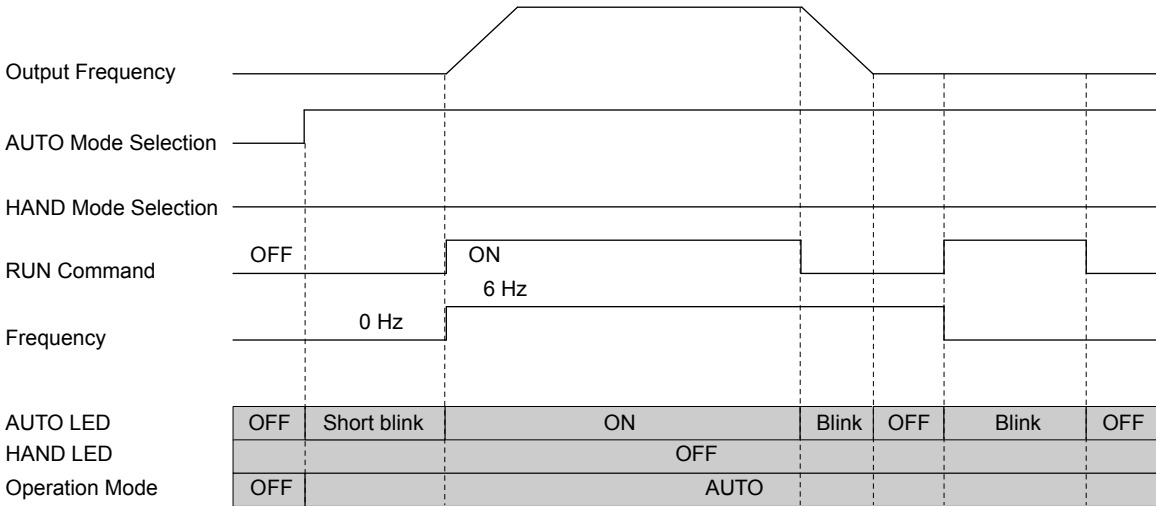


Figure 4.2 LEDs and Drive Operation in AUTO and HAND Modes

◆ Menu Structure for Digital LED Operator

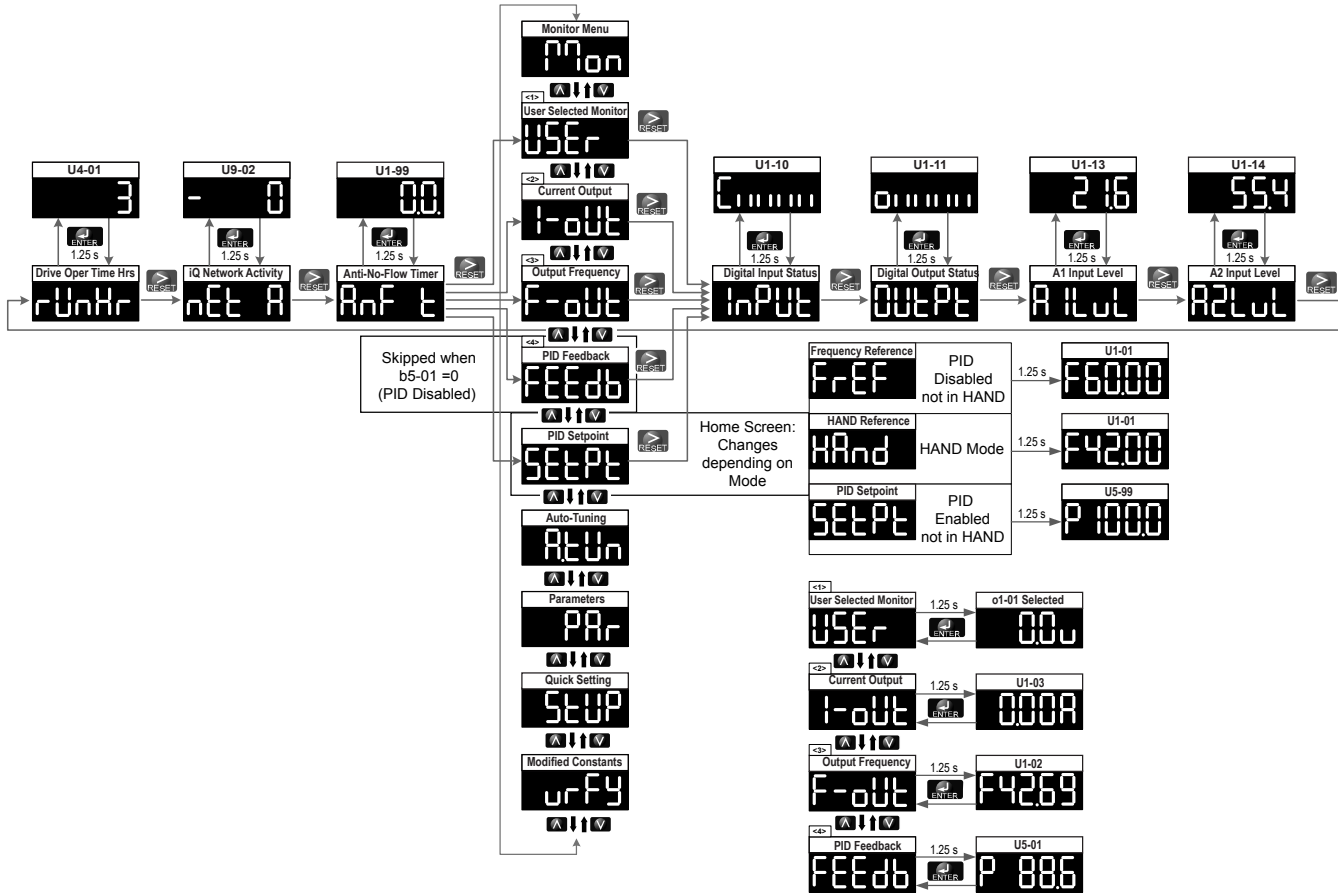


Figure 4.3 Digital LED Operator Screen Structure

■ Home Quick Monitor Display (LED)

The Home Quick Monitor provides an easily accessible preset group of monitors that are frequently used during operation.

FREF or SETPT - U1-01, Frequency Reference, or U5-99, AUTO Setpoint

FEEDB - U1-91, PID Feedback

F-OUT - U1-02, Output Frequency

I-OUT - U1-03, Output Current

USER - Selected Monitor via o1-01 (defaulted to U1-06 Output Voltage)

The following monitors are available via the Quick Monitor:

| Monitor | Name                   |
|---------|------------------------|
| U1-10   | Input Terminal Status  |
| U1-11   | Output Terminal Status |
| U1-13   | Terminal A1 Level      |
| U1-14   | Terminal A2 Level      |

| Monitor | Name                |
|---------|---------------------|
| U4-01   | Drive Elapsed Time  |
| U9-02   | iQ Network Activity |
| U1-99   | Anti-No-Flow Timer  |

When navigating through the preset monitors at the Main Menu or the Quick Monitors, a 5-character descriptive text appears briefly before showing the monitor values.

When viewing a Quick Monitor value, press ENTER to re-display the 5-character descriptive text for a brief time. Press ESC when the Quick Monitor value is displayed to jump to the U1-01, Frequency Reference/U5-99, AUTO Setpoint, monitor.

The PID Setpoint unit is animated with alternating “P” and “S”. The PID Setpoint unit is not shown when the value rises above 4 digits or when in Non-MOP parameter entry mode (Q1-□□ to U5-99)

The PID Feedback unit is animated with a P alternating with a rising level. The PID Feedback unit is not shown when the value rises above 4 digits.



## 4.5 The Drive and Programming Modes

The drive functions are divided into two main groups accessible via the digital LED operator:

**Drive Mode:** The Drive mode allows motor operation and parameter monitoring. Most parameter settings cannot be changed when accessing functions in the Drive Mode.

**Programming Mode:** The Programming Mode allows access to setup/adjust, verify parameters and Auto-Tuning. The drive prohibits changes in motor operation such as start/stop when the Digital LED Operator is accessing a function in the Programming Mode.

### ◆ Changing Parameter Settings or Values

This example explains changing C1-01, Acceleration Time 1, from 10.0 seconds to 20.0 seconds.

| Step |  |   | Display/Result |
|------|--|---|----------------|
| 1.   | Turn on the power to the drive. The initial display appears.                           | → |                |
| 2.   | Press the  key until the Setup Mode Screen appears.                                    | → |                |
| 3.   | Press the  key to view the parameter setting display.                                  | → |                |
| 4.   | Scroll through parameters by pressing the  key until C1-01 appears.                    | → |                |
| 5.   | Press  to view the current setting value (10.0). (Number farthest to the left flashes) | → |                |
| 6.   | Press  until the desired number is selected. ("1" flashes)                             | → |                |
| 7.   | Press the  key and enter 0020.0.   | → |                |
| 8.   | Press  and the drive will confirm the change.  | → |                |
| 9.   | The display automatically returns to the screen shown in Step 4.                       | → |                |
| 10.  | Press the  key until back at the initial display.                                      | → |                |

## 4.6 Using the Optional HOA Keypad

Use the HOA keypad to enter OFF commands, switch AUTO or HAND Mode, change parameters, and display data including fault and alarm information.

### ◆ Keys and Displays

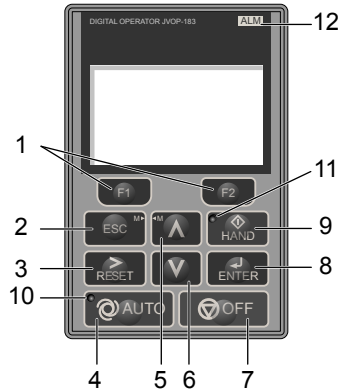


Figure 4.4 Keys and Displays on the HOA Keypad

| No. | Display | Name                  | Function  |
|-----|---------|-----------------------|---|
| 1   |         | Function Key (F1, F2) | The functions assigned to F1 and F2 vary depending on the currently displayed menu. The name of each function appears in the lower half of the display window.  |
| 2   |         | ESC Key               | <ul style="list-style-type: none"> <li>Returns to the previous display.</li> <li>Moves the cursor one space to the left.</li> <li>Pressing and holding this button will return to the Frequency Reference display.</li> </ul>                                     |
| 3   |         | RESET Key             | <ul style="list-style-type: none"> <li>Moves the cursor to the right.</li> <li>Resets the drive to clear a fault situation.</li> </ul>  |
| 4   |         | AUTO Key              | <ul style="list-style-type: none"> <li>Selects the source of Run command and frequency reference.</li> <li>Set the drive to AUTO mode.</li> <li>Run command input source depends on b1-02.</li> <li>Frequency reference input source depends on b1-01.</li> </ul> |
| 5   |         | Up Arrow Key          | Scrolls up to display the next item, selects parameter numbers, and increments setting values.  |
| 6   |         | Down Arrow Key        | Scrolls down to display the previous item, selects parameter numbers, and decrements setting values.  |
| 7   |         | OFF Key               | Follows the stopping method set in b1-03 to stop drive operation.   |
| 8   |         | ENTER Key             | <ul style="list-style-type: none"> <li>Enters parameter values and settings.</li> <li>Selects a menu item to move between displays.</li> </ul>  |
| 9   |         | HAND Key              | <ul style="list-style-type: none"> <li>The drive runs at a selectable frequency reference source as set by P5-01.</li> <li>Set the drive to HAND mode.</li> <li>When P5-03 is set to 1, HAND and AUTO mode can be switched while the drive is running.</li> </ul> |
| 10  |         | AUTO Light            | Lit while the drive is in AUTO mode. Refer to page 70 for details.  |
| 11  |         | HAND Light            | Lit while the drive is in HAND mode. Refer to page 70 for details.  |
| 12  |         | ALM LED Light         | <i>Refer to ALARM (ALM) LED Displays on page 76 for details.</i>  |

◆ LCD Display

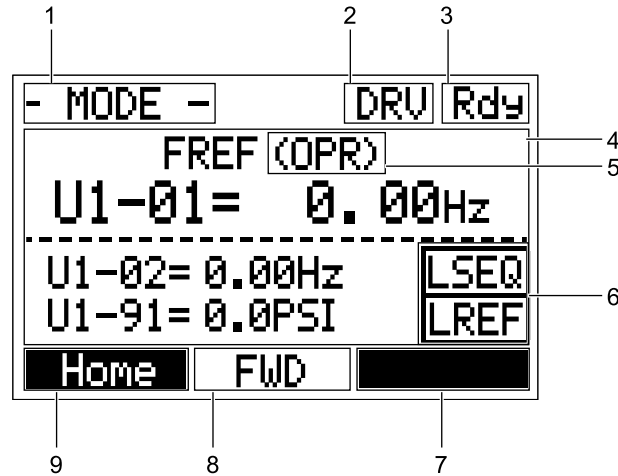







Figure 4.5 LCD Display

Table 4.3 Display and Contents

| No. | Name                                | Display          | Content   |
|-----|-------------------------------------|------------------|---|
| 1   | Operation Mode Menus                | MODE             | Displayed when in Mode Selection.   |
|     |                                     | QMONI: Use F1/F2 | Instructions to access the Quick Monitors.  |
|     |                                     | MENU: Use UP/DWN | Instructions to access the next menu item.  |
|     |                                     | MONITR           | Displayed when in Monitor Mode.   |
|     |                                     | VERIFY           | Indicates the Verify Menu.  |
|     |                                     | PRMSET           | Displayed when in Parameter Setting Mode.   |
|     |                                     | A.TUNE           | Displayed during Auto-Tuning.   |
| 2   | Mode Display Area                   | DRV              | Displayed when in Drive Mode.   |
|     |                                     | PRG              | Displayed when in Programming Mode.   |
| 3   | Ready                               | Rdy              | Indicates the drive is ready to run.  |
| 4   | Data Display                        | —                | Displays specific data and operation data.  |
| 5   | Frequency Reference Assignment <F2> | OPR              | Displayed when the frequency reference is assigned to the HOA keypad.                                       |
|     |                                     | COM              | Displayed when the frequency reference is assigned to the MEMOBUS/Modbus Communication Inputs of the drive. |
|     |                                     | OP               | Displayed when the frequency reference is assigned to option card connected to the drive.                   |
|     |                                     | AI               | Displayed when the function reference is assigned to an analog input.                                       |
|     |                                     | OFF              | Displayed when HAND mode is OFF.  |
| 6   | LOCAL/REMOTE Display <F2>           | RSEQ             | Blinks when the Run command is supplied from a remote source.   |
|     |                                     | LSEQ             | Displayed when the Run command is supplied from the HOA keypad.   |
|     |                                     | RREF             | Blinks when the Run command is supplied from a remote source.   |
|     |                                     | LREF             | Displayed when the Run command is supplied from the HOA keypad.   |
| 7   | Function Key 2 (F2)                 | <-MONITOR->      | Pressing  displays the next Quick Monitor.  |
|     |                                     | DATA             | Pressing  scrolls to the next display.  |
|     |                                     | →                | Pressing  scrolls the cursor to the right.  |
|     |                                     | RESET            | Pressing  resets the existing drive fault error.  |
|     |                                     | Monitor          | Pressing  switches Monitor mode.  |
| 8   | FWD/REV                             | FWD              | Indicates forward motor operation.  |
|     |                                     | REV              | Indicates reverse motor operation.  |

## 4.6 Using the Optional HOA Keypad


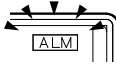

| No. | Name                | Display     | Content   |
|-----|---------------------|-------------|---|
| 9   | Function Key 1 (F1) | <-MONITOR-> | Pressing  displays the previous Quick Monitor.           |
|     |                     | ←           | Pressing  scrolls the cursor to the left.                |
|     |                     | Home        | Pressing  returns to the top menu (Frequency Reference). |
|     |                     | ESC         | Pressing  returns to the previous display.               |
|     |                     | Monitor     | Pressing  switches Monitor mode.                         |

<1> Displayed when in Frequency Reference Mode.

<2> Displayed when in Frequency Reference Mode and Monitor Mode.



















### ◆ ALARM (ALM) LED Displays

Table 4.4 ALARM (ALM) LED Status and Contents

| State       | Content   | Display   |
|-------------|---|---|
| Illuminated | When the drive detects an alarm or error.   |  |
| Flashing    | <ul style="list-style-type: none"> <li>When an alarm occurs.</li> <li>When an oPE is detected.</li> <li>When a fault or error occurs during Auto-Tuning.</li> </ul> |  |
| Off         | Normal operation (no fault or alarm).   |  |

### ◆ AUTO LED and HAND LED Indications

Table 4.5 AUTO LED and HAND LED Indications

| AUTO LED  | HAND LED  | State  |
|---|---|--|
| <br>Off                    | <br>Off                    | OFF mode   |
| <br>Off                    | <br>On solid               | HAND mode (Also during DC injection braking)   |
| <br>Off                    | <br>Long blink (50% duty)  | HAND mode when the Frequency Reference is 0 and/or decelerating in HAND mode, or during PI Sleep or Snooze.            |
| <br>On solid               | <br>Off                    | Running in AUTO mode (Also during DC injection braking)  |
| <br>Off                    | <br>Short blink (15% duty) | HAND mode, Ready, No Run command input.<br><b>Note:</b> Short Blink for Legacy Operation Mode (S5-04 = 0).             |
| <br>Off                    | <br>Double blink           | HAND mode, cycle the Run command.  |
| <br>Long blink (50% duty)  | <br>Off                    | Running in AUTO mode when the Frequency Reference is 0 and/or decelerating in AUTO mode, or during PI Sleep or Snooze. |
| <br>Short blink (15% duty) | <br>Off                    | AUTO mode, Ready, No run command input.  |
| <br>Double blink           | <br>Off                    | AUTO mode, stopped by a Fast- Stop from a Multi-Function Digital Input.  |

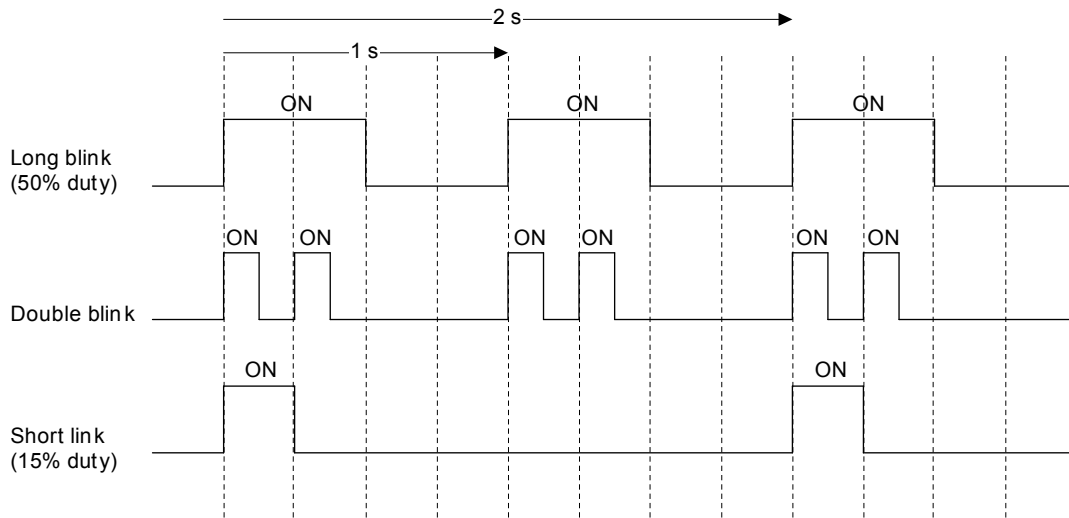


Figure 4.6 AUTO LED and HAND LED Timing Status

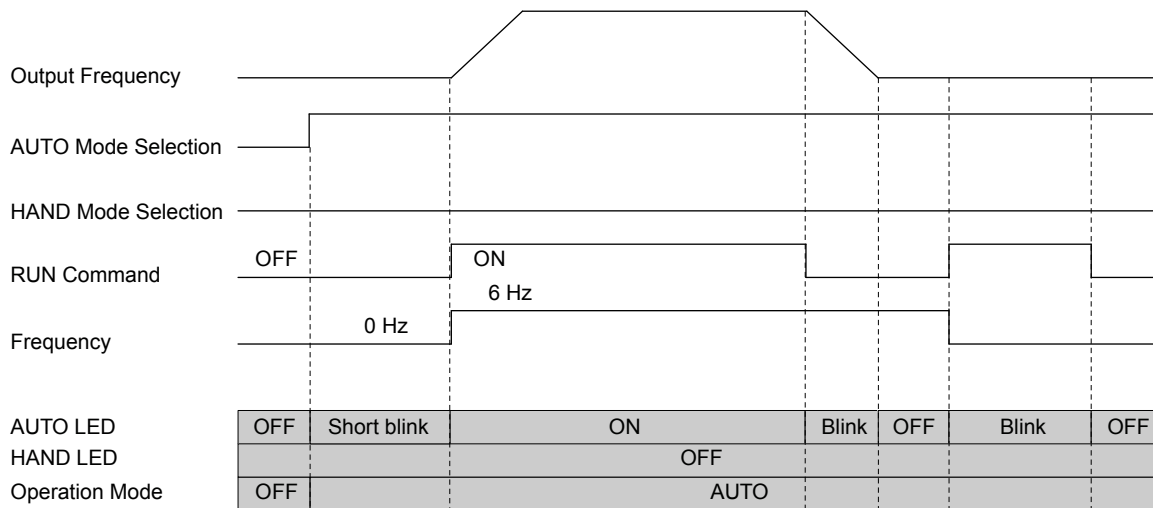


Figure 4.7 LEDs and Drive Operation in AUTO and HAND Modes

### ◆ Setting the Real Time Clock

The time and date must be set when a new HOA keypad is plugged in and the drive is powered up. The HOA keypad will display the time and date setup screen for 30 seconds. If a button is not pressed during this time, the display will clear and a “Clock Not Set” alarm will flash. Pressing the F2 (Data) key will display the setting screen again.

### ■ Feedback Loss Wire Break Alarm

If there is no sensor wired to the drive, a “Feedback Loss – Wire Break” alarm will flash on the display. Providing the proper feedback device signal will clear the Feedback Loss alarm.

The drive requires a feedback device (e.g., pressure transducer, flow meter, etc.) to perform automatic system regulation. Any analog 0~10 V or 4-20 mA feedback device can be used in combination with the drive.

**Note:** The factory default setting for the drive is 4~20 mA feedback device connected to analog input A2.

### ■ Real Time Clock Setting Display

**Note:** Setting the Real-Time Clock will clear a “Clock Not Set” alarm.

## 4.6 Using the Optional HOA Keypad

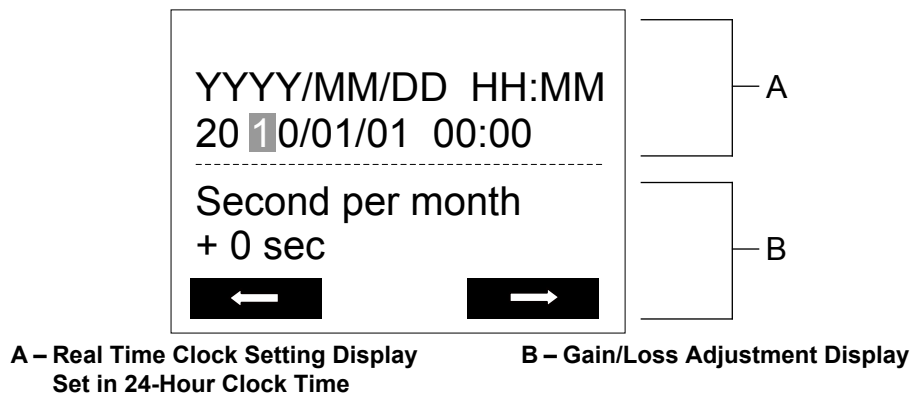


Figure 4.8 Real Time Clock Adjustment Display

| Display          | Description   |
|------------------|---|
| YYYY             | Set the year with the last two digits.  |
| MM               | Set the month with two digits.  |
| DD               | Set the day with two digits.  |
| HH:MM            | Set the hours and minutes, with two digits for each.<br><b>Note:</b> Set in 24-hour clock time. After initial setup, the time will display in 12-hour clock time. |
| Second per month | Set the gain or loss in seconds per month.<br><b>Note:</b> This does not need to be set for the RTC to function properly.   |

### Moving the Cursor

Pressing the F2 key or the RESET key will move the cursor to the digit on the right. Pressing the F1 key will move the cursor to the left.

### Changing Settings

- **Changing YYYY/MM/DD HH:MM:** Pressing the up arrow key will increase the number selected by the cursor from 0 to 9. Pressing the down arrow key will decrease the number selected by the cursor from 0 to 9.
- **Setting the Seconds per Month:** *This setting does not need to be adjusted.* Pressing the up arrow key will increase the number selected by the cursor from -504 to +488 in increments of 8. Pressing the down arrow key will decrease the number selected by the cursor from -504 to +488 in increments of 8.

The feature is used to keep the RTC in sync with an external device clock, like a PLC or BAS system, and will adjust the clock by a set amount of seconds every month.

### Real-Time Clock Setting at Initial Power-up of a New Drive

Setting the Real-time clock is required at power-up of a new HOA operator or after digital operator battery replacement.

Table 4.6 illustrates how to set the Real-Time Clock at initial power-up of a new drive.

Table 4.6 Clock Adjustment Procedure at Power-up of a New Drive

| Procedure  | Display |
|--|---------|
| 1 Turn the power on. The Real Time Clock Adjustment Display will appear. Use the right arrow key to select the desired digit, then set the correct date and 24-hour clock time using the up and down arrow keys. |         |
| 2 After entering the Real-Time Clock data, press the ENTER key to save the changes. The display will indicate “Entry Accepted” and return to the initial display in step 3 and the alarm LED will be OFF.        |         |

| Procedure |                  | Display |
|-----------|------------------|---------|
| 3         | Initial display. |         |

■ Manual Clock Adjustment by Setting o4-17 to 1

The following actions are possible in the Clock Adjustment Mode:

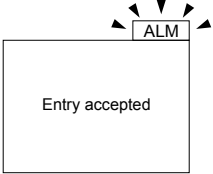
- Set the current time
- Check the time set to the drive Real-Time Clock

Table 4.7 illustrates how to set the Real-Time Clock manually.

Table 4.7 Manual Clock Adjustment Procedure by Setting o4-17 to 1

| Procedure |  | Display |
|-----------|--|---------|
| 1         | The “Clock Not Set” display will appear if the Real-Time Clock data is not entered within 30 seconds of power-up of a drive with an HOA operator that has not yet been set.            |         |
| 2         | Use the up and down arrow keys to scroll through display menu until the screen shows “Programming”.  |         |
| 3         | Press the ENTER key to enter select the parameter setting mode.  |         |
| 4         | Use the up and down arrow keys to scroll through display menu until parameter o4-17 appears.   |         |
| 5         | Press the ENTER key until “0” flashes.   |         |
| 6         | Press the up arrow key so that the display changes to “1”.   |         |
| 7         | Press the ENTER key and the time setting screen will appear. Use the right arrow key to select the desired digit, then set the correct date and time using the up and down arrow keys. |         |

## 4.6 Using the Optional HOA Keypad

| Procedure |  | Display   |
|-----------|--|---|
| 8         | After entering the correct time, press the ENTER key to save the changes.<br>The display will return to the display shown in step 5 and the alarm LED will be OFF. |  |

### ■ o4-17: Real-Time Clock Setting (Resetting RTC to Factory Default)

| No. (Addr. Hex) | Name                      | Description  | Values                      |
|-----------------|---------------------------|--|-----------------------------|
| o4-17 (3100)    | Set/Reset Real-time Clock | Sets the current date and time for the Real-Time Clock.<br>0: — — No Setting<br>1: Real-Time Clock Set<br>2: Real-Time Clock Reset | Default: 0<br>Range: 0 to 2 |

#### Setting 0: — —

No Setting (Default)

#### Setting 1: Set

The digital operator will show the Clock Adjustment display. In Clock Adjustment Mode the user can adjust the Real-Time Clock.

#### Setting 2: Reset

The Real-Time Clock data is cleared. A Clock Not Set alarm will occur until o4-17 is set to 1 and the Real-Time Clock is set.



◆ Menu Structure for HOA Keypad

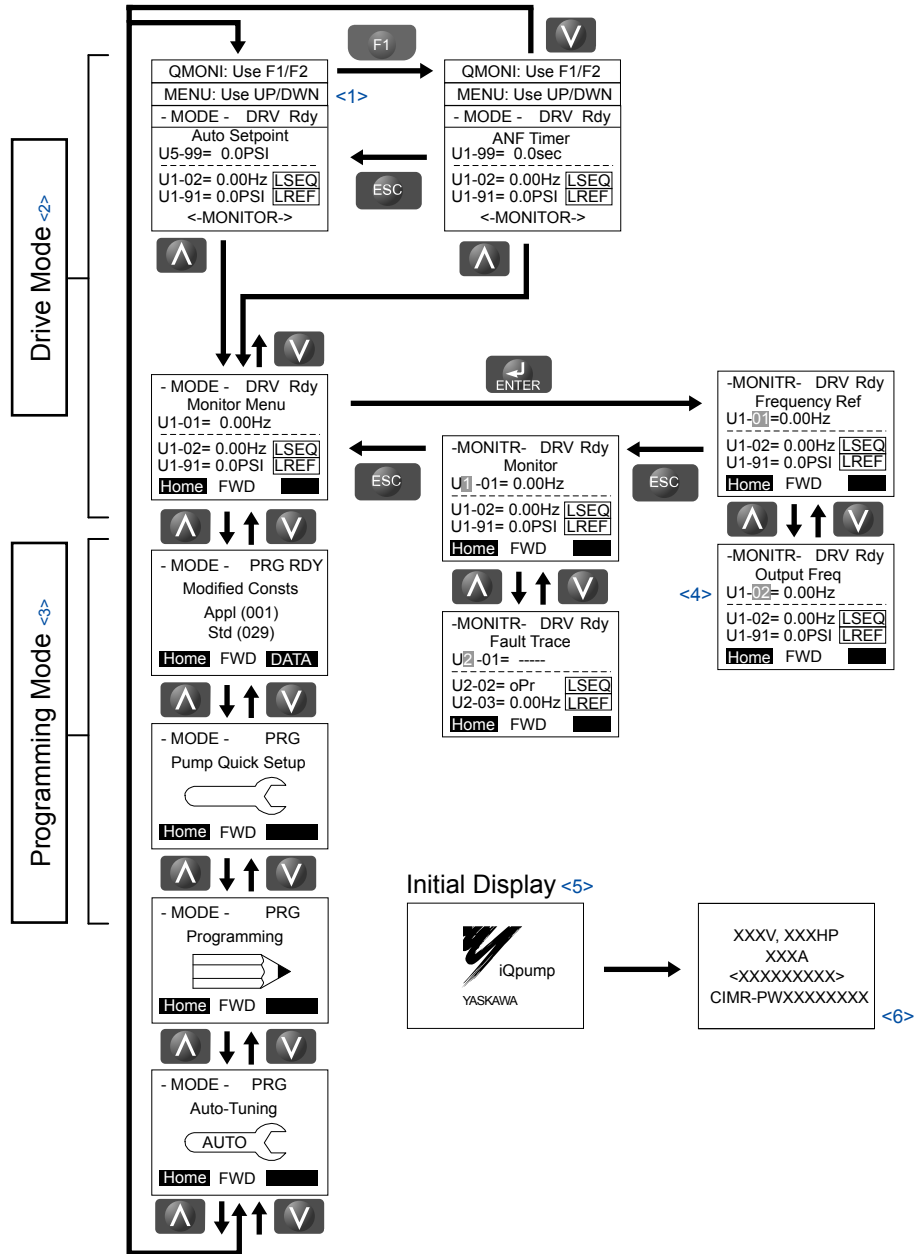


Figure 4.9 HOA Keypad Menu and Screen Structure

- <1> The display cycles between these three displays on the initial startup screen and the Quick Monitor screens.
- <2> Pressing “AUTO” or “HAND” will start the motor.
- <3> Drive cannot operate motor.
- <4> Flashing characters are shown with white letters on gray background. (Example: 0 )
- <5> The Frequency Reference appears after the initial display that shows the product name.
- <6> The information that appears on the display will vary depending on the drive model.

## 4.6 Using the Optional HOA Keypad

### ■ Home Quick Monitor Display (Optional HOA Keypad)

The Home Quick Monitor provides an easily accessible preset group of monitors that are frequently used during operation.

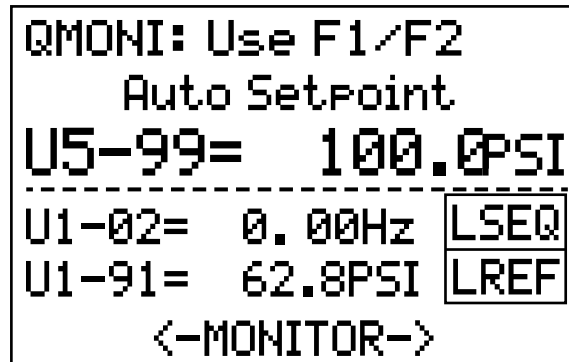


Figure 4.10 Home Quick Monitor Screen

The following monitors are available via the Quick Monitor:

| Monitor | Name                  | Monitor | Name                   |
|---------|-----------------------|---------|------------------------|
| U1-01   | Frequency Reference   | U1-11   | Output Terminal Status |
| U5-99   | Auto Setpoint         | U1-13   | Terminal A1 Level      |
| U1-02   | Output Frequency      | U1-14   | Terminal A2 Level      |
| U1-03   | Output Current        | U1-25   | CPU 1 SW Number        |
| U1-06   | Output Voltage        | U4-01   | Drive Elapsed Time     |
| U1-07   | DC Bus Voltage        | U9-02   | iQ Network Activity    |
| U1-08   | Output Power          | U1-99   | Anti-No-Flow Timer     |
| U1-10   | Input Terminal Status |         |                        |

### ◆ Changing Parameter Settings or Values

This example explains changing C1-02 (Deceleration Time 1) from 10.0 seconds (default) to 20.0 seconds.

**Note:** During serial communication writing, if a parameter change is also attempted via the HOA keypad, a “BUSY - WRITE PROTECTED” message will display. Parameter change will not be possible from the HOA keypad until an Enter command is received via the serial communication to finish the serial writing process.

| Step  | Display/Result |
|---|----------------|
| 1. Turn on the power to the drive. The initial display appears. |                |
| 2. Press  or  until the Parameter Setting Mode screen appears.  |                |
| 3. Press  to enter the parameter menu tree.                     |                |
| 4. Press  or  to select the C parameter group.                  |                |

| Step |  | Display/Result |
|------|--|----------------|
| 5.   | Press  two times.  |                |
| 6.   | Press  or  to select parameter C1-02.  |                |
| 7.   | Press  to view the current setting value (10.0 s). The leftmost digit flashes. |                |
| 8.   | Press  or  until the desired number is selected. "1" flashes.                  |                |
| 9.   | Press  and enter 0020.0.   |                |
| 10.  | Press  to confirm the change.  |                |
| 11.  | The display automatically returns to the screen shown in Step 6.               |                |
| 12.  | Press  as many times as necessary to return to the initial display.            |                |

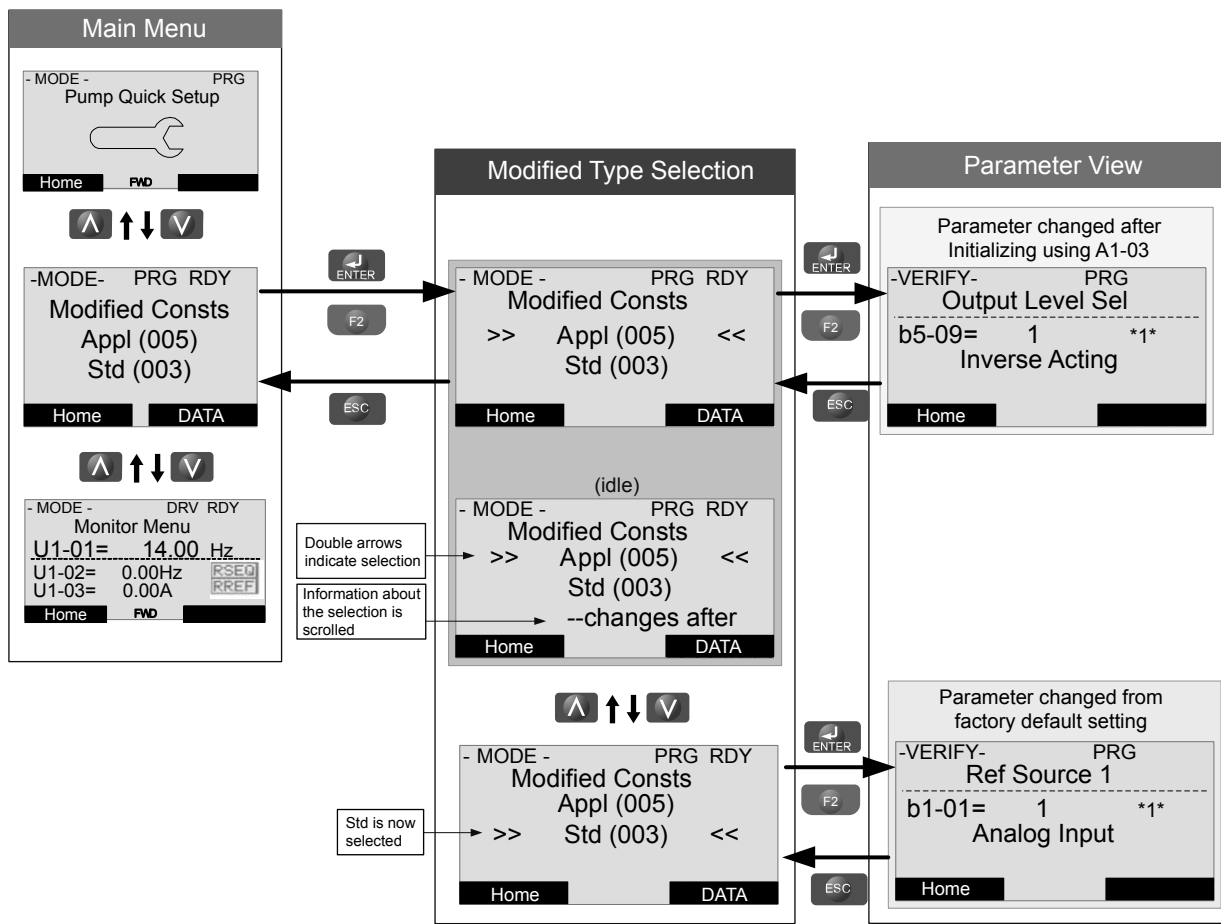
### ◆ Verifying Parameter Changes: Modified Constants Menu

The Modified Constants Menu lists parameter changes as a result of using an Application Preset (A1-03) or by making manual parameter changes (including Auto-Tuning). The Application Preset changes are contained in the (Appl) folder while all other changes appear in the (Std) folder. The Modified Constants Menu helps determine which settings have been changed, and is particularly useful when replacing a drive. If no settings have been changed in either folder, the Modified Constants folders will read "None Modified". The Modified Constants Menu also allows users to quickly access and re-edit any parameter settings that have been changed.

**Note:** The Modified Constants Menu will not display parameters from the A1 group (except for A1-02) or E5-01 even if those parameters have been changed from their default settings.






The following example details where the drive was initialized to Pump Down Mode (A1-03 = 6009) and then three additional parameters were changed including the deceleration time. The example shows how to then change the deceleration time from 14.0 s to 24 seconds.

## 4.6 Using the Optional HOA Keypad



Steps to change parameter C1-02, Deceleration Time, from 14.0 to 24.0 seconds:

| Step |  | Display/Result  |
|------|--|---|
| 1.   | Turn on the power to the drive. The initial display appears.   | <pre> - MODE - DRV Rdy Auto Setpoint U5-99= 0.0PSI ----- U1-02= 0.00Hz LREF U1-91= 0.0PSI LREF &lt;-MONITOR-&gt;                     </pre> |
| 2.   | Press <b>▲</b> or <b>▼</b> until the display shows the top of the Modified Constants Menu.   | <pre> - MODE - PRG RDY Modified Consts Appl (005) Std (003) ----- Home FWD DATA                     </pre>                                  |
| 3.   | Press <b>ENTER</b> then <b>▼</b> to select standard (Std) parameters that have been edited from their original default settings.   | <pre> - MODE - PRG Modified Consts Appl (005) &gt;&gt; Std (003) &lt;&lt; ----- Home FWD DATA                     </pre>                    |
| 4.   | Press <b>ENTER</b> to enter the list of standard parameters that have been edited from their original default settings.<br>If parameters other than C1-02 have been changed, use <b>▲</b> or <b>▼</b> to scroll until C1-02 appears. | <pre> - VERIFY - PRG Rdy Accel Time 1 ----- C1-02 = 14.0sec (0.0-6000.0) "10.0sec" ----- Home FWD                     </pre>                |
| 5.   | Press <b>ENTER</b> to access the setting value. Left digit flashes.  | <pre> - VERIFY - PRG Rdy Accel Time 1 ----- C1-01= 14.0sec (0.0-6000.0) "10.0sec" ----- Home FWD                     </pre>                 |

| Step |   |   | Display/Result  |
|------|---|---|---|
| 6.   | Press  or  until the desired number is selected. "1" flashes. | → | <pre> -PRMSET- PRG Decel Time 1 ----- C1-02=0014.0sec (0.0~6000.0) "10.0 sec" Home FWD →                     </pre>                             |
| 7.   | Press  and enter 0024.0.   | → | <pre> -PRMSET- PRG Decel Time 1 ----- C1-02=0024.0sec (0.0~6000.0) "10.0 sec" Home FWD →                     </pre>                             |
| 8.   | Press  to confirm the change.  | → | <div style="border: 1px solid black; padding: 5px; text-align: center;">Entry Accepted</div>  |
| 9.   | The display automatically returns to the screen shown in Step 4.  | → | <pre> -PRMSET- PRG Decel Time 1 ----- C1-02= 24.0sec (0.0~6000.0) "10.0 sec" Home FWD DATA                     </pre>                           |
| 10.  | Press  as many times as necessary to return to the initial display.  | → | <pre> - MODE - DRV Rdy Auto Setpoint U5-99= 0.0PSI ----- U1-02= 0.00Hz [LSEQ] U1-91= 0.0PSI [LREF] &lt;-MONITOR-&gt;                     </pre> |

## 4.7 Pump Application Presets

The following sections list the parameters affected by the different Application Presets.

### ◆ Parameters Set Depending on A1-03 Setting

The following table shows the parameters that are set depending on the A1-03 initialization:

| A1-03 = 6008<br>(A1-06 = 8)<br>Pressure Control |       | A1-03 = 6009<br>(A1-06 = 9)<br>Pump Down Level |       | A1-03 = 7770<br>(A1-06 = 1)<br>General Purpose |           | A1-03 = 7771<br>(A1-06 = 2)<br>Sub Mtr GP Oper |          |
|---|-------|--|-------|--|-----------|--|----------|
| Parameter                                       | Value | Parameter                                      | Value | Parameter                                      | Value     | Parameter                                      | Value    |
|   |       | b5-09  | 1     | b1-01  | 1         | b5-01  | 0        |
|   |       | b5-39  | 2     | b1-02  | 1         | H1-06  | 4        |
|   |       | P1-02  | 6     | b5-01  | 0         | H1-07  | 0        |
|   |       | P2-01  | 2     | C1-01  | 25.0 sec  | H2-02  | 0        |
|   |       | P2-23  | 0.00% | C1-02  | 25.0 sec  | H2-03  | A        |
|   |       |  |       | H1-06  | 4         | o1-06  | 0        |
|   |       |  |       | H1-07  | F         | P1-05  | 0 sec    |
|   |       |  |       | H2-02  | 0         | d1-01  | 40.00 Hz |
|   |       |  |       | H2-03  | A         |  |          |
|   |       |  |       | H3-02  | 0         |  |          |
|   |       |  |       | H3-10  | 2         |  |          |
|   |       |  |       | L5-01  | 0         |  |          |
|   |       |  |       | L5-04  | 180.0 sec |  |          |
|   |       |  |       | o1-06  | 0         |  |          |
|   |       |  |       | P1-05  | 0 sec     |  |          |
|   |       |  |       | P1-06  | 0.0 Hz    |  |          |
|   |       |  |       | P4-12  | 0.0 Hz    |  |          |
|   |       |  |       | P4-17  | 0.0 min   |  |          |
|   |       |  |       | P5-02  | 0.0 Hz    |  |          |

### ◆ Parameters Displayed Depending on A1-06 Setting

The following table shows which parameters are shown on the Pump Quick Setup menu depending on the A1-06 selection:

| A1-03 = 6008<br>(A1-06 = 8)<br>Pressure Control | A1-03 = 6009<br>(A1-06 = 9)<br>Pump Down Level | A1-03 = 7770<br>(A1-06 = 1)<br>General Purpose | A1-03 = 7771<br>(A1-06 = 2)<br>Sub Mtr GP Oper |
|---|--|--|--|
| E2-01   | E2-01  | b1-01  | E2-01  |
| E2-04   | E2-04  | b1-02  | E2-04  |
| P1-03   | P1-02  | C1-01  | d1-01  |
| Q1-01   | P1-03  | C1-02  | P1-06  |
| P1-04   | Q1-01  | E2-01  | P4-10  |
| P1-06   | P1-04  | E2-04  | P5-04  |
| P4-10   | P1-06  | L5-01  |  |
| P5-04   | P2-02  | L5-04  |  |
|   | P4-10  | P1-06  |  |
|   | P5-04  |  |  |

## 4.8 iQpump Presets and Functions

Table 4.8 iQpump Presets and Functions

| Feature Name                                | Preset or Function | Page |
|---|--------------------|------|
| Pump Down Level Control                     | Preset             | 87   |
| General Purpose Mode                        | Preset             | 89   |
| Low City or Low Suction Inlet Pressure      | Function           | 90   |
| Current Limit                               | Function           | 91   |
| Speed Follower Deceleration Time Switchover | Function           | 92   |
| Software (MEMOBUS) Multiplexing Setup       | Function           | 93   |
| Simple Duplex System Application            | Function           | 97   |
| Multiplexing Stop History                   | Function           | 100  |

### ◆ iQpump Presets

#### ■ Pump Down Level Control Application Preset

This preset allows the drive to regulate the depth of water in a tank or other vessel that is being filled by an external source. A feedback device that measures water depth is wired to the drive. A PI-control process loop will then modulate the pump speed to pump water out the tank to keep the water depth the setpoint level (pump out at the recharge rate). The drive controller has an application preset to simplify the start up and control of this application.

- System units are in feet (P1-02 = 6).
- Feedback device scaling (P1-03). The feedback device scaling must be entered into the drive for proper control.
- Minimum pump speed (P1-06). Most pumps cannot be run below a certain speed or cavitation can occur.
- Number of Motor Poles (E2-04). The default is for a 2-pole motor.
- Sleep Function. The drive controller will sleep when the system demand is low and awaken when demand returns.

#### Required Control Wiring

Most depth level transducers have current-based feedback (4-20 mA). The A2 terminal of the drive is preset for 4-20 mA and pre-programmed for PID feedback (H3-10 = B).

#### Start Up Procedure

1. Set parameter A1-03 to 6009 (Pump Down Level) to pre-set parameter values for this application.
2. Set the motor-rated current in parameter E2-01. This information can be found on the motor nameplate or specification sheet.
3. Set the number of motor poles in parameter E2-04 (2-pole motors have a rated RPM of slightly less than 3600 RPM; 4-pole motors have a rated RPM of slightly less than 1800 RPM). This information can be found on the motor nameplate or specification sheet.
4. Set the feedback device scaling in parameter P1-03. Check the sensor nameplate or specification sheet. For example, if the device outputs 20 mA at 14.50 ft of water depth, the set P1-03 to 14.50. The drive controller will automatically scale all associated parameters and monitors. Monitor U1-91 (Pump Feedback) will display the measured water depth in feet. The drive has a High Feedback Fault set in parameter P1-11. Make sure that P1-11 is appropriately set for sensor scaling in P1-03.
5. Set the desired water depth level in parameter Q1-01 (PID setpoint). This is desired water depth that the drive will regulate the pump speed around. To quickly access this parameter, press the HOME key and then the ENTER key. The U1-99 monitor on the home screen displays the Q1-01 PID setpoint.
6. Set the minimum speed that the pump can be run in parameter P1-06. The default is 40 Hz. This information can be found on the pump specification sheet.
7. The default setting does not allow the drive to automatically restart after power loss if the drive was running at the time of power loss. Set P4-10, AUTO Mode Operator Run Power Down Storage, to 1 to enable this feature.
8. Press the AUTO key to start the drive with PID control (water depth control). Press the OFF key to stop the drive.
9. The pump can be run in HAND (LOCAL) mode for maintenance purposes by pressing the HAND key while the drive is stopped. The HAND key acts as a start button. Press the OFF button to stop the drive. Press AUTO to return the drive to PID control. The HAND speed reference can be set in P5-02 (Hand Reference 1). Disable the HAND key by setting P5-04 to 0 (disabled).
10. Configure the sleep function. The pump can be programmed to shut off or "sleep" if the water falls below the depth set in parameter P2-02 (Sleep Level). The controller will monitor the water depth feedback signal and wake up when the water depth rises above the setting in parameter P1-04 (Start/Draw Down Level). Logically, set the Sleep Level

## 4.8 iQpump Presets and Functions

(P2-02) lower than the PID setpoint and set the Draw Down Level (P1-04) slightly above the PID setpoint to prevent the drive from waking up until the water exceeds the desired depth setting. Sleeping helps the drive save energy and mechanical wear. When P1-04 is set to 0 (default), the sleep function is disabled.

### Related Parameters

| No.   | Parameter Name                            | Setting Values   |
|-------|---|--|
| A1-01 | Access Level Selection                    | Default: 2<br>Range: 0 to 3  |
| A1-03 | Initialize Parameters                     | Default: 0<br>Range: 0 to 5550; 6008, 6009, 7770, 7771   |
| E2-01 | Motor Rated Current                       | Default: Depends on o2-04<br>Min.: 10% of drive rated current<br>Max.: 200% of drive rated current |
| E2-04 | Number of Motor Poles                     | Default: 2<br>Min.: 2<br>Max.: 48  |
| P1-03 | Feedback Device Scaling                   | Default: 145.0 PSI<br>Min.: 0.1<br>Max.: 6000.0  |
| P1-11 | High Feedback Level                       | Default: 155.0 PSI<br>Min.: 0.0<br>Max.: 6000.0  |
| P1-06 | Minimum Pump Speed                        | Default: 40.0 Hz<br>Min.: 0.0<br>Max.: [E1-04]   |
| P1-04 | Start / Draw Down Level                   | Default: 0.0 PSI<br>Min.: -999.9<br>Max.: 999.9  |
| P2-02 | Sleep Level                               | Default: 0.0 Hz<br>Min.: 0.0<br>Max.: 6000.0   |
| P4-10 | AUTO Mode Operator Run Power Down Storage | Default: 0<br>Range: 0, 1  |
| P5-02 | HAND Speed Reference 1                    | Default: 40.0 Hz<br>Min.: 0<br>Max.: [E1-04]   |
| P5-04 | HAND Key Function Selection               | Default: 1<br>Range: 0, 1  |
| Q1-01 | PID Controller Setpoint 1                 | Default: 0.0<br>Min.: 0.0<br>Max.: 6000.0  |
| U1-99 | Anti-No-Flow Timer                        | No signal output available   |



## ■ General Purpose Mode Application Preset

The purpose of this mode is to allow the drive controller to run a motor at a set speed without the PID process loop. This preset is designed to simplify using the drive for applications other than pumping control. The default settings call for the frequency reference to be an analog input and the run command to come from the terminal strip via a maintain contact closure. The PID loop is disabled and no process feedback is required.

### Required Control Wiring

No additional control wiring is required when the drive controller is at its default settings.

### Start Up Procedure

1. Set parameter A1-03 to 7770 (General Purpose Mode) to pre-set parameter values for this application.
2. Set the source of the frequency reference for the drive controller in parameter b1-01. The default setting is from the terminal strip via a 0 to 10 V analog signal wired into terminal A1.
3. Set the source of the Run Command for the drive controller in parameter b1-02. The default setting is from the terminal strip via a maintained contact closure.
4. Set the Acceleration Time of the motor in parameter C1-01. This is the time to accelerate the motor from zero speed to 60 Hz (E1-04, Maximum Output Frequency).
5. Determine the stopping method of the motor. The default setting is coast to stop. To ramp the motor to a stop, set b1-03 to 0 and then set the motor deceleration time in parameter C1-02. This is the time to stop the motor from to 60 Hz (E1-04, Maximum Output Frequency) to zero speed.
6. Set the motor-rated current in parameter E2-01. This information can be found on the motor nameplate or specification sheet.
7. Set the number of motor poles in parameter E2-04 (2-pole motors have a rated RPM of slightly less than 3600 RPM; 4-pole motors have a rated RPM of slightly less than 1800 RPM). This information can be found on the motor nameplate or specification sheet.
8. Determine whether the drive controller should attempt to reset itself after a fault. The default setting is disabled. The function is turned on by setting 1 to 10 reset attempts in parameter L5-01 and the time between each reset in parameter L5-04.
9. Set the minimum speed at which the motor can run in parameter P1-06. If the system has a minimum safe operation speed, set it in P1-06. This will act as a lower limit of the frequency reference.
10. The motor can be run in HAND (LOCAL) Mode for maintenance purposes by pressing the HAND key while the drive is stopped. The HAND key acts as a start button. Press the OFF button to stop the drive. Set P5-04 to 0 to disable the HAND key. The default frequency reference is 0.0 Hz in HAND Mode. This can be changed in parameter P5-02. The AUTO key has no effect with the default settings in the General Purpose Application Preset.

### Related Parameters

| No.   | Parameter Name                  | Setting Values   |
|-------|---------------------------------|--|
| A1-03 | Initialize Parameters           | Default: 0<br>Range: 0 to 5550; 6008, 6009, 7770, 7771   |
| b1-01 | Frequency Reference Selection 1 | Default: 0<br>Range: 0 to 4  |
| b1-02 | Run Command Selection 1         | Default: 0<br>Range: 0 to 3  |
| b1-03 | Stopping Method Selection       | Default: 1<br>Range: 0 to 3  |
| C1-01 | Acceleration Time 1             | Default: 20.0 s<br>Min.: 0.0<br>Max.: 6000.0   |
| C1-02 | Deceleration Time 1             | Default: 10.0 s<br>Min.: 0.0<br>Max.: 6000.0   |
| E1-04 | Maximum Output Frequency        | Default: 60.0 Hz<br>Min.: 40.0<br>Max.: 400.0  |
| E2-01 | Motor Rated Current             | Default: Depends on o2-04<br>Min.: 10% of drive rated current<br>Max.: 200% of drive rated current |
| E2-04 | Number of Motor Poles           | Default: 2<br>Min.: 2<br>Max.: 48  |

## 4.8 iQpump Presets and Functions

| No.   | Parameter Name                  | Setting Values                                 |
|-------|---------------------------------|--|
| L5-01 | Number of Auto Restart Attempts | Default: 5<br>Min.: 0<br>Max.: 10              |
| L5-04 | Fault Reset Interval Time       | Default: 20.0 s<br>Min.: 10.0<br>Max.: 3600.0  |
| P1-06 | Minimum Pump Speed              | Default: 40.0 Hz<br>Min.: 0.0<br>Max.: [E1-04] |
| P5-02 | HAND Reference                  | Default: 40.0 Hz<br>Min.: 0<br>Max.: [E1-04]   |
| P5-04 | HAND Key Function Selection     | Default: 1<br>Range: 0, 1                      |

### ◆ iQpump Functions

#### ■ Low City or Low Suction Inlet Pressure

This function is used with low suction inlet pressure switches on pressure booster systems for buildings that get their main water supply from a municipality. This pressure switch enables and disables the pump system when the inlet supply is at a low demand and when running the pump system in this condition will cause damage.

An inlet pressure switch is wired directly into the drive using one of the digital input terminals. If the pressure switch is active and sufficient pressure is available, the drive system will operate normally. If the pressure switch indicates that incoming pressure is too low, the drive will take the following actions:

- The drive will be forced into a sleep-like state (coast to stop).
- Any drives staged in multiplex mode will immediately coast to stop.
- The selected alarm “Low City Pressure”, “Low Suction Pressure”, or “Low Water In Tank” will be displayed (determined by P4-24).

All drives will restart when sufficient pressure returns.

#### Required Control Wiring

Any one of the multi-function digital inputs (S1 to S7) must be wired and programmed with a low suction inlet pressure switch. The appropriate terminal parameter (H1-□□) must be set to 73 (Low City Pressure). The action of the switch (normally open / normally closed) is set in parameter P4-21.

#### Start Up Procedure

1. Set all other parameters required for the application such as PID control loop, sleep, motor, and I/O parameters.
2. Set one digital input for the low suction inlet pressure switch (H1-□□ = 73). Wire the switch to this terminal.
3. Configure the terminal for a normally open / closed switch type using parameter P4-21.
4. Configure the delay times for activating and removing the alarm in parameters P4-23 and P4-24. This can be used to stop the drive from frequent cycling when pressure varies greatly.
5. Select the alarm message that will be displayed when a Low City condition is detected using parameter P4-24. Options include “Low Cty Pressure”, “Low Suction Pres”, and “Low Watr In Tank”.

#### Related Parameters, Faults, and Alarms

| No.   | Parameter Name          | Setting Values                         |
|-------|-------------------------|--|
| P4-21 | Low City Input Select   | Default: 1<br>Range: 0, 1              |
| P4-22 | Low City On-Delay Time  | Default: 10 s<br>Min.: 1<br>Max.: 1000 |
| P4-23 | Low City Off-Delay Time | Default: 5 s<br>Min.: 0<br>Max.: 1000  |
| P4-24 | Low City Alarm Text     | Default: 0<br>Range: 0 to 2            |

| H1 Multi-Function Digital Input Settings |                |  |
|--|----------------|--|
| H1-□□ Setting                            | Function       | Description  |
| 73                                       | Low City Press | Indicates that sufficient or insufficient pressure is present on the inlet to the pump. Used mainly for pressure booster situations. |

| Digital Operator Display   | Minor Fault Name   |
|--|--|
| Low City Pressure (LCP)  | Low City Pressure  |
| Cause  | Possible Solution  |
| Insufficient pressure is present on the inlet to the pump.<br>Shown when P4-24 = 0 and when the digital input has been active (closed for P4-21 = 0, or open for P4-21 = 1) for the time set in P4-22. | <ul style="list-style-type: none"> <li>• Check pressure switch contact for correct operation.</li> <li>• Check control wiring to drive terminal strip from pressure switch contact.</li> <li>• Check to make sure that suction pressure is present by means of a separate measuring device.</li> </ul> |

| Digital Operator Display                  | Minor Fault Name  |
|---|---|
| Low Suction Pressure (LSP)                | Low Suction Pressure  |
| Cause                                     | Possible Solution   |
| Insufficient suction pressure is present. | Shown when P4-24 = 1 and when the digital input has been active (closed for P4-21 = 0, or open for P4-21 = 1) for the time set in P4-22.<br>The drive, if running, coasts-to-stop and does not run until the digital input has been inactive for the time set in P4-22. |

| Digital Operator Display  | Minor Fault Name   |
|---|--|
| Low Water in Tank (LWT)   | Low Water in Tank  |
| Cause   | Possible Solution  |
| The water level in the tank is too low.<br>Shown when P4-24 = 2 and when the digital input has been active (closed for P4-21 = 0, or open for P4-21 = 1) for the time set in P4-22. | <ul style="list-style-type: none"> <li>• Check pressure switch contact for correct operation.</li> <li>• Check control wiring to drive terminal strip from pressure switch contact.</li> <li>• Check to make sure that suction pressure is present by means of a separate measuring device.</li> <li>• Raise the water level.</li> </ul> |

### ■ Current Limit

This function provides a current limit of the pump (motor). The function is designed to prevent long-term overload conditions of the pump, especially if the motor and drive are oversized compared to the pump. The drive will attempt to limit the output current by reducing the frequency reference. The frequency is reduced using an internal current PID regulator. When the Current Limit function is active, the alarm "Current Limit Foldback" or "CUr" will be displayed on the digital operator keypad. This function will only operate correctly when the drive is connected to a variable torque motor load such as a centrifugal pump. More specifically, it will only operate if the load is such that output current increases as output frequency increases (and vice-versa). The current limit function reduces the pump speed to just above the lower value between the minimum pump speed (P1-06) or the minimum output frequency. If PID mode is enabled (b5-01 > 0), a special limit will be applied to the PID integrator when output current limit is active to prevent integrator wind-up.

Current Limit Foldback

(CUr)

#### Start Up Procedure

1. Set all other parameters required for the application such as PID control loop, sleep, motor, and I/O parameters
2. Turn on the current limit function by setting Q3-01 to 1 (enabled). The default setting is 0 (disabled).
3. Set the desired current limit in Q3-02. This value should not exceed the motor, pump or drive ratings. This does not change the motor (oL1) or drive (oL2) overload functions.
4. If desired, program a multi-function digital output (H2-□□) to 89 (Output Current Limit) to annunciate the alarm.

#### Related Parameters

| No.   | Parameter Name              | Setting Values                              |
|-------|-----------------------------|---|
| Q3-01 | Output Current Limit Select | Default: 0<br>Range: 0, 1                   |
| Q3-02 | Current Limit               | Default: 0.0 A<br>Min.: 0.0<br>Max.: 1000.0 |

## 4.8 iQpump Presets and Functions

| H2 Multi-Function Digital Output Settings |                |   |
|---|----------------|---|
| H2-□□ Setting                             | Function       | Description   |
| 89  | Output I Limit | Closed: Drive output speed is being limited due to the output current limit or the single phase foldback regulator. |

The drive displays a message on the keypad when the drive is in output current limit.

| Digital Operator Display     | Message  |
|------------------------------|--|
| Current Limit Foldback (CUr) | Displayed when drive output speed is being limited due to the output current limit. Reduce the load or replace with higher capacity drive. |

### ■ Speed Follower Deceleration Time Switchover

The iQpump Speed Follower will attempt to match the speed of the Lead Drive after the Lag Drive Fixed Speed Delay.

Consider a scenario wherein the system needs help from an idle drive to maintain system pressure. When the idle drive is called to run, the difference between the setpoint and the feedback may be too small to make the drive accelerate faster. In such cases, the system is configured with these settings:

- Set for Lag Drive Speed Follower
- Add Pump method is Frequency Reference
- Frequency Reference setting close to the maximum frequency

The system will drop the speed after the Lag Drive Fixed Speed Delay expires in order to follow the output frequency of the previously idle drive. This transition may cause unwanted pressure drops. A longer deceleration time will be activated on the lag drives when the system switches the drive that is being followed. The longer deceleration time will be effective for a programmable setting, after which the regular deceleration time is used.

#### Functional Operation

If P9-05 = 3 (Follow Lead Spd), the lag drive will use the network information and the lead drive output speed as its frequency reference. The lag drive final speed reference is affected by (Lag Follower Gain, P9-30) and then by (Lag Follower Bias, P9-31).

Lag Drive Speed = ( Lead Drive Speed x Lag Follower Gain ) + Lag Follower Bias

When P9-33 > 0.0 sec, an alternate deceleration time (Lag Follower Decel, P9-32) is used when the drive switches from the latched speed (Lag Fixed Delay, P9-07) to the new Lead drive output frequency. The deceleration time is active for the duration set in P9-33, Lag Follower Deceleration Time Active Time, and will switch back to the regular deceleration rate when it expires.

**Note:** Parameter functionality stated below only applies when P1-01 = 3 (MEMOBUS Network)

#### Related Parameters

| No.   | Name                                       | Description  | Values  |
|-------|--|--|---|
| P9-05 | Lag Drive Mode                             | Determines the functionality of the lag drives.<br>0: Fixed speed. The drive runs at the P9-06 setting after the time set in P9-07 expires.<br>2: Turn off. The drive stops running when it switches to a lag drive after the time set in P9-07 expires.<br>3: Follow Lead Speed. The drive will follow the speed of the current lead drive, applying P9-30 gain and P9-31 bias. | Default: 0<br>Range: 0, 2, 3                  |
| P9-07 | Lag Fixed Speed Delay                      | Specifies how long speed is latched before performing the function specified in P9-05 when the drive changes from a lead to a lag.   | Default: 5 s<br>Min.: 0<br>Max.: 1000         |
| P9-30 | Lag Drive Speed Follower Gain              | Sets the gain to be applied to the speed of the current lead drive when P9-05 is set to 3. The bias to be applied is set in P9-31.   | Default: 100.0%<br>Min.: 0.0<br>Max.: 300.0   |
| P9-31 | Lag Drive Speed Follower Bias              | Sets the bias to be applied to the speed of the current lead drive when P9-05 is set to 3. The gain to be applied is set in P9-30.   | Default: 0.00 Hz<br>Min.: -60.0<br>Max.: 60.0 |
| P9-32 | Lag Follower Deceleration Time             | Sets the deceleration time when the P9-33 timer is running and the drive is running as Lag Drive Speed Follower (P9-05 is set to 3).   | Default: 60.0 s<br>Min.: 0.0<br>Max.: 1000.0  |
| P9-33 | Lag Follower Deceleration Time Active Time | Sets the time during which the deceleration time set in P9-32 is effective. The drive will use the standard deceleration rate when it expires. Setting this parameter to 0.0 disables the function.  | Default: 0.0 s<br>Min.: 0.0<br>Max.: 360.0    |

| No.   | Name                            | Description  | Values                      |
|-------|---------------------------------|--|-----------------------------|
| P9-99 | Network Compatibility Selection | Determines the communication compatibility for the iQPump MEMOBUS network.<br>0: A-Ver: 30034<br>1: B-Ver: 30035/36<br>2: iQ Smart Network | Default: 2<br>Range: 0 to 2 |

## ■ Software (MEMOBUS) Multiplexing Setup

### Wiring the Drive RS-485 Network Connections

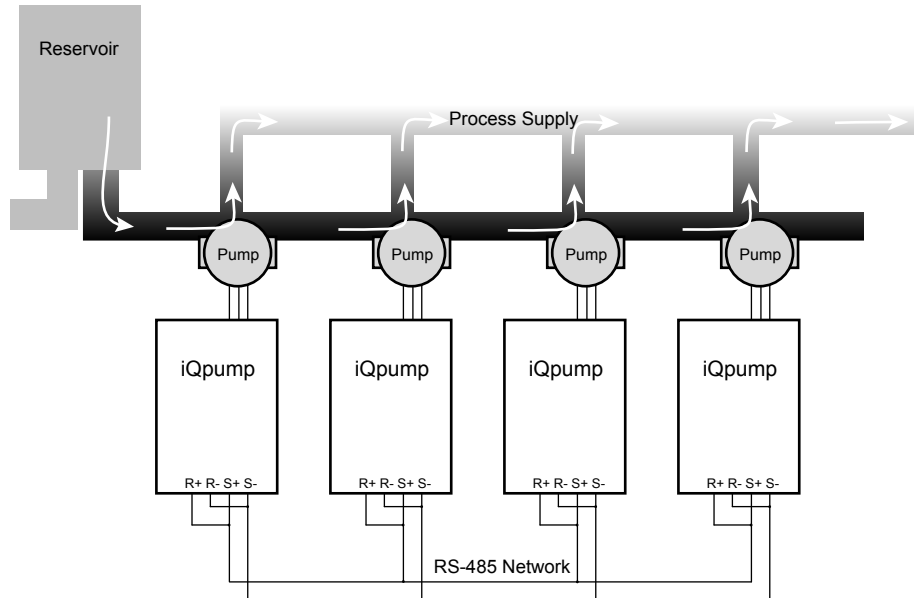


Figure 4.11 System Overview

Perform the following steps to make the RS-485 network connections between all drives that will be multiplexed:

1. Jumper terminals (R+ to S+) and jumper terminals (R- to S-) terminals on each individual drive according to [Figure 4.12](#).

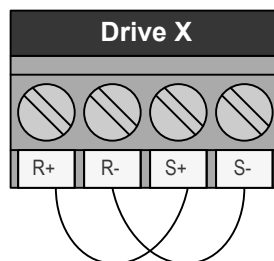


Figure 4.12 Drive Terminal Jumpers

2. Use shielded communication cable for steps 3 and 4 to connect the drives in a daisy chain manner according to [Figure 4.13](#).
3. Daisy chain the (R+ to S+) terminals between each drive.
4. Daisy chain the (R- to S-) terminals between each drive.

## 4.8 iQpump Presets and Functions

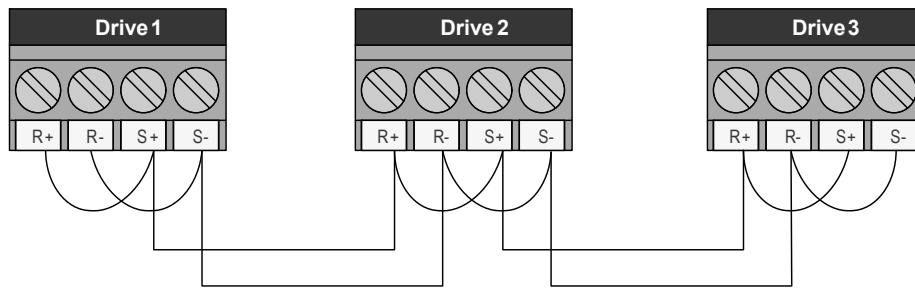


Figure 4.13 Daisy Chain Three Drives

### Setting the Drive Networking Parameters

1. Set parameter H5-01, Serial Node Address, on each drive.

**Note:** For optimal performance, use consecutive numbers starting from 1. Parameter setting H5-01 must be unique for each drive.

2. Set parameter P9-25, Highest Node Address, on each drive.

**Note:** For optimal performance, set to highest H5-01 value. This setting must be the same for all the drives on the network.

3. Set P1-01 to 3 (MEMOBUS/Modbus Network) on all the drives.

4. Cycle main power to all networked drives.

**Note:** The H5-01 setting will not take effect until power is cycled to the drive and may cause communication errors and unexpected behavior.

### Verifying Drive Network Communications

Access monitor U9-02, Network Activity, and verify:

- No drives have a value of 0 <->
- All drives are receiving valid data indicated by a regular change in the monitor value.
- At least one drive has the unit <M>, while the others have the unit <+>.

Table 4.9 Network Connectivity Information

| Network State  | Top Line on Home Screen<br>(o1-12 = 1)  | U9-02 Network Activity   |
|--|---|--|
| Drive is the Master and is communicating with another drive.       | <pre> &lt;M&gt; CONNECTED Pump Off Network U5-99= 100.0PSI U1-02= 0.00Hz [LSEQ] U1-91= 62.8PSI [LREF] &lt;- MONITOR -&gt;                     </pre>    | <pre> - MONITR -      DRV RDY   Network Activity U9-02= 9453&lt;M&gt; U1-02= 0.00Hz [LSEQ] U1-91= 62.8PSI [LREF] Home           FWD                     </pre> |
| Drive is a node on the network and is communicating with a Master. | <pre> &lt;+&gt; CONNECTED Pump Off Network U5-99= 100.0PSI U1-02= 0.00Hz [LSEQ] U1-91= 62.8PSI [LREF] &lt;- MONITOR -&gt;                     </pre>    | <pre> - MONITR -      DRV RDY   Network Activity U9-02= 324&lt;+&gt; U1-02= 0.00Hz [LSEQ] U1-91= 62.8PSI [LREF] Home           FWD                     </pre>  |
| Drive is not able to communicate to any other drives.              | <pre> &lt;-&gt; DISCONNECTED Pump Off Network U5-99= 100.0PSI U1-02= 0.00Hz [LSEQ] U1-91= 62.8PSI [LREF] &lt;- MONITOR -&gt;                     </pre> | <pre> - MONITR -      DRV RDY   Network Activity U9-02= 0&lt;-&gt; U1-02= 0.00Hz [LSEQ] U1-91= 62.8PSI [LREF] Home           FWD                     </pre>    |

If a drive displays U9-02 = 0 <->:

- Check physical connections.
- Verify the H5-□□ serial communication settings.
- Confirm the P9-25 and P9-27 settings on all the drives. P9-25 should be set to the highest H5-01 address and at least one drive should have P9-27 set to 0.
- Cycle main power.

**Multiplexing Principle**

Always observed by system:

- New drives start as Lead and run in PID mode.
- Only the Lead drive can request staging and de-staging.
- Staging will start a new Lead drive and make the old Lead drive into a Lag drive.
- De-staging will stop the current Lead drive and restore the previous drive as the Lead drive.

**Multiplexing Messages**

During multiplexing, the drive will display a message when it will be staged in or de-staged out. The message will indicate if it is being staged in or out and display a countdown timer of how long until the change takes place.

One of the following conditions must be met for de-staging to occur:

- High Feedback Quick De-stage
- Low Feedback Quick De-stage
- Normal De-stage
- Low Water Level De-stage
- Suction Pressure De-stage

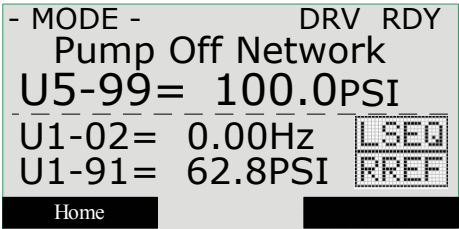
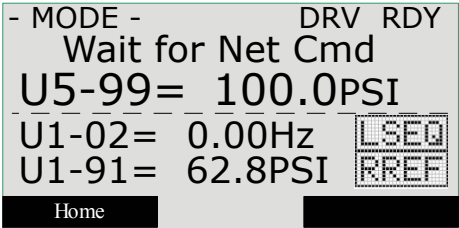
**Drive Run Order**

U9-04, Running Queue No:

- Shows the position in the iQpump MEMOBUS running queue.
- U9-04 = 0 for pumps that are not running.
- U9-04 = 1 on the first pump that came on and is still running.
- U9-04 = 2 on the second pump that came on and is still running.
- U9-04 = the number of pumps running for the current Lead drive.

**Multiplex Status Display**

**Table 4.10 Multiplex Status Display (Optional HOA Keypad, JVOP-183)**

| Network State  | Display  |
|--|--|
| <p>Drive is not able to accept commands from the iQpump MEMOBUS network because the drive is not in AUTO Mode run.</p> |  |
| <p>Drive is in AUTO Mode and waiting for a run command from the iQpump MEMOBUS network.</p>                            |  |

## 4.8 iQpump Presets and Functions

| Network State   | Display |
|---|---------|
| Drive is in AUTO Mode, Lead operation and is currently regulating the system using PID control.   |         |
| Drive is in AUTO Mode, Lag operation and is holding the speed at the time it made the switch from being a lead drive to a lag. Speed is held until P9-07 time expires. The Home screen will display U1-01 instead of U5-99. |         |
| Drive is in AUTO Mode, Lag operation and is running at the speed set in P9-06. The Home Screen will display U1-01 instead of U5-99.   |         |
| Drive is in AUTO Mode, Lag operation and is following the speed of the current Lead drive. The Home screen will display U1-01 instead of U5-99.   |         |

### PID Feedback via Network

The Network PID Feedback comes from a drive on the network with a valid analog PID feedback source and can be used as the primary or secondary feedback source for a networked drive.

Set P9-02 to 0 if a drive has an analog PID feedback device installed and switching to network as a backup is not desired.

If a drive has an analog PID feedback device installed and the network PID feedback is considered as a backup, set P9-02 to 1 for no alarm message when switched and set P9-02 to 2 for an alarm.

Set P9-02 to 3 if a drive has no analog PID feedback device installed and relies solely on the analog PID feedback of another networked drive.

**Note:** Connect an analog PID feedback device to each drive for best performance.

### Related Parameters

| No.   | Parameter Name       | Setting Values                           |
|-------|----------------------|--|
| H5-01 | Drive Node Address   | Default: 1F (Hex)<br>Min.: 0<br>Max.: FF |
| P1-01 | Pump Mode            | Default: 0<br>Range: 0, 3                |
| P9-02 | Feedback Source      | Default: 0<br>Range: 0 to 3              |
| P9-25 | Highest Node Address | Default: 4<br>Range: 2 to 4              |



| No.   | Parameter Name       | Setting Values              |
|-------|----------------------|-----------------------------|
| P9-27 | Network Recovery     | Default: 0<br>Range: 0 to 3 |
| U9-02 | Network Activity     | No signal output available  |
| U9-04 | Running Queue Number | No signal output available  |

### ■ Simple Duplex System Application Example

A customer requires a duplex system with the following capabilities:

- Control the system pressure using two drives (no PLCs).
- Alternate drives everyday to even out the pump wear.
- Toggle switch for Run command.
- Each drive will have its own feedback transducer. Due to the shut-off valves, the network feedback should not be used as a backup.
- Pump is at optimal running speed when at fixed speed of 54.0 Hz.
- Setpoint is 100 PSI, feedback scale is 145 PSI, start level is 80 PSI.

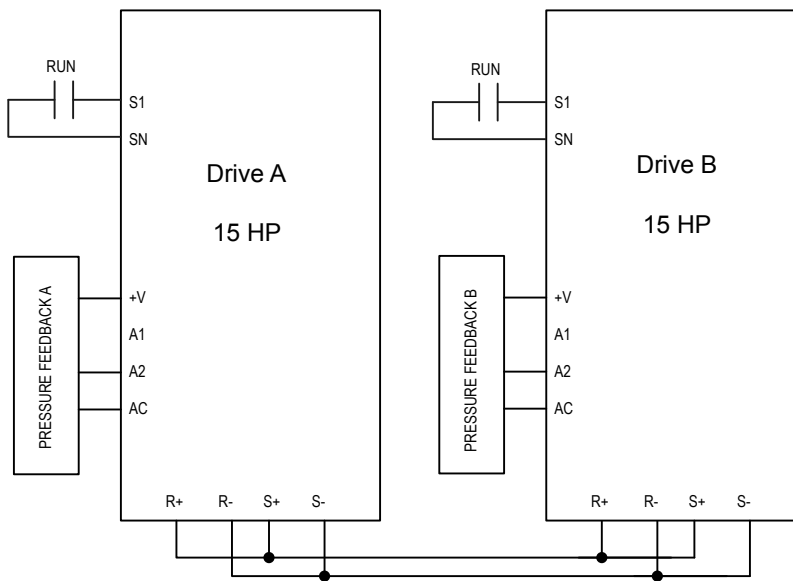


Figure 4.14 Simplified Wiring Diagram

Table 4.11 Related Parameters for Simple Duplex System Example

| Description                 | Drive A <1>     | Drive B <1>     |
|-----------------------------|-----------------|-----------------|
| Run Source: 1 (Terminals)   | b1-02 = 1       | b1-02 = 1       |
| Node Address                | H5-01 = 1       | H5-01 = 2       |
| Highest Node Address        | P9-25 = 2       | P9-25 = 2       |
| Pump Mode: 3 (Network)      | P1-01 = 3       | P1-01 = 3       |
| Feedback Source: 0 (Analog) | P9-02 = 0       | P9-02 = 0       |
| Lag Fixed Speed             | P9-06 = 54.0 Hz | P9-06 = 54.0 Hz |
| Setpoint                    | U5-99 = 100 PSI | U5-99 = 100 PSI |
| Start Level                 | P1-04 = 80 PSI  | P1-04 = 80 PSI  |

<1> All other multiplexing and alternation parameters are set to default settings.

### Duplex System with Fine Tuning Application Example

The customer would like to solve a pump cycling problem. Currently the second drive runs for 10 to 20 seconds at minimum speed then shuts off, letting the first drive run at maximum. This will then run the second drive again and the cycle will repeat. The customer must also account for system losses when running both pumps by boosting the setpoint by 5 PSI. In the event that the pressure exceeds 125 PSI, the second drive should de-stage if both drives are running. If the pressure exceeds 140 PSI, a high feedback fault should occur and stop the drive.

There are multiple methods to handle the pump cycling problem:

- Lower the lag fixed speed (P9-06)

## 4.8 iQpump Presets and Functions

- Decrease the lag fixed speed delay (P9-07)
- Increase the staging frequency level (P9-09)
- Increase the staging delay time (P9-11)
- Increase the de-staging delay time (P9-15)
- Increase the stabilization time (P9-16)
- Increase both the Add Freq Level and Add Dly Time

**Table 4.12 Related Parameters for Duplex System with Fine Tuning Application Example**

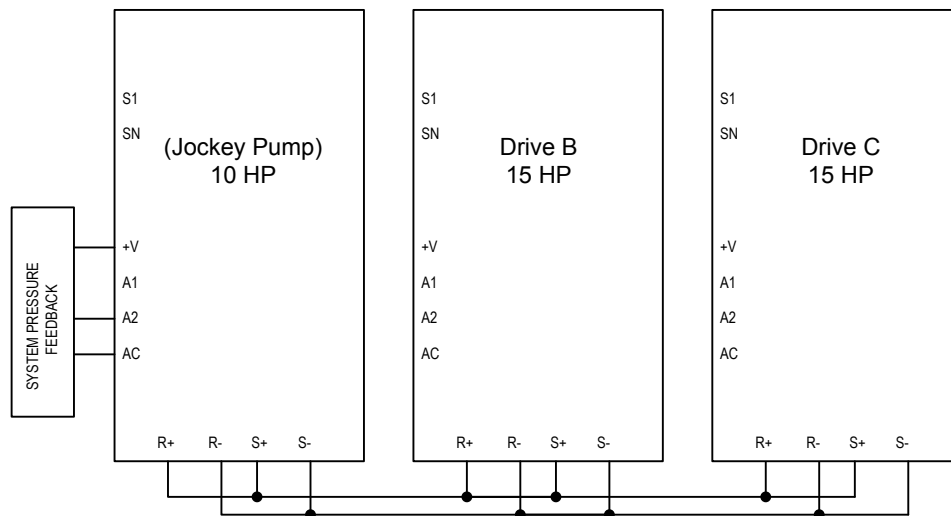
| Description                  | Drive A <1>     | Drive B <1>     |
|------------------------------|-----------------|-----------------|
| Run Source: 1 (Terminals)    | b1-02 = 1       | b1-02 = 1       |
| Node Address                 | H5-01 = 1       | H5-01 = 2       |
| Highest Node Address         | P9-25 = 2       | P9-25 = 2       |
| Pump Mode: 3 (Network)       | P1-01 = 3       | P1-01 = 3       |
| Feedback Source: 0 (Analog)  | P9-02 = 0       | P9-02 = 0       |
| Lag Fixed Speed              | P9-06 = 54.0 Hz | P9-06 = 54.0 Hz |
| Setpoint                     | U5-99 = 100 PSI | U5-99 = 100 PSI |
| Start Level                  | P1-04 = 140 PSI | P1-04 = 140 PSI |
| High Feedback Quick De-Stage | P9-18 = 89.3%   | P9-18 = 89.3%   |
| Setpoint Modifier            | P9-17 = 5.0 PSI | P9-17 = 5.0 PSI |
| Add Drive Frequency Level    | P9-09 = 59.0 Hz | P9-09 = 59.0 Hz |
| Add Drive Delay              | P9-11 = 12.0 s  | P9-11 = 12.0 s  |

<1> All other multiplexing and alternation parameters are set to default settings.

### Duplex System with Jockey Pump Example

A customer requires a pump system with the following requirements:

- One small pump (the Jockey pump) will run the system during off-peak times.
- Two larger pumps will run the system when the demand is higher.
- The Jockey pump should not run when the two larger pumps are running.
- Pump wear is still an issue, but it is expected that the small pump will run longer hours and will always run first after a loss of power.
- The feedback scale is 145 PSI.
- There is only one feedback transducer in the system.



**Figure 4.15 Simplified Wiring Diagram**

**Table 4.13 Related Parameters for Duplex System with Jockey Pump Example**

| Description          | Jockey Pump <1> | Drive B <1> | Drive C <1> |
|----------------------|-----------------|-------------|-------------|
| Node Address         | H5-01 = 1       | H5-01 = 2   | H5-01 = 3   |
| Highest Node Address | P9-25 = 3       | P9-25 = 3   | P9-25 = 3   |

| Description                               | Jockey Pump <1> | Drive B <1>     | Drive C <1>     |
|---|-----------------|-----------------|-----------------|
| Pump Mode: 3 (Network)                    | P1-01 = 3       | P1-01 = 3       | P1-01 = 3       |
| Feedback Source: 0 (Analog), 3 (Network)  | P9-02 = 0       | P9-02 = 3       | P9-02 = 3       |
| Lag Drive Speed: 0 (Always), 2 (Turn Off) | P9-05 = 2       | P9-05 = 0       | P9-05 = 0       |
| Allow Net Run: 0 (Always), 2 (First Only) | P9-20 = 2       | P9-20 = 0       | P9-20 = 0       |
| Run Priority                              | P9-21 = 7       | P9-21 = 8       | P9-21 = 8       |
| Lead Swap @ Sleep                         | P9-24 = 0       | P9-24 = 1200 s  | P9-24 = 1200 s  |
| Setpoint                                  | U5-99 = 100 PSI | U5-99 = 100 PSI | U5-99 = 100 PSI |
| Start Level                               | P1-04 = 80 PSI  | P1-04 = 80 PSI  | P1-04 = 80 PSI  |

<1> All other multiplexing and alternation parameters are set to default settings.

**Triplex System Example**

A customer who currently runs a duplex system would like to retrofit an existing triplex system with the following requirements:

- Three similarly sized pumps would run the system.
- A maximum of two drives should be running at any point; the third drive is a backup.
- Alternation should only happen when pumps are not running (sleeping).
- If one of the analog pressure feedback transducers should fail, read from a working one and notify the customer of the failure by the alarm display.
- Setpoint is 90 PSI, feedback scale is 145 PSI, start level is 75 PSI.

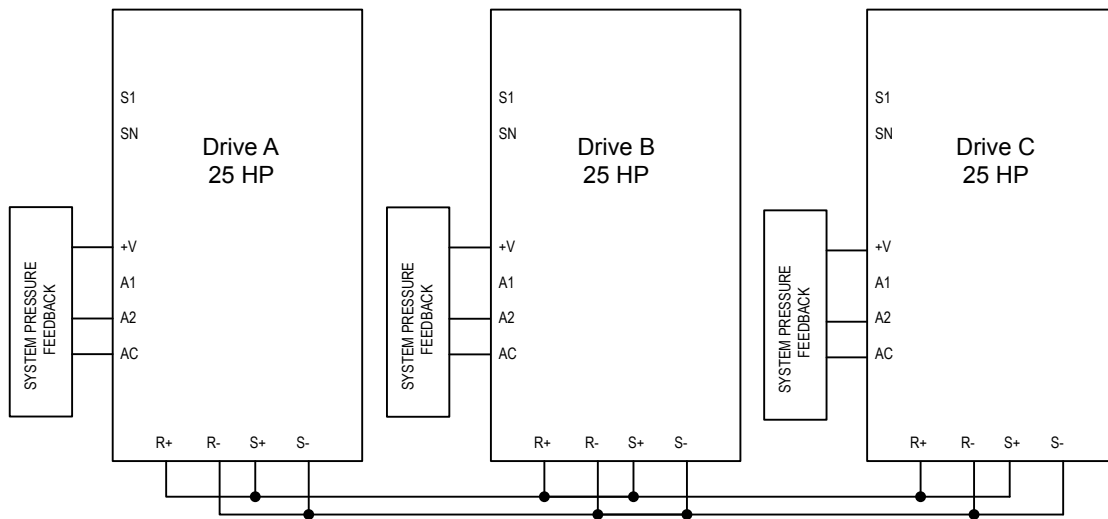


Figure 4.16 Simplified Wiring Diagram

Table 4.14 Related Parameters for Triplex System Example

| Description                                   | Drive A <1>    | Drive B <1>    | Drive C <1>    |
|---|----------------|----------------|----------------|
| Node Address                                  | H5-01 = 1      | H5-01 = 2      | H5-01 = 3      |
| Highest Node Address                          | P9-25 = 3      | P9-25 = 3      | P9-25 = 3      |
| Pump Mode: 3 (Network)                        | P1-01 = 3      | P1-01 = 3      | P1-01 = 3      |
| Feedback Source: 2 (Analog ->Net, with Alarm) | P9-02 = 2      | P9-02 = 2      | P9-02 = 2      |
| Alternation Mode: 3 (FIFO @ Sleep)            | P9-04 = 3      | P9-04 = 3      | P9-04 = 3      |
| Maximum Running Pumps                         | P9-23 = 2      | P9-23 = 2      | P9-23 = 2      |
| Setpoint                                      | U5-99 = 90 PSI | U5-99 = 90 PSI | U5-99 = 90 PSI |
| Start Level                                   | P1-04 = 75 PSI | P1-04 = 75 PSI | P1-04 = 75 PSI |

<1> All other multiplexing and alternation parameters are set to default settings.

## 4.8 iQpump Presets and Functions

### ■ Multiplexing Stop History

Many irrigation-pumping skids consist of a PM pump (Pressure Maintenance) and typically two larger booster pumps to maintain high flow peak demands. In many cases depending on the number of irrigation zones in combination with the type of sprinkler heads used, the flow demand fluctuates and may not require the use of both larger booster pumps at the same time until higher flow rates are required. The drive Controller "Run Stop" history ensures that both booster pumps alternate each run cycle.

**Table 4.15 P9-01, Lead Drive Selection, Detection Settings**

| Setting | Description  |
|---------|--|
| 0       | Next Available<br>Select next available drive on the network as the new lead drive                     |
| 1       | Lowest Runtime (default)<br>Select the iQpump Controller with the lowest runtime as the new lead drive |
| 2       | Stop History<br>Select the iQpump that had been stopped for the longest time.                          |

**Note:** The new lead drive selection also applies to Alternation (P9-03 > 0) and will use the Stop History list when finding the alternate.

### Triplex Irrigation Booster System Example

When pressure is dropping, the PM Pump (if installed) will attempt to return the system pressure to the desired setpoint level. If the PM Pump is not able to return the system to the setpoint pressure, typically due to a greater flow demand, the booster pump #1 will be staged on.

The drive controller will speed up or slow down the pump as needed to maintain the system pressure. When flow decreases and the pump system is no longer required to run, the system will go to sleep waiting for the pressure to drop. On the next run cycle the PM pump will start up again, and instead of running booster pump #1, booster pump #2 is staged on, since booster #1 ran during the last cycle.

This method ensures that during normal operation both booster pumps will operate evenly as lead or lag pumps each run cycle.

A triplex irrigation booster system has one PM Pump (pressure maintenance) and two larger booster pumps of the same horsepower. The customer would like to ensure that the PM Pump is also the lead pump to recharge the system during low flow usage, but during high demands the booster pumps alternate on each run cycle or if required will both run to support very high flow demands.

- Jockey/PM Pump will also be lead to start.
- Jockey/PM Pump will stage booster pump 1 or 2 and stay running for 20 seconds and then shut off.
- Booster pump 1 will run system and if required, call for booster pump 2 or vice versa.
- On sleep mode, the lead drive for starting will swap back to Jockey/PM Pump.
- System setpoint 100 PSI.
- Pressure drop of 10 PSI will start the Jockey pump.
- All drives have individual transducers rated 200 PSI maximum, but if there is a transducer failure, switch to network.

### Triplex Irrigation Booster System Related Parameters

**Table 4.16 Related Parameters**

| Parameter No. | Parameter Name          | PM Pump   | Booster Pump 1 | Booster Pump 2 |
|---------------|-------------------------|-----------|----------------|----------------|
| H5-01         | Drive Node Address      | 1         | 2              | 3              |
| P1-01         | Pump Mode               | 3         | 3              | 3              |
| P1-03         | Feedback Device Scaling | 200 PSI   | 200 PSI        | 200 PSI        |
| P1-04         | Start / Draw Down Level | -10.0 PSI | -10.0 PSI      | -10.0 PSI      |
| P9-01         | Lead Drive Selection    | 2         | 2              | 2              |
| P9-02         | Feedback Source         | 2         | 2              | 2              |
| P9-07         | Lag Fixed Speed Delay   | 20 s      | 5 s            | 5 s            |
| P9-20         | Allow Network Run       | 2         | 0              | 0              |
| P9-21         | Run Priority            | 7         | 8              | 8              |
| P9-24         | Lead Swap at Sleep      | 0 s       | 1 s            | 1 s            |
| P9-25         | Highest Node Address    | 3         | 3              | 3              |
| U5-99         | PID Setpoint Command    | 100 PSI   | 100 PSI        | 100 PSI        |

## 4.9 Auto-Tuning

### ◆ Stationary Auto-Tuning

| Type   | Setting   | Application Conditions and Benefits   | Control Mode |
|--|-----------|---|--------------|
| Stationary Auto-Tuning for Line-to-Line Resistance (V/f and OLV Control) | T1-01 = 2 | For use when: <ul style="list-style-type: none"> <li>The motor cable exceeds 50 m</li> <li>The motor cable length has been modified after Auto-Tuning has been previously performed</li> <li>When motor capacity and drive capacity differ</li> </ul> | V/f Control  |

**Note:** Auto-Tuning cannot be performed on permanent magnet motors (IPM, SPM, etc.).

### ◆ Before Auto-Tuning the Drive

Check the items below before Auto-Tuning the drive.

#### ■ Basic Auto-Tuning Preparations

- Auto-Tuning automatically determines the electrical characteristics of the motor. This is fundamentally different from other types of Auto-Tuning features used in servo systems.
- Auto-Tuning requires the user to input data from the motor nameplate. Make sure the information written on the nameplate is available before Auto-Tuning the drive.
- For best performance, be sure the drive input supply voltage equals or exceeds the motor rated voltage.
  - Note:** Performance can be enhanced by using a motor with a base voltage that is 20 V (40 V for 400 V class models) lower than the input supply voltage. This may be of special importance when operating the motor above 90% of base speed, where high torque precision is required.
- Auto-Tuning is not possible with permanent magnet motors.
- To cancel Auto-Tuning, press the OFF key on the LCD operator.
- [Table 4.17](#) describes digital input and output terminal status during Auto-Tuning.

Table 4.17 Digital Input and Output Operation During Auto-Tuning

| Auto-Tuning Type                                   | Digital Input | Digital Output                                   |
|--|---------------|--|
| Stationary Auto-Tuning for Line-to-Line Resistance | Not available | Maintains the status at the start of Auto-Tuning |

**WARNING! Sudden Movement Hazard.** Do not release the mechanical brake during stationary Auto-Tuning. Inadvertent brake release may cause damage to equipment or injury to personnel. Ensure that the mechanical brake release circuit is not controlled by the drive multi-function digital outputs.

#### ■ Notes on Stationary Auto-Tuning for Terminal Resistance Only

- If the motor cable lead length has been significantly modified after Auto-Tuning has already been performed, perform Stationary Auto-Tuning with the new cables.
- Perform when using motor cables longer than 50 m with V/f Control.

**WARNING! Electrical Shock Hazard.** When executing stationary Auto-Tuning for line-to-line resistance only, the motor does not rotate, however, power is applied. Do not touch the motor until Auto-Tuning is completed. Failure to comply may result in injury from electrical shock.

### ◆ Auto-Tuning Interruption and Fault Codes

If tuning results are abnormal or the STOP key is pressed before completion, Auto-Tuning will be interrupted and a fault code will be displayed on the digital operator.

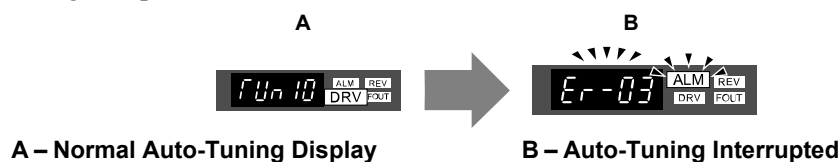


Figure 4.17 Auto-Tuning Interruption Display (Standard Digital LED Operator)

### ◆ Performing Auto-Tuning

#### ■ Auto-Tuning Procedure

Auto-Tuning should generally be performed in the following steps.

1. [Refer to Before Auto-Tuning the Drive on page 101.](#)
2. Determine which type of Auto-Tuning best fits the application requirements following [Figure 4.18.](#)

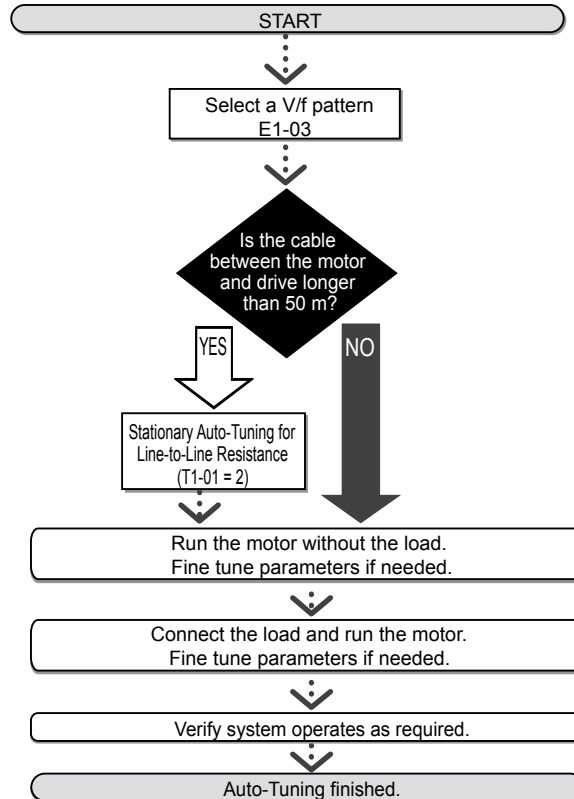


Figure 4.18

3. Enter the type 2 of Auto-Tuning to parameter T1-01.
4. Enter the motor nameplate data.
5. Start the Auto-Tuning process when prompted by the drive.
6. If Auto-Tuning was successfully performed, do a test run without the load and make any necessary parameter adjustments.
7. If the test run was successful, do a test run with the load connected and make parameter adjustments if necessary.

### ◆ Input Data for Auto-Tuning

The T1-□□ parameters are used to set the Auto-Tuning input data.

- Note:**
1. Cycling power to the drive will reset any values set during the Auto-Tuning process to factory defaults.
  2. For motors that are to be operated in the field weakening range, first perform the Auto-Tuning with the base data, i.e. the frequency at which the motor is operating with its rated voltage (base frequency). After Auto-Tuning is complete, change the maximum frequency E1-04 to the desired value.

#### ■ T1-01: Tuning Mode Selection

Sets the type of Auto-Tuning to be used. [Refer to Stationary Auto-Tuning on page 101](#) for details on Stationary Auto-Tuning.

| No.   | Name                       | Setting Range | Default |
|-------|----------------------------|---------------|---------|
| T1-01 | Auto-Tuning Mode Selection | 2 (V/f)       | 2 (V/f) |

#### Setting 2: Stationary Auto-Tuning for Line-to-Line Resistance

### ■ T1-02: Motor Rated Power

Used to set the motor rated power according to the motor nameplate value. For optimal performance, the motor rated power should be between 50 and 100% of the drive rating.

| No.   | Name              | Setting Range | Default                       |
|-------|-------------------|---------------|-------------------------------|
| T1-02 | Motor Rated Power | </>           | Determined by o2-04 and C6-01 |

<1> The setting range differs based on drive software version.

PRG: 1016 and later: 0.03 to 650.00 kW

PRG: 1015 and earlier: 0.00 to 650.00 kW

### ■ T1-04: Motor Rated Current

Used to set the motor rated current according to the motor nameplate value. For optimal performance in OLV, the motor rated current should be between 50 and 100% of the drive rating. Enter the current at the motor base speed.

| No.   | Name                | Setting Range                     | Default                       |
|-------|---------------------|-----------------------------------|-------------------------------|
| T1-04 | Motor Rated Current | 10 to 200% of drive rated current | Determined by o2-04 and C6-01 |

## 4.10 No-Load Operation Test Run

### ◆ No-Load Operation Test Run

This section explains how to operate the drive with the motor uncoupled from the load during a test run.

#### ■ Before Starting the Motor

Check the following items before operation:

- Ensure the area around the motor is safe.
- Ensure external emergency stop circuitry is working properly and other safety precautions have been taken.



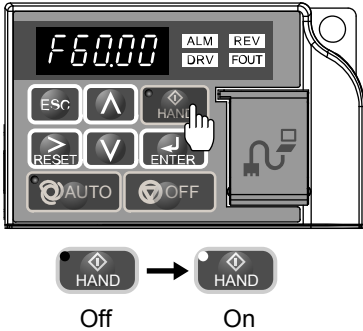
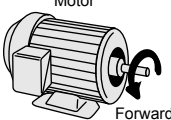


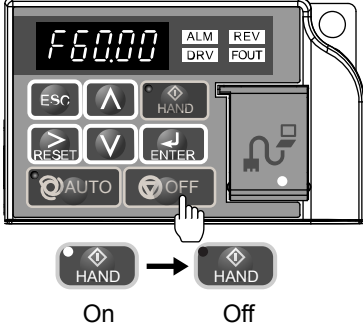
#### ■ During Operation

Check the following items during operation:

- The motor should rotate smoothly (i.e., no abnormal noise or oscillation).
- The motor should accelerate and decelerate smoothly.

#### ■ No-Load Operation Instructions (Standard Digital LED Operator)

The following example illustrates a test run procedure using the digital operator.

| Step |   | Display/Result  |
|------|---|---|
| 1.   | Turn on the power to the drive. The initial display appears.  |    |
| 2.   | Press  to give the drive a Run command from HAND mode. The HAND light will turn on and the motor will rotate at 40 Hz.   |   |
| 3.   | Ensure the motor is rotating in the correct direction and no faults or alarms occur.  |  |
| 4.   | If there is no error in step 3, press  to increase the frequency reference. Increase the frequency in 10 Hz increments verifying smooth operation results at all speeds. For each frequency, monitor the drive output current (U1-03) through the LED operator to confirm the current is well below the motor rated current. Example: 40 Hz → 60 Hz. | –   |
| 5.   | The drive should operate normally. Press  to stop the motor. The HAND light is off and the motor coasts to stop.   |  |



## 4.11 Test Run with Load Connected

### ◆ Test Run with the Load Connected

After performing a no-load test run connect the load and proceed to run the motor and load together.

#### ■ Notes on Connected Machinery

- Clear the area around the motor.
- The motor should come to a complete stop without problems.
- Connect the machinery.
- Fasten all installation screws properly. Check that the motor and connected machinery are held in place.
- Confirm that the Fast-stop circuit or mechanical safety measures operate correctly.
- Be ready to press the OFF button in case of emergency.

#### ■ Checklist Before Operation

- The motor should rotate in the proper direction.
- The motor should accelerate and decelerate smoothly.

#### ■ Operating the Motor under Loaded Conditions

Test run the application similarly to the no-load test procedure when connecting the machinery to the motor.

- Check monitor parameter U1-03 to ensure there is no overcurrent.
- If the application permits running the load in the reverse direction, try changing motor direction and the frequency reference while watching for abnormal motor oscillation or vibration.
- Correct any problems that occurs with hunting, oscillation, or other control-related issues.

## 4.12 Verifying Parameter Settings and Backing Up Changes

Check changes to parameter settings as a result of Auto-Tuning using the Verify function. *Refer to Verifying Parameter Changes: Modified Constants Menu on page 83.*

Save the verified parameter settings. Change the access level or set a password to the drive to prevent accidental modification of parameter settings.

### ◆ Backing Up Parameter Values: o2-03

Performing the following procedure stores all parameters settings to drive memory where they can later be recalled if necessary. Set o2-03 to “1” to save parameter changes. This saves all parameter settings, and then returns o2-03 to 0. The drive can now “recall” the saved parameters by performing a “user-initialization” (A1-03 = 1110).

| No.   | Parameter Name               | Description  | Setting Range | Default Setting |
|-------|------------------------------|--|---------------|-----------------|
| o2-03 | User Parameter Default Value | Allows storing of parameter settings as a User Initialization Selection.<br>0: Saved/Not set<br>1: Set Defaults - Saves current parameter settings as user default settings.<br>2: Clear All - Clears the currently saved user settings. After saving the user parameter set value, the items of 1110 (User Parameter Initialize) are displayed in A1-03 (User Parameter Default Value).   | 0 to 2        | 0               |
| A1-03 | Initialize Parameters        | Selects a method to initialize the parameters.<br>0: No Initialize<br>1110: User Initialize (The user must first program and store desired settings using parameter o2-03)<br>2220: 2-Wire Initialization (parameter initialized prior to shipment)<br>3330: 3-Wire Initialization<br>5550: oPE4 Fault reset<br>6008: Pressure Control Application Preset<br><i>(Refer to Pump Application Presets on page 86)</i><br>6009: Pump Down Level Application Preset<br><i>(Refer to Pump Application Presets on page 86)</i><br>7770: General Purpose Application Preset<br><i>(Refer to Pump Application Presets on page 86)</i><br>7771: Submersible Motor General Purpose Operation<br><i>(Refer to Pump Application Presets on page 86)</i> | 0 to 7771     | 0               |

### ◆ Parameter Access Level: A1-01

Setting the Access Level for “Operation only” (A1-01 = 0) allows the user to access parameters A1-□□ and U□-□□ only. Other parameters are not displayed.



Setting the Access Level for “User Parameters” (A1-01 = 1) allows the user to access parameters that have been previously saved as User Parameters. This is helpful when displaying only the relevant parameters for a specific application.

| No.   | Parameter Name         | Description  | Setting Range | Default |
|-------|------------------------|--|---------------|---------|
| A1-01 | Access Level Selection | Selects which parameters are accessible via the digital operator.<br>0: Operation only (A1-01, -04, and -06 can be set and monitored. U parameters can be monitored)<br>1: User Parameters (Only those recently changed among application parameters A2-01 to -16 and A2-17 to -32 can be set and monitored)<br>2: Advanced Access Level (All parameters can be set and monitored)<br>3: Lock Parameters (Parameters that are normally visible in the advanced access level (A1-01 = 2) are still visible, but the only parameters that can be changed are A1-01 and A1-04.) | 0 to 3        | 2       |

### ◆ Password Settings: A1-04, A1-05

The user can set a password to the drive to restrict access. The password is selected via parameter A1-05. The selected password must be entered in parameter A1-04 to unlock parameter access (i.e., parameter setting A1-04 must match the value programmed into A1-05). The following parameters cannot be viewed or edited until the value programmed into A1-04 correctly matches the value as programmed in parameter A1-05: A1-01, A1-02, A1-03, A1-06 and A2-01 through A2-33.

**Note:**

Parameter A1-05 is hidden from view. To display A1-05, access parameter A1-04 and simultaneously depress the  key and the  key.

### ◆ Copy Function (Optional)

#### ■ USB/Copy Unit (JVOP-181)

The copy unit is an external option connected to the drive to copy parameter settings to another drive. It includes a USB adapter to connect the drive to a PC.

#### ■ HOA RTC Operator (JVOP-183)

Digital operator with Real Time Clock function, LCD keypad display and copy function.

#### ■ DriveWizard iQpump

DriveWizard iQpump is a PC software tool for parameter management, monitoring, and diagnosis. DriveWizard iQpump can load, store, and copy drive parameter settings. For details, refer to Help in the DriveWizard iQpump software.

### 4.13 Test Run Checklist

Review the checklist before performing a test run. Check each item that applies.

**WARNING!** Ensure start/stop and safety circuits are wired properly and in the correct state before energizing the drive. Failure to comply could result in death or serious injury from moving equipment. When programmed for 3-Wire control, a momentary closure on terminal S1 may cause the drive to start.

| <input checked="" type="checkbox"/> | No. | Checklist   | Page |
|-------------------------------------|-----|---|------|
| <input type="checkbox"/>            | 1   | Thoroughly read the manual before performing a test run.  | –    |
| <input type="checkbox"/>            | 2   | Turn the power on.  | 68   |
| <input type="checkbox"/>            | 3   | Set the voltage for the power supply to E1-01.  | 155  |
| <input type="checkbox"/>            | 4   | Select the best V/f pattern according to the application and motor characteristics.<br>Example: If using a motor with a rated frequency of 60.0 Hz, set E1-03 to “1”.                                   | –    |
| <input type="checkbox"/>            | 5   | The <b>DRV</b> should illuminate after giving a run command using the AUTO key.   | –    |
| <input type="checkbox"/>            | 6   | If the motor rotates in the opposite direction during the test run, switch two of the drive output terminals (U/T1, V/T2, W/T3).  | 68   |
| <input type="checkbox"/>            | 7   | If the control circuit terminals should supply the frequency reference, select the correct voltage input signal level (0 to 10 V) or the correct current input signal level (4 to 20 mA or 0 to 20 mA). | 68   |
| <input type="checkbox"/>            | 8   | Set the proper voltage to terminal A1. (0 to 10 V).   | 115  |
| <input type="checkbox"/>            | 9   | Set the proper current to terminal A2. (4 to 20 mA or 0 to 20 mA).  | 115  |
| <input type="checkbox"/>            | 10  | When current input is used, set H3-09 to “2” (4 to 20 mA) or “3” (0 to 20 mA) and set H3-10 to “0”.   | –    |
| <input type="checkbox"/>            | 11  | When current input is used, switch the drive built-in DIP switch S1 from the V-side (OFF) to I-side (ON).   | –    |

## Parameter Details

---

|      |                                   |     |
|------|-----------------------------------|-----|
| 5.1  | A: INITIALIZATION.....            | 110 |
| 5.2  | B: APPLICATION.....               | 115 |
| 5.3  | C: TUNING.....                    | 140 |
| 5.4  | D: REFERENCE SETTINGS.....        | 147 |
| 5.5  | E: MOTOR PARAMETERS.....          | 155 |
| 5.6  | F: OPTION SETTINGS.....           | 161 |
| 5.7  | H: TERMINAL FUNCTIONS.....        | 163 |
| 5.8  | L: PROTECTION FUNCTIONS.....      | 189 |
| 5.9  | N: SPECIAL ADJUSTMENTS.....       | 213 |
| 5.10 | O: OPERATOR RELATED SETTINGS..... | 215 |
| 5.11 | P: PUMP.....                      | 223 |
| 5.12 | Q: PID CONTROLLER.....            | 245 |
| 5.13 | U: MONITOR PARAMETERS.....        | 247 |

## 5.1 A: Initialization

The initialization group contains parameters associated with initial setup of the drive. Parameters involving the display language, access levels, initialization, and password are located in this group.

### ◆ A1: Initialization

#### ■ A1-00: Language Selection

Selects the display language for the digital operator.

**Note:** This parameter is not reset when the drive is initialized using parameter A1-03.

| No.   | Parameter Name     | Setting Range | Default |
|-------|--------------------|---------------|---------|
| A1-00 | Language Selection | 0 to 7        | 0       |

**Setting 0: English**

**Setting 1: Japanese**

**Setting 2: German**

**Setting 3: French**

**Setting 4: Italian**

**Setting 5: Spanish**

**Setting 6: Portuguese**

**Setting 7: Chinese**

#### ■ A1-01: Access Level Selection

Allows or restricts access to drive parameters.

| No.   | Parameter Name         | Setting Range | Default |
|-------|------------------------|---------------|---------|
| A1-01 | Access Level Selection | 0 to 3        | 2       |

##### Setting 0: Operation only

Access to only parameters A1-01, A1-04, and all U monitor parameters.

##### Setting 1: User Parameters

Access to only a specific list of parameters set to A2-01 through A2-32. These User Parameters can be accessed using the Setup Mode of the digital operator.

##### Setting 2: Advanced Access Level (A) and Setup Access Level (S)

All parameters can be viewed and edited.

##### Setting 3: Lock Parameters

Parameters that are normally visible in the advanced access level (A1-01 = 2) are still visible, but the only parameters that can be changed are A1-01 and A1-04.

The Auto Tuning and Pump Quick Setup menus will not be displayed.

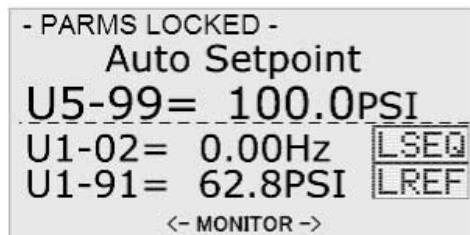


Figure 5.1 Help Message Example (Optional HOA Keypad, JVOP-183, Home Screen)

#### Notes on Parameter Access

- If the drive parameters are password protected by A1-04 and A1-05, parameters A1-00 through A1-03, A1-06, and all A2 parameters cannot be modified.

- If a digital input terminal programmed for “Program lockout” (H1-□□ = 1B) is enabled, parameter values cannot be modified, even if A1-01 is set to 1 or 2.
- If parameters are changed via serial communication, it will not be possible to edit or change parameter settings with the digital operator until an Enter command is issued to the drive from the serial communication.

**■ A1-03: Initialize Parameters**

Resets parameters to default values or performs an Application Preset for fan or pump applications. After initialization, the setting for A1-03 automatically returns to 0.

| No.   | Parameter Name        | Setting Range                                     | Default |
|-------|-----------------------|---|---------|
| A1-03 | Initialize Parameters | 0, 1110, 2220, 3330, 5550, 6008, 6009, 7770, 7771 | 0       |

**Setting 1110: User Initialize**

Resets parameters to the values selected by the user as User Settings. User Settings are stored when parameter o2-03 is set to “1: Set defaults”.

**Note:** User Initialization resets all parameters to a user-defined set of default values previously saved to the drive. Set parameter o2-03 to 2 to clear the user-defined default values.

**Setting 2220: 2-Wire Initialization**

Resets parameters to default settings with digital inputs S1 and S2 configured as Forward run and Reverse run, respectively.

**Setting 3330: 3-Wire Initialization**

Resets parameters to default settings with digital inputs S1, S2, and S5 configured as Run, Stop, and Forward/Reverse respectively.

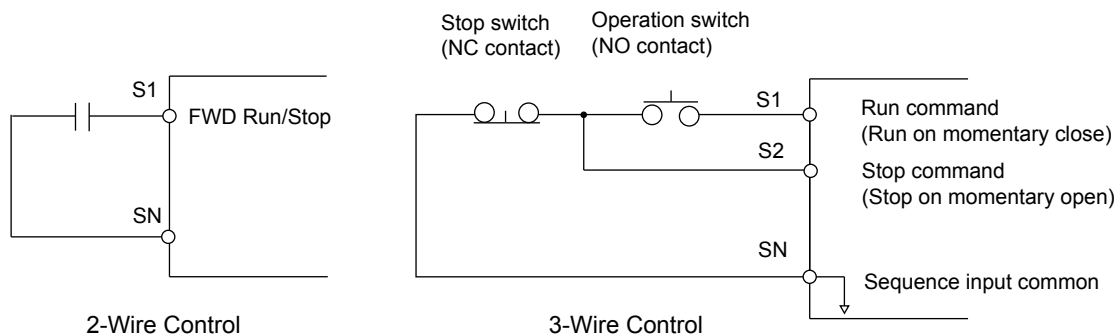


Figure 5.2 2 & 3-Wire Control Wiring Examples

**Notes on Parameter Initialization**

The parameters shown in [Table 5.1](#) will not be reset when the drive is initialized by setting A1-03 = 2220 or 3330.

Table 5.1 Parameters Not Changed by Drive Initialization

| No.   | Parameter Name                |
|-------|-------------------------------|
| A1-00 | Language Selection            |
| E1-03 | V/f Pattern Selection         |
| F6-08 | Communication Parameter Reset |
| L8-35 | Installation Selection        |
| o2-04 | Drive/kVA Selection           |

**Setting 5550: Terminal/Control Initialize**

An oPE04 error appears on the digital operator when a terminal block with settings saved to its built-in memory is installed in a drive that has edited parameters. Set A1-03 to 5550 to use the parameter settings saved to the terminal block memory.

Application Presets are available to facilitate drive setup for commonly used applications. Selecting one of these Application Presets automatically assigns functions to the input and output terminals and sets a predefined group of parameters to values appropriate for the selected application.

## 5.1 A: Initialization

In addition, the parameters most likely to be changed are assigned to the group of User Parameters, A2-01 through A2-16. User Parameters are part of the Setup Group, which provides quicker access by eliminating the need to scroll through multiple menus.

*Refer to Pump Application Presets on page 86* for detailed information on Application Presets.

### Setting 6008: Pressure Control

Application Preset for Pressure Control applications. *Refer to Pump Application Presets on page 86* for a list of parameters and default values for this Application Preset.

### Setting 6009: Pump Down Level

Application Preset for Pump Down Level applications. *Refer to Pump Application Presets on page 86* for a list of parameters and default values for this Application Preset.

### Setting 7770: General Purpose

General Purpose Application Preset. *Refer to Pump Application Presets on page 86* for a list of parameters and default values for this Application Preset.

### Setting 7771: Submersible Motor General Purpose Operation

General Purpose Application Preset. *Refer to Pump Application Presets on page 86* for a list of parameters and default values for this Application Preset.

## ■ A1-04, A1-05: Password and Password Setting

A1-04 is for entering the password when the drive is locked. A1-05 is a hidden parameter used to set the password.

| No.   | Parameter Name   | Setting Range | Default |
|-------|------------------|---------------|---------|
| A1-04 | Password         | 0 to 9999     | 0       |
| A1-05 | Password Setting |               |         |

### How to use the Password

The user can set a password for the drive to restrict access. The password is set to A1-05 and must be entered to A1-04 to unlock parameter access. Until the correct password is entered, the following parameters cannot be viewed or edited: A1-01, A1-03, A1-06, and A2-01 through A2-33.

The instructions below demonstrate how to set a new password. Here, the password set is “1234”. An explanation follows on how to enter the password to unlock the parameters.

**Table 5.2 Setting the Password for Parameter Lock (Standard Digital LED Operator)**

| Step   | Display/Result   |
|--|------------------|
| 1. Turn on the power to the drive. The initial display appears.  |                  |
| 2. Scroll to the Parameter Setup display and press   |                  |
| 3. Scroll to the right by pressing   |                  |
| 4. Select the flashing digits by pressing  |                  |
| 5. Select A1-04 by pressing  |                  |
| 6. Press the  key while holding down  at the same time. A1-05 will appear.<br><b>Note:</b> A1-05 is normally hidden, but can be displayed by following the directions listed here. | <br>“05” flashes |
| 7. Press the  key.   |                  |
| 8. Use , , and  to enter the password.   |                  |
| 9. Press  to save what was entered.  |                  |
| 10. The display automatically returns to the display shown in step 5.  |                  |



Table 5.3 Check to see if A1-01 is locked (continuing from step 10 above)










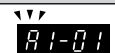



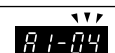













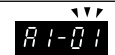
| Step |  |   | Display/Result  |
|------|--|---|---|
| 1.   | Press  to display A1-01.  | → |  |
| 2.   | Press  to display the value set to A1-01.   | → |  |
| 3.   | Press  and  , making sure that the setting values cannot be changed. |   |   |
| 4.   | Press  to return to the first display.  | → |  |

Table 5.4 Enter the Password to Unlock Parameters (continuing from step 4 above)

| Step |   |   | Display/Result  |
|------|---|---|---|
| 1.   | Press  to enter the parameter setup display.   | → |    |
| 2.   | Press  to select the flashing digits as shown.   | → |    |
| 3.   | Press  to scroll to A1-04.   | → |    |
| 4.   | Enter the password "1234".  | → |    |
| 5.   | Press  to save the new password.   | → |    |
| 6.   | Drive returns to the parameter display.   | → |    |
| 7.   | Press  and scroll to A1-01.  | → |    |
| 8.   | Press  to display the value set to A1-01. If the first "0" blinks, parameter settings are unlocked.   | → |   |
| 9.   | Use  and  to change the value if desired. This is not typical.                            |   |   |
| 10.  | Press  to save the setting, or  to return to the previous display without saving changes. | → |  |
| 11.  | The display automatically returns to the parameter display.   | → |  |

**Note:** Parameter settings can be edited after entering the correct password. Performing a 2-Wire or 3-Wire initialization resets the password to "0000". Reenter the password to parameter A1-05 after drive initialization.

## ◆ A2: User Parameters

### ■ A2-01 to A2-32: User Parameters

The user can select 32 parameters and assign them to A2-01 through A2-32. This saves time later scrolling through the parameter menu. The list of User Parameters can also track the most recently edited settings and save those parameters to this list.

| No.            | Parameter Name          | Setting Range  | Default            |
|----------------|-------------------------|----------------|--------------------|
| A2-01 to A2-32 | User Parameters 1 to 32 | b1-01 to S6-02 | Depending on A1-03 |

#### Saving User Parameters

To save specific parameters to A2-01 to A2-32, first set the access level to allow access to all parameters (A1-01 = 2). Next assign the parameter number to the User Parameters list by entering it into one of the A2-□□ parameters. By then setting A1-01 to "1", the access level can be restricted so that users can only set and reference the specific parameters saved as User Parameters.

### ■ A2-33: User Parameter Automatic Selection

A2-33 determines whether or not parameters that have been edited are saved to the User Parameters (A2-17 to A2-32) for quick, easy access.

## 5.1 A: Initialization

---

| No.   | Parameter Name                     | Setting Range | Default |
|-------|------------------------------------|---------------|---------|
| A2-33 | User Parameter Automatic Selection | 0 or 1        | 0       |

**Setting 0: Do not save list of recently viewed parameters.**

To manually select the parameters listed in the User Parameter group, set A2-33 to “0”.

**Setting 1: Save history of recently viewed parameters.**

By setting A2-33 to 1, all parameters that were recently edited will be automatically saved to A2-17 through A2-32. A total of 16 parameters are saved in order with the most recently edited parameter set to A2-17. User parameters can be accessed using the Setup mode of the digital operator.

## 5.2 b: Application

Application parameters configure the source of the frequency reference, the Run command, DC Injection Braking, Speed Search, various timer functions, PID control, the Dwell function, Energy Savings and a variety of other application-related settings.

### ◆ b1: Mode of Operation

#### ■ b1-01: Frequency Reference Selection 1

Selects the frequency reference source 1 for the AUTO mode.

**Note:** If a Run command is input to the drive but the frequency reference entered is 0 or below the minimum frequency, the RUN indicator LED on the digital operator will light and the STOP indicator will flash.

| No.   | Parameter Name                  | Setting Range | Default |
|-------|---------------------------------|---------------|---------|
| b1-01 | Frequency Reference Selection 1 | 0 to 4        | 0       |

In order to run the drive and motor, the drive must receive a Run command and an Auto Setpoint command. Parameter b1-01 specifies the origin of the Auto setpoint when in AUTO Mode. Switch to AUTO mode by pressing the AUTO button on the HOA keypad while the drive is stopped.

**Note:** If a Run command is input to the drive without a corresponding Auto setpoint, the Run indicator on the HOA keypad will turn on and the STOP indicator on the keypad will blink.

If the drive should follow the “HAND Reference” set by the HOA keypad, use HAND Mode by pressing the HAND key and set P5-01 to “1: Hand Reference (P5-02).” The HAND reference can then be entered into the U1-01 monitor parameter in the “-DRIVE-” Menu.

The drive offers the ability to provide four types of “Auto Setpoint” reference sources. These Auto Setpoint reference sources are determined by the setting of b1-01 and the drive set to AUTO Mode by pressing the AUTO key on the keypad.

Prior to programming, it is recommended to select the system units (P1-02) and the feedback device, Scaling (P1- 03) first. P1-03 will automatically scale the drive setpoint.

Example: P1-02 = 1: PSI

P1-03 = 200, feedback range = 200 PSI.

If the drive should follow an “Auto Set-Point” set by the HOA keypad: Set b1-01 to “0: Operator” (factory default). The Auto setpoint can then be entered into the U5-99 monitor parameter in the “-DRIVE-” menu.

#### Setting 0: Operator (HOA keypad)

Using this setting, the frequency reference can be input by:

- switching between the multi-speed references in the d1-□□ parameters.
- entering the frequency reference on the operator keypad.

This selection will also switch PID setpoint to Q1-01.

#### Setting 1: Terminals (Analog Input Terminals)

Using this setting, an analog frequency reference can be entered from:

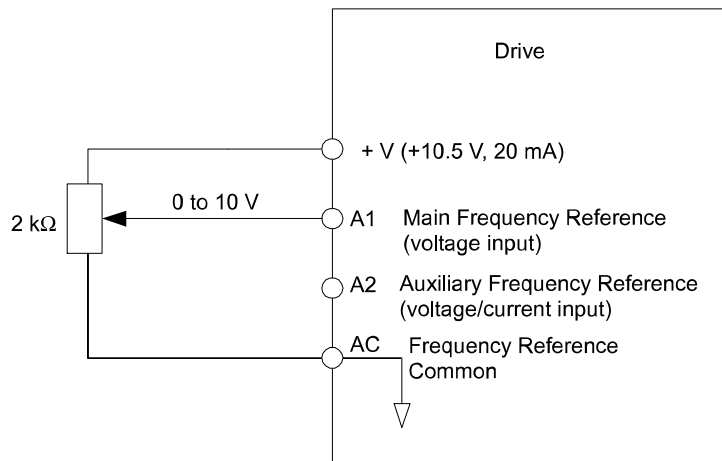
- Terminal A1 using a 0 to 10 Vdc signal.
- Terminal A2 using either a 0 to 10 Vdc or a 0/4 to 20 mA signal.

**Note:** Terminal A2 supports voltage and current input. The input signal type must be set up by setting DIP switch S1 and adjusting parameter H3-09.

#### Entering only the main frequency reference:

Using Control Circuit Terminal A1 (0 to 10 Vdc voltage input):

Use a circuit such as the one shown in [Figure 5.3](#) or an external 0 to 10 Vdc voltage source like a PLC analog output and set the input level selection for A1 in parameter H3-02 as desired.



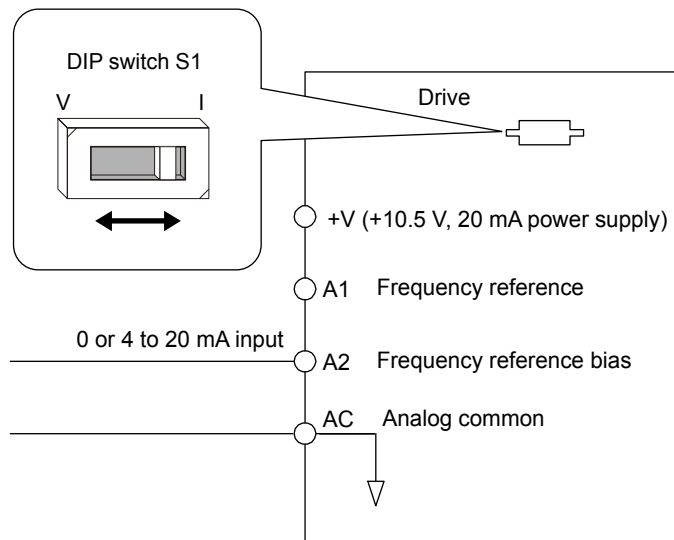
**Figure 5.3 Setting the Frequency Reference by Voltage Input**

- Using Control Circuit Terminal A2 (0 to 10 Vdc voltage input)

Use the same connection as explained for terminal A1 for terminal A2. Make sure that switch S1 is set to “V” and set the appropriate signal level for terminal A2 by entering 0 or 1 into parameter H3-09. The terminal A2 function must be set to frequency bias by entering 0 into parameter H3-10.

- Using Control Circuit Terminal A2 (0/4 to 20 mA current input)

Connect input A2 to an external current source such as the one shown in [Figure 5.4](#). Make sure that switch S1 is set to “I” and set the appropriate signal level for terminal A2 by entering 2 (4 to 20 mA) or 3 (0 to 20 mA) into parameter H3-09. The terminal A2 function must be set to frequency bias by entering 0 into parameter H3-10.



**Figure 5.4 Setting the Frequency Reference by Current Input**

### Switching between Main/Auxiliary Frequency References

The frequency reference input can be switched between terminal A1 (main) and terminal A2 (auxiliary). When using this function:

- Make sure that b1-01 is set to “1” (Frequency reference from analog input).
- Set the terminal A2 function to auxiliary frequency (H3-10 = 2).
- Set one digital input to multi-speed 1 (H1-□□ = 3, default for S5).

The frequency reference value is read from

- Terminal A1 when the digital input set for multi-speed 1 is open.
- Terminal A2 when the digital input set for multi-speed 1 is closed.

[Figure 5.4](#) shows a wiring example for main/auxiliary reference switching using digital input S5.

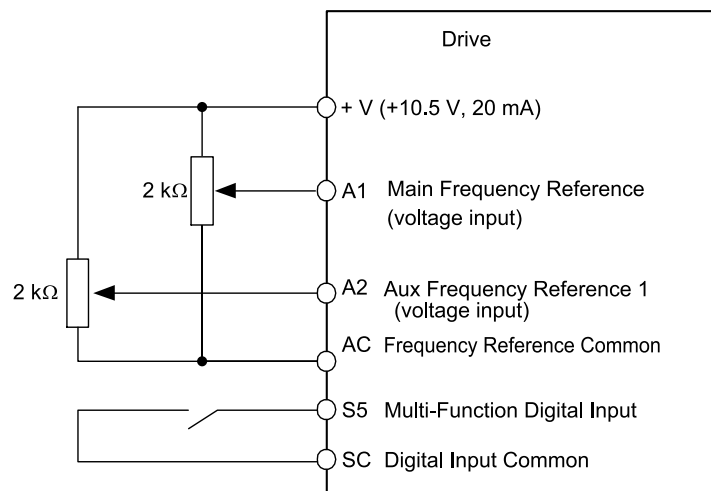


Figure 5.5 Switching between Analog Reference 1 and 2

### Setting 2: MEMOBUS/Modbus Communications

This setting requires entering the frequency reference via the RS-485/422 serial communications port (control terminals R+, R-, S+, S-).

To setup the drive to receive the “Auto Setpoint” from serial communication, set b1-01 to “2: Serial Com,” and connect the RS-422/RS-485 serial communications cable to terminals R+, R-, S+, and S- on the control I/O terminal block. Refer to [117](#) to see the connection diagram using a PC to provide the auto setpoint reference to the drive.

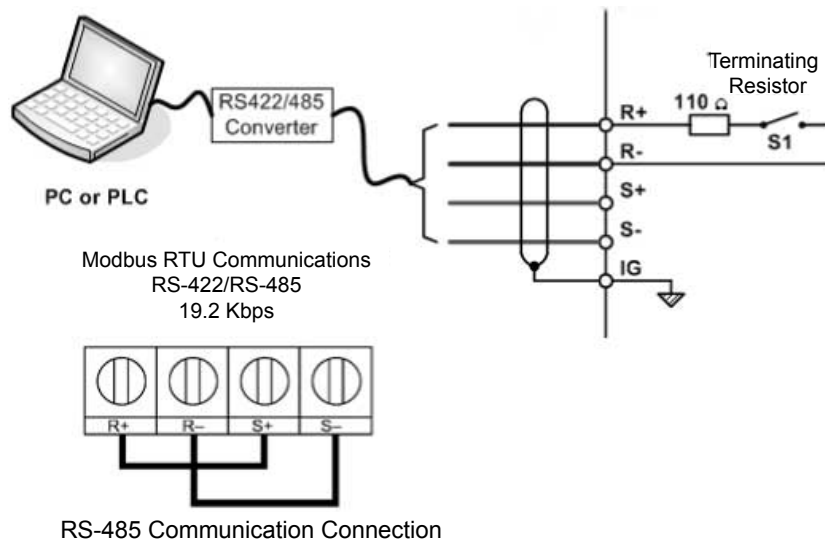


Figure 5.6 PC or PLC Connection Diagram

### Setting 3: Option card

This setting requires entering the frequency reference via an option board plugged into connector CN5 on the drive control board. Consult the option board manual for instructions on integrating the drive with the communication system.

**Note:** If the frequency reference source is set for Option PCB (b1-01 = 3), but an option board is not installed, an oPE05 Operator Programming Error will be displayed on the digital operator and the drive will not run.

To setup the drive to receive the “Auto Setpoint” for a network communication option card, set b1-01 to “3: Option PCB”, and plug a supported communication option card into the drive control PCB. Consult the manual supplied with the option for instructions on integrating the drive into the network system.

### Setting 4: Pulse Train Input

This setting requires a pulse train signal to terminal RP to provide the frequency reference. Follow the directions below to verify that the pulse signal is working properly.

## 5.2 b: Application

| Pulse Train Input Specifications |               |
|----------------------------------|---------------|
| Response Frequency               | 0.5 to 32 kHz |
| Duty Cycle                       | 30 to 70%     |
| High Level Voltage               | 3.5 to 13.2 V |
| Low Level Voltage                | 0.0 to 0.8 V  |
| Input Impedance                  | 3 k $\Omega$  |

### Verifying the Pulse Train is Working Properly

- Set b1-01 to 4 and set H6-01 to 0.
- Set the H6-02 to the pulse train frequency value that equals 100% of the frequency reference.
- Enter a pulse train signal to terminal RP and check for the correct frequency reference on the display.

### ■ b1-02: Run Command Selection 1

Determines the Run command source 1 in AUTO Mode.

The drive comes factory programmed for Start and Stop from the keypad, but the user can program the drive to receive a Run command from four different inputs: digital operator, terminals, serial communications, or an option PCB.

**WARNING!** *Sudden Movement Hazard. Clear personnel, secure equipment, and check sequence and safety circuitry before starting the drive. Failure to comply could result in death or serious injury from moving equipment.*

To set the drive to receive the Run command from the HOA keypad, set b1-02 to “0: Operator,” and the HAND key will be used to provide the Run command to the drive.

To set the drive to receive the Run command from the external terminals, set b1-02 to “1: Terminals” and initiate an external Run command by a contact closure between terminals S1 and SN.

**Note:** Using the external terminals requires setting the drive to AUTO Mode by pressing the AUTO key.

| No.   | Parameter Name          | Setting Range | Default |
|-------|-------------------------|---------------|---------|
| b1-02 | Run Command Selection 1 | 0 to 3        | 0       |

### Setting 0: Operator (HOA keypad)

This setting requires entering the Run command via the HOA keypad AUTO key and also illuminates the HAND indicator on the digital operator.

### Setting 1: Control Circuit Terminal

This setting requires entering the Run command via the digital input terminals using one of following sequences:

- 2-Wire sequence 1:

Two inputs (FWD/Stop-REV/Stop). Set A1-03 to 2220 to initialize the drive and preset terminals S1 and S2 to these functions. This is the default setting of the drive.

- 2-Wire sequence 2:

Two inputs (Start/Stop-FWD/REV).

- 3-Wire sequence:

Three inputs (Start-Stop-FWD/REV). Set A1-03 to 3330 to initialize the drive and preset terminals S1, S2, and S5 to these functions.

### Setting 2: MEMOBUS/Modbus Communications

This setting requires entering the Run command via serial communications by connecting the RS-485/422 serial communication cable to control terminals R+, R-, S+, and S- on the removable terminal block.

### Setting 3: Option Card

This setting requires entering the Run command via the communication option board by plugging a communication option board into the CN5 port on the control PCB. Refer to the option board manual for instructions on integrating the drive into the communication system.

**Note:** If b1-02 is set to 3, but an option board is not installed in CN5, an oPE05 operator programming error will be displayed on the digital operator and the drive will not run.

### ■ b1-03: Stopping Method Selection

Selects how the drive stops the motor when the Run command is removed or when a Stop command is entered.

**Note:** Parameter b1-11, Run Delay at Stop (Back Spin Timer), is effective for all stopping methods (b1-03 = 0 to 3), not only Coast to Stop w/ Timer (b1-03 =3).

| No.   | Parameter Name            | Setting Range | Default |
|-------|---------------------------|---------------|---------|
| b1-03 | Stopping Method Selection | 0 to 3        | 1       |

### Setting 0: Ramp to Stop

When the Run command is removed, the drive will decelerate the motor to stop. The deceleration rate is determined by the active deceleration time. The default deceleration time is set to parameter C1-02.

When the output frequency falls below the level set in parameter b2-01, the drive will start DC injection, Zero Speed Control, or Short Circuit Braking.

### Setting 1: Coast to Stop

When the Run command is removed, the drive will shut off its output and the motor will coast (uncontrolled deceleration) to stop. The stopping time is determined by the inertia and the friction in the driven system.

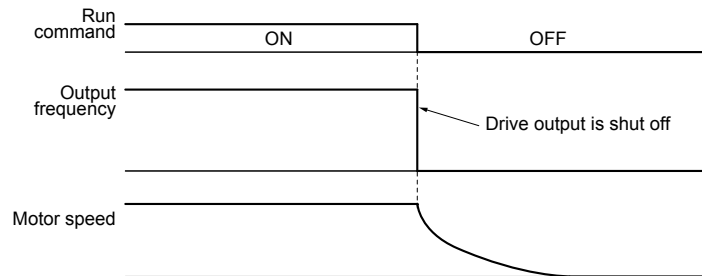


Figure 5.7 Coast to Stop

**Note:** After a stop is initiated, any subsequent Run command entered will be ignored until the minimum baseblock time (L2-03) has expired. Do not enter Run command until it has come to a complete stop. Use DC Injection at Start or Speed Search to restart the motor before it has completely stopped.

### Setting 2: DC Injection Braking to Stop

When the Run command is removed, the drive will enter baseblock (turn off its output) for the minimum baseblock time (L2-03). When the minimum baseblock time has expired, the drive will inject the amount DC Injection Braking is set in parameter b2-02 into the motor windings to brake the motor. The stopping time in DC Injection Braking to Stop is significantly faster compared to Coast to Stop.

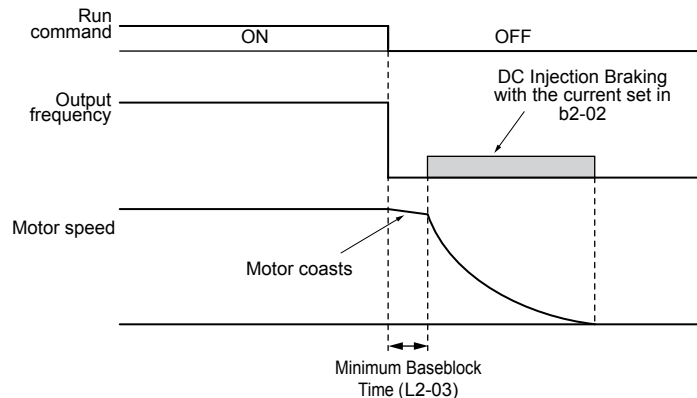
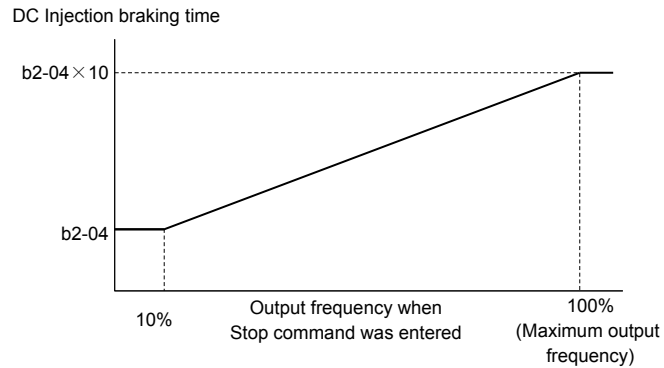


Figure 5.8 DC Injection Braking to Stop

DC Injection Braking time is determined by the value set to b2-04 and the output frequency at the time the Run command is removed. It can be calculated by:

$$\text{DC Injection brake time} = \frac{(b2-04) \times 10 \times \text{Output frequency}}{\text{Max. output frequency (E1-04)}}$$

## 5.2 b: Application

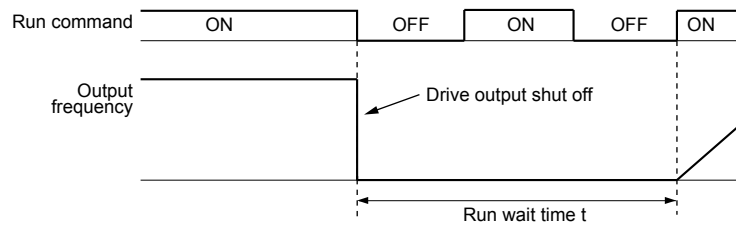


**Figure 5.9 DC Injection Braking Time Depending on Output Frequency**

**Note:** If an overcurrent (oC) fault occurs during DC Injection Braking to Stop, lengthen the minimum baseblock time (L2-03) until the fault no longer occurs.

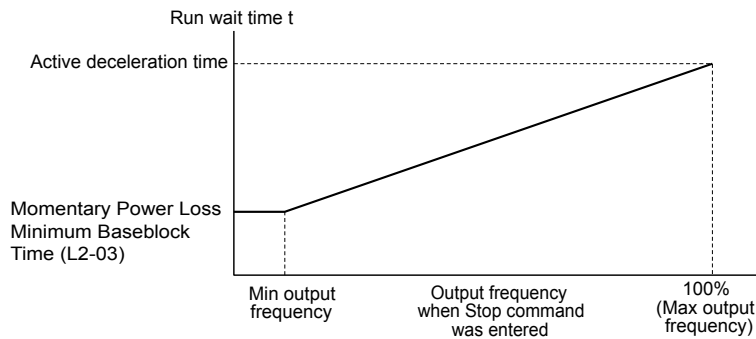
### Setting 3: Coast to Stop with Timer (Used for Back Spin Control on Vertical Turbine Pumps)

When the Run command is removed, the drive coasts to a stop. If parameter b1-11 = 0, the coast-timer (Run Delay at Stop) becomes a value determined by a combination of output frequency and C1-02. However, if b1-11 > 0, the Run Delay at Stop timer is set to b1-11. If the Run command is reissued during the Run Delay at Stop timer time, the drive WILL restart when the timer expires without the need to re-cycle the Run command. The Run Delay at Stop timer will operate for both AUTO Mode and HAND Mode. The Run Delay at Stop timer will still operate when the drive goes to sleep and then wakes up. During the Run Delay at Stop timer execution, the HOA keypad will display a Start Delay message.



**Figure 5.10 Coast to Stop with Timer**

The wait time  $t$  is determined by the output frequency when the Run command is removed and by the active deceleration time.



**Figure 5.11 Run Wait Time Depending on Output Frequency**

### ■ b1-04: Reverse Operation Selection

For some applications, reverse motor rotation is not appropriate and may even cause problems (e.g., air handling units, pumps, etc.). Setting parameter b1-04 to 1 instructs the drive to ignore any Reverse run commands.

| No.   | Parameter Name              | Setting Range | Default |
|-------|-----------------------------|---------------|---------|
| b1-04 | Reverse Operation Selection | 0 or 1        | 0       |

### Setting 0: Reverse Operation Enabled

Possible to operate the motor in both forward and reverse directions.



**Setting 1: Reverse Operation Disabled**

Drive disregards a Reverse run command or a negative frequency reference.

**■ b1-07: Run Command Retention when Source is Changed**

Determines whether the run command is retained when the Sequence Selection is changed.

When this parameter is set to 0 (Require cycle), the drive stops when the Auto Run Command source is switched. If the Run command is already applied from the new source, it will require a cycle for the drive to start running again.

When this parameter is set to 1 (Retain Run Cmd), the drive continues running when the Auto Run Command source is switched and the Run command is already applied from the new source. The Auto Run command is automatically applied when the new source is the operator.

| No.   | Parameter Name                               | Setting Range | Default |
|-------|--|---------------|---------|
| b1-07 | Run Command Retention when Source is Changed | 0 or 1        | 0       |

**Setting 0: Require cycle**

When this parameter is set to 0 (Require cycle), the drive stops when the Auto Run Command source is switched. If the Run command is already applied from the new source, it will require a cycle for the drive to start running again.

**Setting 1: Retain Run command**

When this parameter is set to 1 (Retain Run Cmd), the drive continues running when the Auto Run Command source is switched and the Run command is already applied from the new source. The Auto Run command is automatically applied when the new source is the operator.

**WARNING!** The drive may start unexpectedly if switching control sources when b1-07 = 1. Clear all personnel away from rotating machinery and electrical connections prior to switching control sources. Failure to comply may cause death or serious injury.

**■ b1-08: Run Command Selection while in Programming Mode**

As a safety precaution, the drive will not normally respond to a Run input when the digital operator is being used to adjust parameters in the Programming Mode (Verify Menu, Setup Mode, Parameter Settings Mode, and Auto-Tuning). If required by the application b1-08 can be used to change this functionality.

| No.   | Parameter Name                                  | Setting Range | Default |
|-------|---|---------------|---------|
| b1-08 | Run Command Selection while in Programming Mode | 0 to 2        | 0       |

**Setting 0: Disabled**

A Run command is not accepted while the digital operator is in Programming Mode.

**Setting 1: Enabled**

A Run command is accepted in any digital operator mode.

**Setting 2: Prohibit Programming During Run**

It is not possible to enter the Programming Mode as long as the drive output is active.

**■ b1-11: Run Delay at Stop (Back Spin Timer)**

If a time is set to b1-11, the drive will delay executing a Run command until the set time has expired. During Run Delay at Stop execution, the HOA keypad will display “WrUn”. Both Alarm and Run indicators will blink while the drive waits to execute the Run command.

When this parameter is set to zero and b1-03 = 3 (Coast to Stop w/ Timer), a combination of C1-02 and output frequency will determine the length of time. Otherwise, no run delay will be applied.

This parameter setting is effective for all Stopping Methods, not only Coast to Stop w/ Timer (b1-03 = 3).

| No.   | Parameter Name                      | Setting Range   | Default |
|-------|-------------------------------------|-----------------|---------|
| b1-11 | Run Delay at Stop (Back Spin Timer) | 0.0 to 6000.0 s | 0.0 s   |

**■ b1-12: Run Delay Memory Selection**

Selects whether the Run Delay Timer is saved to the EEPROM during power loss.

**Note:** A JVOP-183 HOA Keypad must be plugged into the drive for settings 1 and 2 to function. If the keypad is removed, b1-12 will automatically be set to 0 (disabled).

| No.   | Parameter Name             | Setting Range | Default |
|-------|----------------------------|---------------|---------|
| b1-12 | Run Delay Memory Selection | 0 to 2        | 2       |

## 5.2 b: Application

---

### Setting 0: Disabled

When the Run Delay Memory Selection (b1-12) is set to 0 (disabled), the Run Delay timer is never saved during power loss. When the drive power is restored, the drive will never apply a b1-11 delay.

### Setting 1: Only at Stop

When b1-12 = 1 (Only at Stop), the Run Delay timer is saved only when the drive is stopped. When the drive is running and it loses power, the drive will not apply a b1-11 delay when power is restored. However, if the drive is stopped with b1-11 counting down and then power is lost, the drive will apply a b1-11 delay based on the time elapsed during the power outage.

### Setting 2: Running & Stop

When b1-12 = 2 (Running & Stop), the Run Delay timer is always saved. When the drive is running and it loses power, the drive will save-off the maximum b1-11 delay time. When power is restored, the drive will apply that time minus the time elapse during the power outage. If the drive is stopped with b1-11 counting down and then power is lost, the drive will apply a b1-11 delay based on the time elapsed during the power outage

## ■ b1-14: Phase Order Selection

Sets the phase order for drive output terminals U/T1, V/T2, and W/T3.

| No.   | Parameter Name        | Setting Range | Default |
|-------|-----------------------|---------------|---------|
| b1-14 | Phase Order Selection | 0 or 1        | 0       |

### Setting 0: Standard Phase Order

### Setting 1: Switched Phase Order

## ■ b1-15: Frequency Reference Selection 2

Refer to *b1-01: Frequency Reference Selection 1 on page 115* for details.

The value set to b1-15 is used as Frequency Reference 2 when one of the multi-function input terminals set for Frequency Reference Switching (H1-□□ = 2) closes.

| No.   | Parameter Name                  | Setting Range | Default |
|-------|---------------------------------|---------------|---------|
| b1-15 | Frequency Reference Selection 2 | 0 to 4        | 0       |

## ■ b1-16: Run Command Selection 2

Refer to *b1-02: Run Command Selection 1 on page 118* for details.

The value set to b1-16 is used as Run Command Source 2 when one of the multi-function input terminals set for Frequency Reference Switching (H1-□□ = 2) closes.

| No.   | Parameter Name          | Setting Range | Default |
|-------|-------------------------|---------------|---------|
| b1-16 | Run Command Selection 2 | 0 to 3        | 0       |

## ■ b1-17: Run Command at Power Up

This parameter is used to determine whether an external Run command that is active during power up of the drive will start the drive or not.

| No.   | Parameter Name          | Setting Range | Default |
|-------|-------------------------|---------------|---------|
| b1-17 | Run Command at Power Up | 0 or 1        | 0       |

### Setting 0: Run Command at Power Up is not Issued

The Run command has to be cycled to start the drive.

**Note:** For safety reasons, the drive is initially set up not to accept a Run command at power up (b1-17 = "0"). If a Run command is issued at power up, the RUN indicator LED will flash quickly. Change parameter b1-17 to 1 if a Run command active at power up shall be accepted by the drive.

### Setting 1: Run Command and Power Up is Issued

An external Run command active during power up is issued and the drive starts to operate the motor as soon as it gets ready for operation (i.e. once the internal start up process is complete).

**WARNING!** Sudden Movement Hazard. If b1-17 is set to 1 and an external Run command is active during power up, the motor will begin rotating as soon as the power is switched on. Proper precautions must be taken to ensure that the area around the motor is safe prior to powering up the drive. Failure to comply may cause serious injury.

## ◆ b2: DC Injection Braking

These parameters determine how the DC Injection Braking/Short Circuit Braking feature operates. Parameters involving the starting frequency, current level, braking time are located here.

### ■ b2-01: DC Injection Braking Start Frequency

Active when "Ramp to Stop" is selected as the stopping method (b1-03 = 0). Sets the starting frequency for DC Injection Braking at Stop.

| No.   | Name                                 | Setting Range  | Default |
|-------|--------------------------------------|----------------|---------|
| b2-01 | DC Injection Braking Start Frequency | 0.0 to 10.0 Hz | 0.5 Hz  |

When the output frequency while ramping to stop drops below b2-01, the drive begins DC Injection/Short Circuit Braking in order to completely stop the motor at the end of deceleration. If b2-01 < E1-09 (Minimum Frequency), then DC Injection/Short Circuit Braking begins at the frequency set to E1-09.

| No.   | Name                     | Setting Range | Default |
|-------|--------------------------|---------------|---------|
| E1-09 | Minimum Output Frequency | 0.0 to E1-04  | 1.5 Hz  |

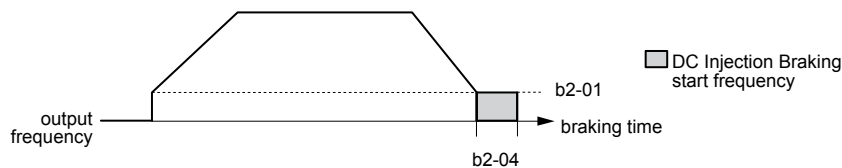


Figure 5.12 DC Injection Braking during Deceleration

### ■ b2-02: DC Injection Braking Current

Sets the DC Injection Braking current as a percentage of the drive rated current. If set to larger than 50%, the carrier frequency is automatically reduced to 1 kHz.

| No.   | Name                         | Setting Range | Default |
|-------|------------------------------|---------------|---------|
| b2-02 | DC Injection Braking Current | 0 to 75%      | 50%     |

The level of DC Injection Braking current affects the strength of the magnetic field attempting to lock the motor shaft. Increasing the current level will increase the amount of heat generated by the motor windings. This parameter should only be increased to the level necessary to hold the motor shaft.

### ■ b2-03: DC Injection Braking Time at Start

Sets the time of DC Injection Braking at start. It can be used to stop a coasting motor before restarting it or to apply a braking torque at start. Disabled when set to 0.00 s.

| No.   | Name                               | Setting Range   | Default |
|-------|------------------------------------|-----------------|---------|
| b2-03 | DC Injection Braking Time at Start | 0.00 to 10.00 s | 0.50 s  |

### ■ b2-04: DC Injection Braking Time at Stop

This parameter works in combination with b2-01, and sets the DC Injection Braking time at stop. Used to completely stop a motor with high inertia load after ramp down. Increase the setting if the motor tends to coast by inertia after a stop.

| No.   | Name                              | Setting Range   | Default |
|-------|-----------------------------------|-----------------|---------|
| b2-04 | DC Injection Braking Time at Stop | 0.00 to 10.00 s | 0.50 s  |

### ■ Speed Estimation Type Speed Search (b3-24 = 1)

This method can be used for a single motor connected to a drive. It should not be utilized if the motor is one or more frame sizes smaller than the drive, at motor speeds above 130 Hz, or when using a single drive to operate more than one motor.

The Speed Estimation type distinguishes two kinds of operation, Back EMF voltage estimation and DC current injection.

#### Back EMF Voltage Estimation

This method is used by Speed Search after short Baseblock (e.g. a power loss where the drives CPU kept running and the Run command was kept active). Here the drive estimates the motor speed by analyzing the back EMF voltage. It outputs the estimated frequency and increases the voltage using the time constant set in parameter L2-04. After that the motor is accelerated or decelerated to the frequency reference starting from the detected speed.

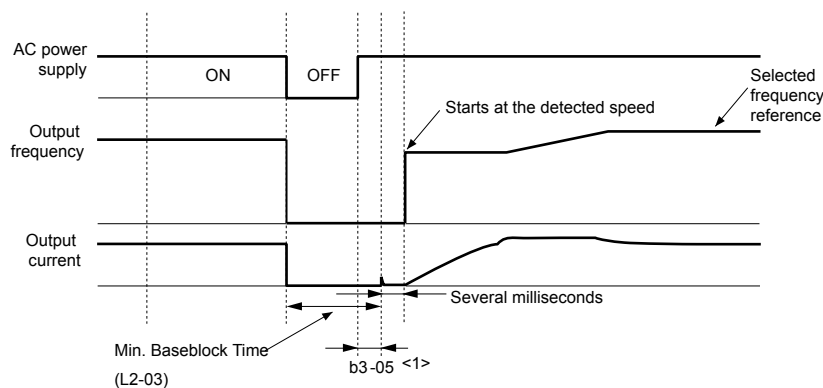


Figure 5.13 Speed Search after Baseblock

<1> Once AC power is restored, the drive will wait for at least the time set to b3-05. If the power interruption is longer than the Minimum Baseblock Time L2-03, the drive will wait for b3-05 after the power has returned before starting Speed Search.

### Current Injection

This method is used when there is no detectable back EMF, e.g. after longer power losses, when Speed Search is applied with the Run command (b3-01 = 1) or if an External Search command is used. It injects the DC current set in b3-06 to the motor and detects the speed by measuring the current feedback. The drive outputs the detected frequency and increases the voltage using the time constant set in parameter L2-04. If the resulting current is higher than the level in b3-02 the output frequency is reduced. When the current becomes lower than b3-02 the motor speed is assumed to be found and the drive starts to accelerate or decelerate to the frequency reference.

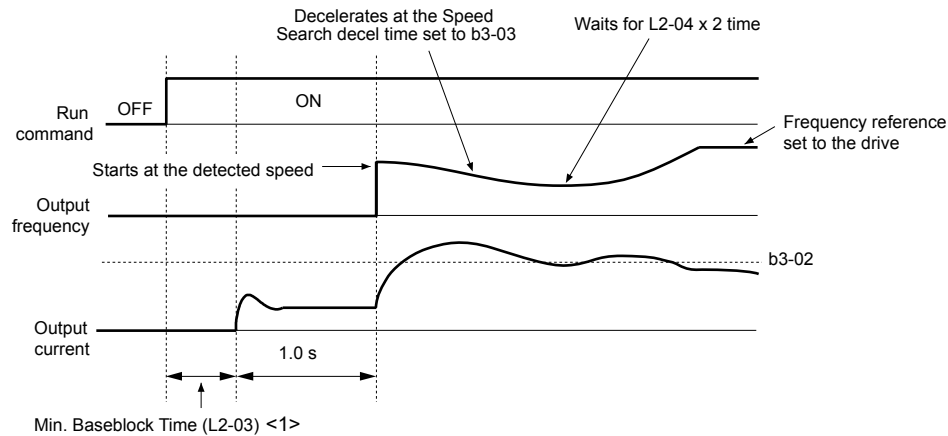


Figure 5.14 Speed Search at Start

<1> The wait time for Speed Search (b3-05) determines the lower limit.

**Note:** If the Run command is quickly switched off and then back on again when the drive is set to “Coast to stop” as the stopping method, Speed Search will operate as shown in [Figure 5.13](#).

### Notes on Using Speed Estimation Type Speed Search

- Auto-Tuning needs to be first performed if you plan to use Speed Estimation. Perform Auto-Tuning again if there is a change in the cable length between the drive and motor.
- Use Current Detection to search for speeds beyond 130 Hz or if the application is running multiple motors from the same drive, or if the motor is considerably smaller than the capacity of the drive.
- Speed Estimation may have trouble finding the actual speed if the motor cable is very long. Current Detection should be used in such situations.
- Use Current Detection instead of Speed Estimation when operating motors smaller than 1.5 kW. Speed Estimation can end up stopping smaller motors as it might not be able to detect the speed or rotation direction of such small motors.

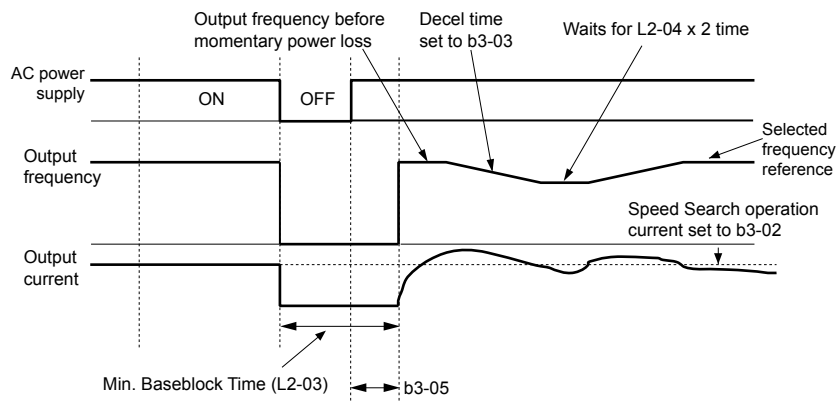
### ■ Current Detection Type Speed Search (b3-24 = 0)

Current Detection Speed Search can be applied to any motor. Be aware that sudden acceleration may occur when using Current Detection with relatively light loads.

This method detects the motor speed by reducing the output frequency and measuring the current. The frequency reduction starts from the maximum output frequency or from the set frequency reference. As long as the output frequency is higher than the rotor speed, the slip will cause a high current. The closer the output frequency comes to the rotor speed, the lower the current draw will be. When the output current drops below the level as set in b3-02, the output frequency stops decreasing and normal operation resumes.

The following time chart illustrates how Current Detection Speed Search operates after a momentary power loss:

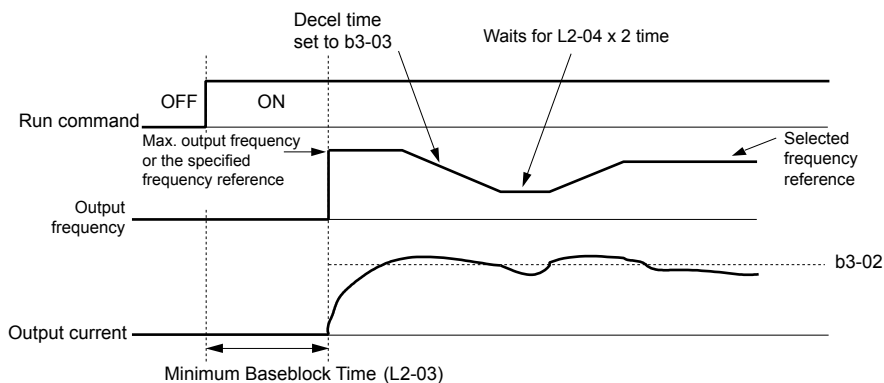
## 5.2 b: Application



**Figure 5.15 Current Detection Speed Search after Power Loss**

**Note:** After power is restored, the drive waits until the time set to b3-05 has passed before performing Speed Search. Thereby the Speed Search may start not at the end of L2-03 but even later.

When Speed Search is applied using an external Search command or automatically with the Run command, the drive waits for the minimum baseblock time L2-03 before Speed Search is started. If L2-03 is smaller than the time set in parameter b3-05, b3-05 is used as the wait time.



**Figure 5.16 Current Detection Speed Search at Start or External Speed Search**

**Note:** When the Run command is set the drive waits until the Speed Search Wait Time (b3-05) before Speed Search is performed, even if the Minimum Baseblock Time is set to smaller values than b3-05.

### Notes on Using Current Detection Type Speed Search

- Increase the voltage recovery ramp time set to L2-04 if a Uv1 fault occurs when performing Current Detection Speed Search.
- Shorten the Speed Search deceleration time set to b3-03 if an oL1 fault occurs while performing Current Detection Speed Search.
- Increase the minimum baseblock time set to L2-03 if an overcurrent fault occurs when performing Speed Search after power is restored following a momentary power loss.

### ■ Activation of Speed Search

Speed Search can be activated as described below. Independent of the activation method the Speed Search type must be selected in parameter b3-24.

1. Automatically at every Run command (*Refer to b3-01: Speed Search Selection at Start on page 127*). With this setting external Speed Search commands are disregarded.
2. By digital inputs:  
The following input functions for H1-□□ can be used.

Table 5.5 Speed Search Activation by Digital Inputs

| Setting | Description               | b3-24 = 0  | b3-24 = 1                              |
|---------|---------------------------|--|--|
| 61      | External Search Command 1 | Closed: Activate Current Detection Speed Search from the maximum output frequency (E1-04).         | Activate Speed Estimation Speed Search |
| 62      | External Search Command 2 | Closed: Activate Current Detection Speed Search from the frequency reference if b3-01 is set to 0. | —                                      |

To activate Speed Search by a digital input the input must always be set together with the Run command.

### 3. After automatic fault restart

Set the number of maximum fault restarts in parameter L5-01 higher than 0.

### 4. After momentary power loss

The following parameter settings are necessary:

Enable Power Loss Ride-Thru selection by setting L2-01 to 1 (enabled) or 2 (enabled during CPU operation). *Refer to L2-01: Momentary Power Loss Operation Selection on page 193.*

Set the number of maximum fault restarts in parameter L5-01 higher than 0.

### 5. After baseblock is released

The drive will resume the operation starting with Speed Search if the Run command is present and the output frequency is above the minimum frequency when the Baseblock command (H1-□□ = 8 or 9, N.O. and N.C., respectively) is released.

## ■ b3-01: Speed Search Selection at Start

Determines if Speed Search is automatically performed when a Run command is issued.

| No.   | Parameter Name                  | Setting Range | Default |
|-------|---------------------------------|---------------|---------|
| b3-01 | Speed Search Selection at Start | 0, 1          | 0       |

### Setting 0: Disabled

This setting starts operating the drive at the minimum output frequency when the Run command is entered. If external Speed Search 1 or 2 is already enabled by a digital input, the drive will start operating with Speed Search.

### Setting 1: Enabled

This setting performs Speed Search when the Run command is entered. The drive begins running the motor after Speed Search is complete.

## ■ b3-02: Speed Search Deactivation Current

Sets Speed Search operating current as a percentage of the drive rated current. If the current falls below this level while performing Current Detection Speed Search then Speed Search will be finished and normal operation will resume. Normally there is no need to change this setting. If the drive won't run after a restart, lower this value.

| No.   | Name                              | Setting Range | Default |
|-------|-----------------------------------|---------------|---------|
| b3-02 | Speed Search Deactivation Current | 0 to 200%     | 120%    |

## ■ b3-03: Speed Search Deceleration Time

Parameter b3-03 sets the output frequency reduction ramp used by Current Detection Speed Search (b3-24 = 0) and by the Current Injection Method of Speed Estimation (b3-24 = 1). The time entered into b3-03 will be the time to decelerate from maximum frequency (E1-04) to minimum frequency (E1-09).

| No.   | Name                           | Setting Range | Default |
|-------|--------------------------------|---------------|---------|
| b3-03 | Speed Search Deceleration Time | 0.1 to 10.0 s | 2.0 s   |

## ■ b3-05: Speed Search Delay Time

In cases where an output contactor is used between the drive and the motor, the contactor must be closed before Speed Search can be performed. For Speed Search after a momentary power loss, parameter b3-05 can be used to delay the Speed Search start providing enough time to operate the contactor.

When Speed Search at start is used, b3-05 will serve as the lower limit of the minimum baseblock time (L2-03).

## 5.2 b: Application

| No.   | Name                    | Setting Range  | Default |
|-------|-------------------------|----------------|---------|
| b3-05 | Speed Search Delay Time | 0.0 to 100.0 s | 0.2 s   |

### ■ b3-06: Output Current 1 During Speed Search

Sets the current injected to the motor at the beginning of Estimation Type Speed Search as a factor related to motor rated current set in E2-01 and E4-01. If the motor speed is relatively slow when the drive starts to perform Speed Search after a long period of baseblock, it may be helpful to increase the setting value. The output current during Speed Search is automatically limited by the drive rated current. This function has no influence when Current Detection Speed Search is used (b3-24 = 0).

| No.   | Name                                 | Setting Range | Default             |
|-------|--------------------------------------|---------------|---------------------|
| b3-06 | Output Current 1 during Speed Search | 0.0 to 2.0    | Determined by o2-04 |

**Note:** If Speed Estimation is not working correctly even after adjusting b3-06, try using Current Detection Speed Search instead.

### ■ b3-08: Current Control Gain during Speed Search (Speed Estimation Type)

Sets the proportional gain for the current controller during Speed Search. There is normally no need to change this parameter from the default value.

| No.   | Name   | Setting Range | Default |
|-------|--|---------------|---------|
| b3-08 | Current Control Gain during Speed Search (Speed Estimation Type) | 0.00 to 6.00  | 0.50    |

### ■ b3-10: Speed Search Detection Compensation Gain

This parameter sets the gain for the detected motor speed of the Speed Estimation Speed Search. The drive will start the motor at the estimated speed multiplied by b3-10. The setting should be increased if an overvoltage fault occurs when the drive restarts the motor. This function has no influence when Current Detection Speed Search is used (b3-24 = 0).

| No.   | Name                                     | Setting Range | Default |
|-------|--|---------------|---------|
| b3-10 | Speed Search Detection Compensation Gain | 1.00 to 1.20  | 1.10    |

**Note:** Increase this value if overvoltage occurs when performing Speed Search at start after a relatively long period of baseblock.

### ■ b3-14: Bi-Directional Speed Search Selection

Sets how the drive determines the motor rotation direction when performing Speed Estimation Speed Search. The setting has no influence on Current Detection Speed Search (b3-24 = 0).

| No.   | Parameter Name                        | Setting Range | Default |
|-------|---------------------------------------|---------------|---------|
| b3-14 | Bi-Directional Speed Search Selection | 0 or 1        | 0       |

#### Setting 0: Disabled

The drive uses the frequency reference to determine the direction of motor rotation in order to restart the motor.

#### Setting 1: Enabled

The drive detects the motor rotation direction in order to restart the motor.

### ■ b3-17: Speed Search Restart Current Level

If there is a fairly large difference between the estimated frequency and the actual motor speed when performing Speed Estimation, a large current can flow. This parameter sets the current level at which Speed Estimation is restarted, thus avoiding overcurrent and overvoltage problems. The parameter is set as a percentage of the drive rated current. This function has no influence when Current Detection Speed Search is used (b3-24 = 0).

| No.   | Name                               | Setting Range | Default |
|-------|------------------------------------|---------------|---------|
| b3-17 | Speed Search Restart Current Level | 0 to 200%     | 150%    |

### ■ b3-18: Speed Search Restart Detection Time

Sets the time the current must be above the level set in b3-17 before Speed Search is restarted. This function has no influence when Current Detection Speed Search is used (b3-24 = 0)

| No.   | Name                                | Setting Range  | Default |
|-------|-------------------------------------|----------------|---------|
| b3-18 | Speed Search Restart Detection Time | 0.00 to 1.00 s | 0.10 s  |



### ■ b3-19: Number of Speed Search Restarts

Sets the number of times the drive should attempt to find the speed and restart the motor using Speed Estimation Speed Search. This function has no influence when Current Detection Speed Search is used (b3-24 = 0).

| No.   | Name                            | Setting Range | Default |
|-------|---------------------------------|---------------|---------|
| b3-19 | Number of Speed Search Restarts | 0 to 10       | 3       |

### ■ b3-24: Speed Search Method Selection

Sets the Speed Search method used.

**Note:** For explanations of the Speed Search methods, *Refer to Current Detection Type Speed Search (b3-24 = 0) on page 125* and *Refer to Speed Estimation Type Speed Search (b3-24 = 1) on page 124*.

| No.   | Parameter Name                | Setting Range | Default |
|-------|-------------------------------|---------------|---------|
| b3-24 | Speed Search Method Selection | 0 or 1        | 0       |

#### Setting 0: Current Detection Speed Search

#### Setting 1: Speed Estimation Speed Search

### ■ b3-25: Speed Search Wait Time

Sets the wait time between Speed Search restarts.

| No.   | Name                   | Setting Range | Default |
|-------|------------------------|---------------|---------|
| b3-25 | Speed Search Wait Time | 0.0 to 30.0 s | 0.5 s   |

## ◆ b4: Delay Timers

The timer function is independent of the drive operation and can be used to delay the switching of a digital output triggered by a digital input signal. An On-delay and Off-delay can be separately set. The delay timer can help to get rid of chattering switch noise from sensors.

To enable the timer function, a multi-function input must be set to “Timer input” (H1-□□ = 18) and a multi-function output must be set to “Timer output” (H2-□□ = 12). Only one timer can be used.

### ■ b4-01/b4-02: Timer Function On/Off-Delay Time

b4-01 sets the On-delay time for switching the timer output. b4-02 sets the Off-delay time for switching the timer output.

| No.   | Name                          | Setting Range  | Default |
|-------|-------------------------------|----------------|---------|
| b4-01 | Timer Function On-Delay Time  | 0.0 to 300.0 s | 0.0 s   |
| b4-02 | Timer Function Off-Delay Time | 0.0 to 300.0 s | 0.0 s   |

### ■ Timer Function Operation

When the timer function input closes for longer than the value set in b4-01, the timer output switches on. When the timer function input is open for longer than the value set in b4-02, the timer output function switches off. The following diagram demonstrates the timer function operation.

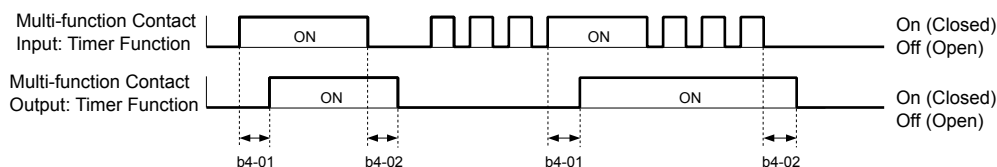


Figure 5.17 Timer Operation

## ◆ b5: PID Control

The drive has a built in PID (Proportional + Integral + Derivative) controller that can be used for closed loop control of system variables such as pressure, temperature etc. The difference between the target and the feedback value (deviation) is fed into the PID controller. The PID controller adjusts the drive output frequency in order to minimize the deviation, providing an accurate control of the system variables.

## 5.2 b: Application

### ■ P Control

The output of P control is the product of the deviation and the P gain so that it follows the deviation directly and linearly. With P control only an offset between the target and feedback remains.

### ■ I Control

The output of I control is the integral of the deviation. It minimizes the offset between target and feedback value that typically remains when pure P control is used. The integral time (I-time) constant determines how fast the offset is eliminated.

### ■ D Control

D control predicts the deviation signal by multiplying its derivative (slope of the deviation) with a time constant and adding this to the PID input. This way the D portion of a PID controller provides a braking action to the controller response and can reduce the tendency of oscillations and overshoot.

Be aware that D control tends to amplify noise on the deviation signal, which can result in control instability. D control should therefore only be used when necessary.

### ■ PID Operation

To better demonstrate how PID works, the diagram below shows how the PID output changes when the PID input (deviation) jumps from 0 to a constant level.

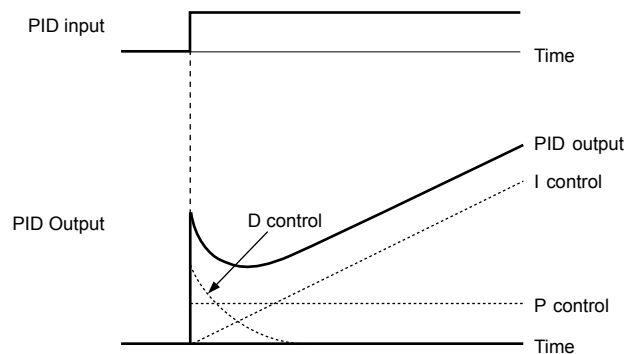


Figure 5.18 PID Operation

### ■ Using PID Control

Applications for PID control are listed in the table below.

| Application         | Description   | Sensors Used              |
|---------------------|---|---------------------------|
| Speed Control       | Machinery speed is fed back and adjusted to meet the target value. Synchronous control is performed using speed data from other machinery as the target value | Tachometer                |
| Pressure            | Maintains constant pressure using pressure feedback.  | Pressure sensor           |
| Fluid Control       | Keeps flow at a constant level by feeding back flow data.   | Flow rate sensor          |
| Temperature Control | Maintains a constant temperature by controlling a fan with a thermostat.  | Thermocoupler, Thermistor |

## ■ PID Setpoint Input Methods

When the PID control parameter b5-01 is set to 1 or 2, the frequency reference in b1-01 (or b1-15) becomes the PID setpoint. If b5-01 is set to 3 or 4, then the PID setpoint can be input from one of the sources in the following table.

**Table 5.6 PID Setpoint Sources**

| PID Setpoint Source           | Settings  |
|-------------------------------|---|
| Analog Input A1               | Set H3-02 = C   |
| Analog Input A2               | Set H3-10 = C   |
| MEMOBUS/Modbus Register 0006H | Set Bit 1 in register 000FH to 1 and input the setpoint to register 0006H |
| Pulse Input RP                | Set H6-01 = 2   |
| Parameter b5-19               | Set parameter b5-18 = 1 and input the PID setpoint to b5-19               |

**Note:** A duplicate allocation of the PID setpoint input will result in an OPE alarm.

## ■ PID Feedback Input Methods

Either one feedback signal can be input for normal PID control or two feedback signals can be input for controlling a differential process value.

### Normal PID Feedback

The PID feedback can be input from one of the sources listed below.

**Table 5.7 PID Feedback Sources**

| PID Feedback Source | Settings      |
|---------------------|---------------|
| Analog Input A1     | Set H3-02 = B |
| Analog Input A2     | Set H3-10 = B |
| Pulse Input RP      | Set H6-01 = 1 |

**Note:** A duplicate allocation of the PID feedback input will result in an OPE alarm.

### Differential Feedback

The second PID feedback signal for differential feedback can come from the sources listed below. The differential feedback function is automatically enabled when a differential feedback input is assigned.

**Table 5.8 PID Differential Feedback Sources**

| PID Differential Feedback Source | Settings       |
|----------------------------------|----------------|
| Analog Input A1                  | Set H3-02 = 16 |
| Analog Input A2                  | Set H3-10 = 16 |

**Note:** A duplicate allocation of the PID differential feedback input will result in an OPE alarm.

■ PID Block Diagram

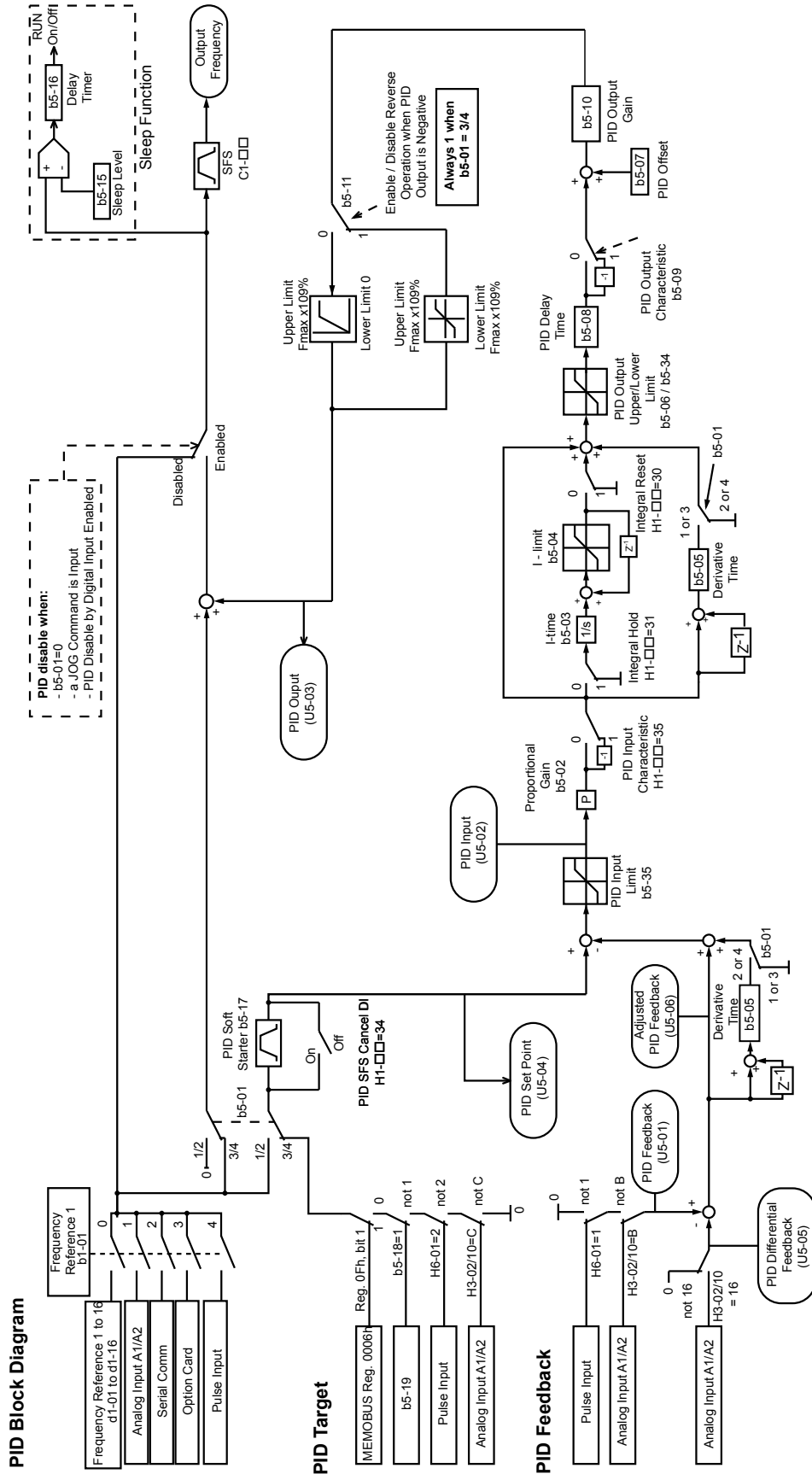


Figure 5.19 PID Block Diagram

### ■ b5-01: PID Function Setting

Enables or disables the PID operation and selects the PID operation mode.

| No.   | Parameter Name       | Setting Range | Default |
|-------|----------------------|---------------|---------|
| b5-01 | PID Function Setting | 0 to 4        | 0       |

#### Setting 0: PID disabled

#### Setting 1: Output Frequency = PID Output 1

The PID controller is enabled and the PID output builds the frequency reference. The PID input is D controlled.

#### Setting 2: Output Frequency = PID Output 2

The PID controller is enabled and the PID output builds the frequency reference. The PID feedback is D controlled.

#### Setting 3: Output Frequency = Frequency Reference + PID Output 1

The PID controller is enabled and the PID output is added to the frequency reference. D control is applied to the difference of the feedback value (U5-02) and the setpoint.

#### Setting 4: Output Frequency = Frequency Reference + PID Output 2

The PID controller is enabled and the PID output is added to the frequency reference. Applies D control on the feedback value (U5-06).

### ■ b5-01: PID Function Setting

Enables and disables the PID operation and selects the PID operation mode.

| No.   | Parameter Name       | Setting Range | Default |
|-------|----------------------|---------------|---------|
| b5-01 | PID Function Setting | 0, 1          | 1       |

#### Setting 0: PID disabled

#### Setting 1: Output frequency = PID output 1

The PID controller is enabled and the PID output builds the frequency reference. The PID input is D controlled.

### ■ b5-02: Proportional Gain Setting (P)

Sets the P gain that is applied to the PID input. A large value will tend to reduce the error, but may cause instability (oscillations) if too high. A small value may allow too much offset between the setpoint and feedback.

| No.   | Name                          | Setting Range | Default |
|-------|-------------------------------|---------------|---------|
| b5-02 | Proportional Gain Setting (P) | 0.00 to 25.00 | 2.00    |

### ■ b5-03: Integral Time Setting (I)

Sets the time constant used to calculate the integral of the PID input. The shorter the integral time set to b5-03, the faster the offset will be eliminated. If the integral time is set too short, however, overshoot or oscillation may occur. To turn off the integral time, set b5-03 to 0.00.

| No.   | Name                      | Setting Range  | Default |
|-------|---------------------------|----------------|---------|
| b5-03 | Integral Time Setting (I) | 0.0 to 360.0 s | 3.0 s   |

### ■ b5-09: PID Output Level Selection

Reverses the sign of the PID controller output signal. Normally a positive PID input (feedback smaller than setpoint) leads to positive PID output.

| No.   | Parameter Name             | Setting Range | Default |
|-------|----------------------------|---------------|---------|
| b5-09 | PID Output Level Selection | 0, 1          | 0       |

#### Setting 0: Direct Acting

A positive PID input causes an increase in the PID output (direct acting).

#### Setting 1: Inverse Acting

A positive PID input causes a decrease in the PID output (reverse acting).

## 5.2 b: Application

### ■ b5-04: Integral Limit Setting

Sets the maximum output possible from the integral block. Set as a percentage of the maximum frequency (E1-04).

| No.   | Name                   | Setting Range | Default |
|-------|------------------------|---------------|---------|
| b5-04 | Integral Limit Setting | 0.0 to 100.0  | 100.0   |

**Note:** On some applications, especially those with rapidly varying loads, the output of the PID function may show a fair amount of oscillation. To suppress this oscillation, a limit can be applied to the integral output by programming b5-04.

### ■ b5-05: Derivative Time (D)

Sets the time the drive predicts the PID input/PID feedback signal based on the derivative of the PID input/PID feedback. Longer time settings will improve the response but can cause vibrations. Shorter settings will reduce the overshoot but also reduce the controller responsiveness. D control is disabled by setting b5-05 to zero seconds.

| No.   | Name            | Setting Range   | Default |
|-------|-----------------|-----------------|---------|
| b5-05 | Derivative Time | 0.00 to 10.00 s | 0.00 s  |

### ■ b5-06: PID Output Limit

Sets the maximum output possible from the entire PID controller. Set as a percentage of the maximum frequency (E1-04).

| No.   | Name             | Setting Range | Default |
|-------|------------------|---------------|---------|
| b5-06 | PID Output Limit | 0.0 to 100.0% | 100.0%  |

### ■ b5-07: PID Offset Adjustment

Sets the offset added to the PID controller output. Set as a percentage of the maximum frequency.

| No.   | Name                  | Setting Range    | Default |
|-------|-----------------------|------------------|---------|
| b5-07 | PID Offset Adjustment | -100.0 to 100.0% | 0.0%    |

### ■ b5-08: PID Primary Delay Time Constant

Sets the time constant for the filter applied to the output of the PID controller. Normally, change is not required.

| No.   | Name                            | Setting Range   | Default |
|-------|---------------------------------|-----------------|---------|
| b5-08 | PID Primary Delay Time Constant | 0.00 to 10.00 s | 0.00 s  |

**Note:** Effective in preventing oscillation when there is a fair amount of oscillation or when rigidity is low. Set to a value larger than the cycle of the resonant frequency. Increasing this time constant reduces the responsiveness of the drive.

### ■ b5-09: PID Output Level Selection

Normally, the output of the PID function increase whenever the PID input is negative (feedback below setpoint). Using b5-09 the PID controller can be set up for applications that require opposite operation.

| No.   | Parameter Name             | Setting Range | Default |
|-------|----------------------------|---------------|---------|
| b5-09 | PID Output Level Selection | 0 or 1        | 0       |

#### Setting 0: Normal Output

A negative PID input causes an increase in the PID output (direct acting).

#### Setting 1: Reverse Output

A negative PID input causes a decrease in the PID output (reverse acting).

### ■ b5-10: PID Output Gain Setting

Applies a gain to the PID output and can be helpful when the PID function is used to trim the frequency reference (b5-01 = 3 or 4). Increasing b5-10 causes the PID function to have a greater regulating effect on the frequency reference.

| No.   | Name                    | Setting Range | Default |
|-------|-------------------------|---------------|---------|
| b5-10 | PID Output Gain Setting | 0.00 to 25.00 | 1.00    |

### ■ b5-11: PID Output Reverse Selection

Determines whether a negative PID output reverses the drive operation direction or not. When the PID function is used to trim the frequency reference (b5-01 = 3 or 4), this parameter has no effect and the PID output will not be limited (same as

b5-11 = 1).

| No.   | Parameter Name               | Setting Range | Default |
|-------|------------------------------|---------------|---------|
| b5-11 | PID Output Reverse Selection | 0 or 1        | 0       |

#### Setting 0: Reverse Disabled

Negative PID output will be limited to 0 and the drive output will be stopped.

#### Setting 1: Reverse Enabled

Negative PID output will cause the drive to run in the opposite direction.

### ■ PID Feedback Loss Detection

The PID Feedback Loss Detection function can detect broken sensors or broken sensor wiring. It should be used whenever PID control is enabled to prevent critical machine conditions (e.g. acceleration to max. frequency) caused by a feedback loss.

Feedback loss can be detected in two ways:

- **Feedback Low Detection:**

Detected when the feedback falls below a certain level for longer than the specified time.

- **Feedback High Detection:**

Detected when the feedback rises beyond a certain level for longer than the specified time.

The following figure explains the working principle of feedback loss detection when the feedback signal is too low. Feedback high detection works in the same way.

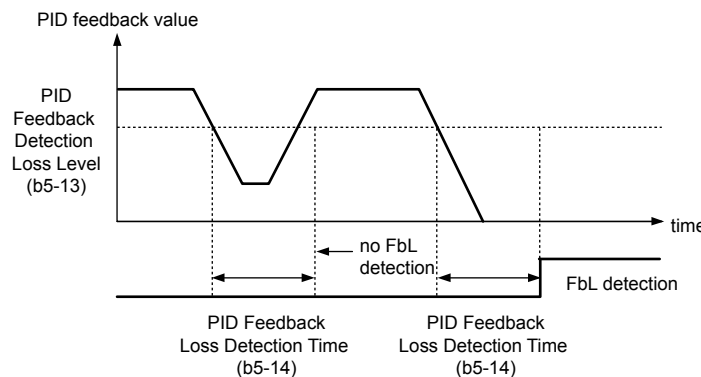


Figure 5.20 PID Feedback Loss Detection

The parameters necessary to set up the feedback loss detection are explained below.

### ■ b5-12: PID Feedback Loss Detection Selection

Enables or disables the feedback loss detection and sets the operation when a feedback loss is detected.

| No.   | Parameter Name                        | Setting Range | Default |
|-------|---------------------------------------|---------------|---------|
| b5-12 | PID Feedback Loss Detection Selection | 0 to 5        | 0       |

#### Setting 0: Digital Output Only

A digital output set for “PID feedback low” (H2-□□ = 3E) will be triggered if the PID feedback value is below the detection level set to b5-13 for the time set to b5-14 or longer. A digital output set for “PID feedback high” (H2-□□ = 3F) will be triggered if the PID feedback value is beyond the detection level set to b5-36 for the time set to b5-37 or longer. Neither a fault nor an alarm is displayed on the digital operator. The drive will continue operation. When the feedback value leaves the loss detection range, the output is reset.

#### Setting 1: Feedback Loss Alarm

If the PID feedback value falls below the level set to b5-13 for longer than the time set to b5-14, a “FBL - Feedback Low” alarm will be displayed and a digital output set for “PID feedback low” (H2-□□ = 3E) will be triggered. If the PID feedback value exceeds the level set to b5-36 for longer than the time set to b5-37, a “FBH - Feedback High” alarm will be displayed and a digital output set for “PID feedback high” (H2-□□ = 3F) will be triggered. Both events trigger an alarm output (H1-□□ = 10). The drive will continue operation. When the feedback value leaves the loss detection range, the alarm and outputs are reset.

## 5.2 b: Application

### Setting 2: Feedback Loss Fault

If the PID feedback value falls below the level set to b5-13 for longer than the time set to b5-14, a “FBL - Feedback Low” fault will be displayed. If the PID feedback value exceeds the level set to b5-36 for longer than the time set to b5-37, a “FBH - Feedback High” fault will be displayed. Both events trigger a fault output (H1-□□ = E) and cause the drive to stop the motor.

### Setting 3: Digital Output Only, Even if PID is Disabled by Digital Input

Same as b5-12 = 0. Detection is still active even if PID is disabled by a digital input (H1-□□ = 19).

### Setting 4: Feedback Loss Alarm, Even if PID is Disabled by Digital Input

Same as b5-12 = 1. Detection is still active even if PID is disabled by a digital input (H1-□□ = 19).

### Setting 5: Feedback Loss Fault, Even if PID is Disabled by Digital Input

Same as b5-12 = 2. Detection is still active even if PID is disabled by a digital input (H1-□□ = 19).

### ■ b5-13: PID Feedback Loss Detection Level

Sets the feedback level used for PID feedback loss detection. The PID feedback has to fall below this level for longer than the time b5-14 before feedback loss is detected.

| No.   | Name                              | Setting Range | Default |
|-------|-----------------------------------|---------------|---------|
| b5-13 | PID Feedback Loss Detection Level | 0 to 100%     | 0%      |

### ■ b5-14: PID Feedback Loss Detection Time

Sets the time that the PID feedback has to fall below b5-13 before feedback loss is detected.

| No.   | Name                             | Setting Range | Default |
|-------|----------------------------------|---------------|---------|
| b5-14 | PID Feedback Loss Detection Time | 0.0 to 25.5 s | 1.0 s   |

### ■ PID Sleep

The PID Sleep function stops the drive when the PID output or the frequency reference falls below the PID Sleep operation level for a certain time. The drive will resume operating once the PID output or frequency reference rises above the PID Sleep operation level for the specified time. The operation is explained in the figure below.

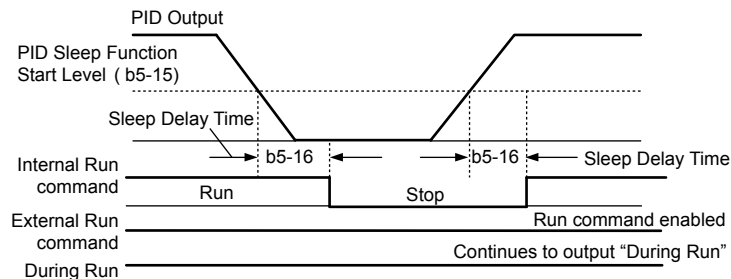


Figure 5.21 PID Sleep Operation

#### Notes on using the PID Sleep function:

- The PID Sleep function is always active, even if PID control is disabled.
- The method the Sleep function uses to stop the motor is defined by parameter b1-03.
- The parameters necessary to set up the PID Sleep function are explained below.

### ■ b5-15: PID Sleep Function Start Level

Sets the level used for PID Sleep.

The drive goes into Sleep mode if the PID output or frequency reference is smaller than b5-15 for longer than the time set in b5-16. It resumes the operation when the PID output or frequency reference is above b5-15 for longer than the time set in b5-16.

| No.   | Name                           | Setting Range   | Default |
|-------|--------------------------------|-----------------|---------|
| b5-15 | PID Sleep Function Start Level | 0.0 to 400.0 Hz | 0.0 Hz  |



### ■ b5-16: PID Sleep Delay Time

Sets the delay time to activate or deactivate the PID Sleep function.

| No.   | Name                 | Setting Range | Default |
|-------|----------------------|---------------|---------|
| b5-16 | PID Sleep Delay Time | 0.0 to 25.5 s | 0.0 s   |

### ■ b5-17: PID Accel/Decel Time

The PID acceleration/deceleration time is applied on the PID setpoint value.

As the normal acceleration times C1-□□ are applied after the PID output, they reduce the responsiveness of the system and can cause hunting or over- and undershooting when the setpoint changes quickly. Using the PID acceleration/deceleration time instead helps to avoid such problems.

The PID acceleration/deceleration time can be canceled using a digital input programmed for “PID SFS cancel” (H1-□□ = 34).

| No.   | Name                 | Setting Range | Default |
|-------|----------------------|---------------|---------|
| b5-17 | PID Accel/Decel Time | 0 to 255 s    | 0 s     |

### ■ b5-32: Integrator Ramp Limit

The Integrator Ramp Limit provides a way to tune the PI loop so that it is less reactive to sudden spikes and dips in the feedback signal. Pressure waves may develop in a pressure regulated systems with long piping and the Integrator Ramp Limit function helps curb instability in the PI controller in such situations.

When the Integrator Ramp Limit is enabled, the PI Integrator is limited to +/- the b5-32 value of the soft starter output (output frequency without slip compensation).

A b5-32 setting of zero disables this feature and the integrator is allowed to operate normally.

This feature only applies to the drive standard PI loop. It does not apply to the PI loop associated with the water level control function (well draw-down control) (Q4 parameters).

| No.   | Name                  | Setting Range  | Default |
|-------|-----------------------|----------------|---------|
| b5-32 | Integrator Ramp Limit | 0.0 to 10.0 Hz | 0.0 Hz  |

### ■ b5-34: PID Output Lower Limit

Sets the minimum possible PID controller output as a percentage of the maximum output frequency (E1-04). The lower limit is disabled when set to 0.00%

| No.   | Name                   | Setting Range    | Default |
|-------|------------------------|------------------|---------|
| b5-34 | PID Output Lower Limit | -100.0 to 100.0% | 0.00%   |

### ■ b5-35: PID Input Limit

Sets the maximum allowed PID input as a percentage of the maximum output frequency (E1-04). Parameter b5-35 acts as a bipolar limit.

| No.   | Name            | Setting Range  | Default |
|-------|-----------------|----------------|---------|
| b5-35 | PID Input Limit | 0.0 to 1000.0% | 1000.0% |

### ■ b5-39: PID System Units Display Digits

Determines the number of digits for the user-defined display for the PID setpoint (Q1-□□) and PID feedback monitors (U5-01, U5-04). The setting value is equal to the number of decimal places.

| No.   | Name                            | Setting Range | Default |
|-------|---------------------------------|---------------|---------|
| b5-39 | PID System Units Display Digits | 0 to 3        | 1       |

## 5.2 b: Application

**Setting 0: No Decimal Places**

**Setting 1: One Decimal Place**

**Setting 2: Two Decimal Places**

**Setting 3: Three Decimal Places**

### ■ b5-40: Frequency Reference Monitor Content During PID

Sets the content on the frequency reference monitor display (U1-01) when PID control is active.

| No.   | Name   | Setting Range | Default |
|-------|--|---------------|---------|
| b5-40 | Frequency Reference Monitor Content During PID | 0 or 1        | 0       |

### Setting 0: Frequency Reference after PID

Monitor U1-01 displays the frequency reference increased or reduced for the PID output.

### Setting 1: Frequency Reference

Monitor U1-01 displays the frequency reference value.

### ■ b5-47: Reverse Operation Selection 2 by PID Output

Reverses operation selection when b5-01 is set to 3 or 4.

| No.   | Name  | Setting Range | Default |
|-------|---|---------------|---------|
| b5-47 | Reverse Operation Selection 2 by PID Output | 0 or 1        | 1       |

### Setting 0: Zero Limit when PID Output is a Negative Value

**Setting 1: Reverse Operation when PID Output is a Negative Value (Zero Limit if the Reverse Operation Is Prohibited by b1-04)**

## ◆ b6: Dwell Function

The reference hold or Dwell function is used to temporarily hold the output frequency at a set reference value, for a set time, and then continue to ramp up or stop.

The Dwell at start function can be used when driving a permanent magnet motor in V/f Control, or a motor with a heavy starting load. The pause in acceleration allows the PM motor rotor to align with the stator field of the motor, thus reducing the starting current.

Dwell works as shown in the figure below.

**Note:** Using the Dwell function requires that the stopping method for the drive be set to “Ramp to Stop” (b1-03 = 0).

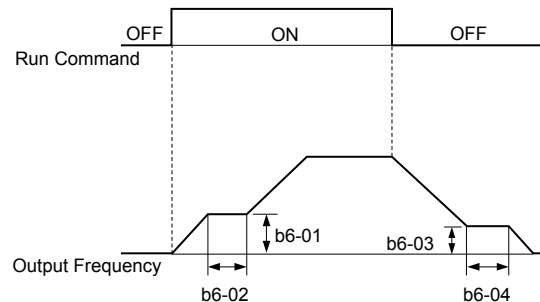


Figure 5.22 Dwell Function at Start and Stop

### ■ b6-01/b6-02: Dwell Reference/Time at Start

b6-01 sets the frequency that is kept for the time set in b6-02 during acceleration.

| No.   | Name                     | Setting Range   | Default |
|-------|--------------------------|-----------------|---------|
| b6-01 | Dwell Reference at Start | 0.0 to 400.0 Hz | 0.0 Hz  |
| b6-02 | Dwell Time at Start      | 0.0 to 10.0 s   | 0.0 s   |

**■ b6-03/b6-04: Dwell Reference/Time at Stop**

Parameter b6-03 sets the frequency that is kept for the time set in b6-04 during deceleration.

| No.   | Name                    | Setting Range   | Default |
|-------|-------------------------|-----------------|---------|
| b6-03 | Dwell Reference at Stop | 0.0 to 400.0 Hz | 0.0 Hz  |
| b6-04 | Dwell Time at Stop      | 0.0 to 10.0 s   | 0.0 s   |

## 5.3 C: Tuning

C parameters are used to set the acceleration and deceleration characteristics, as well as S-curves. Other parameters in this group cover settings for slip compensation, torque compensation, and carrier frequency.

### ◆ C1: Acceleration and Deceleration Times

#### ■ C1-01 to C1-04: Accel, Decel Times 1 and 2

Two different sets of acceleration and deceleration times can be set in the drive by digital inputs, motor selection, or switched automatically.

Acceleration time parameters always set the time to accelerate from 0 Hz to the maximum output frequency (E1-04). Deceleration time parameters always set the time to decelerate from maximum output frequency to 0 Hz. C1-01 and C1-02 are the default active accel/decel settings.

| No.   | Parameter Name      | Setting Range       | Default |
|-------|---------------------|---------------------|---------|
| C1-01 | Acceleration Time 1 | 0.0 to 6000.0 s <1> | 20.0 s  |
| C1-02 | Deceleration Time 1 |                     | 10.0 s  |
| C1-03 | Acceleration Time 2 |                     |         |
| C1-04 | Deceleration Time 2 |                     |         |

<1> The setting range for the acceleration and deceleration times is determined by the accel/decel time setting units in C1-10. For example, if the time is set in units of 0.01 s (C1-10 = 0), the setting range becomes 0.00 to 600.00 s.

#### Switching Acceleration Times by Digital Input

Accel/decel time 1 is active by default if no input is set. Activate accel/decel times 2, 3, and 4 by digital inputs (H1-□□ = 7 and 1A) as explained in [Table 5.9](#).

Table 5.9 Accel/Decel Time Selection by Digital Input

| Accel/Decel Time Sel. 1<br>H1-□□ = 7 | Accel/Decel Time Sel. 2<br>H1-□□ = 1A | Active Times |              |
|--------------------------------------|---------------------------------------|--------------|--------------|
|                                      |                                       | Acceleration | Deceleration |
| 0                                    | 0                                     | C1-01        | C1-02        |
| 1                                    | 0                                     | C1-03        | C1-04        |

[Figure 5.23](#) shows an operation example for changing accel/decel times. The example below requires that the stopping method be set for “Ramp to stop” (b1-03 = 0).

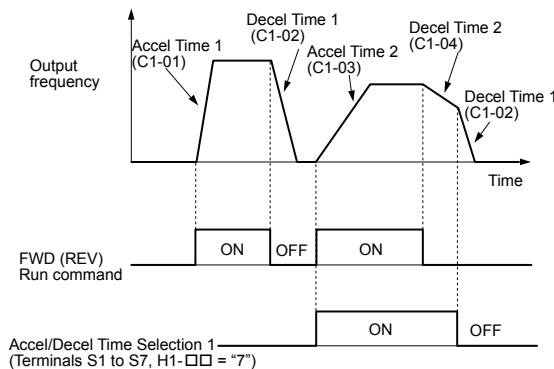


Figure 5.23 Timing Diagram of Accel/Decel Time Change

#### ■ C1-09: Fast-stop Time

Parameter C1-09 will set a special deceleration that is used when certain faults occur or that can be operated by closing a digital input configured as H1-□□ = 15 (N.O. input) or H1-□□ = 17 (N.C. input). The input does not have to be closed continuously, even a momentary closure will trigger the Fast-stop operation.

Unlike standard deceleration, once the Fast-stop operation is initiated, the drive cannot be restarted until the deceleration is complete, the Fast-stop input is cleared, and the Run command is cycled.

A digital output programmed for “During Fast-stop” (H2-01/02/03 = 4C) will be closed as long as Fast-stop is active.

| No.   | Parameter Name | Setting Range       | Default |
|-------|----------------|---------------------|---------|
| C1-09 | Fast-stop Time | 0.0 to 6000.0 s <I> | 10.0 s  |

<I> The setting range for the acceleration and deceleration times is determined by C1-10 (Accel/Decel Time Setting Units). For example, if the time is set in units of 0.01 s (C1-10 = 0), the setting range becomes 0.00 to 600.00 s

**NOTICE:** Rapid deceleration can trigger an overvoltage fault. When faulted, the drive output shuts off, and the motor coasts. To avoid this uncontrolled motor state and to ensure that the motor stops quickly and safely, set an appropriate Fast-stop time to C1-09.

### ■ C1-10: Accel/Decel Time Setting Units

Determines the units for the acceleration and deceleration times set to C1-01 through C1-09 using parameter C1-10.

| No.   | Parameter Name                 | Setting Range | Default |
|-------|--------------------------------|---------------|---------|
| C1-10 | Accel/Decel Time Setting Units | 0 or 1        | 1       |

#### Setting 0: 0.01 s Units

The accel/dec. times are set in 0.01 s units. The setting range will be 0.00 to 600.00 s. If any of the parameters C1-01 to C1-09 is set to 600.1 seconds or more, then C1-10 cannot be set to 0.

#### Setting 1: 0.1 s Units

The accel/dec. times are set in 0.1 s units. The setting range will be 0.0 to 6000.0 s.

### ■ C1-11: Accel/Decel Switch Frequency

Sets the switching frequency for automation accel/dec. time change over.

| No.   | Parameter Name               | Setting Range   | Default |
|-------|------------------------------|-----------------|---------|
| C1-11 | Accel/Decel Switch Frequency | 0.0 to 400.0 Hz | 0.0 Hz  |

**Note:** Setting C1-11 to 0.0 Hz disables this function.

### ■ C1-14: Accel/Decel Rate Frequency

Sets the base frequency used to calculate acceleration and deceleration times.

| No.   | Parameter Name             | Setting Range   | Default |
|-------|----------------------------|-----------------|---------|
| C1-14 | Accel/Decel Rate Frequency | 0.0 to 400.0 Hz | 0.0 Hz  |

**Note:** The accel/dec. rates set to parameters C1-01 to C1-09 change in response to the value set to C1-14.

#### When C1-14 = 0.0 Hz

Operation example is shown in [Figure 5.24](#).

- Accel Times 1 through 4 determine the time required to accelerate from 0 to the maximum output frequency (E1-04)
- Decel Times 1 through 4 and the Fast-stop Time determine the time required to decelerate from the Maximum Output Frequency (E1-04) to 0 Hz.

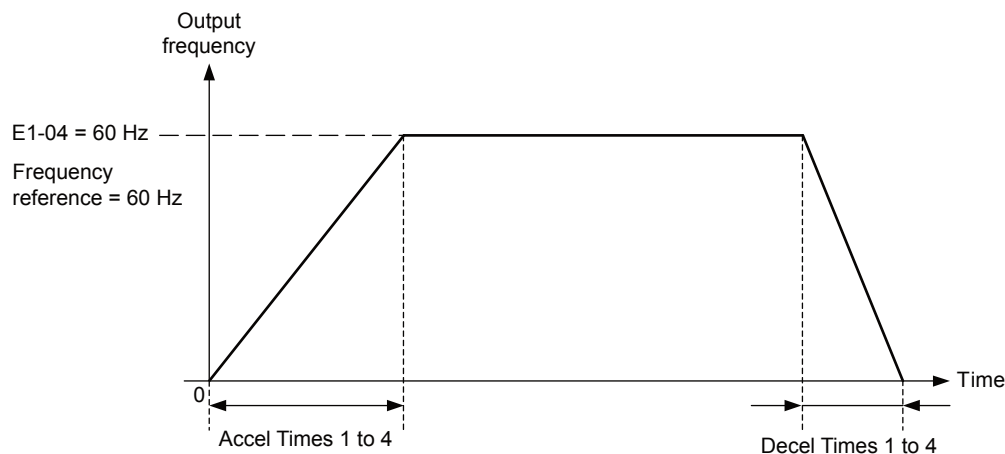


Figure 5.24 Accel/Decel Rate, Example 1 (C1-14 = 0 Hz, E1-04 = 60 Hz, Frequency Reference = 60 Hz)

#### When C1-14 ≠ 0.0 Hz

Operation examples are shown in [Figure 5.25](#) and [Figure 5.26](#).

## 5.3 C: Tuning

- Accel Times 1 through 4 determine the time required to accelerate from 0 to the value set in C1-14 (Accel/Decel Rate Frequency)
- Decel Times 1 through 4 and the Fast-stop Time determine the time required to decelerate from the value set in C1-14 (Accel/Decel Rate Frequency ) to 0 Hz.

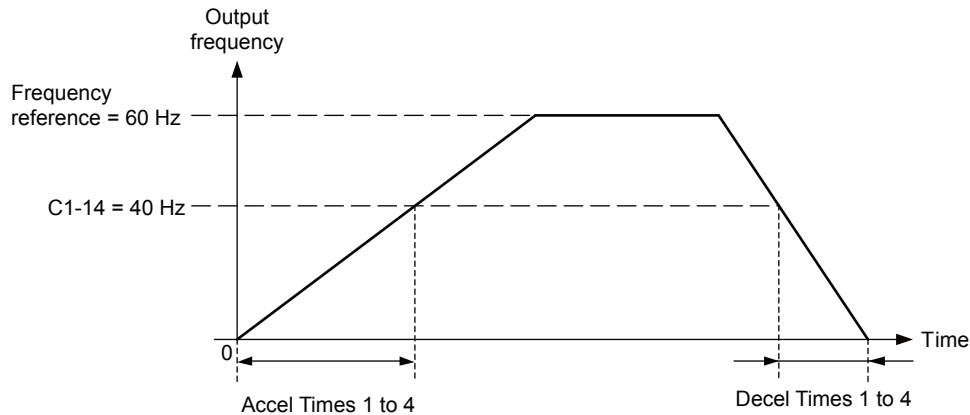


Figure 5.25 Accel/Decel Rate, Example 2 (C1-14 = 40 Hz, E1-04 = 60 Hz, Frequency Reference = 60 Hz)

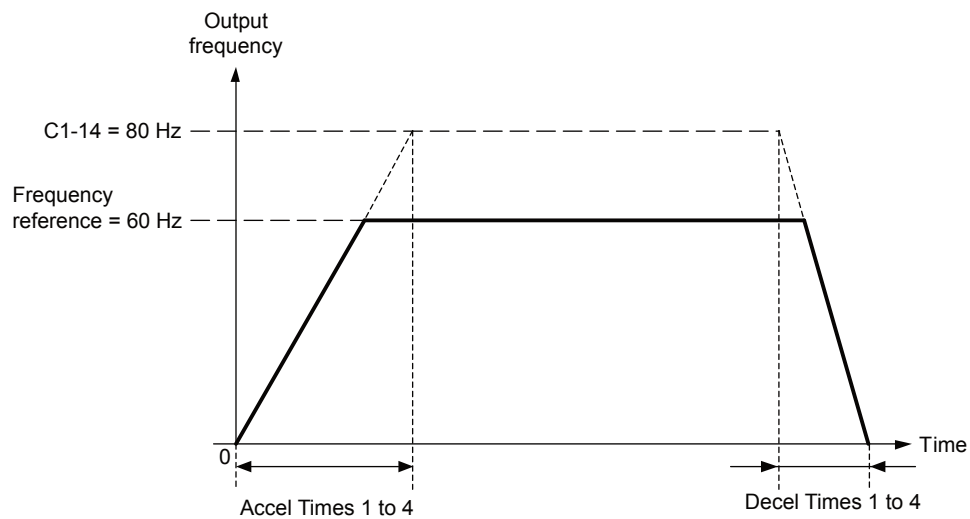


Figure 5.26 Accel/Decel Rate, Example 3 (C1-14 = 80 Hz, E1-04 = 60 Hz, Frequency Reference = 60 Hz)

- Note:**
1. The accel/decel times shown in [Figure 5.24](#) to [Figure 5.26](#) assume S-curve characteristic time during accel/decel at start and accel/decel at stop of 0.00 s (parameters C2-01 to C2-04).
  2. When Stall Prevention during acceleration is enabled (L3-01  $\neq$  0), the accel time may take longer than the set value.
  3. When Stall Prevention during deceleration is enabled (L3-04  $\neq$  0), the decel time may take longer than the set value.

### ◆ C2: S-Curve Characteristics

Use S-curve characteristics to smooth acceleration and deceleration and to minimize abrupt shock to the load. Set S-curve characteristic time during acceleration/deceleration at start and acceleration/deceleration at stop. If a STo fault (Step Out Detection) occurs when starting a PM motor, try increasing the value set to C2-01.

## ■ C2-01 to C2-04: S-Curve Characteristics

C2-01 through C2-04 set separate S-curves for each section of the acceleration or deceleration.

| No.   | Parameter Name                        | Setting Range   | Default |
|-------|---------------------------------------|-----------------|---------|
| C2-01 | S-Curve Characteristic at Accel Start | 0.00 to 10.00 s | 0.20 s  |
| C2-02 | S-Curve Characteristic at Accel End   |                 | 0.20 s  |
| C2-03 | S-Curve Characteristic at Decel Start |                 | 0.20 s  |
| C2-04 | S-Curve Characteristic at Decel End   |                 | 0.00 s  |

Figure 5.27 explains how S-curves are applied.

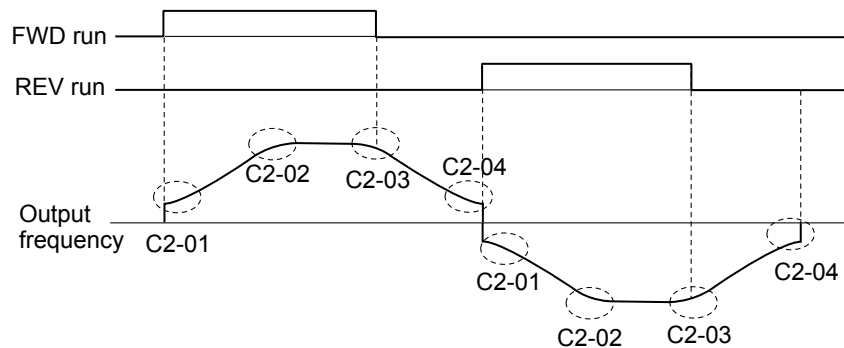


Figure 5.27 S-Curve Timing Diagram - FWD/REV Operation

Setting the S-curve will increase the acceleration and deceleration times.

Actual accel time = accel time setting + (C2-01 + C2-02)/2

Actual decel time = decel time setting + (C2-03 + C2-04)/2

## ◆ C3: Slip Compensation

The Slip Compensation function prevents motor speed loss due to an increase in load.

**Note:** Before making changes to the Slip Compensation parameters, make sure the motor parameters and V/f pattern are set properly or perform Auto-Tuning.

### ■ C3-01: Slip Compensation Gain

This parameter sets the gain for the motor slip compensation function. Although this parameter rarely needs to be changed, adjustments might be needed under the following situations:

- If the speed at constant frequency reference is lower than the frequency reference, increase C3-01.
- If the speed at constant frequency reference is higher than the frequency reference, decrease C3-01.

| No.   | Parameter Name         | Setting Range | Default |
|-------|------------------------|---------------|---------|
| C3-01 | Slip Compensation Gain | 0.0 to 2.5    | 0.0     |

### ■ C3-02: Slip Compensation Primary Delay Time

Adjusts the filter on the output of the slip compensation function. Although this parameter rarely needs to be changed, adjustments might be needed under the following situations:

- Decrease the setting when the slip compensation response is too slow.
- Increase this setting when the speed is not stable.

| No.   | Parameter Name                       | Setting Range | Default |
|-------|--------------------------------------|---------------|---------|
| C3-02 | Slip Compensation Primary Delay Time | 0 to 10000 ms | 2000 ms |

### ■ C3-03: Slip Compensation Limit

Sets the upper limit for the slip compensation function as a percentage of the motor rated slip (E2-02).

### 5.3 C: Tuning

| No.   | Parameter Name          | Setting Range | Default |
|-------|-------------------------|---------------|---------|
| C3-03 | Slip Compensation Limit | 0 to 250%     | 200%    |

The slip compensation limit is constant throughout the constant torque range. In the constant power range it is increased based on C3-03 and the output frequency as shown in the following diagram.

**Note:** This parameter is disabled when using V/f Control with Simple PG Feedback Control (H6-01 = 3).

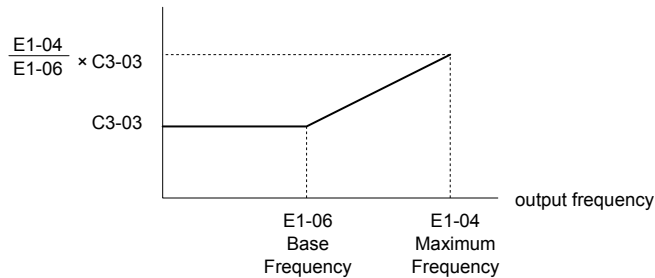


Figure 5.28 Slip Compensation Limit

#### ■ C3-04: Slip Compensation Selection during Regeneration

When the slip compensation during regeneration function has been activated and regenerative load is applied, it might be necessary to use a braking option (braking resistor, braking resistor unit, or braking unit).

Even if enabled, this function does not operate when the output frequency is too low.

| No.   | Parameter Name                                  | Setting Range | Default |
|-------|---|---------------|---------|
| C3-04 | Slip Compensation Selection during Regeneration | 0 or 1        | 0       |

##### Setting 0: Disabled

Slip compensation is not provided. Depending on the load and operation mode (motoring or regenerative) the actual motor speed will be lower or higher than the frequency reference.

##### Setting 1: Enabled

Slip compensation is enabled during regenerative operation. It will not be active at output frequencies below 6 Hz.

### ◆ C4: Torque Compensation

The torque compensation function compensates for insufficient torque production at start-up or when a load is applied.

**Note:** Before making changes to the torque compensation parameters make sure the motor parameters and V/f pattern are set properly or perform Auto-Tuning.

#### ■ C4-01: Torque Compensation Gain

Sets the gain for the torque compensation function.

| No.   | Parameter Name           | Setting Range | Default |
|-------|--------------------------|---------------|---------|
| C4-01 | Torque Compensation Gain | 0.00 to 2.50  | 1.00    |

##### Torque Compensation in V/f

The drive calculates the motor primary voltage loss using the output current and the termination resistor value and adjusts the output voltage to compensate insufficient torque at start or when load is applied. The effects of this voltage compensation can be increased or decreased using parameter C4-01.

##### Adjustment

Although this parameter rarely needs to be changed, it may be necessary to adjust the torque compensation gain in small steps of 0.05 in the following situations:

- Increase this setting when using a long motor cable.
- Decrease this setting when motor oscillation occurs.

Adjust C4-01 so the output current does not exceed the drive rated current.

#### ■ C4-02: Torque Compensation Primary Delay Time 1

Sets the delay time used for applying torque compensation.



| No.   | Parameter Name                           | Setting Range | Default |
|-------|--|---------------|---------|
| C4-02 | Torque Compensation Primary Delay Time 1 | 0 to 60000 ms | 200 ms  |

### Adjustment

Although C4-02 rarely needs to be changed, adjustments may be necessary in the following situations:

- Increase this setting if the motor vibrates.
- Decrease this setting if the motor responds too slowly to changes in the load.

## ◆ C6: Carrier Frequency

### ■ C6-02: Carrier Frequency Selection

Parameter C6-02 sets the switching frequency of the drive's output transistors. It can be changed in order to reduce audible noise and also reduce leakage current.

**Note:** The drive rated current is reduced when the carrier frequency is set higher than the default value.

| No.   | Parameter Name              | Setting Range | Default |
|-------|-----------------------------|---------------|---------|
| C6-02 | Carrier Frequency Selection | 1 to B; F     | 7       |

### Settings:

| C6-02 | Carrier Frequency | C6-02 | Carrier Frequency             |
|-------|-------------------|-------|-------------------------------|
| 1     | 2.0 kHz           | 8     | Swing PWM 2                   |
| 2     | 5.0 kHz           | 9     | Swing PWM 3                   |
| 3     | 8.0 kHz           | A     | Swing PWM 4                   |
| 4     | 10.0 kHz          | B </> | Leakage Current Rejection PWM |
| 5     | 12.5 kHz          | F     | User-defined (C6-03 to C6-05) |
| 6     | 15.0 kHz          |       |                               |
| 7     | Swing PWM 1       |       |                               |

<1> Setting B uses a PWM pattern that reduces the amount of leakage current detected over long wiring distances. This can help reduce alarm detection and problems with the current monitor that result from leakage current over long wiring distances. This is the same as setting the carrier frequency to 2 kHz.

**Note:** Swing PWM uses 2.0 kHz carrier frequency as a base. Applying special PWM patterns minimizes the audible noise of the motor.

### Guidelines for Carrier Frequency Parameter Setup

| Symptom   | Remedy   |
|---|--|
| Speed and torque are unstable at low speeds.          | Lower the carrier frequency.   |
| Noise from the drive is affecting peripheral devices. |  |
| Excessive leakage current from the drive.             |  |
| Wiring between the drive and motor is too long. </>   | <ul style="list-style-type: none"> <li>• Lower the carrier frequency</li> <li>• Set C6-02 to B if an alarm is detected or if leakage current causes a problem with the current monitor.</li> </ul> |
| Audible motor noise is too loud.                      | Increase the carrier frequency or use Swing PWM. </>   |

<1> The carrier frequency may need to be lowered if the motor cable is too long. Refer to the table below.

<2> Default setting is 7 (Swing PWM), equivalent to setting 2 kHz. Increasing the carrier frequency is fine, but remember that the drive rated current falls when the carrier frequency is increased.

## 5.3 C: Tuning

### ■ C6-03/C6-04/C6-05: Carrier Frequency Upper Limit/Lower Limit/Proportional Gain

Use these parameters to set a user defined or a variable carrier frequency. To set the upper and lower limits, first set C6-02 to “F”.

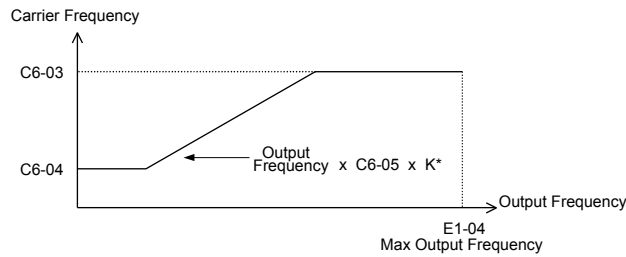
| No.   | Parameter Name                      | Setting Range   | Default |
|-------|-------------------------------------|-----------------|---------|
| C6-03 | Carrier Frequency Upper Limit       | 1.0 to 15.0 kHz | 2.0 kHz |
| C6-04 | Carrier Frequency Lower Limit       | 1.0 to 15.0 kHz | 2.0 kHz |
| C6-05 | Carrier Frequency Proportional Gain | 0 to 99         | 0       |

#### Setting a Fixed User Defined Carrier Frequency

A carrier frequency between the fixed selectable values can be entered in parameter C6-03 when C6-02 is set to “F”. In V/f Control, parameter C6-04 must also be adjusted to the same value as C6-03.

#### Setting a Variable Carrier Frequency

In V/f Control, the carrier frequency can be set up to change linearly with the output frequency. In this case the upper and lower limits for the carrier frequency and the carrier frequency proportional gain (C6-03, C6-04, C6-05) have to be set as shown in [Figure 5.29](#).



**Figure 5.29 Carrier Frequency Changes Relative to Output Frequency**

K is a coefficient determined by the value of C6-03:

- 10.0 kHz > C6-03 ≥ to 5.0 kHz: K = 2
- 5.0 kHz > C6-03: K = 1
- C6-03 ≥ 10.0 kHz: K = 3

- Note:**
1. A carrier frequency error (oPE11) will occur when the carrier frequency proportional gain is greater than 6 while C6-03 is less than C6-04.
  2. When C6-05 is set lower than 7, C6-04 is disabled and the carrier frequency will be fixed to the value set in C6-03.

## 5.4 d: Reference Settings

### ◆ d1: Frequency Reference

#### ■ d1-01 to d1-17: Frequency Reference 1 to 16 and Jog Reference

Up to 17 preset references (including Jog reference) can be programmed in the drive. The references can be switched during Run by digital inputs. The acceleration/deceleration to the new reference is performed using the active acceleration/deceleration time.

The Jog frequency must be selected by a separate digital input and has priority over the references 1 to 16.

The multi-speed references 1 and 2 can be provided by analog inputs.

| No.            | Parameter Name              | Setting Range         | Default |
|----------------|-----------------------------|-----------------------|---------|
| d1-01 to d1-16 | Frequency Reference 1 to 16 | 0.00 to 400.00 Hz <1> | 0.00 Hz |
| d1-17          | Jog Frequency Reference     | 0.00 to 400.00 Hz <1> | 6.00 Hz |

<1> The upper limit is determined by the maximum output frequency (E1-04) and upper limit for the frequency reference (d2-01).

#### Multi-Step Speed Selection

Depending on how many speeds are used, some digital inputs have to be programmed for Multi-Step Speed Reference 1, 2, 3 and 4 (H1-□□ = 3, 4, 5, 32). For the Jog reference a digital input must be set to H1-□□ = 6.

Notes on using analog inputs as multi-speed 1 and 2:

- If the frequency reference source is assigned to analog input A1 (b1-01 = 1), then this input will be used for Frequency Reference 1 instead of d1-01. If the reference source is assigned to the digital operator (b1-01 = 0), then d1-01 will be used as Frequency Reference 1.
- When the analog input A2 function is set to “Auxiliary Frequency” (H3-10 = 2), then the value input to terminal A2 will be used as the Frequency Reference 2 instead of the value set to parameter d1-02. When H3-10 does not equal 2, then d1-02 becomes the reference for Frequency Reference 2.

The different speed references can be selected as shown in [Table 5.10](#). [Figure 5.30](#) illustrates the multi-step speed selection.

**Table 5.10 Multi-Step Speed Reference and Terminal Switch Combinations**

| Reference                           | Multi-Step Speed 1<br>H1-□□=3 | Multi-Step Speed 2<br>H1-□□=4 | Multi-Step Speed 3<br>H1-□□=5 | Multi-Step Speed 4<br>H1-□□=32 | Jog Reference<br>H1-□□=6 |
|-------------------------------------|-------------------------------|-------------------------------|-------------------------------|--------------------------------|--------------------------|
| Frequency Reference 1 (d1-01/A1)    | OFF                           | OFF                           | OFF                           | OFF                            | OFF                      |
| Frequency Reference 2 (d1-02/A2)    | ON                            | OFF                           | OFF                           | OFF                            | OFF                      |
| Frequency Reference 3 (d1-03)       | OFF                           | ON                            | OFF                           | OFF                            | OFF                      |
| Frequency Reference 4 (d1-04)       | ON                            | ON                            | OFF                           | OFF                            | OFF                      |
| Frequency Reference 5 (d1-05)       | OFF                           | OFF                           | ON                            | OFF                            | OFF                      |
| Frequency Reference 6 (d1-06)       | ON                            | OFF                           | ON                            | OFF                            | OFF                      |
| Frequency Reference 7 (d1-07)       | OFF                           | ON                            | ON                            | OFF                            | OFF                      |
| Frequency Reference 8 (d1-08)       | ON                            | ON                            | ON                            | OFF                            | OFF                      |
| Frequency Reference 9 (d1-09)       | OFF                           | OFF                           | OFF                           | ON                             | OFF                      |
| Frequency Reference 10 (d1-10)      | ON                            | OFF                           | OFF                           | ON                             | OFF                      |
| Frequency Reference 11 (d1-11)      | OFF                           | ON                            | OFF                           | ON                             | OFF                      |
| Frequency Reference 12 (d1-12)      | ON                            | ON                            | OFF                           | ON                             | OFF                      |
| Frequency Reference 13 (d1-13)      | OFF                           | OFF                           | ON                            | ON                             | OFF                      |
| Frequency Reference 14 (d1-14)      | ON                            | OFF                           | ON                            | ON                             | OFF                      |
| Frequency Reference 15 (d1-15)      | OFF                           | ON                            | ON                            | ON                             | OFF                      |
| Frequency Reference 16 (d1-16)      | ON                            | ON                            | ON                            | ON                             | OFF                      |
| Jog Frequency Reference (d1-17) <1> | –                             | –                             | –                             | –                              | ON                       |

<1> The Jog frequency overrides the frequency reference being used.

## 5.4 d: Reference Settings

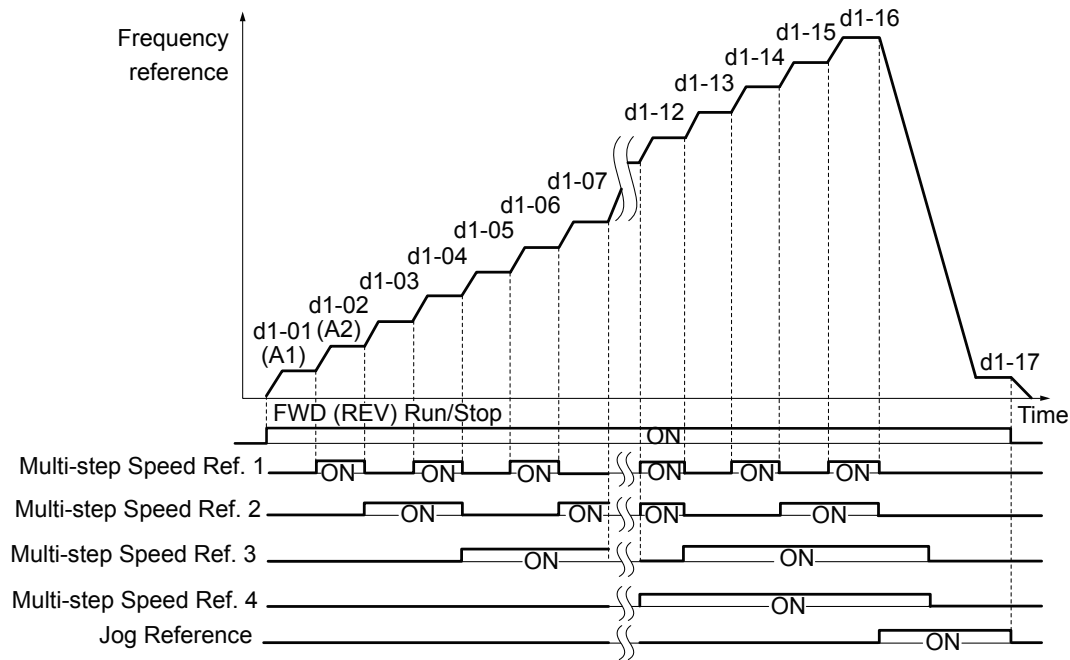


Figure 5.30 Preset Reference Timing Diagram

### ◆ d2: Frequency Upper/Lower Limits

By entering upper or lower frequency limits, the drive programmer can prevent operation of the drive above or below levels that may cause resonance and or equipment damage.

#### ■ d2-01: Frequency Reference Upper Limit

Sets the maximum frequency reference as a percentage of the maximum output frequency. This limit applies to all frequency references.

Even if the frequency reference is set to a higher value, the drive internal frequency reference will not exceed this value.

| No.   | Parameter Name                  | Setting Range | Default |
|-------|---------------------------------|---------------|---------|
| d2-01 | Frequency Reference Upper Limit | 0.0 to 110.0% | 100.0%  |

#### ■ d2-02: Frequency Reference Lower Limit

Sets the minimum frequency reference as a percentage of the maximum output frequency. This limit applies to all frequency references.

If a lower reference than this value is input, the drive will run at the d2-02 level. If the drive is started with a lower reference than d2-02, it will accelerate up to d2-02.

| No.   | Parameter Name                  | Setting Range | Default |
|-------|---------------------------------|---------------|---------|
| d2-02 | Frequency Reference Lower Limit | 0.0 to 110.0% | 0.0%    |

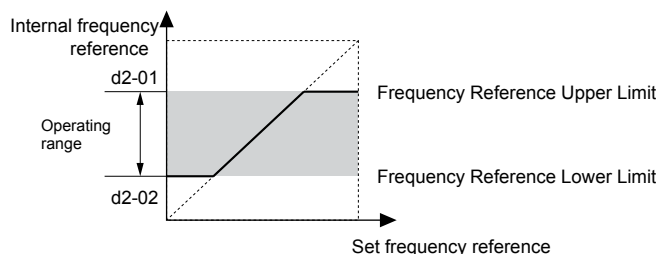


Figure 5.31 Frequency Reference: Upper and Lower Limits

### ■ d2-03: Master Speed Reference Lower Limit

Unlike frequency reference lower limit (d2-02) which will affect the frequency reference no matter where it is sourced from (i.e., analog input, preset speed, Jog speed, etc.), the master speed lower limit (d2-03) sets a lower limit that will only affect the analog input (terminals A1 and A2) that is the active master speed frequency.

Set as a percentage of the maximum output frequency.

**Note:** The lower limits for the Jog frequency, multi-step speed settings, and 2-step speed settings do not change. When lower limits are set to both the frequency reference (d2-02) and the main frequency reference (d2-03), the drive uses the greater of those two values as the lower limit.

| No.   | Parameter Name                     | Setting Range | Default |
|-------|------------------------------------|---------------|---------|
| d2-03 | Master Speed Reference Lower Limit | 0.0 to 110.0% | 0.0%    |

### ■ E2-01: Motor Rated Current

Provides motor control, protects the motor, and calculates torque limits. Set E2-01 to the full load amps (FLA) stamped on the motor nameplate. If Auto-Tuning completes successfully, the value entered to T1-04 will automatically be saved to E2-01.

| No.   | Parameter Name      | Setting Range   | Default             |
|-------|---------------------|---|---------------------|
| E2-01 | Motor Rated Current | 10% to 200% of the drive rated current <sup>&lt;/&gt;</sup> | Determined by o2-04 |

<1> Display is in the following units:

BV0006 to BV0018, 2V0006 to 2V0040, and 4V0002 to 4V0023: 0.01 A units.

2V0056 to 2V0069 and 4V0031 to 4V0038: 0.1 A units.

**Note:** An oPE02 error will occur if the motor rated current in E2-01 is set lower than the motor no-load current in E2-03. Set E2-03 correctly to prevent this error.

## ◆ d3: Jump Frequency

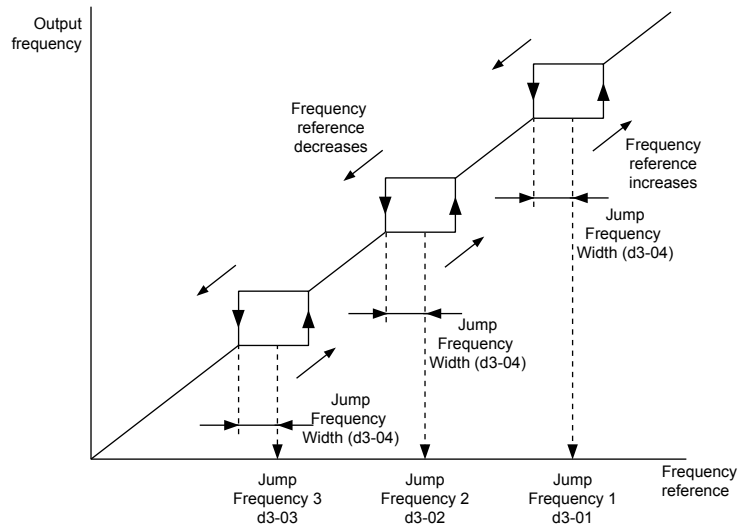
### ■ d3-01 to d3-04: Jump Frequencies 1, 2, 3, and Jump Frequency Width

In order to avoid continuous operation at a speed that causes resonance in driven machinery, the drive can be programmed with three separate Jump frequencies that will not allow continued operation within specific frequency ranges. If the speed reference falls within a Jump frequency dead band, the drive will clamp the frequency reference just below the dead band and only accelerate past it when the frequency reference rises above the upper end of the dead band.

Setting parameters d3-01 through d3-03 to 0.0 Hz disables the Jump frequency function.

| No.   | Parameter Name       | Setting Range   | Default |
|-------|----------------------|-----------------|---------|
| d3-01 | Jump Frequency 1     | 0.0 to 400.0 Hz | 0.0 Hz  |
| d3-02 | Jump Frequency 2     | 0.0 to 400.0 Hz | 0.0 Hz  |
| d3-03 | Jump Frequency 3     | 0.0 to 400.0 Hz | 0.0 Hz  |
| d3-04 | Jump Frequency Width | 0.0 to 20.0 Hz  | 1.0 Hz  |

Figure 5.32 shows the relationship between the Jump frequency and the output frequency.



**Figure 5.32 Jump Frequency Operation**

- Note:**
1. The drive will use the active accel/decel time to pass through the specified dead band range but will not allow continuous operation in that range.
  2. When using more than one Jump frequency, make sure that  $d3-01 \geq d3-02 \geq d3-03$ .

### ◆ d4: Frequency Hold and Up/Down 2 Function

#### ■ d4-01: Frequency Reference Hold Function Selection

This parameter is effective when either of the digital input functions listed below is used.

- Accel/decel ramp hold function (H1-□□ = A)
- Up/Down function (H1-□□ = 10 and 11, sets the frequency reference by digital inputs)
- Up/Down 2 function (H1-□□ = 75/76, adds a bias to the frequency reference using digital inputs)

Parameter d4-01 determines whether the frequency reference or the frequency bias (Up/Down 2) value is saved when the Run command is cleared or the power supply is shut down.

| No.   | Parameter Name                              | Setting Range | Default |
|-------|---|---------------|---------|
| d4-01 | Frequency Reference Hold Function Selection | 0 or 1        | 0       |

The operation depends on with what function parameter d4-01 is used.

#### Setting 0: Disabled

- Acceleration Hold

The hold value will be reset to 0 Hz when the Run command is canceled or the drive power is switched off. The active frequency reference will be the value the drive uses when it restarts.

- Up/Down

The frequency reference value will be reset to 0 Hz when the Run command is canceled or the drive power is switched off. The drive will start from 0 Hz when restarted.

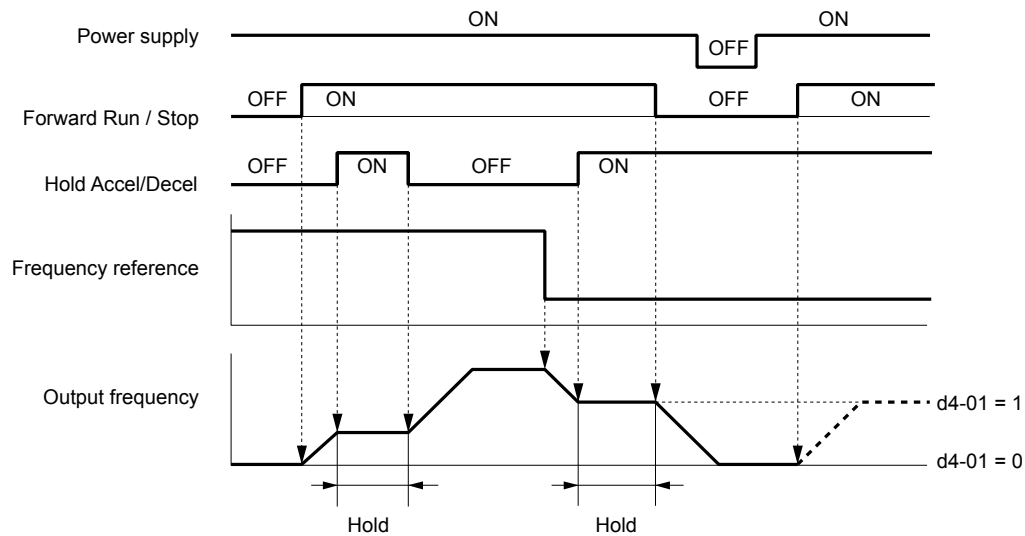
- Up/Down 2

The frequency bias is not saved when the Run command is switched off or 5 s after the Up/Down 2 command has been released. The Up/Down 2 function will start with a bias of 0% when the drive is restarted.

#### Setting 1: Enabled

- Acceleration Hold

The last hold value will be saved when the Run command or the drive power is switched off. The drive will use the value that was saved as the frequency reference when it restarts. The accel/decel hold input must be enabled the entire time or else the hold value will be cleared.



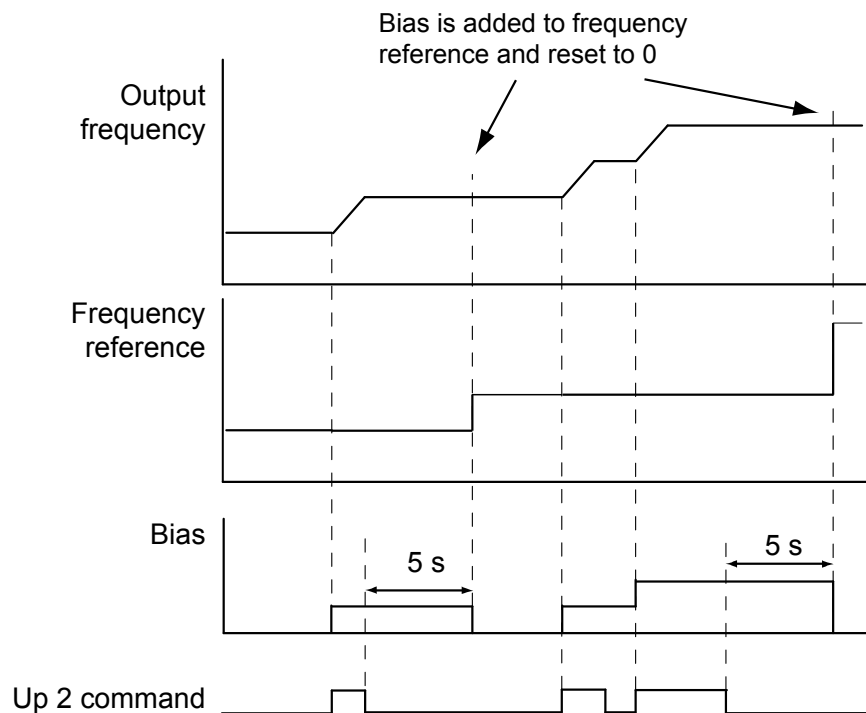
**Figure 5.33** Frequency Reference Hold with Accel/Decel Hold Function

- Up/Down

The frequency reference value will be saved when the Run command or the drive power is switched off. The drive will use the frequency reference that was saved when it restarts.

- Up/Down 2 with Frequency Reference from Digital Operator

When the digital operator is selected as the frequency reference source, the bias will be added to the frequency reference that was selected 5 s after the Up/Down 2 command has been released, and then reset to 0 afterwards. The new frequency reference value is then saved. When the Run command or the power supply is switched off, the drive will use the value that was when it restarts.



**Figure 5.34** Up/Down 2 Example with Reference from Digital Operator and d4-01 = 1

- Up/Down 2 with Frequency Reference from Other Input Sources

When the frequency reference is set by an another source than the digital operator, the bias value will be saved in parameter d4-06 exactly 5 s after the Up/Down 2 command has been released. When the Run command is turned off or the power is switched off, the drive will use the value saved in d4-06 when it restarts.

## 5.4 d: Reference Settings

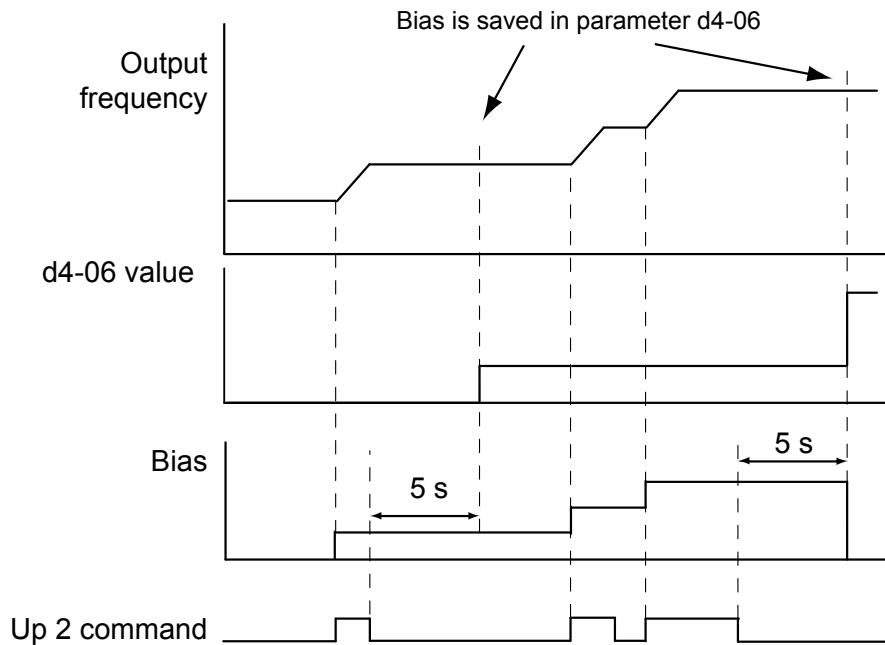


Figure 5.35 Up/Down 2 Example with Other Reference than Digital Operator and d4-01 = 1

**Note:** Make sure to set the Up/Down 2 limits properly when using d4-01 = 1 in combination with the Up/Down 2 function. *Refer to d4-08: Frequency Reference Bias Upper Limit (Up/Down 2) on page 154 and Refer to d4-09: Frequency Reference Bias Lower Limit (Up/Down 2) on page 154* for details on the limit settings.

### Clearing the Value that was Saved

Depending on which function is used, the frequency reference value that was saved can be cleared by:

- Releasing the acceleration hold input.
- Setting an Up or Down command while no Run command is active.

### ■ d4-03: Frequency Reference Bias Step (Up/Down 2)

Sets the bias that is added to or subtracted from the frequency reference by the Up/Down 2 function.

| No.   | Parameter Name                | Setting Range    | Default |
|-------|-------------------------------|------------------|---------|
| d4-03 | Frequency Reference Bias Step | 0.00 to 99.99 Hz | 0.00 Hz |

The operation depends on the set value:

#### Setting d4-03 = 0.0 Hz

While the Up 2 or Down 2 command is enabled, the bias value is increased or decreased using the accel/decel time determined by parameter d4-04.

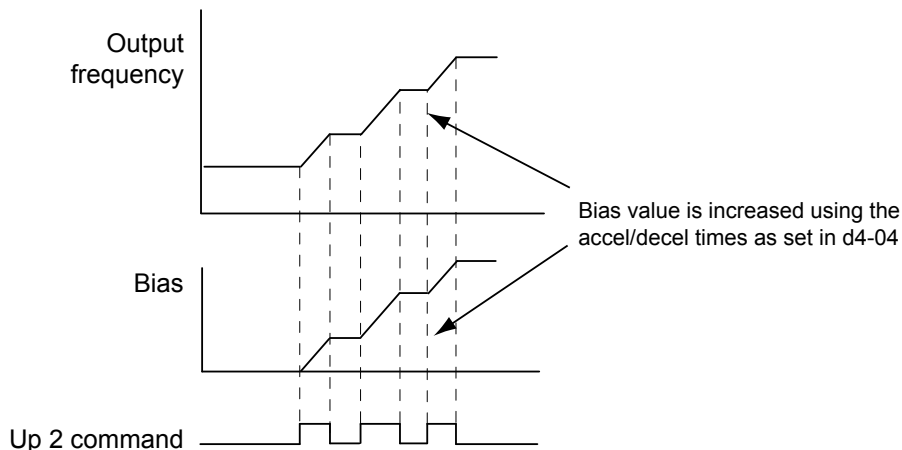


Figure 5.36 Up/Down 2 Bias when d4-03 = 0.0 Hz



**Setting d4-03 > 0.0 Hz**

When an Up 2 or Down 2 command is enabled, the bias is increased or decreased in steps for the value set in d4-03. The frequency reference changes with the accel/decel times determined by parameter d4-04.

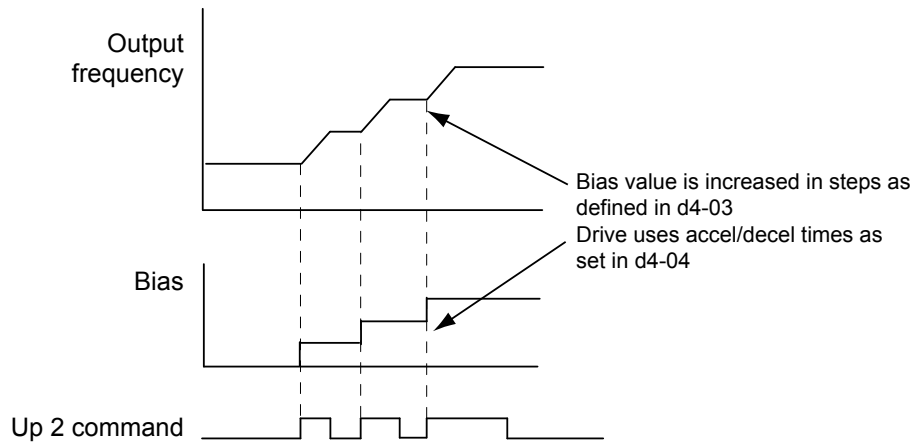


Figure 5.37 Up/Down 2 Bias when d4-03 > 0.0 Hz

**■ d4-05: Frequency Reference Bias Operation Mode Selection (Up/Down 2)**

Determines if the bias value is held or not when the Up/Down 2 inputs are both released or both enabled. The parameter is effective only when parameter d4-03 is set to 0.00.

| No.   | Parameter Name                                    | Setting Range | Default |
|-------|---|---------------|---------|
| d4-05 | Frequency Reference Bias Operation Mode Selection | 0 or 1        | 0       |

**Setting 0: Hold Bias Value**

The bias value will be held if no input Up 2 or Down 2 is active.

**Setting 1: Reset Bias Value**

The bias is reset to 0% when both inputs Up 2 and Down 2 are either on or off. The drive will use the accel/decel time as selected in d4-04 to accelerate or decelerate to the frequency reference value.

**■ d4-06: Frequency Reference Bias (Up/Down 2)**

This parameter is used to save the frequency reference bias value set by the Up/Down 2 function. It is set as a percentage of the maximum output frequency. The function of d4-06 depends on how the Up/Down 2 function is configured.

- This parameter is not normally used when the frequency reference is set by the digital operator. The user can set d4-06 to a certain value that will be applied when the operation is started, but it will be reset when the frequency reference changes (including multi-step references) or will be disabled when d4-01 = 0 and the Run command is removed.
- When d4-01 = 0 and the frequency reference is set by an analog or pulse input, the value set in d4-06 is generally added to or subtracted from the frequency reference.
- When d4-01 = 1 and the frequency reference is set by a different source than the digital operator, the bias value adjusted with the Up/Down 2 inputs is stored in d4-06 when 5 s have passed after the Up 2 or Down 2 command release.

| No.   | Parameter Name           | Setting Range   | Default |
|-------|--------------------------|-----------------|---------|
| d4-06 | Frequency Reference Bias | -99.9 to 100.0% | 0.0%    |

**Conditions that Generally Reset or Disable Parameter d4-06**

- When the Up/Down 2 function has not been assigned to the multi-function terminals
- When the frequency reference source has been changed (including LOCAL/REMOTE or external reference 1/external reference 2 switch over by digital inputs)
- If d4-03 = 0 Hz, d4-05 = 1 and the Up/Down 2 commands are both open or both closed
- Any changes to the maximum frequency set to E1-04

## 5.4 d: Reference Settings

### ■ d4-07: Analog Frequency Reference Fluctuation Limit (Up/Down 2)

This parameter is for handling changes in the frequency reference while the terminal set for Up 2 or Down 2 is enabled. If the frequency reference changes for more than the level set to d4-07, then the bias value will be held, and the drive will accelerate or decelerate following the frequency reference. When the frequency reference is reached, the bias hold is released and the bias follows the Up/Down 2 input commands.

Parameter d4-07 is applicable only if the frequency reference is set by an analog or pulse input.

| No.   | Parameter Name                               | Setting Range | Default |
|-------|--|---------------|---------|
| d4-07 | Analog Frequency Reference Fluctuation Limit | 0.1 to 100.0% | 1.0%    |

### ■ d4-08: Frequency Reference Bias Upper Limit (Up/Down 2)

Parameter d4-08 sets the upper limit of the Up/Down 2 bias (monitor U6-20) and the value that can be saved in parameter d4-06. Set this parameter to an appropriate value before using the Up/Down 2 function.

**Note:** When the frequency reference is set by the digital operator (b1-01 = 0) and d4-01 = 1, the bias value will be added to the frequency reference if no Up/Down 2 command is received for 5 s, and will be reset to 0 afterwards. From that point the bias can be increased up to the limit set in d4-08 again.

| No.   | Parameter Name                       | Setting Range | Default |
|-------|--------------------------------------|---------------|---------|
| d4-08 | Frequency Reference Bias Upper Limit | 0.0 to 100.0% | 100.0%  |

### ■ d4-09: Frequency Reference Bias Lower Limit (Up/Down 2)

Parameter d4-09 sets the lower limit of the Up/Down 2 bias (monitor U6-20) and the value that can be saved in parameter d4-06. Set this parameter to an appropriate value before using the Up/Down 2 function.

**Note:** When the frequency reference is set by the digital operator (b1-01 = 0) and d4-01 = 1, the bias value will be added to the frequency reference if no Up/Down 2 command is received for 5 s, and will be reset to 0 afterwards. If the bias is increased using the Up 2 command, once it is added to the frequency reference the speed cannot be reduced with a Down 2 command if the limit set in d4-09 is 0. In this case make sure to set a negative lower limit in d4-09 to allow speed reduction.

| No.   | Parameter Name                       | Setting Range | Default |
|-------|--------------------------------------|---------------|---------|
| d4-09 | Frequency Reference Bias Lower Limit | -99.9 to 0.0% | 0.0%    |

### ■ d4-10: Up/Down Frequency Reference Limit Selection

Selects how the lower frequency limit is set when the Up/Down function is used. [Refer to Settings 10 and 11: Up/Down Function on page 165](#) for details on the Up/Down function in combination with frequency reference limits.

#### Setting 0: Lower Limit is Determined by d2-02 or Analog Input

The lower frequency reference limit is determined by the higher value of both, parameter d2-02 or an analog input that is programmed for “Frequency Bias” (H3-02/10 = 0).

**Note:** If the external reference change over function (H1-□□ = 2) used to switch between Up/Down function and analog input as reference source, the analog value would become the lower reference limit when the Up/Down reference is active. Change d4-10 to 1 to make the Up/Down function independent of the analog input value.

#### Setting 1: Lower Limit is Determined by Parameter d2-02

Only parameter d2-02 sets the lower frequency reference limit.

## 5.5 E: Motor Parameters

E parameters cover V/f pattern and motor data settings.

### ◆ E1: V/f Characteristics

#### ■ E1-01: Input Voltage Setting

Set the input voltage parameter to the nominal voltage of the AC power supply. This parameter adjusts the levels of some protective features of the drive (overvoltage, Stall Prevention, etc.).

**NOTICE:** Set parameter E1-01 to match the input voltage of the drive. Drive input voltage (not motor voltage) must be set in E1-01 for the protective features of the drive to function properly. Failure to comply could result in improper drive operation.

| No.       | Parameter Name        | Setting Range | Default |
|-----------|-----------------------|---------------|---------|
| E1-01 </> | Input Voltage Setting | 155 to 255 V  | 230 V   |

<1> The setting range and default value shown here are for 200 V class drives. Double this for 400 V class units.

#### E1-01 Related Values

The input voltage setting determines the over-/undervoltage detection level and the operation levels of the braking transistor as well as the KEB function and the overvoltage suppression function.

| Voltage     | Setting Value of E1-01 | (Approximate Values) |                     |                                 |   |   |
|-------------|------------------------|----------------------|---------------------|---------------------------------|---|---|
|             |                        | ov Detection Level   | BTR Operation Level | Uv Detection Level (L2-05)      | Desired DC Bus Voltage during KEB (L2-11) | ov Suppression / Stall Prevention Level (L3-17) |
| 200 V Class | all settings           | 410 V                | 394 V               | 190 V<br>(single-phase = 160 V) | 240 V                                     | 370 V   |
| 400 V Class | setting ≥ 400 V        | 820 V                | 788 V               | 380 V                           | 480 V                                     | 740 V   |
|             | setting < 400 V        | 740 V                | 708 V               | 350 V                           | 440 V                                     | 660 V   |

**Note:** The braking transistor operation levels are valid for the drive internal braking transistor. If an external CDBR braking chopper is used, refer to the instruction manual of that unit.

#### ■ V/f Pattern Settings

The drive utilizes a set V/f pattern to determine the appropriate output voltage level for each relative to the frequency reference. There are 15 different preset V/f patterns to select from with varying voltage profiles, saturation levels (frequency at which maximum voltage is reached), and maximum frequencies. Additionally, one custom V/f pattern can be set up by programming parameters E1-04 through E1-10.

#### V/f Pattern Setup for V/f Control

1. Set the input voltage for the drive. [Refer to E1-01: Input Voltage Setting on page 155.](#)
2. Set the V/f pattern by:
  - a) choosing one of the 15 preset V/f patterns (E1-03 = 0 to E).
  - b) select the custom V/f pattern (E1-03 = F, default setting).
3. When using one of the 15 presets, E1-04 through E1-13 are automatically set. Refer to the description below. For a custom V/f pattern, E1-04 through E1-13 must be adjusted manually. [Refer to V/f Pattern Settings E1-04 to E1-13 on page 158.](#)

#### ■ E1-03: V/f Pattern Selection

This parameter can only be changed when the drive is operating in V/f Control. It allows the user to select the V/f pattern from 15 predefined patterns or to create a custom V/f pattern.

| No.   | Parameter Name        | Setting Range | Default |
|-------|-----------------------|---------------|---------|
| E1-03 | V/f Pattern Selection | 0 to F        | F       |

## 5.5 E: Motor Parameters

### Setting the V/f Pattern

Choose the V/f pattern that meets the application demands from the table below. Set the correct value to E1-03. The V/f parameters E1-04 to E1-13 can only be monitored, not changed.

- Note:**
1. Setting an improper V/f pattern may result in low motor torque or increased current due to overexcitation.
  2. Parameter E1-03 is not reset when the drive is initialized.

**Table 5.11 Predefined V/f Patterns**

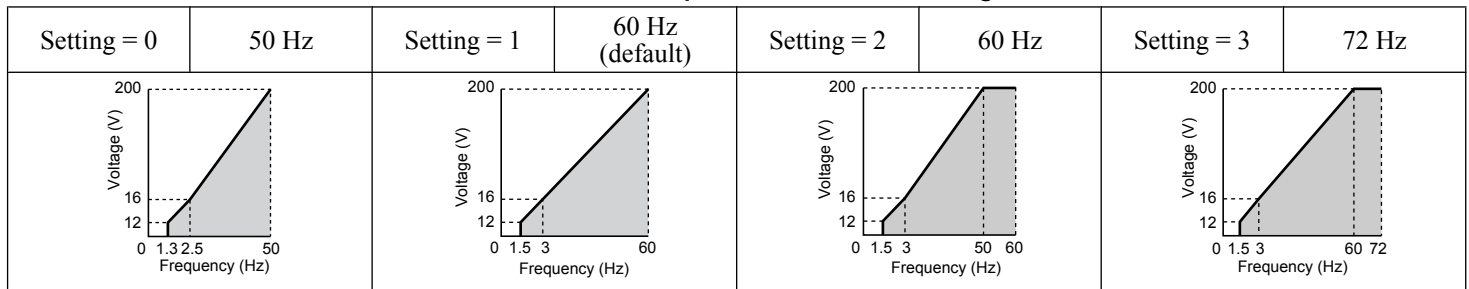
| Setting | Specification               | Characteristic       | Application   |
|---------|-----------------------------|----------------------|---|
| 0       | 50 Hz                       | Constant torque      | For general purpose applications. Torque remains constant regardless of changes to speed.   |
| 1       | 60 Hz<br>(default setting)  |                      |   |
| 2       | 60 Hz (with 50 Hz base)     |                      |   |
| 3       | 72 Hz (with 60 Hz base)     |                      |   |
| 4       | 50 Hz, Heavy Duty 2         | Derated torque       | For fans, pumps, and other applications that require torque derating relative to the load.  |
| 5       | 50 Hz, Heavy Duty 1         |                      |   |
| 6       | 60 Hz, Heavy Duty 1         |                      |   |
| 7       | 60 Hz, Heavy Duty 2         |                      |   |
| 8       | 50 Hz, mid starting torque  | High starting torque | Select high starting torque when: <ul style="list-style-type: none"> <li>• Wiring between the drive and motor exceeds 150 m</li> <li>• A large amount of starting torque is required</li> <li>• An AC reactor is installed</li> </ul> |
| 9       | 50 Hz, high starting torque |                      |   |
| A       | 60 Hz, mid starting torque  |                      |   |
| B       | 60 Hz, high starting torque |                      |   |
| C       | 90 Hz (with 60 Hz base)     | Constant output      | When operating at greater than 60 Hz the output voltage will be constant.   |
| D       | 120 Hz (with 60 Hz base)    |                      |   |
| E       | 180 Hz (with 60 Hz base)    |                      |   |

The following tables show details on predefined V/f patterns.

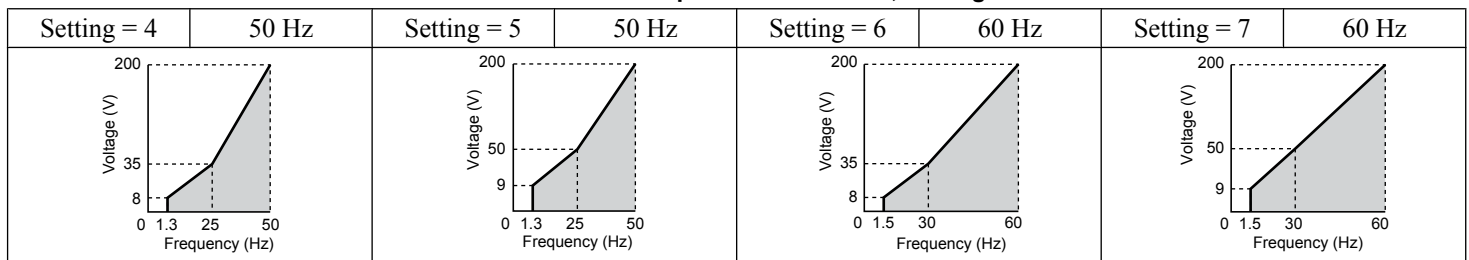
The following graphs are for 200 V class drives; double the values for 400 V class drives.

### Predefined V/f Patterns for 0.1 to 3.7 kW Drives

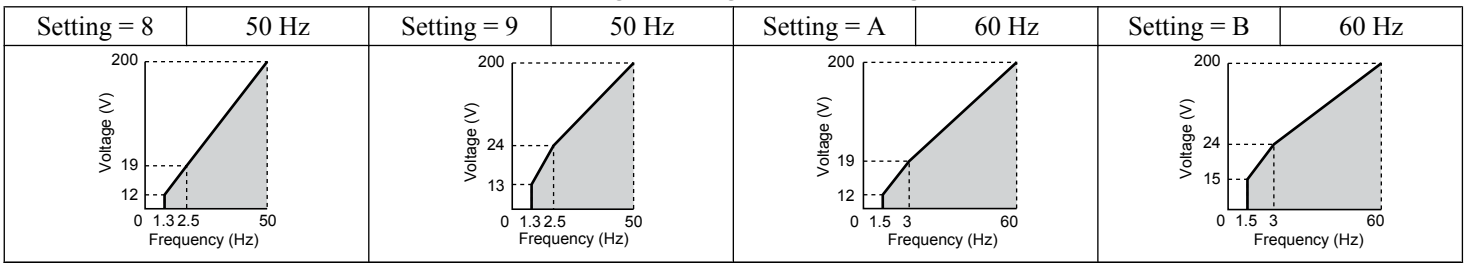
**Table 5.12 Constant Torque Characteristics, Settings 0 to 3**



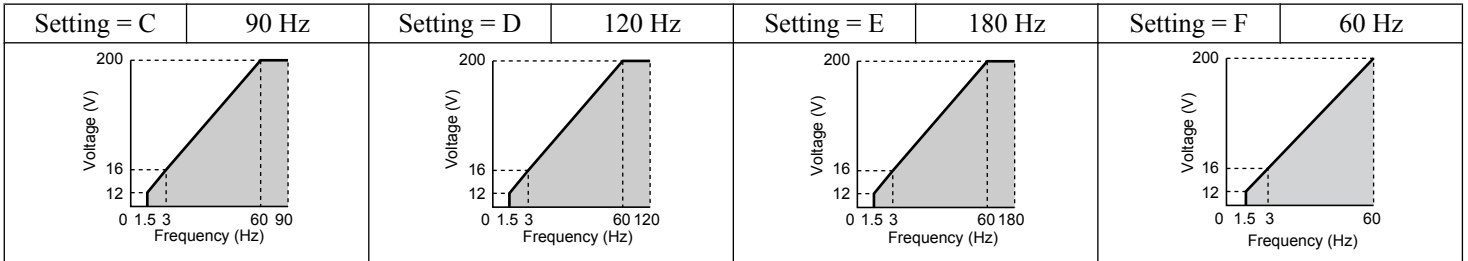
**Table 5.13 Derated Torque Characteristics, Settings 4 to 7**



**Table 5.14 High Starting Torque, Settings 8 to B**



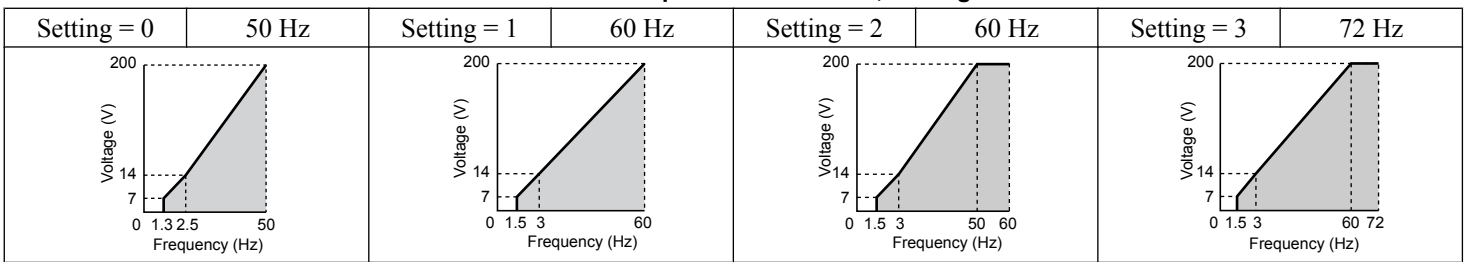
**Table 5.15 Rated Output Operation, Settings C to F**



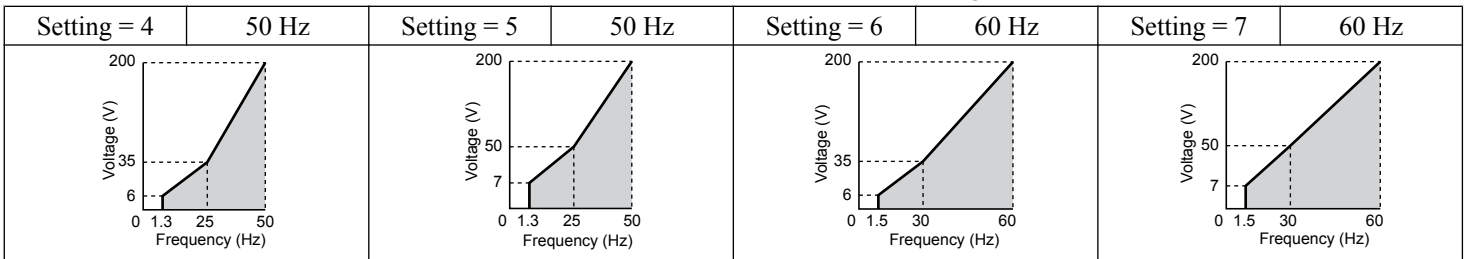
**Predefined V/f Patterns for 5.5 to 18.5 kW Drives**

The following graphs are for 200 V class drives. Double values when using a 400 V class drive.

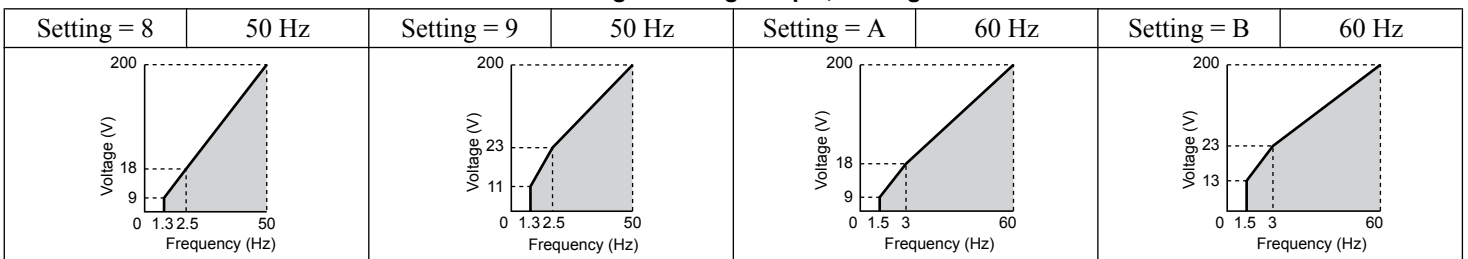
**Table 5.16 Rated Torque Characteristics, Settings 0 to 3**



**Table 5.17 Derated Torque Characteristics, Settings 4 to 7**

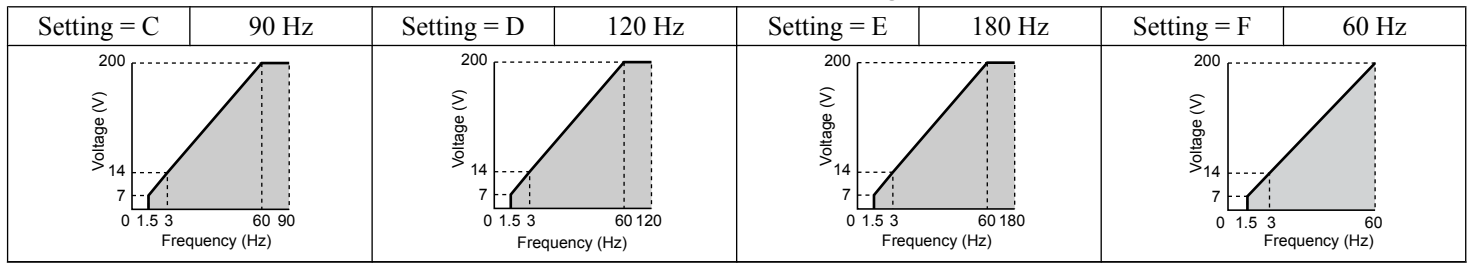


**Table 5.18 High Starting Torque, Settings 8 to B**



## 5.5 E: Motor Parameters

**Table 5.19 Constant Output, Settings C to F**



### Setting a Custom V/f Pattern

Setting parameter E1-03 to “F” allows to set up a custom V/f pattern by changing parameters E1-04 to E1-13.

When E1-03 is changed to “F”, the default values for parameters E1-04 to E1-13 will be equal to V/f pattern 1 of the predefined patterns.

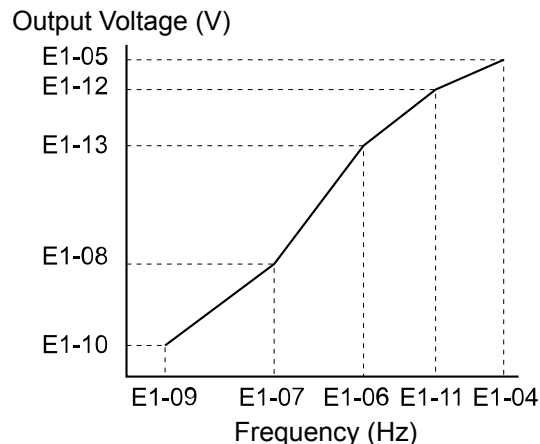
### ■ V/f Pattern Settings E1-04 to E1-13

Using parameters E1-04 through E1-13, the user can either monitor the V/f pattern values if  $E1-03 \leq 15$  or set up a custom V/f pattern as shown in [Figure 5.38](#) when  $E1-03 = F$ .

| No.       | Parameter Name                    | Setting Range      | Default    |
|-----------|-----------------------------------|--------------------|------------|
| E1-04     | Maximum Output Frequency          | 40.0 to 400.0 Hz   | 60.0 Hz    |
| E1-05     | Maximum Voltage                   | 0.0 to 255.0 V <1> | 230 V <1>  |
| E1-06     | Base Frequency                    | 0.0 to E1-04       | 60.0 Hz    |
| E1-07     | Middle Output Frequency           | 0.0 to E1-04       | 3.0 Hz     |
| E1-08     | Middle Output Frequency Voltage   | 0.0 to 255.0 V <1> | 18.4 V <1> |
| E1-09     | Minimum Output Frequency          | 0.0 to E1-04       | 1.5 Hz     |
| E1-10     | Minimum Output Frequency Voltage  | 0.0 to 255.0 V <1> | 13.8 V <1> |
| E1-11     | Middle Output Frequency 2         | 0.0 to E1-04       | 0.0 Hz     |
| E1-12     | Middle Output Frequency Voltage 2 | 0.0 to 255.0 V <1> | 0.0 V      |
| E1-13 <2> | Base Voltage                      | 0.0 to 255.0 Hz    | 0.0 V      |

<1> Values shown are for 200 V class drives; double the value when using 400 V class drives.

<2> When E1-13 is set to 0.0 V, the drive uses the value set in E1-05 to control the voltage.



**Figure 5.38 V/f Pattern**

- Note:**
1. The following condition must be true when setting up the V/f pattern:  $E1-09 \leq E1-07 < E1-06 \leq E1-11 \leq E1-04$
  2. Setting E1-11 to 0 disables both E1-11 and E1-12 and the above conditions do not apply.
  3. To make the V/f pattern a straight line set  $E1-09 = E1-07$ . In this case the E1-08 setting is disregarded.
  4. E1-03 is unaffected when the drive is initialized using parameter A1-03, but the settings for E1-04 through E1-13 are returned to their default values.

## ◆ E2: Motor 1 Parameters

These parameters contain the most important motor data needed for optimal motor control. The parameters are set automatically during Auto-Tuning. Set the parameters manually when Auto-Tuning cannot be performed.

### ■ E2-01: Motor Rated Current

Set E2-01 to the full load amps (FLA) stamped on the motor nameplate. During Auto-Tuning the value must be entered to parameter T1-04. If Auto-Tuning completes successfully, the value entered will automatically be saved to E2-01.

| No.   | Parameter Name      | Setting Range   | Default            |
|-------|---------------------|---|--------------------|
| E2-01 | Motor Rated Current | 10% to 200% of the drive rated current.<br>(unit: 0.01 A) | Depending on o2-04 |

- Note:**
1. Display is in the following units:  
BV0006 to BV0018, 2V0006 to 2V0040, and 4V0002 to 4V0023: 0.01 A units.  
2V0056 to 2V0069 and 4V0031 to 4V0038: 0.1 A units.
  2. Change E2-01 only after changing the value set to E2-03. Setting E2-01 < E2-03 will trigger an oPE02 error.

### ■ E2-02: Motor Rated Slip

Sets the motor rated slip in Hz. This value is automatically set during Rotational Auto-Tuning.

| No.   | Parameter Name   | Setting Range    | Default            |
|-------|------------------|------------------|--------------------|
| E2-02 | Motor Rated Slip | 0.00 to 20.00 Hz | Depending on o2-04 |

If Auto-Tuning cannot be performed calculate the motor rated slip using the information written on the motor nameplate and the formula below:

$$E2-02 = f - (n \times p)/120$$

(f: rated frequency (Hz), n: rated motor speed (r/min), p: number of motor poles)

### ■ E2-03: Motor No-Load Current

Set E2-03 to the motor no-load current at rated voltage and rated frequency. If Rotational Auto-Tuning completes successfully, this value is automatically calculated. If Auto-Tuning cannot be performed, contact the motor manufacturer for information about the no-load current.

| No.   | Parameter Name        | Setting Range                  | Default            |
|-------|-----------------------|--------------------------------|--------------------|
| E2-03 | Motor No-Load Current | 0 to [E2-01]<br>(unit: 0.01 A) | Depending on o2-04 |

- Note:** Display is in the following units: BV0006 to BV0018, 2V0006 to 2V0040, and 4V0002 to 4V0023: 0.01 A units. 2V0056 to 2V0069 and 4V0031 to 4V0038: 0.1 A units.

### ■ E2-04: Number of Motor Poles

Set the number of motor poles to E2-04. If Auto-Tuning completes successfully, the value entered to T1-06 will automatically be saved to E2-04.

| No.   | Parameter Name        | Setting Range | Default |
|-------|-----------------------|---------------|---------|
| E2-04 | Number of Motor Poles | 2 to 48       | 2       |

### ■ E2-05: Motor Line-to-Line Resistance

Sets the line-to-line resistance of the motor stator winding. If the Auto-Tuning completes successfully, this value is automatically calculated. Remember this value must be entered as line-line and not line-neutral.

| No.   | Parameter Name                | Setting Range     | Default            |
|-------|-------------------------------|-------------------|--------------------|
| E2-05 | Motor Line-to-Line Resistance | 0.000 to 65.000 Ω | Depending on o2-04 |

- Note:** The setting range becomes 0.00 to 130.00 when using BV0002, 2V0002, 4V0001 and smaller.

If Auto-Tuning is not possible, then contact the motor manufacturer to find out the line-to-line resistance or measure it manually. When using the manufacturer Motor Test Report, calculate E2-05 by the formulas below.

- E-type insulation: Multiply 0.92 times the resistance value (Ω) listed on the Test Report at 75 °C

## 5.5 E: Motor Parameters

- B-type insulation: Multiply 0.92 times the resistance value ( $\Omega$ ) listed on the Test Report at 75 °C.
- F-type insulation: Multiply 0.87 times the resistance value ( $\Omega$ ) listed on the Test Report at 115 °C.

### ■ E2-06: Motor Leakage Inductance

Sets the voltage drop due to motor leakage inductance as a percentage of motor rated voltage.

| No.   | Parameter Name           | Setting Range | Default            |
|-------|--------------------------|---------------|--------------------|
| E2-06 | Motor Leakage Inductance | 0.0 to 40.0%  | Depending on o2-04 |

### ■ E2-10: Motor Iron Loss for Torque Compensation

This parameter sets the motor iron loss in watts.

| No.   | Parameter Name                          | Setting Range | Default            |
|-------|---|---------------|--------------------|
| E2-10 | Motor Iron Loss for Torque Compensation | 0 to 65535 W  | Depending on o2-04 |

### ■ E2-11: Motor Rated Power

This parameter sets the motor rated power in kW. During Auto-Tuning the value must entered to parameter T1-02. If Auto-Tuning completes successfully, the value entered will automatically be saved to E2-11.

| No.   | Parameter Name    | Setting Range     | Default            |
|-------|-------------------|-------------------|--------------------|
| E2-11 | Motor Rated Power | 0.00 to 650.00 kW | Depending on o2-04 |



## 5.6 F: Option Settings

### ◆ F6: Serial Communications Option Card Settings

These parameters configure communication option cards and communication fault detection methods.

#### ■ F6-01: Communications Error Operation Selection

Determines drive operation if a communication error occurs.

| No.   | Parameter Name                           | Setting Range | Default |
|-------|--|---------------|---------|
| F6-01 | Communications Error Operation Selection | 0 to 5        | 1       |

**Setting 0: Ramp to Stop Using Current Accel/Decel Time**

**Setting 1: Coast to Stop**

**Setting 2: Fast-stop Using C1-09**

**Setting 3: Alarm Only, Continue Operation**

**Setting 4: Alarm and Run at d1-04**

**Note:** Take proper safety measures, such as installing an emergency stop switch, as the drive will continue operation when detecting an bUS error.

**Setting 5: Alarm and Ramp to stop**

#### ■ F6-02: External Fault from Comm. Option Detection Selection

Determines the detection method of an external fault initiated by a communication option (EF0).

| No.   | Parameter Name                             | Setting Range | Default |
|-------|--|---------------|---------|
| F6-02 | External Fault from Comm. Option Selection | 0 or 1        | 0       |

**Setting 0: Always Detected**

**Setting 1: Detection During Run Only**

#### ■ F6-03: External Fault from Comm. Option Operation Selection

Determines the operation when an external fault is initiated by a communication option (EF0).

| No.   | Parameter Name                                       | Setting Range | Default |
|-------|--|---------------|---------|
| F6-03 | External Fault from Comm. Option Operation Selection | 0 to 3        | 1       |

**Setting 0: Ramp to Stop Using Current Accel/Decel Time**

**Setting 1: Coast to Stop**

**Setting 2: Fast-stop Using C1-09**

**Setting 3: Alarm Only, Continue Operation**

#### ■ F6-04: bUS Error Detection Time

Sets the delay time for bUS error detection.

| No.   | Parameter Name           | Setting Range | Default |
|-------|--------------------------|---------------|---------|
| F6-04 | bUS Error Detection Time | 0.0 to 5.0 s  | 2.0 s   |

## 5.6 F: Option Settings

---

### ■ F6-07: NetRef/ComRef Function Selection

Selects how multi-step speed inputs are treated when the NetRef command is set.

| No.   | Parameter Name                   | Setting Range | Default |
|-------|----------------------------------|---------------|---------|
| F6-07 | NetRef/ComRef Function Selection | 0 or 1        | 0       |

#### Setting 0: Multi-Step Speed Operation Disabled

If the NetRef command is selected, multi-step speed input frequency references are disabled. This is the same as Yaskawa F7 drives.

#### Setting 1: Multi-Step Speed Operation Enabled

Multi-step speed inputs are active and can override the frequency reference from the communications option even when the NetRef command is selected. This is the same as Yaskawa F7 drives.

### ■ F6-08: Reset Communication Parameters

Determines whether communication-related parameters (F6-□□ and F7-□□) are reset when the drive is initialized using A1-03.

| No.   | Parameter Name                 | Setting Range | Default |
|-------|--------------------------------|---------------|---------|
| F6-08 | Reset Communication Parameters | 0 or 1        | 0       |

#### Setting 0: Do Not Reset Parameters F6-□□ and F7-□□ when the Drive Is Initialized with A1-03

#### Setting 1: Reset F6-□□ and F7-□□ when the Drive Is Initialized with A1-03

**Note:** F6-08 is not reset when the drive is initialized, but does determine whether initializing the drive with A1-03 resets communication parameters F6-□□ and F7-□□.

---

### ◆ MECHATROLINK-II Parameters

Parameters F6-20 through F6-26 set up the drive to operate on a MECHATROLINK-II network. Refer to the option manual for details on parameter settings.

---

### ◆ MECHATROLINK-III Parameters

Parameters F6-20, F6-21, and F6-23 through F6-26 set up the drive to operate on a MECHATROLINK-III network. Refer to the option manual for details on parameter settings.

---

### ◆ PROFIBUS-DP Parameters

Parameters F6-30 through F6-32 set up the drive to operate on a PROFIBUS-DP network. Refer to the option manual for details on parameter settings.

---

### ◆ DeviceNet Parameters

Parameters F6-50 through F6-63 set up the drive to operate on a DeviceNet network. Refer to the option manual for details on parameter settings.

---

### ◆ F7-01 to F7-42: EtherNet/IP and Modbus TCP/IP Option Parameters

F7-□□ parameters are reserved for use with SI-EN3/V and SI-EM3/V options. Refer to the Option Installation Manuals for details.

## 5.7 H: Terminal Functions

H parameters are used to assign functions to the external terminals.

### ◆ H1: Multi-Function Digital Inputs

#### ■ H1-01 to H1-07: Functions for Terminals S1 to S7

These parameters assign functions to the multi-function digital inputs.

| No.   | Parameter Name  | Setting Range | Default  |
|-------|---|---------------|--|
| H1-01 | Multi-Function Digital Input Terminal S1 Function Selection | 2 to B0       | 40 (F) </> : Forward Run Command (2-Wire sequence) |
| H1-02 | Multi-Function Digital Input Terminal S2 Function Selection | 2 to B0       | F: Through Mode                                    |
| H1-03 | Multi-Function Digital Input Terminal S3 Function Selection | 0 to B0       | 26: External Pump Fault                            |
| H1-04 | Multi-Function Digital Input Terminal S4 Function Selection | 0 to B0       | 14: Fault Reset                                    |
| H1-05 | Multi-Function Digital Input Terminal S5 Function Selection | 0 to B0       | 8D (0) </> : Multi Setpoint 1                      |
| H1-06 | Multi-Function Digital Input Terminal S6 Function Selection | 0 to B0       | 80 (3) </> : HAND Mode                             |
| H1-07 | Multi-Function Digital Input Terminal S7 Function Selection | 0 to B0       | 81 (4) </> : HAND Mode 2                           |

<1> Number appearing in parenthesis is the default value after performing a 3-Wire initialization (A1-03 = 3330).

#### Setting 0: 3-Wire Sequence

The digital input programmed for 3-Wire control becomes the forward/reverse directional input, S1 becomes the Run command input, and S2 becomes the Stop command input.

The drive starts the motor when the input S1 set for the Run command closes for longer than 2 ms. The drive stops the operation when the Stop input S2 releases for 2 ms. When the digital input programmed for a forward/reverse operation is open, the drive is set for forward operation. When the digital input is closed, the drive is set for reverse operation.

**Note:** Input the Run and Stop commands via S1 and S2 when selecting a 3-Wire sequence.

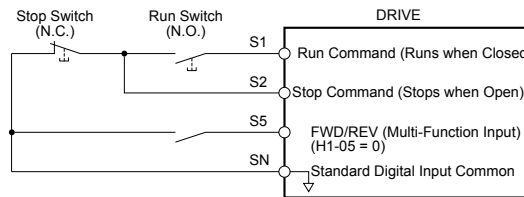


Figure 5.39 3-Wire Sequence Wiring Diagram

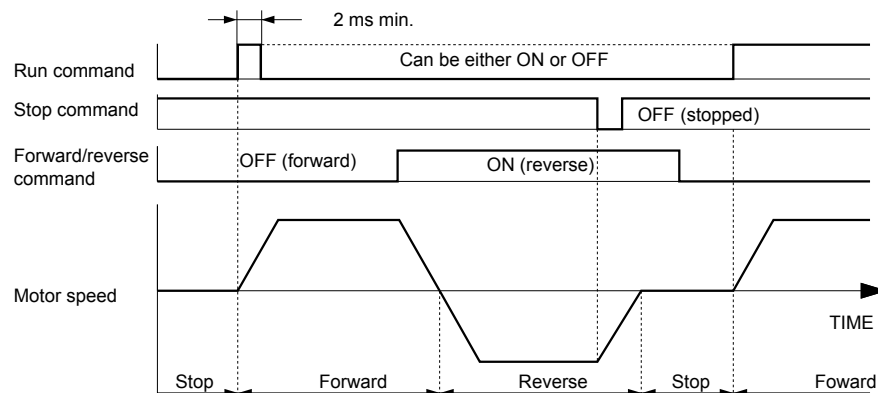


Figure 5.40 3-Wire Sequence

- Note:**
1. The Run command must be closed for more than 2 ms.
  2. If the Run command is active at power up and b1-17 = 0 (Run command at power up not accepted), the Run LED will flash to indicate that protective functions are operating. If required by the application, set b1-17 to 1 to automatically issue the Run command upon drive power up.

## 5.7 H: Terminal Functions

**WARNING! Sudden Movement Hazard.** Ensure start/stop and safety circuits are wired properly and in the correct state before applying power to the drive. Failure to comply could result in death or serious injury from moving equipment.

**WARNING! Sudden Movement Hazard.** The drive may start unexpectedly in reverse direction after power up if it is wired for 3-Wire sequence but set up for 2-Wire sequence (default). Make sure b1-17 is set to "0" (drive does not accept a Run command active at power up). When initializing the drive use 3-Wire initialization. Failure to comply could result in death or serious injury from moving equipment.

### Setting 2: External Reference 1/2 Selection

Switches between two different sources of Run Commands and Frequency References. When multi-function digital input selection 2 (Ext Ref Sel) is programmed, the Run Command and Frequency Reference source can be switched between External Reference 1 (b1-01/b1-02) and External Reference 2 (b1-15/b1-16) if the drive is in AUTO mode.

### Settings 3 to 5: Multi-Step Speed Reference 1 to 3

Switches multi-step speed frequency references d1-01 to d1-08 by digital inputs.

### Setting 6: Jog Reference Selection

The Jog frequency set in parameter d1-17 becomes the frequency reference when the input terminal closes.

### Setting 7: Accel/Decel Time Selection 1

Switches between accel/decel times 1 (C1-01 and C1-02) and 2 (C1-03 and C1-04). *Refer to C1-01 to C1-04: Accel, Decel Times 1 and 2 on page 140* for details.

### Settings 8 and 9: Baseblock Command (N.O., N.C.)

When the drive receives a baseblock command, the output transistors stop switching, the motor coasts to stop, and a bb alarm flashes on the digital operator to indicate baseblock. When baseblock ends while a Run command is active, the drive performs Speed Search to restart the motor.

| Digital Input Function | Drive Operation              |                              |
|------------------------|------------------------------|------------------------------|
|                        | Input Open                   | Input Closed                 |
| Setting 8 (N.C.)       | Baseblock (Interrupt output) | Normal operation             |
| Setting 9 (N.O.)       | Normal operation             | Baseblock (Interrupt output) |

**WARNING! Sudden Movement Hazard.** When using a mechanical holding brake with the drive in a lifting application, close the brake when the drive output is cut off by a baseblock command triggered by one of the input terminals. Failure to comply will result in a slipping load from the motor suddenly coasting when the baseblock command is entered and may cause serious injury or death.

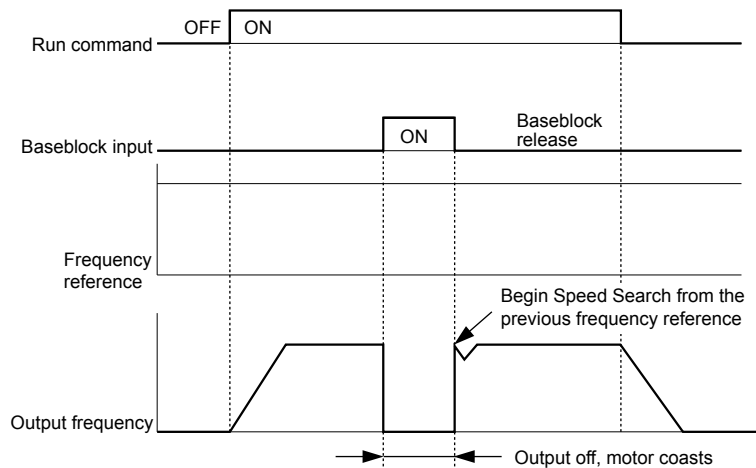


Figure 5.41 Baseblock Operation During Run

### Setting A: Accel/Decel Ramp Hold

When the digital input programmed for the Accel/decel ramp hold function closes, the drive locks (holds) the output frequency. Acceleration or deceleration resumes when the input is reopened.

If the Accel/decel ramp hold function is enabled (d4-01 = 1), the drive saves the output frequency to memory when the Ramp Hold input is closed. When the drive is restarted after stop or after power supply interruption, the saved output frequency becomes the frequency reference (provided that the Accel/decel ramp hold input is still closed).

### Setting B: Drive Overheat Alarm (oH2)

Triggers an oH2 alarm when the contact closes. Drive operation is not affected because this is an alarm.

**Setting C: Analog Terminal Input Selection (Terminal A1, A2)**

When closed, the terminals specified in H3-14 are enabled. When open, the drive disregards the input signal to the analog terminals.

**Setting F: Not Used/Through Mode**

Select this setting when using the terminal in a pass-through mode. When set to F, an input does not trigger any function in the drive. Setting F, however, still allows the input status of the terminal (open or closed) to be read out by a PLC via a communication option or MEMOBUS/Modbus communications. The drive input terminals can then be used as remote I/O by the PLC.

**Settings 10 and 11: Up/Down Function**

The Up/Down function allows the frequency reference to be set by two push buttons when one digital input is programmed as the Up input (H1-□□ = 10) to increase the frequency reference and the other digital input is programmed as the Down input (H1-□□ = 11) to decrease the frequency reference.

The Up/Down function takes priority over the frequency references from the digital operator, the analog inputs, and the pulse input (b1-01 = 0, 1, 4). When using the Up/Down function, references provided by these sources will be disregarded.

The inputs operate as shown in [Table 5.20](#):

**Table 5.20 Up, Down Command**

| Status  |           | Drive Operation                  |
|---------|-----------|----------------------------------|
| Up (10) | Down (11) |                                  |
| Open    | Open      | Hold current frequency reference |
| Closed  | Open      | Increase frequency reference     |
| Open    | Closed    | Decrease frequency reference     |
| Closed  | Closed    | Hold current frequency reference |

- Note:**
1. An oPE03 alarm occurs when only one of the Up/Down functions is programmed to a digital input.
  2. An oPE03 alarm occurs when the Up/Down function is assigned to the terminals and a different digital input is programmed for the Accel/decel ramp hold function. For more information on alarms, [Refer to Drive Faults, Alarms, Errors, and Messages on page 252](#).
  3. The Up/Down function can only be used for External reference 1. Consider this when using Up/Down and the external reference switching command (H1-□□ = 2).

**Using the Up/Down Function with Frequency Reference Hold (d4-01)**

- If the frequency reference hold function is disabled (d4-01 = 0), the Up/Down frequency reference will be reset to 0 when the Run command is cleared or the power is cycled.
- When d4-01 = 1, the drive will save the frequency reference set by the Up/Down function. When the Run command or the power is cycled, the drive will restart with the saved reference value. Close the Up or Down input without an active Run command to reset the saved value.

**Using the Up/Down Function with Frequency Reference Limits**

Parameter d2-01 determines the upper frequency reference limit.

The value for the lower frequency reference limit depends on the parameter d4-10 setting. This value can be set by an analog input or parameter d2-02. When a Run command is applied, the lower limits function as follows:

- If the lower limit is set by d2-02 only, the drive accelerates to this limit as soon as a Run command is entered.
- If the lower limit is determined by an analog input only, the drive accelerates to the limit when both the Run command and an Up or Down command are active. The drive will not start running if only the Run command is active.
- If the lower limit is set by both an analog input and d2-02, and the analog limit is higher than the d2-02 value, the drive accelerates to the d2-02 value when a Run command is input. When the d2-02 value is reached, the drive accelerates to the analog limit only if an Up or Down command is set.

[Figure 5.42](#) shows an Up/Down function example with a lower frequency reference limit set by d2-02, and the frequency reference hold function both enabled and disabled.

## 5.7 H: Terminal Functions

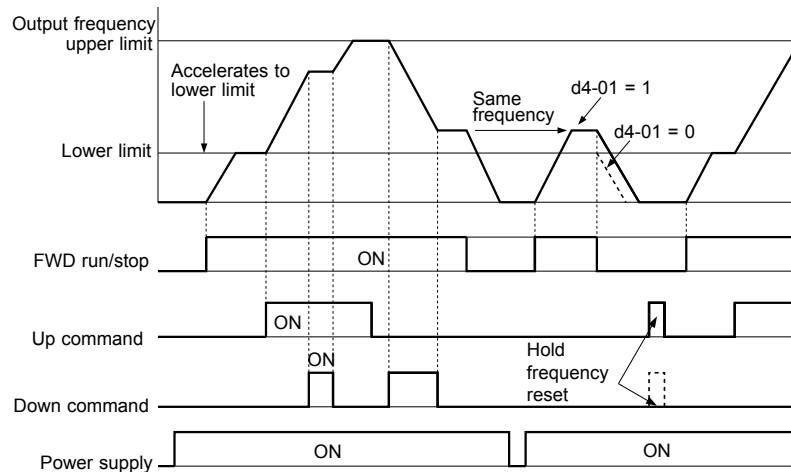


Figure 5.42 Up/Down Command Operation

### Settings 12 and 13: Forward Jog, Reverse Jog

Digital inputs programmed as Forward Jog (H1-□□ = 12) and Reverse Jog (H1-□□ = 13) are Jog inputs that do not require a Run command. Closing the terminal set for Forward Jog input will cause the drive to ramp to the Jog frequency reference (d1-17) in the forward direction. The Reverse Jog will cause the same action in the reverse direction. The Forward Jog and Reverse Jog command can be set independently.

**Note:** The Forward Jog and Reverse Jog commands override all other frequency references. However, if the drive is set to prohibit reverse rotation (b1-04 = 1), activating Reverse Jog will have no effect. Inputting both the Forward Jog and Reverse Jog are simultaneously for 500 ms or longer will trigger an alarm will and the drive will ramp to stop.

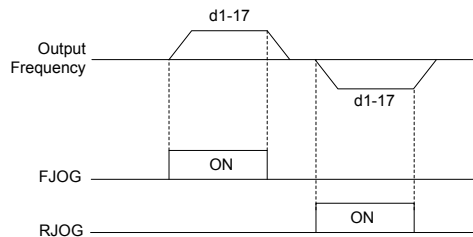


Figure 5.43 FJOG/RJOG Operation

### Setting 14: Fault Reset

When the drive detects a fault condition, the fault output contact closes, the drive output shuts off, and the motor coasts to stop (specific stopping methods can be selected for some faults such as L1-04 for motor overheat). After removing the Run command, clear the fault either by pressing the RESET key on the digital operator or closing a digital input configured as a Fault Reset (H1-□□ = 14).

**Note:** Remove the Run command prior to resetting a fault. Fault Reset commands are ignored while the Run command is present.

### Settings 15 and 17: Fast Stop (N.O., N.C.)

The Fast Stop function operates similar to an emergency stop input to the drive. If a Fast Stop command is input while the drive is running, the drive decelerates to a stop in the deceleration time set to C1-09. The drive can only be restarted after bringing the drive to a complete stop, turning off the Fast Stop input, and switching off the Run command.

- To trigger the Fast Stop function with an N.O. switch, set H1-□□ = 15.
- To trigger the Fast Stop function with an N.C. switch, set H1-□□ = 17.

Figure 5.44 shows an operation example of Fast Stop.

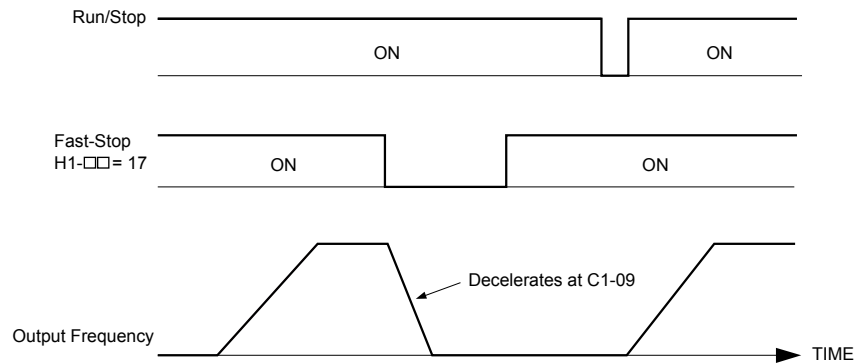


Figure 5.44 Fast Stop Sequence

**NOTICE:** Rapid deceleration can trigger an overvoltage fault. When faulted, the drive output shuts off, and the motor coasts. To avoid this uncontrolled motor state and to ensure that the motor stops quickly and safely, set an appropriate Fast Stop time to C1-09.

#### Setting 18: Timer Function Input

This setting configures a digital input terminal as the input for the timer function. Use this setting combination with the timer function output (H2-□□ = 12).

#### Setting 19: PID Disable

Close a digital input to indefinitely disable the PID function. When the input is released, the drive resumes PID operation.

#### Setting 1B: Program Lockout

Parameter values cannot be changed when an input is programmed for Program Lockout and the input is open. It is still possible, however, to view and monitor parameter settings.

#### Setting 1E: Reference Sample Hold

This function allows the user to sample an analog frequency reference signal being input to terminal A1, A2, or A3 and hold the frequency reference at the sampled level. When the Analog Frequency Reference Sample/Hold function is held for at least 100 ms, the drive reads the analog input and changes the frequency reference to the newly sampled speed as illustrated in [Figure 5.45](#).

When the power is shut off and the sampled analog frequency reference is cleared, the frequency reference is reset to 0.

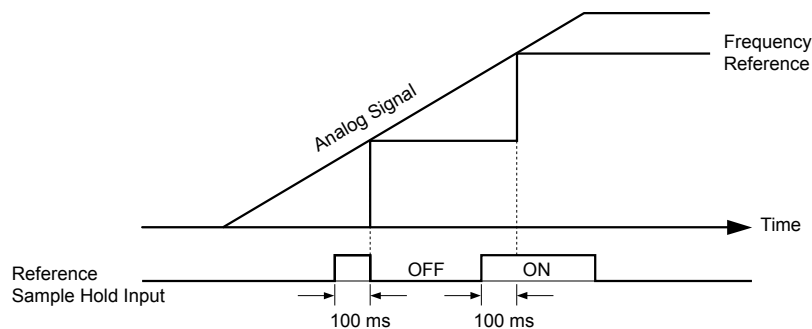


Figure 5.45 Analog Frequency Reference Sample/Hold

An oPE03 error will occur when one of the following functions is used simultaneously with the Analog frequency reference sample/hold command:

- Hold accel/decel stop (setting: A)
- Up command, Down command (setting: 10, 11)
- Up or Down functions (setting: 75, 76)

#### Settings 20 to 2F: External Fault

The External fault command stops the drive when problems occur with external devices.

To use the External fault command, set one of the multi-function digital inputs to a value between 20 and 2F. The digital operator will display EF□ where □ is the number of the terminal to which the external fault signal is assigned.

For example, if an external fault signal is input to terminal S3, “EF3” will be displayed.

## 5.7 H: Terminal Functions

Select the value to be set in H1-□□ from a combination of any of the following three conditions:

- Signal input level from peripheral devices (N.O., N.C.)
- External fault detection method
- Operation after external fault detection

An “On-Delay” timer will be applied to the external fault if it is “Normally Open” and an “Off-Delay” timer will be applied to the external fault if it is “Normally Closed”.

If the external fault is set to “During Run”, the time delay will start after the Run command is received.

Refer to [Figure 5.46](#) to [Figure 5.48](#) for details.

[Table 5.21](#) shows the relationship between the conditions and the value set to H1-□□:

Terminal statuses, detection conditions, and stopping methods marked with an “O” are applicable to the corresponding settings.

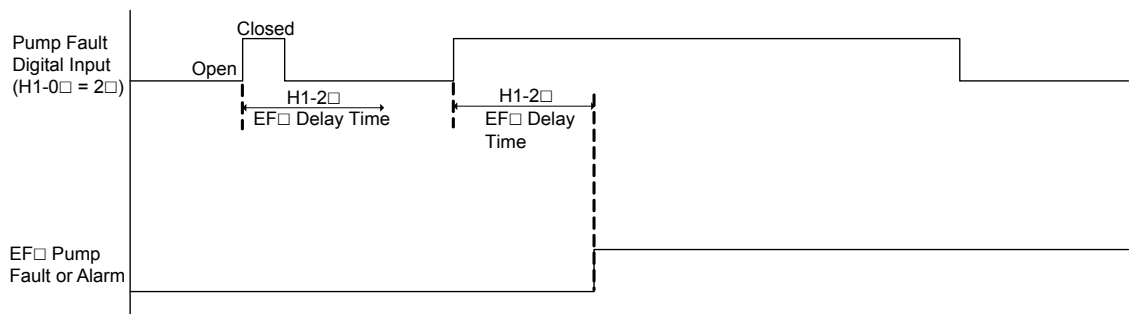
**Table 5.21 Stopping Method for External Fault**

| Setting | Terminal Status <1> |      | Detection Conditions <2> |                          | Stopping Method      |                       |                   |                               |
|---------|---------------------|------|--------------------------|--------------------------|----------------------|-----------------------|-------------------|-------------------------------|
|         | N.O.                | N.C. | Always Detected          | Detected during Run only | Ramp to Stop (fault) | Coast to Stop (fault) | Fast Stop (fault) | Alarm Only (continue running) |
| 20      | O                   |      | O                        |                          | O                    |                       |                   |                               |
| 21      |                     | O    | O                        |                          | O                    |                       |                   |                               |
| 22      | O                   |      |                          | O                        | O                    |                       |                   |                               |
| 23      |                     | O    |                          | O                        | O                    |                       |                   |                               |
| 24      | O                   |      | O                        |                          |                      | O                     |                   |                               |
| 25      |                     | O    | O                        |                          |                      | O                     |                   |                               |
| 26      | O                   |      |                          | O                        |                      | O                     |                   |                               |
| 27      |                     | O    |                          | O                        |                      | O                     |                   |                               |
| 28      | O                   |      | O                        |                          |                      |                       | O                 |                               |
| 29      |                     | O    | O                        |                          |                      |                       | O                 |                               |
| 2A      | O                   |      |                          | O                        |                      |                       | O                 |                               |
| 2B      |                     | O    |                          | O                        |                      |                       | O                 |                               |
| 2C      | O                   |      | O                        |                          |                      |                       |                   | O                             |
| 2D      |                     | O    | O                        |                          |                      |                       |                   | O                             |
| 2E      | O                   |      |                          | O                        |                      |                       |                   | O                             |
| 2F      |                     | O    |                          | O                        |                      |                       |                   | O                             |

<1> Determine the terminal status for each fault, i.e., whether the terminal is normally open or normally closed.

<2> Determine whether detection for each fault should be enabled only during run or always detected.

**External Pump Fault (or Alarm) N.O. Always Detected**



**Figure 5.46 External Pump Fault and Alarm N.O. Always Detected**



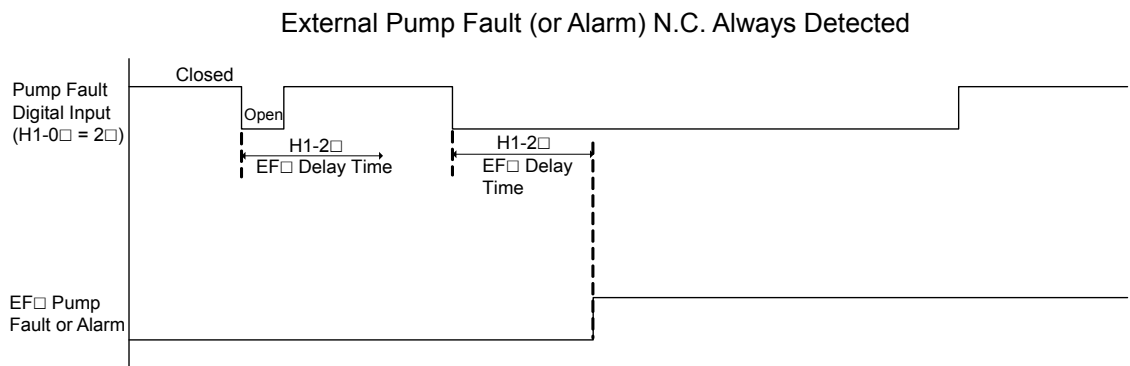


Figure 5.47 External Pump Fault and Alarm N.C. Always Detected

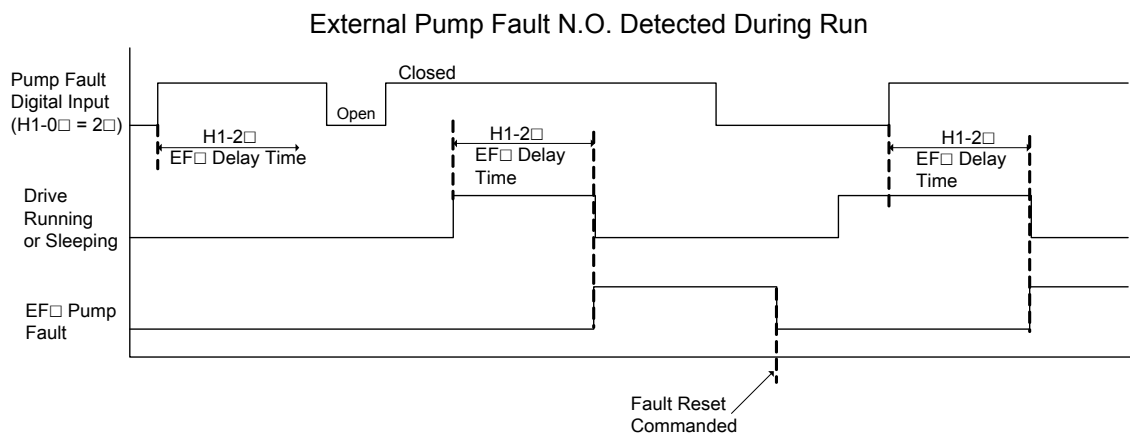


Figure 5.48 External Pump Fault N.O. Detected During Run

**Setting 30: PID Integral Reset**

Configuring one of the digital inputs for PID integral reset ( $H1-\square\square = 30$ ) resets the value of the integral component in PID control to 0 when the terminal is closed.

**Setting 31: PID Integral Hold**

Configuring a digital input for Integral Hold ( $H1-0\square = 31$ ) locks the value of the integral component of the PID control as long as the input is active. The PID controller resumes integral operation from the hold value as soon as the integral hold input is released.

**Setting 32: Multi-Step Speed Reference 4**

Selects the multi-step speeds d1-09 to d1-16 in combination with the input terminal set for Multi-Step Speed 1, 2 and 3.

**Setting 34: PID Soft Starter Cancel**

A digital input configured as a PID soft starter cancel input ( $H1-0\square = 34$ ) enables or disables the PID soft starter and cancels the PID accel/decel time (b5-17).

**Setting 35: PID Input Level Selection**

Allows an input terminal to switch the sign of the PID input.

**Settings 40 and 41: Forward Run, Reverse Run Command for 2-Wire Sequence**

Configures the drive for a 2-Wire sequence.

When an input terminal set to 40 closes, the drive operates in the forward direction. When an input set for 41 closes, the drive operates in reverse. Closing both inputs simultaneously will result in an external fault.

- Note:**
1. This function cannot be used simultaneously with settings 42 and 43.
  2. The same functions are assigned to terminals S1 and S2 when the drive is initialized for 2-Wire sequence.

## 5.7 H: Terminal Functions

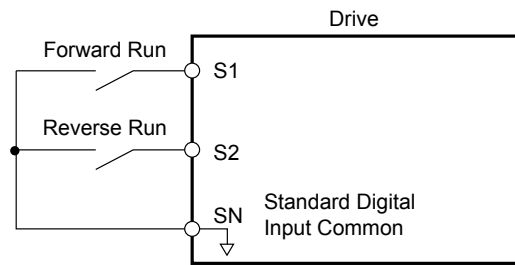


Figure 5.49 Example Wiring Diagram for 2-Wire Sequence

### Settings 42 and 43: Run and Direction Command for 2-Wire Sequence 2

Sets the drive for 2-Wire sequence 2.

When an input terminal programmed for 42 closes, the drive will operate in the selected direction. The drive will stop when the input opens.

The input programmed for 43 selects the direction. If the input is open, forward direction is selected. If the input is closed, reverse direction is selected.

**Note:** This function cannot be used simultaneously with settings 40 and 41.

### Setting 47: Node Setup

If the SI-S3 option card is connected, closing this terminal sets a node address for operation on a CANopen network.

### Setting 60: DC Injection Braking Command

DC Injection Braking is activated when a DC Injection Braking command is input while the drive is stopped. DC Injection Braking is released when a Run command or a Jog command is input.

The diagram below illustrates DC Injection Braking:

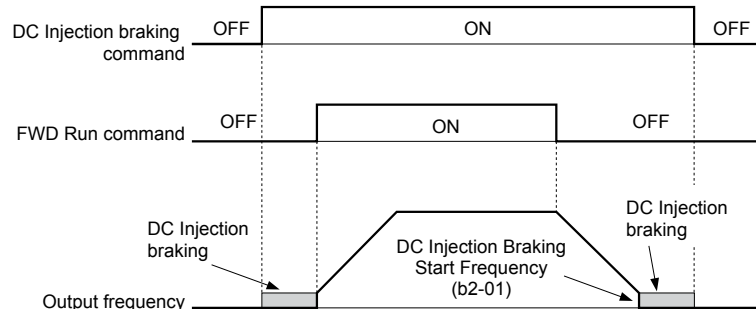


Figure 5.50 DC Injection Braking Input Timing Diagram

### Settings 61 and 62: External Speed Search Command 1, 2

These input functions enable Speed Search even if parameter b3-01 = 0 (no Speed Search at start).

**Note:** Assigning Speed Search 1 and Speed Search 2 to input terminals will trigger an oPE03 error.

### Settings 65 and 66: KEB Ride-Thru 1 (N.C.), 2 (N.O.)

Enables the KEB Ride-Thru function selected in parameter L2-29.

| Digital Input Function | Drive Operation            |                            |
|------------------------|----------------------------|----------------------------|
|                        | Input Open                 | Input Closed               |
| Setting 65 (N.C.)      | KEB Ride-Thru Deceleration | Normal operation           |
| Setting 66 (N.O.)      | Normal operation           | KEB Ride-Thru Deceleration |

**Note:** Simultaneously assigning KEB Ride-Thru 1 and KEB Ride-Thru 2 to the input terminals will trigger an oPE03 error.

### Setting 67: Communication Test Mode

The drive has a built-in function to self-diagnose serial communications operation. The test involves wiring the send and receive terminals of the RS-422/RS-485 port together. The drive transmits data and then confirms that the communications are received normally.

**Setting 6A: Drive Enable**

A digital input configured as a “Drive enable” (H1-□□ = 6A) will prevent the drive from executing a Run command until the input is closed. When the input is open, the digital operator will display “dnE” to indicate that the drive is disabled.

If a Run command is enabled before the terminal set for “Drive enable” closes, then the drive will not run until the Run command is cycled (i.e., a new Run command is required). If the input is opened while the drive is running, the drive will stop according to the stop method set to b1-03. *Refer to b1-03: Stopping Method Selection on page 118* for details.

**Setting 73: Low City Press**

Indicates that sufficient or insufficient pressure is present on the inlet to the pump. Used mainly for pressure booster situations.

**Settings 75 and 76: Up 2/Down 2 Function**

The Up/Down 2 function adds a bias to the frequency reference. The input programmed for 75 will increase the bias and the input programmed for 76 will decrease the bias. *Table 5.22* explains how the Up/Down 2 function works depending on the frequency reference source and parameters d4-01, d5-03, and d4-05.

- Note:**
1. The Up/Down 2 functions must be set as a pair.
  2. When using the Up/Down 2 function, set appropriate bias limit values to parameters d4-08 and d4-09.

**Table 5.22 Up/Down 2 Operations**

| Condition | Freq. Ref. Source          | d4-03              | d4-05 | d4-01 | Operation  | Frequency Saved  |
|-----------|----------------------------|--------------------|-------|-------|--|--|
| 1         | Multi-Step Speed Reference | 0                  | 0     | 0     | <ul style="list-style-type: none"> <li>Accelerates (increases the bias) while the Up 2 terminal is closed.</li> </ul>  | Not saved  |
| 2         |                            |                    |       | 1     | <ul style="list-style-type: none"> <li>Decelerates (decreases the bias) while Down 2 is closed.</li> <li>Holds output frequency (holds the bias) when no Up 2 or Down 2 input or both active.</li> <li>Resets the bias when the reference changes.</li> <li>Operates with the frequency reference in all other situations.</li> </ul>              | If the bias and frequency reference are constant for 5 s, the bias is added to the active frequency reference and reset afterwards.        |
| 3         |                            |                    |       | --    | <ul style="list-style-type: none"> <li>Accelerates (increases the bias) while the Up 2 terminal is closed.</li> <li>Decelerates (decreases the bias) while Down 2 is closed.</li> <li>Otherwise operates at the frequency reference.</li> </ul>  | Not saved  |
| 4         | Multi-Step Speed Reference | Value other than 0 | --    | 0     | <ul style="list-style-type: none"> <li>When the Up 2 is enabled, the drive accelerates to the frequency reference plus d4-03 (bias is increased for d4-03).</li> <li>When Down 2 is enabled, the drive decelerates to the frequency reference minus d4-03 (bias is decreased for d4-03).</li> </ul>  | Not saved  |
| 5         |                            |                    |       | 1     | <ul style="list-style-type: none"> <li>Holds output frequency (holds the bias) when neither Up/Down 2 inputs are active or both inputs are active.</li> <li>Resets the bias when the reference changes.</li> <li>Operates with the frequency reference in all other situations.</li> </ul>   | If the bias and frequency reference are constant for 5 s, the bias is added to the active frequency reference and reset afterwards.        |
| 6         | Other (analog comm., etc.) | 0                  | 0     | 0     | <ul style="list-style-type: none"> <li>Accelerates (increases the bias) while the Up 2 terminal is closed.</li> <li>Decelerates (decreases the bias) while Down 2 is closed.</li> </ul>  | Not saved  |
| 7         |                            |                    |       | 1     | <ul style="list-style-type: none"> <li>Holds output frequency (holds the bias) when neither Up/Down 2 inputs are active or both inputs are active.</li> <li>If the frequency reference changes for more than the time set to d4-07 during accel/decel, bias value is held until the output frequency meets the reference (speed agree).</li> </ul> | If the bias is constant for 5 s, it is saved to parameter d4-06. The frequency reference cannot be overwritten, so only the bias is saved. |

## 5.7 H: Terminal Functions

| Condition | Freq. Ref. Source         | d4-03              | d4-05 | d4-01 | Operation  | Frequency Saved  |
|-----------|---------------------------|--------------------|-------|-------|--|--|
| 8         | Other (analog comm, etc.) | 0                  | 1     | --    | <ul style="list-style-type: none"> <li>Accelerates (increases the bias) while the Up 2 terminal is closed.</li> <li>Decelerates (decreases the bias) while Down 2 is closed.</li> <li>Otherwise operates at the frequency reference</li> </ul>   | Not saved  |
| 9         |                           | Value other than 0 | --    | 0     | <ul style="list-style-type: none"> <li>When Up 2 is enabled, drive accelerates to the frequency reference plus d4-03 (increases the bias for d4-03).</li> <li>When Down 2 is enabled, drive decelerates to the frequency reference minus d4-03 (decreases the bias for d4-03).</li> <li>If the frequency reference changes for more than d4-07 during accel/decel, bias value is held until the output frequency meets the reference (speed agree).</li> </ul> | Not saved  |
| 10        |                           |                    |       | 1     |  | If the bias is constant for 5 s, it is saved to parameter d4-06. The frequency reference cannot be overwritten, so only the bias is saved. |

### Settings 7A and 7B: KEB Ride-Thru 2 (N.C., N.O.)

An input terminal set to 7A or 7B can trigger Single Drive KEB Ride-Thru during deceleration. L2-29 is disregarded if this is enabled.

| Digital Input Function | Drive Operation              |                              |
|------------------------|------------------------------|------------------------------|
|                        | Input Open                   | Input Closed                 |
| Setting 7A (N.C.)      | Single Drive KEB Ride-Thru 2 | Normal operation             |
| Setting 7B (N.O.)      | Normal operation             | Single Drive KEB Ride-Thru 2 |

**Note:** Simultaneously assigning KEB Ride-Thru 1 and KEB Ride-Thru 2 to the input terminals will trigger an oPE03 error.

### Setting 80: HAND Mode

Closing this input will put the drive in HAND Mode.

If this contact is closed within one second of power-up, the drive will honor the utility delay time.

**Note:** When inputs 80 and 81 are closed simultaneously, input 80 has priority and P5-01 determines the frequency reference.

### Setting 81: HAND Mode 2

Closing this input will put the drive in HAND Mode using P5-05 as a frequency reference.

If this contact is closed within one second of power-up, the drive will honor the utility delay time.

**Note:** When inputs 80 and 81 are closed simultaneously, input 80 has priority and P5-01 determines the frequency reference.

### Settings 83, 84, and 85: Alternate Multi-step Setpoints

These setpoint selections are different from Multi Setpoints 1 and 2 (H1-□□ = 8D/8E) in that each input is dedicated to a setpoint instead of being a binary selection.

**Table 5.23** shows active setpoints based on the Alternate Multi-Setpoint Selections (H1-□□ = 83 to 85):

**Table 5.23 Active Setpoints by H1-□□ Setting**

| Alternate Multi-Setpoint Q1-02<br>H1-□□ = 83 | Alternate Multi-Setpoint Q1-03<br>H1-□□ = 84 | Alternate Multi-Setpoint Q1-04<br>H1-□□ = 85 | Setpoint |
|--|--|--|----------|
| Open   | Open   | Open   | Q1-01    |
| Closed                                       | Open/Closed                                  | Open/Closed                                  | Q1-02    |
| Open   | Closed                                       | Open/Closed                                  | Q1-03    |
| Open   | Open   | Closed                                       | Q1-04    |

### Setting 88: Volute-Thermostat (N.O.)

Closed: Drive will trip on “VLTS - Volute-TStat Flt”.

Open: Thermostat fault not active.

**Note:** Assigning both 88 and 89 to input terminals will trigger a VLTS-Volute-TStat Flt.

### Setting 89: Volute-Thermostat (N.C.)

Closed: Thermostat fault not active.

Open: Drive will trip on “VLTS - Volute-TStat Flt”.

**Note:** Assigning both 88 and 89 to input terminals will trigger a VLTS-Volute-TStat Flt.

**Setting 8C: Disable Pre-Charge**

Close to disable pre-charge.

**Settings 8D and 8E: Multi Setpoints 1 and 2**

Settings 8D and 8E will override all other PID setpoints when closed.

**Table 5.24 Multi Setpoints 1 and 2**

| Multi Setpoint 1<br>(H1-0□ = 8D) | Multi Setpoint 2<br>(H1-0□ = 8E) | Setpoint Source  |
|----------------------------------|----------------------------------|--|
| Open                             | Open                             | Frequency Ref (dependent on b1-01), Setpoint 1 - Q1-01 (when b1-01 = 0), Analog Setpoint (H3-0□ = C), Pulse Input Setpoint (H6-01 = 2), or MEMOBUS setpoint. |
| Closed                           | Open                             | Setpoint 2 – Q1-02   |
| Open                             | Closed                           | Setpoint 3 – Q1-03   |
| Closed                           | Closed                           | Setpoint 4 – Q1-04   |

**Setting 8F: Low Water Level**

Function is active in AUTO Mode during normal operation and is also used with Pre-charge function.

Function depends on P1-30, Low Water Digital Input Configuration, setting.

When P1-30 = 0 (N.O.): Closed: Low Water Level Fault. Open: Reservoir/Tank is filled to normal level.

When P1-30 = 1 (N.C.): Closed: Reservoir/Tank is filled to normal level. Open: Low Water Level Fault.

Pre-charge function uses low water level input as “Tank/Reservoir” feedback to indicate water level reached.

**Setting 90: High Water Level**

Function is active when the drive is running and depends on P1-31, High Water Digital Input Configuration, setting.

When P1-31 = 0 (N.O.): Closed: High Water Level Fault. Open: Reservoir/Tank is filled to normal level.

When P1-30 = 1 (N.C.): Closed: Reservoir/Tank is filled to normal level. Open: High Water Level Fault.

**Setting 95: Remove Drive Disable**

Prevents the drive from running when active for the time set in P4-26. Must be inactive for the time set in P4-27 to allow the drive to run again.

**Note:** Parameter P4-25 determines whether this input is Normally Open or Normally Closed.

**Setting B0: Emergency Override Function**

The Emergency Override function is activated by closing the digital input programmed for Emergency Override Forward Run (H1-□□ = AF) or Emergency Override Reverse Run (H1-□□ = B0).

If H1-□□ = 6A (Drive Enable) is programmed, it must be opened to disable the drive for Emergency Override to take effect. Closing both Emergency Override digital inputs at the same time will trigger an External Fault (EF) error.

When the drive is in Emergency Override, the frequency reference source is dependent on parameter S6-02, Emergency Override Reference Selection. When S6-02 is set to 0 (Use S6-01 Reference), the drive will run at the S6-01 setting. When S6-02 is set to 1 (Use Frequency Ref), the drive will use the currently selected frequency reference (based on b1-01 and HAND/AUTO) as the run speed.

An alarm will flash during Emergency Override indicating that the function is active and the direction the drive is commanded to run.

Resettable faults occurring when Emergency Override is activated will be cleared.

The drive will perform unlimited speed search retries during Emergency Override.

When Emergency Stop is active and Emergency Override is activated, the drive will run in Emergency Override mode.

The CALL (Serial Communication Error) mechanism is deactivated when Emergency Override is activated.

The Emergency Override function has priority over the PID Sleep feature (b5-15/b5-16).

**Setting AF: Emergency Override Forward Run**

Enables Emergency Override Forward Run (Enabled when S6-01 = 1).

**Setting B0: Emergency Override Reverse Run**

Enables Emergency Override Reverse Run (Enabled when S6-01 = 1).

◆ H2: Multi-Function Output

■ H2-01 to H2-03: Terminal MA/MB/MC, P1/PC, and P2/PC Function Selection

The drive has three multi-function output terminals.

| No.   | Parameter Name                                    | Setting Range | Default                     |
|-------|---|---------------|-----------------------------|
| H2-01 | Terminal MA, MB and MC Function Selection (relay) | 0 to 1AA      | E: Fault                    |
| H2-02 | Terminal P1 Function Selection (open-collector)   | 0 to 1AA      | 37: During Frequency Output |
| H2-03 | Terminal P2 Function Selection (open-collector)   | 0 to 1AA      | E: Fault                    |

Setting 0: During Run

Output closes when the drive is outputting a voltage.

| Status | Description   |
|--------|---|
| Open   | Drive is stopped.   |
| Closed | A Run command is input or the drive is in deceleration or DC injection. |

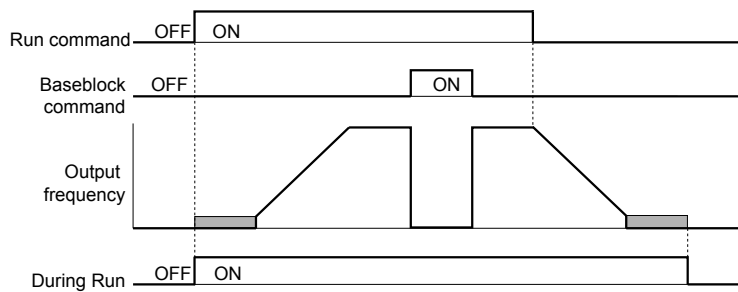


Figure 5.51 During Run Time Chart

Setting 1: Zero Speed

Terminal closes when the output frequency falls below the minimum output frequency set to E1-09 or b2-01.

| Status | Description  |
|--------|--|
| Open   | Output frequency is above the minimum output frequency set to E1-09 or b2-01     |
| Closed | Output frequency is less than the minimum output frequency set to E1-09 or b2-01 |

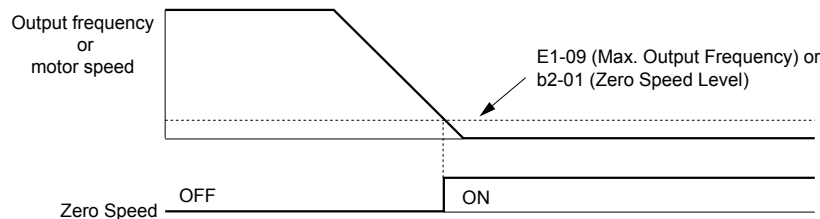


Figure 5.52 Zero-Speed Time Chart

Setting 2: Speed Agree 1 ( $f_{ref}/f_{out}$  Agree 1)

Closes when the actual output frequency is within the Speed Agree Width (L4-02) of the current frequency reference regardless of the direction.

| Status | Description  |
|--------|--|
| Open   | Output frequency or motor speed does not match the frequency reference while the drive is running. |
| Closed | Output frequency or motor speed is within the range of frequency reference $\pm L4-02$ .           |

**Note:** Detection works in forward and reverse.

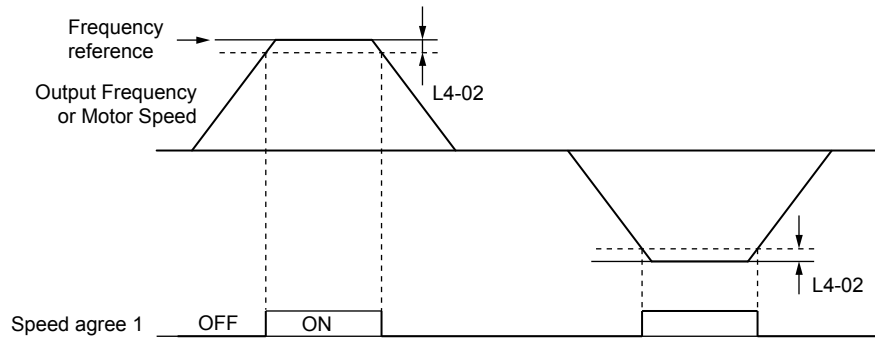


Figure 5.53 Speed Agree 1 Time Chart

**Setting 3: User-Set Speed Agree 1 ( $f_{ref}/f_{set}$  Agree 1)**

Closes when the actual output frequency and the frequency reference are within the speed agree width (L4-02) of the programmed speed agree level (L4-01).

| Status | Description  |
|--------|--|
| Open   | Output frequency or motor speed and frequency reference are not both within the range of $L4-01 \pm L4-02$ . |
| Closed | Output frequency or motor speed and the frequency reference are both within the range of $L4-01 \pm L4-02$ . |

**Note:** Frequency detection works in forward and reverse. The value of L4-01 is used as the detection level for both directions.

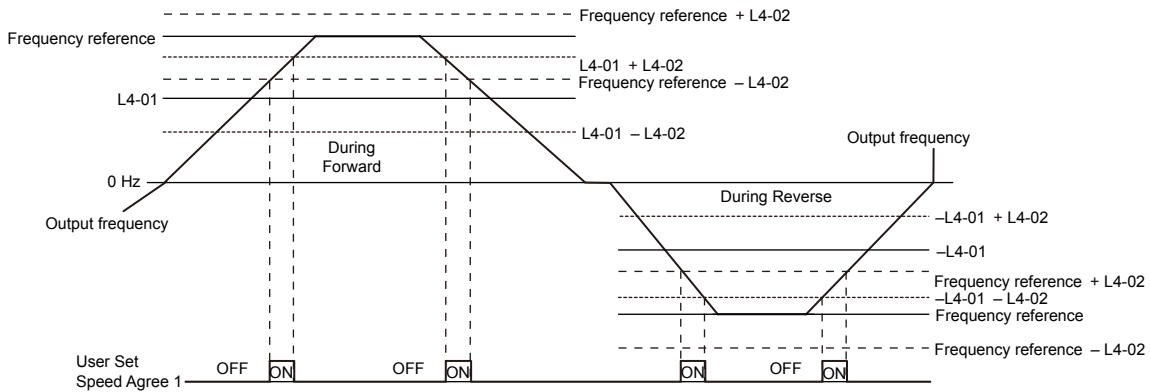


Figure 5.54 User Set Speed Agree 1 Time Chart

**Setting 4: Frequency Detection 1**

The output opens when the output frequency rises above the detection level set in L4-01 plus the detection width set in L4-02. The terminal remains open until the output frequency or motor speed fall below the level set in L4-01.

| Status | Description  |
|--------|--|
| Open   | Output frequency or motor speed exceeded $L4-01 + L4-02$ .                           |
| Closed | Output frequency or motor speed is below L4-01 or has not exceeded $L4-01 + L4-02$ . |

**Note:** Frequency detection works in forward and reverse. The value of L4-01 is used as the detection level for both directions.

## 5.7 H: Terminal Functions

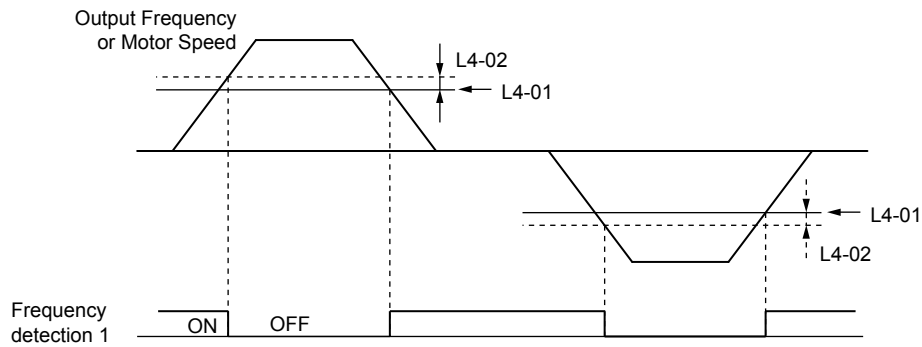


Figure 5.55 Frequency Detection 1 Time Chart

### Setting 5: Frequency Detection 2

The output closes when the output frequency is above the detection level set in L4-01. The terminal remains closed until the output frequency or motor speed fall below L4-01 minus the setting of L4-02.

| Status | Description   |
|--------|---|
| Open   | Output frequency or motor speed is below L4-01 minus L4-02 or has not exceeded L4-01. |
| Closed | Output frequency or motor speed exceeded L4-01.                                       |

**Note:** Frequency detection works in forward and reverse. The value of L4-01 is used as the detection level for both directions.

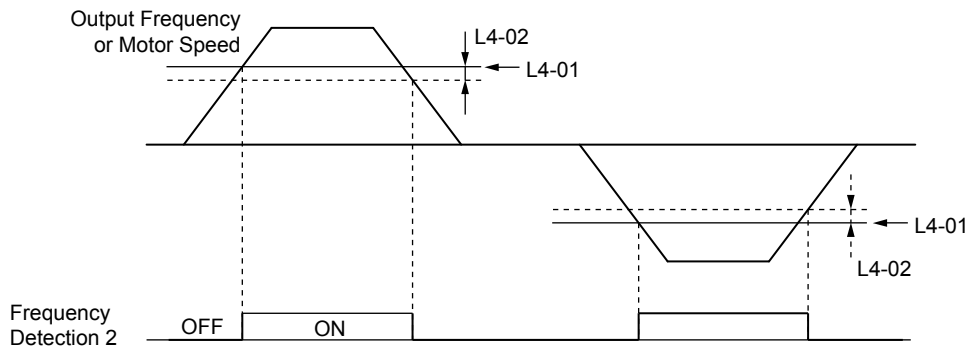


Figure 5.56 Frequency Detection 2 Time Chart

### Setting 6: Drive Ready

The output closes when the drive is ready to operate the motor. The terminal will not close under the conditions listed below, and all Run commands will be disregarded.

- When the power is shut off
- During a fault
- When the internal power supply of the drive has malfunctioned
- When a parameter setting error makes it impossible to run
- Although stopped, an overvoltage or undervoltage situation occurs
- While editing a parameter in the Programming Mode (when b1-08 = 0)

### Setting 7: DC Bus Undervoltage

The output closes when the DC bus voltage or control circuit power supply drops below the trip level set in L2-05. A fault in the DC bus circuit will also cause the terminal set for “DC bus undervoltage” to close.

| Status | Description  |
|--------|--|
| Open   | DC bus voltage is above the level set to L2-05.              |
| Closed | DC bus voltage has fallen below the trip level set to L2-05. |

### Setting 8: During Baseblock (N.O.)

The output closes to indicate that the drive is in a baseblock state. While in baseblock, output transistors do not switch and no main circuit voltage is output.



| Status | Description                        |
|--------|------------------------------------|
| Open   | Drive is not in a baseblock state. |
| Closed | Baseblock is being executed.       |

**Setting 9: Frequency Reference Source**

Displays the currently selected frequency reference source.

| Status | Description  |
|--------|--|
| Open   | Frequency reference is provided from External reference 1 (b1-01) or External reference 2 (b1-15). |
| Closed | Frequency reference is being sourced from the digital operator.                                    |

**Setting A: Run Command Source**

Displays the currently selected Run command source.

| Status | Description   |
|--------|---|
| Open   | Run command is provided from External reference 1 (b1-02) or 2 (b1-16). |
| Closed | Run command is being sourced from the digital operator.                 |

**Settings B, 17, 18, and 19: Torque Detection 1 (N.O., N.C.), Torque Detection 2 (N.O., N.C.)**

These digital output functions signal an overtorque or undertorque situation to an external device.

Set up the torque detection levels and select the output function from the table below.

| Setting | Status | Description   |
|---------|--------|---|
| B       | Closed | Torque detection 1 (N.O.):<br>Output current/torque exceeds (overtorque detection) or is below (undertorque detection) the torque value set in parameter L6-02 for longer than the time specified in parameter L6-03. |
| 17      | Open   | Torque detection 1 (N.C.):<br>Output current/torque exceeds (overtorque detection) or is below (undertorque detection) the torque value set in parameter L6-02 for longer than the time specified in parameter L6-03. |
| 18      | Closed | Torque detection 2 (N.O.):<br>Output current/torque exceeds (overtorque detection) or is below (undertorque detection) the torque value set in parameter L6-05 for longer than the time specified in parameter L6-06. |
| 19      | Open   | Torque detection 2 (N.C.):<br>Output current/torque exceeds (overtorque detection) or is below (undertorque detection) the torque value set in parameter L6-05 for longer than the time specified in parameter L6-06. |

**Setting C: Frequency Reference Loss**

An output set for this function closes when frequency reference loss is detected.

**Setting D: Braking Resistor Fault**

An output programmed for this function closes when the dynamic braking resistor (DB) overheats or the braking transistor is in a fault condition.

**Setting E: Fault**

The output closes when the drive faults (excluding CPF00 and CPF01 faults).

**Setting F: Through Mode**

Select this setting when using the terminal in a pass-through mode. When set to F, an output does not trigger any function in the drive. Setting F, however, still allows the status of the output terminal (open or closed) to be read by a PLC via a communication option or MEMOBUS/Modbus communications.

**Setting 10: Minor Fault (Alarm)**

The output closes when a minor fault (alarm) condition is present.

**Setting 11: Fault Reset Command Active**

The output closes when there is an attempt to reset a fault situation from the control circuit terminals, via serial communications, or using a communications option card.

**Setting 12: Timer Output**

This setting configures a digital output terminal as the output for the timer function.

## 5.7 H: Terminal Functions

### Setting 13: Speed Agree 2 ( $f_{ref} / f_{out}$ Agree 2)

The output closes when the actual output frequency is within the speed agree width (L4-04) of the current frequency reference, regardless of the direction.

| Status | Description  |
|--------|--|
| Open   | Output frequency or motor speed does not match the frequency reference while the drive is running. |
| Closed | Output frequency or motor speed is within the range of frequency reference $\pm L4-04$ .           |

**Note:** Detection works in forward and reverse.

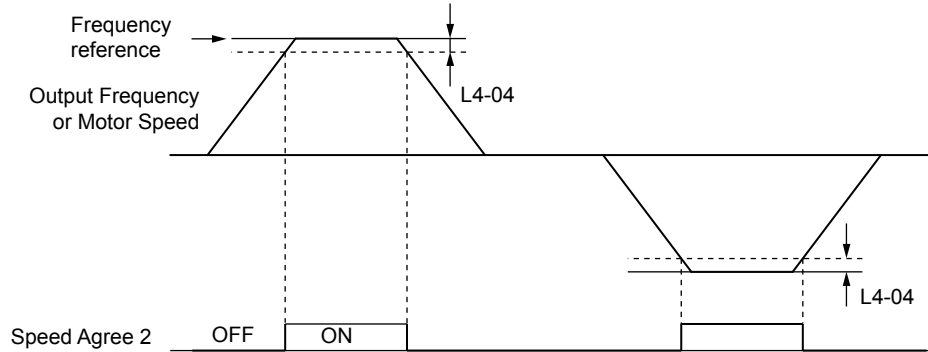


Figure 5.57 Speed Agree 2 Time Chart

### Setting 14: User-Set Speed Agree 2 ( $f_{ref} / f_{set}$ Agree 2)

The output closes when the actual output frequency and the frequency reference are within the speed agree width (L4-04) of the programmed speed agree level (L4-03).

| Status | Description  |
|--------|--|
| Open   | Output frequency or motor speed and frequency reference are both outside the range of $L4-03 \pm L4-04$ .    |
| Closed | Output frequency or motor speed and the frequency reference are both within the range of $L4-03 \pm L4-04$ . |

**Note:** The detection level L4-03 is a signed value; detection works in the specified direction only.

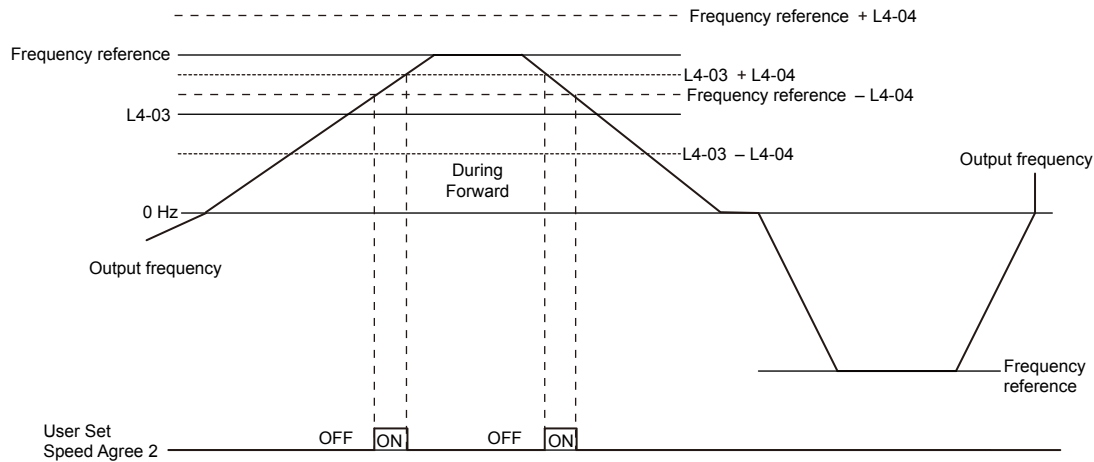


Figure 5.58 User-Set Speed Agree 2 Example with a Positive L3-04 Value

### Setting 15: Frequency Detection 3

The output opens when the output frequency rises above the detection level set in L4-03 plus the detection with set in L4-04. The terminal remains open until the output frequency or motor speed falls below the level set in L4-03. The detection level L4-03 is a signed value; detection works in the specified direction only.

| Status | Description   |
|--------|---|
| Open   | Output frequency or motor speed exceeded $L4-03$ plus $L4-04$ .                             |
| Closed | Output frequency or motor speed is below $L4-03$ or has not exceeded $L4-03$ plus $L4-04$ . |

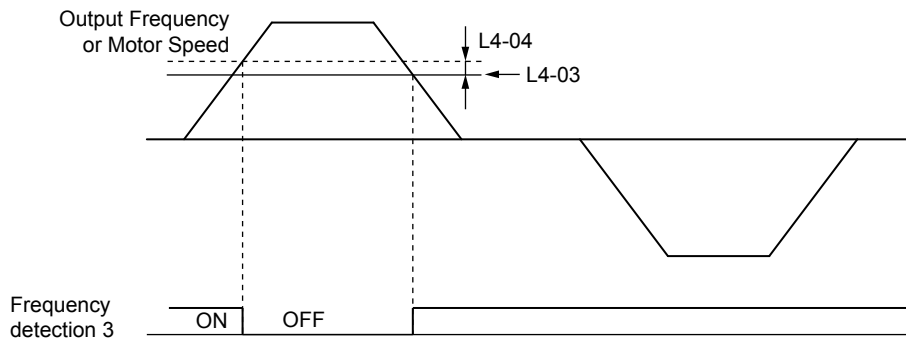


Figure 5.59 Frequency Detection 3 Example with a Positive L3-04 Value

**Setting 16: Frequency Detection 4**

The output closes when the output frequency is above the detection level set in L4-03. The terminal remains closed until the output frequency or motor speed falls below L4-03 minus the setting of L4-04.

| Status | Description   |
|--------|---|
| Open   | Output frequency or motor speed is below L4-03 minus L4-04 or has not exceeded L4-03. |
| Closed | Output frequency or motor speed exceeded L4-03.                                       |

**Note:** The detection level L4-03 is a signed value; detection works in the specified direction only.

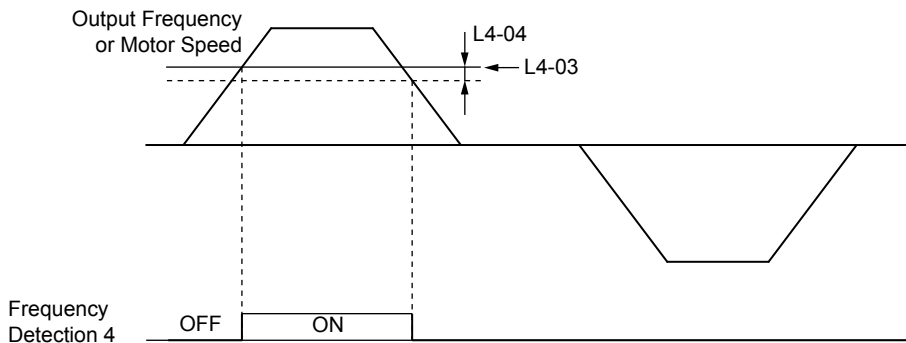


Figure 5.60 Frequency Detection 4 Example with Positive L3-04 Value

**Setting 1A: During Reverse**

A digital output set for “During reverse” closes when the drive is running the motor in the reverse direction.

| Status | Description  |
|--------|--|
| Open   | Motor is being driven in the forward direction or stopped. |
| Closed | Motor is being driven in reverse.                          |

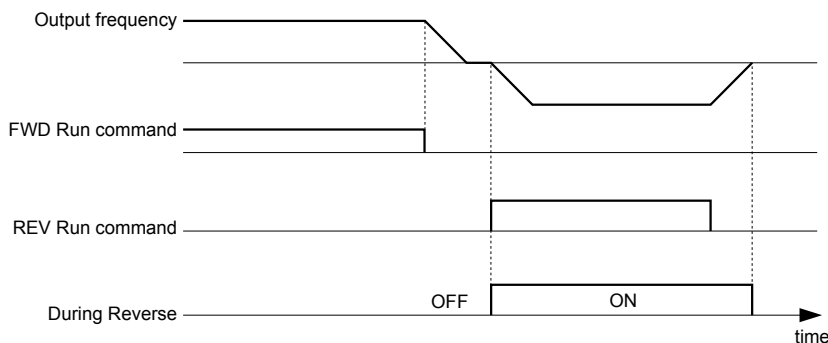


Figure 5.61 Reverse Direction Output Example Time Chart

## 5.7 H: Terminal Functions

### Setting 1B: During Baseblock (N.C.)

The output opens to indicate that the drive is in a baseblock state. While Baseblock is executed, output transistors do not operate and no main circuit voltage is output.

| Status | Description                        |
|--------|------------------------------------|
| Open   | Baseblock is being executed.       |
| Closed | Drive is not in a baseblock state. |

### Setting 1E: Restart Enabled

An output set for “Restart enabled” closes when the drive attempts to restart after a fault has occurred.

The fault restart function allows the drive to automatically clear a fault. The terminal set to 1E will close after the fault is cleared and the drive has attempted to restart. If the drive cannot successfully restart within the number of attempts permitted by L5-01, a fault will be triggered and the terminal set to 1E will open.

### Setting 1F: Motor Overload Alarm (oL1)

The output closes when the motor overload level estimated by the oL1 fault detection exceeds 90% of the oL1 detection level.

### Setting 20: Drive Overheat Pre-Alarm (oH)

The output closes when the drive heatsink temperature reaches the level specified by parameter L8-02.

### Setting 22: Mechanical Weakening Detection

The output closes when a mechanical weakening situation is detected.

### Setting 2F: Maintenance Period

The output closes when the cooling fan, DC bus capacitors, or DC bus pre-charge relay may require maintenance as determined by the estimated performance life span of those components. Components performance life is displayed as a percentage on the digital operator screen. [Refer to Performance Life Monitors Used for Component Replacement on page 292.](#)

### Setting 37: During Frequency Output

The output closes when the drive is outputting a frequency.

| Status | Description  |
|--------|--|
| Open   | Drive is stopped or one of the following functions is being performed: baseblock, DC Injection Braking, Short Circuit Braking. |
| Closed | Drive is outputting frequency.   |

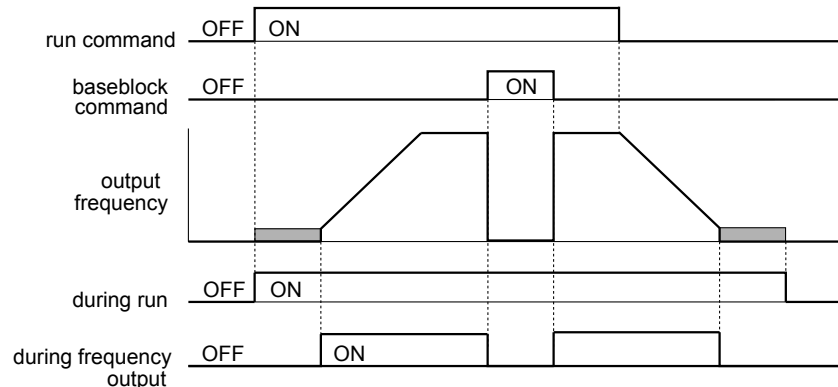


Figure 5.62 During Frequency Output Time Chart

### Setting 38: Drive Enable

Reflects the status of a digital input configured as a “Drive enable” input (H1-□□ = 6A). If that digital input closes, then the digital output set for “Drive enable” will also close.

### Setting 39: Watt Hour Pulse Output

Outputs a pulse to indicate the watt hours.

### Setting 3C: LOCAL/REMOTE Status

The output terminal closes while the drive is set for LOCAL and opens when in REMOTE.

| Status | Description  |
|--------|--|
| Open   | REMOTE: The external reference that has been selected (either b1-01 and b1-02 or b1-15 and b1-16) is used as frequency reference and Run command source. |
| Closed | LOCAL: The digital operator is used as frequency reference and Run command source.   |

**Setting 3D: During Speed Search**

The output terminal closes while Speed Search is being performed.

**Setting 3E: PID Feedback Low**

Output terminal closes when a PID feedback loss (FbL) is detected. The feedback is considered to be lost if it falls below the level set to b5-13 for longer than the time set to b5-14.

**Setting 3F: PID Feedback High**

Output terminal closes when a PID feedback loss (FbH) is detected. The feedback is considered to be lost if it rises beyond the level set to b5-36 for longer than the time set to b5-37.

**Setting 4A: During KEB Operation**

Output terminal closes while KEB is being performed.

**Setting 4C: During Fast Stop**

Output terminal closes when a Fast Stop is being executed.

**Setting 4D: oH Pre-Alarm Time Limit**

Output terminal closes when the drive is reducing the speed due to a drive overheat alarm (L8-03 = 4) and the overheat alarm has not disappeared after 10 frequency reduction operation cycles.

**Setting 4E: Braking Transistor Fault (rr)**

The output closes if the internal braking transistor reaches the overheat level.

**Setting 4F: Braking Resistor Overheat (rH)**

Output terminal closes when the braking resistor exceeds the overheat level. The braking resistor may overheat due to motor regeneration or short deceleration time setting.

**Setting 58: Underload Detection**

Output terminal closes when the output current falls below the underload detection level defined by L6-14 and L6-02.

**Setting 89: Output I Limit**

Output terminal closes when drive output speed is being limited due to the output current limit or the single-phase foldback regulator.

**Setting 8B: Lube Pump or Digital Output Delay**

Energizes for the time set in parameter P4-31 each time the drive is supposed to start. The drive will delay starting for the P4-31 time.

**Setting 8F: Internal Fan On**

Output terminal closes when the internal fan is active.

**Setting 91: Pump Fault**

Output terminal closes when any of the following faults are active: Low Feedback, High Feedback, Low Water, High Water, NMS-SetPoint Not Met, POC-Pump Over Cycle, THMS-Thermostat Input, External Pump Fault.

**Setting 92: Transducer Loss**

Output terminal closes the analog input associated with PID feedback has gone above 21mA or below 3mA, or a Transducer Loss Alarm or Fault is active.

**Setting 93: Setpoint Not Met**

Output terminal closes during an “NMS – SetPoint Not Met” condition.

**Setting 94: Loss of Prime**

Output terminal closes during an “LOP – Loss Of Prime” condition.

**Setting 95: Volute Thermostat Fault**

Output terminal closes when Volute-Thermostat digital input is active.

## 5.7 H: Terminal Functions

### Setting 96: High Feedback

Output terminal closes during a “High Feedback Condition” as defined by P1-11 and P1-14, or during a “High FB / Water” Fault, or during a “High Feedback” Alarm.

### Setting 97: Low Feedback

Output terminal closes during a “Low Feedback Condition” as defined by P1-08 and P1-14, or during a “Low FB/Water” Fault, or during a “Low Feedback” Alarm.

### Setting A2: Sleep Active

Output terminal closes when drive is not running due to the Sleep function (does not include Sleep Boost).

### Setting A3: Start Delay

Output terminal closes when feedback has risen above the start level (or fallen below the start level for Inverse PID) and the start timer is timing.

### Setting A4: Pre-Charge

Output terminal closes when the drive is in Pre-Charge mode.

### Setting A5: Anti-Jam Active

Detects and expels solids that are preventing the pump impeller from turning.

**WARNING! Sudden Movement Hazard.** The Anti-Jam function can force the motor to briefly run in the reverse direction and may cause injury even if parameter b1-04 is set to “Reverse Disabled”. Be sure all personnel are clear of rotating machinery.

### Setting A9: Thrust Mode

Output terminal closes when the Thrust Bearing feature is active (output frequency is between zero and P4-12).

### Setting AA: Utility Start Delay

Output terminal closes when the drive is stopped and waiting for the utility delay timer to expire. This setting is configured by P4-17.

### Settings 100 to 1AA: Functions 0 to AA with Inverse Output

These settings have the same function as settings 0 to AA but with inverse output. Set as 1□□, where the “1” indicates inverse output and the last two digits specify the setting number of the function.

Examples:

- For inverse output of “8: During baseblock”, set 108.
- For inverse output of “4A: During KEB” set 14A.

## ■ H2-06: Watt Hour Output Unit Selection

When one of the multi-function terminals is set to output the number of watt hours (H2-01/02/03 = 39), parameter H2-06 determines the units for the output signal.

The output is intended to drive a watt hour meter or a PLC input by a 200 ms pulse signal. A pulse is output according to the kWh unit selected in H2-06.

| No.   | Parameter Name                  | Setting Range  | Default |
|-------|---------------------------------|--|---------|
| H2-06 | Watt Hour Output Unit Selection | 0: 0.1 kWh units<br>1: 1 kWh units<br>2: 10 kWh units<br>3: 100 kWh units<br>4: 1000 kWh units | 0       |

## ■ H3-01: Terminal A1 Signal Level Selection

Selects the input signal level for analog input A1.

| No.   | Name                               | Setting Range | Default |
|-------|------------------------------------|---------------|---------|
| H3-01 | Terminal A1 Signal Level Selection | 0, 1          | 0       |

### Setting 0: 0 to 10 Vdc

The input level is 0 to 10 Vdc. The minimum input level is limited to 0%, so that a negative input signal due to gain and bias settings will be read as 0%.

**Setting 1: 0 to 10 Vdc Bipolar**

The input level is -10 to 10 Vdc. If the resulting voltage is negative after being adjusted by gain and bias settings, then the motor will rotate in reverse.

**■ H3-02: Terminal A1 Function Selection**

Selects the input signal level for analog input A1.

| No.   | Name                           | Setting Range | Default |
|-------|--------------------------------|---------------|---------|
| H3-02 | Terminal A1 Function Selection | 0 to 41       | 0       |

**■ H3-03, H3-04: Terminal A1 Gain and Bias Settings**

Parameter H3-03 sets the level of the selected input value that is equal to 10 Vdc input at terminal A1 (gain).

Parameter H3-04 sets the level of the selected input value that is equal to 0 V input at terminal A1 (bias).

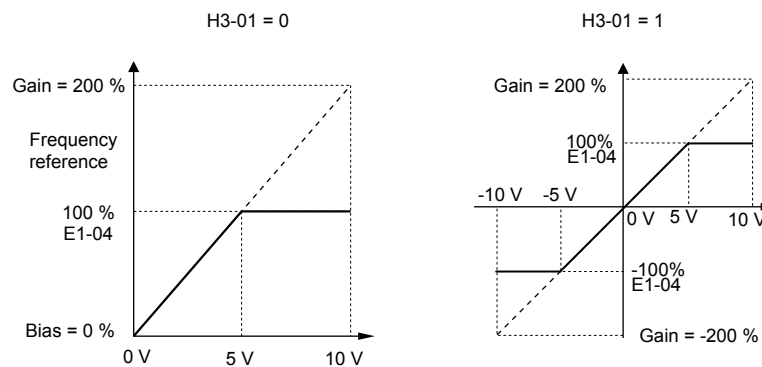
Use both parameters to adjust the characteristics of the analog input signal to terminal A1.

| No.   | Name                     | Setting Range    | Default |
|-------|--------------------------|------------------|---------|
| H3-03 | Terminal A1 Gain Setting | -999.9 to 999.9% | 100.0%  |
| H3-04 | Terminal A1 Bias Setting | -999.9 to 999.9% | 0.0%    |

**Setting Examples**

- Gain H3-03 = 200%, bias H3-04 = 0, terminal A1 as frequency reference input (H3-02 = 0):

A 10 Vdc input is equivalent to a 200% frequency reference and 5 Vdc is equivalent to a 100% frequency reference. Since the drive output is limited by the maximum frequency parameter (E1-04), the frequency reference will be equal to E1-04 above 5 Vdc.



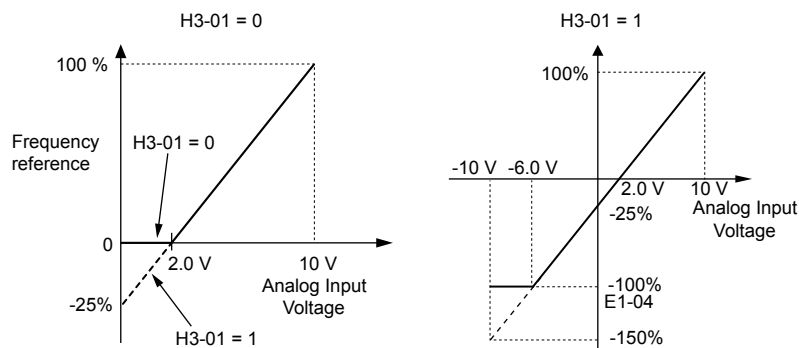
**Figure 5.63 Frequency Reference Setting by Analog Input with Increased Gain**

- Gain H3-03 = 100%, bias H3-04 = -25%, terminal A1 as frequency reference input:

An input of 0 Vdc will be equivalent to a -25% frequency reference.

When parameter H3-01 = 0, the frequency reference is 0% between 0 and 2 Vdc input.

When parameter H3-01 = 1, the motor will rotate in reverse between -10 and 2 Vdc input.



**Figure 5.64 Frequency Reference Setting by Analog Input with Negative Bias**

## 5.7 H: Terminal Functions

### ■ H3-09: Terminal A2 Signal Level Selection

Selects the input signal level for analog input A2. Set DIP Switch S1-2 on the terminal board accordingly for a voltage input or current input.

| No.   | Name                               | Setting Range | Default |
|-------|------------------------------------|---------------|---------|
| H3-09 | Terminal A2 Signal Level Selection | 0 to 3        | 2       |

#### Setting 0: 0 to 10 Vdc

The input level is 0 to 10 Vdc. *Refer to Setting 0: 0 to 10 Vdc on page 182.*

#### Setting 1: 0 to 10 Vdc Bipolar

The input level is -10 to 10 Vdc. *Refer to Setting 1: 0 to 10 Vdc Bipolar on page 183.*

#### Setting 2: 4 to 20 mA

The input level is 4 to 20 mA. Negative input values by negative bias or gain settings will be limited to 0%.

#### Setting 3: 0 to 20 mA

The input level is 0 to 20 mA. Negative input values by negative bias or gain settings will be limited to 0%.

### ■ H3-10: Terminal A2 Function Selection

Determines the function assigned to analog input terminal A2.

| No.   | Name                           | Setting Range | Default |
|-------|--------------------------------|---------------|---------|
| H3-10 | Terminal A2 Function Selection | 0 to 32       | B       |

### ■ H3-11, H3-12: Terminal A2 Gain and Bias Setting

Parameter H3-11 sets the level of the input value selected that is equal to 10 Vdc input or 20 mA input to terminal A2.

Parameter H3-12 sets the level of the input value selected that is equal to 0 V, 4 mA or 0 mA input at terminal A2.

Use both parameters to adjust the characteristics of the analog input signal to terminal A2. The setting works in the same way as parameters H3-03 and H3-04 for analog input A1.

| No.   | Name                     | Setting Range    | Default |
|-------|--------------------------|------------------|---------|
| H3-11 | Terminal A2 Gain Setting | -999.9 to 999.9% | 100.0%  |
| H3-12 | Terminal A2 Bias Setting | -999.9 to 999.9% | 0.0%    |

### ■ H3-13: Analog Input Filter Time Constant

Parameter H3-13 sets the time constant for a first order filter that will be applied to both analog inputs A1 and A2.

| No.   | Name                              | Setting Range  | Default |
|-------|-----------------------------------|----------------|---------|
| H3-13 | Analog Input Filter Time Constant | 0.00 to 2.00 s | 0.03 s  |

An analog input filter can be used to prevent erratic drive control when a “noisy” analog reference is used. The drive operation becomes more stable the longer the time programmed, but it becomes less responsive to rapidly changing analog signals.

### ■ Multi-Function Analog Input Terminal Settings for A1 and A2 (H3-02 and H3-10)

This section describes the various functions that can be assigned to terminals A1 and A2 by setting H3-02 and H3-10.

**Note:** The scaling of all input functions depends on the gain and bias settings for the analog inputs. Set these to appropriate values when selecting and adjusting analog input functions.

Table 5.25 Multi-Function Input Terminal Settings

| Setting | Function                               | Page                | Setting | Function                      | Page                |
|---------|--|---------------------|---------|-------------------------------|---------------------|
| 0       | Frequency Bias                         | <a href="#">185</a> | E       | Motor Temperature (PTC input) | <a href="#">185</a> |
| 1       | Frequency Gain                         | <a href="#">185</a> | F       | Not Used                      | <a href="#">185</a> |
| 2       | Auxiliary Frequency Reference          | <a href="#">185</a> | 16      | Differential PID Feedback     | <a href="#">185</a> |
| 4       | Output Voltage Bias                    | <a href="#">185</a> | 1F      | Not Used                      | <a href="#">185</a> |
| 7       | Overtorque/Undertorque Detection Level | <a href="#">185</a> | 20      | HAND Frequency Reference      | <a href="#">185</a> |
| B       | PID Feedback                           | <a href="#">185</a> | 41      | Output Voltage Gain           | <a href="#">185</a> |
| C       | PID Setpoint                           | <a href="#">185</a> |         |                               |                     |



**Setting 0: Frequency Bias**

The input value of an analog input set to this function will be added to the analog frequency reference value. Use this setting also when only one analog input is used to supply the frequency reference.

By default both analog inputs A1 and A2 are set for this function. Using both A1 and A2 at the same time increases the frequency reference by the total of both inputs.

Example: If the analog frequency reference by analog input A1 is 50% and a bias of 20% is applied by analog input A2, the resulting frequency reference will be 70% of the maximum output frequency.

**Setting 1: Frequency Gain**

The input value of an analog input set to this function will be multiplied with the analog frequency reference value.

Example: If the analog frequency reference from analog input A1 is 80% and a gain of 50% is applied from analog input A2, the resulting frequency reference will be 40% of the maximum output frequency.

**Setting 2: Auxiliary Reference**

Sets the auxiliary frequency reference when Multi-Step Speed operation is selected. *Refer to Multi-Step Speed Selection on page 147* for details.

**Setting 4: Voltage Bias**

Voltage bias boosts the output voltage of the V/f curve as a percentage of the maximum output voltage (E1-05). Available only when using V/f Control.

**Setting 7: Overtorque/Undertorque Level**

Overtorque level sets the overtorque/undertorque detection level using the analog input. This works with Torque Detection Selection 1 (L6-01) and will take the place of the torque detection level set to L6-02. For V/f Control, this function is based on 100% of the drive rated current. *Refer to L6: Torque Detection on page 205* for details on torque detection.

**Setting B: PID Feedback**

An input set for this function supplies the PID feedback value. This setting requires PID operation to be enabled in b5-01. *Refer to PID Feedback Input Methods on page 131.*

**Setting C: PID Setpoint**

An input set for this function supplies the PID setpoint value. The frequency reference selected in parameter b1-01 no longer becomes the PID setpoint. This setting requires PID operation to be enabled in b5-01. *Refer to PID Setpoint Input Methods on page 131.*

**Setting E: Motor Temperature**

In addition to or in place of the oL1 (motor overload) fault detection, it is possible to use a PTC (Positive Temperature Coefficient) thermistor for motor insulation protection. *Refer to Motor Protection Using a Positive Temperature Coefficient (PTC) on page 191* for detailed explanations.

**Setting F: Not Used**

Any analog input that is not used should be set to F. When set to "F", an input does not affect any drive function but the input level can be read out by a PLC via a communication option or MEMOBUS/Modbus communications (through mode). This way drive analog inputs can be used to read out external sensor values if there is a lack of PLC analog inputs.

**Setting 16: Differential PID Feedback**

If an analog value is set for this function, the PID controller is set for differential feedback. The subtraction of the PID feedback input value and the differential feedback input value builds the feedback value that is used to calculate the PID input. *Refer to PID Feedback Input Methods on page 131.*

**Setting 1F: Not Used**

An input does not affect any drive function, but the input level can still be read out by a PLC via a communication option or MEMOBUS/Modbus communications.

**Setting 20: HAND Frequency Reference**

Provides the HAND frequency reference when HAND Mode Frequency Reference Source parameter P5-01 is set to 1.

**Setting 41: Output Voltage Gain**

Allows the user to change the output voltage by adjusting the voltage reference via one of the analog input terminals or with MEMOBUS/Modbus.

## 5.7 H: Terminal Functions

An internal 0.3 second delay has been added to prevent sudden, drastic change to the V/f pattern.

**Note:** When an input terminal is assigned to adjust the Output Voltage Gain (H3-□□ = 41), a voltage reference from MEMOBUS/Modbus is ignored.

### ■ H3-14: Analog Input Terminal Enable Selection

Determines which of the analog input terminals will be enabled or disabled when a digital input programmed for “Analog input enable” (H1-□□ = C) is closed. When H1-□□ ≠ C, all of the input terminals are enabled all of the time. Terminals not set as the target are not influenced by input signals.

| No.   | Name                                   | Setting Range | Default |
|-------|--|---------------|---------|
| H3-14 | Analog Input Terminal Enable Selection | 1, 2, 7       | 7       |

**Setting 1: Terminal A1 only**

**Setting 2: Terminal A2 only**

**Setting 7: All Terminals Enabled**

### ■ H3-16/H3-17: Terminal A1/A2 Offset

Determines the amount of offset to be used to calibrate analog input signals from the terminals A1 and A2.

Enter a 0 V signal to terminal A1. Next adjust the offset in H3-16 until the monitor U1-13 for the terminal A1 input voltage reads 0.0%.

The process is the same for terminal A2. Enter a 0 V signal, and adjust the offset for terminal A2 in H3-17 until the monitor U1-14 for terminal A2 input voltage reads 0.0%.

| No.   | Name               | Setting Range | Default |
|-------|--------------------|---------------|---------|
| H3-16 | Terminal A1 Offset | -500 to 500   | 0       |
| H3-17 | Terminal A2 Offset | -500 to 500   | 0       |

## ◆ H4: Multi-Function Analog Output Terminals

These parameters assign a function to analog output terminal AM for monitoring a specific aspect of drive performance.

### ■ H4-01: Multi-Function Analog Terminal AM Monitor Selection

Sets the desired drive monitor parameter U□-□□ to output as an analog value via terminal AM. *Refer to U: Monitors on page 369* for a list of all monitors. The “Analog Output Level” columns indicates if a monitor can be applied for analog output.

Example: Enter “103” for U1-03.

| No.   | Name  | Setting Range | Default |
|-------|---|---------------|---------|
| H4-01 | Multi-Function Analog 1 (Terminal AM Monitor Selection) | 000 to 999    | 102     |

A setting of 031 or 000 applies no drive monitor to the analog output. With this setting the terminal AM output level can be set by a PLC via a communication option or MEMOBUS/Modbus communications (through mode).

### ■ H4-02/H4-03: Multi-Function Analog Output Terminal AM Gain/Bias

Parameter H4-02 sets the output voltage that is equal to 100% of the monitor value. Parameter H4-03 sets the output voltage equal to 0% of the monitor value.

Both values are set as a percentage of 10 V. The minimum output voltage for terminal AM is 0 V, the maximum is 10 Vdc. *Figure 5.65* illustrates the function of the gain and bias settings.

| No.   | Name  | Setting Range    | Default |
|-------|---|------------------|---------|
| H4-02 | Multi-Function Analog Output Terminal AM Gain | -999.9 to 999.9% | 100.0%  |
| H4-03 | Multi-Function Analog Output Terminal AM Bias | -999.9 to 999.9% | 0.0%    |

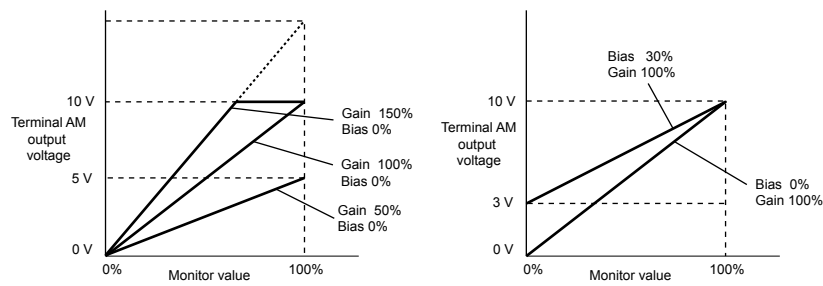


Figure 5.65 Analog Output Gain/Bias Setting

When viewing the settings for H4-02, terminal AM will output a voltage that is equal to 100% of the monitor value (considering the present setting). When viewing the settings for H4-03, terminal AM will output a voltage that is equal to 0% of the monitor value.

## ◆ H6: Pulse Train Input/Output

A one track pulse train signal with a maximum frequency of 32 kHz can be input to the drive at terminal RP. This pulse train signal can be used as the frequency reference, for PID functions, or as the speed feedback signal in V/f Control.

The pulse output monitor terminal MP, which can be used in sinking or sourcing mode, can output drive monitor values as a pulse train signal with a maximum frequency of 32 kHz.

Use parameters H6-□□ to scale and set up the function for the pulse input terminal RP and pulse output terminal MP.

### ■ H6-01: Pulse Train Input Terminal RP Function Selection

Selects the function of pulse train input terminal RP.

| No.   | Name   | Setting Range | Default |
|-------|--|---------------|---------|
| H6-01 | Pulse Train Input Terminal RP Function Selection | 0 to 4        | 0       |

#### Setting 0: Frequency Reference

If the pulse input is set for this function and the frequency reference source is set to pulse input (b1-01/15 = 4), the drive reads the frequency value from terminal RP.

#### Setting 1: PID Feedback Value

Using this setting, the feedback value for PID control can be supplied as a pulse signal at terminal RP. *Refer to b5: PID Control on page 129* for details on PID control.

#### Setting 2: PID Setpoint Value

Using this setting, the setpoint value for PID control can be supplied as a pulse signal at terminal RP. *Refer to b5: PID Control on page 129* for details on PID control.

#### Setting 3: Speed Feedback for V/f Control (V/f Control only, Motor 1 only)

This setting enables simple speed feedback for V/f Control. A pulse signal can be used to input the motor speed to the drive and thereby improve the speed control accuracy. Note that this speed feedback can only be a one track signal that cannot be used for direction detection. The drive needs a separate motor rotation direction signal.

### ■ H6-02: Pulse Train Input Terminal RP Scaling

The pulse train input scaling parameter sets the terminal RP input frequency that is equal to 100% of the signal selected as the input value in parameter H6-01.

| No.   | Name                      | Setting Range   | Default |
|-------|---------------------------|-----------------|---------|
| H6-02 | Pulse Train Input Scaling | 100 to 32000 Hz | 1440 Hz |

### ■ H6-03: Pulse Train Input Terminal RP Gain

Sets the level of the value selected in H6-01 when a pulse train signal with the frequency set in H6-02 is input to terminal RP.

| No.   | Name                   | Setting Range  | Default |
|-------|------------------------|----------------|---------|
| H6-03 | Pulse Train Input Gain | 0.0 to 1000.0% | 100.0%  |

## 5.7 H: Terminal Functions

### ■ H6-04: Pulse Train Input Terminal RP Bias

Sets the level of the value selected in H6-01 when a 0 Hz signal is input to terminal RP.

| No.   | Name                   | Setting Range    | Default |
|-------|------------------------|------------------|---------|
| H6-04 | Pulse Train Input Bias | -100.0 to 100.0% | 0.0%    |

### ■ H6-05: Pulse Train Input Terminal RP Filter Time

Sets the pulse train input filter time constant in seconds.

The pulse train input filter helps prevent noise interference from causing erroneous operation when operating the drive within the pulse train signal.

Increasing the filter setting time increases the effectiveness of the noise prevention, however, this also increasingly slows drive response time.

| No.   | Name                          | Setting Range  | Default |
|-------|-------------------------------|----------------|---------|
| H6-05 | Pulse Train Input Filter Time | 0.00 to 2.00 s | 0.10 s  |

### ■ H6-06: Pulse Train Output Terminal MP Monitor Selection

Selects the pulse train monitor output terminal MP function. The set value  $\square\square\square$  is equal to the numerals in  $U\square-\square\square$  of the selected monitor. *Refer to U: Monitors on page 369* for a complete list of monitors. Selectable monitor items are listed below.

| No.   | Name   | Setting Range                                      | Default |
|-------|--|--|---------|
| H6-06 | Pulse Train Output Terminal MP Monitor Selection | 000, 031, 101, 102, 105, 116, 501, 502, 801 to 809 | 102     |

### ■ H6-07: Pulse Train Output Terminal MP Monitor Scaling

Pulse train monitor scaling sets the output frequency at terminal MP when the monitor item is 100%. Set H6-06 to 102 and H6-07 to 0 to make the pulse train monitor output synchronous to the output frequency.

| No.   | Name                              | Setting Range | Default |
|-------|-----------------------------------|---------------|---------|
| H6-07 | Pulse Train Input Monitor Scaling | 0 to 32000 Hz | 1440 Hz |

### ■ H6-08: Pulse Train Input Minimum Frequency

Sets the minimum output frequency detected by the pulse train input. Increasing this setting reduces the time the drive needs to react to changes in the input signal.

- The pulse input value becomes 0 when the pulse input frequency falls below this level.
- Enabled when H6-01 = 0, 1, or 2.
- When simple speed feedback in V/f Control is set as the function for terminal RP (H6-01 = 3), the minimum frequency becomes the detection time for PG disconnect (F1-14).

| No.   | Name                                | Setting Range    | Default |
|-------|-------------------------------------|------------------|---------|
| H6-08 | Pulse Train Input Minimum Frequency | 0.1 to 1000.0 Hz | 0.5 Hz  |

## 5.8 L: Protection Functions

### ◆ L1: Motor Protection Functions

#### ■ L1-01: Motor Overload Protection Selection

The drive has an electronic overload protection function that estimates the motor overload level based on output current, output frequency, thermal motor characteristics, and time. An oL1 fault will be triggered when motor overload is detected.

L1-01 sets the overload protection function characteristics according to the motor being used.

| No.   | Name                                | Setting Range | Default |
|-------|-------------------------------------|---------------|---------|
| L1-01 | Motor Overload Protection Selection | 0 to 3; 6     | 1       |

- Note:**
1. When the motor protection function is enabled (L1-01 is not set to zero), an oL1 alarm can be output through one of the multi-function outputs by setting H2-01 to 1F. The output will close when the motor overload level reaches 90% of the oL1 detection level.
  2. Select a method to protect the motor from overheat by setting L1-01 to a value between 1 and 3; use setting 6 when running a single motor from the drive. An external thermal relay is not required.

#### Setting 0: Disabled - Motor Overload Protection is not Provided

This setting should be used if no motor overheat protection is desired or if multiple motors are connected to one drive. In this case it is recommended that you install a thermal relay for each motor as show in [Figure 5.66](#)

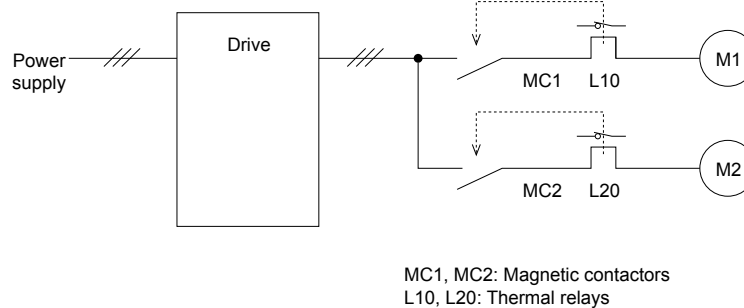


Figure 5.66 Example of Protection Circuit Design for Multiple Motors

**NOTICE:** Protect each motor with individual thermal overloads when multiple motors are connected to one drive. Failure to comply could result in motor damage. Disable the electronic overload protection of the drive (L1-01 = "0: Disabled") and protect each motor with individual motor thermal overloads.

#### Setting 1: General Purpose Motor (standard self-cooled)

Because the motor is self-cooled, the overload tolerance drops when the motor speed is lowered. The drive appropriately adjusts the electrothermal trigger point according to the motor overload characteristics, protecting the motor from overheat throughout the entire speed range.

| Overload Tolerance   | Cooling Ability  | Overload Characteristics  |
|--|--|---|
| <p>Torque (%)</p> <p>150<br/>100<br/>90<br/>60<br/>50</p> <p>60 sec.</p> <p>Rated Speed=100% Speed</p> <p>Continuous</p> <p>A B C</p> <p>05 33 100 120 167 200<br/>(60 Hz)<br/>Speed (%)</p> | <p>Motor designed to operate from line power.<br/>Motor cooling is most effective when running at rated nameplate base frequency (check the motor specifications).</p> | <p>Continuous operation at less than line power frequency with 100% load can trigger motor overload protection (oL1). A fault is output and the motor will coast to stop.</p> |

#### Setting 2: Drive Dedicated Motor (constant torque, 1:10)

Use this setting when operating a drive duty motor with a torque ratio of 1:10. This motor type is allowed to run with 100% load from 10% up to 100% speed. Running slower speeds with full load can trigger an overload fault.

## 5.8 L: Protection Functions

| Overload Tolerance | Cooling Ability   | Overload Characteristics  |
|--------------------|---|---|
|                    | <p>Motor is designed to effectively cool itself at speeds as low as 6 Hz.</p> | <p>Continuous operation with 100% load from 6 Hz to 50/60 Hz.</p> |

### Setting 3: Vector Motor (constant torque, 1:100)

Use this setting when operating a drive dedicated motor with a torque ratio of 1:100. This motor type is allowed to run with 100% load from 1% up to 100% speed. Running slower speeds with full load can trigger an overload fault.

| Overload Tolerance | Cooling Ability   | Overload Characteristics  |
|--------------------|---|---|
|                    | <p>Motor is designed to effectively cool itself at speeds as low as approximately 0.6 Hz.</p> | <p>Continuous operation with 100% load from 0.6 Hz to 50/60 Hz.</p> |

### Setting 6: General-Purpose Motor

**Note:** General-purpose motors are designed with a base speed that operates at line frequency (50/60 Hz depending on geographic region).

Because the motor is self-cooled, the overload tolerance drops when the motor speed is lowered. The drive appropriately adjusts the electrothermal trigger point according to the motor overload characteristics and protects the motor from overheat throughout the entire speed range.

| Overload Tolerance | Cooling Ability  | Overload Characteristics  |
|--------------------|--|---|
|                    | <p>Motor designed to operate from line power. Motor cooling is most effective when running at rated base frequency (check the motor nameplate or specifications)</p> | <p>Continuous operation at less than line power frequency with 100% load can trigger motor overload protection (oL1). A fault is output and the motor will coast to stop.</p> |

### ■ L1-02: Motor Overload Protection Time

Sets the time for the drive to shut down on motor overload (oL1) when the motor is running with excessive current. Enter the time the motor can withstand operating at 150% current after previously running at 100% current (hot motor overload condition). This parameter rarely requires adjustment.

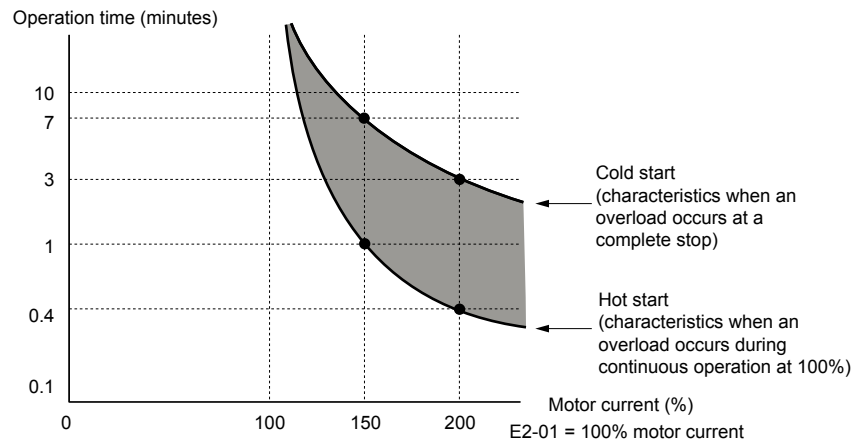
| No.   | Name                           | Setting Range      | Default     |
|-------|--------------------------------|--------------------|-------------|
| L1-02 | Motor Overload Protection Time | 0.1 to 5.0 minutes | 1.0 minutes |

Defaulted to operate with an allowance of 150% overload operation for one minute in a hot start after continuous operation at 100%.

**Figure 5.67** illustrates an example of the electrothermal protection operation time using a general-purpose motor operating at the value of E1-06, Motor Base Speed, with L1-02 set to one minute.

Motor overload protection operates in the area between a cold start and a hot start.

- Cold start: Characteristics of motor protection operation time in response to an overload situation that was suddenly reached when starting a stationary motor.
- Hot start: Characteristics of motor protection operation time in response to an overload situation that occurred while the motor was operating continuously at or below its rated current.

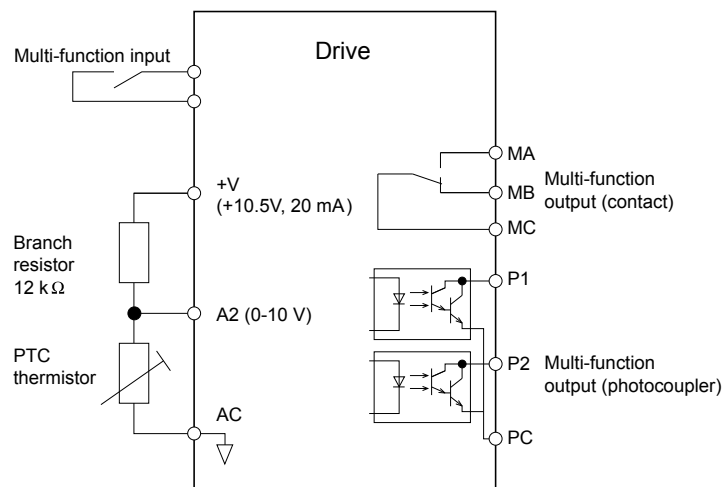


**Figure 5.67** Protection Operation Time for General Purpose Motors at the Rated Output Frequency

### ■ Motor Protection Using a Positive Temperature Coefficient (PTC)

A motor PTC can be connected to an analog input of the drive. This input is used by the drive for motor overheat protection. When the motor overheat alarm level is reached, an oH3 alarm will be triggered and the drive will continue operation as selected in L1-03. When the overheat fault level is reached an oH4 fault is triggered, a fault signal will be output and the drive will stop the motor using the stop method determined in L1-04.

**Figure 5.68** shows a PTC connection example for analog input A2. If using analog input A2, make sure to set DIP switch S1 on the terminal board for voltage input when using this function.



**Figure 5.68** Connection of a Motor PTC

The PTC must have the following characteristics for one motor phase. Normally a motor is protected by three PTCs connected in series.

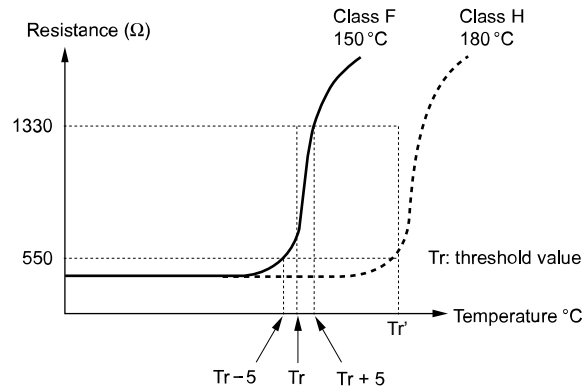


Figure 5.69 Motor PTC Characteristics

Overheat detection using a PTC can be set up by parameters L1-03/04/05 as explained below.

### ■ L1-03: Motor Overheat Alarm (oH3) Operation Selection

Sets the drive operation when the PTC input signal reaches the motor overheat alarm level. (PTC input level:  $Tr - 5$  °C)

| No.   | Name                                     | Setting Range | Default |
|-------|--|---------------|---------|
| L1-03 | Motor Overheat Alarm Operation Selection | 0 to 3        | 3       |

#### Setting 0: Ramp to Stop

The drive stops the motor using the active deceleration time.

#### Setting 1: Coast to Stop

The drive output is switched off and the motor coasts to stop.

#### Setting 2: Fast-stop

The drive stops the motor using the Fast-stop time set in parameter C1-09.

#### Setting 3: Alarm Only

The operation is continued and an oH3 alarm is displayed on the digital operator



### ■ L1-04: Motor Overheat Fault (oH4) Operation Selection

Sets the drive operation when the PTC input signal reaches the motor overheat fault level. (PTC input level: Tr + 5 °C)

| No.   | Name                                     | Setting Range | Default |
|-------|--|---------------|---------|
| L1-04 | Motor Overheat Fault Operation Selection | 0 to 2        | 1       |

#### Setting 0: Ramp to Stop

The drive stops the motor using the active deceleration time.

#### Setting 1: Coast to Stop

The drive output is switched off and the motor coasts to stop.

#### Setting 2: Fast-stop

The drive stops the motor using the Fast-stop time set in parameter C1-09.

### ■ L1-05: Motor Temperature Input Filter Time

Used to set a filter on the PTC signal in order to prevent a motor overheat fault from being mistakenly detected.

| No.   | Name                                | Setting Range   | Default |
|-------|-------------------------------------|-----------------|---------|
| L1-05 | Motor Temperature Input Filter Time | 0.00 to 10.00 s | 0.20 s  |

### ■ L1-13: Continuous Electrothermal Operation Selection

Determines whether to hold the current value of the electrothermal motor protection (L1-01) when the power supply is interrupted.

| No.   | Name  | Setting Range | Default |
|-------|---|---------------|---------|
| L1-13 | Continuous Electrothermal Operation Selection | 0 or 1        | 1       |

#### Setting 0: Disabled

#### Setting 1: Enabled

### ■ L1-22: Leakage Current Filter Time Constant 1

**Note:** Available only when C6-02 is set to B. To display this parameter, first set C6-02 to B.

Sets the time constant for the filter applied to motor overload detection current or monitor current for constant speed operation. Leakage current can incorrectly trigger motor overload fault oL1 or result in incorrect monitor reading. Increase this setting if erroneous detection occurs or if the monitor display is incorrect.

**NOTICE:** Setting parameter L1-22 too high may cause the drive to detect motor overload too slowly and burn out the motor. Be sure to set L1-22 to an appropriate value for the application.

| No.   | Name                                   | Setting Range | Default |
|-------|--|---------------|---------|
| L1-22 | Leakage Current Filter Time Constant 1 | 0.0 to 60.0 s | 20.0 s  |

### ■ L1-23: Leakage Current Filter Time Constant 2

**Note:** Available only when C6-02 is set to B. To display this parameter, first set C6-02 to B.

Sets the time constant for the filter applied to monitor current during acceleration and deceleration. Leakage current can result in incorrect monitor reading. Increase this setting if the monitor display is incorrect.

**Note:** Setting parameter L1-23 too high may cause the current monitor to take too long to read the initial current level. Check the operation sequence being used if this is a problem.

| No.   | Name                                   | Setting Range | Default |
|-------|--|---------------|---------|
| L1-23 | Leakage Current Filter Time Constant 2 | 0.0 to 60.0 s | 1.0 s   |

## ◆ L2: Momentary Power Loss Ride-Thru

### ■ L2-01: Momentary Power Loss Operation Selection

When a momentary power loss occurs (DC bus voltage falls below the level set in L2-05), the drive can be set to automatically return to the operation it was performing when the power went out based on certain conditions.

## 5.8 L: Protection Functions

| No.   | Name                                     | Setting Range | Default |
|-------|--|---------------|---------|
| L2-01 | Momentary Power Loss Operation Selection | 0 to 2        | 0       |

### Setting 0: Disabled (default)

If power is not restored within 15 ms, a Uv1 fault will result and the drive will stop the motor.

### Setting 1: Enabled, Recover Within L2-02

When a momentary power loss occurs, the drive will attempt to restart and perform Speed Search if power is restored within the period of time set to parameter L2-02. If power is not restored within the time set to L2-02 (i.e. DC bus voltage level remains below Uv1 detection level L2-05), then a Uv1 fault is triggered and the drive output will be shut off.

### Setting 2: Recover as Long as CPU has Power

Drive will try to restart as long as the CPU still has power. This allows for a longer ride-through time than setting L2-01 to 1. A Uv1 fault is not triggered. This setting should also be used if the KEB function is utilized.

- Note:**
1. The amount of time the drive is capable of recovering after a power loss is determined by the capacity of the drive. Drive capacity determines the upper limit for L2-02.
  2. When L2-01 is set to 1 or 2, and a magnetic contactor between motor and drive is used, be sure that the magnetic contactor is kept close as long as the drive attempts to restart.
  3. When L2-01 is set to 1 or 2, "Uv" will flash on the operator while the drive is attempting to recover from a momentary power loss. A fault signal is not output at this time.

## ■ L2-02: Momentary Power Loss Ride-Thru Time

Set the time in which the power has to return before a Uv fault is tripped. This parameter is valid only if L2-01 = 1.

| No.   | Name                                | Setting Range | Default              |
|-------|-------------------------------------|---------------|----------------------|
| L2-02 | Momentary Power Loss Ride-Thru Time | 0.0 to 25.5 s | Determined by o2-04. |

## ■ L2-03: Momentary Power Loss Minimum Baseblock Time

Sets the minimum baseblock time when power is restored following a momentary power loss. This determines the time it takes for the leftover voltage in the motor to dissipate. Increase this setting if overcurrent or overvoltage occur at the beginning of Speed Search after a power loss or DC Injection Braking. If L2-03 > L2-02, then the drive will restart after the time set to L2-03 has passed from the beginning of the power loss.

| No.   | Name  | Setting Range | Default             |
|-------|---|---------------|---------------------|
| L2-03 | Momentary Power Loss Minimum Baseblock Time | 0.1 to 5.0 s  | Determined by o2-04 |

## ■ L2-04: Momentary Power Loss Voltage Recovery Ramp Time

Sets the time constant used to ramp up the voltage during Speed Search. The setting value determines the time for a change from zero to the maximum voltage.

| No.   | Name  | Setting Range | Default             |
|-------|---|---------------|---------------------|
| L2-04 | Momentary Power Loss Voltage Recovery Ramp Time | 0.0 to 5.0 s  | Determined by o2-04 |

## ■ L2-05: Undervoltage Detection Level

Determines the voltage at which a Uv1 fault is triggered or at which the KEB function is activated.

| No.       | Name                         | Setting Range | Default   |
|-----------|------------------------------|---------------|-----------|
| L2-05 <1> | Undervoltage Detection Level | 150 to 210 V  | 190 V <2> |

<1> Values are for 200 V class drives and must be doubled for 400 V class drives.

<2> This value is initialized when E1-01 is changed.

This setting rarely needs to be changed.

When setting L2-05 is lower than the default setting, be sure to install an AC reactor option to the input side of the power supply to prevent damage to drive circuitry.

## ■ Kinetic Energy Backup (KEB) Function

In case of a power loss, the KEB function can decelerate the motor and use the rotational energy of the machine to backup/maintain the drive DC bus for a certain period of time. This allows the drive to continue running without interrupting the output power during a momentary power loss. Once the power is restored, the drive smoothly returns to the same operational state before the power loss occurred. The KEB function supports two different operation modes.

### KEB 1

In this mode the drive decelerates the motor based on the deceleration time set in parameter L2-06/C1-09 in order to keep the DC bus voltage level high. When the power supply returns, it uses the time set to L2-07 or the selected acceleration time to accelerate back to the frequency reference.

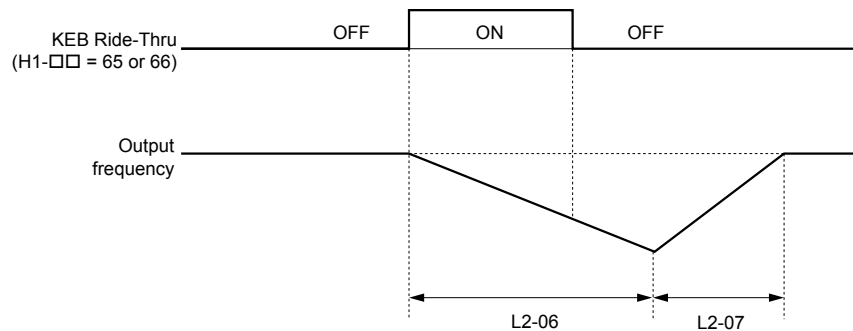


Figure 5.70 KEB Ride-Thru Timing Diagram for Multiple Drives

**Note:** If L2-06 is set to 0.0 s, C1-09 is used instead. If L2-07 is set to 0.0 s, the drive reaccelerates using the selected acceleration time.

Use this method with setting parameters L2-06 and L2-07 if multiple drives must decelerate but still keep the speed ratio between the drives constant during power loss. In this case, a braking resistor is required in order to avoid overvoltage trips.

### KEB 2

In this mode the drive decelerates the motor by calculating the energy of the rotating system. The deceleration rate is continuously adjusted so that the DC bus voltage meets the level set in parameter L2-11. The rotational energy is estimated using the parameters L3-24 and L3-25. When the power supply returns, the drive accelerates back to the frequency reference using the selected acceleration time.

### Activation and Deactivation of the KEB Function

The KEB function requires parameter L2-01 to be set to 1 or 2 and a digital input has to be configured for the KEB 1 (H1-□□ = 65/66) or KEB 2 (H1-□□ = 7A/7B) command. The input has to be enabled during KEB. *Refer to Settings 65 and 66: KEB Ride-Thru 1 (N.C.), 2 (N.O.) on page 170* and *Refer to Settings 7A and 7B: KEB Ride-Thru 2 (N.C., N.O.) on page 172* for details on setting the KEB input commands.

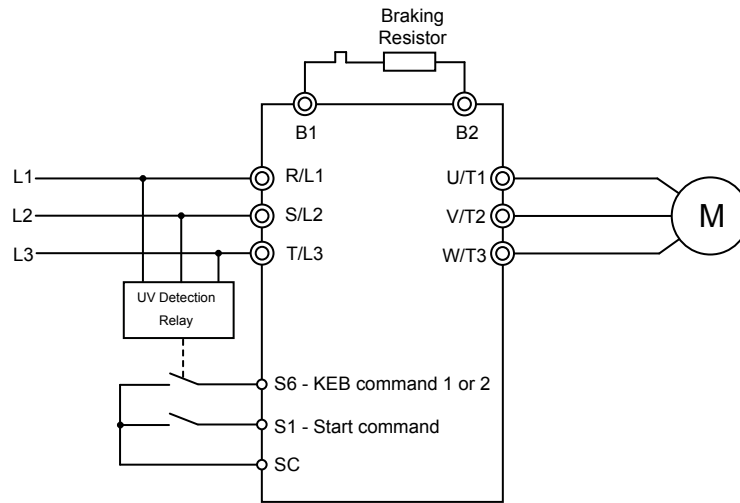
The KEB function is automatically activated when one of the conditions below becomes true.

- The DC bus voltage falls below the level set in parameter L2-05. The KEB input has to be set within 50 ms after the KEB function was activated, or the drive will assume the power supply has returned and attempt to restart.
- The input programmed for KEB 1 or 2 is activated. This input should be triggered by an external undervoltage detection relay.

The KEB function ends when one of the conditions below become true.

- The KEB input was released or
- The function was activated by DC bus voltage detection and no KEB input was set within 50 ms after the KEB activation.

*Figure 5.71* shows a wiring example for triggering the KEB function at power loss using digital input S6.



**Figure 5.71 KEB Function Wiring Example**

**Note:** Make sure the Run command is not switched off when momentary power loss occurs. If the Run command is shut off, the drive will not accelerate back to speed when the power is restored.

### KEB Related Adjustment Parameters

The KEB 1 functions can be adjusted using the following parameters:

- L2-05, Undervoltage Detection Level
- L2-06 or C1-09, KEB Deceleration Time or Fast-stop Time
- L2-07, KEB Acceleration Time
- L2-08, Frequency Gain at KEB Start

Use the following parameters when adjusting the KEB 2 function:

- L2-05, Undervoltage Detection Level
- L2-08, Frequency Gain at KEB Start
- L2-11, Desired DC Bus Voltage during KEB
- L3-20, Main Circuit DC Voltage Adjustment Gain

Sets the proportional gain for controlling the DC bus voltage and keeping it at the desired level during KEB 2 operation.

- L3-21, Accel/Decel Rate Calculation Gain

Sets the gain used to calculate the acceleration or deceleration rate when KEB 2 is active.

- L3-24, Motor Acceleration Time

This value is used to estimate the regenerative power fed back from the mechanics to the drive DC bus during KEB 2.

- L3-25, Load Inertia Ratio

This value is used to estimate the regenerative power fed back from the mechanics to the drive DC bus during KEB 2.

### ■ L2-06: KEB Deceleration Time (KEB 1 only)

Sets the time to decelerate from the frequency reference when the KEB command was input down to zero speed. It can be used to decelerate different drives down to zero in the same time and thereby keep a constant speed ratio.

When L2-06 is set to 0.0 s, the time set in parameter C1-09 (set for deceleration from maximum frequency to zero) is used for the deceleration.

| No.   | Name                  | Setting Range  | Default |
|-------|-----------------------|----------------|---------|
| L2-06 | KEB Deceleration Time | 0.0 to 200.0 s | 0.0 s   |

### ■ L2-07: KEB Acceleration Time (KEB 1 only)

Sets the time to reaccelerate from the speed when KEB was deactivated to the frequency reference. It can be used to accelerate different drives up to their frequency reference in the same time and thereby keep a constant speed ratio.

When set to 0, the drive will accelerate back up to speed according to parameters C1-01 through C1-04 (set for acceleration from zero to maximum frequency).

| No.   | Name                  | Setting Range | Default |
|-------|-----------------------|---------------|---------|
| L2-07 | KEB Acceleration Time | 0.0 to 25.5 s | 0.0 s   |

### ■ L2-08: Frequency Gain at KEB Start (KEB 1 only)

When KEB 1 is activated, the output frequency is reduced in a single step in order to quickly get the motor into a regenerative state. The amount of this frequency reduction can be calculated using the following formula:

Amount of reduction = Slip frequency prior to KEB x (L2-08/100) x 2

| No.   | Name                                | Setting Range | Default |
|-------|-------------------------------------|---------------|---------|
| L2-08 | Minimum Frequency Gain at KEB Start | 0 to 300%     | 100%    |

### ■ L2-11: Desired DC Bus Voltage during KEB (KEB 2 only)

Sets the desired voltage in the DC bus during KEB 2 operation.

| No.   | Name                              | Setting Range    | Default      |
|-------|-----------------------------------|------------------|--------------|
| L2-11 | Desired DC Bus Voltage during KEB | 150 to 400 V <1> | E1-01 x 1.22 |

<1> Values are for 200 V class drives and must be doubled for 400 V class drives.

## ◆ L3: Stall Prevention

When the load is too high or acceleration and deceleration times are too short, the motor may be unable to keep up with the frequency reference, resulting in excessive slip. This “stalling” makes it impossible to decelerate or accelerate. The drive can prevent the motor from stalling and still reach the desired speed without the user needing to change the acceleration or deceleration time settings. The Stall Prevention function can be set separately for acceleration, operating at constant speeds, and deceleration.

### ■ L3-01: Stall Prevention Selection during Acceleration

Stall Prevention during acceleration is used when the motor loses speed during acceleration due to a relatively large load. It prevents overcurrent and motor overload (oL1) from occurring.

This parameter sets the Stall Prevention method for acceleration.

| No.   | Name   | Setting Range | Default |
|-------|--|---------------|---------|
| L3-01 | Stall Prevention Selection during Acceleration | 0 to 2        | 1       |

#### Setting 0: Disabled

No Stall Prevention is provided. If the acceleration time setting is too short, the drive may not be able to accelerate within the set time and the motor may stall.

#### Setting 1: Enabled

Enables Stall Prevention during acceleration.

- When the output current exceeds 85% of the level set in parameter L3-02, the acceleration rate is reduced. The acceleration is stopped when the current exceeds L3-02. Acceleration continues when the current falls below L3-02.

The Stall Prevention level is automatically reduced in the field weakening area. [Refer to L3-03: Stall Prevention Limit During Acceleration on page 198.](#)

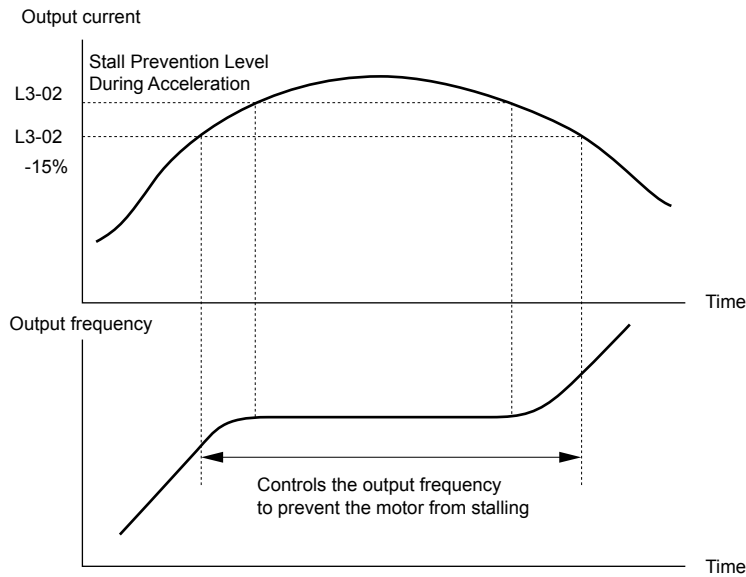


Figure 5.72 Stall Prevention During Acceleration for Induction Motors

### Setting 2: Intelligent Stall Prevention

When L3-01 = 2, the drive will disregard the selected acceleration time and try to accelerate in the minimum time. The acceleration rate is adjusted so that the current does not exceed the value set in parameter L3-02.

#### ■ L3-02: Stall Prevention Level During Acceleration

Sets the output current level at which the Stall Prevention during acceleration is activated.

| No.   | Name                                       | Setting Range | Default |
|-------|--|---------------|---------|
| L3-02 | Stall Prevention Level during Acceleration | 0 to 150% </> | </>     |

<1> Upper limit and default value are dependent on parameter L8-38, Frequency Reduction Selection

- If stalling occurs with L3-02 set to its default value when using a motor that is relatively small compared to the drive, try lowering L3-02.
- When operating the motor in the constant power range, also set parameter L3-03.

#### ■ L3-03: Stall Prevention Limit During Acceleration

The Stall Prevention level is automatically reduced when the motor is operated in the constant power range. L3-03 sets the lower limit for this reduction as a percentage of the drive rated current.

| No.   | Name                                       | Setting Range | Default |
|-------|--|---------------|---------|
| L3-03 | Stall Prevention Limit during Acceleration | 0 to 100%     | 50%     |

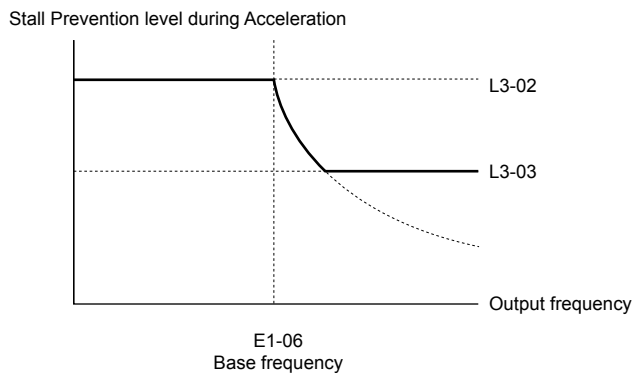


Figure 5.73 Stall Prevention Level and Limit During Acceleration

### ■ L3-04: Stall Prevention Selection during Deceleration

Stall Prevention during deceleration can control the deceleration based on the DC bus voltage and prevent an overvoltage fault caused by high inertia or rapid deceleration.

Selects the Stall Prevention method during deceleration.

| No.   | Name   | Setting Range | Default |
|-------|--|---------------|---------|
| L3-04 | Stall Prevention Selection During Deceleration Selection | 0 to 4; 7     | 0       |

#### Setting 0: Disabled

When this setting is used, the drive decelerates according to the set deceleration time. With high inertia loads or rapid deceleration, an overvoltage (ov) fault may occur. In this case use braking options or switch to another L3-04 selection.

**Note:** Use this setting or set L3-04 to 3 whenever a Dynamic Braking Resistor or another braking option is used.

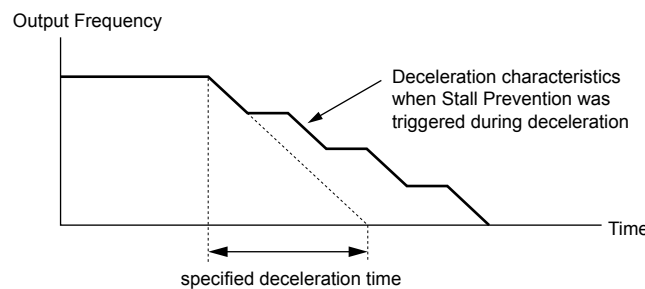
#### Setting 1: General Purpose Stall Prevention

With this setting the drive tries to decelerate in the set deceleration time. When the DC bus voltage exceeds the Stall Prevention level, the drive pauses deceleration. Deceleration continues as soon as the DC bus voltage drops below that level. Stall Prevention may be triggered repeatedly to avoid an overvoltage fault. The DC bus voltage level for Stall Prevention depends on the input voltage setting E1-01.

| Drive Input Voltage |               | Stall Prevention Level during Deceleration |
|---------------------|---------------|--|
| 200 V Class         |               | V <sub>dc</sub> = 380 V                    |
| 400 V Class         | E1-01 ≥ 400 V | V <sub>dc</sub> = 760 V                    |
|                     | E1-01 < 400 V | V <sub>dc</sub> = 660 V                    |

- Note:**
1. This setting should not be used in combination with a Dynamic Braking Resistor or other braking options. If Stall Prevention during deceleration is enabled, it will be triggered before the braking resistor option can operate.
  2. This method may lengthen the total deceleration time compared to the set value. If this is not appropriate for the application consider using a braking option.

**Figure 5.74** illustrates the function of Stall Prevention during deceleration.



**Figure 5.74** Stall Prevention During Deceleration

#### Setting 2: Intelligent Stall Prevention

With this setting the drive adjusts the deceleration rate so that the DC bus voltage is kept at the level set in parameter L3-17. This way the shortest possible deceleration time is achieved while the motor is protected from stalling. The deceleration time that has been selected is disregarded, but the achievable deceleration time cannot be smaller than 1/10 of the set deceleration time.

This function uses the following parameters for adjusting the deceleration rate:

- DC bus voltage gain L3-20
- Deceleration rate calculations gain L3-21
- Inertia calculations for motor acceleration time L3-24
- Load inertia ratio L3-25

Refer to these parameter descriptions for details.

**Note:** As the deceleration time is not constant, Intelligent Stall Prevention should not be used in applications where stopping accuracy is a concern. Use braking options instead.

#### Setting 3: Stall Prevention with Braking Option

Enables the Stall Prevention function while using a braking resistor. Use this setting if overvoltage occurs with L3-04 disabled when using a braking resistor. This makes it possible to reduce the deceleration time.

## 5.8 L: Protection Functions

### Setting 4: Overexcitation Deceleration

Enables overexcitation deceleration. Overexcitation Deceleration (increasing the motor flux) shortens the deceleration time compared to deceleration with no Stall Prevention (L3-04 = 0). Repetitive or long overexcitation deceleration can result in motor overheat. In such situations, either shorten the deceleration time setting or use a braking resistor option.

Use parameters n3-13 and n3-23 for fine-tuning this function.

**Note:** Because the allowable flux level for overexcitation varies based on the flux saturation characteristics of the motor, set the proper overexcitation level by adjusting the excitation gain in parameter n3-13. Motor characteristics and inertia of the machine influence the deceleration time during overexcitation deceleration.

### Setting 7: Overexcitation Deceleration 3

Provides faster deceleration than normal Overexcitation Deceleration (L3-04 = 4) by increasing the amount of overexcitation current applied to the motor.

**Note:** When operation permits, use normal Overexcitation Deceleration (L3-04 = 4).

### ■ L3-05: Stall Prevention Selection During Run

Stall Prevention During Run can prevent a motor from stalling by automatically reducing the speed when a transient overload occurs while the motor is running at constant speed.

This parameter selects the Stall Prevention During Run method.

| No.   | Name                                  | Setting Range | Default |
|-------|---------------------------------------|---------------|---------|
| L3-05 | Stall Prevention Selection During Run | 0 to 2        | 1       |

**Note:** When output frequency is 6 Hz or less, Stall Prevention During Run is disabled regardless of the setting in L3-05/06.

### Setting 0: Disabled

Drive runs at the set frequency reference. A heavy load may cause the motor to stall and trip the drive with an oC or oL fault.

### Setting 1: Decelerate Using C1-02

If the current exceeds the Stall Prevention level set in parameter L3-06, the drive decelerates at Decel Time 1 (C1-02). Once the current level drops below the value of L3-06 minus 2% for 100 ms it accelerates back to the frequency reference at the active acceleration time.

### Setting 2: Decelerate Using C1-04

Same as setting 1 except the drive decelerates at decel time 2 (C1-04).

### ■ L3-06: Stall Prevention Level During Run

Sets the current level for Stall Prevention During Run. Depending on the setting of parameter L3-23 the level is automatically reduced in the constant power range (speed beyond base speed).

| No.   | Name                              | Setting Range | Default |
|-------|-----------------------------------|---------------|---------|
| L3-06 | Stall Prevention Level During Run | 30 to 150 </> | </>     |

</> Upper limit and default value are dependent on parameter L8-38, Frequency Reduction Selection

### ■ L3-11: Overvoltage Suppression Function Selection

Enables or disables the overvoltage suppression function.

| No.   | Name                              | Setting Range | Default |
|-------|-----------------------------------|---------------|---------|
| L3-11 | ov Suppression Function Selection | 0 or 1        | 0       |

### Setting 0: Disabled

The output frequency is not adjusted. A regenerative load may trip the drive with an overvoltage fault. Use this setting if braking options are installed.

### Setting 1: Enabled

When the DC bus voltage rises due to regenerative load, an overvoltage fault is prevented by increasing the output frequency.

### ■ L3-17: Target DC Bus Voltage for Overvoltage Suppression and Stall Prevention

Sets the target DC bus voltage target level used by the overvoltage suppression function (L3-11 = 1) and Intelligent Stall Prevention during deceleration (L3-04 = 2).



| No.   | Name  | Setting Range  | Default       |
|-------|---|----------------|---------------|
| L3-17 | Target DC Bus Voltage for Overvoltage Suppression, and Intelligent Stall Prevention During Deceleration | 150 to 400 <1> | 375 V <1> <2> |

<1> Values are for 200 V class drives and must be doubled for 400 V class drives.

<2> This value is initialized when E1-01 is changed.

### ■ L3-20: DC Bus Voltage Adjustment Gain

Determines the proportional gain used by overvoltage suppression (L3-11 = 1), Kinetic Energy Backup 2, and Intelligent Stall Prevention during deceleration (L3-04 = 2) in order to control the DC bus voltage.

| No.   | Name                           | Setting Range | Default |
|-------|--------------------------------|---------------|---------|
| L3-20 | DC Bus Voltage Adjustment Gain | 0.00 to 5.00  | 1.00    |

#### Adjustment for KEB 2 and Intelligent Stall Prevention During Deceleration

- Increase this setting slowly in steps of 0.1 if overvoltage (ov) or undervoltage (Uv1) occurs at the beginning of deceleration while KEB Ride-Thru 2 is enabled or Intelligent Stall Prevention during deceleration is activated.
- If this setting is too high, then a fair amount of speed or torque ripple can result.

#### Adjustment for Overvoltage Suppression

- Increase this setting slowly in steps of 0.1 if overvoltage suppression is enabled (L3-11 = 1) and a sudden increase in a regenerative load results in an overvoltage (ov) fault.
- If this setting is too high, excessive speed or torque ripple can result.

### ■ L3-21: Accel/Decel Rate Calculation Gain

Determines the proportional gain used by overvoltage suppression (L3-11 = 1), Kinetic Energy Backup 2, and Intelligent Stall Prevention during deceleration (L3-04 = 2) in order to calculate acceleration and deceleration rates.

| No.   | Name                              | Setting Range | Default |
|-------|-----------------------------------|---------------|---------|
| L3-21 | Accel/Decel Rate Calculation Gain | 0.10 to 10.00 | 1.00    |

#### Adjustment for KEB 2 and Intelligent Stall Prevention During Deceleration

- Reduce the setting in steps of 0.05 if there is a fairly large speed or current ripple during KEB Ride-Thru 2 or when using Intelligent Stall Prevention during deceleration.
- Small reductions in the acceleration gain can also help solve problems with overvoltage and overcurrent.
- Decreasing this setting too much can result in a slow DC bus voltage control response and may also lengthen deceleration times beyond optimal levels.

#### Adjustment for Overvoltage Suppression

- Increase this setting in steps of 0.1 if overvoltage occurs as a result of a regenerative load when overvoltage suppression is enabled (L3-11 = 1).
- If there is a fairly large speed ripple when overvoltage suppression is enabled, then decrease L3-21 in steps of 0.05.

### ■ L3-23: Automatic Stall Prevention Level Reduction

This function reduces the Stall Prevention during run level in the constant power range.

| No.   | Name   | Setting Range | Default |
|-------|--|---------------|---------|
| L3-23 | Automatic Reduction Function Selection for Stall Prevention during Run | 0 or 1        | 0       |

#### Setting 0: Disabled

The level set in L3-06 is used throughout the entire speed range.

#### Setting 1: Enabled

The Stall Prevention level during run is reduced in the constant power range. The lower limit will be 40% of L3-06.

### ■ Overvoltage Suppression Function

This function suppresses overvoltage faults by slightly increasing the output frequency when the DC bus voltage rises. It can be used to drive loads with cyclic regenerative operation, such as punch presses or other applications that involve repetitive crank movements.

## 5.8 L: Protection Functions

The output frequency is adjusted during ov suppression so that the DC bus voltage does not exceed the level set in parameter L3-17. In addition to the parameters explained below, ov suppression also uses these settings for frequency adjustment:

- DC bus voltage gain L3-20
- Deceleration rate calculations gain L3-21
- Inertia calculations for motor acceleration time L3-24
- Load inertia ratio L3-25

- Note:**
1. The motor speed will exceed the frequency reference when overvoltage suppression is triggered. Consequently, overvoltage suppression is not appropriate in applications that require a perfect match between the frequency reference and the actual motor speed.
  2. Disable overvoltage suppression when using a braking resistor.
  3. Overvoltage may still occur if there is a sudden increase to a regenerative load.
  4. This function is enabled only when operating just below the maximum frequency. Overvoltage suppression does not increase the output frequency beyond the maximum frequency. If this is required by the application increase the maximum frequency and change the base frequency setting.

### ■ L3-24: Motor Acceleration Time for Inertia Calculations

Sets the time it takes to accelerate the motor from stop to the maximum speed at motor rated torque. This parameter should be set when using KEB Ride-Thru 2, Intelligent Stall Prevention during deceleration (L2-04 = 2), or the overvoltage suppression function (L3-11 = 1).

| No.   | Name   | Setting Range   | Default |
|-------|--|-----------------|---------|
| L3-24 | Motor Acceleration Time for Inertia Calculations | 0.001 to 10.000 | <1>     |

<1> Parameter value changes automatically if E2-11 is manually changed or changed by Auto-Tuning. Default setting is dependent on parameter o2-04, Drive Model Selection.

Calculations are made as follows:

$$L3-24 = \frac{2 \cdot \pi \cdot J \text{ [kgm}^2\text{]} \cdot n_{\text{rated}} \text{ [r/min]}}{60 \cdot T_{\text{rated}} \text{ [Nm]}}$$

The rated torque can be calculated as follows:

$$T_{\text{rated}} \text{ [Nm]} = \frac{60 \cdot P_{\text{Motor}} \text{ [kW]} \cdot 10^3}{2 \cdot \pi \cdot n_{\text{rated}} \text{ [r/min]}}$$

### ■ L3-25: Load Inertia Ratio

Determines the ratio between the rotor inertia and the load. Set this parameter when using KEB Ride-Thru 2, Intelligent Stall Prevention during deceleration (L3-04 = 2), or the overvoltage suppression function (L3-11 = 1).

| No.   | Name               | Setting Range | Default |
|-------|--------------------|---------------|---------|
| L3-25 | Load Inertia Ratio | 1.0 to 1000.0 | 1.0     |

When set incorrectly, a fairly large current ripple can result during KEB Ride-Thru 2 and overvoltage suppression (L3-11 = 1) or other faults such as ov, UvI, and oC may occur.

Parameter L3-25 can be calculated by:

$$L3-25 = \frac{\text{Machine Inertia}}{\text{Motor Inertia}}$$

## ◆ L4: Speed Agree/Frequency Reference Loss Detection

These parameters set up the speed agree and speed detection functions which can be assigned to the multi-function output terminals.

### ■ L4-01/02: Speed Agreement Detection Level and Detection Width

Parameter L4-01 sets the detection level for the digital output functions “Speed Agree 1”, “User Set Speed Agree 1”, “Frequency Detection 1”, and “Frequency Detection 2”.

Parameter L4-02 sets the hysteresis level for these functions.

| No.   | Name                            | Setting Range   | Default |
|-------|---------------------------------|-----------------|---------|
| L4-01 | Speed Agreement Detection Level | 0.0 to 400.0 Hz | 0.0 Hz  |
| L4-02 | Speed Agreement Detection Width | 0.0 to 20.0 Hz  | 2.0 Hz  |

Refer to H2-01 to H2-03: Terminal MA/MB/MC, P1/PC, and P2/PC Function Selection on page 174, Settings 2, 3, 4, and 5.

#### ■ L4-03/04: Speed Agreement Detection Level and Detection Width (+/-)

Parameter L4-03 sets the detection level for the digital output functions “Speed Agree 2”, “User Set Speed Agree 2”, “Frequency Detection 3”, and “Frequency Detection 4”.

Parameter L4-04 sets the hysteresis level for these functions.

| No.   | Name                                  | Setting Range   | Default |
|-------|---------------------------------------|-----------------|---------|
| L4-03 | Speed Agreement Detection Level (+/-) | 0.0 to 400.0 Hz | 0.0 Hz  |
| L4-04 | Speed Agreement Detection Width (+/-) | 0.0 to 20.0 Hz  | 2.0 Hz  |

Refer to H2-01 to H2-03: Terminal MA/MB/MC, P1/PC, and P2/PC Function Selection on page 174, Settings 13, 14, 15, and 16.

#### ■ L4-05: Frequency Reference Loss Detection Selection

The drive can detect a loss of an analog frequency reference from input A1 or A2. Reference loss is detected when the frequency reference value reduces for 90% within 400 ms.

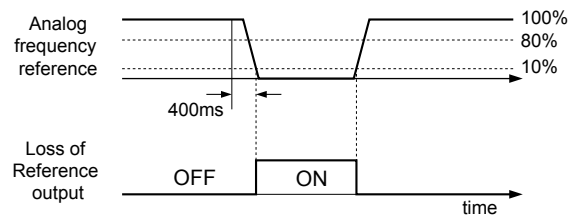


Figure 5.75 Loss of Reference Function

To have a fault output trigger when frequency reference loss occurs, set H2-01, H2-02, or H2-03 to “C”. Refer to Setting C: Frequency Reference Loss on page 177 for details on setting the output function.

Parameter L4-05 selects the operation when a frequency reference loss is detected.

| No.   | Name   | Setting Range | Default |
|-------|--|---------------|---------|
| L4-05 | Frequency Reference Loss Detection Selection | 0 or 1        | 0       |

##### Setting 0: Stop

The drive will stop the motor.

##### Setting 1: Continue Operation with Reduced Frequency Reference

The drive will continue operation at the frequency reference value set in parameter L4-06. When the external frequency reference value is restored, the operation is continued with the frequency reference.

#### ■ L4-06: Frequency Reference at Reference Loss

Sets the frequency reference level the drive runs with when L4-05 = 1 and a reference loss was detected. The value is set as a percentage of the frequency reference before the loss was detected.

| No.   | Name                                  | Setting Range | Default |
|-------|---------------------------------------|---------------|---------|
| L4-06 | Frequency Reference at Reference Loss | 0.0 to 100.0% | 80.0%   |

#### ■ L4-07: Speed Agreement Detection Selection

Determines when frequency detection is active using parameters L4-01 through L4-04.

| No.   | Name                                | Setting Range | Default |
|-------|-------------------------------------|---------------|---------|
| L4-07 | Speed Agreement Detection Selection | 0, 1          | 0       |

## 5.8 L: Protection Functions

### Setting 0: No Detection During Baseblock

### Setting 1: Detection Always Enabled

## ◆ L5: Fault Restart

The drive can be set up to perform a self-diagnostic check and resume the operation after a fault has occurred. If the self-check is successful and the cause of the fault has disappeared, the drive restarts by performing Speed Search.

The drive can attempt to restart itself following the faults listed below.

Table 5.26 Restart Faults

| Setting | Function            | Setting | Function                   |
|---------|---------------------|---------|----------------------------|
| GF      | (Ground Fault)      | ov      | (DC Bus Overvoltage)       |
| LF      | (Output Open Phase) | PF      | (Input Phase Loss)         |
| oC      | (Overcurrent)       | rH      | (Braking Resistor Fault)   |
| oH1     | (Drive Overheat)    | rr      | (Braking Transistor Fault) |
| oL1     | (Motor Overload)    | STo     | (Step Out Detection)       |
| oL2     | (Drive Overload)    | Uv1     | (DC Bus Undervoltage) </>  |
| oL3     | (Overtorque 1)      |         |                            |
| oL4     | (Overtorque 2)      |         |                            |

<1> When L2-01 is set to 1 or 2 (continue operation during momentary power loss)

To output a signal during fault restart, set H2-01, H2-02, or H2-03 to 1E.

### ■ L5-01: Number of Auto Restart Attempts

Sets the number of times that the drive may attempt to restart itself.

When the counter reaches the number set to L5-01, the operation stops and the fault must be manually cleared and reset.

The restart counter is incremented at each restart attempt, regardless of whether the attempt was successful. When the counter reaches the number set to L5-01, the operation stops and the fault must be manually cleared and reset.

The number of fault restarts is reset to zero when:

- The drive operates normally for 10 minutes following a fault restart.
- A fault is cleared manually after protective functions are triggered.
- The power supply is cycled.

| No.   | Name                            | Setting Range | Default |
|-------|---------------------------------|---------------|---------|
| L5-01 | Number of Auto Restart Attempts | 0 to 10 Times | 5 Times |

### ■ L5-02: Auto Restart Fault Output Operation Selection

Selects if the fault output (H2-01/02/03 = E) is set when the drive attempts to restart.

| No.   | Name  | Setting Range | Default |
|-------|---|---------------|---------|
| L5-02 | Auto Restart Fault Output Operation Selection | 0 or 1        | 0       |

### Setting 0: No Fault Output

### Setting 1: Fault Output is Set

### ■ L5-04: Fault Reset Interval Time

Determines the amount of time to wait between restart attempts when parameter L5-05 is set to 1.

| No.   | Name                      | Setting Range    | Default |
|-------|---------------------------|------------------|---------|
| L5-04 | Fault Reset Interval Time | 10.0 to 3600.0 s | 20.0 s  |

### ■ Auto Restart for Faults

The Auto Restart function several faults can be disabled and enabled in parameters L5-40 to L5-53.

### ■ L5-40: Low Feedback Fault Retry Selection

| No.   | Name                               | Setting Range | Default |
|-------|------------------------------------|---------------|---------|
| L5-40 | Low Feedback Fault Retry Selection | 0, 1          | 0       |

Setting 0: No retry

Setting 1: Retry

### ■ L5-41: High Feedback Fault Retry Selection

| No.   | Name                                | Setting Range | Default |
|-------|-------------------------------------|---------------|---------|
| L5-41 | High Feedback Fault Retry Selection | 0, 1          | 0       |

Setting 0: No retry

Setting 1: Retry

### ■ L5-42: Feedback Loss Fault Retry Selection

| No.   | Name                                | Setting Range | Default |
|-------|-------------------------------------|---------------|---------|
| L5-42 | Feedback Loss Fault Retry Selection | 0, 1          | 0       |

Setting 0: No retry

Setting 1: Retry

### ■ L5-50: Setpoint Not Met Retry Selection

| No.   | Name                             | Setting Range | Default |
|-------|----------------------------------|---------------|---------|
| L5-50 | Setpoint Not Met Retry Selection | 0, 1          | 0       |

Setting 0: No retry

Setting 1: Retry

### ■ L5-51: Loss of Prime Fault Retry Selection

| No.   | Name                                | Setting Range | Default |
|-------|-------------------------------------|---------------|---------|
| L5-51 | Loss of Prime Fault Retry Selection | 0, 1          | 0       |

Setting 0: No retry

Setting 1: Retry

### ■ L5-52: Pump Over Cycle Fault Retry Selection

| No.   | Name                                  | Setting Range | Default |
|-------|---------------------------------------|---------------|---------|
| L5-52 | Pump Over Cycle Fault Retry Selection | 0, 1          | 0       |

Setting 0: No retry

Setting 1: Retry

### ■ L5-53: Volute-Thermostat Retry Selection

| No.   | Name                              | Setting Range | Default |
|-------|-----------------------------------|---------------|---------|
| L5-53 | Volute-Thermostat Retry Selection | 0, 1          | 0       |

### ■ Volute Thermostat Digital Inputs

There are two multi-function digital input settings, one normally open (closed causes the fault) and one normally closed (open causes the fault). Only one of these inputs may be programmed into the H1-□□ parameters at a time.

Setting 0: No retry

Setting 1: Retry

When automatic retries are enabled (L5-01 > 0) and the drive faults on FLTS – Volute-TStat Flt , the drive will wait for the Volute-Thermostat digital input to deactivate plus the L5-04 time before the drive will restart.

### ◆ L6: Torque Detection

The drive provides two independent torque detection functions that trigger an alarm or fault signal when the load is too heavy (oL), or suddenly drops (UL). They are set up using the L6-□□ parameters. To indicate the underload or overload condition to an external device, digital outputs should be programmed as shown below.

## 5.8 L: Protection Functions

| H2-01 /02/03 Setting | Description  |
|----------------------|--|
| B                    | Torque detection 1, N.O. (output close when over-/underload is detected) |
| 17                   | Torque detection 1, N.C. (output opens when over-/underload is detected) |
| 18                   | Torque detection 2, N.O. (output close when over-/underload is detected) |
| 19                   | Torque detection 2, N.C. (output opens when over-/underload is detected) |

Figure 5.76 and Figure 5.77 show the function of overtorque and undertorque detection.

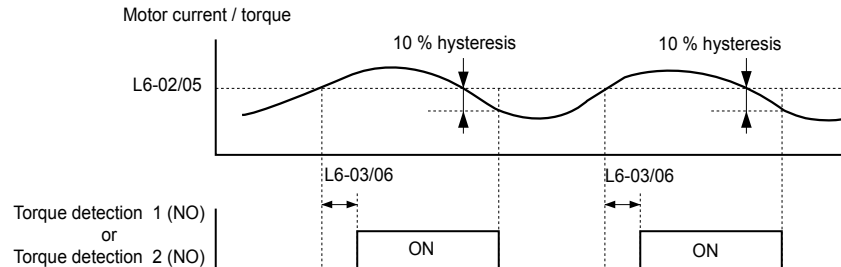


Figure 5.76 Overtorque Detection Operation

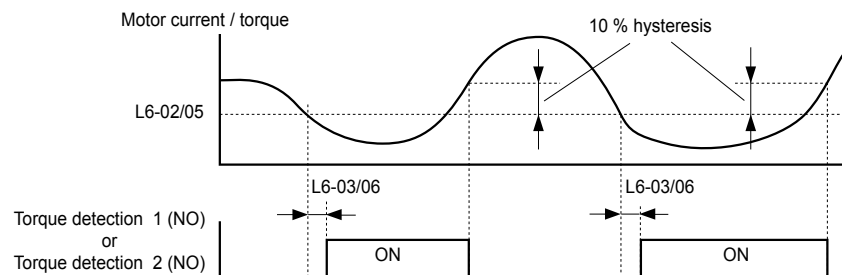


Figure 5.77 Undertorque Detection Operation

**Note:** The torque detection function uses a hysteresis of 10% of the drive rated output current/motor rated torque.

**Note:** When overtorque occurs in the application, the drive may stop due to overcurrent (oC) or overload (oL1). To prevent this, an overload situation should be indicated to the controller before oC or oL1 occur in the drive. Use the torque detection for this purpose. Use undertorque detection to discover application problems like a torn belt, a pump shutting off, or other similar trouble.

### ■ L6-01/L6-04: Torque Detection Selection 1/2

The torque detection function is triggered when the current/torque exceeds the levels set in parameter L6-02/L6-05 for longer than the time set in L6-03/L6-06. The parameters L6-01/L6-04 select the detection condition and the operation at detection.

| No.          | Name                           | Setting Range | Default |
|--------------|--------------------------------|---------------|---------|
| L6-01/ L6-04 | Torque Detection Selection 1/2 | 0 to 8        | 0       |

#### Setting 0: Disabled

#### Setting 1: oL3/oL4 at Speed Agree - Alarm

Overtorque detection is active only when the output speed is equal to the frequency reference, i.e., no detection during acceleration and deceleration. The operation continues after detection and an oL3/oL4 alarm is triggered.

#### Setting 2: oL3/oL4 at Run - Alarm

Overtorque detection works whenever a Run command is active. The operation continues after detection and an oL3/oL4 alarm is triggered.

#### Setting 3: oL3/oL4 at Speed Agree - Fault

Overtorque detection is active only when the output speed is equal to the frequency reference, i.e., no detection during acceleration and deceleration. The operation is stopped and an oL3/oL4 fault is triggered.

**Setting 4: oL3/oL4 at Run - Fault**

Overtorque detection works whenever a Run command is active. The operation is stopped and an oL3/oL4 fault is triggered.

**Setting 5: UL3/UL4 at Speed Agree - Alarm**

Undertorque detection is active only when the output speed is equal to the frequency reference, i.e., no detection during acceleration and deceleration. The operation continues after detection and a UL3/UL4 alarm is triggered.

**Setting 6: oL5/UL5 at Run - Alarm**

Undertorque detection works whenever a Run command is active. The operation continues after detection and an oL5/UL5 alarm is triggered.

**Setting 7: UL5 at Speed Agree - Fault**

Undertorque detection is active only when the output speed is equal to the frequency reference, i.e., no detection during acceleration and deceleration. The operation is stopped and a UL5 fault is triggered.

**Setting 8: oL3/oL4 at Run - Fault**

Undertorque detection works whenever a Run command is active. The operation is stopped and an oL3/oL4 fault is triggered.

**Setting 9: UL6 Alarm at Speed Agree****Setting 10: UL6 Alarm during Run****Setting 11: UL6 Fault at Speed Agree****Setting 12: UL6 Fault during Run****■ L6-02/L6-05: Torque Detection Level 1/2**

These parameters the detection levels for the torque detection functions 1 and 2.

| No.   | Name                     | Setting Range | Default |
|-------|--------------------------|---------------|---------|
| L6-02 | Torque Detection Level 1 | 0 to 300%     | 150%    |
| L6-05 | Torque Detection Level 2 | 0 to 300%     | 150%    |

- Note:**
1. The torque detection level 1 (L6-02) can also be supplied by an analog input set to H3-02/10 = 7. In this case the analog value has priority and the setting L6-02 is disregarded. Torque detection level 2 (L6-05) cannot be set by an analog input.
  2. The detection levels for overtorque and undertorque are set as a percentage of the drive rated current when using V/f Control or Open Loop Vector Control. When using Closed Loop Vector Control, the drive sets torque detection as a percentage of the motor rated current.

**■ L6-03/L6-06: Torque Detection Time 1/2**

These parameters set the time that the levels set in L6-02/05 have to be exceeded before an alarm/fault is triggered.

| No.   | Name                    | Setting Range | Default |
|-------|-------------------------|---------------|---------|
| L6-03 | Torque Detection Time 1 | 0.0 to 10.0 s | 0.1 s   |
| L6-06 | Torque Detection Time 2 | 0.0 to 10.0 s | 0.1 s   |

**■ L6-13: Motor Underload Protection Selection**

Sets the motor underload protection (UL6) based on motor load.

| No.   | Name                                 | Setting Range | Default |
|-------|--------------------------------------|---------------|---------|
| L6-13 | Motor Underload Protection Selection | 0, 1          | 0       |

**Setting 0: Base frequency enable****Setting 1: Max frequency enable****■ L6-14: Motor Underload Protection Level at Minimum Frequency**

Sets the motor underload protection (UL6) based on motor load.

| No.   | Name  | Setting Range | Default |
|-------|---|---------------|---------|
| L6-14 | Motor Underload Protection Level at Minimum Frequency | 0 to 300%     | 15%     |

**◆ L8: Hardware Protection**

## 5.8 L: Protection Functions

### ■ L8-01: Internal Dynamic Braking Resistor Protection Selection (ERF type)

This parameter selects the dynamic braking resistor protection when using an optional heatsink mounted braking resistor (ERF type, 3% ED).

| No.   | Name                                 | Setting Range | Default |
|-------|--------------------------------------|---------------|---------|
| L8-01 | Internal Braking Resistor Protection | 0 or 1        | 0       |

#### Setting 0: Disabled

Disables the braking resistor protection. Use this setting for any braking option other than the Yaskawa ERF Type resistor.

#### Setting 1: Enabled

Enables the protection for ERF type resistors.

### ■ L8-02: Overheat Alarm Level

Sets the overheat alarm (oH) detection level.

The drive will output an alarm when the heatsink temperature exceeds the alarm level set in parameter L8-02. If the temperature reaches the overheat fault level, the drive will trigger an oH1 fault and stop operation.

When an output terminal is set for the oH pre-alarm (H2-01/02/03 = 20), the switch will close when the heatsink temperature rises above L8-02.

| No.   | Name                 | Setting Range | Default                |
|-------|----------------------|---------------|------------------------|
| L8-02 | Overheat Alarm Level | 50 to 130 °C  | Determined by<br>o2-04 |

### ■ L8-03: Overheat Pre-Alarm Operation Selection

Sets the operation when an overheat pre-alarm is detected.

| No.   | Name                         | Setting Range | Default |
|-------|------------------------------|---------------|---------|
| L8-03 | Overheat Pre-Alarm Operation | 0 to 4        | 3       |

#### Setting 0: Ramp to Stop

If an overheat alarm occurs, the drive decelerates to stop using the selected deceleration time. If a digital output is programmed for “fault” (H2-01/02/03 = E), this output will be triggered.

#### Setting 1: Coast to Stop

If an overheat alarm occurs, the drive switches off the output and the motor coasts to stop. If a digital output is programmed for “fault” (H2-01/02/03 = E), this output will be triggered.

#### Setting 2: Fast-stop

If an overheat alarm occurs, the drive decelerates to stop using the Fast-stop time (C1-09). If a digital output is programmed for “fault” (H2-01/02/03 = E), this output will be triggered.

#### Setting 3: Alarm Only

If an overheat alarm occurs, an alarm is output and the drive continues operation.

#### Setting 4: Operation with Reduced Speed

If an overheat alarm occurs, the operation is continued but the speed is reduced to the level set in parameter L8-19. If after 10 s the oH alarm is still present, the speed is reduced once more. The amount of reduction depends on how often the alarm repeats. If the oH alarm disappears while the drive is operating at a reduced speed, then the drive will switch back to the previous speed it was reduced to before. *Figure 5.78* explains the operation with reduced speed during an oH alarm. A digital output programmed for 4D is switched when the oH alarm is still active after ten reduction cycles.



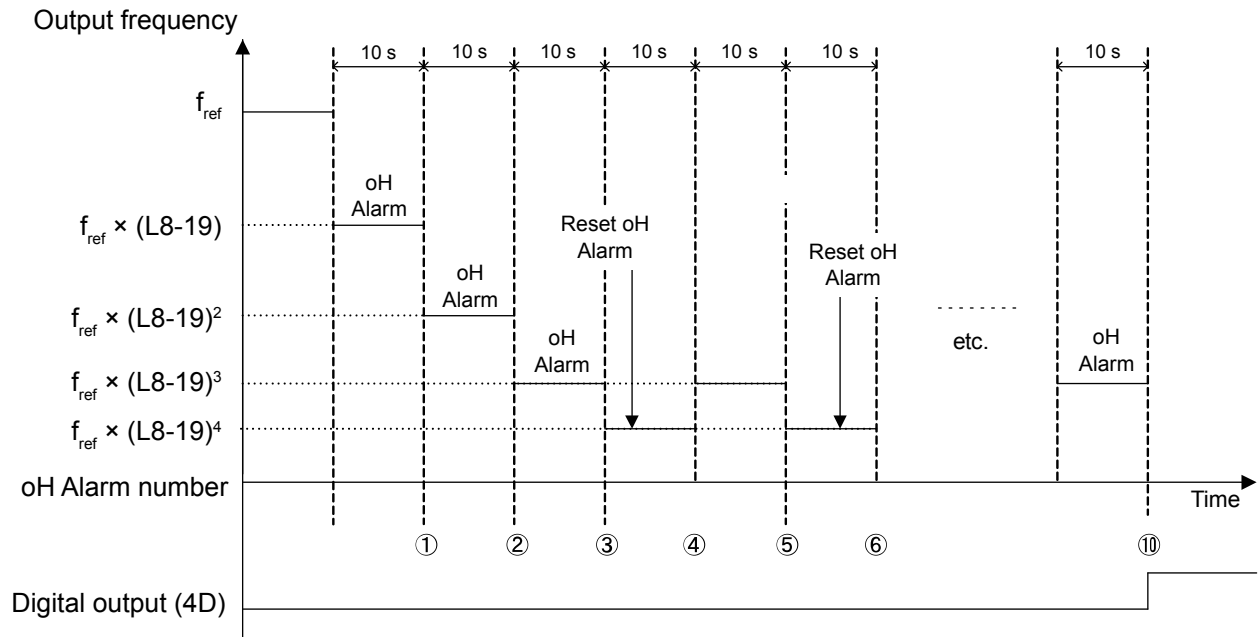


Figure 5.78 Output Frequency Reduction During Overheat Alarm

■ **L8-19: Frequency Reduction Rate During Overheat Pre-Alarm**

Specifies how much the output frequency is reduced when L8-03 is set to 4 and an oH alarm is present. Set as a factor of the maximum output frequency.

| No.   | Name   | Setting Range | Default |
|-------|--|---------------|---------|
| L8-19 | Frequency Reduction Rate During oH Pre-Alarm | 0.1 to 0.9    | 0.8     |

■ **L8-05: Input Phase Loss Protection Selection**

Enables or disables the input phase loss detection.

| No.   | Name                                 | Setting Range | Default |
|-------|--------------------------------------|---------------|---------|
| L8-05 | Input Phase Loss Detection Selection | 0 or 1        | 1       |

**Setting 0: Disabled**

**Setting 1: Enabled**

Enables the input phase loss detection. As detection is performed by measuring the DC bus ripple, a phase loss fault (PF) can also be triggered by power supply voltage imbalance or main circuit capacitor deterioration. Detection is disabled when:

- The drive is decelerating.
- No Run command is active.
- Output current is less than or equal to 30% of the drive rated current.

■ **L8-07: Output Phase Loss Protection Selection**

Enables or disables the output phase loss detection, which is triggered when the output current falls below 5% of the drive rated current.

**Note:** Output phase loss detection can mistakenly be triggered if the motor rated current is very small compared to the drive rating. Disable this parameter in such cases.

| No.   | Name                                   | Setting Range | Default |
|-------|--|---------------|---------|
| L8-07 | Output Phase Loss Protection Selection | 0 to 2        | 1       |

**Setting 0: Disabled**

**Setting 1: Fault when One Phase is Lost**

An output phase loss fault (LF) is triggered when one output phase is lost. The output shuts off and the motor coasts to stop.

## 5.8 L: Protection Functions

### Setting 2: Fault when Two Phases are Lost

An output phase loss fault (LF) is triggered when two output phases are lost. The output shuts off and the motor coasts to stop.

#### ■ L8-09: Output Ground Fault Detection Selection

Enables or disables the output ground fault detection.

| No.   | Name                          | Setting Range | Default |
|-------|-------------------------------|---------------|---------|
| L8-09 | Output Ground Fault Detection | 0 or 1        | 0       |

#### Setting 0: Disabled

Ground faults are not detected.

#### Setting 1: Enabled

A ground fault (GF) is triggered when high leakage current or a ground short circuit occurs in one or two output phases.

#### ■ L8-10: Heatsink Cooling Fan Operation Selection

Selects the heatsink cooling fan operation.

| No.   | Name                    | Setting Range | Default |
|-------|-------------------------|---------------|---------|
| L8-10 | Fan Operation Selection | 0 or 1        | 0       |

#### Setting 0: Run with Timer

The fan is switched on when a Run command is active. It is switched off with the delay set in parameter L8-11 after the Run command has been released. Using this setting extends the fan lifetime.

#### Setting 1: Run always

The fan runs whenever power is supplied to the drive.

#### ■ L8-11: Heatsink Cooling Fan Off Delay Time

Sets the cooling fan switch off delay time if parameter L8-10 is set to 0.

| No.   | Name                         | Setting Range | Default |
|-------|------------------------------|---------------|---------|
| L8-11 | Cooling Fan Switch Off Delay | 0 to 300 s    | 60 s    |

#### ■ L8-12: Ambient Temperature Setting

If the temperature where the drive is mounted is above the specified values, the drive rated current must be reduced for optimal performance life. By setting the ambient temperature to parameter L8-12 and adjusting the installation method setting in L8-35, the drive rating automatically adapts to safe values.

| No.   | Name                        | Setting Range | Default |
|-------|-----------------------------|---------------|---------|
| L8-12 | Ambient Temperature Setting | -10 to +50 °C | 40 °C   |

#### ■ L8-15: oL2 Characteristics Selection at Low Speeds

Selects whether the drive overload capability (oL fault detection level) is reduced at low speeds in order to prevent premature output transistor failures.

| No.   | Name                             | Setting Range | Default |
|-------|----------------------------------|---------------|---------|
| L8-15 | oL2 Characteristics at Low Speed | 0 or 1        | 1       |

#### Setting 0: Disabled

The overload protection level is not reduced. Frequently operating the drive with high output current at low speed can lead to premature drive faults.

#### Setting 1: Enabled

The overload protection level (oL2 fault detection level) is automatically reduced at speeds below 6 Hz.

### ■ L8-18: Software Current Limit Selection

The Software Current Limit (CLA) is a drive protection function that prevents output transistor failures caused by high current. Parameter L8-18 enables or disables this function.

**Note:** This setting should not be changed unless absolutely necessary. For proper drive protection and operation leave the Software CLA function enabled.

| No.   | Name                             | Setting Range | Default |
|-------|----------------------------------|---------------|---------|
| L8-18 | Software Current Limit Selection | 0 or 1        | 0       |

#### Setting 0: Disabled

The drive may trip on an oC fault if the load is too heavy or the acceleration is too short.

#### Setting 1: Enabled

When the soft CLA current level is reached, the drive reduces the output voltage in order to reduce the current. If the current level drops below the Software CLA level, then normal operation will continue.

### ■ L8-35: Installation Method Selection

Selects the type of installation and changes the drive overload (oL2) limits accordingly.

- Note:**
1. This parameter is not reset when the drive is initialized.
  2. The value is preset to the appropriate value when the drive is shipped. Change the value only when using Side-by-Side installation or when mounting a standard drive with the heatsink outside the cabinet.

| No.   | Name                          | Setting Range | Default             |
|-------|-------------------------------|---------------|---------------------|
| L8-35 | Installation Method Selection | 0 to 3        | Determined by o2-04 |

#### Setting 0: IP20/IP00 Drive

Must be selected if an IP20/IP00 drive is installed with a minimum of 30 mm space to the next drive or a cabinet wall.

#### Setting 1: Side-by-Side Mounting

Must be selected if drives are Side-by-Side mounted with a minimum space of 2 mm.

#### Setting 2: NEMA 1, UL Type 1 Drive

Must be selected if the drive has a NEMA 1, UL Type 1 enclosure or an IP20/Open-Chassis drive fitted with the NEMA 1, UL Type 1 Kit option.

#### Setting 3: Finless Drive or External Heatsink Installation

Must be selected for finless drives or if a standard drive is mounted with the heatsink outside the cabinet.

### ■ L8-38: Carrier Frequency Reduction Selection

The drive can reduce the carrier frequency when the output current exceeds a certain level. This temporarily increases the overload capability (oL2 detection) and the drive can run through transient load peaks without tripping.

L8-38 selects the operation of the carrier frequency reduction function.

| No.   | Name                                  | Setting Range | Default |
|-------|---------------------------------------|---------------|---------|
| L8-38 | Carrier Frequency Reduction Selection | 0 to 2        | 1       |

#### Setting 0: Disabled

No carrier frequency reduction at high current.

#### Setting 1: Enabled for Output Frequencies below 6 Hz

The carrier frequency is reduced at speeds below 6 Hz when the current exceeds 100% of the drive rated current. The drive returns to its normal carrier frequency when the current falls below 88% or the output frequency exceeds 7 Hz.

#### Setting 2: Enabled for Entire Frequency Range

The carrier frequency is reduced at the following speeds:

- Below 6 Hz when the current exceeds 100% of the drive rated current.
- Above 7 Hz when the current exceeds 112% of the drive rated current.

The drive uses the delay time set in parameter L8-40 and a hysteresis of 12% when switching the carrier frequency back to the set value.

## 5.8 L: Protection Functions

---

### ■ L8-40: Carrier Frequency Reduction Off Delay Time

Sets the delay time which is used to switch back to the normal carrier frequency. The carrier frequency reduction function is disabled if this value is 0 s.

| No.   | Name                                 | Setting Range  | Default |
|-------|--------------------------------------|----------------|---------|
| L8-40 | Low Carrier Frequency Off Delay Time | 0.00 or 2.00 s | 0.50 s  |

### ■ L8-41: High Current Alarm Selection

The drive can be set to trigger a high current alarm (HCA) when the output current rises too high.

| No.   | Name                         | Setting Range | Default |
|-------|------------------------------|---------------|---------|
| L8-41 | High Current Alarm Selection | 0 or 1        | 0       |

#### Setting 0: Disabled

No alarm is output.

#### Setting 1: Enabled

An alarm is triggered when the output current exceeds 150% of the drive rated current. A digital output indicating an alarm (H2-01/02/03 = 10) can be programmed.

## 5.9 n: Special Adjustments

The n parameters handle a variety of specialized adjustments and functions, including Hunting Prevention.

### ◆ n1: Hunting Prevention

Hunting Prevention keeps the drive from hunting as a result of low inertia and operating with light load.

#### ■ n1-01: Hunting Prevention Selection

Enables or disables the Hunting Prevention function.

**Note:** Hunting Prevention should be disabled when drive response is need over suppressing motor oscillation. This function can also be disabled without any problems in applications with high inertia loads or relatively heavy loads.

| No.   | Name                         | Setting Range | Default |
|-------|------------------------------|---------------|---------|
| n1-01 | Hunting Prevention Selection | 0 or 1        | 1       |

**Setting 0: Disabled**

**Setting 1: Enabled**

#### ■ n1-02: Hunting Prevention Gain Setting

Sets the gain for the Hunting Prevention Function.

| No.   | Name                            | Setting Range | Default |
|-------|---------------------------------|---------------|---------|
| n1-02 | Hunting Prevention Gain Setting | 0.00 to 2.50  | 1.00    |

Normally, n1-02 does not need to be changed, but adjustment may help under the following conditions:

- If the motor vibrates while lightly loaded and n1-01 = 1, increase the gain by 0.1 until vibration ceases.
- If the motor stalls while n1-01 = 1, decrease the gain by 0.1 until the stalling ceases.

#### ■ n1-03: Hunting Prevention Time Constant

Determines how responsive the Hunting Prevention function is (affects the primary delay time for Hunting Prevention).

| No.   | Name                             | Setting Range | Default             |
|-------|----------------------------------|---------------|---------------------|
| n1-03 | Hunting Prevention Time Constant | 0 to 500 ms   | Determined by o2-04 |

#### ■ n1-05: Hunting Prevention Gain while in Reverse

This parameter is the same as n1-02, except that it is used when the motor rotates in reverse. See the setting instructions for n1-02.

**Note:** When set to 0 ms, n1-02 is enabled even when the drive is operating in reverse.

| No.   | Name                                     | Setting Range | Default |
|-------|--|---------------|---------|
| n1-05 | Hunting Prevention Gain while in Reverse | 0.00 to 2.50  | 0.00    |

### ◆ n3: Overexcitation Braking

#### ■ n3-13: Overexcitation Deceleration Gain

Applies a gain to the V/f pattern output value during overexcitation deceleration, thereby determining the level of overexcitation. The drive returns to the normal V/f value after the motor has stopped or when it is accelerating to the frequency reference.

| No.   | Name                             | Setting Range | Default |
|-------|----------------------------------|---------------|---------|
| n3-13 | Overexcitation Deceleration Gain | 1.00 to 1.40  | 1.10    |

The optimum setting for n3-13 depends on the motor flux saturation characteristics.

- Increase the gain by 1.25 to 1.30 to improve the breaking power of overexcitation.
- Reduce the value when the motor slip gets too high, which can trigger overcurrent (oC), motor overload (oL1), or drive overload (oL2) faults. Alternatively reduce n3-21.

## 5.9 n: Special Adjustments

---

### ■ n3-21: High Slip Suppression Current Level

If overcurrent, oL1, or oL2 occur during overexcitation deceleration, reduce the overslip suppression current level. Set as a percentage of the drive rated current.

Reduce this setting if the current during overexcitation deceleration exceeds the overslip suppression current set in n3-21 as a result of flux saturation and excessive slip. Alternatively reduce the overexcitation gain n3-13.

| No.   | Name                               | Setting Range | Default |
|-------|------------------------------------|---------------|---------|
| n3-21 | Overslip Suppression Current Level | 0 to 150%     | 100%    |

### ■ n3-23: Overexcitation Operation Selection

Determines which direction overexcitation can be used in. However, parameter L3-04 must be set to 4 in order for n3-23 to be enabled.

| No.   | Name                               | Setting Range | Default |
|-------|------------------------------------|---------------|---------|
| n3-23 | Overexcitation Operation Selection | 0 to 2        | 0       |

**Setting 0: Enabled in Both Directions**

**Setting 1: Enabled in Forward Direction Only**

**Setting 2: Enabled in Reverse Direction Only**

## 5.10 o: Operator Related Settings

These parameters concern the various functions and features of the digital operator.

### ◆ o1: Display Settings and Selections

These parameters determine how data is shown on the operator display.

#### ■ o1-01: Drive Mode Unit Monitor Selection

When using an LED operator, pressing the up arrow key on the drive will display the following data: frequency reference → rotational direction → output frequency → output current → o1-01 selection.

Parameter o1-01 selects the content of the last monitor in this sequence. There is no effect like this on an LCD operator.

| No.   | Name                              | Setting Range                      | Default     |
|-------|-----------------------------------|------------------------------------|-------------|
| o1-01 | Drive Mode Unit Monitor Selection | 104 to 904<br>(U1-04 to U9-04) </> | 106 (U1-06) |

<1> U2-□□ and U3-□□ parameters cannot be selected.

To select a monitor parameter, set the three numeric digits that make up that monitor. This is done by entering the □-□□ part of U□-□□.

#### ■ o1-02: User Monitor Selection after Power Up

Selects which monitor parameter will be displayed upon power up. Defaulted to show the frequency reference when the drive is first turned on.

| No.   | Name                                  | Setting Range | Default |
|-------|---------------------------------------|---------------|---------|
| o1-02 | User Monitor Selection after Power Up | 1 to 5        | 1       |

#### Setting 1: Frequency Reference (U1-01)

#### Setting 2: Forward/Reverse

#### Setting 3: Output Frequency (U1-02)

#### Setting 4: Output Current (U1-03)

#### Setting 5: User Selected Monitor (set by o1-01)

Setting 5 displays the monitor selected from the U parameter by o1-01.

#### ■ o1-03: Digital Operator Display Selection

Sets the units used to display the frequency reference and output frequency.

Set this parameter to 3 for user-set units before setting parameters o1-10 and o1-11.

| No.   | Name                               | Setting Range | Default |
|-------|------------------------------------|---------------|---------|
| o1-03 | Digital Operator Display Selection | 0 to 3        | 0       |

#### Setting 0: 0.01 Hz Units

#### Setting 1: 0.01% Units

100% = max output frequency.

#### Setting 2: r/min Units

Calculated by the max output frequency and the number of motor poles.

**Note:** Setting 2 requires entering the number of motor poles to E2-04, E4-04, and E5-04.

#### Setting 3: User-Set Units (use o1-01 and 01-11)

Set the value used for the maximum frequency reference to o1-10, then set the placement of the decimal point in this number to o1-11.

For example, to display the maximum output frequency as “100.00”, set o1-10 to 10000 and o1-11 to 2 (i.e., 10000 with two numbers to the right of the decimal point).

**Note:** Parameter o1-03 allows the programmer to change the units used in the following parameters and monitors:

## 5.10 o: Operator Related Settings

U1-01: Frequency Reference  
U1-02: Output Frequency  
U1-05: Motor Speed  
U1-16: Output Frequency after Soft-Starter (Accel/Decel Ramp Generator)  
d1-01 to d1-17: Frequency References

### ■ o1-05: LCD Contrast Control

Sets the brightness of the optional LCD operator. The lower the setting, the brighter the LCD contrast. The higher the setting, the darker the LCD contrast.

| No.   | Name                 | Setting Range | Default |
|-------|----------------------|---------------|---------|
| o1-05 | LCD Contrast Control | 0 to 5        | 3       |

### ■ o1-06: User Monitor Selection Mode

Select between standard sequential monitors or selectable monitors to be displayed on the 2nd and 3rd lines of the digital operator display.

Use parameters o1-07 and o1-08 to select and fix the second and third monitors shown in the Home (Frequency Reference) and Monitor screen to ensure that those monitors are always visible when scrolling through the monitor list.

| No.   | Name                        | Setting Range | Default |
|-------|-----------------------------|---------------|---------|
| o1-06 | User Monitor Selection Mode | 0, 1          | 0       |

**Setting 0: 3 Mon Sequential (displays the next 2 sequential monitors)**

**Setting 1: 3 Mon Selectable (set by o1-07 and o1-08)**

### ■ o1-07: Second Line User Monitor Selection

Selects the monitor that is shown in the second line. Effective only when o1-06 is set to 1.

Enter the last three digits of the monitor parameter number to be displayed: U□-□□. For example, set “403” to display monitor parameter U4-03.

| No.   | Name                               | Setting Range | Default |
|-------|------------------------------------|---------------|---------|
| o1-07 | Second Line User Monitor Selection | 101 to 799    | 102     |

### ■ o1-08: Third Line User Monitor Selection

Selects the monitor that is shown in the third line. Effective only when o1-06 is set to 1.

Enter the last three digits of the monitor parameter number to be displayed: U□-□□. For example, set “403” to display monitor parameter U4-03.

| No.   | Name                               | Setting Range | Default |
|-------|------------------------------------|---------------|---------|
| o1-08 | Second Line User Monitor Selection | 101 to 904    | 191     |



### ■ o1-09: Frequency Reference Display Units

| No.   | Name                              | Setting Range   | Default |
|-------|-----------------------------------|-----------------|---------|
| o1-09 | Frequency Reference Display Units | 0 to 15; 24, 25 | 25      |

Setting 0: Inch of Water (WC)

Setting 1: Pounds per Square Inch (PSI)

Setting 2: Gallons per Minute (GPM)

Setting 3: Degrees Fahrenheit (F)

Setting 4: Cubic Feet per Minute (CFM)

Setting 5: Cubic Meters per Hour (CMH)

Setting 6: Liters per Hour (LPH)

Setting 7: Liters per Second (LPS)

Setting 8: Bar (Bar)

Setting 9: Pascals (Pa)

Setting 10: Degrees Celsius (C)

Setting 11: Meters (Mtr)

Setting 12: Feet (Ft)

Setting 13: Liters per Minute (LPN)

Setting 14: Cubic Meters per Minute (CMM)

Setting 15: Inches of Mercury (Hg)

Setting 24: Custom Units (determined by o1-13 to o1-15)

Setting 25: None

### ■ o1-10: User-Set Display Units Maximum Value

Determines the display value that is equal to the maximum output frequency. The decimal number is defined by parameter o1-11.

**Note:** This setting changes automatically when o1-03 is changed. o1-10 can only be adjusted when o1-03 is set to 3.

| No.   | Name                                 | Setting Range | Default             |
|-------|--------------------------------------|---------------|---------------------|
| o1-10 | User-Set Display Units Maximum Value | 1 to 60000    | Determined by o1-03 |

### ■ o1-11: User-Set Display Units Decimal Display

Determines the number of digits for user-set display if o1-03 is set to 3. The setting value is equal to the number of decimal places. The maximum display value is defined by o1-10.

**Note:** This setting changes automatically when o1-03 is changed. o1-11 can only be adjusted when o1-03 is set to 3.

| No.   | Name                                   | Setting Range | Default             |
|-------|--|---------------|---------------------|
| o1-11 | User-Set Display Units Decimal Display | 0 to 3        | Determined by o1-03 |

### ■ o1-12: Home Help Text

| No.   | Name           | Setting Range | Default |
|-------|----------------|---------------|---------|
| o1-12 | Home Help Text | 0, 1          | 1       |

Setting 0: Disabled

Setting 1: Enabled

## ◆ o2: Operator Key Selections

These parameters determine the functions assigned to the operator keys.

### ■ o2-02: STOP Key Function Selection

Selects if the STOP key on the digital operator can be used to stop the operation when the drive is controlled from a remote source (i.e., not from digital operator).

## 5.10 o: Operator Related Settings

| No.   | Name                        | Setting Range | Default |
|-------|-----------------------------|---------------|---------|
| o2-02 | STOP Key Function Selection | 0 or 1        | 1       |

### Setting 0: Disabled

The STOP key has no function when the drive is controlled by a source other than the digital operator. The drive can only be stopped from the Run command source that has been selected.

### Setting 1: Enabled

The STOP key can be used to terminate the operation, even if the Run command source is not assigned to the digital operator. If operation has been interrupted by pressing the STOP key, the Run command must be cycled to restart the drive.

## ■ o2-03: User Parameter Default Value

Once drive parameters are set up completely, the values set can be saved as “User Initialization Values” by setting parameter o2-03. Once this has been done, the “Initialize Parameters” parameter (A1-03) will offer the choice of “1110: User Initialize”. Choosing A1-03 = “1110: User Initialize”, will reset all parameters to the values saved as “User Initialization Values”.

| No.   | Name                         | Setting Range | Default |
|-------|------------------------------|---------------|---------|
| o2-03 | User Parameter Default Value | 0 to 2        | 0       |

### Setting 0: No Change

All “User Initialization Values” are saved as they are.

### Setting 1: Set User Initialization Values

The current parameter settings are saved as “User Initialization Values”. After setting o2-03 to 1 and pressing the ENTER key, the values are saved and the display returns to 0.

### Setting 2: Clear User Initialization Values

All “User Initialization Values” are cleared. After setting o2-03 to 2 and pressing the ENTER key, the values are erased and the display returns to 0. A1-03 = 1110 becomes invalid.

## ■ o2-04: Drive Model Selection

Parameter o2-04 matches the control board to the drive hardware. Proper setting of o2-04 is important for optimal performance and proper protection for the drive hardware. This parameter is configured at the factory and does not normally require adjustment in the field. It is available primarily to accommodate control board replacement in the event of damage.

| No.   | Name                  | Setting Range | Default                 |
|-------|-----------------------|---------------|-------------------------|
| o2-04 | Drive Model Selection | -             | Depending on drive size |

- Note:**
1. [Refer to Defaults by Drive Model on page 377](#) for a list of o2-04 settings and parameters that change depending on the drive model selection.
  2. Drive performance will suffer if the correct drive capacity is not set to o2-04, and protective functions will fail to operate properly.
  3. This parameter is not reset to the default value when the drive is initialized using A1-03.

## ■ o2-05: Frequency Reference Setting Method Selection

Determines if the ENTER key must be used to input a frequency reference from the digital operator.

| No.   | Name   | Setting Range | Default |
|-------|--|---------------|---------|
| o2-05 | Frequency Reference Setting Method Selection | 0 or 1        | 0       |

### Setting 0: ENTER Key Required

Every change in the frequency reference setting on the digital operator has to be finalized by pressing the ENTER key before it becomes effective.

### Setting 1: ENTER Key Not Required

The output frequency changes immediately when the reference is changed by the UP and DOWN key on the digital operator. The ENTER key does not need to be pressed. The frequency reference is saved five seconds after the Up or DOWN key has been released. If an undervoltage error (Uv) occurs within 5 seconds of pressing the ENTER key, the frequency reference will not be saved to memory. The digital operator display flashes when settings can be made to the frequency reference.

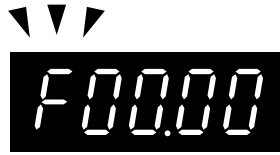


Figure 5.79 Ready to Set Frequency Reference (Standard Digital LED Operator)

### ■ o2-06: Operation Selection when Digital LCD Operator is Disconnected

Determines if the drive will stop when an external LCD operator is removed in LOCAL mode or with b1-02 set to 0.

**Note:** An LCD operator is available as an option. This setting is not applicable to the standard LED operator that comes with the drive.

| No.   | Name                                     | Setting Range | Default |
|-------|--|---------------|---------|
| o2-06 | Digital Operator Disconnection Operation | 0 or 1        | 0       |

#### Setting 0: Continue Operation

The operation is continued.

#### Setting 1: Trigger a Fault

The operation is stopped and an oPr fault is triggered. The motor coasts to stop.

### ■ o2-07: Motor Direction at Power Up when Using Operator

Determines the direction the motor will rotate after the drive is powered up when the Run command is set to be given from the digital operator.

**Note:** This parameter is effective only when the Run command is set to be given from the digital operator (b1-02/16 = 0).

| No.   | Name  | Setting Range | Default |
|-------|---|---------------|---------|
| o2-07 | Motor Direction at Power Up when Using Operator | 0 or 1        | 0       |

#### Setting 0: Forward

#### Setting 1: Reverse

### ■ o2-30: Monitor Position Save

| No.   | Name                  | Setting Range | Default |
|-------|-----------------------|---------------|---------|
| o2-30 | Monitor Position Save | 0, 1          | 0       |

#### Setting 0: Disabled

#### Setting 1: Enabled

### ◆ o3: Copy Function

Use o3 parameters to Read, Copy, and Verify the parameter settings to and from the drive.

#### ■ o3-01: Copy Function Selection

This parameter controls the copying of parameters to and from the LED operator (option). The copy function will change certain parameter default settings depending on the regional specification of the drive.

| No.   | Name                    | Setting Range | Default |
|-------|-------------------------|---------------|---------|
| o3-01 | Copy Function Selection | 0 to 3        | 0       |

#### 0: COPY SELECT (no function)

#### 1: INV --> OP READ

All parameters are copied from the drive to the digital operator.

**Note:** Set o3-02 to 1 to unlock copy protection.

#### 2: OP --> INV WRITE

All parameters are copied from the digital operator to the drive.

## 5.10 o: Operator Related Settings

### 3: OP<-->INV VERIFY

Parameter settings in the drive are compared to those in the digital operator.

**Note:** When using the copy function, the drive model number (o2-04) and the software number (U1-14) must match or an error will occur.

#### ■ o3-02 Copy Allowed Selection

Enables and disables the digital operator copy functions.

| No.   | Name                   | Setting Range | Default |
|-------|------------------------|---------------|---------|
| o3-02 | Copy Allowed Selection | 0, 1          | 0       |

#### 0: Disabled

No digital operator copy functions are allowed

#### 1: Enabled

Copying allowed

## ◆ o4: Maintenance Monitor Settings

### ■ o4-01: Accumulated Operation Time Setting

Parameter o4-01 sets the cumulative operation time and allows the user to set the starting value of the accumulated operation time displayed in monitor U4-01.

**Note:** The value in o4-01 is set in 10 h units. For example, a setting of 30 will set the cumulative operation time counter to 300 h. 300 h will also be displayed in monitor U4-01.

| No.   | Name                               | Setting Range | Default |
|-------|------------------------------------|---------------|---------|
| o4-01 | Accumulated Operation Time Setting | 0 to 9999     | 0       |

### ■ o4-02: Accumulated Operation Time Selection

Selects the conditions for what is to be considered “accumulated operation time.” Accumulated operation time is displayed in U4-01.

| No.   | Name                                 | Setting Range | Default |
|-------|--------------------------------------|---------------|---------|
| o4-02 | Accumulated Operation Time Selection | 0 or 1        | 0       |

#### Setting 0: Power On Time

The drive logs the time it is connected to a power supply, no matter if the motor is running or not.

#### Setting 1: Run Time

The drive logs the time that the output is active, i.e., whenever a Run command is active (even if the motor is not rotating) or a voltage is output.

### ■ o4-03: Cooling Fan Operation Time/Maintenance Setting

Sets the value of the cooling fan operation time counter displayed in monitor U4-03. Parameter o4-03 also sets the base value used for the cooling fan maintenance value displayed in U4-04. Be sure to reset this parameter back to 0 if the cooling fan is replaced.

- Note:**
1. The value in o4-03 is set in 10 h units. For example, a setting of 30 will set the cooling fan operation time counter to 300 h. “300” will be displayed in monitor U4-03.
  2. The actual maintenance time depends on the environment the drive is used in.

| No.   | Name                       | Setting Range | Default |
|-------|----------------------------|---------------|---------|
| o4-03 | Cooling Fan Operation Time | 0 to 9999     | 0       |

### ■ o4-05: Capacitor Maintenance Setting

Sets value of the maintenance monitor for the DC bus capacitors displayed in U4-05 as a percentage of the total expected performance life. This value should be reset to 0 when the DC bus capacitors have been replaced.

**Note:** The actual maintenance time will depend on the environment the drive is used in.

| No.   | Name                          | Setting Range | Default |
|-------|-------------------------------|---------------|---------|
| o4-05 | Capacitor Maintenance Setting | 0 to 150%     | 0%      |

### ■ o4-07: DC Bus Pre-charge Relay Maintenance Setting

Sets the value of the softcharge bypass relay maintenance time displayed in U4-06 as a percentage of the total expected performance life. This value should be reset to 0 when the relay has been replaced.

**Note:** The maintenance actual time depends on the environment the drive is used in.

| No.   | Name  | Setting Range | Default |
|-------|---|---------------|---------|
| o4-07 | DC Bus Pre-charge Relay Maintenance Setting | 0 to 150%     | 0%      |

### ■ o4-09: IGBT Maintenance Setting

Sets the value of the IGBT maintenance time displayed in U4-07 as a percentage of the total expected performance life. This value should be reset to 0 when the IGBTs have been replaced.

**Note:** The actual maintenance time depends on the environment the drive is used in.

| No.   | Name                     | Setting Range | Default |
|-------|--------------------------|---------------|---------|
| o4-09 | IGBT Maintenance Setting | 0 to 150%     | 0%      |

### ■ o4-11: U2, U3 Initialization

When the drive is initialized, the fault trace and fault history monitors (U2-□□ and U3-□□) are not reset. Parameter o4-11 can be used to initialize them.

| No.   | Name                  | Setting Range | Default |
|-------|-----------------------|---------------|---------|
| o4-11 | U2, U3 Initialization | 0 or 1        | 0       |

#### Setting 0: No Action

The drive keeps a record of the fault trace and fault history.

#### Setting 1: Reset Fault Data

Resets the data for the U2-□□ and U3-□□ monitors. Once o4-11 is set to 1 and the ENTER key is pressed, the fault data are erased and the display returns to 0.

### ■ o4-12: kWh Monitor Initialization

The kWh monitors U4-10 and U4-11 are not initialized when the power is cycled or the drive is initialized. o4-12 can be used to manually reset them.

| No.   | Name                       | Setting Range | Default |
|-------|----------------------------|---------------|---------|
| o4-12 | kWh Monitor Initialization | 0 or 1        | 0       |

#### Setting 0: No Action

The kWh data are kept as they are.

#### Setting 1: Reset kWh Data

Resets the kWh counter. The monitors U4-10 and U4-11 will show 0. Once o4-12 is set to 1 and the ENTER key is pressed, the kWh data are erased and the display returns to 0.

### ■ o4-13: Number of Run Commands Counter Initialization

The Run command counter displayed in U4-02 is not reset when the power is cycled or the drive is initialized. Using o4-13 it can be manually reset to 0.

| No.   | Name                                 | Setting Range | Default |
|-------|--------------------------------------|---------------|---------|
| o4-13 | Number of Run Commands Counter Reset | 0 or 1        | 0       |

#### Setting 0: No Action

The Run command data are kept as they are.

#### Setting 1: Reset Run Commands Counter

Resets the Run commands counter. The monitor U4-02 will show 0. Once o4-13 is set to 1 and the ENTER key is pressed, the counter value is erased and the display returns to 0.

## 5.10 o: Operator Related Settings

---

### ■ o4-17: Real-Time Clock Setting

| No.   | Name                      | Setting Range | Default |
|-------|---------------------------|---------------|---------|
| o4-17 | Set/Reset Real-Time Clock | 0 to 2        | 0       |

#### Setting 0: — —

No Setting (Default)

#### Setting 1: Set

When o4-17 is set to 1, the digital operator will show the Clock Adjustment display. In Clock Adjustment Mode the user can adjust the Real-Time Clock.

#### Setting 2: Reset

When o4-17 is set to 2, the Real-Time Clock data is cleared. A TIM fault will occur until o4-17 is set to 1 and the Real-Time Clock is set.

### ■ o4-20: Time Display Format

| No.   | Name                | Setting Range | Default |
|-------|---------------------|---------------|---------|
| o4-20 | Time Display Format | 0, 1          | 0       |

Sets the time display format.

#### Setting 0: 12-Hour

#### Setting 1: 24-Hour

## 5.11 P: Pump

### ◆ P1: Pump Basic

#### ■ P1-01: Pump Mode

Selects the base operation mode of the drive controller.

| No.   | Parameter Name | Setting Range | Default |
|-------|----------------|---------------|---------|
| P1-01 | Pump Mode      | 0, 3          | 0       |

##### Setting 0: Drive only

Designed for single pump stand-alone applications

##### Setting 3: MEMOBUS network

Up to eight drives can be networked together to provide for system redundancy and precise control.

Staging is disabled when and the drive PID output is influenced by the Water Level / Suction Pressure Control.

The functions listed below will behave slightly different when P1-01 is set to 3:

- **Start Level:** Active on the first pump in the network. Drives in the process of alternation will not undergo this process.
- **Sleep:** Active when the drive is the only drive running on the network.
- **Over-cycle Protection:** Active when the drive is the only drive running on the network.
- **Pre-charge:** Active only on the first drive to run in the network.
- **Low City Pressure:** Active on any drive in the network. An alarm condition will cause other drives in the network to stop running and show a “Net Pump Err” message.
- **Utility Delay:** When this function is active, the drive is unavailable to the iQpump MEMOBUS Network and will force the Home Screen text to show “Pump Off Network”.
- **Remote Drive Disable:** When this function is active, the drive is unavailable to the iQpump MEMOBUS Network and will force the Home Screen text to show “Pump Off Network”.

#### ■ P1-02: System Units

Selects the base unit in which most drive PID setpoints, scaling, monitors, limits, and faults/alarm levels will be set.

**Note:** Set this parameter prior to changing other parameters, as internal scaling is based on P1-02.

| No.   | Parameter Name | Setting Range | Default |
|-------|----------------|---------------|---------|
| P1-02 | System Units   | 0 to 10       | 1       |

##### Setting 0: No unit

##### Setting 1: PSI: Pounds per square inch

##### Setting 2: Pa: Pascals

##### Setting 3: Bar: Bar

##### Setting 4: "WC: Inch of water

##### Setting 5: "Hg: Inch of Mercury

##### Setting 6: ft: feet

##### Setting 7: m: meters

##### Setting 8: °F: Degrees Fahrenheit

##### Setting 9: °C: Degrees Celsius

##### Setting 10: Percent

#### ■ P1-03: Feedback Device Scaling

Sets the feedback device scaling used for the PID controller. This information can be found on the nameplate or specification sheet and is usually expressed as the maximum output of the device.

For example, a pressure sensor scaling might be 145.0 PSI at 20 mA output and would require setting P1-03 to 145.0 PSI.

**Note:** Set this parameter prior to changing other parameters related to the PID feedback, as internal scaling is based on P1-03.

| No.   | Parameter Name          | Setting Range | Default   |
|-------|-------------------------|---------------|-----------|
| P1-03 | Feedback Device Scaling | 0.1 to 6000.0 | 145.0 PSI |

## 5.11 P: Pump

### ■ P1-04: Start / Draw Down Level

Sets the wake up level from the Sleep function. This setting is dependent on whether PID is normal or inverse acting (b5-09). When the drive is asleep and the PID feedback signal rises above (normal acting) or falls below (inverse acting) this setting for the time set in P1-05, Start Level Delay Time, the drive will wake up.

| No.   | Parameter Name          | Setting Range   | Default |
|-------|-------------------------|-----------------|---------|
| P1-04 | Start / Draw Down Level | -999.9 to 999.9 | 0.0 PSI |

### ■ P1-05: Start Level Delay Time

Sets the delay time for waking the drive to prevent accidental wake up caused by erratic feedback.

| No.   | Parameter Name         | Setting Range | Default |
|-------|------------------------|---------------|---------|
| P1-05 | Start Level Delay Time | 0 to 3600 s   | 1 s     |

### ■ P1-06: Minimum Pump Speed

Sets the minimum speed at which the drive will run the pump. Most pumps cannot run at low speeds due to cavitation, so be sure to consult the pump specification sheet for the minimum safe run speed.

| No.   | Parameter Name     | Setting Range | Default |
|-------|--------------------|---------------|---------|
| P1-06 | Minimum Pump Speed | 0.0 to E1-04  | 40.0 Hz |

### ■ P1-07: Minimum Pump Speed Units

Sets the units, range, and resolution for parameter P1-06. Changing P1-07 resets P1-06 to the default value.

| No.   | Name                     | Setting Range | Default |
|-------|--------------------------|---------------|---------|
| P1-07 | Minimum Pump Speed Units | 0, 1          | 0       |

#### Setting 0: Hz

Forces a default value of 40.0 Hz for P1-06.

#### Setting 1: RPM

Forces a default value of 1800 RPM (VTC) and 2400 RPM (all others) for P1-06.

### ■ P1-08: Low Feedback Level

Sets the level at which a Low Feedback alarm or fault will occur. When the PID feedback falls below the P1-08 setting for the time set in P1-09, the drive will respond based on the setting in P1-10.

| No.   | Parameter Name     | Setting Range | Default |
|-------|--------------------|---------------|---------|
| P1-08 | Low Feedback Level | 0.0 to 6000.0 | 0.0 PSI |

### ■ P1-09: Low Feedback Level Fault Delay Time

Sets the delay time after which a Low Feedback alarm or fault will occur. When the PID feedback falls below the P1-08 setting for the time set in P1-09, the drive will respond based on the setting in P1-10.

| No.   | Parameter Name                      | Setting Range | Default |
|-------|-------------------------------------|---------------|---------|
| P1-09 | Low Feedback Level Fault Delay Time | 0 to 3600 s   | 10 s    |

### ■ P1-10: Low Feedback Selection

Selects the drive response to a Low Feedback condition. When the PID feedback falls below the P1-08 setting for the time set in P1-09, the drive will respond based on the setting in P1-10.

| No.   | Parameter Name         | Setting Range | Default |
|-------|------------------------|---------------|---------|
| P1-10 | Low Feedback Selection | 0 to 2        | 0       |

Low feedback detection is enabled when:

- P1-08 > 0.0
- Drive is running in AUTO Mode, including sleep boost and feedback drop detection (standard PID, b5-09 = 0)
- Run Command is present (including sleep and timer operation) (inverse PID, b5-09 = 1)



**Setting 0: Fault**

When feedback drops below the P1-08 level for longer than the time set in P1-09, the drive will fault on the “LFB – Low Feedback” fault and coast to a stop.

The digital output programmed to “Low Feedback” (H2-0□ = 97) closes. The drive will also display the “Low Feedback – Low FB Sensed” alarm. The digital output will remain closed until the fault is reset.

**Setting 1: Alarm**

When feedback drops below the P1-08 level for longer than the time set in P1-09, the digital output programmed to “Low Feedback” (H2-0□ = 97) closes and the drive displays the “Low Feedback – Low FB Sensed” alarm.

When feedback rises above the level determined by P1-08 and P1-14, or when one or more of the conditions that enable low feedback detection are no longer true, the digital output will open and the alarm will clear.

**Setting 2: Digital out only**

When feedback drops below the P1-08 level for longer than the time set in P1-09, the digital output programmed to “Low Feedback” (H2-0□ = 97) closes.

When feedback rises above the level determined by P1-08 and P1-14, or when one or more of the conditions that enable low feedback detection are no longer true, the digital output will open.

**■ P1-11: High Feedback Level**

Sets the level at which a High Feedback alarm or fault will occur. When the PID feedback rises above the P1-11 setting for the time set in P1-12, the drive will respond based on the setting in P1-13.

| No.   | Parameter Name      | Setting Range | Default   |
|-------|---------------------|---------------|-----------|
| P1-11 | High Feedback Level | 0.0 to 6000.0 | 155.0 PSI |

**■ P1-12: High Feedback Level Fault Delay Time**

Sets the delay time after which a Low Feedback alarm or fault will occur. When the PID feedback rises above the P1-11 setting for the time set in P1-12, the drive will respond based on the setting in P1-13.

| No.   | Parameter Name                       | Setting Range | Default |
|-------|--------------------------------------|---------------|---------|
| P1-12 | High Feedback Level Fault Delay Time | 0 to 3600 s   | 5 s     |

**■ P1-13: High Feedback Selection**

Selects the drive response to a High Feedback condition. When the PID feedback rises above the P1-11 setting for the time set in P1-12, the drive will respond based on the setting in P1-13.

| No.   | Parameter Name          | Setting Range | Default |
|-------|-------------------------|---------------|---------|
| P1-13 | High Feedback Selection | 0 to 2        | 0       |

High feedback detection is enabled when:

- P1-11 > 0
- Run Command present, including sleep & timer operation (standard PID, b5-09 = 0)
- Drive is running in AUTO Mode, including feedback drop detection (inverse PID, b5-09 = 1).

**Setting 0: Fault**

When feedback rises above the P1-11 for longer than the time set in P1-12, the drive will fault on the “HFB – High Feedback” fault and coast to a stop.

The digital output programmed to “High Feedback” (H2-0□ = 96) closes. The drive will also display the “High Feedback – High FB Sensed” alarm. The digital output will remain closed until the fault is reset.

**Setting 1: Alarm**

When feedback rises above the P1-11 for longer than the time set in P1-12, the digital output programmed to “High Feedback” (H2-0□ = 96) closes and the drive displays the “High Feedback – High FB Sensed” alarm.

When feedback falls below the level determined by P1-11 and P1-14, or when one or more of the conditions that enable high feedback detection are no longer true, the digital output will open and the alarm will clear.

**Setting 2: Digital out only**

When feedback rises above the P1-11 for longer than the time set in P1-12, the digital output programmed to “High Feedback” (H2-0□ = 96) closes.

## 5.11 P: Pump

When feedback falls below the level determined by P1-11 and P1-14, or when one or more of the conditions that enable high feedback detection are no longer true, the digital output will open.

### ■ P1-14: Hysteresis Level

Sets the hysteresis level used for low and high feedback detection.

| No.   | Name             | Setting Range | Default |
|-------|------------------|---------------|---------|
| P1-14 | Hysteresis Level | 0.0 to 100.0  | 0.0 PSI |

### ■ P1-15: Maximum Setpoint Difference

When the system is running and the difference between the setpoint and feedback exceeds the level set in P1-15 for the time set in P1-16, the drive will respond according to the method selected in P1-17. On fault, the drive will coast to stop.

Setting this parameter to 0.0 disables the function. This function is active only when running while in AUTO Mode. When P1-01 is set to 3, the function is active on the lead drive and will stop all drives running on the network when the NMS fault occurs (system fault).

| No.   | Name                        | Setting Range | Default |
|-------|-----------------------------|---------------|---------|
| P1-15 | Maximum Setpoint Difference | 0.0 to 6000.0 | 0.0 PSI |

### ■ P1-16: Not Maintaining Setpoint Time

Sets the delay time before a “Setpoint Not Met” condition occurs. Pump protection criteria specified in P1-15 must be met before the timer will start. Setting P1-15 to 0 disables NMS detection.

| No.   | Name                          | Setting Range | Default |
|-------|-------------------------------|---------------|---------|
| P1-16 | Not Maintaining Setpoint Time | 0 to 3600 s   | 60 s    |

### ■ P1-17: Not Maintaining Setpoint Selection

| No.   | Name                               | Setting Range | Default |
|-------|------------------------------------|---------------|---------|
| P1-17 | Not Maintaining Setpoint Selection | 0 to 2        | 0       |

#### Setting 0: Fault

The “NMS – Setpoint Not Met” alarm is shown on the HOA keypad and the digital output closes when the PID feedback rises above or falls below the setpoint for more than the P1-15 amount.

When the feedback returns to a value within the P1-15 setting before the Not Maintaining Set Point Time (P1-16) expires, the alarm clears, the digital output opens, and the timer resets. If the NMS condition persists for longer than the time set in P1-16, the drive will fault out on a “NMS – Setpoint Not Met” fault and coast to a stop. The digital output remains closed until the fault is reset.

#### Setting 1: Alarm

The “NMS – Setpoint Not Met” alarm is shown on the HOA keypad and the digital output closes when the PID feedback rises above or falls below the setpoint more than the P1-15 amount.

When the feedback returns to a value within the P1-15 level, the alarm clears and the digital output opens.

#### Setting 2: Digital out only

A digital output programmed to 93 closes. When the feedback returns to a value within the P1-15 level, the digital output opens.

### ■ P1-18: Prime Loss Detection Method

| No.   | Name                        | Setting Range | Default |
|-------|-----------------------------|---------------|---------|
| P1-18 | Prime Loss Detection Method | 0 to 2        | 0       |

Loss of Prime (LOP) is enabled when one of the following conditions are true:

- P1-19 > 0 in AUTO Mode and Sleep Boost
- P4-05 > 0 in Pre-Charge 1 Mode
- P4-08 > 0 in Pre-Charge 2 Mode
- P5-06 > 0 in HAND Mode
- P5-07 > 0 in HAND Mode 2

- b5-14 > 0 in Wire Break (Run at Fixed Speed Mode)

The drive detects an LOP condition when the output frequency rises above the LOP detection frequency, and the measured quantity (current, power, or torque) falls below the LOP detection level.

When the condition is detected for longer than the time set in P1-20, Prime Loss Time, the drive will respond according to the P1-22, Prime Loss Selection, setting.

#### Setting 0: Current (A)

U1-03, Output Current, is compared against LOP detection level parameters P1-19, P4-05, P4-08, P5-06, P5-07, and b5-14. The unit text of the LOP Detection Level parameters is A (Amps).

#### Setting 1: Power (kW)

U1-08, Output Power, is compared against LOP detection level parameters P1-19, P4-05, P4-08, P5-06, P5-07, and b5-14. The unit text of the LOP Detection Level parameters is kW.

#### Setting 2: Torque (%)

The drive calculated torque (U6-01, Motor Secondary Current (Iq in V/f) is compared against LOP detection level parameters P1-19, P4-05, P4-08, P5-06, P5-07, and b5-14. The unit text of the LOP Detection Level parameters is percentage (%).

### ■ P1-19: Prime Loss Level

Detects loss of prime in the pump when in AUTO or Sleep Boost mode. If the measured quantity determined by P1-18 drops below this level for the time specified in P1-20 and the output frequency is above the level determined by P1-21, a “Loss Of Prime” condition occurs. The drive will respond to the “Loss Of Prime” condition based on the P1-22 setting.

| No.   | Name             | Setting Range   | Default |
|-------|------------------|-----------------|---------|
| P1-19 | Prime Loss Level | 0.0 to 1000.0 A | 0.0 A   |

### ■ P1-20: Loss of Prime Time

Sets the delay time before a “Loss of Prime” condition occurs. The pump protection criteria specified in P1-18 and P1-19 must be met before the timer will start.

| No.   | Name               | Setting Range | Default |
|-------|--------------------|---------------|---------|
| P1-20 | Loss of Prime Time | 0 to 600 s    | 20 s    |

### ■ P1-21: Loss of Prime Frequency

If P1-21 is set to a non-zero value, when the drive is operating above the frequency set in this parameter, the “Loss Of Prime” detection is enabled. If this parameter is set to zero, the frequency level will be determined by the smaller value between (Fmax - 1 Hz) and (d2-01 - 1 Hz).

| No.   | Name                    | Setting Range  | Default |
|-------|-------------------------|----------------|---------|
| P1-21 | Loss of Prime Frequency | 0.0 to [E1-04] | 0.0 Hz  |

### ■ P1-22: Loss of Prime Selection

Determines drive response to a “Loss Of Prime” condition.

| No.   | Name                    | Setting Range | Default |
|-------|-------------------------|---------------|---------|
| P1-22 | Loss of Prime Selection | 0 to 2        | 0       |

#### Setting 0: Fault

#### Setting 1: Alarm

#### Setting 2: Digital out only

### ■ P1-23: Loss of Prime Maximum Restart Time

If the Loss of Prime fault restart fails (or is not attempted due to a continuing fault condition), the drive will wait for the time set in P1-23 before attempting another restart.

**Note:** This parameter will take the place of L5-04 during a Loss of Prime fault restart attempt.

| No.   | Name                               | Setting Range     | Default |
|-------|------------------------------------|-------------------|---------|
| P1-23 | Loss of Prime Maximum Restart Time | 0.2 to 6000.0 min | 0.2 min |

## 5.11 P: Pump

### ■ P1-24: Level at Full Speed

Sets the level used to override the P-gain and I-limit with a calculated value based on Sleep level, Wakeup level, Minimum Pump Speed, Transducer Scaling, and Maximum Frequency. This feature is disabled when set to 0.0.

| No.   | Name                | Setting Range | Default |
|-------|---------------------|---------------|---------|
| P1-24 | Level at Full Speed | 0.0 to 6000.0 | 0.0     |

### ■ P1-30: Low Water Digital Input Configuration

The low water level digital input can indicate when a low water (low level or low pressure) condition exists and fault out the drive. The “Low Water Level” fault is only active when the drive is in an AUTO run state, including sleep boost and feedback drop detection. The fault is not active in all other modes (Sleep, HAND Mode, Pre-Charge, Run at Wire Break, and Sleep).

The low water level digital input can also indicate the end of the Pre-Charge function. The Pre-Charge runs until the low water indication is no longer active.

| No.   | Name                                  | Setting Range | Default |
|-------|---------------------------------------|---------------|---------|
| P1-30 | Low Water Digital Input Configuration | 0, 1          | 0       |

#### Setting 0: Normally open

Closing the switch during an AUTO Mode run triggers the “LWL – Low Water Level” fault and the drive coasts to a stop. Pre-Charge continues while the switch is closed and ends when it opens.

#### Setting 1: Normally closed

Opening the switch during an AUTO mode run triggers the “LWL – Low Water Level” fault and the drive coasts to a stop. Pre-Charge continues while the switch is open and ends when it closes.

### ■ P1-31: High Water Digital Input Configuration

The high water level digital input indicates if a high water (high level or pressure) condition exists and faults out the drive. The “High Water Fault” is only active when the drive is running the pump. The fault is not active when the drive is stopped or sleeping.

| No.   | Name                                   | Setting Range | Default |
|-------|--|---------------|---------|
| P1-31 | High Water Digital Input Configuration | 0, 1          | 0       |

#### Setting 0: Normally open

Closing the switch while the drive is running will trigger the “HWL – High Water Level” fault and the drive will coast to a stop.

#### Setting 1: Normally closed

Opening the switch while the drive is running will trigger the “HWL – High Water Level” fault and the drive will coast to a stop.

## ◆ P2: Pump Protection

### ■ P2-01: Sleep Level Type

Selects which data source the drive will use to determine if it should activate the sleep function. This parameter is application-dependent and should be set in conjunction with the type of system data is available. Choose the data type that best represents a low-activity condition for the system.

**Note:** Set this parameter prior to changing other parameters related to the Sleep Function, as internal scaling is based on P2-01.

| No.   | Parameter Name   | Setting Range | Default |
|-------|------------------|---------------|---------|
| P2-01 | Sleep Level Type | 0 to 3        | 0       |

#### Setting 0: Output frequency

#### Setting 1: Output current

#### Setting 2: Feedback

#### Setting 3: Output speed (RPM)

### ■ P2-02: Sleep Level

Sets the level at which the drive will enter sleep mode. The drive will enter sleep mode when the monitored data falls below the P2-02 setting for the time set in P2-03.

| No.   | Parameter Name | Setting Range | Default |
|-------|----------------|---------------|---------|
| P2-02 | Sleep Level    | 0.0 to 6000.0 | 0.0 Hz  |

### ■ P2-03: Sleep Delay Time

Sets the delay time after which the drive will enter sleep mode. The drive will enter sleep mode when the monitored data falls below the P2-02 setting for the time set in P2-03.

| No.   | Parameter Name   | Setting Range | Default |
|-------|------------------|---------------|---------|
| P2-03 | Sleep Delay Time | 0 to 3600 s   | 5 s     |

### ■ P4-01: Pre-Charge Level

Sets the level at which the drive will activate the pre-charge function. At start, if the PID is below the P4-01 setting, the drive will run at the P4-02 frequency setting for the time set in P4-03. PID control is delayed until the Pre-charge function stops. The drive will exit the pre-charge function early if the feedback rises above the P4-01 setting or if a Low Water digital input switch (H1-□□ = 8F) deactivates. Pre-charge is useful to slowly fill or pressurize a system.

| No.   | Parameter Name   | Setting Range | Default |
|-------|------------------|---------------|---------|
| P4-01 | Pre-Charge Level | 0.0 to 6000.0 | 0.0 PSI |

### ■ P4-02: Pre-Charge Frequency

Sets the frequency at which the pre-charge function will run.

| No.   | Parameter Name       | Setting Range | Default |
|-------|----------------------|---------------|---------|
| P4-02 | Pre-Charge Frequency | 0.0 to E1-04  | 0.0 Hz  |

### ■ P4-03: Pre-Charge Time

Sets the duration of time that the Pre-Charge function will run.

| No.   | Parameter Name  | Setting Range     | Default |
|-------|-----------------|-------------------|---------|
| P4-03 | Pre-Charge Time | 0.0 to 3600.0 min | 0.0 min |

The following conditions must be met to enter Pre-Charge Mode:

- Drive Ready or Sleeping (Run command, not faulted, not in program mode)
- NOT in HAND Mode
- “Disable Pre-charge” digital input NOT closed
- P4-03 > 0.0
- If P4-01, Pre-Charge Level, is greater than 0, the PID feedback must be below the P4-01 level. (Forward acting PID, b5-09 = 0, Reverse acting PID, b5-09 = 1).

When the drive enters Pre-Charge Mode 1 and 2, the drive runs at the Pre-Charge frequency set in P4-02/P4-06, the PID controller is disabled and the Pre-Charge digital output (H2-0□ = A4) closes.

When pre-charge is active, the message “Pre Chg Mode Exit in Xsec” appears on the keypad to show how long before pre-charge exits via timers (P4-03 + P4-07).

Additionally, during Pre-Charge Mode:

- When Pre-charge Level 2 (P4-32) is set to 0, the system can exit Pre-charge when the PID Feedback goes above the Pre-charge Level (P4-01) in normal PID operation, or below the P4-01 level in inverse PID operation.

However, when Pre-charge Level 2 (P4-32) is set to a non-zero value, the system goes into Pre-Charge 2 instead when Pre-Charge 1 completes via timer (P4-03) or level (P4-01). At this point, the drive will run at Pre-charge Frequency 2 (P4-06).

The system can exit Pre-charge 2 when the PID Feedback goes above the Pre-charge Level 2 (P4-32) in normal PID operation, or below the P4-32 level in inverse operation.

- When P4-02, Pre-Charge Frequency, or P4-06, Pre-Charge Frequency 2, are set to a value less than P1-06, Minimum Pump Speed, the alarm “Freq. Ref < Pump Min P1-06” is displayed and the drive runs at the minimum speed.
- When Pre-Charge Loss of Prime parameters P4-05 and P4-08 are set to 0, the Loss of Prime detection is disabled.
- When Pre-Charge Loss of Prime parameters P4-05 or P4-08 are set to a value greater than 0, Loss of Prime detection will operate after the output speed reaches the Pre-Charge Frequency set in P4-02 or P4-06.
- The “Low Water” fault (H1-0□ = 8F) is disabled.

## 5.11 P: Pump

- The “Low Feedback” fault is disabled when forward-acting PID is selected (b5-09 = 0) and the “High Feedback” fault is disabled when reverse-acting PID is selected (b5-09 = 1).
- The “Not Maintaining Setpoint” fault is disabled.
- The “Feedback Loss” detection (4 to 20 mA wire break) is enabled, however, the Pre-Charge frequencies will override and the b5-13 “feedback loss goto speed”.

The drive will always exit Pre-Charge Mode when Pre-Charge times P4-03 and P4-07 have expired. The drive will also exit Pre-Charge Mode when one of the following conditions are met:

- P4-03 and P4-32 are set to 0.0
- The “Disable Pre-Charge” digital input (H1-0□ = 8C) closes.
- A digital input programmed to “Low Water” (H1-0□ = 8F) is deactivated (open when P1-30 = 0 or closed when P1-30 = 1).
- The PID feedback satisfies both Pre-charge levels 1 and 2 (all must be true):
  - Pre-charge timers P4-03 and P4-07 have NOT expired
  - PID is enabled (b5-01 > 0).
  - PID is NOT disabled via digital input
  - Pre-Charge Level Set (P4-01 > 0) (and if used, P4-32 > 0)
  - Feedback is greater than Pre-Charge Level (P4-01) and Pre-charge Level 2 (P4-32) (forward-acting PID, b5-09 = 0) or less than Pre-Charge Levels 1 and 2 (reverse-acting PID, b5-09 = 1)
  - Drive is NOT in a “Feedback Loss” condition (4 to 20 mA wire-break detection).

### ■ P2-04: Sleep Activate Level

When P2-01, Sleep Level Type, is set to 0 (Output Frequency / Speed), the Sleep function activates when the output frequency is greater or equal to the level set in P2-04. When P2-04 is programmed to 0.0, the Sleep function activates above P2-02, Sleep Level.

| No.   | Name                 | Setting Range | Default |
|-------|----------------------|---------------|---------|
| P2-04 | Sleep Activate Level | 0.0 to 6000.0 | 0.0 Hz  |

### ■ P2-05: Sleep Boost Level

Sets the amount of boost applied to the setpoint prior to going to sleep. A setting of 0.0 disables the sleep boost function.

| No.   | Name              | Setting Range | Default |
|-------|-------------------|---------------|---------|
| P2-05 | Sleep Boost Level | 0.0 to 6000.0 | 0.0 PSI |

### ■ P2-06: Sleep Boost Hold Time

Sets the amount of time the boosted pressure will be maintained before the drive goes to sleep.

| No.   | Name                  | Setting Range  | Default |
|-------|-----------------------|----------------|---------|
| P2-06 | Sleep Boost Hold Time | 0.5 to 160.0 s | 5.0 s   |

### ■ P2-07: Sleep Boost Maximum Time

Sets the amount of time the system (feedback) has to reach the boosted setpoint. The drive goes to sleep when the amount of time set in P2-07 is exceeded.

| No.   | Name                     | Setting Range  | Default |
|-------|--------------------------|----------------|---------|
| P2-07 | Sleep Boost Maximum Time | 0.5 to 160.0 s | 5.0 s   |

### ■ P2-08: Delta Sleep Feedback Drop Level

When the drive enters sleep mode, the software monitors the feedback to detect a flow-no flow condition. When the PID error (setpoint minus feedback) exceeds the level set in P2-08 within the time set in P2-09 and the output frequency exceeds the P1-06 setting, the sleep operation deactivates and the drive returns to normal operation.

| No.   | Name                            | Setting Range | Default |
|-------|---------------------------------|---------------|---------|
| P2-08 | Delta Sleep Feedback Drop Level | 0.0 to 6000.0 | 0.0 PSI |

### ■ P2-09: Feedback Detection Drop Time

Sets the time window in which the software monitors the feedback to detect a flow-no flow condition using parameter P2-08.

| No.   | Name                         | Setting Range   | Default |
|-------|------------------------------|-----------------|---------|
| P2-09 | Feedback Detection Drop Time | 0.0 to 3600.0 s | 10.0 s  |

### ■ P2-10: Sleep Mode: Cycling Protection

Sets the maximum number of cycles allowed within the time specified in P2-11 before system faults on a PCF “Pump Cycle Fault”.

One cycle is defined as when the drive transfers from normal operation to sleep mode while in AUTO Mode.

A value of 0 disables this function. If P1-01 is set to 3, the function is active when there is only one drive running in the network.

| No.   | Name                           | Setting Range | Default |
|-------|--------------------------------|---------------|---------|
| P2-10 | Sleep Mode: Cycling Protection | 0 to 10       | 0       |

### ■ P2-11: Sleep Mode: Maximum Cycling Protection Time

Sets the maximum time allowed between cycles. When no cycling occurs within the time programmed in P2-11, the drive will decrease the internal cycle register.

| No.   | Name  | Setting Range | Default |
|-------|---|---------------|---------|
| P2-11 | Sleep Mode: Maximum Cycling Protection Time | 0 to 3600 s   | 300 s   |

### ■ P2-12: Over Cycling Mode

Selects the mode and response to an over-cycling condition.

| No.   | Name              | Setting Range | Default |
|-------|-------------------|---------------|---------|
| P2-12 | Over Cycling Mode | 0 to 3        | 0       |

Setting 0: Disabled

Setting 1: Alarm

Setting 2: Fault

Setting 3: Auto SP Compensation

### ■ P2-13: Setpoint Compensation

Sets the amount the drive will increase the setpoint after each over-cycle in an effort to stop the drive from sleeping too often.

When P2-12 is set to 3 (Auto SP Compensation), the software automatically adjusts the setpoint when over-cycling is detected.

| No.   | Name                  | Setting Range | Default |
|-------|-----------------------|---------------|---------|
| P2-13 | Setpoint Compensation | 0.0 to 6000.0 | 0.0 PSI |

### ■ P2-14: Maximum Setpoint Compensation

Sets the maximum allowed setpoint compensation for the Auto Setpoint Compensation mode (P2-12 = 3).

| No.   | Name                          | Setting Range | Default |
|-------|-------------------------------|---------------|---------|
| P2-14 | Maximum Setpoint Compensation | 0.0 to 6000.0 | 0.0 PSI |

### ■ P2-23: Anti-No-Flow Bandwidth

Sets the amount of PI “Error” bandwidth used to detect the no-flow condition. Operation can become less stable if this value is set too high. A setting of 0.00% disables this feature.

| No.   | Name                   | Setting Range | Default |
|-------|------------------------|---------------|---------|
| P2-23 | Anti-No-Flow Bandwidth | 0.00 to 2.00% | 0.40%   |

### ■ P2-24: Anti-No-Flow Detection Time

Sets the time delay after Anti-No-Flow is detected before the drive begins an increased deceleration rate.

## 5.11 P: Pump

| No.   | Name                        | Setting Range | Default |
|-------|-----------------------------|---------------|---------|
| P2-24 | Anti-No-Flow Detection Time | 1.0 to 60.0 s | 10.0 s  |

### ■ P2-25: Anti-No-Flow Release Level

Sets the amount below the setpoint that the feedback must drop after the Anti-No-Flow activates to disengage the Anti-No-Flow and return to normal PI operation.

| No.   | Name                       | Setting Range | Default |
|-------|----------------------------|---------------|---------|
| P2-25 | Anti-No-Flow Release Level | 0.0 to 100.0  | 3.0 PSI |

## ◆ P4: Pump Advanced

### ■ P4-05: Pre-Charge Loss of Prime Level

Sets the level used to detect loss of prime in the pump.

| No.   | Name                           | Setting Range | Default |
|-------|--------------------------------|---------------|---------|
| P4-05 | Pre-Charge Loss of Prime Level | 0.0 to 1000.0 | 0.0 A   |

If the measured quantity set in P1-18 drops below the level set in P4-05 for the time specified in P1-20 and the output frequency is at the P4-02 level, a “Loss Of Prime” condition occurs. The drive will respond to the “Loss Of Prime” condition based on P1-22 setting.

### ■ P4-06: Pre-Charge Frequency 2

Sets the frequency reference used when the Pre-Charge 2 function is active. A value of 0.00 disables this function.

| No.   | Name                   | Setting Range  | Default |
|-------|------------------------|----------------|---------|
| P4-06 | Pre-Charge Frequency 2 | 0.0 to [E1-04] | 0.0 Hz  |

### ■ P4-07: Pre-Charge Time 2

Sets the amount of time the drive will spend at the P1-06 Pre-Charge Frequency 2 speed during Pre-Charge 2. A value of 0.0 disables this function.

| No.   | Name              | Setting Range     | Default |
|-------|-------------------|-------------------|---------|
| P4-07 | Pre-Charge Time 2 | 0.0 to 3600.0 min | 0.0 min |

### ■ P4-08: Pre-Charge Loss of Prime Level 2

Sets the level used to detect loss of prime in the pump.

| No.   | Name                             | Setting Range | Default |
|-------|----------------------------------|---------------|---------|
| P4-08 | Pre-Charge Loss of Prime Level 2 | 0.0 to 1000.0 | 0.0 A   |

If the measured quantity set in P1-18 drops below the level set in P4-08 for the time specified in P1-20 and the output frequency is at the P4-06 level, a “Loss Of Prime” condition occurs. The drive will respond to the “Loss Of Prime” condition based on P1-22 setting.

### ■ P4-10: AUTO Mode Operator Run Power Down Storage

Selects drive response to power loss with regards to the Run command. When running in AUTO Mode and using a Run command from the keypad (b1-02 = 0), P4-10 determines whether the drive will automatically start running when power is reapplied. The factory setting of this parameter requires pressing the AUTO key to start the drive after power loss.

**WARNING!** *Sudden Movement Hazard. If the drive is running at power loss, it will automatically initiate an internal Run command upon power-up if P4-10 = 1 (Enabled) and could result in death or serious injury from moving equipment.*

| No.   | Parameter Name                            | Setting Range | Default |
|-------|---|---------------|---------|
| P4-10 | AUTO Mode Operator Run Power Down Storage | 0, 1          | 0       |

Setting 0: Disabled

Setting 1: Enabled

### ■ P4-11: Thrust Bearing Acceleration Time

Setst he amount of time that the drive will accelerate from 0 speed to the value set in P4-12.



| No.   | Name                             | Setting Range  | Default |
|-------|----------------------------------|----------------|---------|
| P4-11 | Thrust Bearing Acceleration Time | 0.0 to 600.0 s | 1.0 s   |

While this parameter is active, the drive will display the message “Thrust Mode – Thrust Active” on the keypad and the digital output associated with thrust mode (H2-0□ = A9) will close. For output frequencies above P4-12, the drive standard acceleration rates will apply and the message and digital output will clear. When this parameter is set to 0.0, the drive will use the standard acceleration rate.

### ■ P4-12: Thrust Bearing Frequency

Sets the frequency used by the drive when determining which acceleration and deceleration time to use. The Thrust Bearing function is used for applications using submersible motors. The function provides an alternate acceleration time (P4-11) and deceleration time (P4-13) for protecting the pump bearings.

At start, the drive will use the P4-11 acceleration time until the P4-12 frequency is reached, at which time it will use the active C1-□□ acceleration and deceleration times. At stop, if the output frequency is above the P4-12 setting, the active C1-□□ deceleration time will be used until the P4-12 setting is reached at which time it will use the P4-13 time setting for the rest of deceleration.

If P4-12 is set greater than P1-06 (minimum Pump Speed), P4-12 will become the frequency lower limit. The drive PID control must be disabled (b5-01 = 0) for this function to work.

| No.   | Parameter Name           | Setting Range | Default |
|-------|--------------------------|---------------|---------|
| P4-12 | Thrust Bearing Frequency | 0.0 to E1-04  | 30.0 Hz |

### ■ P4-13: Thrust Bearing Deceleration Time

Specifies the amount of time that the drive will decelerate from the value set in P4-12 until reaching 0.

| No.   | Name                             | Setting Range  | Default |
|-------|----------------------------------|----------------|---------|
| P4-13 | Thrust Bearing Deceleration Time | 0.0 to 600.0 s | 5.0 s   |

While this parameter is active, the drive will display the message “Thrust Mode – Thrust Active” on the keypad and the digital output associated with thrust mode (H2-0□ = A9) will close. For output frequencies above P4-12, the drive standard deceleration rates apply and the message and digital output will clear. When this parameter is set to 0.0, the drive will use the standard deceleration rate.

### ■ P4-17: Utility Start Delay

Sets the delay time after power up until the drive will recognize a Run command present within one second of power up or when the Run command is jumpered on the terminal strip.

This is useful in preventing a peak power surge when multiple drives power up and begin accelerating simultaneously. This function works when the drives all have different P4-17 settings to spread out the power draw during acceleration.

If the Run command is removed and re-applied during the P4-17 time, the drive will cancel the utility start delay and immediately begin running.

The Utility Start Delay is applied when the drive is auto-restarting after an Undervoltage (Uv) or an Overvoltage (ov) condition.

| No.   | Parameter Name      | Setting Range     | Default |
|-------|---------------------|-------------------|---------|
| P4-17 | Utility Start Delay | 0.0 to 1000.0 min | 0.2 min |

### ■ P4-21: Low City Input Select

Selects the type of pressure switch connected to the “Low City Press” digital input (H1-0□ = 73).

| No.   | Name                  | Setting Range | Default |
|-------|-----------------------|---------------|---------|
| P4-21 | Low City Input Select | 0, 1          | 1       |

**Setting 0: Normally open**

**Setting 1: Normally closed**

### ■ P4-22: Low City On-Delay Time

Sets the amount of time a “Low City Pressure” condition must be present before the drive will stop.

| No.   | Name                         | Setting Range | Default |
|-------|------------------------------|---------------|---------|
| P4-22 | Low City Input On-Delay Time | 1 to 1000 s   | 10 s    |

## 5.11 P: Pump

### ■ P4-23: Low City Off-Delay Time

Sets the amount of time a “Low City Pressure” condition must be absent before the drive will restart.

| No.   | Name                          | Setting Range | Default |
|-------|-------------------------------|---------------|---------|
| P4-23 | Low City Input Off-Delay Time | 1 to 1000 s   | 5 s     |

### ■ P4-24: Low City Alarm Text

Selects the alarm message that will be displayed when a "Low City Pressure" condition is detected.

| No.   | Name                | Setting Range | Default |
|-------|---------------------|---------------|---------|
| P4-24 | Low City Alarm Text | 0 to 2        | 0       |

**Setting 0: Low city pressure**

**Setting 1: Low suction pressure**

**Setting 2: Low water in tank**

### ■ P4-25: Remote Drive Disable Selection

| No.   | Name                           | Setting Range | Default |
|-------|--------------------------------|---------------|---------|
| P4-25 | Remote Drive Disable Selection | 0, 1          | 1       |

**Setting 0: Normally open**

When this parameter is set to 0 and digital input H1-0□ = 95 (Remote Drive Disable) is closed for the time set in P4-26, Drive Disable On-Delay, the drive will stop according to the method set in b1-03.

The drive will not run, and will display the “R-DNE-Sx” alarm where “Sx” denotes the digital input terminal programmed for this function. For example, if H1-03 = 95, the alarm will display: “R-DNE-S3”.

To be able to run again, the Remote Drive Disable digital input has to be opened for the time set in P4-27, Drive Disable Off-Delay.

**Setting 1: Normally closed**

When this parameter is set to 0 and digital input H1-0□ = 95 (Remote Drive Disable) is opened for the time set in P4-26, Drive Disable On-Delay, the drive will stop according to the method set in b1-03.

When drive run is disabled using this feature, the Pre-Charge function is reset and will run if necessary when drive run is enabled.

### ■ P4-26: Remote Drive Disable On-Delay

Sets the amount of time a “Remote Drive Disable” condition must be present before the drive will stop.

| No.   | Name                          | Setting Range | Default |
|-------|-------------------------------|---------------|---------|
| P4-26 | Remote Drive Disable On-Delay | 0 to 1000 s   | 0 s     |

### ■ P4-27: Remote Drive Disable Off-Delay

Sets the amount of time a “Remote Drive Disable” condition must be absent before the drive will be allowed to restart.

| No.   | Name                           | Setting Range | Default |
|-------|--------------------------------|---------------|---------|
| P4-27 | Remote Drive Disable Off-Delay | 0 to 1000 s   | 0 s     |

### ■ P4-29: Lube Pump Message Text

Selects which text is displayed when Lube Pump is active. Also changes the text for the Lube Pump Digital Output selection (H2-□□ = 8B)

| No.   | Name                   | Setting Range | Default |
|-------|------------------------|---------------|---------|
| P4-29 | Lube Pump Message Text | 0, 1          | 0       |

**Setting 0: Lube Pump**

**Setting 1: Digital Out Delay**

### ■ P4-30: Lube Pump Active During Run

When enabled, the Lube Pump digital output stays activated after the timer expires and the drive starts to run normally. The output is deactivated only when the drive stops, faults, or sleeps.

| No.   | Name                        | Setting Range | Default |
|-------|-----------------------------|---------------|---------|
| P4-30 | Lube Pump Active During Run | 0, 1          | 0       |

**Setting 0: Disabled****Setting 1: Active During Run****■ P4-31: Lube Pump / Digital Output Delay Timer**

| No.   | Name                                   | Setting Range  | Default |
|-------|--|----------------|---------|
| P4-31 | Lube Pump / Digital Output Delay Timer | 0.0 to 300.0 s | 0.0 s   |

The Lube Pump / Digital Output function operates when the drive accelerates from zero speed. Instead of starting, the drive will remain baseblocked at zero speed until the lube pump / digital output timer expires.

A programmed digital output H2-0□ = 8B closes when the lube pump / digital output timer is timing (after a start or restart). This digital output can control a small lubrication pump or solenoid valve to lubricate the main pump bearings.

If an anti-jam condition is detected, the lube pump / digital output will not activate between anti-jam retries.

When P4-29 = 0 (Lube Pump), the display will show “Lube Pump Active” when Lube Pump / Digital Output (P4-31) is active. The text for multifunction digital output selection H2-□□ = 8B will read as “Lube Pump”.

When P4-29 = 1 (Digital Out Delay), the display will show “DigitalOut Delay Active” when Lube Pump / Digital Output (P4-31) is active. The text for multifunction digital output selection H2-□□ = 8B will read as “DigitalOut Delay”.

When P4-30 = 0 (Lube Pump During Run Disabled), the digital output (H2-□□ = 8B) is deactivated after Lube Pump / Digital Output timer P4-31 expires.

When P4-30 = 1 (Lube Pump Active During Run), the digital output (H2-□□ = 8B) remains active after Lube Pump / Digital Output timer P4-31 expires. It will only deactivate when the drive sleeps, stops, or faults.

**■ P4-32: Pre-Charge Level 2**

For normal PI operation during Pre-charge 2, if the PI Feedback signal rises above the P4-32 level, Pre-charge 2 is cancelled and the drive resumes normal operation.

For inverse PI operation and during Pre-charge 2, if the PI Feedback signal goes below the P4-32 level, Pre-charge 2 is cancelled and the drive resumes normal operation.

When set to zero, Pre-charge 2 still runs when P4-07 is set, but uses P4-01 to determine if normal operation should resume.

| No.   | Name               | Setting Range | Default |
|-------|--------------------|---------------|---------|
| P4-32 | Pre-Charge Level 2 | 0.0 to 6000.0 | 0.0     |

**◆ P5: Pump HAND Mode****■ P5-01: HAND Mode Reference Source**

Selects the frequency reference source for the HAND mode of operation.

| No.   | Name                       | Setting Range | Default |
|-------|----------------------------|---------------|---------|
| P5-01 | HAND Mode Reference Source | 0, 1          | 1       |

**Setting 0: Analog input**

This analog input is defaulted to input A3 (0-10 V).

**Setting 1: P5-02 (HAND reference)****■ P5-02: HAND Reference 1**

Sets the frequency reference of HAND mode. When the drive is stopped, pressing the HAND key will start the drive and the drive will accelerate to the P5-02 setting.

| No.   | Parameter Name   | Setting Range | Default |
|-------|------------------|---------------|---------|
| P5-02 | HAND Reference 1 | 0.0 to E1-04  | 40.0 Hz |

**■ P5-03: HAND/AUTO during Run Selection**

Selects if the drive will permit switching between HAND and AUTO modes while running.

## 5.11 P: Pump

Switching from AUTO to HAND is not permitted when the drive is running in Modbus multiplex mode with auxiliary drives enabled.

| No.   | Name                           | Setting Range | Default |
|-------|--------------------------------|---------------|---------|
| P5-03 | HAND/AUTO during Run Selection | 0, 1          | 0       |

**Setting 0: Disabled**

**Setting 1: Enabled**

### ■ P5-04: HAND Key Function Selection

Selects whether the HAND key on the HOA keypad is active. Disabling this function by setting P5-04 to 0 will prevent the drive from entering HAND Mode.

| No.   | Parameter Name              | Setting Range | Default |
|-------|-----------------------------|---------------|---------|
| P5-04 | HAND Key Function Selection | 0, 1          | 1       |

**Setting 0: Disabled**

**Setting 1: Enabled**

### ■ P5-05: HAND Reference 2

Sets the frequency reference used when Hand Mode 2 is active.

| No.   | Name             | Setting Range  | Default |
|-------|------------------|----------------|---------|
| P5-05 | HAND Reference 2 | 0.0 to [E1-04] | 0.0 Hz  |

### ■ P5-06: HAND Reference 1 Loss of Prime Level

Sets the level used to detect loss of prime in the pump.

| No.   | Name                                 | Setting Range | Default |
|-------|--------------------------------------|---------------|---------|
| P5-06 | HAND Reference 1 Loss of Prime Level | 0.0 to 1000.0 | 0.0 A   |

If the measured quantity set in P1-18 drops below this level for the time specified in P1-20 and the output frequency is at or above the P5-02 level, a “Loss Of Prime” condition occurs. The drive will respond to the “Loss Of Prime” condition based on P1-22 setting.

### ■ P5-07: HAND Reference 2 Loss of Prime Level

Sets the level used to detect loss of prime in the pump.

| No.   | Name                                 | Setting Range | Default |
|-------|--------------------------------------|---------------|---------|
| P5-07 | HAND Reference 2 Loss of Prime Level | 0.0 to 1000.0 | 0.0 A   |

If the measured quantity set in P1-18 drops below this level for the time specified in P1-20 and the output frequency is at or above the P5-02 level, a “Loss Of Prime” condition occurs. The drive will respond to the “Loss Of Prime” condition based on P1-22 setting.

### ■ P5-09: HAND References Set via Motor Operated Pot Selection

Selects whether parameters P5-02 and P5-05 are changed via MOP (up and down arrow keys) on the HOA keypad.

| No.   | Name   | Setting Range | Default |
|-------|--|---------------|---------|
| P5-09 | HAND References Set via Motor Operated Pot Selection | 0, 1          | 0       |

**Setting 0: Disabled**

**Setting 1: Enabled**

## ◆ P7: Anti-Jam

Anti-Jam is a method to detect and attempt to expel solids that preventing the pump impeller from turning.

The drive monitors the output current when starting from zero speed. When the current goes too high, the motor will coast to stop and switch into reverse. This cycle is repeated until the output current remains below the detection level or until the drive faults out on an “AJF – Anti-Jam Fault”.

**WARNING! Sudden Movement Hazard.** The Anti-Jam function can force the motor to briefly run in the reverse direction and may cause injury even if parameter b1-04 is set to “Reverse Disabled”. Be sure all personnel are clear of rotating machinery.

Minimum pump speed and thrust speed are disregarded during Anti-Jam operation. The pre-charge timer is held and will not increment during anti-jam or de-scale operations.

### ■ P7-01: Anti-Jam Operation Selection

Enables and disables the Anti-Jam function.

| No.   | Name                         | Setting Range | Default |
|-------|------------------------------|---------------|---------|
| P7-01 | Anti-Jam Operation Selection | 0, 1          | 0       |

Setting 0: Disabled

Setting 1: Enabled

### ■ P7-02: Anti-Jam Cycle Count

Sets the maximum number of cycle attempts before the Anti-Jam fault occurs.

| No.   | Name                 | Setting Range | Default |
|-------|----------------------|---------------|---------|
| P7-02 | Anti-Jam Cycle Count | 1 to 100      | 1       |

### ■ P7-03: Anti-Jam Detection Current Level

Sets the current level (at start) that will trigger the Anti-Jam function. Set as a percentage of motor rated current.

| No.   | Name                             | Setting Range | Default |
|-------|----------------------------------|---------------|---------|
| P7-03 | Anti-Jam Detection Current Level | 50 to 200%    | 120%    |

### ■ P7-04: Anti-Jam Detection Time at Start

Sets the amount of time the current must be above the level set in P7-03 to trigger the Anti-Jam function.

| No.   | Name                             | Setting Range | Default |
|-------|----------------------------------|---------------|---------|
| P7-04 | Anti-Jam Detection Time at Start | 0.1 to 2.0    | 0.3 s   |

### ■ P7-05: Anti-Jam During Run Current

Sets the current level (during run) that will trigger the Anti-Jam function. Set as a percentage of motor rated current.

A setting of 0% disables Anti-Jam during run.

| No.   | Name                        | Setting Range | Default |
|-------|-----------------------------|---------------|---------|
| P7-05 | Anti-Jam During Run Current | 0 to 200%     | 0%      |

### ■ P7-06: Anti-Jam During Run Time

Sets the amount of time that the current must be above the level set in P7-05 to trigger the Anti-Jam function.

| No.   | Name                     | Setting Range | Default |
|-------|--------------------------|---------------|---------|
| P7-06 | Anti-Jam During Run Time | 0.1 to 2.0 s  | 0.3 s   |

### ■ P7-07: Anti-Jam Frequency Reference

Sets the maximum speed when the Anti-Jam feature is operating.

| No.   | Name                         | Setting Range     | Default  |
|-------|------------------------------|-------------------|----------|
| P7-07 | Anti-Jam Frequency Reference | 0.00 to 400.00 Hz | 25.00 Hz |

### ■ P7-08: Anti-Jam Release Time

Sets the amount of time that the current must fall below the level set in P7-03 to resume normal operation.

| No.   | Name                  | Setting Range | Default |
|-------|-----------------------|---------------|---------|
| P7-08 | Anti-Jam Release Time | 0.5 to 10.0 s | 2.0 s   |

### ◆ P9: Network Options

#### ■ P9-01: Lead Drive Selection

Determines the selection method of the next Lead Drive.

| No.   | Name                 | Setting Range | Default |
|-------|----------------------|---------------|---------|
| P9-01 | Lead Drive Selection | 0 to 2        | 1       |

**Setting 0: Next available**

**Setting 1: Lowest runtime**

**Setting 2: Stop history**

#### ■ P9-02: Feedback Source

| No.   | Name            | Setting Range | Default |
|-------|-----------------|---------------|---------|
| P9-02 | Feedback Source | 0 to 3        | 0       |

The drive Analog PI feedback signal and status are sent to the iQpump MEMOBUS network. The status is dependent on b5-12, PI Feedback 4 to 20 mA Detection, that is run in the background per drive. If the status is good and the drive is the current Lead drive, that feedback signal is used as the Network PI Feedback and is constantly sent to all the drives in the network. When the current Lead drive does not have a good status, the Network PI Feedback is taken from another drive that has a good status.

When there is no Analog Feedback signal for PI Feedback, the drive uses the Network PI Feedback register when it is allowed and an alarm can flash if desired.

When P1-01 is set to 3, b5-12 > 0, and the PI source is 4 to 20 mA, the analog feedback detection process starts automatically for all drives that have P9-02 ≠ 3 and are ready to run on the network as soon as one of the drives receives a Run command is not running in Pre-charge mode. Drives that fail on the feedback detection will indicate that their feedback signals are invalid and will not be considered by the iQpump MEMOBUS Network as good sources. The network reads out the valid signals selected using lead-drive priority, and sends it back to all the drives as the Network PI Feedback. If the current lead drive has a valid analog feedback signal, it will be the Network PI Feedback signal. Otherwise, the Network PI Feedback signal is set to a drive with a good analog signal based on the Drive Discovery of the iQpump Memobus Network. In both cases, a status bit is also sent out indicating that the network has a good feedback source.

b5-12 = 1: Instead of alarm, NetwrkFB Lost message

b5-12 = 2: Instead of fault, NetwrkFB Lost message, drive will not accept iQpump Network run commands, and the stopping method is fixed to coast-to-stop.

Any drive with b5-12 set to 0 and P9-02 ≠ 3 will effectively have no feedback loss detection and will continuously send the Analog PI Feedback to the iQpump Network regardless if it is a healthy signal.

When b5-12 is set to 2 and P9-02 ≠ 3, PI Feedback detection will cause an alarm instead when one of the following conditions exists:

- The drive is in HAND Mode
- There is no Lead drive on the network
- The drive is not in AUTO Mode

#### Setting 0: Analog only

The drive will never read the Network PI Feedback register as the feedback source, although the drive will still transmit its own PI Feedback signal to the network. The feedback detection is based on parameter b5-12.

#### Setting 1: Ana->Net, No alarm

The drive reads the Network PI Feedback register if the analog feedback detection determines a signal loss. If the network feedback signal is also invalid, it will act according to b5-12. Setting b5-12 to 0 or using a non-4 to 20 mA PI Feedback signal disables analog feedback detection and prevents the drive from switching to the Network PI Feedback.

#### Setting 2: Ana->Net, Alarm

The drive reads the Network PI Feedback register if the analog feedback detection determines a signal loss. In addition, an alarm will be displayed indicating that the analog has been lost, and that the feedback source is now the network. If the network feedback signal is invalid as well, it will act according to the b5-12 setting. Setting b5-12 = 0 or using a non-4 to 20 mA PI Feedback signal disables analog feedback detection and prevents the drive from switching to the Network PI Feedback.

#### Setting 3: Network only

The drive will always read the Network PI Feedback register.

### ■ P9-03: Alternation Time

Sets the time for a drive to request alternation, influenced by the Alternation Mode P9-04.

The alternation feature is disabled when this parameter is set to 0.

| No.   | Name             | Setting Range | Default |
|-------|------------------|---------------|---------|
| P9-03 | Alternation Time | 0 to 1000 H   | 24 H    |

### ■ P9-04: Alternation Mode

| No.   | Name             | Setting Range | Default |
|-------|------------------|---------------|---------|
| P9-04 | Alternation Mode | 0 to 3        | 0       |

Alternation can be requested by a drive when a specified time has expired. Two basic modes allow the timer to either run from the lead drive (LIFO – Last In, First Out) or from the first drive (FIFO – First In, First Out) where the First drive is defined as the first pump that was run in the system and the Last drive is defined as the Lead Drive. When the timer expires, the drive is removed from the system, turned-off, and a new lead drive is brought online to replace it.

Alternation is enabled when P9-03, Alternation Time, is set to a non-zero value. In FIFO, the timer is run on the first drive and in LIFO it is on the lead drive. When the timer expires, the drive requests alternation based on the P9-04 setting and sends that information to the MEMOBUS network.

#### Setting 0: First in, first out auto

Removes the first drive in the running queue and starts the lead drive automatically (if needed) using the MEMOBUS Multiplex function. When there is only one drive running, then the new lead drive is forced to run since the MEMOBUS Multiplex function cannot run if there is no lead drive.

#### Setting 1: First in, first out forced

Removes the first drive in the running queue and forces a new lead drive to run.

#### Setting 2: Last in, first out

Removes the current lead drive and replaces it with a new lead drive.

#### Setting 3: First in, first out @sleep

Removes the first drive in the running queue and forces a new lead drive to run, but alternation is only requested when the drive is asleep. The new lead drive is selected using parameter P9-01.

### ■ P9-05: Lag Drive Mode

Determines the function of the lag drives.

| No.   | Name           | Setting Range | Default |
|-------|----------------|---------------|---------|
| P9-05 | Lag Drive Mode | 0, 2, 3       | 0       |

#### Setting 0: Fixed speed

Runs at the P9-06 setting after the P9-07 time expires.

#### Setting 2: Turn off

Drive stops running when it switches to a lag drive after the P9-07 time expires.

#### Setting 3: Follow lead speed

The drive will follow the speed of the current Lead drive applying P9-30 gain and P9-31 bias.

### ■ P9-06: Lag Fixed Speed

Sets the speed at which the drive will run when the drive changes from a lead to a lag after the P9-07 delay time expires and P9-05 is set to 0.

| No.   | Name            | Setting Range   | Default |
|-------|-----------------|-----------------|---------|
| P9-06 | Lag Fixed Speed | 0.0 to 400.0 Hz | 55.0 Hz |

### ■ P9-07: Lag Fixed Speed Delay

Sets the time that speed is latched when the drive changes from a lead to a lag and P9-05  $\neq$  1 before reacting based on the P9-05 setting.

## 5.11 P: Pump

| No.   | Name                  | Setting Range | Default |
|-------|-----------------------|---------------|---------|
| P9-07 | Lag Fixed Speed Delay | 0 to 1000 s   | 5 s     |

### ■ P9-08: Add Pump Mode

Selects the detection method for staging a new pump.

| No.   | Name          | Setting Range | Default |
|-------|---------------|---------------|---------|
| P9-08 | Add Pump Mode | 0 to 3        | 2       |

**Setting 0: Output frequency**

**Setting 1: Feedback**

**Setting 2: Feedback + Fout**

**Setting 3: Flow meter**

### ■ P9-09: Add Frequency Level

Sets the level above which the output frequency must rise for the time set in P9-11 for the lead drive to request a new lead drive through the iQpump Modbus network when P9-08 is set to 0.

When P9-08 is set to 2, the delta feedback (setpoint – feedback) must also exceed the level set in P9-10.

| No.   | Name                | Setting Range   | Default |
|-------|---------------------|-----------------|---------|
| P9-09 | Add Frequency Level | 0.0 to 400.0 Hz | 59.5 Hz |

### ■ P9-10: Add Delta Level

Sets the level above which the delta feedback (setpoint – feedback) for the time set in P9-11 for the lead drive to request a new lead drive through the iQpump Modbus network when P9-08 is set to 1.

When P9-08 is set to 2, the output frequency must also exceed the level set in P9-09.

| No.   | Name            | Setting Range | Default |
|-------|-----------------|---------------|---------|
| P9-10 | Add Delta Level | 0.0 to 6000.0 | 4.0 PSI |

### ■ P9-11: Add Delay Time

Sets the delay time before a new lead drive is added to the system.

| No.   | Name           | Setting Range | Default |
|-------|----------------|---------------|---------|
| P9-11 | Add Delay Time | 0 to 3600 s   | 10 s    |

### ■ P9-12: Remove Pump Mode

Selects the detection method for de-staging to the previous lead pump.

| No.   | Name             | Setting Range | Default |
|-------|------------------|---------------|---------|
| P9-12 | Remove Pump Mode | 0 to 3        | 0       |

**Setting 0: Output frequency**

**Setting 1: Feedback**

**Setting 2: Feedback + Fout**

**Setting 3: Flow meter**

### ■ P9-13: Remove Frequency Level

Sets the level below which the output frequency must fall for the time set in P9-15 for the lead drive to request to be removed from the system through the iQpump Modbus network when P9-12 is set to 0.

When P9-12 is set to 2, the delta feedback (feedback – setpoint) must also exceeded the level set in P9-14.

| No.   | Name                   | Setting Range   | Default |
|-------|------------------------|-----------------|---------|
| P9-13 | Remove Frequency Level | 0.0 to 400.0 Hz | 40.0 Hz |

### ■ P9-14: Remove Delta Level

Sets the level above which the delta feedback (setpoint – feedback) must rise for the time set in P9-15 for the lead drive to request to be removed from the system through the iQpump Modbus network when P9-12 is set to 1.



When P9-12 is set to 2, the output frequency must also fall below the level set in P9-13.

| No.   | Name               | Setting Range | Default |
|-------|--------------------|---------------|---------|
| P9-14 | Remove Delta Level | 0.0 to 6000.0 | 0.0 PSI |

### ■ P9-15: Remove Delay Time

Sets the delay time before the lead drive is removed from the system.

| No.   | Name              | Setting Range | Default |
|-------|-------------------|---------------|---------|
| P9-15 | Remove Delay Time | 0 to 3600 s   | 10 s    |

### ■ P9-16: Stabilization Time

Sets the time used to stabilize the system when a pump is staged or de-staged. Lead-lag control and pump protection is suspended during this time.

| No.   | Name               | Setting Range | Default |
|-------|--------------------|---------------|---------|
| P9-16 | Stabilization Time | 0 to 3600 s   | 3 s     |

### ■ P9-17: Setpoint Modifier

The system setpoint is incremented with the P9-17 value depending on the number of pumps running.

Pump 1: Setpoint

Pump X: Setpoint + ((X-1) (P9-17))

| No.   | Name              | Setting Range   | Default |
|-------|-------------------|-----------------|---------|
| P9-17 | Setpoint Modifier | -999.9 to 999.9 | 0.0 PSI |

### ■ P9-18: High Feedback Quick De-Stage

Sets the feedback level to trigger a quick de-stage as a percentage of parameter P1-09.

| No.   | Name                         | Setting Range | Default |
|-------|------------------------------|---------------|---------|
| P9-18 | High Feedback Quick De-Stage | 0.0 to 100.0% | 97.0%   |

The quick de-stage ignores parameters P9-12 to P9-15 and only uses an internal 2-second delay. A setting of 0.0 disables the High Feedback De-stage feature.

### ■ P9-19: Alternation Unit

Selects the units for parameter P9-03, Alternation Time.

| No.   | Name             | Setting Range | Default |
|-------|------------------|---------------|---------|
| P9-19 | Alternation Unit | 0, 1          | 0       |

**Setting 0: Hours**

**Setting 1: Minutes**

### ■ P9-20: Allow Network Run

| No.   | Name              | Setting Range | Default |
|-------|-------------------|---------------|---------|
| P9-20 | Allow Network Run | 0 to 3        | 0       |

**Setting 0: Always**

Allows the drive to respond to all network Run commands (first drive, staging, alternation).

**Setting 1: First/Alternation**

The drive is limited to being either the first drive or for alternation.

**Setting 2: First only**

The drive can only be a first drive.

## 5.11 P: Pump

### Setting 3: Alternation only

The drive is only available for alternation. When P9-04 is set to 0, FIFO Auto, and there are two drives or more running, the iQpump MEMOBUS Network does not actually alternate a drive in, but it removes the expired first drive and allows the iQpump MEMOBUS Multiplex feature to stage a new drive. Explicit alternation still occurs in FIFO Auto when there is only one drive running at time of alternation.

### ■ P9-21: Run Priority

Sets the lead drive selection priority overriding the P9-01 selection. If multiple drives have the lowest P9-21 value, then P9-01 determines which drive becomes the lead.

| No.   | Name         | Setting Range | Default |
|-------|--------------|---------------|---------|
| P9-21 | Run Priority | 1 to 16       | 8       |

### ■ P9-22: System Fault Retry

| No.   | Name               | Setting Range | Default |
|-------|--------------------|---------------|---------|
| P9-22 | System Fault Retry | 0 to 10       | 5       |

When a system fault is detected, the iQpump MEMOBUS Network sends out a system message to all other drives informing them of the fault, stops all drives that are running, and prevents any drives from running until the fault is cleared.

When Fault Restarts are enabled, system faults do not consume L5-01 attempts, but instead use P9-22. The system fault retry attempts apply to all the drives on the network and are incremented when a drive with a system fault auto-restarts. Set this parameter to the same value on all drives in the MEMOBUS network for proper operation.

The following faults are considered system faults on the MEMOBUS network and work as described below:

**Not Maintaining Setpoint:** Active on the lead drive in the network. When the lead drive has an NMS fault, it will stop all other network drives and prevent the drives from running until the fault is cleared. The HOA keypad display message “Net Pump Err” is displayed on all other network drives.

**Low Feedback / Low Water Level:** Active on any network drive. When the drive has an LFB or LWL fault, it will stop all other network drives and prevent the drives from running until the fault is cleared. The HOA keypad display message “Net Pump Err” is displayed on all other network drives.

**High Feedback / High Water Level:** Active on any network drive. When the lead drive has an HFB or HWL fault, it will stop all other network drives and prevent them from running until the fault is cleared. The HOA keypad display message “Net Pump Err” is displayed on all other network drives.

**Flow Meter: Low Flow, High Flow, and Accumulated Level:** Active on any network drive that has an Auto Run command. When the drive has a LOWFL, HIFLO, or ACCUM fault, the network stops all other drives and prevent them from running until the fault is cleared. The HOA keypad display message “Net Pump Err” is displayed on all other network drives.

Setting P9-22 to 0 disables the system restart regardless of L5-01, P4-07, and P4-08 parameter settings. When P9-22 > 0, and L5-01 = 0 or P4-07/P4-08 are set to disable the fault restart, when that drive gets a system fault, the system will not be able to restart.

When a drive with a system fault auto-restarts, the network System Fault Restart counter gets incremented and the L5-01 fault restart counter does not increase. When the system fault restart counter equals the P9-22 setting, the iQpump MEMOBUS Network disables automatic fault restart and manually resetting the fault will clear the system fault restart counter. If the iQpump MEMOBUS Network does not experience a system fault for 10 minutes, it clears the system restart fault counter.

**Note:** Losing power or communications to a drive with a system fault will clear the fault and allow other drives in the system to run.

### ■ P9-23: Maximum Number of Running Pumps

Limits the maximum number of pumps that can run on the system.

| No.   | Name                            | Setting Range | Default |
|-------|---------------------------------|---------------|---------|
| P9-23 | Maximum Number of Running Pumps | 1 to 8        | 8       |

### ■ P9-24: Lead Swap at Sleep

Sets the time that the lead drive must be asleep when another drive is available with a lower P9-21 value until the drive will request for a swap. A setting of 0 disables this function.

| No.   | Name               | Setting Range | Default |
|-------|--------------------|---------------|---------|
| P9-24 | Lead Swap at Sleep | 0 to 7200 s   | 0 s     |

### ■ P9-25: Highest Node Address

Selects the highest possible node address in the Modbus network.

To yield optimal network performance, set serial communication address H5-01 starting from 01h and then consecutively up to the last drive and then set the P9-25 parameter to highest used H5-01 address.

| No.   | Name                 | Setting Range | Default |
|-------|----------------------|---------------|---------|
| P9-25 | Highest Node Address | 2 to 8        | 8       |

### ■ P9-26: Master Time-out

Sets the minimum amount of time that the follower drives will wait for a message from the master before performing the action set in P9-27.

| No.   | Name            | Setting Range | Default |
|-------|-----------------|---------------|---------|
| P9-26 | Master Time-out | 1.0 to 10.0 s | 4.0 s   |

### ■ P9-27: Network Recovery

Sets the follower drive response action when no messages are received from the master for the time set in P9-26.

| No.   | Name             | Setting Range | Default |
|-------|------------------|---------------|---------|
| P9-27 | Network Recovery | 0 to 3        | 0       |

#### Setting 0: Automatic

Drive will attempt to assume master functionality.

#### Setting 1: Slave/resume

Drive will continue running when the master is lost, and will wait for a master to come online.

**Note:** Drive will keep running in its current operation state which could cause an undesirable condition.

#### Setting 2: Slave/stop

Drive will stop running when the master is lost, and will wait for a master to come online.

#### Setting 3: Fault MSL

Fault the drive with an MSL (Master Lost).

### ■ P9-28: NETSCAN Alarm Time

Sets the amount of time that the follower drives will wait for a message from the master before displaying a NETSCAN alarm.

| No.   | Name               | Setting Range | Default |
|-------|--------------------|---------------|---------|
| P9-28 | NETSCAN Alarm Time | 1.0 to 10.0 s | 2.0 s   |

### ■ P9-29: Net Start Delay

Sets the time that the drive will wait before selecting and starting the lead drive after the first drive on the network has been put on AUTO mode.

| No.   | Name            | Setting Range | Default |
|-------|-----------------|---------------|---------|
| P9-29 | Net Start Delay | 0.0 to 60.0 s | 2.0 s   |

### ■ P9-30: Lag Drive Speed Follower Gain

Sets the gain that will be applied to the speed of the current lead drive when Lag Drive Mode is activated.

| No.   | Name                          | Setting Range | Default |
|-------|-------------------------------|---------------|---------|
| P9-30 | Lag Drive Speed Follower Gain | 0.0 to 300.0% | 100.0%  |

### ■ P9-31: Lag Drive Speed Follower Bias

Sets the bias that will be applied to the speed of the current lead drive when Lag Drive Mode is activated.

| No.   | Name                          | Setting Range    | Default |
|-------|-------------------------------|------------------|---------|
| P9-31 | Lag Drive Speed Follower Bias | -60.0 to 60.0 Hz | 0.0 Hz  |

## 5.11 P: Pump

### ■ P9-32: Lag Follower Deceleration Time

Sets the deceleration time when the P9-33 timer is running and the drive is running as Lag Drive Speed Follower (P9-05 = 3).

| No.   | Name                           | Setting Range   | Default |
|-------|--------------------------------|-----------------|---------|
| P9-32 | Lag Follower Deceleration Time | 0.0 to 1000.0 s | 60.0 s  |

### ■ P9-33: Lag Follower Deceleration Time Active Time

Sets the window during which the P9-32 deceleration time is effective. The drive will use the standard deceleration rates when the P9-32 time expires.

A setting of 0.0 will disable the Lag Follower deceleration time switching.

| No.   | Name                                       | Setting Range  | Default |
|-------|--|----------------|---------|
| P9-33 | Lag Follower Deceleration Time Active Time | 0.0 to 360.0 s | 0.0 s   |

### ■ P9-34: Low Feedback Quick De-Stage

Sets the low feedback level that will trigger a quick de-stage. The quick de-stage ignores parameters P9-12 to P9-15 and uses an internal 2-second delay.

A setting of 0.0 disables the Low Feedback De-Stage feature.

| No.   | Name                        | Setting Range | Default |
|-------|-----------------------------|---------------|---------|
| P9-34 | Low Feedback Quick De-Stage | 0.0 to 6000.0 | 0.0 PSI |

### ■ P9-99: Network Compatibility Selection

Selects the communication compatibility for the iQpump MEMOBUS network.

| No.   | Name                            | Setting Range | Default |
|-------|---------------------------------|---------------|---------|
| P9-99 | Network Compatibility Selection | 0 to 2        | 0       |

Setting 0: A-Ver: 30034

Setting 1: B-Ver: 30035/36

Setting 2: iQ SmartNetwork

## 5.12 Q: PID Controller

### ◆ Q1: Preset Setpoint

#### ■ Q1-01: PID Controller Setpoint 1

Sets the PID setpoint for the controller. The drive will use the system feedback signal and modulate the pump speed to regulate the feedback at the Q1-01 setpoint. The units for Q1-01 are selected by b1-01 and the scaling is set in parameter P1-03. This parameter is active when b1-01 (Reference Source) is set to 0 (HOA keypad).

| No.   | Parameter Name            | Setting Range | Default |
|-------|---------------------------|---------------|---------|
| Q1-01 | PID Controller Setpoint 1 | 0.0 to 6000.0 | 0.0 PSI |

#### ■ Q1-02 to Q1-04: PID Controller Setpoint 2 to 4

Sets the PID Setpoint when the corresponding Multi Setpoint or Alternate Multi Setpoint digital inputs are closed.

| No.            | Name                           | Setting Range | Default |
|----------------|--------------------------------|---------------|---------|
| Q1-02 to Q1-04 | PID Controller Setpoint 2 to 4 | 0.0 to 6000.0 | 0.0     |

#### ■ Q1-09: Setpoint MOP

Selects whether parameters Q1-01 to Q1-04 are changed via MOP using the Up and Down arrow keys on the HOA keypad.

| No.   | Name         | Setting Range | Default |
|-------|--------------|---------------|---------|
| Q1-09 | Setpoint MOP | 0, 1          | 0       |

Setting 0: Disabled

Setting 1: Enabled

### ◆ Q3: Output Current Limit

The drive reduces the frequency reference in an attempt to limit the output current. The current limit setpoint is determined by parameter P1-11. When the actual motor current rises above the setpoint, the frequency reference is reduced by a PI controller and the minimum output frequency reference is limited to  $f_{min}$ . The HOA keypad will display a "Current Limit Foldback" alarm when the current limit function is active.

#### ■ Q3-01: Output Current Limit Select

Enables and disables the output current regulator.

| No.   | Name                        | Setting Range | Default |
|-------|-----------------------------|---------------|---------|
| Q3-01 | Output Current Limit Select | 0, 1          | 0       |

Setting 0: Disabled

Setting 1: Enabled

#### ■ Q3-02: Current Limit

Sets the value of the output current to which the drive will limit if the output current exceeds the value.

| No.   | Name          | Setting Range   | Default |
|-------|---------------|-----------------|---------|
| Q3-02 | Current Limit | 0.0 to 1000.0 A | 0.0 A   |

#### ■ Q3-10: Ripple Regulator Selection

Enables and disables the Single Phase power DC bus ripple regulator. This function will lower the output frequency if the DC bus voltage ripple exceeds the value set in Q3-11.

| No.   | Name                       | Setting Range | Default |
|-------|----------------------------|---------------|---------|
| Q3-10 | Ripple Regulator Selection | 0, 1          | 1       |

## 5.12 Q: PID Controller

---

Setting 0: Disabled

Setting 1: Enabled

### ■ Q3-11: Ripple Regulator Setpoint

Set as a percentage of the maximum amount of ripple allowed before an input phase loss fault is detected.

| No.   | Name                      | Setting Range | Default |
|-------|---------------------------|---------------|---------|
| Q3-11 | Ripple Regulator Setpoint | 0.0 to 200.0% | 95.0%   |

---

## ◆ S6: Drive Protection

### ■ S6-01: Emergency Override Speed

Sets the speed command used in emergency override mode when S6-02 = 0.

| No.   | Name                     | Setting Range     | Default |
|-------|--------------------------|-------------------|---------|
| S6-01 | Emergency Override Speed | 0.00 to 240.00 Hz | 0.00 Hz |

### ■ S6-02: Emergency Override Reference Selection

Selects the emergency override speed source.

| No.   | Name                                   | Setting Range | Default |
|-------|--|---------------|---------|
| S6-02 | Emergency Override Reference Selection | 0, 1          | 0       |

Setting 0: Use S6-01 Reference

Setting 1: Use Frequency Reference

---

## ◆ T: Motor Tuning

Auto-Tuning automatically sets and tunes parameters required for optimal motor performance.

*Refer to [T: Motor Tuning on page 368](#) for details on Auto-Tuning parameters.*

## 5.13 U: Monitor Parameters

Monitor parameters let the user view various aspects of drive performance as it is shown on the operator display.

Some monitors can be output from terminal AM by assigning the specific monitor parameter number to H4-01. [Refer to H4-01: Multi-Function Analog Terminal AM Monitor Selection on page 186](#) for details on assigning functions to the analog output.

### ◆ U1: Operation Status Monitors

Status monitors display drive status like output frequency, current etc. Refer to U1: Operation Status Monitors on page [369](#) for a complete list of U1-□□ monitors and descriptions.

### ◆ U2: Fault Trace

These monitor parameters are used to view the status of various drive aspects when a fault occurs. This information is helpful for finding out why a fault occurred. Refer to U2: Fault Trace on page [372](#) for a complete list of U2-□□ monitors and descriptions.

U2-□□ monitors are not reset when the drive is initialized. [Refer to o4-11: U2, U3 Initialization on page 221](#) for instructions to initialize the fault trace.

### ◆ U3: Fault History

These parameters display faults that have occurred during operation as well as the drive operation time when those faults occurred. Refer to U3: Fault History on page [372](#) for a complete list of U3-□□ monitors and descriptions.

U3-□□ monitors are not reset when the drive is initialized. [Refer to o4-11: U2, U3 Initialization on page 221](#) for instructions to initialize the fault trace.

### ◆ U4: Maintenance Monitors

Maintenance monitors show:

- Runtime data of the drive.
- Maintenance data and replacement information for various drive components.
- Highest peak current that has occurred and output frequency at the time the peak current occurred.

Refer to U4: Maintenance Monitors on page [374](#) for a complete list of U4-□□ monitors and descriptions.

### ◆ U5: PID Monitors

These monitors display various aspects of PID control. [Refer to PID Block Diagram on page 132](#) for a description of where each monitor is located in the PID control block.

Refer to U5: PID Monitors on page [376](#) for a complete list of U5-□□ monitors and descriptions.

### ◆ U6: Control Monitors

Control Monitors:

- Reference data for the output voltage and vector control.
- The bias value added to the frequency reference by the Up/Down 2 function. [Refer to Settings 75 and 76: Up 2/Down 2 Function on page 171.](#)

Refer to U6: Control Monitors on page [376](#).

### ◆ U9: Operation Status Monitors

Refer to U9: Operation Status Monitors on page [376](#) for a complete list of U9-□□ monitors and descriptions.

**This Page Intentionally Blank**



# Troubleshooting

---

This chapter provides descriptions of the drive faults, alarms, errors, and messages. Guidance information for troubleshooting is also included.

|            |  |            |
|------------|--|------------|
| <b>6.1</b> | <b>SECTION SAFETY.....</b>                             | <b>250</b> |
| <b>6.2</b> | <b>DRIVE FAULTS, ALARMS, ERRORS, AND MESSAGES.....</b> | <b>252</b> |
| <b>6.3</b> | <b>FAULT DETECTION.....</b>                            | <b>253</b> |
| <b>6.4</b> | <b>ALARM DETECTION.....</b>                            | <b>268</b> |
| <b>6.5</b> | <b>OPERATOR PROGRAMMING ERRORS.....</b>                | <b>280</b> |
| <b>6.6</b> | <b>COPY FUNCTION RELATED DISPLAYS.....</b>             | <b>283</b> |
| <b>6.7</b> | <b>DIGITAL OPERATOR DISPLAY MESSAGES.....</b>          | <b>285</b> |

## 6.1 Section Safety

### DANGER

#### Electrical Shock Hazard

**Do not connect or disconnect wiring while the power is on.**

Failure to comply will result in death or serious injury.

### WARNING

#### Electrical Shock Hazard

**Do not operate equipment with covers removed.**

Failure to comply could result in death or serious injury.

The diagrams in this section may illustrate drives without covers or safety shields to display details. Be sure to reinstall covers or shields before operating the drives and run the drives according to the instructions described in this manual.

**Always ground the motor-side grounding terminal.**

Improper equipment grounding could result in death or serious injury by contacting the motor case.

**Do not touch terminals before the capacitors have fully discharged.**

Failure to comply could result in death or serious injury.

Before wiring terminals, disconnect all power to the equipment. The internal capacitor remains charged even after the drive input power is turned off. The charge indicator LED will extinguish when the DC bus voltage is below 50 Vdc. To prevent electric shock, wait at least five minutes after all indicators are off and measure the DC bus voltage level to confirm safe level.

**Do not allow unqualified personnel to perform work on the drive.**

Failure to comply could result in death or serious injury.

Installation, maintenance, inspection and servicing must be performed only by authorized personnel familiar with installation, adjustment and maintenance of AC drives.

**Do not perform work on the drive while wearing loose clothing, jewelry, or without eye protection.**

Failure to comply could result in death or serious injury.

Remove all metal objects such as watches and rings, secure loose clothing and wear eye protection before beginning work on the drive.

**Do not remove covers or touch circuit boards while the power is on.**

Failure to comply could result in death or serious injury.

#### Fire Hazard

**Tighten all terminal screws to the specified tightening torque.**

Loose electrical connections could result in death or serious injury by fire due to overheating of electrical connections.

**Do not use an improper voltage source.**

Failure to comply could result in death or serious injury by fire.

Verify that the rated voltage of the drive matches the voltage of the incoming drive input power before applying power.

**Do not use improper combustible materials.**

Failure to comply could result in death or serious injury by fire.

Attach the drive to metal or other noncombustible material.

**NOTICE**

**Observe proper electrostatic discharge procedures (ESD) when handling the drive and circuit boards.**

Failure to comply may result in ESD damage to the drive circuitry.

**Never connect or disconnect the motor from the drive while the drive is outputting voltage.**

Improper equipment sequencing could result in damage to the drive.

**Do not use unshielded cable for control wiring.**

Failure to comply may cause electrical interference resulting in poor system performance. Use shielded twisted-pair wires and ground the shield to the ground terminal of the drive.

**Do not allow unqualified personnel to use the product.**

Failure to comply could result in damage to the drive or braking circuit.

Carefully review instruction manual TOBPC72060000 when connecting a braking option to the drive.

**Do not modify the drive circuitry.**

Failure to comply could result in damage to the drive and will void warranty.

Yaskawa is not responsible for modification of the product made by the user.

**Check all the wiring after installing the drive and connecting other devices to ensure that all connections are correct.**

Failure to comply could result in damage to the drive.

## 6.2 Drive Faults, Alarms, Errors, and Messages

### ◆ Types of Faults, Alarms, and Errors

Check the drive digital operator for information about possible faults if the drive or motor fails to operate.

If problems occur that are not covered in this manual, contact the nearest Yaskawa representative with the following information:

- Drive model
- Software version
- Date of purchase
- Description of the problem
- List of modified parameters.

[Table 6.1](#) contains descriptions of the various types of alarms, faults, and errors that may occur while operating the drive.

**Table 6.1 Types of Faults, Alarms, and Errors**

| Type                                     | Drive Response   | Page                |
|--|--|---------------------|
| <b>Faults</b>                            | <p>When the drive detects a fault:</p> <ul style="list-style-type: none"> <li>• The digital operator or optional HOA keypad displays text indicating the specific fault and the ALM indicator LED remains lit until the fault is reset.</li> <li>• The fault interrupts drive output and the motor coasts to a stop.</li> <li>• Some faults allow the user to select the stopping method when the fault occurs.</li> <li>• If a digital output is programmed for fault output (H2-□□ = E), it will close if a fault occurs.</li> </ul> <p>The drive will remain inoperable until the fault is cleared. <a href="#">Refer to Fault Reset Methods on page 286</a> for details.</p>   | <a href="#">253</a> |
| <b>Minor Faults and Alarms</b>           | <p>When the drive detects an alarm or a minor fault:</p> <ul style="list-style-type: none"> <li>• The digital operator/HOA keypad displays text indicating the specific alarm or minor fault, and the ALM indicator LED flashes.</li> <li>• The drive continues running the motor, although some alarms allow the user to select a stopping method when the alarm occurs.</li> <li>• A multi-function contact output set to be tripped by a minor fault (H2- □□ = 10) closes. If the output is set to be tripped by an alarm, the contact will not close.</li> <li>• The digital operator/HOA keypad displays text indicating a specific alarm and the ALM indicator LED flashes.</li> </ul> <p>Remove the cause of the problem to reset a minor fault or alarm.</p> | <a href="#">268</a> |
| <b>Operator Programming Errors</b>       | <p>An Operator Programming error occurs when parameter settings conflict or do not match hardware settings (such as with an option card).</p> <p>When the drive detects an Operator Programming error:</p> <ul style="list-style-type: none"> <li>• The digital operator/HOA keypad displays text indicating the specific error.</li> <li>• Multi-function contact outputs do not operate.</li> </ul> <p>The drive will not operate the motor until the error has been reset. Correct the settings that caused the error.</p>  | <a href="#">280</a> |
| <b>Copy Function Errors</b>              | <p>Copy Function Errors occur when using the optional HOA keypad or the USB Copy Unit to copy, read, or verify parameter settings.</p> <ul style="list-style-type: none"> <li>• The HOA keypad displays text indicating the specific error.</li> <li>• Multi-function contact outputs do not operate.</li> </ul> <p>Pressing any key on the keypad will clear the fault. Investigate the cause of the problem (such as model incompatibility) and try again.</p>   | <a href="#">283</a> |
| <b>Digital Operator Display Messages</b> | <p>The drive will display messages on the LED operator or optional HOA keypad to indicate temporary drive statuses during normal pump operation. Messages do not require any action from the user and will clear from the display automatically.</p>   | <a href="#">285</a> |

## 6.3 Fault Detection

### ◆ Fault Displays, Causes, and Possible Solutions

Table 6.2 Detailed Fault Displays, Causes, and Possible Solutions

| LED Display  | LCD Display                  | Fault Name  |
|--|------------------------------|---|
| <b>AJF</b>   | <b>AJF</b><br>Anti-Jam Fault | Anti-Jam Fault  |
| <b>Cause</b>   |                              | <b>Possible Solution</b>  |
| The drive was not able to clear debris from the impeller in fewer than the number of attempts set in P7-02. This is only effective when P7-01, Anti-jam Operation is set to 1 (enabled). |                              | <ul style="list-style-type: none"> <li>• Check for proper pump operation. Remove debris from the pump impeller.</li> <li>• Adjust the P7-03 level or the P7-02 counts.</li> <li>• Drive response to this condition is controlled by P7-01, Anti-jam Operation Selection.</li> </ul> |

| LED Display   | LCD Display | Fault Name  |
|---|-------------|---|
| <b>bUS</b>  | <b>bUS</b>  | Option Communication Error  |
| <b>Cause</b>  |             | <b>Possible Solution</b>  |
| No signal was received from the PLC                       |             | <ul style="list-style-type: none"> <li>• Check for faulty wiring.</li> </ul>  |
| Faulty communications wiring or an existing short circuit |             | <ul style="list-style-type: none"> <li>• Correct the wiring.</li> <li>• Check for disconnected cables and short circuits and repair as needed.</li> </ul>   |
| Communication data error occurred due to noise            |             | <ul style="list-style-type: none"> <li>• Check the various options available to minimize the effects of noise.</li> <li>• Counteract noise in the control circuit, main circuit, and ground wiring.</li> <li>• Ensure that other equipment such as switches or relays do not cause noise. Use surge absorbers if necessary.</li> <li>• Use only recommended cables or other shielded line. Ground the shield on the controller side or the drive input power side.</li> <li>• Separate all communication wiring from drive power lines. Install an EMC noise filter to the drive power supply input.</li> </ul> |
| The option card is damaged                                |             | Replace the option card if there are no problems with the wiring and the error continues to occur.  |
| The option card is not properly connected to the drive    |             | <ul style="list-style-type: none"> <li>• The connector pins on the option card do not line up properly with the connector pins on the drive.</li> <li>• Reinstall the option card.</li> </ul>   |

| LED Display   | LCD Display | Fault Name   |
|---|-------------|--|
| <b>CE</b>   | <b>CE</b>   | MEMOBUS/Modbus Communication Error   |
| <b>Cause</b>  |             | <b>Possible Solution</b>   |
| Faulty communications wiring or an existing short circuit |             | <ul style="list-style-type: none"> <li>• Check for faulty wiring.</li> <li>• Correct the wiring.</li> <li>• Check for disconnected cables and short circuits and repair as needed.</li> </ul>  |
| Communication data error occurred due to noise            |             | <ul style="list-style-type: none"> <li>• Check the various options available to minimize the effects of noise.</li> <li>• Counteract noise in the control circuit, main circuit, and ground wiring.</li> <li>• Use only recommended cables or other shielded line. Ground the shield on the controller side or the drive input power side.</li> <li>• Ensure that other equipment such as switches or relays do not cause noise. Use surge suppressors if required.</li> <li>• Separate all communication wiring from drive power lines. Install an EMC noise filter to the drive power supply input.</li> </ul> |

| LED Display                | LCD Display  | Fault Name  |
|----------------------------|--------------|---|
| <b>CPF02</b>               | <b>CPF02</b> | A/D Conversion Error  |
| <b>Cause</b>               |              | <b>Possible Solution</b>  |
| Control circuit is damaged |              | <ul style="list-style-type: none"> <li>• An A/D conversion error or control circuit error occurred.</li> <li>• Cycle power to the drive.</li> <li>• If the problem continues, replace the drive.</li> </ul> |

## 6.3 Fault Detection

| LED Display   | LCD Display | Fault Name  |
|---|-------------|---|
| Control circuit terminals have shorted out (+V, AC).          |             | <ul style="list-style-type: none"> <li>• Check for wiring errors along the control circuit terminals.</li> <li>• Correct the wiring.</li> </ul>             |
|   |             | Check the resistance of the speed potentiometer and related wiring.   |
| Control terminal input current has exceeded allowable levels. |             | <ul style="list-style-type: none"> <li>• Check the input current.</li> <li>• Reduce the current input to control circuit terminal (+V) to 20 mA.</li> </ul> |

| LED Display         | LCD Display | Fault Name                            |
|---------------------|-------------|---------------------------------------|
| CPF03               | CPF03       | PWM Data Error                        |
|                     |             | There is a problem with the PWM data. |
| <b>Cause</b>        |             | <b>Possible Solution</b>              |
| Hardware is damaged |             | Replace the drive.                    |

| LED Display  | LCD Display | Fault Name   |
|--|-------------|--|
| CPF06  | CPF06       | EEPROM Memory Data Error   |
|  |             | Error in the data saved to EEPROM  |
| <b>Cause</b>   |             | <b>Possible Solution</b>   |
| There is an error in EEPROM control circuit                                      |             | <ul style="list-style-type: none"> <li>• Turn off the power and check the connection between the control board and the drive.</li> <li>• If the problem continues, replace the drive.</li> </ul> |
| The power supply was switched off while parameters were being saved to the drive |             | Reinitialize the drive (A1-03 = 2220, 3330).   |

| LED Display   | LCD Display | Fault Name  |
|---|-------------|---|
| CPF07   | CPF07       | Terminal Board Communications Error                             |
|   |             | A communication error occurred at the terminal board.           |
| <b>Cause</b>  |             | <b>Possible Solution</b>  |
| There is a faulty connection between the terminal board and the control board |             | Turn off the power and reconnect the control circuit terminals. |

| LED Display   | LCD Display | Fault Name  |
|---|-------------|---|
| CPF08   | CPF08       | EEPROM Serial Communication Fault                               |
|   |             | EEPROM communications are not functioning properly.             |
| <b>Cause</b>  |             | <b>Possible Solution</b>  |
| Terminal board or control board is not connected properly.                    |             | Turn the power off and check the control terminal connections.  |
| There is a faulty connection between the terminal board and the control board |             | Turn off the power and reconnect the control circuit terminals. |

| LED Display         | LCD Display | Fault Name               |
|---------------------|-------------|--------------------------|
| CPF11               | CPF11       | RAM Fault                |
|                     |             |                          |
| <b>Cause</b>        |             | <b>Possible Solution</b> |
| Hardware is damaged |             | Replace the drive.       |

| LED Display         | LCD Display | Fault Name                           |
|---------------------|-------------|--------------------------------------|
| CPF12               | CPF12       | FLASH Memory Fault                   |
|                     |             | Problem with the ROM (FLASH memory). |
| <b>Cause</b>        |             | <b>Possible Solution</b>             |
| Hardware is damaged |             | Replace the drive.                   |

| LED Display         | LCD Display | Fault Name                 |
|---------------------|-------------|----------------------------|
| CPF13               | CPF13       | Watchdog Circuit Exception |
|                     |             | Self-diagnostics problem.  |
| <b>Cause</b>        |             | <b>Possible Solution</b>   |
| Hardware is damaged |             | Replace the drive.         |

| LED Display         | LCD Display | Fault Name  |
|---------------------|-------------|---|
| CPF 14              | CPF14       | Control Circuit Fault                                   |
|                     |             | CPU error (CPU operates incorrectly due to noise, etc.) |
| Cause               |             | Possible Solution                                       |
| Hardware is damaged |             | Replace the drive.                                      |

| LED Display         | LCD Display | Fault Name            |
|---------------------|-------------|-----------------------|
| CPF 16              | CPF16       | Clock Fault           |
|                     |             | Standard clock error. |
| Cause               |             | Possible Solution     |
| Hardware is damaged |             | Replace the drive.    |

| LED Display         | LCD Display | Fault Name  |
|---------------------|-------------|---|
| CPF 17              | CPF17       | Timing Fault  |
|                     |             | A timing error occurred during an internal process. |
| Cause               |             | Possible Solution                                   |
| Hardware is damaged |             | Replace the drive.                                  |

| LED Display         | LCD Display | Fault Name  |
|---------------------|-------------|---|
| CPF 18              | CPF18       | Control Circuit Fault   |
|                     |             | CPU error. Non-Maskable Interrupt (An unusual interrupt was triggered by noise, etc.) |
| Cause               |             | Possible Solution   |
| Hardware is damaged |             | Replace the drive.  |

| LED Display         | LCD Display | Fault Name                                  |
|---------------------|-------------|---|
| CPF 19              | CPF19       | Control Circuit Fault                       |
|                     |             | CPU error (Manual reset due to noise, etc.) |
| Cause               |             | Possible Solution                           |
| Hardware is damaged |             | Replace the drive.                          |

| LED Display          | LCD Display          | Fault Name   |
|----------------------|----------------------|--|
| CPF20<br>or<br>CPF21 | CPF20<br>or<br>CPF21 | One of the following faults occurred: RAM fault, FLASH memory error, watchdog circuit exception, clock error   |
|                      |                      | <ul style="list-style-type: none"> <li>• RAM fault.</li> <li>• FLASH memory error (ROM error).</li> <li>• Watchdog circuit exception (self-diagnostic error).</li> <li>• Clock error.</li> </ul> |
| Cause                |                      | Possible Solution  |
| Hardware is damaged  |                      | Replace the drive.   |

| LED Display                 | LCD Display | Fault Name  |
|-----------------------------|-------------|---|
| CPF22                       | CPF22       | A/D Conversion Fault  |
|                             |             | A/D conversion error.   |
| Cause                       |             | Possible Solution   |
| Control circuit is damaged. |             | <ul style="list-style-type: none"> <li>• Cycle power to the drive.</li> <li>• If the problem continues, replace the drive.</li> </ul> |

| LED Display         | LCD Display | Fault Name          |
|---------------------|-------------|---------------------|
| CPF23               | CPF23       | PWM Feedback Fault  |
|                     |             | PWM feedback error. |
| Cause               |             | Possible Solution   |
| Hardware is damaged |             | Replace the drive.  |

| LED Display | LCD Display | Fault Name  |
|-------------|-------------|---|
| CPF24       | CPF24       | Drive Unit Signal Fault   |
|             |             | The drive capacity cannot be detected correctly (drive capacity is checked when the drive is powered up). |

### 6.3 Fault Detection

| LED Display         | LCD Display | Fault Name         |
|---------------------|-------------|--------------------|
| Cause               |             | Possible Solution  |
| Hardware is damaged |             | Replace the drive. |

| LED Display                               | LCD Display | Fault Name   |
|---|-------------|--|
| CPF25                                     | CPF25       | Terminal Board Not Connected   |
| Cause                                     |             | Possible Solution  |
| Terminal board is not connected correctly |             | Reconnect the terminal board to the connector on the drive, then cycle the power to the drive. |

| LED Display          | LCD Display          | Fault Name            |
|----------------------|----------------------|-----------------------|
| CPF26<br>to<br>CPF35 | CPF26<br>to<br>CPF35 | Control Circuit Error |
| -----                | -----                |                       |
| CPF40<br>to<br>CPF43 | CPF40<br>to<br>CPF43 | CPU error             |
| Cause                |                      | Possible Solution     |
| Hardware is damaged  |                      | Replace the drive.    |

| LED Display                             | LCD Display | Fault Name  |
|---|-------------|---|
| E5                                      | E5          | SI-T3 Watchdog Timer Error  |
|   |             | The watchdog timed out.   |
| Cause                                   |             | Possible Solution   |
| Data has not been received from the PLC |             | Execute DISCONNECT or ALM_CLR, then issue a CONNECT command or SYNC_SET command and proceed to phase 3. Refer to the SI-T3 Option Technical Manual for more details on troubleshooting. |

| LED Display   | LCD Display | Fault Name   |
|---|-------------|--|
| EF0   | EF0         | Option Card External Fault   |
|   |             | An external fault condition is present.  |
| Cause   |             | Possible Solution  |
| An external fault was received from the PLC and F6-03 is set to a value other than 3. |             | <ul style="list-style-type: none"> <li>Remove the cause of the external fault.</li> <li>Remove the external fault input from the PLC.</li> </ul> |
| Problem with the PLC program  |             | Check the PLC program and correct problems.  |

| LED Display                                  | LCD Display | Fault Name   |
|--|-------------|--|
| EF1  | EF1         | Pump Fault (input terminal S1)   |
|  |             | External fault at multi-function input terminal S1.  |
| EF2  | EF2         | Pump Fault (input terminal S2)   |
|  |             | External fault at multi-function input terminal S2.  |
| EF3  | EF3         | Pump Fault (input terminal S3)   |
|  |             | External fault at multi-function input terminal S3.  |
| EF4  | EF4         | Pump Fault (input terminal S4)   |
|  |             | External fault at multi-function input terminal S4.  |
| EF5  | EF5         | Pump Fault (input terminal S5)   |
|  |             | External fault at multi-function input terminal S5.  |
| EF6  | EF6         | Pump Fault (input terminal S6)   |
|  |             | External fault at multi-function input terminal S6.  |
| EF7  | EF7         | Pump Fault (input terminal S7)   |
|  |             | External fault at multi-function input terminal S7.  |
| Cause  |             | Possible Solution  |
| An external device tripped an alarm function |             | Remove the cause of the external fault and reset the fault.  |
| Wiring is incorrect                          |             | <ul style="list-style-type: none"> <li>Properly connect the signal lines to the terminals assigned for external fault detection (H1-□□ = 20 to 2F).</li> <li>Reconnect the signal line.</li> </ul> |



| LED Display                                       | LCD Display | Fault Name  |
|---|-------------|---|
| Multi-function contact input setting is incorrect |             | <ul style="list-style-type: none"> <li>Check for unused terminals set for H1-□□ = 20 to 2F (External Pump Fault).</li> <li>Change the terminal settings.</li> </ul> |

| LED Display  | LCD Display | Fault Name  |
|--|-------------|---|
| <i>Err</i>   | Err         | EEPROM Write Error  |
|  |             | Data cannot be written to the EEPROM  |
| <b>Cause</b>   |             | <b>Possible Solution</b>  |
| Noise has corrupted data while writing to the EEPROM |             | <ul style="list-style-type: none"> <li>Press “ENTER” on the digital operator.</li> <li>Correct the parameter setting.</li> <li>Cycle power to the drive.</li> <li>If the problem continues, replace the drive.</li> </ul> |
| Hardware problem                                     |             | If the problem continues, replace the drive.  |

| LED Display                            | LCD Display | Fault Name  |
|--|-------------|---|
| <i>FAn</i>                             | FAn         | Internal Cooling Fan Failure  |
| <b>Cause</b>                           |             | <b>Possible Solution</b>  |
| Internal cooling fan has malfunctioned |             | <ul style="list-style-type: none"> <li>Cycle power to the drive.</li> <li>Check for fan operation.</li> <li>If the problem continues, replace the fan.</li> </ul> |

| LED Display   | LCD Display      | Fault Name  |
|---|------------------|---|
| <i>Fdb-L</i>  | FDBKL Wire Break | PID Feedback Loss   |
|   |                  | The analog input programmed for PID feedback has risen above 21 mA or fallen below 3 mA.  |
| <b>Cause</b>  |                  | <b>Possible Solution</b>  |
| The analog input programmed for PID feedback loss has risen above 21 mA or fallen below 3 mA. This is effective only when b5-12 Feedback Loss 4 to 20 mA Detection Selection is set to 2 (fault). |                  | <ul style="list-style-type: none"> <li>Confirm that the PID feedback source is installed and working properly.</li> <li>Drive response to this condition is controlled by b5-12, Feedback Loss 4 to 20 mA Detection Selection and b5-13, Feedback Loss Go To Frequency.</li> <li>Auto-restart of this fault is controlled by L5-42, Feedback Loss Fault Retry Selection.</li> </ul> |

| LED Display  | LCD Display | Fault Name   |
|--|-------------|--|
| <i>GF</i>  | GF          | Ground Fault   |
|  |             | <ul style="list-style-type: none"> <li>A current short to ground exceeded 50% of rated current on the output side of the drive.</li> <li>Setting L8-09 to 1 enables ground fault detection in models 2V0020 to 2V0069 and 4V0011 to 4V0038.</li> </ul> |
| <b>Cause</b>   |             | <b>Possible Solution</b>   |
| Motor insulation is damaged  |             | <ul style="list-style-type: none"> <li>Check the insulation resistance of the motor.</li> <li>Replace the motor.</li> </ul>  |
| A damaged motor cable is creating a short circuit                                  |             | <ul style="list-style-type: none"> <li>Check the motor cable.</li> <li>Remove the short circuit and reapply power to the drive</li> <li>Check the resistance between the cable and the ground terminal.</li> <li>Replace the cable.</li> </ul>         |
| Excessive leakage current at the drive output                                      |             | <ul style="list-style-type: none"> <li>Reduce the carrier frequency.</li> <li>Reduce the amount of stray capacitance.</li> </ul>   |
| The drive started to run during a current offset fault or while coasting to a stop |             | <ul style="list-style-type: none"> <li>Set b3-01 to 1 to enable Speed Search at Start.</li> <li>Perform Speed Search 1 or 2 (H1-□□ = 61 or 62) via one of the external terminals.</li> </ul>   |
| Hardware problem   |             | If the problem continues, replace the drive.   |

| LED Display  | LCD Display | Fault Name                       |
|--------------|-------------|----------------------------------|
| <i>HFB</i>   | HFB         | High Feedback                    |
|              |             | The feedback signal is too high. |
| <b>Cause</b> |             | <b>Possible Solution</b>         |

## 6.3 Fault Detection

| LED Display   | LCD Display | Fault Name   |
|---|-------------|--|
|   |             |  |
| The feedback signal has risen above the level set in P1-11, High Feedback Level, for the time set in P1-12, High Feedback Level Fault Delay Time.<br>This is effective only when P1-13, High Feedback Selection, is set to 0 (Fault and digital out). |             | <ul style="list-style-type: none"> <li>Set the High Feedback fault characteristics in P1-11 and P1-12.</li> <li>Drive response to this condition is controlled by P1-13, High Feedback Selection. Auto-restart of this fault is controlled by L5-41, High Feedback Fault Retry Selection.</li> </ul> |

| LED Display  | LCD Display | Fault Name   |
|--|-------------|--|
| H 1H20   | HWL         | High Water Level   |
|  |             | The "High Water Level" digital input is active (H1-0□ = 90).     |
| <b>Cause</b>   |             | <b>Possible Solution</b>   |
| The Low Water Level switch is activated or P1-31, High Water Digital Input Configuration, is programmed incorrectly. |             | Lower the water level and/or adjust the High Water Level switch. |

| LED Display  | LCD Display | Fault Name   |
|--|-------------|--|
| LF   | LF          | Output Phase Loss  |
|  |             | <ul style="list-style-type: none"> <li>Phase loss on the output side of the drive.</li> <li>Setting L8-07 to 1 or 2 enables Phase Loss Detection.</li> </ul>   |
| <b>Cause</b>   |             | <b>Possible Solution</b>   |
| The output cable is disconnected   |             | <ul style="list-style-type: none"> <li>Check for wiring errors and properly connect the output cable.</li> <li>Correct the wiring.</li> </ul>  |
| The motor winding is damaged   |             | <ul style="list-style-type: none"> <li>Check the resistance between motor lines.</li> <li>Replace the motor if the winding is damaged.</li> </ul>  |
| The output terminal is loose   |             | <ul style="list-style-type: none"> <li>Apply the tightening torque specified in this manual to fasten the terminals. <i>Refer to Wire Gauges and Tightening Torques on page 50</i> for details.</li> </ul> |
| The rated current of the motor being used is less than 5% of the drive rated current |             | Check the drive and motor capacities.  |
| An output transistor is damaged  |             | If the problem continues, replace the drive.   |
| A single-phase motor is being used   |             | The drive cannot operate a single phase motor.   |

| LED Display   | LCD Display | Fault Name  |
|---|-------------|---|
| LF2   | LF2         | Output current imbalance  |
|   |             | One or more of the phases in the output current is lost.  |
| <b>Cause</b>  |             | <b>Possible Solution</b>  |
| Phase loss has occurred on the output side of the drive.  |             | <ul style="list-style-type: none"> <li>Check for faulty wiring or poor connections on the output side of the drive.</li> <li>Correct the wiring.</li> </ul>   |
| Terminal wires on the output side of the drive are loose. |             | Apply the tightening torque specified in this manual to fasten the terminals. <i>Refer to Wire Size and Torque Specifications on page 57</i> for details.   |
| No signal displays from the gate driver board.            |             | Replace the drive. Contact Yaskawa for assistance.  |
| Motor impedance or motor phases are uneven.               |             | <ul style="list-style-type: none"> <li>Measure the line-to-line resistance for each motor phase. Ensure all values are the same.</li> <li>Replace the motor. Contact Yaskawa for assistance.</li> </ul> |

| LED Display  | LCD Display | Fault Name   |
|--|-------------|--|
| Lfb  | LFB         | Low Feedback   |
|  |             | The feedback signal is too low.  |
| <b>Cause</b>   |             | <b>Possible Solution</b>   |
| The feedback signal has dropped below the level set in P1-08, Low Feedback Level, for the time set in P1-09, Low Feedback Level Fault Delay Time.<br>This is effective only when P1-10, Low Feedback Selection, is set to 0 (Fault and digital out). |             | <ul style="list-style-type: none"> <li>Set the Low Feedback fault characteristics in P1-08 and P1-09.</li> <li>Drive response to this condition is controlled by P1-10, Low Feedback Selection.</li> <li>Auto-restart of this fault is controlled by L5-40, Low Feedback Fault Retry Selection.</li> </ul> |

| LED Display   | LCD Display | Fault Name   |
|---|-------------|--|
| LOP   | LOP         | Loss of Prime  |
|   |             | The pump has lost its prime.   |
| <b>Cause</b>  |             | <b>Possible Solution</b>   |
| The pump load, measured based on the P1-18 setting (output current, kilowatts, or power), has dropped below the level set in P1-19, Prime Loss Level, for the time set in P1-20, Loss of Prime Time, and the output frequency has risen above P1-21, Prime Loss Frequency. This is effective only when P1-22 Loss of Prime Selection is set to 0 (fault). |             | <ul style="list-style-type: none"> <li>• Check for a dry well, air in the system, or no water in the system. Restart the pump using the preferred priming method suggested by the pump manufacturer.</li> <li>• Set the Loss of Prime fault characteristics in P1-18, P1-19, P1-20, and P1-21.</li> <li>• Drive response to this condition is controlled by P1-21, Loss of Prime Selection.</li> <li>• Auto-restart of this fault is controlled by L5-51, Loss of Prime Fault Retry Selection and P1-23, Loss of Prime Maximum Restart Time after Fault</li> </ul> |

| LED Display   | LCD Display | Fault Name  |
|---|-------------|---|
| LOW20   | LWL         | Low Water Level   |
|   |             | The “Low Water Level” digital input is active (H1-0□ = 8F).     |
| <b>Cause</b>  |             | <b>Possible Solution</b>  |
| The Low Water Level switch is activated, defective, or P1-30, Low Water Digital Input Configuration, is programmed incorrectly. |             | Raise the water level and/or adjust the Low Water Level switch. |

| LED Display   | LCD Display            | Fault Name  |
|---|------------------------|---|
| nSL   | MSL<br>Net Master Loss | Net Master Lost   |
|   |                        | The MEMOBUS master has been lost  |
| <b>Cause</b>  |                        | <b>Possible Solution</b>  |
| Network Recovery is set to Fault MSL (P9-27 = 3) and no message has been received from the master within the time set in P9-26. |                        | <ul style="list-style-type: none"> <li>• Increase the P9-26 setting to account for network latency.</li> <li>• Verify that there is a drive on the network with parameter P1-01 set to 3 and P9-27 to 0.</li> <li>• Check network connections and verify H5-01 and P9-25 settings for all drives on the network.</li> </ul> |

| LED Display   | LCD Display | Fault Name  |
|---|-------------|---|
| notSP   | NMS         | Not Maintaining Setpoint  |
|   |             | The setpoint cannot be maintained and P1-17 is set to 0.  |
| <b>Cause</b>  |             | <b>Possible Solution</b>  |
| When the feedback deviates from the setpoint at a level greater than P1-15, for a time set in P1-16. This is effective only when P1-17 is set to 0 (fault). |             | <ul style="list-style-type: none"> <li>• Check for a blocked impeller, over cycling, or broken pipe.</li> <li>• Set the Not Maintaining Setpoint fault characteristics in P1-16 and P1-17.</li> <li>• Drive response to this condition is controlled by P1-17, Not Maintaining Setpoint Selection.</li> <li>• Auto-restart of this fault is controlled by L5-50, Setpoint Not Met Retry.</li> </ul> |

| LED Display  | LCD Display | Fault Name  |
|--|-------------|---|
| nSE  | nSE         | Node Setup Error  |
|  |             | A terminal assigned to the node setup function closed during run. |
| <b>Cause</b>   |             | <b>Possible Solution</b>  |
| The node setup terminal closed during run.<br>A Run command was issued while the node setup function was active. |             | Stop the drive when using the node setup function.                |

| LED Display  | LCD Display | Fault Name   |
|--|-------------|--|
| oC   | oC          | Overcurrent  |
|  |             | Drive sensors detected an output current greater than the specified overcurrent level.   |
| <b>Cause</b>   |             | <b>Possible Solution</b>   |
| The motor has been damaged due to overheating or the motor insulation is damaged |             | <ul style="list-style-type: none"> <li>• Check the insulation resistance.</li> <li>• Replace the motor.</li> </ul>   |
| One of the motor cables has shorted out or there is a grounding problem          |             | <ul style="list-style-type: none"> <li>• Check the motor cables.</li> <li>• Remove the short circuit and reapply power to the drive.</li> <li>• Check the resistance between the motor cables and the ground terminal.</li> <li>• Replace damaged cables.</li> </ul> |

### 6.3 Fault Detection

| LED Display  | LCD Display | Fault Name   |
|--|-------------|--|
| The load is too heavy  |             | <ul style="list-style-type: none"> <li>Measure the current flowing into the motor.</li> <li>Replace the drive with a larger capacity drive if the current value exceeds the rated current.</li> <li>Determine if there is sudden fluctuation in the current level.</li> <li>Reduce the load to avoid sudden changes in the current level or switch to a larger drive.</li> </ul>   |
| The acceleration or deceleration times are too short   |             | Calculate the torque needed during acceleration relative to the load inertia and the specified acceleration time. If it is not possible to set the proper amount of torque, make the following changes: <ul style="list-style-type: none"> <li>Increase the acceleration time (C1-01, C1-03).</li> <li>Increase the S-curve characteristics (C2-01 through C2-04).</li> <li>Increase the capacity of the drive.</li> </ul> |
| The drive is attempting to operate a specialized motor or a motor larger than the maximum size allowed |             | <ul style="list-style-type: none"> <li>Check the motor capacity.</li> <li>Ensure that the rated capacity of the drive is greater than or equal to the capacity rating found on the motor nameplate.</li> </ul>   |
| Magnetic contactor (MC) on the output side of the drive has turned on or off                           |             | Set up the operation sequence so the MC does not trip while the drive is outputting current.   |
| V/f setting is not operating as expected   |             | <ul style="list-style-type: none"> <li>Check the ratios between the voltage and frequency.</li> <li>Set parameters E1-04 through E1-10 appropriately.</li> <li>Lower the voltage if it is too high relative to the frequency.</li> </ul>   |
| Excessive torque compensation  |             | <ul style="list-style-type: none"> <li>Check the amount of torque compensation.</li> <li>Reduce the torque compensation gain (C4-01) until there is no speed loss and less current.</li> </ul>   |
| Drive fails to operate properly due to noise interference  |             | <ul style="list-style-type: none"> <li>Review the possible solutions provided for handling noise interference.</li> <li>Review the section on handling noise interference and check the control circuit lines, main circuit lines, and ground wiring.</li> </ul>   |
| Overexcitation gain is set too high  |             | <ul style="list-style-type: none"> <li>Check if the fault occurs simultaneously with overexcitation function operation.</li> <li>Consider motor flux saturation and reduce the value of n3-13 (Overexcitation Deceleration Gain).</li> </ul>   |
| Run command was applied while motor was coasting   |             | <ul style="list-style-type: none"> <li>Set b3-01 to 1 to enable Speed Search at Start.</li> <li>Program the Speed Search command input through one of the multi-function contact input terminals (H1-□□ = 61 or 62).</li> </ul>  |
| The rated output current of the drive is too small   |             | Use a larger drive.  |

| LED Display  | LCD Display  | Fault Name   |
|--|--------------|--|
| <b>oFA00</b>   | <b>oFA00</b> | Option Card Connection Error at Option Port CN5  |
|  |              | Option compatibility error   |
| <b>Cause</b>   |              | <b>Possible Solution</b>   |
| The option card installed into port CN5 is incompatible with the drive |              | Check if the drive supports the option card to be installed. Contact Yaskawa for assistance. |

| LED Display                                      | LCD Display  | Fault Name  |
|--|--------------|---|
| <b>oFA01</b>                                     | <b>oFA01</b> | Option Card Fault at Option Port CN5  |
|  |              | Option not properly connected   |
| <b>Cause</b>                                     |              | <b>Possible Solution</b>  |
| The option card connection to port CN5 is faulty |              | <ul style="list-style-type: none"> <li>Turn off the power and reconnect the option card.</li> <li>Check if the option card is properly plugged into the option port. Make sure the card is fixed properly.</li> </ul> |

| LED Display                        | LCD Display                        | Fault Name   |
|------------------------------------|------------------------------------|--|
| <b>oFA03</b><br><b>oFA04</b>       | <b>oFA03</b><br><b>oFA04</b>       | Option Card Error Occurred at Option Port CN5  |
| <b>oFA30</b><br>to<br><b>oFA43</b> | <b>oFA30</b><br>to<br><b>oFA43</b> | Communication Option Card Connection Error (CN5)   |
| <b>Cause</b>                       |                                    | <b>Possible Solution</b>   |
| Option card or hardware is damaged |                                    | <ul style="list-style-type: none"> <li>Cycle power to the drive.</li> <li>If the problem continues, replace the control board or the entire drive. Contact Yaskawa or a Yaskawa representative for instructions on replacing the control board.</li> </ul> |

| LED Display                         | LCD Display | Fault Name   |
|-------------------------------------|-------------|--|
| oH                                  | oH          | Heatsink Overheat  |
|                                     |             | The heatsink temperature exceeded the overheat pre-alarm level set to L8-02.   |
| <b>Cause</b>                        |             | <b>Possible Solution</b>   |
| Surrounding temperature is too high |             | <ul style="list-style-type: none"> <li>Check the temperature surrounding the drive. Verify temperature is within drive specifications.</li> <li>Improve the air circulation within the enclosure panel.</li> <li>Install a fan or air conditioner to cool the surrounding area.</li> <li>Remove anything near the drive that might be producing excessive heat.</li> </ul> |
| Load is too heavy                   |             | <ul style="list-style-type: none"> <li>Measure the output current.</li> <li>Decrease the load.</li> <li>Lower the carrier frequency (C6-02).</li> </ul>  |
| Internal cooling fan is stopped     |             | <ul style="list-style-type: none"> <li>Replace the cooling fan. .</li> <li>After replacing the cooling fan, set parameter o4-03 to 0 to reset the cooling fan maintenance.</li> </ul>  |

| LED Display   | LCD Display | Fault Name  |
|---|-------------|---|
| oH1   | oH1         | Overheat 1 (Heatsink Overheat)  |
|   |             | The heatsink temperature exceeded the drive overheat level.   |
| <b>Cause</b>  |             | <b>Possible Solution</b>  |
| Surrounding temperature is too high   |             | <ul style="list-style-type: none"> <li>Check the temperature surrounding the drive.</li> <li>Improve the air circulation within the enclosure panel.</li> <li>Install a fan or air conditioner to cool the surrounding area.</li> <li>Remove anything near the drive that might be producing excessive heat.</li> </ul> |
| Load is too heavy   |             | <ul style="list-style-type: none"> <li>Measure the output current.</li> <li>Lower the carrier frequency (C6-02).</li> <li>Reduce the load.</li> </ul>   |
| The internal cooling fan has reached its performance life or has malfunctioned. |             | <ul style="list-style-type: none"> <li>Check the maintenance time for the cooling fan (U4-04).</li> <li>If U4-04 exceeds 90%, replace the cooling fan.</li> <li>After replacing fan, reset the fan maintenance time (o4-03 = "0").</li> </ul>   |
| Current flowing to control circuit terminal +V exceeded the tolerance level.    |             | <ul style="list-style-type: none"> <li>Check the current level of the terminal.</li> <li>Set the current to the control circuit terminal to be 20 mA or less.</li> </ul>  |

| LED Display          | LCD Display | Fault Name   |
|----------------------|-------------|--|
| oH4                  | oH4         | Motor Overheat Fault (PTC Input)   |
|                      |             | <ul style="list-style-type: none"> <li>The motor overheat signal to analog input terminal A1 or A2 exceeded the fault detection level.</li> <li>Detection requires setting multi-function analog inputs H3-02 or H3-10 to E.</li> </ul>  |
| <b>Cause</b>         |             | <b>Possible Solution</b>   |
| Motor has overheated |             | <ul style="list-style-type: none"> <li>Check the size of the load, the accel/decel times, and the cycle times.</li> <li>Decrease the load.</li> <li>Increase the acceleration and deceleration times (C1-01 through C1-04).</li> </ul>   |
|                      |             | <ul style="list-style-type: none"> <li>Adjust the preset V/f pattern (E1-04 through E1-10) by reducing E1-08 and E1-10.</li> <li>Do not set E1-08 and E1-10 too low. This reduces load tolerance at low speeds.</li> </ul>   |
|                      |             | <ul style="list-style-type: none"> <li>Check the motor rated current.</li> <li>Enter the motor rated current to parameter E2-01 as indicated on the motor nameplate.</li> <li>Ensure the motor cooling system is operating normally.</li> <li>Repair or replace the motor cooling system.</li> </ul> |

| LED Display  | LCD Display | Fault Name  |
|--|-------------|---|
| oL1  | oL1         | Motor Overload  |
|  |             | The electronic motor overload protection tripped                        |
| <b>Cause</b>   |             | <b>Possible Solution</b>  |
| Load is too heavy  |             | Reduce the load.  |
| Cycle times are too short during acceleration and deceleration |             | Increase the acceleration and deceleration times (C1-01 through C1-04). |

## 6.3 Fault Detection

| LED Display | LCD Display   | Fault Name  |
|-------------|---|---|
|             |   | <ul style="list-style-type: none"> <li>Reduce the load.</li> <li>Increase the speed.</li> <li>If the motor is supposed to operate at low speeds, either increase the motor capacity or use a motor specifically designed to operate in the desired speed range.</li> </ul>  |
|             | A general-purpose motor is driven below the rated speed with a high load                          |   |
|             | The output voltage is too high  | <ul style="list-style-type: none"> <li>Adjust the user-set V/f pattern (E1-04 through E1-10) by reducing E1-08 and E1-10.</li> <li>Do not set E1-08 and E1-10 too low. This reduces load tolerance at low speeds.</li> </ul>  |
|             | The wrong motor rated current is set to E2-01   | <ul style="list-style-type: none"> <li>Check the motor-rated current.</li> <li>Enter the motor rated current to parameter E2-01 as indicated on the motor nameplate.</li> </ul>   |
|             | The base frequency is set incorrectly   | <ul style="list-style-type: none"> <li>Check the rated frequency indicated on the motor nameplate.</li> <li>Enter the rated frequency to E1-06 (Base Frequency).</li> </ul>   |
|             | The electrical thermal protection characteristics and motor overload characteristics do not match | <ul style="list-style-type: none"> <li>Check the motor characteristics.</li> <li>Correct the type of motor protection that has been selected (L1-01).</li> <li>Install an external thermal relay.</li> </ul>  |
|             | The electrical thermal relay is operating at the wrong level                                      | <ul style="list-style-type: none"> <li>Check the current rating listed on the motor nameplate.</li> <li>Check the value set for the motor rated current (E2-01).</li> </ul>   |
|             | Motor overheated by overexcitation operation  | <ul style="list-style-type: none"> <li>Overexcitation increases the motor loss and the motor temperature. Excessive duration of overexcitation may cause motor damage. Prevent excessive overexcitation operation or apply proper cooling to the motor.</li> <li>Reduce the excitation deceleration gain (n3-13).</li> <li>Set L3-04 (Stall Prevention during Deceleration) to a value other than 4.</li> </ul> |
|             | Parameters related to Speed Search are set incorrectly  | <ul style="list-style-type: none"> <li>Check values set to Speed Search related parameters.</li> <li>Adjust the Speed Search current and Speed Search deceleration times (b3-02 and b3-03 respectively).</li> <li>After Auto-Tuning, set b3-24 to 1 to enable Speed Estimation Speed Search.</li> </ul>   |
|             | Output current fluctuation due to power supply loss   | Check the power supply for phase loss.  |

| LED Display | LCD Display  | Fault Name   |
|-------------|--|--|
| <b>OL2</b>  | <b>OL2</b>   | Drive Overload   |
|             |  | The thermal sensor of the drive triggered overload protection.   |
|             | <b>Cause</b>   | <b>Possible Solution</b>   |
|             | Load is too heavy                                      | Reduce the load.   |
|             | Acceleration or deceleration time is too short         | Increase the settings for the acceleration and deceleration times (C1-01 through C1-04).   |
|             | The output voltage is too high                         | <ul style="list-style-type: none"> <li>Adjust the preset V/f pattern (E1-04 through E1-10) by reducing E1-08 and E1-10.</li> <li>Do not lower E1-08 and E1-10 excessively. This reduces load tolerance at low speeds.</li> </ul>   |
|             | Drive capacity is too small                            | Replace the drive with a larger model.   |
|             | Overload occurred when operating at low speeds         | <ul style="list-style-type: none"> <li>Reduce the load when operating at low speeds.</li> <li>Replace the drive with a model that is one frame size larger.</li> <li>Lower the carrier frequency (C6-02).</li> </ul>   |
|             | Excessive torque compensation                          | Reduce the torque compensation gain in parameter C4-01 until there is less current but no speed loss.  |
|             | Parameters related to Speed Search are set incorrectly | <ul style="list-style-type: none"> <li>Check the settings for all Speed Search related parameters.</li> <li>Adjust the current used during Speed Search (b3-03) and the Speed Search deceleration time (b3-02).</li> <li>After Auto-Tuning, set b3-24 to 1 to enable Speed Estimation Speed Search.</li> </ul> |
|             | Output current fluctuation due to input phase loss     | Check the power supply for phase loss.   |

| LED Display | LCD Display  | Fault Name  |
|-------------|--|---|
| <b>OL3</b>  | <b>OL3</b>   | Overtorque Detection 1  |
|             |  | The current has exceeded the value set for torque detection (L6-02) for longer than the allowable time (L6-03). |
|             | <b>Cause</b>   | <b>Possible Solution</b>  |
|             | Parameter settings are not appropriate for the load    | Check L6-02 and L6-03 settings.   |
|             | Fault on the machine side (e.g., machine is locked up) | Check the status of the load. Remove the cause of the fault.  |

| LED Display   | LCD Display | Fault Name  |
|---|-------------|---|
| oL4   | oL4         | Overtorque Detection 2  |
|   |             | The current has exceeded the value set for Overtorque Detection 2 (L6-05) for longer than the allowable time (L6-06). |
| <b>Cause</b>  |             | <b>Possible Solution</b>  |
| Parameter settings are not appropriate for the load |             | Check the settings of parameters L6-05 and L6-06.   |

| LED Display  | LCD Display | Fault Name   |
|--|-------------|--|
| oL5  | oL5         | Mechanical Weakening Detection 1                                 |
|  |             | Overtorque occurred, matching the conditions specified in L6-08. |
| <b>Cause</b>   |             | <b>Possible Solution</b>   |
| Overtorque occurred, triggering the mechanical weakening level set to L6-08. |             | Check for the cause of mechanical weakening.                     |

| LED Display  | LCD Display | Fault Name   |
|--|-------------|--|
| oPr  | oPr         | External Operator Connection Fault   |
|  |             | The external operator has been disconnected from the drive.<br><b>Note:</b> An oPr fault will occur when all of the following conditions are true: <ul style="list-style-type: none"> <li>• Output is interrupted when the keypad is disconnected (o2-06 = 1).</li> <li>• The Run command is assigned to the operator (b1-02 = 0 and HAND has been selected).</li> </ul> |
| <b>Cause</b>   |             | <b>Possible Solution</b>   |
| External operator is not properly connected to the drive |             | <ul style="list-style-type: none"> <li>• Check the connection between the keypad and the drive.</li> <li>• Replace the cable if damaged.</li> <li>• Turn off the drive input power and disconnect the keypad. Reconnect the keypad and reapply drive input power.</li> </ul>   |

| LED Display   | LCD Display | Fault Name   |
|---|-------------|--|
| oV  | oV          | Overvoltage  |
|   |             | Voltage in the DC bus has exceeded the overvoltage detection level. <ul style="list-style-type: none"> <li>• For 200 V class drives: approximately 410 V</li> <li>• For 400 V class drives: approximately 820 V (740 V when E1-01 is less than 400)</li> </ul>   |
| <b>Cause</b>  |             | <b>Possible Solution</b>   |
| Deceleration time is too short and regenerative energy is flowing from the motor into the drive                             |             | <ul style="list-style-type: none"> <li>• Increase the deceleration time (C1-02 and C1-04).</li> <li>• Install a dynamic braking resistor or a dynamic braking resistor unit.</li> <li>• Set L3-04 to 1 to enable stall prevention during deceleration. Stall Prevention is enabled as the default setting.</li> </ul>  |
| Fast acceleration time causes the motor to overshoot the speed reference  |             | <ul style="list-style-type: none"> <li>• Check if sudden drive acceleration triggers an overvoltage alarm.</li> <li>• Increase the acceleration time.</li> <li>• Use longer S-curve acceleration and deceleration times.</li> <li>• Enable the Overvoltage Suppression function (L3-11 = 1).</li> <li>• Lengthen the S-curve at acceleration end.</li> </ul>   |
| Excessive braking load  |             | The braking torque was too high, causing regenerative energy to charge the DC bus. Reduce the braking torque, use a dynamic braking option, or lengthen decel time.  |
| Surge voltage entering from the drive input power   |             | Install a DC link choke.<br><b>Note:</b> Voltage surge can result from a thyristor convertor and phase advancing capacitor using the same input power supply.  |
| Ground fault in the output circuit causes the DC bus capacitor to overcharge  |             | <ul style="list-style-type: none"> <li>• Check the motor wiring for ground faults.</li> <li>• Correct grounding shorts and reapply power.</li> </ul>   |
| Improper parameters related to Speed Search (including Speed Search after a momentary power loss and after a fault restart) |             | <ul style="list-style-type: none"> <li>• Check the settings for Speed Search-related parameters.</li> <li>• Enable Speed Search restart function (b3-19 greater than or equal to 1 to 10).</li> <li>• Adjust the current level during Speed Search and the deceleration time (b3-02 and b3-03 respectively).</li> <li>• Perform Stationary Auto-Tuning for line-to-line resistance and then set b3-14 to 1 to enable Speed Estimation Speed Search.</li> </ul> |
| Drive input power voltage is too high   |             | <ul style="list-style-type: none"> <li>• Check the voltage.</li> <li>• Lower drive input power voltage within the limits listed in the specifications.</li> </ul>  |

## 6.3 Fault Detection

| LED Display  | LCD Display | Fault Name   |
|--|-------------|--|
| The braking transistor or braking resistor are wired incorrectly |             | <ul style="list-style-type: none"> <li>Check braking transistor and braking resistor wiring for errors.</li> <li>Properly rewire the braking resistor device.</li> </ul>   |
| Drive fails to operate properly due to noise interference        |             | <ul style="list-style-type: none"> <li>Review the list of possible solutions provided for controlling noise.</li> <li>Review the section on handling noise interference and check the control circuit lines, main circuit lines, and ground wiring.</li> </ul> |
| Load inertia is set incorrectly                                  |             | <ul style="list-style-type: none"> <li>Check the load inertia settings when using KEB, overvoltage suppression, or Stall Prevention during deceleration.</li> <li>Adjust the load inertia ratio in L3-25 to better match the load.</li> </ul>                  |
| Motor hunting occurs   |             | <ul style="list-style-type: none"> <li>Adjust the parameters that control hunting.</li> <li>Set the gain for Hunting Prevention (n1-02).</li> </ul>  |

| LED Display   | LCD Display | Fault Name  |
|---|-------------|---|
| PF  | PF          | Input Phase Loss  |
|   |             | Drive input power has an open phase or has a large imbalance of voltage between phases. Detected when L8-05 is set to 1 (enabled).  |
| <b>Cause</b>  |             | <b>Possible Solution</b>  |
| There is phase loss in the drive input power                    |             | <ul style="list-style-type: none"> <li>Check for wiring errors in the main circuit drive input power.</li> <li>Correct the wiring.</li> </ul>   |
| There is loose wiring in the drive input power terminals        |             | <ul style="list-style-type: none"> <li>Ensure the terminals are tightened properly.</li> <li>Apply the tightening torque as specified in this manual. <i>Refer to Wire Gauges and Tightening Torques on page 50</i> for details.</li> </ul>                     |
| There is excessive fluctuation in the drive input power voltage |             | <ul style="list-style-type: none"> <li>Check the voltage from the drive input power.</li> <li>Review the possible solutions for stabilizing the drive input power.</li> </ul>   |
| There is poor balance between voltage phases                    |             | Stabilize drive input power or disable phase loss detection.  |
| The main circuit capacitors are worn out                        |             | <ul style="list-style-type: none"> <li>Check the maintenance time for the capacitors (U4-05).</li> <li>Replace the capacitor if U4-05 is greater than 90%. For instructions on replacing the capacitor, contact Yaskawa or a Yaskawa representative.</li> </ul> |
|   |             | Check for problems with the drive input power. If drive input power appears normal but the alarm continues to occur, replace the drive.   |

| LED Display   | LCD Display | Fault Name  |
|---|-------------|---|
| PoC   | PoC         | Pump Over Cycle   |
| <b>Cause</b>  |             | <b>Possible Solution</b>  |
| The pump has exceeded the number of cycles set in P2-10 in the time set in P2-11 and P2-12 is set to 2 (fault). |             | <ul style="list-style-type: none"> <li>Set the Pump Over Cycle fault characteristics in P2-10 and P2-11.</li> <li>Drive response to this condition is controlled by P2-12, Over Cycling Mode.</li> <li>Auto-restart of this fault is controlled by L5-52, Pump Over Cycle Fault Retry Selection.</li> <li>Set the Pump Over Cycle automatic setpoint compensation in P2-12, Over Cycling Mode, P2-13, Setpoint Compensation, and P2-14, Maximum Setpoint Compensation.</li> </ul> |

| LED Display   | LCD Display  | Fault Name  |
|---|--|---|
| rH  | rH   | Braking Resistor Overheat   |
|   |  | Braking resistor protection was triggered. Fault detection is enabled when L8-01 = 1 (disabled as a default).   |
| <b>Cause</b>  |  | <b>Possible Solution</b>  |
| Deceleration time is too short and excessive regenerative energy is flowing back into the drive |  | <ul style="list-style-type: none"> <li>Check the load, deceleration time, and speed.</li> <li>Reduce the load inertia.</li> <li>Increase the deceleration times (C1-01 to C1-04).</li> <li>Replace the dynamic braking option with a larger device that can handle the power that is discharged.</li> </ul> |
| The duty cycle is too high  |  | Check the duty cycle. Maximum of 3% duty cycle is available when L8-01 = 1.   |
| Excessive braking inertia   |  | Recalculate braking load and braking power. Reduce the braking load by adjusting braking resistor settings.   |
| The braking operation duty cycle is too high  |  | Check the braking operation duty cycle. Braking resistor protection for ERF-type braking resistors (L8-01 = 1) allows a braking duty cycle of maximum 3%.   |
| The proper braking resistor has not been installed  |  | <ul style="list-style-type: none"> <li>Check the specifications and conditions for the braking resistor device.</li> <li>Select the optimal braking resistor.</li> </ul>  |
| <b>Note:</b>  | The magnitude of the braking load trips the braking resistor overheat alarm, NOT the surface temperature. Using the braking resistor more frequently than its rating permits will trip the alarm even when the braking resistor surface is not very hot. |   |



| LED Display                       | LCD Display | Fault Name  |
|-----------------------------------|-------------|---|
| rr                                | rr          | Dynamic Braking Transistor  |
|                                   |             | The built-in dynamic braking transistor failed.   |
| <b>Cause</b>                      |             | <b>Possible Solution</b>  |
| The braking transistor is damaged |             | <ul style="list-style-type: none"> <li>• Cycle power to the drive and check for reoccurrence of the fault.</li> <li>• Replace the drive.</li> </ul> |
| The control circuit is damaged    |             |   |

| LED Display                                | LCD Display | Fault Name  |
|--|-------------|---|
| SC   | SC          | IGBT Short Circuit or Ground Fault  |
| <b>Cause</b>                               |             | <b>Possible Solution</b>  |
| IGBT fault                                 |             | <ul style="list-style-type: none"> <li>• Check motor wiring.</li> <li>• Turn off the power supply, then turn it on. If the problem continues, contact your Yaskawa representative or the nearest Yaskawa sales office.</li> </ul>                               |
| IGBT short circuit detection circuit fault |             |   |
| The drive is damaged                       |             | <ul style="list-style-type: none"> <li>• Check the drive output side short circuit for a broken output transistor B1 and U/T1, V/T2, W/T3<br/>– and U/T1, V/T2, W/T3</li> <li>• Contact your Yaskawa representative or nearest Yaskawa sales office.</li> </ul> |

| LED Display  | LCD Display | Fault Name   |
|--|-------------|--|
| SEr  | SEr         | Too Many Speed Search Restarts   |
| <b>Cause</b>   |             | <b>Possible Solution</b>   |
| Parameters related to Speed Search are set to the wrong values     |             | <ul style="list-style-type: none"> <li>• Reduce the detection compensation gain during Speed Search (b3-10).</li> <li>• Increase the current level when attempting Speed Search (b3-17).</li> <li>• Increase the detection time during Speed Search (b3-18).</li> <li>• Repeat Auto-Tuning.</li> </ul> |
| The motor is coasting in the opposite direction of the Run command |             |  |
|  |             | Set b3-14 to 1 to enable Bi-Directional Speed Search.  |

| LED Display  | LCD Display | Fault Name  |
|--|-------------|---|
| EIE  | TIE         | Time Interval Error   |
| <b>Cause</b>   |             | <b>Possible Solution</b>  |
| An error has occurred in the Real-Clock Time function of the HOA keypad. |             | Replace the HOA keypad. For instructions on replacing the HOA keypad, contact Yaskawa or your nearest sales representative. |

| LED Display   | LCD Display | Fault Name  |
|---|-------------|---|
| UL3   | UL3         | Undertorque Detection 1   |
|   |             | The current has fallen below the minimum value set for torque detection (L6-02) for longer than the allowable time (L6-03). |
| <b>Cause</b>  |             | <b>Possible Solution</b>  |
| Parameter settings are not appropriate for the load |             | Check the settings of parameters L6-02 and L6-03.   |
| There is a fault on the machine side                |             | Check the load for any problems.  |

| LED Display   | LCD Display | Fault Name  |
|---|-------------|---|
| UL4   | UL4         | Undertorque Detection 2   |
|   |             | The current has fallen below the minimum value set for torque detection (L6-05) for longer than the allowable time (L6-06). |
| <b>Cause</b>  |             | <b>Possible Solution</b>  |
| Parameter settings are not appropriate for the load |             | Check L6-05 and L6-06 settings  |
| There is a fault on the machine side                |             | Check the load for any problems.  |

| LED Display  | LCD Display             | Fault Name  |
|--------------|-------------------------|---|
| UL6          | UL6<br>Underload Det. 6 | Motor Underload   |
|              |                         | The load has fallen below the underload curve defined in L6-14. |
| <b>Cause</b> |                         | <b>Possible Solution</b>  |

## 6.3 Fault Detection

| LED Display | LCD Display | Fault Name  |
|-------------|-------------|---|
|             |             | The output current has fallen below the motor underload curve defined in L6-14 for longer than the time set to L6-03  |
|             |             | Adjust the value set to L6-14 so that output current remains above the motor underload curve during normal operation. |

| LED Display   | LCD Display | Fault Name  |
|---|-------------|---|
|   |             | DC Bus Undervoltage   |
| Uu1   | Uv1         | <p>One of the following conditions occurred while the drive was running:</p> <ul style="list-style-type: none"> <li>• Voltage in the DC bus fell below the undervoltage detection level (L2-05).</li> <li>• For 200 V class: approximately 190 V (160 V for single phase drives)</li> <li>• For 400 V class: approximately 380 V (350 V when E1-01 is less than 400) The fault is output only if L2-01 = 0 or L2-01 = 1 and the DC bus voltage is under L2-05 for longer than L2-02.</li> </ul> <p>The fault is output only if L2-01 is set to 0 or 1 and the DC bus voltage has fallen below the level set to L2-05 for longer than the time set to L2-02.</p> |
| <b>Cause</b>  |             | <b>Possible Solution</b>  |
| Input power phase loss  |             | <ul style="list-style-type: none"> <li>• The main circuit drive input power is wired incorrectly.</li> <li>• Correct the wiring.</li> </ul>   |
| One of the drive input power wiring terminals is loose              |             | <ul style="list-style-type: none"> <li>• Ensure there are no loose terminals.</li> <li>• Apply the tightening torque specified in this manual to fasten the terminals. <i>Refer to Wire Gauges and Tightening Torques on page 50</i> for details.</li> </ul>  |
| There is a problem with the voltage from the drive input power      |             | <ul style="list-style-type: none"> <li>• Check the voltage.</li> <li>• Correct the voltage to be within the range listed in drive input power specifications.</li> <li>• If there is no problem with the power supply to the main circuit, check for problems with the main circuit magnetic contactor.</li> </ul>  |
| The power has been interrupted                                      |             | Correct the drive input power.  |
| The main circuit capacitors are worn                                |             | <ul style="list-style-type: none"> <li>• Check the maintenance time for the capacitors (U4-05).</li> <li>• Replace the drive if U4-05 exceeds 90%.</li> </ul>   |
| The relay or contactor on the soft-charge bypass circuit is damaged |             | <ul style="list-style-type: none"> <li>• Cycle power to the drive and see if the fault reoccurs.</li> <li>• If the problem continues, replace the drive.</li> <li>• Check monitor U4-06 for the performance life of the soft-charge bypass.</li> <li>• Replace the drive if U4-06 exceeds 90%.</li> </ul>   |

| LED Display  | LCD Display | Fault Name  |
|--|-------------|---|
|  |             | Control Power Supply Voltage Fault  |
| Uu2  | Uv2         | Voltage is too low for the control drive input power.   |
| <b>Cause</b>   |             | <b>Possible Solution</b>  |
| L2-02 changed from its default value in drive that is 7.5 kW or smaller without installing a Momentary Power Loss Ride-Thru. |             | Correct the setting to L2-02 or install an optional Momentary Power Loss Ride-Thru unit.  |
| Control power supply wiring is damaged   |             | <ul style="list-style-type: none"> <li>• Cycle power to the drive. Check if the fault reoccurs.</li> <li>• If the problem continues, replace the control board, the entire drive, or the control power supply. For instructions on replacing the control board, contact Yaskawa or a Yaskawa representative.</li> </ul> |
| Internal circuitry is damaged  |             | <ul style="list-style-type: none"> <li>• Cycle power to the drive. Check if the fault reoccurs.</li> <li>• If the problem continues, replace the drive.</li> </ul>  |

| LED Display   | LCD Display | Fault Name  |
|---|-------------|---|
|   |             | Undervoltage 3 (Soft-Charge Bypass Circuit Fault)   |
| Uu3   | Uv3         | The soft-charge bypass circuit failed.  |
| <b>Cause</b>  |             | <b>Possible Solution</b>  |
| The relay or contactor on the soft-charge bypass circuit is damaged |             | <ul style="list-style-type: none"> <li>• Cycle power to the drive and see if the fault reoccurs.</li> <li>• If the problem continues, replace the drive.</li> <li>• Check monitor U4-06 for the performance life of the soft-charge bypass.</li> <li>• Replace the drive if U4-06 exceeds 90%.</li> </ul> |

| LED Display  | LCD Display | Fault Name               |
|--------------|-------------|--------------------------|
|              |             | Volute-Thermostat Fault  |
| ULtS         | ULTS        |                          |
| <b>Cause</b> |             | <b>Possible Solution</b> |

| LED Display   | LCD Display | Fault Name  |
|---|-------------|---|
| The digital input assigned to the volute/thermostat input (H1-0□ = 88 or 89) is active. |             | <ul style="list-style-type: none"> <li>• Check the wiring or wait for the volute or motor to cool.</li> <li>• Auto-restart of this fault is controlled by parameter L5-53, Volute-TStat Retry Selection.</li> </ul> |
| Both volute/thermostat inputs are programmed simultaneously (H1-0□ = 88 and 89).        |             | Program only one digital input to either H1-0□ = 88 or H1-0□ = 89.  |

## 6.4 Alarm Detection

**Note:** Digital operator display text is represented in the tables below using standard font for both LCD displays and LED displays. When using the standard LED operator, however, display text will appear in 7-segment LED (ex: “bU5”). When the LED fault display differs from the LCD display, the LED display text will be shown in parentheses under the LCD display text.

### ◆ Alarm Codes, Causes, and Possible Solutions

Alarms are drive protection functions that do not necessarily cause the drive to stop. After removing the cause of an alarm, the drive will return to its previous status before the alarm occurred.

When an alarm has been triggered, the ALM light on the digital operator display blinks and the alarm code display flashes. If a multi-function output is set for an alarm (H2-□□ = 10), that output terminal will be triggered.

**Note:** If a multi-function output is set to close when an alarm occurs (H2-□□ = 10), it will also close when maintenance periods are reached, triggering alarms LT-1 through LT-4 (triggered only if H2-□□ = 2F).

**Table 6.3 Alarm Codes, Causes, and Possible Solutions**

| LED Display   | LCD Display                              | Minor Fault Name  |
|---|--|---|
| <b>AEr</b>  | <b>AEr</b>                               | Station Address Setting Error (CC-Link, CANopen, MECHATROLINK)  |
|   |  | Option card node address is outside the acceptable setting range.   |
| <b>Cause</b>  |  | <b>Possible Solution</b>  |
| Station number is set outside the possible setting range.   |  | <ul style="list-style-type: none"> <li>Set parameter F6-10 to the proper value if a CC-Link option card is used</li> <li>Set parameter F6-20 to the proper value if a MECHATROLINK option card is used.</li> <li>Set parameter F6-35 to the proper value if a CANopen option card is used.</li> </ul> |
| LED Display   | LCD Display                              | Minor Fault Name  |
| <b>AFbL</b>   | <b>AnalogFB Lost<br/>Switched to Net</b> | Analog Feedback Lost  |
|   |  | Analog feedback has not been detected and the network PID feedback signal is now used.  |
| <b>Cause</b>  |  | <b>Possible Solution</b>  |
| Defective or broken analog input source.  |  | Confirm that the PID feedback source is installed and working properly. If there is no feedback source, set P9-02 to 3 so the drive will read the network PID feedback from another drive.  |
| H3-0□ is not set to B (PID Feedback)  |  | Set H3-0□ to B if the analog input source is to be used for PID feedback.<br>Set P9-02 to 3 if the drive does not have an analog PID feedback source.   |
| LED Display   | LCD Display                              | Minor Fault Name  |
| <b>AJA</b>  | <b>Anti-Jam Active</b>                   | Anti-Jam Alarm  |
|   |  |   |
| <b>Cause</b>  |  | <b>Possible Solution</b>  |
| The drive is attempting to clear debris from the impeller. This is only effective when P7-01, Anti-jam Operation is set to 1 (enabled). |  | <ul style="list-style-type: none"> <li>Alarm will clear when function is complete.</li> <li>Drive response to this condition is controlled by P7-01, Anti-jam Operation Selection.</li> </ul>   |
| LED Display   | LCD Display                              | Minor Fault Name  |
| <b>bAt</b>  | <b>bAT</b>                               | Digital Operator Battery Voltage Low  |
|   |  |   |
| <b>Cause</b>  |  | <b>Possible Solution</b>  |
| The digital operator battery is low   |  | Replace the digital operator battery.   |
| LED Display   | LCD Display                              | Minor Fault Name  |
| <b>bb</b>   | <b>bb</b>                                | Baseblock   |
|   |  | Drive output interrupted as indicated by an external baseblock signal.  |
| <b>Cause</b>  |  | <b>Possible Solution</b>  |
| External baseblock signal was entered via one of the multi-function input terminals (S1 to S7).   |  | Check external sequence and baseblock signal input timing.  |
| LED Display   | LCD Display                              | Minor Fault Name  |
| <b>bUS</b>  | <b>bUS</b>                               | Option Communication Error  |
|   |  | <ul style="list-style-type: none"> <li>The connection was lost after initial communication was established.</li> <li>Assign a Run command frequency reference to the option.</li> </ul>   |
| <b>Cause</b>  |  | <b>Possible Solution</b>  |

| LED Display  | LCD Display | Minor Fault Name   |
|--|-------------|--|
| Connection is broken or master controller stopped communicating. |             | <ul style="list-style-type: none"> <li>Check for faulty wiring.</li> <li>Correct the wiring.</li> <li>Check for disconnected cables and short circuits. Repair as needed.</li> </ul>   |
| Option is damaged.   |             | If there are no problems with the wiring and the fault continues to occur, replace the option.   |
| The option is not properly connected to the drive.               |             | <ul style="list-style-type: none"> <li>The connector pins on the option are not properly lined up with the connector pins on the drive.</li> <li>Reinstall the option.</li> </ul>  |
| A data error occurred due to noise.                              |             | <ul style="list-style-type: none"> <li>Check options available to minimize the effects of noise.</li> <li>Take steps to counteract noise in the control circuit wiring, main circuit lines and ground wiring.</li> <li>Try to reduce noise on the controller side.</li> <li>Use surge absorbers on magnetic contactors or other equipment causing the disturbance.</li> <li>Use recommended cables or some other type of shielded line. Ground the shield to the controller side or on the input power side.</li> <li>Separate the wiring for communication devices from the drive input power lines. Install an EMC noise filter to the drive input power.</li> </ul> |

| LED Display  | LCD Display | Minor Fault Name   |
|--|-------------|--|
| <b>CALL</b>  | <b>CALL</b> | Serial Communication Transmission Error  |
|  |             | Communication has not yet been established.  |
| <b>Cause</b>   |             | <b>Possible Solution</b>   |
| Communications wiring is faulty, there is a short circuit, or something is not connected properly. |             | <ul style="list-style-type: none"> <li>Check for wiring errors.</li> <li>Correct the wiring.</li> <li>Check for disconnected cables and short circuits. Repair as needed.</li> </ul> |
| Programming error on the master side.  |             | Check communications at start-up and correct programming errors.   |
| Communications circuitry is damaged.   |             | <ul style="list-style-type: none"> <li>Perform a self-diagnostics check.</li> <li>If the problem continues, replace the drive.</li> </ul>  |
| Termination resistor setting is incorrect.   |             | Install a termination resistor at both ends of a communication line. Set the internal termination resistor switch correctly on slave drives. Place DIP switch S2 to the ON position. |

| LED Display  | LCD Display | Minor Fault Name  |
|--|-------------|---|
| <b>CE</b>  | <b>CE</b>   | MEMOBUS/Modbus Communication Error  |
|  |             | Control data was not received correctly for two seconds.  |
| <b>Cause</b>   |             | <b>Possible Solution</b>  |
| A data error occurred due to noise.  |             | <ul style="list-style-type: none"> <li>Check options available to minimize the effects of noise.</li> <li>Take steps to counteract noise in the control circuit wiring, main circuit lines, and ground wiring.</li> <li>Reduce noise on the controller side.</li> <li>Use surge absorbers for the magnetic contactors or other components that may be causing the disturbance.</li> <li>Use only recommended shielded line. Ground the shield on the controller side or on the drive input power side.</li> <li>Separate all wiring for communication devices from drive input power lines. Install an EMC noise filter to the drive input power supply.</li> </ul> |
| Communication protocol is incompatible.  |             | <ul style="list-style-type: none"> <li>Check the H5 parameter settings and the protocol setting in the controller.</li> <li>Ensure settings are compatible.</li> </ul>  |
| The CE detection time (H5-09) is set shorter than the time required for a communication cycle to take place. |             | <ul style="list-style-type: none"> <li>Check the PLC.</li> <li>Change the software settings in the PLC.</li> <li>Set a longer CE detection time using parameter H5-09.</li> </ul>   |
| Incompatible PLC software settings or there is a hardware problem.   |             | <ul style="list-style-type: none"> <li>Check the PLC.</li> <li>Remove the cause of the error on the controller side.</li> </ul>   |
| Communications cable is disconnected or damaged.   |             | <ul style="list-style-type: none"> <li>Check the connector to make sure the cable has a signal.</li> <li>Replace the communications cable.</li> </ul>   |

| LED Display   | LCD Display          | Minor Fault Name         |
|---------------|----------------------|--------------------------|
| no indication | <b>Clock Not Set</b> | Clock Not Set            |
| <b>Cause</b>  |                      | <b>Possible Solution</b> |

## 6.4 Alarm Detection

| LED Display   | LCD Display | Minor Fault Name   |
|---|-------------|--|
|   |             | When the drive is powered up for the first time, the time and date must be set. The HOA keypad will display the time and date setup screen for 30 seconds. If a button is not pressed during this time, the display will clear and a "Clock Not Set" alarm will flash. |
|   |             | Pressing the F2 (Data) key will display the setting screen again.  |
| LED Display   | LCD Display | Minor Fault Name   |
| <b>CrSt</b>   | <b>CrST</b> | Cannot Reset   |
| Cause   |             | Possible Solution  |
| Fault reset was being executed when a run command was entered.  |             | <ul style="list-style-type: none"> <li>Ensure that a run command cannot be entered from the external terminals or option card during fault reset.</li> <li>Turn off the run command.</li> </ul>  |
| LED Display   | LCD Display | Minor Fault Name   |
| <b>CyC</b>  | <b>CyC</b>  | MECHATROLINK Comm. Cycle Setting Error   |
|   |             | Comm. Cycle Setting Error was detected.  |
| Cause   |             | Possible Solution  |
| The controller is using a comm. cycle beyond the allowable setting range for the MECHATROLINK option unit.                                  |             | Set the comm. cycle for the upper controller within the allowable setting range for the MECHATROLINK option unit.  |
| LED Display   | LCD Display | Minor Fault Name   |
| <b>dnE</b>  | <b>dnE</b>  | Drive Disabled   |
| Cause   |             | Possible Solution  |
| "Drive Enable" is set to a multi-function contact input (H1-□□ = 6A) and the contact is open.   |             | Check the operation sequence.  |
| LED Display   | LCD Display | Minor Fault Name   |
| <b>E5</b>   | <b>E5</b>   | MECHATROLINK Watchdog Timer Error  |
| Cause   |             | Possible Solution  |
| The watchdog timer expired while waiting for data from the controller.  |             | Issue a DISCONNECT or ALM_CLR command, followed by a CONNECT or SYNC_SET command and move to phase 3.  |
| LED Display   | LCD Display | Minor Fault Name   |
| <b>EF</b>   | <b>EF</b>   | Forward/Reverse Run Command Input Error  |
|   |             | Both forward run and reverse run closed simultaneously for longer than 0.5 s.  |
| Cause   |             | Possible Solution  |
| Sequence error  |             | Check the forward and reverse command sequence and correct the problem.<br><b>Note:</b> When minor fault EF detected, motor ramps to stop.   |
| LED Display   | LCD Display | Minor Fault Name   |
| <b>EF0</b>  | <b>EF0</b>  | Option Card External Fault   |
|   |             | An external fault condition is present.  |
| Cause   |             | Possible Solution  |
| An external fault was received from the PLC with F6-03 set to 3, which allows the drive to continue running after an external fault occurs. |             | <ul style="list-style-type: none"> <li>Remove the cause of the external fault.</li> <li>Remove the external fault input from the PLC.</li> </ul>   |
| There is a problem with the PLC program.  |             | Check the PLC program and correct problems.  |
| LED Display   | LCD Display | Minor Fault Name   |
| <b>EF1</b>  | <b>EF1</b>  | Pump Fault (Input Terminal S1)   |
|   |             | External fault at multi-function input terminal S1.  |
| <b>EF2</b>  | <b>EF2</b>  | Pump fault (input terminal S2)   |
|   |             | External fault at multi-function input terminal S2.  |

| LED Display  | LCD Display | Minor Fault Name  |
|--|-------------|---|
| EF3  | EF3         | Pump fault (input terminal S3)  |
|  |             | External fault at multi-function input terminal S3.   |
| EF4  | EF4         | Pump fault (input terminal S4)  |
|  |             | External fault at multi-function input terminal S4.   |
| EF5  | EF5         | Pump fault (input terminal S5)  |
|  |             | External fault at multi-function input terminal S5.   |
| EF6  | EF6         | Pump fault (input terminal S6)  |
|  |             | External fault at multi-function input terminal S6.   |
| EF7  | EF7         | Pump fault (input terminal S7)  |
|  |             | External fault at multi-function input terminal S7.   |
| <b>Cause</b>                                       |             | <b>Possible Solutions</b>   |
| An external device has tripped an alarm function.  |             | Remove the cause of the external fault and reset the multi-function input value.  |
| Wiring is incorrect.                               |             | <ul style="list-style-type: none"> <li>Ensure the signal lines have been connected properly to the terminals assigned for external fault detection (H1-□□ = 20 to 2F).</li> <li>Reconnect the signal line.</li> </ul> |
| Multi-function contact inputs are set incorrectly. |             | <ul style="list-style-type: none"> <li>Check if the unused terminals have been set for H1-□□ = 20 to 2F (External Fault).</li> <li>Change the terminal settings.</li> </ul>   |

| LED Display   | LCD Display | Minor Fault Name  |
|---|-------------|---|
| EoF   | EoF         | Emergency Override Forward Run                                  |
| <b>Cause</b>  |             | <b>Possible Solution</b>  |
| The multi-function digital input for EmergOverrideFWD (H1-□□ = AF) has been closed. |             | Open H1-□□ = AF if the emergency condition is no longer present |

| LED Display   | LCD Display | Minor Fault Name  |
|---|-------------|---|
| Eor   | Eor         | Emergency Override Reverse Run                                  |
| <b>Cause</b>  |             | <b>Possible Solution</b>  |
| The multi-function digital input for EmergOverrideREV (H1-□□ = B0) has been closed. |             | Open H1-□□ = B0 if the emergency condition is no longer present |

| LED Display                             | LCD Display | Minor Fault Name  |
|---|-------------|---|
| E5                                      | E5          | SI-T3 Watchdog Timer Error  |
|   |             | The watchdog timed out.   |
| <b>Cause</b>                            |             | <b>Possible Solution</b>  |
| Data has not been received from the PLC |             | Execute DISCONNECT or ALM_CLR, then issue a CONNECT command or SYNC_SET command and proceed to phase 3. Refer to the SI-T3 Option Technical Manual for more details on troubleshooting. |

| LED Display                            | LCD Display | Minor Fault Name  |
|--|-------------|---|
| FAn                                    | FAn         | Internal Cooling Fan Error  |
| <b>Cause</b>                           |             | <b>Possible Solution</b>  |
| Internal cooling fan has malfunctioned |             | <ul style="list-style-type: none"> <li>Cycle power to the drive.</li> <li>Check for fan operation.</li> <li>If the problem continues, replace the fan.</li> </ul> |

| LED Display                        | LCD Display | Minor Fault Name   |
|------------------------------------|-------------|--|
| Hbb                                | Hbb         | Safe Disable Signal Input  |
|                                    |             | The Safe Disable Input channel is open.  |
| <b>Cause</b>                       |             | <b>Possible Solutions</b>  |
| There is no signal at terminal H1. |             | Check if external safety circuit tripped and disabled the drive. If the Safe Disable function is not utilized, check if the terminals HC, H1, and H2 are linked. |

## 6.4 Alarm Detection

| LED Display  | LCD Display                                    | Minor Fault Name   |
|--|--|--|
|  |  | Internally, the Safe Disable channel is broken. Replace the drive.   |
| LED Display  | LCD Display                                    | Minor Fault Name   |
| <b>HbbF</b>  | <b>HbbF</b>                                    | Safe Disable Signal Input<br>The safe disable input hardware is defective.   |
| Cause  |  | Possible Solutions   |
| One of the Safe Disable channels is faulty.  |  | Replace the drive.   |
| LED Display  | LCD Display                                    | Minor Fault Name   |
| <b>FLGL</b>  | <b>Feedback Loss<br/>Go To Freq.<br/>b5-13</b> | PID Feedback Loss<br>The drive will run at the speed set in b5-13, Feedback Loss Goto Frequency.   |
| Cause  |  | Possible Solutions   |
| PID feedback source is incorrectly installed or is not working. Effective only when b5-12 is set to 3 (Run at b5-13).  |  | <ul style="list-style-type: none"> <li>Confirm that the PID feedback source is installed and working properly.</li> <li>Drive response to this condition is controlled by b5-12, Feedback Loss 4 to 20 mA Detection Selection, and b5-13, Feedback Loss Go To Frequency.</li> </ul>  |
| LED Display  | LCD Display                                    | Minor Fault Name   |
| <b>Fdb-L</b>   | <b>Feedback Loss<br/>Wire Break</b>            | PID Feedback Loss<br>The analog input programmed for PID feedback has gone above 21 mA or fallen below 3 mA.   |
| Cause  |  | Possible Solutions   |
| PID feedback source is incorrectly installed or is not working. This is effective only when b5-12 Feedback Loss 4 to 20 mA Detection Selection is set to 1 (alarm).  |  | <ul style="list-style-type: none"> <li>Confirm that the PID feedback source is installed and working properly.</li> <li>Drive response to this condition is controlled by b5-12, Feedback Loss 4 to 20 mA Detection Selection, and b5-13, Feedback Loss Go To Frequency.</li> <li>Auto-restart of this fault is controlled by L5-42, Feedback Loss Fault Retry Selection.</li> </ul> |
| LED Display  | LCD Display                                    | Minor Fault Name   |
| <b>PFrEF</b>   | <b>Freq. Ref Pump<br/>Min (P1-06)</b>          | Minimum Pump Frequency Reference<br>Drive frequency reference is set lower than P1-06, Minimum Pump Frequency.   |
| Cause  |  | Possible Solutions   |
| The frequency reference is set lower than P1-06. The frequency reference is internally set to the P1-06 value during this time. This will only be active when the following conditions are true: <ul style="list-style-type: none"> <li>Drive is NOT in PID Mode</li> <li>Minimum Pump Frequency is enabled (P1-06 &gt; 0.00)</li> </ul> |  | Increase the frequency reference to a value greater than P1-06.  |
| LED Display  | LCD Display                                    | Minor Fault Name   |
| <b>PEHrE</b>   | <b>Freq. Ref<br/>Thrust (P4-12)</b>            | Thrust Frequency Reference<br>The fixed frequency reference is set to a value lower than the P4-12, Thrust Frequency, setting.   |
| Cause  |  | Possible Solutions   |
| The frequency reference is set lower than P4-12. The frequency reference is internally set to the P4-12 value during this time. This will only be active when the following conditions are true: <ul style="list-style-type: none"> <li>Drive is NOT in PID Mode</li> <li>Thrust bearing is enabled (P4-12 &gt; 0.00)</li> </ul>         |  | Increase the frequency reference to a value greater than P4-12.  |
| LED Display  | LCD Display                                    | Minor Fault Name   |
| <b>HCA</b>   | <b>HCA</b>                                     | Current Alarm<br>Drive current exceeded overcurrent warning level (150% of the rated current).   |
| Cause  |  | Possible Solutions   |
| Load is too heavy.   |  | Reduce the load for applications with repetitive operations (i.e., stops and starts), or replace the drive.  |



| LED Display   | LCD Display | Minor Fault Name  |
|---|-------------|---|
| Acceleration and deceleration times are too short.  |             | <ul style="list-style-type: none"> <li>Calculate the torque required during acceleration and for the inertia moment.</li> <li>If the torque level is not right for the load, take the following steps: <ul style="list-style-type: none"> <li>Increase the acceleration and deceleration times (C1-01 through C1-04).</li> <li>Increase the capacity of the drive.</li> </ul> </li> </ul> |
| A special-purpose motor is being used, or the drive is attempting to run a motor greater than the maximum allowable capacity. |             | <ul style="list-style-type: none"> <li>Check the motor capacity.</li> <li>Use a motor appropriate for the drive. Ensure the motor is within the allowable capacity range.</li> </ul>  |
| The current level increased due to Speed Search after a momentary power loss or while attempting to perform a fault restart.  |             | The alarm will only appear briefly. There is no need to take action to prevent the alarm from occurring in such instances.  |

| LED Display  | LCD Display                     | Minor Fault Name   |
|--|---------------------------------|--|
| <b>HIFb</b>  | High Feedback<br>High FB Sensed | High Feedback Level Alarm<br>The feedback signal is too high.  |
| <b>Cause</b>   |                                 | <b>Possible Solutions</b>  |
| The feedback level has risen above the level set in P1-11, High Feedback Level. This is only effective when P1-13, High Feedback Selection, is set to 1 (Alarm and digital out). |                                 | <ul style="list-style-type: none"> <li>Decrease the feedback signal.</li> <li>Set the High Feedback alarm characteristics in P1-11 and P-12.</li> <li>Drive response to this condition is controlled by P1-13, High Feedback Selection.</li> </ul> |

| LED Display   | LCD Display | Minor Fault Name   |
|---|-------------|--|
| <b>LOP</b>  | LOP         | Loss of Prime<br>The pump has lost its prime and P1-22 is set to 1.  |
| <b>Cause</b>  |             | <b>Possible Solution</b>   |
| The measured quantity of water has dropped below the level set in P1-19, Prime Loss Level, for the time set in P1-20, Loss of Prime Time, and the output frequency has risen above P1-21, Prime Loss Frequency. This could be due to a dry well, air in the system, or no water in the system. This is effective only when P1-22 Loss of Prime Selection is set to 1 (alarm). |             | <ul style="list-style-type: none"> <li>If there is resistance in the pump, allow the system to pump water again.</li> <li>Set the Loss of Prime alarm characteristics in P1-18, P1-19, P1-20, and P1-21.</li> <li>Drive response to this condition is controlled by P1-21, Loss of Prime Selection.</li> </ul> |

| LED Display   | LCD Display       | Minor Fault Name   |
|---|-------------------|--|
| <b>LCP</b>  | Low City Pressure | Low City Pressure  |
| <b>Cause</b>  |                   | <b>Possible Solution</b>   |
| Insufficient pressure is present on the inlet to the pump. Shown when P4-24 = 0 and when the digital input has been active (closed for P4-21 = 0, or open for P4-21 = 1) for the time set in P4-22. |                   | <ul style="list-style-type: none"> <li>Check pressure switch contact for correct operation.</li> <li>Check control wiring to drive terminal strip from pressure switch contact.</li> <li>Check to make sure that suction pressure is present by means of a separate measuring device.</li> </ul> |

| LED Display  | LCD Display                   | Minor Fault Name  |
|--|-------------------------------|---|
| <b>LOFb</b>  | Low Feedback<br>Low FB Sensed | Low Feedback Level Alarm<br>The feedback signal is too low.   |
| <b>Cause</b>   |                               | <b>Possible Solutions</b>   |
| The feedback level has dropped below the level set in P1-08, Low Feedback Level. This is only effective when P1-10, Low Feedback Selection, is set to 1 (Alarm and digital out). |                               | <ul style="list-style-type: none"> <li>Increase the feedback signal.</li> <li>Set the Low Feedback alarm characteristics in P1-08 and P1-09.</li> <li>Drive response to this condition is controlled by P1-10, Low Feedback Selection.</li> </ul> |

| LED Display  | LCD Display          | Minor Fault Name         |
|--------------|----------------------|--------------------------|
| <b>LSP</b>   | Low Suction Pressure | Low Suction Pressure     |
| <b>Cause</b> |                      | <b>Possible Solution</b> |

## 6.4 Alarm Detection

| LED Display  | LCD Display                      | Minor Fault Name   |
|--|----------------------------------|--|
|  |                                  | Shown when P4-24 = 1 and when the digital input has been active (closed for P4-21 = 0, or open for P4-21 = 1) for the time set in P4-22.<br>The drive, if running, coasts-to-stop and does not run until the digital input has been inactive for the time set in P4-22.  |
|  |                                  |  |
| LED Display  | LCD Display                      | Minor Fault Name   |
| LWL  | Low Water in Tank                | Low Water in Tank  |
| Cause  |                                  | Possible Solution  |
| The water level in the tank is too low. Shown when P4-24 = 2 and when the digital input has been active (closed for P4-21 = 0, or open for P4-21 = 1) for the time set in P4-22. |                                  | <ul style="list-style-type: none"> <li>• Check pressure switch contact for correct operation.</li> <li>• Check control wiring to drive terminal strip from pressure switch contact.</li> <li>• Check to make sure that suction pressure is present by means of a separate measuring device.</li> <li>• Raise the water level.</li> </ul> |
| LED Display  | LCD Display                      | Minor Fault Name   |
| LE-1   | LT-1                             | Cooling Fan Maintenance Time   |
|  |                                  | The cooling fan has reached its expected maintenance period and may need to be replaced.<br><b>Note:</b> An alarm output (H2-□□ = 10) will only be triggered if both (H2-□□ = 2F and H2-□□ = 10) are set.  |
| Cause  |                                  | Possible Solution  |
| The cooling fan has reached 90% of its expected performance life.  |                                  | Replace the cooling fan and set o4-03 to 0 to reset the Maintenance Monitor.   |
| LED Display  | LCD Display                      | Minor Fault Name   |
| LE-2   | LT-2                             | Capacitor Maintenance Time   |
|  |                                  | The main circuit and control circuit capacitors are nearing the end of their expected performance life.<br><b>Note:</b> An alarm output (H2-□□ = 10) will only be triggered if H2-□□ = 2F.   |
| Cause  |                                  | Possible Solution  |
| The main circuit and control circuit capacitors have reached 90% of their expected performance lives.  |                                  | Replace the drive.   |
| LED Display  | LCD Display                      | Minor Fault Name   |
| LE-3   | LT-3                             | Soft Charge Bypass Relay Maintenance Time  |
|  |                                  | The DC bus soft charge relay is nearing the end of its expected performance life.<br><b>Note:</b> An alarm output (H2-□□ = 10) will only be triggered if H2-□□ = 2F.   |
| Cause  |                                  | Possible Solution  |
| The DC bus soft charge relay has reached 90% of expected performance life.   |                                  | Replace the drive.   |
| LED Display  | LCD Display                      | Minor Fault Name   |
| LE-4   | LT-4                             | IGBT Maintenance Time (50%)  |
|  |                                  | IGBTs have reached 50% of their expected performance life.<br><b>Note:</b> An alarm output (H2-□□ = 10) will only be triggered if H2-□□ = 2F.  |
| Cause  |                                  | Possible Solution  |
| IGBTs have reached 50% of their expected performance life.   |                                  | Check the load, carrier frequency, and output frequency.   |
| LED Display  | LCD Display                      | Minor Fault Name   |
| NETSC  | NETSCAN<br>Waiting for<br>Master | NETSCAN  |
|  |                                  | Drive is waiting for a message from the master.  |
| Cause  |                                  | Possible Solution  |
| No message was received from the master within the time set in P9-28.  |                                  | <ul style="list-style-type: none"> <li>• Increase the P9-26 setting to account for network latency.</li> <li>• Verify that there is a drive on the network with parameter P1-01 set to 3 and P9-27 to 0.</li> <li>• Check network connections and verify H5-01 and P9-25 settings for all drives on the network.</li> </ul>              |

| LED Display   | LCD Display | Minor Fault Name  |
|---|-------------|---|
| not SP  | NMS         | Not Maintaining Setpoint  |
|   |             | The setpoint cannot be maintained and P1-17 is set to 1.  |
| <b>Cause</b>  |             | <b>Possible Solution</b>  |
| When the feedback deviates from the setpoint at a level greater than P1-15, for a time set in P1-16. This is effective only when P1-17 is set to 1 (alarm). |             | <ul style="list-style-type: none"> <li>Check for a blocked impeller, over cycling, or broken pipe.</li> <li>Set the Not Maintaining Setpoint alarm characteristics in P1-16 and P1-17.</li> <li>Drive response to this condition is controlled by P1-17, Not Maintaining Setpoint Selection.</li> </ul> |

| LED Display                             | LCD Display | Minor Fault Name   |
|---|-------------|--|
| oH                                      | oH          | Heatsink Overheat  |
|   |             | The temperature of the heatsink exceeded the overheat pre-alarm level set to L8-02.  |
| <b>Cause</b>                            |             | <b>Possible Solution</b>   |
| Surrounding temperature is too high     |             | <ul style="list-style-type: none"> <li>Check the surrounding temperature.</li> <li>Improve the air circulation within the enclosure panel.</li> <li>Install a fan or air conditioner to cool surrounding area.</li> <li>Remove anything near drive that may cause extra heat.</li> </ul>   |
| Internal cooling fan has stopped.       |             | <ul style="list-style-type: none"> <li>Replace the cooling fan.</li> <li>After replacing the drive, set parameter o4-03 to 0 to reset the cooling fan operation time.</li> </ul>   |
| Airflow around the drive is restricted. |             | <ul style="list-style-type: none"> <li>Provide proper installation space around the drive as indicated in the manual. <i>Refer to Installation Orientation and Spacing on page 28</i> for details.</li> <li>Allow for the proper space and ensure that there is sufficient circulation around the control panel.</li> <li>Check for dust or other foreign materials clogging the cooling fan.</li> <li>Clear debris caught in the fan that restricts air circulation.</li> </ul> |

| LED Display  | LCD Display | Minor Fault Name   |
|--|-------------|--|
| oH2  | oH2         | Drive Overheat Warning   |
|  |             | “Drive Overheat Warning” was input to a multi-function input terminal, S1 through S7 (H1-□□= B). |
| <b>Cause</b>   |             | <b>Possible Solution</b>   |
| An external device triggered an overheat warning in the drive. |             | Search for the device that tripped the overheat warning. Remove the cause of the problem.        |

| LED Display  | LCD Display | Minor Fault Name   |
|--|-------------|--|
| oH3  | oH3         | Motor Overheat   |
|  |             | The motor overheat signal entered to a multi-function analog input terminal exceeded the alarm level (H3-02 or H3-10 = E).   |
| <b>Cause</b>   |             | <b>Possible Solutions</b>  |
| Motor thermostat wiring is faulty (PTC input).                         |             | Repair the PTC input wiring.   |
| There is a fault on the machine side (e.g., the machine is locked up). |             | <ul style="list-style-type: none"> <li>Check the status of the machine.</li> <li>Remove the cause of the fault.</li> </ul>   |
| Motor has overheated.  |             | <ul style="list-style-type: none"> <li>Check the load size, accel/decel times, and cycle times.</li> <li>Decrease the load.</li> <li>Increase accel and decel times (C1-01 to C1-04).</li> <li>Adjust the preset V/f pattern (E1-04 through E1-10). This involves reducing E1-08 and E1-10. <ul style="list-style-type: none"> <li><b>Note:</b> Refrain from lowering E1-08 and E1-10 excessively to prevent a reduction in load tolerance at low speeds.</li> </ul> </li> <li>Check the motor-rated current.</li> <li>Enter motor-rated current on motor nameplate (E2-01).</li> <li>Ensure the motor cooling system is operating normally.</li> <li>Repair or replace the motor cooling system.</li> </ul> |

| LED Display       | LCD Display | Minor Fault Name                                 |
|-------------------|-------------|--|
| oL 1              | oL1         | Motor Overload                                   |
|                   |             | The electronic motor overload protection tripped |
| <b>Cause</b>      |             | <b>Possible Solution</b>                         |
| Load is too heavy |             | Reduce the load.                                 |

## 6.4 Alarm Detection

| LED Display   | LCD Display | Minor Fault Name  |
|---|-------------|---|
| Cycle times are too short during acceleration and deceleration                                    |             | Increase the acceleration and deceleration times (C1-01 through C1-04).   |
| A general-purpose motor is driven below the rated speed with a high load                          |             | <ul style="list-style-type: none"> <li>Reduce the load.</li> <li>Increase the speed.</li> <li>If the motor is supposed to operate at low speeds, either increase the motor capacity or use a motor specifically designed to operate in the desired speed range.</li> </ul>  |
| The output voltage is too high  |             | <ul style="list-style-type: none"> <li>Adjust the user-set V/f pattern (E1-04 through E1-10) by reducing E1-08 and E1-10.</li> <li>Do not set E1-08 and E1-10 too low. This reduces load tolerance at low speeds.</li> </ul>  |
| The wrong motor rated current is set to E2-01   |             | <ul style="list-style-type: none"> <li>Check the motor-rated current.</li> <li>Enter the motor rated current to parameter E2-01 as indicated on the motor nameplate.</li> </ul>   |
| The base frequency is set incorrectly   |             | <ul style="list-style-type: none"> <li>Check the rated frequency indicated on the motor nameplate.</li> <li>Enter the rated frequency to E1-06 (Base Frequency).</li> </ul>   |
| The electrical thermal protection characteristics and motor overload characteristics do not match |             | <ul style="list-style-type: none"> <li>Check the motor characteristics.</li> <li>Correct the type of motor protection that has been selected (L1-01).</li> <li>Install an external thermal relay.</li> </ul>  |
| The electrical thermal relay is operating at the wrong level                                      |             | <ul style="list-style-type: none"> <li>Check the current rating listed on the motor nameplate.</li> <li>Check the value set for the motor rated current (E2-01).</li> </ul>   |
| Motor overheated by overexcitation operation  |             | <ul style="list-style-type: none"> <li>Overexcitation increases the motor loss and the motor temperature. Excessive duration of overexcitation may cause motor damage. Prevent excessive overexcitation operation or apply proper cooling to the motor.</li> <li>Reduce the excitation deceleration gain (n3-13).</li> <li>Set L3-04 (Stall Prevention during Deceleration) to a value other than 4.</li> </ul> |
| Parameters related to Speed Search are set incorrectly  |             | <ul style="list-style-type: none"> <li>Check values set to Speed Search related parameters.</li> <li>Adjust the Speed Search current and Speed Search deceleration times (b3-02 and b3-03 respectively).</li> <li>After Auto-Tuning, set b3-24 to 1 to enable Speed Estimation Speed Search.</li> </ul>   |
| Output current fluctuation due to power supply loss   |             | Check the power supply for phase loss.  |

| LED Display  | LCD Display | Minor Fault Name   |
|--|-------------|--|
| OL2  | OL2         | Drive Overload   |
|  |             | The thermal sensor of the drive triggered overload protection.   |
| <b>Cause</b>   |             | <b>Possible Solution</b>   |
| Load is too heavy                                      |             | Reduce the load.   |
| Acceleration or deceleration time is too short         |             | Increase the settings for the acceleration and deceleration times (C1-01 through C1-04).   |
| The output voltage is too high                         |             | <ul style="list-style-type: none"> <li>Adjust the preset V/f pattern (E1-04 through E1-10) by reducing E1-08 and E1-10.</li> <li>Do not lower E1-08 and E1-10 excessively. This reduces load tolerance at low speeds.</li> </ul>   |
| Drive capacity is too small                            |             | Replace the drive with a larger model.   |
| Overload occurred when operating at low speeds         |             | <ul style="list-style-type: none"> <li>Reduce the load when operating at low speeds.</li> <li>Replace the drive with a model that is one frame size larger.</li> <li>Lower the carrier frequency (C6-02).</li> </ul>   |
| Excessive torque compensation                          |             | Reduce the torque compensation gain in parameter C4-01 until there is less current but no speed loss.  |
| Parameters related to Speed Search are set incorrectly |             | <ul style="list-style-type: none"> <li>Check the settings for all Speed Search related parameters.</li> <li>Adjust the current used during Speed Search (b3-03) and the Speed Search deceleration time (b3-02).</li> <li>After Auto-Tuning, set b3-24 to 1 to enable Speed Estimation Speed Search.</li> </ul> |
| Output current fluctuation due to input phase loss     |             | Check the power supply for phase loss.   |

| LED Display  | LCD Display | Minor Fault Name  |
|--|-------------|---|
| OL3  | OL3         | Overtorque Detection 1  |
|  |             | The current has exceeded the value set for torque detection (L6-02) for longer than the allowable time (L6-03). |
| <b>Cause</b>   |             | <b>Possible Solution</b>  |
| Parameter settings are not appropriate for the load    |             | Check L6-02 and L6-03 settings.   |
| Fault on the machine side (e.g., machine is locked up) |             | Check the status of the load. Remove the cause of the fault.  |

| LED Display   | LCD Display | Minor Fault Name  |
|---|-------------|---|
| OL4   | OL4         | Overtorque Detection 2<br>The current has exceeded the value set for Overtorque Detection 2 (L6-05) for longer than the allowable time (L6-06). |
| <b>Cause</b>  |             | <b>Possible Solution</b>  |
| Parameter settings are not appropriate for the load |             | Check the settings of parameters L6-05 and L6-06.   |

| LED Display   | LCD Display | Minor Fault Name  |
|---|-------------|---|
| OU  | OV          | DC Bus Overvoltage<br>The DC bus voltage exceeded the trip point.<br>• For 200 V class drives: approximately 410 V<br>• For 400 V class drives: approximately 820 V (740 V when E1-01 < 400)  |
| <b>Cause</b>  |             | <b>Possible Solutions</b>   |
| Surge voltage present in the drive input power.                                       |             | <ul style="list-style-type: none"> <li>Install a DC link choke or an AC reactor.</li> <li>Voltage surge can result from a thyristor convertor and a phase advancing capacitor operating on the same drive input power system.</li> </ul>  |
| The motor is short-circuited.   |             | <ul style="list-style-type: none"> <li>Check the motor power cable, relay terminals and motor terminal box for short circuits.</li> <li>Correct grounding shorts and turn the power back on.</li> </ul>   |
| Ground current has overcharged the main circuit capacitors via the drive input power. |             |   |
| Noise interference causes the drive to operate incorrectly.                           |             | <ul style="list-style-type: none"> <li>Review possible solutions for handling noise interference.</li> <li>Review section on handling noise interference and check control circuit lines, main circuit lines and ground wiring.</li> <li>If the magnetic contactor is identified as a source of noise, install a surge protector to the MC coil.</li> </ul> |
|   |             | Set number of fault restarts (L5-01) to a value other than 0.   |

| LED Display   | LCD Display                        | Minor Fault Name   |
|---|------------------------------------|--|
| PCYC  | PUMP Cycling<br>PUMP Over<br>Cycle | Pump Over Cycle  |
| <b>Cause</b>  |                                    | <b>Possible Solution</b>   |
| The pump has exceeded the number of cycles set in P2-10 in the time set in P2-11 and P2-12 is set to 1 (alarm). |                                    | <ul style="list-style-type: none"> <li>Set the Pump Over Cycle alarm characteristics in P2-10 and P2-11.</li> <li>Drive response to this condition is controlled by P2-12, Over Cycling Mode.</li> </ul> |

| LED Display   | LCD Display | Minor Fault Name                                 |
|---|-------------|--|
| rdd   | R-DNE-S□    | Remote Drive Disable                             |
| <b>Cause</b>  |             | <b>Possible Solution</b>                         |
| Terminal S□ (H1-0□ = 95) has been closed for the time set in P4-26, Remote Drive Disable On-Delay, when P4-25, Remote Drive Disable Selection, was set to 0 (N.O.). |             | Remove conditions causing the terminal to close. |
| Terminal S□ (H1-0□ = 95) has been open for the time set in P4-26, Remote Drive Disable On-Delay, when P4-25, Remote Drive Disable Selection, was set to 1 (N.C.).   |             | Remove conditions causing the terminal to open.  |

| LED Display  | LCD Display | Minor Fault Name   |
|--|-------------|--|
| SE   | SE          | MEMOBUS/Modbus Communication Test Mode Error<br><b>Note:</b> This alarm will not trigger a multi-function output terminal that is set for alarm output (H2-□□ = 10). |
| <b>Cause</b>   |             | <b>Possible Solution</b>   |
| A digital input set to 67H (MEMOBUS/Modbus test) was closed while the drive was running. |             | Stop the drive and run the test again.   |

| LED Display  | LCD Display | Minor Fault Name         |
|--------------|-------------|--------------------------|
| tdE          | TdE         | Time Data Error          |
| <b>Cause</b> |             | <b>Possible Solution</b> |

## 6.4 Alarm Detection

| LED Display  | LCD Display                | Minor Fault Name  |
|--|----------------------------|---|
| An error has occurred in the Real-Clock Time function of the HOA keypad.   |                            | Replace the HOA keypad. For instructions on replacing the HOA keypad, contact Yaskawa or your nearest sales representative.   |
| LED Display  | LCD Display                | Minor Fault Name  |
| ErPC   | TrPC                       | IGBT Maintenance Time (90%)<br>IGBTs have reached 90% of their expected performance life.   |
| <b>Cause</b>   |                            | <b>Possible Solution</b>  |
| IGBTs have reached 90% of their expected performance life.   |                            | Replace the drive.  |
| LED Display  | LCD Display                | Minor Fault Name  |
| UL3  | UL3                        | Undertorque Detection 1<br>The current has fallen below the minimum value set for torque detection (L6-02) for longer than the allowable time (L6-03).  |
| <b>Cause</b>   |                            | <b>Possible Solution</b>  |
| Parameter settings are not appropriate for the load  |                            | Check the settings of parameters L6-02 and L6-03.   |
| There is a fault on the machine side   |                            | Check the load for any problems.  |
| LED Display  | LCD Display                | Minor Fault Name  |
| UL4  | UL4                        | Undertorque Detection 2<br>The current has fallen below the minimum value set for torque detection (L6-05) for longer than the allowable time (L6-06).  |
| <b>Cause</b>   |                            | <b>Possible Solution</b>  |
| Parameter settings are not appropriate for the load  |                            | Check L6-05 and L6-06 settings  |
| There is a fault on the machine side   |                            | Check the load for any problems.  |
| LED Display  | LCD Display                | Minor Fault Name  |
| UL6  | UL6<br>Underload Det.<br>6 | Motor Underload<br>The load has fallen below the underload curve defined in L6-14.  |
| <b>Cause</b>   |                            | <b>Possible Solution</b>  |
| The output current has fallen below the motor underload curve defined in L6-14 for longer than the time set to L6-03 |                            | Adjust the value set to L6-14 so that output current remains above the motor underload curve during normal operation.   |
| LED Display  | LCD Display                | Minor Fault Name  |
| UU   | UU                         | Undervoltage<br>One of the following conditions was true when the drive was stopped and a Run command was entered:<br>• DC bus voltage dropped below the level specified in L2-05.<br>• Contactor to suppress inrush current in the drive was opened.<br>• Low control drive input power voltage. This alarm outputs if L2-01 ≠ 0 and DC bus voltage < L2-05. |
| <b>Cause</b>   |                            | <b>Possible Solution</b>  |
| Phase loss in the drive input power.   |                            | Check for wiring errors in the main circuit drive input power. Correct the wiring.  |
| Loose wiring in the drive input power terminals.   |                            | • Ensure the terminals have been properly tightened.<br>• Apply the tightening torque to the terminals as specified. <i>Refer to Wire Gauges and Tightening Torques on page 50</i> for details.   |
| There is a problem with the drive input power voltage.   |                            | • Check the voltage.<br>• Lower the voltage of the drive input power so that it is within the limits listed in the specifications.  |
| Drive internal circuitry is worn.  |                            | • Check the maintenance time for the capacitors (U4-05).<br>• Replace the drive if U4-05 exceeds 90%.   |
| The drive input power transformer is too small and voltage drops when the power is switched on.                      |                            | • Check for an alarm when the magnetic contactor, line breaker, and leakage breaker are closed.<br>• Check the capacity of the drive input power transformer.   |

| LED Display                             | LCD Display | Minor Fault Name                        |
|---|-------------|---|
| Air inside the drive is too hot.        |             | Check the temperature inside the drive. |
| CHARGE light is broken or disconnected. |             | Replace the drive.                      |

## 6.5 Operator Programming Errors

### ◆ Operator Programming Error Codes, Causes, and Possible Solutions

An Operator Programming Error (oPE) occurs when a contradictory parameter is set or an individual parameter is set to an inappropriate value.

The drive will not operate until the parameter or parameters causing the problem are set correctly. An oPE, however, does not trigger an alarm or fault output. If an oPE occurs, investigate the cause and refer to [Table 6.4](#) for the appropriate action. When an oPE appears on the operator display, press the ENTER button to view U1-18 and see which parameter is causing the oPE.

**Table 6.4 oPE Codes, Causes, and Possible Solutions**

| LED Display  | LCD Display | Error Name   |
|--|-------------|--|
| oPE01  | oPE01       | Drive Capacity Setting Fault   |
|  |             | Drive capacity and the value set to o2-04 do not match.  |
| <b>Cause</b>   |             | <b>Possible Solutions</b>  |
| The drive model selection (o2-04) and the actual capacity of the drive are not the same.   |             | Correct the value set to o2-04.  |
| LED Display  | LCD Display | Error Name   |
| oPE02  | oPE02       | Parameter Range Setting Error  |
|  |             | Use U1-18 to find parameters set outside the range.  |
| <b>Cause</b>   |             | <b>Possible Solutions</b>  |
| Parameters were set outside the possible setting range.  |             | Set parameters to the proper values.   |
| <b>Note:</b> When multiple errors occur simultaneously, other errors are given precedence over oPE02.  |             |  |
| LED Display  | LCD Display | Error Name   |
| oPE03  | oPE03       | Multi-Function Input Selection Error   |
|  |             | A contradictory setting is assigned to multi-function contact inputs H1-01 to H1-07.   |
| <b>Cause</b>   |             | <b>Possible Solutions</b>  |
| <ul style="list-style-type: none"> <li>The same function is assigned to two multi-function inputs.</li> <li>Excludes “Not used” and “External Fault.”</li> </ul>   |             | <ul style="list-style-type: none"> <li>Ensure all multi-function inputs are assigned to different functions.</li> <li>Re-enter the multi-function settings to ensure this does not occur.</li> </ul> |
| The Up command was set but the Down command was not, or vice versa (settings 10 vs. 11).   |             | Properly set the functions that required for use in combination with other functions.  |
| The Up 2 command was set but the Down 2 command was not, or vice versa (settings 75 vs. 76).   |             |  |
| <ul style="list-style-type: none"> <li>Run/Stop command for a 2-wire sequence was set (H1-□□ = 42), but Forward/Reverse command (H1-□□ = 43) was not.</li> <li>“Drive Enable” is set to multi-function input S1 or S2 (H1-01 = 6A or H1-02 = 6A).</li> </ul>           |             | Properly set the functions that required for use in combination with other functions.  |
| Two of the following functions are set simultaneously: <ul style="list-style-type: none"> <li>Up/Down Command (10 vs. 11)</li> <li>Up 2/Down 2 Command (75 vs. 76)</li> <li>Hold Accel/Decel Stop (A)</li> <li>Analog Frequency Reference Sample/ Hold (1E)</li> </ul> |             | <ul style="list-style-type: none"> <li>Check if contradictory settings have simultaneously been assigned to the multi-function input terminals.</li> <li>Correct setting errors.</li> </ul>          |
| The Up/Down command (10, 11) and PID control (b5-01) are enabled simultaneously.   |             | Set b5-01 to 0 to disable control PID or disable the Up/Down command.  |



| LED Display  | LCD Display | Error Name  |
|--|-------------|---|
| Settings for N.C. and N.O. input for the following functions were selected simultaneously:<br><ul style="list-style-type: none"> <li>External Search Command 1 and External Search Command 2 (61 vs. 62)</li> <li>Fast Stop N.O. and Fast Stop N.C. (15 vs. 17)</li> <li>KEB Command 1 and KEB Command 2 (65, 66 vs. 7A, 7B)</li> <li>FWD Run Command (or REV) and FWD/REV Run Command (2-wire) (40, 41 vs. 42, 43)</li> <li>External DB Command and Drive Enable (60 vs. 6A)</li> </ul> |             | <ul style="list-style-type: none"> <li>Check if contradictory settings have simultaneously been assigned to the multi-function input terminals.</li> <li>Correct setting errors.</li> </ul> |
| One of the following settings was entered while H1-□□ = 2 (External Reference 1/2):<br><ul style="list-style-type: none"> <li>b1-15 = 4 (Pulse Train Input) but the pulse train input selection is not set for the frequency reference (H6-01 &gt; 0)</li> <li>b1-15 or b1-16 set to 3 but no option card is connected</li> <li>Although b1-15 = 1 (Analog Input) and H3-02 or H3-10 are set to 0 (Frequency Bias)</li> </ul>  |             | Correct the settings for the multi-function input terminal parameters.  |
| H2-□□ is set to 38 (Drive Enabled) and H1-□□ is not set to 6A (Drive Enable).  |             |   |

| LED Display   | LCD Display | Error Name   |
|---|-------------|--|
| PE04  | PE04        | Initialization Required, Term <-> Ctrl Chg   |
| <b>Cause</b>  |             | <b>Possible Solutions</b>  |
| The drive, control board, or terminal board have been replaced and the parameter settings between the control board and the terminal board no longer match. |             | <ul style="list-style-type: none"> <li>Set A1-03 to 5550 to load the parameter settings stored in the terminal board to the drive.</li> <li>Initialize parameters after drive replacement by setting A1-03 to 1110 or 2220.</li> </ul> |

| LED Display   | LCD Display | Error Name   |
|---|-------------|--|
| PE05  | PE05        | Run Command/Frequency Reference Source Selection Error |
| <b>Cause</b>  |             | <b>Possible Solutions</b>                              |
| Frequency reference is assigned to an option card (b1-01 = 3) and an input option card is not connected to the drive.                     |             | Reconnect the input option card to the drive.          |
| The Run command is assigned to an option card (b1-02 = 3) and an input option card is not connected to the drive.                         |             |  |
| Frequency reference is assigned to the pulse train input (b1-01 = 4) and terminal RP is not set for frequency reference input (H6-01 > 0) |             | Set H6-01 to 0.  |

| LED Display                                | LCD Display | Error Name  |
|--|-------------|---|
| PE07                                       | PE07        | Multi-Function Analog Input Selection Error   |
|  |             | A contradictory setting is assigned to multi-function analog inputs H3-02 or H3-10 and PID functions conflict.  |
| <b>Cause</b>                               |             | <b>Possible Solutions</b>   |
| H3-02 and H3-10 are set to the same value. |             | Change the settings to H3-02 or H3-10 so that functions no longer conflict.<br><b>Note:</b> Both 0 (Frequency Reference Bias) and F (Not Used) can be set to H3-02 or H3-10 simultaneously. |

## 6.5 Operator Programming Errors

| LED Display   | LCD Display | Error Name                         |
|---|-------------|------------------------------------|
| The following simultaneous contradictory settings:<br><ul style="list-style-type: none"> <li>H3-02 or H3-06 = B (PID Feedback) while H6-01 (Pulse Train Input) = 1 (PID Feedback)</li> <li>H3-02 or H3-06 = C (PID Target Value) while H6-01 = 2 (pulse train input sets the PID target value)</li> </ul> |             | Disable one of the PID selections. |

| LED Display  | LCD Display  | Error Name   |
|--|--------------|--|
| <b>oPE09</b>   | <b>oPE09</b> | PID Control Selection Fault  |
|  |              | PID control function selection is incorrect. Requires that PID control is enabled (b5-01 = 1). |
| <b>Cause</b>   |              | <b>Possible Solutions</b>  |
| b5-01 is set to 1 or 2, enabling PID control, but the lower limit for the frequency reference (d2-02) is not set to 0 while reverse output is enabled (b5-11 = 1). |              | Correct the parameter settings.  |

| LED Display                | LCD Display  | Error Name  |
|----------------------------|--------------|---|
| <b>oPE 10</b>              | <b>oPE10</b> | V/f Data Setting Error  |
|                            |              | One of the following setting errors has occurred:<br>$E1-09 \leq E1-07 < E1-06 \leq E1-11 \leq E1-04$ |
| <b>Cause</b>               |              | <b>Possible Solutions</b>   |
| V/f pattern setting error. |              | Correct the settings for E1-04, E1-06, E1-07, E1-09, and E1-11.                                       |

| LED Display   | LCD Display  | Error Name                                     |
|---|--------------|--|
| <b>oPE 11</b>   | <b>oPE11</b> | Carrier Frequency Setting Error                |
|   |              | Correct the setting for the carrier frequency. |
| <b>Cause</b>  |              | <b>Possible Solutions</b>                      |
| The following simultaneous contradictory settings have occurred: C6-05 > 6 and C6-04 > C6-03 (carrier frequency lower limit is greater than the upper limit).<br>If C6-05 ≤ 6, the drive operates at C6-03. |              | Correct the parameter settings.                |
| The upper and lower limits between C6-02 and C6-05 are contradictory.   |              |  |

| LED Display   | LCD Display                            | Error Name  |
|---|--|---|
| <b>oPE33</b>  | <b>oPE33<br/>Net.<br/>Incompatible</b> | Parameter selection is incompatible with the selected network P9-99 |
| <b>Cause</b>  |  | <b>Possible Solutions</b>   |
| When P1-01 = 3 (MEMOBUS Networking) and P9-99 = 0 (A-Version 30034), one of the following parameters has been set:<br><ul style="list-style-type: none"> <li>P9-01 = 2 (Stop History)</li> <li>P9-05 = 3 (Follow Lead Speed)</li> </ul> |  | Confirm parameter settings for P1-01, P9-01, P9-99, and P9-05.      |

## 6.6 Copy Function Related Displays

### ◆ Tasks, Errors, and Troubleshooting

The table below lists the messages and errors that may appear when using the Copy function.

When executing the tasks offered by the Copy function, the keypad will indicate the task being performed. When an error occurs, a code appears on the keypad to indicate the error. Note that errors related to the Copy function do not trigger a multi-function output terminal that has been set up to close when a fault or alarm occurs. To clear an error, simply press any key on the keypad and the error display will disappear.

**Table 6.5** lists the corrective action that can be taken when an error occurs.

- Note:**
1. The drive should be fully stopped when using the copy function.
  2. The drive will not accept a Run command while the Copy function is being executed.
  3. Parameters can only be saved to a drive when the voltage class, capacity, control mode, and software version match.

**Table 6.5 Copy Function Task and Error Displays**

| LED Display   | LCD Display | Task  |
|---|-------------|---|
| <i>COPY</i>   | CoPy        | Writing Parameter Settings (flashing)   |
| <b>Cause</b>  |             | <b>Possible Solutions</b>   |
| Parameters are being written to the drive.  |             | This is not an error.   |
| LED Display   | LCD Display | Task  |
| <i>CPyE</i>   | CoPyE       | Error Writing Data  |
| <b>Cause</b>  |             | <b>Possible Solutions</b>   |
| Failed writing parameters   |             | Attempt to write parameters again.  |
| LED Display   | LCD Display | Task  |
| <i>CSEr</i>   | CSEr        | Copy Unit Error   |
| <b>Cause</b>  |             | <b>Possible Solutions</b>   |
| Hardware fault  |             | Replace the HOA keypad or the USB Copy Unit.  |
| LED Display   | LCD Display | Task  |
| <i>dFPS</i>   | dFPS        | Drive Model Mismatch  |
| <b>Cause</b>  |             | <b>Possible Solutions</b>   |
| The drives used in the copy and write process are not the same model.   |             | <ul style="list-style-type: none"> <li>• Verify the model number of the drive from which the parameters were copied and the model of the drive to which those parameters will be written.</li> <li>• Make sure the two drives are the same model and have the same software version.</li> </ul> |
| <ul style="list-style-type: none"> <li>• The drive from which the parameters were copied is a different model.</li> <li>• The drive to be written to is a different model.</li> </ul> |             |   |
| LED Display   | LCD Display | Task  |
| <i>End</i>  | End         | Task Complete   |
| <b>Cause</b>  |             | <b>Possible Solutions</b>   |
| Finished reading, writing, or verifying parameters.   |             | This is not an error.   |
| LED Display   | LCD Display | Task  |
| <i>iFEr</i>   | iFEr        | Communication Error   |
| <b>Cause</b>  |             | <b>Possible Solutions</b>   |
| A communication error occurred between the drive and the HOA keypad or the USB copy unit.   |             | Check the cable connection.   |
| A non-compatible cable is being used to connect the USB Copy Unit and the drive.  |             | Use the cable originally packaged with the USB Copy Unit.   |

## 6.6 Copy Function Related Displays

| LED Display  | LCD Display | Task  |
|--|-------------|---|
| <b>ndRt</b>  | <b>ndAT</b> | Model, Voltage Class, Capacity Mismatch   |
| <b>Cause</b>   |             | <b>Possible Solutions</b>   |
| The drive from which the parameters were copied and the drive to which the parameters will be written have different electrical specifications, capacities, are set to different control modes, or are different models. |             | Make sure model numbers and specifications are the same for both drives.  |
| The device being used to write the parameters is blank and does not have any parameters saved on it.   |             | Make sure all connections are correct, and copy the parameter settings onto the USB Copy Unit or the HOA keypad.  |
| LED Display  | LCD Display | Task  |
| <b>rdEr</b>  | <b>rdEr</b> | Error Reading Data  |
| <b>Cause</b>   |             | <b>Possible Solutions</b>   |
| Failed while attempting to read parameter settings from the drive.   |             | Press and hold the READ key on the USB Copy Unit for at least one second to have the unit read parameters from the drive.   |
| LED Display  | LCD Display | Task  |
| <b>rERd</b>  | <b>rERd</b> | Reading Parameter Settings (flashing)   |
| <b>Cause</b>   |             | <b>Possible Solutions</b>   |
| Displayed while the parameter settings are being read onto the USB Copy Unit.  |             | This is not an error.   |
| LED Display  | LCD Display | Task  |
| <b>vAEr</b>  | <b>vAEr</b> | Voltage Class, Capacity Mismatch  |
| <b>Cause</b>   |             | <b>Possible Solutions</b>   |
| The drive from which the parameters were copied and the drive on which the Verify mode is being performed have different electrical specifications or are a different capacity.  |             | Make sure electrical specifications and capacities are the same for both drives.  |
| LED Display  | LCD Display | Task  |
| <b>vFyE</b>  | <b>vFyE</b> | Parameter settings in the drive and those saved to the copy function are not the same   |
| <b>Cause</b>   |             | <b>Possible Solutions</b>   |
| Indicates that parameter settings that have been Read and loaded onto the Copy Unit or HOA keypad are different.   |             | To synchronize parameters, either write the parameters saved on the USB Copy Unit or HOA keypad onto the drive, or Read the parameter settings on the drive onto the USB Copy Unit. |
| LED Display  | LCD Display | Task  |
| <b>vRFy</b>  | <b>vRFy</b> | Comparing Parameter Settings (flashing)   |
| <b>Cause</b>   |             | <b>Possible Solutions</b>   |
| The Verify mode has confirmed that parameters settings on the drive and parameters read to the copy device are identical.  |             | This is not an error.   |

## 6.7 Digital Operator Display Messages


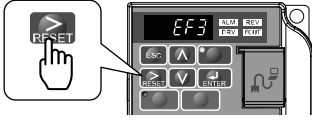


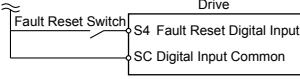
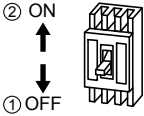
Table 6.6 lists messages and errors that may appear during normal pump operation.

These messages do not trigger multi-function output terminals that have been set up to close when a fault or alarm occurs.

**Table 6.6 Digital Operator Display Messages**

| LED Display   | LCD Display  | Description   |
|---------------|--|---|
| CrSt          | CrST<br>Cannot Reset                               | Fault reset was being executed when a Run command was entered. Ensure that a Run command cannot be entered from the external terminals or option during fault reset. Turn off the Run command.                                  |
| CUr           | Current Limit Foldback                             | Displayed when drive output speed is being limited due to the output current limit. Reduce the load or replace with higher capacity drive.  |
| dStGE         | De-staging in X sec                                | Displayed during multiplexing when drive de-staging is in progress. X sec indicates the time left before the de-staging takes place.  |
| no indication | DigitalOut Delay Active                            | Displayed when the Digital Output Delay function is active.   |
| FbCH-         | Feedback Drop Check                                | Displayed when the drive is determining whether the feedback will change abruptly when the drive enters Sleep Mode. Drop Level is configured by P2-08, Delta Sleep Feedback Drop Level, and P2-09 Feedback Detection Drop Time. |
| LoC-P         | LOCK<br>Parameter Locked                           | Displayed after an attempt to change a parameter when A1-01 = 3. Unlock the keypad by setting A1-01 = 2.  |
| no indication | Lube Pump Active                                   | Displayed when the Lube Pump digital output is energized.   |
| nEtEr         | Net Pump Err<br>Chk Faulted Pump                   | Displayed when the drive has been stopped because another drive in the network has a system fault or a Low City Pressure alarm.   |
| nEtSt         | Net Start Delay<br>P9-29 Active                    | Displayed when the MEMOBUS network is waiting for the P9-29 timer to elapse.  |
| nEtFb         | Network FB Lost<br>Check FB Source                 | Displayed when no valid analog PID feedback source can be found on the network and network PID feedback has been lost.  |
| PASS          | PASS<br>MEMOBUS/Modbus Comm.<br>Test Mode Complete | MEMOBUS/Modbus test has finished normally.  |
| PrCHG         | Pre Chg Mode<br>Exit in Xsec                       | Pre-charge 1 or 2 active. X indicates time left before pre-charge exits due to timers (P4-03 + P4-07).  |
| IPH           | Single Phase Foldback                              | Displayed when an input phase has been lost, or when excess load is being drawn by the motor in a single phase application.   |
| SLEEP         | Sleep Active Wait for<br>Start                     | Displayed when the drive is in Sleep Mode or when the drive is waiting for the feedback level to reach the level set in P1-04, Start Level.   |
| booSt         | Sleep Boost Active                                 | Displayed when the drive entering Sleep Mode and the pressure setpoint is being boosted. During this time, the U1-01, Frequency Reference, monitor will be updated with the boosted setpoint.                                   |
| StAGE         | Staging in X sec                                   | Displayed during multiplexing when drive staging is in progress. X sec indicates the time left before the staging takes place.  |
| UJA It        | Start Delay Adjust b1-11                           | Displayed when the drive start is being delayed by Coast to Stop with Timer (Back Spin Timer). This time is adjusted by parameter b1-11, Coast to Stop with Timer Time.   |
| UJA It        | Start Delay Timer Active                           | Displayed when the feedback level has reached the level set in P1-04, Start Level, and the Start Delay timer is incrementing.   |
| ThrSt         | Thrust Mode<br>Thrust Active                       | Displayed during Thrust Mode.   |
| Ut IL         | Utility Delay Adjust by<br>P4-17                   | Displayed when the drive is delaying the Run command due to the Utility Start Delay Function.   |

### ◆ Fault Reset Methods

| After the Fault Occurs   | Procedure   |   |
|--|---|---|
| Fix the cause of the fault, restart the drive, and reset the fault   | Press  on the digital operator.    |  |
|  | Press  on the optional HOA keypad. |  |
| Fix the cause of the fault and reset via Fault Reset Digital Input S4.   | Close then open the fault signal digital input via terminal S4. S4 is set fault reset as default (H1-04 = 12).      |  |
| Turn off the main power supply if the above methods do not reset the fault. Reapply power after the digital operator display has turned off. |                                  |   |

# Periodic Inspection & Maintenance

---

This chapter describes the periodic inspection and maintenance of the drive to ensure that it receives the proper care to maintain overall performance.

|            |                                  |            |
|------------|----------------------------------|------------|
| <b>7.1</b> | <b>SECTION SAFETY.....</b>       | <b>288</b> |
| <b>7.2</b> | <b>INSPECTION.....</b>           | <b>290</b> |
| <b>7.3</b> | <b>PERIODIC MAINTENANCE.....</b> | <b>292</b> |
| <b>7.4</b> | <b>DRIVE COOLING FANS.....</b>   | <b>294</b> |
| <b>7.5</b> | <b>DRIVE REPLACEMENT.....</b>    | <b>301</b> |

## 7.1 Section Safety

### DANGER

#### Electrical Shock Hazard

**Do not connect or disconnect wiring while the power is on.**

Failure to comply will result in death or serious injury.

### WARNING

#### Electrical Shock Hazard

**Do not operate equipment with covers removed.**

Failure to comply could result in death or serious injury.

The diagrams in this section may show drives without covers or safety shields to show details. Be sure to reinstall covers or shields before operating the drives and run the drives according to the instructions described in this manual.

**Always ground the motor-side grounding terminal.**

Improper equipment grounding could result in death or serious injury by contacting the motor case.

**Do not remove covers or touch circuit boards while the power is on.**

Failure to comply could result in death or serious injury.

**Do not allow unqualified personnel to perform work on the drive.**

Failure to comply could result in death or serious injury.

Installation, maintenance, inspection, and servicing must be performed only by authorized personnel familiar with installation, adjustment, and maintenance of AC drives.

**Do not perform work on the drive while wearing loose clothing, jewelry or without eye protection.**

Failure to comply could result in death or serious injury.

Remove all metal objects such as watches and rings, secure loose clothing, and wear eye protection before beginning work on the drive.

**Do not touch any terminals before the capacitors have fully discharged.**

Failure to comply could result in death or serious injury.

Before wiring terminals, disconnect all power to the equipment. The internal capacitor remains charged even after the power supply is turned off. The charge indicator LED will extinguish when the DC bus voltage is below 50 Vdc. To prevent electric shock, wait at least five minutes after all indicators are off and measure the DC bus voltage level to confirm safe level.

#### Fire Hazard

**Tighten all terminal screws to the specified tightening torque.**

Loose electrical connections could result in death or serious injury by fire due to overheating of electrical connections.

**Do not use an improper voltage source.**

Failure to comply could result in death or serious injury by fire.

Verify that the rated voltage of the drive matches the voltage of the incoming power supply before applying power.

**Do not use improper combustible materials.**

Failure to comply could result in death or serious injury by fire.

Attach the drive to metal or other noncombustible material.



**NOTICE**

**Observe proper electrostatic discharge procedures (ESD) when handling the drive and circuit boards.**

Failure to comply may result in ESD damage to the drive circuitry.

**Never connect or disconnect the motor from the drive while the drive is outputting voltage.**

Improper equipment sequencing could result in damage to the drive.

**Do not use unshielded cable for control wiring.**

Failure to comply may cause electrical interference resulting in poor system performance. Use shielded, twisted-pair wires and ground the shield to the ground terminal of the drive.

**Do not allow unqualified personnel to use the product.**

Failure to comply could result in damage to the drive or braking circuit.

Carefully review instruction manual TOBPC72060000 when connecting a braking option to the drive.

**Do not modify the drive circuitry.**

Failure to comply could result in damage to the drive and will void warranty.

Yaskawa is not responsible for any modification of the product made by the user. This product must not be modified.

**Check all the wiring to ensure that all connections are correct after installing the drive and connecting any other devices.**

Failure to comply could result in damage to the drive.

## 7.2 Inspection

Power electronics have limited life and may exhibit changes in characteristics or performance deterioration after years of use under normal conditions. To help avoid such problems, it is important to perform preventive maintenance and periodic inspection on the drive.

Drives contain a variety of power electronics such as power transistors, semiconductors, capacitors, resistors, fans, and relays. The electronics in the drive serve a critical role in maintaining proper motor control.

Follow the inspection lists provided in this chapter as a part of a regular maintenance program.

**Note:** The drive will require more frequent inspection if it is placed in harsh environments, such as:

- High ambient temperatures
- Frequent starting and stopping
- Fluctuations in the AC supply or load
- Excessive vibrations or shock loading
- Dust, metal dust, salt, sulfuric acid, chlorine atmospheres
- Poor storage conditions.

Perform the first equipment inspection one to two years after installation.

### ◆ Recommended Periodic Inspection

outlines the recommended periodic inspections for Yaskawa drive installations. Although periodic inspections should generally be performed once a year; the drive may require more frequent inspection in harsh environments or with rigorous use. Operating and environmental conditions, along with experience in each application, will determine the actual inspection frequency for each installation. Periodic inspection will help to avoid premature deterioration in performance or product failure. Copy this checklist and mark the “Checked” column after each inspection.

### ■ Periodic Inspection

**WARNING! Electrical Shock Hazard.** Do not connect or disconnect wiring while the power is on. Failure to comply can result in serious personal injury. Before servicing the drive, disconnect all power to the equipment. The internal capacitor remains charged even after the power supply is turned off. The charge indicator LED will extinguish when the DC bus voltage is below 50 Vdc. To prevent electric shock, wait at least five minutes after all indicators are OFF and measure the DC bus voltage level to confirm safe level.

Table 7.1 Periodic Inspection Checklist

| Inspection Area                            | Inspection Points   | Corrective Action   | Checked |
|--|---|---|---------|
| <b>Main Circuit Periodic Inspection</b>    |   |   |         |
| <b>General</b>                             | <ul style="list-style-type: none"> <li>• Overall check of the main power circuit and ground terminals</li> </ul>  | Take appropriate actions (e.g., tightening loose connections).  |         |
|  | <ul style="list-style-type: none"> <li>• Inspect equipment for discoloration from overheating or deterioration.</li> <li>• Inspect for damaged or deformed parts.</li> </ul>                                    | <ul style="list-style-type: none"> <li>• Replace damaged components as required.</li> <li>• The drive has few serviceable parts and may require complete drive replacement.</li> </ul>  |         |
|  | <ul style="list-style-type: none"> <li>• Inspect for dirt, foreign particles, or dust collection on components.</li> </ul>  | <ul style="list-style-type: none"> <li>• Inspect enclosure door seal if present. Replace components if cleaning is not possible.</li> <li>• Remove foreign particles and dust with a vacuum cleaner to avoid touching parts.</li> </ul> |         |
| <b>Conductors and Wiring</b>               | <ul style="list-style-type: none"> <li>• Inspect wiring and connections for discoloration, damage, or heat stress.</li> <li>• Inspect wire insulation and shielding for wear.</li> </ul>                        | <ul style="list-style-type: none"> <li>• Repair or replace damaged wiring.</li> </ul>   |         |
| <b>Terminals</b>                           | <ul style="list-style-type: none"> <li>• Inspect terminals for stripped, damaged, or loose connections.</li> </ul>  | <ul style="list-style-type: none"> <li>• Tighten loose screws and replace damaged screws or terminals.</li> </ul>   |         |
| <b>Relays and Contactors</b>               | <ul style="list-style-type: none"> <li>• Inspect contactors and relays for excessive noise during operation.</li> <li>• Inspect coils for signs of overheating such as melted or cracked insulation.</li> </ul> | <ul style="list-style-type: none"> <li>• Check coil voltage for over or under voltage conditions.</li> <li>• Replace damaged removable relays contactors or circuit board.</li> </ul>   |         |
| <b>Braking Resistors</b>                   | <ul style="list-style-type: none"> <li>• Inspect for discoloration of heat stress on or around resistors.</li> </ul>  | <ul style="list-style-type: none"> <li>• Minor discoloration may be acceptable.</li> <li>• If discoloration exists check for loose connections.</li> </ul>  |         |
| <b>Motor Periodic Inspection</b>           |   |   |         |
| <b>Operation Check</b>                     | <ul style="list-style-type: none"> <li>• Check for increased vibration or abnormal noise.</li> </ul>  | <ul style="list-style-type: none"> <li>• Stop the motor and contact qualified maintenance personnel as required.</li> </ul>   |         |
| <b>Control Circuit Periodic Inspection</b> |   |   |         |

| Inspection Area                           | Inspection Points  | Corrective Action  | Checked |
|---|--|--|---------|
| <b>General</b>                            | <ul style="list-style-type: none"> <li>Inspect terminals for stripped, damaged or loose connections.</li> <li>Check for tightness.</li> </ul>  | <ul style="list-style-type: none"> <li>Tighten loose screws and replace damaged screws or terminals.</li> <li>If terminals are integral to a circuit board then board or drive replacement may be required.</li> </ul> |         |
| <b>Cooling System Periodic Inspection</b> |  |  |         |
| <b>Cooling Fan</b>                        | <ul style="list-style-type: none"> <li>Check for abnormal oscillation or unusual noise.</li> <li>Check for damaged or missing fan blades.</li> </ul>   | <ul style="list-style-type: none"> <li>Replace as required.</li> <li><i>Refer to Drive Cooling Fans on page 294</i> for information on cleaning or replacing the cooling fan.</li> </ul>                               |         |
| <b>Heatsink</b>                           | <ul style="list-style-type: none"> <li>Inspect for dust or other foreign material collected on the surface.</li> </ul>   | <ul style="list-style-type: none"> <li>Remove foreign particles and dust with a vacuum cleaner to avoid touching parts.</li> </ul>   |         |
| <b>Air Duct</b>                           | <ul style="list-style-type: none"> <li>Inspect air intake and exhaust openings. They must be free from obstruction and properly installed.</li> </ul>  | <ul style="list-style-type: none"> <li>Visually inspect the area.</li> <li>Clear obstructions and clean air duct as required.</li> </ul>   |         |
| <b>LED Periodic Inspection</b>            |  |  |         |
| <b>LEDs</b>                               | <ul style="list-style-type: none"> <li>Make sure the LED lights correctly.</li> <li>Inspect for dust or other foreign material that may have collected on surrounding components.</li> </ul> | <ul style="list-style-type: none"> <li>Contact your Yaskawa representative if there is any trouble with the LED or keypad.</li> <li>Clean the LED.</li> </ul>  |         |

**Note:** Periodic inspections should be performed every one or two years. The drive, however, may require more frequent inspection due to poor environments or rigorous use.

## 7.3 Periodic Maintenance

The drive has various "maintenance monitors." This feature provides advance maintenance warning and eliminates the need to shut down the entire system for unexpected problems. The drive allows the user to check the following maintenance periods.

- Cooling Fan
- Electrolytic Capacitors (Main Circuit)
- Inrush Prevention Circuit
- IGBT

### ◆ Replacement Parts

**Table 7.2** contains the estimated performance life of components that require replacement during the life of the drive. Only use Yaskawa replacement parts for the appropriate drive model and revision.

**Table 7.2 Estimated Performance Life**

| Component                              | Estimated Performance Life |
|--|----------------------------|
| Cooling Fan                            | 10 years                   |
| Electrolytic Capacitors (Main Circuit) | 10 years <1>               |

<1> The drive has few serviceable parts and may require complete drive replacement.

**NOTICE:** *Estimated performance life based on specific usage conditions. These conditions are provided for the purpose of replacing parts to maintain performance. Some parts may require more frequent replacement due to poor environments or rigorous use.*

*Usage conditions for estimated performance life:*

- Ambient temperature: Yearly average of 40 °C
- Load factor: 80% maximum
- Operation time: 24 hours a day

### ■ Performance Life Monitors

The drive calculates the maintenance period for components that may require replacement during the life of the drive. A percentage of the maintenance period is displayed on the LED digital operator by viewing the appropriate monitor parameter.

When the maintenance period reaches 100%, there is increased risk that the drive may malfunction. Yaskawa recommends checking the maintenance period regularly to ensure maximum performance life.

**Table 7.3 Performance Life Monitors Used for Component Replacement**

| Parameter | Component                                     | Contents   |
|-----------|---|--|
| U4-03     | Cooling Fan                                   | Displays the accumulated operation time of the cooling fan, from 0 to 99999 hours. This value is automatically reset to 0 once it reaches 99999. |
| U4-04     |   | Displays the accumulated cooling fan operation time as a percentage of the specified maintenance period (displayed in percent %).                |
| U4-05     | Main Circuit (DC bus) Electrolytic Capacitors | Displays the accumulated time the capacitors are used as a percentage of the specified maintenance period.                                       |
| U4-06     | Inrush (pre-charge) relay                     | Displays the number of times the drive is powered up as a percentage of the performance life of the inrush circuit.                              |
| U4-07     | IGBT  | Displays the percentage of the maintenance period reached by the IGBTs.  |

## ■ Alarm Outputs for Maintenance Monitors

An output can be set up to inform the user when a specific components has neared its expected performance life.

When one of multi-function digital output terminals has been assigned the maintenance monitor function (H2-□□ = 2F), the terminal will close when the cooling fan, DC bus capacitors, or DC bus pre-charge relay reach 90% of the expected performance life, or when the IGBTs have reached 50% of their expected performance life. Additionally the digital operator will display an alarm like shown in [Table 7.4](#) to indicate the specific components that may need maintenance.

**Table 7.4 Maintenance Alarms**

| Digital Operator Alarm Display | Function | Corrective Action  |   |
|--------------------------------|----------|--|---|
| LF-1 <>                        | LT-1     | The cooling fans have reached 90% of their designated life time.       | Replace the cooling fan.  |
| LF-2 <>                        | LT-2     | The DC bus capacitors have reached 90% of their designated life time.  | Contact a Yaskawa representative or the nearest Yaskawa sales office on possible drive replacement. |
| LF-3 <>                        | LT-3     | The DC bus charge circuit has reached 90% of its designated life time. | Contact a Yaskawa representative or the nearest Yaskawa sales office on possible drive replacement. |
| LF-4 <>                        | LT-4     | The IGBTs have reached 50% of their designated life time.              | Check the load, carrier frequency, and output frequency.  |
| TrPC <>                        | TrPC     | The IGBTs have reached 90% of their designated life time.              | Contact a Yaskawa representative or the nearest Yaskawa sales office on possible drive replacement. |

- <1> This alarm message will be output only if the Maintenance Monitor function is assigned to one of the digital outputs (H2-□□ = 2F). The alarm will also trigger a digital output that is programmed for alarm indication (H2-□□ = 10).
- <2> This alarm message will always be output, even if the Maintenance Monitor function is not assigned to any of the digital outputs (H2-□□ = 2F). The alarm will also trigger a digital output that is programmed for alarm indication (H2-□□ = 10).

## ■ Related Drive Parameters

Use parameters o4-03, o4-05, o4-07, and o4-09 to reset a Maintenance Monitor to zero after replacing a specific component. [Refer to Parameter List on page 317](#) for details on parameter settings.

**NOTICE:** *If these parameters are not reset after the corresponding parts have been replaced, the Maintenance Monitor function will continue to count down the performance life from the value that was reached with the old part. If the Maintenance Monitor is not reset, the drive will not have the correct value of the performance life for the new component.*

### 7.4 Drive Cooling Fans

**NOTICE:** Follow cooling fan replacement instructions. The cooling fan cannot operate properly when installed incorrectly and could seriously damage the drive. To ensure maximum useful product life, replace all cooling fans when performing maintenance.

Contact your Yaskawa representative or supplier to order replacement cooling fans as required.

Some drive models have multiple cooling fans.

For drives with multiple cooling fans, replace all the fans when performing maintenance to ensure maximum useful product life.

#### ◆ Number of IP20/NEMA 1, UL Type 1 Cooling Fans

| Drive Model                     | Cooling Fans |
|---------------------------------|--------------|
| <b>Single-Phase 200 V Class</b> |              |
| BV0006F                         | –            |
| BV0010F                         | 1            |
| BV0012F                         | 1            |
| BV0018F                         | 2            |
| <b>Three-Phase 200 V Class</b>  |              |
| 2V0006F                         | 1            |
| 2V0010F                         | 1            |
| 2V0012F                         | 1            |
| 2V0020F                         | 1            |
| 2V0030F                         | 2            |
| 2V0040F                         | 2            |
| 2V0056F                         | 2            |
| 2V0069F                         | 2            |
| <b>Three-Phase 400 V Class</b>  |              |
| 4V0002F                         | –            |
| 4V0004F                         | –            |
| 4V0005F                         | 1            |
| 4V0007F                         | 1            |
| 4V0009F                         | 1            |
| 4V0011F                         | 1            |
| 4V0018F                         | 2            |
| 4V0023F                         | 2            |
| 4V0031F                         | 2            |
| 4V0038F                         | 2            |

## ◆ IP20/NEMA 1, UL Type 1 Cooling Fan Replacement

The cooling fan is installed on the top of the drive. The cooling fan can easily be replaced without tools or removal of the drive or enclosure parts.

**WARNING!** *Electrical Shock Hazard. Do not connect or disconnect wiring while the power is on. Failure to comply can result in serious personal injury. Before servicing the drive, disconnect all power to the equipment. The internal capacitor remains charged even after the power supply is turned off. The charge indicator LED will extinguish when the DC bus voltage is below 50 Vdc. To prevent electric shock, wait at least five minutes after all indicators are OFF and measure the DC bus voltage level to confirm safe level.*

**CAUTION!** *Burn Hazard. Do not touch a hot drive heatsink. Failure to comply could result in minor or moderate injury. Shut off the power to the drive when replacing the cooling fan. To prevent burns, wait at least 15 minutes and ensure the heatsink has cooled down.*

## ◆ Cooling Fan Replacement

The cooling fan is installed on the top of the drive. The cooling fan can easily be replaced without tools or removal of the drive or enclosure parts.

**WARNING!** *Electrical Shock Hazard. Do not connect or disconnect wiring while the power is on. Failure to comply can result in serious personal injury. Before servicing the drive, disconnect all power to the equipment. The internal capacitor remains charged even after the power supply is turned off. The charge indicator LED will extinguish when the DC bus voltage is below 50 Vdc. To prevent electric shock, wait at least five minutes after all indicators are OFF and measure the DC bus voltage level to confirm safe level.*

**CAUTION!** *Burn Hazard. Do not touch a hot drive heatsink. Failure to comply could result in minor or moderate injury. Shut off the power to the drive when replacing the cooling fan. To prevent burns, wait at least 15 minutes and ensure the heatsink has cooled down.*

## ■ Removing the Cooling Fan

1. Depress the right and left sides of the fan cover tabs and pull upward. Remove the fan cover from the top of the drive. The following figure illustrates a drive with a single cooling fan.

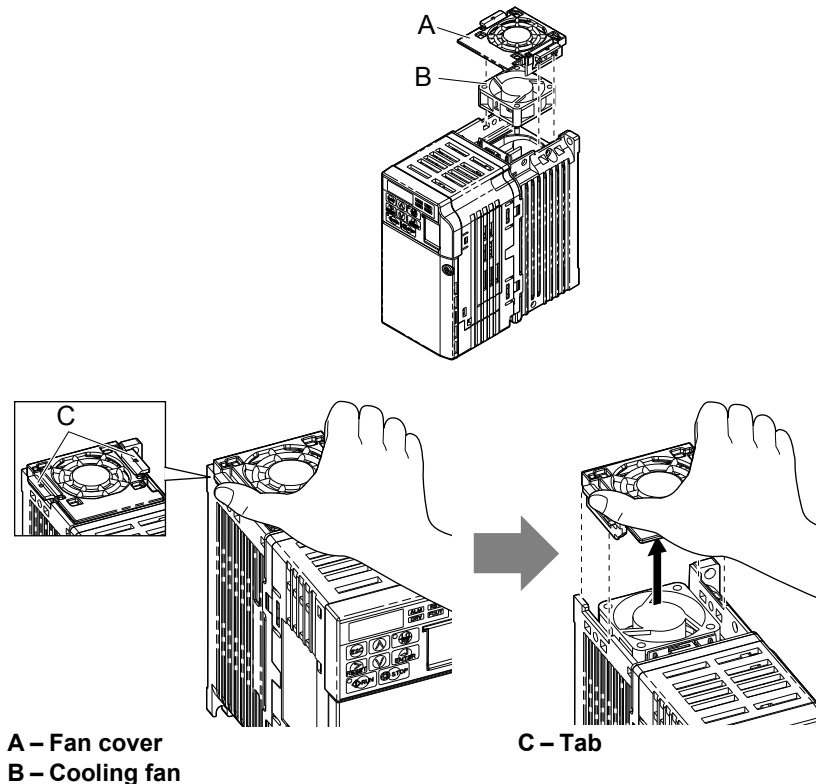


Figure 7.1 Remove the Cooling Fan Cover

2. Remove the fan cable carefully, disconnect the pluggable connector and remove the fan.

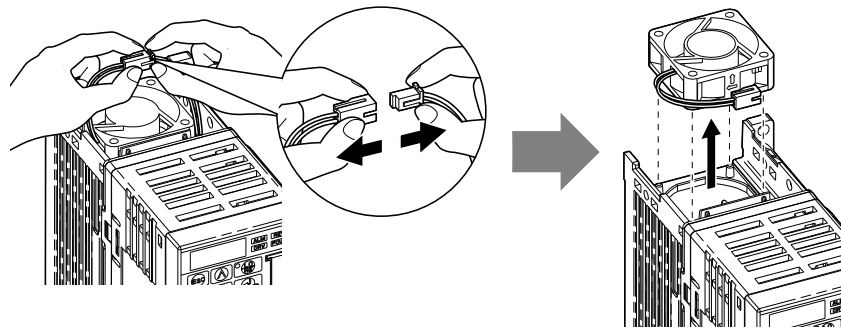
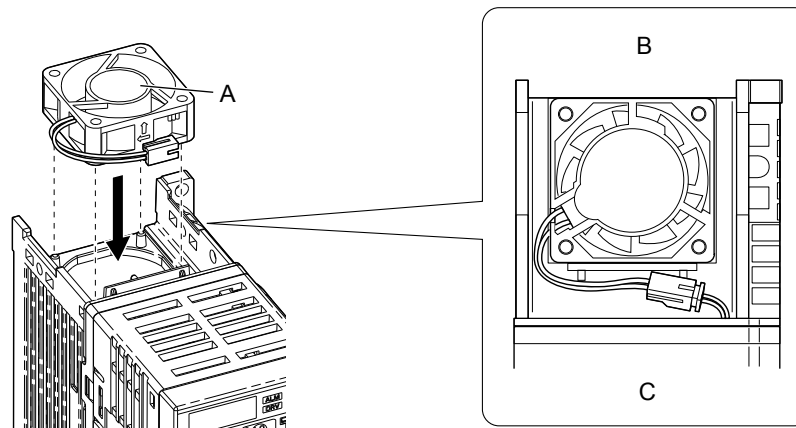


Figure 7.2 Disconnect and Remove the Fan

### ■ Installing the Cooling Fan

**NOTICE:** Prevent Equipment Damage. Follow cooling fan replacement instructions. Improper cooling fan replacement could result in damage to equipment. When installing the replacement cooling fan into the drive, make sure the fan is facing upwards. To ensure maximum useful product life, replace all cooling fans when performing maintenance.

1. Install the replacement cooling fan into the drive, ensuring the alignment pins line up, as shown in the figure below:

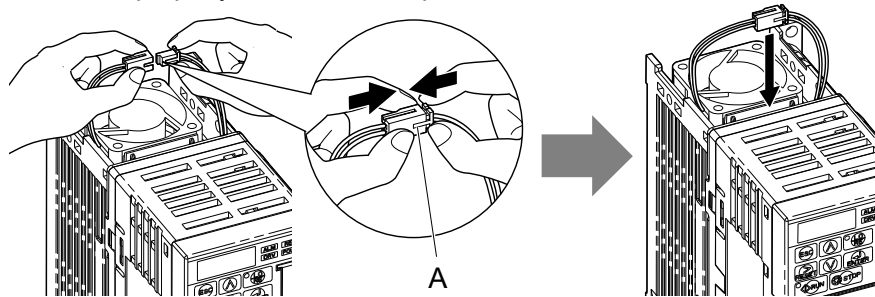


A – Label facing up  
B – Back

C – Front

Figure 7.3 Cooling Fan Orientation

2. Ensure the connectors are properly connected and place the cable back into the recess of the drive.



A – Push the connectors together so no space remains between them.

Figure 7.4 Connectors

**Note:** Ensure that the left and right tabs are locked back into place.

3. Align the left and right cover tabs to install the fan cover back on the top of the drive.



## ◆ Number of IP66/NEMA 4X, UL Type 4X Cooling Fans

| Drive Model                     | Number of Fans |              |
|---------------------------------|----------------|--------------|
|                                 | Internal Fan   | External Fan |
| <b>Single-Phase 200 V Class</b> |                |              |
| BV0006G                         | –              | –            |
| BV0010G                         | –              | –            |
| BV0012G                         | 1              | –            |
| <b>Three-Phase 200 V Class</b>  |                |              |
| 2V0006G                         | –              | –            |
| 2V0010G                         | –              | –            |
| 2V0012G                         | –              | –            |
| 2V0020G                         | 1              | –            |
| 2V0030G                         | 1              | 1            |
| 2V0040G                         | 1              | 1            |
| 2V0056G                         | 1              | 1            |
| 2V0069G                         | 1              | 2            |
| <b>Three-Phase 400 V Class</b>  |                |              |
| 4V0002G                         | –              | –            |
| 4V0004G                         | –              | –            |
| 4V0005G                         | –              | –            |
| 4V0007G                         | 1              | –            |
| 4V0009G                         | 1              | –            |
| 4V0011G                         | 1              | –            |
| 4V0018G                         | 1              | 1            |
| 4V0023G                         | 1              | 1            |
| 4V0031G                         | 1              | 1            |
| 4V0038G                         | 1              | 2            |

## ◆ IP66/NEMA 4X, UL Type 4X Cooling Fan Replacement

**WARNING! Electrical Shock Hazard.** Do not connect or disconnect wiring while the power is on. Failure to comply can result in serious personal injury. Before servicing the drive, disconnect all power to the equipment. The internal capacitor remains charged even after the power supply is turned off. The charge indicator LED will extinguish when the DC bus voltage is below 50 Vdc. To prevent electric shock, wait at least five minutes after all indicators are OFF and measure the DC bus voltage level to confirm safe level.

**CAUTION! Burn Hazard.** Do not touch a hot drive heatsink. Failure to comply could result in minor or moderate injury. Shut off the power to the drive when replacing the cooling fan. To prevent burns, wait at least 15 minutes and ensure the heatsink has cooled down.

## ■ Required Additional Parts

Table 7.5 Additional Parts

| Parts Sold Separately | Description   |
|-----------------------|---|
| Cooling Fan           | Contact your Yaskawa representative or the nearest Yaskawa sales office to order replacement cooling fans as required.  |
| RTV Sealant           | <b>Manufacturer:</b> Shin-Etsu PN: KE3494<br><b>Description:</b> Non-Flow, Electronic Grade RTV<br><b>North America:</b> Shin-Etsu Silicones of America, Inc.<br>1150 Damar Street, Akron, Ohio 44305-1201<br>Phone: 800-544-1745, Fax: 330-630-9855, <a href="http://www.shinetsua.com/">http://www.shinetsua.com/</a> |

## 7.4 Drive Cooling Fans

### Required Tools

Table 7.6 Tool Requirements

| Tool                                | Single-Phase<br>200 V Class   | Three-Phase<br>200 V Class               | Three-Phase<br>400 V Class                                     |
|-------------------------------------|-------------------------------|--|--|
| 8 mm socket wrench (cover removal)  | BV0006G<br>BV0010G<br>BV0012G | 2V0006G<br>2V0010G<br>2V0012G<br>2V0020G | 4V0002G<br>4V0004G<br>4V0005G<br>4V0007G<br>4V0009G<br>4V0011G |
| 10 mm socket wrench (cover removal) | —                             | 2V0030G<br>2V0040G<br>2V0056G<br>2V0069G | 4V0018G<br>4V0023G<br>4V0031G<br>4V0038G                       |
| 7 mm socket wrench (fan removal)    |                               | All models                               |  |

Refer to [Figure 7.5](#) for internal fan and external fan locations.

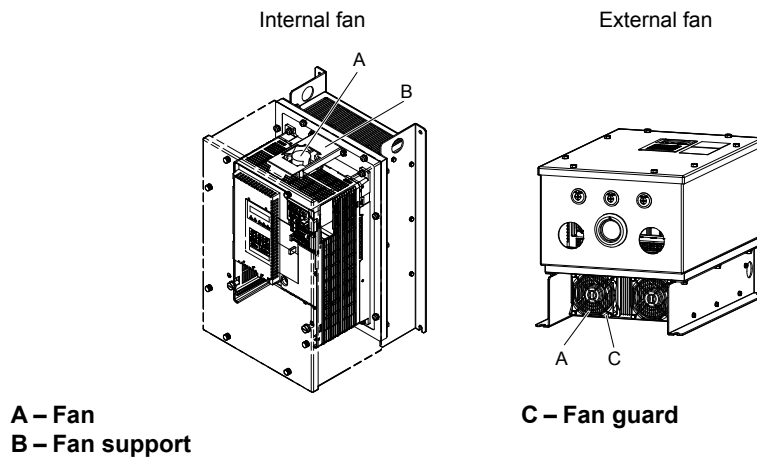


Figure 7.5 Cooling Fan Location in Model 2V0069G

### Removing the Internal Fan

1. Remove the front cover. [Refer to IP66/NEMA 4X, UL Type 4X Enclosure Front Cover Removal and Installation on page 48](#) for details.
2. Unplug the fan connector (CN7).

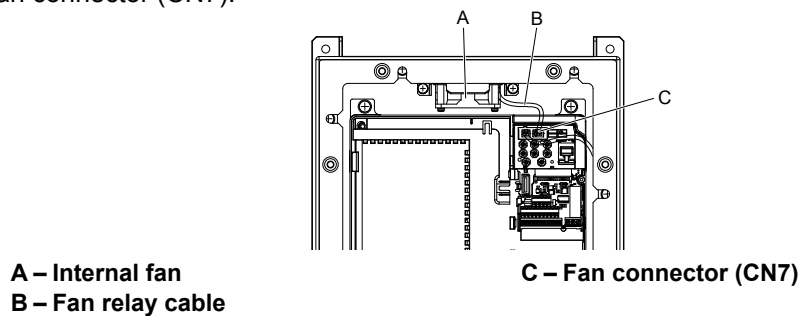


Figure 7.6 Internal Fan Components

3. Loosen the screws holding the fan unit in place then remove the fan unit from the drive.

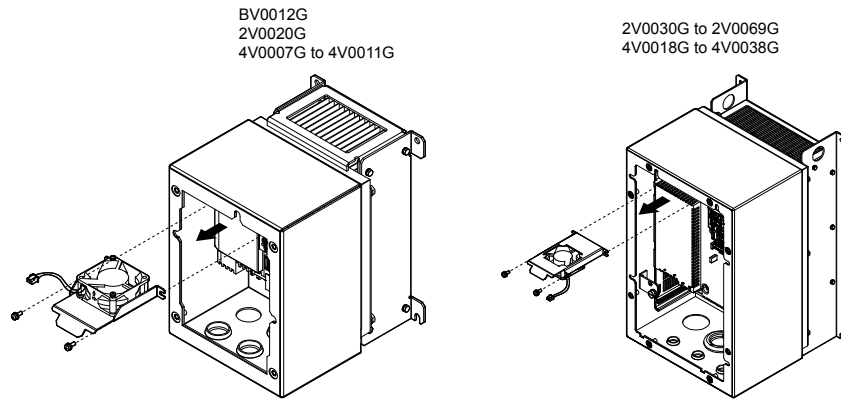


Figure 7.7 Removing the Internal Fan

■ Installing the Internal Fan

1. Fasten the replacement internal fan into place.

**Note:** Pay special attention to the fan label direction, fan lead wire routing, and fan support bracket direction when connecting the fan and the fan support in the drive.

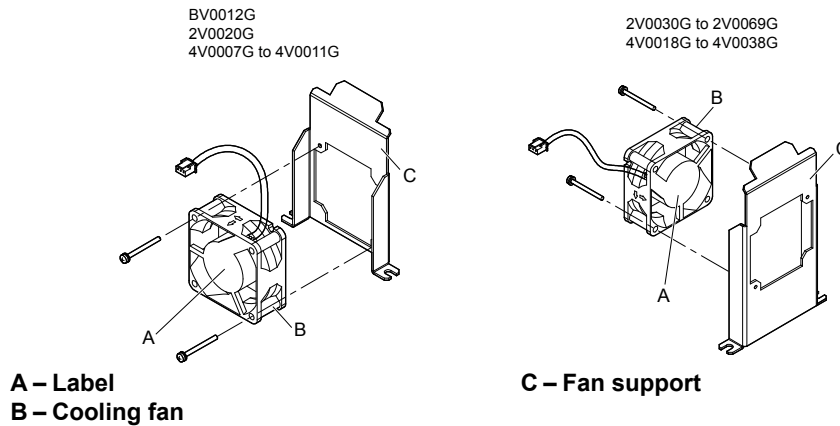


Figure 7.8 Internal Fan Replacement

2. Install the fan unit back into the drive enclosure in its original position.
3. Plug the fan connector (CN7) back in.

■ Removing the External Fan

1. Remove the front cover. [Refer to IP66/NEMA 4X, UL Type 4X Enclosure Front Cover Removal and Installation on page 48](#) for details.
2. Unplug the fan connector (CN7).

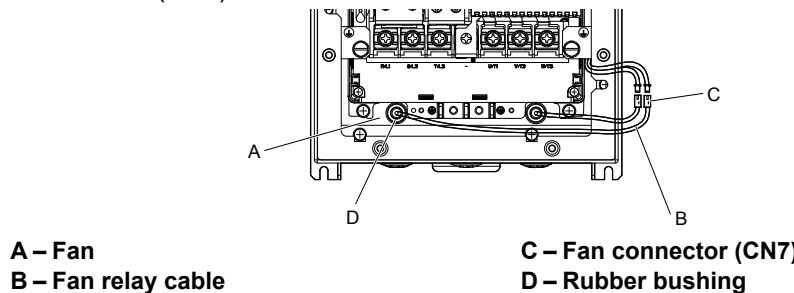


Figure 7.9 External Fan Components

**Note:** The external fan is installed outside of the waterproof/dust-proof enclosure.

3. Remove the screws to take the fan guard out of the drive. Push the rubber bushing out of conduit hole and take the internal fan out of the drive.

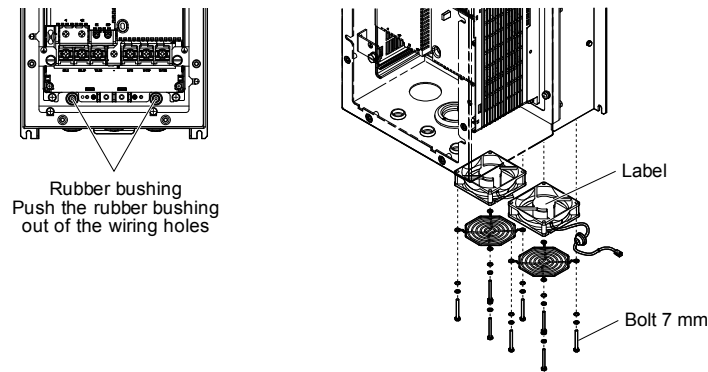


Figure 7.10 Removing the External Fan

### ■ Installing the External Fan

The external fan installation procedure differs by drive model. Refer to [Figure 7.11](#) for the different fan configurations.

**NOTICE:** Install the fan with the label facing the toward the inside of the drive. The fan may be damaged if it is facing the wrong direction.

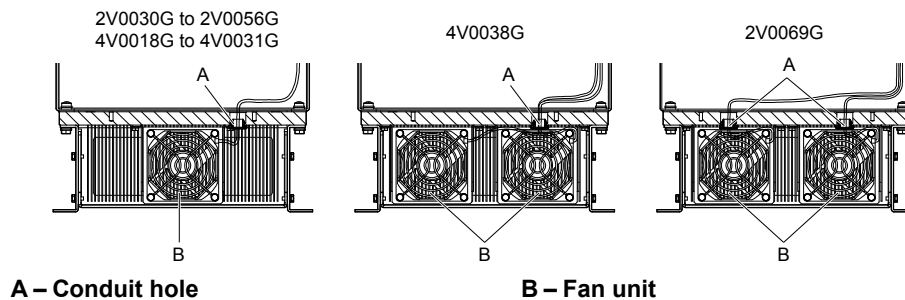


Figure 7.11 External Fans and Conduit Holes

1. Place the rubber bushing for the fan into the heatsink holes.

**NOTICE:** Ensure that all bushings fit securely into place. Loose rubber bushings may allow water and dust to enter the drive.

2. Route the fan wiring through the rubber bushing.
3. Plug the fan connector back in.
4. Fill the wiring hole in the rubber grommet to a minimum depth of 9.7 mm (0.38 in.) with RTV sealant (KE-3494) specified in [Table 7.5](#).

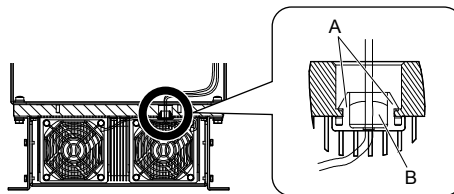


Figure 7.12 Fastening the Rubber Bushing in Model 4V0038G

5. Install the fan guard onto the fan.
6. Replace the fan into its original position and fasten the fan into place.

## 7.5 Drive Replacement

### ◆ Serviceable Parts

The drive contains few serviceable parts. The following parts are considered replacement parts on the drive:

- Main control board and I/O Terminal board I/O PCBs.
- Cooling fan(s)
- Front cover

Replace the drive if the main power circuitry is damaged. Contact your local Yaskawa representative before replacing parts if the drive is still under warranty. Yaskawa reserves the right to replace or repair the drive according to Yaskawa warranty policy.

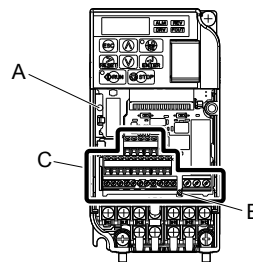
On IP66/NEMA 4X, UL Type 4X enclosure drives, replace the entire unit (drive, enclosure, and heatsink) in the event that any single part becomes damaged. The drive, waterproof/dustproof enclosure, and heatsink are constructed as a single piece, and it is not possible to replace the drive separately from the protective enclosure.

**WARNING! Electrical Shock Hazard.** Do not connect or disconnect wiring while the power is on. Failure to comply can result in serious personal injury. Before servicing the drive, disconnect all power to the equipment. The internal capacitor remains charged even after the power supply is turned off. The charge indicator LED will extinguish when the DC bus voltage is below 50 Vdc. To prevent electric shock, wait at least five minutes after all indicators are OFF and measure the DC bus voltage level to confirm safe level.

### ◆ Terminal Board Overview

The drive has a modular I/O terminal block that facilitates quick drive replacement. The terminal board contains on-board memory that stores all drive parameter settings and allows the parameters to be saved and transferred to the replacement drive by disconnecting the terminal board from the damaged drive then reconnecting the terminal board to the replacement drive. There is no need to manually reprogram the replacement drive.

**Note:** When transferring the removable terminal block with backup memory to a drive with a different voltage class or different output capacity, set A1-03 to 2220 to initialize the drive after installing the terminal block.



A – Charge LED

B – Terminal Board Locking Pin

C – Removable Terminal Board

Figure 7.13 Terminal Board

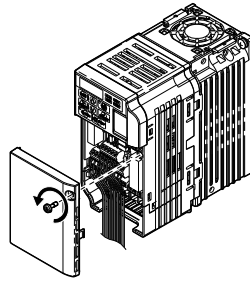
### ◆ Dismantling the Removable Terminal Block

**WARNING! Electrical Shock Hazard.** Never connect or disconnect wiring, remove connectors or option cards, or replace the cooling fan while the power is on. Failure to comply may result in serious injury. Before servicing, disconnect all power to the equipment. The internal capacitor remains charged even after the power supply is turned off.

**WARNING! Electrical Shock Hazard.** Do not allow unqualified personnel to perform work on the drive. Failure to comply could result in serious injury. Installation, maintenance, inspection and servicing must be performed only by authorized personnel familiar with installation, adjustment and maintenance of AC drives.

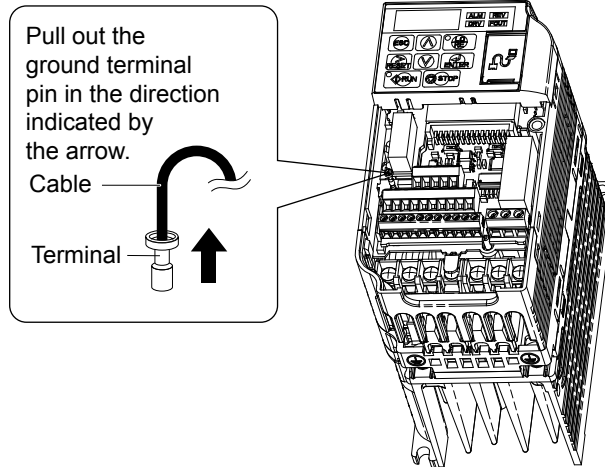
**NOTICE: Damage to Equipment.** Observe proper electrostatic discharge procedures (ESD) when handling the drive and circuit boards. Failure to comply may result in ESD damage to the drive circuitry.

1. Loosen the screw on the front of the drive and remove the front cover.



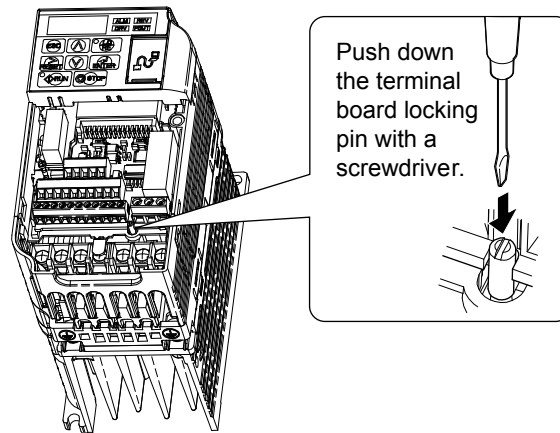
**Figure 7.14 Remove the Front Cover**

2. Pull the pin on the ground terminal out of the removable terminal block.



**Figure 7.15 Pull Out the Ground Terminal**

3. Push down the installation pin on the terminal board with a screwdriver



**Figure 7.16 Depress the Plastic Tab**

4. While holding down the locking pin from step 3, slide the removable terminal block in the direction of the arrows in [Figure 7.17](#).

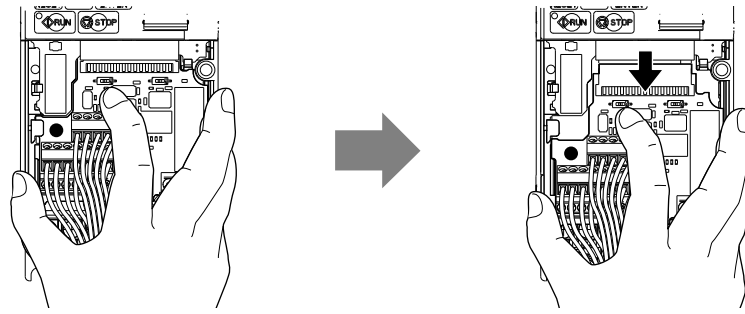


Figure 7.17 Remove the Terminal Board

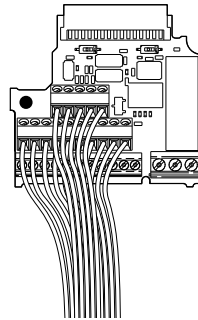


Figure 7.18 Removable Terminal Board Disconnected from the Drive

### ■ Reinstalling the Terminal Board

1. Reinstall the removable terminal block on the drive according to [Figure 7.19](#).

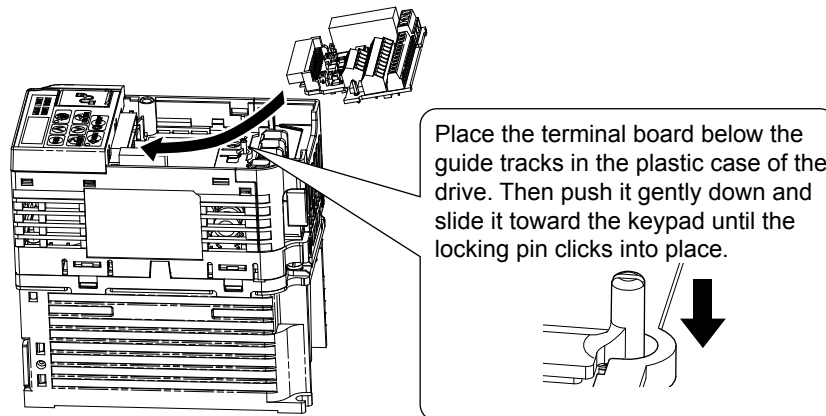


Figure 7.19 Terminal Board Reinstallation

2. Ensure the terminal block is firmly fastened to the connector.

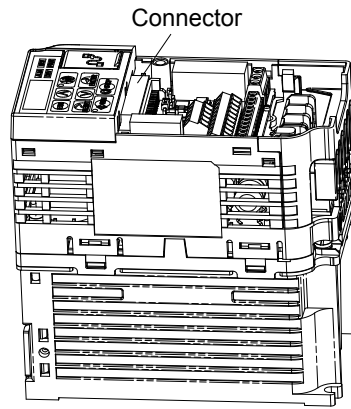


Figure 7.20 Terminal Board Reinstalled

3. Put the lower cover and the terminal cover back in place.
4. After replacing the drive, check the drive unit selection setting in o2-04. [Refer to Defaults by Drive Model on page 377](#) for more information.
5. An oPE04 error may occur when replacing the drive or the removable terminal block. If the data saved to the terminal block is compatible, set A1-03 to 5550 to write the parameter settings stored in the terminal block to the new drive. Reset the appropriate maintenance monitors using parameters o4-01 to o4-13.

---

### ◆ Details on Terminal Board (TB) or Control Board (CNT) Replacement

The drive Terminal Board retains drive parameter settings to significantly improve the ease of drive replacement. [Refer to Troubleshooting Terminal Board or Control Board Replacement on page 305](#) for a flowchart to assist in board replacement. When replacing the drive, or changing the Control Board or Terminal Board, the following error codes may be encountered upon application of power:

- oPE04 Drive parameter settings need to be initialized or uploaded from the TB.
- CPF06 Drive specification does not match the replaced drive.
- oPE01 Drive parameter o2-04 kVA requires setting.

#### Procedural Notes:

1. When replacing the drive, control board or terminal board, make sure to confirm the kVA setting, parameter o2-04 is correct upon initial power-up.
2. Perform an initialization (via parameter A1-03) to obtain the desired parameter settings.
3. In cases where a previously programmed terminal board is retained, initializing the drive with a setting of A1-03 = 5550 may be desired to program the drive with previously programmed settings (settings used prior to replacing the drive or control board).



Troubleshooting Fault Codes at  
Terminal Board (TB) or Control Board (CNT) Replacement

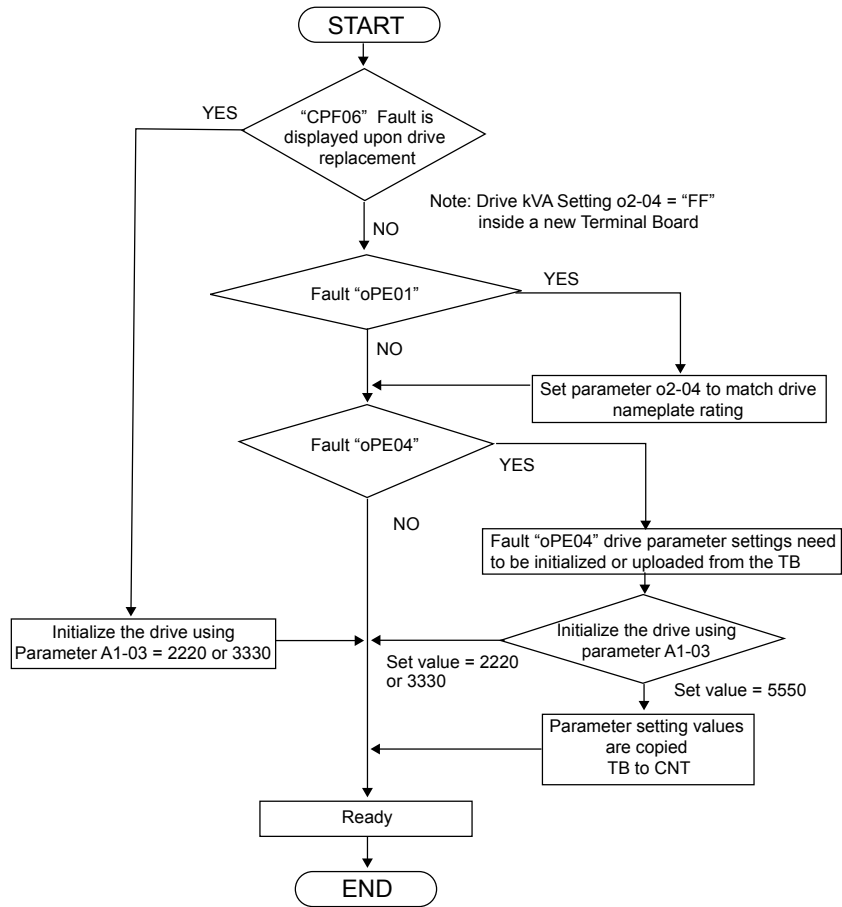


Figure 7.21 Troubleshooting Terminal Board or Control Board Replacement

**This Page Intentionally Blank**

# Appendix: A

## Specifications

---

|            |                                  |            |
|------------|----------------------------------|------------|
| <b>A.1</b> | <b>POWER RATINGS.....</b>        | <b>308</b> |
| <b>A.2</b> | <b>DRIVE SPECIFICATIONS.....</b> | <b>311</b> |
| <b>A.3</b> | <b>DRIVE WATT LOSS DATA.....</b> | <b>313</b> |
| <b>A.4</b> | <b>DRIVE DERATING DATA.....</b>  | <b>314</b> |

## A.1 Power Ratings

### ◆ Single-Phase 200 V Class Drives

Table A.1 Single-Phase 200 V Class Power Ratings

| Item                                   |                                  | Specification   |         |         |         |
|--|----------------------------------|---|---------|---------|---------|
| Single-Phase Drive Model <1>           |                                  | BV0006  | BV0010  | BV0012  | BV0018  |
| Maximum Motor Size Allowed kW (HP) <2> |                                  | 1.1 (1)   | 2.2 (3) | 3.0 (3) | 3.7 (5) |
| Input                                  | Input Current (A) <3>            | 13.8  | 20.2    | 24.0    | 35.0    |
| Output                                 | Rated Output Capacity (kVA) <4>  | 2.3   | 3.7     | 4.6     | 6.7     |
|  | Output Current (A)               | 6.0   | 9.6     | 12.0    | 17.5    |
|  | Overload Tolerance               | 120% of rated output current for 1 minute<br>(Derating may be required for applications that start and stop frequently) |         |         |         |
|  | Carrier Frequency                | User-adjustable 2 to 15 kHz   |         |         |         |
|  | Max Output Voltage (V)           | Single-phase power: 200 to 240 V<br>(both proportional to input voltage)  |         |         |         |
|  | Max Output Frequency (Hz)        | 400 Hz (user-adjustable)  |         |         |         |
| Power Supply                           | Rated Voltage<br>Rated Frequency | Single-phase power: 200 to 240 V 50/60 Hz<br>DC power supply: 270 to 340 V <5>  |         |         |         |
|  | Allowable Voltage Fluctuation    | -15 to 10%  |         |         |         |
|  | Allowable Frequency Fluctuation  | ±5%   |         |         |         |
| Harmonic Corrective Actions            | DC Link Choke                    | Optional  |         |         |         |

<1> Drives with single-phase power supply input will output three-phase power and cannot run a single-phase motor.

<2> The motor capacity (HP) refers to a NEC rated 4-pole motor. The rated output current of the drive output amps should be equal to or greater than the motor rated current.

<3> Input current rating varies depending on the power supply transformer, input reactor, wiring connections, and power supply impedance.

<4> Rated motor capacity is calculated with a rated output voltage of 230 V.

<5> DC is not available for UL standards.

## ◆ Three-Phase 200 V Class Drives

Table A.2 Three-Phase 200 V Class Power Ratings

| Item                                   |                                  | Specification   |         |         |         |
|--|----------------------------------|---|---------|---------|---------|
| Three-Phase Drive Model                |                                  | 2V0006  | 2V0010  | 2V0012  | 2V0020  |
| Maximum Motor Size Allowed kW (HP) <1> |                                  | 1.1 (1.5)   | 2.2 (3) | 3.0 (3) | 5.5 (5) |
| Input                                  | Input Current (A) <2>            | 7.3   | 10.8    | 13.9    | 24.0    |
| Output                                 | Rated Output Capacity (kVA) <3>  | 2.3   | 3.7     | 4.6     | 7.5     |
|  | Output Current (A)               | 6.0   | 9.6     | 12.0    | 19.6    |
|  | Overload Tolerance               | 120% of rated output current for 1 minute<br>(Derating may be required for applications that start and stop frequently) |         |         |         |
|  | Carrier Frequency                | User-adjustable 2 to 15 kHz   |         |         |         |
|  | Max Output Voltage (V)           | Three-phase power: 200 to 240 V<br>(proportional to input voltage)  |         |         |         |
|  | Max Output Frequency (Hz)        | 400 Hz (user-adjustable)  |         |         |         |
| Power Supply                           | Rated Voltage<br>Rated Frequency | Three-phase power: 200 to 240 V 50/60 Hz<br>DC power supply: 270 to 340 V <4>   |         |         |         |
|  | Allowable Voltage Fluctuation    | -15 to 10%  |         |         |         |
|  | Allowable Frequency Fluctuation  | ±5%   |         |         |         |
| Harmonic Corrective Actions            | DC Link Choke                    | Optional  |         |         |         |

<1> The motor capacity (HP) refers to a NEC rated 4-pole motor. The rated output current of the drive output amps should be equal to or greater than the motor rated current.

<2> Input current rating varies depending on the power supply transformer, input reactor, wiring connections, and power supply impedance.

<3> Rated motor capacity is calculated with a rated output voltage of 230 V.

<4> DC is not available for UL standards.

Table A.3 Three-Phase 200 V Class Power Ratings Continued

| Item                                   |                                  | Specification   |         |         |           |
|--|----------------------------------|---|---------|---------|-----------|
| Three-Phase Model                      |                                  | 2V0030  | 2V0040  | 2V0056  | 2V0069    |
| Maximum Motor Size Allowed kW (HP) <1> |                                  | 7.5 (10)  | 11 (10) | 15 (20) | 18.5 (25) |
| Input                                  | Input Current (A) <2>            | 37.0  | 52.0    | 68.0    | 80.0      |
| Output                                 | Rated Output Capacity (kVA) <3>  | 11.4  | 15.2    | 21.3    | 26.3      |
|  | Output Current (A)               | 30.0  | 40.0    | 56.0    | 69.0      |
|  | Overload Tolerance               | 120% of rated output current for 1 minute<br>(Derating may be required for applications that start and stop frequently) |         |         |           |
|  | Carrier Frequency                | User-adjustable 2 to 15 kHz   |         |         |           |
|  | Max Output Voltage (V)           | Three-phase power: 200 to 240 V<br>(proportional to input voltage)  |         |         |           |
|  | Max Output Frequency (Hz)        | 400 Hz (user-adjustable)  |         |         |           |
| Power Supply                           | Rated Voltage<br>Rated Frequency | Three-phase power: 200 to 240 V 50/60 Hz<br>DC power supply: 270 to 340 V <4>   |         |         |           |
|  | Allowable Voltage Fluctuation    | -15 to 10%  |         |         |           |
|  | Allowable Frequency Fluctuation  | ±5%   |         |         |           |
| Harmonic Corrective Actions            | DC Link Choke                    | Optional  |         |         |           |

<1> The motor capacity (HP) refers to a NEC rated 4-pole motor. The rated output current of the drive output amps should be equal to or greater than the motor rated current.

<2> Input current rating varies depending on the power supply transformer, input reactor, wiring connections, and power supply impedance.

<3> Rated motor capacity is calculated with a rated output voltage of 230 V.

<4> DC is not available for UL standards.

### ◆ Three-Phase 400 V Class Drives

Table A.4 Three-Phase 400 V Class Power Ratings

| Item  |                                  | Specification   |         |         |         |         |
|---|----------------------------------|---|---------|---------|---------|---------|
| Three-Phase Model                             |                                  | 4V0002  | 4V0004  | 4V0005  | 4V0007  | 4V0009  |
| Maximum Applicable Motor Capacity kW (HP) <1> |                                  | 0.75 (1.0)  | 1.5 (2) | 2.2 (3) | 3.0 (3) | 3.7 (5) |
| Input   | Input Current (A) <2>            | 2.1   | 4.3     | 5.9     | 8.1     | 9.4     |
| Output  | Rated Output Capacity (kVA) <3>  | 1.6   | 3.1     | 4.1     | 5.3     | 6.7     |
|   | Output Current (A)               | 2.1   | 4.1     | 5.4     | 6.9     | 8.8     |
|   | Overload Tolerance               | 120% of rated output current for 60 s<br>(Derating may be required for applications that start and stop frequently) |         |         |         |         |
|   | Carrier Frequency                | User-adjustable 2 to 15 kHz   |         |         |         |         |
|   | Max Output Voltage (V)           | Three-phase power: 380 to 480 V (proportional to input voltage)   |         |         |         |         |
|   | Max Output Frequency (Hz)        | 400 Hz (user-adjustable)  |         |         |         |         |
| Power Supply                                  | Rated Voltage<br>Rated Frequency | Three-phase power: 380 to 480 V 50/60 Hz<br>DC power supply: 510 to 680 V <4>                                       |         |         |         |         |
|   | Allowable Voltage Fluctuation    | -15 to 10%  |         |         |         |         |
|   | Allowable Frequency Fluctuation  | ±5%   |         |         |         |         |
| Harmonic Corrective Actions                   | DC Link Choke                    | Optional  |         |         |         |         |

<1> The motor capacity (HP) refers to a NEC 4-pole motor. The rated output current of the drive output amps should be equal to or greater than the motor rated current.

<2> Input current rating varies depending on the power supply transformer, input reactor, wiring conditions, and power supply impedance.

<3> Rated motor capacity is calculated with a rated output voltage of 460 V.

<4> DC is not available for UL standards.

Table A.5 Three-Phase 400 V Class Power Ratings Continued

| Item  |                                  | Specification   |          |         |         |           |
|---|----------------------------------|---|----------|---------|---------|-----------|
| Three-Phase Model                             |                                  | 4V0011  | 4V0018   | 4V0023  | 4V0031  | 4V0038    |
| Maximum Applicable Motor Capacity kW (HP) <1> |                                  | 5.5 (7.5)   | 7.5 (10) | 11 (15) | 15 (20) | 18.5 (25) |
| Input   | Input Current (A) <2>            | 14.0  | 20.0     | 24.0    | 38.0    | 44.0      |
| Output  | Rated Output Capacity (kVA) <3>  | 8.5   | 13.3     | 17.5    | 23.6    | 29.0      |
|   | Output Current (A)               | 11.1  | 17.5     | 23.0    | 31.0    | 38.0      |
|   | Overload Tolerance               | 120% of rated output current for 60 s<br>(Derating may be required for applications that start and stop frequently) |          |         |         |           |
|   | Carrier Frequency                | User-adjustable 2 to 15 kHz   |          |         |         |           |
|   | Max Output Voltage (V)           | Three-phase power: 380 to 480 V (proportional to input voltage)   |          |         |         |           |
|   | Max Output Frequency (Hz)        | 400 Hz (user-adjustable)  |          |         |         |           |
| Power Supply                                  | Rated Voltage<br>Rated Frequency | Three-phase power: 380 to 480 V 50/60 Hz<br>DC power supply: 510 to 680 V <4>                                       |          |         |         |           |
|   | Allowable Voltage Fluctuation    | -15 to 10%  |          |         |         |           |
|   | Allowable Frequency Fluctuation  | ±5%   |          |         |         |           |
| Harmonic Corrective Actions                   | DC Link Choke                    | Optional  |          |         |         |           |

<1> The motor capacity (HP) refers to a NEC 4-pole motor. The rated output current of the drive output amps should be equal to or greater than the motor rated current.

<2> Input current rating varies depending on the power supply transformer, input reactor, wiring conditions, and power supply impedance.

<3> Rated motor capacity is calculated with a rated output voltage of 460 V.

<4> DC is not available for UL standards.

## A.2 Drive Specifications

**Note:** For optimum performance life of the drive, install the drive in an environment that meets the required specifications.

|                                | Item   | Specification  |
|--------------------------------|--|--|
| <b>Control Characteristics</b> | <b>Control Method</b>                          | V/f Control (V/f)  |
|                                | <b>Frequency Control Range</b>                 | 0.01 to 400 Hz   |
|                                | <b>Frequency Accuracy</b>                      | Digital input: within ±0.01% of the max output frequency (-10 to +50 °C)<br>Analog input: within ±0.5% of the max output frequency (25 °C ±10 °C)  |
|                                | <b>Frequency Setting Resolution</b>            | Digital inputs: 0.01 Hz<br>Analog inputs: 1/1000 of maximum output frequency   |
|                                | <b>Output Frequency Calculation Resolution</b> | 1/2 <sup>20</sup> x Maximum output frequency (E1-04)   |
|                                | <b>Frequency Setting Signal</b>                | Main frequency reference: 0 to +10 Vdc (20 kΩ), 4 to 20 mA (250 Ω), 0 to 20 mA (250 Ω)<br>Main speed reference: Pulse Train Input (max 32 kHz)   |
|                                | <b>Starting Torque</b>                         | V/f: 150% at 3 Hz  |
|                                | <b>Speed Control Range</b>                     | 1:40 (V/f Control)   |
|                                | <b>Accel/Decel Time</b>                        | 0.00 to 6000.0 s (allows four separate settings for accel and decel)   |
|                                | <b>Braking Torque</b>                          | Instantaneous Average Decel Torque <math>\langle \rangle</math>: 0.1/0.2 kW: over 150%, 0.4/0.75 kW: over 100%, 1.5 kW: over 50%, 2.2 kW and above: over 20%<br>Continuous Regen Torque: 20%, 125% with a Braking Resistor Unit <math>\langle \rangle</math>: (10% ED) 10 s with an internal braking resistor.   |
|                                | <b>V/f Characteristics</b>                     | Preset V/f patterns and user-set program available.  |
| <b>Protection Functions</b>    | <b>Functions</b>                               | Momentary Power Loss Ride-Thru<br>Speed Search<br>Over/Undertorque Detection<br>Multi-Step Speed (17 steps max)<br>Accel/Decel Time Switch<br>S-Curve Accel/Decel,<br>2-Wire/3-Wire Sequence<br>Stationary Auto-Tuning of Line-to-Line Resistance<br>Dwell<br>Cooling Fan ON/OFF<br>Slip Compensation<br>Torque Compensation<br>Jump Frequencies (reference dead band)<br>Frequency Reference Upper/Lower Limit<br>DC Injection Braking (start and stop)<br>PID Control (with Sleep Function)<br>MEMOBUS/Modbus (RS-485/RS-422 Max 115.2 kbps)<br>Fault Reset<br>Parameter Copy<br>Fault Restart<br>Removable Terminals with Parameter Backup Function |
|                                | <b>Motor Protection</b>                        | Motor overheat protection via output current sensor  |
|                                | <b>Overcurrent Protection</b>                  | Drives stops when output exceeds 170% of the rated current   |
|                                | <b>Overload Protection</b>                     | Drive stops when output current is 120% rated current for 60 sec. <math>\langle \rangle</math>   |
|                                | <b>Overvoltage Specification</b>               | 200 V Class: Stops when DC bus voltage exceeds approx. 410 V<br>400 V Class: Stops when DC bus voltage exceeds approx. 820 V   |
|                                | <b>Low Voltage Protection</b>                  | Drive stops when DC bus voltage falls below the levels indicated:<br>190 V (3-phase 200 V), 160 V (single-phase 200 V), 380 V (3-phase 400 V), 350 V (3-phase 380 V)   |
|                                | <b>Momentary Power Loss Ride-Thru</b>          | 3 selections available: Ride-Thru disabled (stops after 15 ms), time base of 0.5 s, and continue running as long as the drive control board is powered up. <math>\langle \rangle</math>  |

## A.2 Drive Specifications

| Item                 |                                      | Specification  |
|----------------------|--------------------------------------|--|
| Protection Functions | Heatsink Overheat Protection         | Protected by thermistor  |
|                      | Braking Resistor Overheat Protection | Overheat input signal for braking resistor (Optional ERF-type, 3% ED)  |
|                      | Stall Prevention                     | Stall prevention is available during acceleration, deceleration, and during run. Separate settings for each type of stall prevention determine the current level at which stall prevention is triggered.   |
|                      | Cooling Fan Failure Protection       | Circuit protection ("fan-lock" sensor)   |
|                      | Ground Fault Protection              | Electronic circuit protection <5>  |
|                      | DC Bus Charge LED                    | Remains lit until DC bus voltage falls below 50 V  |
| Environment          | Storage/Installation Area            | Indoors  |
|                      | Ambient Temperature                  | IP20/NEMA 1, UL Type 1 enclosure: -10 °C to +40 °C (14 °F to 104 °F)<br>IP66/NEMA 4X, UL Type 4X enclosure: -10 °C to +40 °C (14 °F to 104 °F)   |
|                      | Humidity                             | 95% RH or less with no condensation  |
|                      | Storage Temperature                  | -20 to +60 °C (-4 to +140 °F) allowed for short-term transport of the product  |
|                      | Altitude                             | Up to 1000 meters without derating; up to 3000 meters with output current and voltage derating.  |
|                      | Shock, Impact                        | 10 to 20 Hz: 9.8 m/s <sup>2</sup><br>20 to 55 Hz: 5.9 m/s <sup>2</sup>   |
|                      | Surrounding Area                     | Install the drive in an area free from: <ul style="list-style-type: none"> <li>oil mist and dust</li> <li>metal shavings, oil, water or other foreign materials</li> <li>radioactive materials</li> <li>combustible materials (e.g., wood)</li> <li>harmful gases and liquids</li> <li>excessive vibration</li> <li>chlorides</li> <li>direct sunlight</li> </ul> For IP66/NEMA 4X, UL Type 4X enclosure drives, install the drive in an environment suitable for IP66/NEMA 4X, UL Type 4X enclosures: <ul style="list-style-type: none"> <li>NEMA 4X, UL Type 4X – Enclosures constructed for either indoor or outdoor use to provide a degree of protection to personnel against incidental contact with the enclosed equipment; to provide a degree of protection against falling dirt, rain, sleet, snow, windblown dust, splashing water, hose-directed water, and corrosion; and that will be undamaged by the external formation of ice on the enclosure.</li> <li>IP66 – Dust-tight enclosures to not allow any dust to penetrate. The enclosure guards the drive against powerful jetting water sprayed from any direction and is protected against access to hazardous parts with a wire.</li> </ul> |
|                      | Orientation                          | Install the drive vertically to maintain maximum cooling effects   |
| Standards            |                                      | cULus  |
| Protective Enclosure |                                      | IP20/NEMA 1, UL Type 1<br>IP66/NEMA 4X, UL Type 4X   |
| Cooling Method       |                                      | BV0006F: self-cooled<br>BV0010F to BV0018F: cooling fan<br>2V0006F to 2V0069F: cooling fan<br>4V0002F to 4V0004F: self-cooled<br>4V0005F to 4V0038F: cooling fan<br>BV0006G and BV0010G: self-cooled<br>BV0012G: internal cooling fan<br>2V0006G to 2V0012G: self-cooled<br>2V0020G: internal cooling fan<br>2V0030G to 2V0069G: internal and external cooling fans<br>4V0002G to 4V0005G: self-cooled<br>4V0007G to 4V0011G: internal cooling fan<br>4V0018G to 4V0038G: internal and external cooling fans   |

- <1> Instantaneous average deceleration torque refers to the torque required to decelerate the motor (uncoupled from the load) from the rated motor speed down to zero in the shortest time.
- <2> Ensure that Stall Prevention Selection during Deceleration is disabled (L3-04 = 0) or set to 3 when using a braking resistor or the Braking Resistor Unit. The default setting for the stall prevention function will interfere with the braking resistor.
- <3> Overload protection may be triggered when operating with 150% of the rated output current if the output frequency is less than 6 Hz.
- <4> A Momentary Power Loss Ride-Thru Unit is required for 200/400 V class drives 7.5 kW and less if the application needs to continue running during a momentary power loss up to 2 seconds.
- <5> Ground protection cannot be provided under the following circumstances when a ground fault is likely in the motor windings during run: Low ground resistance for the motor cable and terminal block; low ground resistance for the motor cable and terminal block; or the drive is powered up from a ground short.



## A.3 Drive Watt Loss Data

Table A.6 Watt Loss 200 V Class Single-Phase Models

| Drive Model | Normal Duty (Swing PWM equal 2 kHz) |                   |                        |                |
|-------------|-------------------------------------|-------------------|------------------------|----------------|
|             | Rated Amps (A)                      | Heatsink Loss (W) | Interior Unit Loss (W) | Total Loss (W) |
| BV0006      | 6.0                                 | 30.1              | 19.4                   | 49.5           |
| BV0010      | 9.6                                 | 51.7              | 29.8                   | 81.4           |
| BV0012      | 12.0                                | 61.3              | 37.1                   | 98.4           |
| BV0018      | 17.5                                | 110.5             | 51.4                   | 161.9          |

Table A.7 Watt Loss 200 V Class Three-Phase Models

| Drive Model | Normal Duty (Swing PWM equal 2 kHz) |                   |                        |                |
|-------------|-------------------------------------|-------------------|------------------------|----------------|
|             | Rated Amps (A)                      | Heatsink Loss (W) | Interior Unit Loss (W) | Total Loss (W) |
| 2V0006      | 6.0                                 | 27.5              | 17.2                   | 44.7           |
| 2V0010      | 9.6                                 | 51.7              | 25.8                   | 77.5           |
| 2V0012      | 12.0                                | 61.3              | 30.4                   | 91.7           |
| 2V0020      | 19.6                                | 98.7              | 46.3                   | 145.0          |
| 2V0030      | 30.0                                | 246.4             | 88.9                   | 335.3          |
| 2V0040      | 40.0                                | 266.7             | 112.8                  | 379.6          |
| 2V0056      | 56.0                                | 357.9             | 151.8                  | 509.7          |
| 2V0069      | 69.0                                | 461.7             | 184.5                  | 646.2          |

Table A.8 Watt Loss 400 V Class Three-Phase Models

| Drive Model | Normal Duty (Swing PWM equal 2 kHz) |                   |                        |                |
|-------------|-------------------------------------|-------------------|------------------------|----------------|
|             | Rated Amps (A)                      | Heatsink Loss (W) | Interior Unit Loss (W) | Total Loss (W) |
| 4V0002      | 2.1                                 | 18.5              | 13.9                   | 32.4           |
| 4V0004      | 4.1                                 | 30.5              | 16.8                   | 47.3           |
| 4V0005      | 5.4                                 | 44.5              | 21.8                   | 66.3           |
| 4V0007      | 6.9                                 | 58.5              | 28.4                   | 86.9           |
| 4V0009      | 8.8                                 | 63.7              | 31.4                   | 95.1           |
| 4V0011      | 11.1                                | 81.7              | 46.0                   | 127.7          |
| 4V0018      | 17.5                                | 181.2             | 80.1                   | 261.3          |
| 4V0023      | 23.0                                | 213.4             | 107.7                  | 321.1          |
| 4V0031      | 31.0                                | 287.5             | 146.1                  | 433.6          |
| 4V0038      | 38.0                                | 319.2             | 155.8                  | 475.0          |

## A.4 Drive Derating Data

The drive can be operated at above the rated temperature, altitude, and default carrier frequency by derating the drive capacity.

### ◆ Single-Phase Derating

iQpump Micro drives are compatible for use with both three-phase and single-phase input power supplies. The drive output to the motor is always three-phase, regardless of number of input phases.

Output capacity to the motor is derated when using single-phase input power and the drive firmware includes protection for single-phase input applications. This protection is enabled by default. Disabling this protection for single-phase input applications can void warranty and result in premature failure.

Selection of larger models always results in greater output capacity to the motor when supplying the drive with three-phase input power. However, the selection of larger models does not always yield greater output capacity when using the drive with single-phase input power.

Several factors affect the amount of derated drive output capacity when single-phase input power is supplied to the drive:

- Single-phase input voltage level
- Motor voltage rating
- Amount of input impedance.

The tables in this section assist in model selection by considering factors that affect the amount of derating in single-phase input power applications.

### ■ Single-Phase Input Sizing

The rated output current listed in the tables allows for a 120% overload for 60 seconds. Contact Yaskawa if assistance is needed in selecting drive models with higher overload requirements. Adding more impedance than is specified will degrade performance.

Table A.9 240 V Single-Phase Input (-5% to +10%)

| Drive Model | Without Input Reactor   |                          |                           | With Input Reactor          |                         |                          |                           |
|-------------|-------------------------|--------------------------|---------------------------|-----------------------------|-------------------------|--------------------------|---------------------------|
|             | Rated Input Current (A) | Rated Output Current (A) | Max Applicable Motor (HP) | Yaskawa Reactor Part Number | Rated Input Current (A) | Rated Output Current (A) | Max Applicable Motor (HP) |
| 2V0006      | 7.3                     | 4.9                      | 1.0                       | URX000303                   | 7.3                     | 4.9                      | 1.0                       |
| 2V0010      | 10.8                    | 6.8                      | 1.5                       | URX000307                   | 10.8                    | 6.8                      | 1.5                       |
| 2V0012      | 13.9                    | 7.5                      | 2.0                       | URX000311                   | 13.9                    | 7.5                      | 2.0                       |
| 2V0020      | 24.0                    | 9.7                      | 2.0                       | URX000319                   | 24.0                    | 12.3                     | 3.0                       |
| 2V0030      | 37.0                    | 7.5                      | 2.0                       | URX000326                   | 37.0                    | 15.2                     | 3.0                       |
| 2V0040      | 52.0                    | 16.7                     | 5.0                       | URX000329                   | 52.0                    | 21.0                     | 5.0                       |
| 2V0056      | 68.0                    | 23.4                     | 5.0                       | URX000335                   | 68.0                    | 27.7                     | 7.5                       |
| 2V0069      | 80.0                    | 25.8                     | 7.5                       | URX000335                   | 80.0                    | 30.8                     | 10.0                      |

Table A.10 480 V Single-Phase Input (-5% to +10%)

| Drive Model | Without Input Reactor   |                          |                           | With Input Reactor          |                         |                          |                           |
|-------------|-------------------------|--------------------------|---------------------------|-----------------------------|-------------------------|--------------------------|---------------------------|
|             | Rated Input Current (A) | Rated Output Current (A) | Max Applicable Motor (HP) | Yaskawa Reactor Part Number | Rated Input Current (A) | Rated Output Current (A) | Max Applicable Motor (HP) |
| 4V0002      | 2.1                     | 1.3                      | 0.5                       | URX000292                   | 2.1                     | 1.7                      | 0.5                       |
| 4V0004      | 4.3                     | 2.4                      | 1.0                       | URX000300                   | 4.3                     | 2.8                      | 1.0                       |
| 4V0005      | 5.9                     | 3.5                      | 1.5                       | URX000304                   | 5.9                     | 3.9                      | 2.0                       |
| 4V0007      | 8.1                     | 3.5                      | 1.5                       | URX000309                   | 8.1                     | 5.4                      | 2.0                       |
| 4V0009      | 9.4                     | 5.1                      | 2.0                       | URX000308                   | 9.4                     | 5.5                      | 3.0                       |
| 4V0011      | 14.0                    | 5.5                      | 3.0                       | URX000312                   | 14.0                    | 7.5                      | 3.0                       |
| 4V0018      | 20.0                    | 4.5                      | 2.0                       | URX000316                   | 20.0                    | 8.7                      | 5.0                       |
| 4V0023      | 24.0                    | 5.5                      | 3.0                       | URX000320                   | 24.0                    | 10.5                     | 5.0                       |
| 4V0031      | 38.0                    | 7.9                      | 3.0                       | URX000327                   | 38.0                    | 13.5                     | 7.5                       |
| 4V0038      | 44.0                    | 11.3                     | 5.0                       | URX000327                   | 44.0                    | 16.1                     | 10.0                      |

### ◆ Temperature Derating

As the ambient temperature for the drive is increased above the drive specification the drive should be derated. Additionally parameter L8-35 Installation Method Selection on page 315 should be set according to enclosure type and mounting method as illustrated in *Figure A.1*.

### ■ Output Current Derating Due to Ambient Temperature

Set L8-12 and L8-35 according to the installation conditions when the ambient temperature is above the drive specification or when drives are mounted side-by-side in a cabinet. The output current is derated as shown in *Figure A.1*.

| No.   | Name                          | Description   | Range     | Def.          |
|-------|-------------------------------|---|-----------|---------------|
| L8-12 | Ambient Temperature Setting   | Adjust the drive overload (oL2) protection level when the drive is installed in an environment that exceeds its ambient temperature rating. | -10 to 50 | 40 °C         |
| L8-35 | Installation Method Selection | 0: IP20/IP00 Drive<br>1: Side-by-Side Mounting<br>2: NEMA 1, UL Type 1 Drive<br>3: Finless Drive or External Heatsink Installation          | 0 to 3    | Dep. on o2-04 |

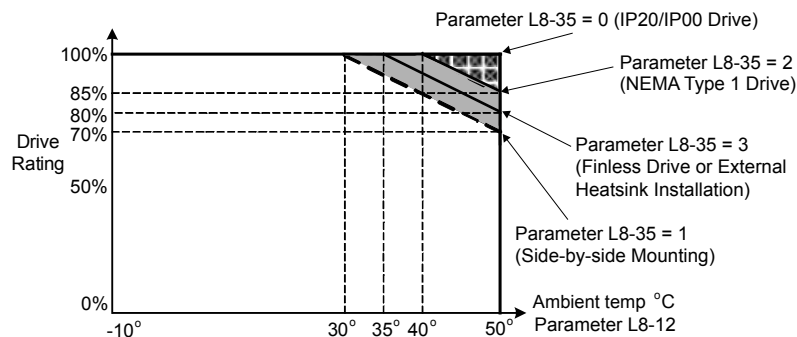


Figure A.1 Ambient Temperature and Installation Method Derating

### ◆ Altitude Derating

The drive standard ratings are valid for an installation altitude up to 1000 m. If the altitude exceeds 1000 m, both the drive input voltage and the rated output current must be derated for 1% per 100 m. The maximum altitude is 3000 m.

**This Page Intentionally Blank**

# Appendix: B

## Parameter List

---

This appendix contains a full listing of all parameters and settings available in the drive.

|             |  |            |
|-------------|--|------------|
| <b>B.1</b>  | <b>PARAMETER GROUPS.....</b>                       | <b>318</b> |
| <b>B.2</b>  | <b>A: INITIALIZATION PARAMETERS.....</b>           | <b>319</b> |
| <b>B.3</b>  | <b>B: APPLICATION.....</b>                         | <b>320</b> |
| <b>B.4</b>  | <b>C: TUNING.....</b>                              | <b>325</b> |
| <b>B.5</b>  | <b>D: REFERENCES.....</b>                          | <b>327</b> |
| <b>B.6</b>  | <b>E: MOTOR PARAMETERS.....</b>                    | <b>330</b> |
| <b>B.7</b>  | <b>F: OPTIONS.....</b>                             | <b>333</b> |
| <b>B.8</b>  | <b>H PARAMETERS: MULTI-FUNCTION TERMINALS.....</b> | <b>335</b> |
| <b>B.9</b>  | <b>L: PROTECTION FUNCTION.....</b>                 | <b>345</b> |
| <b>B.10</b> | <b>N: ADVANCED PERFORMANCE SET-UP.....</b>         | <b>352</b> |
| <b>B.11</b> | <b>O: OPERATOR RELATED PARAMETERS.....</b>         | <b>353</b> |
| <b>B.12</b> | <b>P: PUMP PARAMETERS.....</b>                     | <b>356</b> |
| <b>B.13</b> | <b>Q: PID CONTROLLER PARAMETERS.....</b>           | <b>366</b> |
| <b>B.14</b> | <b>S: SPECIAL APPLICATION.....</b>                 | <b>367</b> |
| <b>B.15</b> | <b>T: MOTOR TUNING.....</b>                        | <b>368</b> |
| <b>B.16</b> | <b>U: MONITORS.....</b>                            | <b>369</b> |
| <b>B.17</b> | <b>DEFAULTS BY DRIVE MODEL.....</b>                | <b>377</b> |


## B.1 Parameter Groups

| Parameter Group | Name   | Page                |
|-----------------|--|---------------------|
| A1              | Initialization                               | <a href="#">319</a> |
| A2              | User Parameters                              | <a href="#">319</a> |
| b1              | Operation Mode Selection                     | <a href="#">320</a> |
| b2              | DC Injection Braking                         | <a href="#">321</a> |
| b3              | Speed Search                                 | <a href="#">321</a> |
| b4              | Delay Timer                                  | <a href="#">322</a> |
| b5              | PID Control                                  | <a href="#">322</a> |
| b6              | Dwell Function                               | <a href="#">324</a> |
| C1              | Acceleration/Deceleration Time               | <a href="#">325</a> |
| C2              | S-Curve Accel/Decel                          | <a href="#">325</a> |
| C3              | Motor Slip Compensation                      | <a href="#">326</a> |
| C4              | Motor Torque Compensation                    | <a href="#">326</a> |
| C6              | Carrier Frequency                            | <a href="#">326</a> |
| d1              | Frequency Reference                          | <a href="#">327</a> |
| d2              | Reference Limits                             | <a href="#">328</a> |
| d3              | Jump Frequencies                             | <a href="#">328</a> |
| d4              | Frequency Reference Hold                     | <a href="#">329</a> |
| E1              | V/f Pattern                                  | <a href="#">330</a> |
| E2              | Motor Setup                                  | <a href="#">331</a> |
| F6              | Network Communications                       | <a href="#">333</a> |
| F7              | EtherNet/IP and Modbus TCP/IP Communications | <a href="#">333</a> |
| H1              | Digital Inputs                               | <a href="#">335</a> |
| H2              | Digital Outputs                              | <a href="#">339</a> |
| H3              | Analog Inputs                                | <a href="#">341</a> |
| H4              | Analog Outputs                               | <a href="#">343</a> |
| H5              | Serial Communications Setup                  | <a href="#">343</a> |
| H6              | Pulse Train I/O Setup                        | <a href="#">344</a> |
| L1              | Motor Overload                               | <a href="#">345</a> |
| L2              | Power Loss Ride-Thru                         | <a href="#">346</a> |

| Parameter Group | Name                      | Page                |
|-----------------|---------------------------|---------------------|
| L3              | Stall Prevention          | <a href="#">346</a> |
| L4              | Reference Detection       | <a href="#">348</a> |
| L5              | Fault Restart             | <a href="#">348</a> |
| L6              | Overtorque Detection      | <a href="#">349</a> |
| L8              | Hardware Protection       | <a href="#">350</a> |
| n1              | Hunting Prevention        | <a href="#">352</a> |
| n3              | High-Slip Braking         | <a href="#">352</a> |
| o1              | Monitor Display Selection | <a href="#">353</a> |
| o2              | Operator Keypad Functions | <a href="#">354</a> |
| o3              | Copy Function             | <a href="#">354</a> |
| o4              | Maintenance Functions     | <a href="#">355</a> |
| P1              | Pump Basic                | <a href="#">356</a> |
| P2              | Pump Protection           | <a href="#">358</a> |
| P4              | Pump Advanced             | <a href="#">359</a> |
| P5              | Pump HAND Mode            | <a href="#">361</a> |
| P7              | Anti-Jam                  | <a href="#">362</a> |
| P9              | Network Options           | <a href="#">362</a> |
| Q1              | Preset Setpoint           | <a href="#">366</a> |
| Q3              | Output Current Limit      | <a href="#">366</a> |
| S6              | Protection                | <a href="#">367</a> |
| T1              | Auto-Tuning               | <a href="#">368</a> |
| U1              | Status Monitor            | <a href="#">369</a> |
| U2              | Fault Trace               | <a href="#">372</a> |
| U3              | Fault History             | <a href="#">372</a> |
| U4              | Maintenance Monitor       | <a href="#">374</a> |
| U5              | PID Monitor               | <a href="#">376</a> |
| U6              | Control Monitor           | <a href="#">376</a> |
| U9              | Operation Status Monitors | <a href="#">376</a> |



## B.2 A: Initialization Parameters

Table B.1 Symbols and Icons Used in Parameter Descriptions

| Symbol  | Description                          |
|---|--------------------------------------|
|  | Parameter can be changed during run. |

The A parameter group creates the operating environment for the drive. This includes the parameter Access Level, Motor Control Method, Password, User Parameters and more.

### ◆ A1: Initialization

| No. (Addr. Hex)   | Name                   | LCD Display   | Description   | Values   | Page |
|---|------------------------|---|---|--|------|
| A1-00<br>(0100)<br><br><1> | Language Selection     | Select Language<br>0: English<br>1: ニホンゴ (Japanese)<br>2: Deutsch<br>3: Français<br>4: Italiano<br>5: Español<br>6: Português<br>7: 中文  | 0: English<br>1: Japanese<br>2: German<br>3: French<br>4: Italian<br>5: Spanish<br>6: Portuguese<br>7: Chinese  | Default: 0<br>Range: 0 to 7                                  | 110  |
| A1-01<br>(0101)<br><br><2> | Access Level Selection | Access Level<br>0: Operation Only<br>1: User Parameters<br>2: Advanced Level<br>3: Lock parameters  | 0: View and set A1-01 and A1-04. U□-□□ parameters can also be viewed.<br>1: User Parameters (access to parameters selected by the user, A2-01 to A2-32)<br>2: Advanced Access (access to view and set all parameters)<br>3: Lock parameters   | Default: 2<br>Range: 0 to 3                                  | 110  |
| A1-03<br>(0103)   | Initialize Parameters  | Init Parameters<br>0: No Initialize<br>1110: User Initialize<br>2220: 2-Wire Initial<br>3330: 3-Wire Initial<br>5550: Term->Cntrl Int<br>6008: Pressure Control<br>6009: Pump down level<br>7770: General purpose<br>7771: Sub Mtr GP Operation | 0: No initialization<br>1110: User Initialize (parameter values must be stored using parameter o2-03)<br>2220: 2-Wire initialization<br>3330: 3-Wire initialization<br>5550: Terminal->Control Initialize<br>6008: Pressure Control<br>6009: Pump down level<br>7770: General purpose<br>7771: Submersible motor GP operation | Default: 0<br>Range: 0 to 5550;<br>6008, 6009, 7770,<br>7771 | 111  |
| A1-04<br>(0104)   | Password               | Enter Password  | When the value set into A1-04 does not match the value set into A1-05, parameters A1-01 through A1-03 and A2-01 through A2-33 cannot be changed.  | Default: 0000<br>Min.: 0000<br>Max.: 9999                    | 112  |
| A1-05<br>(0105)   | Password Setting       | Select Password   |   |  |      |
| A1-06<br>(0127)   | Application Preset     | Application Sel<br>0: Pressure Control<br>1: General Purpose<br>2: Sub Mtr GP Operation<br>8: Pressure Control<br>9: Pump Down Level  | 0: Pressure control<br>1: General purpose<br>2: Submersible motor GP operation<br>8: Pressure control<br>9: Pump down level<br><br><b>Note:</b> This parameter is not settable. It is used as a monitor only.   | Default: 0<br>Range: 0 to 2; 8, 9                            | 86   |

<1> Parameter setting value is not reset to the default value when the drive is initialized.

<2> Default setting value is dependent on the Initialization parameter A1-03.

### ◆ A2: User Parameters

| No. (Addr. Hex)                        | Name                               | LCD Display                                | Description  | Values                                   | Page |
|--|------------------------------------|--|--|--|------|
| A2-01 to<br>A2-32<br>(0106 to<br>0125) | User Parameters 1 to 32            | User Param 1 - 32                          | Recently edited parameters are listed here. The user can also select parameters to appear here for quicker access.   | Default: <1><br>Range: b1-01 to<br>S6-02 | 113  |
| A2-33<br>(0126)                        | User Parameter Automatic Selection | User Parm Sel<br>0: Disabled<br>1: Enabled | 0: A2-01 to A2-32 are reserved for the user to create a list of User Parameters.<br>1: Save history of recently viewed parameters. Recently edited parameters will be saved to A2-17 through A2-32 for quicker access. | Default: 0<br>Range: 0, 1                | 113  |

<1> Default setting value is dependent on the Initialization parameter A1-03.

## B.3 b: Application

Application parameters configure the Run Command Source, Timer functions, PID control, and a variety of other application-related settings.

### ◆ b1: Operation Mode Selection

| No. (Addr. Hex) | Name   | LCD Display  | Description  | Values                                      | Page |
|-----------------|--|--|--|---|------|
| b1-01 (0180)    | Frequency Reference Selection 1              | Ref Source 1<br>0: Operator<br>1: Analog Input<br>2: Serial Com<br>3: Option PCB<br>4: Pulse Input | 0: Operator (will also switch PID setpoint to Q1-01)<br>1: Analog input terminals<br>2: MEMOBUS/Modbus communications<br>3: Option PCB<br>4: Pulse input (terminal RP)   | Default: 0<br>Range: 0 to 4                 | 115  |
| b1-02 (0181)    | Run Command Selection 1                      | Run Source 1<br>0: Operator<br>1: Digital Inputs<br>2: Communication<br>3: Option PCB              | 0: HOA keypad<br>1: Digital input terminals<br>2: MEMOBUS/Modbus communications<br>3: Option PCB   | Default: 0<br>Range: 0 to 3                 | 118  |
| b1-03 (0182)    | Stopping Method Selection                    | Stopping Method<br>0: Ramp to Stop<br>1: Coast to Stop<br>2: DCInj to Stop<br>3: Coast w/Timer     | 0: Ramp to stop<br>1: Coast to stop<br>2: DC Injection Braking to stop<br>3: Coast with timer  | Default: 1<br>Range: 0 to 3                 | 118  |
| b1-04 (0183)    | Reverse Operation Selection                  | Reverse Oper<br>0: Reverse Enabled<br>1: Reverse Disabled  | 0: Reverse enabled<br>1: Reverse disabled  | Default: 1<br>Range: 0, 1                   | 120  |
| b1-07 (0186)    | Run Command Retention when Source is Changed | RunCmd@SrcChange<br>0: Require Cycle<br>1: Retain Run Cmd  | Determines whether the run command is retained when the Sequence Selection is changed<br>0: Require Cycle<br>1: Retain Run Command   | Default: 0<br>Range: 0, 1                   | 121  |
| b1-08 (0187)    | Run Command Selection in Programming Mode    | RUN dur PRG Mode<br>0: Run Disabled@PRG<br>1: ModeRun Enabled@PRG<br>2: Prg only @ Stop            | 0: Run command is not accepted while in Programming Mode.<br>1: Run command is accepted while in Programming Mode.<br>2: Prohibit entering Programming Mode during run.  | Default: 0<br>Range: 0 to 2                 | 121  |
| b1-11 (01DF)    | Run Delay at Stop (Back Spin Timer)          | Run Delay @ Stop   | Sets the amount of time that the drive will disallow the reapplication of the Run command after the Run command is lost. b1-11 is active for all b1-03 settings. If set to zero and b1-03 = 3 (Coast to Stop w/ Timer), a combination of C1-02 and output frequency determine the length of time. Otherwise, no run delay will be applied. | Default: 0.0 s<br>Min.: 0.0<br>Max.: 6000.0 | –    |
| b1-12 (01E0)    | Run Delay Memory Selection                   | Run Dly Mem Sel  | Determines whether the Run Delay Timer is saved to the EEPROM during power loss.<br>0: Disabled<br>1: Only at Stop<br>2: Running & Stop<br><b>Note:</b> A JVOP-183 HOA Keypad must be plugged into the drive for settings 1 and 2 to function. If the keypad is removed, b1-12 will function as setting 0 (Disabled).                      | Default: 2<br>Range: 0 to 2                 | –    |
| b1-14 (01C3)    | Phase Order Selection                        | Rotation Sel<br>0: Standard<br>1: SwitchPhaseOrder   | 0: Standard<br>1: Switch phase order (reverses the direction of the motor)   | Default: 0<br>Range: 0, 1                   | 122  |
| b1-15 (01C4)    | Frequency Reference Selection 2              | Ref Source 2<br>0: Operator<br>1: Analog Input<br>2: Serial Com<br>3: Option PCB<br>4: Pulse Input | Enabled when a multi-function digital input set for “External Reference” (H1-□□ = 2) closes.<br>0: Operator<br>1: Analog Input<br>2: Serial Communications<br>3: Option PCB<br>4: Pulse Input  | Default: 0<br>Range: 0 to 4                 | 123  |



| No. (Addr. Hex) | Name                                    | LCD Display   | Description   | Values                      | Page |
|-----------------|---|---|---|-----------------------------|------|
| b1-16 (01C5)    | Run Command Selection 2<br>Run Source 2 | Run Source 2<br>0: Operator<br>1: Digital Inputs<br>2: Communication<br>3: Option PCB | Enabled when a multi-function digital input set for “External Reference” (H1-□□ = 2) closes.<br>0: Operator<br>1: Digital Inputs<br>2: Communication<br>3: Option PCB | Default: 0<br>Range: 0 to 3 | 123  |
| b1-17 (01C6)    | Run Command at Power Up                 | Run Cmd @ Pwr On<br>0: Cycle Ext Run<br>1: Accept Ext Run                             | 0: Disregarded. A new Run command must be issued after power up.<br>1: Allowed. Drive will run immediately after power up if a Run command is present.                | Default: 1<br>Range: 0, 1   | 123  |

◆ b2: DC Injection Braking and Short Circuit Braking

| No. (Addr. Hex) | Name                                 | LCD Display      | Description  | Values                                       | Page |
|-----------------|--------------------------------------|------------------|--|--|------|
| b2-01 (0189)    | DC Injection Braking Start Frequency | DCInj Start Freq | Sets the frequency at which DC Injection Braking starts when “Ramp to stop” (b1-03 = 0) is selected. | Default: 0.5 Hz<br>Min.: 0.0<br>Max.: 10.0   | 123  |
| b2-02 (018A)    | DC Injection Braking Current         | DCInj Current    | Sets the DC Injection Braking current as a percentage of the drive rated current.                    | Default: 50%<br>Min.: 0<br>Max.: 75          | 124  |
| b2-03 (018B)    | DC Injection Braking Time at Start   | DCInj Time@Start | Sets DC Injection Braking time at start. Disabled when set to 0.00 seconds.                          | Default: 0.00 s<br>Min.: 0.00<br>Max.: 10.00 | 124  |
| b2-04 (018C)    | DC Injection Braking Time at Stop    | DCInj Time@Stop  | Sets DC Injection Braking time at stop.  | Default: 0.50 s<br>Min.: 0.00<br>Max.: 10.00 | 124  |

◆ b3: Speed Search

| No. (Addr. Hex.) | Name   | LCD Display                                   | Description   | Values                                     | Page |
|------------------|--|---|---|--|------|
| b3-01 (0191)     | Speed Search Selection at Start                                  | SpdSrch at Start<br>0: Disabled<br>1: Enabled | 0: Disabled<br>1: Enabled   | Default: 0<br>Range: 0, 1                  | 127  |
| b3-02 (0192)     | Speed Search Deactivation Current                                | SpdSrch DeactCur                              | Sets the current level at which the speed is assumed to be detected and Speed Search is ended. Set as a percentage of the drive rated current.  | Default: 120%<br>Min.: 0<br>Max.: 200      | 127  |
| b3-03 (0193)     | Speed Search Deceleration Time                                   | SpdSrch Dec Time                              | Sets output frequency reduction time during Speed Search.   | Default: 2.0 s<br>Min.: 0.1<br>Max.: 10.0  | 127  |
| b3-05 (0195)     | Speed Search Delay Time  | Search Delay                                  | When using an external contactor on the output side, b3-05 delays executing Speed Search after a momentary power loss to allow time for the contactor to close.   | Default: 0.2 s<br>Min.: 0.0<br>Max.: 100.0 | 127  |
| b3-06 (0196)     | Output Current 1 during Speed Search                             | Srch Im Lvl1                                  | Sets the current injected to the motor at the beginning of Speed Estimation Speed Search. Set as a coefficient for the motor rated current.   | Default: <I><br>Min.: 0.0<br>Max.: 2.0     | 128  |
| b3-08 (0198)     | Current Control Gain during Speed Search (Speed Estimation Type) | Srch ACR P Gain                               | Sets the proportional gain for the current controller during Speed Search.  | Default: 0.50<br>Min.: 0.00<br>Max.: 6.00  | 128  |
| b3-10 (019A)     | Speed Search Detection Compensation Gain                         | Srch Detect Comp                              | Sets the gain which is applied to the speed detected by Speed Estimation Speed Search before the motor is reaccelerated. Increase this setting if ov occurs when performing Speed Search after a relatively long period of baseblock. | Default: 1.05<br>Min.: 1.00<br>Max.: 1.20  | 128  |
| b3-14 (019E)     | Bi-Directional Speed Search Selection                            | Bidir Search Sel<br>0: Disabled<br>1: Enabled | 0: Disabled (uses the direction of the frequency reference)<br>1: Enabled (drive detects which way the motor is rotating)   | Default: 0<br>Range: 0, 1                  | 128  |

## B.3 b: Application

| No. (Addr Hex.) | Name                                | LCD Display  | Description   | Values                                      | Page |
|-----------------|-------------------------------------|--|---|---|------|
| b3-17 (01F0)    | Speed Search Restart Current Level  | SrchRestart Lvl  | Sets the Speed Search restart current level as a percentage of the drive rated current. | Default: 150%<br>Min.: 0<br>Max.: 200       | 128  |
| b3-18 (01F1)    | Speed Search Restart Detection Time | SrchRestart Time   | Sets the time to detect Speed Search restart.   | Default: 0.10 s<br>Min.: 0.00<br>Max.: 1.00 | 128  |
| b3-19 (01F2)    | Number of Speed Search Restarts     | Num of SrchRestr   | Sets the number of times the drive can attempt to restart when performing Speed Search. | Default: 3<br>Min.: 0<br>Max.: 10           | 129  |
| b3-24 (01C0)    | Speed Search Method Selection       | SpdSrch Method<br>0: CurrentDetection<br>1: Speed Estimation | 0: Current Detection<br>1: Speed Estimation   | Default: 0<br>Range: 0, 1                   | 129  |
| b3-25 (01C8)    | Speed Search Wait Time              | SpdSrch WaitTime   | Sets the time the drive must wait between each Speed Search restart attempt.            | Default: 0.5 s<br>Min.: 0.0<br>Max.: 30.0   | 129  |

<1> Default setting is dependent on parameter o2-04, Drive Model Selection.

## ◆ b4: Timer Function

| No. (Addr. Hex) | Name                          | LCD Display     | Description   | Values                                     | Page |
|-----------------|-------------------------------|-----------------|---|--|------|
| b4-01 (01A3)    | Timer Function On-Delay Time  | Delay-ON Timer  | Sets the on-delay and off-delay times for a digital timer output (H2-□□=12).<br>The output is triggered by a digital input programmed to H1-□□=18). | Default: 0.0 s<br>Min.: 0.0<br>Max.: 300.0 | 129  |
| b4-02 (01A4)    | Timer Function Off-Delay Time | Delay-OFF Timer |   | Default: 0.0 s<br>Min.: 0.0<br>Max.: 300.0 | 129  |

## ◆ b5: PID Control

| No. (Addr. Hex)     | Name                            | LCD Display                                  | Description  | Values                                       | Page     |
|---------------------|---------------------------------|--|--|--|----------|
| b5-01 (01A5)        | PID Function Setting            | PID Mode<br>0: Disabled<br>1: Enabled D=Fdbk | 0: Disabled<br>1: Enabled (PID output becomes output frequency reference, deviation D controlled)                | Default: 1<br>Range: 0, 1                    | 133      |
| b5-02 (01A6)<br>RUN | Proportional Gain Setting (P)   | PID Gain                                     | Sets the proportional gain of the PID controller.  | Default: 2.00<br>Min.: 0.00<br>Max.: 25.00   | 133      |
| b5-03 (01A7)<br>RUN | Integral Time Setting (I)       | PID I Time                                   | Sets the integral time for the PID controller.   | Default: 3.0 s<br>Min.: 0.0<br>Max.: 360.0   | 133      |
| b5-04 (01A8)<br>RUN | Integral Limit Setting          | PID I Limit                                  | Sets the maximum output possible from the integrator as a percentage of the maximum output frequency.            | Default: 100.0%<br>Min.: 0.0<br>Max.: 100.0  | 134      |
| b5-05 (01A9)<br>RUN | Derivative Time (D)             | PID D Time                                   | Sets D control derivative time.  | Default: 0.00 s<br>Min.: 0.00<br>Max.: 10.00 | —<br>134 |
| b5-06 (01AA)<br>RUN | PID Output Limit                | PID Limit                                    | Sets the maximum output possible from the entire PID controller as a percentage of the maximum output frequency. | Default: 100.0%<br>Min.: 0.0<br>Max.: 100.0  | 134      |
| b5-07 (01AB)<br>RUN | PID Offset Adjustment           | PID Offset                                   | Applies an offset to the PID controller output. Set as a percentage of the maximum output frequency.             | Default: 0.0%<br>Min.: -100.0<br>Max.: 100.0 | 134      |
| b5-08 (01AC)<br>RUN | PID Primary Delay Time Constant | PID Delay Time                               | Sets a low pass filter time constant on the output of the PID controller.  | Default: 0.00 s<br>Min.: 0.00<br>Max.: 10.00 | 134      |

| No. (Addr. Hex)     | Name   | LCD Display   | Description  | Values   | Page |
|---------------------|--|---|--|--|------|
| b5-09 (01AD)        | PID Output Level Selection                     | Output Level Sel<br>0: Direct Acting<br>1: Inverse Acting   | 0: Direct acting<br>1: Inverse acting  | Default: 0<br>Range: 0, 1                          | 133  |
| b5-10 (01AE)<br>RUN | PID Output Gain Setting                        | Output Gain   | Sets the gain applied to the PID output.   | Default: 1.00<br>Min.: 0.00<br>Max.: 25.00         | 134  |
| b5-11 (01AF)        | PID Output Reverse Selection                   | Output Rev Sel<br>0: 0 limit<br>1: Reverse  | 0: Negative PID output triggers zero limit.<br>1: Rotation direction reverses with negative PID output.<br><b>Note:</b> When using setting 1, make sure reverse operation is permitted by b1-04.   | Default: 0<br>Range: 0, 1                          | 134  |
| b5-12 (01B0)        | Feedback Loss 4 to 20 mA Detection Selection   | Fdbk 4-20mA Det<br>0: Disabled<br>1: Alarm only<br>2: Fault<br>3: Run At b5-13                      | Performs a 4 to 20 mA wire break detection on the analog input that is programmed for PID feedback.<br>0: Disabled<br>1: Alarm only<br>2: Fault<br>3: Run at b5-13   | Default: 2<br>Range: 0 to 3                        | 135  |
| b5-13 (01B1)        | Feedback Loss Goto Frequency                   | FdbkLossGotoFreq  | Sets the speed at which the drive will run if a 4 to 20 mA wire break is detected on the PID Feedback and when b5-12 is set to 3 (Run at b5-13).   | Default: 0.0 Hz<br>Min.: 0.0<br>Max.: 400.0        | 136  |
| b5-14 (01B2)<br>RUN | Feedback Loss of Prime Level                   | FdbkLoss LOP Lvl  | Detects loss of prime in the pump when a wire break condition has occurred.<br>When the measured quantity determined by P1-18 (output current, kilowatts, or power) drops below this level for the time set in P1-20 and the output frequency is at the level set in b5-13, a "Loss of Prime" condition occurs.<br>The drive responds to the "Loss of Prime" condition depending on the setting of P1-22, Loss of Prime Selection. | Default: 0.0 A<br><1><br>Min.: 0.0<br>Max.: 1000.0 | 136  |
| b5-15 (01B3)<br>RUN | Feedback Loss Go To Frequency Time Out         | FdbkLossGotoTimO  | When b5-12 = 3 and the Feedback signal is lost, the drive will run at the b5-13 speed for the b5-15 time, after which the drive will fault on Feedback Loss (FDBKL).<br>Timeout is disabled when set to 0sec and the drive will run indefinitely at b5-13.   | Default: 0 s<br>Min.: 0<br>Max.: 6000              | 136  |
| b5-16 (01B4)<br>RUN | Feedback Loss Start Delay                      | FdbkLossStartDly  | When an AUTO Run command is initiated, the drive will not fault on Feedback Loss (FDBKL) or use the Feedback Loss GoTo Frequency (b5-13) until the b5-16 time has expired.   | Default: 0.0 s<br>Min.: 0.0<br>Max.: 120.0         | 136  |
| b5-17 (01B5)        | PID Accel/Decel Time                           | PID Acc/Dec Time  | Sets the acceleration and deceleration time to PID setpoint.   | Default: 0 s<br>Min.: 0<br>Max.: 255               | 137  |
| b5-32 (01EE)<br>RUN | Integrator Ramp Limit                          | IntegratrRampLim  | When set to a value greater than zero, the PID Integrator is forced to be within +/- this amount of the soft starter output.   | Default: 0.0 Hz<br>Min.: 0.0<br>Max.: 10.0         | 137  |
| b5-34 (019F)<br>RUN | PID Output Lower Limit                         | PID Out Low Lim   | Sets the minimum output possible from the PID controller as a percentage of the maximum output frequency.  | Default: 0.00%<br>Min.: -100.00<br>Max.: 100.00    | 137  |
| b5-35 (01A0)<br>RUN | PID Input Limit                                | PID Input Limit   | Limits the PID control input (deviation signal) as a percentage of the maximum output frequency. Acts as a bipolar limit.  | Default: 1000.0%<br>Min.: 0.0<br>Max.: 1000.0      | 137  |
| b5-39 (01FF)        | PID System Units Display Digits                | PID UstrDspDigits<br>0: No Dec (XXXXX)<br>1: 1 Dec (XXX.X)<br>2: 2 Dec (XX.XX)<br>3: 3 Dec (XX.XXX) | Determines the number of digits in the user-defined display for the PID parameters and monitors (Q1-□□, U5-99, etc).<br>0: No decimal place<br>1: One decimal place<br>2: Two decimal places<br>3: Three decimal places  | Default: 1<br>Range: 0 to 3                        | 137  |
| b5-40 (017F)        | Frequency Reference Monitor Content during PID | Fref Mon Sel@PID<br>0: Fref Mon w PID<br>1: Fref Mon w/o PID  | 0: Display the frequency reference (U1-01) after PID compensation has been added.<br>1: Display the frequency reference (U1-01) before PID compensation has been added.  | Default: 0<br>Range: 0, 1                          | 138  |
| b5-47 (017D)        | Reverse Operation Selection 2 by PID Output    | Output Rev Sel2<br>0: 0 Limit<br>1: Reverse   | 0: Zero limit when PID output is a negative value.<br>1: Reverse operation when PID output is a negative value (Zero limit if the reverse operation is prohibited by b1-04).   | Default: 1<br>Range: 0, 1                          | 138  |

<1> Unit text is set by P1-18, Prime Loss Detection Method.

**◆ b6: Dwell Function**

| No.<br>(Addr.<br>Hex) | Name                     |                   | Description  | Values                                      | Page                |
|-----------------------|--------------------------|-------------------|--|---|---------------------|
| b6-01<br>(01B6)       | Dwell Reference at Start | Dwell Ref @Start  | Parameters b6-01 and b6-02 set the frequency to hold and the time to maintain that frequency at start. | Default: 0.0 Hz<br>Min.: 0.0<br>Max.: 400.0 | <a href="#">138</a> |
| b6-02<br>(01B7)       | Dwell Time at Start      | Dwell Time @Start |  | Default: 0.0 s<br>Min.: 0.0<br>Max.: 10.0   | <a href="#">138</a> |
| b6-03<br>(01B8)       | Dwell Reference at Stop  | Dwell Ref @Stop   | Parameters b6-03 and b6-04 set the frequency to hold and the time to maintain that frequency at stop.  | Default: 0.0 Hz<br>Min.: 0.0<br>Max.: 400.0 | <a href="#">139</a> |
| b6-04<br>(01B9)       | Dwell Time at Stop       | Dwell Time @Stop  |  | Default: 0.0 s<br>Min.: 0.0<br>Max.: 10.0   | <a href="#">139</a> |

## B.4 C: Tuning

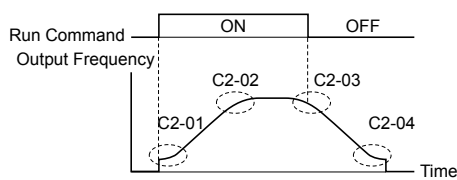
C parameters are used to adjust the acceleration and deceleration times, S-curves, slip and torque compensation functions and carrier frequency selections.

### ◆ C1: Acceleration and Deceleration Times

| No. (Addr. Hex)        | Name                                 | LCD Display  | Description  | Values  | Page |
|------------------------|--------------------------------------|--|--|---|------|
| C1-01<br>(0200)<br>RUN | Acceleration Time 1                  | Accel Time 1                                       | Sets the time to accelerate from 0 to maximum frequency.   | Default: 20.0 s<br>Min.: 0.0<br>Max.: 6000.0<br></> | 140  |
| C1-02<br>(0201)<br>RUN | Deceleration Time 1                  | Decel Time 1                                       | Sets the time to decelerate from maximum frequency to 0.   |   | 140  |
| C1-03<br>(0202)<br>RUN | Acceleration Time 2                  | Accel Time 2                                       | Sets the time to accelerate from 0 to maximum frequency.   | Default: 10.0 s<br>Min.: 0.0<br>Max.: 6000.0<br></> | 140  |
| C1-04<br>(0203)<br>RUN | Deceleration Time 2                  | Decel Time 2                                       | Sets the time to decelerate from maximum frequency to 0.   |   | 140  |
| C1-09<br>(0208)<br>RUN | Fast Stop Time                       | Fast Stop Time                                     | Sets the time for the Fast Stop function.  | Default: 10.0 s<br>Min.: 0.0<br>Max.: 6000.0<br></> | 140  |
| C1-10<br>(0209)        | Accel/Decel Time Setting Units       | Acc/Dec Units<br>0: 0.01 Seconds<br>1: 0.1 Seconds | 0: 0.01 s (0.00 to 600.00 s)<br>1: 0.1 s (0.0 to 6000.0 s)   | Default: 1<br>Range: 0, 1                           | 141  |
| C1-11<br>(020A)        | Accel/Decel Time Switching Frequency | Acc/Dec SW Freq                                    | Sets the frequency to switch between accel/dec time settings.  | Default: 0.0 Hz<br>Min.: 0.0<br>Max.: 400.0         | 141  |
| C1-14<br>(0264)        | Accel/Decel Rate Frequency           | Acc/DecRate Freq                                   | Sets the base frequency used to calculate acceleration and deceleration times.<br>When set to 0.0 Hz, the drive calculates the time required to accelerate from 0 Hz to E1-04, and decelerate from E1-04 down to 0 Hz (conventional setting).<br>When set to any other value above 0.0 Hz, the drive calculates the time required to accelerate from 0 Hz to C1-14, and to decelerate from C1-14 down to 0 Hz. | Default: 0.0 Hz<br>Min.: 0.0<br>Max.: 400.0         | 141  |

</> Setting range value is dependent on parameter C1-10, Accel/Decel Time Setting Units. When C1-10 = 0 (units of 0.01 seconds), the setting range becomes 0.00 to 600.00 seconds.

### ◆ C2: S-Curve Characteristics

| No. (Addr. Hex) | Name                                  | LCD Display      | Description   | Values                                       | Page |
|-----------------|---------------------------------------|------------------|---|--|------|
| C2-01<br>(020B) | S-Curve Characteristic at Accel Start | SCrv Acc @ Start | <p>The S-curve can be controlled at the four points shown below.</p>  | Default: 0.20 s<br>Min.: 0.00<br>Max.: 10.00 | 143  |
| C2-02<br>(020C) | S-Curve Characteristic at Accel End   | SCrv Acc @ End   |   | Default: 0.20 s<br>Min.: 0.00<br>Max.: 10.00 | 143  |
| C2-03<br>(020D) | S-Curve Characteristic at Decel Start | SCrv Dec @ Start |   | Default: 0.20 s<br>Min.: 0.00<br>Max.: 10.00 | 143  |
| C2-04<br>(020E) | S-Curve Characteristic at Decel End   | SCrv Dec @ End   |   | Default: 0.00 s<br>Min.: 0.00<br>Max.: 10.00 | 143  |

◆ C3: Slip Compensation

| No. (Addr. Hex)     | Name  | LCD Display                                     | Description   | Values                                     | Page |
|---------------------|---|---|---|--|------|
| C3-01 (020F)<br>RUN | Slip Compensation Gain                          | Slip Comp                                       | Sets the gain for the motor slip compensation function used for motor 1.  | Default: 0.0<br>Min.: 0.0<br>Max.: 2.5     | 143  |
| C3-02 (0210)<br>RUN | Slip Compensation Primary Delay Time            | Slip Comp Time                                  | Adjusts the slip compensation function delay time used for motor 1.   | Default: 2000 ms<br>Min.: 0<br>Max.: 10000 | 143  |
| C3-03 (0211)        | Slip Compensation Limit                         | Slip Comp Limit                                 | Sets an upper limit for the slip compensation function as a percentage of motor rated slip for motor 1 (E2-02). | Default: 200%<br>Min.: 0<br>Max.: 250      | 143  |
| C3-04 (0212)        | Slip Compensation Selection during Regeneration | Slip Comp Regen<br>0: Disabled<br>1: Above 6 Hz | 0: Disabled.<br>1: Enabled above 6 Hz   | Default: 0<br>Range: 0, 1                  | 144  |

◆ C4: Torque Compensation

| No. (Addr. Hex)     | Name                                     | LCD Display    | Description  | Values                                    | Page |
|---------------------|--|----------------|--|---|------|
| C4-01 (0215)<br>RUN | Torque Compensation Gain                 | Torq Comp Gain | Sets the gain for the automatic torque (voltage) boost function and helps to produce better starting torque. Used for motor 1. | Default: 1.00<br>Min.: 0.00<br>Max.: 2.50 | 144  |
| C4-02 (0216)<br>RUN | Torque Compensation Primary Delay Time 1 | Torq Comp Time | Sets the torque compensation filter time.  | Default: 200 ms<br>Min.: 0<br>Max.: 60000 | 144  |

◆ C6: Carrier Frequency

| No. (Addr. Hex) | Name                                | LCD Display   | Description   | Values                                      | Page |
|-----------------|-------------------------------------|---|---|---|------|
| C6-02 (0224)    | Carrier Frequency Selection         | CarrierFreq Sel<br>1: 2.0 kHz<br>2: 5.0 kHz<br>3: 8.0 kHz<br>4: 10.0 kHz<br>5: 12.5 kHz<br>6: 15.0 kHz<br>7: Swing PWM1 (Audible sound 1)<br>8: Swing PWM2 (Audible sound 2)<br>9: Swing PWM3 (Audible sound 3)<br>A: Swing PWM4 (Audible sound 4)<br>B: Leakage Rejection PWM<br>C to E: No setting possible<br>F: Program | 1: 2.0 kHz<br>2: 5.0 kHz (4.0 kHz)<br>3: 8.0 kHz (6.0 kHz)<br>4: 10.0 kHz (8.0 kHz)<br>5: 12.5 kHz (10.0 kHz)<br>6: 15.0 kHz (12.0 kHz)<br>7: Swing PWM1 (Audible sound 1)<br>8: Swing PWM2 (Audible sound 2)<br>9: Swing PWM3 (Audible sound 3)<br>A: Swing PWM4 (Audible sound 4)<br>B: Leakage Current Rejection PWM<br>C to E: No setting possible<br>F: User-defined (determined by C6-03 through C6-05) | Default: 7<br>Range: 1 to B; F              | 145  |
| C6-03 (0225)    | Carrier Frequency Upper Limit       | CarrierFreq Max   | <p>Determines the upper and lower limits for the carrier frequency.</p>   | Default: 2.0 kHz<br>Min.: 1.0<br>Max.: 15.0 | 146  |
| C6-04 (0226)    | Carrier Frequency Lower Limit       | CarrierFreq Min   |   | Default: 2.0 kHz<br>Min.: 1.0<br>Max.: 15.0 | 146  |
| C6-05 (0227)    | Carrier Frequency Proportional Gain | CarrierFreq Gain  |   | Default: 0<br>Min.: 0<br>Max.: 99           | 146  |

## B.5 d: References

Reference parameters are used to set the various frequency reference values during operation.

### ◆ d1: Frequency Reference

| No.<br>(Addr.<br>Hex)  | Name                   | LCD Display  | Description  | Values  | Page |
|------------------------|------------------------|--------------|--|---|------|
| d1-01<br>(0280)<br>RUN | Frequency Reference 1  | Reference 1  | Sets the frequency reference for the drive. Setting units are determined by parameter o1-03.                 | Default: 0.00 Hz<br>Min.: 0.00<br>Max.: 400.00<br></> | 147  |
| d1-02<br>(0281)<br>RUN | Frequency Reference 2  | Reference 2  | Frequency reference when digital input "Multi-Step Speed Reference 1" (H1-□□ = 3) is on.                     | Default: 0.00 Hz<br>Min.: 0.00<br>Max.: 400.00<br></> | 147  |
| d1-03<br>(0282)<br>RUN | Frequency Reference 3  | Reference 3  | Frequency reference when digital input "Multi-Step Speed Reference 2" (H1-□□ = 4) is on.                     | Default: 0.00 Hz<br>Min.: 0.00<br>Max.: 400.00<br></> | 147  |
| d1-04<br>(0283)<br>RUN | Frequency Reference 4  | Reference 4  | Frequency reference when digital inputs "Multi-Step Speed Reference 1, 2" (H1-□□ = 3 and 4) are on.          | Default: 0.00 Hz<br>Min.: 0.00<br>Max.: 400.00<br></> | 147  |
| d1-05<br>(0284)<br>RUN | Frequency Reference 5  | Reference 5  | Frequency reference when digital input "Multi-Step Speed Reference 3" (H1-□□ = 5) is on.                     | Default: 0.00 Hz<br>Min.: 0.00<br>Max.: 400.00<br></> | 147  |
| d1-06<br>(0285)<br>RUN | Frequency Reference 6  | Reference 6  | Frequency reference when digital inputs "Multi-Step Speed Reference 1, 3" (H1-□□ = 3 and 5) are on.          | Default: 0.00 Hz<br>Min.: 0.00<br>Max.: 400.00<br></> | 147  |
| d1-07<br>(0286)<br>RUN | Frequency Reference 7  | Reference 7  | Frequency reference when digital inputs "Multi-Step Speed Reference 2, 3" (H1-□□ = 4 and 5) are on.          | Default: 0.00 Hz<br>Min.: 0.00<br>Max.: 400.00<br></> | 147  |
| d1-08<br>(0287)<br>RUN | Frequency Reference 8  | Reference 8  | Frequency reference when multi-function input "Multi-Step speed reference 1, 2, 3" (H1-□□ = 3, 4, 5) are on. | Default: 0.00 Hz<br>Min.: 0.00<br>Max.: 400.00<br></> | 147  |
| d1-09<br>(0288)<br>RUN | Frequency Reference 9  | Reference 9  | Frequency reference when multi-function input "Multi-Step Speed Reference 4" (H1-□□ = 32) is on.             | Default: 0.00 Hz<br>Min.: 0.00<br>Max.: 400.00<br></> | 147  |
| d1-10<br>(028B)<br>RUN | Frequency Reference 10 | Reference 10 | Frequency reference when digital input "Multi-Step Speed Reference 1, 4" (H1-□□ = 3 and 32) are on.          | Default: 0.00 Hz<br>Min.: 0.00<br>Max.: 400.00<br></> | 147  |
| d1-11<br>(028C)<br>RUN | Frequency Reference 11 | Reference 11 | Frequency reference when digital inputs "Multi-Step Speed Reference 2, 4" (H1-□□ = 4 and 32) are on.         | Default: 0.00 Hz<br>Min.: 0.00<br>Max.: 400.00<br></> | 147  |
| d1-12<br>(028D)<br>RUN | Frequency Reference 12 | Reference 12 | Frequency reference when digital inputs "Multi-Step Speed Reference 1, 2, 4" (H1-□□ = 3, 4, 32) are on.      | Default: 0.00 Hz<br>Min.: 0.00<br>Max.: 400.00<br></> | 147  |
| d1-13<br>(028E)<br>RUN | Frequency Reference 13 | Reference 13 | Frequency reference when digital inputs "Multi-Step Speed Reference 3, 4" (H1-□□ = 5 and 32) are on.         | Default: 0.00 Hz<br>Min.: 0.00<br>Max.: 400.00<br></> | 147  |

## B.5 d: References

| No. (Addr. Hex)        | Name                    | LCD Display   | Description   | Values  | Page |
|------------------------|-------------------------|---------------|---|---|------|
| d1-14<br>(028F)<br>RUN | Frequency Reference 14  | Reference 14  | Frequency reference when digital inputs "Multi-Step Speed Reference 1, 3, 4" (H1-□□ = 3, 5, 32) are on.   | Default: 0.00 Hz<br>Min.: 0.00<br>Max.: 400.00<br><I> | 147  |
| d1-15<br>(0290)<br>RUN | Frequency Reference 15  | Reference 15  | Frequency reference when digital inputs "Multi-Step Speed Reference 2, 3, 4" (H1-□□ = 4, 5, 32) are on.   | Default: 0.00 Hz<br>Min.: 0.00<br>Max.: 400.00<br><I> | 147  |
| d1-16<br>(0291)<br>RUN | Frequency Reference 16  | Reference 16  | Frequency reference when digital inputs "Multi-Step Speed Reference 1, 2, 3, 4" (H1-□□ = 3, 4, 5, 32) are on.   | Default: 0.00 Hz<br>Min.: 0.00<br>Max.: 400.00<br><I> | 147  |
| d1-17<br>(0292)<br>RUN | Jog Frequency Reference | Jog Reference | Frequency reference when digital inputs "Jog Frequency Reference", "Forward Jog", or "Reverse Jog." are on. "Jog Frequency Reference" has priority over "Multi-Step Speed Reference 1 to 16". | Default: 6.00 Hz<br>Min.: 0.00<br>Max.: 400.00<br><I> | 147  |

<I> Range upper limit is determined by parameters d2-01, Frequency Reference Upper Limit, and E1-04, Maximum Output Frequency.

### ◆ d2: Frequency Upper/Lower Limits

| No. (Addr. Hex) | Name                               | LCD Display      | Description   | Setting                                     | Page |
|-----------------|------------------------------------|------------------|---|---|------|
| d2-01<br>(0289) | Frequency Reference Upper Limit    | Ref Upper Limit  | Sets the frequency reference upper limit as a percentage of the maximum output frequency.                         | Default: 100.0%<br>Min.: 0.0<br>Max.: 110.0 | 148  |
| d2-02<br>(028A) | Frequency Reference Lower Limit    | Ref Lower Limit  | Sets the frequency reference lower limit as a percentage of the maximum output frequency.                         | Default: 0.0%<br>Min.: 0.0<br>Max.: 110.0   | 148  |
| d2-03<br>(0293) | Master Speed Reference Lower Limit | Ref1 Lower Limit | Sets the lower limit for frequency references from analog inputs as a percentage of the maximum output frequency. | Default: 0.0%<br>Min.: 0.0<br>Max.: 110.0   | 149  |

### ◆ d3: Jump Frequency

| No. (Addr. Hex) | Name                 | LCD Display    | Description  | Values                                      | Page |
|-----------------|----------------------|----------------|--|---|------|
| d3-01<br>(0294) | Jump Frequency 1     | Jump Freq 1    | Eliminates problems with resonant vibration of the motor/machine by avoiding continuous operation in predefined frequency ranges. The drive accelerates and decelerates the motor through the prohibited frequency ranges. Parameters must be set so that $d3-01 \geq d3-02 \geq d3-03$ . Setting this parameter to 0.0 disables the function. | Default: 0.0 Hz<br>Min.: 0.0<br>Max.: 400.0 | 149  |
| d3-02<br>(0295) | Jump Frequency 2     | Jump Freq 2    |  | Default: 0.0 Hz<br>Min.: 0.0<br>Max.: 400.0 | 149  |
| d3-03<br>(0296) | Jump Frequency 3     | Jump Freq 3    |  | Default: 0.0 Hz<br>Min.: 0.0<br>Max.: 400.0 | 149  |
| d3-04<br>(0297) | Jump Frequency Width | Jump Bandwidth | Sets the dead-band width around each selected prohibited frequency reference point.  | Default: 1.0 Hz<br>Min.: 0.0<br>Max.: 20.0  | 149  |



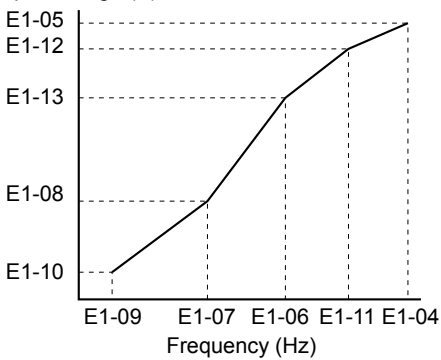
## ◆ d4: Frequency Reference Hold and Up/Down 2 Function

| No. (Addr. Hex)     | Name  | LCD Display   | Description   | Values  | Page |
|---------------------|---|---|---|---|------|
| d4-01 (0298)        | Frequency Reference Hold Function Selection                   | Fref Hold Sel<br>0: Disabled<br>1: Enabled                    | 0: Disabled. Drive starts from zero when the power is switched on.<br>1: Enabled. At power up, the drive starts the motor at the Hold frequency that was saved.   | Default: 0<br>Range: 0, 1                     | 150  |
| d4-03 (02AA)<br>RUN | Frequency Reference Bias Step (Up/Down 2)                     | Up/Dn 2 Step Lvl  | Sets the bias added to the frequency reference when the Up 2 and Down 2 digital inputs are enabled (H1-□□ = 75, 76).  | Default: 0.00 Hz<br>Min.: 0.00<br>Max.: 99.99 | 152  |
| d4-05 (02AC)<br>RUN | Frequency Reference Bias Operation Mode Selection (Up/Down 2) | Up/Dn 2 Bias Sel<br>0: Hold Bias Value<br>1: Reset Bias Value | 0: Bias value is held if no input Up 2 or Down 2 is active.<br>1: When the Up 2 reference and Down 2 reference are both on or both off, the applied bias becomes 0. The specified accel/ decel times are used for acceleration or deceleration.   | Default: 0<br>Range: 0, 1                     | 153  |
| d4-06 (02AD)        | Frequency Reference Bias (Up/Down 2)                          | Up/Dn 2 Bias Lvl  | The Up/Down 2 bias value is saved in d4-06 when the frequency reference is not input by the digital operator. Set as a percentage of the maximum output frequency.  | Default: 0.0%<br>Min.: -99.9<br>Max.: 100.0   | 153  |
| d4-07 (02AE)<br>RUN | Analog Frequency Reference Fluctuation Limit (Up/Down 2)      | Up/Dn 2 FluctLim  | Limits how much the frequency reference is allowed to change while an input terminal set for Up 2 or Down 2 is enabled. If the frequency reference changes for more than the set value, then the bias value is held and the drive accelerates or decelerates to the frequency reference. Set as a percentage of the maximum output frequency. | Default: 1.0%<br>Min.: 0.1<br>Max.: 100.0     | 154  |
| d4-08 (2AF)<br>RUN  | Frequency Reference Bias Upper Limit (Up/Down 2)              | Up/Dn 2 UpperLim  | Sets the upper limit for the bias and the value that can be saved in d4-06. Set as a percentage of the maximum output frequency.  | Default: 100.0%<br>Min.: 0.0<br>Max.: 100.0   | 154  |
| d4-09 (02B0)<br>RUN | Frequency Reference Bias Lower Limit (Up/Down 2)              | Up/Dn 2 LowerLim  | Sets the lower limit for the bias and the value that can be saved in d4-06. Set as a percentage of the maximum output frequency.  | Default: 0.0%<br>Min.: -99.9<br>Max.: 0.0     | 154  |
| d4-10 (02B6)        | Up/Down Frequency Reference Limit Selection                   | Up/Dn LowLim Sel<br>0: D2-02 or Analog<br>1: D2-02 Only       | 0: The lower limit is determined by d2-02 or an analog input.<br>1: The lower limit is determined by d2-02.   | Default: 0<br>Range: 0, 1                     | 154  |

## B.6 E: Motor Parameters

### ◆ E1: V/f Pattern

| No. (Addr. Hex) | Name                  | LCD Display  | Description   | Values                                   | Page |
|-----------------|-----------------------|--|---|--|------|
| E1-01 (0300)    | Input Voltage Setting | Input Voltage  | <p>This parameter must be set to the power supply voltage.</p> <p><b>WARNING!</b> <i>Electrical Shock Hazard. Drive input voltage (not motor voltage) must be set in E1-01 for the protective features of the drive to function properly. Failure to do so may result in equipment damage and/or death or personal injury.</i></p>  | Default: 230 V<br>Min.: 155<br>Max.: 255 | 155  |
| E1-03 (0302)    | V/f Pattern Selection | V/F Selection<br>0: 50 Hz<br>1: 60 Hz Saturation<br>2: 60 Hz Saturation<br>3: 72 Hz<br>4: 50 Hz VT1<br>5: 50 Hz VT2<br>6: 60 Hz VT1<br>7: 60 Hz VT2<br>8: 50 Hz HST1<br>9: 50 Hz HST2<br>A: 60 Hz HST1<br>B: 60 Hz HST2<br>C: 90 Hz<br>D: 120 Hz<br>E: 180 Hz<br>F: Custom V/F | 0: 50 Hz, Constant torque 1<br>1: 60 Hz, Constant torque 2<br>2: 60 Hz, Constant torque 3 (50 Hz base)<br>3: 72 Hz, Constant torque 4 (60 Hz base)<br>4: 50 Hz, Variable torque 1<br>5: 50 Hz, Variable torque 2<br>6: 60 Hz, Variable torque 3<br>7: 60 Hz, Variable torque 4<br>8: 50 Hz, High starting torque 1<br>9: 50 Hz, High starting torque 2<br>A: 60 Hz, High starting torque 3<br>B: 60 Hz, High starting torque 4<br>C: 90 Hz (60 Hz base)<br>D: 120 Hz (60 Hz base)<br>E: 180 Hz (60 Hz base)<br>F: Custom V/f, E1-04 through E1-13 settings define the V/f pattern | Default: F<br>Range: 0 to 9;<br>A to FF  | 155  |

| No. (Addr. Hex)  | Name                              | LCD Display     | Description   | Values  | Page |
|------------------|-----------------------------------|-----------------|---|---|------|
| E1-04 (0303)     | Maximum Output Frequency          | Max Frequency   | <p>These parameters are only applicable when E1-03 is set to F. To set linear V/f characteristics, set the same values for E1-07 and E1-09.</p> <p>In this case, the setting for E1-08 will be disregarded. Ensure that the four frequencies are set according to these rules:<br/> <math>E1-09 \leq E1-07 &lt; E1-06 \leq E1-11 \leq E1-04</math></p>  | Default: 60.0 Hz<br>Min.: 40.0<br>Max.: 400.0       | 158  |
| E1-05 (0304)     | Maximum Voltage                   | Max Voltage     |   | Default: 230 V <1><br>Min.: 0.0<br>Max.: 255.0 <1>  | 158  |
| E1-06 (0305)     | Base Frequency                    | Base Frequency  |   | Default: 60.0 Hz<br>Min.: 0.0<br>Max.: E1-04        | 158  |
| E1-07 (0306)     | Middle Output Frequency           | Mid Frequency A |   | Default: 3.0 Hz<br>Min.: 0.0<br>Max.: E1-04         | 158  |
| E1-08 (0307)     | Middle Output Frequency Voltage   | Mid Voltage A   |   | Default: 18.4 V <1><br>Min.: 0.0<br>Max.: 255.0 <1> | 158  |
| E1-09 (0308)     | Minimum Output Frequency          | Min Frequency   |   | Default: 1.5 Hz<br>Min.: 0.0<br>Max.: E1-04         | 158  |
| E1-10 (0309)     | Minimum Output Frequency Voltage  | Min Voltage     |   | Default: 13.8 V <1><br>Min.: 0.0<br>Max.: 255.0 <1> | 158  |
| E1-11 (030A) <4> | Middle Output Frequency 2         | Mid Frequency B |   | Default: 0.0 Hz<br>Min.: 0.0<br>Max.: E1-04         | 158  |
| E1-12 (030B) <4> | Middle Output Frequency Voltage 2 | Mid Voltage B   |   | Default: 0.0 V<br>Min.: 0.0<br>Max.: 255.0 <1>      | 158  |
| E1-13 (030C)     | Base Voltage                      | Base Voltage    |   | Default: 0.0 V <3><br>Min.: 0.0<br>Max.: 255.0 <1>  | 158  |

- <1> Values shown are specific to 200 V class drives. Double the value for 400 V class drives.
- <2> Parameter setting value is not reset to the default value when the drive is initialized.
- <3> When Auto-Tuning is performed, E1-13 and E1-05 will be set to the same value.
- <4> Parameter ignored when E1-11 (Motor 1 Mid Output Frequency 2) and E1-12 (Motor 1 Mid Output Frequency Voltage 2) are set to 0.0.

## ◆ E2: Motor 1 Parameters

| No. (Addr. Hex) | Name                  | LCD Display      | Description   | Values  | Page |
|-----------------|-----------------------|------------------|---|---|------|
| E2-01 (30E)     | Motor Rated Current   | Motor Rated FLA  | Sets the motor nameplate full load current in amps. Automatically set during Auto-Tuning. | Default: <1><br>Min.: 10% of drive rated current<br>Max.: 200% of drive rated current <2> | 149  |
| E2-02 (030F)    | Motor Rated Slip      | Motor Rated Slip | Sets the motor rated slip. Automatically set during Auto-Tuning.                          | Default: <1><br>Min.: 0.00 Hz<br>Max.: 20.00 Hz   | 159  |
| E2-03 (0310)    | Motor No-Load Current | No-Load Current  | Sets the no-load current for the motor. Automatically set during Auto-Tuning.             | Default: <1><br>Min.: 0 A<br>Max.: E2-01 <2>  | 159  |

## B.6 E: Motor Parameters

| No. (Addr. Hex) | Name                                    | LCD Display     | Description   | Values   | Page                |
|-----------------|---|-----------------|---|--|---------------------|
| E2-04 (0311)    | Number of Motor Poles                   | Number of Poles | Sets the number of motor poles. Automatically set during Auto-Tuning.   | Default: 2<br>Min.: 2<br>Max.: 48                | <a href="#">159</a> |
| E2-05 (0312)    | Motor Line-to-Line Resistance           | Term Resistance | Sets the phase-to-phase motor resistance. Automatically set during Auto-Tuning.   | Default: </><br>Min.: 0.000 Ω<br>Max.: 65.000 Ω  | <a href="#">159</a> |
| E2-06 (0313)    | Motor Leakage Inductance                | Leak Inductance | Sets the voltage drop due to motor leakage inductance as a percentage of motor rated voltage. Automatically set during Auto-Tuning. | Default: </><br>Min.: 0.0%<br>Max.: 40.0%        | <a href="#">160</a> |
| E2-10 (0317)    | Motor Iron Loss for Torque Compensation | Motor Iron Loss | Sets the motor iron loss.   | Default: </><br>Min.: 0 W<br>Max.: 65535 W       | <a href="#">160</a> |
| E2-11 (0318)    | Motor Rated Power                       | Mtr Rated Power | Sets the motor rated power in kilowatts (1 HP = 0.746 kW). Automatically set during Auto-Tuning.                                    | Default: </><br>Min.: 0.00 kW<br>Max.: 650.00 kW | <a href="#">160</a> |

<1> Default setting is dependent on parameter o2-04, Drive Model Selection.

<2> Display is in the following units:

BV0006 to BV0018, 2V0006 to 2V0040, and 4V0002 to 4V0023: 0.01 A units.

2V0056 to 2V0069 and 4V0031 to 4V0038: 0.1 A units.

## B.7 F: Options

### ◆ F6, F7: Communication Option Card

F6 and F7 parameters are used for communication-protocol-specific settings.

| No.<br>(Addr.<br>Hex)  | Name   | LCD Display  | Description  | Values                                   | Page |
|------------------------|--|--|--|--|------|
| F6-01<br>(03A2)        | Communications Error<br>Operation Selection  | Comm Bus Flt Sel<br>0: Ramp to Stop<br>1: Coast to Stop<br>2: Fast-Stop<br>3: Alarm Only           | 0: Ramp to stop. Decelerate to stop using the deceleration time in C1-02.<br>1: Coast to stop.<br>2: Fast Stop. Decelerate to stop using the deceleration time in C1-09.<br>3: Alarm only.               | Default: 1<br>Range: 0 to 3              | 161  |
| F6-02<br>(03A3)        | External Fault from<br>Comm. Option<br>Detection Selection                         | EF0 Detection<br>0: Always Detected<br>1: Only During Run  | 0: Always detected.<br>1: Detection during run only.   | Default: 0<br>Range: 0, 1                | 161  |
| F6-03<br>(03A4)        | External Fault from<br>Comm. Option<br>Operation Selection                         | EF0 Fault Action<br>0: Ramp to Stop<br>1: Coast to Stop<br>2: Fast-Stop<br>3: Alarm Only           | 0: Ramp to stop. Decelerate to stop using the deceleration time in C1-02.<br>1: Coast to stop.<br>2: Fast Stop. Decelerate to stop using the deceleration time in C1-09.<br>3: Alarm only.               | Default: 1<br>Range: 0 to 3              | 161  |
| F6-04<br>(03A5)        | bUS Error Detection<br>Time  | BUS Err Det Time   | Sets the delay time for error detection if a bus error occurs.   | Default: 2.0 s<br>Min.: 0.0<br>Max.: 5.0 | 161  |
| F6-07<br>(03A8)        | Multi-Step Speed<br>Enable/Disable<br>Selection when NefRef/<br>ComRef is Selected | Fref PrioritySel<br>0: Net/Com REF<br>1: MultiStep Speed   | 0: Multi-step reference disabled<br>1: Multi-step reference enabled  | Default: 0<br>Range: 0, 1                | 162  |
| F6-08<br>(036A)<br></> | Reset Communication<br>Parameters  | Com Prm Init Sel<br>0: Init Com Prms<br>1: No Init Com Prms  | 0: Reset all communication-related parameters (F6-□□) when the drive is initialized using A1-03.<br>1: Communication-related parameters (F6-□□) are not reset when the drive is initialized using A1-03. | Default: 0<br>Range: 0, 1                | 162  |
| F6-30<br>(03CB)        | PROFIBUS-DP Node<br>Address  | PB Node Address  | Sets the node address.   | Default: 0<br>Min.: 0<br>Max.: 125       | 162  |
| F6-31<br>(03CC)        | PROFIBUS-DP Clear<br>Mode Selection  | PB Clear Select<br>0: Reset to Zero<br>1: Hold Prev Value  | 0: Resets drive operation with a Clear mode command.<br>1: Maintains the previous operation state when Clear mode command is given.  | Default: 0<br>Range: 0, 1                | 162  |
| F6-32<br>(03CD)        | PROFIBUS-DP Data<br>Format Selection   | PB Map Select<br>0: PPO Type<br>1: Conventional  | 0: PPO Type<br>1: Conventional   | Default: 0<br>Range: 0, 1                | 162  |
| F6-50<br>(03C1)        | DeviceNet MAC<br>Address   | DN MAC Address   | Selects the drive MAC address.   | Default: 64<br>Min.: 0<br>Max.: 64       | 162  |
| F6-51<br>(03C2)        | DeviceNet<br>Communication Speed   | DN Baud Rate<br>0: 125 kbps<br>1: 250 kbps<br>2: 500 kbps<br>3: Set from Network<br>4: Auto Detect | 0: 125 kbps<br>1: 250 kbps<br>2: 500 kbps<br>3: Adjustable from network<br>4: Detect automatically   | Default: 4<br>Range: 0 to 4              | 162  |
| F6-52<br>(03C3)        | DeviceNet PCA Setting  | DN PCA Selection   | Sets the format of the data set from the DeviceNet master to the drive.  | Default: 21<br>Min.: 0<br>Max.: 255      | 162  |
| F6-53<br>(03C4)        | DeviceNet PPA Setting  | DN PPA Selection   | Sets the format of the data set from the drive to the DeviceNet master.  | Default: 71<br>Min.: 0<br>Max.: 255      | 162  |
| F6-54<br>(03C5)        | DeviceNet Idle Mode<br>Fault Detection   | DN Idle Flt Det<br>0: Stop<br>1: Ignore  | 0: Enabled<br>1: Disabled, no fault detection  | Default: 0<br>Range: 0, 1                | 162  |

## B.7 F: Options

| No. (Addr. Hex)               | Name  | LCD Display   | Description  | Values                              | Page                |
|-------------------------------|---|---|--|-------------------------------------|---------------------|
| F6-55 (03C6)                  | DeviceNet Baud Rate Monitor                     | DN BAUD RATE MEM<br>0: 125 kbps<br>1: 250 kbps<br>2: 500 kbps | Verifies the baud rate running on the network.<br>0: 125 kbps<br>1: 250 kbps<br>2: 500 kbps                                | Default: 0<br>Range: 0 to 2         | <a href="#">162</a> |
| F6-56 (03D7)                  | DeviceNet Speed Scaling                         | DN Speed Scale  | Sets the scaling factor for the speed monitor in DeviceNet.  | Default: 0<br>Min.: -15<br>Max.: 15 | <a href="#">162</a> |
| F6-57 (03D8)                  | DeviceNet Current Scaling                       | DN Current Scale  | Sets the scaling factor for the output current monitor in DeviceNet.   | Default: 0<br>Min.: -15<br>Max.: 15 | <a href="#">162</a> |
| F6-58 (03D9)                  | DeviceNet Torque Scaling                        | DN Torque Scale   | Sets the scaling factor for the torque monitor in DeviceNet.   | Default: 0<br>Min.: -15<br>Max.: 15 | <a href="#">162</a> |
| F6-59 (03DA)                  | DeviceNet Power Scaling                         | DN Power Scale  | Sets the scaling factor for the power monitor in DeviceNet.  | Default: 0<br>Min.: -15<br>Max.: 15 | <a href="#">162</a> |
| F6-60 (03DB)                  | DeviceNet Voltage Scaling                       | DN Voltage Scale  | Sets the scaling factor for the voltage monitor in DeviceNet.  | Default: 0<br>Min.: -15<br>Max.: 15 | <a href="#">162</a> |
| F6-61 (03DC)                  | DeviceNet Time Scaling                          | DN Time Scale   | Sets the scaling factor for the time monitor in DeviceNet.   | Default: 0<br>Min.: -15<br>Max.: 15 | <a href="#">162</a> |
| F6-62 (03DD)                  | DeviceNet Heartbeat Interval                    | DN Heart Beat   | Sets the heartbeat interval for DeviceNet communications.  | Default: 0<br>Min.: 0<br>Max.: 10   | <a href="#">162</a> |
| F6-63 (03DE)                  | DeviceNet Network MAC ID                        | DN MAC ID MEM   | Saves and monitors settings 0 to 63 of F6-50 (DeviceNet MAC Address).  | Default: 63<br>Min.: 0<br>Max.: 63  | <a href="#">162</a> |
| F6-64 to F6-71 (03DF to 03C8) | Dynamic I/O Assembly Parameters                 | –   | Dynamic I/O Assembly Parameters  | –                                   | –                   |
| F7-01 to F7-42 (03E5 to 037E) | EtherNet/IP and Modbus TCP/IP Option Parameters | –   | F7 parameters are reserved for use with SI-EN3/V and SI-EM3/V options. Refer to the respective Option Manuals for details. | –                                   | –                   |

<1> Parameter setting value is not reset to the default value when the drive is initialized.

## B.8 H Parameters: Multi-Function Terminals

H parameters assign functions to the multi-function input and output terminals.

**Note:** Cycle power to the drive to enable MEMOBUS/Modbus settings.

### ◆ H1: Multi-Function Digital Inputs

| No. (Addr. Hex)                              | Name  | LCD Display      | Description   | Values  | Page |
|--|---|------------------|---|---|------|
| H1-01 (0438)                                 | Multi-Function Digital Input Terminal S1 Function Selection | Term S1 Func Sel | Assigns a function to the multi-function digital inputs. Refer to pages 336 to 339 for descriptions of setting values.<br><b>Note:</b> Set unused terminals to F. | Default: 40 (F) </><br>Min.: 2<br>Max.: B0    | 163  |
| H1-02 (0439)                                 | Multi-Function Digital Input Terminal S2 Function Selection | Term S2 Func Sel | Assigns a function to the multi-function digital inputs. Refer to pages 336 to 339 for descriptions of setting values.<br><b>Note:</b> Set unused terminals to F. | Default: F<br>Min.: 2<br>Max.: B0             | 163  |
| H1-03 (0400)                                 | Multi-Function Digital Input Terminal S3 Function Selection | Term S3 Func Sel | Assigns a function to the multi-function digital inputs. Refer to pages 336 to 339 for descriptions of setting values.<br><b>Note:</b> Set unused terminals to F. | Default: 26<br>Min.: 0<br>Max.: B0            | 163  |
| H1-04 (0401)                                 | Multi-Function Digital Input Terminal S4 Function Selection | Term S4 Func Sel | Assigns a function to the multi-function digital inputs. Refer to pages 336 to 339 for descriptions of setting values.<br><b>Note:</b> Set unused terminals to F. | Default: 14<br>Min.: 0<br>Max.: B0            | 163  |
| H1-05 (0402)                                 | Multi-Function Digital Input Terminal S5 Function Selection | Term S5 Func Sel | Assigns a function to the multi-function digital inputs. Refer to pages 336 to 339 for descriptions of setting values.<br><b>Note:</b> Set unused terminals to F. | Default: 8D (0) </><br>Min.: 0<br>Max.: B0    | 163  |
| H1-06 (0403)                                 | Multi-Function Digital Input Terminal S6 Function Selection | Term S6 Func Sel | Assigns a function to the multi-function digital inputs. Refer to pages 336 to 339 for descriptions of setting values.<br><b>Note:</b> Set unused terminals to F. | Default: 80 (3) </><br>Min.: 0<br>Max.: B0    | 163  |
| H1-07 (0404)                                 | Multi-Function Digital Input Terminal S7 Function Selection | Term S7 Func Sel | Assigns a function to the multi-function digital inputs. Refer to pages 336 to 339 for descriptions of setting values.<br><b>Note:</b> Set unused terminals to F. | Default: 81 (4) </><br>Min.: 0<br>Max.: B0    | 163  |
| H1-21 (02D7)<br><input type="checkbox"/> RUN | External Fault 1 Delay Time                                 | EF1 Delay Time   | Sets the amount of time delay applied to the EF1 fault. (20 ≤ H1-01 ≤ 2F)   | Default: 0.00 s<br>Min.: 0.00<br>Max.: 300.00 | 167  |
| H1-22 (02D8)<br><input type="checkbox"/> RUN | External Fault 2 Delay Time                                 | EF2 Delay Time   | Sets the amount of time delay applied to the EF2 fault. (20 ≤ H1-02 ≤ 2F)   | Default: 0.00 s<br>Min.: 0.00<br>Max.: 300.00 | 167  |
| H1-23 (02D9)<br><input type="checkbox"/> RUN | External Fault 3 Delay Time                                 | EF3 Delay Time   | Sets the amount of time delay applied to the EF3 fault. (20 ≤ H1-03 ≤ 2F)   | Default: 0.00 s<br>Min.: 0.00<br>Max.: 300.00 | 167  |
| H1-24 (02DA)<br><input type="checkbox"/> RUN | External Fault 4 Delay Time                                 | EF4 Delay Time   | Sets the amount of time delay applied to the EF4 fault. (20 ≤ H1-04 ≤ 2F)   | Default: 0.00 s<br>Min.: 0.00<br>Max.: 300.00 | 167  |
| H1-25 (02DB)<br><input type="checkbox"/> RUN | External Fault 5 Delay Time                                 | EF5 Delay Time   | Sets the amount of time delay applied to the EF5 fault. (20 ≤ H1-05 ≤ 2F)   | Default: 0.00 s<br>Min.: 0.00<br>Max.: 300.00 | 167  |
| H1-26 (02DC)<br><input type="checkbox"/> RUN | External Fault 6 Delay Time                                 | EF6 Delay Time   | Sets the amount of time delay applied to the EF6 fault. (20 ≤ H1-06 ≤ 2F)   | Default: 0.00 s<br>Min.: 0.00<br>Max.: 300.00 | 167  |
| H1-27 (02DD)<br><input type="checkbox"/> RUN | External Fault 7 Delay Time                                 | EF7 Delay Time   | Sets the amount of time delay applied to the EF7 fault. (20 ≤ H1-07 ≤ 2F)   | Default: 0.00 s<br>Min.: 0.00<br>Max.: 300.00 | 167  |

<1> Value in parenthesis is the default setting when a 3-Wire initialization is performed (A1-03 = 3330).

## B.8 H Parameters: Multi-Function Terminals

**Table B.2 H1 Multi-Function Digital Input Selections**

| H1-□□ Setting | Function                         | LCD Display          | Description  | Page                |
|---------------|----------------------------------|----------------------|--|---------------------|
| 0             | 3-Wire sequence                  | 3-Wire Control       | Closed: Reverse rotation (only if the drive is set up for 3-Wire sequence)<br>Terminals S1 and S2 are automatically set up for the Run command and Stop command.   | <a href="#">163</a> |
| 2             | External Reference 1/2 Selection | External Ref 1/2 Sel | Open: Run command and frequency reference source 1 (determined by b1-01 and b1-02)<br>Closed: Run command and frequency reference source 2 (determined by b1-15 and b1-16)   | <a href="#">164</a> |
| 3             | Multi-Step Speed Reference 1     | Multi-Step Ref 1     | When input terminals are set to Multi-Step Speed References 1 through 3, switching combinations of those terminals will create a multi-step speed sequence using the frequency references set in d1-01 through d1-08.  | <a href="#">164</a> |
| 4             | Multi-Step Speed Reference 2     | Multi-Step Ref 2     | When input terminals are set to Multi-Step Speed References 1 through 3, switching combinations of those terminals will create a multi-step speed sequence using the frequency references set in d1-01 through d1-08.  | <a href="#">164</a> |
| 5             | Multi-Step Speed Reference 3     | Multi-Step Ref 3     | When input terminals are set to Multi-Step Speed References 1 through 3, switching combinations of those terminals will create a multi-step speed sequence using the frequency references set in d1-01 through d1-08.  | <a href="#">164</a> |
| 6             | Jog reference selection          | Jog Freq Ref         | Closed: Jog frequency reference (d1-17) selected. Jog has priority over all other reference sources.   | <a href="#">164</a> |
| 7             | Accel/decel time selection 1     | Multi-Acc/Dec 1      | Used to switch between accel/decel time 1 (set in C1-01, C1-02) and accel/decel time 2 (set in C1-03, C1-04).  | <a href="#">164</a> |
| 8             | Baseblock command (N.O.)         | Ext BaseBlk N.O.     | Closed: No drive output  | <a href="#">164</a> |
| 9             | Baseblock command (N.C.)         | Ext BaseBlk N.C.     | Open: No drive output  | <a href="#">164</a> |
| A             | Accel/decel ramp hold            | Acc/Dec RampHold     | Open: Accel/decel is not held<br>Closed: The drive pauses during acceleration or deceleration and maintains the output frequency.  | <a href="#">164</a> |
| B             | Drive overheat alarm (oH2)       | OH2 Alarm Signal     | Closed: An oH2 alarm occurs  | <a href="#">164</a> |
| C             | Analog terminal input selection  | Term A2 Enable       | Open: Function assigned by H3-14 is disabled.<br>Closed: Function assigned by H3-14 is enabled.  | <a href="#">165</a> |
| F             | Through mode                     | Term Not Used        | Select this setting when using the terminal in a pass-through mode. The terminal does not trigger a drive function but can be used as digital input for the controller the drive is connected to.  | <a href="#">165</a> |
| 10            | Up command                       | Up Command 1         | The drive accelerates when the Up command terminal closes, and decelerates when the Down command closes. When both terminals are closed or both are open, the drive holds the frequency reference. The Up and Down commands must always be used in conjunction with one another. | <a href="#">165</a> |
| 11            | Down command                     | Down Command 1       | The drive accelerates when the Up command terminal closes, and decelerates when the Down command closes. When both terminals are closed or both are open, the drive holds the frequency reference. The Up and Down commands must always be used in conjunction with one another. | <a href="#">165</a> |
| 12            | Forward Jog                      | Forward Jog          | Closed: Runs forward at the Jog frequency d1-17.   | <a href="#">166</a> |
| 13            | Reverse Jog                      | Reverse Jog          | Closed: Runs reverse at the Jog frequency d1-17.   | <a href="#">166</a> |
| 14            | Fault reset                      | Fault Reset          | Closed: Resets faults if the cause is cleared and the Run command is removed.  | <a href="#">166</a> |
| 15            | Fast Stop (N.O.)                 | Fast-Stop N.O.       | Closed: Decelerates to stop at the Fast Stop time set to C1-09.  | <a href="#">166</a> |
| 17            | Fast Stop (N.C.)                 | Fast-Stop N.C.       | Open: Decelerates to stop at the Fast Stop time set to C1-09.  | <a href="#">166</a> |
| 18            | Timer function input             | Timer function       | Triggers the timer set up by parameters b4-01 and b4-02. Must be set in conjunction with the timer function output (H2-□□ = 12).   | <a href="#">167</a> |
| 19            | PID disable                      | PID Disable          | Open: PID control enabled<br>Closed: PID control disabled  | <a href="#">167</a> |
| 1B            | Program lockout                  | Program Lockout      | Open: Parameters cannot be edited (except for U1-01 if the reference source is assigned to the digital operator).<br>Closed: Parameters can be edited and saved.   | <a href="#">167</a> |
| 1E            | Reference sample hold            | Ref Sample Hold      | Closed: Samples the analog frequency reference and operates the drive at that speed.   | <a href="#">167</a> |



| H1-□□ Setting | Function                              | LCD Display  | Description  | Page |
|---------------|---------------------------------------|--|--|------|
| 20 to 2F      | External pump fault                   | Ext Pump Fault<br>20: NO/Always Det, Ramp to Stop<br>21: NC/Always Det, Ramp to Stop<br>22: NO/During RUN, Ramp to Stop<br>23: N.C., During run, ramp to stop<br>24: NO/ Always Det, Coast to Stop<br>25: NC/Always Det, Coast to Stop<br>26: NO/During RUN, Coast to Stop<br>27: NC/During RUN, Coast to Stop<br>28: NO/Always Det, Fast-Stop<br>29: NC/Always Det, Fast-Stop<br>2A: NO/During RUN, Fast-Stop<br>2B: NC/During RUN, Fast- Stop<br>2C: NO/Always Det, Alarm Only<br>2D: NC/Always Det, Alarm Only<br>2E: NO/ During RUN, Alarm Only<br>2F: NC/During RUN, Alarm Only | 20: N.O., Always detected, ramp to stop<br>21: N.C., Always detected, ramp to stop<br>22: N.O., During run, ramp to stop<br>23: N.C., During run, ramp to stop<br>24: N.O., Always detected, coast to stop<br>25: N.C., Always detected, coast to stop<br>26: N.O., During run, coast to stop<br>27: N.C., During run, coast to stop<br>28: N.O., Always detected, Fast Stop<br>29: N.C., Always detected, Fast Stop<br>2A: N.O., During run, Fast Stop<br>2B: N.C., During run, Fast Stop<br>2C: N.O., Always detected, alarm only (continue running)<br>2D: N.C., Always detected, alarm only (continue running)<br>2E: N.O., During run, alarm only (continue running)<br>2F: N.C., During run, alarm only (continue running) | 167  |
| 30            | PID integral reset                    | PID Intgrl Reset   | Closed: Resets the PID control integral value.   | 169  |
| 31            | PID integral hold                     | PID Intgrl Hold  | Open: Performs integral operation.<br>Closed: Maintains the current PID control integral value.  | 169  |
| 32            | Multi-Step Speed Reference 4          | Multi-Step Ref 4   | Used in combination with input terminals set to Multi-Step Speed Reference 1, 2, and 3. Use parameters d1-09 to d1-16 to set reference values.   | 169  |
| 34            | PID soft starter cancel               | PID SFS Cancel   | Open: PID soft starter is enabled.<br>Closed: Disables the PID soft starter b5-17.   | 169  |
| 35            | PID input level selection             | PID Input Invert   | Closed: Inverts the PID input signal.  | 169  |
| 40            | Forward run command (2-Wire sequence) | FwdRun 2Wire Seq   | Open: Stop<br>Closed: Forward run<br><b>Note:</b> Cannot be set together with settings 42 or 43.   | 169  |
| 41            | Reverse run command (2-Wire sequence) | RevRun 2WireSeq  | Open: Stop<br>Closed: Reverse run<br><b>Note:</b> Cannot be set together with settings 42 or 43.   | 169  |
| 42            | Run command (2-Wire sequence 2)       | Run/Stp 2WireSeq   | Open: Stop<br>Closed: Run<br><b>Note:</b> Cannot be set together with settings 40 or 41.   | 170  |
| 43            | FWD/REV command (2-Wire sequence 2)   | FWD/REV 2WireSeq   | Open: Forward<br>Closed: Reverse<br><b>Note:</b> Determines motor direction, but does not issue a Run command. Cannot be set together with settings 40 or 41.  | 170  |
| 47            | Node setup                            | CanOpenNID Setup   | Closed: Node setup for SI-S3 enabled.  | 170  |
| 60            | DC Injection Braking command          | DCInj Activate   | Closed: Triggers DC Injection Braking.   | 170  |
| 61            | External Speed Search command 1       | Speed Search 1   | Closed: Activates Current Detection Speed Search from the maximum output frequency (E1-04).  | 170  |
| 62            | External Speed Search command 2       | Speed Search 2   | Closed: Activates Current Detection Speed Search from the frequency reference.   | 170  |
| 65            | KEB Ride-Thru 1 (N.C.)                | KEB Ridethru NC  | Open: KEB Ride-Thru 1 enabled.   | 170  |

## B.8 H Parameters: Multi-Function Terminals

| H1-□□ Setting | Function                          | LCD Display      | Description   | Page |
|---------------|-----------------------------------|------------------|---|------|
| 66            | KEB Ride-Thru 1 (N.O.)            | KEB Ridethru NO  | Closed: KEB Ride-Thru 1 enabled.  | 170  |
| 67            | Communications test mode          | Comm Test Mode   | Tests the MEMOBUS/Modbus RS-422/RS-485 interface. Displays “PASS” if the test completes successfully.   | 170  |
| 6A            | Drive enable                      | Drive Enable     | Open: Drive disabled. If this input is opened during run, the drive will stop as specified by b1-03.<br>Closed: Ready for operation.  | 171  |
| 73            | Low City Press                    | Low City Press   | Indicates that sufficient or insufficient pressure is present on the inlet to the pump. Used mainly for pressure booster situations.<br><b>Note:</b> 1. Parameter P4-21 determines if this input is normally open or normally closed.<br>2. When P1-01 = 3, an alarm condition will cause drives in the network to stop running and show a “Net Pump Err” message.  | 171  |
| 75            | Up 2 command                      | Up Command 2     | Controls the bias added to the frequency reference by the Up/Down 2 function. The Up 2 and Down 2 commands must always be used in conjunction with one another.   | 171  |
| 76            | Down 2 command                    | Down Command 2   | Controls the bias added to the frequency reference by the Up/Down 2 function. The Up 2 and Down 2 commands must always be used in conjunction with one another.   | 171  |
| 7A            | KEB Ride-Thru 2 (N.C.)            | KEB Ridethru2NC  | Open: KEB Ride-Thru 2 enabled.  | 172  |
| 7B            | KEB Ride-Thru 2 (N.O.)            | KEB Ridethru2NO  | Closed: KEB Ride-Thru 2 enabled.  | 172  |
| 80            | HAND Mode                         | Hand Mode        | Closed: HAND Mode operation. Frequency reference determined by P5-01 and P5-02.<br>Open: Stop Mode when no Run command.   | 172  |
| 81            | HAND Mode 2                       | Hand Mode 2      | Closed: HAND Mode operation. Frequency reference determined by P5-05.<br>Open: Stop Mode when no Run command.   | 172  |
| 83            | Alternate Multi Setpoint (Q1-02)  | AltMultiSP Q1-02 | Closed: Q1-02 becomes the PID setpoint  | 172  |
| 84            | Alternate Multi Setpoint (Q1-03)  | AltMultiSP Q1-03 | Closed: Q1-03 becomes the PID setpoint  | 172  |
| 85            | Alternate Multi Setpoint (Q1-04)  | AltMultiSP Q1-04 | Closed: Q1-04 becomes the PID setpoint  | 172  |
| 88            | Volute-Thermostat Normally Open   | Volute-TStat NO  | Function active when the drive is running.<br>Closed: Drive will trip on “VLTS - Volute-TStat Flt”<br>Open: Thermostat fault not active<br><b>Note:</b> Setting H1-□□ = 88 and 89 simultaneously will trigger a “VLTS - Volute-TStat Flt”.  | 172  |
| 89            | Volute-Thermostat Normally Closed | Volute-TStat NC  | Function active when the drive is running.<br>Closed: Thermostat fault not active<br>Open: Drive will trip on “VLTS - Volute-TStat Flt”<br><b>Note:</b> Setting H1-□□ = 88 and 89 simultaneously will trigger a “VLTS - Volute-TStat Flt”.  | 172  |
| 8C            | Disable Pre-Charge                | Disable Pre-Chrg | Closed: Pre-Charge disabled.  | 173  |
| 8D            | Multi Setpoint 1                  | Multi Setpoint 1 | Open: Frequency reference, Q1-01, or Q1-03 is PID Setpoint.<br>Closed: Q1-02 or Q1-04 is PID Setpoint.  | 173  |
| 8E            | Multi Setpoint 2                  | Multi Setpoint 2 | Open: Frequency reference, Q1-01, or Q1-02 is PID Setpoint.<br>Closed: Q1-03 or Q1-04 is PID Setpoint.  | 173  |
| 8F            | Low Water Level                   | Low Water        | Function active in AUTO Mode during normal operation, also used with Pre-Charge function. Function logic depends on P1-30, Low Water Digital Input Configuration.<br>P1-30 = 0 (Normally open)<br>Closed: Low water level fault<br>Open: Reservoir/Tank is filled to normal level<br>P1-30 = 1 (Normally closed)<br>Closed: Reservoir/Tank is filled to normal level<br>Open: Low water level fault<br>Pre-Charge function: Function uses the low water level input as “Tank/Reservoir” feedback to indicate that the water level has been reached. | 173  |

| H1-□□ Setting | Function                       | LCD Display      | Description  | Page |
|---------------|--------------------------------|------------------|--|------|
| 90            | High Water Level               | High Water       | Function active when the drive is running. Function logic depends on P1-31, High Water Digital Input Configuration.<br>P1-31 = 0 (Normally open)<br>Closed: High water level fault<br>Open: Reservoir/Tank is filled to normal level<br>P1-31 = 1 (Normally closed)<br>Closed: Reservoir/Tank is filled to normal level<br>Open: High water level fault          | 173  |
| 95            | Remove Drive Disable           | Remote Drv Disbl | Closed: Prevents the drive from running when active for the time set in P4-26. Must be inactive for the time set in P4-27 to allow the drive to run again.<br><br><b>Note:</b> 1. Parameter P4-25 determines if this input is normally open or normally closed.<br>2. When P1-01 = 3, an alarm condition will cause this drive to be unavailable to the network. | 173  |
| AF            | Emergency Override Forward Run | EmergOverrideFWD | Closed: Run the drive forward using the speed set in S6-02.  | 173  |
| B0            | Emergency Override Reverse Run | EmergOverrideREV | Closed: Run the drive in reverse using the speed set in S6-02.   | 173  |

◆ H2: Multi-Function Digital Outputs

| No. (Addr. Hex) | Name   | LCD Display      | Description   | Values                         | Page |
|-----------------|--|------------------|---|--------------------------------|------|
| H2-01 (040B)    | Terminal MA, MB, and MC function selection (relay) | MA/MB/MC FuncSel | Refer to H2 Multi-Function Digital Output Settings on pages 339 to 341 for descriptions of setting values.  | Default: E<br>Range: 0 to 1AA  | 174  |
| H2-02 (040C)    | Terminal P1 function selection (open-collector)    | P1/PC Func Sel   |   | Default: 37<br>Range: 0 to 1AA | 174  |
| H2-03 (040D)    | Terminal P2 function selection (open-collector)    | P2/PC Func Sel   |   | Default: E<br>Range: 0 to 1AA  | 174  |
| H2-06 (0437)    | Watt Hour Output Unit Selection                    | Pwr Mon Unit Sel | Outputs a 200 ms pulse signal when the watt-hour counter increases by the units selected.<br>0: 0.1 kWh units<br>1: 1 kWh units<br>2: 10 kWh units<br>3: 100 kWh units<br>4: 1000 kWh units | Default: 0<br>Range: 0 to 4    | 182  |

Table B.3 H2 Multi-Function Digital Output Settings

| H2-□□ Setting | Function                | LCD Display      | Description  | Page |
|---------------|-------------------------|------------------|--|------|
| 0             | During run              | During RUN 1     | Closed: A Run command is active or voltage is output.  | 174  |
| 1             | Zero speed              | Zero Speed       | Open: Output frequency is above the minimum output frequency set in E1-09.<br>Closed: Output frequency is below the minimum output frequency set in E1-09. | 174  |
| 2             | Speed agree 1           | Fref/Fout Agree1 | Closed: Output frequency equals the speed reference (plus or minus the hysteresis set to L4-02).   | 174  |
| 3             | User-set speed agree 1  | Fref/Set Agree 1 | Closed: Output frequency and speed reference equal L4-01 (plus or minus the hysteresis set to L4-02).  | 175  |
| 4             | Frequency detection 1   | Freq Detect 1    | Closed: Output frequency is less than or equal to the value in L4-01 with hysteresis determined by L4-02.  | 175  |
| 5             | Frequency detection 2   | Freq Detect 2    | Closed: Output frequency is greater than or equal to the value in L4-01 with hysteresis determined by L4-02.   | 176  |
| 6             | Drive ready             | Drive Ready      | Closed: Power up is complete and the drive is ready to accept a Run command.   | 176  |
| 7             | DC bus undervoltage     | DC Bus Undervolt | Closed: DC bus voltage is below the Uv trip level set in L2-05.  | 176  |
| 8             | During baseblock (N.O.) | BaseBlk 1        | Closed: Drive has entered the baseblock state (no output voltage).   | 176  |

## B.8 H Parameters: Multi-Function Terminals

| H2-□□ Setting | Function                       | LCD Display      | Description  | Page |
|---------------|--------------------------------|------------------|--|------|
| 9             | Frequency reference source     | Ref Source       | Open: External Reference 1 or 2 supplies the frequency reference (set in b1-01 or b1-15).<br>Closed: Digital operator supplies the frequency reference.  | 177  |
| A             | HAND mode                      | Hand Mode        | Open: External Reference 1 or 2 supplies the Run command (set in b1-02 or b1-16).<br>Closed: Pump is in HAND Mode operation.   | 177  |
| B             | Torque detection 1 (N.O.)      | Trq Det 1 N.O.   | Closed: An overtorque or undertorque situation has been detected.  | 177  |
| C             | Frequency reference loss       | Loss of Ref      | Closed: Analog frequency reference has been lost.<br>Frequency reference loss is detected when the frequency reference drops below 10% of the reference within 400 ms.   | 177  |
| D             | Braking resistor fault         | DB Overheat      | Closed: Braking resistor or transistor is overheated or faulted out.   | 177  |
| E             | Fault                          | Fault            | Closed: Fault occurred.  | 177  |
| F             | Through mode                   | Not Used         | Set this value when using the terminal in the pass-through mode.   | 177  |
| 10            | Minor fault                    | Minor Fault      | Closed: An alarm has been triggered, or the IGBTs have reached 90% of their expected life span.  | 177  |
| 11            | Fault reset command active     | Reset Cmd Active | Closed: A command has been entered to clear a fault via the input terminals or from the serial network.  | 177  |
| 12            | Timer output                   | Timer Output     | Closed: Timer output.  | 177  |
| 13            | Speed agree 2                  | Fref/Fout Agree2 | Closed: When drive output frequency equals the frequency reference $\pm$ L4-04.  | 178  |
| 14            | User-set speed agree 2         | Fref/Set Agree 2 | Closed: When the drive output frequency is equal to the value in L4-03 $\pm$ L4-04.  | 178  |
| 15            | Frequency detection 3          | Freq Detect 3    | Closed: When the drive output frequency is less than or equal to the value in L4-03 $\pm$ L4-04.   | 178  |
| 16            | Frequency detection 4          | Freq Detect 4    | Closed: When the output frequency is greater than or equal to the value in L4-03 $\pm$ L4-04.  | 179  |
| 17            | Torque detection 1 (N.C.)      | Trq Det 1 N.C.   | Open: Overtorque or undertorque has been detected.   | 177  |
| 18            | Torque detection 2 (N.O.)      | Trq Det 2 N.O.   | Closed: Overtorque or undertorque has been detected.   |      |
| 19            | Torque detection 2 (N.C.)      | Trq Det 2 N.C.   | Open: Overtorque or undertorque has been detected.   | 177  |
| 1A            | During reverse                 | Reverse Dir      | Closed: Drive is running in the reverse direction.   | 179  |
| 1B            | During baseblock (N.C.)        | BaseBlk 2        | Open: Drive has entered the baseblock state (no output voltage).   | 180  |
| 1E            | Restart enabled                | Dur Flt Restart  | Closed: Automatic restart is performed   | 180  |
| 1F            | Motor overload alarm (oL1)     | Overload (OL1)   | Closed: oL1 is at 90% of its trip point or greater. An oH3 situation also triggers this alarm.   | 180  |
| 20            | Drive overheat pre-alarm (oH)  | OH Prealarm      | Closed: Heatsink temperature exceeds the parameter L8-02 value.  | 180  |
| 22            | Mechanical weakening detection | MechFatigue(OL5) | Closed: Mechanical weakening detected.   | 180  |
| 2F            | Maintenance period             | Maintenance      | Closed: Cooling fan, electrolytic capacitors, IGBTs, or the soft charge bypass relay may require maintenance.  | 180  |
| 37            | During frequency output        | During RUN 2     | Open: Either the drive has stopped or baseblock, DC Injection Braking, or Initial Excitation is being performed.<br>Closed: Drive is running the motor (not in a baseblock state and DC Injection is not being performed). | 180  |
| 38            | Drive enabled                  | Drive Enable     | Closed: Multi-function input set for "Drive enable" is closed (H1-□□ = 6A)   | 180  |
| 39            | Watt hour pulse output         | Watt-hour Pulse  | Output units are determined by H2-06. Outputs a pulse every 200 ms to indicate the kWh count.  | 180  |
| 3D            | During speed search            | During SpdSrch   | Closed: Speed Search is being executed.  | 181  |
| 3E            | PID feedback low               | PID Feedback Low | Closed: PID feedback level is too low.   | 181  |
| 3F            | PID feedback high              | PID FeedbackHigh | Closed: The PID feedback level is too high.  | 181  |
| 4A            | During KEB Ride-Thru           | During KEB       | Closed: KEB Ride-Thru is being performed.  | 181  |
| 4C            | During fast stop               | During Fast Stop | Closed: A Fast Stop command has been entered from the operator or input terminals.   | 181  |
| 4D            | oH Pre-alarm time limit        | OH Pre-Alarm     | Closed: oH pre-alarm time limit has passed.  | 181  |

| H2-□□ Setting | Function                             | LCD Display                      | Description   | Page |
|---------------|--------------------------------------|----------------------------------|---|------|
| 4E            | Braking transistor fault (rr)        | Brk Trans Fault                  | Closed: The built-in dynamic braking transistor failed.   | 181  |
| 4F            | Braking resistor overheat (oH)       | BrkResistOvHeat                  | Closed: The dynamic braking resistor has overheated.  | 181  |
| 58            | Underload detection                  | UL6                              | Closed: Underload is detected.  | 181  |
| 89            | Output I Limit                       | Output I Lim                     | Closed: Drive output speed is being limited due to the output current limit or the single phase foldback regulator.   | 181  |
| 8B            | Lube Pump or Digital Output Delay    | Lube Pump or DigitalOutput Delay | Closed: Refer to Lube Pump / Digital Output Delay parameters P4-30 and P4-31. Display text is set by parameter P4-29.   | 181  |
| 8F            | Internal Fan On                      | Internal Fan On                  | Internal Fan On   | 181  |
| 91            | Pump Fault                           | Pump Fault                       | Closed when any of the following faults are active: <ul style="list-style-type: none"> <li>• Low feedback</li> <li>• High feedback</li> <li>• Low water</li> <li>• High water</li> <li>• NMS-Setpoint not met</li> <li>• POC-Pump over cycle</li> <li>• THMS-Thermostat input</li> <li>• External pump fault</li> </ul> | 181  |
| 92            | Transducer Loss                      | Transducer Loss                  | Closed: The analog output associated with PID feedback has risen above 21 mA or fallen below 3 mA or a Transducer Loss alarm or fault is active.  | 181  |
| 93            | Setpoint Not Met                     | SetPoint Not Met                 | Closed: During an “NMS-Setpoint Not Met” condition.   | 181  |
| 94            | Loss of Prime                        | Loss of Prime                    | Closed: During an “LOP-Loss of Prime” condition.  | 181  |
| 95            | Volute Thermostat Fault              | Volute-TStat Flt                 | Closed: Volute-Thermostat digital input is active.  | 181  |
| 96            | High Feedback                        | High Feedback                    | Closed: During a “High Feedback” condition as defined by P1-11 and P1-14 OR<br>Closed: During a “High FB/Water” fault OR<br>Closed: During a “High Feedback” alarm  | 182  |
| 97            | Low Feedback                         | Low Feedback                     | Closed: During a “Low Feedback” condition as defined by P1-08 and P1-14 OR<br>Closed: During a “Low FB/Water” fault OR<br>Closed: During a “Low Feedback” alarm   | 182  |
| A2            | Sleep Active                         | Sleep Active                     | Closed: The drive is not running due to the Sleep function (does not include Sleep Boost).  | 182  |
| A3            | Start Delay                          | Start Delay                      | Closed: Feedback has risen above the start level (or fallen below for Inverse PID) and the start timer is timing.   | 182  |
| A4            | Pre-Charge                           | Pre-Chg Active                   | Closed: Drive is in Pre-Charge mode.  | 182  |
| A5            | Anti-Jam Active                      | Anti-Jam Active                  | Closed: The anti-jam function is active (configured by P7-□□).  | 182  |
| A9            | Thrust Mode                          | Thrust Mode                      | Closed: The Thrust Bearing feature is active (output frequency is between 0 and the value of P4-12).  | 182  |
| AA            | Utility Start Delay                  | Utility Delay                    | Closed: The drive is stopped and waiting for the utility delay timer set in P4-17 to expire.  | 182  |
| 100 to 1AA    | Function 0 to AA with inverse output | –                                | Inverts the output switching of the multi-function output functions. Set the last two digits of 1□□ to reverse the output signal of that specific function.   | 182  |

◆ H3: Multi-Function Analog Inputs

| No. (Addr. Hex)       | Name                               | LCD Display  | Description  | Values   | Page |
|-----------------------|------------------------------------|--|--|--|------|
| H3-01 (0410)          | Terminal A1 Signal Level Selection | Term A1 Level<br>0: 0-10V,<br>(LowLim=0)<br>1: 0-10V, (BipolRef) | 0: 0 to 10 V<br>1: -10 to 10 V   | Default: 0<br>Range: 0, 1                      | 182  |
| H3-02 (0434)          | Terminal A1 Function Selection     | Term A1 FuncSel  | Sets the function of terminal A1.  | Default: 0<br>Range: 0 to 41                   | 183  |
| H3-03 (0411)<br>[RUN] | Terminal A1 Gain Setting           | Terminal A1 Gain   | Sets the level of the input value selected in H3-02 when 10 V is input at terminal A1. | Default: 100.0%<br>Min.: -999.9<br>Max.: 999.9 | 183  |

## B.8 H Parameters: Multi-Function Terminals

| No. (Addr. Hex)       | Name                                   | LCD Display  | Description   | Values   | Page                |
|-----------------------|--|--|---|--|---------------------|
| H3-04 (0412)<br>[RUN] | Terminal A1 Bias Setting               | Terminal A1 Bias   | Sets the level of the input value selected in H3-02 when 0 V is input at terminal A1.   | Default: 0.0%<br>Min.: -999.9<br>Max.: 999.9   | <a href="#">183</a> |
| H3-09 (0417)          | Terminal A2 Signal Level Selection     | Term A2 Level<br>0: 0-10V,<br>(LowLim=0)<br>1: 0-10V, (BipolRef)<br>2: 4-20 mA<br>3: 0-20 mA | 0: 0 to 10 V<br>1: -10 to 10 V<br>2: 4 to 20 mA<br>3: 0 to 20 mA<br><b>Note:</b> Use DIP Switch S1-2 to set input terminal A2 for a current or voltage input signal.  | Default: 2<br>Range: 0 to 3                    | <a href="#">184</a> |
| H3-10 (0418)          | Terminal A2 Function Selection         | Term A2 FuncSel  | Sets the function of terminal A2.   | Default: B<br>Range: 0 to 41                   | <a href="#">184</a> |
| H3-11 (0419)<br>[RUN] | Terminal A2 Gain Setting               | Terminal A2 Gain   | Sets the level of the input value selected in H3-10 when 10 V (20 mA) is input at terminal A2.  | Default: 100.0%<br>Min.: -999.9<br>Max.: 999.9 | <a href="#">184</a> |
| H3-12 (041A)<br>[RUN] | Terminal A2 Bias Setting               | Terminal A2 Bias   | Sets the level of the input value selected in H3-10 when 0 V (0 or 4 mA) is input at terminal A2.   | Default: 0.0%<br>Min.: -999.9<br>Max.: 999.9   | <a href="#">184</a> |
| H3-13 (041B)          | Analog Input Filter Time Constant      | A1/A2 Filter T   | Sets a primary delay filter time constant for terminals A1 and A2. Used for noise filtering.  | Default: 0.03 s<br>Min.: 0.00<br>Max.: 2.00    | <a href="#">184</a> |
| H3-14 (041C)          | Analog Input Terminal Enable Selection | A1/A2 Sel<br>1: A1 Available<br>2: A2 Available<br>7: All Available                          | Determines which analog input terminals will be enabled when a digital input programmed for "Analog input enable" (H1-□□ = C) is activated.<br>1: Terminal A1 only<br>2: Terminal A2 only<br>7: All terminals enabled | Default: 7<br>Range: 1, 2, 7                   | <a href="#">186</a> |
| H3-16 (0440)          | Terminal A1 Offset                     | Term A1 Offset   | Adds an offset when the analog signal to terminal A1 is at 0 V.   | Default: 0<br>Min.: -500<br>Max.: 500          | <a href="#">185</a> |
| H3-17 (0441)          | Terminal A2 Offset                     | Term A2 Offset   | Adds an offset when the analog signal to terminal A2 is at 0 V.   | Default: 0<br>Min.: -500<br>Max.: 500          | <a href="#">185</a> |

### H3 Multi-Function Analog Input Settings

| H3-□□ Setting | Function                               | LCD Display      | Description   | Page                |
|---------------|--|------------------|---|---------------------|
| 0             | Frequency bias                         | Freq Ref Bias    | 10 V = E1-04 (maximum output frequency)   | <a href="#">185</a> |
| 1             | Frequency gain                         | Freq Ref Gain    | 0 to 10 V signal allows a setting of 0 to 100%. -10 to 0 V signal allows a setting of -100 to 0%.   | <a href="#">185</a> |
| 2             | Auxiliary frequency reference 1        | Aux Reference1   | 10 V = E1-04 (maximum output frequency)   | <a href="#">185</a> |
| 4             | Output voltage bias                    | Voltage Bias     | 10 V = E1-05 (motor rated voltage)  | <a href="#">185</a> |
| 7             | Overtorque/undertorque detection level | Torque Det Level | 10 V = Drive rated current (V/f)  | <a href="#">185</a> |
| B             | PID feedback                           | PID Feedback1    | 10 V = 100%   | <a href="#">185</a> |
| C             | PID setpoint                           | PID Set Point    | 10 V = 100%   | <a href="#">185</a> |
| E             | Motor Temperature (PTC Input)          | E Motor PTC      | 10 V = 100%   | <a href="#">185</a> |
| F             | Through mode                           | Not Used         | Select this setting when using the terminal in a pass-through mode. The terminal does not trigger a drive function but can be used as digital input for the controller the drive is connected to. | <a href="#">185</a> |
| 16            | Differential PID feedback              | PID Feedback 2   | 10 V = 100%   | <a href="#">185</a> |
| 1F            | Through mode                           | Not Used         | Set this value when using the terminal in the pass-through mode.  | <a href="#">185</a> |
| 20            | HAND Frequency Reference               | Hand Freq. Ref.  | Full scale: Max. frequency (E1-04)  | <a href="#">185</a> |
| 41            | Output Voltage Gain                    | V/f out gain     | 10 V = 100%   | <a href="#">185</a> |

◆ H4: Analog Outputs

| No. (Addr. Hex)       | Name   | LCD Display      | Description   | Values   | Page |
|-----------------------|--|------------------|---|--|------|
| H4-01 (041D)          | Multi-Function Analog Output Terminal AM Monitor Selection | Term AM FuncSel  | Selects the data to be output through multi-function analog output terminal AM.<br>Set the desired monitor parameter to the digits available in U□-□□.<br>For example, enter “103” for U1-03. | Default: 102<br>Range: 000 to 999              | 186  |
| H4-02 (041E)<br>[RUN] | Multi-Function Analog Output Terminal AM Gain              | Terminal AM Gain | Sets the signal level at terminal AM that is equal to 100% of the selected monitor value.   | Default: 100.0%<br>Min.: -999.9<br>Max.: 999.9 | 186  |
| H4-03 (041F)<br>[RUN] | Multi-Function Analog Output Terminal AM Bias              | Terminal AM Bias | Sets the signal level at terminal AM that is equal to 0% of the selected monitor value.   | Default: 0.0%<br>Min.: -999.9<br>Max.: 999.9   | 186  |

◆ H5: MEMOBUS/Modbus Serial Communication

| No. (Addr. Hex)     | Name   | LCD Display   | Description  | Values                                       | Page |
|---------------------|--|---|--|--|------|
| H5-01 (0425)<br></> | Drive Node Address                               | Serial Comm Adr   | Selects drive station node number (address) for MEMOBUS/Modbus terminals R+, R-, S+, S-. Cycle power for the setting to take effect.   | Default: 1F (Hex)<br>Min.: 0<br>Max.: FF <=> | 391  |
| H5-02 (0426)        | Communication Speed Selection                    | Serial Baud Rate<br>0: 1200 bps<br>1: 2400 bps<br>2: 4800 bps<br>3: 9600 bps<br>4: 19.2 kbps<br>5: 38.4 kbps<br>6: 57.6 kbps<br>7: 76.8 kbps<br>8: 115.2 kbps | 0: 1200 bps<br>1: 2400 bps<br>2: 4800 bps<br>3: 9600 bps<br>4: 19200 bps<br>5: 38400 bps<br>6: 57600 bps<br>7: 76800 bps<br>8: 115200 bps<br>Cycle power for the setting to take effect. | Default: 3<br>Range: 0 to 8                  | 391  |
| H5-03 (0427)        | Communication Parity Selection                   | Serial Com Sel<br>0: No parity<br>1: Even parity<br>2: Odd parity   | 0: No parity<br>1: Even parity<br>2: Odd parity<br>Cycle power for the setting to take effect.   | Default: 0<br>Range: 0 to 2                  | 391  |
| H5-04 (0428)        | Stopping Method after Communication Error (CE)   | Serial Fault Sel<br>0: Ramp to Stop<br>1: Coast to Stop<br>2: Fast-Stop<br>3: Alarm Only  | 0: Ramp to stop<br>1: Coast to stop<br>2: Fast Stop<br>3: Alarm only   | Default: 3<br>Range: 0 to 3                  | 392  |
| H5-05 (0429)        | Communication Fault Detection Selection          | Serial Flt Dtct<br>0: Disabled<br>1: Enabled  | 0: Disabled<br>1: Enabled. If communication is lost for more than two seconds, a CE fault will occur.  | Default: 1<br>Range: 0, 1                    | 392  |
| H5-06 (042A)        | Drive Transmit Wait Time                         | Transmit WaitTIM  | Set the wait time between receiving and sending data.  | Default: 5 ms<br>Min.: 5<br>Max.: 65         | 392  |
| H5-07 (042B)        | RTS Control Selection                            | RTS Control Sel<br>0: Disabled<br>1: Enabled  | 0: Disabled. RTS is always on.<br>1: Enabled. RTS turns on only when sending.  | Default: 1<br>Range: 0, 1                    | 392  |
| H5-09 (0435)        | CE Detection Time                                | CE Detect Time  | Sets the time required to detect a communications error. Adjustment may be needed when networking several drives.  | Default: 2.0 s<br>Min.: 0.0<br>Max.: 10.0    | 392  |
| H5-10 (0436)        | Unit Selection for MEMOBUS/Modbus Register 0025H | CommReg 25h Unit<br>0: 0.1 V<br>1: 1 V  | 0: 0.1 V units<br>1: 1 V units   | Default: 0<br>Range: 0, 1                    | 393  |
| H5-11 (043C)        | Communications ENTER Function Selection          | Enter CommandSel<br>0: Enter Required<br>1: No EnterRequired  | 0: Drive requires an Enter command before accepting any changes to parameter settings.<br>1: Parameter changes are activated immediately without the Enter command.                      | Default: 0<br>Range: 0, 1                    | 394  |

## B.8 H Parameters: Multi-Function Terminals

| No. (Addr. Hex) | Name                         | LCD Display   | Description                                   | Values                    | Page                |
|-----------------|------------------------------|---|---|---------------------------|---------------------|
| H5-12 (043D)    | Run Command Method Selection | Run CommandSel<br>0: FWD Run &REV Run<br>1: Run & FWD/REV | 0: FWD/Stop, REV/Stop<br>1: Run/Stop, FWD/REV | Default: 0<br>Range: 0, 1 | <a href="#">394</a> |

<1> If this parameter is set to 0, the drive will be unable to respond to MEMOBUS/Modbus commands.

<2> When P1-01, Pump Mode, is set to 3 (MEMOBUS network), the range is dependent on P9-25, Highest Node Address.

### ◆ H6: Pulse Train Input

| No. (Addr. Hex)                              | Name   | LCD Display   | Description  | Values   | Page                |
|--|--|---|--|--|---------------------|
| H6-01 (042C)                                 | Pulse Train Input Terminal RP Function Selection | Term RP Func Sel<br>0: Frequency Ref<br>1: PID Feedback<br>2: PID Set Point | 0: Frequency reference<br>1: PID feedback value<br>2: PID setpoint value   | Default: 0<br>Range: 0 to 2                            | <a href="#">187</a> |
| H6-02 (042D)<br><input type="checkbox"/> RUN | Pulse Train Input Scaling                        | Term RP Scaling   | Sets the terminal RP input signal frequency that is equal to 100% of the value selected in H6-01.  | Default: 1440 Hz<br>Min.: 100<br>Max.: 32000           | <a href="#">187</a> |
| H6-03 (042E)<br><input type="checkbox"/> RUN | Pulse Train Input Gain                           | Term RP Gain  | Sets the level of the value selected in H6-01 when a frequency with the value set in H6-02 is input.   | Default: 100.0%<br>Min.: 0.0<br>Max.: 1000.0           | <a href="#">187</a> |
| H6-04 (042F)<br><input type="checkbox"/> RUN | Pulse Train Input Bias                           | Term RP Bias  | Sets the level of the value selected in H6-01 when 0 Hz is input.  | Default: 0.0%<br>Min.: -100.0<br>Max.: 100.0           | <a href="#">188</a> |
| H6-05 (0430)<br><input type="checkbox"/> RUN | Pulse Train Input Filter Time                    | Term RP Flt Time  | Sets the pulse train input filter time constant.   | Default: 0.50 s<br>Min.: 0.00<br>Max.: 2.00            | <a href="#">188</a> |
| H6-06 (0431)<br><input type="checkbox"/> RUN | Pulse Train Monitor Terminal MP Selection        | Term MP Func Sel  | Select the pulse train monitor output function (value of the □-□□ part of U□-□□).<br><b>Refer to U: Monitors on page 369</b> for the list of U monitors.<br>Example: Select “501” for monitor U5-01. Select “0” when not using this parameter or when using in the through mode. <I> | Default: 102<br>Range: 0, 31, 101, 102, 116, 501, 502, | <a href="#">188</a> |
| H6-07 (0432)<br><input type="checkbox"/> RUN | Pulse Train Monitor Scaling                      | Term MP Scaling   | Sets the terminal MP output signal frequency when the monitor value is 100%.<br>Set H6-06 to 102 and H6-07 to 0 to make the pulse train monitor output equal to the output frequency.  | Default: 1440 Hz<br>Min.: 0<br>Max.: 32000             | <a href="#">188</a> |
| H6-08 (043F)                                 | Pulse Train Input Minimum Frequency              | RP Lower Limit  | Sets the minimum frequency for the pulse train input to be detected. Enabled when H6-01 = 0, 1, or 2.  | Default: 0.5 Hz<br>Min.: 0.1<br>Max.: 1000.0           | <a href="#">188</a> |

<1> When set for sourcing, +5 V/1.5 kΩ or higher, +8 V/3.5 kΩ or higher, +10 V/10 kΩ or higher. When set for sinking, the external power supply should be +12 Vdc, ±5% with 16 mA or less.



## B.9 L: Protection Function

L parameters provide protection to the drive and motor.

### ◆ L1: Motor Protection

| No. (Addr. Hex)   | Name   | LCD Display  | Description  | Values                                       | Page |
|---|--|--|--|--|------|
| L1-01 (0480)  | Motor Overload Protection Selection                  | Mtr OL Charact<br>0: OL1 Disabled<br>1: VT Motor<br>2: CT Motor<br>3: Vector Motor<br>6: 50Hz VT Motor | 0: Disabled<br>1: General purpose motor (standard fan cooled)<br>2: Drive dedicated motor with a speed range of 1:10<br>3: Vector motor with a speed range of 1:100<br>6: General purpose motor (50 Hz)<br>The drive may not be able to provide protection when using multiple motors, even if overload is enabled in L1-01. Set L1-01 to 0 and install separate thermal relays to each motor. | Default: 1<br>Range: 0 to 3; 6               | 189  |
| L1-02 (0481)  | Motor Overload Protection Time                       | MOL Time Const   | Sets the motor thermal overload protection (oL1) time.   | Default: 1.0 min<br>Min.: 0.1<br>Max.: 5.0   | 190  |
| L1-03 (0482)  | Motor Overheat Alarm Operation Selection (PTC input) | Mtr OH Alarm Sel<br>0 : Ramp to Stop<br>1: Coast to Stop<br>2: Fast-Stop<br>3: Alarm only              | Sets operation when the motor temperature analog input (H3-02 or H3-10 = E) exceeds the oH3 alarm level.<br>0: Ramp to stop<br>1: Coast to stop<br>2: Fast Stop (decelerate to stop using the deceleration time in C1-09)<br>3: Alarm only (“oH3” will flash)  | Default: 3<br>Range: 0 to 3                  | 192  |
| L1-04 (0483)  | Motor Overheat Fault Operation Selection (PTC input) | Mtr OH Fault Sel<br>0 : Ramp to Stop<br>1: Coast to Stop<br>2: Fast-Stop                               | Sets stopping method when the motor temperature analog input (H3-02 or H3-10 = E) exceeds the oH4 fault level.<br>0: Ramp to stop<br>1: Coast to stop<br>2: Fast Stop (decelerate to stop using the deceleration time in C1-09)  | Default: 1<br>Range: 0 to 2                  | 193  |
| L1-05 (0484)  | Motor Temperature Input Filter Time (PTC input)      | Mtr Temp Filter  | Adjusts the filter for the motor temperature analog input (H3-02 or H3-10 = E).  | Default: 0.20 s<br>Min.: 0.00<br>Max.: 10.00 | 193  |
| L1-13 (046D)  | Continuous Electrothermal Operation Selection        | Mtr OL Mem Sel<br>0: Disabled<br>1: Enabled<br>2: Enabled(RTC)   | 0: Disabled<br>1: Enabled<br>2: Enabled (RTC)  | Default: 1<br>Range: 0 to 2                  | 193  |
| L1-22 (046D)<br><span style="border: 1px solid black; padding: 2px;">RUN</span> | Leakage Current Filter Time Constant 1               | Leakage Filter 1   | Sets the time constant for reducing the sensitivity level when detecting leakage current. Set in seconds and used when operating at constant speed.<br><b>Note:</b> This parameter is available only when C6-02 is set to B. To display this parameter, first set C6-02 = B.   | Default: 20.0 s<br>Min.: 0.0<br>Max.: 60.0   | 193  |
| L1-23 (046D)<br><span style="border: 1px solid black; padding: 2px;">RUN</span> | Leakage Current Filter Time Constant 2               | Leakage Filter 2   | Sets the time constant for reducing the sensitivity level when detecting leakage current. Set in seconds and used during acceleration and deceleration operation.<br><b>Note:</b> This parameter is available only when C6-02 is set to B. To display this parameter, first set C6-02 = B.   | Default: 1.0 s<br>Min.: 0.0<br>Max.: 60.0    | 193  |

### ◆ L2: Momentary Power Loss Ride-Thru

| No. (Addr. Hex) | Name  | LCD Display  | Description  | Values   | Page |
|-----------------|---|--|--|--|------|
| L2-01 (0485)    | Momentary Power Loss Operation Selection        | PwrL Selection<br>0: Disabled<br>1: Enbl with Timer<br>2: Enbl whl CPU act | 0: Disabled. Drive trips on Uv1 fault when power is lost.<br>1: Recover within the time set in L2-02. Uv1 will be detected if power loss is longer than L2-02.<br>2: Recover as long as CPU has power. Uv1 is not detected.  | Default: 2<br>Range: 0 to 2  | 193  |
| L2-02 (0486)    | Momentary Power Loss Ride-Thru Time             | PwrL Ridethru t  | Sets the Power Loss Ride-Thru time. Enabled only when L2-01 = 1 or 3.  | Default: <1><br>Min.: 0.0 s<br>Max.: 25.5 s                          | 194  |
| L2-03 (0487)    | Momentary Power Loss Minimum Baseblock Time     | PwrL Baseblock t   | Sets the minimum wait time for residual motor voltage decay before the drive output reenergizes after performing Power Loss Ride-Thru. Increasing the time set to L2-03 may help if overcurrent or overvoltage occur during Speed Search or during DC Injection Braking. | Default: <1><br>Min.: 0.1 s<br>Max.: 5.0 s                           | 194  |
| L2-04 (0488)    | Momentary Power Loss Voltage Recovery Ramp Time | PwrL V/F Ramp t  | Sets the time for the output voltage to return to the preset V/f pattern during Speed Search.  | Default: <1><br>Min.: 0.0 s<br>Max.: 5.0 s                           | 194  |
| L2-05 (0489)    | Undervoltage Detection Level (Uv1)              | PUV Det Level  | Sets the DC bus undervoltage trip level.   | Default: 190 Vdc <2> <3><br>Min.: 150 Vdc<br>Max.: 210 Vdc <3>       | 194  |
| L2-06 (048A)    | KEB Deceleration Time                           | KEB Decel Time   | Sets the time required to decelerate from the speed when KEB was activated to zero speed.  | Default: 0.0 s<br>Min.: 0.0<br>Max.: 200.0 <4>                       | 196  |
| L2-07 (048B)    | KEB Acceleration Time                           | KEB Accel Time   | Sets the time to accelerate to the frequency reference when momentary power loss is over. If set to 0.0, the active acceleration time is used.   | Default: 0.0 s<br>Min.: 0.0<br>Max.: 25.5 <4>                        | 196  |
| L2-08 (048C)    | Frequency Gain at KEB Start                     | KEB Freq Red   | Sets the percentage of output frequency reduction at the beginning of deceleration when the KEB Ride-Thru function is started.<br>Reduction = (slip frequency before KEB) × L2-08 × 2  | Default: 100%<br>Min.: 0<br>Max.: 300                                | 197  |
| L2-11 (0461)    | DC Bus Voltage Setpoint during KEB              | KEB DC Bus Level   | Sets the desired value of the DC bus voltage during KEB Ride-Thru.   | Default: <2><br>[E1-01] × 1.22<br>Min.: 150 Vdc<br>Max.: 400 Vdc <3> | 197  |

<1> Default setting is dependent on parameter o2-04, Drive Model Selection.

<2> Default setting is dependent on parameter E1-01, Input voltage Setting.

<3> Values shown are specific to 200 V class drives. Double the value for 400 V class drives.

<4> Setting range value is dependent on parameter C1-10, Accel/Decel Time Setting Units. When C1-10 = 0 (units of 0.01 seconds), the setting range becomes 0.00 to 600.00 seconds.

### ◆ L3: Stall Prevention

| No. (Addr. Hex) | Name   | LCD Display   | Description  | Values                                     | Page |
|-----------------|--|---|--|--|------|
| L3-01 (048F)    | Stall Prevention Selection during Acceleration | StallP Accel Sel<br>0: Disabled<br>1: General purpose<br>2: Intelligent | 0: Disabled.<br>1: General purpose. Acceleration is paused as long as the current is above the L3-02 setting.<br>2: Intelligent. Accelerate in the shortest possible time without exceeding the L3-02 level. | Default: 1<br>Range: 0 to 2                | 197  |
| L3-02 (0490)    | Stall Prevention Level during Acceleration     | StallP Accel Lvl  | Used when L3-01 = 1 or 2. 100% is equal to the drive rated current.  | Default: <1><br>Min.: 0%<br>Max.: 150% <1> | 198  |
| L3-03 (0491)    | Stall Prevention Limit during Acceleration     | StallPAcc LowLim  | Sets Stall Prevention lower limit during acceleration when operating in the constant power range. Set as a percentage of drive rated current.  | Default: 50%<br>Min.: 0<br>Max.: 100       | 198  |

| No. (Addr. Hex) | Name   | LCD Display   | Description   | Values   | Page |
|-----------------|--|---|---|--|------|
| L3-04 (0492)    | Stall Prevention Selection during Deceleration                         | StallP Decel Sel<br>0: Disabled<br>1: General purpose<br>2: Intelligent<br>3: StallP +Resistor<br>4: High Flux Brake<br>7: High Flux Brake3 | 0: Disabled. Deceleration at the active deceleration rate. An ov fault may occur.<br>1: General purpose. Deceleration is paused when the DC bus voltage exceeds the Stall Prevention level.<br>2: Intelligent. Decelerate as fast as possible while avoiding ov faults.<br>3: Stall Prevention with braking resistor. Stall Prevention during deceleration is enabled in coordination with dynamic braking.<br>4: Overexcitation Deceleration. Decelerates while increasing the motor flux.<br>7: Overexcitation Deceleration 3. Applies more braking power than normal overexcitation deceleration. Yaskawa recommends extra caution due to the heavy load on the motor. | Default: 0<br>Range: 0 to 4; 7                         | 199  |
| L3-05 (0493)    | Stall Prevention Selection during Run                                  | StallP Run Sel<br>0: Disabled<br>1: Decel time<br>2: Decel time 2   | 0: Disabled. Drive runs at a set frequency. A heavy load may cause speed loss.<br>1: Decel time 1. Uses the deceleration time set to C1-02 while Stall Prevention is performed.<br>2: Decel time 2. Uses the deceleration time set to C1-04 while Stall Prevention is performed.  | Default: 0<br>Range: 0 to 2                            | 200  |
| L3-06 (0494)    | Stall Prevention Level during Run                                      | StallP Run Level  | Enabled when L3-05 is set to 1 or 2. 100% is equal to the drive rated current.  | Default: <1><br>Min.: 30%<br>Max.: 150% <2>            | 200  |
| L3-11 (04C7)    | Overvoltage Suppression Function Selection                             | OV Inhibit Sel<br>0: Disabled<br>1: Enabled   | Enables or disables the ov suppression function, which allows the drive to change the output frequency as the load changes to prevent an ov fault.<br>0: Disabled<br>1: Enabled   | Default: 0<br>Range: 0, 1                              | 200  |
| L3-17 (0462)    | Target DC Bus Voltage for Overvoltage Suppression and Stall Prevention | DC Bus Reg Level  | Sets the desired value for the DC bus voltage during overvoltage suppression and Stall Prevention during deceleration.  | Default: 375 Vdc <2> <3><br>Min.: 150<br>Max.: 400 <3> | 200  |
| L3-20 (0465)    | DC Bus Voltage Adjustment Gain   | DC Bus P Gain   | Sets the proportional gain for KEB Ride-Thru, Stall Prevention, and overvoltage suppression.  | Default: 1.00<br>Min.: 0.00<br>Max.: 5.00              | 201  |
| L3-21 (0466)    | Accel/Decel Rate Calculation Gain                                      | Acc/Dec P Gain  | Sets the proportional gain used to calculate the deceleration rate during KEB Ride-Thru, ov suppression function, and Stall Prevention during deceleration (L3-04 = 2).   | Default: 1.00<br>Min.: 0.10<br>Max.: 10.00             | 201  |
| L3-23 (04FD)    | Automatic Reduction Selection for Stall Prevention during Run          | CHP Stall P Sel<br>0: Lv1 set in L3-06<br>1: Autom. Reduction   | 0: Sets the Stall Prevention level set in L3-06 that is used throughout the entire frequency range.<br>1: Automatic Stall Prevention level reduction in the constant output range. The lower limit value is 40% of L3-06.   | Default: 0<br>Range: 0, 1                              | 201  |
| L3-24 (046E)    | Motor Acceleration Time for Inertia Calculations                       | Mtr Accel Time  | Sets the time needed to accelerate the uncoupled motor at rated torque from stop to the maximum frequency.  | Default: <4> <5><br>Min: 0.001 s<br>Max: 10.000 s      | 202  |
| L3-25 (046F)    | Load Inertia Ratio   | Load Inertia Rat  | Sets the ratio between the motor and machine inertia.   | Default: 1.0<br>Min.: 1.0<br>Max.: 1000.0              | 202  |

- <1> Upper limit is dependent on parameter L8-38, Frequency Reduction Selection.
- <2> Default setting is dependent on parameter E1-01, Input voltage Setting.
- <3> Values shown are specific to 200 V class drives. Double the value for 400 V class drives.
- <4> Parameter value changes automatically if E2-11 is manually changed or changed by Auto-Tuning.
- <5> Default setting is dependent on parameter o2-04, Drive Model Selection.

**◆ L4: Speed Detection**

| No. (Addr. Hex) | Name   | LCD Display  | Description   | Values   | Page |
|-----------------|--|--|---|--|------|
| L4-01 (0499)    | Speed Agreement Detection Level              | Spd Agree Level  | L4-01 sets the frequency detection level for digital output functions H2-□□ = 2, 3, 4, 5.   | Default: 0.0 Hz<br>Min.: 0.0<br>Max.: 400.0    | 202  |
| L4-02 (049A)    | Speed Agreement Detection Width              | Spd Agree Width  | L4-02 sets the hysteresis or allowable margin for speed detection.  | Default: 2.0<br>Min.: 0.0<br>Max.: 20.0        | 202  |
| L4-03 (049B)    | Speed Agreement Detection Level (+/-)        | Spd Agree Lvl+-  | L4-03 sets the frequency detection level for digital output functions H2-□□ = 13, 14, 15, 16.   | Default: 0.0 Hz<br>Min.: -400.0<br>Max.: 400.0 | 203  |
| L4-04 (049C)    | Speed Agreement Detection Width (+/-)        | Spd Agree Wdth+-   | L4-04 sets the hysteresis or allowable margin for speed detection.  | Default: 2.0<br>Min.: 0.0<br>Max.: 20.0        | 203  |
| L4-05 (049D)    | Frequency Reference Loss Detection Selection | Ref Loss Sel<br>0: Stop<br>1: Run@L4-06PrevRef               | 0: Stop. Drive stops when the frequency reference is lost.<br>1: Run. Drive runs at a reduced speed when the frequency reference is lost. | Default: 0<br>Range: 0, 1                      | 203  |
| L4-06 (04C2)    | Frequency Reference at Reference Loss        | Fref at Floss  | Sets the percentage of the frequency reference that the drive should run with when the frequency reference is lost.                       | Default: 80.0%<br>Min.: 0.0<br>Max.: 100.0     | 203  |
| L4-07 (0470)    | Speed Agreement Detection Selection          | Freq Detect Sel<br>0: No Detection @BB<br>1: Always Detected | 0: No detection during baseblock.<br>1: Detection always enabled.   | Default: 0<br>Range: 0, 1                      | 203  |

**◆ L5: Fault Restart**

| No. (Addr. Hex) | Name  | LCD Display  | Description  | Values  | Page |
|-----------------|---|--|--|---|------|
| L5-01 (049E)    | Number of Auto Restart Attempts               | Num of Restarts  | Sets the number of times the drive may attempt to restart after the following faults occur: GF, LF, oC, oH1, ov, PF, rH, rr, oL1, oL2, oL3, oL4, STo, Uv1. | Default: 5<br>Min.: 0<br>Max.: 10             | 204  |
| L5-02 (049F)    | Auto Restart Fault Output Operation Selection | Restart Sel<br>0: Flt Outp Disabl<br>1: Flt Outp Enabled | 0: Fault output not active.<br>1: Fault output active during restart attempt.  | Default: 0<br>Range: 0, 1                     | 204  |
| L5-04 (046C)    | Fault Reset Interval Time                     | Flt Reset Wait T   | Sets the amount of time to wait between performing fault restarts.   | Default: 20.0 s<br>Min.: 10.0<br>Max.: 3600.0 | 204  |
| L5-40 (0670)    | Low Feedback Fault Retry Selection            | Low Feedback<br>0: No retry<br>1: Retry                  | Determines whether the LFB-Low Feedback fault can be auto-restarted.   | Default: 0<br>Range: 0, 1                     | 205  |
| L5-41 (0671)    | High Feedback Fault Retry Selection           | High Feedback<br>0: No retry<br>1: Retry                 | Determines whether the HFB-High Feedback fault can be auto-restarted.  | Default: 0<br>Range: 0, 1                     | 205  |
| L5-42 (0672)    | Feedback Loss Fault Retry Selection           | Feedback Loss<br>0: No retry<br>1: Retry                 | Determines whether the FBL-Feedback Loss fault can be auto-restarted.  | Default: 0<br>Range: 0, 1                     | 205  |
| L5-50 (067A)    | Setpoint Not Met Retry Selection              | SetPoint Not Met<br>0: No retry<br>1: Retry              | Determines whether the NMS-Setpoint not Met fault can be auto-restarted.   | Default: 0<br>Range: 0, 1                     | 205  |
| L5-51 (067B)    | Loss of Prime Fault Retry Selection           | High Feedback<br>0: No retry<br>1: Retry                 | Determines whether the LOP-Loss of Prime fault can be auto-restarted.  | Default: 0<br>Range: 0, 1                     | 205  |

| No. (Addr. Hex) | Name                                  | LCD Display                                 | Description  | Values                    | Page |
|-----------------|---------------------------------------|---|--|---------------------------|------|
| L5-52 (067C)    | Pump Over Cycle Fault Retry Selection | Pump Over Cycle<br>0: No retry<br>1: Retry  | Determines whether the POC-Pump Over Cycle fault can be auto-restarted.<br>0: No retry<br>1: Retry   | Default: 0<br>Range: 0, 1 | 205  |
| L5-53 (067D)    | Volute-TStat Retry Selection          | Volute-TStat Flt<br>0: No retry<br>1: Retry | Determines whether the Volute T-Stat fault can be auto-restarted.<br>0: No retry<br>1: Retry<br><br><b>Note:</b> The drive will restart only after the Volute-Tstat digital input deactivates and the L5-04 timer expires. | Default: 0<br>Range: 0, 1 | 205  |

◆ L6: Torque Detection

| No. (Addr. Hex) | Name                         | LCD Display  | Description  | Values                                     | Page |
|-----------------|------------------------------|--|--|--|------|
| L6-01 (04A1)    | Torque Detection Selection 1 | Torq Det 1 Sel<br>0: Disabled<br>1: OL Alm at SpdAgr<br>2: OL Alm dur RUN<br>3: OL Flt at SpdAgr<br>4: OL Flt dur RUN<br>5: UL Alm at SpdAgr<br>6: UL Alm dur RUN<br>7: UL Flt at SpdAgr<br>8: UL Flt dur RUN<br>9: UL6Alm at SpdAgr<br>10: UL6Alm dur RUN<br>11: UL6Flt at SpdAgr<br>12: UL6Flt dur RUN | 0: Disabled<br>1: oL3 detection only active during speed agree, operation continues after detection<br>2: oL3 detection always active during run, operation continues after detection<br>3: oL3 detection only active during speed agree, output shuts down on an oL3 fault<br>4: oL3 detection always active during run, output shuts down on an oL3 fault<br>5: UL3 detection only active during speed agree, operation continues after detection<br>6: UL3 detection always active during run, operation continues after detection<br>7: UL3 detection only active during speed agree, output shuts down on an oL3 fault<br>8: UL3 detection always active during run, output shuts down on an oL3 fault<br>9: UL6 Alarm at Speed Agree<br>10: UL6 Alarm during Run<br>11: UL6 Fault at Speed Agree<br>12: UL6 Fault during Run | Default: 0<br>Range: 0 to 12               | 206  |
| L6-02 (04A2)    | Torque Detection Level 1     | Torq Det 1 Lvl   | Sets the overtorque and undertorque detection level.   | Default: 15%<br>Min.: 0<br>Max.: 300       | 207  |
| L6-03 (04A3)    | Torque Detection Time 1      | Torq Det 1 Time  | Sets the time an overtorque or undertorque condition must exist to trigger torque detection 1.   | Default: 10.0 s<br>Min.: 0.0<br>Max.: 10.0 | 207  |
| L6-04 (04A4)    | Torque Detection Selection 2 | Torq Det 2 Sel<br>0: Disabled<br>1: OL Alm at SpdAgr<br>2: OL Alm dur RUN<br>3: OL Flt at SpdAgr<br>4: OL Flt dur RUN<br>5: UL Alm at SpdAgr<br>6: UL Alm dur RUN<br>7: UL Flt at SpdAgr<br>8: UL Flt dur RUN  | 0: Disabled<br>1: oL4 detection only active during speed agree, operation continues after detection<br>2: oL4 detection always active during run, operation continues after detection<br>3: oL4 detection only active during speed agree, output shuts down on an oL4 fault<br>4: oL4 detection always active during run, output shuts down on an oL4 fault<br>5: UL4 detection only active during speed agree, operation continues after detection<br>6: UL4 detection always active during run, operation continues after detection<br>7: UL4 detection only active during speed agree, output shuts down on an oL4 fault<br>8: UL4 detection always active during run, output shuts down on an oL4 fault  | Default: 0<br>Range: 0 to 8                | 206  |
| L6-05 (04A5)    | Torque Detection Level 2     | Torq Det 2 Lvl   | Sets the overtorque and undertorque detection level.   | Default: 150%<br>Min.: 0<br>Max.: 300      | 207  |

## B.9 L: Protection Function

| No. (Addr. Hex) | Name  | LCD Display   | Description   | Values                                    | Page |
|-----------------|---|---|---|---|------|
| L6-06 (04A6)    | Torque Detection Time 2                               | Torq Det 2 Time   | Sets the time an overtorque or undertorque condition must exist to trigger torque detection 2.                        | Default: 0.1 s<br>Min.: 0.0<br>Max.: 10.0 | 207  |
| L6-13 (062E)    | Motor Underload Protection Selection                  | Underload Select<br>0: Base Freq Enable<br>1: Max Freq Enable | Sets the motor underload protection (UL6) based on motor load.<br>0: Base frequency enable<br>1: Max frequency enable | Default: 0<br>Range: 0, 1                 | 206  |
| L6-14 (062F)    | Motor Underload Protection Level at Minimum Frequency | Underload Level   | Sets the UL6 detection level at minimum frequency by percentage of drive rated current.                               | Default: 15%<br>Min.: 0<br>Max.: 300      | 206  |

## ◆ L8: Drive Protection

| No. (Addr. Hex) | Name  | LCD Display   | Description   | Values                                      | Page |
|-----------------|---|---|---|---|------|
| L8-01 (04AD)    | Internal Dynamic Braking Resistor Protection Selection (ERF type) | DB Resistor Prot<br>0: Not Provided<br>1: Provided  | 0: Resistor overheat protection disabled<br>1: Resistor overheat protection enabled   | Default: 0<br>Range: 0, 1                   | 208  |
| L8-02 (04AE)    | Overheat Alarm Level  | OH Pre-Alarm Lvl  | An overheat alarm occurs when heatsink temperature exceeds the L8-02 level.   | Default: </><br>Min.: 50 °C<br>Max.: 130 °C | 208  |
| L8-03 (04AF)    | Overheat Pre-Alarm Operation Selection                            | OH Pre-Alarm Sel<br>0: Ramp to stop<br>1: Coast to stop<br>2: Fast-Stop<br>3: Alarm only<br>4: Run@L8-19 Rate | 0: Ramp to stop. A fault is triggered.<br>1: Coast to stop. A fault is triggered.<br>2: Fast Stop. Decelerate to stop using the deceleration time in C1-09. A fault is triggered.<br>3: Continue operation. An alarm is triggered.<br>4: Continue operation at reduced speed as set in L8-19. | Default: 3<br>Range: 0 to 4                 | 208  |
| L8-05 (04B1)    | Input Phase Loss Protection Selection                             | Inp Ph Loss Det<br>0: Disabled<br>1: Enabled  | Selects the detection of input current phase loss, power supply voltage imbalance, or main circuit electrolytic capacitor deterioration.<br>0: Disabled<br>1: Enabled   | Default: 1<br>Range: 0, 1                   | 209  |
| L8-07 (04B3)    | Output Phase Loss Protection Selection                            | Outp Ph Loss Det<br>0: Disabled<br>1: 1PH Loss Det<br>2: 2/3PH Loss Det                                       | 0: Disabled<br>1: Enabled (triggered by a single phase loss)<br>2: Enabled (triggered when two phases are lost)   | Default: 1<br>Range: 0 to 2                 | 209  |
| L8-09 (04B5)    | Output Ground Fault Detection Selection                           | Grnd Flt Det Sel<br>0: Disabled<br>1: Enabled   | 0: Disabled<br>1: Enabled   | Default: 0<br>Range: 0, 1                   | 210  |
| L8-10 (04B6)    | Heatsink Cooling Fan Operation Selection                          | Fan On/Off Sel<br>0: Dur Run (OffDly)<br>1: Always On   | 0: During run only. Fan operates only during run for L8-11 seconds after stop.<br>1: Fan always on. Cooling fan operates whenever the drive is powered up.  | Default: 0<br>Range: 0, 1                   | 210  |
| L8-11 (04B7)    | Heatsink Cooling Fan Off Delay Time                               | Fan Delay Time  | Sets a delay time to shut off the cooling fan after the Run command is removed when L8-10 = 0.  | Default: 300 s<br>Min.: 0<br>Max.: 300      | 210  |
| L8-12 (04B8)    | Ambient Temperature Setting                                       | Ambient Temp  | Enter the ambient temperature. This value adjusts the oL2 detection level.  | Default: 40 °C<br>Min.: -10<br>Max.: 50     | 210  |
| L8-15 (04BB)    | oL2 Characteristics Selection at Low Speeds                       | OL2 Sel @ L-Spd<br>0: Disabled<br>1: Enabled  | 0: No oL2 level reduction below 6 Hz.<br>1: oL2 level is reduced linearly below 6 Hz. It is halved at 0 Hz.   | Default: 1<br>Range: 0, 1                   | 210  |
| L8-18 (04BE)    | Software Current Limit Selection                                  | Soft CLA Sel<br>0: Disabled<br>1: Enabled   | 0: Disabled<br>1: Enabled   | Default: 0<br>Range: 0, 1                   | 211  |
| L8-19 (04BF)    | Frequency Reduction Rate during Overheat Pre-Alarm                | Fc Red dur OHAlm  | Specifies the frequency reference reduction gain at overheat pre-alarm when L8-03 = 4.  | Default: 0.8<br>Min.: 0.1<br>Max.: 0.9      | 209  |

| No. (Addr. Hex) | Name                                       | LCD Display  | Description  | Values                                      | Page |
|-----------------|--|--|--|---|------|
| L8-35 (04EC)    | Installation Method Selection              | Installation Sel<br>0: IP00/OpenChassis<br>1: Side-by-Side<br>2: IP20/Nema 1, UL Type 1<br>3: ExternalHeatsink | 0: IP00/Open-Chassis enclosure<br>1: Side-by-Side mounting<br>2: IP20/NEMA 1, UL Type 1 enclosure<br>3: Finless model drive or external heatsink installation                              | Default: <1> <2><br>Range: 0 to 3           | 211  |
| L8-38 (04EF)    | Carrier Frequency Reduction                | Fc Reduct dur OL<br>0: Disabled<br>1: Active below 6Hz<br>2: Active @ any Spd                                  | 0: Disabled<br>1: Enabled below 6 Hz<br>2: Enabled for the entire speed range  | Default: 1<br>Range: 0 to 2                 | 211  |
| L8-40 (04F1)    | Carrier Frequency Reduction Off Delay Time | Fc Reduct Time   | Sets the time that the drive continues running with reduced carrier frequency after the carrier reduction condition is gone. Setting 0.00 s disables the carrier frequency reduction time. | Default: 0.50 s<br>Min.: 0.00<br>Max.: 2.00 | 212  |
| L8-41 (04F2)    | High Current Alarm Selection               | High Cur Alm Sel<br>0: Disabled<br>1: Enabled  | 0: Disabled<br>1: Enabled. An alarm is triggered at output currents above 150% of drive rated current.   | Default: 0<br>Range: 0, 1                   | 212  |

<1> Default setting is dependent on parameter o2-04, Drive Model Selection.

<2> Parameter setting value is not reset to the default value when the drive is initialized.

## B.10 n: Advanced Performance Set-Up

The n parameters adjust more advanced performance characteristics.

### ◆ n1: Hunting Prevention

| No. (Addr. Hex) | Name                                     | LCD Display                                   | Description   | Values                                     | Page |
|-----------------|--|---|---|--|------|
| n1-01 (0580)    | Hunting Prevention Selection             | Hunt Prev Select<br>0: Disabled<br>1: Enabled | 0: Disabled<br>1: Enabled   | Default: 1<br>Range: 0, 1                  | 213  |
| n1-02 (0581)    | Hunting Prevention Gain Setting          | Hunt Prev Gain                                | If the motor vibrates while lightly loaded, increase the gain by 0.1 until vibration ceases. If the motor stalls, decrease the gain by 0.1 until the stalling ceases. | Default: 1.00<br>Min.: 0.00<br>Max.: 2.50  | 213  |
| n1-03 (0582)    | Hunting Prevention Time Constant         | Hunt Prev Time                                | Sets the time constant used for Hunting Prevention.   | Default: <1><br>Min.: 0 ms<br>Max.: 500 ms | 213  |
| n1-05 (0530)    | Hunting Prevention Gain while in Reverse | Hprev Gain @Rev                               | Sets the gain used for Hunting Prevention. If set to 0, the gain set to n1-02 is used for operation in reverse.   | Default: 0.00<br>Min.: 0.00<br>Max.: 2.50  | 213  |

<1> Default setting is dependent on parameter o2-04, Drive Model Selection.

### ◆ n3: Overexcitation Braking

| No. (Addr. Hex) | Name                                | LCD Display  | Description  | Values                                    | Page |
|-----------------|-------------------------------------|--|--|---|------|
| n3-13 (0531)    | Overexcitation Deceleration Gain    | Hflux Brake Gain   | Applies a gain to the V/f pattern during deceleration (L3-04 = 4). Returns to normal values after ramp to stop or at re-acceleration.<br>To increase the braking power of overexcitation, increase the gain by 1.25 to 1.30. | Default: 1.10<br>Min.: 1.00<br>Max.: 1.40 | 213  |
| n3-21 (0579)    | High-Slip Suppression Current Level | Hflux I Supp Lvl   | Sets output current level at which the drive will start reducing the overexcitation gain in order to prevent a too high motor slip during Overexcitation Deceleration. Set as a percentage of the drive rated current.       | Default: 100%<br>Min.: 0<br>Max.: 150     | 214  |
| n3-23 (057B)    | Overexcitation Operation Selection  | Hflux Brake Sel<br>0: Enabled-Both Dir<br>1: Enabled-Fwd only<br>2: Enabled-Rev only | 0: Enabled in both directions<br>1: Enabled only when rotating forward<br>2: Enabled only when in reverse  | Default: 0<br>Range: 0 to 2               | 214  |



## B.11 o: Operator Related Parameters

o parameters set up the digital operator displays.

### ◆ o1: HOA Keypad Display Selection

| No. (Addr. Hex)        | Name                                  | LCD Display   | Description  | Values   | Page |
|------------------------|---------------------------------------|---|--|--|------|
| o1-01<br>(0500)<br>RUN | Drive Mode Unit Monitor Selection     | User Monitor Sel  | Selects the content of the last monitor that is shown when scrolling through Drive Mode display. Enter the last three digits of the monitor parameter number to be displayed: U□-□□.   | Default: 106<br>(Monitor U1-06)<br>Range: 104 to 904 | 215  |
| o1-02<br>(0501)<br>RUN | User Monitor Selection after Power Up | Power-On Monitor<br>1: Frequency Ref<br>2: FWD/REV<br>3: Output Freq<br>4: Output Current<br>5: User Monitor  | 1: Frequency reference (U1-01)<br>2: Direction<br>3: Output frequency (U1-02)<br>4: Output current (U1-03)<br>5: User-selected monitor (set by o1-01)  | Default: 1<br>Range: 1 to 5                          | 215  |
| o1-03<br>(0502)        | Digital Operator Display Selection    | Display Unit Sel<br>0: 0.01 Hz<br>1: 0.01%<br>2: r/min<br>3: User Units   | Sets the units the drive should use to display the frequency reference and motor speed monitors.<br>0: 0.01 Hz<br>1: 0.01% (100% = E1-04)<br>2: r/min (calculated using the number of motor poles setting in E2-04)<br>3: User-selected units (set by o1-09, o1-10 and o1-11)  | Default: 0<br>Range: 0 to 3                          | 215  |
| o1-05<br>(0504)<br>RUN | LCD Contrast Control                  | LCD Contrast  | Sets the brightness of the optional LCD operator.  | Default: 3<br>Range: 0 to 5                          | 216  |
| o1-06<br>(0517)        | User Monitor Selection Mode           | Monitor Mode Sel<br>0: 3 Mon Sequential<br>1: 3 Mon Selectable  | Selects the monitors displayed on the second and third lines of the digital operator display.<br>0: 3 Monitor Sequential (displays the next two sequential monitors)<br>1: 3 Monitor Selectable (set by o1-07 and o1-08)   | Default: 1<br>Range: 0, 1                            | 215  |
| o1-07<br>(0518)        | Second Line Monitor Selection         | 2nd Monitor Sel   | Selects the monitor that is shown in the second line. Enter the last three digits of the monitor parameter number to be displayed: U□-□□. For example, set "403" to display monitor parameter U4-03.<br><b>Note:</b> Parameter is effective only when o1-06 is set to 1.   | Default: 102<br>Range: 101 to 904                    | 215  |
| o1-08<br>(0519)        | Third Line Monitor Selection          | 3rd Monitor Sel   | Selects the monitor that is shown in the third line. Enter the last three digits of the monitor parameter number to be displayed: U□-□□. For example, set "403" to display monitor parameter U4-03.<br><b>Note:</b> Parameter is effective only when o1-06 is set to 1.  | Default: 191<br>Range: 101 to 904                    | 215  |
| o1-09<br>(051C)        | Frequency Reference Display Units     | Fref Disp Unit<br>0: "WC:InchOfWater<br>1: PSI :lb/SqrInch<br>2: GPM:Gallons/Min<br>3: °F:DegFahrenheit<br>4: CFM:Cubic ft/Min<br>5: CMH:Cubic m/Hr<br>6: LPH:Litres/Hr<br>7: LPS:Litres/Sec<br>8: Bar:Bar<br>9: Pa:Pascals<br>10: °C:DegCelsius<br>11: m: meters<br>12: ft: feet<br>13: LPM:Litres/Min<br>14: CMM:Cubic M/Min<br>15: "Hg:Inch Mercury<br>25: No Unit | Sets unit display for the frequency reference parameters and frequency related monitors when o1-03 = 3.<br>0: WC (Inch of water)<br>1: PSI (Pounds per square inch)<br>2: GPM (Gallons per minute)<br>3: F (Degrees Fahrenheit)<br>4: CFM (Cubic feet per minute)<br>5: CMH (Cubic meters per hour)<br>6: LPH (Liters per hour)<br>7: LPS (Liters per second)<br>8: Bar (Bar)<br>9: Pa (Pascal)<br>10: C (Degrees Celsius)<br>11: Mtr (Meters)<br>12: Ft (Feet)<br>13: LPM (Liters per minute)<br>14: CMM (Cubic meters per minute)<br>15: "Hg (inches of mercury)<br>25: None | Default: 25<br>Range: 0 to 15;<br>25                 | 215  |

## B.11 o: Operator Related Parameters

| No. (Addr. Hex)       | Name                                   | LCD Display                                   | Description  | Values                            | Page |
|-----------------------|--|---|--|-----------------------------------|------|
| o1-10 (0520)          | User-Set Display Units Maximum Value   | UserDisp Scaling                              | These settings define the display values when o1-03 is set to 3. o1-10 sets the display value that is equal to the maximum output frequency.<br>o1-11 sets the position of the decimal position. | Default: <1><br>Range: 1 to 60000 | 217  |
| o1-11 (0521)          | User-Set Display Units Decimal Display | UserDisp Dec                                  |  | Default: <1><br>Range: 0 to 3     | 217  |
| o1-12 (0522)<br>[RUN] | Home Help Text                         | Top Help on Home<br>0: Disabled<br>1: Enabled | Switches the top line of the Home Screen from the Drive Status to defined Help messages.<br>0: Disabled<br>1: Enabled  | Default: 1<br>Range: 0, 1         | 217  |

<1> Default setting is dependent on parameter o1-03, Digital Operator Display Selection.

### ◆ o2: HOA Keypad Keypad Functions

| No. (Addr. Hex)       | Name  | LCD Display   | Description   | Values                                   | Page |
|-----------------------|---|---|---|--|------|
| o2-02 (0506)          | STOP Key Function Selection                               | Oper STOP Key<br>0: Disabled<br>1: Enabled                                  | 0: Disabled. STOP key is disabled in REMOTE operation.<br>1: Enabled. STOP key is always enabled.   | Default: 1<br>Range: 0, 1                | 217  |
| o2-03 (0507)          | User Parameter Default Value                              | User Default Sel<br>0: No Change<br>1: Save User Init<br>2: Clear User Init | 0: No change.<br>1: Set defaults. Saves parameter settings as default values for a User Initialization.<br>2: Clear all. Clears the default settings that have been saved for a User Initialization.  | Default: 0<br>Range: 0 to 2              | 218  |
| o2-04 (508)           | Drive Model Selection                                     | Inverter Model #  | Enter the drive model. Setting required only if installing a new control board.   | Default:<br>Determined by drive capacity | 218  |
| o2-05 (0509)          | Frequency Reference Setting Method Selection              | Oper Ref Method<br>0: Disabled<br>1: Enabled                                | 0: ENTER key must be pressed to enter a frequency reference.<br>1: ENTER key is not required. The frequency reference can be adjusted using the up and down arrow keys only.  | Default: 0<br>Range: 0, 1                | 218  |
| o2-06 (050A)          | Operation Selection when Digital Operator is Disconnected | Oper Discon Det<br>0: Disabled<br>1: Enabled                                | 0: The drive continues operating if the digital operator is disconnected.<br>1: An oPr fault is triggered and the motor coasts to stop.   | Default: 0<br>Range: 0, 1                | 219  |
| o2-07 (0527)          | Motor Direction at Power Up when Using Operator           | For/RevSel@PwrUp<br>0: Forward<br>1: Reverse                                | This parameter requires assigning drive operation to the digital operator.<br>0: Forward<br>1: Reverse  | Default: 0<br>Range: 0, 1                | 219  |
| o2-30 (1230)<br>[RUN] | Monitor Position Save                                     | Mon Pos Save<br>0: Disabled<br>1: Enabled                                   | Saves the monitor position and Home Screen quick monitor selection.<br>Setting this parameter to 0 and then entering the Monitor Menu will jump the selection to the monitor number instead of the group number.<br>0: Disabled<br>1: Enabled | Default: 0<br>Range: 0, 1                | 219  |

### ◆ o3: Copy Function

| No. (Addr. Hex) | Name                    | LCD Display   | Description   | Values                      | Page |
|-----------------|-------------------------|---|---|-----------------------------|------|
| o3-01 (0515)    | Copy Function Selection | COPY SELECT<br>0: COPY SELECT<br>1: INV→OP READ<br>2: OP→INV WRITE<br>3: OP←→INV VERIFY | 0: No action<br>1: Read parameters from the drive, saving them onto the digital operator.<br>2: Copy parameters from the digital operator, writing them to the drive.<br>3: Verify parameter settings on the drive to check if they match the data saved on the operator. | Default: 0<br>Range: 0 to 3 | 219  |
| o3-02 (0516)    | Copy Allowed Selection  | Read Allowable<br>0: Disabled<br>1: Enabled   | 0: Read operation prohibited<br>1: Read operation allowed   | Default: 1<br>Range: 0, 1   | 220  |

## ◆ o4: Maintenance Monitor Settings

| No.<br>(Addr.<br>Hex) | Name  | LCD Display  | Description  | Values                              | Page                |
|-----------------------|---|--|--|-------------------------------------|---------------------|
| o4-01<br>(050B)       | Cumulative Operation Time Setting             | DrvElapsTimeCnt  | Sets the value for the cumulative operation time of the drive in units of 10 h.  | Default: 0<br>Min.: 0<br>Max.: 9999 | <a href="#">220</a> |
| o4-02<br>(050C)       | Cumulative Operation Time Selection           | ElapsTimeCntSet<br>0: Power-On Time<br>1: Running Time | 0: Logs power-on time<br>1: Logs operation time when the drive output is active (output operation time).   | Default: 1<br>Range: 0, 1           | <a href="#">220</a> |
| o4-03<br>(050E)       | Cooling Fan Operation Time Setting            | FanElapsTimeCn   | Sets the value of the fan operation time monitor U4-03 in units of 10 h.   | Default: 0<br>Min.: 0<br>Max.: 9999 | <a href="#">220</a> |
| o4-05<br>(051D)       | Capacitor Maintenance Setting                 | BusCap Maint Set                                       | Sets the value of the Maintenance Monitor for the capacitors. See U4-05 to check when the capacitors may need to be replaced.  | Default: 0%<br>Min.: 0<br>Max.: 150 | <a href="#">220</a> |
| o4-07<br>(0523)       | DC Bus Pre-Charge Relay Maintenance Setting   | ChrgCircMaintSet                                       | Sets the value of the Maintenance Monitor for the soft charge bypass relay. See U4-06 to check when the bypass relay may need to be replaced.                              | Default: 0%<br>Min.: 0<br>Max.: 150 | <a href="#">221</a> |
| o4-09<br>(0525)       | IGBT Maintenance Setting                      | IGBT Maint Set   | Sets the value of the Maintenance Monitor for the IGBTs. See U4-07 for IGBT replacement times.   | Default: 0%<br>Min.: 0<br>Max.: 150 | <a href="#">221</a> |
| o4-11<br>(0510)       | U2, U3 Initialization                         | Fault Data Init<br>0: No Reset<br>1: Reset             | 0: U2-□□ and U3-□□ monitor data is not reset when the drive is initialized (A1-03).<br>1: U2-□□ and U3-□□ monitor data is reset when the drive is initialized (A1-03).     | Default: 0<br>Range: 0, 1           | <a href="#">221</a> |
| o4-12<br>(0512)       | kWh Monitor Initialization                    | kWh Monitor Init<br>0: No Reset<br>1: Reset            | 0: U4-10 and U4-11 monitor data is not reset when the drive is initialized (A1-03).<br>1: U4-10 and U4-11 monitor data is reset when the drive is initialized (A1-03).     | Default: 0<br>Range: 0, 1           | <a href="#">221</a> |
| o4-13<br>(0528)       | Number of Run Commands Counter Initialization | Run Counter Init<br>0: No Reset<br>1: Reset            | 0: Number of Run commands counter is not reset when the drive is initialized (A1-03).<br>1: Number of Run commands counter is reset when the drive is initialized (A1-03). | Default: 0<br>Range: 0, 1           | <a href="#">221</a> |
| o4-17<br>(3100)       | Set/Reset Real-Time Clock                     | Date/Time Config<br>0: — —<br>1: Set<br>2: Reset       | Sets the current date and time for the Real-Time Clock.<br>0: - -<br>1: Set<br>2: Reset  | Default: 0<br>Range: 0 to 2         | <a href="#">222</a> |
| o4-20<br>(081F)       | Time Display Format                           | Time Disp Format<br>0: 12-hour (AM/PM)<br>1: 24-hour   | Sets the time display format.<br>0: 12-hour<br>1: 24-hour  | Default: 0<br>Range: 0, 1           | <a href="#">222</a> |

## B.12 P: Pump Parameters

### ◆ P1: Pump Basic

| No. (Addr. Hex)        | Name                                | LCD Display  | Description   | Values   | Page |
|------------------------|-------------------------------------|--|---|--|------|
| P1-01<br>(0C00)        | Pump Mode                           | Pump Mode<br>0: Drive Only<br>3: Memobus Network   | 0: Drive only<br>3: MEMOBUS network   | Default: 0<br>Range: 0, 3                              | 223  |
| P1-02<br>(0C01)        | System Units                        | System Units<br>0: No Unit<br>1: PSI :lb/SqrInch<br>2: Pa:Pascals<br>3: Bar:Bar<br>4: "WC:InchOfWater<br>5: "Hg:Inch Mercury<br>6: ft: feet<br>7: m: meters<br>8: °F:DegFahrenheit<br>9: °C:DegCelsius<br>10: %: Percent | 0: No unit<br>1: PSI: Pounds per square inch<br>2: Pa: Pascals<br>3: Bar: Bar<br>4: "WC: Inch of water<br>5: "Hg: Inch of Mercury<br>6: ft: feet<br>7: m: meters<br>8: °F: Degrees Fahrenheit<br>9: °C: Degrees Celsius<br>10: Percent  | Default: 1<br>Range: 0 to 10                           | 223  |
| P1-03<br>(0C02)        | Feedback Device Scaling             | Fb Device Scaling  | Sets the scaling of feedback device in user-set units.  | Default: 145.0<br>PSI <=><br>Min.: 0.1<br>Max.: 6000.0 | 223  |
| P1-04<br>(0C03)<br>RUN | Start / Draw Down Level             | Start-DrawDn Lvl   | The system starts when the feedback level drops below the start level for the time set in P1-05. This level also specifies the wake-up level when the drive is in Sleep Mode. When this parameter is set to a negative value, the feedback level must drop that amount below the setpoint. Setting this parameter to 0.0 disables the function. When P1-01, Pump Mode, is set to 3 (MEMOBUS network), this function is active only on the first drive in the network.<br><br><b>Note:</b> When PID operates in reverse mode, the system will start when the feedback has risen above the start level for the time set to P1-05. | Default: 0.0 PSI<br><=><br>Min.: -999.9<br>Max.: 999.9 | 224  |
| P1-05<br>(0C02)<br>RUN | Start Level Delay Time              | S-Lev Delay Time   | The system starts when the feedback level drops below the start level for the time set in this parameter.   | Default: 1 s<br>Min.: 0<br>Max.: 3600                  | 224  |
| P1-06<br>(0C05)<br>RUN | Minimum Pump Speed                  | Min. Pump Speed  | Minimum frequency at which the drive will run. Applies to both HAND and AUTO modes.<br><br><b>Note:</b> For minimum pump frequency, the drive will use the highest setting from among P1-06, P4-12 (Thrust Bearing Frequency), or d2-02 (Reference Lower Limit).  | Default: 40.0 Hz<br><=><br>Min.: 0.0<br>Max.: [E1-04]  | 224  |
| P1-07<br>(0C06)<br><=> | Minimum Pump Speed Units            | MinPumpSpdUnits<br>0: Hz<br>1: RPM   | Sets the units and decimal place for parameter P1-06.<br>0: Hz<br>1: RPM<br><br><b>Note:</b> Changing this parameter will reset the P1-06 default value.  | Default: 0<br>Range: 0, 1                              | 224  |
| P1-08<br>(0C07)<br>RUN | Low Feedback Level                  | Low FB Level   | Sets the lower detection level for the PID feedback.  | Default: 0.0 PSI<br><=><br>Min.: 0.0<br>Max.: 6000.0   | 224  |
| P1-09<br>(0C08)<br>RUN | Low Feedback Level Fault Delay Time | Low Lvl FLT Time   | Sets the amount of delay time from when the low feedback is detected until the drive faults on an "LFB Low Feedback" fault.<br><br><b>Note:</b> This parameter is effective only when P1-10 is set to 0 (Fault).  | Default: 10 s<br>Min.: 0<br>Max.: 3600                 | 224  |
| P1-10<br>(0C09)        | Low Feedback Selection              | Low FB Sel<br>0: Fault<br>1: Alarm<br>2: Digital Output  | Selects drive response during the "Low Feedback" condition.<br>0: Fault<br>1: Alarm<br>2: Digital out only  | Default: 0<br>Range: 0 to 2                            | 224  |

| No. (Addr. Hex)        | Name   | LCD Display   | Description  | Values  | Page |
|------------------------|--|---|--|---|------|
| P1-11<br>(0C0A)<br>RUN | High Feedback Level                            | High FB Level   | Sets the upper detection level for the PID feedback.<br><b>Note:</b> When P1-03 is set to 3, parameter P9-18 uses the value set here to calculate quick de-stage feedback level.   | Default: 155.0 PSI <2><br>Min.: 0.0<br>Max.: 6000.0 | 225  |
| P1-12<br>(0C0B)<br>RUN | High Feedback Level Fault Delay Time           | High Lvl FLT Time   | Sets the amount of delay time from when the high feedback is detected until the drive faults on a “HFB High Feedback” fault.<br><b>Note:</b> This parameter is effective only when P1-13 is set to 0 (Fault (and digital out)).  | Default: 5 s<br>Min.: 0<br>Max.: 3600               | 225  |
| P1-13<br>(0C0C)        | High Feedback Selection                        | High FB Sel<br>0: Fault<br>1: Alarm<br>2: Digital Output            | Selects drive response during the “High Feedback” condition.<br>0: Fault<br>1: Alarm<br>2: Digital out only  | Default: 0<br>Range: 0 to 2                         | 225  |
| P1-14<br>(0C0D)<br>RUN | Hysteresis Level                               | Hysteresis Level  | Sets the hysteresis level used for low and high level feedback detection.  | Default: 0.0 PSI <2><br>Min.: 0.0<br>Max.: 100.0    | 226  |
| P1-15<br>(0C0E)<br>RUN | Maximum Setpoint Difference                    | Max Set Pnt Diff  | Sets the level that the difference between the setpoint and the feedback must exceed for the time set in P1-16 to trigger the drive response set in P1-17.<br>If P1-17 is set to 1 (Fault and digital out), the drive will coast to stop.<br>This function is active when the drive is running during AUTO Mode. When P1-01 is set to 3 (MEMOBUS network), the function is active on the lead drive and will stop all drives running on the network when the NMS fault occurs.<br>Setting this parameter to 0.0 disables the function. | Default: 0.0 PSI <2><br>Min.: 0.0<br>Max.: 6000.0   | 226  |
| P1-16<br>(0C0F)<br>RUN | Not Maintaining Setpoint Time                  | Not Maint SP Tm   | Sets the delay time before a “Setpoint Not Met” condition occurs. The pump protection criteria set in P1-15 must be met before the timer will start.<br>Setting P1-15 to 0.0 disables this function.   | Default: 60 s<br>Min.: 0<br>Max.: 3600              | 226  |
| P1-17<br>(0C10)        | Not Maintaining Setpoint Selection             | Not Maint SP Sel<br>0: Fault<br>1: Alarm<br>2: Digital Output       | Selects the drive response method during the “Not Maintaining Setpoint” condition.<br>0: Fault<br>1: Alarm<br>2: Digital out only  | Default: 0<br>Range: 0 to 2                         | 226  |
| P1-18<br>(0C11)        | Prime Loss Detection Method                    | Prime Loss Mthd<br>0: Current (A)<br>1: Power (kW)<br>2: Torque (%) | Determines the quantity used to determine loss of prime.<br>0: Current (A)<br>1: Power (kW)<br>2: Torque (%)   | Default: 0<br>Range: 0 to 2                         | 226  |
| P1-19<br>(0C12)<br>RUN | Prime Loss Level                               | Prime Loss Level  | Detects loss of prime in the pump when in Auto or Sleep Boost Mode.<br>When the measured quantity determined by P1-18 drops below this level for the time set in P1-20 and the output frequency is above the level set in P1-21, a “Loss of Prime” condition occurs. The drive responds to the “Loss of Prime” condition depending on the setting of P1-22, Loss of Prime Selection.   | Default: 0.0 A <2><br>Min.: 0.0<br>Max.: 1000.0     | 227  |
| P1-20<br>(0C13)<br>RUN | Loss of Prime Time                             | Prime Loss Time   | Sets the delay time before a “Loss of Prime” condition occurs. The pump protection criteria set in P1-18 and P1-19 must be met before the timer will start.  | Default: 20 s<br>Min.: 0<br>Max.: 600               | 227  |
| P1-21<br>(0C14)        | Loss of Prime Frequency                        | Prime Loss Freq   | Sets the frequency level above which the “Loss of Prime” detection is enabled when set to a value other than 0.<br>When set to 0 (default), the frequency level is determined by the smaller value between (Fmax - 1 Hz) and (d2-01 - 1 Hz).   | Default: 0.0 Hz<br>Min.: 0.0<br>Max.: [E1-04]       | 227  |
| P1-22<br>(0C15)        | Loss of Prime Selection                        | Prime Loss Sel<br>0: Fault<br>1: Alarm<br>2: Digital Output         | Sets the drive response method during the “Loss of Prime” condition.<br>0: Fault<br>1: Alarm<br>2: Digital out only  | Default: 0<br>Range: 0 to 2                         | 227  |
| P1-23<br>(0C16)        | Loss of Prime Maximum Restart Time after Fault | LOP Max Rstrt T   | Sets the time in minutes that the drive will wait before attempting another restart when the restart fails or is not attempted due to a continuing fault condition.  | Default: 0.2 min<br>Min.: 0.2<br>Max.: 6000.0       | 227  |
| P1-30<br>(0C1D)        | Low Water Digital Input Configuration          | Low Water DI Sel<br>0: Normally Open<br>1: Normally Closed          | Selects the configuration of the low water level digital input.<br>0: Normally open<br>1: Normally closed  | Default: 0<br>Range: 0, 1                           | 228  |

## B.12 P: Pump Parameters

| No. (Addr. Hex) | Name                                   | LCD Display  | Description  | Values                    | Page |
|-----------------|--|--|--|---------------------------|------|
| P1-31 (0C1E)    | High Water Digital Input Configuration | HighWater DI Sel<br>0: Normally Open<br>1: Normally Closed | Selects the configuration of the high water level digital input.<br>0: Normally open<br>1: Normally closed | Default: 0<br>Range: 0, 1 | 228  |

- <2> Unit is determined by P1-02, System Units; scaling is determined by P1-03, Feedback Device Scaling; resolution is determined by b5-39, PID System Units Display Digits.
- <3> Unit range and resolution are determined by P1-07, Minimum Pump Speed Units. Setting P1-07 to 1 (RPM) will set a default value of 1800 RPM. Setting P1-07 to 0 (Hz, default) will set a default value of 40.0 Hz.
- <4> Unit text is set by P1-18, Prime Loss Detection Method.

## ◆ P2: Pump Protection

| No. (Addr. Hex)            | Name                            | LCD Display  | Description   | Values   | Page |
|----------------------------|---------------------------------|--|---|--|------|
| P2-01 (0C64)               | Sleep Level Type                | Sleep Lvl Type<br>0: Output Frequency<br>1: Output Current<br>2: Feedback<br>3: Output Speed-RPM | 0: Output frequency<br>1: Output current<br>2: Feedback<br>3: Output speed (RPM)<br><b>Note:</b> Feedback depends on PID direction operation.   | Default: 0<br>Range: 0 to 3                          | 228  |
| P2-02 (0C65)<br><u>RUN</u> | Sleep Level                     | Sleep Level  | Sleep activates when the selected level type (P2-01 setting) reaches the programmed sleep level for the time set in P2-03. This function is active when the drive is running during AUTO Mode. When P1-01 is set to 3 (MEMOBUS network), the function is active when there is only one drive running on the network. Setting this parameter to 0.0 disables the function. | Default: 0.0 Hz<br><1><br>Min.: 0.0<br>Max.: 6000.0  | 228  |
| P2-03 (0C66)<br><u>RUN</u> | Sleep Delay Time                | Sleep Delay Time   | Sets the delay time before the drive enters Sleep Mode when the sleep level set in P2-02 is reached.  | Default: 5 s<br>Min.: 0<br>Max.: 3600                | 229  |
| P2-04 (0C67)<br><u>RUN</u> | Sleep Activate Level            | Sleep Act. Level   | Sets the level above which the output frequency must rise to activate the sleep function when P2-01, Sleep Level Type, is set to 0 (Output Frequency / Speed). Setting this parameter to 0.0 disables the function and the sleep function will activate when P2-02, Sleep Level, is reached.  | Default: 0.0 Hz<br><2><br>Min.: 0.0<br>Max.: 6000.0  | 230  |
| P2-05 (0C68)<br><u>RUN</u> | Sleep Boost Level               | Sleep Boost Lvl  | Sets the amount of boost applied to the setpoint before going to sleep. Setting this parameter to 0.0 disables the function.  | Default: 0.0 PSI<br><3><br>Min.: 0.0<br>Max.: 6000.0 | 230  |
| P2-06 (0C69)<br><u>RUN</u> | Sleep Boost Hold Time           | SleepBoost HldTm   | Sets the amount of time that the boosted pressure will be maintained before the drive goes to sleep.  | Default: 5.0 s<br>Min.: 0.5<br>Max.: 160.0           | 230  |
| P2-07 (0C6A)<br><u>RUN</u> | Sleep Boost Maximum Time        | SleepBoost MaxTm   | Sets the amount of time that the system (feedback) has to reach the boosted setpoint. The drive will go to sleep when the amount of time set in this parameter has been exceeded.   | Default: 20.0 s<br>Min.: 1.0<br>Max.: 160.0          | 230  |
| P2-08 (0C6B)<br><u>RUN</u> | Delta Sleep Feedback Drop Level | D Fb Drop Level  | If the PID Error (setpoint minus feedback) exceeds the level programmed in this parameter within the time window set in P2-09 and the output frequency is greater than the level set in P1-06, the sleep operation deactivates and the drive returns to normal operation. Setting this parameter to 0.0 disables the function.  | Default: 0.0 PSI<br><3><br>Min.: 0.0<br>Max.: 6000.0 | 230  |
| P2-09 (0C6C)<br><u>RUN</u> | Feedback Detection Drop Time    | FB Drop Det. Time  | Defines the time window in which the software monitors the feedback to detect a flow/no-flow condition.   | Default: 10.0 s<br>Min.: 0.0<br>Max.: 3600.0         | 231  |

| No. (Addr. Hex)          | Name  | LCD Display   | Description  | Values  | Page |
|--------------------------|---|---|--|---|------|
| P2-10<br>(0C6D)<br>[RUN] | Sleep Mode: Cycling Protection              | Cycle Protection  | Sets the maximum number of cycles that are allowed within the time specified in P2-11 before tripping the PoC “Pump Over Cycle” fault.<br>One cycle is defined when the drive transfers from normal operation in AUTO Mode to Sleep Mode.<br>This function is active when the drive is running during AUTO Mode. When P1-01 is set to 3 (MEMOBUS network), the function is active when there is only one drive running on the network.<br>Setting this parameter to 0 disables the function. | Default: 0<br>Min.: 0<br>Max.: 10                   | 231  |
| P2-11<br>(0C6E)<br>[RUN] | Sleep Mode: Maximum Cycling Protection Time | Max. Cycle Time   | Sets the maximum time allowed between cycles. When no cycling occurs within the programmed time, the drive will decrease the internal cycle register.  | Default: 300 s<br>Min.: 0<br>Max.: 3600             | 231  |
| P2-12<br>(0C6F)          | Over Cycling Mode                           | Over Cycle Mode<br>0: Disabled<br>1: Alarm Only<br>2: Fault<br>3: Auto SP Comp. | 0: Disabled<br>1: Alarm<br>2: Fault<br>3: Auto SP Compensation   | Default: 0<br>Range: 0 to 3                         | 231  |
| P2-13<br>(0C70)          | Setpoint Compensation                       | Setpoint Comp.  | Allows for the software to automatically compensate the setpoint in the event of excessive cycling.  | Default: 0.0 PSI<br><><br>Min.: 0.0<br>Max.: 6000.0 | 231  |
| P2-14<br>(0C71)          | Maximum Setpoint Compensation               | Max. SP Comp.   | Sets the maximum allowed setpoint compensation for over-cycling function.  | Default: 0.0 PSI<br><><br>Min.: 0.0<br>Max.: 6000.0 | 231  |
| P2-23<br>(0C7A)<br>[RUN] | Anti-No-Flow Bandwidth                      | ANF Bandwidth   | Sets the amount of PID error bandwidth used to detect the Anti-No-Flow condition.<br>Avoid setting this parameter value too high, as operation may become unstable.<br>Setting this parameter to 0.00 will disable the function.   | Default: 0.40%<br>Min.: 0.00<br>Max.: 2.00          | 231  |
| P2-24<br>(0C7B)<br>[RUN] | Anti-No-Flow Detection Time                 | ANF Det. Time   | Sets the time delay before the drive starts the increased deceleration rate after Anti-No-Flow is detected.  | Default: 10.0 s<br>Min.: 1.0<br>Max.: 60.0          | 231  |
| P2-25<br>(0C7C)<br>[RUN] | Anti-No-Flow Release Level                  | ANF Release Lvl   | Sets the amount below the setpoint which the feedback must drop to disengage the Anti-No-Flow and return to normal PID operation.  | Default: 3.0 PSI<br><><br>Min.: 0.0<br>Max.: 100.0  | 232  |

- <1> Display units vary depending on the setting for P2-01, Sleep Level Type. When P2-01 is set to 0, the display units are “Hz”; setting 1 is “A”; setting 2 is P1-02 Selection; setting 3 is “RPM”.
- <2> Display units vary depending on the setting for P2-01, Sleep Level Type. When P2-01 is set to 0, 1, or 2, the display units are “Hz”; setting 3 is “RPM”.
- <3> Unit is determined by P1-02, System Units; scaling is determined by P1-03, Feedback Device Scaling; resolution is determined by b5-39, PID System Units Display Digits.

### ◆ P4: Pump Advanced

| No. (Addr. Hex)          | Name                 | LCD Display      | Description  | Values  | Page |
|--------------------------|----------------------|------------------|--|---|------|
| P4-01<br>(0CFA)<br>[RUN] | Pre-Charge Level     | Pre-Charge Level | Runs the drive at the frequency set in P4-02.<br>The drive will exit Pre-charge when one of the following conditions occurs: <ul style="list-style-type: none"> <li>• The feedback level rises above the level set in P4-01</li> <li>• The pre-charge time set in P4-03 expires</li> <li>• The low water digital input is deactivated (#8F) (if programmed)</li> </ul> | Default: 0.0 PSI<br><><br>Min.: 0.0<br>Max.: 6000.0 | 229  |
| P4-02<br>(0CFB)<br>[RUN] | Pre-Charge Frequency | Pre-Charge Freq. | Sets the frequency reference used when the Pre-Charge function is active.  | Default: 0.0 Hz<br>Min.: 0.0<br>Max.: [E1-04]       | 229  |

## B.12 P: Pump Parameters

| No. (Addr. Hex)     | Name                                      | LCD Display   | Description   | Values   | Page |
|---------------------|---|---|---|--|------|
| P4-03<br>(0CFC)<br> | Pre-Charge Time                           | Pre-Charge Time   | Sets the time at which the drive will spend at the Pre-Charge Frequency 1 during pre-charge. Maximum pre-charge time is P4-03 + P4-07.<br>When P1-01 is set to 3 (MEMOBUS network), the function is active only on the first drive to run in the network.<br>Setting this parameter to 0.0 disables the function.   | Default: 0.0 min<br>Min.: 0.0<br>Max.: 3600.0      | 229  |
| P4-05<br>(0CFE)<br> | Pre-Charge Loss of Prime Level            | Pre-Charge LOP  | Detects loss of prime in the pump during Pre-charge 1.<br>When the measured quantity determined by P1-18 drops below this level for the time set in P1-20 and the output frequency is at the level set in P4-02, a “Loss of Prime” condition occurs.<br>The drive responds to the “Loss of Prime” condition depending on the setting of P1-22, Loss of Prime Selection. | Default: 0.0 A<br><2><br>Min.: 0.0<br>Max.: 1000.0 | 232  |
| P4-06<br>(0CFF)<br> | Pre-Charge Frequency 2                    | Pre-Charge Freq2  | Sets the frequency reference used when the Pre-Charge function 2 is active.<br>Setting this parameter to 0.0 disables the function.   | Default: 0.0 Hz<br>Min.: 0.0<br>Max.: [E1-04]      | 232  |
| P4-07<br>(0D00)<br> | Pre-Charge Time 2                         | Pre-Charge Time2  | Sets the time at which the drive will spend at the Pre-Charge frequency 2 during pre-charge. Maximum pre-charge time is P4-03 + P4-07.  | Default: 0.0 min<br>Min.: 0.0<br>Max.: 3600.0      | 232  |
| P4-08<br>(0D01)<br> | Pre-Charge Loss of Prime Level 2          | Pre-Charge LOP 2  | Detects loss of prime in the pump.<br>When the measured quantity determined by P1-18 drops below this level for the time set in P1-20 and the output frequency is at the level set in P4-06, a “Loss of Prime” condition occurs.<br>The drive responds to the “Loss of Prime” condition depending on the setting of P1-22, Loss of Prime Selection.                     | Default: 0.0 A<br><2><br>Min.: 0.0<br>Max.: 1000.0 | 232  |
| P4-10<br>(0D03)<br> | AUTO Mode Operator Run Power Down Storage | AMO PwDn-Storage<br>0: Disabled<br>1: Enabled             | Stores the run status in AUTO Mode when operating from the HOA keypad (b1-02 = 0).<br>0: Disabled<br>1: Enabled<br><br><b>WARNING! Sudden Movement Hazard. If the drive is powered down while running, it will automatically initiate an internal Run command upon power-up.</b>  | Default: 0<br>Range: 0, 1                          | 232  |
| P4-11<br>(0D04)<br> | Thrust Bearing Acceleration Time          | Thrust Acc. Time  | Sets the time at which the drive output frequency will ramp up to the reference frequency set in P4-12.   | Default: 1.0 s<br>Min.: 0.0<br>Max.: 600.0         | 232  |
| P4-12<br>(0D05)<br> | Thrust Bearing Frequency                  | Thrust Freq.  | The drive will accelerate to this frequency in the time set to P4-11. The drive will decelerate from the frequency in the time set to P4-13.  | Default: 30.0 Hz<br>Min.: 0.0<br>Max.: [E1-04]     | 233  |
| P4-13<br>(0D06)<br> | Thrust Bearing Deceleration Time          | Thrust Dec Time   | Sets the amount of time it takes to bring the drive from the Thrust Frequency set in P4-12 to stop when Thrust Mode is active.<br>When the Run command is removed while the drive is operating in Thrust Mode above the Thrust Frequency, the time set in this parameter is used when the frequency reference is at or below the thrust frequency.                      | Default: 5.0 s<br>Min.: 0.0<br>Max.: 600.0         | 233  |
| P4-17<br>(0D0A)<br> | Utility Start Delay                       | Utility Delay   | Sets the amount of time that the drive will delay starting if a Run command is present at power-up.<br>When P1-01, Pump Mode, is set to 3 (MEMOBUS network), the drive is unavailable to the network (Pump Off Network) when the function is active.<br>Setting this parameter to 0.0 disables the function.  | Default: 0.2 min<br>Min.: 0.0<br>Max.: 1000.0      | 233  |
| P4-21<br>(0D0E)     | Low City Input Select                     | Low City In Sel<br>0: Normally Open<br>1: Normally Closed | Selects the type of pressure switch connected to the “Low City Press” digital input (H1-0□ = 73).<br>0: Normally open (closed indicates the Low City Pressure condition)<br>1: Normally closed (open indicates the Low City Pressure condition)   | Default: 1<br>Range: 0, 1                          | 233  |
| P4-22<br>(0D0F)<br> | Low City On-Delay Time                    | Low City On Dly   | Sets the amount of time a Low City Pressure condition needs to be present before the drive will stop.   | Default: 10 s<br>Min.: 1<br>Max.: 1000             | 233  |
| P4-23<br>(0D10)<br> | Low City Off-Delay Time                   | Low City Off Dly  | Sets the amount of time a Low City Pressure condition needs to be absent before the drive will restart.   | Default: 5 s<br>Min.: 0<br>Max.: 1000              | 234  |



| No. (Addr. Hex)        | Name                                   | LCD Display   | Description   | Values   | Page |
|------------------------|--|---|---|--|------|
| P4-24<br>(0D11)<br>RUN | Low City Alarm Text                    | Low City Alarm Txt<br>0: Low Cty Pressure<br>1: Low Suction Pres<br>2: Low Watr in Tank | Selects the alarm message that will be displayed when a Low City Pressure condition is detected.<br>0: Low city pressure<br>1: Low suction pressure<br>2: Low water in tank   | Default: 0<br>Range: 0 to 2                          | 234  |
| P4-25<br>(0D12)        | Remote Drive Disable Selection         | Rem Drv Dis Sel<br>0: Normally Open<br>1: Normally Closed                               | Selects the type of pressure switch connected to the “Remote Drive Disable” digital input (H1-0□ = 95).<br>0: Normally open (closed indicates the Remote Drive Disable condition)<br>1: Normally closed (open indicates the Remote Drive Disable condition)   | Default: 1<br>Range: 0, 1                            | 234  |
| P4-26<br>(0D13)<br>RUN | Remote Drive Disable On-Delay          | Drv Dis On-Delay  | Sets the amount of time a Remote Drive Disable condition must be present before the drive will stop.  | Default: 0 s<br>Min.: 0<br>Max.: 1000                | 234  |
| P4-27<br>(0D14)<br>RUN | Remote Drive Disable Off-Delay         | Drv Dis OffDelay  | Sets the amount of time a Remote Drive Disable condition must be absent before the drive will run.  | Default: 0 s<br>Min.: 0<br>Max.: 1000                | 234  |
| P4-29<br>(0D16)<br>RUN | Lube Pump Message Text                 | Lube Pump Text<br>0: Lube Pump<br>1: DigitalOut Delay                                   | Selects which text is displayed when Lube Pump is active. Also changes the text for the Lube Pump Digital Output selection (H2-□□ = 8B)<br>0: Lube Pump<br>1: Digital Out Delay   | Default: 0<br>Range: 0, 1                            | 234  |
| P4-30<br>(0D17)        | Lube Pump Active During Run            | Lube Pump DurRun<br>0: Disabled<br>1: Active DuringRun                                  | When enabled, the Lube Pump digital output stays activated after the timer expires and the drive starts to run normally. The output is deactivated only when the drive stops, faults, or sleeps.<br>0: Disabled<br>1: Active During Run   | Default: 0<br>Range: 0, 1                            | 234  |
| P4-31<br>(0D18)<br>RUN | Lube Pump / Digital Output Delay Timer | Lube Pump Time  | Sets the amount of time to delay the drive output and to energize the digital output (H2-□□ = 8B) before the drive is allowed to run.<br>Setting this parameter to 0.0 disables the function.   | Default: 0.0 s<br>Min.: 0.0<br>Max.: 300.0           | 235  |
| P4-32<br>(0D19)<br>RUN | Pre-charge Level 2                     | PreCharge Level2  | For normal PID operation during Pre-charge 2, if the PID Feedback signal rises above the P4-32 level, Pre-charge 2 is cancelled and the drive resumes normal operation.<br>For inverse PID operation and during Pre-charge 2, if the PID Feedback signal goes below the P4-32 level, Pre-charge 2 is cancelled and the drive resumes normal operation.<br>When set to zero, Pre-charge 2 still runs when P4-07 is set, but uses P4-01 to determine if normal operation should resume. | Default: 0.0 PSI<br></><br>Min.: 0.0<br>Max.: 6000.0 | 235  |

<1> Unit is determined by P1-02, System Units; scaling is determined by P1-03, Feedback Device Scaling; resolution is determined by b5-39, PID System Units Display Digits.

<2> Unit text is set by P1-18, Prime Loss Detection Method.

### ◆ P5: Pump HAND Mode

| No. (Addr. Hex)        | Name                           | LCD Display  | Description   | Values                                       | Page |
|------------------------|--------------------------------|--|---|--|------|
| P5-01<br>(0D2C)<br>RUN | HAND Mode Ref Source           | Hand Mode Ref.<br>0: Analog Input<br>1: Hand Ref 1 (OPR) | Sets the HAND Mode reference.<br>0: Analog input<br><b>Note:</b> Analog input is defaulted to input A1 (0-10 V).<br>1: P5-02 (HAND reference) | Default: 1<br>Range: 0, 1                    | 235  |
| P5-02<br>(0D2D)<br>RUN | HAND Reference 1               | HAND Reference 1   | Sets the frequency reference used when HAND Mode is active and P5-01 is set to 1.   | Default: 40.0 Hz<br>Min.: 0<br>Max.: [E1-04] | 235  |
| P5-03<br>(0D2E)        | HAND/AUTO During Run Selection | HAND/AUTO @ Run<br>0: Disabled<br>1: Enabled             | Selects whether the drive will permit switching between HAND and AUTO Modes while running.<br>0: Disabled<br>1: Enabled                       | Default: 0<br>Range: 0, 1                    | 235  |
| P5-04<br>(0D2F)        | HAND Key Function Selection    | Oper HAND Key<br>0: Disabled<br>1: Enabled               | Enables and disables the HAND key on the HOA keypad.<br>0: Disabled<br>1: Enabled   | Default: 1<br>Range: 0, 1                    | 236  |

## B.12 P: Pump Parameters

| No. (Addr. Hex)                                 | Name   | LCD Display                               | Description   | Values   | Page |
|---|--|---|---|--|------|
| P5-05<br>(0D30)<br><input type="checkbox"/> RUN | HAND Reference 2                                     | HAND Reference 2                          | Sets the frequency reference used when HAND Mode 2 is active.   | Default: 0.0 Hz<br>Min.: 0.0<br>Max.: [E1-04]      | 236  |
| P5-06<br>(0D31)<br><input type="checkbox"/> RUN | HAND Ref. 1 Loss of Prime Level                      | HandRef1 LOP Lvl                          | Detects loss of prime in the pump when in HAND Mode. When the measured quantity determined by P1-18 drops below this level for the time set in P1-20 and the output frequency is at the level set in P5-02, a "Loss of Prime" condition occurs. The drive responds to the "Loss of Prime" condition depending on the setting of P1-22, Loss of Prime Selection.   | Default: 0.0 A<br><I><br>Min.: 0.0<br>Max.: 1000.0 | 236  |
| P5-07<br>(0D32)<br><input type="checkbox"/> RUN | HAND Ref. 2 Loss of Prime Level                      | HandRef2 LOP Lvl                          | Detects loss of prime in the pump when in HAND Mode 2. When the measured quantity determined by P1-18 drops below this level for the time set in P1-20 and the output frequency is at the level set in P5-05, a "Loss of Prime" condition occurs. The drive responds to the "Loss of Prime" condition depending on the setting of P1-22, Loss of Prime Selection. | Default: 0.0 A<br><I><br>Min.: 0.0<br>Max.: 1000.0 | 236  |
| P5-09<br>(0D34)                                 | HAND References Set via Motor Operated Pot Selection | HAND MOP Sel<br>0: Disabled<br>1: Enabled | Selects whether parameters P5-02 and P5-05 are changed via MOP from the home screen.<br>0: Disabled<br>1: Enabled   | Default: 0<br>Range: 0, 1                          | 236  |

<I> Unit text is set by P1-18, Prime Loss Detection Method.

## ◆ P7: Anti-Jam

| No. (Addr. Hex)                                 | Name                             | LCD Display                               | Description  | Values  | Page |
|---|----------------------------------|---|--|---|------|
| P7-01<br>(0D90)                                 | Anti-Jam Operation Selection     | Anti-Jam Sel<br>0: Disabled<br>1: Enabled | Enables and disables the anti-jam function.<br>0: Disabled<br>1: Enabled   | Default: 0<br>Range: 0, 1                       | 237  |
| P7-02<br>(0D91)<br><input type="checkbox"/> RUN | Anti-Jam Cycle Count             | AJ Cycle Count                            | Sets the maximum number of cycles that will be attempted before triggering and Anti-Jam fault.   | Default: 1<br>Min.: 1<br>Max.: 100              | 237  |
| P7-03<br>(0D92)<br><input type="checkbox"/> RUN | Anti-Jam Detection Current Level | AJ Det I @Start                           | Sets the current level at start that will trigger the anti-jam function.<br>Set as a percentage of the motor rated current.  | Default: 120%<br>Min.: 50<br>Max.: 200          | 237  |
| P7-04<br>(0D93)<br><input type="checkbox"/> RUN | Anti-Jam Detection Time at Start | AJ Det Tm@Start                           | Sets the length of time that current must rise above the level set in P7-03 to trigger the anti-jam function.  | Default: 0.3 s<br>Min.: 0.1<br>Max.: 2.0        | 237  |
| P7-05<br>(0D94)<br><input type="checkbox"/> RUN | Anti-Jam During Run Current      | AJ Det I @Run                             | Sets the current level during run that will trigger the anti-jam function.<br>Set as a percentage of motor rated current.<br>Setting this parameter to 0 will disable anti-jam during run. | Default: 0%<br>Min.: 0<br>Max.: 200             | 237  |
| P7-06<br>(0D95)<br><input type="checkbox"/> RUN | Anti-Jam During Run Time         | AJ Det Tm @Run                            | Sets the length of time that the current must rise above the level set in P7-05 to trigger the anti-jam function.<br>Restricted to simplex only.   | Default: 0.3 s<br>Min.: 0.1<br>Max.: 2.0        | 237  |
| P7-07<br>(0D96)<br><input type="checkbox"/> RUN | Anti-Jam Frequency Reference     | AJ Freq Ref                               | Sets the maximum speed allowed when the anti-jam function is active.   | Default: 25.00 Hz<br>Min.: 0.00<br>Max.: 400.00 | 237  |
| P7-08<br>(0D98)<br><input type="checkbox"/> RUN | Anti-Jam Release Time            | AJ Release Time                           | Sets the length of time that the current must fall below the level set in P7-03 to resume normal operation.  | Default: 2.0 s<br>Min.: 0.5<br>Max.: 10.0       | 237  |

## ◆ P9: Network Options

Parameters in this group are functional only when P1-01, Pump Mode, is set to 3 (MEMOBUS network).

| No. (Addr. Hex)                              | Name                  | LCD Display  | Description   | Values   | Page |
|--|-----------------------|--|---|--|------|
| P9-01 (0DF4)                                 | Lead Drive Selection  | Lead Drive Sel<br>0: Next Available<br>1: Lowest Runtime<br>2: Stop History                        | Specifies how the next lead drive is selected.<br>0: Next available<br>1: Lowest runtime<br>2: Stop history   | Default: 1<br>Range: 0 to 2                          | 238  |
| P9-02 (0DF5)                                 | Feedback Source       | Feedback Source<br>0: Analog only<br>1: Ana->Net, No Alrm<br>2: Ana->Net, Alarm<br>3: Network only | Defines which signal to use for PID feedback when P1-01, Pump Mode, is set to 3 (MEMOBUS network).<br>0: Analog only<br>1: Ana->Net, No Alrm<br>2: Ana->Net, Alarm<br>3: Network only   | Default: 0<br>Range: 0 to 3                          | 238  |
| P9-03 (0DF6)<br><input type="checkbox"/> RUN | Alternation Time      | Alternation Time   | Specifies the time for a drive to request alternation. Setting this parameter to 0 disables the function.   | Default: 24 H<br>Min.: 0<br>Max.: 1000               | 239  |
| P9-04 (0DF7)                                 | Alternation Mode      | Alternation Mode<br>0: FIFO Auto<br>1: FIFO Forced<br>2: LIFO<br>3: FIFO @ Sleep                   | Determines how alternation is performed.<br>0: FIFO auto<br>1: FIFO forced<br>2: LIFO<br>3: FIFO @sleep   | Default: 0<br>Range: 0 to 3                          | 239  |
| P9-05 (0DF8)                                 | Lag Drive Mode        | Lag Drive Mode<br>0: Fixed Speed<br>2: Turn Off<br>3: Follow Lead Spd                              | Determines the functionality of the lag drives.<br>0: Fixed speed. The drive runs at the P9-06 setting after the time set in P9-07 expires.<br>2: Turn off. The drive stops running when it switches to a lag drive after the time set in P9-07 expires.<br>3: Follow Lead Speed. The drive will follow the speed of the current lead drive, applying P9-30 gain and P9-31 bias.  | Default: 0<br>Range: 0, 2, 3                         | 239  |
| P9-06 (0DF9)<br><input type="checkbox"/> RUN | Lag Fixed Speed       | Lag Fixed Speed  | Sets the speed at which the drive will run when the drive changes from a lead to a lag and the time set in P9-07 has expired.   | Default: 55.0 Hz<br>Min.: 0.0<br>Max.: 400.0         | 239  |
| P9-07 (0DFA)<br><input type="checkbox"/> RUN | Lag Fixed Speed Delay | Lag Fix Spd Dly  | Specifies how long speed is latched before performing the function specified in P9-05 when the drive changes from a lead to a lag.  | Default: 5 s<br>Min.: 0<br>Max.: 1000                | 239  |
| P9-08 (0DFB)                                 | Add Pump Mode         | Add Pump Mode<br>0: Output Frequency<br>1: Feedback<br>2: Feedback + Fout                          | Selects the detection method for staging a new pump.<br>0: Output frequency<br>1: Feedback<br>2: Feedback + Fout  | Default: 2<br>Range: 0 to 2                          | 240  |
| P9-09 (0DFC)<br><input type="checkbox"/> RUN | Add Frequency Level   | Add Freq Lvl   | When P9-08 is set to 0, this parameter sets the level above which the output frequency needs to rise for the time set in P9-11 before the lead drive will send a request for a new lead drive via the iQPump MEMOBUS network.<br>When P9-08 is set to 2 and the delta feedback (setpoint minus feedback) has exceeded the level set in P9-10 for the time set in P9-11, this parameter sets the level above which the output frequency needs to rise before the lead drive will send a request for a new lead drive via the iQPump MEMOBUS network.                     | Default: 59.5 Hz<br>Min.: 0.0<br>Max.: 400.0         | 240  |
| P9-10 (0DFD)<br><input type="checkbox"/> RUN | Add Delta Level       | Add Delta Lvl  | When P9-08 is set to 1, this parameter sets the level above which the delta feedback (setpoint minus feedback) must rise for the time set in P9-11 before the lead drive will send a request for a new lead drive via the iQPump MEMOBUS network.<br>When P9-08 is set to 2 and the output frequency has exceeded the level set in P9-09 for the time set in P9-11, this parameter sets the level above which the delta feedback (setpoint minus feedback) needs to rise before the lead drive will send a request for a new lead drive via the iQPump MEMOBUS network. | Default: 4.0 PSI<br></><br>Min.: 0.0<br>Max.: 6000.0 | 240  |
| P9-11 (0DFE)<br><input type="checkbox"/> RUN | Add Delay Time        | Add Dly Time   | Sets the delay time before a new lead drive is added to the system.   | Default: 10 s<br>Min.: 0<br>Max.: 3600               | 240  |
| P9-12 (0DFE)                                 | Remove Pump Mode      | Remove Pump Mode<br>0: Output Frequency<br>1: Feedback<br>2: Feedback + Fout                       | Sets the detection method for de-staging to the previous lead pump.<br>0: Output frequency<br>1: Feedback<br>2: Feedback + Fout   | Default: 0<br>Range: 0 to 2                          | 240  |

## B.12 P: Pump Parameters

| No. (Addr. Hex)                                 | Name                            | LCD Display   | Description   | Values   | Page |
|---|---------------------------------|---|---|--|------|
| P9-13<br>(0E00)<br><input type="checkbox"/> RUN | Remove Frequency Level          | Remove Freq Lvl   | When P9-12 is set to 0, this parameter sets the level below which the output frequency must fall for the time set in P9-15 before the lead drive will send a request to be removed from the system via the iQPump MEMOBUS network.<br>When P9-12 is set to 2 and the delta feedback (feedback minus setpoint) has exceeded the level set in P9-14 for the time set in P9-15, this parameter sets the level below which the output frequency must fall before the lead drive will request to be removed from the system via the iQPump MEMOBUS network.                            | Default: 40.0 Hz<br>Min.: 0.0<br>Max.: 400.0           | 240  |
| P9-14<br>(0E01)<br><input type="checkbox"/> RUN | Remove Delta Level              | Remove Delta Lvl  | When P9-12 is set to 1, this parameter sets the level above which the delta feedback (feedback minus setpoint) must rise for the time set in P9-15 before the lead drive will request to be removed from the system via the iQPump MEMOBUS network.<br>When P9-12 is set to 2 and the output frequency has exceeded the level set in P9-13 for the time set in P9-15, this parameter sets the level above which the delta feedback (feedback minus setpoint) frequency must rise before the lead drive will request to be removed from the system via the iQPump MEMOBUS network. | Default: 0.0 PSI<br></><br>Min.: 0.0<br>Max.: 6000.0   | 243  |
| P9-15<br>(0E02)<br><input type="checkbox"/> RUN | Remove Delay Time               | Remove Dly Time   | Sets the delay time before the lead drive is removed from the system.   | Default: 10 s<br>Min.: 0<br>Max.: 3600                 | 241  |
| P9-16<br>(0E03)<br><input type="checkbox"/> RUN | Stabilization Time              | Stabilize Time  | Sets the time used to stabilize the system when a pump is staged or de-staged.<br>Lead/lag control and pump protection are suspended during this time.  | Default: 3 s<br>Min.: 0<br>Max.: 3600                  | 241  |
| P9-17<br>(0E04)<br><input type="checkbox"/> RUN | Setpoint Modifier               | Set-pt Modifier   | Sets the value by which the system setpoint is incremented depending on the number of pumps that are running.<br>Pump 1: Setpoint<br>Pump 2: Setpoint + ((X-1) (P9-17))   | Default: 0.0 PSI<br></><br>Min.: -999.9<br>Max.: 999.9 | 241  |
| P9-18<br>(0E05)<br><input type="checkbox"/> RUN | High Feedback Quick De-Stage    | High FB De-stage  | Sets the feedback level that will trigger a quick de-stage. Set as a percentage of the P1-11 value.<br>The quick de-stage ignores parameters P9-12 to P9-15 and uses an internal 2 second delay.<br>Setting this parameter to 0.0 disables the feature.   | Default: 97.0%<br>Min.: 0.0<br>Max.: 100.0             | 241  |
| P9-19<br>(0E06)<br><input type="checkbox"/> RUN | Alternation Unit                | Alternation Unit<br>0: Hours (H)<br>1: Minutes (min)                                      | Sets the units used in P9-03.<br>0: Hours (H)<br>1: Minutes (min)   | Default: 0<br>Range: 0, 1                              | 241  |
| P9-20<br>(0E07)                                 | Allow Network Run               | Allow Net Run<br>0: Always<br>1: First/Altrnation<br>2: First Only<br>3: Alternation Only | Specifies when a network Run command is allowed.<br>0: Always<br>1: First/alternation<br>2: First only<br>3: Alternation only   | Default: 0<br>Range: 0 to 3                            | 241  |
| P9-21<br>(0E08)<br><input type="checkbox"/> RUN | Run Priority                    | Run Priority  | Sets the lead drive selection priority overriding the P9-01 selection. Lower value = Higher priority.<br>If multiple drives have the lowest P9-21 value, then P9-01 determines which drive becomes the lead.  | Default: 8<br>Min.: 1<br>Max.: 16                      | 242  |
| P9-22<br>(0E09)<br><input type="checkbox"/> RUN | System Fault Retry              | System Flt Retry  | Sets the number of times that the iQPump MEMOBUS network will allow automatic restarts of system faults.<br>The drive uses L5-04, Fault Reset Interval Time, to determine when to attempt a system fault restart.<br>Set this parameter to the same value for all drives on the network.  | Default: 5<br>Min.: 0<br>Max.: 10                      | 242  |
| P9-23<br>(0E0A)                                 | Maximum Number of Running Pumps | MaxPumps Running  | Sets the maximum number of pumps that can run on the system.  | Default: 4<br>Min.: 1<br>Max.: 4                       | 242  |
| P9-24<br>(0E0B)<br><input type="checkbox"/> RUN | Lead Swap at Sleep              | Lead Swap @Sleep  | Sets the length of time for which the lead drive will be in Sleep Mode before this drive will request a swap when there is another drive available with a lower P9-21 setting.<br>Setting this parameter to 0 will disable the function.  | Default: 0 s<br>Min.: 0<br>Max.: 7200                  | 242  |
| P9-25<br>(0E0C)                                 | Highest Node Address            | Highest Node Adr  | Sets the highest possible node address in the MEMOBUS network.<br>For optimal network performance, set the serial communication address H5-01 beginning with 01h consecutively up to the last drive and then set this parameter to that H5-01 address.  | Default: 4<br>Min.: 2<br>Max.: 4                       | 243  |

| No. (Addr. Hex)          | Name                                       | LCD Display  | Description  | Values   | Page |
|--------------------------|--|--|--|--|------|
| P9-26<br>(0E0D)          | Master Time-out                            | Master Time-out  | Sets the minimum amount of time that the slave drives will wait for a message from the master before performing the action set in P9-27.   | Default: 4.0 s<br>Min.: 1.0<br>Max.: 10.0            | 243  |
| P9-27<br>(0E0E)          | Network Recovery                           | Network Recovery<br>0: Automatic<br>1: Slave/Resume<br>2: Slave/Stop<br>3: Fault MSL | Determines the drive response when no messages are received from the master for the time set in P9-26.<br>0: Automatic. The drive will attempt to assume master functionality.<br>1: Slave/Resume. The drive will continue running when the master is lost and will wait for a master to come online.<br>2: Slave/Stop. The drive will stop running when the master is lost and will wait for a master to come online.<br>3: Fault MSL. Fault the drive with an MSL (Master Lost). | Default: 0<br>Range: 0 to 3                          | 243  |
| P9-28<br>(0E0F)          | NETSCAN Alarm Time                         | NETSCAN AlrmTime   | Sets the amount of time that the slave drives will wait for a message from the master before displaying a NETSCAN alarm.   | Default: 2.0 s<br>Min.: 1.0<br>Max.: 10.0            | 243  |
| P9-29<br>(0E10)<br>[RUN] | Net Start Delay                            | Net Start Delay  | Sets the amount of time that the network will wait before selecting and starting the lead drive after the first drive on the network has been put on AUTO Mode.  | Default: 2.0 s<br>Min.: 0.0<br>Max.: 60.0            | 243  |
| P9-30<br>(0E11)<br>[RUN] | Lag Drive Speed Follower Gain              | Lag Followr Gain   | Sets the gain to be applied to the speed of the current lead drive when P9-05 is set to 3. The bias to be applied is set in P9-31.   | Default: 100.0%<br>Min.: 0.0<br>Max.: 300.0          | 243  |
| P9-31<br>(0E12)<br>[RUN] | Lag Drive Speed Follower Bias              | Lag Followr Bias   | Sets the bias to be applied to the speed of the current lead drive when P9-05 is set to 3. The gain to be applied is set in P9-30.   | Default: 0.00 Hz<br>Min.: -60.0<br>Max.: 60.0        | 243  |
| P9-32<br>(0E13)<br>[RUN] | Lag Follower Deceleration Time             | Lag Followr Dcel   | Sets the deceleration time when the P9-33 timer is running and the drive is running as Lag Drive Speed Follower (P9-05 is set to 3).   | Default: 60.0 s<br>Min.: 0.0<br>Max.: 1000.0         | 244  |
| P9-33<br>(0E14)<br>[RUN] | Lag Follower Deceleration Time Active Time | Lag Followr Dtim   | Sets the time during which the deceleration time set in P9-32 is effective. The drive will use the standard deceleration rate when it expires.<br>Setting this parameter to 0.0 disables the function.   | Default: 0.0 s<br>Min.: 0.0<br>Max.: 3600.0          | 244  |
| P9-34<br>(0E15)<br>[RUN] | Low Feedback Quick De-Stage                | Low FB De-stage  | Sets the low feedback level that will trigger a quick de-stage. The quick de-stage ignores parameters P9-12 and P9-15 and only uses an internal 2 second delay.<br>Setting this parameter to 0.0 disables the function.  | Default: 0.0 PSI<br></><br>Min.: 0.0<br>Max.: 6000.0 | 244  |
| P9-99<br>(0E56)          | Network Compatibility Selection            | Network Comp Sel<br>0: A-Ver: 30034<br>1: B-Ver: 30035/36<br>2: iQ SmartNetwork      | Determines the communication compatibility for the iQPump MEMOBUS network.<br>0: A-Ver: 30034<br>1: B-Ver: 30035/36<br>2: iQ SmartNetwork  | Default: 2<br>Range: 0 to 2                          | 244  |

<1> Unit is determined by P1-02, System Units; scaling is determined by P1-03, Feedback Device Scaling; resolution is determined by b5-39, PID System Units Display Digits.

## B.13 Q: PID Controller Parameters

### ◆ Q1: Preset Setpoint

| No. (Addr. Hex)                                       | Name                                    | LCD Display                               | Description  | Values   | Page |
|---|---|---|--|--|------|
| Q1-01<br>(0E58)<br><input type="button" value="RUN"/> | PID Controller Setpoint 1               | Setpoint 1                                | Sets the PID Setpoint when b1-01 is set to 0.  | Default: 0.0<br>Min.: 0.0<br>Max.: 6000.0<br><1> | 245  |
| Q1-02<br>(0E59)<br><input type="button" value="RUN"/> | PID Controller Setpoint 2               | Setpoint 2                                | Sets the PID Setpoint when the "Multi Setpoint 1" or "Alternate Multi Setpoint 1" multi-function digital input is closed.                          | Default: 0.0<br>Min.: 0.0<br>Max.: 6000.0<br><1> | 245  |
| Q1-03<br>(0E5A)<br><input type="button" value="RUN"/> | PID Controller Setpoint 3               | Setpoint 3                                | Sets the PID Setpoint when the "Multi Setpoint 2" or "Alternate Multi Setpoint 2" digital input is closed.   | Default: 0.0<br>Min.: 0.0<br>Max.: 6000.0<br><1> | 245  |
| Q1-04<br>(0E5B)<br><input type="button" value="RUN"/> | PID Controller Setpoint 4               | Setpoint 4                                | Sets the PID Setpoint when the "Multi Setpoint 1" and "Multi Setpoint 2" or "Alternate Multi Setpoint 3" multi-function digital inputs are closed. | Default: 0.0<br>Min.: 0.0<br>Max.: 6000.0<br><1> | 245  |
| Q1-09<br>(0E60)                                       | PID Setpoint Set via Motor Operated Pot | Setpoint MOP<br>0: Disabled<br>1: Enabled | Selects whether parameters Q1-01 to Q1-04 are changed via MOP from the home screen.<br>0: Disabled<br>1: Enabled                                   | Default: 0<br>Range: 0, 1                        | 245  |

<1> Unit is determined by P1-02, System Units; scaling is determined by P1-03, Feedback Device Scaling; resolution is determined by b5-39, PID System Units Display Digits.

### ◆ Q3: Output Current Limit

| No. (Addr. Hex) | Name                        | LCD Display  | Description  | Values                                      | Page |
|-----------------|-----------------------------|--|--|---|------|
| Q3-01<br>(0EBC) | Output Current Limit Select | Current Lim Sel<br>0: Disabled<br>1: Enabled                       | Enables and disables the output current regulator.<br>0: Disabled<br>1: Enabled                                    | Default: 0<br>Range: 0, 1                   | 245  |
| Q3-02<br>(0EBD) | Current Limit               | Current Limit  | Sets the current limit. Value is internally limited to 300% of the drive rated current.                            | Default: 0.0 A<br>Min.: 0.0<br>Max.: 1000.0 | 245  |
| Q3-10<br>(0EC5) | Ripple Regulator Selection  | Ripple Reg Sel<br>0: Disabled<br>1: Enabled<br>2: Enabled(Reactor) | Enables and disables the single phase ripple regulator.<br>0: Disabled<br>1: Enabled<br>2: Enabled w/ Line Reactor | Default: 1<br>Range: 0 to 2                 | 245  |
| Q3-11<br>(0EC6) | Ripple Regulator Setpoint   | Ripple Reg S.P.  | Set as a percentage of the maximum amount of ripple allowed before triggering an input phase loss fault.           | Default: 95.0%<br>Min.: 0.0<br>Max.: 200.0  | 245  |

## B.14 S: Special Application

### ◆ S6: Protection

| No.<br>(Addr.<br>Hex) | Name                                      | LCD Display   | Description  | Values   | Page |
|-----------------------|---|---|--|--|------|
| S6-01<br>(3236)       | Emergency Override<br>Speed               | E Override Speed  | Sets the speed command used in emergency override mode<br>when S6-02 = 0.                            | Default: 0.00 Hz<br>Min.: 0.00<br>Max.: 240.00 | 246  |
| S6-02<br>(3237)       | Emergency Override<br>Reference Selection | E OverrideRefSel<br>0: Use S6-01 Ref<br>1: Use Freq Ref | Selects the emergency override speed source.<br>0: Use S6-01 Reference<br>1: Use Frequency Reference | Default: 0<br>Range: 0, 1                      | 246  |

## B.15 T: Motor Tuning

Enter data into the following parameters to tune the motor and drive for optimal performance

### ◆ T1: Induction Motor Auto-Tuning

| No. (Addr. Hex) | Name                       | LCD Display                           | Description  | Values  | Page |
|-----------------|----------------------------|---------------------------------------|--|---|------|
| T1-01 (0701)    | Auto-Tuning Mode Selection | Tuning Mode Sel<br>2: Term Resistance | 2: Stationary Auto-Tuning for Line-to-Line Resistance  | Default: 2<br>Range: 2  | 102  |
| T1-02 (0702)    | Motor Rated Power          | Mtr Rated Power                       | Sets the motor rated power as specified on the motor nameplate.<br><b>Note:</b> Use the following formula to convert horsepower into kilowatts:<br>1HP = 0.746 kW. | Default: </><br>Min.: 0.03 kW<br>Max.: 650.00 kW                                      | 103  |
| T1-04 (0704)    | Motor Rated Current        | Rated Current                         | Sets the motor rated current as specified on the motor nameplate.  | Default: </><br>Min.: 10% of drive rated current<br>Max.: 200% of drive rated current | 103  |

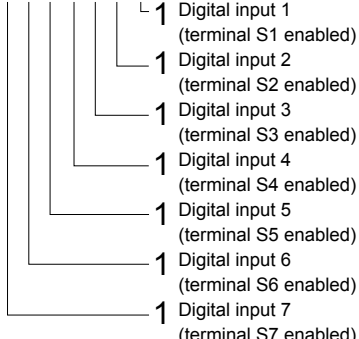
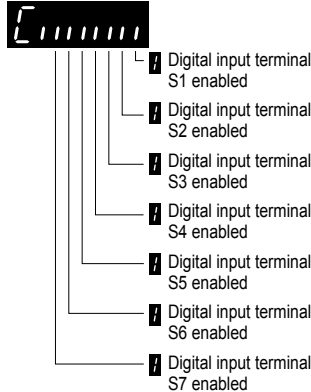
<1> Default setting is dependent on parameter o2-04, Drive Model Selection.



## B.16 U: Monitors

Monitor parameters allow the user to view drive status, fault information, and other information about drive operation.

### ◆ U1: Operation Status Monitors

| No. (Addr. Hex) | Name                     | LCD Display    | Description   | Analog Output Level                      | Unit    |
|-----------------|--------------------------|----------------|---|--|---------|
| U1-01 (0040)    | Frequency Reference      | Frequency Ref  | Monitors the frequency reference. Display units are determined by o1-03.  | 10 V: Max frequency                      | 0.01 Hz |
| U1-02 (0041)    | Output Frequency         | Output Freq    | Displays the output frequency. Display units are determined by o1-03.   | 10 V: Max frequency                      | 0.01 Hz |
| U1-03 (0042)    | Output Current           | Output Current | Displays the output current.  | 10 V: Drive rated current                | <▷ <◁   |
| U1-04 (0043)    | Control Method           | Control Method | 0: V/f Control  | No signal output available               | –       |
| U1-06 (0045)    | Output Voltage Reference | Output Voltage | Displays the output voltage.  | 10 V: 200 Vrms <▷ <◁                     | 0.1 Vac |
| U1-07 (0046)    | DC Bus Voltage           | DC Bus Voltage | Displays the DC bus voltage.  | 10 V: 400 V <▷ <◁                        | 1 Vdc   |
| U1-08 (0047)    | Output Power             | Output kWatts  | Displays the output power (this value is calculated internally).  | 10 V: Drive capacity (motor capacity) kW | <▷ <◁   |
| U1-10 (0049)    | Input Terminal Status    | Input Term Sts | <p>Displays the input terminal status.</p> <p><b>U1 - 10= 00000000</b></p>  <ul style="list-style-type: none"> <li>1 Digital input 1 (terminal S1 enabled)</li> <li>1 Digital input 2 (terminal S2 enabled)</li> <li>1 Digital input 3 (terminal S3 enabled)</li> <li>1 Digital input 4 (terminal S4 enabled)</li> <li>1 Digital input 5 (terminal S5 enabled)</li> <li>1 Digital input 6 (terminal S6 enabled)</li> <li>1 Digital input 7 (terminal S7 enabled)</li> </ul>  | No signal output available               | –       |

## B.16 U: Monitors

| No. (Addr. Hex) | Name                                | LCD Display     | Description   | Analog Output Level        | Unit    |
|-----------------|-------------------------------------|-----------------|---|----------------------------|---------|
| U1-11 (004A)    | Output Terminal Status              | Output Term Sts | <p>Displays the output terminal status.</p> <p><b>U1 - 11 = 00000000</b></p> <p>1 Multi-Function Digital Output (fault) (terminal MA/MB-MC)<br/> 1 Multi-Function Digital Output 1 (terminal P1) enabled<br/> 1 Multi-Function Digital Output 2 (terminal P2) enabled</p>                   | No signal output available | —       |
| U1-12 (004B)    | Drive Status                        | Int Ctl Sts 1   | <p>Verifies the drive operation status.</p> <p><b>U1 - 12 = 00000000</b></p> <p>1 During run<br/> 1 During zero-speed<br/> 1 During REV<br/> 1 During fault reset signal input<br/> 1 During speed agree<br/> 1 Drive ready<br/> 1 During alarm detection<br/> 1 During fault detection</p> | No signal output available | —       |
| U1-13 (004E)    | Terminal A1 Input Level             | Term A1 Level   | Displays the signal level to analog input terminal A1.  | 10 V: 100%                 | 0.1%    |
| U1-14 (004F)    | Terminal A2 Input Level             | Term A2 Level   | Displays the signal level to analog input terminal A2.  | 10 V: 100%                 | 0.1%    |
| U1-16 (0053)    | Output Frequency after Soft Starter | SFS Output      | Displays output frequency with ramp time and S-curves. Units determined by o1-03.   | 10 V: Max frequency        | 0.01 Hz |
| U1-18 (0061)    | oPE Fault Parameter                 | OPE Error Code  | Displays the parameter number that caused the oPE02 operation error.  | No signal output available | —       |

| No. (Addr. Hex) | Name                        | LCD Display      | Description   | Analog Output Level        | Unit          |
|-----------------|-----------------------------|------------------|---|----------------------------|---------------|
| U1-19 (0066)    | MEMOBUS/Modbus Error Code   | Transmit Err     | <p>Displays the contents of a MEMOBUS/Modbus error.</p> <p><b>U1 - 19=00000000</b></p>  | No signal output available | -             |
| U1-24 (007D)    | Input Pulse Monitor         | Term RP Inp Freq | Displays the frequency to pulse train input terminal RP.  | Determined by H6-02        | 1 Hz          |
| U1-25 (004D)    | Software Number (Flash)     | CPU 1 SW Number  | FLASH ID  | No signal output available | -             |
| U1-26 (005B)    | Software No. (ROM)          | CPU 2 SW Number  | ROM ID  | No signal output available | -             |
| U1-75 (0851)    | Time-Hour/Minute            | Time Hr Min HHMM | Displays the current time (Hours and Minutes).  | No signal output available | -             |
| U1-76 (0852)    | Date – Year                 | Date Year        | Displays the current year.  | No signal output available | -             |
| U1-77 (0853)    | Date – Month/Day            | Date Mo Day MMDD | Displays the current date (Month and Date).   | No signal output available | -             |
| U1-78 (0854)    | Date – Week Day             | Date Week        | <p>Displays the current day of the week.</p> <p>0: Sunday<br/>1: Monday<br/>2: Tuesday<br/>3: Wednesday<br/>4: Thursday<br/>5: Friday<br/>6: Saturday</p> | No signal output available | -             |
| U1-90 (0BA5)    | Pump Setpoint               | Pump Setpoint    | Displays the PID Setpoint.  | No signal output available | dep. on P1-02 |
| U1-91 (0BA6)    | Pump Feedback               | Pump Feedback    | Displays the PID Feedback.  | No signal output available | dep. on P1-02 |
| U1-93 (0BA8)    | Total Setpoint Compensation | Total SP Comp.   | Displays the total absolute Setpoint Compensation.  | No signal output available | dep. on P1-02 |
| U1-94 (0BA9)    | Motor Speed                 | Motor Speed      | Displays the absolute value of the output frequency (U1-02) converted to RPM.   | No signal output available | 1 RPM         |
| U1-99 (0BAE)    | Anti-No-Flow Timer          | ANF Timer        | The Anti-No-Flow reduces the output frequency when this value reaches the P2-24 setting.  | No signal output available | 0.1 s         |

- <1> Display is in the following units:  
 BV0006 to BV0018, 2V0006 to 2V0040, and 4V0002 to 4V0023: 0.01 A units.  
 2V0056 to 2V0069 and 4V0031 to 4V0038: 0.1 A units.
- <2> When reading the value of this monitor via MEMOBUS/Modbus, a value of 8192 is equal to 100% of the drive rated output current.
- <3> Values shown are specific to 200 V class drives. Double the value for 400 V class drives.
- <4> This value has two decimal places (0.01 kW) if the drive is set for a maximum applicable motor capacity up to and including 11 kW, and one decimal place (0.1 kW) if the maximum applicable motor capacity is higher than 11 kW.

**◆ U2: Fault Trace**

| No. (Addr. Hex) | Name   | LCD Display      | Description  | Analog Output Level        | Unit    |
|-----------------|--|------------------|--|----------------------------|---------|
| U2-01 (0080)    | Current Fault                                  | Current Fault    | Displays the current fault.  | No signal output available | –       |
| U2-02 (0081)    | Previous Fault                                 | Last Fault       | Displays the previous fault.   | No signal output available | –       |
| U2-03 (0082)    | Frequency Reference at Previous Fault          | Frequency Ref    | Displays the frequency reference at the previous fault.  | No signal output available | 0.01 Hz |
| U2-04 (0083)    | Output Frequency at Previous Fault             | Output Freq      | Displays the output frequency at the previous fault.   | No signal output available | 0.01 Hz |
| U2-05 (0084)    | Output Current at Previous Fault               | Output Current   | Displays the output current at the previous fault.   | No signal output available | <1> <2> |
| U2-07 (0086)    | Output Voltage at Previous Fault               | Output Voltage   | Displays the output voltage at the previous fault.   | No signal output available | 0.1 Vac |
| U2-08 (0087)    | DC Bus Voltage at Previous Fault               | DC Bus Voltage   | Displays the DC bus voltage at the previous fault.   | No signal output available | 1 Vdc   |
| U2-09 (0088)    | Output Power at Previous Fault                 | Output kWatts    | Displays the output power at the previous fault.   | No signal output available | 0.1 kW  |
| U2-11 (008A)    | Input Terminal Status at Previous Fault        | Input Term Sts   | Displays the input terminal status at the previous fault. Displayed as in U1-10.                               | No signal output available | –       |
| U2-12 (008B)    | Output Terminal Status at Previous Fault       | Output Term Sts  | Displays the output status at the previous fault. Displays the same status displayed in U1-11.                 | No signal output available | –       |
| U2-13 (008C)    | Drive Operation Status at Previous Fault       | Inverter Status  | Displays the operation status of the drive at the previous fault. Displays the same status displayed in U1-12. | No signal output available | –       |
| U2-14 (008D)    | Cumulative Operation Time at Previous Fault    | Elapsed time     | Displays the cumulative operation time at the previous fault.  | No signal output available | 1 h     |
| U2-15 (07E0)    | Soft Starter Speed Reference at Previous Fault | SFS Output       | Displays the speed reference for the soft starter at the previous fault.                                       | No signal output available | 0.01 Hz |
| U2-16 (07E1)    | Motor q-Axis Current at Previous Fault         | Motor Iq Current | Displays the q-axis current for the motor at the previous fault.   | No signal output available | 0.10%   |
| U2-30 (3008)    | Date Year at Previous Fault                    | Date Year YYYY   | Displays the year when the most recent fault occurred.   | No signal output available | –       |
| U2-31 (3009)    | Date Month and Day at Previous Fault           | Date Mo Day MMDD | Displays the date and day when the most recent fault occurred.   | No signal output available | –       |
| U2-32 (300A)    | Time Hours and Minutes at Previous Fault       | Time Hr Min HHMM | Displays the time when the most recent fault occurred.   | No signal output available | –       |

<1> Display is in the following units:  
 BV0006 to BV0018, 2V0006 to 2V0040, and 4V0002 to 4V0023: 0.01 A units.  
 2V0056 to 2V0069 and 4V0031 to 4V0038: 0.1 A units.

<2> When reading the value of this monitor via MEMOBUS/Modbus, a value of 8192 is equal to 100% of the drive rated output current.

**◆ U3: Fault History**

| No. (Addr. Hex)                          | Name                           | LCD Display     | Description   | Analog Output Level        | Unit |
|--|--------------------------------|-----------------|---|----------------------------|------|
| U3-01 to U3-04 (90 to 93 (0800 to 0803)) | First to 4th Most Recent Fault | Fault Message □ | Displays the first to the fourth most recent faults.  | No signal output available | –    |
| U3-05 to U3-10 (0804 to 0809)            | 5th to 10th Most Recent Fault  | Fault Message □ | Displays the fifth to the tenth most recent faults. After ten faults, data for the oldest fault is deleted. The most recent fault appears in U3-01, with the next most recent fault appearing in U3-02. The data is moved to the next monitor parameter each time a fault occurs. | No signal output available | –    |

| No. (Addr. Hex)                          | Name   | LCD Display    | Description  | Analog Output Level        | Unit |
|--|--|----------------|--|----------------------------|------|
| U3-11 to U3-14 (94 to 97 (080A to 080D)) | Cumulative Operation Time at 1st to 4th Most Recent Fault  | Elapsed Time □ | Displays the cumulative operation time when the first to the fourth most recent faults occurred. | No signal output available | 1 h  |
| U3-15 to U3-20 (080E to 0813)            | Cumulative Operation Time at 5th to 10th Most Recent Fault | Elapsed Time □ | Displays the cumulative operation time when the fifth to the tenth most recent faults occurred.  | No signal output available | 1 h  |
| U3-21 (300B)                             | Date Year at Most Recent Fault                             | Fault 1 YYYY   | Displays the year when the most recent fault occurred.   | No signal output available | –    |
| U3-22 (300C)                             | Date Month and Day at Most Recent Fault                    | Fault 1 MMDD   | Displays the date and day when the most recent faults occurred.                                  | No signal output available | –    |
| U3-23 (300D)                             | Time Hours and Minutes at Most Recent Fault                | Fault 1 HHMM   | Displays the time when the most recent fault occurred.   | No signal output available | –    |
| U3-24 (300E)                             | Date Year at 2nd Most Recent Fault                         | Fault 2 YYYY   | Displays the year when the second most recent fault occurred.                                    | No signal output available | –    |
| U3-25 (300F)                             | Date Month and Day at 2nd Most Recent Fault                | Fault 2 MMDD   | Displays the date and day when the second most recent fault occurred.                            | No signal output available | –    |
| U3-26 (3010)                             | Time Hours and Minutes at 2nd Most Recent Fault            | Fault 2 HHMM   | Displays the time when the second most recent fault occurred.                                    | No signal output available | –    |
| U3-27 (3011)                             | Date Year at 3rd Most Recent Fault                         | Fault 3 YYYY   | Displays the year when the most third recent fault occurred.                                     | No signal output available | –    |
| U3-28 (3012)                             | Date Month and Day at 3rd Most Recent Fault                | Fault 3 MMDD   | Displays the date and day when the third most recent fault occurred.                             | No signal output available | –    |
| U3-29 (3013)                             | Time Hours and Minutes at 3rd Most Recent Fault            | Fault 3 HHMM   | Displays the time when the third most recent fault occurred.                                     | No signal output available | –    |
| U3-30 (3014)                             | Date Year at 4th Most Recent Fault                         | Fault 4 YYYY   | Displays the year when the fourth most recent fault occurred.                                    | No signal output available | –    |
| U3-31 (3015)                             | Date Month and Day at 4th Most Recent Fault                | Fault 4 MMDD   | Displays the date and day when the fourth most recent fault occurred.                            | No signal output available | –    |
| U3-32 (3016)                             | Time Hours and Minutes at 4th Most Recent Fault            | Fault 4 HHMM   | Displays the time when the fourth most recent fault occurred.                                    | No signal output available | –    |
| U3-33 (3017)                             | Date Year at 5th Most Recent Fault                         | Fault 5 YYYY   | Displays the year when the fifth most recent fault occurred.                                     | No signal output available | –    |
| U3-34 (3018)                             | Date Month and Day at 5th Most Recent Fault                | Fault 5 MMDD   | Displays the date and day when the fifth most recent fault occurred.                             | No signal output available | –    |
| U3-35 (3019)                             | Time Hours and Minutes at 5th Most Recent Fault            | Fault 5 HHMM   | Displays the time when the fifth most recent fault occurred.                                     | No signal output available | –    |
| U3-36 (301A)                             | Date Year at 6th Most Recent Fault                         | Fault 6 YYYY   | Displays the year when the sixth most recent fault occurred.                                     | No signal output available | –    |
| U3-37 (301B)                             | Date Month and Day at 6th Most Recent Fault                | Fault 6 MMDD   | Displays the date and day when the sixth most recent fault occurred.                             | No signal output available | –    |
| U3-38 (301C)                             | Time Hours and Minutes at 6th Most Recent Fault            | Fault 6 HHMM   | Displays the time when the sixth most recent fault occurred.                                     | No signal output available | –    |
| U3-39 (301D)                             | Date Year at 7th Most Recent Fault                         | Fault 7 YYYY   | Displays the year when the seventh most recent fault occurred.                                   | No signal output available | –    |
| U3-40 (301E)                             | Date Month and Day at 7th Most Recent Fault                | Fault 7 MMDD   | Displays the date and day when the seventh most recent fault occurred.                           | No signal output available | –    |
| U3-41 (301F)                             | Time Hours and Minutes at 7th Most Recent Fault            | Fault 7 HHMM   | Displays the time when the seventh most recent fault occurred.                                   | No signal output available | –    |
| U3-42 (3020)                             | Date Year at 8th Most Recent Fault                         | Fault 8 YYYY   | Displays the year when the eighth most recent fault occurred.                                    | No signal output available | –    |

## B.16 U: Monitors

| No. (Addr. Hex) | Name  | LCD Display   | Description   | Analog Output Level        | Unit |
|-----------------|---|---------------|---|----------------------------|------|
| U3-43 (3021)    | Date Month and Day 8th at Most Recent Fault     | Fault 8 MMDD  | Displays the date and day when the eighth most recent fault occurred. | No signal output available | –    |
| U3-44 (3022)    | Time Hours and Minutes at 8th Most Recent Fault | Fault 8 HHMM  | Displays the time when the eighth most recent fault occurred.         | No signal output available | –    |
| U3-45 (3023)    | Date Year at 9th Most Recent Fault              | Fault 9 YYYY  | Displays the year when the ninth most recent fault occurred.          | No signal output available | –    |
| U3-46 (3024)    | Date Month and Day at 9th Most Recent Fault     | Fault 9 MMDD  | Displays the date and day when the ninth most recent fault occurred.  | No signal output available | –    |
| U3-47 (3025)    | Time Hours and Minutes at 9th Most Recent Fault | Fault 9 HHMM  | Displays the time when the ninth most recent fault occurred.          | No signal output available | –    |
| U3-48 (3026)    | Date Year at 10th Most Recent Fault             | Fault 10 YYYY | Displays the year when the tenth most recent fault occurred.          | No signal output available | –    |
| U3-49 (3027)    | Date Month and Day at 10th Most Recent Fault    | Fault 10 MMDD | Displays the date and day when the tenth most recent fault occurred.  | No signal output available | –    |
| U3-50 (3028)    | Time Hours and Minutes at 10th Most Recent      | Fault 10 HHMM | Displays the time when the tenth most recent fault occurred.          | No signal output available | –    |

## ◆ U4: Maintenance Monitors

| No. (Addr. Hex) | Name                                 | LCD Display      | Description   | Analog Output Level        | Unit   |
|-----------------|--------------------------------------|------------------|---|----------------------------|--------|
| U4-01 (004C) <> | Cumulative Operation Time            | Drv Elapsed Time | Displays the cumulative operation time of the drive. The value for the cumulative operation time counter can be reset in parameter o4-01. Use parameter o4-02 to determine if the operation time should start as soon as the power is switched on or only while the Run command is present. The maximum number displayed is 99999, after which the value is reset to 0. | No signal output available | 1 h    |
| U4-02 (0075)    | Number of Run Commands               | RUN Cmd Counter  | Displays the number of times the Run command is entered. Reset the number of Run commands using parameter o4-13. This value will reset to 0 and start counting again after reaching 65535.  | No signal output available | 1 Time |
| U4-03 (0067) <> | Cooling Fan Operation Time           | Fan Elapsed Time | Displays the cumulative operation time of the cooling fan. The default value for the fan operation time is reset in parameter o4-03. This value will reset to 0 and start counting again after reaching 99999.  | No signal output available | 1 h    |
| U4-04 (007E)    | Cooling Fan Maintenance              | Fan Life Mon     | Displays main cooling fan usage time as a percentage of its expected performance life. Parameter o4-03 can be used to reset this monitor. Replace the fan when this monitor reaches 90%.  | No signal output available | 1%     |
| U4-05 (007C)    | Capacitor Maintenance                | Cap Life Mon     | Displays main circuit capacitor usage time as a percentage of their expected performance life. Parameter o4-05 can be used to reset this monitor. Replace the capacitor when this monitor reaches 90%.  | No signal output available | 1%     |
| U4-06 (07D6)    | Soft Charge Bypass Relay Maintenance | ChgCirc Life Mon | Displays the soft charge bypass relay maintenance time as a percentage of its estimated performance life. Parameter o4-07 can be used to reset this monitor. Replace the soft charge bypass relay when this monitor reaches 90%.  | No signal output available | 1%     |
| U4-07 (07D7)    | IGBT Maintenance                     | IGBT Life Mon    | Displays IGBT usage time as a percentage of the expected performance life. Parameter o4-09 can be used to reset this monitor. Replace the IGBT when this monitor reaches 90%.   | No signal output available | 1%     |
| U4-08 (0068)    | Heatsink Temperature                 | Heatsink Temp    | Displays the heatsink temperature.  | 10 V: 100 °C               | 1 °C   |
| U4-09 (003C)    | LED Check                            | LED Oper Check   | Lights all segments of the LED to verify that the display is working properly. Press the ENTER key to turn the LEDs on and press ESC to turn the LEDs off.  | No signal output available | –      |

| No. (Addr. Hex) | Name  | LCD Display      | Description   | Analog Output Level        | Unit                     |
|-----------------|---|------------------|---|----------------------------|--------------------------|
| U4-10 (005C)    | kWh, Lower 4 Digits                           | kWh Lower 4 dig  | Monitors the drive output power usage (or consumption). The value is shown as a 9-digit number displayed across two monitor parameters, U4-10 and U4-11.<br>Example:<br>12345678.9 kWh is displayed as:<br>U4-10: 678.9 kWh<br>U4-11: 12345 MWh   | No signal output available | 1 kWh                    |
| U4-11 (005D)    | kWh, Upper 5 Digits                           | kWh Upper 5 dig  |   | No signal output available | 1 MWh                    |
| U4-13 (07CF)    | Peak Hold Current                             | Current PeakHold | Displays the highest current value that occurred during run.  | No signal output available | 0.01 A<br><3> <4><br><5> |
| U4-14 (07D0)    | Peak Hold Output Frequency                    | Freq@ I PeakHold | Displays the output frequency when the current value shown in U4-13 occurred.   | No signal output available | 0.01 Hz                  |
| U4-16 (07D8)    | Motor Overload Estimate (oL1)                 | Motor OL1 Level  | Shows the value of the motor overload detection accumulator. 100% is equal to the oL1 detection level.  | 10 V: 100%                 | 0.1%                     |
| U4-18 (07DA)    | Frequency Reference Source Selection          | Reference Source | Displays the source for the frequency reference as XY-nn.<br><b>X: indicates which reference is used:</b><br>1 = Reference 1 (b1-01)<br>2 = Reference 2 (b1-15)<br><b>Y-nn: indicates the reference source</b><br>0-01 = Digital operator<br>1-00 = Analog<br>1-01 = Analog (terminal A1)<br>1-02 = Analog (terminal A2)<br>1-03 = Analog (terminal A3)<br>2-02 to 17 = Multi-step speed (d1-02 to 17)<br>3-01 = MEMOBUS/Modbus communications<br>4-01 = Communication option card<br>5-01 = Pulse input<br>9-01 = Up/Down Command  | No signal output available | –                        |
| U4-19 (07DB)    | Frequency Reference from MEMOBUS/Modbus Comm. | MEMOBUS Freq Ref | Displays the frequency reference provided by MEMOBUS/Modbus (decimal).  | No signal output available | 0.01%                    |
| U4-20 (07DC)    | Option Frequency Reference                    | Option Freq Ref  | Displays the frequency reference input by an option card (decimal).   | No signal output available | –                        |
| U4-21 (07DD)    | Run Command Source Selection                  | Run Cmd Source   | Displays the source for the Run command as XY-nn.<br><b>X: Indicates which Run source is used:</b><br>1 = Reference 1 (b1-02)<br><b>Y: Input power supply data</b><br>0 = Digital operator<br>1 = External terminals<br>3 = MEMOBUS/Modbus communications<br>4 = Communication option card<br><b>nn: Run command limit status data</b><br>00: No limit status.<br>01: Run command was left on when stopped in the PRG mode<br>02: Run command was left on when switching from LOCAL to REMOTE operation<br>03: Waiting for soft charge bypass contactor after power up (Uv or Uv1 flashes after 10 s)<br>04: Waiting for “Run command prohibited” time period to end<br>05: Fast Stop (digital input, digital operator)<br>06: b1-17 (Run command given at power-up)<br>07: During baseblock while coast to stop with timer<br>08: Frequency reference is below minimal reference during baseblock<br>09: Waiting for Enter command<br>10: Run command was switched on while copying parameters<br>12: Clock is being set for RTC | No signal output available | –                        |
| U4-22 (07DE)    | MEMOBUS/Modbus Communications Reference       | MEMOBUS Ref Reg  | Displays the drive control data set by MEMOBUS/Modbus communications register no. 0001H as a four-digit hexadecimal number.   | No signal output available | –                        |
| U4-23 (07DF)    | Communication Option Card Reference           | Option Ref Reg   | Displays drive control data set by an option card as a four-digit hexadecimal number.   | No signal output available | –                        |

<1> The MEMOBUS/Modbus communications data is in 10 h units. If data in 1 h units are also required, refer to register number 0099H.

<2> The MEMOBUS/Modbus communications data is in 10 h units. If data in 1 h units are also required, refer to register number 009BH.

<3> Display is in the following units:

## B.16 U: Monitors

BV0006 to BV0018, 2V0006 to 2V0040, and 4V0002 to 4V0023: 0.01 A units.  
 2V0056 to 2V0069 and 4V0031 to 4V0038: 0.1 A units.

- <4> The values of U1-03, U2-05, and U4-13 are displayed on the digital operator in units of amperes. When those monitors are checked using MEMOBUS/Modbus communications, the monitor values in MEMOBUS/Modbus communications are displayed as: numeric value / 8192 × drive rated current (A) from the condition “192 (maximum value) = drive rated current (A)”
- <5> When reading the value of this monitor via MEMOBUS/Modbus a value of 8192 is equal to 100% of the drive rated output current.

### ◆ U5: PID Monitors

| No. (Addr. Hex) | Name                      | LCD Display    | Description  | Analog Output Level        | Unit         |
|-----------------|---------------------------|----------------|--|----------------------------|--------------|
| U5-01 (0057)    | PID Feedback 1            | PID Feedback 1 | Displays the PID feedback value.   | 10 V: 100%                 | 0.01%<br></> |
| U5-02 (0063)    | PID Input                 | PID Input      | Displays the amount of PID input (deviation between PID setpoint and feedback).  | 10 V: 100%                 | 0.01%        |
| U5-03 (0064)    | PID Output                | PID Output     | Displays PID control output.   | 10 V: 100%                 | 0.01%        |
| U5-04 (0065)    | PID Setpoint              | PID Setpoint   | Displays the PID setpoint.   | 10 V: 100%                 | 0.01%<br></> |
| U5-05 (07D2)    | PID Differential Feedback | PID Feedback 2 | Displays the 2nd PID feedback value if differential feedback is used (H3-□□ = 16).   | 10 V: 100%                 | 0.01%        |
| U5-06 (07D3)    | PID Adjusted Feedback     | PID Diff Fdbk  | Displays the difference of both feedback values if differential feedback is used (U5-01 - U5-05). If differential feedback is not used, then U5-01 and U5-06 will be the same. | 10 V: 100%                 | 0.01%        |
| U5-99 (1599)    | AUTO Setpoint             | Auto Setpoint  | Displays the PID Setpoint commanded by the source when the drive is in AUTO Mode.  | No signal output available | 0.01%<br></> |

- <1> Unit is determined by P1-02, System Units; scaling is determined by P1-03, Feedback Device Scaling; resolution is determined by b5-39, PID System Units Display Digits.

### ◆ U6: Control Monitors

| No. (Addr. Hex) | Name                         | LCD Display     | Description  | Analog Output Level                 | Unit |
|-----------------|------------------------------|-----------------|--|-------------------------------------|------|
| U6-01 (0051)    | Motor Secondary Current (Iq) | Mot SEC Current | Displays the value of the motor secondary current (Iq). Motor rated secondary current is 100%. | 10 V: Motor secondary rated current | 0.1% |

### ◆ U9: Operation Status Monitors

| No. (Addr. Hex) | Name                 | LCD Display       | Description   | Analog Output Level        | Unit          |
|-----------------|----------------------|-------------------|---|----------------------------|---------------|
| U9-01 (1901)    | Network PID Feedback | Net PI Feedback   | Displays the network PID feedback recognized by the iQpump MEMOBUS network.   | No signal output available | Dep. on P1-02 |
| U9-02 (1902)    | Network Activity     | iQ Net Activity   | Displays network traffic. A fluctuating number from 0 to 10000 denotes activity, while a relatively constant 0 denotes no activity. | No signal output available | </>           |
| U9-03 (1903)    | Time to Alternate    | Time to Alternate | Displays the time remaining before a drive requests the alternation mode set in P9-04.  | No signal output available | min           |
| U9-04 (1904)    | Running Queue Number | Running Queue No  | Displays the position in the iQPump MEMOBUS Multiplex running queue.  | No signal output available | –             |

- <1> Unit changes based on network status.  
 <->: Drive cannot communicate to other drives  
 <+>: Drive is a node on a network  
 <M>: Drive is the master on an iQpump network.



## B.17 Defaults by Drive Model

| No.          | Description  | Unit               | Default Settings |            |            |            |
|--------------|--|--------------------|------------------|------------|------------|------------|
|              |  |                    | BV0006           | BV0010     | BV0012     | BV0018     |
| -            | Model  | -                  |                  |            |            |            |
| <b>o2-04</b> | <b>Drive Model Selection</b>                                     | <b>Hex</b>         | <b>33</b>        | <b>34</b>  | <b>35</b>  | <b>37</b>  |
| <b>E2-11</b> | <b>Motor Rated Power</b>   | <b>kW</b>          | <b>1.1</b>       | <b>2.2</b> | <b>3.0</b> | <b>3.7</b> |
| b3-06        | Speed Search current 1   | -                  | 0.5              | 0.5        | 0.5        | 0.5        |
| b3-08        | Current Control Gain during Speed Search (Speed Estimation Type) | -                  | 0.5              | 0.5        | 0.5        | 0.5        |
| C6-02        | Carrier frequency  | -                  | 7                | 7          | 7          | 3          |
| E2-01        | Motor rated current  | A                  | 6.2              | 8.5        | 11.4       | 14.0       |
| E2-02        | Motor rated slip   | Hz                 | 2.6              | 2.9        | 2.7        | 2.73       |
| E2-03        | Motor no-load current  | A                  | 2.8              | 3          | 3.7        | 4.5        |
| E2-05        | Motor line-to-line resistance                                    | $\Omega$           | 1.997            | 1.601      | 1.034      | 0.771      |
| E2-06        | Motor leakage inductance   | %                  | 18.5             | 18.4       | 19         | 19.6       |
| E2-10        | Motor Iron Loss  | W                  | 53               | 77         | 91         | 112        |
| L2-02        | Momentary power loss ride-through time                           | s                  | 0.2              | 0.3        | 0.5        | 1.0        |
| L2-03        | Momentary power loss Baseblock time                              | s                  | 0.4              | 0.5        | 0.5        | 0.6        |
| L2-04        | Momentary power loss voltage recovery time                       | s                  | 0.3              | 0.3        | 0.3        | 0.3        |
| L2-05        | Uv detection voltage   | V dc               | 160              | 160        | 160        | 160        |
| L3-24        | Motor acceleration time  | s                  | 0.142            | 0.145      | 0.145      | 0.154      |
| L8-02        | Overheat alarm level   | $^{\circ}\text{C}$ | 105              | 100        | 95         | 100        |
| L8-09        | Ground fault selection   | -                  | 0                | 0          | 0          | 0          |
| L8-38        | Carrier frequency reduction selection                            | -                  | 1                | 1          | 1          | 1          |
| n1-03        | Hunting Prevention Time Constant                                 | ms                 | 10               | 10         | 10         | 10         |

## B.17 Defaults by Drive Model

**Table B.4 Three-Phase, 200 V Class Drives Default Settings by Drive Capacity**

| No.          | Description  | Unit       | Default Settings |            |            |            |            |
|--------------|--|------------|------------------|------------|------------|------------|------------|
|              |  |            | 2V0006           | 2V0010     | 2V0012     | 2V0020     | 2V0030     |
| –            | Model  | –          | 2V0006           | 2V0010     | 2V0012     | 2V0020     | 2V0030     |
| <b>o2-04</b> | <b>Drive Model Selection</b>                                     | <b>Hex</b> | <b>63</b>        | <b>65</b>  | <b>66</b>  | <b>68</b>  | <b>6A</b>  |
| <b>E2-11</b> | <b>Motor Rated Power</b>   | <b>kW</b>  | <b>1.1</b>       | <b>2.2</b> | <b>3.0</b> | <b>5.5</b> | <b>7.5</b> |
| b3-06        | Speed Search current I   | –          | 0.5              | 0.5        | 0.5        | 0.5        | 0.5        |
| b3-08        | Current Control Gain during Speed Search (Speed Estimation Type) | –          | 0.5              | 0.5        | 0.5        | 0.5        | 0.5        |
| C6-02        | Carrier frequency  | –          | 7                | 7          | 7          | 7          | 7          |
| E2-01        | Motor rated current  | A          | 4.9              | 8.5        | 11.4       | 19.6       | 26.6       |
| E2-02        | Motor rated slip   | Hz         | 2.6              | 2.9        | 2.7        | 1.5        | 1.3        |
| E2-03        | Motor no-load current  | A          | 2.3              | 3.0        | 3.7        | 5.1        | 8.0        |
| E2-05        | Motor line-to-line resistance                                    | Ω          | 3.577            | 1.601      | 1.034      | 0.399      | 0.288      |
| E2-06        | Motor leakage inductance   | %          | 18.5             | 18.4       | 19         | 18.2       | 15.5       |
| E2-10        | Motor Iron Loss  | W          | 38               | 77         | 91         | 172        | 262        |
| L2-02        | Momentary power loss ride-through time                           | s          | 0.2              | 0.3        | 0.5        | 1          | 1.0        |
| L2-03        | Momentary power loss Baseblock time                              | s          | 0.4              | 0.5        | 0.5        | 0.7        | 0.8        |
| L2-04        | Momentary power loss voltage recovery time                       | s          | 0.3              | 0.3        | 0.3        | 0.6        | 0.6        |
| L2-05        | Uv detection voltage   | V dc       | 190              | 190        | 190        | 190        | 190        |
| L3-24        | Motor acceleration time  | s          | 0.142            | 0.145      | 0.145      | 0.168      | 0.175      |
| L8-02        | Overheat alarm level   | °C         | 100              | 100        | 100        | 110        | 115        |
| L8-09        | Ground fault selection   | –          | 0                | 0          | 0          | 0          | 1          |
| L8-38        | Carrier frequency reduction selection                            | –          | 1                | 1          | 1          | 1          | 2          |
| n1-03        | Hunting Prevention Time Constant                                 | ms         | 10               | 10         | 10         | 10         | 10         |

| No.          | Description  | Unit       | Default Settings |             |             |
|--------------|--|------------|------------------|-------------|-------------|
|              |  |            | 2V0040           | 2V0056      | 2V0069      |
| -            | Model  | -          | 2V0040           | 2V0056      | 2V0069      |
| <b>o2-04</b> | <b>Drive Model Selection</b>                                     | <b>Hex</b> | <b>6B</b>        | <b>6D</b>   | <b>6E</b>   |
| <b>E2-11</b> | <b>Motor rated power</b>   | <b>kW</b>  | <b>11.0</b>      | <b>15.0</b> | <b>18.5</b> |
| b3-06        | Speed Search current I   | -          | 0.5              | 0.5         | 0.5         |
| b3-08        | Current Control Gain during Speed Search (Speed Estimation Type) | -          | 0.5              | 0.5         | 0.5         |
| C6-02        | Carrier frequency  | -          | 7                | 7           | 7           |
| E2-01        | Motor rated current  | A          | 39.7             | 53          | 65.8        |
| E2-02        | Motor rated slip   | Hz         | 1.7              | 1.6         | 1.67        |
| E2-03        | Motor no-load current  | A          | 11.2             | 15.2        | 15.7        |
| E2-05        | Motor line-to-line resistance                                    | Ω          | 0.230            | 0.138       | 0.101       |
| E2-06        | Motor leakage inductance   | %          | 19.5             | 17.2        | 15.7        |
| E2-10        | Motor Iron Loss  | W          | 245              | 272         | 505         |
| L2-02        | Momentary power loss ride-through time                           | s          | 1.0              | 2.0         | 2.0         |
| L2-03        | Momentary power loss Baseblock time                              | s          | 0.9              | 1.0         | 1.0         |
| L2-04        | Momentary power loss voltage recovery time                       | s          | 0.3              | 0.3         | 0.6         |
| L2-05        | Uv detection voltage   | V dc       | 190              | 190         | 190         |
| L3-24        | Motor acceleration time  | s          | 0.265            | 0.244       | 0.317       |
| L8-02        | Overheat alarm level   | °C         | 121              | 120         | 120         |
| L8-09        | Ground fault selection   | -          | 1                | 1           | 1           |
| L8-38        | Carrier frequency reduction selection                            | -          | 2                | 2           | 2           |
| n1-03        | Hunting Prevention Time Constant                                 | ms         | 10               | 10          | 10          |

## B.17 Defaults by Drive Model

**Table B.5 Three-Phase 400 V Class Drives Default Settings by Drive Capacity**

| No.          | Description  | Unit       | Default Settings |            |            |            |            |
|--------------|--|------------|------------------|------------|------------|------------|------------|
|              |  |            | 4V0002           | 4V0004     | 4V0005     | 4V0007     | 4V0009     |
| –            | Model  | –          | 92               | 93         | 94         | 95         | 96         |
| <b>o2-04</b> | <b>Drive Model Selection</b>                                     | <b>Hex</b> | <b>92</b>        | <b>93</b>  | <b>94</b>  | <b>95</b>  | <b>96</b>  |
| <b>E2-11</b> | <b>Motor rated power</b>   | <b>kW</b>  | <b>0.75</b>      | <b>1.5</b> | <b>2.2</b> | <b>3.0</b> | <b>3.7</b> |
| b3-06        | Speed Search current I   | –          | 0.5              | 0.5        | 0.5        | 0.5        | 0.5        |
| b3-08        | Current Control Gain during Speed Search (Speed Estimation Type) | –          | 0.5              | 0.5        | 0.5        | 0.5        | 0.5        |
| C6-02        | Carrier frequency  | –          | 7                | 7          | 7          | 7          | 7          |
| E2-01        | Motor rated current  | A          | 1.6              | 3.1        | 4.2        | 5.7        | 7          |
| E2-02        | Motor rated slip   | Hz         | 2.6              | 2.5        | 3          | 2.7        | 2.7        |
| E2-03        | Motor no-load current  | A          | 0.8              | 1.4        | 1.5        | 1.9        | 2.3        |
| E2-05        | Motor line-to-line resistance                                    | Ω          | 22.459           | 10.1       | 6.495      | 4.360      | 3.333      |
| E2-06        | Motor leakage inductance   | %          | 14.3             | 18.3       | 18.7       | 19         | 19.3       |
| E2-10        | Motor Iron Loss  | W          | 26               | 53         | 77         | 105        | 130        |
| L2-02        | Momentary power loss ride-through time                           | s          | 0.1              | 0.2        | 0.3        | 0.5        | 0.5        |
| L2-03        | Momentary power loss Baseblock time                              | s          | 0.3              | 0.4        | 0.5        | 0.5        | 0.6        |
| L2-04        | Momentary power loss voltage recovery time                       | s          | 0.3              | 0.3        | 0.3        | 0.3        | 0.3        |
| L2-05        | Uv detection voltage   | V dc       | 380              | 380        | 380        | 380        | 380        |
| L3-24        | Motor acceleration time  | s          | 0.142            | 0.166      | 0.145      | 0.145      | 0.154      |
| L8-02        | Overheat alarm level   | °C         | 110              | 110        | 90         | 100        | 100        |
| L8-09        | Ground fault selection   | –          | 0                | 0          | 0          | 0          | 0          |
| L8-38        | Carrier frequency reduction selection                            | –          | 1                | 1          | 1          | 1          | 1          |
| n1-03        | Hunting Prevention Time Constant                                 | ms         | 10               | 10         | 10         | 10         | 10         |

| No.          | Description  | Unit      | Setting Range |            |             |             |             |
|--------------|--|-----------|---------------|------------|-------------|-------------|-------------|
|              |  |           | 4V0011        | 4V0018     | 4V0023      | 4V0031      | 4V0038      |
| -            | <b>Model</b>   | -         | <b>97</b>     | <b>99</b>  | <b>9A</b>   | <b>9C</b>   | <b>9D</b>   |
| <b>o2-04</b> | <b>Drive Model Selection</b>                                     | -         | <b>97</b>     | <b>99</b>  | <b>9A</b>   | <b>9C</b>   | <b>9D</b>   |
| <b>E2-11</b> | <b>Motor Rated Power</b>   | <b>kW</b> | <b>5.5</b>    | <b>7.5</b> | <b>11.0</b> | <b>15.0</b> | <b>18.5</b> |
| b3-06        | Speed Search current 1   | -         | 0.5           | 0.5        | 0.5         | 0.5         | 0.5         |
| b3-08        | Current Control Gain during Speed Search (Speed Estimation Type) | -         | 0.5           | 0.5        | 0.5         | 0.5         | 0.5         |
| C6-02        | Carrier frequency  | -         | 7             | 7          | 7           | 7           | 7           |
| E2-01        | Motor rated current  | A         | 9.8           | 13.30      | 19.9        | 26.5        | 32.9        |
| E2-02        | Motor rated slip   | Hz        | 1.5           | 1.3        | 1.70        | 1.60        | 1.67        |
| E2-03        | Motor no-load current  | A         | 2.6           | 4.0        | 5.6         | 7.6         | 7.8         |
| E2-05        | Motor line-to-line resistance                                    | Ω         | 1.595         | 1.152      | 0.922       | 0.550       | 0.403       |
| E2-06        | Motor leakage inductance   | %         | 18.2          | 15.5       | 19.6        | 17.2        | 20.1        |
| E2-10        | Motor Iron Loss  | W         | 193           | 263        | 385         | 440         | 508         |
| L2-02        | Momentary power loss ride-through time                           | s         | 0.5           | 0.8        | 1           | 2           | 2           |
| L2-03        | Momentary power loss Baseblock time                              | s         | 0.7           | 0.8        | 0.9         | 1.0         | 1.0         |
| L2-04        | Momentary power loss voltage recovery time                       | s         | 0.3           | 0.3        | 0.3         | 0.6         | 0.6         |
| L2-05        | Uv detection voltage   | V dc      | 380           | 380        | 380         | 380         | 380         |
| L3-24        | Motor acceleration time  | s         | 0.154         | 0.175      | 0.265       | 0.244       | 0.317       |
| L8-02        | Overheat alarm level   | °C        | 100           | 110        | 110         | 110         | 110         |
| L8-09        | Ground fault selection   | -         | 0             | 1          | 1           | 1           | 1           |
| L8-38        | Carrier frequency reduction selection                            | -         | 1             | 2          | 2           | 2           | 2           |
| n1-03        | Hunting Prevention Time Constant                                 | ms        | 10            | 10         | 10          | 10          | 10          |

**This Page Intentionally Blank**

# Appendix: C

## **MEMOBUS/Modbus Communications**

---

|             |  |            |
|-------------|--|------------|
| <b>C.1</b>  | <b>SECTION SAFETY.....</b>                     | <b>384</b> |
| <b>C.2</b>  | <b>MEMOBUS/MODBUS CONFIGURATION.....</b>       | <b>385</b> |
| <b>C.3</b>  | <b>COMMUNICATION SPECIFICATIONS.....</b>       | <b>386</b> |
| <b>C.4</b>  | <b>CONNECTING TO A NETWORK.....</b>            | <b>387</b> |
| <b>C.5</b>  | <b>MEMOBUS/MODBUS SETUP PARAMETERS.....</b>    | <b>391</b> |
| <b>C.6</b>  | <b>DRIVE OPERATIONS BY MEMOBUS/MODBUS.....</b> | <b>395</b> |
| <b>C.7</b>  | <b>COMMUNICATIONS TIMING.....</b>              | <b>396</b> |
| <b>C.8</b>  | <b>MESSAGE FORMAT.....</b>                     | <b>397</b> |
| <b>C.9</b>  | <b>MESSAGE EXAMPLES.....</b>                   | <b>399</b> |
| <b>C.10</b> | <b>MEMOBUS/MODBUS DATA TABLE.....</b>          | <b>401</b> |
| <b>C.11</b> | <b>ENTER COMMAND.....</b>                      | <b>415</b> |
| <b>C.12</b> | <b>COMMUNICATION ERRORS.....</b>               | <b>416</b> |
| <b>C.13</b> | <b>SELF-DIAGNOSTICS.....</b>                   | <b>417</b> |

## C.1 Section Safety

### DANGER

#### Electrical Shock Hazard

**Do not connect or disconnect wiring while the power is on.**

Failure to comply will result in death or serious injury.

Before servicing, disconnect all power to the equipment. The internal capacitor remains charged even after the power supply is turned off. The charge indicator LED will extinguish when the DC bus voltage is below 50 Vdc. To prevent electric shock, wait at least one minute after all indicators are OFF and measure the DC bus voltage level to confirm safe level.

### WARNING

**Do not operate equipment with covers removed.**

Failure to comply could result in death or serious injury.

**Do not perform work on the drive while wearing loose clothing, jewelry or without eye protection.**

Failure to comply could result in death or serious injury.

Remove all metal objects such as watches and rings, secure loose clothing and wear eye protection before beginning work on the drive.

**Do not remove covers or touch circuit boards while the power is on.**

Failure to comply could result in death or serious injury.

**Do not allow unqualified personnel to use equipment.**

Failure to comply could result in death or serious injury.

Maintenance, inspection and replacement of parts must be performed only by authorized personnel familiar with installation, adjustment and maintenance of AC drives.

**Before wiring terminals, disconnect all power to the equipment.**

The internal capacitor remains charged even after the power supply is turned off. The charge indicator LED will extinguish when the DC bus voltage is below 50 Vdc. To prevent electric shock, wait at least one minute after all indicators are OFF and measure the DC bus voltage level to confirm safe level.

#### Fire Hazard

**Tighten all terminal screws to the specified tightening torque.**

Loose electrical connections could result in death or serious injury by fire due to overheating of electrical connections.

### CAUTION

#### Crush Hazard

**Do not carry the drive by the front cover.**

Failure to comply may result in minor or moderate injury from the main body of the drive falling.

### NOTICE

**Observe proper electrostatic discharge procedures (ESD) when handling the drive and circuit boards.**

Failure to comply may result in ESD damage to the drive circuitry.

**Check all the wiring to ensure that all connections are correct after installing the drive and connecting any other devices.**

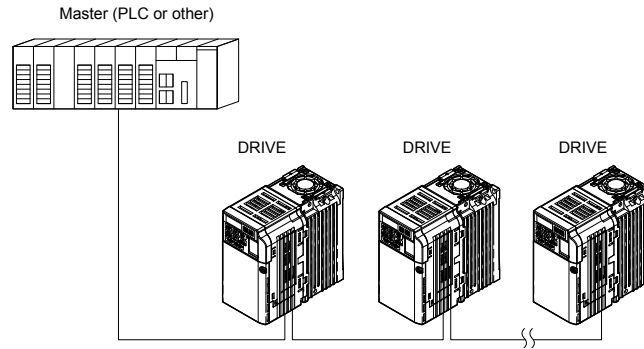
Failure to comply could result in damage to the drive.



## C.2 MEMOBUS/Modbus Configuration

Drives can be controlled from a PLC or other master device via serial communications using the MEMOBUS/Modbus protocol. MEMOBUS/Modbus communication can be configured using one master (PLC) and a maximum of 255 slaves. The drive has slave functionality only, meaning that serial communication is normally initiated from the master and responded to by the slaves.

The master performs serial communications with only one slave at a time. The address or node for each slave must be set beforehand so that the master can communicate with the slave at that address. A slave that receives a command from the master will perform the specified function and then send a response back to the master.



**Figure C.1 Connecting Multiple Drives to a PLC**

## C.3 Communication Specifications

MEMOBUS/Modbus specifications appear in the following table:

| Item                     | Specifications                            |  |
|--------------------------|---|--|
| Interface                | RS-422, RS-485                            |  |
| Communications Cycle     | Asynchronous (Start-stop synchronization) |  |
| Communication Parameters | Communication Speeds Available            | 1.2; 2.4; 4.8; 9.6; 19.2; 38.4; 57.6; 76.8; 115.2 kbps |
|                          | Data length                               | 8 bit (fixed)  |
|                          | Parity                                    | Select even, odd, or none                              |
|                          | Stop bit                                  | 1 bit (fixed)  |
| Protocol                 | MEMOBUS/Modbus (using RTU mode only)      |  |
| Max Number of Slaves     | 31 drives                                 |  |

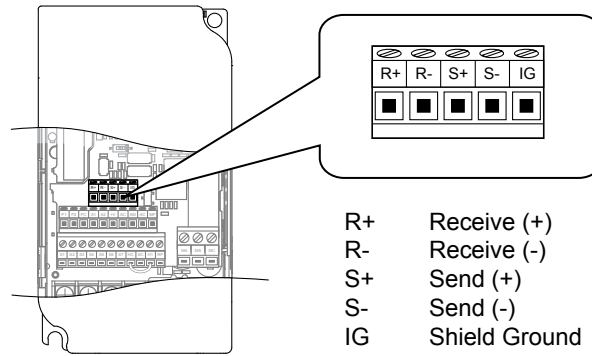
## C.4 Connecting to a Network

This section explains the connection of a drive to a MEMOBUS/Modbus network and the network termination.

### ◆ Network Cable Connection

Follow the instructions below to connect the drive to a MEMOBUS/Modbus network.

1. With the power shut off, connect the communications cable to the drive and the master. Use the terminals shown in the figure below for network cable connections.



**Figure C.2 Serial Communications Cable Connection Terminals**

**Note:** Separate the communications cables from the main circuit cables and other wiring and power cables. Use shielded cables for the communications cables, and properly shielded clamps to prevent problems with noise. When using RS-485 communications, connect S+ to R+, and S- to R- as shown in the diagram below.

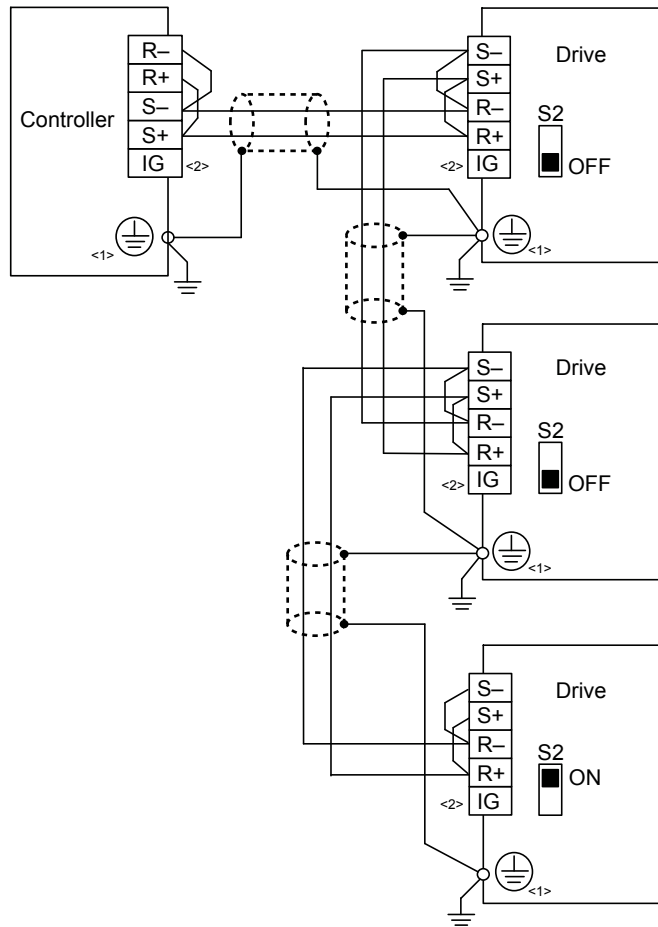
2. Check or set the terminating resistance at all slaves. Use the description in [Network Termination](#) for slaves that are 1000 series drives.
3. Switch the power on.
4. Set the parameters needed for serial communications (H5-01 through H5-12) using the LED operator.
5. Shut the power off and wait until the display on the LED operator goes out completely.
6. Turn the power back on.
7. The drive is now ready to begin communicating with the master.

### ◆ Wiring Diagram for Multiple Connections

Figure C.3 and Figure C.4 explain the wiring diagrams for multiple connections using MEMOBUS/Modbus communication.

#### ■ RS-485 Interface

**Note:** The isolated ground (IG) connection is optional but strongly recommended to improve network immunity to electrical interference.



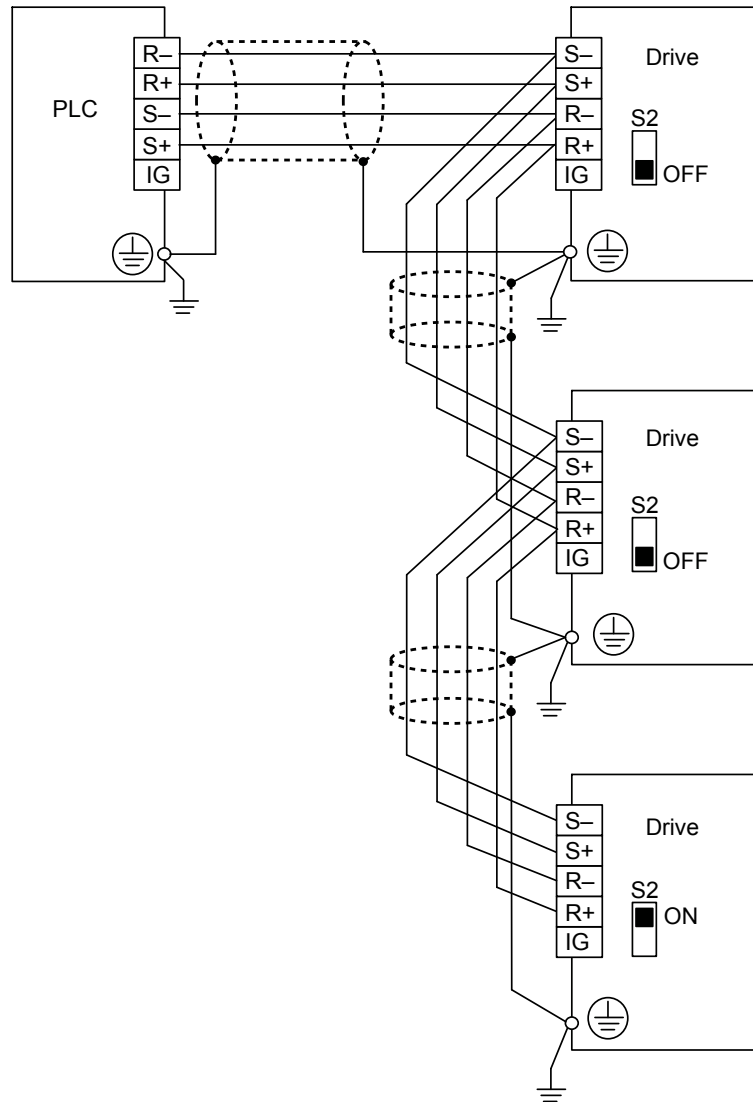
<1> The  $\oplus$  Ground symbol represents a direct electrical connection to the Earth. Connect the shield to ground at the controller side only if common mode noise issues are suspected.

<2> The IG terminal is the signal common point for the RS-485 transceiver chip power supply. Connect the isolated ground IG between all nodes to help prevent the coupling of external noise to the bus and to limit bus emissions if desired.

**Figure C.3 RS-485 Interface**

- Note:**
1. Set DIP switch S2 to the ON position on the drive located at the end of the network. Set DIP switch S2 to the OFF positions on all other slave devices.
  2. Set H5-07 to 1 when using the RS-485 interface.

## ■ RS-422 Interface



**Figure C.4 RS-422 Interface**

- Note:**
1. Set DIP switch S2 to the ON position on the drive located at the end of the network. Set DIP switch S2 to the OFF positions on all other slave devices.
  2. Set H5-07 to 1 when using the RS-422 interface in a multi-drop circuit.  
Set H5-07 to 0 when using the RS-422 interface in a point-to-point circuit.

### ◆ Network Termination

The two ends of the MEMOBUS/Modbus network line have to be terminated. The drive has a built in terminating resistance that can be enabled or disabled using DIP switch S2. If a drive is located at the end of a network line, enable the terminating resistance by setting DIP switch S2 to the ON position. Disable the terminating resistance on all slaves that are not located at the network line end. [Figure C.5](#) illustrates the setting of DIP switch S2.

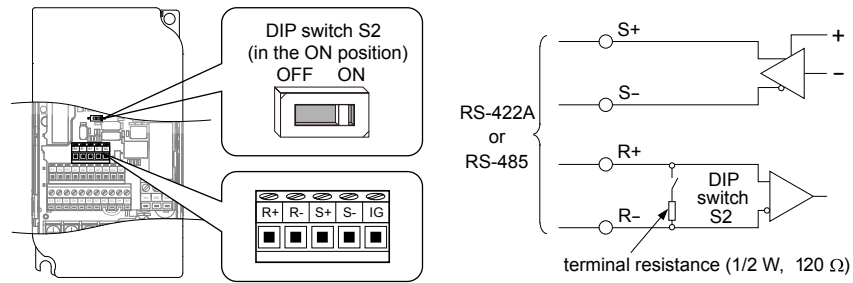


Figure C.5 Serial Communications Terminal and DIP Switch S2

## C.5 MEMOBUS/Modbus Setup Parameters

### ◆ MEMOBUS/Modbus Serial Communication

This section describes parameters necessary to set up MEMOBUS/Modbus communications.

#### ■ H5-01: Drive Slave Address

Sets the drive slave address used for MEMOBUS/Modbus communications.

**Note:** After changing this parameter, the power must be cycled to enable the new setting.

| No.   | Name                | Setting Range | Default |
|-------|---------------------|---------------|---------|
| H5-01 | Drive Slave Address | 0 to 20 H </> | 1F      |

<1> If the address is set to 0, no response will be provided during communications.

For serial communications to work, each individual slave drive must be assigned a unique slave address. Setting H5-01 to any value besides 0 assigns the drive its address in the network. Slave address don't need to be assigned in sequential order, but each address needs to be unique so that no two drives have the same address.

#### ■ H5-02: Communication Speed Selection

Sets the MEMOBUS/Modbus communications speed.

**Note:** After changing this parameter, the power must be cycled to enable the new setting.

| No.   | Name                          | Setting Range | Default |
|-------|-------------------------------|---------------|---------|
| H5-02 | Communication Speed Selection | 0 to 5        | 3       |

| H5-02 | Communication Speed | H5-02 | Communication Speed |
|-------|---------------------|-------|---------------------|
| 0     | 1200 bps            | 5     | 38400 bps           |
| 1     | 2400 bps            | 6     | 57600 bps           |
| 2     | 4800 bps            | 7     | 76800 bps           |
| 3     | 9600 bps            | 8     | 115200 bps          |
| 4     | 19200 bps           |       | –                   |

#### ■ H5-03: Communication Parity Selection

Sets the parity used for MEMOBUS/Modbus communications.

**Note:** After changing this parameter, the power must be cycled to enable the new setting.

| No.   | Name                           | Setting Range | Default |
|-------|--------------------------------|---------------|---------|
| H5-03 | Communication Parity Selection | 0 to 2        | 0       |

**Setting 0: No Parity**

**Setting 1: Even Parity**

**Setting 2: Odd Parity**

## C.5 MEMOBUS/Modbus Setup Parameters

### ■ H5-04: Stopping Method after Communication Error

Selects the stopping method after a communications error (CE) has occurred.

| No.   | Name                                      | Setting Range | Default |
|-------|---|---------------|---------|
| H5-04 | Stopping Method after Communication Error | 0 to 3        | 3       |

**Setting 0: Ramp to Stop Using Current Accel/Decel Time**

**Setting 1: Coast to Stop**

**Setting 2: Fast-stop Using C1-09**

**Setting 3: Alarm Only, Continue Operation**

### ■ H5-05: Communication Fault Detection Selection

Enables or disabled the communication error (CE) detection for MEMOBUS/Modbus communications.

| No.   | Name                                    | Setting Range | Default |
|-------|---|---------------|---------|
| H5-05 | Communication Fault Detection Selection | 0 or 1        | 1       |

**Setting 0: Disabled**

No error detection. The drive continues operation.

**Setting 1: Enabled**

If the drive does not receive data from the master for longer than the time set to H5-09, then a CE fault will be triggered and the drive will operate as determined by parameter H5-04.

### ■ H5-06: Drive Transmit Wait Time

Sets the time the drive waits after receiving data from a master until responding data.

| No.   | Name                     | Setting Range | Default |
|-------|--------------------------|---------------|---------|
| H5-06 | Drive Transmit Wait Time | 5 to 65 ms    | 5 ms    |

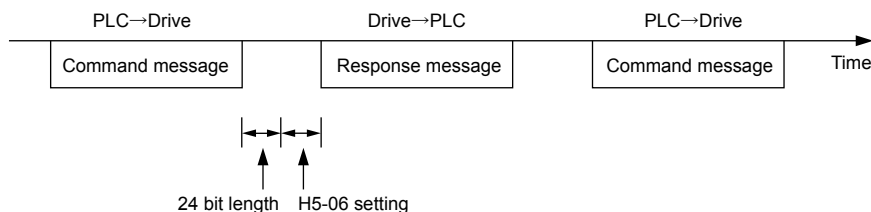


Figure C.6 Drive Transmit Wait Time Setting

### ■ H5-07: RTS Control Selection

Enables or disables RTS control.

| No.   | Name                  | Setting Range | Default |
|-------|-----------------------|---------------|---------|
| H5-07 | RTS Control Selection | 0 or 1        | 1       |

**Setting 0: Disabled - RTS is Always ON**

Use this setting when using RS-422 signals for communications (1:1).

**Setting 1: Enabled - RTS Switches while Sending**

Use this setting when using RS-485 signals for communications or when using the RS-422 signals for multi-drop communications.

### ■ H5-09: CE Detection Time

Sets the time the communications must be lost before the drive triggers a CE fault.

| No.   | Name              | Setting Range | Default |
|-------|-------------------|---------------|---------|
| H5-09 | CE Detection Time | 0.0 to 10.0 s | 2.0 s   |



**■ H5-10: Unit Selection for MEMOBUS/Modbus Register 0025H**

Sets the unit for the output voltage monitor value in MEMOBUS/Modbus register 0025H.

| No.   | Name   | Setting Range | Default |
|-------|--|---------------|---------|
| H5-10 | Unit Selection for MEMOBUS/Modbus Register 0025H | 0 or 1        | 0       |

**Setting 0: 0.1 V Units**

**Setting 1: 1 V Units**

## C.5 MEMOBUS/Modbus Setup Parameters

### ■ H5-11: Communications Enter Function Selection

Selects if an Enter command is needed to change parameter values via MEMOBUS/Modbus communications. *Refer to Enter Command on page 415.*

| No.   | Name                                    | Setting Range | Default |
|-------|---|---------------|---------|
| H5-11 | Communications Enter Function Selection | 0 or 1        | 0       |

#### Setting 0: Enter command necessary

Parameter changes become effective after an Enter command. An Enter command must only be sent after the last parameter change, not for each single parameter.

#### Setting 1: Enter command not necessary

Parameter value changes become effective immediately without the need to send an Enter command.

### ■ H5-12: Run Command Method Selection

Selects the type of sequence used when the Run command source is set to MEMOBUS/Modbus communications (b1-02/16 = 2).

| No.   | Name                         | Setting Range | Default |
|-------|------------------------------|---------------|---------|
| H5-12 | Run Command Method Selection | 0 or 1        | 0       |

#### Setting 0: FWD/Stop, REV/Stop

Bit 0 of MEMOBUS/Modbus register 0001H will start and stop the drive in the forward direction. Bit 1 will start and stop the drive in reverse.

#### Setting 1: Run/Stop, FWD/REV

Bit 0 of MEMOBUS/Modbus register 0001H will start and stop the drive. Bit 1 changes the direction.

## C.6 Drive Operations by MEMOBUS/Modbus

The drive operations that can be performed by MEMOBUS/Modbus communication depend on drive parameter settings. This section explains the functions that can be used and related parameter settings.

### ◆ Observing the Drive Operation

A PLC can perform the following actions with MEMOBUS/Modbus communications at any time regardless of parameter settings (except H5-□□).

- Observe drive status and drive control terminal status from a PLC.
- Read and write parameters.
- Set and reset faults.
- Set multi-function inputs. Inputs settings from the input terminals S□ and from MEMOBUS/Modbus communications are both linked by an OR operation.

### ◆ Controlling the Drive

To start and stop the drive or set the frequency reference using MEMOBUS/Modbus communications, an external reference must be selected and the parameters listed below must be adjusted accordingly.

**Table C.1 Setting Parameters for Drive Control from MEMOBUS/Modbus**

| Reference Source     | Parameter | Name                            | Required Setting |
|----------------------|-----------|---------------------------------|------------------|
| External Reference 1 | b1-01     | Frequency Reference Selection 1 | 2                |
|                      | b1-02     | Run Command Selection 1         | 2                |
| External Reference 2 | b1-15     | Frequency Reference Selection 2 | 2                |
|                      | b1-16     | Run Command Selection 2         | 2                |

*Refer to b1-01: Frequency Reference Selection 1 on page 115 and Refer to b1-02: Run Command Selection 1 on page 118 for details on external reference parameter selections. Refer to Setting 2: External Reference 1/2 Selection on page 164 for instructions on how to select external reference 1 and 2.*

## C.7 Communications Timing

To prevent overrun in the slave drive, the master should wait a certain time between sending messages to the same drive. In the same way, the slave drive must wait before sending response messages to prevent an overrun in the master. This section explains the message timing.

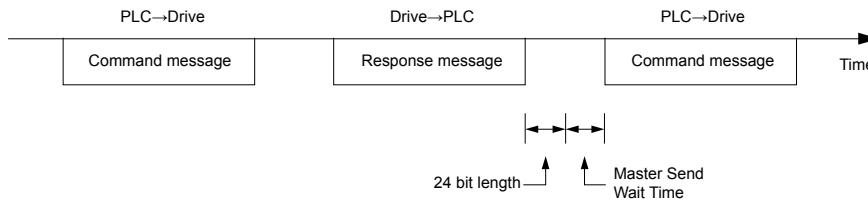
### ◆ Command Messages from Master to Drive

In order to prevent overrun and data loss, the master must wait between receiving a response and sending the same type of command as before to the same slave drive. The minimum wait time depends on the command as shown in the table below.

**Table C.2 Minimum Wait Time for Sending Messages**

| Command Type | Example   | Minimum Wait Time  |
|--------------|---|--|
| 1            | <ul style="list-style-type: none"> <li>Control command (Run, Stop)</li> <li>Set inputs/outputs</li> <li>Read monitors and parameter values</li> </ul> | 5 ms   |
| 2            | <ul style="list-style-type: none"> <li>Write parameters</li> </ul>  | H5-11 = 0: 50 ms<br>H5-11 = 1: 200 ms </>                        |
| 3            | <ul style="list-style-type: none"> <li>Save changes using an Enter command</li> </ul>   | 200 ms to 2 s, depending on the number of changed parameters </> |

<1> If the drive receives command type 1 data during the minimum wait time, it will perform the command and then respond. However, if it receives a command type 2 or 3 during that time, either a communication error will result or the command will be ignored.

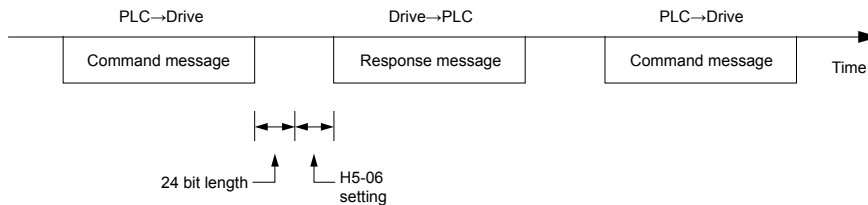


**Figure C.7 Minimum Wait Time for Sending Messages**

A timer should be set in the master to check how long it takes for the slave drive(s) to respond to the master. If no response is received within a certain amount of time, the master should try resending the message.

### ◆ Response Messages from Drive to Master

If the drive receives a command from the master, it will process the data received and wait for the time set in H5-06 until it responds. Increase H5-06 if the drive response causes overrun in the master.



**Figure C.8 Minimum Response Wait Time**

## C.8 Message Format

### ◆ Message Content

In MEMOBUS/Modbus communications, the master sends commands to the slave, and the slave responds. The message format is configured for both sending and receiving as shown below, and the length of data packets depends on the command (function) content.

|               |
|---------------|
| SLAVE ADDRESS |
| FUNCTION CODE |
| DATA          |
| ERROR CHECK   |

### ◆ Slave Address

The slave address in the message defines the note the message is sent to. Use addresses between 0 and 20H. If a message with slave address 0 is sent (broadcast), the command from the master will be received by all slaves. The slaves do not provide a response to a broadcast type message.

### ◆ Function Code

The three types of function codes are shown in the table below.

| Function Code | Function Name                              | Data Length (bytes) |         |                  |         |
|---------------|--|---------------------|---------|------------------|---------|
|               |  | Command Message     |         | Response Message |         |
|               |  | Minimum             | Maximum | Minimum          | Maximum |
| 03H           | Read MEMOBUS/Modbus registers              | 8                   | 8       | 7                | 37      |
| 08H           | Loopback test                              | 8                   | 8       | 8                | 8       |
| 10H           | Write to multiple MEMOBUS/Modbus registers | 11                  | 41      | 8                | 8       |

### ◆ Data

Configure consecutive data by combining the MEMOBUS/Modbus register address (test code in case of a loopback test) and the data the register contains. The data length changes depending on the command details.

A drive MEMOBUS/Modbus register always has a data length of two bytes. Therefore data written into drive registers must also always have a length of two bytes. Register data read out from the drive will always consist of two bytes.

### ◆ Error Check

The drive uses a CRC-16 (cyclic redundancy check, checksum method) for checking data validity. Use the procedure described below when calculating the CRC-16 checksum for command data or when verifying response data.

#### ■ Command Data

When the drive receives data, it calculates the CRC-16 checksum from the data and compares it to the CRC-16 value received within the message. Both must match before a command is processed.

An initial value of FFFFH (i.e., all 16 bits equal 1) must be used for CRC-16 calculations for the MEMOBUS/Modbus protocol.

Calculate the CRC-16 checksum using the following steps:

- The starting value is FFFFH.
- Perform an XOR operation of this value and the slave address.
- Right shift the result.
- When the overflow bit of the shift operation becomes 1, perform an XOR operation of the result from step 3 above and the fix value A001H.
- Repeat steps 3 and 4 until eight shift operations have been performed.
- After eight shift operations, perform an XOR operation with the result and the next data in the message (function code, register address, data). Continue with steps 3 to 5 until the last data has been processed.
- The result of the last shift or XOR operation is the checksum.

## C.8 Message Format

The example in [Table C.3](#) shows the CRC-16 calculation of the slave address 02H and the function code 03H, yielding the result D140H.

**Note:** This example does not show the calculation for a complete MEMOBUS/Modbus command. Normally data would follow in the calculation.

**Table C.3 CRC-16 Checksum Calculation Example**

| Description                                       | Calculation         | Overflow | Description       | Calculation                | Overflow |
|---|---------------------|----------|-------------------|----------------------------|----------|
| Initial Value (FFFFH)                             | 1111 1111 1111 1111 |          | Function Code 03H | 0000 0000 0000 0011        |          |
| Address 02H                                       | 0000 0000 0000 0010 |          | XOR w result      | 1000 0001 0011 1101        |          |
| XOR w initial value                               | 1111 1111 1111 1101 |          | Shift 1           | 0100 0000 1001 1110        | 1        |
| Shift 1   | 0111 1111 1111 1110 | 1        | XOR w A001H       | 1010 0000 0000 0001        |          |
| XOR w A001H                                       | 1010 0000 0000 0001 |          | XOR result        | 1110 0000 1001 1111        |          |
| XOR result  | 1101 1111 1111 1111 |          | Shift 2           | 0111 0000 0100 1111        | 1        |
| Shift 2   | 0110 1111 1111 1111 | 1        | XOR w A001H       | 1010 0000 0000 0001        |          |
| XOR w A001H                                       | 1010 0000 0000 0001 |          | XOR result        | 1101 0000 0100 1110        |          |
| XOR result  | 1100 1111 1111 1110 |          | Shift 3           | 0110 1000 0010 0111        | 0        |
| Shift 3   | 0110 0111 1111 1111 | 0        | Shift 4           | 0011 0100 0001 0011        | 0        |
| Shift 4   | 0011 0011 1111 1111 | 1        | XOR w A001H       | 1010 0000 0000 0001        |          |
| XOR w A001H                                       | 1010 0000 0000 0001 |          | XOR result        | 1001 0100 0001 0010        |          |
| XOR result  | 1001 0011 1111 1110 |          | Shift 5           | 0100 1010 0000 1001        | 0        |
| Shift 5   | 0100 1001 1111 1111 | 0        | Shift 6           | 0010 0101 0000 0100        | 1        |
| Shift 6   | 0010 0100 1111 1111 | 1        | XOR w A001H       | 1010 0000 0000 0001        |          |
| XOR w A001H                                       | 1010 0000 0000 0001 |          | XOR result        | 1000 0101 0000 0101        |          |
| XOR result  | 1000 0100 1111 1110 |          | Shift 7           | 0100 0010 1000 0010        | 1        |
| Shift 7   | 0100 0010 0111 1111 | 0        | XOR w A001H       | 1010 0000 0000 0001        |          |
| Shift 8   | 0010 0001 0011 1111 | 1        | XOR result        | 1110 0010 1000 0011        |          |
| XOR w A001H                                       | 1010 0000 0000 0001 |          | Shift 8           | 0111 0001 0100 0001        | 1        |
| XOR result  | 1000 0001 0011 1110 |          | XOR w A001H       | 1010 0000 0000 0001        |          |
| Perform operations with next data (function code) |                     |          | XOR result        | 1101 0001 0100 0000        |          |
|   |                     |          | CRC-16            | 1101 0001 0100 0000        |          |
|   |                     |          |                   | D 1 4 0<br>(Lower) (Upper) |          |
| Continue from here with next data.                |                     |          |                   |                            |          |

### ■ Response Data

To be sure that the data is valid, perform a CRC-16 calculation on the response message data as described above. Compare the result to the CRC-16 checksum that was received within the response message. Both should match.

## C.9 Message Examples

Below are some examples of command and response messages.

### ◆ Reading Drive MEMOBUS/Modbus Register Contents

Using the function code 03H (Read), a maximum of 16 MEMOBUS/Modbus registers can be read out at a time.

The following table shows message examples when reading status signals, error details, data link status, and frequency references from the slave 2 drive.

| Command Message |        |       | Response Message (normal) |                       |       | Response Message (fault) |       |     |
|-----------------|--------|-------|---------------------------|-----------------------|-------|--------------------------|-------|-----|
| Slave Address   | 02H    |       | Slave Address             | 02H                   |       | Slave Address            | 02H   |     |
| Function Code   | 03H    |       | Function Code             | 03H                   |       | Function Code            | 83H   |     |
| Starting No.    | Upper  | 00H   | Data Quantity             | 08H                   |       | Error Code               | 03H   |     |
|                 | Lower  | 20H   | 1st storage register      | Upper                 | 00H   | CRC-16                   | Upper | F1H |
| Data Quantity   | Upper  | 00H   |                           | Lower                 | 65H   |                          | Lower | 31H |
|                 | CRC-16 | Lower | 04H                       | Next storage register | Upper | 00H                      |       |     |
| Upper           |        | 45H   | Lower                     |                       | 00H   |                          |       |     |
| CRC-16          | Lower  | F0H   | Next storage register     | Upper                 | 00H   |                          |       |     |
|                 | Upper  |       |                           | Lower                 | 00H   |                          |       |     |
| CRC-16          | Lower  |       | Next storage register     | Upper                 | 01H   |                          |       |     |
|                 | Upper  |       |                           | Lower                 | F4H   |                          |       |     |
| CRC-16          | Lower  |       | CRC-16                    | Upper                 | AFH   |                          |       |     |
|                 | Upper  |       |                           | Lower                 | 82H   |                          |       |     |

### ◆ Loopback Test

Function code 08H performs a loopback test. This test returns a response message with exactly the same content as the command message and can be used to check the communications between the master and slave. User-defined test code and data values can be set.

The following table shows a message example when performing a loopback test with the slave 1 drive.

| Command Message |       |     | Response Message (normal) |       |     | Response Message (fault) |       |     |
|-----------------|-------|-----|---------------------------|-------|-----|--------------------------|-------|-----|
| Slave Address   | 01H   |     | Slave Address             | 01H   |     | Slave Address            | 01H   |     |
| Function Code   | 08H   |     | Function Code             | 08H   |     | Function Code            | 89H   |     |
| Test Code       | Upper | 00H | Test Code                 | Upper | 00H | Error Code               | 01H   |     |
|                 | Lower | 00H |                           | Lower | 00H | CRC-16                   | Upper | 86H |
| Data            | Upper | A5H | Data                      | Upper | A5H |                          | Lower | 50H |
|                 | Lower | 37H |                           | Lower | 37H |                          |       |     |
| CRC-16          | Upper | DAH | CRC-16                    | Upper | DAH |                          |       |     |
|                 | Lower | 8DH |                           | Lower | 8DH |                          |       |     |

### ◆ Writing to Multiple Registers

Function code 10h allows the user to write multiple drive MEMOBUS/Modbus registers with one message. This process works similar to reading registers, i.e., the address of the first register that is to be written and the data quantity must be set in the command message. The data to be written must be consecutive so that the register addresses are in order, starting from the specified address in the command message. The data order must be high byte, then lower byte.

The following table shows an example of a message where a forward operation has been set with a frequency reference of 60.00 Hz for the slave 1 drive.

If parameter values are changed using the Write command, depending on the setting of H5-11, an Enter command will be necessary to activate the data or save them. *Refer to H5-11: Communications Enter Function Selection on page 394* and *Refer to Enter Command on page 415* for detailed descriptions.

| Command Message |       |     | Response Message (normal) |       |     | Response Message (fault) |       |     |
|-----------------|-------|-----|---------------------------|-------|-----|--------------------------|-------|-----|
| Slave Address   |       | 01H | Slave Address             |       | 01H | Slave Address            |       | 01H |
| Function Code   |       | 10H | Function Code             |       | 10H | Function Code            |       | 90H |
| Starting No.    | Upper | 00H | Starting No.              | Upper | 00H | Error Code               |       | 02H |
|                 | Lower | 01H |                           | Lower | 01H |                          |       |     |
| Data Quantity   | Upper | 00H | Data Quantity             | Upper | 00H | CRC-16                   | Upper | CDH |
|                 | Lower | 02H |                           | Lower | 02H |                          | Lower | C1H |
| Number of Bytes |       | 04H | CRC-16                    | Upper | 10H |                          |       |     |
| Starting Data   | Upper | 00H |                           | Lower | 08H |                          |       |     |
|                 | Lower | 01H |                           |       |     |                          |       |     |
| Next Data       | Upper | 17H |                           |       |     |                          |       |     |
|                 | Lower | 70H |                           |       |     |                          |       |     |
| CRC-16          | Upper | 6DH |                           |       |     |                          |       |     |
|                 | Lower | 67H |                           |       |     |                          |       |     |

**Note:** For the number of bytes in the command message, take double the number of the data quantity.



## C.10 MEMOBUS/Modbus Data Table

Table below lists all MEMOBUS/Modbus data. There are three types of data: command data, monitor data, and broadcast data.

### ◆ Command Data

It is possible to both read and write command data.

**Note:** Bits that are not used should be set to 0. Refrain from writing to reserved registers.

| Register No. | Contents  |  |
|--------------|---|--|
| 0000H        | Reserved  |  |
| 0001H        | Operation Signals and Multi-function Inputs                             |  |
|              | bit 0   | H5-12 = 0: Forward Run Command (0 = Stop, 1 = Forward Run)<br>H5-12 = 1: Run Command (0 = Stop, 1 = Run)   |
|              | bit 1   | H5-12 = 0: Reverse Run Command (0 = Stop, 1 = Reverse Run)<br>H5-12 = 1: Forward/Reverse (0 = Forward, 1 = Reverse)  |
|              | bit 2   | External Fault (EF0)   |
|              | bit 3   | Fault Reset  |
|              | bit 4   | Multi-Function Input 1<br>Function is ComRef when H1-01 = 40 (Forward/Stop).<br><b>Note:</b> When the bit at ComRef is turned on, commands from MEMOBUS/Modbus communications take control of the frequency. When a communications option card is connected, that option card is given priority. |
|              | bit 5   | Multi-Function Input 2<br>Function is ComCtrl when H1-02 = 41 (Reverse/Stop).  |
|              | bit 6   | Multi-Function Input 3   |
|              | bit 7   | Multi-Function Input 4   |
|              | bit 8   | Multi-Function Input 5   |
|              | bit 9   | Multi-Function Input 6   |
|              | bit A   | Multi-Function Input 7   |
|              | bit B to F  | Reserved   |
| 0002H        | Frequency Reference   | Units are determined by parameter o1-03  |
| 0003H        | Output Voltage Gain   | Set in units of 1 (0.1%) with a setting range of 20 to 2000 (2.0% to 200.0%)<br><b>Note:</b> Initial value at power up: 1000 (100.0%)  |
| 0004H-0005H  | Reserved  |  |
| 0006H        | PID Target, 0.01% units, signed   |  |
| 0007H        | Analog Output Terminal AM Setting (10 V / 4000 H)                       |  |
| 0008H        | Reserved  |  |
| 0009H        | Settings for Multi-Function Digital Outputs                             |  |
|              | bit 0   | Contact Output (terminal MA/MB-MC)   |
|              | bit 1   | Photocoupler Output 1 (terminal P1-PC)   |
|              | bit 2   | Photocoupler Output 2 (terminal P2-PC)   |
| bit 3 to F   | Reserved  |  |
| 000AH        | Pulse Output Terminal MP Setting, 1 Hz units, Setting Range: 0 to 32000 |  |
| 000BH-000EH  | Reserved  |  |
| 000FH        | Control Selection Setting   |  |
|              | bit 0   | Reserved   |
|              | bit 1   | PID Target Input   |
|              | bit 2 to B  | Reserved   |
|              | bit C   | Enable Terminal S5 Input for Broadcast Data  |
|              | bit D   | Enable Terminal S6 Input for Broadcast Data  |
|              | bit E   | Enable Terminal S7 Input for Broadcast Data  |
| bit F        | Reserved  |  |

## C.10 MEMOBUS/Modbus Data Table

| Register No. | Contents   |                      |
|--------------|--|----------------------|
| 3004H        | Set Time – Hours/Minutes (HHmm)  |                      |
| 3005H        | Set Date – Year/Day of Week (YYdd)   |                      |
| 3006H        | Set Date – Month/Day (MMDD)  |                      |
| 3007H        | RTC Set Command/Statud<br>0 = Complete<br>1 = Set RTC data using registers 3004H to 3006H<br>8 = failed                        |                      |
| 302FH        | RTC Enter<br>0 = Overwrite RTC data using registers 3004H to 3006H. Only effective when 3030H bit 1 (RTC Enter Enable) is set. |                      |
| 3030H        | bit 1  | RTC Enter Enable     |
|              | bit 2  | RTC TIE Fault Enable |

## ◆ Monitor Data

Monitor data can be read only.

| Register No.   | Contents  |   |
|----------------|---|---|
| 0020H          | Drive Status 1  |   |
|                | bit 0   | During Run  |
|                | bit 1   | During Reverse  |
|                | bit 2   | Drive Ready   |
|                | bit 3   | Fault   |
|                | bit 4   | Data Setting Error  |
|                | bit 5   | Multi-Function Contact Output (terminal MA/MB-MC)   |
|                | bit 6   | Multi-Function Photocoupler Output 1 (terminal P1 - PC)                                       |
|                | bit 7   | Multi-Function Photocoupler Output 2 (terminal P2 - PC)                                       |
|                | bit 8 to bit D  | Reserved  |
|                | bit E   | When ComRef has been enabled  |
|                | bit F   | When ComCtrl has been enabled   |
| 0021H          | Fault Contents 1  |   |
|                | bit 0   | Overcurrent (oC), Ground fault (GF), IGBT Short Circuit or Ground Fault (SC)                  |
|                | bit 1   | Overvoltage (ov)  |
|                | bit 2   | Drive Overload (oL2)  |
|                | bit 3   | Overheat 1 (oH1), Drive Overheat Warning (oH2)  |
|                | bit 4   | Dynamic Braking Transistor Fault (rr), Braking Resistor Overheat (rH)                         |
|                | bit 5   | Reserved  |
|                | bit 6   | PID Feedback Loss (FbL/FbH)   |
|                | bit 7   | EF0 to 7: External Fault  |
|                | bit 8   | CPF□□: Hardware Fault (includes oFA□□)  |
|                | bit 9   | Motor Overload (oL1), Overtorque Detection 1/2 (oL3/oL4), Undertorque Detection 1/2 (UL3/UL4) |
|                | bit A   | Overspeed (oS)  |
|                | bit B   | Main Circuit Undervoltage (Uv)  |
|                | bit C   | Undervoltage (Uv1), Control Power Supply Undervoltage (Uv2), Soft Charge Circuit Fault (Uv3)  |
|                | bit D   | Output Phase Loss (LF), Input Phase Loss (PF)   |
|                | bit E   | MEMOBUS/Modbus Communication Error (CE), Option Communication Error (bUS)                     |
| bit F          | Operator Connection Fault (oPr)   |   |
| 0022H          | Data Link Status  |   |
|                | bit 0   | Writing data or switching motors  |
|                | bit 1   | Reserved  |
|                | bit 2   | Reserved  |
|                | bit 3   | Upper or lower limit error  |
|                | bit 4   | Data conformity error   |
|                | bit 5   | Writing to EEPROM   |
| bit 6 to bit F | Reserved  |   |
| 0023H          | Frequency Reference, <f>  |   |
| 0024H          | Output Frequency, <f>   |   |
| 0025H          | Output Voltage Reference, 0.1 V units (units are determined by parameter H5-10) |   |
| 0026H          | Output Current, <f>   |   |
| 0027H          | Output Power  |   |
| 0028H          | Torque Reference (OLV only)   |   |

## C.10 MEMOBUS/Modbus Data Table

| Register No. | Contents                                       |   |
|--------------|--|---|
| 0029H        | Fault Contents 2                               |   |
|              | bit 0  | IGBT Short Circuit or Ground Fault (SC) |
|              | bit 1  | Ground Fault (GF)                       |
|              | bit 2  | Input Phase Loss (PF)                   |
|              | bit 3  | Output Phase Loss (LF)                  |
|              | bit 4  | Braking Resistor Overheat (rH)          |
|              | bit 5  | Reserved                                |
|              | bit 6  | Motor Overheat 2 (PTC input) (oH4)      |
|              | bit 7 to bit F                                 | Reserved                                |
| 002AH        | Alarm Contents1                                |   |
|              | bit 0 to bit 1                                 | Reserved                                |
|              | bit 2  | Run Command Input Error (EF)            |
|              | bit 3  | Drive Baseblock (bb)                    |
|              | bit 4  | Overtorque Detection 1 (oL3)            |
|              | bit 5  | Heatsink Overheat (oH)                  |
|              | bit 6  | Overvoltage (ov)                        |
|              | bit 7  | Undervoltage (Uv)                       |
|              | bit 8  | Reserved                                |
|              | bit 9  | MEMOBUS/Modbus Communication Error (CE) |
|              | bit A  | Option Communication Error (bUS)        |
|              | bit B  | Undertorque Detection 1/2 (UL3/UL4)     |
|              | bit C  | Motor Overheat (oH3)                    |
|              | bit D  | Reserved                                |
| bit E        | Reserved                                       |   |
| bit F        | Serial Communication Transmission Error (CALL) |   |
| 002BH        | Input Terminal Status                          |   |
|              | bit 0  | Terminal S1 Closed                      |
|              | bit 1  | Terminal S2 Closed                      |
|              | bit 2  | Terminal S3 Closed                      |
|              | bit 3  | Terminal S4 Closed                      |
|              | bit 4  | Terminal S5 Closed                      |
|              | bit 5  | Terminal S6 Closed                      |
|              | bit 6  | Terminal S7 Closed                      |
|              | bit 7 to bit F                                 | Reserved                                |

| Register No.   | Contents   |   |
|----------------|--|---|
| 002CH          | Drive Status 2   |   |
|                | bit 0  | During Run  |
|                | bit 1  | Zero Speed  |
|                | bit 2  | Speed Agree   |
|                | bit 3  | User Speed Agree  |
|                | bit 4  | Frequency Detection 1                                   |
|                | bit 5  | Frequency Detection 2                                   |
|                | bit 6  | Drive Ready   |
|                | bit 7  | During Undervoltage                                     |
|                | bit 8  | During Baseblock  |
|                | bit 9  | Frequency Reference                                     |
|                | bit A  | Run Command   |
|                | bit B  | Over/Undertorque 1, 2                                   |
|                | bit C  | Frequency Reference Loss                                |
|                | bit D  | During Fault Restart                                    |
| bit E          | Fault  |   |
| bit F          | Communication Timeout  |   |
| 002DH          | Output Terminal Status   |   |
|                | bit 0  | Multi-Function Contact Output (terminal MA/MB-MC)       |
|                | bit 1  | Multi-Function Photocoupler Output 1 (terminal P1 - PC) |
|                | bit 2  | Multi-Function Photocoupler Output 2 (terminal P2 - PC) |
|                | bit 3 to bit F   | Reserved  |
| 002EH          | Reserved   |   |
| 002FH          | Frequency Reference Bias (from Up/Down 2 Function), 0.1% units                           |   |
| 0030H          | Reserved   |   |
| 0031H          | DC Bus Voltage, 1 Vdc units  |   |
| 0032H          | Torque Monitor, 1% units   |   |
| 0033H          | Reserved   |   |
| 0034H          | Product Code 1 [ASCII], Product Type   |   |
| 0035H          | Product Code 2 [ASCII], Region Code  |   |
| 0036H to 0037H | Reserved   |   |
| 0038H          | PID Feedback, 0.1% units, unsigned, 100% / max. output frequency                         |   |
| 0039H          | PID Input, 0.1% units, signed, 100% / max. output frequency                              |   |
| 003AH          | PID Output, 0.1% units, signed, 100% / max. output frequency                             |   |
| 003BH to 003CH | Reserved   |   |
| 003DH          | Communications Error Log <>  |   |
|                | bit 0  | CRC Error   |
|                | bit 1  | Data Length Error                                       |
|                | bit 2  | Reserved  |
|                | bit 3  | Parity Error  |
|                | bit 4  | Overflow Error  |
|                | bit 5  | Framing Error   |
|                | bit 6  | Timeout   |
| bit 7 to bit F | Reserved   |   |
| 003EH          | Output Frequency   | r/min <4>   |
| 003FH          |  | 0.01% units   |
| 0040H to 004AH | Used for various monitors U1-□□. Refer to U: Monitors on page 369 for parameter details. |   |

## C.10 MEMOBUS/Modbus Data Table

| Register No.   | Contents  |  |
|----------------|---|--|
| 004BH          | Drive status (U1-12)  |  |
|                | bit 0   | During Run   |
|                | bit 1   | During Zero Speed  |
|                | bit 2   | During Reverse Run   |
|                | bit 3   | During Fault Reset Signal Input  |
|                | bit 4   | During Speed Agree   |
|                | bit 5   | Drive Ready  |
|                | bit 6   | Alarm  |
|                | bit 7   | Fault  |
|                | bit 8   | During Operation Error (oPE□□)   |
|                | bit 9   | During Momentary Power Loss  |
|                | bit B to C  | Reserved   |
|                | bit D   | Hand Mode  |
|                | bit E   | ComRef status, NetRef status   |
| bit F          | ComCtrl status, NetCtrl status  |  |
| 004CH to 007EH | Used for various monitors U1-□□, U4-□□, U5-□□ and U6-□□. <i>Refer to U: Monitors on page 369</i> for parameter details.   |  |
| 007FH          | Alarm Code, <i>Refer to Alarm Register Contents on page 413</i> for alarm codes.  |  |
| 0080H to 0097H | Used for monitors U2-□□, U3-□□. <i>Refer to U: Monitors on page 369</i> for parameter details and <i>Refer to Fault Trace Contents on page 412</i> for register value descriptions. |  |
| 0098H, 0099H   | U4-01 (Cumulative Operation Time)<br>Example: When U4-01 (Cumulative Operation Time) is 12345 hours, then 0098H = 1234 and 0099H = 5.   |  |
| 009AH, 009BH   | U4-03 (Cooling Fan Operation Time)<br>Example: When U4-03 (Cooling Fan Operation Time) is 12345 hours, then 009AH = 1234 and 009BH = 5.   |  |
| 00ABH          | Drive Rated Current <2>   |  |
| 00ACH          | Motor Speed (Open Loop  | r/min units <4>  |
| 00ADH          | Vector only)  | 0.01% units  |
| 00AEH, 00AFH   | Reserved  |  |
| 00B0H          | Option Code   | The following lists the 3 and 4 letter ASCII codes stored for each serial communication option:<br>CANopen (Model: SI-S3/V): 5353H<br>CC-Link (Model: SI-C3/V): 5343H<br>DeviceNet (Model: SI-N3/V): 534EH<br>PROFIBUS-DP (Model: SI-P3/V): 5350H<br>MECHATROLINK-II (Model: SI-T3/V): 5354H<br>MECHATROLINK-III (Model: SI-ET3/V): 1004H<br>CompoNet (Model: SI-M3/V): 434EH<br>Other options use their own unique codes. Refer to the communication option instruction manual for the option code. |
| 00B1H to 00B4H | Reserved  |  |
| 00B5H          | Frequency Reference After   | r/min units <4>  |
| 00B6H          | Soft-starter  | 0.01% units  |
| 00B7H          | Frequency Reference   | r/min <4>  |
| 00B8H          |   | 0.01% units  |
| 00BFH          | oPE Error Number  |  |

| Register No. | Contents                        |   |
|--------------|---------------------------------|---|
| 00C0H        | Fault contents 3                |   |
|              | bit 0                           | Reserved                                  |
|              | bit 1                           | Undervoltage (Uv1)                        |
|              | bit 2                           | Control Power Supply Undervoltage (Uv2)   |
|              | bit 3                           | Soft Charge Circuit Fault (Uv3)           |
|              | bit 4                           | IGBT Short Circuit or Ground Fault (SC)   |
|              | bit 5                           | Ground Fault (GF)                         |
|              | bit 6                           | Overcurrent (oC)                          |
|              | bit 7                           | Overvoltage (ov)                          |
|              | bit 8                           | Heatsink Overheat (oH)                    |
|              | bit 9                           | Heatsink Overheat (oH1)                   |
|              | bit A                           | Motor Overload (oL1)                      |
|              | bit B                           | Drive Overload (oL2)                      |
|              | bit C                           | Overtorque Detection 1 (oL3)              |
|              | bit D                           | Overtorque Detection 2 (oL4)              |
|              | bit E                           | Dynamic Braking Transistor Fault (rr)     |
| bit F        | Braking Resistor Overheat (rH)  |   |
| 00C1H        | Fault contents 4                |   |
|              | bit 0                           | Pump Fault at input terminal S3 (EF3)     |
|              | bit 1                           | Pump Fault at input terminal S4 (EF4)     |
|              | bit 2                           | Pump Fault at input terminal S5 (EF5)     |
|              | bit 3                           | Pump Fault at input terminal S6 (EF6)     |
|              | bit 4                           | External Fault at input terminal S7 (EF7) |
|              | bit 5 to 6                      | Reserved                                  |
|              | bit 7                           | Overspeed (oS)                            |
|              | bit 8                           | Reserved                                  |
|              | bit 9                           | Reserved                                  |
|              | bit A                           | Input Phase Loss (PF)                     |
|              | bit B                           | Output Phase Loss (LF)                    |
|              | bit C                           | Motor Overheat Alarm (PTC input) (oH3)    |
|              | bit D                           | Digital Operator Connection Fault (oPr)   |
|              | bit E                           | EEPROM Write Error (Err)                  |
|              | bit F                           | Motor Overheat Fault (PTC input) (oH4)    |
| 00C2H        | Fault contents 5                |   |
|              | bit 0                           | MEMOBUS/Modbus Communication Error (CE)   |
|              | bit 1                           | Option Communication Error (bUS)          |
|              | bit 2 to 3                      | Reserved                                  |
|              | bit 4                           | Control Fault (CF)                        |
|              | bit 5                           | Reserved                                  |
|              | bit 6                           | Option External Fault (EF0)               |
|              | bit 7                           | Reserved                                  |
|              | bit 8                           | Undertorque Detection 1 (UL3)             |
|              | bit 9                           | Undertorque Detection 2 (UL4)             |
|              | bit A                           | High Slip Braking Overload (oL7)          |
|              | bit B to E                      | Reserved                                  |
| bit F        | Hardware fault (includes oFA□□) |   |

## C.10 MEMOBUS/Modbus Data Table

| Register No. | Contents         |  |
|--------------|------------------|--|
| 00C3H        | Fault contents 6 |  |
|              | bit 0 to 4       | Reserved                               |
|              | bit 5            | Output Current Imbalance (LF2)         |
|              | bit 6            | Pullout Detection (STo)                |
|              | bit 7            | Reserved                               |
|              | bit 8            | MECHATROLINK Watchdog Timer Error (E5) |
|              | bit 9            | Reserved                               |
|              | bit A            | Too many speed search restarts (SEr)   |
|              | bit B to F       | Reserved                               |
| 00C4H        | Fault contents 7 |  |
|              | bit 0            | Reserved                               |
|              | bit 1            | Pump Fault 1, input terminal S1 (EF1)  |
|              | bit 2            | Pump Fault 2, input terminal S2 (EF2)  |
|              | bit 3            | Mechanical Weakening Detection 1 (oL5) |
|              | bit 4            | Mechanical Weakening Detection 2 (UL5) |
|              | bit 5            | Current Offset Fault (CoF)             |
|              | bit 6            | Reserved                               |
|              | bit 7            | Reserved                               |
|              | bit 8            | Reserved                               |
| bit 9 to F   | Reserved         |  |
| 00C5H        | bit 9            | Underload Detection 6 (UL6)            |
| 00C6H        | bit 0            | Loss of Prime (LOP)                    |
|              | bit 3            | Low Feedback (LFB)                     |
|              | bit 4            | High Feedback (HFB)                    |
|              | bit 5            | Setpoint Not Met (NMS)                 |
|              | bit 6            | Pump Over Cycle (POC)                  |
|              | bit 8            | Net Master Lost (MSL)                  |
|              | bit A            | Anti-Jam Fault (AJF)                   |
|              | bit C            | Wire Break (FDBKL)                     |
|              | bit F            | Low Water Level (LWL)                  |
| 00C7H        | bit 0            | High Water Level (HWL)                 |
|              | bit 4            | Volute-TStat Flt (VLTS)                |
| 00C8H        | Alarm contents 2 |  |
|              | bit 0            | Undervoltage (Uv)                      |
|              | bit 1            | Overvoltage (ov)                       |
|              | bit 2            | Heatsink Overheat (oH)                 |
|              | bit 3            | Drive Overheat (oH2)                   |
|              | bit 4            | Overtorque 1 (oL3)                     |
|              | bit 5            | Overtorque 2 (oL4)                     |
|              | bit 6            | Run Commands Input Error (EF)          |
|              | bit 7            | Drive Baseblock (bb)                   |
|              | bit 8            | Pump Fault 3, input terminal S3 (EF3)  |
|              | bit 9            | Pump Fault 4, input terminal S4 (EF4)  |
|              | bit A            | Pump Fault 5, input terminal S5 (EF5)  |
|              | bit B            | Pump Fault 6, input terminal S6 (EF6)  |
|              | bit C            | Pump Fault 7, input terminal S7 (EF7)  |
|              | bit D, E         | Reserved                               |
| bit F        | Overspeed (oS)   |  |



| Register No. | Contents                               |  |
|--------------|--|--|
| 00C9H        | Alarm contents 3                       |  |
|              | bit 0                                  | Reserved   |
|              | bit 1                                  | Reserved   |
|              | bit 2                                  | Digital Operator Connection Fault (oPr)          |
|              | bit 3                                  | MEMOBUS/Modbus Communication Error (CE)          |
|              | bit 4                                  | Option Communication Error (bUS)                 |
|              | bit 5                                  | Serial Communication Transmission Error (CALL)   |
|              | bit 6                                  | Motor Overload (oL1)                             |
|              | bit 7                                  | Drive Overload (oL2)                             |
|              | bit 8                                  | Reserved   |
|              | bit 9                                  | Option Card External fault (EF0)                 |
|              | bit A                                  | Reserved   |
|              | bit B                                  | Reserved   |
|              | bit C                                  | Serial Communication Transmission Error (CALL)   |
|              | bit D                                  | Undertorque Detection 1 (UL3)                    |
|              | bit E                                  | Undertorque Detection 2 (UL4)                    |
| bit F        | MEMOBUS/Modbus Test Mode Fault (SE)    |  |
| 00CAH        | Alarm contents 4                       |  |
|              | bit 0                                  | Reserved   |
|              | bit 1                                  | Motor Overheat 1 (PTC Input) (oH3)               |
|              | bit 2 to 5                             | Reserved   |
|              | bit 6                                  | PID Feedback Loss (FbL)                          |
|              | bit 7                                  | PID Feedback Loss (FbH)                          |
|              | bit 9                                  | Drive Disabled (dnE)                             |
| bit A to F   | Reserved                               |  |
| 00CBH        | Alarm contents 5                       |  |
|              | bit 0                                  | MECHATROLINK Watchdog Timer Error (E5)           |
|              | bit 1                                  | Reserved   |
|              | bit 2                                  | MECHATROLINK Comm. Cycle Setting Error (CyC)     |
|              | bit 3                                  | High Current Alarm (HCA)                         |
|              | bit 4                                  | Cooling Fan Maintenance Time (LT-1)              |
|              | bit 5                                  | Soft Charge Bypass Relay Maintenance Time (LT-2) |
|              | bit 6                                  | Reserved   |
|              | bit 7                                  | SI-S/V EEPROM Error (EEP)                        |
|              | bit 8                                  | Pump Fault 1 (input terminal S1) (EF1)           |
|              | bit 9                                  | Pump Fault 2 (input terminal S2) (EF2)           |
|              | bit A                                  | Safe Disable Input (HbbF)                        |
|              | bit B                                  | Safe Disable Input (Hbb)                         |
|              | bit C                                  | Mechanical Weakening Detection 1 (oL5)           |
| bit D        | Mechanical Weakening Detection 2 (UL5) |  |
| bit E to F   | Reserved                               |  |
| 00CCH        | bit B                                  | Loss of Prime (LOP)                              |
|              | bit D                                  | Underload Detection 6 (UL6)                      |
|              | bit F                                  | AnalogFB Lost: Switched to Net                   |

## C.10 MEMOBUS/Modbus Data Table

| Register No. | Contents          |   |
|--------------|-------------------|---|
| 00CDH        | bit 0             | NETSCAN Wait for Master   |
|              | bit 1             | Pump Cycling Pump Over Cycle  |
|              | bit 2             | Low Feedback Low FB Sensed  |
|              | bit 3             | High Feedback High FB Sensed  |
|              | bit 5             | Freq. Ref < Pump Min P1-06  |
|              | bit 6             | Freq. Ref < Thrust (P4-12)  |
|              | bit 7             | Low City Pressure   |
|              | bit 8             | Anti-Jam Active   |
|              | bit B             | Feedback Loss Wire Break  |
|              | bit D             | R-DNE-Sx : Remote Drv Dis   |
|              | bit E             | Low Suction Pressure  |
| bit F        | Low Water in Tank |   |
| 00CEH        | bit 2             | Time Not Set (TIM)  |
|              | bit 3             | Battery Low (bAT)   |
|              | bit 4             | Time Deviation Error (TdE)  |
|              | bit 5             | Setpoint Not Met (NMS)  |
|              | bit 6             | Emergency Override FWD (EoF)  |
|              | bit 7             | Emergency Override REV (Eor)  |
|              | bit 8             | bit 8 - Feedback Loss Go To B5-13   |
| 00D0H        | CPF Contents 1    |   |
|              | bit 0 to 1        | Reserved  |
|              | bit 2             | A/D Conversion Error (CPF02)  |
|              | bit 3             | PWM Data Fault (CPF03)  |
|              | bit 4 to 5        | Reserved  |
|              | bit 6             | Drive specification mismatch during Terminal Board or Control Board replacement (CPF06) |
|              | bit 7             | Terminal Board Communications Fault (CPF07)   |
|              | bit 8             | EEPROM Serial Communications Fault (CPF08)  |
|              | bit 9 to A        | Reserved  |
|              | bit B             | RAM Fault (CPF11)   |
|              | bit C             | FLASH Memory Fault (CPF12)  |
|              | bit D             | Watchdog Circuit Exception (CPF13)  |
|              | bit E             | Control Circuit Fault (CPF14)   |
| bit F        | Reserved          |   |
| 00D1H        | CPF Contents 2    |   |
|              | bit 0             | Clock Fault (CPF16)   |
|              | bit 1             | Timing Fault (CPF17)  |
|              | bit 2             | Control Circuit Fault (CPF18)   |
|              | bit 3             | Control Circuit Fault (CPF19)   |
|              | bit 4             | Hardware fault at power up (CPF20)  |
|              | bit 5             | Hardware fault at communication start up (CPF21)  |
|              | bit 6             | A/D Conversion Fault (CPF22)  |
|              | bit 7             | PWM Feedback Fault (CPF23)  |
|              | bit 8             | Drive capacity signal fault (CPF24)   |
|              | bit 9             | Terminal board is not properly connected (CPF25)  |
| bit A to F   | Reserved          |   |

| Register No. | Contents                   |                                       |
|--------------|----------------------------|---------------------------------------|
| 00D8H        | Option Card Fault Contents |                                       |
|              | bit 0                      | Option Compatibility Error (oFA00)    |
|              | bit 1                      | Option not properly connected (oFA01) |
|              | bit 3                      | Option Self-diagnostics Error (oFA03) |
|              | bit 4                      | Option Flash Write Mode Error (oFA04) |
|              | bit 5 to F                 | Reserved                              |
| 00FBH        | Output Current <2>         |                                       |

- <1> Units are determined by parameter o1-03.
- <2> Display is in the following units: BA0001 to BA0018, 2A0001 to 2A0040, and 4A0001 to 4A0023: 0.01 A units.  
2A0056 to 2A0069, 4A0031 to 4A0038: 0.1 A units.
- <3> The communication error log is stored until the fault is reset.
- <4> Depending on the motor used the correct motor pole number must be set to parameter E2-04.

### ◆ Broadcast Messages

Data can be written from the master to all slave devices at the same time.

The slave address in a broadcast command message must be set to 00H. All slaves will receive the message, but will not respond.

| Register No. | Contents              |  |
|--------------|-----------------------|--|
| 0001H        | Digital Input Command |  |
|              | bit 0                 | Forward Run (0: Stop 1: Run)   |
|              | bit 1                 | Direction Command (0: Forward, 1: Reverse)                                   |
|              | bit 2, 3              | Reserved   |
|              | bit 4                 | External Fault   |
|              | bit 5                 | Fault Reset  |
|              | bit 6 to B            | Reserved   |
|              | bit C                 | Multi-Function Digital Input S5 (enabled when bit C of register 000FH is on) |
|              | bit D                 | Multi-Function Digital Input S6 (enabled when bit D of register 000FH is on) |
|              | bit E                 | Multi-Function Digital Input S7 (enabled when bit E of register 000FH is on) |
| bit F        | Reserved              |  |
| 0002H        | Frequency Reference   | 30000/100%   |

### ◆ Fault Trace Contents

The table below shows the fault codes that can be read out by MEMOBUS/Modbus commands from the U2-□□ monitor parameters.

**Note:** Uv1 and Uv2 faults are not saved to the fault history.

**Table C.4 Fault Trace / History Register Contents**

| Fault Code | Fault Name                                | Fault Code | Fault Name                                |
|------------|---|------------|---|
| 0002H      | Undervoltage (Uv1)                        | 0018H      | Overspeed (oS)                            |
| 0003H      | Control Power Supply Undervoltage (Uv2)   | 001BH      | Input Phase Loss (PF)                     |
| 0004H      | Soft Charge Circuit Fault (Uv3)           | 001CH      | Output Phase Loss (LF)                    |
| 0005H <I>  | IGBT Short Circuit (SC)                   | 001DH      | Motor Overheat (PTC input) (oH3)          |
| 0006H      | Ground Fault (GF)                         | 001EH      | Digital Operator Connection (oPr)         |
| 0007H      | Overcurrent (oC)                          | 001FH      | EEPROM Write Error (Err)                  |
| 0008H      | Overvoltage (ov)                          | 0020H      | Motor Overheat (PTC input) (oH4)          |
| 0009H      | Heatsink Overheat (oH)                    | 0021H      | MEMOBUS/Modbus Communication Error (CE)   |
| 0011H      | Pump Fault at Input Terminal S3 (EF3)     | 0022H      | Option Communication Error (bUS)          |
| 0012H      | Pump Fault at Input Terminal S4 (EF4)     | 0025H      | Control fault (CF)                        |
| 0013H      | Pump Fault at Input Terminal S5 (EF5)     | 0027H      | PROFIBUS-DP Option External Fault (EF0)   |
| 0014H      | Pump Fault at Input Terminal S6 (EF6)     | 0029H      | Undertorque Detection 1 (UL3)             |
| 0015H      | Pump Fault at Input Terminal S7 (EF7)     | 002AH      | Undertorque Detection 2 (UL4)             |
| 000AH      | Heatsink Overheat (oH1)                   | 002BH      | High Slip Braking Overload (oL7)          |
| 000BH      | Motor Overload (oL1)                      | 0030H      | Hardware Fault (including oFx)            |
| 000CH      | Drive Overload (oL2)                      | 0036H      | Output Current Imbalance (LF2)            |
| 000DH      | Overtorque Detection 1 (oL3)              | 0037H      | Pullout Detection (Sto)                   |
| 000EH      | Overtorque Detection 2 (oL4)              | 0039H      | MECHATROLINK Watchdog Timer Error (E5)    |
| 000FH      | Dynamic Braking Transistor (rr)           | 003BH      | Too many speed search restarts (SEr)      |
| 0010H      | Braking Resistor Overheat (rH)            | 0042H      | External Fault 1, input terminal S1 (EF1) |
| 0011H      | External Fault at input terminal S3 (EF3) | 0043H      | External Fault 2, input terminal S2 (EF2) |
| 0012H      | External Fault at input terminal S4 (EF4) | 0044H      | Mechanical Weakening Detection 1 (oL5)    |
| 0013H      | External Fault at input terminal S5 (EF5) | 0045H      | Mechanical Weakening Detection 2 (UL5)    |
| 0014H      | External Fault at input terminal S6 (EF6) | 0046H      | Current Offset Fault (CoF)                |
| 0015H      | External Fault at input terminal S7 (EF7) | 005AH      | Underload Detection 6 (UL6)               |
|            |   | 0061H      | Loss of Prime (LOP)                       |

| Fault Code | Fault Name  |
|------------|---|
| 0064H      | Low Feedback (LFB)  |
| 0065H      | High Feedback (HFB)   |
| 0066H      | Setpoint Not Met (NMS)  |
| 0067H      | Pump Over Cycle (POC)   |
| 0069H      | Net Master Lost (MSL)   |
| 006BH      | Anti-Jam Fault (AJF)  |
| 006DH      | Wire Break (FDBKL)  |
| 0070H      | Low Water Level (LWL)   |
| 0071H      | High Water Level (HWL)  |
| 0075H      | Volute-Thermostat Fault (VLTS)  |
| 0083H      | A/D Conversion Error (CPF02)  |
| 0084H      | PWM Data Fault (CPF03)  |
| 0087H      | Drive specification mismatch during Terminal Board or Control Board replacement (CPF06) |
| 0088H      | Terminal Board Communication Fault (CPF07)  |
| 0089H      | EEPROM Serial Communication Fault (CPF08)   |
| 008CH      | RAM fault (CPF11)   |

| Fault Code | Fault Name                                       |
|------------|--|
| 008DH      | Flash memory circuit exception (CPF12)           |
| 008EH      | Watchdog circuit exception (CPF13)               |
| 008FH      | Control Circuit Fault (CPF14)                    |
| 0091H      | Clock Fault (CPF16)                              |
| 0092H      | Timing Fault (CPF17)                             |
| 0093H      | Control Circuit Fault (CPF18)                    |
| 0094H      | Control Circuit Fault (CPF19)                    |
| 0095H      | Hardware fault at power up (CPF20)               |
| 0096H      | Hardware fault at communication start up (CPF21) |
| 0097H      | A/D Conversion Fault (CPF22)                     |
| 0098H      | PWM Feedback Fault (CPF23)                       |
| 0099H      | Drive capacity signal fault (CPF24)              |
| 0101H      | Option compatibility error (oFA00)               |
| 0102H      | Option not properly connected (oFA01)            |
| 0104H      | Option Self-diagnostics Error (oFA03)            |
| 0105H      | Option Flash Write Mode Error (oFA04)            |

<1> Available in drive software versions PRG: 1020 and later.

### ◆ Alarm Register Contents

The table below shows the alarm codes that can be read out from MEMOBUS/Modbus register 007FH.

Table C.5 Alarm Register 007FH Contents

| Alarm Code | Fault Name                                     |
|------------|--|
| 0001H      | Undervoltage (Uv)                              |
| 0002H      | Overvoltage (ov)                               |
| 0003H      | Heatsink Overheat (oH)                         |
| 0004H      | Drive Overheat (oH2)                           |
| 0005H      | Overtorque 1 (oL3)                             |
| 0006H      | Overtorque 2 (oL4)                             |
| 0007H      | Run commands input error (EF)                  |
| 0008H      | Drive Baseblock (bb)                           |
| 0009HP     | Pump Fault 3, input terminal S3 (EF3)          |
| 000AH      | Pump Fault 4, input terminal S4 (EF4)          |
| 000BH      | Pump Fault 5, input terminal S5 (EF5)          |
| 000CH      | Pump Fault 6, input terminal S6 (EF6)          |
| 000DH      | Pump Fault 7, input terminal S7 (EF7)          |
| 000FH      | Reserved                                       |
| 0010H      | Overspeed (oS)                                 |
| 0013H      | Digital operator connection fault (oPr)        |
| 0014H      | MEMOBUS/Modbus Communication Error (CE)        |
| 0015H      | Option Communication Error (bUS)               |
| 0016H      | Serial Communication Transmission Error (CALL) |
| 0017H      | Motor Overload (oL1)                           |
| 0018H      | Drive Overload (oL2)                           |
| 001AH      | Option Card External Fault (EF0)               |
| 001DH      | Serial Communication Transmission Error (CALL) |
| 001EH      | Undertorque Detection 1 (UL3)                  |
| 001FH      | Undertorque Detection 2 (UL4)                  |
| 0020H      | MEMOBUS/Modbus Test Mode Fault (SE)            |

| Alarm Code | Fault Name                                   |
|------------|--|
| 0022H      | Motor Overheat (oH3)                         |
| 002AH      | Drive Disabled (dnE)                         |
| 0031H      | MECHATROLINK Watchdog Timer Error (E5)       |
| 0032H      | Station Address Setting Error (AEr)          |
| 0033H      | MECHATROLINK Comm. Cycle Setting Error (CyC) |
| 0034H      | High Current Alarm (HCA)                     |
| 0039H      | External Fault (input terminal S1) (EF1)     |
| 003AH      | External Fault (input terminal S2) (EF2)     |
| 003BH      | Safe Disable Input (HbbF)                    |
| 003CH      | Safe Disable Input (Hbb)                     |
| 003DH      | Mechanical Weakening Detection 1 (oL5)       |
| 003EH      | Mechanical Weakening Detection 2 (UL5)       |
| 004CH      | Loss of Prime (LOP)                          |
| 004EH      | Underload Detection 6 (UL6)                  |
| 0050H      | AnalogFB Lost Switched to Net                |
| 0051H      | Waiting for Master (NETSCAN)                 |
| 0052H      | Pump Cycling Pump Over Cycle (PoC)           |
| 0053H      | Low Feedback Low FB Sensed                   |
| 0054H      | High Feedback High FB Sensed                 |
| 0056H      | Freq. Ref Pump Min (P1-06)                   |
| 0057H      | Freq. Ref Thrust (P4-12)                     |
| 0058H      | Low City Pressure                            |
| 005CH      | Feedback Loss Wire Break                     |
| 005EH      | R-DNE-Sx Remote Drv Dis                      |
| 005FH      | Low Suction Pressure                         |
| 0059H      | Anti Jam Active                              |



## C.10 MEMOBUS/Modbus Data Table

---

| Alarm Code | Fault Name                     | Alarm Code | Fault Name                     |
|------------|--------------------------------|------------|--------------------------------|
| 0060H      | Low Water In Tank              | 0066H      | Setpoint Not Met (NMS)         |
| 0063H      | Clock Not Set (TIM)            | 0067H      | Emergency Override FWD (EoF)   |
| 0064H      | HOA Battery Low (bAT)          | 0068H      | Emergency Override REV (Eor)   |
| 0065H      | HOA Time Deviation Error (TdE) | 0069H      | Feedback Loss Go To Freq b5-13 |

## C.11 Enter Command

When writing parameters to the drive from the PLC using MEMOBUS/Modbus communication it depends on the setting of parameter H5-11 if an Enter command must be used to enable these parameters or not. This sections explains Enter commands.

### ◆ Enter Command Types

The drive supports two types of Enter commands as shown in [Table C.6](#). An Enter command is enabled by writing 0 to register number 0900H or 0910H. These registers can be written to only. An error will occur if the user attempts to read from these registers.

**Table C.6 Enter Command Types**

| Register No. | Description   |
|--------------|---|
| 0900H        | Writes data into the EEPROM (non-volatile memory) of the drive and enables the data in RAM at the same time. Parameter changes remain even if the power supply is cycled. |
| 0910H        | Writes data in the RAM only. Parameter changes are lost when the drive is shut off.   |

- Note:**
1. Because the EEPROM can be written to a maximum of 100,000 times, refrain from writing to the EEPROM too often. The Enter command registers are write-only. Consequently, if these registers are read, then the register address will be invalid (Error code: 02H). An Enter command is not required if reference or broadcast data are sent to the drive.
  2. Parameter data cannot be written to EEPROM during undervoltage, even using 0900H.
  3. If undervoltage occurs when a making several parameter changes issued with a single ENTER command, the writing process may be aborted before all of the new changes have been written. Because all of the data has not yet been written, the EEPROM data error “CPF06” will be displayed the next time power to the drive is cycled. To prevent this problem, wait approximately 5 seconds after issuing the ENTER command before shutting off drive power.

### ■ H5-11 and the Enter Command

| H5-11 Settings                                  | H5-11 = 0  | H5-11 = 1   |
|---|--|---|
| Drive being replaced                            | G7, F7   | V7  |
| How parameter settings are enabled              | When the Enter command is received from the master.  | As soon as the value is changed.  |
| Upper/lower limit check                         | Upper/lower limit check takes the settings of related parameters into account.                                   | The upper/lower limit of the changed parameter is checked only.           |
| Default value of related parameters             | Not affected. The settings of related parameters remain unchanged. They must be changed manually if needed.      | The default settings of related parameters are changed automatically.     |
| Error handling when setting multiple parameters | Data is accepted even if one setting is invalid. The invalid setting will be discarded. No error message occurs. | Error occurs if only one setting is invalid. All data sent are discarded. |

## C.12 Communication Errors

### ◆ MEMOBUS/Modbus Error Codes

A list of MEMOBUS/Modbus errors appears below.

When an error occurs, remove whatever caused the error and restart communications.

| Error Code | Error Name  |
|------------|---|
|            | Cause   |
| 01H        | Function Code Error   |
|            | <ul style="list-style-type: none"> <li>Attempted to set a function code from a PLC other than 03H, 08H, and 10H.</li> </ul>   |
| 02H        | Register Number Error   |
|            | <ul style="list-style-type: none"> <li>A register number specified in the command message does not exist.</li> <li>Attempted to send a broadcast message using other register numbers than 0001H or 0002H.</li> </ul>   |
| 03H        | Bit Count Error   |
|            | <ul style="list-style-type: none"> <li>Read data or write data is greater than 16 bits. Invalid command message quantity.</li> <li>In a write message, the “Number of Data Items” contained within the message does not equal twice the amount of data words (i.e., the total of Data 1+ Data 2, etc.).</li> </ul>                          |
| 21H        | Data Setting Error  |
|            | <ul style="list-style-type: none"> <li>Control data or parameter write data is outside the allowable setting range.</li> <li>Attempted to write a contradictory parameter setting.</li> </ul>   |
| 22H        | Write Mode Error  |
|            | <ul style="list-style-type: none"> <li>Attempted to write while the drive was operating to a parameter that cannot be written to during run.</li> <li>During an EEPROM data error (CPF06), the master attempted to write to a parameter other than A1-00 to -05, E1-03, or o2-04.</li> <li>Attempted to write to read-only data.</li> </ul> |
| 23H        | DC Bus Undervoltage Write Error   |
|            | <ul style="list-style-type: none"> <li>Attempted to write from the master during an undervoltage fault (Uv1).</li> <li>Attempted to execute and Enter command during Uv1.</li> </ul>  |
| 24H        | Write Error During Parameter Process  |
|            | <ul style="list-style-type: none"> <li>Master attempted writing to the drive while the drive was processing parameter data.</li> </ul>  |

### ◆ Slave Not Responding

In the following situations, the slave drive will ignore the command message sent from the master, and not send a response message:

- When a communications error (overrun, framing, parity or CRC-16) is detected in the command message.
- When the slave address in the command message and the slave address in the drive do not match (remember to set the slave address for the drive using H5-01).
- When the gap between two blocks (8 bit) of a message exceeds 24 bits.
- When the command message data length is invalid.

**Note:** If the slave address specified in the command message is 00H, all slaves execute the write function, but do not return response messages to the master.



## C.13 Self-Diagnostics

The drive has a built-in self-diagnosing function of the serial communication interface circuits. To perform the self-diagnosis function, use the following procedure.

**DANGER! Electrical Shock Hazard.** Do not connect or disconnect wiring while the power is on. Failure to comply will result in death or serious injury. Before servicing, disconnect all power to the equipment. The internal capacitor remains charged even after the power supply is turned off. The charge indicator LED will extinguish when the DC bus voltage is below 50 Vdc. To prevent electric shock, wait at least one minute after all indicators are OFF and measure the DC bus voltage level to confirm safe level.

1. Turn on the power to the drive.
2. Note the present terminal S6 function selection setting (H1-06) and set it for the communications test mode (H1-06 = 67).
3. Turn off the power to the drive.
4. With the power off, wire the drive as shown in the following figure:

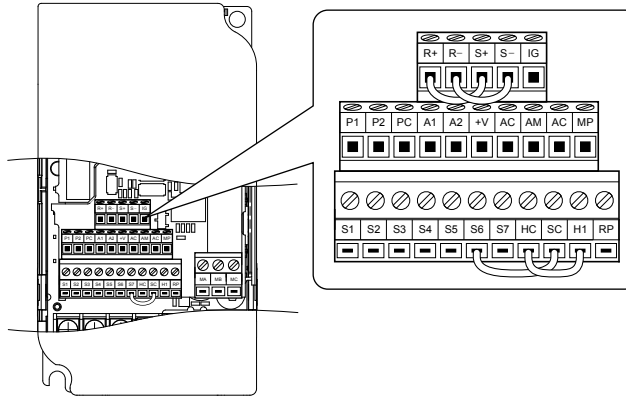


Figure C.9 Terminal Connections for Communication Self-Diagnostics

5. Check and note the setting of DIP switch S3. Set it to NPN if it is in the PNP position.
6. Turn the power to the drive back on.
7. During normal operation, the drive will display PASS. This indicates that the communications test mode is operating normally.  
When a fault occurs, the drive will display “CE” on the keypad display.
8. Turn off the power supply.
9. Remove the wire jumpers from terminal R+, R-, S+, S- and, S6-SC and set back DIP switch S3 to its original position. Set terminal S6 to its original function.
10. Return to normal operation.

**This Page Intentionally Blank**

# Appendix: D

## Standards Compliance

---

This chapter explains the guidelines and criteria for maintaining UL standards.

|            |                                  |            |
|------------|----------------------------------|------------|
| <b>D.1</b> | <b>SECTION SAFETY.....</b>       | <b>420</b> |
| <b>D.2</b> | <b>EUROPEAN STANDARDS.....</b>   | <b>422</b> |
| <b>D.3</b> | <b>UL AND CSA STANDARDS.....</b> | <b>427</b> |
| <b>D.1</b> | <b>UL STANDARDS.....</b>         | <b>435</b> |

## D.1 Section Safety

### DANGER

#### Electrical Shock Hazard

**Do not connect or disconnect wiring while the power is on.**

Failure to comply will result in death or serious injury.

### WARNING

#### Electrical Shock Hazard

**Do not operate equipment with covers removed.**

Failure to comply could result in death or serious injury.

The diagrams in this section may show drives without covers or safety shields to show details. Be sure to reinstall covers or shields before operating the drives and run the drives according to the instructions described in this manual.

**Always ground the motor-side grounding terminal.**

Improper equipment grounding could result in death or serious injury by contacting the motor case.

**Do not touch any terminals before the capacitors have fully discharged.**

Failure to comply could result in death or serious injury.

Before wiring terminals, disconnect all power to the equipment. The internal capacitor remains charged even after the power supply is turned off. The charge indicator LED will extinguish when the DC bus voltage is below 50 Vdc. To prevent electric shock, wait at least five minutes after all indicators are off and measure the DC bus voltage level to confirm safe level.

**Do not allow unqualified personnel to perform work on the drive.**

Failure to comply could result in death or serious injury.

Installation, maintenance, inspection, and servicing must be performed only by authorized personnel familiar with installation, adjustment and maintenance of AC drives.

**Do not perform work on the drive while wearing loose clothing, jewelry or without eye protection.**

Failure to comply could result in death or serious injury.

Remove all metal objects such as watches and rings, secure loose clothing, and wear eye protection before beginning work on the drive.

**Do not remove covers or touch circuit boards while the power is on.**

Failure to comply could result in death or serious injury.

#### Fire Hazard

**Tighten all terminal screws to the specified tightening torque.**

Loose electrical connections could result in death or serious injury by fire due to overheating of electrical connections.

**Do not use an improper voltage source.**

Failure to comply could result in death or serious injury by fire.

Verify that the rated voltage of the drive matches the voltage of the incoming power supply before applying power.

**Do not use improper combustible materials.**

Failure to comply could result in death or serious injury by fire.

Attach the drive to metal or other noncombustible material.

**Install adequate branch circuit protection according to applicable local codes and this manual.**

Failure to comply could result in fire and damage to the drive or injury to personnel. The device is suitable for use on a circuit capable of delivering not more than 31,000 RMS symmetrical amperes, 240 Vac maximum (200 V class) and 480 Vac maximum (400 V class) when protected by branch circuit protection devices specified in this manual.

**NOTICE**

**Observe proper electrostatic discharge procedures (ESD) when handling the drive and circuit boards.**

Failure to comply may result in ESD damage to the drive circuitry.

**Never connect or disconnect the motor from the drive while the drive is outputting voltage.**

Improper equipment sequencing could result in damage to the drive.

**Do not use unshielded cable for control wiring.**

Failure to comply may cause electrical interference resulting in poor system performance. Use shielded twisted-pair wires and ground the shield to the ground terminal of the drive.

**Do not allow unqualified personnel to use the product.**

Failure to comply could result in damage to the drive or braking circuit.

Carefully review instruction manual TOBPC72060000 when connecting a braking option to the drive.

**Do not modify the drive circuitry.**

Failure to comply could result in damage to the drive and will void warranty.

Yaskawa is not responsible for modification of the product made by the user. This product must not be modified.

**Check all the wiring to ensure that all connections are correct after installing the drive and connecting other devices.**

Failure to comply could result in damage to the drive.

## D.2 European Standards



Figure D.1 CE Mark

The CE mark indicates compliance with European safety and environmental regulations and is required for engaging in business and commerce in Europe.

European standards include the Machinery Directive for machine manufacturers, the Low Voltage Directive for electronics manufacturers and the EMC guidelines for controlling noise.

This drive displays the CE mark based on the EMC guidelines and the Low Voltage Directive.

- Devices used in combination with this drive must also be CE certified and display the CE mark. When using drives displaying the CE mark in combination with other devices, it is ultimately the responsibility of the user to ensure compliance with CE standards. After setting up the device, verify that conditions meet European standards.
- **Low Voltage Directive:** 73/23/EEC, 93/68/EEC

### ◆ CE Low Voltage Directive Compliance

This drive has been tested according to European standard IEC/EN 61800-5-1, and it fully complies with the Low Voltage Directive.

To comply with the Low Voltage Directive, be sure to meet the following conditions when combining this drive with other devices:

#### ■ Area of Use

Do not use drives in areas with pollution higher than severity 2 and overvoltage category 3 in accordance with IEC/EN 664.

#### ■ Factory Recommended Branch Circuit Protection

Yaskawa recommends installing one of the following types of branch circuit protection to maintain compliance with UL508C. Semiconductor protective type fuses are preferred. Alternate branch circuit protection devices are also listed in [Table D.1](#).

**NOTICE:** If a fuse is blown or a Ground Fault Circuit Interrupter (GFCI) is tripped, check the wiring and the selection of peripheral devices to identify the cause. Contact Yaskawa before restarting the drive or the peripheral devices if the cause cannot be identified.

Table D.1 Factory Recommended Drive Branch Circuit Protection

| Drive Model                     | Fuse Type              |                        |
|---------------------------------|------------------------|------------------------|
|                                 | Manufacturer: Bussmann |                        |
|                                 | Model                  | Fuse Ampere Rating (A) |
| <b>Single-Phase 200 V Class</b> |                        |                        |
| BA0001                          | FWH-25A14F             | 25                     |
| BA0002                          | FWH-25A14F             | 25                     |
| BA0003                          | FWH-60B                | 60                     |
| BA0006                          | FWH-80B                | 80                     |
| BA0010                          | FWH-100B               | 100                    |
| <b>Three-Phase 200 V Class</b>  |                        |                        |
| 2A0001                          | FWH-25A14F             | 25                     |
| 2A0002                          | FWH-25A14F             | 25                     |
| 2A0004                          | FWH-25A14F             | 25                     |
| 2A0006                          | FWH-25A14F             | 25                     |
| 2A0010                          | FWH-70B                | 70                     |
| 2A0012                          | FWH-70B                | 70                     |
| 2A0020                          | FWH-90B                | 90                     |
| <b>Three-Phase 400 V Class</b>  |                        |                        |
| 4A0001                          | FWH-40B                | 40                     |
| 4A0002                          | FWH-40B                | 40                     |

| Drive Model | Fuse Type              |                        |
|-------------|------------------------|------------------------|
|             | Manufacturer: Bussmann |                        |
|             | Model                  | Fuse Ampere Rating (A) |
| 4A0004      | FWH-50B                | 50                     |
| 4A0005      | FWH-70B                | 70                     |
| 4A0007      | FWH-70B                | 70                     |
| 4A0009      | FWH-90B                | 90                     |
| 4A0011      | FWH-90B                | 90                     |

■ **Grounding**

The drive is designed to be used in T-N (grounded neutral point) networks. If installing the drive in other types of grounded systems, contact your dealer or Yaskawa for instructions.

■ **CE Standards Compliance for DC Power Supply Input**

Install the fuses in the following tables to meet CE standards.

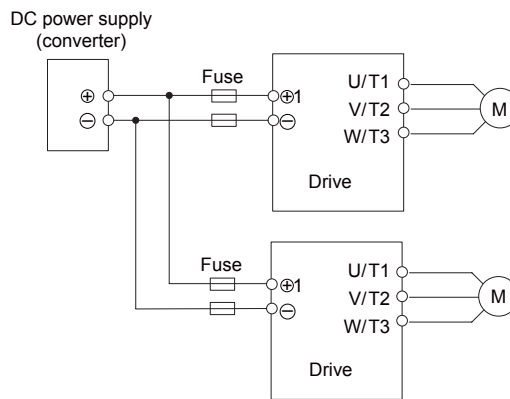


Figure D.2 Example of DC Power Supply Input (Two Drives Connected in Series)

- Note:**
1. When connecting multiple drives together, make sure that each drive has its own fuse. Replace all fuses when one fuse blows.
  2. Refer to on page 40 for an AC power supply.
  3. The recommended fuses and fuse holders are made by Fuji Electric.

Table D.2 Single-Phase 200 V Class Fuses and Fuse Holders

| Drive Model | DC Power Supply Input       |  |      |             |      |
|-------------|-----------------------------|--|------|-------------|------|
|             | Fuse                        |  |      | Fuse Holder |      |
|             | Manufacturer: Fuji Electric |  |      |             |      |
|             | Type                        | Rated Short Circuit Braking Current (kA) | Qty. | Type        | Qty. |
| BA0001      | CR6L-20/UL                  | 100                                      | 2    | CMS-4       | 2    |
| BA0002      | CR6L-30/UL                  |  |      | CMS-4       |      |
| BA0003      | CR6L-50/UL                  |  |      | CMS-4       |      |
| BA0006      | CR6L-75/UL                  |  |      | CMS-5       |      |
| BA0010      | CR6L-100/UL                 |  |      | CMS-5       |      |

## D.2 European Standards

Table D.3 Three-Phase 200 V Class Fuses and Fuse Holders

| Drive Model | DC Power Supply Input       |  |      |             |      |
|-------------|-----------------------------|--|------|-------------|------|
|             | Fuse                        |  |      | Fuse Holder |      |
|             | Manufacturer: Fuji Electric |  |      |             |      |
|             | Type                        | Rated Short Circuit Braking Current (kA) | Qty. | Type        | Qty. |
| 2A0001      | CR6L-20/UL                  | 100                                      | 2    | CMS-4       | 2    |
| 2A0002      | CR6L-20/UL                  |  |      | CMS-4       |      |
| 2A0004      | CR6L-20/UL                  |  |      | CMS-4       |      |
| 2A0006      | CR6L-30/UL                  |  |      | CMS-4       |      |
| 2A0010      | CR6L-50/UL                  |  |      | CMS-4       |      |
| 2A0012      | CR6L-50/UL                  |  |      | CMS-4       |      |
| 2A0020      | CR6L-75/UL                  |  |      | CMS-5       |      |

Table D.4 Three-Phase 400 V Class Fuses and Fuse Holders

| Drive Model | DC Power Supply Input       |  |      |             |      |
|-------------|-----------------------------|--|------|-------------|------|
|             | Fuse                        |  |      | Fuse Holder |      |
|             | Manufacturer: Fuji Electric |  |      |             |      |
|             | Type                        | Rated Short Circuit Braking Current (kA) | Qty. | Type        | Qty. |
| 4A0001      | CR6L-20/UL                  | 100                                      | 2    | CMS-4       | 2    |
| 4A0002      | CR6L-20/UL                  |  |      | CMS-4       |      |
| 4A0004      | CR6L-50/UL                  |  |      | CMS-4       |      |
| 4A0005      | CR6L-50/UL                  |  |      | CMS-4       |      |
| 4A0007      | CR6L-50/UL                  |  |      | CMS-4       |      |
| 4A0009      | CR6L-50/UL                  |  |      | CMS-4       |      |
| 4A0011      | CR6L-50/UL                  |  |      | CMS-4       |      |

### ■ Guarding Against Harmful Materials

When installing IP20/Open-Chassis enclosure drives, use an enclosure that prevents foreign material from entering the drive from above or below.

### ◆ EMC Guidelines Compliance

This drive is tested according to European standards EN 61800-3:2004/A1:2012 and it complies with the EMC guidelines.

### ■ EMC Filter Installation

The following conditions must be met to ensure continued compliance with guidelines. [Refer to EMC Filters on page 425](#) for EMC filter selection.

#### Installation Method

Verify the following installation conditions to ensure that other devices and machinery used in combination with this drive also comply with EMC guidelines.

1. Install an EMC noise filter to the input side specified by Yaskawa for compliance with European standards.
2. Place the drive and EMC noise filter in the same enclosure.
3. Use braided shield cable for the drive and motor wiring or run the wiring through a metal conduit.
4. Keep wiring as short as possible. Ground the shield on both the drive side and the motor side.
5. Ground the largest possible surface area of the shield to the metal conduit when using braided shield cable. Yaskawa recommends using a cable clamp.



Three-Phase 200 V / 400 V Class

Single-Phase 200 V Class

■ EMC Filters

The drive should be installed with the EMC filters listed below in order to comply with the EN 61800-3:2004/A1:2012, category C1 requirements.

Table D.5 EN 61800-3:2004/A1:2012 Category C1 Filters

| Filter Data (Manufacturer: Schaffner) |                   |             |                             |                                  |                        |                       |    |
|---------------------------------------|-------------------|-------------|-----------------------------|----------------------------------|------------------------|-----------------------|----|
| Type                                  | Rated Current (A) | Weight (lb) | Dimensions [W x L x H] (in) | Mounting Dimensions [Y x X] (in) | Drive Mounting Screw A | Filter Mounting Screw |    |
| <b>200 V Class Single-Phase</b>       |                   |             |                             |                                  |                        |                       |    |
| BA0001                                | FS23638-10-07     | 10          | 0.97                        | 2.8 x 6.7 x 1.8                  | 2.0 x 6.1              | M4                    | M5 |
| BA0002                                | FS23638-10-07     | 10          | 0.97                        | 2.8 x 6.7 x 1.8                  | 2.0 x 6.1              | M4                    | M5 |
| BA0003                                | FS23638-10-07     | 10          | 0.97                        | 2.8 x 6.7 x 1.8                  | 2.0 x 6.1              | M4                    | M5 |
| BA0006                                | FS23638-20-07     | 20          | 1.65                        | 4.4 x 6.7 x 2.0                  | 3.6 x 6.1              | M4                    | M5 |
| BA0010                                | FS23638-20-07     | 20          | 1.65                        | 4.4 x 6.7 x 2.0                  | 3.6 x 6.1              | M4                    | M5 |
| <b>200 V Three-Phase</b>              |                   |             |                             |                                  |                        |                       |    |
| 2A0001                                |                   | 7.3         | 0.88                        | 2.8 x 6.7 x 1.6                  | 2.0 x 6.1              | M4                    | M5 |
| 2A0002                                |                   | 7.3         | 0.88                        | 2.8 x 6.7 x 1.6                  | 2.0 x 6.1              | M4                    | M5 |
| 2A0004                                |                   | 7.3         | 0.88                        | 2.8 x 6.7 x 1.6                  | 2.0 x 6.1              | M4                    | M5 |
| 2A0006                                |                   | 7.3         | 0.88                        | 2.8 x 6.7 x 1.6                  | 2.0 x 6.1              | M4                    | M5 |
| 2A0010                                | FS23637-14-07     | 14          | 1.28                        | 4.4 x 6.7 x 1.8                  | 3.6 x 6.1              | M4                    | M5 |
| 2A0012                                | FS23637-14-07     | 14          | 1.28                        | 4.4 x 6.7 x 1.8                  | 3.6 x 6.1              | M4                    | M5 |
| 2A0020                                | FS23637-24-07     | 24          | 1.98                        | 5.7 x 6.9 x 2.0                  | 4.7 x 6.1              | M4                    | M5 |
| <b>400 V Class Three-Phase</b>        |                   |             |                             |                                  |                        |                       |    |
| 4A0001                                | FS23639-5-07      | 5           | 1.10                        | 4.4 x 6.7 x 1.8                  | 3.6 x 6.1              | M4                    | M5 |
| 4A0002                                | FS23639-5-07      | 5           | 1.10                        | 4.4 x 6.7 x 1.8                  | 3.6 x 6.1              | M4                    | M5 |
| 4A0004                                | FS23639-5-07      | 5           | 1.10                        | 4.4 x 6.7 x 1.8                  | 3.6 x 6.1              | M4                    | M5 |
| 4A0005                                | FS23639-10-07     | 10          | 1.54                        | 4.4 x 6.7 x 1.8                  | 3.6 x 6.1              | M4                    | M5 |
| 4A0007                                | FS23639-10-07     | 10          | 1.54                        | 4.4 x 6.7 x 1.8                  | 3.6 x 6.1              | M4                    | M5 |
| 4A0009                                | FS23639-10-07     | 10          | 1.54                        | 4.4 x 6.7 x 1.8                  | 3.6 x 6.1              | M4                    | M5 |
| 4A0011                                | FS23639-15-07     | 15          | 1.98                        | 5.7 x 6.9 x 2.0                  | 4.7 x 6.3              | M4                    | M5 |

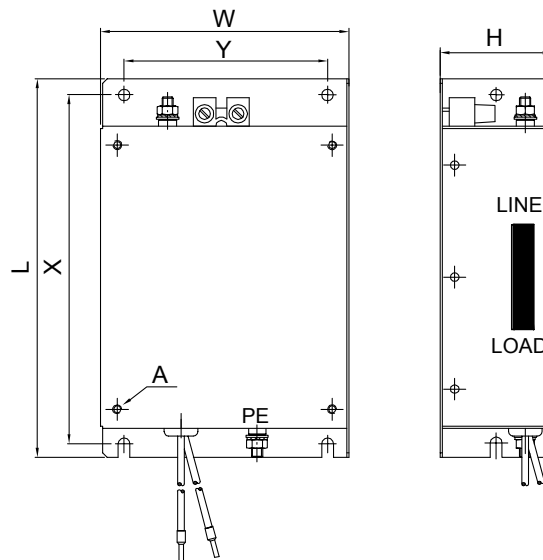


Figure D.3 EMC Filter Dimensions

### ■ DC Link Chokes for IEC/EN 61000-3-2 Compliance

| Drive Model                    | DC Link Choke |                |
|--------------------------------|---------------|----------------|
|                                | Model         | Rating         |
| <b>200V Three-Phase Units</b>  |               |                |
| 2A0004                         | UZDA-B        | 5.4 A<br>8 mH  |
| 2A0006                         |               |                |
| <b>400 V Three-Phase Units</b> |               |                |
| 4A0002                         | UZDA-B        | 3.2 A<br>28 mH |
| 4A0004                         |               |                |

**Note:** Models not listed in the above table do not require a DC link choke for EMC compliance.

## D.3 UL and CSA Standards

### ◆ UL Standards Compliance

The UL/cUL mark applies to products in the United States and Canada and indicates that UL has performed product testing and evaluation and determined that their stringent standards for product safety have been met. For a product to receive UL certification, all components inside that product must also receive UL certification.



Figure D.4 UL/cUL Mark

This drive is tested in accordance with UL standard UL508C and complies with UL requirements. The following conditions must be met to maintain compliance when using this drive in combination with other equipment:

#### ■ Installation Area

Do not install the drive to an area greater than pollution severity 2 (UL standard).

#### ■ Ambient Temperature

IP20/NEMA 1, UL Type 1 enclosure: -10 °C to +40 °C (14 °F to 104 °F)

IP20/IP00 Open-Chassis enclosure: -10 °C to +50 °C (14 °F to 122 °F)

#### ■ Main Circuit Terminal Wiring

Yaskawa recommends using closed-loop crimp terminals on all drive models. UL/cUL approval requires the use of UL Listed closed-loop crimp terminals when wiring the drive main circuit terminals. Use only the tools recommended by the terminal manufacturer for crimping. The wire gauges listed in [Table D.6](#), [Table D.7](#), and [Table D.8](#) are Yaskawa recommendations. Refer to local codes for proper wire gauge selections.

Table D.6 Wire Gauge and Torque Specifications

| Drive Model                | Terminal         | Recomm. Gauge<br>AWG, kcmil | Wire Range<br>AWG, kcmil | Screw Size | Tightening Torque<br>N·m (lb.in.) |
|----------------------------|------------------|-----------------------------|--------------------------|------------|-----------------------------------|
| BA0001<br>BA0002<br>BA0003 | R/L1, S/L2, T/L3 | 14                          | 18 to 14                 | M3.5       | 0.8 to 1.0<br>(7.1 to 8.9)        |
|                            | U/T1, V/T2, W/T3 | 14                          | 18 to 14                 |            |                                   |
|                            | ⊖, ⊕1, ⊕2        | –                           | 18 to 14                 |            |                                   |
|                            | B1, B2           | –                           | 18 to 14                 |            |                                   |
|                            | ⊕                | 14                          | 18 to 14                 |            |                                   |
| BA0006                     | R/L1, S/L2, T/L3 | 12                          | 14 to 10                 | M4         | 1.2 to 1.5<br>(10.6 to 13.3)      |
|                            | U/T1, V/T2, W/T3 | 14                          | 14 to 10                 |            |                                   |
|                            | ⊖, ⊕1, ⊕2        | –                           | 14 to 10                 |            |                                   |
|                            | B1, B2           | –                           | 14 to 10                 |            |                                   |
|                            | ⊕                | 10                          | 14 to 10                 |            |                                   |
| BA0010                     | R/L1, S/L2, T/L3 | 10                          | 14 to 10                 | M4         | 1.2 to 1.5<br>(10.6 to 13.3)      |
|                            | U/T1, V/T2, W/T3 | 14                          | 14 to 10                 |            |                                   |
|                            | ⊖, ⊕1, ⊕2        | –                           | 14 to 10                 |            |                                   |
|                            | B1, B2           | –                           | 14 to 10                 |            |                                   |
|                            | ⊕                | 10                          | 14 to 10                 |            |                                   |
| BA0012                     | R/L1, S/L2, T/L3 | 10                          | 14 to 10                 | M4         | 2.3 to 2.5<br>(20.4 to 22.1)      |
|                            | U/T1, V/T2, W/T3 | 14                          | 14 to 10                 |            |                                   |
|                            | ⊖, ⊕1, ⊕2        | –                           | 14 to 10                 |            |                                   |
|                            | B1, B2           | –                           | 14 to 10                 |            |                                   |
|                            | ⊕                | 10                          | 14 to 10                 |            |                                   |

### D.3 UL and CSA Standards

| Drive Model | Terminal         | Recomm. Gauge AWG, kcmil | Wire Range AWG, kcmil | Screw Size | Tightening Torque N•m (lb.in.) |
|-------------|------------------|--------------------------|-----------------------|------------|--------------------------------|
| BA0018      | R/L1, S/L2, T/L3 | 8                        | 12 to 8               | M5         | 2.3 to 2.5<br>(20.4 to 22.1)   |
|             | U/T1, V/T2, W/T3 | 10                       | 12 to 8               |            |                                |
|             | ⊖, ⊕1, ⊕2        | –                        | 12 to 8               |            |                                |
|             | B1, B2           | –                        | 12 to 8               |            |                                |
|             | ⊕                | 8                        | 12 to 8               |            | 2 to 2.5<br>(17.7 to 22.1)     |

**Table D.7 Wire Gauge and Torque Specifications**

| Drive Model                          | Terminal         | Recomm. Gauge AWG, kcmil | Wire Range AWG, kcmil | Screw Size | Tightening Torque N•m (lb.in.) |
|--------------------------------------|------------------|--------------------------|-----------------------|------------|--------------------------------|
| 2A0001<br>2A0002<br>2A0004<br>2A0006 | R/L1, S/L2, T/L3 | 14                       | 18 to 14              | M3.5       | 0.8 to 1.0<br>(7.1 to 8.9)     |
|                                      | U/T1, V/T2, W/T3 | 14                       | 18 to 14              |            |                                |
|                                      | ⊖, ⊕1, ⊕2        | –                        | 18 to 14              |            |                                |
|                                      | B1, B2           | –                        | 18 to 14              |            |                                |
|                                      | ⊕                | 14                       | 18 to 14              |            |                                |
| 2A0010                               | R/L1, S/L2, T/L3 | 12                       | 14 to 10              | M4         | 1.2 to 1.5<br>(10.6 to 13.3)   |
|                                      | U/T1, V/T2, W/T3 | 14                       | 14 to 10              |            |                                |
|                                      | ⊖, ⊕1, ⊕2        | –                        | 14 to 10              |            |                                |
|                                      | B1, B2           | –                        | 14 to 10              |            |                                |
|                                      | ⊕                | 10                       | 14 to 10              |            |                                |
| 2A0012                               | R/L1, S/L2, T/L3 | 12                       | 14 to 10              | M4         | 1.2 to 1.5<br>(10.6 to 13.3)   |
|                                      | U/T1, V/T2, W/T3 | 14                       | 14 to 10              |            |                                |
|                                      | ⊖, ⊕1, ⊕2        | –                        | 14 to 10              |            |                                |
|                                      | B1, B2           | –                        | 14 to 10              |            |                                |
|                                      | ⊕                | 10                       | 14 to 10              |            |                                |
| 2A0020                               | R/L1, S/L2, T/L3 | 10                       | 14 to 10              | M4         | 1.2 to 1.5<br>(10.6 to 13.3)   |
|                                      | U/T1, V/T2, W/T3 | 10                       | 14 to 10              |            |                                |
|                                      | ⊖, ⊕1, ⊕2        | –                        | 14 to 10              |            |                                |
|                                      | B1, B2           | –                        | 14 to 10              |            |                                |
|                                      | ⊕                | 10                       | 14 to 10              |            |                                |
| 2A0030                               | R/L1, S/L2, T/L3 | 8                        | 10 to 6               | M4         | 2.1 to 2.3<br>(18.6 to 20.4)   |
|                                      | U/T1, V/T2, W/T3 | 8                        | 10 to 6               |            |                                |
|                                      | ⊖, ⊕1, ⊕2        | –                        | 10 to 6               |            |                                |
|                                      | B1, B2           | –                        | 14 to 10              |            |                                |
|                                      | ⊕                | 8 </>                    | 10 to 6               | M5         | 2 to 2.5<br>(17.7 to 22.1)     |
| 2A0040                               | R/L1, S/L2, T/L3 | 6                        | 10 to 6               | M4         | 2.1 to 2.3<br>(18.6 to 20.4)   |
|                                      | U/T1, V/T2, W/T3 | 8                        | 10 to 6               |            |                                |
|                                      | –, +1, +2        | –                        | 10 to 6               |            |                                |
|                                      | B1, B2           | –                        | 14 to 10              |            |                                |
|                                      | ⊕                | 6                        | 10 to 6               | M5         | 2 to 2.5<br>(17.7 to 22.1)     |
| 2A0056                               | R/L1, S/L2, T/L3 | 4                        | 6 to 4                | M6         | 5.4 to 6.0<br>(47.8 to 53.1)   |
|                                      | U/T1, V/T2, W/T3 | 4                        | 6 to 4                |            |                                |
|                                      | ⊖, ⊕1, ⊕2        | –                        | 6 to 4                |            |                                |
|                                      | B1, B2           | –                        | 10 to 6               | M5         | 2.7 to 3.0<br>(23.9 to 26.6)   |
|                                      | ⊕                | 6                        | 8 to 4                | M6         | 5.4 to 6.0<br>(47.8 to 53.1)   |

| Drive Model | Terminal         | Recomm. Gauge AWG, kcmil | Wire Range AWG, kcmil | Screw Size | Tightening Torque N•m (lb.in.) |
|-------------|------------------|--------------------------|-----------------------|------------|--------------------------------|
| 2A0069      | R/L1, S/L2, T/L3 | 3                        | 8 to 2                | M8         | 9.9 to 11<br>(87.6 to 97.4)    |
|             | U/T1, V/T2, W/T3 | 3                        | 8 to 2                |            |                                |
|             | ⊖, ⊕1, ⊕2        | –                        | 8 to 2                |            |                                |
|             | B1, B2           | –                        | 8 to 6                | M5         | 2.7 to 3.0<br>(23.9 to 26.6)   |
|             | ⊕                | 6                        | 6 to 4                | M6         | 5.4 to 6.0<br>(47.8 to 53.1)   |

<1> When an EMC filter is installed, additional measures must be taken to comply with IEC/EN 61800-5-1. *Refer to EMC Filter Installation on page 424* for details.

**Table D.8 Wire Gauge and Torque Specifications**

| Drive Model                | Terminal         | Recomm. Gauge AWG, kcmil | Wire Range AWG, kcmil | Screw Size | Tightening Torque N•m (lb.in.) |
|----------------------------|------------------|--------------------------|-----------------------|------------|--------------------------------|
| 4A0001<br>4A0002<br>4A0004 | R/L1, S/L2, T/L3 | 14                       | 14 to 10              | M4         | 1.2 to 1.5<br>(10.6 to 13.3)   |
|                            | U/T1, V/T2, W/T3 | 14                       | 14 to 10              |            |                                |
|                            | ⊖, ⊕1, ⊕2        | –                        | 14 to 10              |            |                                |
|                            | B1, B2           | –                        | 14 to 10              |            |                                |
|                            | ⊕                | 14                       | 14 to 10              |            |                                |
| 4A0005<br>4A0007<br>4A0009 | R/L1, S/L2, T/L3 | 14                       | 14 to 10              | M4         | 1.2 to 1.5<br>(10.6 to 13.3)   |
|                            | U/T1, V/T2, W/T3 | 14                       | 14 to 10              |            |                                |
|                            | ⊖, ⊕1, ⊕2        | –                        | 14 to 10              |            |                                |
|                            | B1, B2           | –                        | 14 to 10              |            |                                |
|                            | ⊕                | 10                       | 14 to 10              |            |                                |
| 4A0011                     | R/L1, S/L2, T/L3 | 12                       | 14 to 10              | M4         | 1.2 to 1.5<br>(10.6 to 13.3)   |
|                            | U/T1, V/T2, W/T3 | 14                       | 14 to 10              |            |                                |
|                            | ⊖, ⊕1, ⊕2        | –                        | 14 to 10              |            |                                |
|                            | B1, B2           | –                        | 14 to 10              |            |                                |
|                            | ⊕                | 10                       | 14 to 10              |            |                                |
| 4A0018                     | R/L1, S/L2, T/L3 | 10                       | 14 to 6               | M4         | 2.1 to 2.3<br>(18.6 to 20.4)   |
|                            | U/T1, V/T2, W/T3 | 10                       | 14 to 6               |            |                                |
|                            | ⊖, ⊕1, ⊕2        | –                        | 14 to 6               |            |                                |
|                            | B1, B2           | –                        | 14 to 10              | M5         | 2 to 2.5<br>(17.7 to 22.1)     |
|                            | ⊕                | 8                        | 14 to 6               |            |                                |
| 4A0023                     | R/L1, S/L2, T/L3 | 10                       | 10 to 6               | M4         | 2.1 to 2.3<br>(18.6 to 20.4)   |
|                            | U/T1, V/T2, W/T3 | 10                       | 10 to 6               |            |                                |
|                            | ⊖, ⊕1, ⊕2        | –                        | 10 to 6               |            |                                |
|                            | B1, B2           | –                        | 14 to 10              | M5         | 2 to 2.5<br>(17.7 to 22.1)     |
|                            | ⊕                | 8                        | 10 to 6               |            |                                |
| 4A0031                     | R/L1, S/L2, T/L3 | 8                        | 10 to 6               | M5         | 3.6 to 4.0<br>(31.8 to 35.4)   |
|                            | U/T1, V/T2, W/T3 | 8                        | 10 to 6               |            |                                |
|                            | ⊖, ⊕1, ⊕2        | –                        | 10 to 6               |            |                                |
|                            | B1, B2           | –                        | 14 to 10              | M6         | 2.7 to 3.0<br>(23.9 to 26.6)   |
|                            | ⊕                | 6 <1>                    | 10 to 6               |            |                                |

## D.3 UL and CSA Standards

| Drive Model | Terminal         | Recomm. Gauge<br>AWG, kcmil | Wire Range<br>AWG, kcmil | Screw Size | Tightening Torque<br>N•m (lb.in.) |
|-------------|------------------|-----------------------------|--------------------------|------------|-----------------------------------|
| 4A0038      | R/L1, S/L2, T/L3 | 6                           | 10 to 6                  | M5         | 3.6 to 4.0<br>(31.8 to 35.4)      |
|             | U/T1, V/T2, W/T3 | 8                           | 10 to 6                  |            |                                   |
|             | ⊖, ⊕1, ⊕2        | –                           | 10 to 6                  |            |                                   |
|             | B1, B2           | –                           | 10 to 8                  | M6         | 2.7 to 3.0<br>(23.9 to 26.6)      |
|             | ⊕                | 6                           | 10 to 6                  |            |                                   |

<1> When an EMC filter is installed, additional measures must be taken to comply with IEC/EN 61800-5-1. [Refer to EMC Filter Installation on page 424](#) for details.

**Note:** Use crimp insulated terminals or insulated tubing for wiring these connections. Wires should have a continuous maximum allowable temperature of 75 °C 600 V UL approved vinyl sheathed insulation. Ambient temperature should not exceed 30 °C.

### Closed-Loop Crimp Terminal Recommendations

Yaskawa recommends crimp terminals made by JST and Tokyo DIP for the insulation cap.

[Table D.9](#) matches the wire gauges and terminal screw sizes with Yaskawa-recommended crimp terminals, tools, and insulation caps. Refer to the appropriate Wire Gauge and Torque Specifications table for the wire gauge and screw size for your drive model. Place orders with a Yaskawa representative or the Yaskawa sales department.

The closed-loop crimp terminal sizes and values listed in [Table D.9](#) are Yaskawa recommendations. Refer to local codes for proper selections.

**Table D.9 Closed-Loop Crimp Terminal Sizes**

| Wire Gauge  | Terminal Screws | Crimp Terminal Model Number | Tool        |         | Insulation Cap Model No. | Code <1>    |
|-------------|-----------------|-----------------------------|-------------|---------|--------------------------|-------------|
|             |                 |                             | Machine No. | Die Jaw |                          |             |
| 18 AWG      | M3.5            | R1.25-3.5                   | YA-4        | AD-900  | TP-003                   | 100-066-217 |
| 16 AWG      | M3.5            | R1.25-3.5                   | YA-4        | AD-900  | TP-003                   | 100-066-217 |
| 14 AWG      | M3.5            | R2-3.5                      | YA-4        | AD-900  | TP-003                   | 100-066-218 |
|             | M4              | R2-4                        | YA-4        | AD-900  | TP-003                   | 100-054-028 |
| 12 / 10 AWG | M4              | R5.5-4                      | YA-4        | AD-900  | TP-005                   | 100-054-029 |
|             | M5              | R5.5-5                      | YA-4        | AD-900  | TP-005                   | 100-054-030 |
| 8 AWG       | M4              | 8-4                         | YA-4        | AD-901  | TP-008                   | 100-054-031 |
|             | M5              | R8-5                        | YA-4        | AD-901  | TP-008                   | 100-054-032 |
|             | M8              | R8-8                        | YA-4        | AD-901  | TP-008                   | 100-061-111 |
| 6 AWG       | M4              | 14-4                        | YA-4        | AD-902  | TP-014                   | 100-66-220  |
|             | M5              | R14-5                       | YA-4        | AD-902  | TP-014                   | 100-054-034 |
|             | M6              | R14-6                       | YA-5        | AD-952  | TP-014                   | 100-051-261 |
|             | M8              | R14-8                       | YA-5        | AD-952  | TP-014                   | 100-054-035 |
| 4 AWG       | M6              | R22-6                       | YA-5        | AD-953  | TP-022                   | 100-051-262 |
|             | M8              | R22-8                       | YA-5        | AD-953  | TP-022                   | 100-051-263 |
| 3 AWG       | M8              | R38-8                       | YA-5        | AD-954  | TP-038                   | 100-051-264 |
| 2 AWG       | M8              | R38-8                       | YA-5        | AD-954  | TP-038                   | 100-051-264 |

<1> Codes refer to a set of three crimp terminals and three insulation caps. Prepare input and output wiring using two sets for each connection.

Example: Models with 14 AWG for both input and output require one set for input terminals and one set for output terminals, so the user should order two sets of [100-066-218].

**Note:** Consider the amount of voltage drop when selecting wire gauges. Increase the wire gauge when the voltage drop is greater than 2% of motor rated voltage. Ensure the wire gauge is suitable for the terminal block. Use the following formula to calculate the amount of voltage drop: Line drop voltage (V) =  $\sqrt{3} \times \text{wire resistance } (\Omega/\text{km}) \times \text{wire length (m)} \times \text{current (A)} \times 10^{-3}$

### Factory Recommended Branch Circuit Protection

Yaskawa recommends installing one of the following types of branch circuit protection to maintain compliance with UL508C. Semiconductor protective type fuses are preferred.

Branch circuit protection shall be provided by any of the following according to [Table D.10](#).

- Non-time Delay Class J, T, or CC fuses.
- Time Delay Class J, T, CC, or RK5 fuses.

- Semiconductor fuses.
- Molded Case Circuit Breakers (MCCB).

**Table D.10 Factory Recommended Drive Branch Circuit Protection**

| Drive Model                            | Non-time Delay Fuse Rating (A) <1> | Time Delay Fuses                      |                               | Bussmann Semiconductor Fuse Part Number (Fuse Ampere) <4> | MCCB <5>   |   |
|--|------------------------------------|---------------------------------------|-------------------------------|---|------------|---|
|  |                                    | Class J, T, or CC Fuse Rating (A) <2> | Class RK5 Fuse Rating (A) <3> |   | Rating (A) | Minimum Enclosure Volume (in <sup>3</sup> ) |
| <b>200 V Class Single-Phase Drives</b> |                                    |                                       |                               |   |            |   |
| BA0001                                 | 6                                  | 3.5                                   | 4                             | FWH-25A14F (25)   | 15         | 600   |
| BA0002                                 | 10                                 | 6                                     | 8                             | FWH-25A14F (25)   | 15         | 600   |
| BA0003                                 | 20                                 | 10                                    | 15                            | FWH-60B (60)  | 15         | 600   |
| BA0006                                 | 40                                 | 20                                    | 30                            | FWH-80B (80)  | 30         | 1152  |
| BA0010                                 | 40                                 | 35                                    | 45                            | FWH-100B (100)  | 50         | 1152  |
| <b>200 V Class Three-Phase Drives</b>  |                                    |                                       |                               |   |            |   |
| 2A0001                                 | 3                                  | 1.5                                   | 2                             | FWH-25A14F (25)   | 15         | 600   |
| 2A0002                                 | 6 <6>                              | 3                                     | 3                             | FWH-25A14F (25)   | 15         | 600   |
| 2A0004                                 | 15 <7>                             | 6                                     | 8                             | FWH-25A14F (25)   | 15         | 600   |
| 2A0006                                 | 20                                 | 10                                    | 15                            | FWH-25A14F (25)   | 15         | 1152  |
| 2A0010                                 | 25                                 | 15                                    | 20                            | FWH-70B (70)  | 25         | 1152  |
| 2A0012                                 | 25                                 | 20                                    | 30                            | FWH-70B (70)  | 30         | 1152  |
| 2A0020                                 | 40                                 | 40                                    | 50                            | FWH-90B (90)  | 60         | 1152  |
| <b>400 V Class Three-Phase Drives</b>  |                                    |                                       |                               |   |            |   |
| 4A0001                                 | 3                                  | 2                                     | 2                             | FWH-40B (40)  | 15         | 1152  |
| 4A0002                                 | 6                                  | 3.5                                   | 3                             | FWH-40B (40)  | 15         | 1152  |
| 4A0004                                 | 15 <7>                             | 7                                     | 8                             | FWH-50B (50)  | 15         | 1152  |
| 4A0005                                 | 20 <8>                             | 10                                    | 10                            | FWH-70B (70)  | 15         | 1152  |
| 4A0007                                 | 25 <9>                             | 12                                    | 15                            | FWH-70B (70)  | 20         | 1152  |
| 4A0009                                 | 25                                 | 15                                    | 20                            | FWH-90B (90)  | 20         | 1152  |
| 4A0011                                 | 30                                 | 20                                    | 30                            | FWH-90B (90)  | 35         | 1152  |

- <1> Maximum 300% of drive input current rating for any Class J, T, or CC fuse except for models 2A0002, 2A0004, 4A0004, 4A0005, and 4A0007.
- <2> Maximum 175% of drive input current rating for any Class J, T, or CC fuse.
- <3> Maximum 225% of drive input current rating for any Class RK5 fuse.
- <4> When using semiconductor fuses, Bussmann FWH are required for UL compliance.
- <5> Maximum MCCB Rating is 15 A or 200% of drive input current rating, whichever is larger. MCCB voltage rating must be 600 Vac or greater. Additionally, when using MCCBs for protection, the drive must be installed in a ventilated enclosure with minimum volume according the “Minimum Enclosure Volume” column.
- <6> Model 2A0002 requires Mersen (Ferraz) part number A6T6 for compliance.
- <7> Models 2A0004 and 4A0004 require Mersen (Ferraz) part number A6T15 for compliance.
- <8> Model 4A0005 requires Mersen (Ferraz) part number A6T20 for compliance.
- <9> Model 4A0007 requires Mersen (Ferraz) part number A6T25 for compliance.

**■ Low Voltage Wiring for Control Circuit Terminals**

Wire low voltage wires with NEC Class 1 circuit conductors. Refer to national state or local codes for wiring. The external power supply shall be a UL-Listed Class 2 power source or equivalent.

**■ Drive Short-Circuit Rating**

This drive has undergone the UL short-circuit test, which certifies that during a short circuit in the power supply the current flow will not rise above 31,000 amps maximum at 240 V for 200 V class drives and 480 V for 400 V class drives.

- The MCCB and breaker protection and fuse ratings shall be equal to or greater than the short-circuit tolerance of the power supply being used.
- Suitable for use on a circuit capable of delivering not more than 31,000 RMS symmetrical amperes for 240 V in 200 V class drives (up to 480 V for 400 V class drives) motor overload protection.

### ◆ CSA Standards Compliance



Figure D.5 CSA Mark

#### ■ CSA for Industrial Control Equipment

The drive is CSA-certified as Industrial Control Equipment Class 3211.

Specifically, the drive is certified to: CAN/CSA C22.2 No. 04-04 and CAN/CSA C22.2 No.14-05.

---

### ◆ Drive Motor Overload Protection

Set parameter E2-01 (motor rated current) to the appropriate value to enable motor overload protection. The internal motor overload protection is UL listed and in accordance with the NEC and CEC.

#### ■ E2-01: Motor Rated Current

Setting Range: Model Dependent

Default Setting: Model Dependent

Parameter E2-01 (motor rated current) protects the motor if parameter L1-01 is not set to 0 (default is 1, standard induction motor protection enabled).

#### ■ L1-01: Motor Overload Protection Selection

The drive has an electronic overload protection function (oL1) based on time, output current and output frequency, which protects the motor from overheating. The electronic thermal overload function is UL-recognized, so it does not require an external thermal overload relay for single motor operation.

This parameter selects the motor overload curve used according to the type of motor applied.

Disable the electronic overload protection (L1-01 = 0: Disabled) and wire each motor with its own motor thermal overload when connecting the drive to more than one motor for simultaneous operation.

Enable the motor overload protection (L1-01 = "1", "2", or "3") when connecting the drive to a single motor unless there is another means of preventing motor thermal overload. The electronic thermal overload function causes an oL1 fault, which shuts off the output of the drive and prevents additional overheating of the motor. The motor temperature is continually calculated as long as the drive is powered up.

#### ■ L1-02: Motor Overload Protection Time

Setting Range: 0.1 to 5.0 Minutes

Factory Default: 1.0 Minutes

The L1-02 parameter sets the allowed operation time before the oL1 fault occurs when the drive is running at 60 Hz and 150% of the full load amp rating (E2-01) of the motor. Adjusting the value of L1-02 can shift the set of oL1 curves up the Y-axis of the diagram below but will not change the shape of the curves.



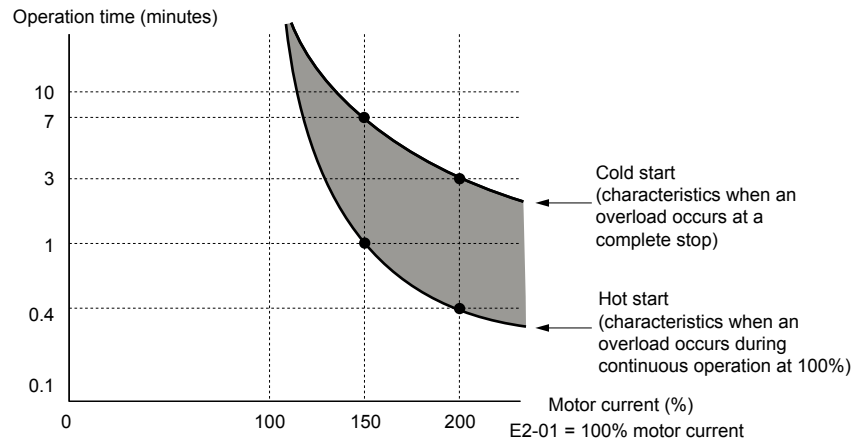


Figure D.6 Motor Overload Protection Time

## ◆ Safe Disable Function Description

The Safe Disable function can be utilized to perform a safe stop according to the IEC/EN 61800-5-2, stop category 0 (Uncontrolled stop by power removal). It is designed to meet the requirements of the ISO/EN 13849-1, Safety Category 3, PL d, and IEC/EN 61508, SIL2.

Removing the voltage from terminal H1 disables the drive output, i.e. the power supply to the motor is cut by stopping the switching of the output transistors in a safe way. “Hbb” is shown on the display. Safe Disable is applicable for induction and permanent magnet motors.

## ◆ Installation

If the Safe Disable function is utilized, the wire link between the terminals HC and H1 that is installed at shipment must be removed entirely.

Connect the drive to an ISO/EN 13849-1, Safety Category 3 interrupting device so that in case of a Safe Disable request the connection between the terminals HC and H1 is opened.

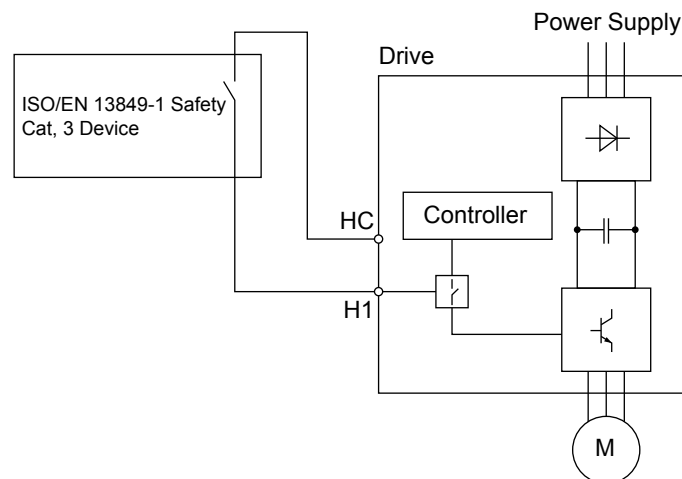


Figure D.7 Safe Disable Wiring Example

## ■ Installation Precautions

- To ensure the Safe Disable function appropriately fulfills the safety requirements of the application, a thorough risk assessment for the safety system must be carried out.
- The drive must be installed in an enclosure with a protection degree of at least IP54 in order to maintain ISO/EN 13849-1, safety category 3 compliance.
- If the safety device and the drive are installed in separate cabinets, install the Safe Disable wires in a manner preventing short circuits.

### D.3 UL and CSA Standards

---

- The Safe Disable function does not cut the power supply to the drive and does not provide electrical isolation. Before any installation or maintenance work is done, the power supply of the drive must be switched off.
- Consider the following when using PM motors: When the Safe Disable function is active, a failure in two of the drive power devices can occur and current will continue to flow through the motor winding. This failure will not produce torque in an induction motor, however, when occurring in a PM motor, torque will be produced and cause an alignment of the rotor magnets, which may cause the rotor to turn up to 180 degrees electrically. Ensure that this possible failure mode is not safety-critical for the application.
- The wiring distance for the Safe Disable inputs should not exceed 30 m.
- The time from opening the Safe Disable input until the drive output is switched off is less than 1 ms.

## D.1 UL Standards

### ◆ UL Standards Compliance

The UL/cUL mark applies to products in the United States and Canada and indicates that UL has performed product testing and evaluation and determined that their stringent standards for product safety have been met. For a product to receive UL certification, all components inside that product must also receive UL certification.



Figure D.8 UL/cUL Mark

This drive is tested in accordance with UL standard UL508C and complies with UL requirements. The following conditions must be met to maintain compliance when using this drive in combination with other equipment:

#### ■ Installation Area

Do not install the drive to an area greater than pollution severity 2 (UL standard).

#### ■ Ambient Temperature

IP20/NEMA 1, UL Type 1 enclosure: -10 °C to +40 °C (14 °F to 104 °F)

NEMA 4X, UL Type 4X/IP66 enclosure: -10 °C to +40 °C (14 °F to 104 °F)

### ◆ IP66/NEMA 4X, UL Type 4X Conditions of Acceptability

Adhere to the installation conditions specified in this manual to take full advantage of the IP66/NEMA 4X, UL Type 4X design of this drive.

#### ■ Resistance Against Chemicals and Solvents

*Table D.11* lists the information on chemical and solvent tolerability of the drive. The drive enclosure meets these requirements:

- UL50E: Enclosures for Electrical Equipment, Environmental Considerations **NEMA 4X, UL Type 4X**
- International Standard IEC 60529 Degrees of protection provided by enclosures (IP Code) **IP66**

Refer to the appropriate enclosure specification for more details on the enclosures resistance to chemicals and solvents.

Table D.11 Chemical and Solvent Tolerability

| Reagent   | Solvent   |
|---|---|
| <ul style="list-style-type: none"> <li>• Hydrochloric acid (10%)</li> <li>• Sulfuric acid (10%)</li> <li>• Nitric acid (10%)</li> <li>• Ammonia water</li> <li>• Sodium chloride</li> </ul> | <ul style="list-style-type: none"> <li>• Methanol</li> <li>• Ethanol</li> </ul> |

**NOTICE:** Do not allow a stream of chemicals or solvents to be sprayed directly onto the drive enclosure. Failure to do so can damage the drive.

**NOTICE:** Prevent moisture and other solvents from entering the drive enclosure when removing the front cover. Failing to do so can damage the drive or considerably shorten its expected performance life.

### ◆ Main Circuit Terminal Wiring

Yaskawa recommends using closed-loop crimp terminals on all drive models. UL/cUL approval requires the use of UL Listed closed-loop crimp terminals when wiring the drive main circuit terminals. Use only the tools recommended by the terminal manufacturer for crimping. The wire gauges listed below are Yaskawa recommendations. Refer to local codes for proper wire gauge selections.

■ Single-Phase 200 V Class

Table D.12 Wire Gauge and Torque Specifications

| Drive Model | Terminal         | Recomm. Gauge AWG, kcmil | Wire Range AWG, kcmil | Screw Size | Tightening Torque N•m (lb.in.) |
|-------------|------------------|--------------------------|-----------------------|------------|--------------------------------|
| BV0006      | R/L1, S/L2, T/L3 | 12                       | 14 to 10              | M4         | 1.2 to 1.5<br>(10.6 to 13.3)   |
|             | U/T1, V/T2, W/T3 | 14                       | 14 to 10              |            |                                |
|             | ⊖, ⊕1, ⊕2        | –                        | 14 to 10              |            |                                |
|             | B1, B2           | –                        | 14 to 10              |            |                                |
|             | ⊕                | 10                       | 14 to 10              |            |                                |
| BV0010      | R/L1, S/L2, T/L3 | 10                       | 14 to 10              | M4         | 1.2 to 1.5<br>(10.6 to 13.3)   |
|             | U/T1, V/T2, W/T3 | 14                       | 14 to 10              |            |                                |
|             | ⊖, ⊕1, ⊕2        | –                        | 14 to 10              |            |                                |
|             | B1, B2           | –                        | 14 to 10              |            |                                |
|             | ⊕                | 10                       | 14 to 10              |            |                                |
| BV0012      | R/L1, S/L2, T/L3 | 10                       | 14 to 10              | M4         | 2.3 to 2.5<br>(20.4 to 22.1)   |
|             | U/T1, V/T2, W/T3 | 14                       | 14 to 10              |            |                                |
|             | ⊖, ⊕1, ⊕2        | –                        | 14 to 10              |            |                                |
|             | B1, B2           | –                        | 14 to 10              |            |                                |
|             | ⊕                | 10                       | 14 to 10              |            |                                |
| BV0018      | R/L1, S/L2, T/L3 | 8                        | 12 to 8               | M5         | 2.3 to 2.5<br>(20.4 to 22.1)   |
|             | U/T1, V/T2, W/T3 | 10                       | 12 to 8               |            |                                |
|             | ⊖, ⊕1, ⊕2        | –                        | 12 to 8               |            |                                |
|             | B1, B2           | –                        | 12 to 8               |            |                                |
|             | ⊕                | 8                        | 12 to 8               |            | 2 to 2.5<br>(17.7 to 22.1)     |

■ Three-Phase 200 V Class

Table D.13 Wire Gauge and Torque Specifications

| Drive Model | Terminal         | Recomm. Gauge AWG, kcmil | Wire Range AWG, kcmil | Screw Size | Tightening Torque N•m (lb.in.) |
|-------------|------------------|--------------------------|-----------------------|------------|--------------------------------|
| 2V0006      | R/L1, S/L2, T/L3 | 14                       | 18 to 14              | M3.5       | 0.8 to 1.0<br>(7.1 to 8.9)     |
|             | U/T1, V/T2, W/T3 | 14                       | 18 to 14              |            |                                |
|             | ⊖, ⊕1, ⊕2        | –                        | 18 to 14              |            |                                |
|             | B1, B2           | –                        | 18 to 14              |            |                                |
|             | ⊕                | 14                       | 18 to 14              |            |                                |
| 2V0010      | R/L1, S/L2, T/L3 | 12                       | 14 to 10              | M4         | 1.2 to 1.5<br>(10.6 to 13.3)   |
|             | U/T1, V/T2, W/T3 | 14                       | 14 to 10              |            |                                |
|             | ⊖, ⊕1, ⊕2        | –                        | 14 to 10              |            |                                |
|             | B1, B2           | –                        | 14 to 10              |            |                                |
|             | ⊕                | 10                       | 14 to 10              |            |                                |
| 2V0012      | R/L1, S/L2, T/L3 | 12                       | 14 to 10              | M4         | 1.2 to 1.5<br>(10.6 to 13.3)   |
|             | U/T1, V/T2, W/T3 | 14                       | 14 to 10              |            |                                |
|             | ⊖, ⊕1, ⊕2        | –                        | 14 to 10              |            |                                |
|             | B1, B2           | –                        | 14 to 10              |            |                                |
|             | ⊕                | 10                       | 14 to 10              |            |                                |
| 2V0020      | R/L1, S/L2, T/L3 | 10                       | 14 to 10              | M4         | 1.2 to 1.5<br>(10.6 to 13.3)   |
|             | U/T1, V/T2, W/T3 | 10                       | 14 to 10              |            |                                |
|             | ⊖, ⊕1, ⊕2        | –                        | 14 to 10              |            |                                |
|             | B1, B2           | –                        | 14 to 10              |            |                                |
|             | ⊕                | 10                       | 14 to 10              |            |                                |

| Drive Model | Terminal         | Recomm. Gauge<br>AWG, kcmil | Wire Range<br>AWG, kcmil | Screw Size | Tightening Torque<br>N•m (lb.in.) |
|-------------|------------------|-----------------------------|--------------------------|------------|-----------------------------------|
| 2V0030      | R/L1, S/L2, T/L3 | 8                           | 10 to 6                  | M4         | 2.1 to 2.3<br>(18.6 to 20.4)      |
|             | U/T1, V/T2, W/T3 | 8                           | 10 to 6                  |            |                                   |
|             | ⊖, ⊕1, ⊕2        | –                           | 10 to 6                  |            |                                   |
|             | B1, B2           | –                           | 14 to 10                 |            |                                   |
|             | ⊕                | 8                           | 10 to 6                  | M5         | 2 to 2.5<br>(17.7 to 22.1)        |
| 2V0040      | R/L1, S/L2, T/L3 | 6                           | 10 to 6                  | M4         | 2.1 to 2.3<br>(18.6 to 20.4)      |
|             | U/T1, V/T2, W/T3 | 8                           | 10 to 6                  |            |                                   |
|             | ⊖, ⊕1, ⊕2        | –                           | 10 to 6                  |            |                                   |
|             | B1, B2           | –                           | 14 to 10                 |            |                                   |
|             | ⊕                | 6                           | 10 to 6                  | M5         | 2 to 2.5<br>(17.7 to 22.1)        |
| 2V0056      | R/L1, S/L2, T/L3 | 4                           | 6 to 4                   | M6         | 5.4 to 6.0<br>(47.8 to 53.1)      |
|             | U/T1, V/T2, W/T3 | 4                           | 6 to 4                   |            |                                   |
|             | ⊖, ⊕1, ⊕2        | –                           | 6 to 4                   |            |                                   |
|             | B1, B2           | –                           | 10 to 6                  | M5         | 2.7 to 3.0<br>(23.9 to 26.6)      |
|             | ⊕                | 6                           | 8 to 4                   | M6         | 5.4 to 6.0<br>(47.8 to 53.1)      |
| 2V0069      | R/L1, S/L2, T/L3 | 3                           | 8 to 2                   | M8         | 9.9 to 11<br>(87.6 to 97.4)       |
|             | U/T1, V/T2, W/T3 | 3                           | 8 to 2                   |            |                                   |
|             | ⊖, ⊕1, ⊕2        | –                           | 8 to 2                   |            |                                   |
|             | B1, B2           | –                           | 8 to 6                   | M5         | 2.7 to 3.0<br>(23.9 to 26.6)      |
|             | ⊕                | 6                           | 6 to 4                   | M6         | 5.4 to 6.0<br>(47.8 to 53.1)      |

### ■ Three-Phase 400 V Class

Table D.14 Wire Gauge and Torque Specifications

| Drive Model                | Terminal         | Recomm. Gauge<br>AWG, kcmil | Wire Range<br>AWG, kcmil | Screw Size | Tightening Torque<br>N•m (lb.in.) |
|----------------------------|------------------|-----------------------------|--------------------------|------------|-----------------------------------|
| 4V0002<br>4V0004           | R/L1, S/L2, T/L3 | 14                          | 14 to 10                 | M4         | 1.2 to 1.5<br>(10.6 to 13.3)      |
|                            | U/T1, V/T2, W/T3 | 14                          | 14 to 10                 |            |                                   |
|                            | ⊖, ⊕1, ⊕2        | –                           | 14 to 10                 |            |                                   |
|                            | B1, B2           | –                           | 14 to 10                 |            |                                   |
|                            | ⊕                | 14                          | 14 to 10                 |            |                                   |
| 4V0005<br>4V0007<br>4V0009 | R/L1, S/L2, T/L3 | 14                          | 14 to 10                 | M4         | 1.2 to 1.5<br>(10.6 to 13.3)      |
|                            | U/T1, V/T2, W/T3 | 14                          | 14 to 10                 |            |                                   |
|                            | ⊖, ⊕1, ⊕2        | –                           | 14 to 10                 |            |                                   |
|                            | B1, B2           | –                           | 14 to 10                 |            |                                   |
|                            | ⊕                | 10                          | 14 to 10                 |            |                                   |
| 4V0011                     | R/L1, S/L2, T/L3 | 12                          | 14 to 10                 | M4         | 1.2 to 1.5<br>(10.6 to 13.3)      |
|                            | U/T1, V/T2, W/T3 | 14                          | 14 to 10                 |            |                                   |
|                            | ⊖, ⊕1, ⊕2        | –                           | 14 to 10                 |            |                                   |
|                            | B1, B2           | –                           | 14 to 10                 |            |                                   |
|                            | ⊕                | 10                          | 14 to 10                 |            |                                   |

## D.1 UL Standards

| Drive Model | Terminal         | Recomm. Gauge AWG, kcmil | Wire Range AWG, kcmil | Screw Size | Tightening Torque N•m (lb.in.) |
|-------------|------------------|--------------------------|-----------------------|------------|--------------------------------|
| 4V0018      | R/L1, S/L2, T/L3 | 10                       | 14 to 6               | M4         | 2.1 to 2.3<br>(18.6 to 20.4)   |
|             | U/T1, V/T2, W/T3 | 10                       | 14 to 6               |            |                                |
|             | ⊖, ⊕1, ⊕2        | –                        | 14 to 6               |            |                                |
|             | B1, B2           | –                        | 14 to 10              |            |                                |
|             | ⊕                | 8                        | 14 to 6               | M5         | 2 to 2.5<br>(17.7 to 22.1)     |
| 4V0023      | R/L1, S/L2, T/L3 | 10                       | 10 to 6               | M4         | 2.1 to 2.3<br>(18.6 to 20.4)   |
|             | U/T1, V/T2, W/T3 | 10                       | 10 to 6               |            |                                |
|             | ⊖, ⊕1, ⊕2        | –                        | 10 to 6               |            |                                |
|             | B1, B2           | –                        | 14 to 10              |            |                                |
|             | ⊕                | 8                        | 10 to 6               | M5         | 2 to 2.5<br>(17.7 to 22.1)     |
| 4V0031      | R/L1, S/L2, T/L3 | 8                        | 10 to 6               | M5         | 3.6 to 4.0<br>(31.8 to 35.4)   |
|             | U/T1, V/T2, W/T3 | 8                        | 10 to 6               |            |                                |
|             | ⊖, ⊕1, ⊕2        | –                        | 10 to 6               |            |                                |
|             | B1, B2           | –                        | 14 to 10              |            |                                |
|             | ⊕                | 6                        | 10 to 6               | M6         | 5.4 to 6.0<br>(47.8 to 53.1)   |
| 4V0038      | R/L1, S/L2, T/L3 | 6                        | 10 to 6               | M5         | 3.6 to 4.0<br>(31.8 to 35.4)   |
|             | U/T1, V/T2, W/T3 | 8                        | 10 to 6               |            |                                |
|             | ⊖, ⊕1, ⊕2        | –                        | 10 to 6               |            |                                |
|             | B1, B2           | –                        | 10 to 8               |            |                                |
|             | ⊕                | 6                        | 10 to 6               | M6         | 5.4 to 6.0<br>(47.8 to 53.1)   |

### ■ Factory Recommended Branch Circuit Protection for UL Compliance

Yaskawa recommends installing one of the following types of branch circuit protection to maintain compliance with UL508C. Semiconductor protective type fuses are preferred.

Branch circuit protection shall be provided by any of the following according to [Table D.10](#).

- Non-time Delay Class J, T, or CC fuses.
- Time Delay Class J, T, CC, or RK5 fuses.
- Semiconductor fuses.
- Molded Case Circuit Breakers (MCCB).

**Table D.15 Factory Recommended Drive Branch Circuit Protection**

| Drive Model                            | Non-time Delay Fuse Rating (A)<br><1> | Time Delay Fuses                         |                                  | Bussmann Semiconductor Fuse Part Number (Fuse Ampere) <4> | MCCB <5>   |   |
|--|---------------------------------------|--|----------------------------------|---|------------|---|
|  |                                       | Class J, T, or CC Fuse Rating (A)<br><2> | Class RK5 Fuse Rating (A)<br><3> |   | Rating (A) | Minimum Enclosure Volume (in <sup>3</sup> ) |
| <b>200 V Class Single-Phase Drives</b> |                                       |  |                                  |   |            |   |
| BV0006                                 | 40                                    | 20                                       | 30                               | FWH-80B (80)  | 30         | 1152  |
| BV0010                                 | 40                                    | 35                                       | 45                               | FWH-100B (100)  | 50         | 1152  |
| BV0012                                 | 50                                    | 40                                       | 50                               | FWH-125B (125)  | 60         | 1152  |
| BV0018                                 | 80                                    | 60                                       | 70                               | FWH-175B (175)  | 80         | 1152  |
| <b>200 V Class Three-Phase Drives</b>  |                                       |  |                                  |   |            |   |
| 2V0006                                 | 20                                    | 10                                       | 15                               | FWH-25A14F (25)   | 15         | 1152  |
| 2V0010                                 | 25                                    | 15                                       | 20                               | FWH-70B (70)  | 25         | 1152  |
| 2V0012                                 | 25                                    | 20                                       | 30                               | FWH-70B (70)  | 30         | 1152  |
| 2V0020                                 | 40                                    | 40                                       | 50                               | FWH-90B (90)  | 60         | 1152  |
| 2V0030                                 | –                                     | 60                                       | 80                               | FWH-100B (100)  | 90         | 1152  |

| Drive Model                    | Non-time Delay Fuse Rating (A) <1> | Time Delay Fuses                      |                               | Bussmann Semiconductor Fuse Part Number (Fuse Ampere) <4> | MCCB <5>   |   |
|--------------------------------|------------------------------------|---------------------------------------|-------------------------------|---|------------|---|
|                                |                                    | Class J, T, or CC Fuse Rating (A) <2> | Class RK5 Fuse Rating (A) <3> |   | Rating (A) | Minimum Enclosure Volume (in <sup>3</sup> ) |
| 2V0040                         | –                                  | 90                                    | 110                           | FWH-200B (200)  | 125        | 1152  |
| 2V0056                         | –                                  | 110                                   | 150                           | FWH-200B (200)  | 150        | 2560  |
| 2V0069                         | –                                  | 125                                   | 175                           | FWH-200B (200)  | 200        | 2560  |
| 400 V Class Three-Phase Drives |                                    |                                       |                               |   |            |   |
| 4V0002                         | 6                                  | 3.5                                   | 3                             | FWH-40B (40)  | 15         | 1152  |
| 4V0004                         | 15 <7>                             | 7                                     | 8                             | FWH-50B (50)  | 15         | 1152  |
| 4V0005                         | 20 <8>                             | 10                                    | 10                            | FWH-70B (70)  | 15         | 1152  |
| 4V0007                         | 25 <9>                             | 12                                    | 15                            | FWH-70B (70)  | 20         | 1152  |
| 4V0009                         | 25                                 | 15                                    | 20                            | FWH-90B (90)  | 20         | 1152  |
| 4V0011                         | 30                                 | 20                                    | 30                            | FWH-90B (90)  | 35         | 1152  |
| 4V0018                         | –                                  | 35                                    | 45                            | FWH-80B (80)  | 50         | 1152  |
| 4V0023                         | –                                  | 40                                    | 50                            | FWH-100B (100)  | 60         | 1152  |
| 4V0031                         | –                                  | 60                                    | 80                            | FWH-125B (125)  | 90         | 1152  |
| 4V0038                         | –                                  | 70                                    | 90                            | FWH-200B (200)  | 110        | 1152  |

<1> Maximum 300% of drive input current rating for any Class J, T, or CC fuse except for models 4V0004, 4V0005, and 4V0007.

<2> Maximum 175% of drive input current rating for any Class J, T, or CC fuse.

<3> Maximum 225% of drive input current rating for any Class RK5 fuse.

<4> When using semiconductor fuses, Bussmann FWH are required for UL compliance.

<5> Maximum MCCB Rating is 15 A or 200% of drive input current rating, whichever is larger. MCCB voltage rating must be 600 Vac or greater. Additionally, when using MCCBs for protection, the drive must be installed in a ventilated enclosure with minimum volume according the “Minimum Enclosure Volume” column.

<6> Model 4V0004 requires Mersen (Ferraz) part number A6T15 for compliance.

<7> Model 4V0005 requires Mersen (Ferraz) part number A6T20 for compliance.

<8> Model 4V0007 requires Mersen (Ferraz) part number A6T25 for compliance.

## ■ Low Voltage Wiring for Control Circuit Terminals

Wire low voltage wires with NEC Class 1 circuit conductors. Refer to national state or local codes for wiring. The external power supply shall be a UL-Listed Class 2 power source or equivalent.

**Table D.16 Control Circuit Terminal Power Supply**

| Input / Output                     | Terminal Signal                | Power Supply Specifications   |
|------------------------------------|--------------------------------|---|
| Multi-function photocoupler output | P1, P2, PC                     | Requires class 2 power supply   |
| Multi-function digital inputs      | S1, S2, S3, S4, S5, S6, S7, SC | Use the internal power supply of the drive. Use class 2 for external power supply.      |
| Multi-function analog inputs       | A1, A2, AC                     | Use the internal power supply of the drive. Use class 2 for external power supply.      |
| Pulse train input                  | RP                             | Use the internal LVLC power supply of the drive. Use class 2 for external power supply. |
| Pulse train output                 | MP                             | Use the internal LVLC power supply of the drive. Use class 2 for external power supply. |

## ■ Drive Short-Circuit Rating

This drive has undergone the UL short-circuit test, which certifies that during a short circuit in the power supply the current flow will not rise above 31,000 amps maximum at 240 V for 200 V class drives and 480 V for 400 V class drives.

- The MCCB and breaker protection and fuse ratings shall be equal to or greater than the short-circuit tolerance of the power supply being used.
- Suitable for use on a circuit capable of delivering not more than 31,000 RMS symmetrical amperes for 240 V in 200 V class drives (up to 480 V for 400 V class drives) motor overload protection.

## ◆ Drive Motor Overload Protection

Set parameter E2-01 (motor rated current) to the appropriate value to enable motor overload protection. The internal motor overload protection is UL listed and in accordance with the NEC and CEC.

### ■ E2-01: Motor Rated Current

Setting Range: Model Dependent

Default Setting: Model Dependent

Parameter E2-01 (motor rated current) protects the motor if parameter L1-01 is not set to 0 (default is 1, standard induction motor protection enabled).

If Auto-Tuning has been performed successfully, the motor data that was entered in T1-04 is automatically written into parameter E2-01. If Auto-Tuning has not been performed, manually enter the correct motor rated current in parameter E2-01.

### ■ L1-01: Motor Overload Protection Selection

The drive has an electronic overload protection function (oL1) based on time, output current and output frequency, which protects the motor from overheating. The electronic thermal overload function is UL-recognized, so it does not require an external thermal overload relay for single motor operation.

This parameter selects the motor overload curve used according to the type of motor applied.

Table D.17 Overload Protection Settings

| Setting | Description                                 |
|---------|---|
| 0       | Disabled                                    |
| 1       | Standard Fan-Cooled Motor (Default)         |
| 2       | Drive Duty Motor with a Speed Range of 1:10 |
| 3       | Vector Motor with a Speed Range of 1:100    |
| 6       | Standard Fan-Cooled Motor (50 Hz)           |

Set L1-01 to 0 to disable the electronic overload protection and wire each motor with its own motor thermal overload when connecting the drive to more than one motor for simultaneous operation.

Set L1-01 to 1, 2, or 3 to enable the motor overload protection when connecting the drive to a single motor unless there is another means of preventing motor thermal overload. The electronic thermal overload function will cause an oL1 fault and shut off the output of the drive and prevent further overheating of the motor. The motor temperature is continually calculated while the drive is powered up.

### ■ L1-02: Motor Overload Protection Time

Setting Range: 0.1 to 5.0 Minutes

Factory Default: 1.0 Minutes

The L1-02 parameter sets the allowed operation time before the oL1 fault occurs when the drive is running at 60 Hz and 150% of the full load amp rating (E2-01) of the motor. Adjusting the value of L1-02 can shift the set of oL1 curves up the Y-axis of the diagram below but will not change the shape of the curves.

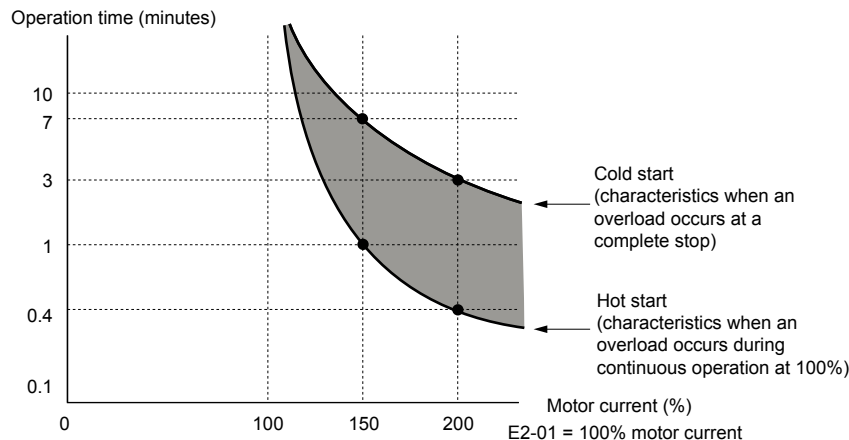


Figure D.9 Motor Overload Protection Time



**This Page Intentionally Blank**

## Revision History

The revision dates and the numbers of the revised manuals appear on the bottom of the back cover.

Example:

MANUAL NO. TOEP YAIQPM 03B

Published in USA    September 2015    14-12    2

Revision number  
Date of original publication  
Date of publication

| Date of Publication | Revision Number | Section    | Revised Content   |
|---------------------|-----------------|------------|---|
| September 2015      | <2>             | All        | Revision: Revised NEMA/UL nomenclature to meet UL standards.<br>Addition: Safety Section to the beginning of chapters |
|                     |                 | Chapter 5  | Addition: Parameter Details chapter   |
|                     |                 | Chapter 6  | Addition: LED and LCD displays to tables  |
|                     |                 | Appendix C | Addition: MEMOBUS/Modbus Communication appendix   |
| March 2015          | <1>             | Appendix D | Revision: Factory Recommended Branch Circuit Protection for UL Compliance   |
| December 2014       | -               | -          | First Edition. This manual supports drive software version PRG: 0100.   |



# iQpump Micro AC Drive

## Compact Intelligent Pump Controller

### User Manual

---

**YASKAWA AMERICA, INC.**

2121, Norman Drive South, Waukegan, IL 60085, U.S.A.  
Phone: 1-800-YASKAWA (927-5292) or 1-847-887-7000 Fax: 1-847-887-7310  
<http://www.yaskawa.com>

**DRIVE CENTER (INVERTER PLANT)**

2-13-1, Nishimiyaichi, Yukuhashi, Fukuoka, 824-8511, Japan  
Phone: 81-930-25-3844 Fax: 81-930-25-4369  
<http://www.yaskawa.co.jp>

**YASKAWA ELECTRIC CORPORATION**

New Pier Takeshiba South Tower, 1-16-1, Kaigan, Minatoku, Tokyo, 105-6891, Japan  
Phone: 81-3-5402-4502 Fax: 81-3-5402-4580  
<http://www.yaskawa.co.jp>

**YASKAWA ELÉTRICO DO BRASIL LTDA.**

777, Avenida Piraporinha, Diadema, São Paulo, 09950-000, Brasil  
Phone: 55-11-3585-1100 Fax: 55-11-3585-1187  
<http://www.yaskawa.com.br>

**YASKAWA EUROPE GmbH**

185, Hauptstraße, Eschborn, 65760, Germany  
Phone: 49-6196-569-300 Fax: 49-6196-569-398  
<http://www.yaskawa.eu.com>

**YASKAWA ELECTRIC KOREA CORPORATION**

9F, Kyobo Securities Bldg., 26-4, Yeouido-dong, Yeongdeungpo-gu, Seoul, 150-737, Korea  
Phone: 82-2-784-7844 Fax: 82-2-784-8495  
<http://www.yaskawa.co.kr>

**YASKAWA ELECTRIC (SINGAPORE) PTE. LTD.**

151, Lorong Chuan, #04-02A, New Tech Park, 556741, Singapore  
Phone: 65-6282-3003 Fax: 65-6289-3003  
<http://www.yaskawa.com.sg>

**YASKAWA ELECTRIC (THAILAND) CO., LTD.**

252/125-126, 27th Floor, Muang Thai-Phatra Tower B, Rachadapisek Road, Huaykwang, Bangkok, 10310, Thailand  
Phone: 66-2693-2200 Fax: 66-2693-4200  
<http://www.yaskawa.co.th>

**YASKAWA ELECTRIC (CHINA) CO., LTD.**

22F, One Corporate Avenue, No.222, Hubin Road, Shanghai, 200021, China  
Phone: 86-21-5385-2200 Fax: 86-21-5385-3299  
<http://www.yaskawa.com.cn>

**YASKAWA ELECTRIC (CHINA) CO., LTD. BEIJING OFFICE**

Room 1011, Tower W3 Oriental Plaza, No. 1, East Chang An Ave.,  
Dong Cheng District, Beijing, 100738, China  
Phone: 86-10-8518-4086 Fax: 86-10-8518-4082

**YASKAWA ELECTRIC TAIWAN CORPORATION**

9F, 16, Nanking E. Rd., Sec. 3, Taipei, 104, Taiwan  
Phone: 886-2-2502-5003 Fax: 886-2-2505-1280

**YASKAWA INDIA PRIVATE LIMITED**

#17/A, Electronics City, Hosur Road, Bangalore, 560 100 (Karnataka), India  
Phone: 91-80-4244-1900 Fax: 91-80-4244-1901  
<http://www.yaskawaindia.in>

---

# YASKAWA

## YASKAWA AMERICA, INC.

In the event that the end user of this product is to be the military and said product is to be employed in any weapons systems or the manufacture thereof, the export will fall under the relevant regulations as stipulated in the Foreign Exchange and Foreign Trade Regulations. Therefore, be sure to follow all procedures and submit all relevant documentation according to any and all rules, regulations and laws that may apply.

Specifications are subject to change without notice for ongoing product modifications and improvements.

© 2014-2015 YASKAWA AMERICA, INC. All rights reserved.



MANUAL NO. TOEP YAIQPM 03B

Published in USA September 2015 14-12

