

Subject: SUMMARY: Conversion from Sigma to Sigma II

Product: SGDB and SGMS → SGDH and SGMSH

Introduction:

The Sigma servo line, including SGMS motors and SGDB amplifiers, was upgraded in 1998 with newer technology (Sigma II product line: SGMSH motors and SGDH amplifiers). Yaskawa will continue to make the original Sigma series products available, though delivery times may be longer than those for the Sigma II products. Some users will find it advantageous to upgrade to Sigma II products. This document will provide users of the original Sigma series with a summary guideline of requirements to upgrade to Sigma II technology^{1,2}.

Motor Replacement: SGMS to SGMSH

- **Part Number:** Sigma motor type SGMS can be directly replaced with Sigma II motor type SGMSH. The SGMSH motors have the same or better performance than the SGMS motors. *The original motor and drive must both be replaced when upgrading to Sigma II technology.*
- **Mounting:** All mounting dimensions of the SGMSH motor are the same as the SGMS motor. See Appendix A for a typical motor size comparison.

Amplifier Replacement: SGDB to SGDH

- **Part Number:** Sigma amplifier type SGDB can be directly replaced with Sigma II amplifier SGDH. *The original motor and drive must both be replaced when upgrading to Sigma II technology.*
- **Mounting:** The physical dimensions of the SGDH amplifiers are the same as the SGDB or smaller. Mounting hole locations are different for sizes SGDB-05 through SGDB-30. Mounting holes for SGDB-50 is exactly the same as its SGDB predecessors. Appendix A shows typical size and mounting differences.
- **Parameters:** The SGDB and SGDH have different parameter sets. SigmaWin Lite can be used to communicate to both amplifiers for parameter setting. Yaskawa provides a part number converter to help with parameter conversion.

Wiring

- **Motor Wiring:** The motor power cables that were used with the SGMS motors will also work with the SGMSH motors. For the encoder cable, Yaskawa highly recommends the purchase of new pre-wired cable for the upgrade installation. In most cases, it is more cost effective and less time consuming to run the new cables than to modify existing cables. While it is possible to re-wire with the existing cables in place, this will require soldering in the cabinet.
- **I/O Signal Wiring:** I/O wiring is almost identical between SGDB and SGDH. The monitor signals (now accessible through the CN5 connector) and the +12V / -12V signals are not available through the CN1 connector on the SGDH. See Appendix B.

¹ Sigma II motors and amplifiers provide high performance motion control in combination. Therefore, a SGMS (Sigma) motor cannot be used with a SGDH (Sigma II) amplifier, and a SGMSH (Sigma II) motor cannot be used with a SGDB (Sigma) amplifier. Replacement of the motor and amplifier must be made simultaneously.

² If the decision is made to upgrade, a detailed step-by-step planning guide is available.

Appendix A – Motor and Amplifier Dimensions

The following pages offer a reference for a typical size comparison between Sigma and Sigma II motors and amplifiers. If the Sigma II upgrade is desired, Yaskawa provides a detailed step-by-step worksheet as a planning guide.

This upgrade documentation is designed to upgrade standard equipment only. For motors with custom OEM modifications, reference document **Service Options for Customized Servos**, available on Yaskawa's FAQ site: <http://faq.yaskawa.com>. Custom motors and amps can be identified by a special code at the end of the part number (SGDB with **Y8** modification can be replaced with standard SGDH). The Part Number Converter that is offered as a companion to this document can be used to determine if a motor is custom.

Example Custom Motors

- SGMS-10AWAYR11
- SGMS-15A2A-MU21

Example Custom Amplifiers

- SGDB-10ADGY141
- SGDB-30EADGY224

Motor

The SGMSH series of motors have the same mounting dimensions and length as their SGMS predecessors. Therefore, upgrading to the Sigma II technology can be done with little difficulty. As noted in the summary, there are differences in the motor power and encoder connectors, so cables will need to be reworked or replaced.

In the interest of convenience, the following page shows a typical size comparison between SGMS and SGMSH motors. If the exact motor model is not shown and more detailed information is required, consult the Sigma II Product Catalog.

Amplifier

Mounting and overall dimensions of the SGDH amplifiers may vary from their SGDB predecessors. If the recommended amplifier spacing of 10 mm was maintained in the original panel design, the new SGDH amplifiers will fit into the same panel space, and in many cases (SGDH-44 and larger) into the same mounting holes. SGDH amplifiers that replace SGDB-30 and smaller will fit into the same overall panel space, but new mounting holes may be necessary.

The following pages (just after the motor comparison) show the typical size difference between SGDB and SGDH amplifiers. If your exact amplifier model is not shown and more detailed information is required, consult the Sigma II Product Catalog.

Reference:

Sigma II Product Catalog, document number **G-MI#99001E-Sigmall**

Sigma II User's Manual, document number **YEA-SIA-S800-32.2C**

These documents are available on the Yaskawa website at <http://www.yaskawa.com> on the Sigma II product page. They can also be ordered from Yaskawa by calling 1-800-YASKAWA or by e-mailing literature@yaskawa.com.

Yaskawa Electric America - 2121 Norman Drive South – Waukegan IL 60085
(800) YASKAWA - Fax (847) 887-7280

Sigma II 17-Bit Incremental or Absolute Encoder

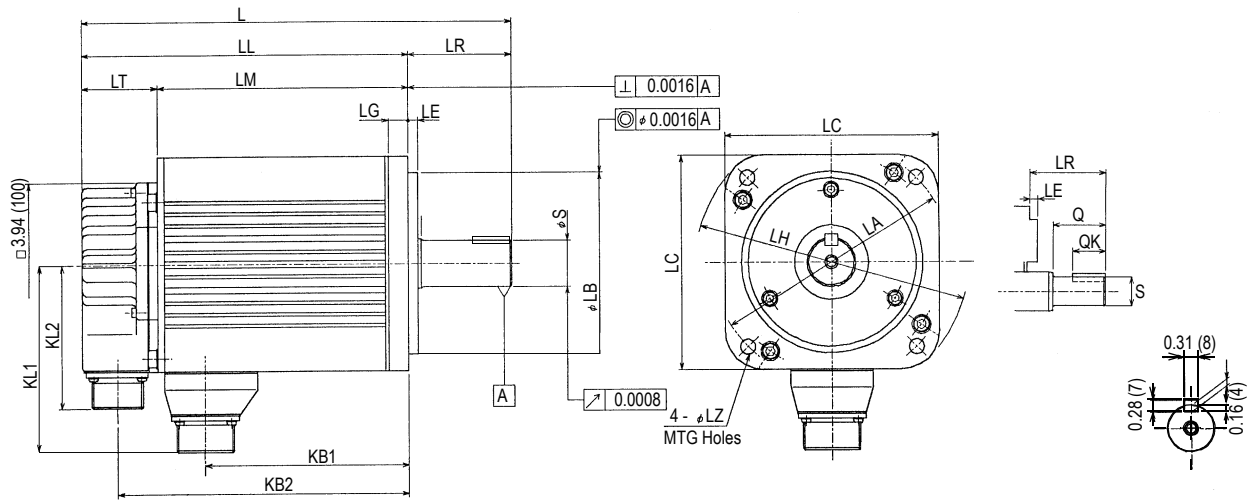

Type SGMSH-	L	LL	LM	LR	LT	KB1	KB2	KL1	KL2	Flange Dimensions								Shaft End Dimension			Approximate Mass lb _f (kg)	Allowable Radial Load lb _f (N)	Allowable Thrust Load lb _f (N)
										ΦLA	ΦLB	LC	LE	LG	ΦLH	ΦLZ	ΦS	Q	QK				
20A□A61	9.57 (243)	7.8 (198)	5.98 (152)	1.77 (45)	1.81 (46)	4.92 (125)	6.97 (177)	3.78 (96)	3.43 (87)	4.53 (115)	3.74 (95)	3.94 (100)	0.12 (3)	0.39 (10)	5.12 (130)	0.28 (7)	0.94 (24)	1.57 (40)	1.26 (32)	15.4 (7.0)	154 (686)	44 (196)	

Sigma I 4096 PPR Incremental Encoder

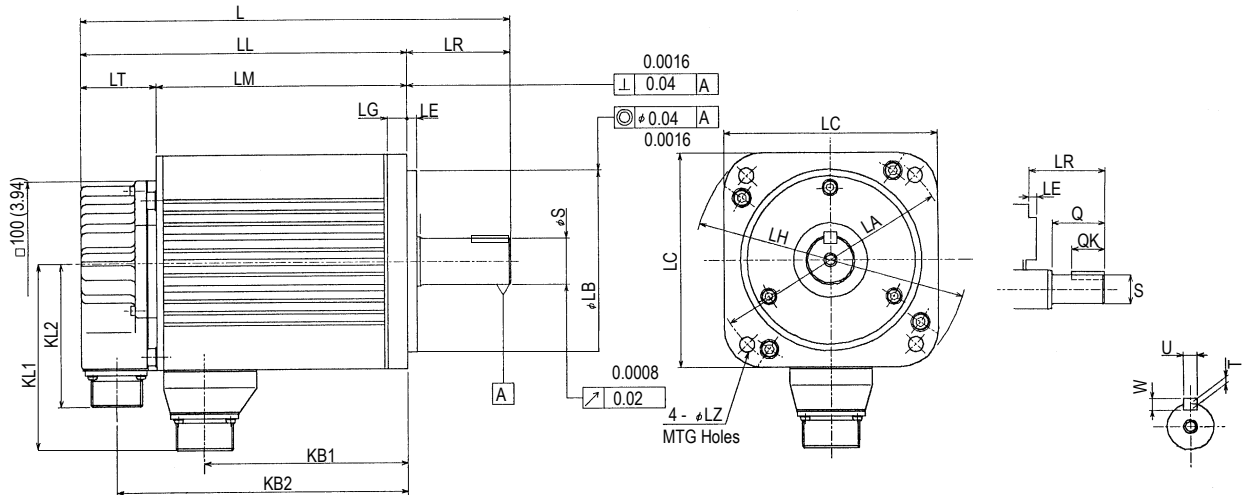

Type SGMS-	L	LL	LM	LR	LT	KB1	KB2	KL1	KL2	Flange Dimensions								Shaft End Dimension		Approx. Mass lb (kg)
										LA	LB	LC	LE	LG	LH	LJ	LZ	S	Q	
20A6AB	9.57 (243)	7.8 (198)	5.98 (152)	1.77 (45)	1.81 (46)	4.92 (125)	6.97 (177)	3.78 (96)	3.43 (87)	4.53 (115)	3.74 (95)	3.94 (100)	0.12 (3)	0.39 (10)	5.12 (130)	1.77 (45)	0.28 (7)	0.94 (24)	1.57 (40)	15.4 (7.0)

**Sigma II
ServoAmplifier
SGDH-05AE
SGDH-10AE**

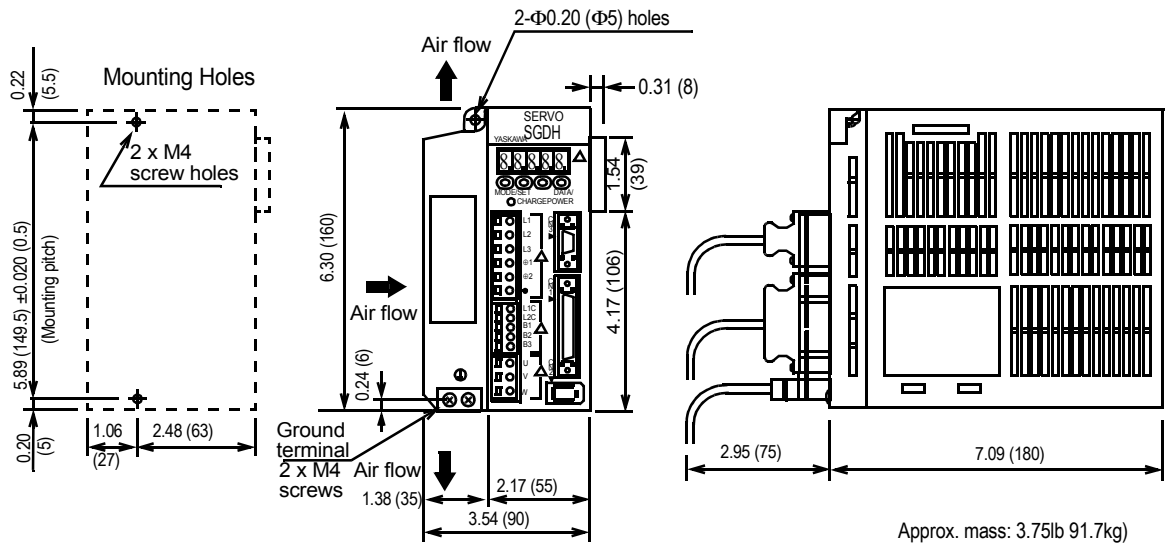

**Sigma I
ServoAmplifier
SGDB-05AD□
SGDB-10AD□**

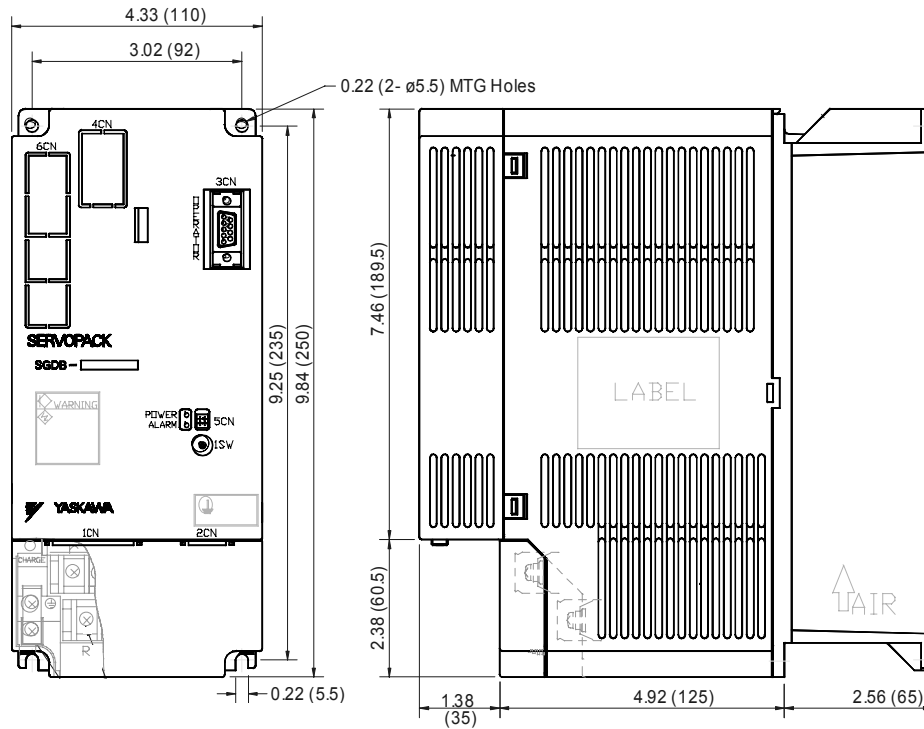

Appendix B – I/O interface wiring

The SGDH I/O wiring is generally the same as the SGDB. Only a few minor differences exist:

- The VTG-M and TRQ-M monitor signals in the SGDB do not exist in the SGDH. The same signals can be accessed through connector CN5.
- The +12V and –12V signals in the SGDB do not exist in the SGDH.
- Field Ground connection is made to the screw terminal on the amplifier instead of in the connector.

If the Sigma II upgrade is desired, Yaskawa can provide a detailed step-by-step worksheet as a planning guide.

Signal Name	Signal Description	SGDB Pin No.	SGDH Pin No.
SG	Signal ground (24V supply)	1	1
SG	Signal ground (SEN signal)	2	2
PL1	Pwr supply for open collector ref.	3	3
SEN	Sensor ON for abs. encoder	4	4
V-REF	Speed reference input	5	5
SG	Signal ground (V-REF)	6	6
PULS	Reference pulse input	7	7
*PULS	Reference pulse input (invert)	8	8
T-REF	Torque reference input	9	9
SG	Signal ground (T-REF)	10	10
SIGN	Reference sign input	11	11
*SIGN	Reference sign input (invert)	12	12
PL2	Pwr supply for open collector ref.	13	13
*CLR	Clear signal input (invert)	14	14
CLR	Clear signal	15	15
TRQ-M	Torque monitor	16	-
VTG-M	Speed monitor	17	-
PL3	Pwr supply for open collector ref.	18	18
PCO	Encoder output	19	19
*PCO	Encoder output	20	20
BAT	Abs. enc. battery input	21	21
BAT0	Abs. enc. battery input	22	22
+12V	Power supply for analog reference	23	-
-12V	Power supply for analog reference	24	-
/V-CMP+	Speed coincidence output	25	25
/V-CMP-	Speed coincidence output	26	26
/TGON+	Rotation detection output	27	27
/TGON-	Rotation detection output	28	28
/S-RDY+	Servo ready output	29	29
/S-RDY-	Servo ready output	30	30
ALM+	Alarm output	31	31
ALM-	Alarm output	32	32
PAO	Encoder output	33	33
*PAO	Encoder output	34	34
PBO	Encoder output	35	35
*PBO	Encoder output	36	36

ALO1	Alarm code output 1	37	37
ALO2	Alarm code output 2	38	38
ALO3	Alarm code input 3	39	39
/S-ON	Servo on	40	40
/P-CON	Proportional control reference	41	41
P-OT	Positive over-travel	42	42
N-OT	Negative over-travel	43	43
/ALMRST	Alarm reset	44	44
/P-CL	Positive current limit	45	45
/N-CL	Negative current limit	46	46
24V IN	24V external power supply input	47	47
PSO	'S' phase input (abs encoder)	48	48
*PSO	'S' phase input invert	49	49
FG	Frame Ground	50	Screw Terminal on Amp