

## Introduction

The remote digital operator kit allows a digital operator to be mounted up to 3 meters from the GPD315/V7. The kit includes:

1. One remote operator interface attachment
2. Two gaskets
3. One Digital Operator membrane cover
4. Four screws & nuts
5. Eight rubber washers
6. One operator interface
7. One meter (DS084) or three-meter (DS086) cable.

## Hardware Installation

### WARNING

**HAZARDOUS VOLTAGE CAN CAUSE SEVERE INJURY OR DEATH. LOCK ALL POWER SOURCES DRIVE IN “OFF” POSITION.**

1. Disconnect all electrical power to Drive.
2. Verify power has been disconnected by using a voltmeter to check for voltage at incoming power terminals (L1, L2, and L3).
3. Wait for the DC bus capacitors to completely discharge.
4. Remove contents from package. Verify that the above mentioned parts are included:
5. Remove existing Digital Operator from the drive. First, remove the screw on the front cover of the drive, and then pull off the bottom front cover. After this has been completed, remove the Digital Operator from the drive.
6. Replace the Digital Operator with the Digital Operator interface. Then re-attach the bottom front cover and tighten the screw down.
7. Insert the Digital Operator removed in step five into the operator carrier at a slant. See Figure 1. Insert the bottom first. Then, seat the top into the RJ-45 receptacle.

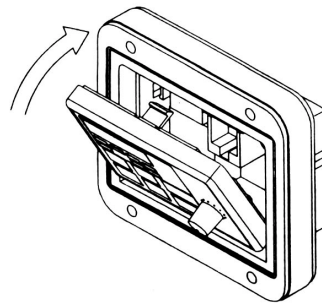

**Figure 1**

**Flush Mounting.** Mount the Digital Operator as follows.

1. Cut the Remote Operator mounting panel as shown in Fig. 1.1

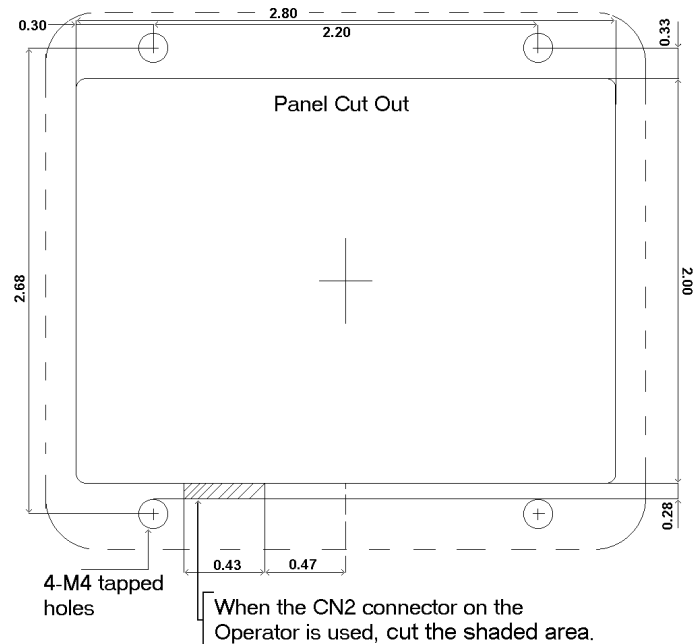

**Figure 1.1 (Dimensions in Inches, not actual size)**

2. Install the Remote Operator on the front side of the panel. Use four stainless screws and four rubber washers (one rubber washer per screw). See Figure 1.2

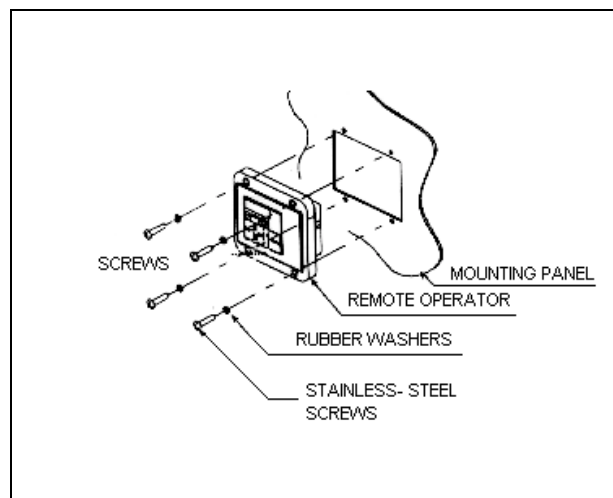

**FIGURE 1.2**

**Surface Mounting.** Mount the Digital Operator as follows.

1. Cut the Remote Operator mounting panel as shown in Fig. 2.1

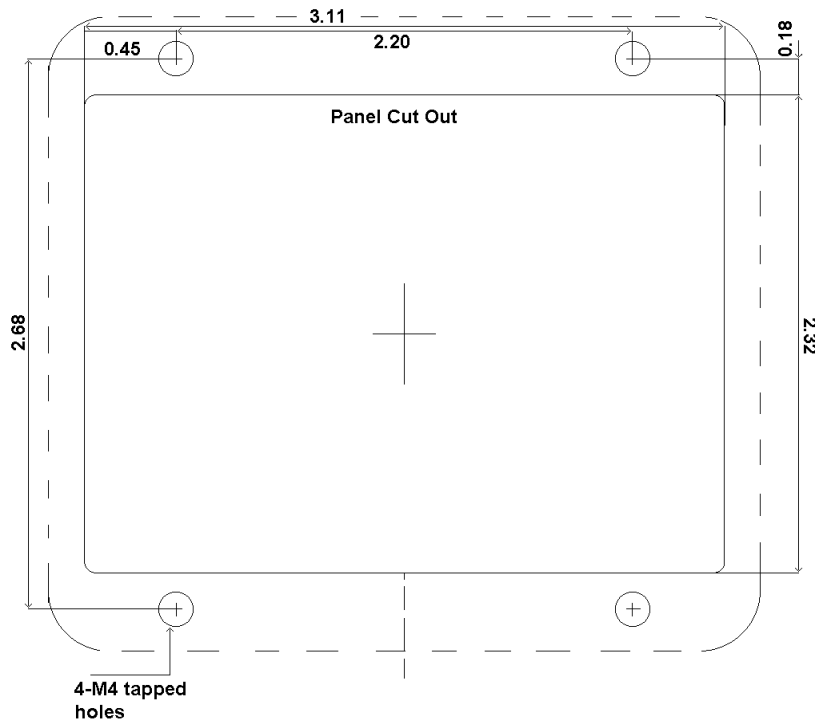

**Figure 2.1**  
(Dimensions in Inches, not actual size)

2. Apply the gasket to the front side of the digital operator. Install the remote operator from the rear side of panel. Insert the screws through the front side of the panel and then mount the washers and nuts to the rear side of the panel. Tighten screws gradually from the front side of panel. Refer to figure 2.2 for further installation directions.
3. Connect one end of the cable to the CN1 connector on the drive and the other end of the cable to the RJ-45 receptacle on the back of the Digital Operator.

**This completes the installation process.**

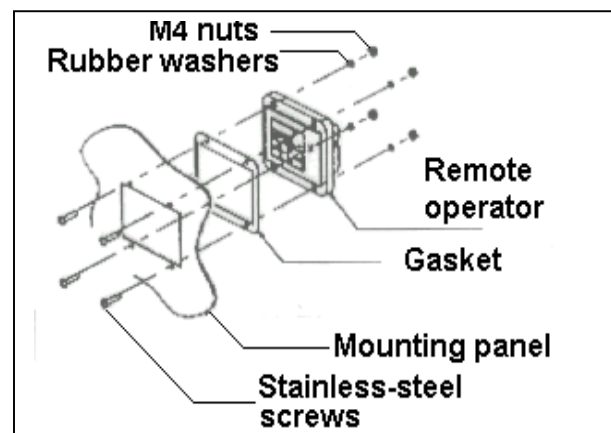

**Figure 2.1 Remote Operator Installation**