

DWG. NO. 900-090-845

All dimensions are in mm.

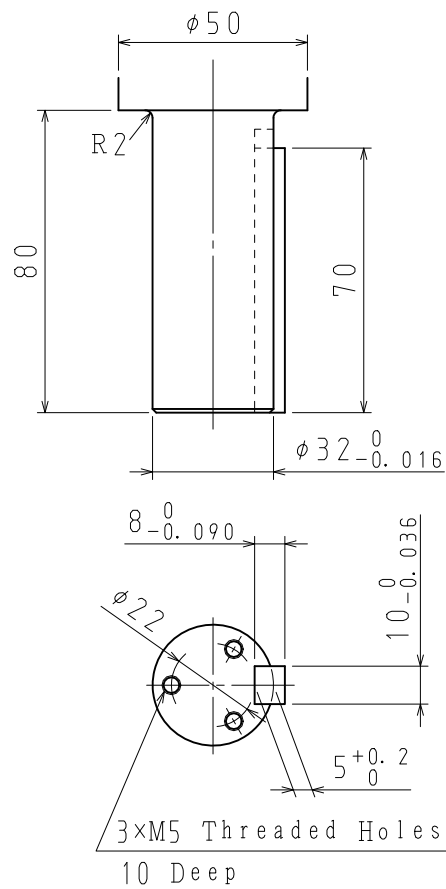

Detail of Shaft Extension

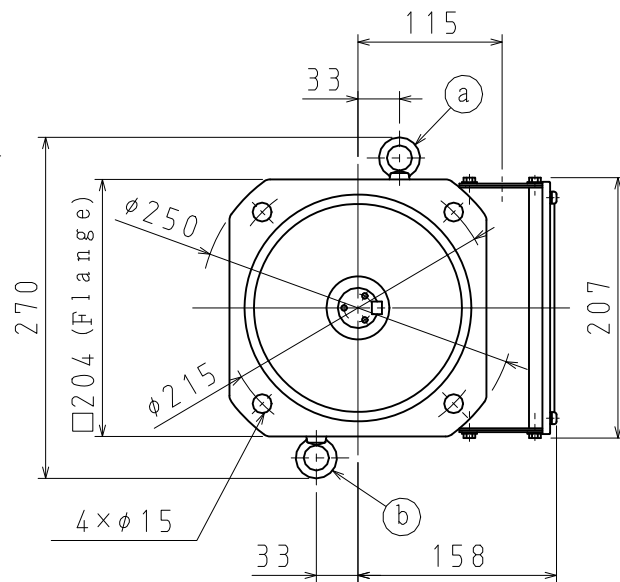
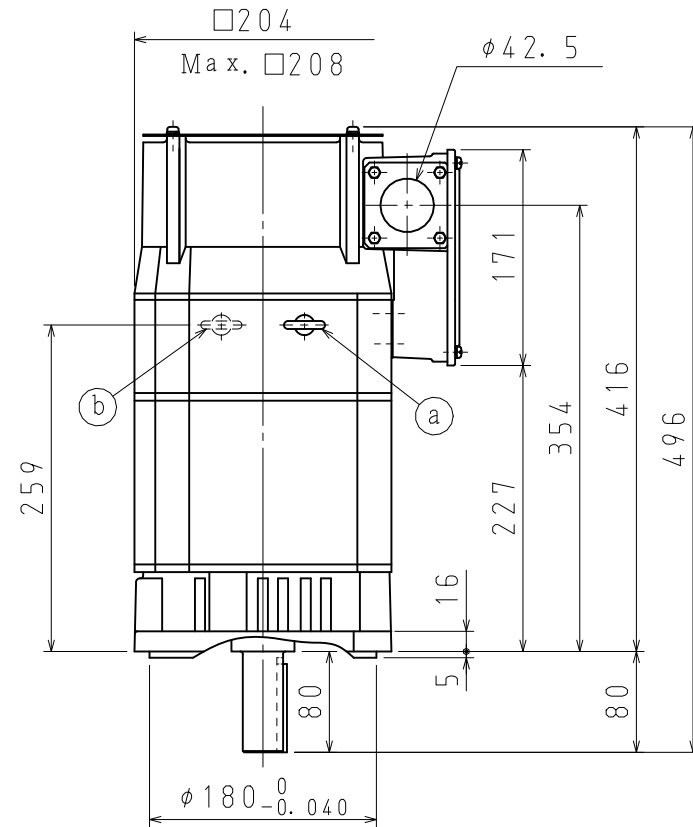

NOTES.

- Arrow (\triangle) indicates the direction of cooling air.
- Without OIL SEAL.

Customer	
Estimate No.	
Order No.	
Item No.	
Application	

Specification of Motor

Type	UAKAJ-08CZ1	Cooling Method	Externally Fan-cooled Type	
Voltage	200 V	Fan	Voltage 200/200 V	
Output	S3:50%ED	Frequency	50/60 Hz	
	S1:Cont.	Input	45/63 W	
Poles	4 P	Current	0.20/0.25 A	
Speed	Base	1500 min ⁻¹	Thermal Class	F
	Maximum	10000 min ⁻¹	Ambient Temperature	0~40℃
	Minimum	40 min ⁻¹	Vibration	V5 or Below
Inertia ($\frac{GD^2}{4}$)	0.021 kg·m ²	Noise	75dB (A) or Below	
Over Load Capacity	Refer to the graph at the bottom.	Approx. Mass	52kg	
		Painting	Munsell Notation N1.5	
Allowable Radial Load	1470N at the shaft end	Inverter Type	Σ-V-SD, CACR-JU036A2A	
Protective Enclosure	IP44	Inverter Output	7.5/5.5 kW	
Vibration Resistance	24.5m/sec ² or Below	Series	Standard	
Characteristics Tolerances (T. I. R)	Maximum Face Runout	0.04	Encoder Type	UTMSI-10AAGAZA
	Maximum Permissible Eccentricity of Mounting Rabbet	0.04	Dimensions of terminal box	900-111-516
	Shaft Runout at the End	0.02		

Output-Speed Characteristics

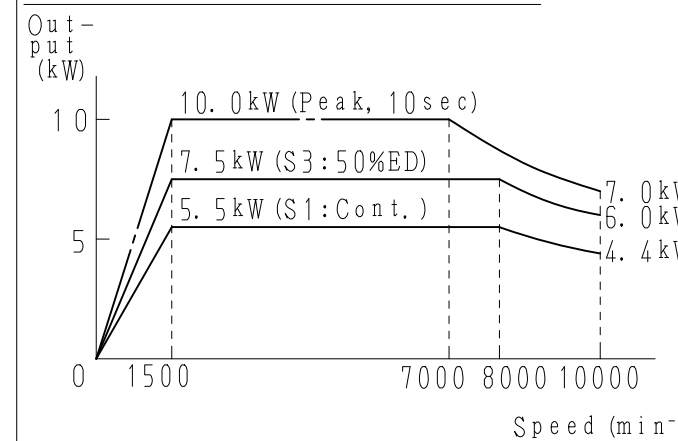

Torque-Speed Characteristics

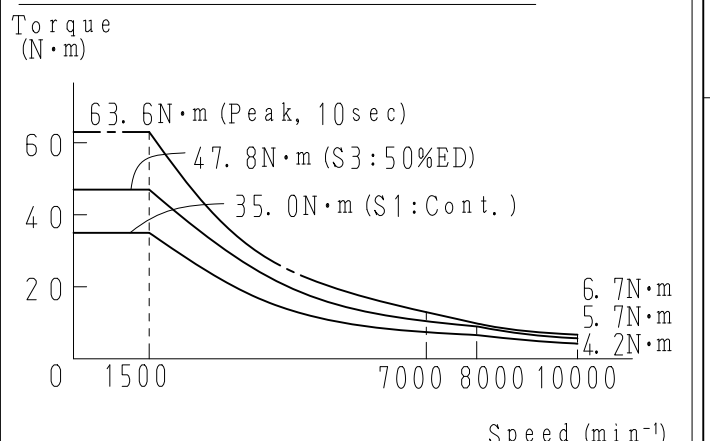

Remarks

•Peak power is the reference characteristic to calculate acceleration time, not guaranteed characteristic.

Feb. 15, '12 K. Maruyama/M. Matsunoto

YASKAWA
株式会社 安川電機

SCALE 1:6
DRAW. K. Maruyama
CHECK H. Shimono
APPR. M. Matsunoto

TITLE Dimensions of AC Spindle motor

DATE Dec. 08, '10
DWG. NO. **900-090-845**
REV. 2