

DWG. NO. 900-098-868

Customer	
Estimate No.	
Order No.	
Item No.	
Application	

All dimensions are in mm.

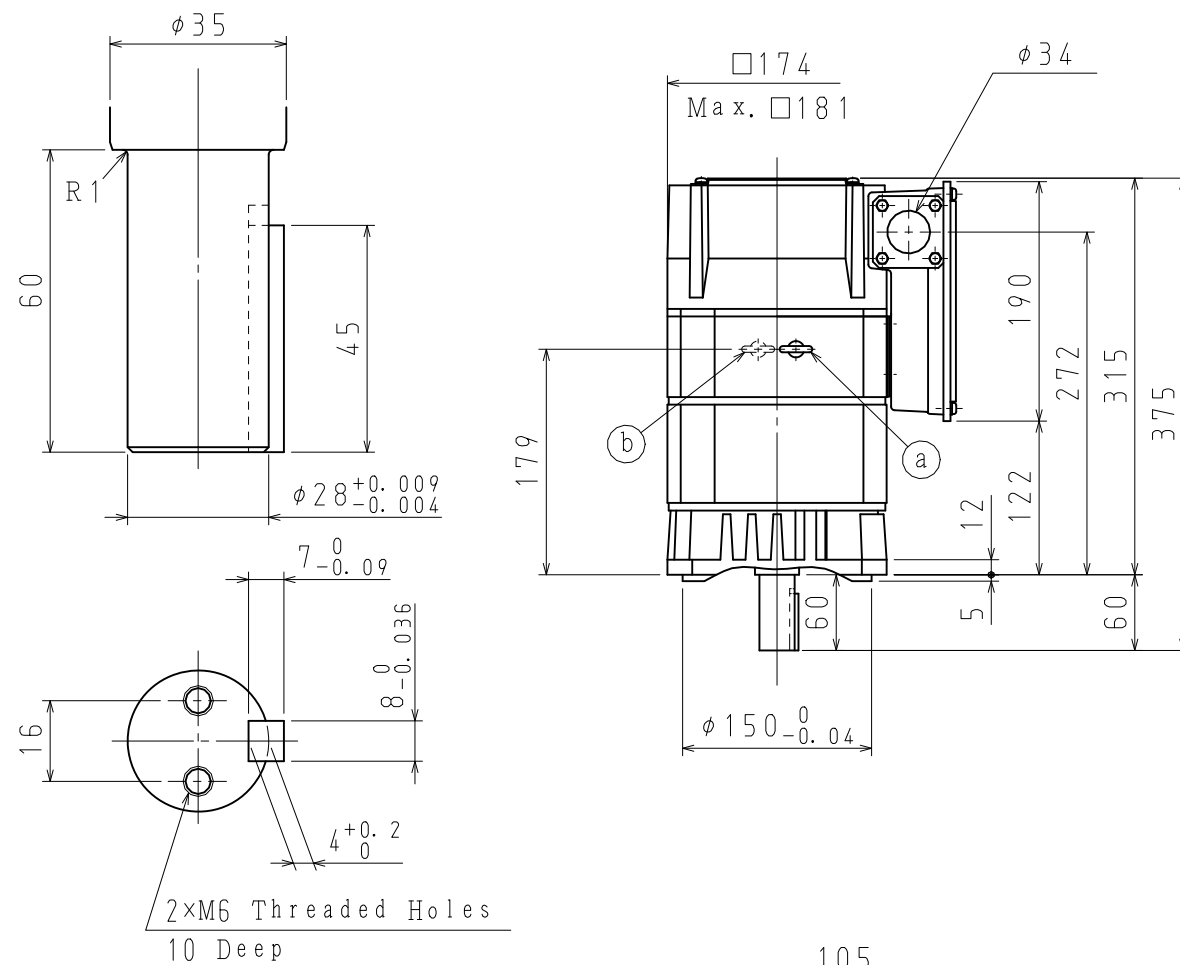

Detail of Shaft Extension

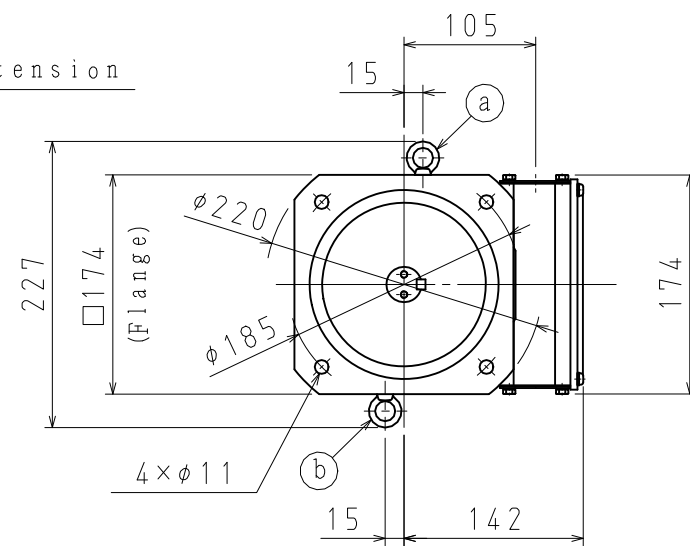

NOTES.

1. Arrow () indicates the direction of cooling air.
2. Without OIL SEAL.

Specification of Motor

Type	UAKAJ-04CZ1	Cooling Method	Externally Fan-cooled Type	
Voltage	200 V	Fan	Voltage 200/200 V	
Output	S3:50%ED 3.7 kW	Frequency	50/60 Hz	
	S1:Cont. 2.2 kW	Input	32/34 W	
Poles	4 P	Current	0.09/0.09 A	
Speed	Base 1500 min <sup>-1</sup>	Thermal Class	F	
	Maximum 10000 min <sup>-1</sup>	Ambient Temperature	0~40℃	
	Minimum 40 min <sup>-1</sup>	Vibration	V5 or Below	
Inertia ( $\frac{GD^2}{4}$ )	0.0071 kg·m <sup>2</sup>	Noise	75dB (A) or Below	
Over Load Capacity	Refer to the graph at the bottom.	Approx. Mass	30kg	
Allowable Radial Load	1180N at the shaft end	Painting	Munsell Notation N1.5	
Protective Enclosure	IP44	Inverter Type	Σ-V-SD, CACR-JU028A2A	
Vibration Resistance	24.5m/sec <sup>2</sup> or Below	Output	5.5/3.7 kW	
Characteristics Tolerances (T. I. R)	Maximum Face Runout	0.04	Series	Standard
	Maximum Permissible Eccentricity of Mounting Rabbet	0.04	Encoder Type	UTMSI-10AAGAZA
	Shaft Runout at the End	0.02	Dimensions of terminal box	900-111-513

Output-Speed Characteristics

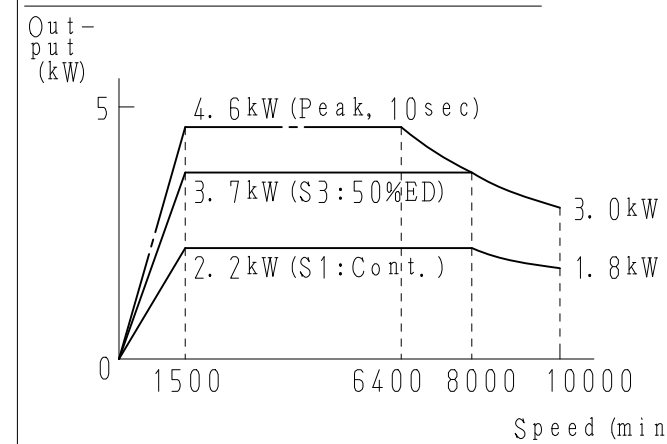

Torque-Speed Characteristics

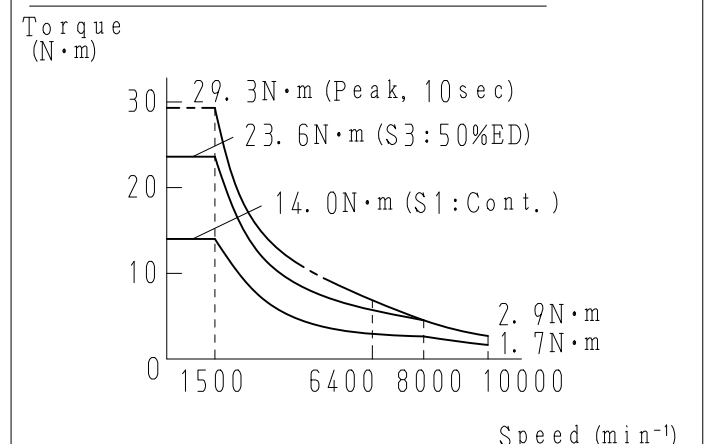

Remarks

- Peak power is the reference characteristic to calculate acceleration time, not guaranteed characteristic.

<p>株式会社 安川電機</p>	<p>SCALE 1 : 6</p>	<p>DRAW. K. Maruyama</p> <p>CHECK H. Shimono</p> <p>APPR. M. Matsunoto</p>	<p>TITLE Dimensions of AC Spindle motor</p>	<p>DATE Jun. 08, '11</p>	<p>REV. 1</p>
		<p>DWG. NO. 900-098-868</p>			<p>SIZE A3</p>