

TERMINAL AND WIRING DETAILS (SCALE 1:6)

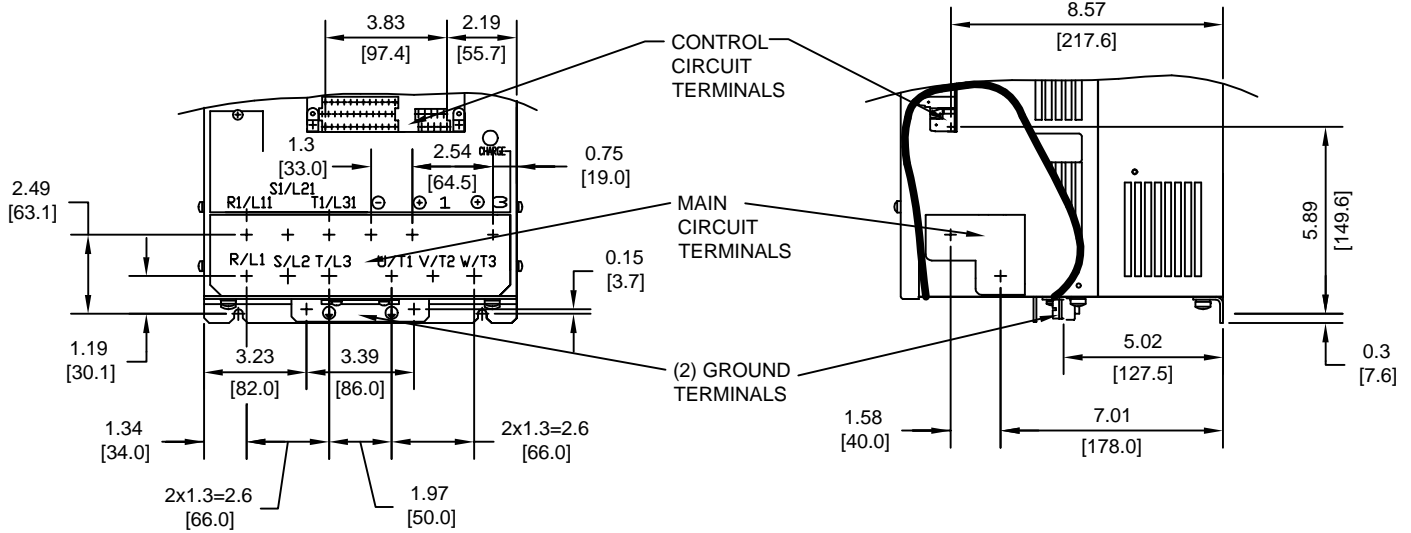

TERMINAL AND WIRE SPECIFICATIONS FOR MAIN CIRCUIT AND GROUND

MODEL # CIMR-G7U	TERMINAL SYMBOL	TERMINAL SCREW	CLAMPING TORQUE lb.in.(N.m.)	WIRE RANGE AWG(mm ²)
2018	R/L1, S/L2, T/L3, ⊕, ⊕1, R1/L11, S1/L21, T1/L31, U/T1, V/T2, W/T3	M8	79.2 TO 88.0 (9.0 TO 10.0)	8-1/0 (8-60)
	⊕3	M6	35.2 TO 44.0 (4.0 TO 5.0)	8-4 (8-22)
	⊕	M8	79.2 TO 88.0 (9.0 TO 10.0)	SEE NOTE

NOTE: REFER TO APPLICABLE CODES FOR PROPER WIRE TYPE AND SIZE

MINIMUM INSTALLATION CLEARANCES (SCALE 1:10)

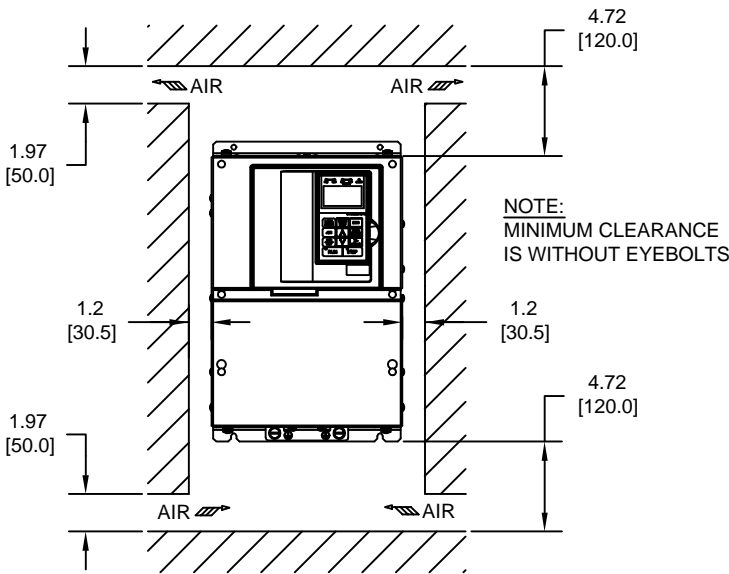

PANEL CUTOUT FOR EXTERNAL HEATSINK MOUNTING CONFIGURATION (SCALE 1:8)

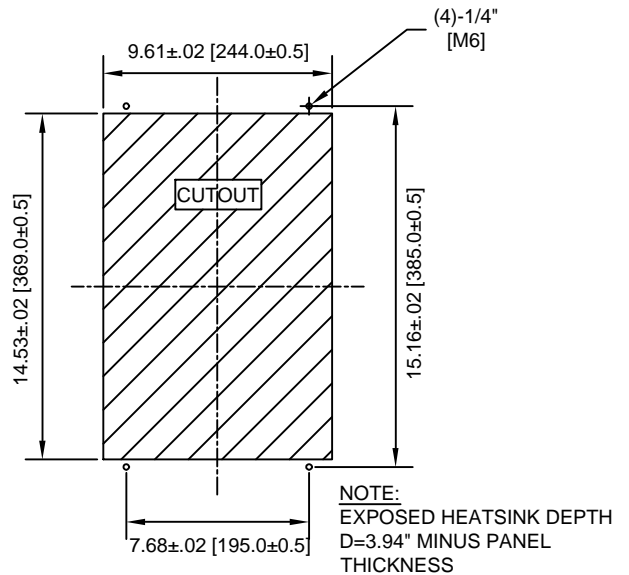

FOR ADDITIONAL DETAILS AND SPECIFICATIONS, CONSULT MANUAL

TOLERANCES/REFERENCES: - - - - -	<p>YASKAWA A World of Automation Solutions™</p> <p>YASKAWA ELECTRIC AMERICA, INC. Corporate Headquarters 2121 Norman Drive South Waukegan, IL 60085 1-800-YASKAWA http://www.yaskawa.com</p>	DRAWN: J. MATTAS DATE: 2-12-04	TITLE: G7 DIMENSION DRAWING FRAME SIZE 5 IP00 ENCLOSURE G7U2018			
		CHECKED: E. KU DATE: 4-4-04	TECH: J. CAIRO DATE: 3-30-04	SIZE A	REVISION -	PAGE 2 of 2
		APPROVED: T. SASADA DATE: 4-7-04	ORIGINAL DESIGN: -	DATE: -	DRAWING #: DD.G7.FR5.IP00.01	
		UNITS: IN[mm]	SCALE: BY VIEW			