

(4) Mounting Holes for M8 [5/16"] Screws. See Detail A for top mounting hole dimensions.

Note: Spreader bar required to avoid damage during lifting

(4)-Lifting Holes Ø20 [Ø0.79]

Nameplate

Center of Gravity
Note: Dimensions shown are measured from the bottom left mounting hole

Cooling fan location

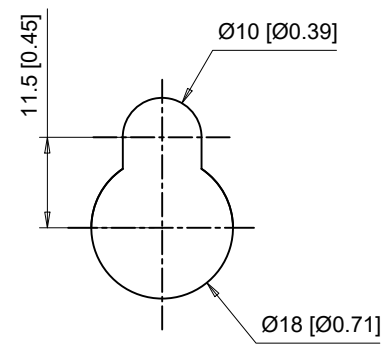
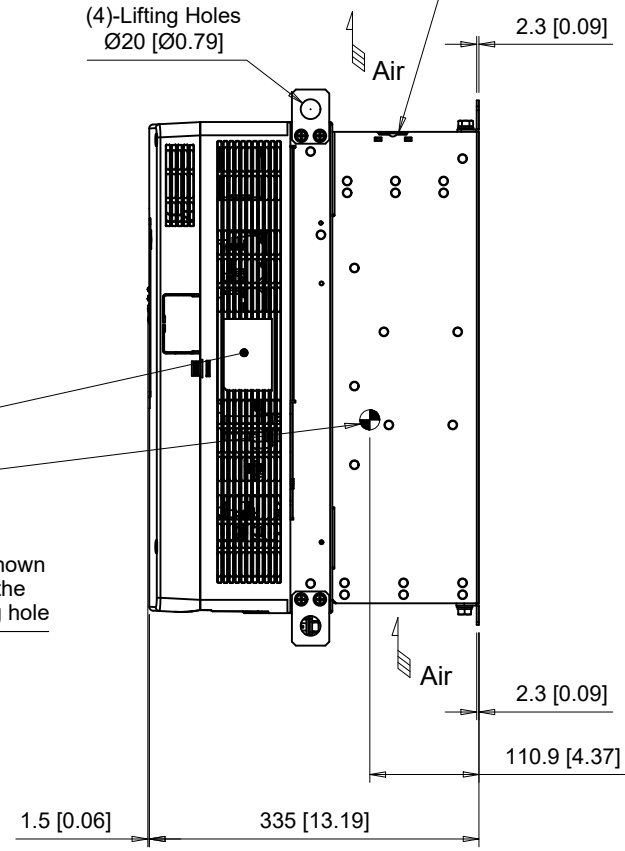

Detail A
Top mounting hole dimensions
Scale 1:1

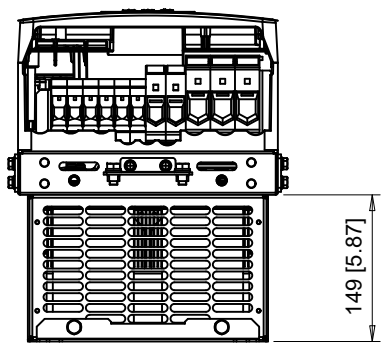

C/C:	INPUT VOLTAGE	WEIGHT	COOLING
GA80□	3-PHASE (VAC)	Kg (lb)	FANS
T140□□□	380 TO 480	31 (68.2)	2
T168□□□		31 (68.2)	2

□ denotes A-Z

YASKAWA

UNITS MM [IN]
SCALE 1:8

DRWN. J. MATTAS 12-9-19
CHKD. J. PIOTROWSKI 1-17-20
TECH. L. UDDIN 1-24-20
APRV. J. CAIRO 2-25-20

TITLE
GA800 12 PULSE DIMENSION DRAWING
FRAME SIZE 7
IP00 ENCLOSURE

SIZE A PAGE 1 OF 3
DWG.NO. DD.GA80.FR7.IP00.12P

REV 0

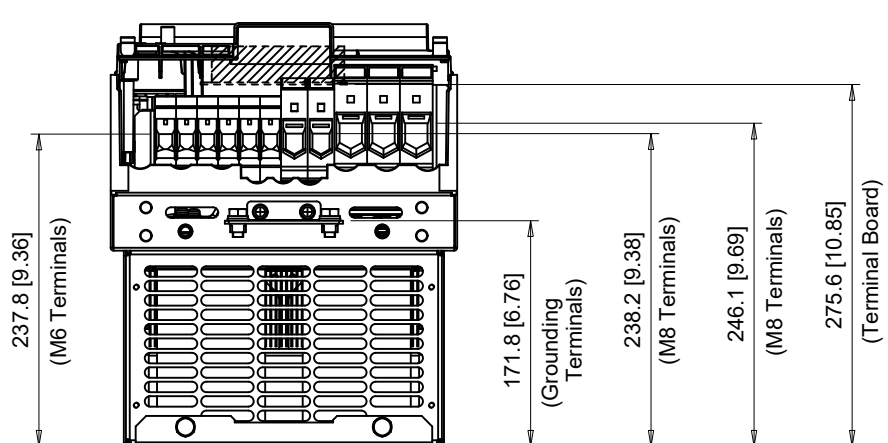
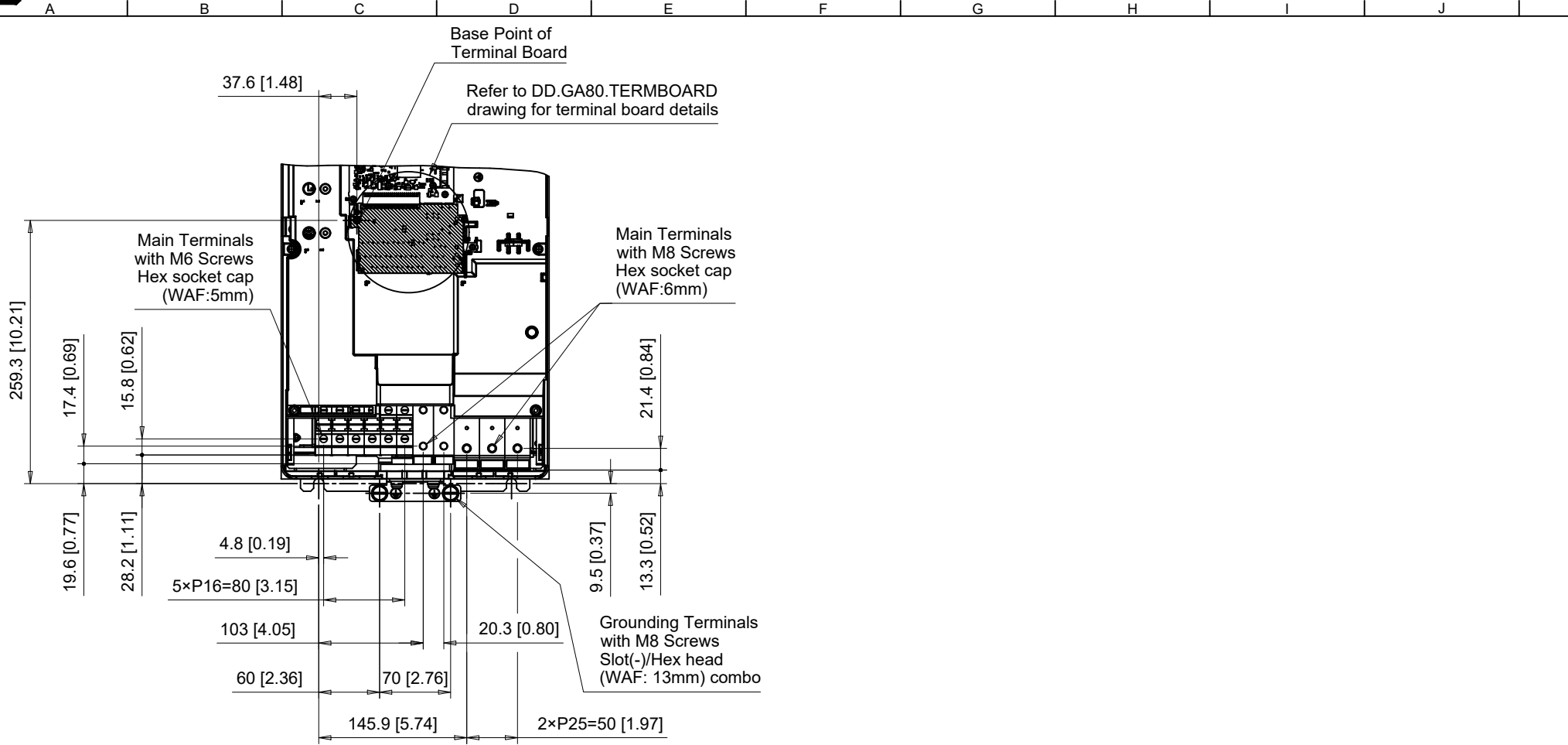

C/C: GA80□	TERMINAL SYMBOL	WIRE RANGE AWG (mm ²)	TERMINAL SCREW	CLAMPING TORQUE N.m. (lb.in.)
T140□□□ T168□□□	R/L1, S/L2, T/L3	14 - 1/0 (2.5 - 50)	M6	3.2 - 3.7 (28 - 33)
	R1/L11, S1/L21, T1/L31	14 - 1/0 (2.5 - 50)	M6	3.2 - 3.7 (28 - 33)
	U, V, W	2 - 4/0 (35 - 120)	M8	15 - 20 (135 - 175)
	-, +3	6 - 3/0 (16 - 95)	M8	15 - 20 (135 - 175)
	⊕	4 - 1/0 (25 - 50)	M8	9 - 11 (80 - 97)

□ Denotes A-Z
Note: Refer to applicable codes and standards for proper wire type and size.

YASKAWA

UNITS MM [IN]
SCALE 1:6

DRWN. J. MATTAS 12-9-19
CHKD. J. PIOTROWSKI 1-17-20
TECH. L. UDDIN 1-24-20
APRV. J. CAIRO 2-25-20

TITLE
GA800 12 PULSE DIMENSION DRAWING
FRAME SIZE 7
IP00 ENCLOSURE

SIZE A PAGE 2 OF 3
DWG.NO. DD.GA80.FR7.IP00.12P

REV 0

Minimum Installation Clearances

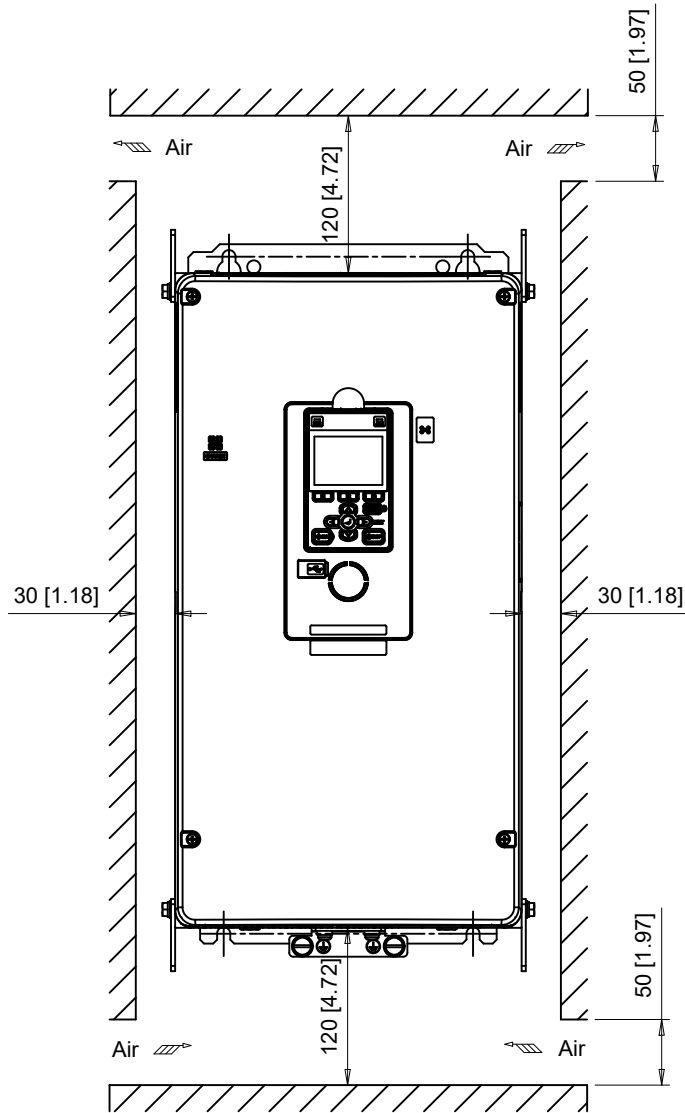

Note:
For alternate mounting configurations, consult manual.

Panel Cutout
For External Heatsink Mounting Configuration

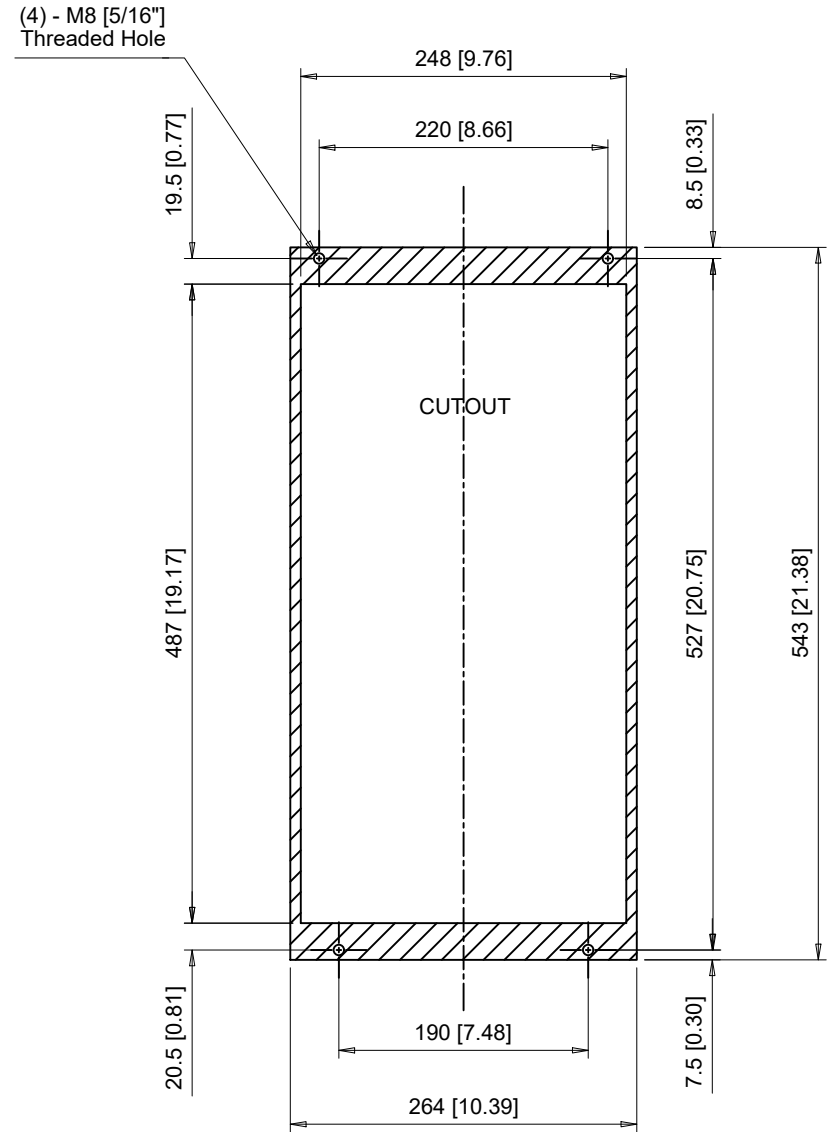

Notes:
Exposed heatsink minimum clearance D = 154 [6.06].
Refer to external heatsink instructions document for additional details.

YASKAWA

UNITS MM [IN]
SCALE 1:6

DRWN. J. MATTAS 12-9-19
CHKD. J. PIOTROWSKI 1-17-20
TECH. L. UDDIN 1-24-20
APRV. J. CAIRO 2-25-20

TITLE
GA800 12 PULSE DIMENSION DRAWING
FRAME SIZE 7
IP00 ENCLOSURE

SIZE A PAGE 3 OF 3
DWG.NO.
DD.GA80.FR7.IP00.12P

REV
0