

DWG. NO. EZZ901659-1/1

Model No.	Max Appli. Motor (kW)		Terminal Symbol			Cooling Fan	Mass (kg)			
	Normal Duty	Heavy Duty	INPUT OUTPUT(MOTOR)							
CIMR-J#2□0012B	3.0	2.2	R/L1	S/L2	T/L3	U/T1	V/T2	W/T3	1	1.7

#: A to Z
□: A to Z

Third Angle Projection
Dimensions in mm

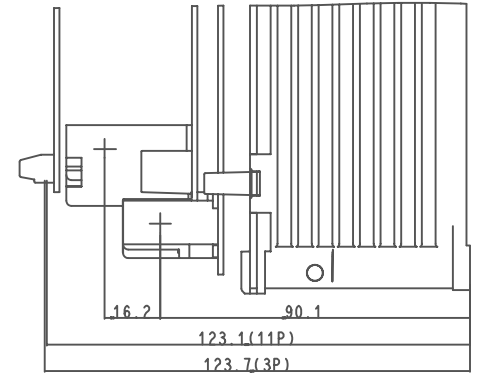
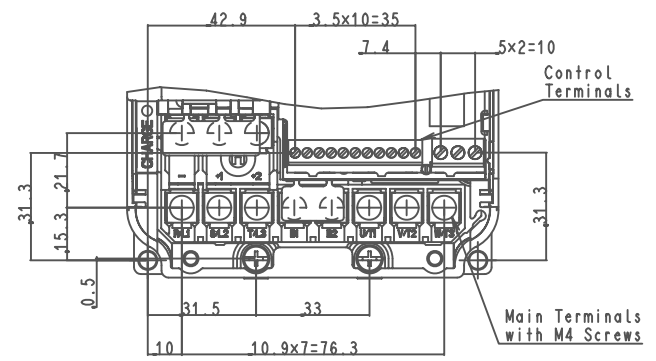
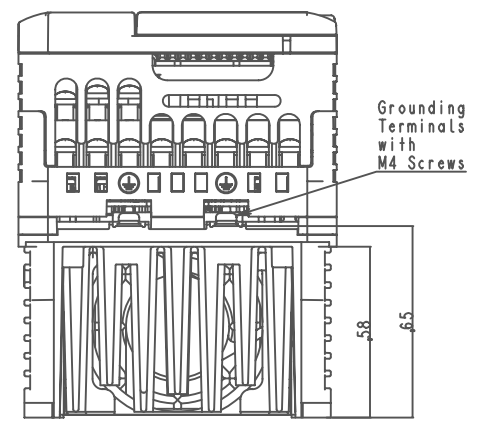
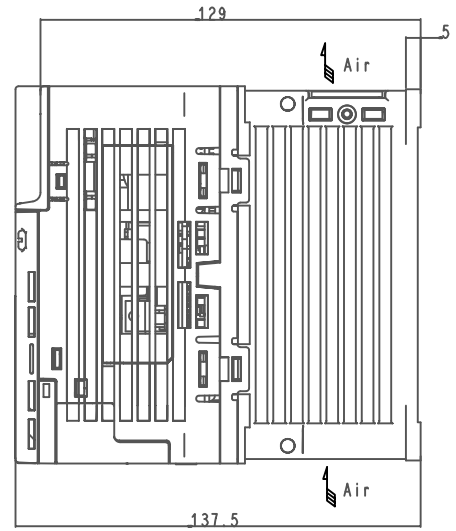
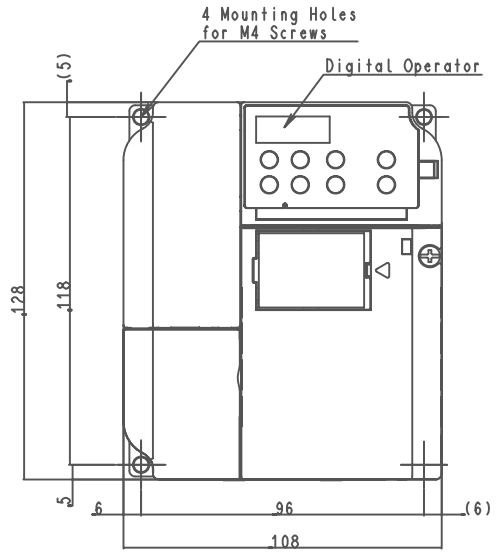

Detail (without Front cover) SCALE 0.7:1

REVISIONS

SCALE 0.6: 1



DRAW.	Oct.17,2007	N.Koga
CHECK	Oct.17,2007	T.Morihara
APPR.	Oct.17,2007	M.Kojyo

TITLE J1000 IP20 TYPE
DIMENSION DIAGRAM

DWG. NO. EZZ901659

REV. 1