

MODEL #	INPUT VOLTAGE (KV)	VOLTAGE CLASS (KV) (MOTOR)	DRIVE CURRENT RATING (A)	RATED POWER (HP)	HEAT DISSIPATION (kW)	TOTAL WEIGHT (lbs)[Kg]*	WIDTH (Inches [mm])	DEPTH (Inches [mm])	HEIGHT (Inches [mm])
MV2UA6AA052E1ABB	2.4	2.4	52	200	4.5	EST. 6040 [2740]	91.0 [2312]	41.5 [1055]	109.3 [2776]
MV2UA6AA068E1ABB			68	300	6.7				
MV2UA6AA080E1ABB			80	350	7.8				
MV2UA6AA093E1ABB			93	400	8.9				
MV2UA6AA102E1ABB			102	450	10.1				
MV2UD6DA039E1ABB	4.16	4.16	39	300	6.7	EST. 6040 [2740]	91.0 [2312]	41.5 [1055]	109.3 [2776]
MV2UD6DA052E1ABB			52	400	8.9				
MV2UD6DA058E1ABB			58	450	10.1				
MV2UD6DA064E1ABB			64	500	11.2				
MV2UD6DA077E1ABB			77	600	13.4				
MV2UD6DA093E1ABB	93	700	15.7	EST. 7000 [3175]					
MV2UD6DA102E1ABB	102	800	17.9						

* DOES NOT INCLUDE SHIPPING CONTAINER

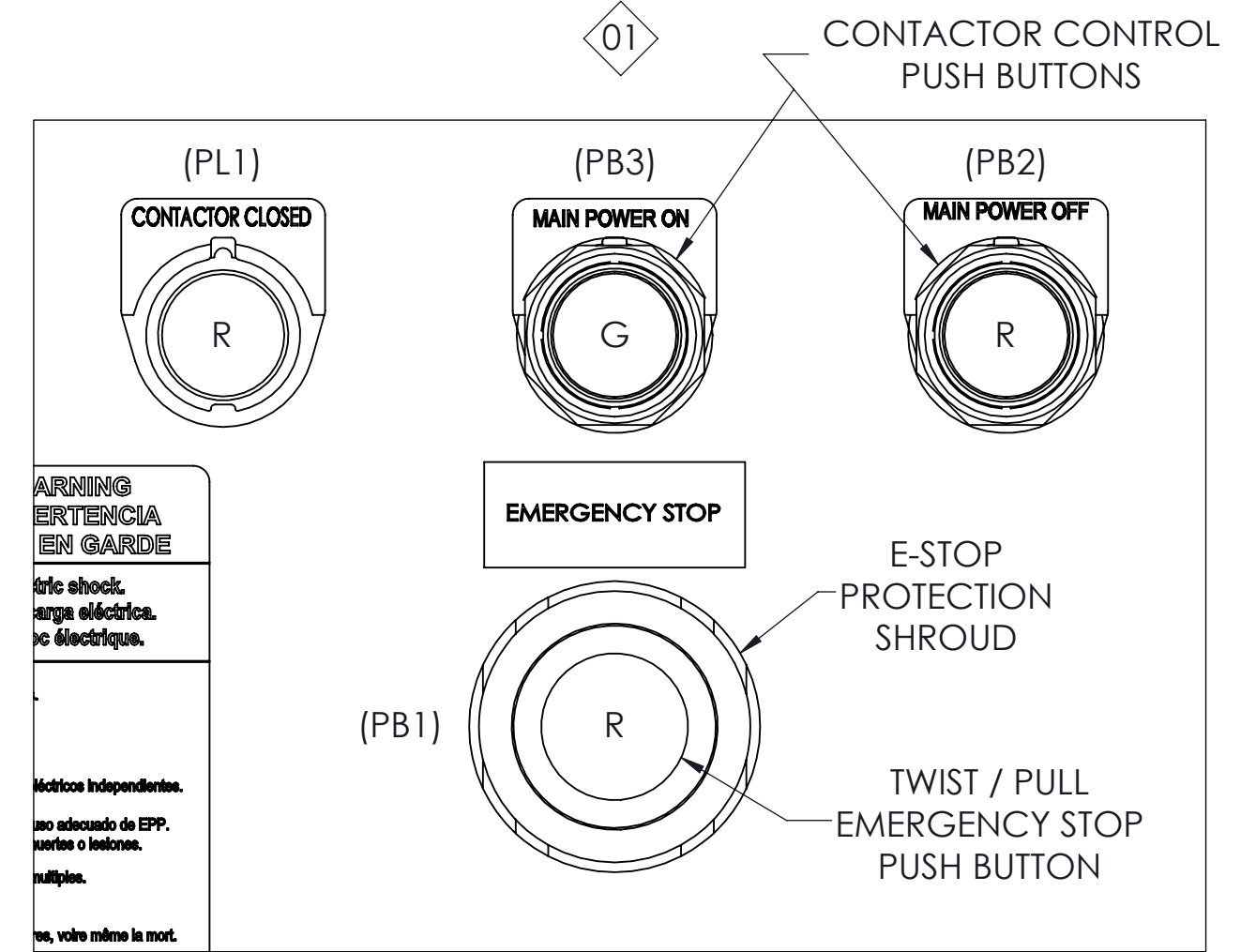
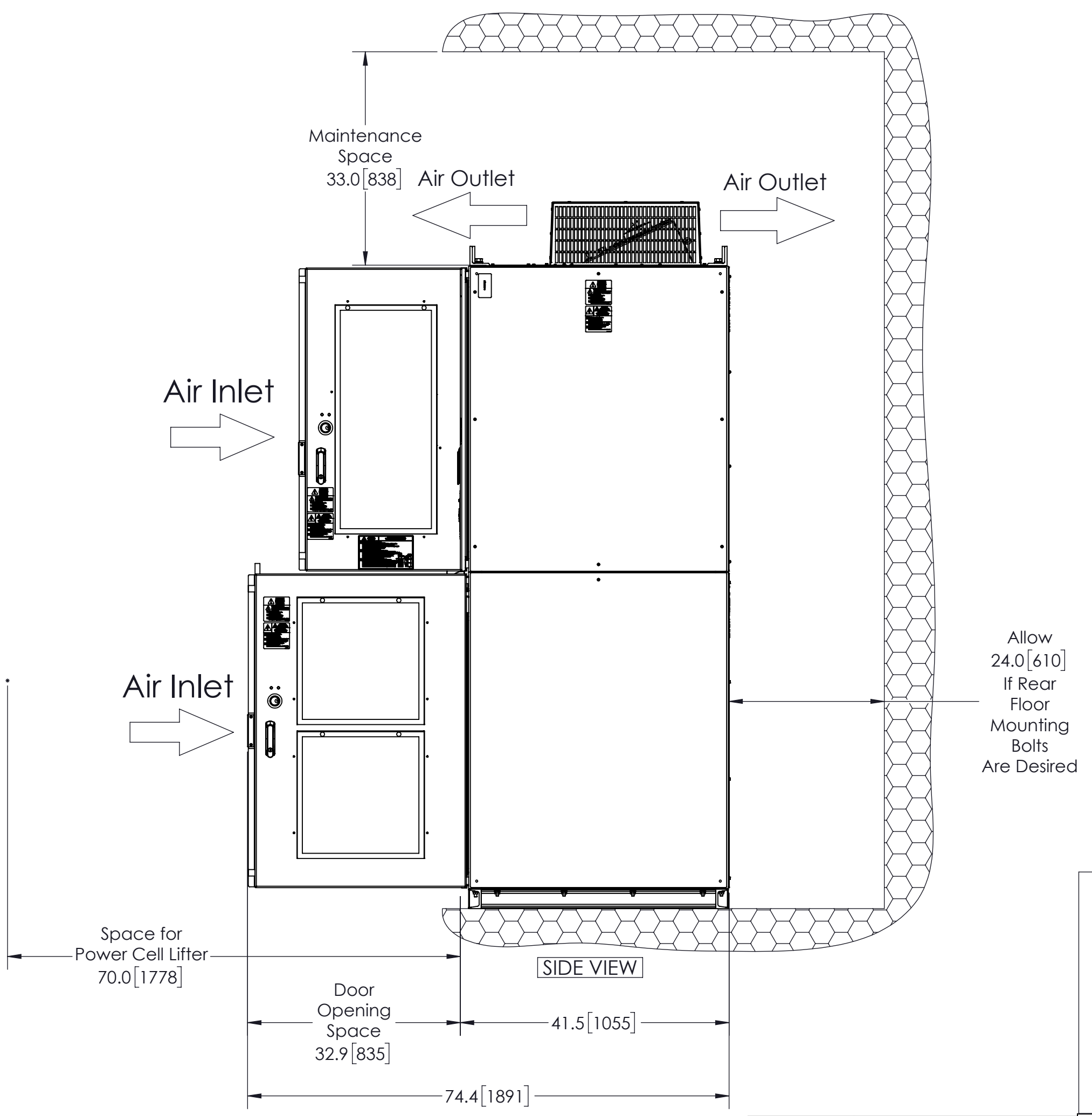
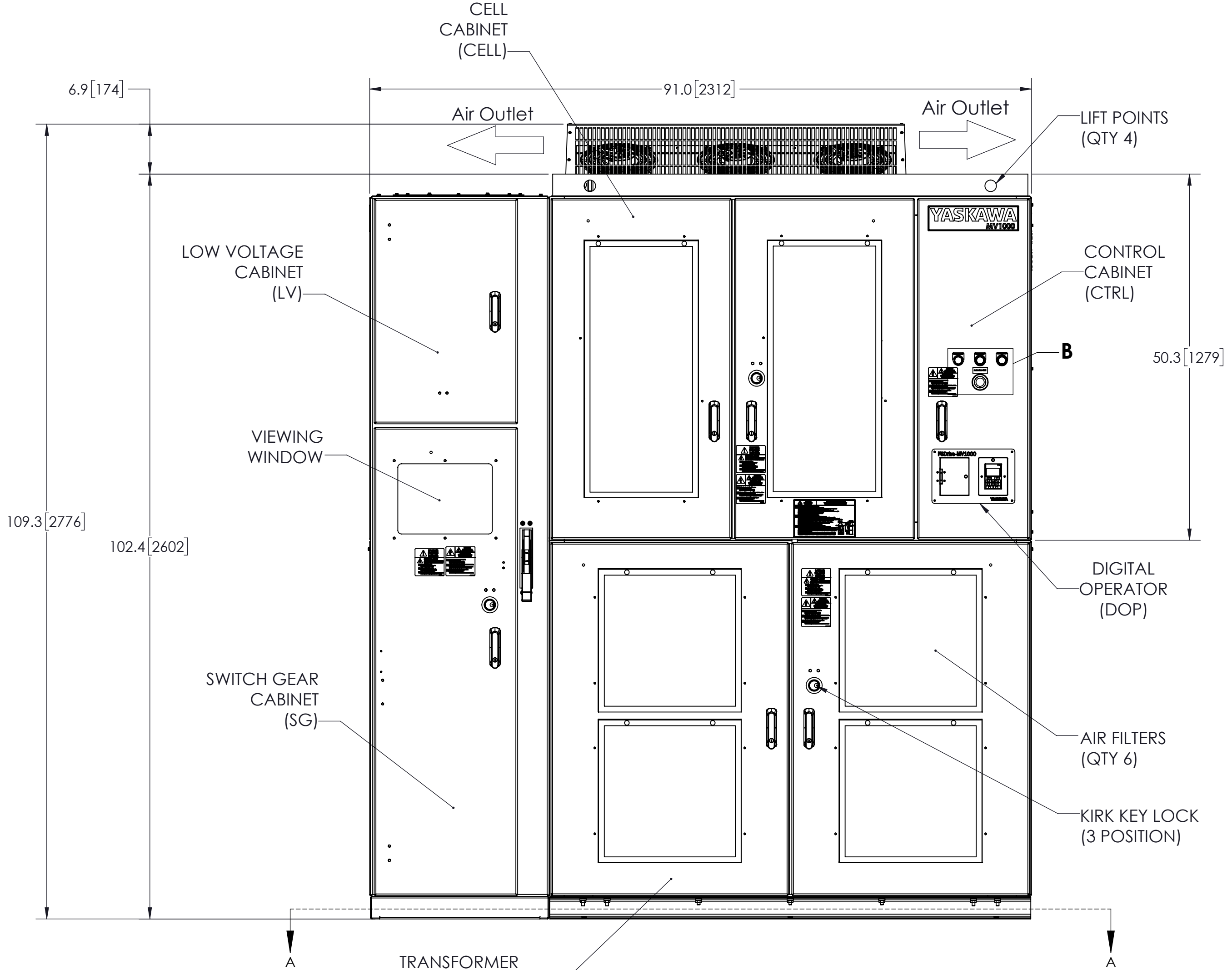
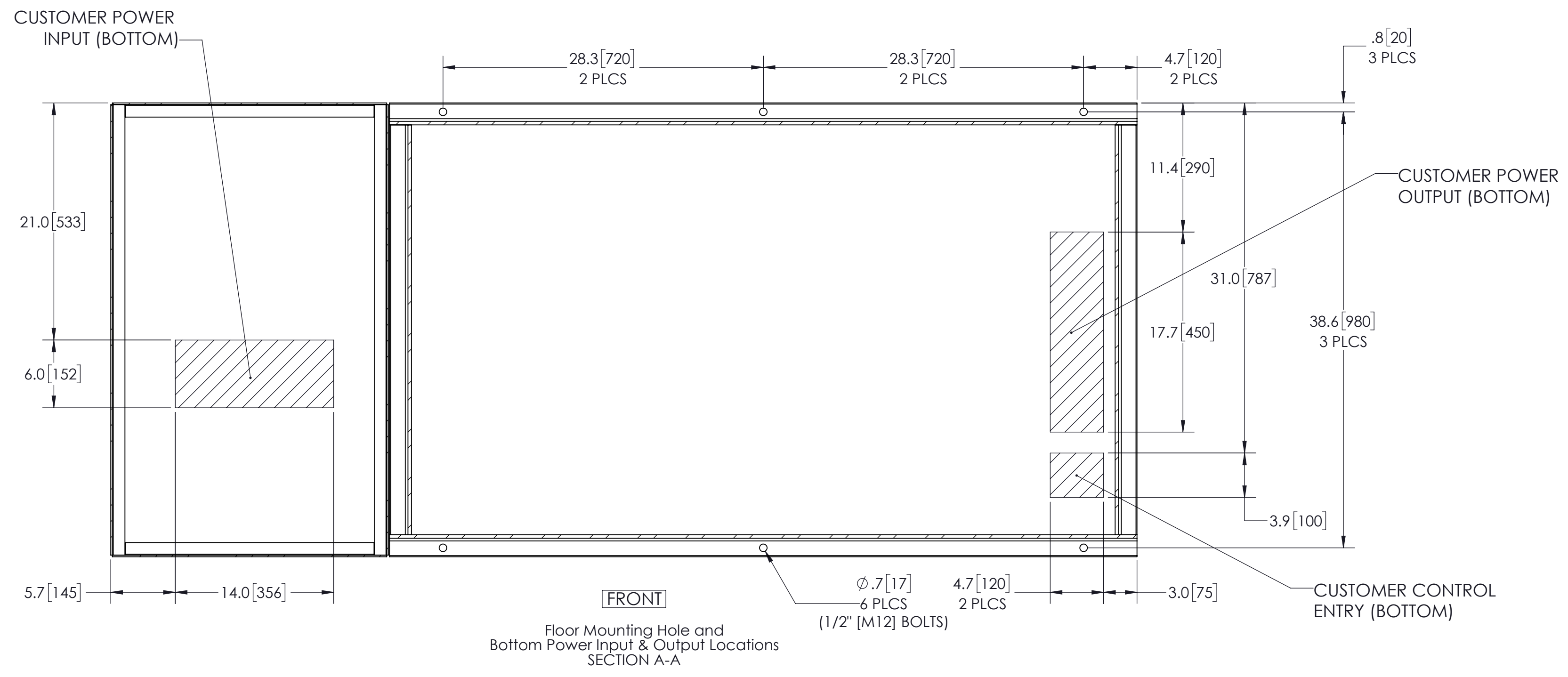
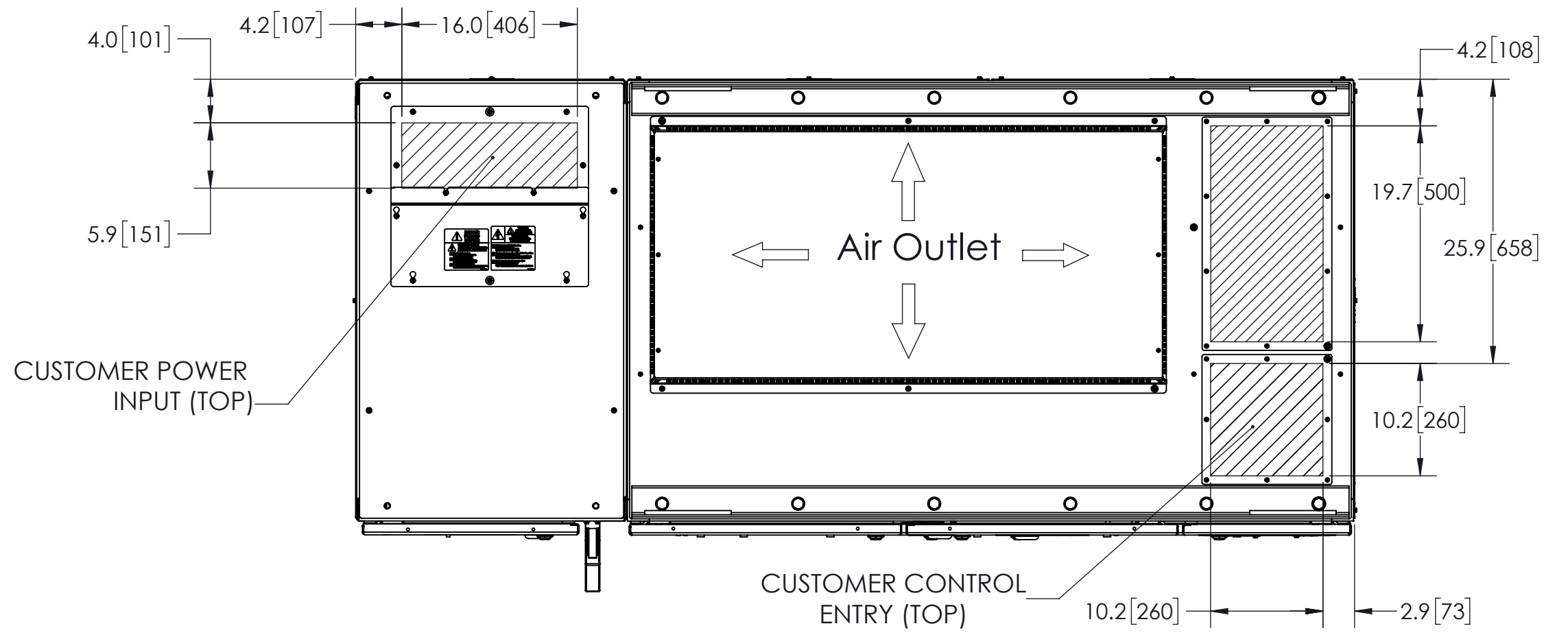

NOTES:
 1. FOR REFERENCE UNLESS PROPERLY ENDORSED. FOR ADDITIONAL DETAILS AND SPECIFICATIONS, CONSULT YASKAWA AMERICA, INC.
 2. DIMENSIONS ARE IN INCHES[MILLIMETERS]
 3. USE APPROPRIATE TYPE RATED HUBS OR FITTINGS TO MAINTAIN ENCLOSURE RATING.
 4. HATCHED AREA INDICATES PERMISSIBLE CABLE/CONDUIT ENTRANCE AREA.

REV.	DESCRIPTION	ECR#	DRAWN BY	DATE
01	<PG. 1> ADDED E-STOP, 3 OPERATORS. <PG. 2> ADDED REF. DESIGNATORS	8397	JSK	2/2/2018
00	INITIAL RELEASE	-	CJM	6/7/2016

jim_kaspravich Tuesday, February 6, 2018 2:13:07 PM

ENCLOSURE	UL TYPE 1
COLOR	OUTSIDE: BEIGE, MUNSELL 5Y7/1 (SEMI GLOSS) INSIDE: BEIGE, MUNSELL 5Y7/1 (SEMI GLOSS)

ITEM NO.	NAME
(XFMR)	TRANSFORMER CABINET
(CELL)	CELL CABINET
(CTRL)	CONTROL CABINET
(SG)	SWITCH GEAR CABINET
(LV)	LOW VOLTAGE CABINET

YASKAWA

DRAWN: C. Michalek 6/7/2016
 CHECKED: S. Tomczak 6/13/2016
 TITLE: DIMENSIONAL DRAWING, MV1000, FRM 1, W SG

THIS DOCUMENT AND INFORMATION CONTAINED IN IT ARE CONFIDENTIAL, AND CANNOT BE COPIED OR DISCLOSED IN WHOLE OR IN PART WITHOUT THE EXPRESS WRITTEN CONSENT OF YASKAWA AMERICA INC.

MATERIAL#	SEE TABLE
SIZE D	REVISION 01
DATE 6/28/2016	PAGE 1 OF 2

DRAWING #: DD.MV1K.FR1.N1.SG.01

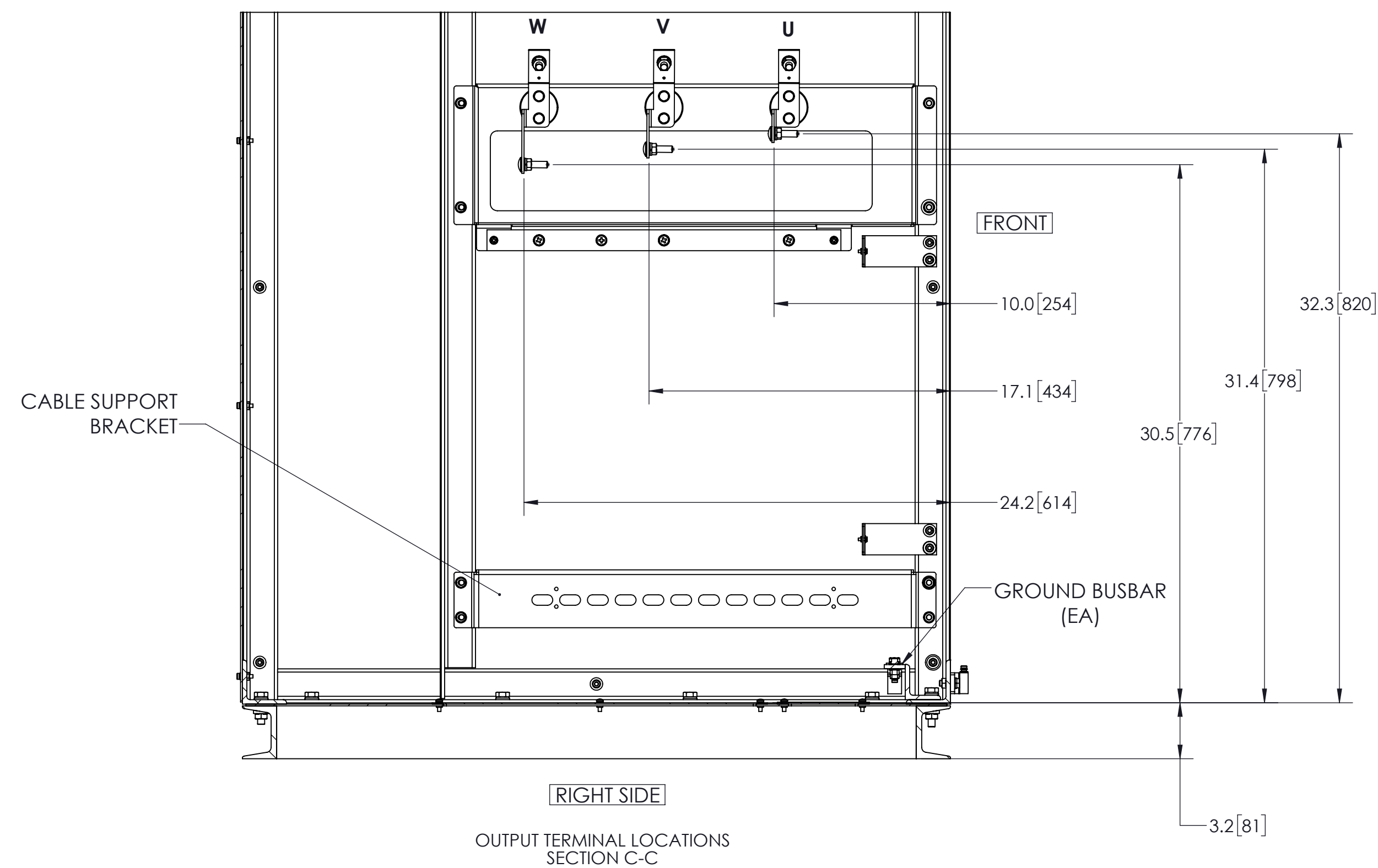
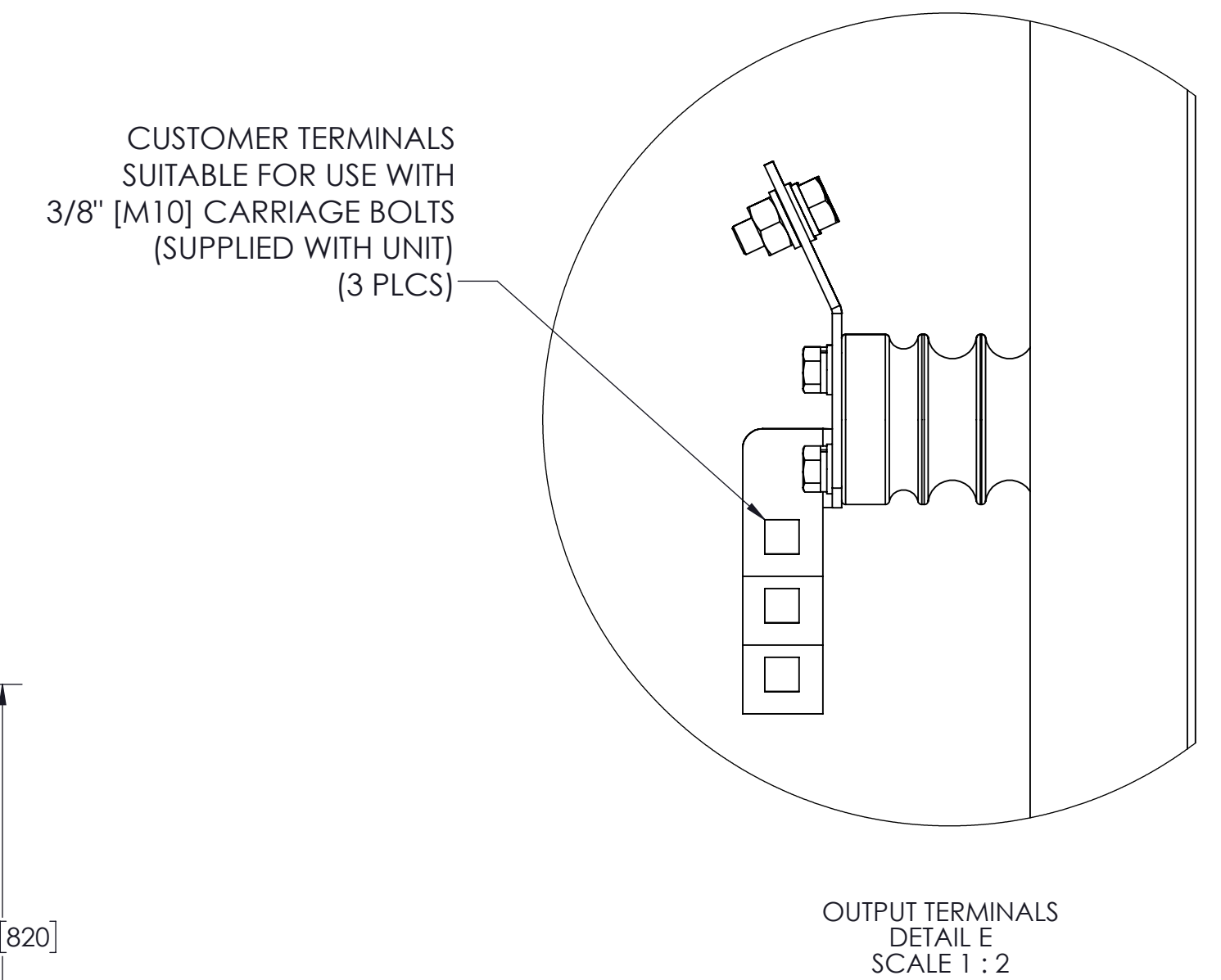
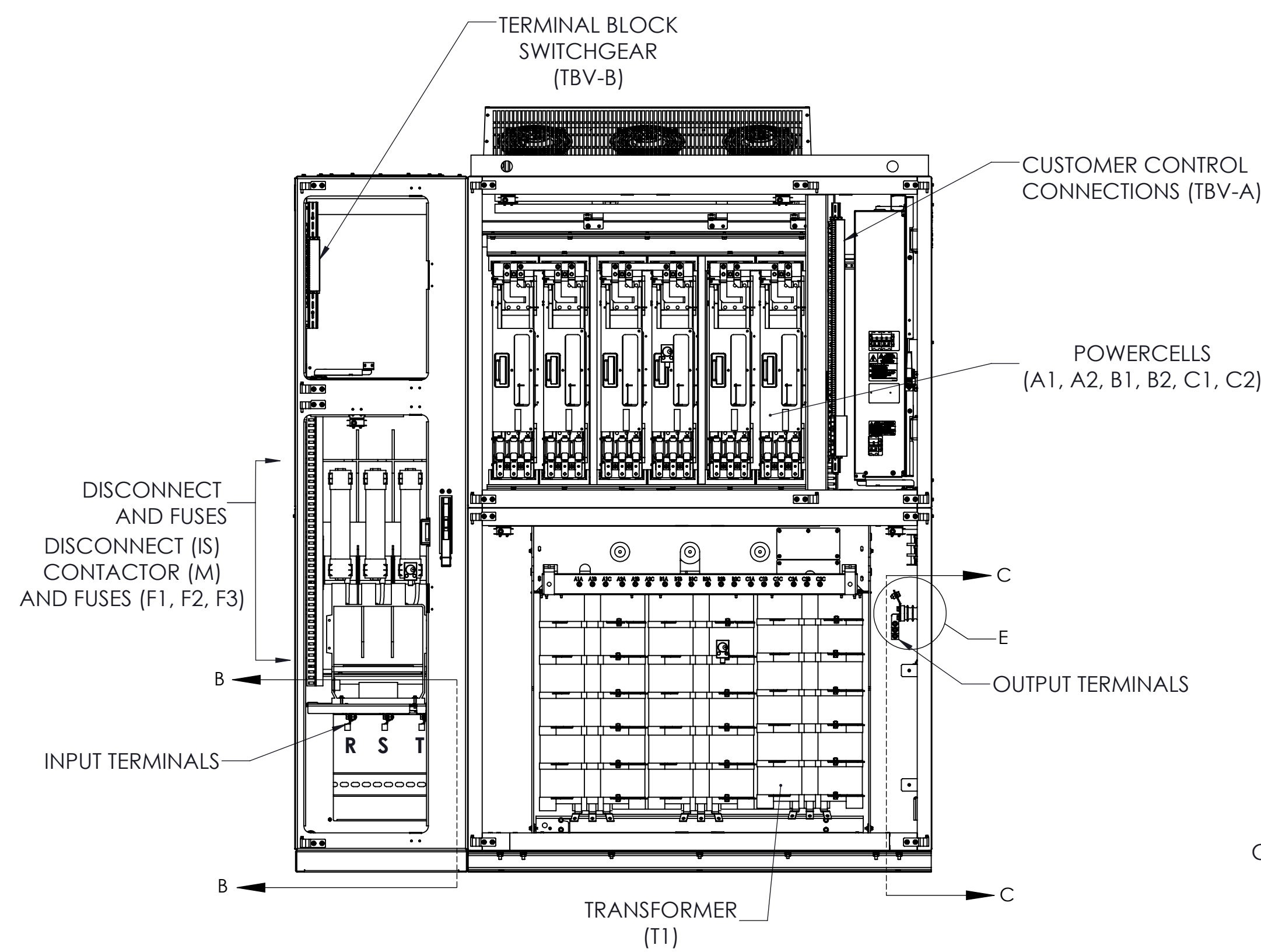
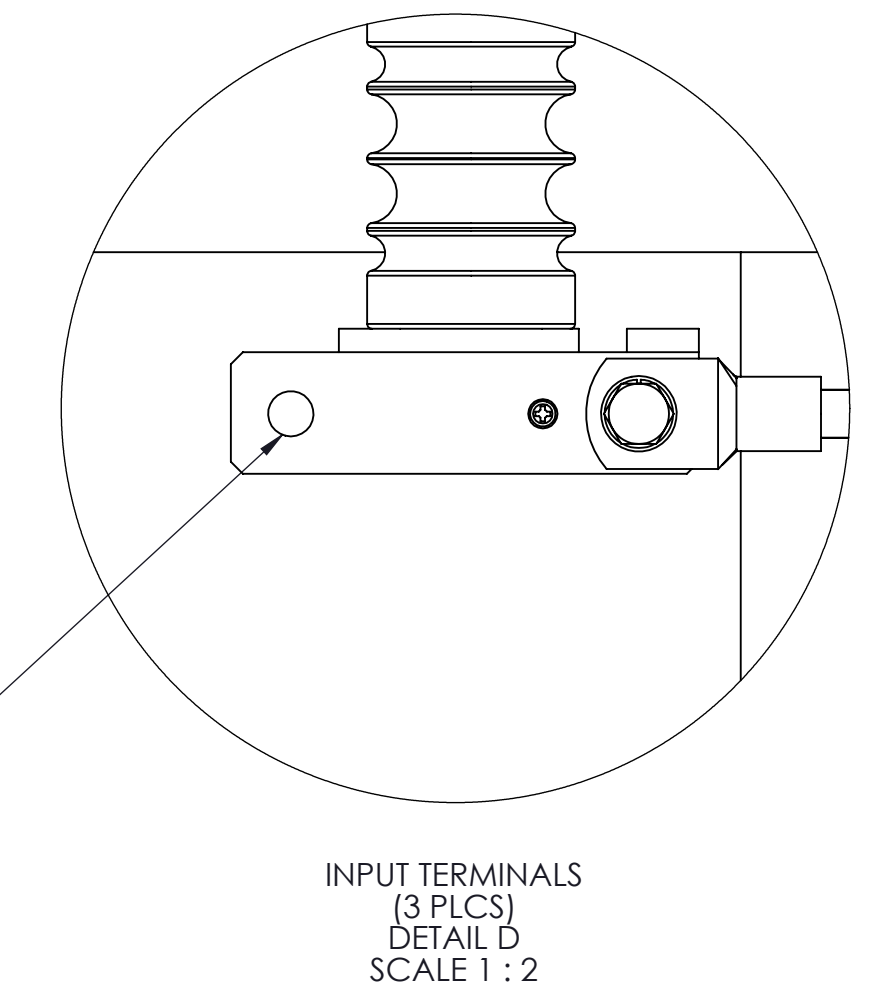
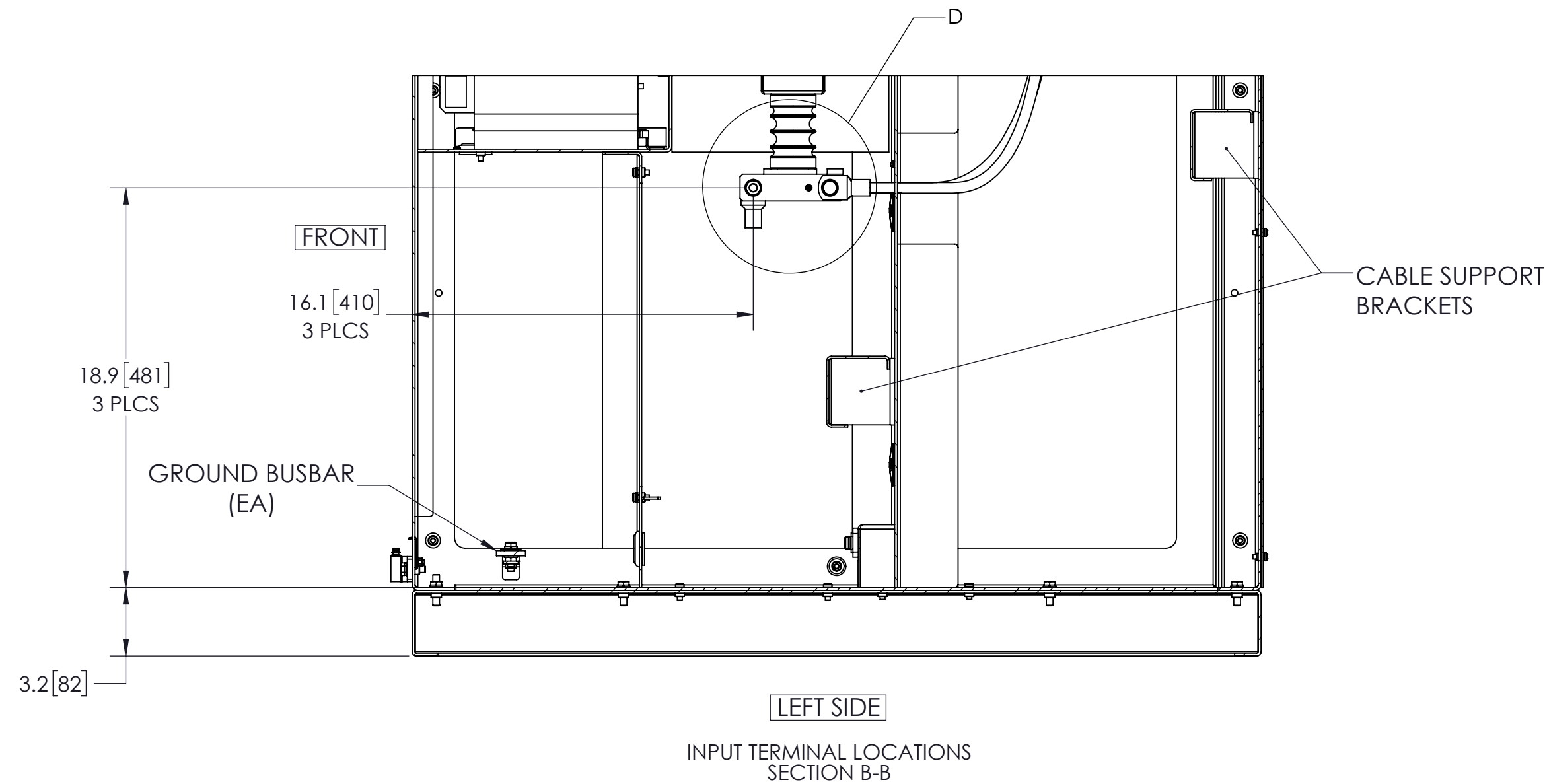
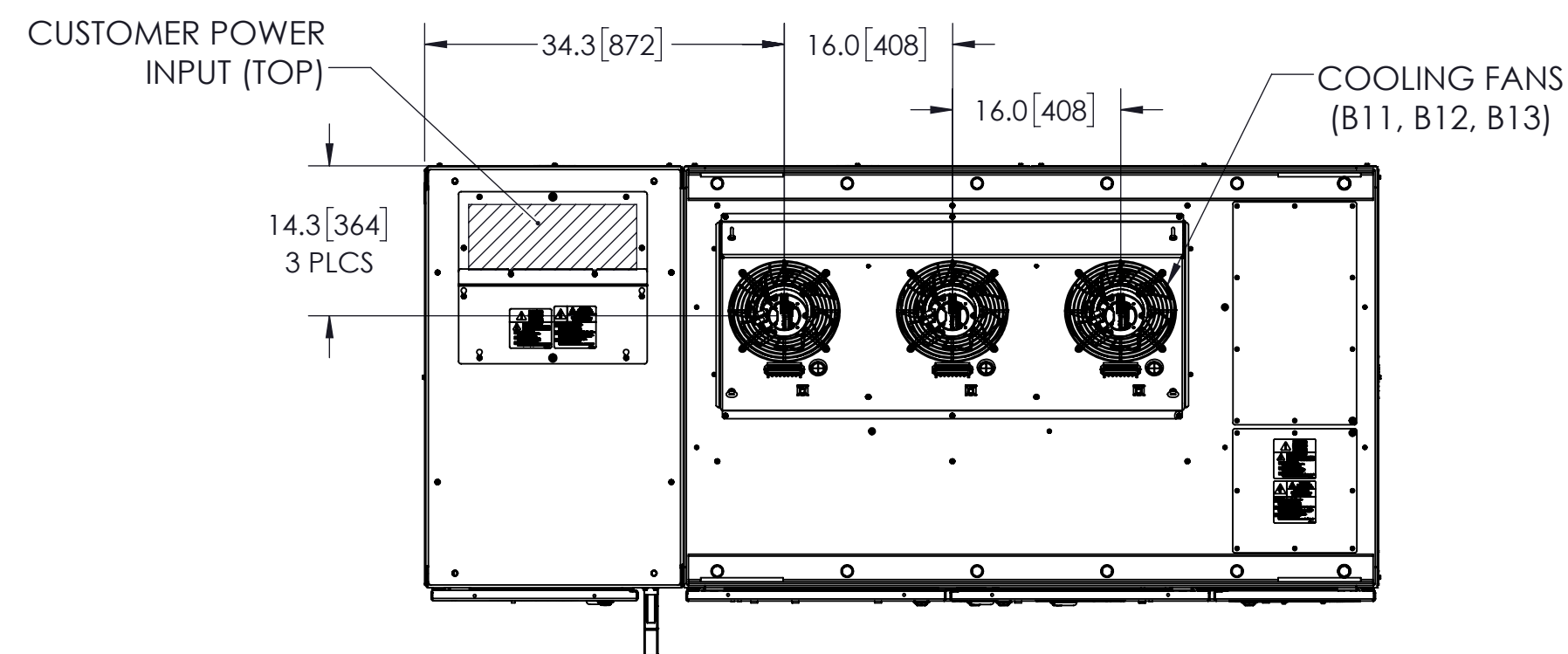

- NOTES:
- FOR REFERENCE UNLESS PROPERLY ENDORSED. FOR ADDITIONAL DETAILS AND SPECIFICATIONS, CONSULT YASKAWA AMERICA, INC.
 - DIMENSIONS ARE IN INCHES[MILLIMETERS]
 - USE APPROPRIATE TYPE RATED HUBS OR FITTINGS TO MAINTAIN ENCLOSURE RATING.
 - HATCHED AREA INDICATES PERMISSIBLE CABLE/CONDUIT ENTRANCE AREA.

YASKAWA		DRAWN: C. Michalek	DATE: 6/7/2016	TITLE: DIMENSIONAL DRAWING MV1000, FRM 1, W SG
		CHECKED: S. Tomczak	DATE: 6/13/2016	
		TECH: -	DATE: -	
		APPROVED: B. Johnson	DATE: 6/28/2016	
		ORIGINAL DESIGN: C. Michalek	DATE: 6/7/2016	
THIS DOCUMENT AND INFORMATION CONTAINED IN IT ARE CONFIDENTIAL, AND CANNOT BE COPIED OR DISCLOSED IN WHOLE OR IN PART WITHOUT THE EXPRESS WRITTEN CONSENT OF YASKAWA AMERICA INC.		MATERIAL#	SEE TABLE	
SIZE	REVISION	PAGE		
D	01	2 OF 2		
DRAWING #:			DD.MV1K.FR1.N1.SG.01	