

\* - INDICATES COMPONENTS NOT SUPPLIED BY YASKAWA.  
 - INDICATES CUSTOMER WIRING.  
 - CONNECTED TO THE CABINET OR PANEL.  
 SEE SHEET 2 FOR NOTES.  
 SEE DRAWING UDE00575 FOR CUSTOMER CONNECTIONS.  
 SEE DRAWING UDE00579 FOR DRIVE PARAMETER SETTINGS.

REVISIONS				
REV.	DESCRIPTION	ECD #	DRAWN BY	DATE
00	INITIAL RELEASE	-	KM	8/1/18

**YASKAWA**

THIS DOCUMENT AND INFORMATION CONTAINED IN IT ARE CONFIDENTIAL, AND CANNOT BE COPIED OR DISCLOSED IN WHOLE OR IN PART WITHOUT THE EXPRESS WRITTEN CONSENT OF YASKAWA AMERICA INC.

DRAWN BY: K. MALUSIC	DATE: 8/1/18	TITLE: SCHEMATIC DIAGRAM GA800 CONFIGURED HEAVY DUTY RATING TYPE 1
CHECKED: N. LAWS	DATE: 8/1/18	SIZE: D
APPROVED: K. FLIERL	DATE: 8/1/18	REVISION: 00
ORIGINAL DESIGN: K. MALUSIC	DATE: 8/1/18	PAGE: 1 of 2

DS.G8C1.01

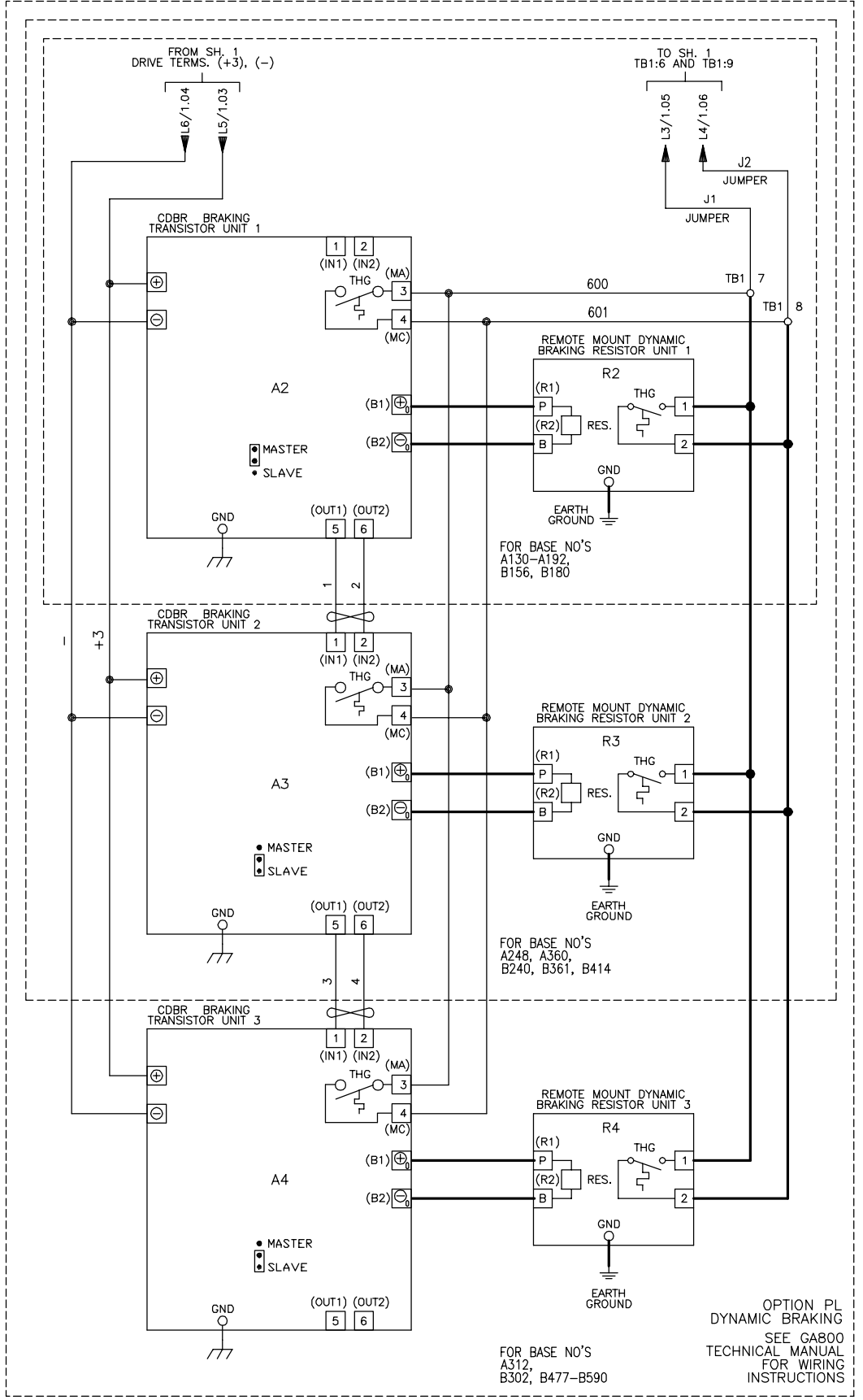

— INDICATES CUSTOMER WIRING.  
 - CONNECTED TO THE CABINET OR PANEL.

OPTION PL  
 DYNAMIC BRAKING  
 SEE GA800  
 TECHNICAL MANUAL  
 FOR WIRING  
 INSTRUCTIONS

NOTES:

- CONNECTED TO THE CABINET. CUSTOMER TO CONNECT THE CABINET GROUND LUG TO EARTH GROUND.
- CONDUIT FITTINGS/HUBS SHALL COMPLY WITH THE 'STANDARD FOR CONDUIT, TUBING, AND CABLE FITTINGS, UL 514B', OR CONDUIT FITTINGS HAVING THE SAME ENVIRONMENTAL RATING AS THE ENCLOSURE SHALL BE USED.
- WITHOUT THE CIRCUIT BREAKER (OPTION PC, PE OR PM), OR DISCONNECT SWITCH OPTION PD, THE DISCONNECT MEANS MUST BE SUPPLIED BY THE CUSTOMER.
- BRANCH CIRCUIT PROTECTION TO BE SUPPLIED BY THE CUSTOMER WHEN NOTED ON THE CABINET DATA NAMEPLATE.
- INSULATED TWISTED SHIELDED WIRE IS REQUIRED. SHIELD TO CONNECT TO PROPER TERMINALS AS SHOWN. CONNECT THE SHIELD ONLY AT THIS END. STUB AND ISOLATE THE OTHER END. DO NOT RUN THESE WIRES IN THE SAME CONDUIT AS THE AC POWER AND AC CONTROL WIRES. KEEP ALL WIRING UNDER 50m IN LENGTH.
- FOR A CONTROL TRANSFORMER T1 POWER RATING OF 350VA OR GREATER, SECONDARY FUSE F6 IS ADDED.
- IF AC MOTOR IS FURNISHED WITH A N.C. THERMAL SWITCH THEN SET DRIVE PARAMETER H1-08 TO 27. THIS WILL CAUSE THE DRIVE TO COAST TO STOP UPON A AC MOTOR THERMAL FAULT. ALONG WITH THIS, ADD THE FOLLOWING CUSTOMER WIRING: WIRE THE N.C. THERMAL SWITCH BETWEEN DRIVE TERMINALS S8 AND SN, AS PER NOTE 5 ABOVE.
- OPTIONS TC, TD, TG, TH OR TQ CONTROL (SEE UDE00579 FOR MORE INFORMATION):  
 OPTION TC = PROFINET  
 OPTION TD = ETHERNET/IP  
 OPTION TG = DEVICENET  
 OPTION TH = PROFIBUS  
 OPTION TQ = ETHERNET MODBUS TCP/IP
- DRIVE INPUT FUSES F3, F4, F5 ARE INCLUDED WITH OPTION PE, PC, PM OR PJ FOR BASE NUMBERS B004-B590.

<b>YASKAWA</b>		DRAWN BY: K. MALUSIC	DATE: 8/1/18	TITLE: SCHEMATIC DIAGRAM GA800 CONFIGURED HEAVY DUTY RATING TYPE 1	
		CHECKED: N. LAWS	DATE: 8/1/18	SIZE: D	REVISION: 00
THIS DOCUMENT AND INFORMATION CONTAINED IN IT ARE CONFIDENTIAL, AND CANNOT BE COPIED OR DISCLOSED IN WHOLE OR IN PART WITHOUT THE EXPRESS WRITTEN CONSENT OF YASKAWA AMERICA INC.		TECHNICAL: K. FLIERL	DATE: 8/1/18	DRAWING #: DS.G8C1.01	
		APPROVED: K. MALUSIC	DATE: 8/1/18		

REVISIONS				
REV	DESCRIPTION	ECD #	DRAWN BY	DATE
00	INITIAL RELEASE	-	KM	8/1/18