

CONTROL TRANSFORMER PRIMARY CONNECTIONS

INPUT VOLTS	TERMINALS		JUMPER LOCATION
	A	B	
230/240	(H1)	(H4)	(H1) TO (H3) (H2) TO (H4)
460/480	(H1)	(H4)	(H2) TO (H3)
600	(H1)	(H2)	NONE

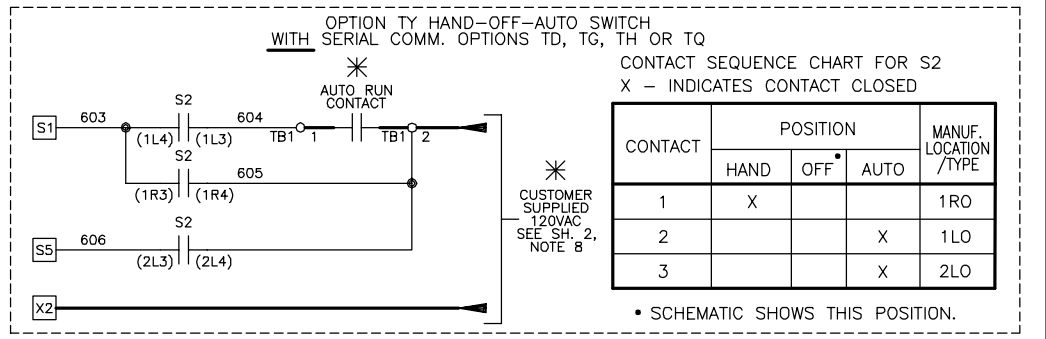
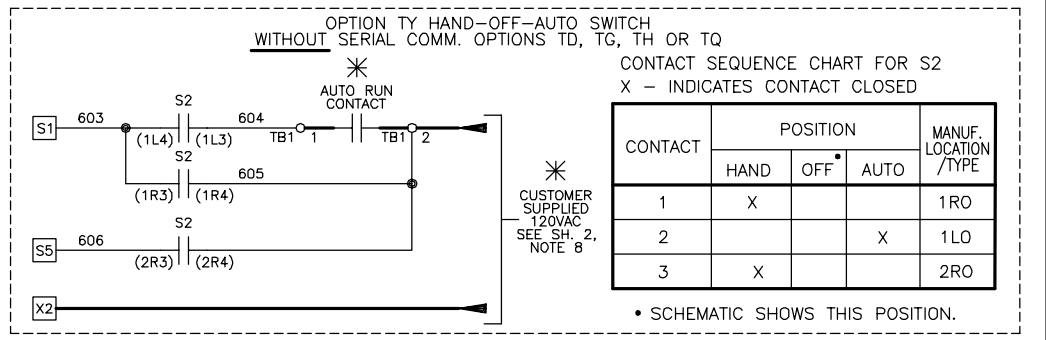
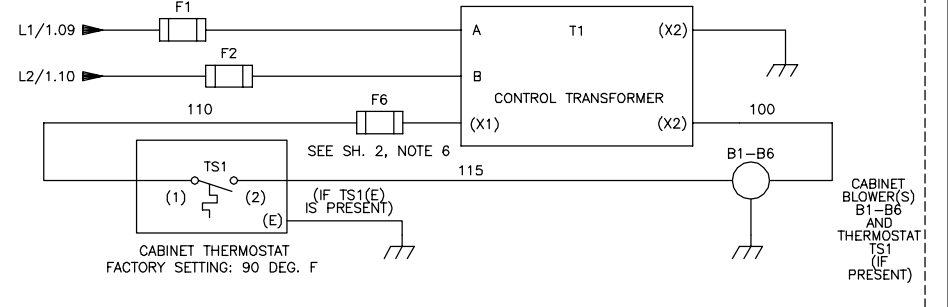

REVISIONS

REV	DESCRIPTION	ECD #	DRAWN BY	DATE
00	INITIAL RELEASE	-	KM	8/1/18

YASKAWA

THIS DOCUMENT AND INFORMATION CONTAINED IN IT ARE CONFIDENTIAL, AND CANNOT BE COPIED OR DISCLOSED IN WHOLE OR IN PART WITHOUT THE EXPRESS WRITTEN CONSENT OF YASKAWA AMERICA, INC.

DRAWN BY: K. MALUSIC	DATE: 8/1/18	TITLE: SCHEMATIC DIAGRAM G800 CONFIGURED TYPE 1 HEAVY DUTY RATING WITH OPTION TV
CHECKED: N. LAWS	DATE: 8/1/18	SIZE: D
TECH:	DATE:	REVISION: 00
APPROVED: K. FLIERL	DATE: 8/1/18	PAGE: 1 of 2
ORIGINAL DESIGN: K. MALUSIC	DATE: 8/1/18	DRAWING #: DS.G8C1.05

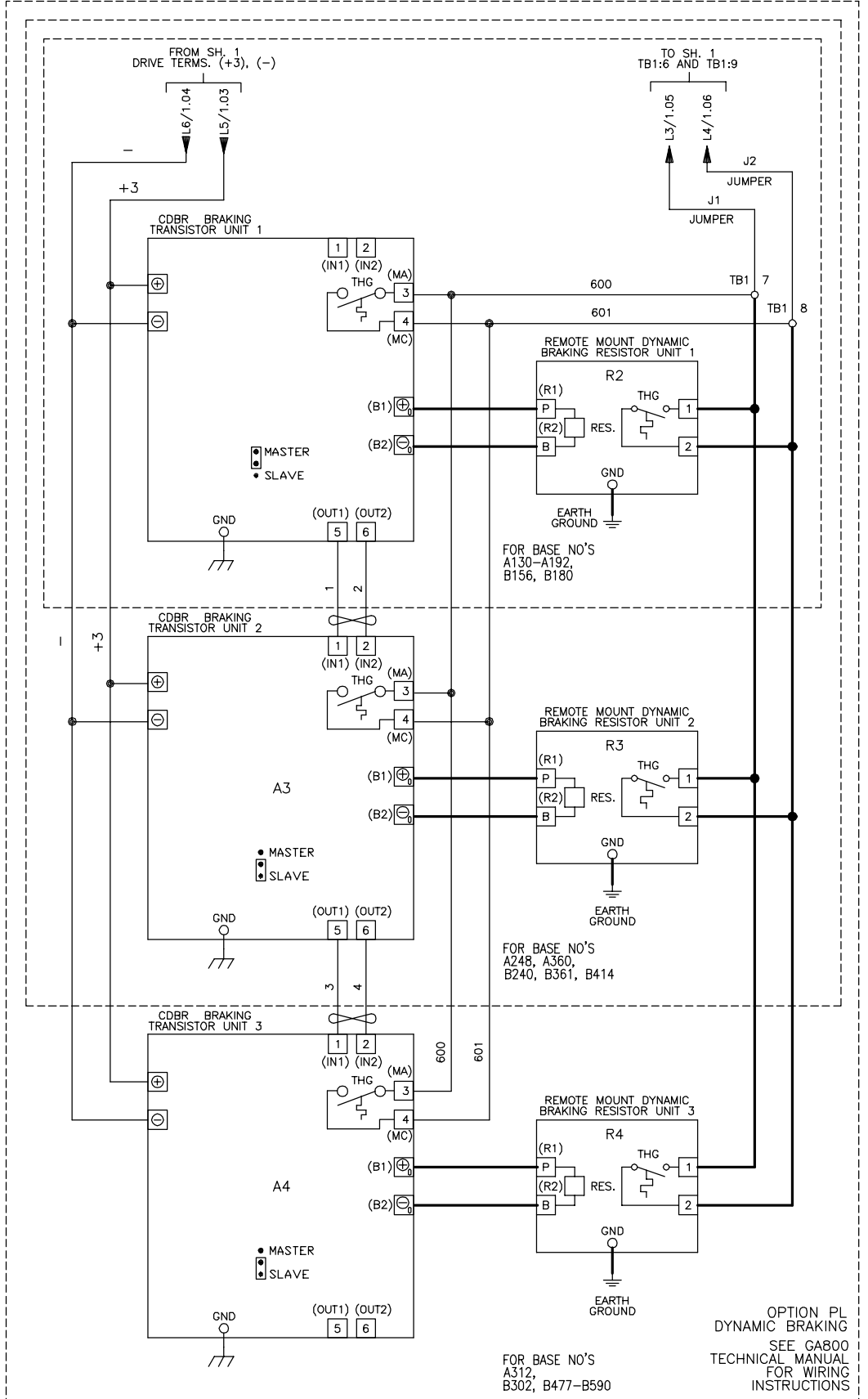

— INDICATES CUSTOMER WIRING.
 - CONNECTED TO THE CABINET OR PANEL.

OPTION PL
 DYNAMIC BRAKING
 SEE GA800
 TECHNICAL MANUAL
 FOR WIRING
 INSTRUCTIONS

NOTES:

- CONNECTED TO THE CABINET. CUSTOMER TO CONNECT THE CABINET GROUND LUG TO EARTH GROUND.
- CONDUIT FITTINGS/HUBS SHALL COMPLY WITH THE 'STANDARD FOR CONDUIT, TUBING, AND CABLE FITTINGS, UL 514B', OR CONDUIT FITTINGS HAVING THE SAME ENVIRONMENTAL RATING AS THE ENCLOSURE SHALL BE USED.
- WITHOUT THE CIRCUIT BREAKER (OPTION PC, PE OR PM), OR DISCONNECT SWITCH OPTION PD, THE DISCONNECT MEANS MUST BE SUPPLIED BY THE CUSTOMER.
- BRANCH CIRCUIT PROTECTION TO BE SUPPLIED BY THE CUSTOMER WHEN NOTED ON THE CABINET DATA NAMEPLATE.
- INSULATED TWISTED SHIELDED WIRE IS REQUIRED. SHIELD TO CONNECT TO PROPER TERMINALS AS SHOWN. CONNECT THE SHIELD ONLY AT THIS END. STUB AND ISOLATE THE OTHER END. DO NOT RUN THESE WIRES IN THE SAME CONDUIT AS THE AC POWER AND AC CONTROL WIRES. KEEP ALL WIRING UNDER 50m IN LENGTH.
- FOR A CONTROL TRANSFORMER T1 POWER RATING OF 350VA OR GREATER, SECONDARY FUSE F6 IS ADDED.
- IF AC MOTOR IS FURNISHED WITH A N.C. THERMAL SWITCH THEN SET DRIVE PARAMETER H1-08 TO 27. THIS WILL CAUSE THE DRIVE TO COAST TO STOP UPON A AC MOTOR THERMAL FAULT. ALONG WITH THIS, ADD THE FOLLOWING CUSTOMER WIRING: WIRE THE N.C. THERMAL SWITCH BETWEEN TERMINAL S8 OF THE 120VAC INTERFACE CARD AND ONE SIDE OF THE 120VAC SOURCE.
- CUSTOMER MUST PROVIDE PROPER SHORT CIRCUIT PROTECTION AND MEANS OF DISCONNECT.
- OPTIONS TC, TD, TG, TH OR TQ CONTROL (SEE UDE00579 FOR MORE INFORMATION):
 OPTION TC = PROFINET
 OPTION TD = ETHERNET/IP
 OPTION TG = DEVICENET
 OPTION TH = PROFIBUS
 OPTION TQ = ETHERNET MODBUS TCP/IP
- DRIVE INPUT FUSES F3, F4, F5 ARE INCLUDED WITH OPTION PE, PC, PM OR PJ FOR BASE NUMBERS B004-B590.

YASKAWA		DRAWN BY: K. MALUSIC	DATE: 8/1/18	TITLE: SCHEMATIC DIAGRAM GA800 CONFIGURED TYPE 1 HEAVY DUTY RATING WITH OPTION TV	
		CHECKED BY: N. LAWS	DATE: 8/1/18	SIZE: D	REVISION: 00
		TECHNICAL: K. FLIERL	DATE: 8/1/18	PAGE: 2 of 2	
		APPROVED BY: K. MALUSIC	DATE: 8/1/18	DRAWING #: DS.G8C1.05	

REVISIONS					
REV	DESCRIPTION	ECD #	DRAWN BY	DATE	
00	INITIAL RELEASE	-	KM	8/1/18	