

CONTROL TRANSFORMER PRIMARY CONNECTIONS			
INPUT VOLTS	TERMINALS		JUMPER LOCATION
	A	B	
230/240	(H1)	(H4)	(H1) TO (H3) (H2) TO (H4)
460/480	(H1)	(H4)	(H2) TO (H3)
600	(H1)	(H2)	NONE

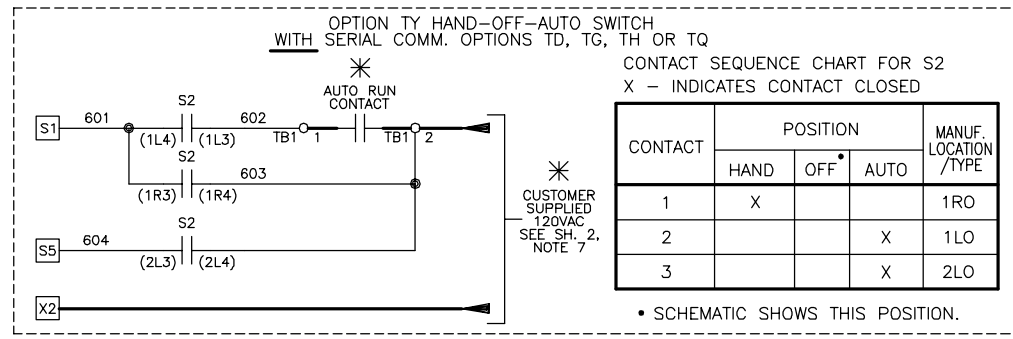
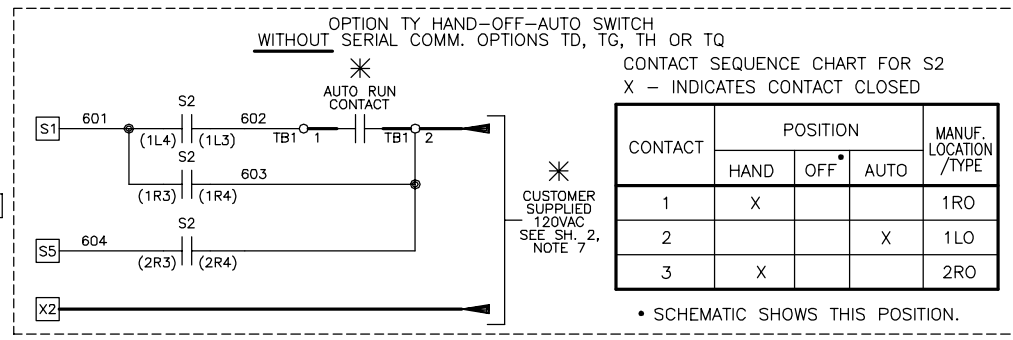
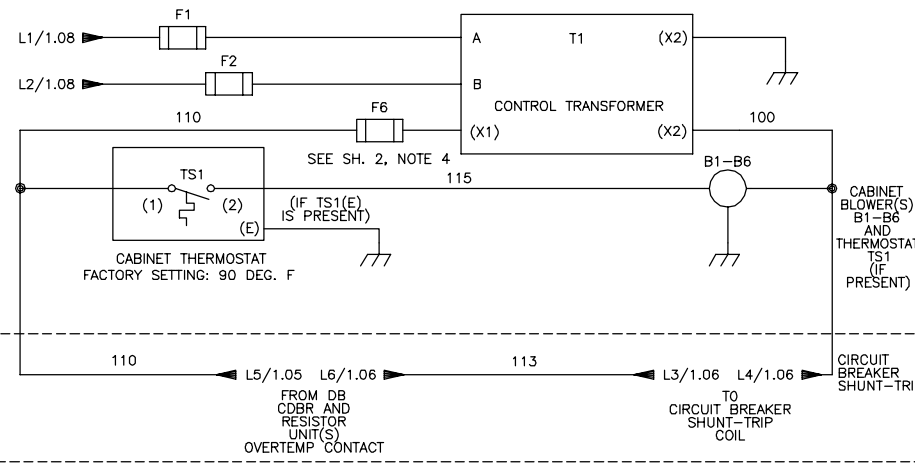

* - INDICATES COMPONENTS NOT SUPPLIED BY YASKAWA.
 - - INDICATES CUSTOMER WIRING.
 - - CONNECTED TO THE CABINET OR PANEL.
 SEE SHEET 2 FOR NOTES.
 SEE DRAWING UDE00578 FOR CUSTOMER CONNECTIONS.
 SEE DRAWING UDE00579 FOR DRIVE PARAMETER SETTINGS.

REVISIONS			
REV	DESCRIPTION	ECD #	DATE
00	INITIAL RELEASE	-	8/1/18

YASKAWA

THIS DOCUMENT AND INFORMATION CONTAINED IN IT ARE CONFIDENTIAL, AND CANNOT BE COPIED OR DISCLOSED IN WHOLE OR IN PART WITHOUT THE EXPRESS WRITTEN CONSENT OF YASKAWA AMERICA INC.

DRAWN BY: K. MALUSIC	DATE: 8/1/18	TITLE: SCHEMATIC DIAGRAM G800 CONFIGURED TYPE 1 NORMAL DUTY RATING WITH OPTION PJ, TV AND PH
CHECKED: N. LAWS	DATE: 8/1/18	SIZE: D
TECH: K. FLIERL	DATE: 8/1/18	REVISION: 00
APPROVED: K. FLIERL	DATE: 8/1/18	PAGE: 1 of 2
ORIGINAL DESIGN: K. MALUSIC	DATE: 8/1/18	DRAWING #: DS.G8C1.16

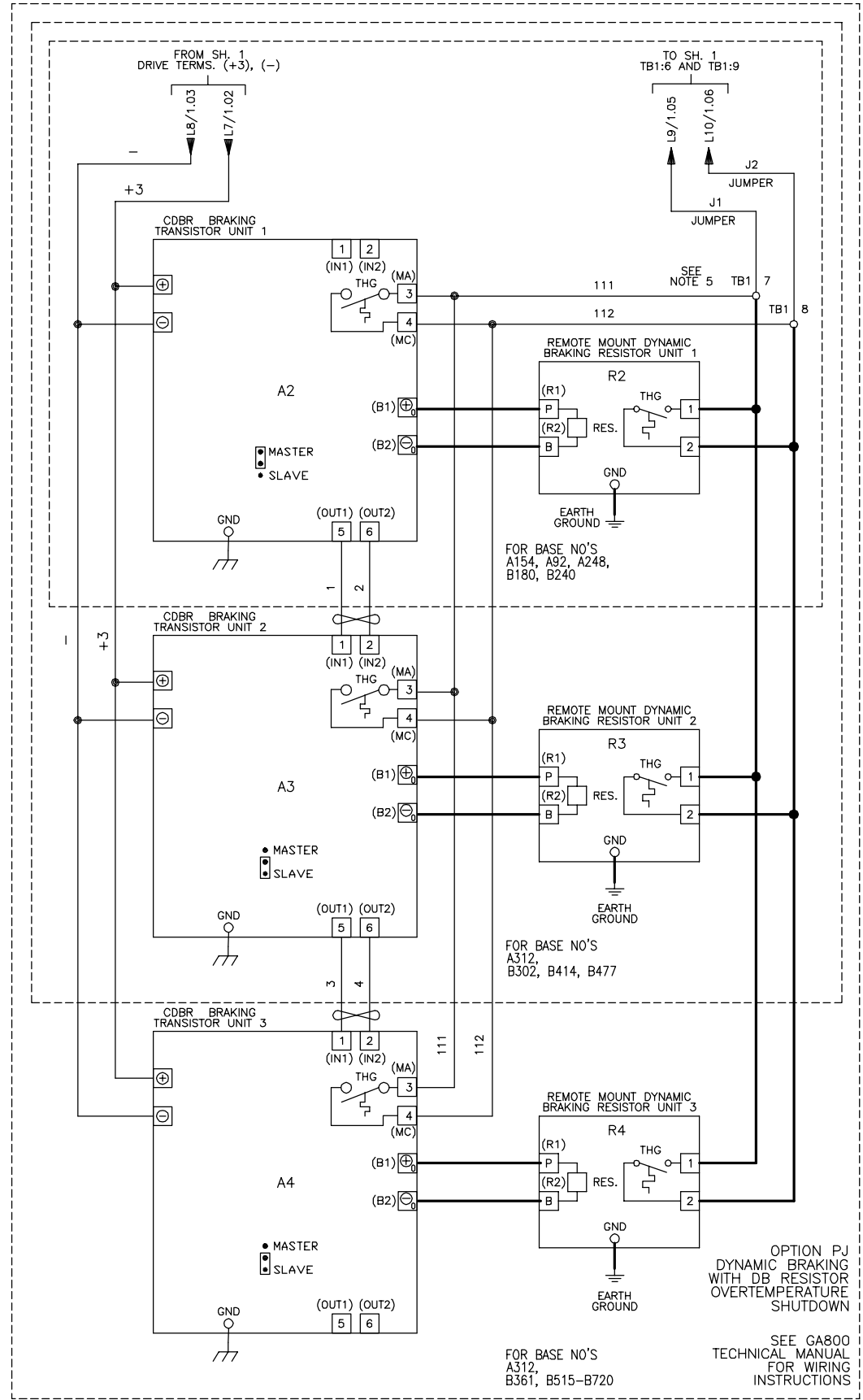

— INDICATES CUSTOMER WIRING.
⏏ - CONNECTED TO THE CABINET OR PANEL.

NOTES:

- CONNECTED TO THE CABINET. CUSTOMER TO CONNECT THE CABINET GROUND LUG TO EARTH GROUND.
- CONDUIT FITTINGS/HUBS SHALL COMPLY WITH THE 'STANDARD FOR CONDUIT, TUBING, AND CABLE FITTINGS, UL 514B'. OR CONDUIT FITTINGS HAVING THE SAME ENVIRONMENTAL RATING AS THE ENCLOSURE SHALL BE USED.
- INSULATED TWISTED SHIELDED WIRE IS REQUIRED. SHIELD TO CONNECT TO PROPER TERMINALS AS SHOWN. CONNECT THE SHIELD ONLY AT THIS END. STUB AND ISOLATE THE OTHER END. DO NOT RUN THESE WIRES IN THE SAME CONDUIT AS THE AC POWER AND AC CONTROL WIRES. KEEP ALL WIRING UNDER 50m IN LENGTH.
- FOR A CONTROL TRANSFORMER T1 POWER RATING OF 350VA OR GREATER, SECONDARY FUSE F6 IS ADDED.
- CUSTOMER TO CONNECT NORMALLY OPEN BRAKING RESISTOR THERMAL SWITCHES PER THE GA800 TECHNICAL MANUAL IN PARALLEL WITH TB1-7 AND TB1-8.
- IF AC MOTOR IS FURNISHED WITH A N.C. THERMAL SWITCH THEN SET DRIVE PARAMETER H1-08 TO 27. THIS WILL CAUSE THE DRIVE TO COAST TO STOP UPON A AC MOTOR THERMAL FAULT. ALONG WITH THIS, ADD THE FOLLOWING CUSTOMER WIRING: WIRE THE N.C. THERMAL SWITCH BETWEEN TERMINAL S8 OF THE 120VAC INTERFACE CARD AND ONE SIDE OF THE 120VAC SOURCE.
- CUSTOMER MUST PROVIDE PROPER SHORT CIRCUIT PROTECTION AND MEANS OF DISCONNECT.
- OPTIONS TC, TD, TG, TH OR TQ CONTROL (SEE UDE00579 FOR MORE INFORMATION):
OPTION TC = PROFINET
OPTION TD = ETHERNET/IP
OPTION TG = DEVICENET
OPTION TH = PROFIBUS
OPTION TQ = ETHERNET MODBUS TCP/IP
- DRIVE INPUT FUSES F3, F4, F5 ARE INCLUDED WITH OPTION PE, PC, PM OR PJ FOR BASE NUMBERS B007-B720.

REVISIONS				
REV	DESCRIPTION	ECD #	DRAWN BY	DATE
00	INITIAL RELEASE	-	KM	8/1/18

YASKAWA	DRAWN BY: K. MALUSIC	DATE: 8/1/18	TITLE: SCHEMATIC DIAGRAM GA800 CONFIGURED TYPE 1 NORMAL DUTY RATING WITH OPTION PJ,TV AND PH		
	CHECKED BY: N. LAWS	DATE: 8/1/18	SIZE: D	REVISION: 00	PAGE: 2 of 2
	APPROVED BY: K. FLIERL	DATE: 8/1/18	DRAWING #: DS.G8C1.16		
	ORIGINAL DESIGN: K. MALUSIC	DATE: 8/1/18			

THIS DOCUMENT AND INFORMATION CONTAINED IN IT ARE CONFIDENTIAL, AND CANNOT BE COPIED OR DISCLOSED IN WHOLE OR IN PART WITHOUT THE EXPRESS WRITTEN CONSENT OF YASKAWA AMERICA INC.