

* - INDICATES COMPONENTS NOT SUPPLIED BY YASKAWA.
 - - INDICATES CUSTOMER WIRING.
 ⏏ - CONNECTED TO THE CABINET OR PANEL.
 SEE DRAWING UDE00641 FOR CUSTOMER CONNECTION TABLES.

REVISIONS				
REV.	DESCRIPTION	ECO #	DRAWN BY	DATE
01	CHANGED CN2-1 TO CN2-2, ADDED OPTION T3	12564	R.JJ	09/02/22
00	INITIAL RELEASE	--	NSL	8/6/20

YASKAWA	DRAWN BY:	N. LAWS	DATE:	8/6/20	TITLE:	SCHEMATIC DIAGRAM				
	CHECKED:	K. PEOPLES	DATE:	8/7/20		HV600 TYPE 3R CONFIGURED				
	APPROVED:	R. JENSEN	DATE:	8/10/20	SIZE:	D	REVISION:	01	PAGE:	1 of 2
	ORIGINAL DESIGNER:	N. LAWS	DATE:	8/6/20	DRAWING #:	DS.H6C3.01				

THIS DOCUMENT AND INFORMATION CONTAINED IN IT ARE CONFIDENTIAL, AND CANNOT BE COPIED OR DISCLOSED IN WHOLE OR IN PART WITHOUT THE EXPRESS WRITTEN CONSENT OF YASKAWA AMERICA INC.

201
202
203
204
205
206
207
208
209
210
211
212
213
214
215
216
217
218
219
220
221
222
223
224
225
226
227
228
229
230
231
232
233
234
235
236
237
238
239
240
241

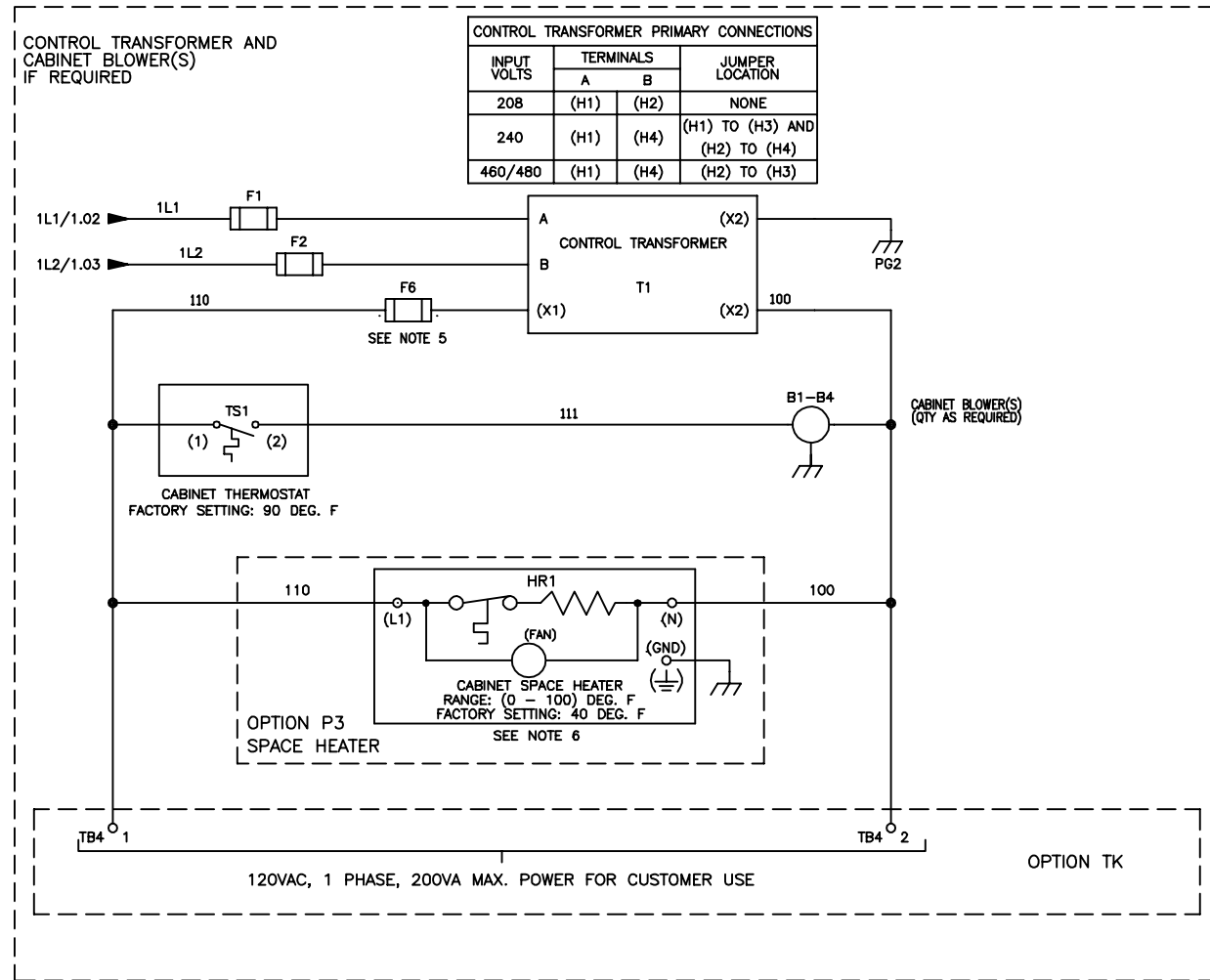

- NOTES:
1. CUSTOMER TO CONNECT THE CABINET GROUND LUG TO EARTH GROUND AND UTILITY GROUND.
 2. WHEN INPUT CIRCUIT BREAKER OPTION PM IS NOT PROVIDED, BRANCH CIRCUIT PROTECTION MUST BE SUPPLIED BY THE INSTALLER.
 3. FOR 208VAC APPLICATIONS SET PARAMETERS E1-01 AND E1-05 TO 208.
 4. FOR SPEED POT OPTION TZ, SET H3-02 TO 2E, L4-05 TO 0, AND S5-01 TO 0
 5. WITH A CONTROL POWER TRANSFORMER T1, POWER RATING 350VA OR GREATER, SECONDARY FUSE F6 IS ADDED.
 6. CUSTOMER TO ADJUST THE THERMOSTAT ON THE SPACE HEATER HR1 FOR THE MINIMUM DESIRED TEMPERATURE INSIDE THE DRIVE CABINET. THIS SET TEMPERATURE IS NORMALLY SELECTED TO BE SLIGHTLY HIGHER THAN THE MINIMUM AMBIENT TEMPERATURE OF THE AIR SURROUNDING THE CABINET, AND IS THE TEMPERATURE AT WHICH THE SPACE HEATER HR1 WILL SHUT OFF.
 7. CONDUIT FITTINGS/HUBS SHALL COMPLY WITH THE 'STANDARD FOR CONDUIT, TUBING, AND CABLE FITTINGS, UL 514B'. OR CONDUIT FITTINGS HAVING THE SAME ENVIRONMENTAL RATING AS THE ENCLOSURE SHALL BE USED.

YASKAWA	DRAWN BY: N. LAWS	DATE: 8/6/20	TITLE: SCHEMATIC DRAWING HV600 TYPE 3r CONFIGURED			
	CHECKED BY: K. PEOPLES	DATE: 8/7/20				
<small>THIS DOCUMENT AND INFORMATION CONTAINED HEREIN ARE CONFIDENTIAL, AND CANNOT BE COPIED OR DISCLOSED IN WHOLE OR IN PART WITHOUT THE EXPRESS WRITTEN CONSENT OF YASKAWA AMERICA INC.</small>			<table border="1"> <tr> <td>SIZE: D</td> <td>REVISION: 01</td> <td>PAGE: 2 of 2</td> </tr> </table>	SIZE: D	REVISION: 01	PAGE: 2 of 2
SIZE: D	REVISION: 01	PAGE: 2 of 2				
APPROVED BY: R. JENSEN	DATE: 8/10/20	DRAWING #: DS.H6C3.01				
ORIGINAL DESIGNED BY: N. LAWS	DATE: 8/6/20					