

**CONTROL TRANSFORMER PRIMARY CONNECTIONS**

INPUT VOLTS	TERMINALS		JUMPER LOCATION
	A	B	
208	(H1)	(H2)	NONE
460/480	(H1)	(H4)	(H2) TO (H3)

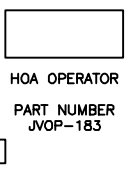
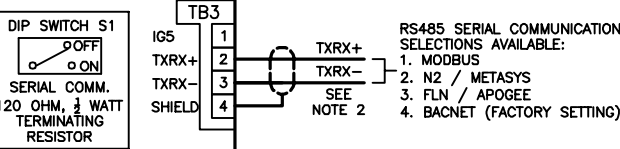
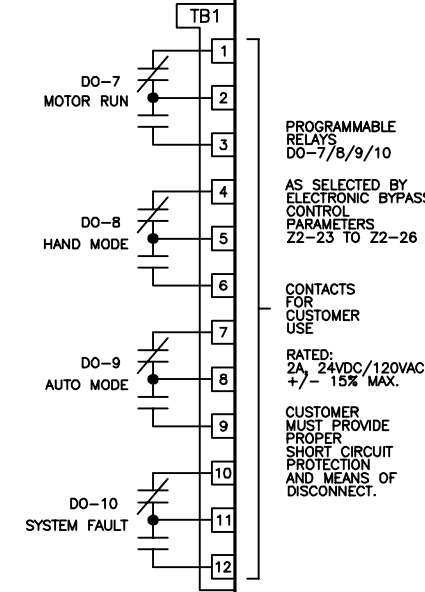
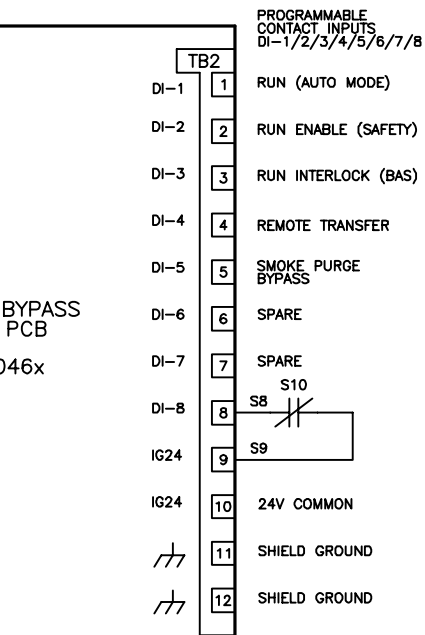
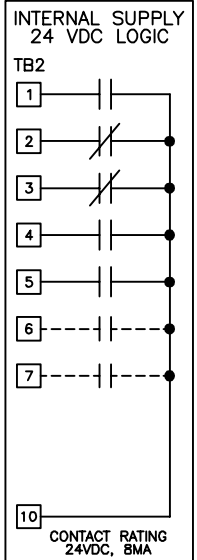

- NOTES:**
1. CUSTOMER TO CONNECT THE CABINET GROUND LUG TO EARTH GROUND.
  2. INSULATED TWISTED SHIELDED WIRE IS REQUIRED. SHIELD TO CONNECT TO PROPER TERMINAL AS SHOWN. CONNECT THE SHIELD ONLY AT THIS END. STUB AND ISOLATE THE OTHER END. DO NOT RUN THESE WIRES IN THE SAME CONDUIT AS THE AC POWER AND THE AC CONTROL WIRES.
  3. WITH A CONTROL TRANSFORMER, T1, POWER RATING 350VA OR GREATER, SECONDARY FUSE F6 IS ADDED.
  4. CHANGING Z1-01 TO "1" WILL PROGRAM THE DRIVE AND BYPASS PARAMETERS TO THEIR FACTORY DEFAULT SETTINGS.
  5. FOR 208VAC APPLICATIONS, SET E1-01 TO 208 AND SET E1-05 TO 208.
  6. THE MOTOR OVERLOAD RELAY IS FACTORY SET FOR MANUAL RESET. CUSTOMER TO ADJUST THE MOTOR OVERLOAD RELAY TRIP SETTING FOR THE ACTUAL AC MOTOR'S FULL LOAD AMPS.
  7. CONDUIT FITTINGS/HUBS SHALL COMPLY WITH THE "STANDARD FOR CONDUIT, TUBING, AND CABLE FITTINGS, UL 514B". OR CONDUIT FITTINGS HAVING THE SAME ENVIRONMENTAL RATING AS THE ENCLOSURE SHALL BE USED.

- \* - INDICATES COMPONENTS NOT SUPPLIED BY YASKAWA.
- - INDICATES CUSTOMER WIRING.
- ⏏ - CONNECTED TO THE CABINET OR PANEL.

**REVISIONS**

REV.	DESCRIPTION	ECO #	DRAWN BY	DATE
04	REMOVE TG & TH OPTIONS FROM P1000 BYPASS	12946	JZ	3/13/23
03	CHANGED REACTOR L4 TERMINAL DESIGNATORS	7695	R.ROH	11/16/17

**YASKAWA**

*THIS DOCUMENT AND INFORMATION CONTAINED IN IT ARE CONFIDENTIAL, AND CANNOT BE COPIED OR DISCLOSED IN WHOLE OR IN PART WITHOUT THE EXPRESS WRITTEN CONSENT OF YASKAWA AMERICA INC.*

DRAWN BY D. CMELAK	DATE 11/30/13	TITLE SCHEMATIC DIAGRAM P1000 ELECTRONIC BYPASS
CHECKED BY D. PACKER	DATE 11/30/13	SIZE D
TECH K. FLIERL	DATE 11/30/13	REVISION 04
APPROVED BY D. CMELAK	DATE 11/30/13	PAGE 1 of 1

**DS.P1B.112.04**