

- NOTES:
1. CUSTOMER TO CONNECT THE CABINET GROUND LUGS TO EARTH GROUND AND UTILITY GROUND.
 2. CONDUIT FITTINGS/HUBS SHALL COMPLY WITH THE 'STANDARD FOR CONDUIT, TUBING, AND CABLE FITTINGS, UL 514B', OR CONDUIT FITTINGS HAVING THE SAME ENVIRONMENTAL RATING AS THE ENCLOSURE SHALL BE USED.
 3. INSULATED TWISTED SHIELDED WIRE IS REQUIRED. SHIELD TO CONNECT TO PROPER TERMINAL AS SHOWN. CONNECT THE SHIELD ONLY AT THIS END. STUB AND ISOLATE THE OTHER END. DO NOT RUN THESE WIRES IN THE SAME CONDUIT AS THE AC POWER AND THE AC CONTROL WIRES.
 4. WITH A CONTROL TRANSFORMER, T1, POWER RATING 350VA OR GREATER, SECONDARY FUSE F6 IS ADDED.
 5. CHANGING Z1-01 TO "1" WILL PROGRAM THE DRIVE AND BYPASS PARAMETERS TO THEIR FACTORY DEFAULT SETTINGS.
 6. SET Z1-11 TO 4 AND Z2-06 TO 27.
 7. FOR 208VAC APPLICATIONS, SET E1-01 TO 208, AND SET E1-05 TO 208.
 8. THE MOTOR OVERLOAD RELAY IS FACTORY SET FOR MANUAL RESET. CUSTOMER TO ADJUST THE MOTOR OVERLOAD RELAY TRIP SETTING FOR THE ACTUAL AC MOTOR'S FULL LOAD AMPS.
 9. CUSTOMER TO ADJUST THE THERMOSTAT ON THE SPACE HEATER HR1 FOR THE MINIMUM DESIRED TEMPERATURE INSIDE THE DRIVE CABINET. THIS SET TEMPERATURE IS NORMALLY SELECTED TO BE SLIGHTLY HIGHER THAN THE MINIMUM AMBIENT TEMPERATURE OF THE AIR SURROUNDING THE CABINET. AND IS THE TEMPERATURE AT WHICH THE SPACE HEATER HR1 WILL SHUT OFF.

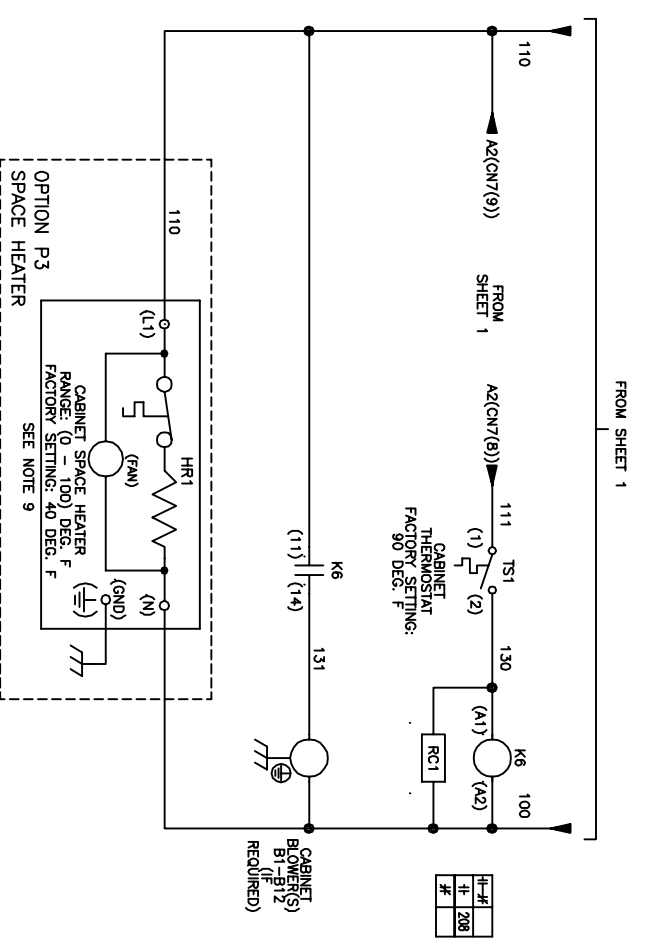

201

202

203

204

205

206

207

208

209

210

211

212

213

214

215

216

217

218

219

220

221

222

223

224

225

226

227

228

229

230

231

232

233

234

235

236

237

238

239

240

241

YASKAWA		DATE	4/23/13	TITLE	SCHEMATIC DIAGRAM BYPASS
DESIGNED BY	K. MALUSIC	CHECKED	D. CMEIAK	DATE	4/23/13
IN/IT ARE CONFIDENTIAL AND CANNOT BE COPIED OR DISCLOSED IN WHOLE OR IN PART WITHOUT THE EXPRESS WRITTEN CONSENT OF YASKAWA AMERICA INC.	APPROVED	DATE	4/23/13	OPTION	P3
	D.R. CMEIAK	DATE	4/23/13	SIZE	D
		DATE	4/23/13	REGION	03
		DATE	4/23/13	PAGE	2 of 2
		DATE	4/23/13	DRAWING #	DS.Z1B3.10