

## ENGINEERING PUBLICATION MOTION CONTROL DIVISION

**PRODUCT: SIGMA-5**  
**CATEGORY: TECH NOTES**

**SUBJECT: SGD V External ReGen Specifications**  
**DISTRIBUTION: MCD, Public**

---

Power returns to the SGD V servo amplifier when the servomotor is driven in the generator mode. This is called regenerative power. The regenerative power is absorbed by charging the bus smoothing capacitor in the SGD V. The regenerative resistor consumes the regenerative power when such power exceeds the chargeable energy of the capacitor. SGD V with capacities of 0.5 to 5 kW have built-in regenerative resistor with limited power capacities. SGD V servos with capacities of 6 kW or higher do not have built-in regenerative resistors so a regenerative resistor must be connected externally. Please refer to section 3.6 of the *Sigma-5 Series Servo System User's Manual* for more details.

Applications with high load to motor inertia mismatches may require additional regenerative capacity instead of the built-in amount. To add an external regenerative resistor to the SGD V, simply connect a resistor or resistor network between terminals B1 and B2. For SGD V servos with capacities of 0.5 to 5 kW, be sure to remove the jumper wire between terminals B2 and B3. User parameter Pn600 must be set to identify the external regenerative resistor's power capacity

The external regenerative equivalent resistance should be:

$$R_{\min} < R < (V^2 / P_{rg}) \quad \text{where } V=380 \text{ for } 100V \text{ \& } 200V \text{ units, } 760 \text{ for } 400V \text{ unit}$$

$P_{rg}$  is the needed regenerative power in watts

The maximum allowable power capacity of the external regeneration resistor is the rated power capacity of the SGD V. The minimum allowable resistance for SGD V amplifiers are listed below. External regenerative resistor must equal to or greater than this resistance.

Model #	Rmin ( $\Omega$ )
<b>100V:</b>	
SGDV-xxxF	40
<b>200V:</b>	
SGDV-R70A, R90A, 1R6A, 2R8A	40
SGDV-3R8A, 5R5A, 7R6A	40
SGDV-120A	20
SGDV-180A, 200A	12
SGDV-330A	8
SGDV-470A	5.8
SGDV-550A, 590A, 780A	2.9
<b>400V:</b>	
SGDV-1R9D, 3R5D, 5R4D	73
SGDV-8R4D, 120D	44
SGDV-170D	28
SGDV-210D, 260D	18
SGDV-280D, 370D	14.25

# YASKAWA

When power resistors are used at the rated load ratios the operating temperature rises to between 200°C and 300°C. The resistors must be used at below the rated values. Check with the manufacturer for resistor load characteristics. Use resistors at no more than 20% of the rated load ratio with natural convection cooling, and no more than 50% of the rated load ratio with forced-air cooling. For example, if the JUSP-RA04 is used in its factory configuration of 6.25 ohms, the allowable capacity is 176W (20% of 880W) with natural convection cooling, with forced-air cooling is 440W (50% of 880W). User Parmeter Pn600 must be set to the allowable capacity for the regen circuit in the SGD V to operate properly. In this example, Pn600 should be set to 18, 180W, with convection cooling.

When shipped from the factory, Yaskawa External Regeneration Unit JUSP-RA04 is pre-wired for the SGD V-470A, JUSP-RA05AE is pre-wired for the SGD V-550A, SGD V-590A, and SGD V-780A, JUSP-RA18 is pre-wired for the 400V SGD V-210D (6kW) and SGD V-260D (7.5kW) unit, JUSP-RA19 is pre-wired for the SGD V-280D (11kW) and SGD V-370D (15kW) unit.

Yaskawa External Regeneration Units JUSP-RA04, -RA05, -RA18, and -RA19 may also be rewired to achieve the needed equivalent resistances and power capacities. The rewiring procedure includes the removal of jumpers J1 and J2, and use of spare screw terminals P1 and P2. Please note that the power capacities indicated in the diagrams are before derating, refer to the paragraphs above for the proper derating level.

Yaskawa's External Regenerative Resistors listed in **Table 1** may also be used in single or multiple units in either series or parallel combinations to achieve the needed equivalent resistances and power capacities.

Yaskawa's servo sizing programs SigmaSelect or SigmaJunmaSize+ will automatically calculate and recommend the regeneration capacity required for an application.

**JUSP-RA04** (shipped pre-wire for  $6.25\Omega$ , 880W)

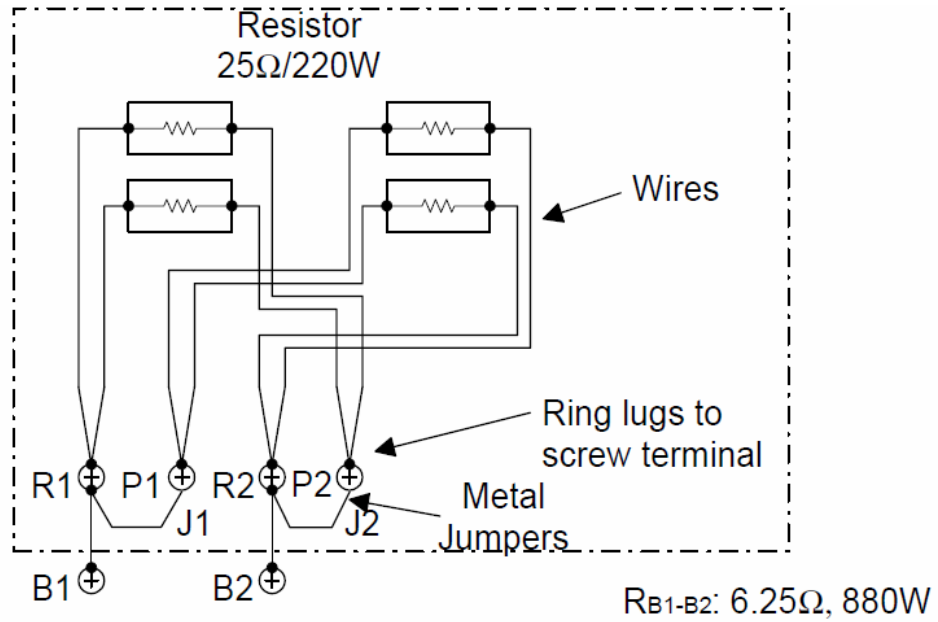

**Without Jumpers:**

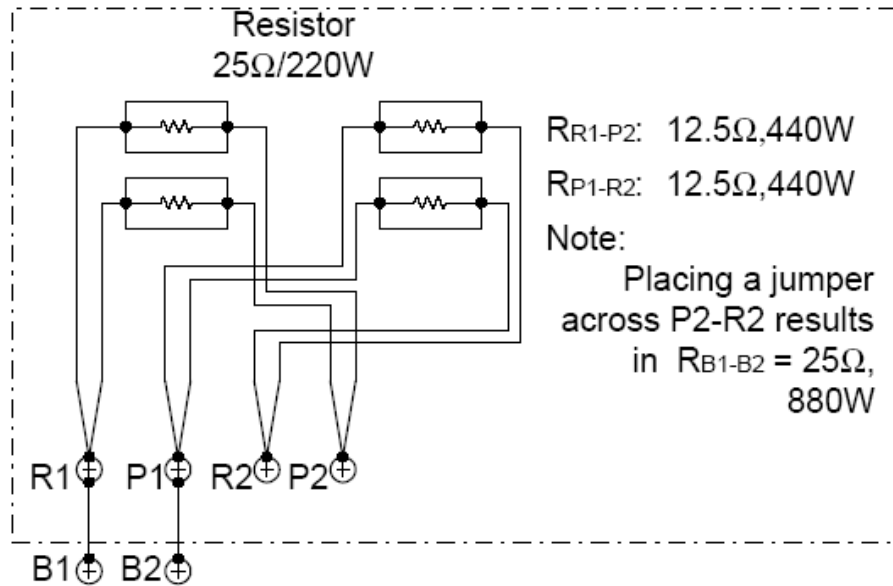

**JUSP-RA05 (shipped pre-wire for 3.12Ω, 1760W)**

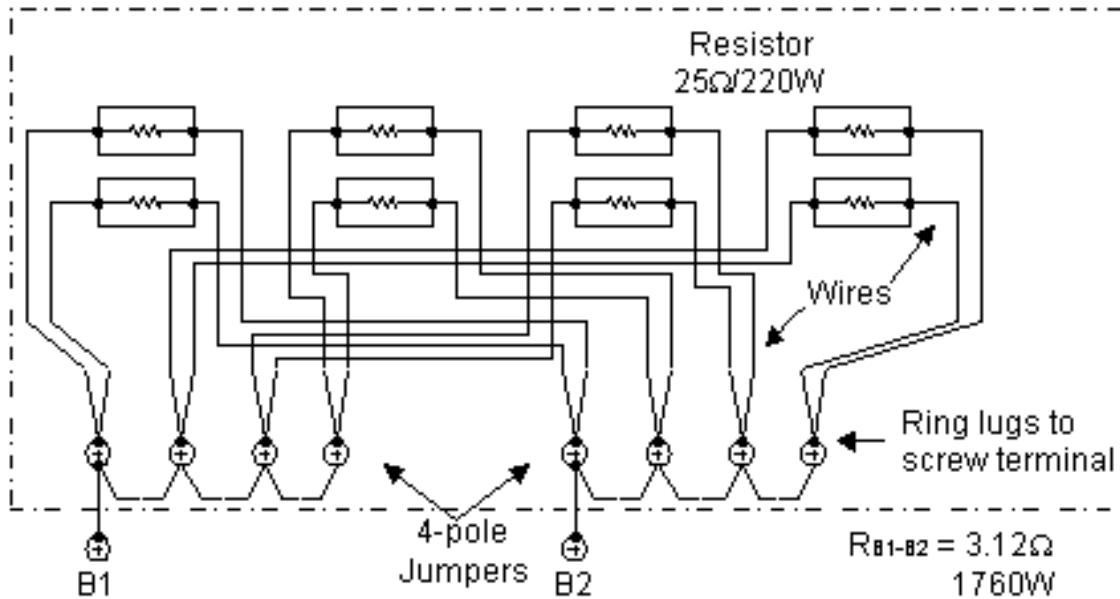

- Without the jumpers, this is essentially the same as wiring two JUSP-RA04 units.

## JUSP-RA18

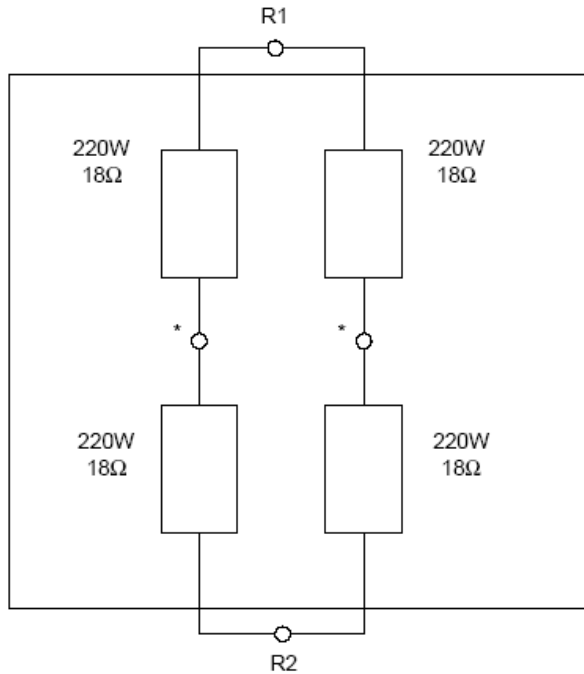

\*: These use terminal in parts hidden by the terminal block cover. These terminals should not be connected to from the outside.

- JUSP-RA18 is pre-wired for 18Ω, 880W

## JUSP-RA19

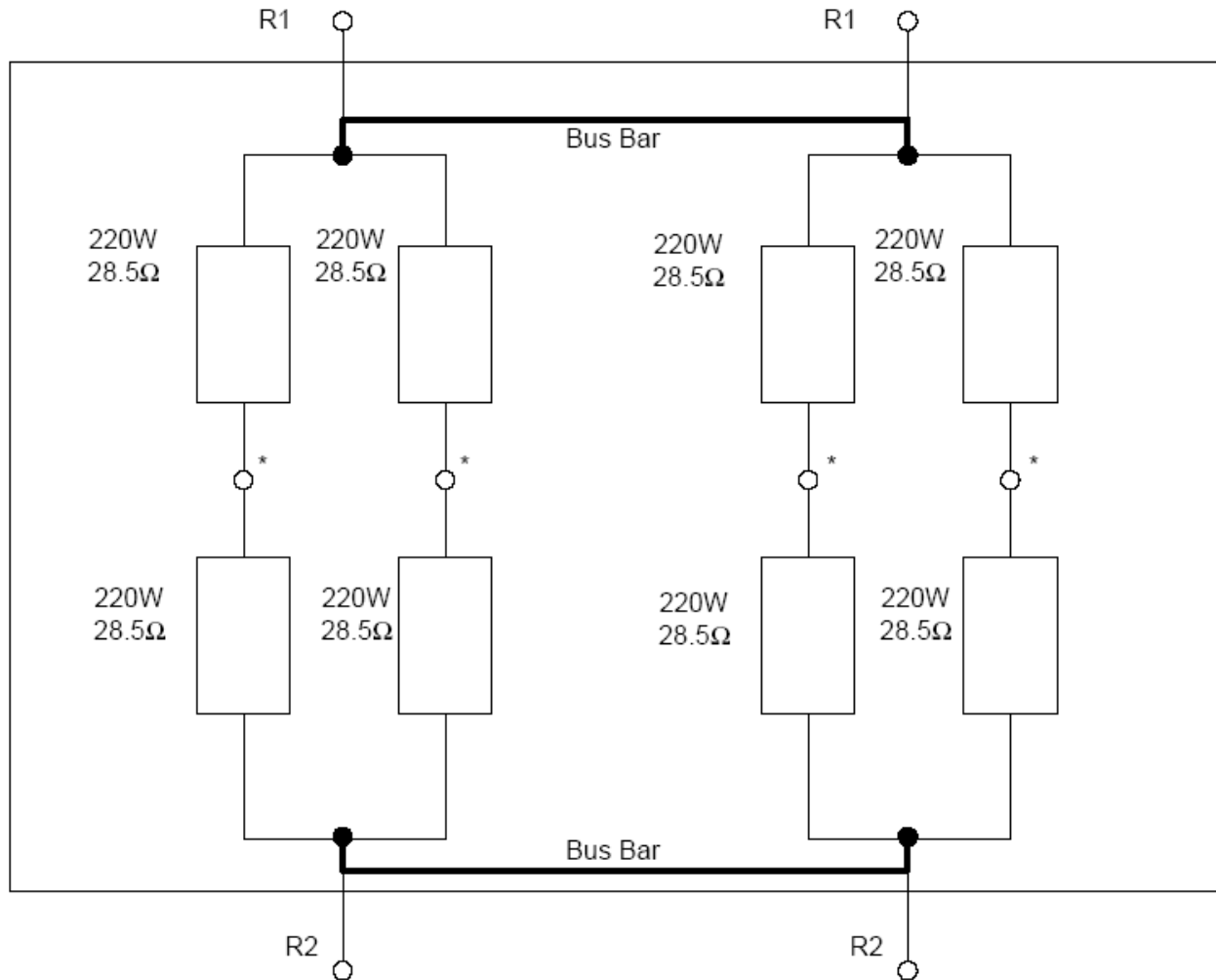

\*: These use terminal in parts hidden by the terminal block cover. These terminals should not be connected to from the outside.

- JUSP-RA19 is pre-wired for 14.25Ω, 1760W



**Table 1: External ReGen Resistors**

	Amplifier	Min Resistance (Ohm)	ReGen Resistor Resistance (Ohms)	Resistor Part Number (70W)	Resistor Part Number (90W)	Resistor Part Number (120W)	Resistor Part Number (200W)	Resistor Part Number (300W)					
100V	SGDV-R70F	40	50 +/- 5	RH120 50OHM K	RH150 50OHM K	RH220 50OHM K							
	SGDV-R90F	40	50 +/- 5										
	SGDV-2R1F	40	50 +/- 5										
	SGDV-2R8F	40	50 +/- 5										
200V	SGDV-R70A	40	50 +/- 5										
	SGDV-R90A	40	50 +/- 5										
	SGDV-1R6A	40	50 +/- 5										
	SGDV-2R8A	40	50 +/- 5										
	SGDV-3R8A	40	50 +/- 5										
	SGDV-5R5A	40	50 +/- 5										
	SGDV-7R6A	40	50 +/- 5										
	SGDV-120A	20	25 +/- 2.5						RH120 25OHM K	RH150 25OHM K	RH220 25OHM K		RH500 25OHM K
	SGDV-180A	12	15 +/- 1.5						RH120 15OHM K	RH150 15OHM K	RH220 15OHM K		RH500 15OHM K
	SGDV-200A	12	15 +/- 1.5										
	SGDV-330A	8	10 +/- 1	RH120 10OHM K	RH150 10OHM K	RH220 10OHM K	RH300C 10OHM K	RH300C 10OHM K					
SGDV-470A	5.8	7 +/- 0.7	RH120 7OHM K	RH150 7OHM K	RH220 7OHM K	RH300C 7OHM K							
SGDV-550A	2.9	4 +/- 0.4	RH120 4OHM K	RH150 4OHM K	RH220 4OHM K	RH300C 4OHM K							
SGDV-590A	2.9	4 +/- 0.4											
SGDV-780A	2.9	4 +/- 0.4											
400V	SGDV-1R9D	73	85 +/- 8.5	RH120 85OHM K	RH150 85OHM K	RH220 85OHM K							
	SGDV-3R5D	73	85 +/- 8.5										
	SGDV-5R4D	73	85 +/- 8.5										
	SGDV-8R4D	44	50 +/- 5	RH120 50OHM K	RH150 50OHM K	RH220 50OHM K							
	SGDV-120D	44	50 +/- 5										
	SGDV-170D	28	35 +/- 3.5	RH120 35OHM K	RH150 35OHM K	RH220 35OHM K							