

YASKAWA AC Drive GA500

Supplemental Technical Manual

Introduction

This supplemental technical manual describes the modified specifications with a GA500 software upgrade and corrections. Read this manual together with “ Installation & Primary Operation” (TOEP C710617 52) included with the product and the “ GA500 Technical Reference” (SIEP C710617 52) that you can download from our documentation website. Read and understand the safety information and precautions before you start to use the product.

Revised Contents and Applicable Drive Models

Item	Description	Model
1.	Setting range of <i>C6-02 [Carrier Frequency Selection]</i> when in AOLV/PM	GA500 Software version PRG: 01013 or later <1>
2.	Addition of Parameter Not Initialized when <i>A1-03 = 2220, 3330 [Initialize Parameters = 2-Wire Initialization, 3-Wire Initialization]</i>	
3.	Revised default setting of <i>o1-37 [LCD Backlight ON/OFF Selection]</i>	
4.	Revised default setting of <i>T1-13 [No-load voltage]</i>	
5.	Correction of Ferrule Terminal Sizes	All GA500 drives
6.	Correction of <i>H2-01 to H2-03</i> terminal MA/MB-MC, P1-C1, P2-C2 function selection	
7.	Correction of interlock circuit example	
8.	Corrections of the status of digital input/output terminals during Auto-Tuning	

<1> The software version is indicated on the nameplate affixed to the side of the product, and also can be viewed when you use monitor parameter *U1-25 [Software number]*.

1. Setting Range of *C6-02 [Carrier Frequency Selection]* when in AOLV/PM

The maximum carrier frequency is different when *A1-02 = 6 [Control Method Selection = PM Advanced Open Loop Vector]*.

- PRG: 01012 or earlier: 4.0 kHz (*C6-02 = 2*)
- PRG: 01013 or later: 12.0 kHz (*C6-02 = 6*)

2. Addition of Parameter Not Initialized when A1-03 = 2220, 3330 [Initialize Parameters = 2-Wire Initialization, 3-Wire Initialization]

Even when you set A1-03 = 2220, 3330 [Initialize Parameters = 2-Wire Initialization, 3-Wire Initialization] to initialize the drive, A1-12 [Bluetooth ID] is not initialized.

- PRG: 01012 or earlier: The setting value of A1-12 is initialized.
- PRG: 01013 or later: The setting value of A1-12 is not initialized.

3. Revised Default Setting of o1-37 [LCD Backlight ON/OFF Selection]

The default setting of o1-37 [LCD Backlight ON/OFF Selection] is different.

- PRG: 01012 or earlier: 0 [OFF]
- PRG: 01013 or later: 1 [ON]

4. Revised Default Setting of T1-13 [No-load voltage]

The default setting of T1-13 [No-load voltage] is different.

PRG	01012 or Earlier		01013 or Later	
Drive Model	B001 to B018 2001 to 2056 4001 to 4031	2070 to 2082 4038 to 4060	B001 to B006 2001 to 2008 4001 to 4004	B010 to B018 2010 to 2082 4005 to 4060
Default value of T1-13	$T1-03 \times 0.85$	$T1-03 \times 0.90$	$T1-03 \times 0.85$	$T1-03 \times 0.90$

5. Correction of Ferrule Terminal Sizes

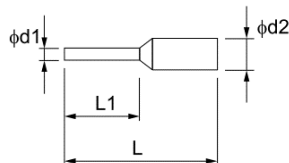

Wrong:

Wire Gauge mm ² (AWG)	Model	L (mm)	L1 (mm)	φ d1 (mm)	φ d2 (mm)
0.25 (24)	AI 0.25-8YE	12.5	8.0	0.8	2.0
0.34 (22)	AI 0.34-8TQ	12.5	8.0	0.8	2.0
0.5 (20)	AI 0.5-8 WH AI 0.5-8 OG	14.0	8.0	1.1	2.5

Correct:

Bold texts show additions and modifications.

Wire Gauge mm ² (AWG)	Model	L (mm)	L1 (mm)	φ d1 (mm)	φ d2 (mm)
0.25 (24)	AI 0.25-6 YE AI 0.25-6 BU	10.5	6.0	0.8	2.0
0.34 (22)	AI 0.34-6 TQ	10.5	6.0	0.8	2.0
0.5 (20)	AI 0.5-6 WH AI 0.5-6 OG	12.0	6.0	1.1	2.5
0.75 (18)	AI 0.75-6 GY AI 0.75-6 WH	12.0	6.0	1.3	2.8
1.0 (17)	AI 1-6 RD AI 1-6 YE	12.0	6.0	1.5	3.0

6. Correction of H2-01 to H2-03 Terminal MA/MB-MC, P1-C1, P2-C2 Function Selection

Wrong: p.634, SIEPC71061752B

Table 12.59 MFDO Terminals Default Function Settings

No.	Name	Default	Function
H2-01	Term MA/MB-MC Function Selection (Contact)	0	During Run
H2-02	Term P1-C1 Function Selection	1	Zero Speed
H2-03	Term P2-C2 Function Selection	2	Speed Agree 1

Correct:

Bold texts show additions and modifications.

Table 12.59 MFDO Terminals Default Function Settings

No.	Name	Default	Function
H2-01	Term MA/MB-MC Function Selection (Contact)	E	Fault
H2-02	Term P1-C1 Function Selection	0	During Run
H2-03	Term P2-C2 Function Selection	2	Speed Agree 1

7. Correction of Interlock Circuit Example

Wrong: p.92, SIEPC71061752B

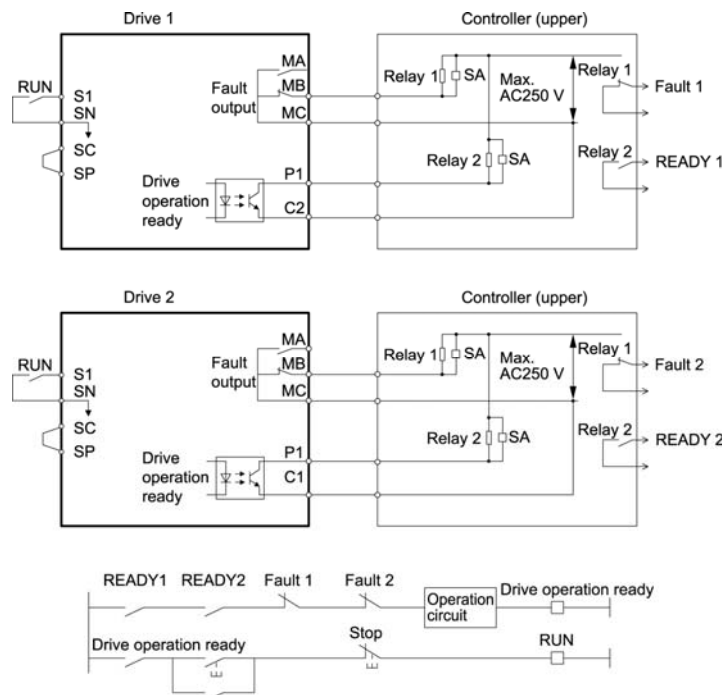

Figure 3.52 Interlock Circuit Example

Correct:

These are the modifications:

- Drive 1 Terminal C2 → Terminal C1
- Diagram of Photocoupler 1

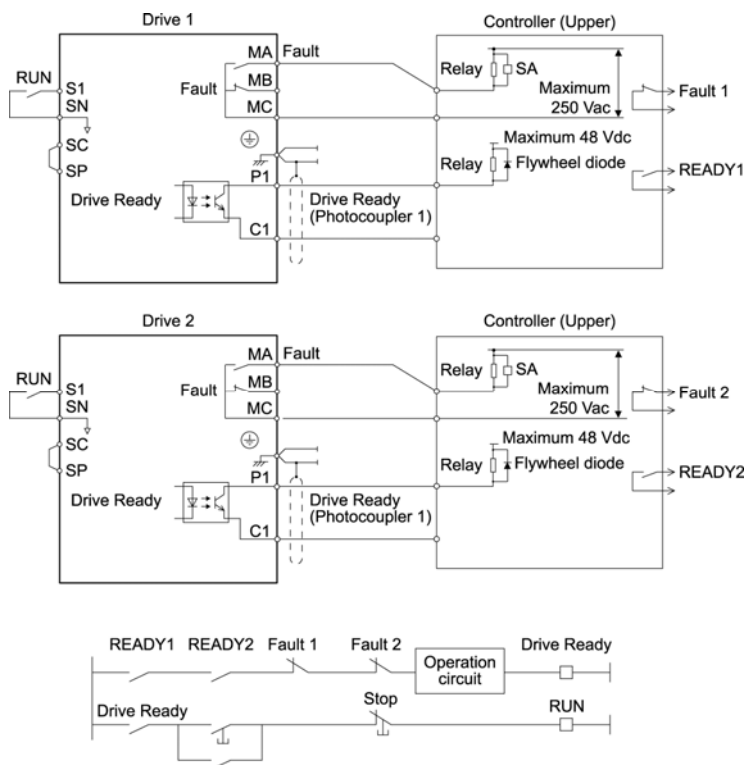

Figure 3.52 Interlock Circuit Example

8. Corrections of the Status of Digital Input/Output Terminals during Auto-Tuning

Wrong: p.137, SIEPC71061752B

Table 4.16 Status of Input/Output Terminals during Auto-Tuning

Auto-Tuning Type	Mode		Parameter	Multi-Function Input	Multi-Function Output
Induction Motor Auto-Tuning	Rotational	Rotational Auto-Tuning	T1-01 = 0	Disabled	Functions the same as during usual operation.
	Stationary	Stationary Auto-Tuning 1	T1-01 = 1	Disabled	Keeps the status at the start of Auto-Tuning.
		Line-to-Line Resistance	T1-01 = 2	Disabled	Keeps the status at the start of Auto-Tuning.
PM Motor Auto-Tuning	Rotational	PM Motor Code Selection	T2-01 = 4	Disabled	Functions the same as during usual operation.
	Stationary	Manual Entry w/ Motor Data Sheet	T2-01 = 0	Disabled	Disabled
		PM Stationary Auto-Tuning	T2-01 = 1	Disabled	Keeps the status at the start of Auto-Tuning.
		PM Stationary Auto-Tuning for Stator Resistance	T2-01 = 2	Disabled	Keeps the status at the start of Auto-Tuning.
		High Frequency Injection	T2-01 = 5	Disabled	Keeps the status at the start of Auto-Tuning.
EZ Tuning	Stationary	Motor Parameter Setting	T4-01 = 0	Disabled	Disabled
		Line-to-Line Resistance	T4-01 = 1	Disabled	Keeps the status at the start of Auto-Tuning.
ASR and Inertia Tuning	Rotational	Deceleration Rate Tuning	T3-00 = 2	Disabled	Functions the same as during usual operation.
		KEB Tuning	T3-00 = 3	Disabled	Functions the same as during usual operation.

Correct:

Underlined texts show modifications.

Table 4.16 Status of Input/Output Terminals during Auto-Tuning

Auto-Tuning Type	Mode		Parameter	Multi-Function Input	Multi-Function Output
Induction Motor Auto-Tuning	Rotational	Rotational Auto-Tuning	T1-01 = 0	Disabled	Functions the same as during usual operation.
	Stationary	Stationary Auto-Tuning 1	T1-01 = 1	Disabled	Keeps the status at the start of Auto-Tuning.
		Line-to-Line Resistance	T1-01 = 2	Disabled	Keeps the status at the start of Auto-Tuning.
PM Motor Auto-Tuning	Rotational	PM Motor Code Selection	T2-01 = 4	Disabled	Functions the same as during usual operation.
	Stationary	Manual Entry w/ Motor Data Sheet	T2-01 = 0	Disabled	<u>Keeps the status at the start of Auto-Tuning.</u>
		PM Stationary Auto-Tuning	T2-01 = 1	Disabled	Keeps the status at the start of Auto-Tuning.
		PM Stationary Auto-Tuning for Stator Resistance	T2-01 = 2	Disabled	Keeps the status at the start of Auto-Tuning.
		High Frequency Injection	T2-01 = 5	Disabled	Keeps the status at the start of Auto-Tuning.
EZ Tuning	Stationary	Motor Parameter Setting	T4-01 = 0	Disabled	<u>Keeps the status at the start of Auto-Tuning.</u>
		Line-to-Line Resistance	T4-01 = 1	Disabled	Keeps the status at the start of Auto-Tuning.
ASR and Inertia Tuning	Rotational	Deceleration Rate Tuning	T3-00 = 2	Disabled	Functions the same as during usual operation.
		KEB Tuning	T3-00 = 3	Disabled	Functions the same as during usual operation.