



Installation • Operation • Maintenance

*Controller Type
HCB 5, 9, 18*

*Technical Manual
TM 2205*

TABLE OF CONTENTS

Title	Page
General Description	1
Specifications	1
Controller Type and Model Identification	2
Modification Kits	2
Replacement Parts	3
Installation	4
Description of Controls	5
Adjustments	6
Start/Stop Instructions	7
Theory of Operation	8
Troubleshooting Charts	10
Modification Kit Installation	12
Schematic Modification	14
Instructions for Interconnecting Equipment	22

LIST OF ILLUSTRATIONS

Figure Number	Title	Page
1	Mod 7 Type HCB2 Controller with Optional Transformer	1
2	Controller Installation Dimensions	4
3	Location of Controls	5
4	Eddy Current Drive System	9
5	Modification PCB Location	12
6	Adjustment Knob Installation	13
7	Identification Plate Application	13
8	Application of Schematic Overlay (Typical)	14
9	HCB2, 5, 9 and 18 Controller Simplified Schematic Diagram (Sheet 1 of 3)	15
9	HCB2 Controller Simplified Schematic Diagram (Sheet 2 of 3)	16
9	HCB5, 9 and 18 Controller Schematic Simplified Diagram (Sheet 3 of 3)	17
10A	Interconnection Diagram — HCB2 with Integral Transformer	19
10B	Interconnection Diagram — HCB2 without Integral Transformer	21
10C	Interconnection Diagram — HCB5, 9 or 18	23
11	HCB Controller, Major Component Location	27

LIST OF TABLES

Table Number	Title	Page
1	Standard Modification Kits	2
2	Spare Parts List	3
3	Function of Controls	5
4	Equipment Identification	24
5	Interconnection Table	25

"GROUNDING NOTE"

**WHEN GROUNDING OF THE CONTROLLER, OPERATORS CONTROL STATION
AND/OR CLUTCH VIA GROUND STUDS LOCATED WITHIN THE CONTROLLER;
GROUND KIT PART NUMBER 46S02547-0010 MUST BE USED. THIS KIT IS
AVAILABLE THRU YOUR LOCAL LOUIS ALLIS DISTRICT OFFICE.**

GENERAL DESCRIPTION

The MOD 7 Clutch Brake Controller (see Figure 1) converts single phase AC power to controlled DC power. This controlled DC power is applied to the field coil of a magnetic clutch or the field coil of a brake as required to control the drive output speed. The Controller is capable of controlling the output speed of both air and liquid cooled eddy current drives.

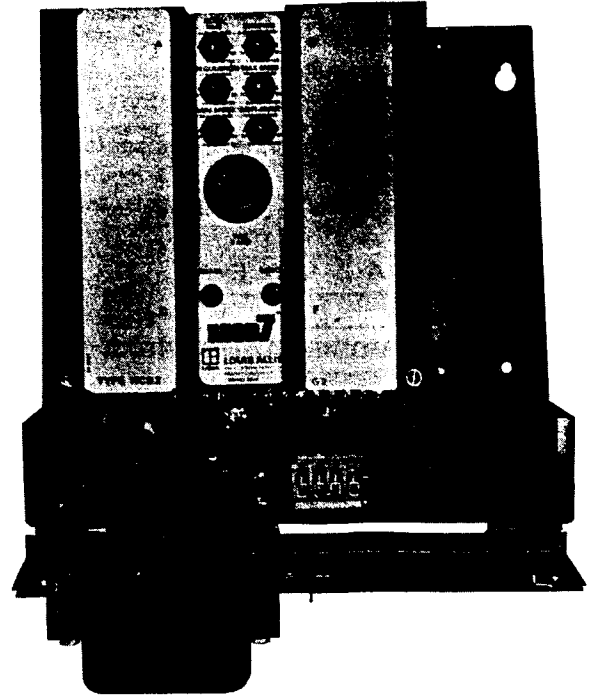

Figure 1. MOD 7 Type HCB2 Controller with Optional Transformer

SPECIFICATIONS

	HCB2	HCB2 with Integral Xfmr	HCB5	HCB9	HCB18
Input Voltage	230 VAC, center tapped, +10%, -5%	230/460 VAC, +10%, - 5%	230 VAC, center tapped, +10%, -5%	230 VAC, center tapped, +10%, -5%	230 VAC, center tapped, +10%, -5%
Input Current	3 Amps	3 Amps	6 Amps	12 Amps	22 Amps
Rating	220W	220W	500W	900W	1800W
AC Frequency	50/60 Hz	50/60 Hz	50/60 Hz	50/60 Hz	50/60 Hz
Clutch Output	0-90 VDC, 0-2 4A	0-90 VDC, 0-2 4A	0-90 VDC, 0-5 5A	0-90 VDC, 0-10A	0-90 VDC, 0-20A
Brake Output	0-90 VDC, 0-2 4A	0-90 VDC, 0-2 4A	0-90 VDC, 0-5 5A	0-90 VDC, 0-10A	0-90 VDC, 0-20A
Speed Regulation	0.5% of top speed	0.5% of top speed	0.5% of top speed	0.5% of top speed	0.5% of top speed
Drift	0.5% of top speed	0.5% of top speed	0.5% of top speed	0.5% of top speed	0.5% of top speed
Min Regulated Speed	50 RPM	50 RPM	50 RPM	50 RPM	50 RPM
Tachometer voltage (at rated speed)	17-106 VAC or 19.2-150 VDC	17-106 VAC or 19.2-150 VDC	17-106 VAC or 19.2-150 VDC	17-106 VAC or 19.2-150 VDC	17-106 VAC or 19.2-150 VDC
Ambient Temp	0-45°C	0-45°C	0-45°C	0-45°C	0-45°C
Size	11 62" x 12 25" x 6 88"	15 37" x 12 25" x 6 88"	11 62" x 14 00" x 8 50"	11 62" x 14 00" x 8 50"	11 62" x 14 00" x 8 50"
Weight	10 lb	24-1/2 lb	13 lb	13 lb	13 lb
Fuse 1F	Buss ABC 3 Amps	Buss ABC 3 Amps	Buss ABC 3 Amps	Buss ABC 3 Amps	Buss ABC 3 Amps
Fuse 2F and 3F	Buss ABC 3 Amps	Buss ABC 3 Amps	Buss ABC 6 Amps	Buss ABC 8 Amps	Buss ABC 15 Amps

CONTROLLER TYPE AND MODEL IDENTIFICATION

Two methods have been established for identifying the Controller with various modifications.

METHOD 1

This method consists of a Model Type number followed by seven digits. The Model Type number is located on the Regulator (black) cover. The first six digits correspond to the

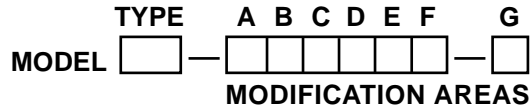

six modification areas (A through F) on the Regulator PCB, and the seventh digit (G) refers to enclosure and transformer types. The seven digits may be obtained from the identification plates on the Regulator cover after all

Modification Kits are installed. Insert the Modification Kit number into the block corresponding to each modification area. If no Modification Kit is installed for a given area, insert the number zero in that block

METHOD 2

If the Controller is custom designed, a serial number will be assigned at the factory and will be located on the Controller nameplate. Record the serial number in the space below.

SERIAL NUMBER _____

DATE INSTALLED _____

MODIFICATION KITS

TABLE 1. STANDARD MODIFICATION KITS

MOD AREA	DESCRIPTION	PART NUMBER
A	1 Linear Accel/Decel	A1K
	2 Linear Accel/Decel with S-Curve	A2K
	3 Not Available	
	4 Not Available	
	5 Clutch Current	A5K
	6 Clutch Current/Speed	A6K
	7 Not Available	
	8 Log Accel/Decel	A8K
B	1 Voltage Follower	B1K
	2 Current Follower	B2K
	3 Voltage Follower with Man/Auto	B3K
	4 Current Follower with Man/Auto	B4K
	5 Master Reference	B5K
C	1 Jog, Separately Adjustable	C1K
	2 Thread, Separately Adjustable	C2K
	3 Jog and Thread, Separately Adjustable	C3K
	4 Thread (External Pot)	C4K
D	1 Controlled Stop	D1K
	2 Adjustable Trip	D2K
	3 Differential Trip	D3K
E	1 Adjustable Breakaway	E1K
	2 Torque Limit (Clutch Current)	E2K
	3 Torque Limit (Motor Current)	E3K

Modification Kits for the MOD 7 eddy current drives are listed in Table 1. These Modification Kits enable modification of the basic Controller for a variety of control and operational functions. Contact the nearest Louis Allis District Office for ordering information for these Modification Kits.

REPLACEMENT PARTS

Spare parts for the standard HCB Controllers are listed in Table 2. Custom designed orders may require special parts other than those listed in the table. When ordering spare

parts for custom designed orders, specify the model number and serial number stamped on the Controller nameplate. Contact the nearest Louis Allis District Office for parts ordering information.

Table 2. SPARE PARTS LIST

DESCRIPTION	SYMBOL	PART NUMBER	RECOMMENDED STOCK QUANTITY BASED ON NUMBER OF IDENTICAL DRIVES OR ASSEMBLIES			
			1 - 4	5 - 9	10 - 25	26 or More
Fuse, 3 Amps	1F	05P00017-0138	5	10	15	20
Fuse, 3 Amps (HCB2 Only)	2F, 3F	05P00017-0138	5	10	15	20
Fuse, 6 Amps (HCB5 Only)	2F, 3F	05P00017-0133	5	10	15	20
Fuse, 8 Amps (HCB9 Only)	2F, 3F	05P00017-0135	5	10	15	20
Fuse, 15 Amps (HCB18 Only)	2F, 3F	05P00017-0119	5	10	15	20
AC Relay	1CR	05P00036-0287	0	1	2	2
Power Relay (HCB5, 9 & 18)	1CRA	05P00036-0284	0	1	2	2
Regulator PCB		46S02355-0011	1	2	3	4
Bridge PCB (HCB2 Only)		46S02063-0010	1	2	3	4
Power Circuit PCB (HCB5, 9 & 18)		46S02073-0010	1	2	3	4
SCR Power Module (HCB5 & 9)	1 EA	05P00050-0240	1	2	3	4
SCR Power Module (HCB18 Only)	1 EA	05P00050-0241	1	2	3	4
Modification PCB's:						
Linear Accel/Decel	A1	46S02042-0020	1	1	2	2
Linear Accel/Decel w/S-Curve	A2	46S02042-0010	1	1	2	2
Clutch Current	A5	46S02064-0050	1	1	2	2
Clutch Current/Speed	A6	46S02050-0031	1	1	2	2
Log Accel	A8	46S02085-0010	1	1	2	2
Voltage Follower	B1	46S02044-0020	1	1	2	2
Current Follower	B2	46S02043-0020	1	1	2	2
Voltage Follower M/A	B3	46S02044-0010	1	1	2	2
Current Follower M/A	B4	46S02043-0010	1	1	2	2
Master Reference	B5	46S02052-0010	1	1	2	2
Jog	C1	46S02049-0010	1	1	2	2
Thread	C2	46S02049-0020	1	1	2	2
Jog/Thread	C3	46S02049-0030	1	1	2	2
Thread (External Pot)	C4	46S2138-0010	1	1	2	2
Controlled Stop	D1	46S02047-0010	1	1	2	2
Adjustable Trip	D2	46S02047-0020	1	1	2	2
Differential Trip	D3	46S02047-0030	1	1	2	2
Adjustable Breakaway	E1	46S02046-0010	1	1	2	2
Torque Limit Clutch I	E2	46S02045-0010	1	1	2	2
Torque Limit Motor I	E3	46S2151-0020	1	1	2	2
Connector Cord, 3.5 in.		05P00034-0232	0	0	0	0
Connector Cord, 10 in.		05P00034-0234	0	0	0	0
Hold Down Clip		05P00001-0126	0	0	0	0
Standoff		05P00065-0055	0	0	0	0
Extracting Tool		05P00065-0058	0	0	0	0
Potentiometer Knob		43T01232-0000	0	0	0	0
Jumper Plug	1CONN	46S02064-0010	0	0	0	0
Jumper Plug	2CONN	46S02064-0020	0	0	0	0
Jumper Plug	3CONN	46S02064-0030	0	0	0	0
Jumper Plug	6CONN	46S02064-0060	0	0	0	0

INSTALLATION

MECHANICAL

Mounting dimensions recommended for installation are given in Figure 2. The Controller is designed for wall mounting, however, exact positioning is not critical.

ELECTRICAL

The electrical interconnection is shown on the last pages of this manual. The diagrams and table include interconnection with Louis Allis supplied equipment as well as user supplied equipment. If Modification Kits have been included as part of this unit, they should be installed according to the instructions contained within this manual and within the Modification Kit before power is applied to the Controller.

Note

Insure that continuity plugs are properly inserted for unused Modification Areas. Area E does not require a continuity plug.

SYSTEM APPLICATION

When the system application calls for two or more MOD 7 Controllers to operate from a single reference source, such as a follower or master reference, isolation transformers are required on each Controller. The use of isolation transformers enables the system to operate with a single reference common.

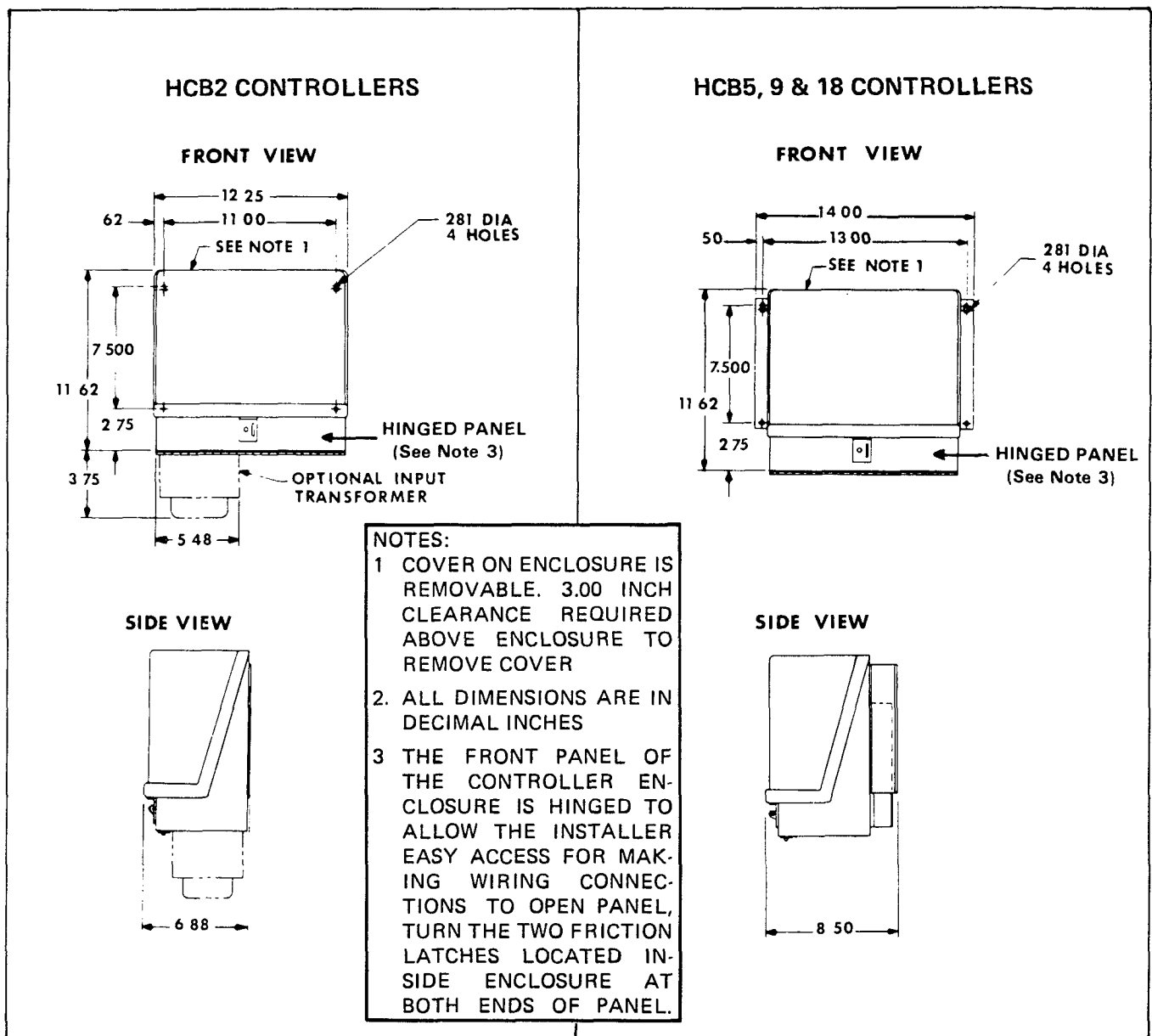

Figure 2 Controller Installation Dimensions

DESCRIPTION OF CONTROLS

Controls are provided on and under the Regulator cover to enable calibration of drive performance

These controls are illustrated and their function described in the figure and table below.

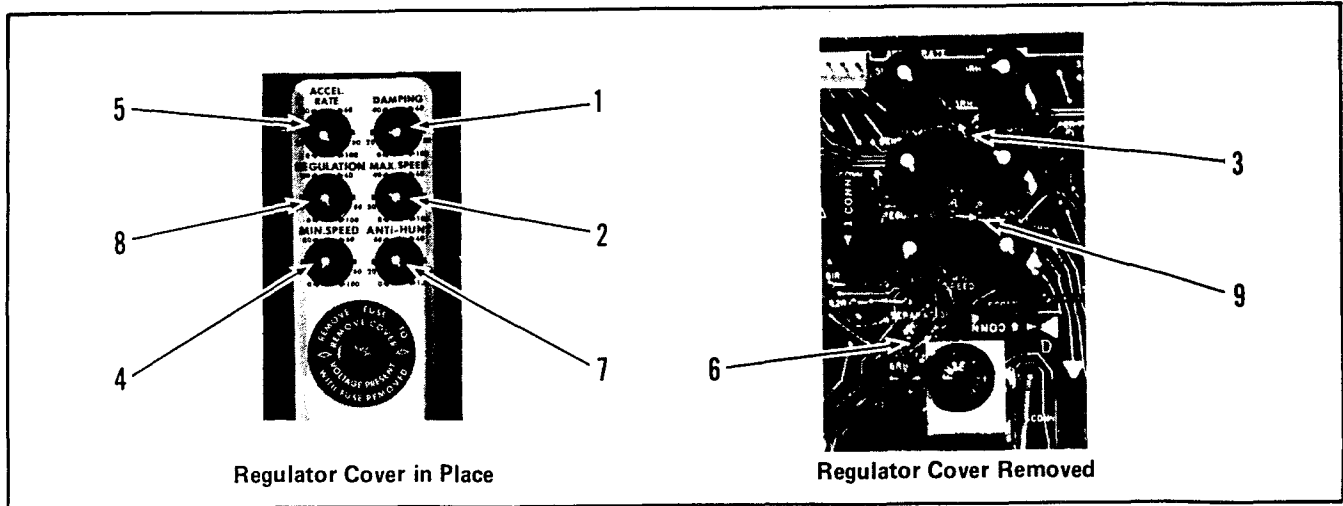

Figure 3. Location of Controls

Table 3. Function of Controls

REF. NO.	CONTROL NAME	FUNCTION
1	DAMPING (1RH)	Stabilizes drive speed with various loads Provides tachometer rate feedback to control speed overshoot Turning knob clockwise provides more damping and reduces speed overshoot.
2	MAX SPEED (2RH)	Calibrates tachometer to drive SPEED CONTROL adjustment Turning knob clockwise increases maximum speed
3	TENSION SENSITIVITY (3RH) *	Adjusts the steady state gain at the Controller when in the Tension or Direct Torque Control mode Calibrates the tension control reference with the actual eddy current machine used Turning control clockwise increases machine torque output for a given input signal
4	MIN SPEED (4RH)	Sets minimum running speed of the drive when SPEED CONTROL is set at zero Turning knob clockwise increases the minimum speed
5	ACCEL RATE (5RH)	Adjusts the acceleration rate of the drive reference Turning knob clockwise increases the rate and reduces acceleration time
6	SEPARATION (6RH) *	Adjusts Controller so that major system disturbances do not cause clutch and brake to be on simultaneously. Turning control clockwise increases separation of clutch and brake action
7	ANTI-HUNT (7RH)	Stabilizes the drive Controller with the actual eddy current machine used. Turning knob clockwise increases the Controller stability.
8	REGULATION (8RH)	Adjusts the steady state gain of the Controller when in the Speed Control mode. Turning knob clockwise increases gain and increases the regulating ability of the drive.
9	TORQ COMP (9RH) *	Adjusts the drive Controller to compensate for wide variations in the torque response of various eddy current clutches Turning control clockwise slows down the Controller ANTI-HUNT circuit to match the torque-time response of slow-acting eddy current machines.
Fig 12 Item 15	ADJ BRAKE (10 RH) *	Adjusts the amount of current applied to the brake coil while the drive is stopped, from 0 to 100% of rated brake output Turning clockwise increases current.,

* Make adjustment by inserting tip of screwdriver blade in slot of potentiometer wheel and turning

ADJUSTMENTS

INITIAL SWITCH SETTINGS

If the tachometer voltage expected at maximum drive speed is known or can be calculated, selector switches 1SS and 2SS should be preset as follows:

If the tachometer voltage is not known, begin the adjustment procedure with both 1SS and 2SS closed

TACHOMETER VOLTAGE AT MAX SPEED		SELECTOR SWITCH	
		1SS	2SS
VAC	VDC		
17-40	19.2-48	CLOSED	CLOSED
36-82	40-98	OPEN	CLOSED
54-106	60-150	OPEN	OPEN

ADJUSTMENTS-ENERGIZED DRIVE

Before energizing the drive, set controls as follows

1. DAMPING (1RH) - Set at 20%.
2. MAX SPEED (2RH) - Set at zero.
3. TENSION SENSITIVITY (3RH) - Set at zero.
4. MIN SPEED (4RH) - Set at zero.
5. ACCEL RATE (5RH) - Set at 60%.
6. SEPARATION (6RH) - Set at 80%.
7. ANTI-HUNT (7RH) - Set at 80%.
8. REGULATION (8RH) - Set at 80%.
9. TORQ COMP. (9RH) - Set at zero. (See Note.)
10. ADJ BRAKE (10 RH) - Set at Zero.
11. SPEED CONTROL (located on Operator Control Station) - Set at zero.

- A. Start AC motor and apply power to Controller
- B. Press RUN pushbutton
- C. Slowly turn SPEED CONTROL fully clockwise and observe drive speed increase
- D. With SPEED CONTROL fully clockwise, turn MAX SPEED potentiometer clockwise until desired maximum operating speed is reached. Do not set MAX SPEED potentiometer to a setting which will allow a clutch speed higher than that indicated on nameplate

NOTE: CLUTCH OUTPUT STABILITY

Some eddy current clutches have a slow buildup and decay of torque with field current changes. These machines are typically of older design, large in horsepower capacity and are likely to be liquid cooled. Normal setting of the ANTI-HUNT and DAMPING adjustments may not give adequate drive performance or stability. If the drive hesitates or oscillates during rapid acceleration or is particularly difficult to stabilize, turn the TORQ COMP adjustment to optimize performance, and readjust ANTI-HUNT as described in Step G. A 50% setting of TORQ COMP will improve operation with most liquid cooled machines.

Operation of ANTI-HUNT, DAMPING and TORQ COMP adjustments interact somewhat in terms of drive stability. It is possible to overcompensate with these adjustments, resulting in poor dynamic performance. Best results will be obtained when the adjustment settings are at the minimum level required to meet stability criteria.

NOTE

If the desired maximum speed cannot be obtained, in Step D, stop the drive, turn off power to the Controller and open 1SS. Restore Controller power and repeat the MAX SPEED adjustment procedure. If the desired maximum speed still cannot be reached, again stop the drive, turn off Controller power and open 2SS. Again restore Controller power and repeat the MAX SPEED adjustment procedure. If the desired maximum speed cannot be reached with both 1SS and 2SS open, either the drive is overloaded or the tachometer voltage is too high for the application and must be reduced externally.

- E. Turn SPEED CONTROL fully counterclockwise and observe drive speed decrease
- F. Turn MIN SPEED potentiometer clockwise until desired minimum operating speed is reached. If the desired minimum speed is zero, set this adjustment as high as possible, i.e. just below the point where

the drive will begin to rotate. Note that the friction load placed on the machine by other connected equipment must be great enough to prevent shaft rotation with the normal transmitted torque through the eddy current clutch produced by air or liquid cooling.

- G Turn off power to the Controller and connect a DC voltmeter to tachometer output terminals 1 (+) and 2 of the Controller. With power applied, restart the drive and set SPEED CONTROL to 50%. Slowly reduce the ANTI-HUNT adjustment until the drive speed becomes erratic and "hunts". Slowly increase ANTI-HUNT until the drive is stable again. No further adjustment of ANTI-HUNT should be necessary. (See CLUTCH OUTPUT STABILITY Note.)
- H Turn ACCEL RATE to maximum. Quickly set SPEED CONTROL to a new position and observe drive speed performance with the tachometer voltmeter connected in Step G. Adjust DAMPING as required to obtain the fastest new speed settling time with a minimum of speed overshoot. Turn off power to Controller and remove tachometer voltmeter. (See CLUTCH OUTPUT STABILITY Note.)
- I Turn ACCEL RATE potentiometer counterclockwise to 0%. Reapply power to Controller.
- J Turn SPEED CONTROL fully clockwise and start and stop drive several times while observing acceleration rate. Adjust ACCEL RATE potentiometer to give desired acceleration rate.
- K. Turn SPEED CONTROL so that drive is running at any speed above 50% rated speed and is not loaded by external machinery. Adjust SEPARATION potentiometer so that clutch and brake indicator lamps are just at the point of being on simultaneously but a bright glow is not visible in both lamps.

CAUTION

Operation of equipment with the SEPARATION potentiometer fully counterclockwise can cause the clutch and brake to be energized simultaneously and can cause overheating of the AC motor. If both clutch and brake indicator lamps are simultaneously illuminated, increase SEPARATION potentiometer setting.

- L. When equipment conditions permit, adjust REGULATION to achieve the required speed regulation ability under actual machine load operating conditions. Increasing the REGULATION setting may require slight readjustment of ANTI-HUNT- for optimum performance.
- M. When auxiliary equipment is connected that requires direct torque control, refer to the instructions furnished with that equipment for setting the TENSION SENSITIVITY adjustment.
- N. Press STOP pushbutton. With drive STOPPED, turn ADJ BRAKE clockwise to obtain desired brake (holding) action.

START/STOP INSTRUCTIONS

After installation and adjustments have been completed, the drive can be started and stopped for normal operation in the following manner:

TO START DRIVE

- 1 Start AC motor and apply power to Controller
- 2 Press RUN pushbutton
- 3 Advance SPEED CONTROL to desired drive speed

TO STOP DRIVE

- 1 Press STOP pushbutton
- 2 Stop AC motor

THEORY OF OPERATION

DRIVE OPERATION

A typical eddy current clutch brake drive system (Figure 4) consists of a MOD 7 Clutch Brake Controller, an AC motor, an eddy current clutch, a brake and a tachometer generator. Torque is transmitted from the AC motor to the load when the clutch field coil is excited by DC current from the Controller. Braking torque is applied to the load when the brake field coil is excited. The Controller supplies DC excitation to the clutch field coil or to the brake field coil to maintain desired speed as monitored by the tachometer generator

CONTROLLER OPERATION

Figure 9 is a simplified schematic diagram for the HCB2, 5, 9 and 18 Controllers. Sheet 1 of the diagram illustrates the Regulator PCB and is identical for all four Controller ratings. Sheet 2 illustrates the input fusing and power circuitry for the HCB2 Controller; sheet 3 shows the input fusing and power circuitry for the HCB5, 9 and 18. When referring to Figure 9, be sure to select the correct sheet for the Controller rating.

The external wiring installed by the user for typical operator controls and typical clutch and brake field coils is shown as dashed lines on sheet 1 of the diagram. Also shown are the connection terminals for tachometer generators. The areas for optional plug-in modifications are enclosed by dashed lines. When modifications have been installed, the appropriate circuitry will be shown within the designated area. When these modifications are to be installed by the user, refer to page 14 for schematic diagram modification instructions.

When the drive is stopped with power applied to the Controller, current (set by ADJ BRAKE 10 RH) is applied to the brake coil to brake (hold) the drive.

CAUTION

PROLONGED EXCITATION OF EDDY-CURRENT BRAKES AT ZERO SPEED MAY CAUSE EXCESSIVE HEATING AND COIL INSULATION DAMAGE. DEPRESSING THE CONTROLLER "STOP" BUTTON CAUSES EXCITATION TO BE APPLIED TO THE BRAKE. REMOVE INPUT POWER TO THE CONTROLLER TO REMOVE EXCITATION TO THE EDDY-CURRENT BRAKE.

A reference signal (from the SPEED CONTROL) proportional to the desired speed is applied to the Acceleration Control via modification areas C, D and A. The Acceleration Control limits the rate of increase in drive speed by controlling the rate of rise of the Reference signal. The

output of the Acceleration Control is applied as a reference to the Error Amplifier (1MC and associated components) via modification areas A and B. A tachometer speed feedback signal is also applied to the Error Amplifier via modification area A. Any difference between the speed reference and feedback signals is amplified and used as a power command signal to the Clutch and Brake Firing Phase Control circuits. These circuits regulate the timing of SCR triggering with respect to the AC power line and thereby control the magnitude of the rectified power applied to the eddy current clutch and brake fields. When the tachometer measured speed is less than the set reference speed, the amplified error signal drives the Clutch Firing Phase Control "on," causing more power to be applied to the clutch field so that the speed will increase. When the measured speed is greater than the reference speed, the amplified error signal reduces power to the clutch coil and, if the error is large enough, drives the Brake Firing Phase Control "on," causing power to be applied to the brake field so that the speed will decrease. When the measured speed is equal to the set reference speed no further action takes place. The SEPARATION potentiometer provides a bias to turn off both Clutch and Brake Firing Phase Control circuits so that minor periodic system disturbances will not cause both the clutch and brake to be energized at the same time.

A signal proportional to the net current flow in the clutch and brake field coils is developed across resistors in the power circuit as shown on sheet 2 or 3 of Figure 9. This signal is amplified and used to stabilize the Controller via the ANTI-HUNT adjustment and associated components. In the Speed Regulating or Tension Regulating operating modes that signal is also used to control the gain or regulating ability of the Error Amplifier via the REGULATION or TENSION SENSITIVITY ADJUSTMENTS, respectively.

Relay 1CR (and, on HCB5, 9 and 18 Controllers, auxiliary relay 1CRA) is used in conjunction with operator controls as a RUN relay. In the STOP condition, relay contacts deenergize the clutch circuit. The Phase Back Control circuit, also operated by relay 1CR, provides a coordinated startup and shutdown of the Error Amplifier, Clutch and Brake Firing Phase Control circuits, and Acceleration Control circuit for smooth starting.

An interlocking contact or switch may be wired between terminals 10 and 11 on the main terminal strip as shown on sheet 1 of the schematic diagram. The purpose of this interlock is to prevent drive operation when unsafe or damaging circumstances exist such as open machine guards, machine overtemperature, low liquid coolant pressure, etc. If this feature is not used, leave the jumper wire in place between terminals 10 and 11 for proper operation of the Controller.

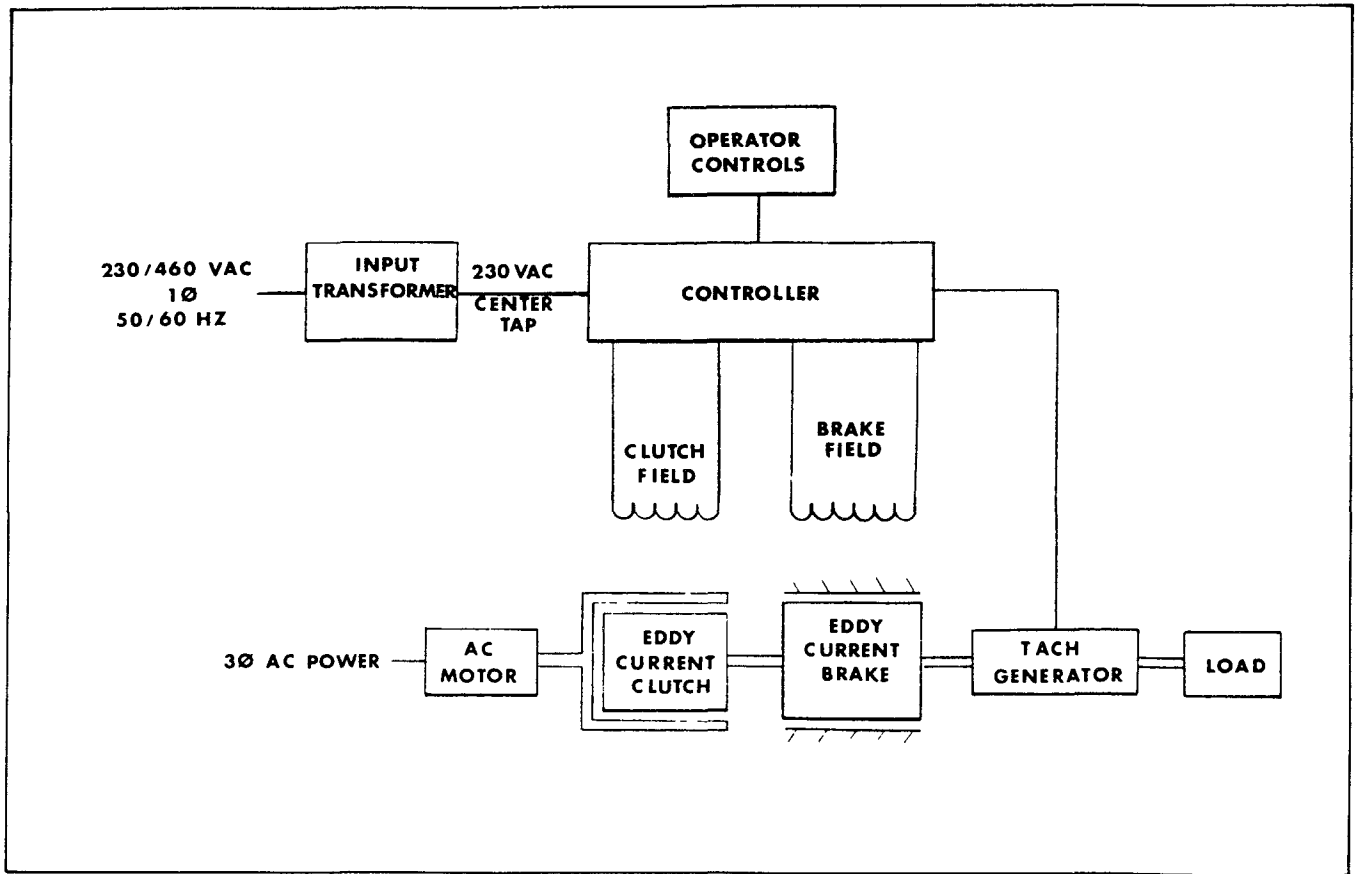
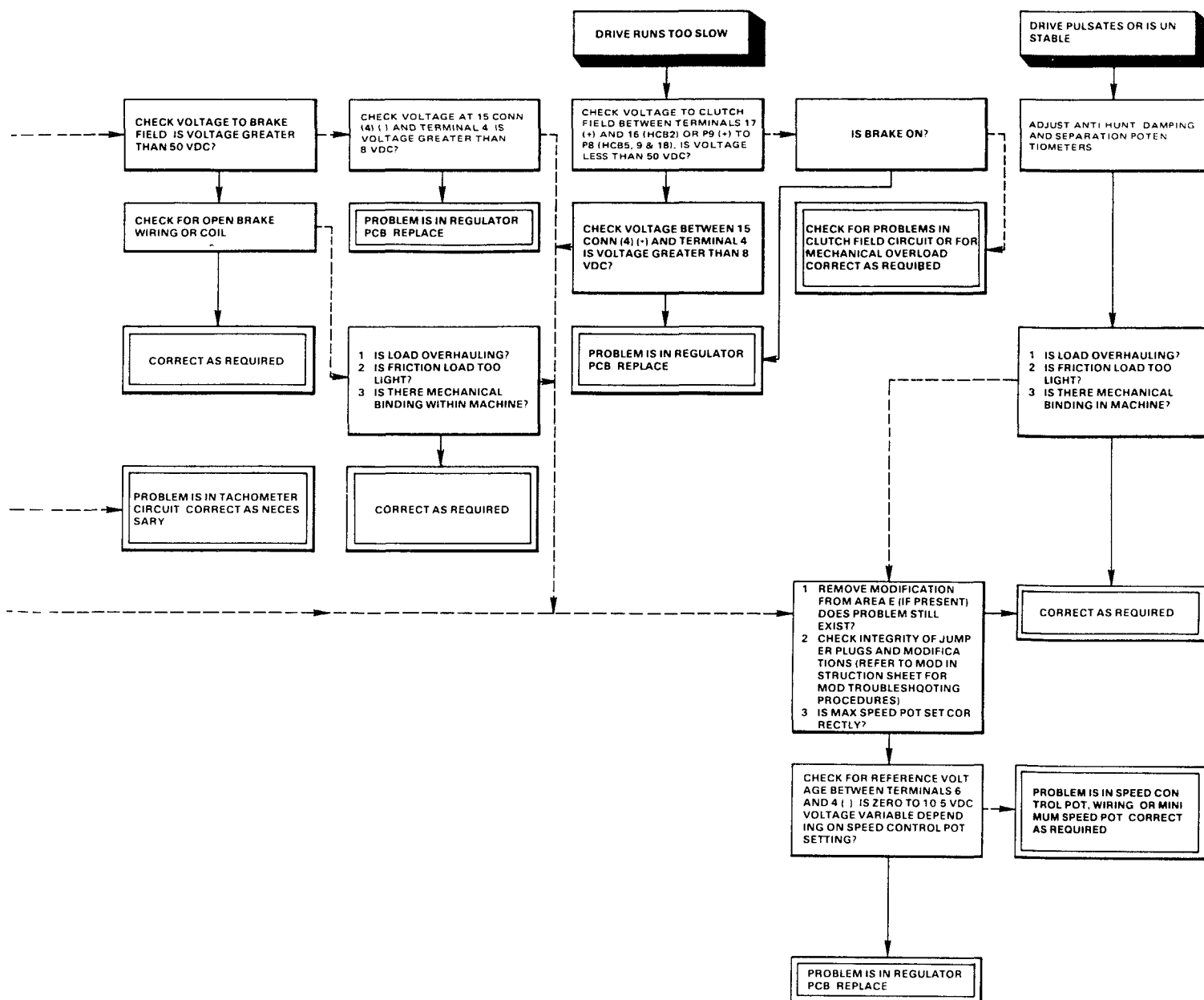
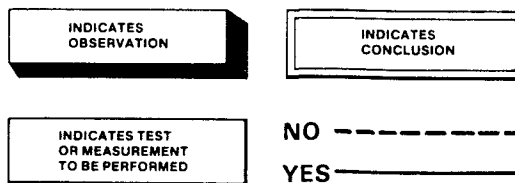

Figure 4 Eddy Current Drive System



LEGEND

The legend at right defines the types of condition blocks and connecting lines used in these charts



MODIFICATION KIT INSTALLATION

WARNING

Do not install Modification Kit while power is applied to Controller

A. MODIFICATION PCB INSTALLATION

- 1 Locate modification area on Regulator PCB as illustrated in Figure 5
- 2 Remove continuity plug from modification area on the Regulator PCB. This plug may be kept for possible future use
- 3 Install the three standoffs into the holes in the Regulator PCB. Standoffs will snap into place.

Note

Standoffs are designed for permanent mounting in the Regulator PCB. Do not attempt to remove standoffs after they are installed.

- 4 Insert the ribbon cable connector into the receptacle on the Regulator PCB. Insure that the polarizing

marks on the mating connectors are matched. Then curve the other end of the ribbon connector to the front of the modification PCB and insert the connector into the receptacle on the modification PCB, again matching polarizing marks on the mating connectors.

Note

When making connections, insure that no connector pins are bent and that all pins are properly inserted into receptacle.

5. Align a hold down clip over each connector and press gently until locked in place.
6. Align the holes in the modification PCB with the standoffs and gently press the modification PCB until it snaps into position.

Note

After modification PCB is installed, check that ribbon cable connections are secure.

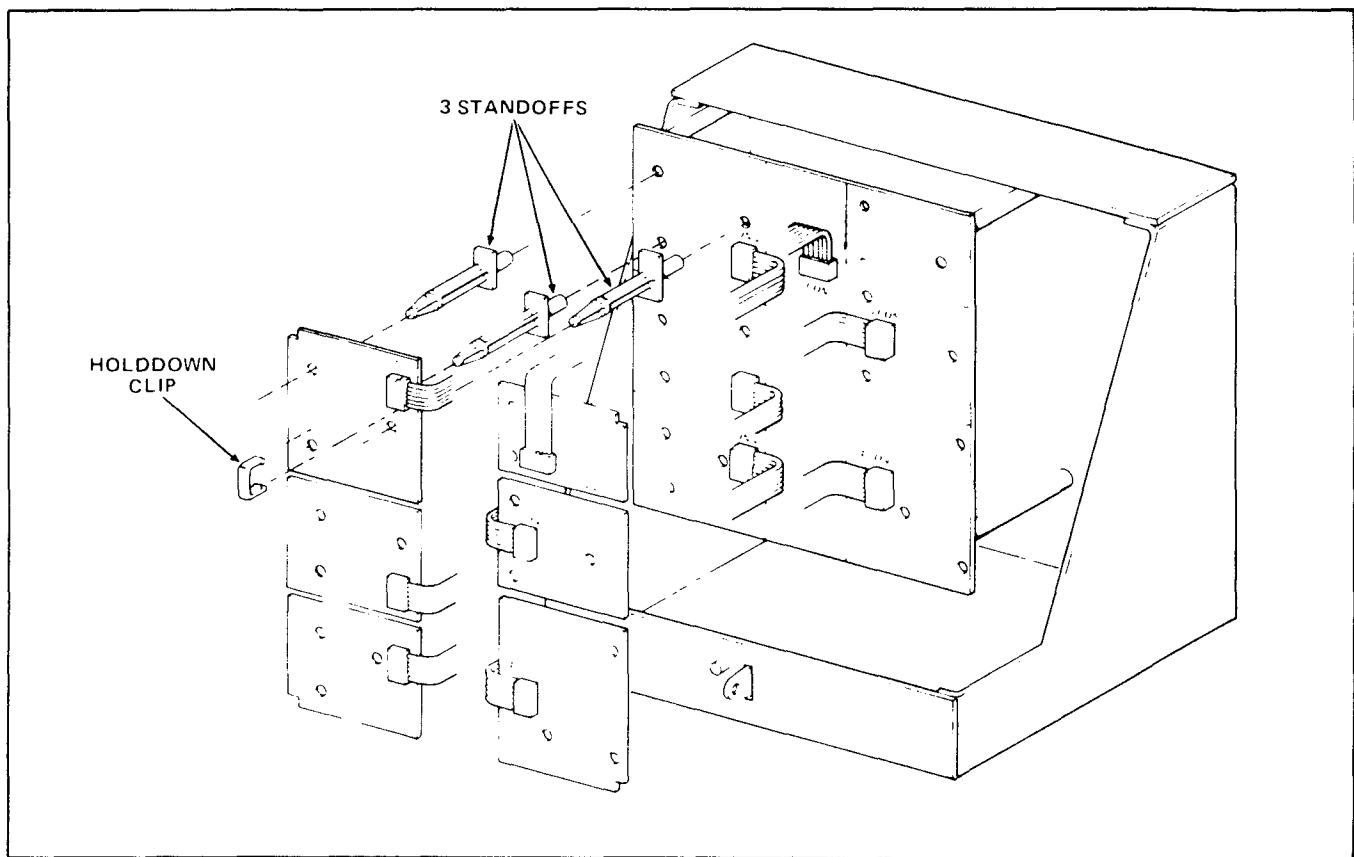

Figure 5. Modification PCB Location

B. ADJUSTMENT KNOB INSTALLATION

- 1 Turn the potentiometer wheel fully counterclockwise
- 2 Align the index line on the adjustment knob with the index line on the potentiometer wheel so that the adjustment knob index points down and left (approximately 7 o'clock position) See Figure 6
- 3 Press the adjustment knob into place over the potentiometer wheel

Note

The adjustment knob is not intended to be removed. If removal becomes necessary, do not pull knob straight out. Apply side force to disengage the adjustment knob from the potentiometer wheel.

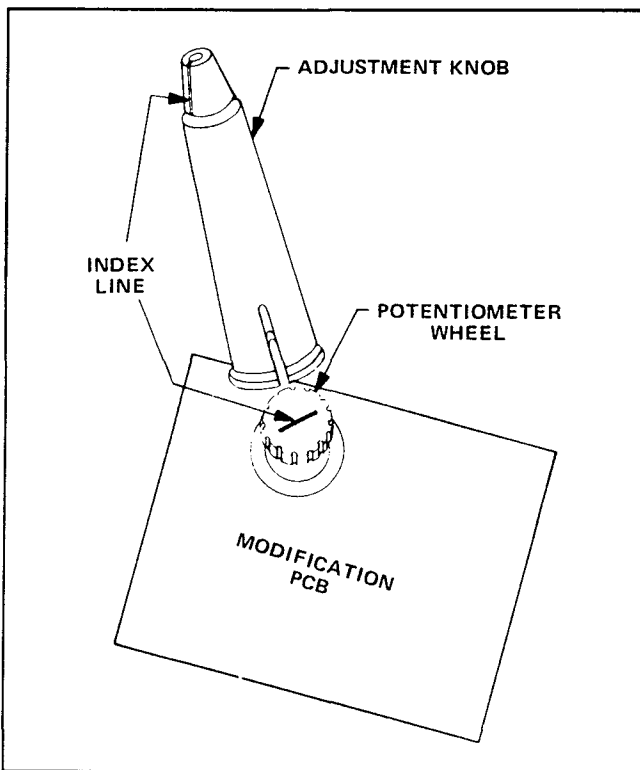

Figure 6 Adjustment Knob Installation

C. MODIFICATION IDENTIFICATION PLATE APPLICATION

- 1 Use a pen knife and cut out the holes in the Regulator cover which correspond to the adjustment knobs on the modification PCB
- 2 Remove backing from the identification plate
- 3 Align the holes in the identification plate with the holes in the Regulator cover and press the identification plate into position. See Figure 7

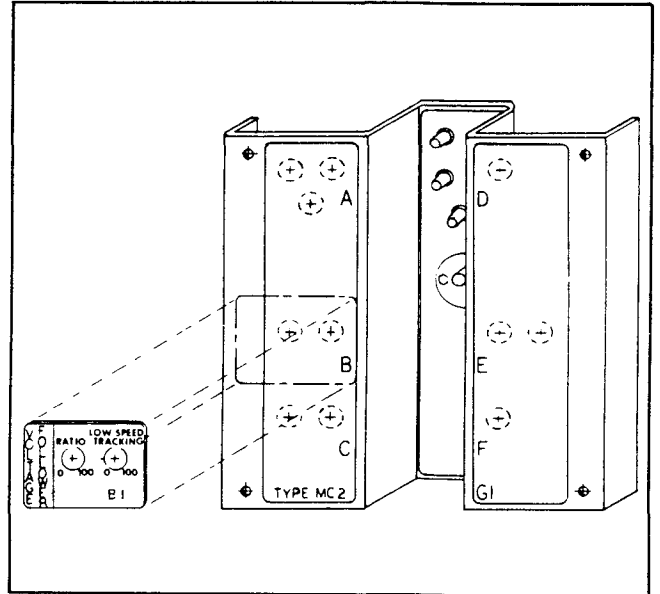

Figure 7. Identification Plate Application

D. MODIFICATION PCB REMOVAL

An extracting tool is provided with each modification kit to enable removal of the modification PCB from its standoffs. Place the extracting tool over the end of the standoff and press until the tool contacts the PCB surface. Lift edge of the board over standoff tab. Repeat for the remaining two standoffs for that modification PCB.

SCHEMATIC MODIFICATION

Each Modification Kit contains a schematic overlay to be applied to the simplified schematic diagram. Apply overlay(s) as follows:

Note

If more than one Modification Kit has been purchased, install overlays for Jog, Thread or Controlled Stop Modifications first.

- A Locate the proper position for installing schematic overlay to the simplified schematic diagram. Note that there are six Modification Areas (identified A through F). The schematic overlay will be coded for corresponding Modification Area.
- B Carefully peel paper backing from the left edge of the schematic overlay and fold back about 3/8 inch of the backing.

- C Align the schematic overlay with interconnecting wires using the corner marks on the schematic diagram as a guide.
- D Press the left edge of the schematic overlay onto the schematic diagram.
- E Peel off the remaining paper backing and at the same time press the overlay into position. DO NOT attempt to lift overlay after it has been pressed into position.

Note

In case of loss or damage, additional schematic diagrams and schematic overlays can be obtained from your nearest Louis Allis representative.

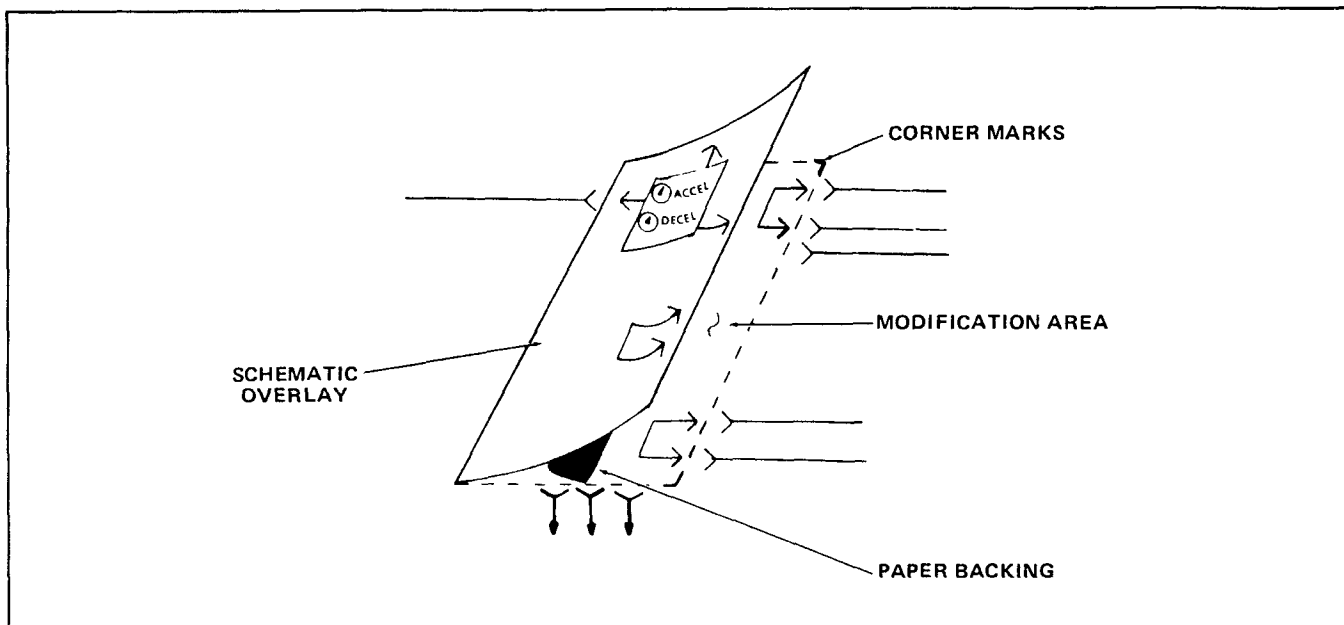
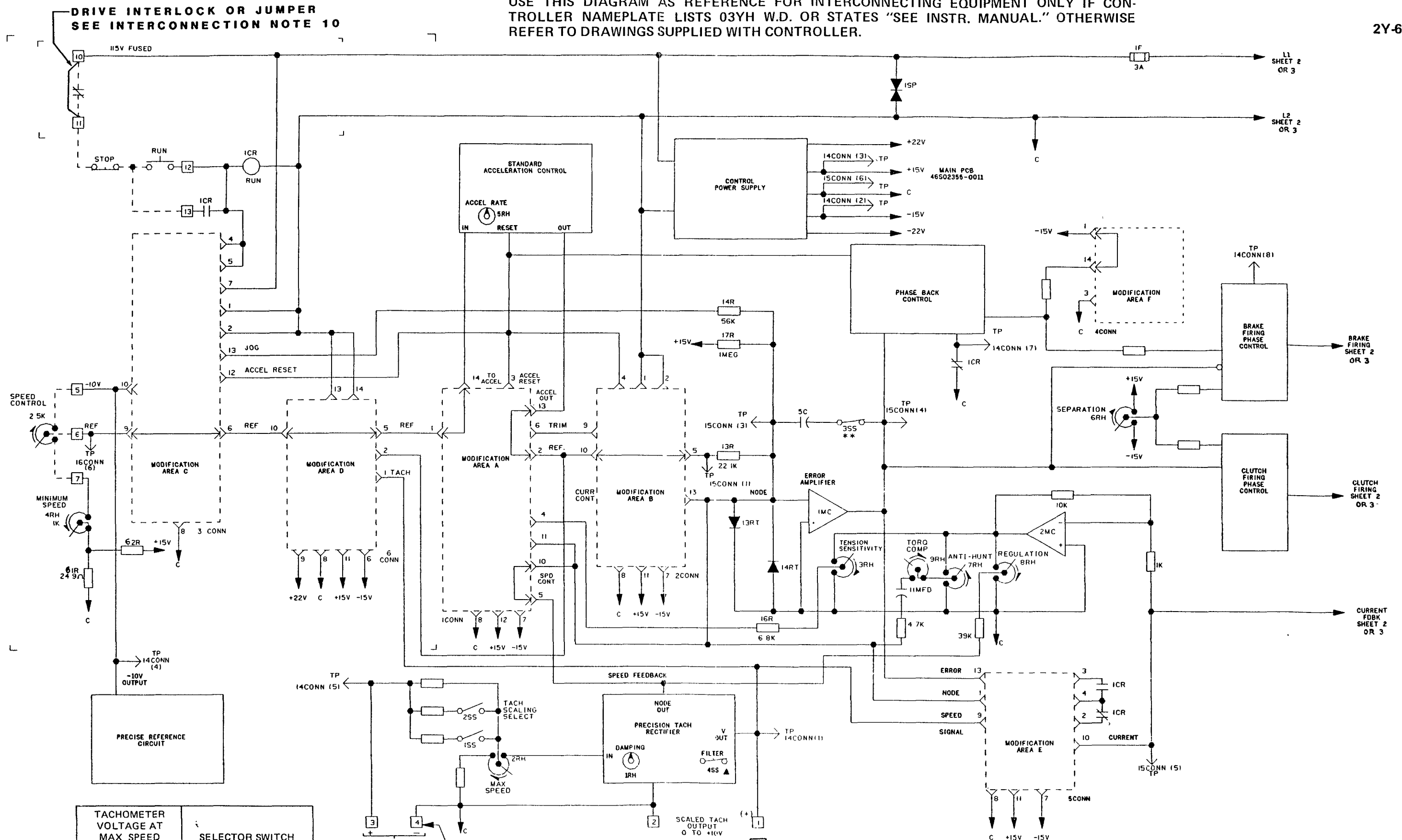

Figure 8. Application of Schematic Overlay (Typical)

USE THIS DIAGRAM AS REFERENCE FOR INTERCONNECTING EQUIPMENT ONLY IF CONTROLLER NAMEPLATE LISTS 03YH W.D. OR STATES "SEE INSTR. MANUAL." OTHERWISE REFER TO DRAWINGS SUPPLIED WITH CONTROLLER.



TACHOMETER VOLTAGE AT MAX SPEED		SELECTOR SWITCH	
VAC	VDC	1SS	2SS
17 - 40	19.2 - 48	CLOSED (SCREW IN)	CLOSED
36 - 82	40 - 98	OPEN (SCREW OUT)	CLOSED
54 - 106	60 - 150	OPEN	OPEN

xx DENOTES USERS TERMINALS
USER WIRING SHOWN DASHED

* (OPTIONAL) TO ADD SPEED INDICATOR
CONNECT LEADS TO TERMINALS
3 AND 4

** USED ONLY DURING MFG

▲ MAY BE OPENED FOR D C TACH USE

Figure 9. HCB2,5,9 and 18 Controller Simplified Schematic Diagram

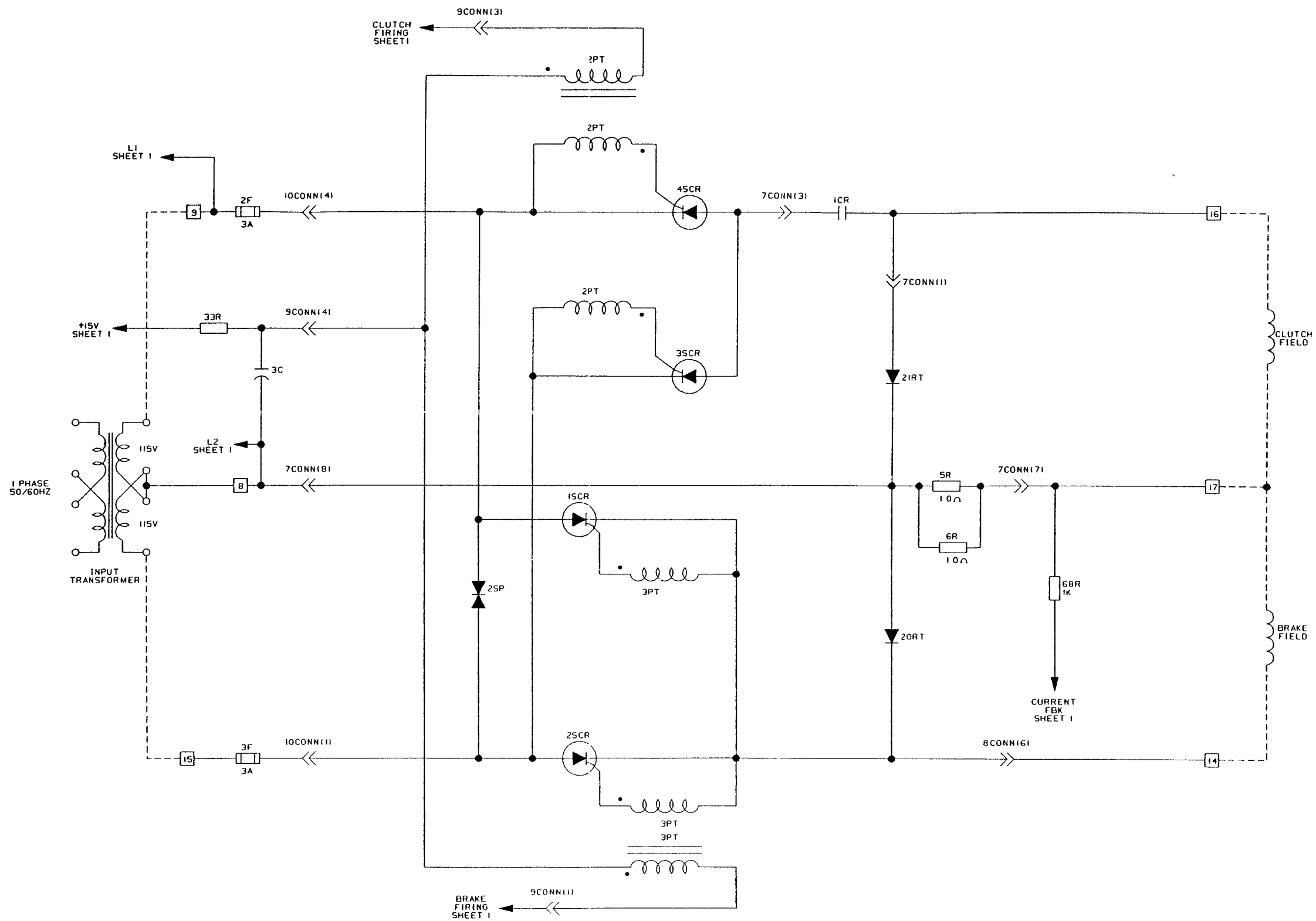
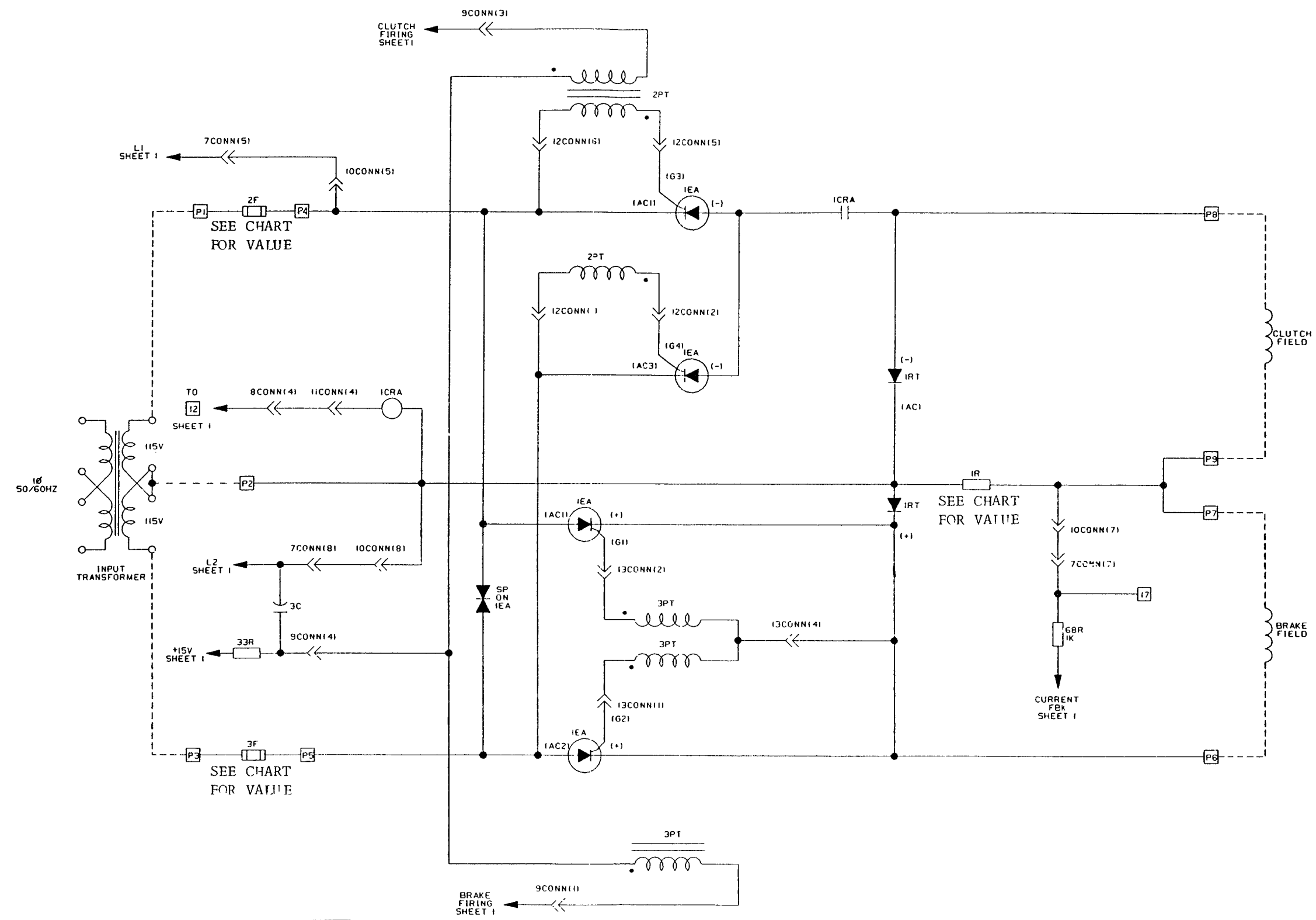

Figure 9. HCB2 Controller Simplified Schematic Diagram



CONTROLLER TYPE	FUSE 2F & 3F RATING	RESISTOR 1R VALUE
HCB5	6A	0.2 Ω
HCB9	8A	0.1 Ω
HCB18	15A	0.05 Ω

Figure 9. HCB5,9 and 18 Controller Simplified Schematic Diagram

INTERCONNECTION NOTES – CONTROLLER WITH INTEGRAL TRANSFORMER

- 1 Wire, fuse and provide overload protection as required by local codes
- 2 See AC motor, blower motor or isolating transformer nameplate for voltage selection and wire tagging for interconnections
- 3 The Mod7 Controller **MUST ALWAYS BE INTERLOCKED** with the AC motor, so that the clutch cannot be energized prior to starting the motor. Power source connections to the Controller should be made from the load side of the motor starter, or through motor starter interlock contacts
- 4 The jumper connection indicated is for applying 460VAC input to the integral transformer. When 230VAC input is used, remove the **H2** – **H3** jumper and place jumpers from **H1** to **H3** and from **H2** to **H4**
- 5 For water cooled drives, the drive unit water solenoids should be wired to the primary taps of the isolation transformer. See drive unit and transformer nameplates for required connections
- 6 Where shielded wire is specified, #18 AWG insulated shielded wire is required (2-conductor Belden #8760, 3-conductor Belden #8770, or equivalent). Connect shield at Controller end only (terminal 4) as identified in the diagram. **The far end of the shield is to be dressed neatly and left unconnected.** Provide adequate insulation on all shields to isolate them from ground and other conductors

DO NOT CONNECT SHIELDS TO EARTH GROUND!

Shielded wires should be placed in a separate conduit which does not contain power, AC control or field conductors. Within cabinets these conductors should be bundled separately from power, AC control and field conductors.

- 7 Clutch coil leads may be alternately marked F1 and F2
- 8 For interconnecting liquid-to-liquid or liquid-to-air heat exchangers, see heat exchanger instruction sheet
- 9 Blower motor fuses and/or overload protection is required only with blower ventilated units
- 10 If drive safety interlocks such as clutch overtemperature switch are provided, remove jumper between terminals **10** and **11** and wire interlock contacts in series at these terminals
- 11 Only one tach should be wired to the Controller. If DC tach is used, do not wire AC tach
- 12 Wiring for the RUN and STOP pushbuttons is different for units with Jog (C1), Thread (C2), Jog and Thread (C3) or Controlled Stop (D1) modifications installed. Connect these pushbuttons according to the instructions provided with the modification kit(s)
- 13 The SPEED CONTROL potentiometer is not used on units having modifications which enable the drive to operate only in the automatic mode. This includes the Voltage Follower (B1) and Current Follower (B2) modifications

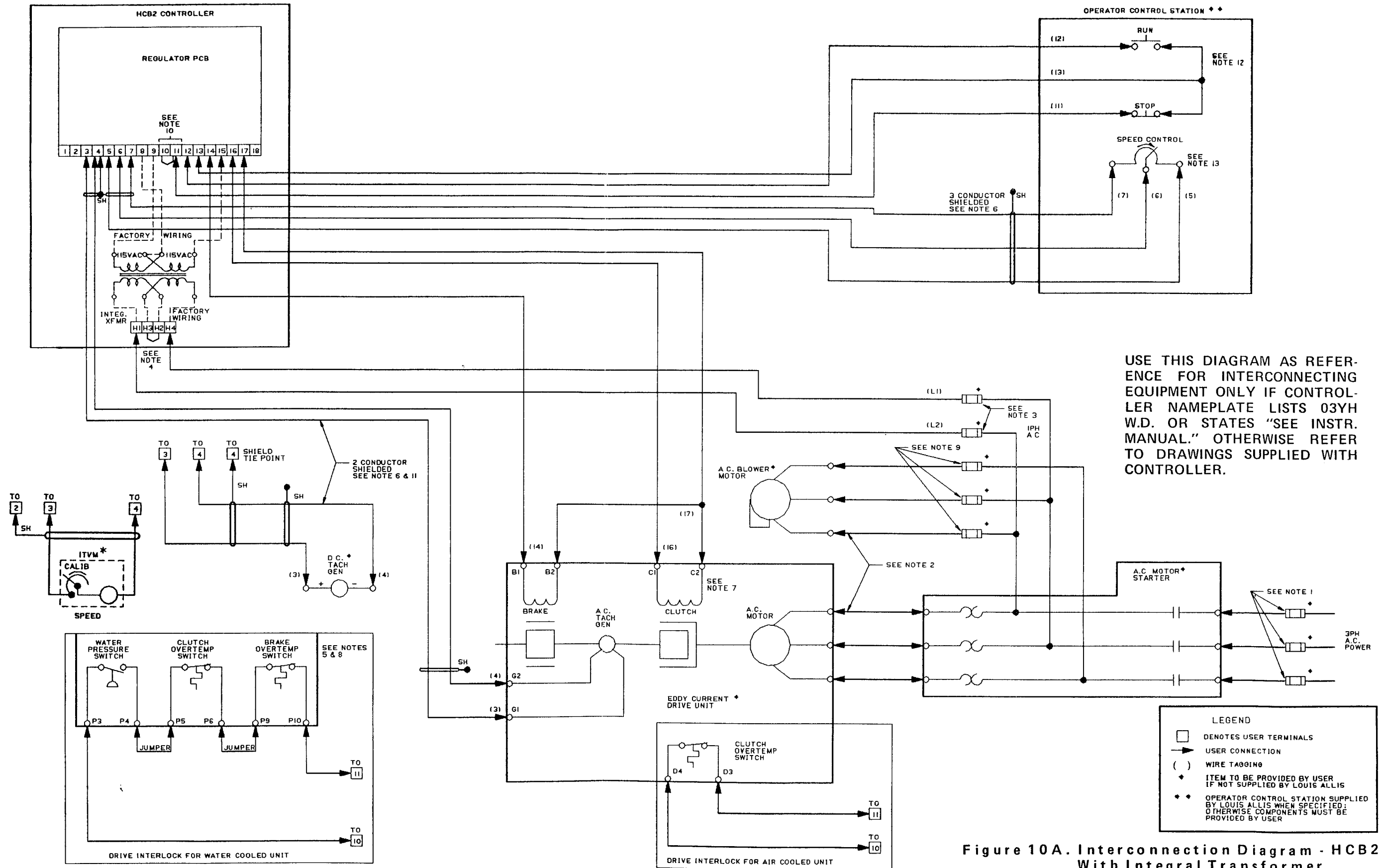

USE THIS DIAGRAM AS REFERENCE FOR INTERCONNECTING EQUIPMENT ONLY IF CONTROLLER NAMEPLATE LISTS 03YH W.D. OR STATES "SEE INSTR. MANUAL." OTHERWISE REFER TO DRAWINGS SUPPLIED WITH CONTROLLER.

Figure 10A. Interconnection Diagram - HCB2 With Integral Transformer

INTERCONNECTION NOTES – CONTROLLER WITHOUT INTEGRAL TRANSFORMER

- 1 Wire, fuse and provide overload protection as required by local codes.
- 2 See AC motor, blower motor or isolation transformer nameplate for voltage selection and wire tagging for interconnections
- 3 The Mod7 Controller **MUST ALWAYS BE INTERLOCKED** with the AC motor, so that the clutch cannot be energized prior to starting the motor. Power source connections to the Controller should be made from the load side of the motor starter, or through motor starter interlock contacts
- 4 Power supply connections to a controller with a separate input transformer should be made by referring to the transformer nameplate and one of the following figures

TRANSFORMER CONNECTIONS

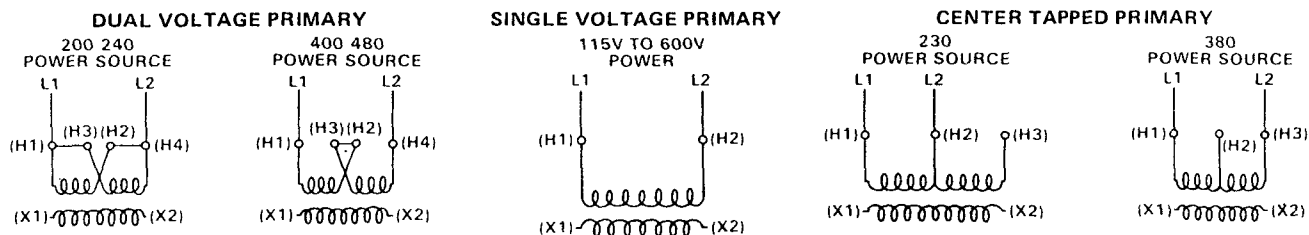

- 5 For water cooled drives, the drive unit water solenoids should be wired to the primary taps of the isolation transformer. See drive unit and transformer nameplates for required connections.
- 6 Where shielded wire is specified, #18 AWG insulated shielded wire is required (2-conductor Belden #8760, 3-conductor Belden #8770, or equivalent) **Connect shield at Controller end only (terminal 4)** as identified in the diagram. **The far end of the shield is to be dressed neatly and left unconnected.** Provide adequate insulation on all shields to isolate them from ground and other conductors

DO NOT CONNECT SHIELDS TO EARTH GROUND!

Shielded wires should be placed in a separate conduit which does not contain power, AC control or field conductors. Within cabinets these conductors should be bundled separately from power, AC control and field conductors.

- 7 Clutch coil leads may be alternately marked F1 and F2
- 8 For interconnecting liquid-to-liquid or liquid-to-air heat exchangers, see heat exchanger instruction sheet
- 9 Blower motor fuses and/or overload protection is required only with blower ventilated units
- 10 If drive safety interlocks such as clutch overtemperature switch are provided, remove jumper between terminals **10** and **11** and wire interlock contacts in series at these terminals
- 11 Only one tach should be wired to the Controller. If DC tach is used, do not wire AC tach
- 12 Wiring for the RUN and STOP pushbuttons is different for units with Jog (C1), Thread (C2), Jog and Thread (C3) or Controlled Stop (D1) modifications installed. Connect these pushbuttons according to the instructions provided with modification kit(s)
- 13 The SPEED CONTROL potentiometer is not used on units having modifications which enable the drive to operate only in the automatic mode. This includes the Voltage Follower (B1) and Current Follower (B2) modifications

INTERCONNECTION NOTES – CONTROLLER WITHOUT INTEGRAL TRANSFORMER

- 1 Wire, fuse and provide overload protection as required by local codes
- 2 See AC motor, blower motor or isolation transformer nameplate for voltage selection and wire tagging for interconnections
- 3 The Mod7 Controller **MUST ALWAYS BE INTERLOCKED** with the AC motor, so that the clutch cannot be energized prior to starting the motor. Power source connections to the Controller should be made from the load side of the motor starter, or through motor starter interlock contacts
- 4 Power supply connections to a controller with a separate input transformer should be made by referring to the transformer nameplate and one of the following figures

TRANSFORMER CONNECTIONS

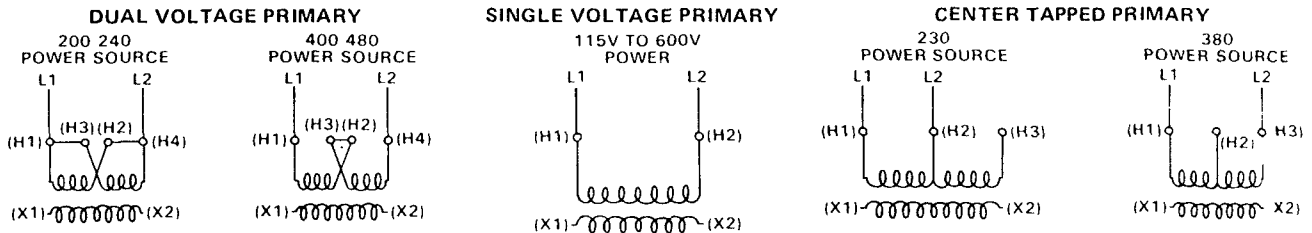

- 5 For water cooled drives, the drive unit water solenoids should be wired to the primary taps of the isolation transformer. See drive unit and transformer nameplates for required connections
- 6 Where shielded wire is specified, #18 AWG insulated shielded wire is required (2-conductor Belden #8760, 3-conductor Belden #8770, or equivalent). Connect shield at Controller end only (terminal 4) as identified in the diagram. The far end of the shield is to be dressed neatly and left unconnected. Provide adequate insulation on all shields to isolate them from ground and other conductors

DO NOT CONNECT SHIELDS TO EARTH GROUND!

Shielded wires should be placed in a separate conduit which does not contain power, AC control or field conductors. Within cabinets these conductors should be bundled separately from power, AC control and field conductors.

- 7 Clutch coil leads may be alternately marked F1 and F2
- 8 For interconnecting liquid-to-liquid or liquid-to-air heat exchangers, see heat exchanger instruction sheet
- 9 Blower motor fuses and/or overload protection is required only with blower ventilated units
- 10 If drive safety interlocks such as clutch overtemperature switch are provided, remove jumper between terminals **10** and **11** and wire interlock contacts in series at these terminals
- 11 Only one tach should be wired to the Controller. If DC tach is used, do not wire AC tach
- 12 Wiring for the RUN and STOP pushbuttons is different for units with Jog (C1), Thread (C2), Jog and Thread (C3) or Controlled Stop (D1) modifications installed. Connect these pushbuttons according to the instructions provided with modification kit(s)
- 13 The SPEED CONTROL potentiometer is not used on units having modifications which enable the drive to operate only in the automatic mode. This includes the Voltage Follower (B1) and Current Follower (B2) modifications

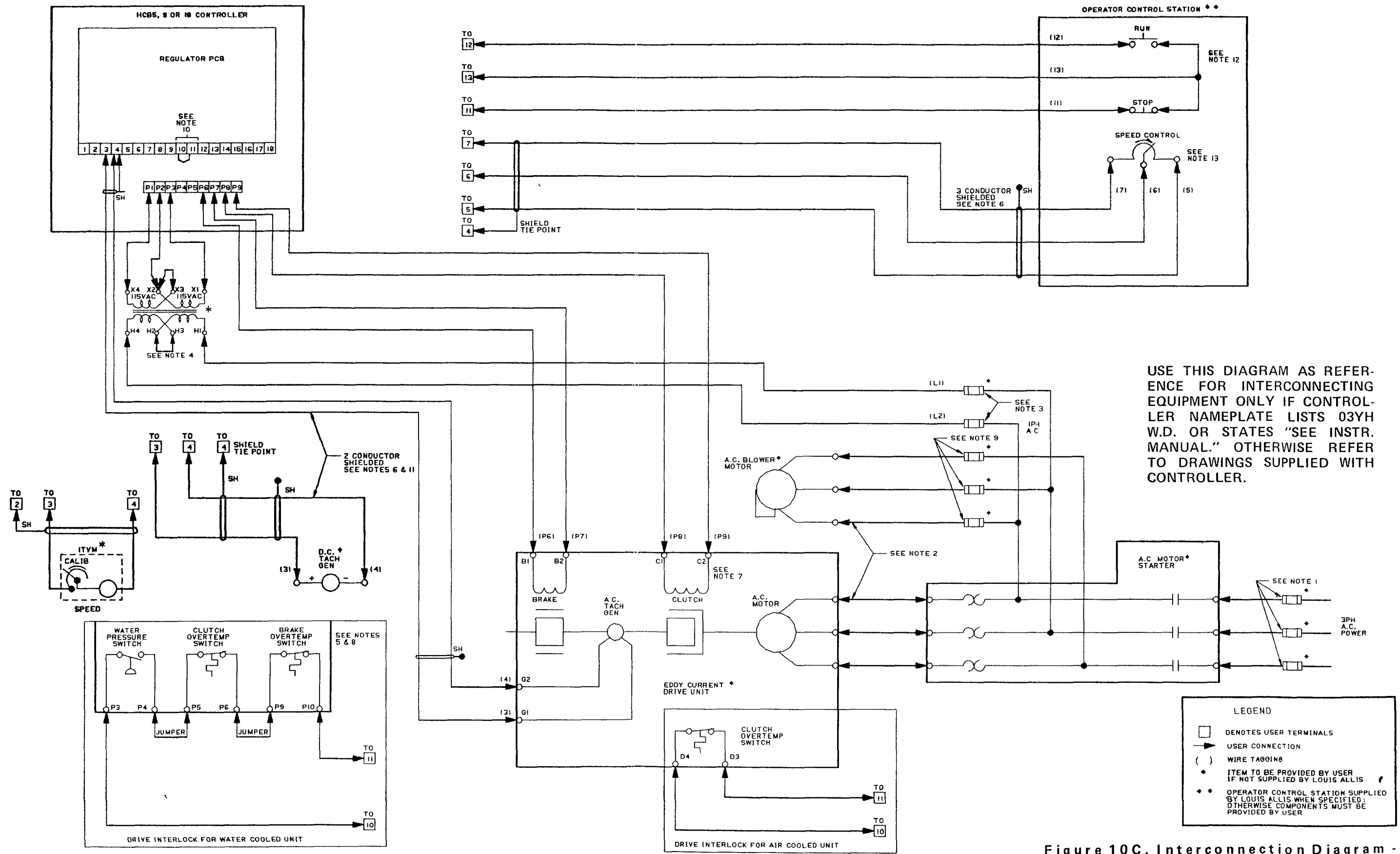

USE THIS DIAGRAM AS REFERENCE FOR INTERCONNECTING EQUIPMENT ONLY IF CONTROLLER NAMEPLATE LISTS 03YH W.D. OR STATES "SEE INSTR. MANUAL." OTHERWISE REFER TO DRAWINGS SUPPLIED WITH CONTROLLER.

Figure 10C. Interconnection Diagram - HCB5, 9 or 18

INSTRUCTIONS FOR INTERCONNECTING EQUIPMENT

- A Place a check in column ① to correspond to each applicable item of equipment listed in column ②
- B For each checked equipment item, connect wires between points identified in columns ④ and ⑤ using the wire type identified in column ⑥. Refer to the typical interconnection diagrams for illustrations of these interconnections
- C Label interconnecting wires using the wire numbers given in column ③. It may be necessary to refer to rotating equipment nameplate for lead designation
- D If modification kits are also being installed, follow additional interconnection instructions provided with the modification kits

TABLE 4 EQUIPMENT IDENTIFICATION

EQUIP NO	NAME
1	AC Motor
1A	Clutch Field
1B	Brake Coil
1C	AC Tach Gen or DC Tach Gen
1D	Clutch Overtemp Switch
1E	Water Pressure Switch
1F	Brake Overtemp Switch
2	Controller
3	Input Transformer
4	Operator Control Station
4A	SPEED CONTROL Potentiometer
4B	RUN Pushbutton
4C	STOP Pushbutton

USE THIS TABLE AS REFERENCE FOR INTERCONNECTING EQUIPMENT ONLY IF CONTROLLER NAMEPLATE LISTS 03YH W.D. OR STATES "SEE INSTR. MANUAL." OTHERWISE REFER TO DRAWINGS SUPPLIED WITH CONTROLLER.

TABLE 5 INTERCONNECTION TABLE

CHECK APPLICABLE EQUIPMENT ITEMS	EQUIPMENT	WIRE NO	FROM		TO		WIRE TYPE (ALL 15A OR LESS EXCEPT AS NOTED)
			EQUIPMENT NO (See Table 4)	TB OR OTHER MARKING	EQUIPMENT NO (See Table 4)	TB OR OTHER MARKING	
ROTATING EQUIPMENT	() Clutch (Equipment No. 1A) With HCB2 Controllers	16	2	TB(16)	1A	F1 or C1	
		17		TB(17)		F2 or C2	
	() Clutch (Equipment No. 1A) With HCB5 9 & 18 Controllers	P8	2	P8	1A	F1 or C1	(HCB 18 20 AMPS)
		P9		P9		F2 or C2	
	() Brake (Equipment No. 1B) With HCB2 Controllers	14	2	TB(14)	1B	B1	
		17		TB(17)		B2	
	() Brake (Equipment No. 1B) With HCB5 9 & 18 Controllers	P6	2	P6	1B	B1	(HCB 18 20 AMPS)
		P7		P7		B2	
	() AC Tach Gen See Note 11 (Equipment No. 1C)	3	2	TB(3)	1C	G1	2 Conductor Shielded Cable See Note 6
		4		TB(4)		G2	
		Shield		TB(4)		No Connection	
	() DC Tach Gen See Note 11 (Equipment No. 1C)	3	2	TB(3)	1C	(+)	2 Conductor Shielded Cable See Note 6
		4		TB(4)		(-)	
		Shield		TB(4)		No Connection	
() Drive Interlock (Air Cooled Units) See Note 10 (Equipment No. 1D)	10	2	TB(10)	1D	D3		
	11		TB(11)		D4		
() Drive Interlock (Water Cooled Units) See Note 10 (Equipment No. 1D, 1E & 1F)	10	2	TB(10)	1E	(P3)		
	11		TB(11)		1F		(P10)
	AA	1E	(P4)	1D	(P5)		
	BB	1D	(P6)	1F	(P9)		
CONTROLLER & XFMR (AIR COOLED UNITS)	() HCB2 Controller with Integral Xfmr (Air Cooled Units) See Notes 1, 2, 3 & 4 (Equipment No. 2)	L1	Power Source	L1	2	TB(H1)	
		L2		L2		TB(H4)	
	() HCB2 Controller with Separate Xfmr (Air Cooled Units) See Notes 1, 2, 3 & 4 (Equipment No. 2 & 3)	L1	Power Source	L1	3	H1	
		L2		L2		H4	
		9	3	X1	2	TB(9)	
		8		X2		TB(8)	
	15	X4	TB(15)				
	() HCB5 9 & 18 Controller with Separate Xfmr (Air Cooled Units) See Notes 1, 2, 3 & 4 (Equipment No. 2 & 3)	L1	Power Source	L1	3	H1	(HCB 18 20 AMPS)
		L2		L2		H4	
		P1	3	X1	2	P1	
		P2		X2		P2	
		P3		X4		P3	
CONTROLLER & XFMR (WATER COOLED UNITS)	() HCB2 Controller with Integral Xfmr (Water Cooled Units) See Notes 1, 2, 3, 4 & 5 (Equipment No. 2)	L1	Power Source	L1	2	TB(H1)	
		L2		L2		TB(H4)	
	() HCB2 Controller with Separate Xfmr (Water Cooled Units) See Notes 1, 2, 3, 4 & 5 (Equipment No. 2 & 3)	L1	Power Source	L1	3	H1	
		L2		L2		H4	
			1	P2	3	H1	
				P1		H2	
				P7		H3	
		8	3	P8	2	H4	
	9	X2		TB(8)			
	15	X1	TB(9)				
	X4	TB(15)					
() HCB5 9 & 18 Controller with Separate Xfmr (Water Cooled Units) See Notes 1, 2, 3, 4 & 5 (Equipment No. 2 & 3)	L1	Power Source	L1	3	H1	(HCB 18 20 AMPS)	
	L2		L2		H4		
		1	P2	3	H1		
			P1		H2		
			P7		H3		
	P1	3	P8	2	H4		
	P2		X1		TB(P1)		
P3	X2	TB(P2)					
	X4	TB(P3)					
OPERATOR CONTROL STATION	(*) SPEED CONTROL Potentiometer See Note 13 (Equipment No. 4A)	5	2	TB(5)	4A	Left Terminal Mid Terminal Rt Terminal No Connection	3 Conductor Shielded Cable See Note 6
		6		TB(6)			
		7		TB(7)			
		Shield		TB(4)			
	(*) RUN Pushbutton See Note 12 (Equipment No. 4B)	12	2	TB(12)	4B	a	
		13		TB(13)		b	
(*) STOP Pushbutton See Note 12 (Equipment No. 4C)	11	2	TB(11)	4C	c		
	13		TB(13)		d		

* If controller has modifications(s) included, first, refer to installation procedures

LEGEND, Figure 12

- 1 Regulator PCB
- 2 14CONN, Test Points
- 3 15CONN, Test Points
- 4 6RH, Separation pot
- 5 4RH, Minimum Speed pot
- 6 8RH, Regulation pot
- 7 5RH, Accel Rate pot
- 8 1RH, Damping pot
- 9 3RH, Tension Sensitivity pot
- 10 2RH, Maximum Speed pot
- 11 9RH, Torq Comp pot
- 12 7RH, Anti-Hunt pot
- 13 Continuity Plug 6CONN
- 14 7CONN, 8CONN & 9CONN, connections to Power Bridge, behind Regulator PCB
- 15 10 RH, Adj Brake pot
- 16 1CR, Run relay
- 17 Terminal Strip P1-P9 (not in HCB2), behind lower edge of Regulator PCB
- 18 Jumper, factory installed, Drive Without Interlock
- *19 Terminal Block H1-H4 (only with integral XFMR)
- *20 Jumper, factory installed (see Interconnection Note 4)
- *21 Integral Input Transformer (when supplied)
- 22 Fuses 2F & 3F (mounted to lower corner of panel on Controller without enclosure)
- 23 Switch 4SS
- 24 Continuity Plug 3CONN
- 25 1PT, Control Power Supply transformer
- 26 Switches 1SS & 2SS, Tach Scaling
- 27 Continuity Plug 2CONN
- 28 Fuse 1F (fuse retainer secures Regulator cover in place)
- 29 Continuity Plug 1CONN

*Only on HCB2 with enclosure.

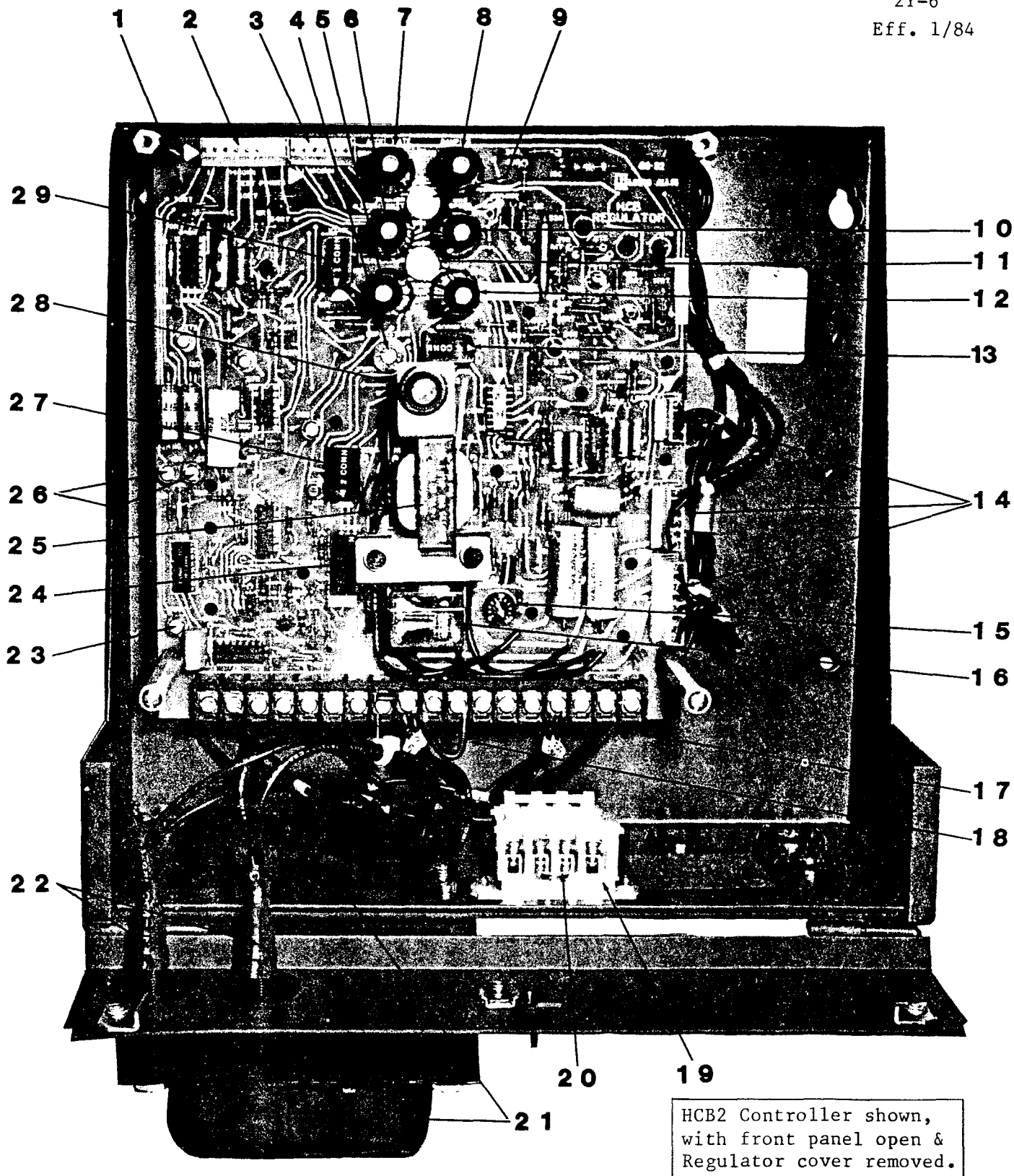

Figure 12. HCB Controller, Major Component Location

Power and control products including Solid State starters, Eddy Current drives, DC drives and Adjustable Frequency drives

(800) 541-0939, (414) 782-0200, FAX (414) 782-1283

M *MagneTek*
Drives & Systems

16555 W Ryerson Road
New Berlin, WI 53151

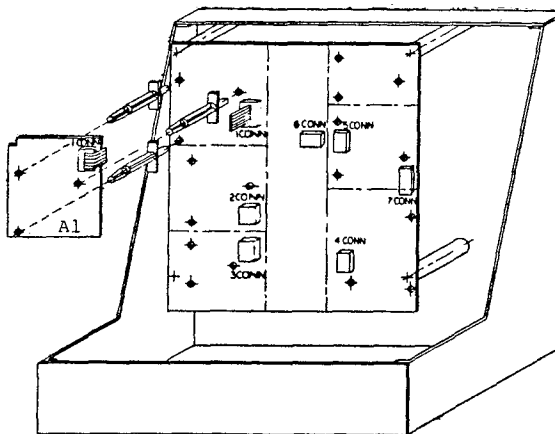

MOD PCB
46SO2042-0020
SCHEMATIC
45SO2042-0020

DESCRIPTION

This modification kit is one of a series of kits available for the Louis Allis eddy current drives. It consists of components necessary for modifying the basic Controller for the linear accel/decel function. It also includes front panel nameplates and modification diagrams for the basic MOD 7 Controller instruction manual.

The addition of this assembly to the Controller enables the operator to separately adjust the acceleration and deceleration rates for a drive operating in the Speed Mode. Both rates are adjustable from 2.4 seconds to 40 seconds for a 100% change in drive speed. Input to the assembly is the Speed Reference signal from the SPEED CONTROL potentiometer of modification installed in area C or D. Output is applied to the speed regulator via any modification installed in area B. The assembly's controlled acceleration output is automatically reset to zero each time the STOP button is pressed or each time the drive is transferred to the automatic mode (if the drive is equipped with a Follower Assembly modification B3 or B4).

INSTALLATION

WARNING
REMOVE ALL INPUT POWER TO DRIVE
BEFORE INSTALLING MODIFICATION KIT.

This modification PCB is to be installed to area A of the Regulator PCB as shown in the illustration on this page. Installation instructions are contained in the Controller instruction manual.

After installing the modification PCB, apply the schematic overlay to area A of the simplified schematic diagram as described in the Controller instruction manual.

If extended acceleration and deceleration rates are desired, select a capacitor which provides the desired rates and connect between terminals A1(-) and A2(+) of the assembly terminal board.

INTERCONNECTION

This modification requires no special interconnections.

Perform equipment interconnection according to the Controller instruction manual.

ADJUSTMENTS

After performing the adjustments in the Controller instruction manual, adjust the modification PCB as follows;

1. Turn the ACCEL RATE potentiometer (5RH of Regulator PCB) fully clockwise.
2. Turn the ACCEL RATE and DECEL RATE potentiometers on the modification PCB full counterclockwise. Turn the SPEED CONTROL to zero and start the drive.
3. Turn the SPEED CONTROL fully clockwise and observe drive acceleration rate. Then turn SPEED CONTROL fully counterclockwise and note deceleration rate.
4. Adjust ACCEL RATE and DECEL RATE potentiometers on the modification PCB as required to obtain desired rates. If desired rates cannot be obtained, perform modification kit troubleshooting procedures.

TROUBLESHOOTING

If other mod boards have been installed, be sure to troubleshoot them thoroughly before discarding this board as faulty.

Troubleshooting consists of checking the input and output voltages of the circuit while the drive is operating.

INSTRUCTION SHEET
FOR MODIFICATION A1
Sheet 1 of 2
02Y00025-0003

1. Start the drive and rotate SPEED CONTROL fully clockwise.
2. Refer to the schematic diagram of the Linear Accel/Decel PCB and check input voltage between A1TP and I2CONN(6) of the Regulator PCB (common). Voltage should be approximately -10 VDC. If voltage is incorrect, refer to the troubleshooting charts in the Controller instruction manual.
3. Check output voltage between A2TP and I2CONN(6) (common). Voltage should be approximately -10 VDC. If voltage is incorrect, replace Linear Accel/Decel PCB.
4. Press STOP button and stop the drive. Again monitor voltage at A2TP. Voltage should be zero. If voltage is incorrect, replace Linear Accel/Decel PCB. If voltage is correct, restart drive.
5. Turn SPEED CONTROL fully counterclockwise and check input voltage between A1TP and I2CONN(6) of Regulator PCB. Voltage should be zero to -3 VDC depending on MIN SPEED potentiometer setting. If voltage is incorrect, refer to the troubleshooting charts in the Controller instruction manual.
6. Check output voltage between A2TP and I2CONN(6) (common). Voltage should be the same as voltage obtained in step 5, above. If voltage is incorrect, replace Linear Accel/Decel PCB.
7. If the acceleration or deceleration rate cannot be adjusted over the proper range or operation is erratic, replace Linear Accel/Decel PCB.

MODIFICATION RECORDS

After completing mod kit installation:

- A. Modify Controller identification number using Method 1 in the Controller instruction manual. Place the number "1" in the block corresponding to modification area A.
- B. Insert this instruction sheet inside the back cover of the Controller instruction manual.

MODIFICATION A2
FOR EDDY CURRENT DRIVE
(KIT P/N 46SO2051-0010)
LINEAR ACCEL/DECEL WITH S CURVE

Effective
2-6-81
Supersedes
7-77

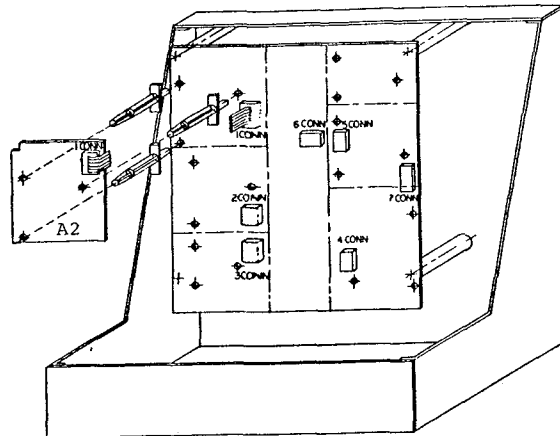

MOD PCB
46SO2042-0010
SCHEMATIC
45SO2042-0010

DESCRIPTION

This modification is one of a series of kits available for the Louis Allis eddy current drives. It consists of components necessary for modifying the basic Controller for the linear accel/decel function. It also includes front panel nameplates and modification diagrams for the basic MOD 7 Controller instruction manual.

The addition of this assembly to the Controller enables the operator to separately adjust the acceleration and deceleration rates for a drive operating in the Speed Mode. Both rates are adjustable from 3.0 seconds to 40.6 seconds for a 100% change in drive speed. Input to the assembly is the Speed Reference signal from the SPEED CONTROL potentiometer or modifications installed in area C or D. Output is applied to the speed regulator via any modifications installed in area B. The assembly's controlled acceleration output is automatically reset to zero each time the STOP button is pressed or each time the drive is transferred to the automatic mode if the drive is equipped with a Follower Assembly modification B3 or B4. An internal RC network softens the transition points in the speed reference signal to allow smoother operation when multiple drives are cascaded.

The controlled deceleration action occurs only when the SPEED CONTROL setting is effectively reduced. The use of this modification alone does not constitute a controlled stop function since the accel/decel output is quickly reset to zero each time the STOP pushbutton is pressed.

INSTALLATION

WARNING

REMOVE ALL INPUT POWER TO DRIVE BEFORE INSTALLING MODIFICATION KIT

This modification PCB is to be installed to area A of the Regulator PCB as shown in the illustration on this page. Installation instructions are contained in the Controller instruction manual.

After installing the modification PCB, apply the schematic overlay to area A of the simplified schematic diagram as described in the Controller instruction manual.

If extended acceleration and deceleration rates are desired, select a capacitor which provides the desired rates and connect between terminals A1(-) and A2(+) of the assembly terminal board.

INTERCONNECTIONS

This modification requires no special interconnections.

Perform equipment interconnection according to the Controller instruction manual.

ADJUSTMENTS

After performing the adjustments in the Controller instruction manual, adjust the modification PCB as follows.

1. Turn the ACCEL RATE potentiometer (5RH of Regulator PCB) fully clockwise.
2. Turn the ACCEL RATE and DECEL RATE potentiometers on the modification PCB fully counterclockwise. Turn the SPEED CONTROL to zero and start the drive.
3. Turn the SPEED CONTROL fully clockwise and observe drive acceleration rate. Then turn SPEED CONTROL fully counterclockwise and note deceleration rate.
4. Adjust ACCEL RATE and DECEL RATE potentiometers on the modification PCB as required to obtain desired rates.
5. If desired rates cannot be obtained, perform modification kit troubleshooting procedures.

INSTRUCTION SHEET
FOR MODIFICATION A2
Sheet 1 of 2
02Y00025-0002

TROUBLESHOOTING

If other mod boards have been installed, be sure to troubleshoot them thoroughly before discarding this board as faulty.

Troubleshooting consists of checking the input and output voltages of the circuit while the drive is operating.

1. Start the drive and rotate SPEED CONTROL fully clockwise.
2. Refer to the schematic diagram of the Linear Accel/Decel PCB and check input voltages between A1TP and I2CONN(6) of the Regulator PCB (common). Voltage should be approximately -10 VDC. If voltage is incorrect, refer to the troubleshooting charts in the Controller instruction manual.
3. Check output voltage between A2TP and I2CONN(6) (common). Voltage should be approximately -10 VDC. If voltage is incorrect, replace Linear Accel/Decel PCB.
4. Press STOP button and stop the drive. Again monitor voltage at A2TP. Voltage should be zero. If voltage is incorrect, replace Linear Accel/Decel PCB. If voltage is correct, restart drive.
5. Turn SPEED CONTROL fully counterclockwise and check input voltage between A1TP and I2CONN(6) of Regulator PCB. Voltage should be zero to -3 VDC depending on MIN SPEED potentiometer setting. If voltage is incorrect, refer to the troubleshooting charts in the Controller instruction manual.
6. Check output voltage between A2TP and I2CONN(6) (common). Voltage should be the same as voltage obtained in step 5, above. If voltage is incorrect, replace Linear Accel/Decel PCB.
7. If the acceleration and deceleration rate cannot be adjusted over the proper range or operation is erratic, replace Linear Accel/Decel PCB.

MODIFICATION RECORDS

After completing mod kit installation:

- A. Modify Controller identification number using Method 1 in the Controller instruction manual. Place the number "2" in the block corresponding to modification area A.
- B. Insert this instruction sheet to inside the back cover of the Controller instruction manual.

MODIFICATION A5
 FOR EDDY CURRENT DRIVE
 (KIT P/N 46SO2051-0210)
 CLUTCH CURRENT

Effective
 2-16-81
 Supersedes
 7-77

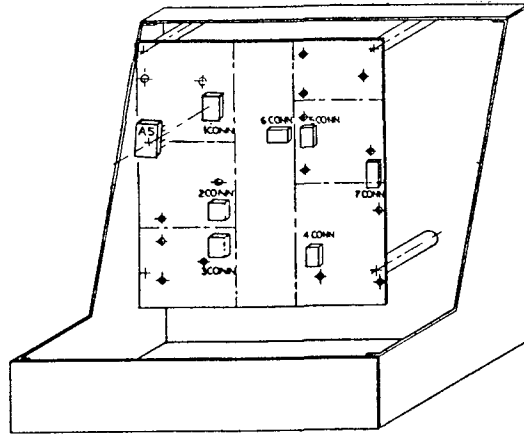

MOD PCB
 46SO2064-0050
 SCHEMATIC
 NONE (See Note under
 Installation)

DESCRIPTION

This modification kit is one of a series of kits available for the Louis Allis eddy current drives. It consists of components necessary for placing the basic Controller in a clutch current mode of operation at all times. It also includes front panel nameplates and modification diagrams for the basic MOD 7 Controller instruction manual.

This modification is a jumper plug which is inserted into the 1CONN connector. The clutch current reference is supplied to the modification through an external 2.5K ohm potentiometer normally used for speed control. The clutch current reference signal bypasses the Acceleration Control circuit when this modification is installed

INSTALLATION

WARNING
 REMOVE ALL INPUT POWER TO DRIVE BEFORE INSTALLING MODIFICATION KIT

This modification plug is to be installed to area A of the Regulator PCB as shown in the illustration on this page, by removing the continuity plug from 1CONN and inserting the modification plug in its place.

After installing the modification plug, apply the schematic overlay to area A of the simplified schematic diagram as described in the Controller instruction manual.

NOTE

The schematic overlay indicates the jumper wires internal to the modification plug.

INTERCONNECTION

Perform equipment interconnection according to the Controller instruction manual

NOTE

The instruction manual schematic illustrates the external 2.5K ohm pot labeled as SPEED control. After interconnections are completed, change the schematic marking to read CURRENT Control

ADJUSTMENTS

After performing the adjustments in the Controller instruction manual, perform the following adjustments.

1. Set the external clutch current potentiometer fully clockwise.
2. Adjust the TENSION SENSITIVITY potentiometer on the Regulator PCB for desired maximum clutch current.
3. Set the external clutch current potentiometer for desired operating clutch current.

TROUBLESHOOTING

Troubleshooting consists of checking continuity of the modification plug as follows:

<u>From</u>	<u>To</u>
Pin 1	Pin 2
Pin 4	Pin 11

Replace the Clutch Current plug if defective.

MODIFICATION RECORDS

After completing mod kit installation:

- A. Modify Controller identification number using Method 1 in the Controller instruction manual Place the number "5" in the block corresponding to modification area A.
- B. Insert this instruction sheet inside the back cover of the Controller instruction manual.

INSTRUCTION SHEET
 FOR MODIFICATION A5
 Sheet 1 of 1
 02Y00025-0022

MODIFICATION A6
FOR EDDY CURRENT DRIVE
(KIT P/N 46SO2051-0191)
CLUTCH CURRENT/SPEED

Effective
2-5-81
Supersedes
12-78

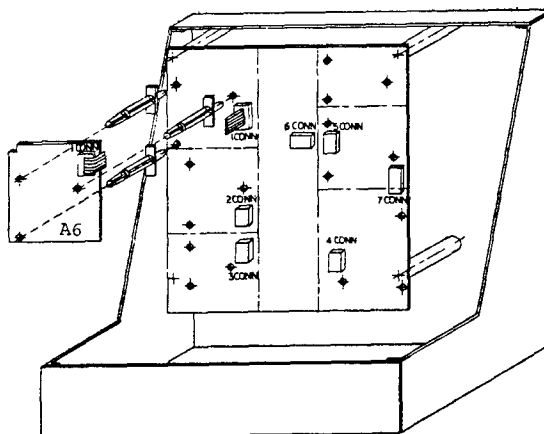

MOD PCB
46SO2050-0031
SCHEMATIC
45SO2050-0031

DESCRIPTION

This modification kit is one of a series of kits available for the Louis Allis eddy current drives. It consists of components necessary for modifying the basic Controller to allow the operator to switch from speed control to clutch current, or direct torque, control. It also includes front panel nameplates and modification diagrams for the basic MOD 7 Controller instruction manual.

The addition of this modification to the Controller enables the operator to select speed control or current control drive operation by means of a remote selector switch. When operating in speed control (MAN/AUTO switch in the MAN position), the speed reference is supplied to the modification from the SPEED CONTROL potentiometer via the acceleration Control circuit or other modification. When operating in current control (MAN/AUTO switch in the AUTO position), the Acceleration Control circuit is reset to zero and the current reference is supplied to the modification at terminal board connection A3. In this operating mode, the torque output of the drive is proportional to the clutch field current at speeds less than 80 percent of top speed.

INSTALLATION

WARNING
REMOVE ALL INPUT POWER TO DRIVE BEFORE INSTALLING MODIFICATION KIT.

This modification PCB is to be installed to area A of the Regulator PCB as shown in the illustration on this page. Installation instructions are contained in the Controller instruction manual.

After installing the modification PCB, apply the two schematic overlays to area A of the simplified schematic diagram and to the area directly above modification area C as described in the Controller instruction manual.

INTERCONNECTION

This modification requires that a two-position MAN/AUTO selector switch be added to the operator control station. Perform interconnections according to the chart in the Controller instruction manual. Then perform interconnection as shown in the attached table and diagram

Depending on the application, the SPEED CONTROL potentiometer may be used for both speed control and current (torque) control adjustments or a separate potentiometer may be added for current control adjustment. Addition of a separate current control potentiometer enables presetting of speed and current adjustments. If the potentiometer is not added, the SPEED CONTROL potentiometer must be reset whenever the MAN/AUTO selector switch position is changed. If a separate current control potentiometer is not used, wire terminal A3 of the Clutch Current/Speed PCB to the wiper of the SPEED CONTROL potentiometer as shown in diagram A. If a separate current control potentiometer is used, wire as shown in diagram B.

ADJUSTMENTS

1. Place the MAN/AUTO selector switch to MAN and perform adjustments contained in the Controller instruction manual.
2. Place the MAN/AUTO selector switch to AUTO. If a separate current control potentiometer is used, turn the current control potentiometer fully clockwise. If the SPEED CONTROL potentiometer is used for both speed and

INSTRUCTION SHEET
FOR MODIFICATION A6
Sheet 1 of 3
02Y00025-0035

INTERCONNECTION DIAGRAMS

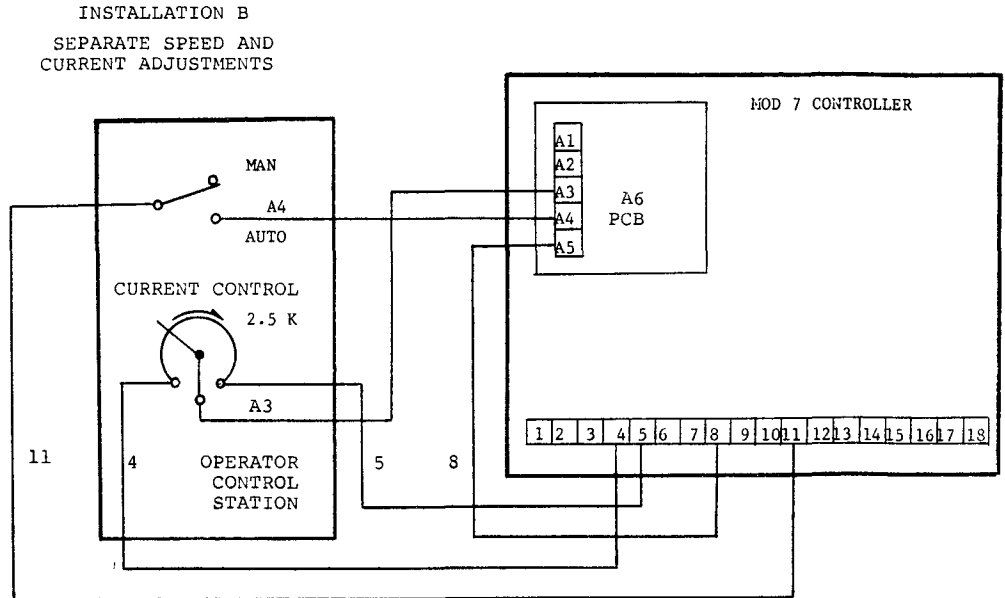
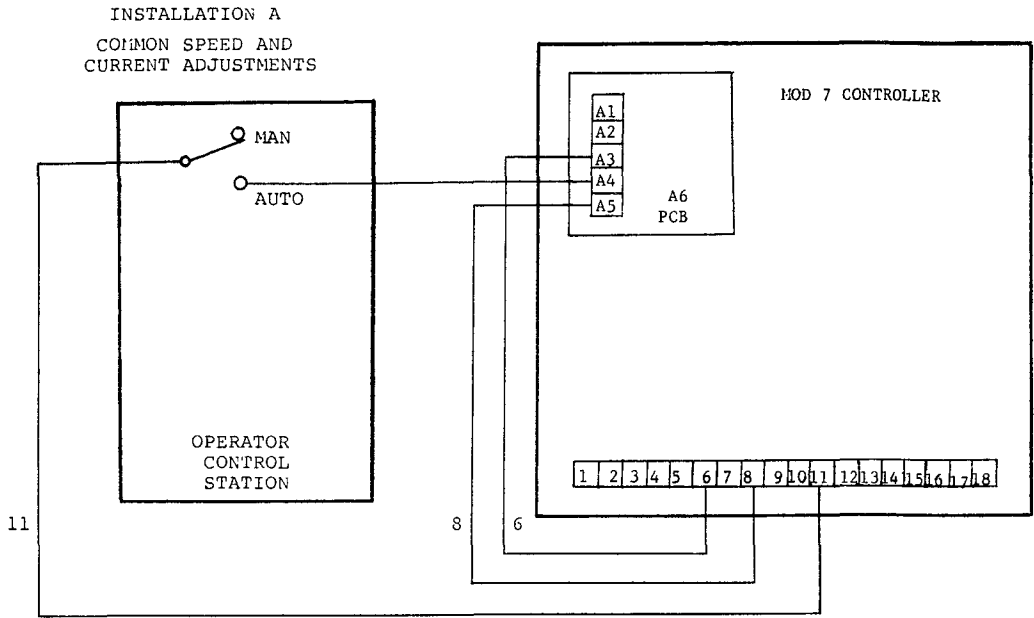

INTERCONNECTION TABLE

WIRE NO	FROM		TO		REMARKS	
	EQUIPMENT	TB OR OTHER MARKING	EQUIPMENT	TB OR OTHER MARKING		
8	Controller	TB(8)	Speed/Current Relay PCB	TB(A5)		
11	MAN/AUTO Switch	COMMON	Controller	11		
A4	Speed/Current Relay PCB A6	TB(A4)	MAN/AUTO Switch	AUTO		
INSTAL A	6	Controller	TB(6)	Speed/Current	TB(A3)	
INSTAL B	5	CURRENT CONTROL Pot	CW	Controller	TB(5)	3-Conductor Shielded Cable See Note in Controller Manual for connecting shielded cables
	4	CURRENT CONTROL Pot	CCW	Controller	TB(4)	
	A3	CURRENT CONTROL Pot	WIPER	Speed/Current Relay/PCB A6	TB(A3)	
	SHLD	Controller	TB(4)	No Connection		

- current control, turn the SPEED CONTROL potentiometer fully clockwise.
3. Adjust the TENSION SENSITIVITY potentiometer on the Regulator PCB for desired maximum clutch current.
 4. Adjust the current control or SPEED CONTROL potentiometer for desired operating clutch current.

TROUBLESHOOTING

If other mod boards have been installed, be sure to troubleshoot them thoroughly before discarding this board as faulty

Troubleshooting consists of checking the operating condition of the relay contacts.

- A. Apply AC input power to the Controller. Turn the SPEED CONTROL potentiometer fully clockwise and place the MAN/AUTO switch to MAN. Do not press RUN pushbutton.
- B. Refer to the schematic diagram of the Clutch Current/Speed PCB and check voltages between test point A1TP of the Clutch Current/Speed PCB and I2CONN(6) on the Regulator PCB. Voltage should be approximately 0 VDC. If voltage is incorrect, replace Clutch Current/Speed PCB.
- C. Press RUN pushbutton. Voltage at A1TP should go to approximately -10 VDC at a rate controlled by the ACCEL RATE potentiometer setting.
- D. Place the MAN/AUTO switch in AUTO position and adjust CURRENT CONTROL potentiometer fully clockwise. Check voltage between test point A1TP on Clutch Current/Speed PCB and I2CONN(6) of the Regulator PCB. Voltage should be approximately -10 VDC and be proportional to the CURRENT CONTROL potentiometer setting. If voltage is incorrect, replace Clutch Current/Speed PCB.

MODIFICATION RECORDS

After completing modification installation:

- A. Modify Controller identification number using Method 1 in the Controller instruction manual. Place the number "6" in the block corresponding to modification area A.
- B. Insert this instruction sheet inside the back cover of the Controller instruction manual.

MODIFICATION A8
FOR EDDY CURRENT DRIVE
(KIT P/N 46SO2051-0250)
LOG ACCEL/DECEL

Effective
11-7-80
Supersedes
7-77

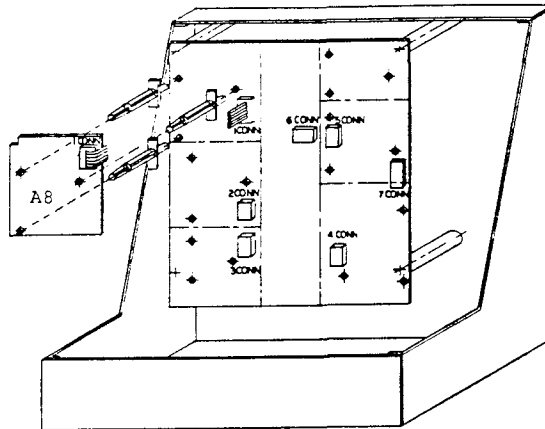

MOD PCB
46SO2085-0010
SCHEMATIC
45SO2085-0010

DESCRIPTION

This modification kit is one of a series of kits available for the Louis Allis eddy current drives. It consists of components necessary for modifying the basic Controller for the log accel/decel function. It also includes front panel nameplates and modification diagrams for the basic MOD 7 Controller instruction manual.

The addition of this assembly to the Controller enables the operator to control the acceleration and deceleration rate of a drive operating in the manual speed mode. The rate is adjustable to give an acceleration and deceleration time between 2 and 30 seconds for a 100% change in drive speed. Acceleration or deceleration is initially at a controlled rate and gradually diminishes to zero as the desired operating speed is reached. When the STOP pushbutton is pressed, the reference output of this modification will be reset to zero by a contact on the Regulator Run relay 1CR.

Input to the assembly is the Speed Reference signal from the SPEED CONTROL potentiometer or modification installed in area C or D. Output is applied to the speed regulator via any modification installed in area B.

INSTALLATION

WARNING
REMOVE ALL INPUT POWER TO DRIVE
BEFORE INSTALLING MODIFICATION KIT

This modification kit is to be installed to area A of the Regulator PCB as shown in the illustration on this page. Installation instructions are contained in the Controller instruction manual.

After installing modification, apply schematic overlay to area A of the simplified schematic diagram as described in the Controller instruction manual.

INTERCONNECTION

This modification requires no special interconnections.

Perform equipment interconnection according to the Controller instruction manual.

ADJUSTMENTS

After performing adjustments in the Controller instruction manual, adjust the modification PCB as follows.

1. Turn the ACCEL/DECEL RATE potentiometer to mid range. Turn the SPEED CONTROL to zero and start the drive.
2. Turn the SPEED CONTROL fully clockwise and observe drive acceleration rate. Adjust ACCEL/DECEL RATE potentiometer as required to obtain desired acceleration rate.
3. Turn SPEED CONTROL fully counterclockwise and verify that deceleration rate is as desired. If desired acceleration and deceleration rate cannot be obtained, perform modification kit troubleshooting procedures.

TROUBLESHOOTING

If other mod boards have been inserted, be sure to troubleshoot them thoroughly before discarding this board as faulty.

Troubleshooting consists of checking the input and output voltages of the circuit while the drive is operating.

1. Start the drive and rotate the SPEED CONTROL fully clockwise.

INSTRUCTION SHEET
FOR MODIFICATION A8

Sheet 1 of 2
02Y00025-0030

2. Refer to the schematic diagram of the Log Accel/Decel PCB and check input of the voltage between A1TP and I2CONN(6) of the Regulator PCB (common). Voltage should be approximately -10 VDC. If voltage is incorrect, refer to the troubleshooting charts in the Controller instruction manual.
3. Check output voltage between A2TP and I2CONN(6) (common). Voltage should be approximately -10 VDC after acceleration time is complete. If voltage is incorrect, replace Log Accel/Decel PCB.
4. Press STOP pushbutton and allow drive to come to a stop. Again monitor voltage at A2TP. Voltage should be -10V. If voltage is incorrect, replace Log Accel/Decel PCB.
5. Turn SPEED CONTROL fully counter clockwise and check input voltage between A1TP and I2CONN(6). Voltage should be zero to -3 VDC depending on MIN SPEED potentiometer setting. If voltage is incorrect, refer to the troubleshooting charts in the Controller instruction manual.
6. Check output voltage between A2TP and I2CONN(6). Voltage should be the same as obtained in step 5, above. Be sure DECEL time is completed. If voltage is incorrect, replace Log Accel/Decel PCB.
7. If the acceleration and deceleration rate cannot be adjusted over the proper range or operation is erratic, replace Log Accel/Decel PCB.

MODIFICATION RECORDS

After completing mod kit installation:

1. Modify Controller identification number using Method 1 in the Controller instruction manual. Place the number "8" in the block corresponding to modification area A.
2. Insert this instruction sheet inside the back cover of the Controller instruction manual.

MODIFICATION B1
FOR EDDY CURRENT DRIVE
(KIT P/N 46SO2051-0060)
VOLTAGE FOLLOWER

Effective
11-6-80
Supersedes
7-77

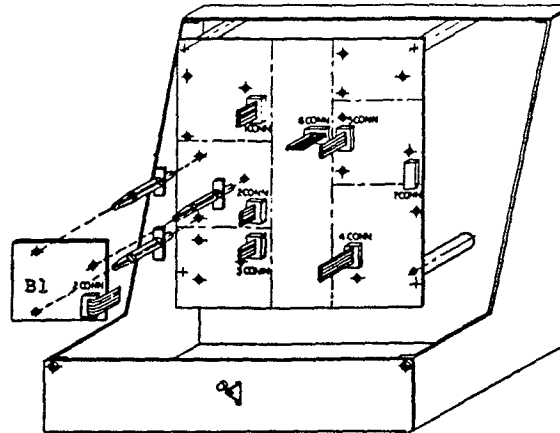

MOD PCB
46SO2044-0020
SCHEMATIC
45SO2044-0020

DESCRIPTION

This modification kit is one of a series of kits available for the Louis Allis eddy current drives. It consists of components necessary for modifying the basic Controller for a voltage follower which provides automatic drive speed control. It also includes front panel nameplates and modification diagrams for the basic MOD 7 Controller instruction manual. With this modification the drive's speed reference follows an external voltage signal at all times. An AC or DC voltage signal may be accommodated according to the connection on the terminal strip. The modification provides separate adjustments for ratio and plus/minus low speed tracking. If modification A4 (Dancer Trim) is also included on the Controller, the trim signal is also fed directly into the speed regulator and is allowed to vary the drive speed by as much as ten percent.

CAUTION

The signal input lines to this module are directly or indirectly connected to circuit common and to the 115 VAC power applied to the Controller. To prevent damage to equipment and erratic operation, be sure that the signal inputs to this module are NOT connected to earth ground nor to circuit common at any other place. An isolation transformer may be necessary either at the AC power input of the Controller or in the signal input line to avoid the application of line potentials to the following signal source.

INSTALLATION

WARNING

REMOVE ALL INPUT POWER TO DRIVE
BEFORE INSTALLING MODIFICATION
KIT.

This modification PCB is to be installed to area B of the Regulator PCB as shown in the illustration on this page. Installation instructions are contained in the Controller instruction manual.

After installing the modification PCB, apply the schematic overlay to area B of the simplified schematic diagram as described in the Controller instruction manual.

INTERCONNECTION

This modification requires an external voltage signal. Perform equipment interconnection according to the chart in the Controller instruction manual. Then connect the external voltage signal as shown in the attached interconnection diagram and table.

The allowable voltage range is 33-150 VDC (23-106 VAC). By installing a jumper between terminals B4 and B5 of the Voltage Follower PCB, a lower input voltage range of 10-53 VDC (7-37 VAC) is obtained. Loading on the external signal is 17.5K ohms on the high range and 6.2K ohms on the low range with jumper installed. For DC inputs, the positive input lead is tied to circuit common. For AC inputs, both leads must be electrically isolated from circuit common.

An external RATIO potentiometer may be remotely installed to operate in place of 1RH of the Voltage Follower PCB. This external potentiometer should be 5K ohms. Louis Allis part no. 43T00572-5023 is recommended. To install this external

INSTRUCTION SHEET
FOR MODIFICATION B1

Sheet 1 of 3
02Y00025-0007

INTERCONNECTION DIAGRAM

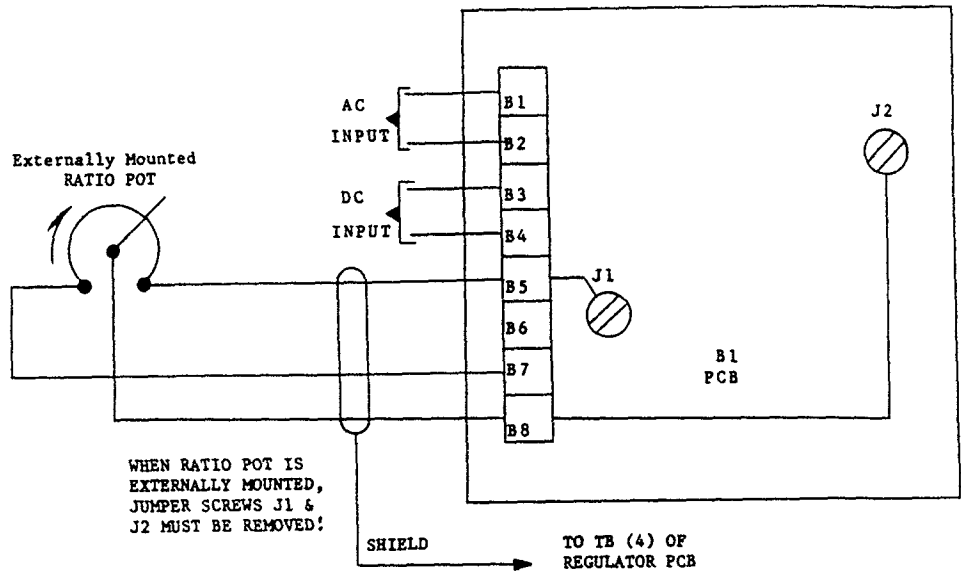

INTERCONNECTION TABLE

WIRE NO.	FROM		TO		REMARKS
	EQUIPMENT	TB OR OTHER MARKING	EQUIPMENT	TB OR OTHER MARKING	
B1	Voltage Follower PCB (B1)	TB(B1)	Customer's AC Input		
B2		TB(B2)			
B3	Voltage Follower PCB (B1)	TB(B3)	Customer's DC Input	(+)	
B4		TB(B4)		(-)	
Jumper	Voltage Follower PCB (B1)	TB(B4)	Voltage Follower PCB (B1)	TB(B5)	For 10-30 Volt Range
B5	Voltage Follower PCB (B1)	TB(B5)	External RATIO Pot	More Torque	3-Conductor shielded Cable. See Note in Controller Manual for Connecting shielded Cable.
B7		TB(B7)		Less Torque	
B8		TB(B8)		Wiper	
Shield	Regulator	TB(4)	No Connection		

potentiometer, open J1 and J2 by removing the self-tapping screws. Then wire external RATIO potentiometer according to the attached inter-connection diagram and table.

When an external RATIO potentiometer is used, remove the potentiometer knob from the RATIO potentiometer on the modification PCB.

ADJUSTMENTS

Adjust the modification PCB after performing the adjustments in the Controller instruction manual. If the MAX SPEED has not been adjusted, perform adjustment A first. If the MAX SPEED has been adjusted, proceed to adjustment B.

- A. Adjustment of MAX SPEED potentiometer with Voltage Follower (only) drives.
 1. Remove wires from modification terminals B1 through B4.
 2. Temporarily connect a wire from modification terminal B5 to terminal 5 of the Regulator PCB.
 3. Set MAX SPEED and RATIO potentiometers fully counterclockwise. Set LOW SPEED TRACKING potentiometer to mid-position.
 4. Start the drive and observe rotating unit speed. The drive should run at less than 1/3 speed.
 5. Increase the setting of the RATIO potentiometer until fully clockwise.
 6. Increase the setting of the MAX SPEED potentiometer until the drive is running at rated speed. Leave MAX SPEED at this setting.
 7. Stop drive, remove temporary wire and reconnect wires at modification terminals B1 through B4.
- B. Adjustment of modification PCB.
 1. Turn the RATIO potentiometer fully counterclockwise and the LOW SPEED TRACKING potentiometer to mid-range. Start the drive.
 2. Apply the normal minimum operating input voltage signal to the modification.
 3. Adjust the LOW SPEED TRACKING potentiometer to obtain the desired minimum drive operating speed. Range of minimum speed is $\pm 30\%$ of rated speed.
 4. Apply the normal maximum operating input voltage signal to the modification.
 5. Adjust the RATIO potentiometer clockwise until the desired maximum drive operating speed is obtained. Do not exceed the maximum drive speed rating.
 6. If desired speeds cannot be obtained, perform modification kit troubleshooting procedures.

TROUBLESHOOTING

If other mod boards have been installed be sure to troubleshoot them thoroughly before discarding this board as faulty.

Troubleshooting consists of checking the input and output voltages of the circuit while the drive is operating.

1. Start the drive.
2. Refer to the schematic diagram of the Voltage Follower PCB and check for proper input voltage between terminal connections B4(-) and B3(+) if input voltage is DC or between terminal connections B1 and B2 if input voltage is AC. If incorrect, repair or replace external voltage follower source.
3. Check that output voltage between modification test point B1TP and I2CONN(6) of the Regulator PCB (common) varies as the external signal to the follower is varied and as the RATIO potentiometer setting is varied. If not, replace the Voltage Follower PCB.

MODIFICATION RECORDS

After completing mod kit installation:

- A. Modify Controller identification number using Method 1 in the Controller instruction manual. Place the number "1" in the block corresponding to modification area B.
- B. Insert this instruction sheet to the inside back cover of the Controller instruction manual.

MODIFICATION B2
FOR EDDY CURRENT DRIVE
(KIT P/N 46SO2051-0040)
CURRENT FOLLOWER

Effective
10-6-80
Supersedes
7/77

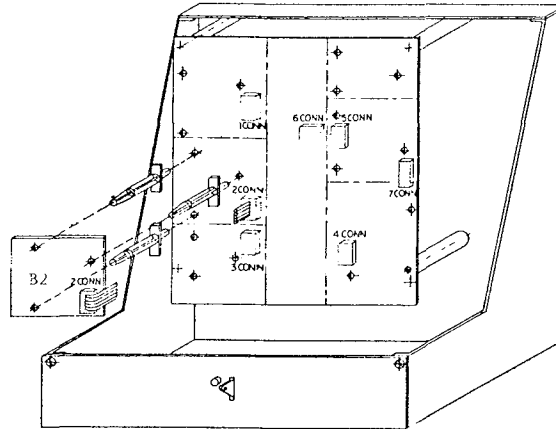

MOD PCB
46SO2043-0020
SCHEMATIC
45SO2043-0020

DESCRIPTION

This modification kit is one of a series of kits available for the Louis Allis eddy current drives. It consists of components necessary for modifying the basic Controller for automatic speed control operation. It also includes front panel nameplates and modification diagrams for the basic MOD 7 Controller instruction manual.

With this modification the drive speed is automatically controlled by an external current signal. An input DC current signal in the range of 1 to 5 milliamps is used to generate the reference voltage required by the drive. By installing jumper wires on the terminal strip, current ranges of 2 to 10, 4 to 20, and 10 to 50 milliamps can be accommodated. A RATIO potentiometer allows for an approximate -50% to +10% adjustment range. The LOW SPEED TRACKING potentiometer provides approximately +30% of rated drive speed.

The trim signal from modification A4 (Dancer Trim), if used, is also applied to the Controller. The trim signal can vary the drive speed up to 10% to maintain dancer position.

CAUTION

The signal input lines to this module are directly or indirectly connected to circuit common and to the 115 VAC power applied to the Controller. To prevent damage to the equipment and erratic operation, be sure that the signal inputs to this module are NOT connected to earth ground nor to circuit common at any other place. An isolation transformer may be necessary either at the AC power input of the Controller or in the signal input lines to avoid the application of line potentials to the follower signal source.

INSTALLATION

WARNING

REMOVE ALL INPUT POWER TO THE DRIVE
BEFORE INSTALLING MODIFICATION KIT.

This modification PCB is to be installed to area B of the Regulator PCB as shown in the illustration on this page. Installation instructions are contained in the Controller instruction manual.

After installing the modification PCB, apply the schematic overlay to area B of the simplified schematic diagram as described in the controller instruction manual.

INTERCONNECTION

This modification requires an external current signal. Perform interconnection according to the chart in the Controller instruction manual. Then connect the external current signal as shown in the attached Interconnection Table. For proper operation, the input signal should be capable of providing at least 22 volts at rated current.

An external RATIO potentiometer may be remotely installed to operate in place of 1RH of the Current Follower PCB. This external potentiometer should be 2.5K ohms. Louis Allis part no. 43T00572-2523 is recommended. To install this external potentiometer, open J1 and J2 by removing the self-tapping screws. Then wire external RATIO potentiometer according to the attached interconnection table and diagram.

When an external RATIO potentiometer is used, remove the potentiometer knob from the RATIO potentiometer on the modification PCB.

INSTRUCTION SHEET
FOR MODIFICATION B2

Sheet 1 of 3
02Y00025-0005

INTERCONNECTION DIAGRAM

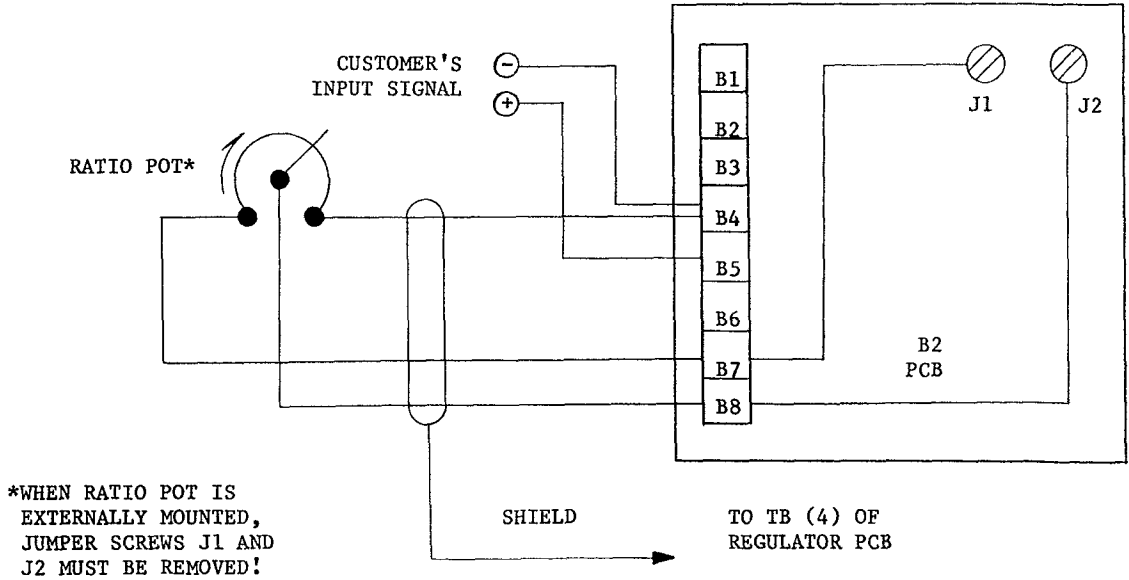

INTERCONNECTION TABLE

WIRE NO.	FROM		TO		REMARKS
	EQUIPMENT	TB OR OTHER MARKING	EQUIPMENT	TB OR OTHER MARKING	
	Current Follower PCB	TB (B4)	Customer's 5MA DC Input	(-)	
	Current Follower PCB	TB (B5)		(+)	
Jumper	Current Follower PCB	TB (B4)	Current Follower PCB	TB (B3)	Add for 10MA Range
	Current Follower PCB	TB (B4)	Current Follower PCB	TB (B2)	Add for 20MA Range
	Current Follower PCB	TB (B4)	Current Follower PCB	TB (B1)	Add for 50MA Range
B4	Current Follower PCB (B2)	TB (B4)	External RATIO Pot	More Torque	3-Conductor Shielded Cable.
B7		TB (B7)		Less Torque	
B8		TB (B8)		Wiper	
SHIELD	Regulator PCB	TB (4)	No Connection		See Note in Controller Manual for Connecting Shielded Cable.

ADJUSTMENTS

After performing the adjustments in the Controller instruction manual, adjust the modification PCB. If the MAX SPEED has not been adjusted, perform adjustment A first. If the MAX SPEED has been adjusted, proceed to adjustment B.

- A. Adjustment of MAX SPEED potentiometer with Current Follower (only) drives.
 1. Remove wires from modification terminals B1 through B5.
 2. Temporarily connect a wire from modification terminal B4 to terminal 5 of the Regulator PCB.
 3. Set MAX SPEED and RATIO potentiometers fully counterclockwise. Set LOW SPEED TRACKING potentiometer to mid-position.
 4. Start the drive and observe rotating unit speed. The drive should run at less than 1/3 speed.
 5. Increase the setting of the RATIO potentiometer until fully clockwise.
 6. Increase the setting of the MAX SPEED potentiometer until the drive is running at rated speed. Leave MAX SPEED at this setting.
 7. Stop drive, remove temporary wire and reconnect wires at modification terminals B1 through B5.
- B. Adjustment of modification PCB.
 1. Turn the RATIO potentiometer fully counterclockwise and the LOW SPEED TRACKING potentiometer to mid-range. Start the drive.
 2. Apply the normal minimum operating input current signal to the modification.
 3. Adjust the LOW SPEED TRACKING potentiometer to obtain the desired minimum drive operating speed. Range of minimum speed is $\pm 30\%$ of rated speed.
 4. Apply the normal maximum operating input current signal to the modification.
 5. Adjust the RATIO potentiometer clockwise until the desired maximum drive operating speed is obtained. Do not exceed the maximum drive speed rating.
 6. If desired speeds cannot be obtained, perform modification kit troubleshooting procedures.

TROUBLESHOOTING

Troubleshooting consists of checking the input and output voltages of the circuit while the drive is operating.

If other mod boards have been inserted, be sure to troubleshoot them thoroughly before discarding this board as faulty.

1. Start the drive.
2. Refer to the schematic diagram of the current Follower PCB and check for proper DC input current to terminal connection B4 (-). If incorrect, check jumpers or repair the external follower current source.
3. Check that output voltage between modification test point B1TP and I2CONN(6) of the Regulator PCB (common) varies as the external signal to the follower is varied and as the RATIO potentiometer setting is varied. If not, replace the Current Follower PCB.

MODIFICATION RECORDS

After completing modification installation:

- A. Modify Controller identification number using Method 1 in the Controller instruction manual. Place the number "2" in the block corresponding to modification area B.
- B. Attach this instruction sheet to the inside back cover of the Controller instruction manual.

MODIFICATION B3
FOR EDDY CURRENT DRIVE
(KIT P/N 46SO2051-0005)
VOLTAGE FOLLOWER WITH MAN/AUTO

Effective
10-6-80
Supersedes
7/77

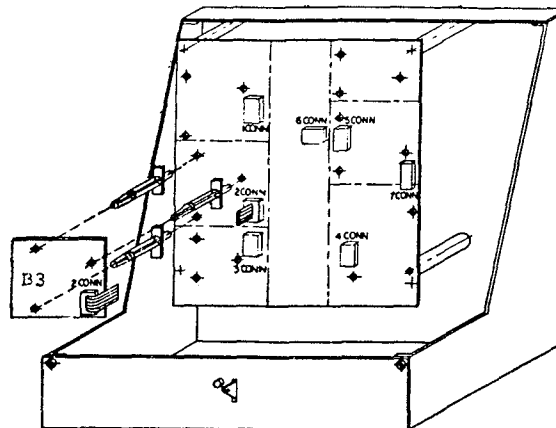

MOD PCB
46SO2044-0010
SCHEMATIC
45SO2044-0010

DESCRIPTION

This modification kit is one of a series of kits available for the Louis Allis eddy current drives. It consists of components necessary for modifying the basic Controller for a voltage follower with manual or automatic speed control. It also includes front panel nameplates and modification diagrams for the basic MOD 7 Controller instruction manual.

This modification enables the operator to control drive speed manually or automatically. In the manual speed mode (MAN/AUTO switch in MAN), the speed reference signal is supplied by the SPEED CONTROL potentiometer. In the follower speed mode (MAN/AUTO switch in AUTO), the speed reference signal follows an external voltage signal. If modification A4 (Dancer Trim) is also included on the Controller, in the follower mode the trim signal is fed directly into the speed regulator and is allowed to vary the drive speed by as much as ten percent.

CAUTION

The signal input lines to this module are directly or indirectly connected to circuit common and to the 115 VAC power applied to the controller. To prevent damage to equipment and erratic operation, be sure that the signal inputs to this module are NOT connected to earth ground nor to circuit common at any other place. An isolation transformer may be necessary either at the AC power input of the Controller or in the signal input lines to avoid the application of line potentials to the follower signal source.

INSTALLATION

WARNING

REMOVE ALL INPUT POWER TO THE DRIVE
BEFORE INSTALLING MODIFICATION KIT.

This modification kit is to be installed to area B of the Regulator PCB as shown in the illustration on this page. Installation instructions are contained in the Controller instruction manual.

After installing the modification PCB, apply one schematic overlay to area B and one schematic overlay to the upper left corner of the simplified schematic diagram as described in the Controller instruction manual.

INTERCONNECTION

This modification requires that a two position MAN/AUTO selector switch be installed to the operator control station and that an external AC or DC voltage signal be applied. Perform equipment interconnection according to the Controller instruction manual. Then perform interconnections as shown in the attached diagram and table.

The allowable input voltage range is 33-150 VDC (23-106 VAC). By installing a jumper between terminals B4 and B5 of the Voltage Follower PCB, a lower input voltage range of 10-53 VDC (7-37 VAC) is obtained. Loading on the external signal is 17.5K ohms on the high range and 6.2K ohms on the low range with jumper installed. For DC inputs, the positive input lead is tied to circuit common. For AC inputs, both leads must be electrically isolated from circuit common.

INTERCONNECTION DIAGRAM

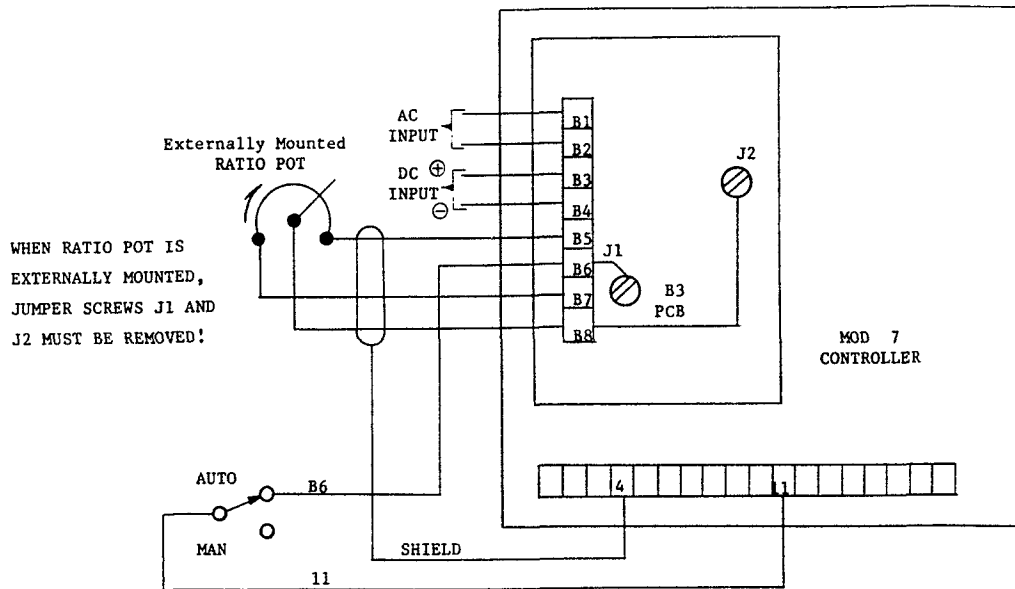

INTERCONNECTION TABLE

WIRE NO.	FROM		TO		REMARKS
	EQUIPMENT	TB OR OTHER MARKING	EQUIPMENT	TB OR OTHER MARKING	
11	Controller	TB (11)	MAN/AUTO Sw		
B6		TB (B6)	MAN/AUTO Sw	AUTO	
B1		TB (B1)	Customer's AC Input Signal		
B2	Voltage Follower With MAN/AUTO PCB	TB (B2)		(+)	
B3		TB (B3)	Customer's DC Input Signal	(-)	
B4		TB (B4)			
Jumper		TB (B4)	Voltage Follower with MAN/AUTO PCB	TB (B5)	For 10 - 30 V Range
B5	Voltage Follower with MAN/AUTO PCB (B3)	TB (B5)	External RATIO Pot	More Torque	3-Conductor Shielded Cable.
B7		TB (B7)		Less Torque	
B8		TB (B8)		Wiper	
Shield	Regulator PCB	TB (4)	No Connection		See Note in Controller Manual for Connecting Shielded Cable.

NOTE: ALL INTERCONNECTING WIRING TO BE 15 AMPS OR LESS.

An external RATIO potentiometer may be remotely installed to operate in place of 1RH of the Voltage Follower with MAN/AUTO PCB. This external potentiometer should be 5K ohms. Louis Allis part no. 43T00572-5023 is recommended. To install this external potentiometer, open J1 and J2 by removing the self-tapping screws. Then wire external RATIO potentiometer according to the attached interconnection table and diagram. When an external RATIO potentiometer is used, remove the potentiometer knob from the RATIO potentiometer on the modification PCB.

ADJUSTMENTS

After performing the adjustments in the Controller instruction manual, adjust the modification PCB as follows. It is important that the manual speed controls be adjusted before the automatic controls are adjusted.

1. Turn the RATIO potentiometer fully counter-clockwise and the LOW SPEED TRACKING potentiometer to mid-range. Start the drive.
2. Place the MAN/AUTO switch to AUTO and apply the minimum input voltage signal to the modification.
3. Adjust the LOW SPEED TRACKING potentiometer to obtain the desired minimum drive operating speed. Range of minimum speed is $\pm 30\%$ of rated speed.
4. Apply the normal maximum operating input voltage signal to the modification. Adjust the RATIO potentiometer clockwise until the desired maximum drive operating speed is obtained. Do not exceed maximum drive speed rating.
5. If desired rates cannot be obtained, perform modification kit troubleshooting procedures below.

TROUBLESHOOTING

Troubleshooting consists of checking the input and output voltages of the circuit while the drive is operating.

If other mod boards have been inserted, be sure to troubleshoot them thoroughly before discarding this board as faulty.

1. Start the drive and place the MAN/AUTO switch in AUTO.
2. Refer to the schematic diagram of the Voltage Follower with MAN/AUTO PCB and check for proper input voltage between terminal connections B3 (+) and B4 (-) if input signal is DC or between terminal connections B1 and B2 if input signal is AC. If input voltage is incorrect, repair or replace external voltage follower source.

3. Check that input voltage between B1TP and 12CONN(6) of the Regulator PCB (common) varies as the RATIO potentiometer setting is varied. If not, replace the Voltage Follower with MAN/AUTO PCB.
4. If modification A4 is installed, de-energize relay 4CR and check continuity between 2CONN(9) and 2CONN(13) using an ohmmeter. If continuity exists, replace the Voltage Follower with MAN/AUTO PCB.
5. Place the MAN/AUTO switch to MAN and check that the output voltage between B1TP and 12CONN(6) varies as the reference input signal on 2CONN(10) is varied. If not, replace the Voltage Follower with MAN/AUTO PCB.

MODIFICATION RECORDS

After completing modification installation:

- A. Modify Controller identification number using Method 1 in the Controller instruction manual. Place the number "3" in the block corresponding to modification area B.
- B. Attach this instruction sheet to the inside back cover of the Controller instruction manual.

MODIFICATION B4
FOR EDDY CURRENT DRIVE
(KIT P/N 46SO2051-0030)
CURRENT FOLLOWER WITH MAN/AUTO

Effective
11-3-80
Supersedes
7/77

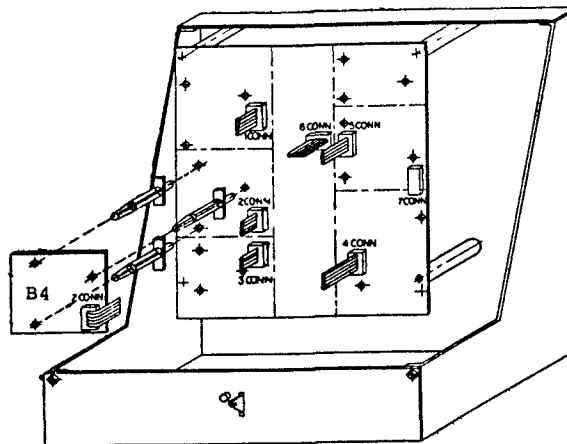

MOD PCB
46SO2043-0010
SCHEMATIC
45SO2043-0010

DESCRIPTION

This modification kit is one of a series of kits available for the Louis Allis eddy current drives. It consists of components necessary for modifying the basic Controller for a current follower with manual or automatic speed control. It also includes front panel nameplates and modification diagrams for the basic MOD 7 Controller instruction manual.

This modification enables the operator to select either the manual speed mode or follower speed mode by means of the MAN/AUTO selector switch. In the manual speed mode (MAN/AUTO switch in MAN), the speed reference signal is supplied by the SPEED CONTROL potentiometer via the Acceleration Control circuit or modification A1 or A2, if used. In the follower speed mode (MAN/AUTO switch in AUTO), the speed reference signal follows an external current signal. An input DC current signal in the range of 1 to 5 milliamps is used to generate the reference voltage required by the drive. By installing jumper wires on the terminal strip, current ranges of 2 to 10, 4 to 20 and 10 to 50 milliamps can be accommodated. A RATIO potentiometer allows for an approximate -50% to +10% adjustment range. The LOW SPEED TRACKING potentiometer provides approximately $\pm 30\%$ of rated drive speed.

In the follower speed mode the trim signal from modification A4 (Dancer Trim), if used, is also applied to the Controller. The trim signal can vary the drive speed up to ten percent to maintain dancer position.

CAUTION

The signal input lines to this module are directly or indirectly connected to circuit common and to the 115 VAC power supplied to the controller. To prevent damage to equipment and erratic operation, be sure that the signal inputs to this module are NOT connected to earth ground nor to circuit common at any other place. An isolation transformer may be necessary either at the AC power input of the Controller or in the signal input lines to avoid the application of line potentials to the follower signal source.

INSTALLATION

WARNING

REMOVE ALL INPUT POWER TO DRIVE
BEFORE INSTALLING MODIFICATION KIT.

This modification kit is to be installed to area B of the Regulator PCB as shown in the illustration on this page. Installation instructions are contained in the Controller instruction manual.

After installing the modification PCB, apply one schematic overlay to area B and one schematic overlay to the upper left corner of the simplified schematic diagram as described in the Controller instruction manual.

INSTRUCTION SHEET
FOR MODIFICATION B4

Sheet 1 of 3
02Y00025-0004

INTERCONNECTION DIAGRAM

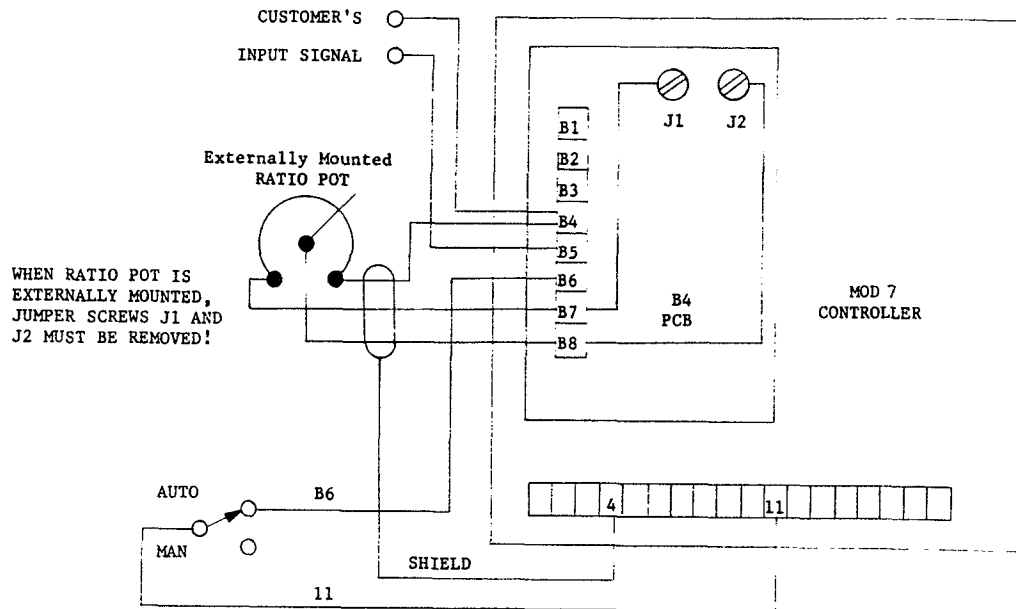

INTERCONNECTION TABLE

WIRE NO.	FROM		TO		REMARKS
	EQUIPMENT	TB OR OTHER MARKING	EQUIPMENT	TB OR OTHER MARKING	
11	Controller	TB (11)	MAN/AUTO Selector Switch		
B6		TB (B6)	MAN/AUTO Selector Switch	AUTO	
B4	Current Follower with MAN/AUTO PCB	TB (B4)	Customer's SMA Input Signal	(-)	
B5		TB (B5)		(+)	
Jumper		TB (B4)	Current Follower with MAN/AUTO PCB	TB (B3)	Add for 10MA range
Jumper		TB (B4)		TB (B2)	Add for 20MA range
Jumper		TB (B4)		TB (B1)	Add for 50MA range
B4	Current Follower with MAN/AUTO PCB (B4)	TB (B4)	External RATIO Pot	More Torque	3-Conductor Shielded Cable.
B7		TB (B7)		Less Torque	
B8		TB (B8)		Wiper	See Note in Controller Manual for Connecting Shielded Cable.
Shield	Regulator PCB	TB (4)	No Connection		

NOTE: ALL INTERCONNECTING WIRING TO BE 15 AMPS OR LESS.

INTERCONNECTION

This modification requires that a two position MAN/AUTO selector switch be installed to the operator control station and that an external DC current signal be applied. Perform equipment interconnection according to the chart in the Controller instruction manual. Then perform interconnections as shown in the attached diagram and table.

For proper operation, the external current signal should be capable of providing at least 22 volts at rated current.

An external RATIO potentiometer may be remotely installed to operate in place of LRH of the Current Follower with MAN/AUTO PCB. This external potentiometer should be 2.5K ohms. Louis Allis part no. 43T00572-2523 is recommended. To install this external potentiometer, open J1 and J2 by removing the self-tapping screws. Then wire external RATIO potentiometer according to the attached interconnection table and diagram.

When an external RATIO potentiometer is used, remove the potentiometer knob from the RATIO potentiometer on the modification PCB.

ADJUSTMENTS

After performing the adjustments in the Controller instruction manual, adjust the modification PCB as follows. It is important that the manual speed controls be adjusted before the automatic controls are adjusted.

1. Turn the RATIO potentiometer fully counter-clockwise and the LOW SPEED TRACKING potentiometer to mid-range. Start the drive.
2. Apply the normal minimum input current signal and adjust the LOW SPEED TRACKING potentiometer to obtain the desired minimum drive operating speed. Range of minimum speed is $\pm 30\%$ of rated speed.
3. Apply the normal maximum input current signal and adjust the RATIO potentiometer clockwise until the desired maximum drive operating speed is obtained. Do not exceed maximum drive speed rating.
4. If desired rates cannot be obtained, perform modification kit troubleshooting procedures.

TROUBLESHOOTING

If other mod boards have been installed, be sure to troubleshoot them thoroughly before discarding this board as faulty.

Troubleshooting consists of checking the input and output voltages of the circuit while the drive is operating.

1. Start the drive and place the MAN/AUTO switch in AUTO.
2. Refer to the schematic diagram of the Current Follower with MAN/AUTO PCB and check for proper input current to terminal connection B5 (+). If incorrect, repair or replace external follower current source.
3. Check that output voltage between B1TP and 12CONN(6) of the Regulator PCB (common) varies as the RATIO potentiometer setting is varied. If not, replace the Current Follower with MAN/AUTO PCB.
4. If modification A4 is installed, deenergize relay 4CR and check continuity between 2CONN(9) and 2CONN(13) using an ohmmeter. If continuity does not exist, replace the Current Follower with MAN/AUTO PCB.
5. Place the MAN/AUTO switch in MAN and check that the output voltage between B1TP and 12CONN(6) varies as the reference input signal to 2CONN(10) is varied. If not, replace the Current Follower with MAN/AUTO PCB.

MODIFICATION RECORDS

After completing mod kit installation:

- A. Modify Controller identification number using Method 1 in the Controller instruction manual. Place the number "4" in the block corresponding to modification area B.
- B. Insert this instruction sheet inside the back cover of the Controller instruction manual.

MODIFICATION B5
FOR EDDY CURRENT DRIVE
(KIT P/N 46SO2051-0200)
MASTER REFERENCE

Effective
2-16-81
Supersedes
7-77

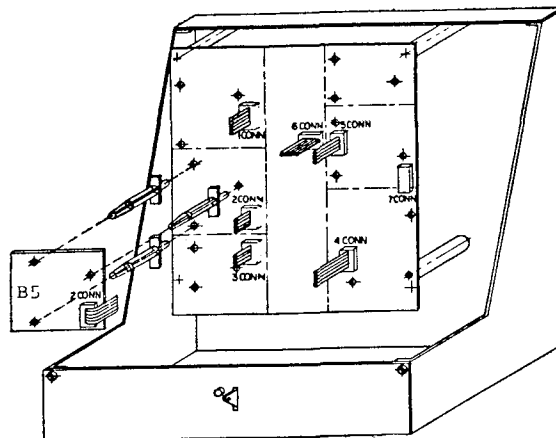

MOD PCB
46SO2052-0010
SCHEMATIC
45SO2052-0010

DESCRIPTION

This modification kit is one of a series of kits available for the Louis Allis eddy current drives. It consists of the components necessary for modifying the basic Controller for the master reference function. It also includes front panel nameplate and modification diagrams for the basic MOD 7 Controller instruction manual.

This modification provides four pairs of output terminals for the speed reference signal derived from the Acceleration Control circuit. This allows simultaneous speed control of multiple Controllers from a single speed reference. The operational amplifier LMC and transistor LTS form a voltage follower circuit with LTS acting as a current source. The output voltage at terminal board connections B2, B4, B6 and B8 is zero to -10 VDC over the speed range of the drive.

INSTALLATION

WARNING
REMOVE ALL INPUT POWER TO DRIVE BEFORE INSTALLING MODIFICATION KIT

This modification PCB is to be installed to area B of the Regulator PCB as shown in the illustration on this page. Installation instructions are contained in the Controller instruction manual.

For best drive performance, the external loading of this assembly should not exceed 20 milliamperes.

After installing modification PCB, apply the schematic overlay to area B of the simplified schematic diagram as described in the Controller instruction manual

INTERCONNECTION

Perform equipment interconnection according to the Controller instruction manual. Then connect Master Reference output terminals as shown in the Master Reference schematic diagram.

CAUTION

This modification connects the circuit common of the master drive to the circuit common of each slave drive. To prevent equipment damage, isolate each drive from the AC power line by installing an input transformer.

ADJUSTMENTS

This modification requires no special adjustments. Perform the adjustments in the Controller instruction manual.

TROUBLESHOOTING

If other mod boards have been installed, be sure to troubleshoot them thoroughly before discarding this board as faulty.

Troubleshooting consists of checking the input and output voltage of the modification while the drive is operating.

1. Start the drive and rotate SPEED CONTROL fully clockwise.
2. Refer to the schematic diagram of the Master Reference modification and check the input voltage between B1TP and 12CONN(6) of the Regulator PCB (common). Voltage should be -10 VDC.* If -10 VDC is not present, refer to the troubleshooting charts in the Controller instruction manual. (*After DECEL time has run out)

INSTRUCTION SHEET
FOR MODIFICATION B5
Sheet 1 of 2
02Y00025-0021

3. Check the output voltages between terminal board connections B2, B4, B6, B8 and 12CONN (6) of the Regulator PCB (common). Voltage should be -10 VDC. If -10 VDC is not present at any of the connections, disconnect output connections at B2, B4, B6 and B8 and recheck output voltages. If -10 VDC is not present, refer to the troubleshooting charts in the Controller instruction manual. If -10 VDC is still not present, replace Master Reference modification.

MODIFICATION RECORDS

After completing mod kit installation:

- A. Modify Controller identification number using Method 1 in the Controller instruction manual. Place the number "5" in the block corresponding to modification area B.
- B. Insert this instruction sheet inside the back cover of the Controller instruction manual.

MODIFICATION C1 JOG

KIT 46S02051-0140

PCB 46S02049-0010 SCHEMATIC 45S02049-0010

Before installing this kit, a **TECHNICALLY QUALIFIED INDIVIDUAL**, who is familiar with this type of equipment and hazards involved, should **READ** this **ENTIRE INSTRUCTION SHEET**.

IMPORTANT

This kit may have been installed by the factory. However, certain steps can only be completed at the installation site. Therefore, review and then perform those steps which complete the installation process.

DESCRIPTION

This modification kit is one of a series of kits available for the Louis Allis eddy current drives. It consists of components necessary for modifying the basic Controller for a separately adjustable jog speed of up to 25% of rated speed. It also includes front panel nameplates and modification diagrams for the basic MOD 7 Controller instruction manual.

The addition of this assembly to the Controller enables the operator to jog the drive and separately adjust the jog speed of a drive. The jog circuitry is energized when the JOG push button is pressed and held as long as the STOP push button has been pressed and any modification transfer relays are in the manual position. The jog reference bypasses any acceleration control in the

drive. When the drive is running, pressing the JOG push button will not affect drive operation.

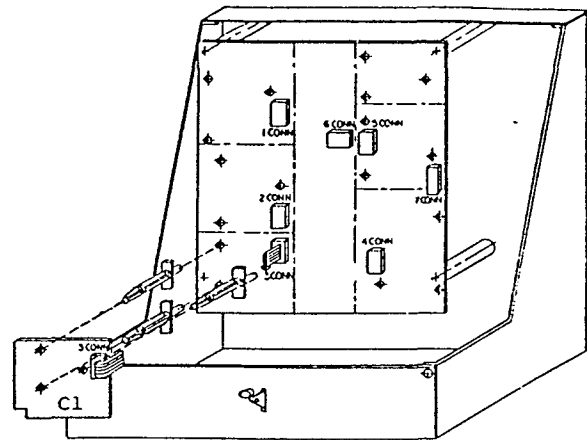

Figure 1.

INSTALLATION

WARNING

REMOVE ALL INPUT POWER TO DRIVE BEFORE INSTALLING MODIFICATION KIT.

This modification PCB is to be installed to area C of the Regulator PCB as shown in Figure 1. Installation instructions are contained in the Controller instruction manual.

After installing the modification PCB, apply the schematic overlay to area C of the simplified schematic diagram of the Controller instruction manual.

CHANGE RECORD

- REFORMAT 1/21/87

DWG. NO. 02Y00025-0015
SHEET 1 OF 3
EFF. 10/29/80 (E)

INTERCONNECTION DIAGRAM

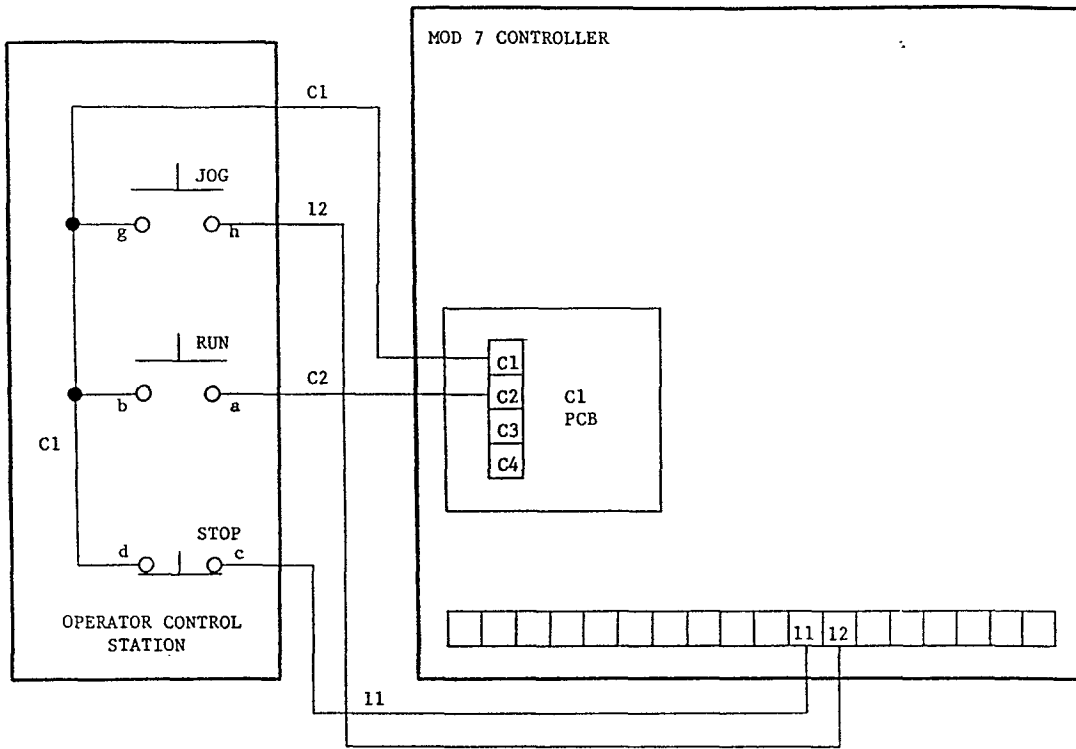

INTERCONNECTION TABLE

WIRE NO.	FROM		TO	
	EQUIPMENT	TB OR OTHER MARKING	EQUIPMENT	TB OR OTHER MARKING
11	Controller	TB (11)	STOP Button	c
12		TB (12)	JOG Button	h
C1	Jog PCB	TB (C1)	STOP Button	d
C2		TB (C2)	RUN Button	a
C1	STOP Button	d	RUN Button	b
C1		d	JOG Button	g

NOTE: THE ABOVE INTERCONNECT WIRING TO BE RATED AT 15 AMPS 115 VAC MINIMUM.

DWG. NO. 02Y00025-0015
 SHEET 2 OF 3
 EFF. 10/29/80 (E)

INTERCONNECTION

This modification requires that a normally open JOG push button be installed to the operator control station. Perform equipment interconnection according to the Controller instruction manual, but substitute wiring shown in the attached diagram and table for operator control station wiring.

NOTE

If this modification is to be used in conjunction with modification D1, Controlled Stop, refer to the D1 instruction sheet for interconnection information.

ADJUSTMENTS

After performing the adjustments in the Controller instruction manual, adjust the modification PCB as follows.

1. Press the STOP push button and stop the drive.
2. Press the JOG push button and hold. Adjust JOG SPEED potentiometer for desired speed for jog operation. If desired adjustment cannot be obtained, perform modification kit troubleshooting procedures.

TROUBLESHOOTING

If other mod boards have been installed, be sure to troubleshoot them thoroughly before discarding this board as faulty.

Troubleshooting consists of checking the input and output voltages of the circuit while the drive is being jogged.

1. Rotate JOG SPEED potentiometer fully clockwise.
2. Apply AC input power to the Controller and start the AC motor. Do not press the RUN push button.
3. Refer to the schematic diagram of the Jog PCB and check input voltage between 3CONN(10) and 12CONN(6) of Regulator PCB (common). Voltage should be approximately -10 VDC. If voltage is incorrect, remove the Jog PCB, install continuity plug and repeat voltage check. If voltage is still incorrect, refer to the troubleshooting charts in the Controller instruction manual.
4. Check voltage between C2TP and 12CONN(6). Voltage should be approximately -10 VDC and should vary with the setting of the JOG SPEED potentiometer. If voltage is incorrect, replace the Jog PCB.
5. Press the RUN push button and check the voltage between C2TP and 12CONN(6). Voltage should be zero. If voltage is incorrect, replace the Jog PCB.

MODIFICATION RECORDS

After completing mod kit installation:

- A. Modify Controller identification number using Method 1 in the Controller instruction manual. Place the number "1" in the block corresponding to modification area C.
- B. Insert this instruction sheet inside the back cover of the Controller instruction manual.

DWG. NO. 02Y00025-0015
SHEET 3 OF 3
EFF. 10/29/80 (E)

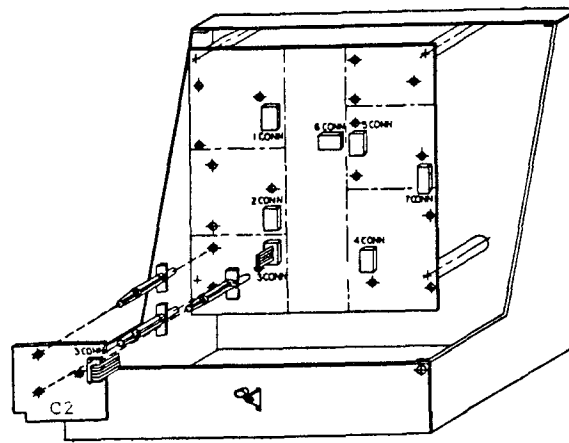

MOD PCB
46SO2049-0020
SCHEMATIC
45SO2049-0020

DESCRIPTION

This modification kit is one of a series of kits available for the Louis Allis eddy current drives. It consists of components necessary for modifying the basic Controller for the thread function. It also includes front panel nameplates and modification diagrams for the basic MOD 7 Controller instruction manual.

The addition of this modification to the Controller provides a separately adjustable thread speed of up to 30% of rated speed. With the drive stopped after the STOP pushbutton has been pressed and with any optional modification transfer relays in the manual position, pressing the THREAD pushbutton applies the thread speed reference to the Acceleration Control circuit. When the drive is running at thread speed, pressing the RUN pushbutton causes the drive to accelerate to run speed. When the drive is operating at run speed, pressing the THREAD pushbutton causes the drive to operate at thread speed. When the drive is operating at thread speed or run speed, pressing the STOP pushbutton causes the drive to stop.

INSTALLATION

WARNING
REMOVE ALL INPUT POWER TO DRIVE
BEFORE INSTALLING MODIFICATION KIT.

This modification PCB is to be installed to area C of the Regulator PCB as shown in the illustration on this page. Installation instructions are contained in the Controller instruction manual.

After installing the modification PCB, apply schematic overlay to area C of the simplified schematic diagram as described in the Controller instruction manual.

INTERCONNECTION

This modification requires that a normally open THREAD pushbutton be installed to the operator control station. Perform equipment interconnection according to the Controller instruction manual but substitute wiring in the attached diagram and table for operator control station wiring.

NOTE

If this modification is to be used in conjunction with modification D1, Controlled Stop, refer to the D1 instruction sheet for interconnection information.

ADJUSTMENTS

After performing the adjustments in the Controller instruction manual, adjust the modification PCB as follows.

1. Start the AC motor and apply AC input power to the drive.
2. Turn the THREAD SPEED potentiometer fully counterclockwise and press the THREAD pushbutton.
3. Adjust the THREAD SPEED potentiometer clockwise as required to obtain desired thread speed.
4. Turn the SPEED CONTROL potentiometer fully clockwise. Press the RUN pushbutton and note that drive accelerates to run speed.

NOTE

The thread speed setting may be affected by the ACCEL RATE Adjustment.

5. If desired rates cannot be obtained, perform modification kit troubleshooting procedures.

INSTRUCTION SHEET
FOR MODIFICATION C2

Sheet 1 of 3
02Y00025-0016

INTERCONNECTION DIAGRAM

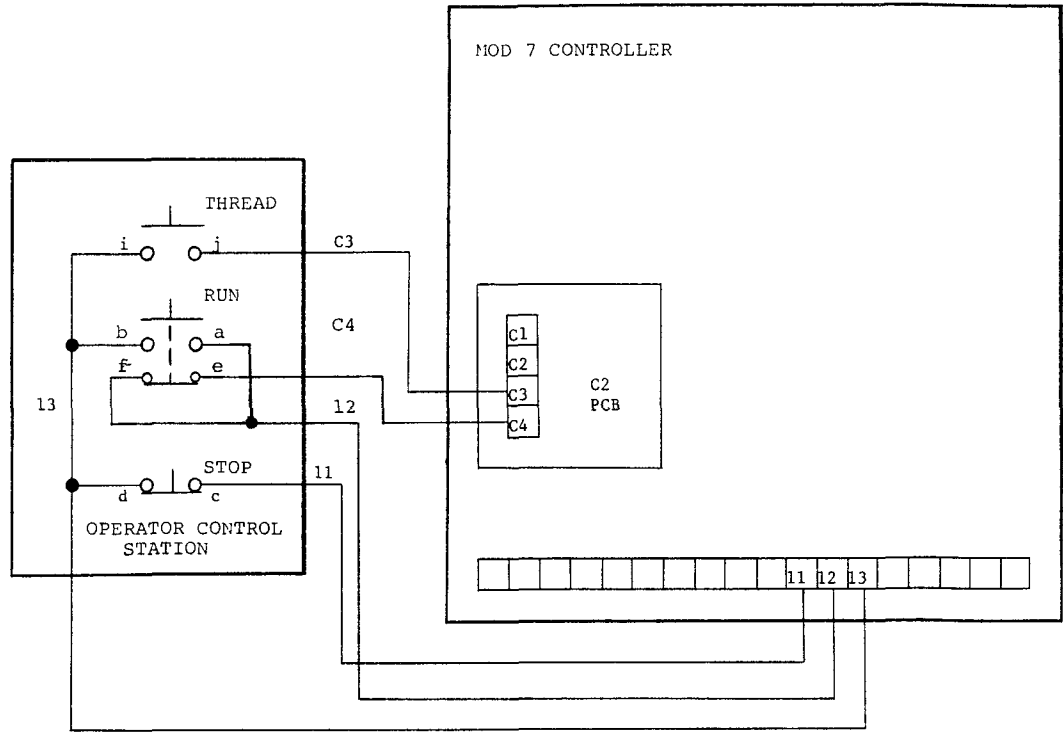

INTERCONNECTION TABLE

WIRE NO	FROM		TO	
	EQUIPMENT	TB OR OTHER MARKING	EQUIPMENT	TB OR OTHER MARKING
11	Controller	TB(11)	STOP Button	c
12	Controller	TB(12)	RUN Button	a
12	RUN Button	f	RUN Button	a
13	Controller	TB(13)	STOP Button	d
13	RUN Button	b	STOP Button	d
13	RUN Button	b	THREAD Button	i
C3	Thread PCB	TB(C3)	THREAD Button	j
C4	Thread PCB	TB(C4)	RUN Button	e

NOTE: ALL INTERCONNECTING WIRING TO BE 15 AMPS OR LESS.

TROUBLESHOOTING

If other mod boards have been installed, be sure to troubleshoot them thoroughly before discarding this board as faulty.

Troubleshooting consists of checking the input and output voltage of the circuit.

1. Rotate the THREAD SPEED potentiometer fully clockwise.
2. Start the AC motor, and apply AC input power to the Controller
3. Rotate the SPEED CONTROL fully clockwise and press the THREAD pushbutton.
4. Refer to the schematic diagram of the Thread PCB and check input voltage between 3CONN(10) and 12CONN(6) of the Regulator PCB (common). Voltage should be approximately -10 VDC. If voltage is incorrect, refer to the troubleshooting charts in the Controller instruction manual or remove the Thread PCB and repeat this check.
5. Check output voltage between C1TP and 12CONN(6). Voltage should be approximately -4 VDC and should vary with the setting of the THREAD SPEED potentiometer. If voltage is incorrect, replace Thread PCB.
6. Press RUN pushbutton and check output voltage between C1TP and 12CONN(6). Voltage should be approximately -10 VDC and vary with the setting of the SPEED CONTROL potentiometer. If voltage is incorrect, replace the Thread PCB.

MODIFICATION RECORDS

After completing mod kit installations:

- A. Modify Controller identification number using Method 1 in the Controller instruction manual. Place the number "2" in the block corresponding to modification area C.
- B. Insert this instruction sheet inside the back cover of the Controller instruction manual.

MODIFICATION C3
FOR EDDY CURRENT DRIVE
(KIT P/N 46SO2051-0160)
JOG, THREAD

Effective
11-12-80
Supersedes
7-77

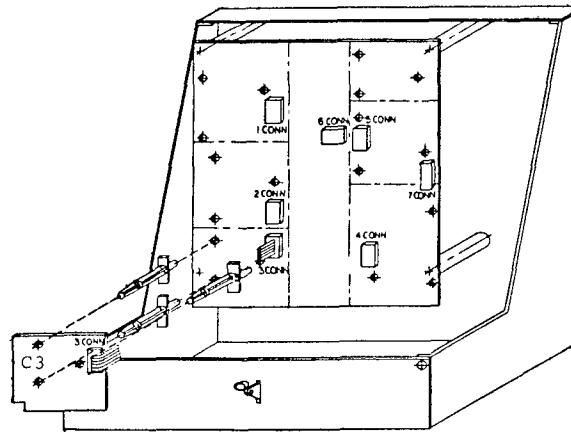

MOD PCB
46SO2049-0030
SCHEMATIC
45SO2049-0030

DESCRIPTION

This modification kit is one of a series of kits available for the Louis Allis eddy current drives. It consists of components necessary for modifying the basic Controller for the jog and thread functions. It also includes front panel nameplates and modification diagrams for the basic MOD 7 Controller instruction manual.

The addition of this assembly to the Controller enables the operator to separately adjust the jog and thread speeds of the drive. The jog speed and the thread speed is adjustable to 30%.

The jog circuit is energized by pressing and holding the JOG pushbutton as long as the STOP pushbutton has previously been pressed and any modification transfer relays are in the manual position. The jog reference signal bypasses the Acceleration Control circuit. If the drive is running, pressing the JOG pushbutton will not affect system operation.

The thread circuit is energized by pressing the THREAD pushbutton as long as any modification transfer relays are in manual. The thread reference speed signal is applied to the acceleration control circuit. With the drive operating in thread speed, pressing the RUN pushbutton will cause the speed reference to automatically accelerate to run speed. If the drive is running, pressing the THREAD pushbutton causes the drive to run at thread speed.

INSTALLATION

WARNING
REMOVE ALL INPUT POWER TO DRIVE BEFORE INSTALLING MODIFICATION KIT

This modification PCB is to be installed to area C of the Regulator PCB as shown in the illustration on this page. Installation instructions are contained in the Controller instruction manual.

After installing the modification PCB, apply the schematic overlay to area C of the simplified schematic diagram of the Controller instruction manual.

INTERCONNECTION

This modification requires that a normally open JOG pushbutton and a normally open THREAD pushbutton be installed to the operator control station. Perform equipment interconnection according to the Controller instruction manual, but substitute the wiring in the attached diagram and table for operator control station wiring.

NOTE

If this modification kit is to be used in conjunction with modification D1, Controlled Stop, refer to the D1 instruction information.

ADJUSTMENTS

After performing the adjustments in the Controller instruction manual, adjust the modification PCB as follows:

1. Apply AC input power to the Controller and start the AC motor.
2. Press the JOG pushbutton and hold while adjusting the JOG SPEED potentiometer for the desired jog speed.
3. Press the THREAD pushbutton and adjust the THREAD SPEED potentiometer for the desired thread speed.

INSTRUCTION SHEET
FOR MODIFICATION C3

Sheet 1 of 3
02Y00025-0017

INTERCONNECTION DIAGRAM

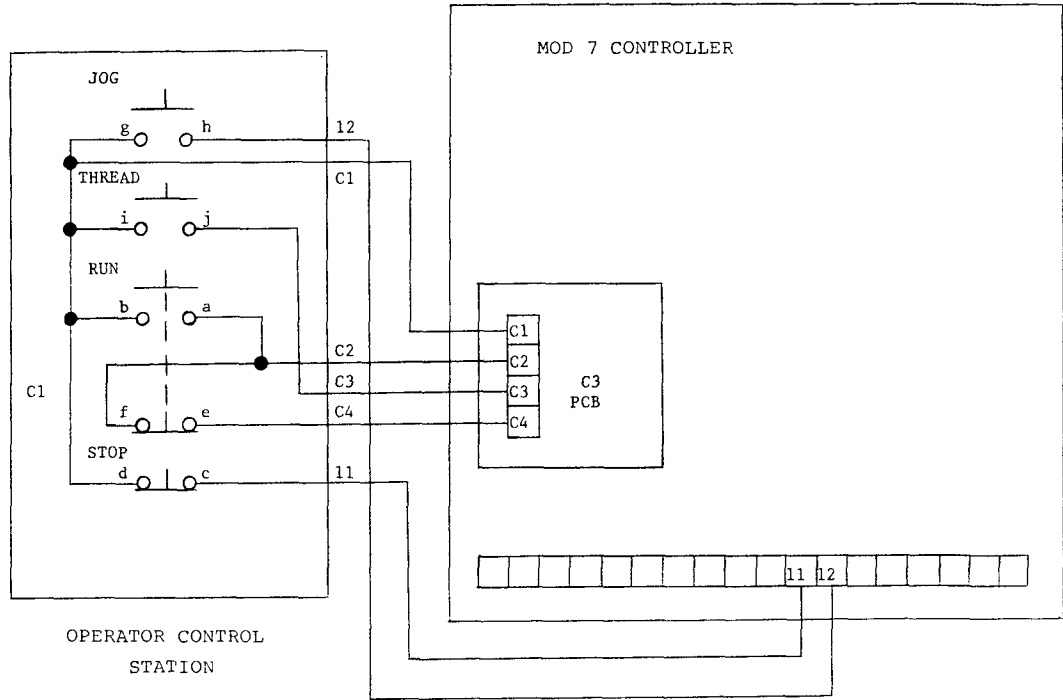

INTERCONNECTION TABLE

WIRE NO.	FROM		TO	
	EQUIPMENT	TB OR OTHER MARKING	EQUIPMENT	TB OR OTHER MARKING
11	Controller	TB(11)	STOP Button	c
12	JOG Button	h	Controller	TB(12)
C1	RUN Button	b (N.O.)	STOP Button	d
C2	RUN Button	a (N.O.)	Jog, Thread PCB (C3)	TB(C2)
C1	JOG Button	g	STOP Button	d
C1	STOP Button	d	Jog, Thread PCB (C3)	TB(C1)
C1	STOP Button	d	THREAD Button	i
C3	THREAD Button	j	Jog, Thread PCB (C3)	TB(C3)
C2	Jog, Thread PCB (C3)	TB(C2)	RUN Button	f (N.C.)
C4	Jog, Thread PCB (C3)	TB(C4)	RUN Button	e (N.C.)

NOTE: ALL INTERCONNECTING WIRING TO BE 15 AMPS OR LESS

4. If these adjustments do not permit proper operation of the drive, perform modification kit troubleshooting procedure.

TROUBLESHOOTING

If other mod boards have been installed, be sure to troubleshoot them thoroughly before discarding this board as faulty.

Troubleshooting consists of checking the input and output voltages of the circuit while the drive is operating.

1. Rotate the JOG SPEED, THREAD SPEED and SPEED CONTROL potentiometers fully clockwise.
2. Apply AC input power to the Controller and start the AC motor.
3. Refer to the schematic diagram of the Jog, Thread PCB and check input voltage between 3CONN(10) and 12CONN(6) of the Regulator PCB (common). Voltage should be -10 VDC. If voltage is incorrect, refer to the troubleshooting charts in the Controller instruction manual or remove the Jog, Thread PCB and repeat voltage check.
4. Press and hold the JOG pushbutton and check the voltage between C2TP and 12CONN(6). Voltage should be -10 VDC and should vary with the setting of the JOG SPEED potentiometer. If voltage is incorrect, replace the Jog, Thread PCB.
5. With the JOG pushbutton pressed and held, check the voltage between 3CONN(12) and 12CONN(6). Voltage should be zero. If voltage is incorrect, replace the Jog, Thread PCB.
6. Press the THREAD pushbutton and check voltage between C1TP and 12CONN(6). Voltage should be approximately -4 VDC and should vary with the setting of the THREAD potentiometer. If voltage is incorrect, replace the Jog, Thread PCB.
7. Press the RUN pushbutton and check the voltage between C1TP and 12CONN(6). Voltage should be approximately -10 VDC and should vary with the setting of the SPEED CONTROL potentiometer. If voltage is incorrect, replace the Jog, Thread PCB.

MODIFICATION RECORDS

After completing mod kit installation:

- A. Modify Controller identification number using Method 1 in the Controller instruction manual. Place the number "3" in the block corresponding to modification area C.
- B. Insert this instruction sheet inside the back cover of the Controller instruction manual.

MODIFICATION C4
FOR EDDY CURRENT DRIVE
(KIT P/N 46SO2051-0410)
THREAD, REMOTE ADJUST

Effective
2-9-81
Supersedes
12-78

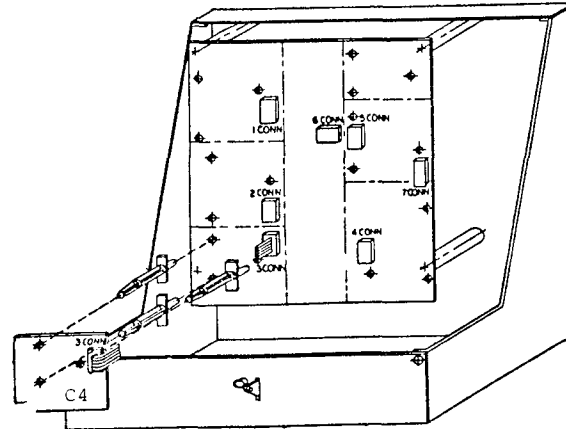

MOD PCB
46SO2138-0010
SCHEMATIC
45SO2138-0010

DESCRIPTION

This modification kit is one of a series of kits available for the Louis Allis eddy current drives. It consists of components necessary for modifying the basic Controller for the thread function. It also includes front panel nameplates and modification diagrams for the basic MOD 7 Controller instruction manual.

The addition of this modification to the Controller provides a separately adjustable thread speed of up to 30% of rated speed. With the drive stopped after the STOP pushbutton has been pressed and with any optional modification transfer relays in the manual position, pressing the THREAD pushbutton applies the thread speed reference to the Acceleration Control circuit. When the drive is running at thread speed, pressing the RUN pushbutton causes the drive to accelerate to run speed. When the drive is operating at run speed, pressing the THREAD pushbutton causes the drive to operate at thread speed. When the drive is operating at thread speed or run speed, pressing the STOP pushbutton causes the drive to stop.

INSTALLATION

WARNING
REMOVE ALL INPUT POWER TO DRIVE BEFORE INSTALLING MODIFICATION KIT

This modification PCB is to be installed to area C of the Regulator PCB as shown in the illustration on this page. Installation instructions are contained in the Controller instruction manual.

This kit differs from thread mod kit C2 in that the THREAD SPEED pot is externally mounted. It may be placed with the operator controls or remotely located as suitable.

After installing the modification PCB, apply schematic overlay to area C of the simplified schematic diagram as described in the Controller instruction manual.

INTERCONNECTION

This modification requires that a normally open THREAD pushbutton be installed in the operator control station, and a THREAD SPEED potentiometer be installed where desired. Perform equipment interconnection according to the Controller manual, but substitute the wiring in the attached diagram and table for operator control station wiring.

ADJUSTMENTS

After performing the adjustments in the Controller instruction manual, adjust the modification PCB as follows.

1. Start the AC motor and apply AC input power to the drive.
2. Turn the THREAD SPEED potentiometer fully counterclockwise and press the THREAD pushbutton.
3. Adjust the THREAD SPEED potentiometer clockwise as required to obtain desired thread speed.
4. Turn the SPEED CONTROL potentiometer fully clockwise. Press the RUN pushbutton and note that drive accelerates to run speed.

NOTE

The thread speed setting may be affected by the ACCEL RATE adjustment.

5. If desired rates cannot be obtained, perform modification kit troubleshooting procedures.

TROUBLESHOOTING

If other mod boards have been installed, be sure to troubleshoot them thoroughly before discarding this board as faulty.

INSTRUCTION SHEET
FOR MODIFICATION C4
Sheet 1 of 3
02Y00025-0037

INTERCONNECTION DIAGRAM

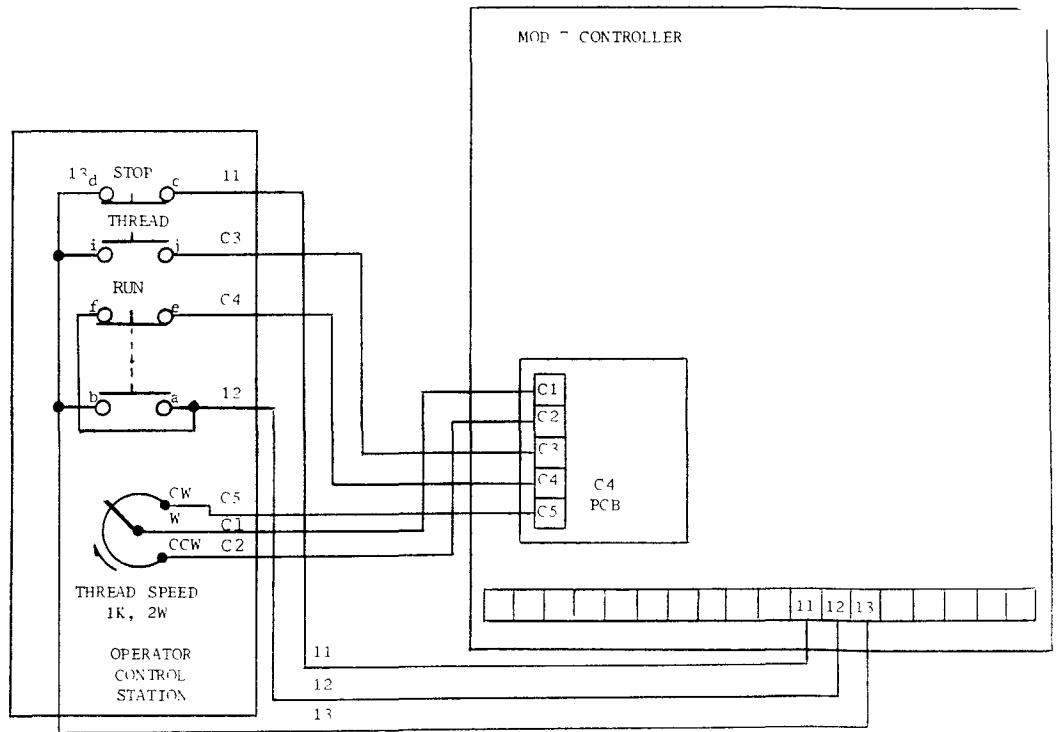

INTERCONNECTION TABLE

WIRE NO	FROM		TO	
	EQUIPMENT	TB OR OTHER MARKING	EQUIPMENT	TB OR OTHER MARKING
11	Controller	TB(11)	STOP Button	c
12	Controller	TB(12)	RUN Button	a
12	RUN Button	f	RUN Button	a
13	Controller	TB(13)	STOP Button	d
13	RUN Button	b	STOP Button	d
13	RUN Button	b	THREAD Button	i
C1	Thread PCB	TB(C1)	SPEED Pot	Wiper
C2	Thread PCB	TB(C2)	SPEED Pot	CCW
C3	Thread PCB	TB(C3)	THREAD Button	j
C4	Thread PCB	TB(C4)	RUN Button	e
C5	Thread PCB	TB(C5)	SPEED Pot	CW

NOTE: ALL INTERCONNECTING WIRING TO BE 15 AMPS OR LESS

Troubleshooting consists of checking the input and output voltage of the circuit

1. Rotate the THREAD SPEED potentiometer fully clockwise
2. Start the AC motor, and apply AC input power to the Controller
3. Rotate the SPEED control fully clockwise and press the THREAD pushbutton
4. Refer to the schematic diagram of the Thread PCB and check input voltage between 3CONN(10) and 12CONN(6) of the Regulator PCB (common) Voltage should be approximately -10 VDC If voltage is incorrect, refer to the troubleshooting charts in the Controller instruction manual, or remove the Thread PCB and repeat this check.
5. Check output voltage between C1TP and 12CONN(6). Voltage should be approximately -4 VDC, and should vary with the setting of the THREAD SPEED potentiometer If voltage is incorrect, replace Thread PCB.
6. Press RUN pushbutton and check output voltage between C1TP and 12CONN(6). The voltage should be approximately -10 VDC and vary with the setting of the SPEED CONTROL potentiometer If the Voltage is incorrect, replace the Thread PCB.

MODIFICATION RECORDS

After completing mod kit installation:

- A. Modify Controller identification number using Method 1 in the Controller instruction manual. Place the number "4" in the block corresponding to modification area C
- B. Insert this instruction sheet inside the back cover of the Controller instruction manual.

MODIFICATION D1
FOR EDDY CURRENT DRIVE
(KIT P/N 46SO2051-0090)
CONTROLLED STOP

Effective
2-10-61
Supersedes
7-77

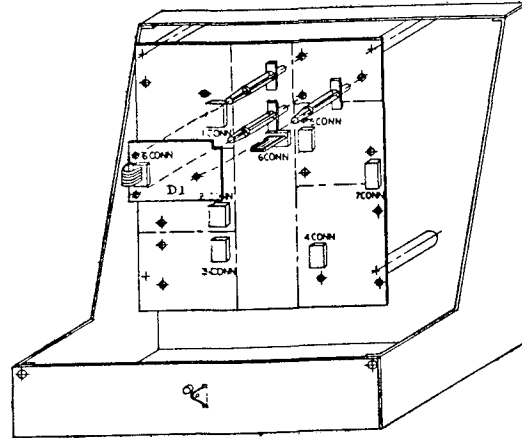

MOD PCB
46SO2047-0010
SCHEMATIC
45SO2047-0010

DESCRIPTION

This modification kit is one of a series of kits available for the Louis Allis eddy current drives. It consists of components necessary for modifying the basic controller for the controlled stop function. It also includes front panel nameplates and modification diagrams for the basic MOD 7 Controller instruction manual.

This modification should be used in conjunction with a Linear Accel/Decel modification A1 or A2. The modification consists of an auxiliary relay for holding in the run circuit and an electronically operated relay for monitoring the tachometer signal. When the STOP pushbutton is pressed, the drive linearly decelerates from run speed (or thread speed if so equipped) to a preset low speed where the tachometer sensitive relay trips and the drive is braked to a stop. The low speed trip point can be adjusted from zero to approximately 30% of rated drive speed.

If an optional EMERGENCY STOP pushbutton is pressed, the Controlled Stop circuit is bypassed, and the drive stops immediately.

If a Jog modification is installed, the Controlled Stop modification does not operate during jogging. If a Thread modification is installed, the Controlled Stop modification will operate from thread speed.

INSTALLATION:

WARNING
REMOVE ALL INPUT POWER TO DRIVE BEFORE INSTALLING MODIFICATION KIT

This modification PCB is to be installed to area D of the Regulator PCB as shown in the illustration on this page. Installation instructions are contained in the Controller instruction manual.

After installing the modification PCB, apply the schematic overlay to area D of the simplified schematic diagram as described in the Controller instruction manual. If this modification is installed in conjunction with Jog C1, Thread C2 or Jog and Thread C3 modification, there is a C1-D1, C2-D1, or C3-D1 schematic overlay which incorporates the combination of modifications. The applicable overlay is to be placed over modification areas C and D and surrounding area as indicated by corner marks.

Schematic overlays which are not used should be retained for possible future use.

INTERCONNECTION

Separate interconnection procedures are provided for the Controlled Stop modification used alone or in conjunction with a Jog or Thread modification. Select the procedure which applies to the particular application.

ADJUSTMENTS

After performing the adjustments in the Controller instruction manual, adjust the modification PCB as follows.

1. Turn the TRIP SPEED potentiometer to mid-range, turn the SPEED CONTROL to zero, and start the drive.
2. Turn the SPEED CONTROL fully clockwise. Press the STOP pushbutton and note the low speed trip point. The trip point is the speed at which the brake is energized.
3. Adjust the TRIP SPEED potentiometer as required to obtain desired low speed trip point. Turning the potentiometer clockwise causes trip at higher speed.
4. If desired rates cannot be obtained, perform modification kit troubleshooting procedures.

INSTRUCTION SHEET
FOR MODIFICATION D1
Sheet 1 of 6
02Y00025-0010

INTERCONNECTION DIAGRAM AND TABLE

CONTROLLER STOP D1

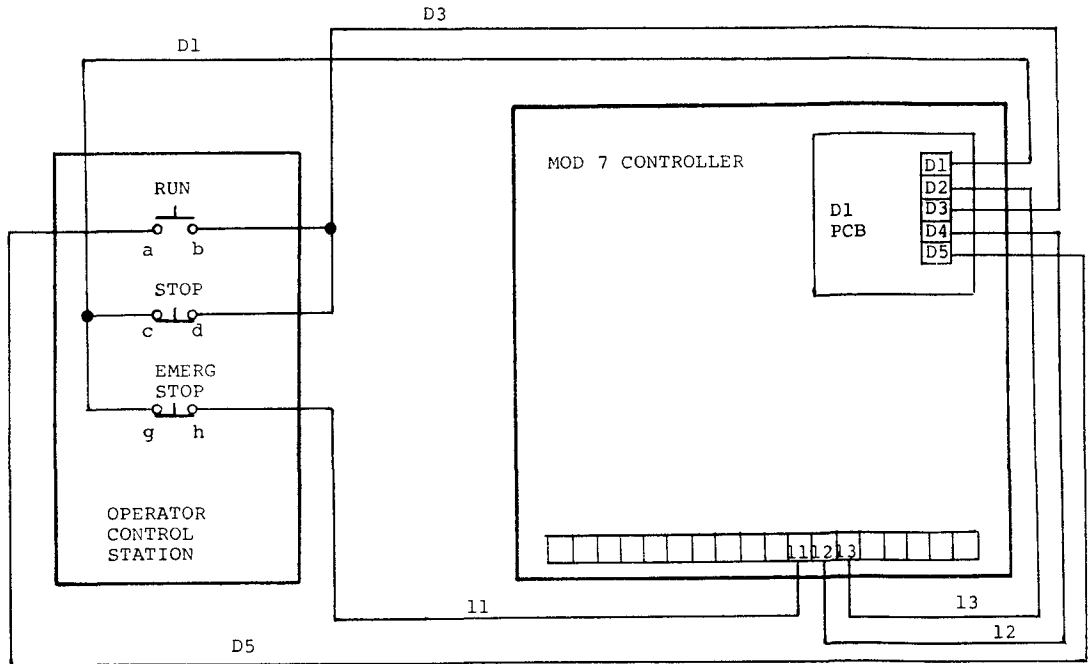

WIRE NO	FROM		TO	
	EQUIPMENT	TB OR OTHER MARKING	EQUIPMENT	TB OR OTHER MARKING
11	Controller	TB (11)	EMERG STOP Button	h
12	Controller	TB (12)	Controlled Stop PCB	TB (D4)
13	Controller	TB (13)	Controlled Stop PCB	TB (D2)
D1	Controlled Stop PCB	TB (D1)	STOP Button	c
D1	STOP Button	c	EMERG STOP Button	g
D3	Controlled Stop PCB	TB (D3)	STOP Button	d
D3	STOP Button	d	RUN Button	b
D5	Controlled	TB (D5)	RUN Button	a

A. Controlled Stop without Jog or Thread

This modification requires that a normally closed EMERGENCY STOP pushbutton be installed to the operator control station. Perform equipment interconnection according to the Controller instruction manual but substitute wiring in the diagram and table above for operator control station wiring.

INTERCONNECTION DIAGRAM AND TABLE
CONTROLLED STOP WITH JOG C1-D1

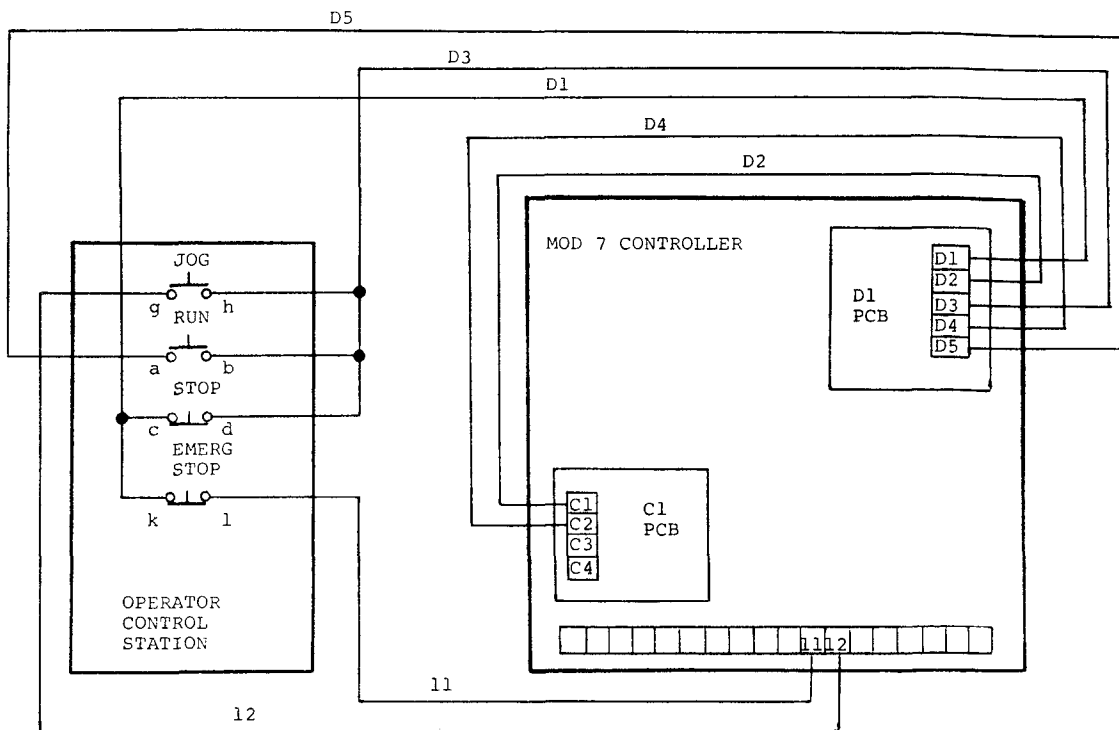

WIRE NO	FROM		TO	
	EQUIPMENT	TB OR OTHER MARKING	EQUIPMENT	TB OR OTHER MARKING
11	Controller	TB (11)	EMERG STOP Button	1
12	Controller	TB (12)	JOG Button	g
D1	Controlled Stop PCB	TB (D1)	STOP Button	c
D1	STOP Button	c	EMERG STOP Button	k
D3	Controlled Stop PCB	TB (D3)	JOG Button	h
D3	JOG Button	h	RUN Button	b
D3	RUN Button	b	STOP Button	d
D5	Controlled Stop PCB	TB (D5)	RUN Button	a
D2	Controlled Stop PCB	TB (D2)	Jog PCB	TB (C1)
D4	Controlled Stop PCB	TB (D4)	Jog PCB	TB (C2)

B. Controlled Stop with Jog C1

This modification requires that a normally closed EMERGENCY STOP pushbutton and a normally open JOG pushbutton can be installed to the operator control station. Perform equipment interconnection according to the Controller instruction manual but substitute wiring in the diagram and table above for operator control station wiring.

INTERCONNECTION DIAGRAM AND TABLE
CONTROLLED STOP WITH THREAD C2-D1

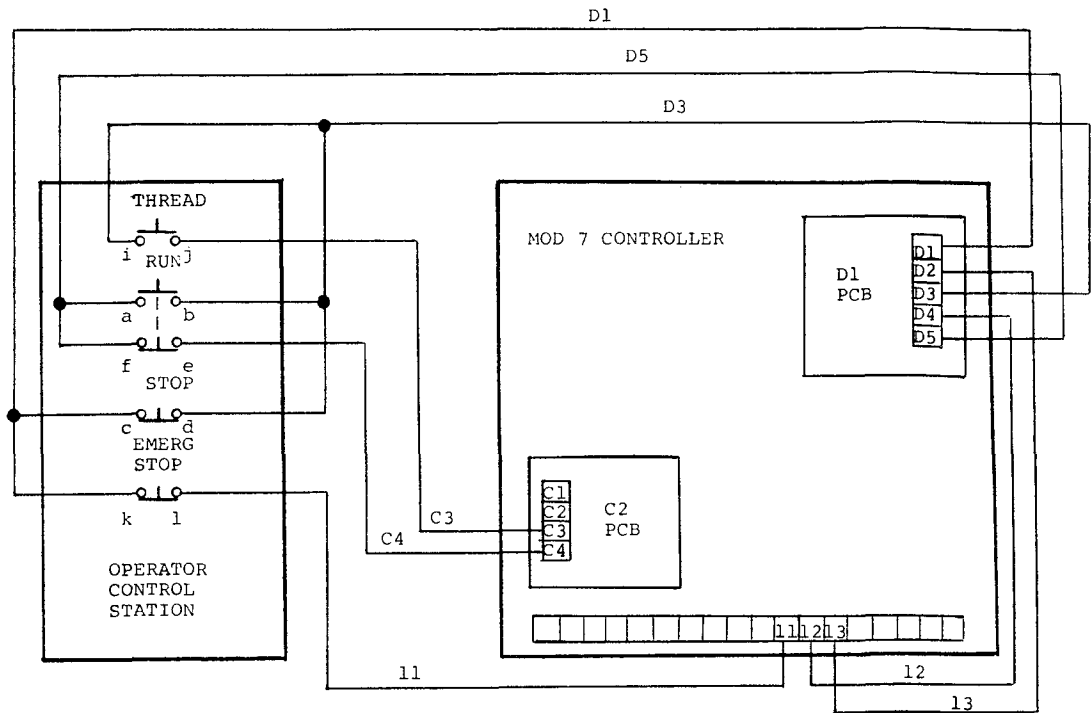

WIRE NO	FROM		TO	
	EQUIPMENT	TB OR OTHER MARKING	EQUIPMENT	TB OR OTHER MARKING
11	Controller	TB (11)	EMERG STOP Button	1
12	Controller	TB (12)	Controlled Stop PCB	TB (D4)
13	Controller	TB (13)	Controlled Stop PCB	TB (D2)
D1	Controlled Stop PCB	TB (D1)	STOP Button	c
D1	EMERG STOP Button	k	STOP Button	c
D3	Controlled STOP PCB	TB (D3)	THREAD Button	i
D3	RUN Button	b	THREAD Button	i
D5	RUN Button	a	RUN Button	f
D3	RUN Button	b	STOP Button	d
D5	Controlled	TB (D5)	RUN Button	a
C3	Thread PCB	TB (C3)	THREAD Button	j
C4	Thread PCB	TB (C4)	RUN Button	e

C Controlled Stop with Thread C2

This modification requires that a normally closed EMERGENCY STOP pushbutton and a normally open THREAD pushbutton be installed to the operator control station. Perform equipment interconnection according to the Controller instruction manual but substitute wiring in the diagram and table above for operator control station wiring

INTERCONNECTION DIAGRAM AND TABLE
CONTROLLED STOP WITH JOG, THREAD C3-D1

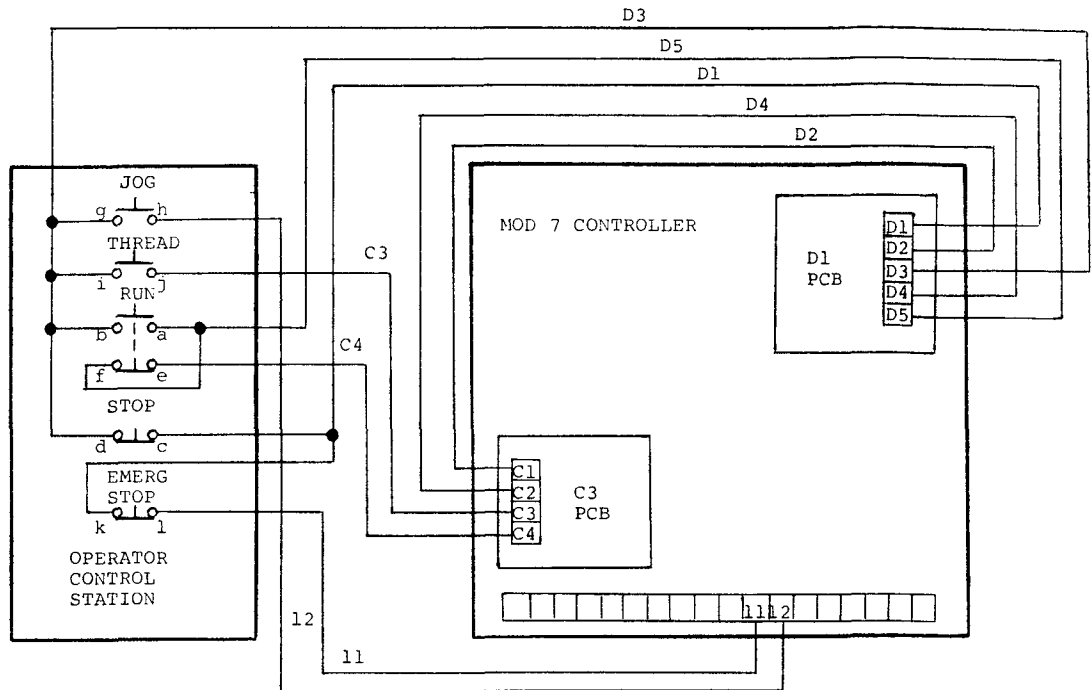

WIRE NO	FROM		TO	
	EQUIPMENT	TB OR OTHER MARKING	EQUIPMENT	TB OR OTHER MARKING
11	Controller	TB(11)	EMERG STOP Button	1
12	Controller	TB(12)	JOG Button	h
D1	Controlled Stop PCB	TB(D1)	STOP Button	c
D1	EMERG STOP Button	k	STOP Button	c
D3	Controlled Stop PCB	TB(D3)	JOG Button	g
D3	THREAD Button	i	Jog Button	g
D3	THREAD Button	i	RUN Button	b
D3	STOP Button	d	RUN Button	b
D5	Controlled Stop PCB	TB(D5)	RUN Button	a
D5	RUN Button	f	RUN Button	a
D2	Controlled	TB(D2)	Jog, Thread PCB	TB(C1)
D4	Controlled Stop PCB	TB(D4)	Jog, Thread PCB	TB(C2)
C3	THREAD Button	j	Jog, Thread PCB	TB(C3)
C4	RUN Button	e	Jog, Thread PCB	TB(C4)

D Controlled Stop with Jog and Thread C3

This modification requires that a normally open JOG pushbutton, normally open THREAD pushbutton and normally closed EMERGENCY STOP pushbutton be installed to the operator control station. Perform equipment interconnection according to the Controller instruction manual but substitute wiring in the diagram and table above for operator control station wiring.

TROUBLESHOOTING

If other mod boards have been installed, be sure to troubleshoot them thoroughly before discarding this board as faulty.

Troubleshooting consists of checking the input and output voltages of the circuit.

1. If brake is applied prematurely or does not come on at all, check the TRIP SPEED adjustment.
2. Apply AC input power to the Controller and press the RUN pushbutton. Rotate the SPEED Control potentiometer fully clockwise.
3. Refer to the schematic diagram of the Controlled Stop PCB and check contacts of 7CR as follows:
 - a. Between D5 and D3, voltage is zero when RUN or THREAD pushbutton is pressed.
 - b. Between D2 and D4, voltage is zero when RUN or JOG pushbutton is pressed.
 - c. Between 6CONN(10) and D1TP, voltage is zero.

If any of the above conditions (when applicable) is not met, replace the Controlled Stop PCB.

4. Check input voltage between 6CONN(1) and 12CONN(6) of the Regulator PCB (common). Voltage should be approximately +10 VDC at rated speed and should vary with drive speed. If voltage is incorrect, refer to the troubleshooting charts in the Controller instruction manual.
5. Check output voltage between D1TP and 12CONN(6) (common). Voltage should be approximately -10 VDC and should vary with the setting of the SPEED CONTROL potentiometer. If voltage is incorrect, check for faults in the speed control circuitry or replace the Controlled Stop PCB.
6. Press the STOP pushbutton. Voltage between D1TP and 12CONN(6) (common) should be zero VDC. If not, replace the Controlled Stop PCB.
7. With the STOP pushbutton pressed, check contacts of 6CR as follows:
 - a. Turn TRIP SPEED potentiometer fully counterclockwise. Voltage between D2 and D1 should be an AC voltage.
 - b. Turn TRIP SPEED potentiometer fully clockwise. Voltage between D2 and D1 should be 0 VAC.

If either condition is not met, replace Controlled Stop PCB.

MODIFICATION RECORDS

After completing mod kit installation:

- A. Modify Controller identification number using Method 1 in the Controller instruction manual. Place the number "1" in the block corresponding to modification area D.

- B. Insert this instruction sheet inside the back cover of the Controller instruction manual.

MODIFICATION D2
FOR EDDY CURRENT DRIVE
(KIT P/N 46SO2051-0100)
ADJUSTABLE SPEED TRIP

Effective
2-6-81
Supersedes
7-77

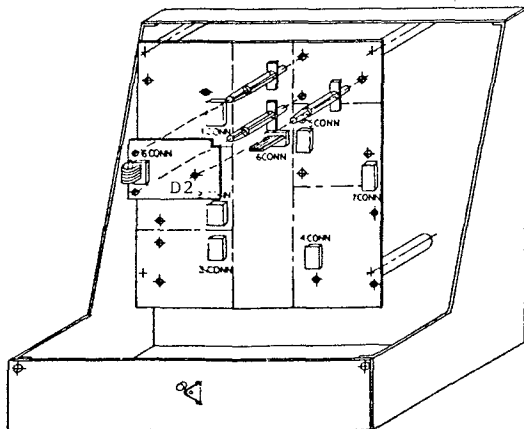

MOD PCB
46SO2047-0020
SCHEMATIC
45SO2047-0020

DESCRIPTION

This modification kit is one of a series of kits available for the Louis Allis eddy current drives. It consists of components necessary for modifying the basic Controller for the adjustable speed trip function. It also includes front panel nameplates and modification diagrams for the basic MOD 7 Controller instruction manual.

This modification consists of an electronically operated relay which monitors the tachometer voltage. The relay is adjusted to energize at a predetermined tachometer voltage and remains energized as the voltage increases. Relay contacts are wired to the modification board for customer use. These contacts are rated at 125 VAC at 3 amps. The tachometer voltage (speed) trip point can be adjusted to operate from zero to above rated drive speed.

INSTALLATION

WARNING
REMOVE ALL INPUT POWER TO DRIVE BEFORE INSTALLING MODIFICATION KIT

This modification PCB is to be installed to area D of the Regulator PCB as shown in the illustration on this page. Installation instructions are contained in the Controller instruction manual.

After installing the modification PCB, apply the schematic overlay to area D of the simplified schematic diagram as described in the Controller instruction manual.

INTERCONNECTION

This modification requires no special interconnections.

Perform equipment interconnection according to the Controller instruction manual

ADJUSTMENTS

After performing the adjustments in the Controller instruction manual, adjust the modification PCB as follows.

1. Turn the TRIP SPEED potentiometer fully clockwise and start the drive.
2. Rotate the SPEED CONTROL potentiometer until drive is running at the desired trip speed.
3. Slowly rotate the TRIP SPEED potentiometer counterclockwise until the modification relay energizes. Trip point will be at zero speed with TRIP SPEED potentiometer in mid position and above rated speed with TRIP SPEED potentiometer fully clockwise.
4. If desired rates cannot be obtained, perform modification kit troubleshooting procedures.

TROUBLESHOOTING

Troubleshooting consists of checking the operation of the electronically operated relay when the STOP pushbutton is pressed.

1. Rotate the TRIP SPEED potentiometer fully counterclockwise. The modification relay should be energized. If not, replace the Adjustable Speed Trip PCB.
2. Monitor the voltage between 6CONN(1) and 12CONN(6) of the Regulator PCB (common). Press the RUN pushbutton and vary the drive speed from minimum to maximum. The voltage should vary proportionately. If not, refer to the troubleshooting charts in the Controller instruction manual.

MODIFICATION RECORDS

After completing mod kit installation:

- A. Modify Controller identification number using Method 1 in the Controller instruction manual. Place the number "2" in the block corresponding to modification area D.
- B. Insert this instruction sheet inside the back cover of the Controller instruction manual.

INSTRUCTION SHEET
FOR MODIFICATION D2
Sheet 1 of 1
02Y00025-0011

TROUBLESHOOTING

If other mod boards have been installed, be sure to troubleshoot them thoroughly before discarding this board as faulty

Troubleshooting consists of checking the relay operation while the Controller is energized

- 1 Apply AC input power to the Controller but do not press RUN pushbutton Set SPEED CONTROL potentiometer fully counterclockwise
2. Note the setting of the TRIP SPEED potentiometer Rotate the TRIP SPEED potentiometer counterclockwise The trip relay should be deenergized; if not, replace the Differential Trip PCB
- 3 Rotate the TRIP SPEED potentiometer fully clockwise The trip relay should be deenergized; if not, replace the Differential Trip PCB
- 4 Press RUN pushbutton and turn the SPEED CONTROL potentiometer fully clockwise. If the relay on the Differential Trip PCB energizes, check the differential trip adjustment

MODIFICATION RECORDS

After completing mod kit installation:

- A. Modify Controller identification number using Method 1 in the Controller instruction manual Place the number "3" in the block corresponding to modification area D.
- B Insert this instruction sheet inside the back cover of the Controller instruction manual.

For use with Type MC and HC
Eddy Current Drives.

MODIFICATION E1 ADJUSTABLE BREAKAWAY

KIT 46S02051-0080

PCB 46S02046-0010 SCHEMATIC 45S02046-0010

Before installing this kit, a **TECHNICALLY QUALIFIED INDIVIDUAL**, who is familiar with this type of equipment and hazards involved, should **READ** this **ENTIRE INSTRUCTION SHEET**.

After installing the modification PCB, apply the schematic overlay to area E of the simplified schematic diagram as described in the Controller instruction manual.

IMPORTANT

This kit may have been installed by the factory. However, certain steps can only be completed at the installation site. Therefore, review and then perform those steps which complete the installation process.

DESCRIPTION

This modification kit is one of a series of kits available for the Louis Allis eddy current drives. It consists of components necessary for modifying the basic Controller to provide a starting torque boost each time the drive is started. It also includes front panel nameplates and modification diagrams for the basic MOD 7 Controller instruction manual.

INSTALLATION

WARNING

REMOVE ALL INPUT POWER TO DRIVE BEFORE INSTALLING MODIFICATION KIT.

This modification PCB is to be installed to area E of the Regulator PCB as shown in Figure 1. Installation instructions are contained in the Controller instruction manual.

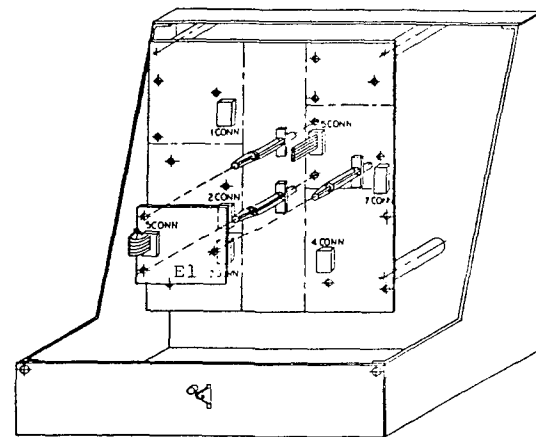

Figure 1.

INTERCONNECTION

This modification requires no special interconnections.

Perform equipment interconnection according to the Controller instruction manual.

ADJUSTMENTS

After performing the adjustments in the Controller instruction manual, adjust the modification PCB as follows.

1. Turn the **BREAKAWAY** potentiometer fully counterclockwise and adjust the

CHANGE RECORD

1	T.D. REFORMER			
	12/21/81			

DWG. NO. 02Y00025-0009
SHEET 1 OF 2
EFF. 2/5/81 (E)

speed control settings so that the drive would normally be rotating. Start the drive and note the drive breakaway, or time required for the drive to start moving.

2. Stop the drive. If a faster breakaway is required, turn the BREAKAWAY potentiometer slightly clockwise and restart the drive, again noting the breakaway action.

3. Repeat step 2 until required breakaway is obtained. If desired action cannot be obtained, perform modification kit troubleshooting procedures.

TROUBLESHOOTING

Troubleshooting this modification consists of checking circuit components using a volt-ohm meter. If any component is defective, replace the Adjustable Breakaway PCB.

MODIFICATION RECORDS

After completing mod kit installation:

A. Modify Controller identification number using Method 1 in the Controller instruction manual. Place the number "1" in the block corresponding to modification area E.

B. Insert this instruction sheet inside the back cover of the Controller instruction manual.

DWG. NO. 02Y00025-0009
SHEET 2 OF 2
EFF. 2/5/81 (E)

MODIFICATION E2
FOR EDDY CURRENT DRIVE
(KIT P/N 46SO2051-0070)
TORQUE LIMIT WITH BOOST

Effective
2-4-81
Supercedes
12-80

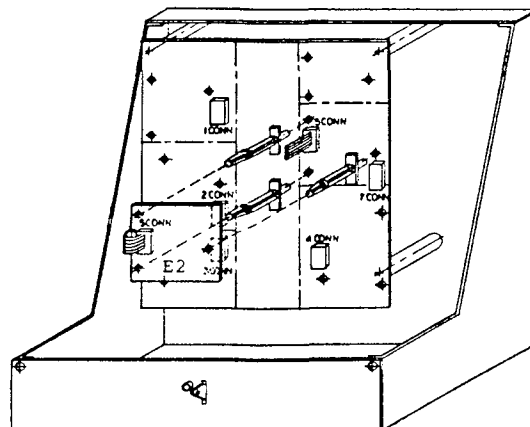

MOD PCB
46SO2045-0010
SCHEMATIC
45SO2045-0010

DESCRIPTION:

This modification kit is one of a series of kits available for the Louis Allis eddy current drives. It consists of components necessary for modifying the basic Controller for limiting the amount of torque the drive can deliver to the load. It also includes front panel nameplates and modification diagrams for the basic MOD 7 Controller instruction manual.

The torque limit portion of this modification controls the maximum drive torque by monitoring and limiting the clutch field current. When the clutch current tries to exceed a preset value, a signal is fed to the Regulator node to prevent any additional increase in clutch current. The preset value of maximum clutch current is adjustable by means of the MAX TORQUE potentiometer. The maximum torque adjustment covers the range of 20 to 100% of Controller current rating.

The boost portion of this modification disables the torque limit feature when the tachometer speed exceeds the preset boost speed. The boost speed is adjustable by means of the BOOST potentiometer and can be adjusted from zero to beyond rated drive speed. When set at maximum, the torque limit function is always operational. This condition is undesirable under most circumstances because the clutch cannot deliver high torque to the load at high speed without an increase in clutch field current.

INSTALLATION

WARNING
REMOVE ALL INPUT POWER TO DRIVE BEFORE INSTALLING MODIFICATION KIT

This modification PCB is to be installed to area E of the Regulator PCB as shown in the illustration on this page. Installation instructions are contained in the Controller instruction manual.

After installing the modification PCB, apply the schematic overlay to area E of the simplified schematic diagram as described in the Controller instruction manual.

INTERCONNECTION

This modification requires no special interconnections.

Perform equipment interconnection according to the Controller instruction manual.

ADJUSTMENTS

After performing the adjustments in the Controller instruction manual, adjust the modification PCB as follows.

1. Turn MAX TORQUE potentiometer fully counter-clockwise and BOOST SPEED potentiometer fully clockwise.
2. Start the drive and turn SPEED CONTROL potentiometer clockwise so that drive is operating at a reasonable speed but not faster than approximately 75% of rated speed. With the drive operating, slowly turn the MAX TORQUE potentiometer clockwise until the drive output torque increases to the desired limited value.
3. Press the STOP pushbutton. Then restart the drive, noting the acceleration or other operation with limited torque. Readjust MAX TORQUE potentiometer if required to obtain desired maximum torque and repeat this step until desired torque is obtained when drive is started or running at low speed.

INSTRUCTION SHEET
FOR MODIFICATION E2
Sheet 1 of 2
02Y00025-0006

- 4 Adjust the SPEED CONTROL potentiometer for the speed at which the torque limit feature is to be disabled.
5. Connect a voltmeter between E2TP on this modification and 12CON(6) of the Regulator PCB (common).
6. With BOOST SPEED potentiometer fully clockwise, the voltmeter should indicate approximately -15 VDC. Slowly turn the BOOST SPEED potentiometer counterclockwise until voltmeter indication goes to zero or positive DC voltage. The torque limit action will now be disabled whenever the tachometer is at or beyond this speed.

TROUBLESHOOTING

If other mod boards have been installed, be sure to troubleshoot them thoroughly before discarding this board as faulty.

Troubleshooting consists of checking the input and output voltages of the circuit while the drive is operating.

1. Start the drive and rotate SPEED CONTROL fully clockwise
- 2 If the drive does not run at all, remove power and disconnect the flat cable connector at the modification PCB. Restart the drive and determine if drive runs normally without the Torque Limit with Boost modification. If drive runs normally, replace Torque Limit with Boost PCB.
- 3 If the drive runs while the Torque Limit with Boost modification is installed but does not run properly, perform the adjustment procedure. If adjustment cannot be performed satisfactorily, replace the Torque Limit with Boost PCB.

MODIFICATION RECORDS

After completing mod kit installation:

1. Modify Controller identification number using Method 1 in the Controller instruction manual. Place the number "2" in the block corresponding to modification area E.
2. Insert this instruction sheet inside the back cover of the Controller instruction manual.

MODIFICATION E3 TORQUE LIMIT (250% MOTOR CURRENT)

KIT 46S02051-0400

PCB 46S02151-0020 SCHEMATIC 45S02151-0020

Before installing this kit, a **TECHNICALLY QUALIFIED INDIVIDUAL**, who is familiar with this type of equipment and hazards involved, should **READ** this **ENTIRE INSTRUCTION SHEET**.

IMPORTANT

This kit may have been installed by the factory. However, certain steps can only be completed at the installation site. Therefore, review and then perform those steps which complete the installation process.

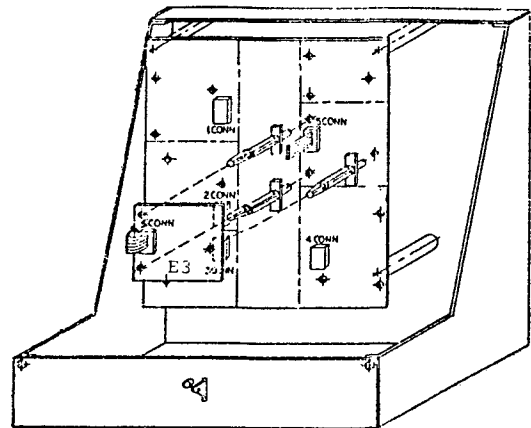

Figure 1

DESCRIPTION

This modification kit is one of a series of kits available for the Louis Allis eddy current drives. It consists of components necessary for modifying the basic Controller to limit AC motor current to a set value. This kit also includes a front panel nameplate and a modification diagram for the basic MOD 7 Controller instruction manual.

The E3 modification monitors the current drawn by the AC motor, and adjusts the clutch coil excitation to limit the motor current. Current limiting action is present during both acceleration and running conditions. The range of adjustment is from 50% to 250% of rated motor current.

The motor current is to be sampled by a standard window-type current transformer, such as the Westinghouse ECI model. The

output of the secondary winding must be two ampere when the motor is drawing its full rated current. An AC ammeter rated for five amperes at full scale may be placed in series with the CT secondary in order to read 0 to 250% of rated motor current. Procedures to achieve the correct current are presented in the Transformer Instruction sheets.

The 5-ampere secondary current transformer samples the motor current, and the current transformer burden resistor voltage is then rectified in an absolute value circuit. The output is fed to an error amplifier, which provides signals to clamp clutch excitation and to inhibit brake excitation (on clutch-brake Controllers) when the AC motor current exceeds that value set by 1RH on the modification PCB.

CHANGE RECORD				DWG. NO. 02Y00025-0036 SHEET 1 OF 6 EFF. 2/9/81 (H)
1	STD-1271	7/14/81		
2	STD-3128	7/5/88		
		RR		

INSTALLATION

WARNING

REMOVE ALL INPUT POWER TO DRIVE
BEFORE INSTALLING MODIFICATION KIT.

This modification PCB is to be installed in area E of the Regulator PCB as shown in Figure 1. Installation instructions are contained in the Controller instruction manual.

After installing the modification PCB, apply the schematic overlay to area E of the simplified schematic diagram as described in the Controller manual.

INTERCONNECTION

This modification requires that a current transformer be installed on one of the motor leads. Wire the transformer according to the following instructions and as shown on schematic 45S02151-0020. Then perform all other equipment interconnection according to the Controller instruction manual.

Current Transformer Instructions

The primary/secondary turns ratio determines the current output. A ratio

of 100:5, for example, means that when 100 amperes flows in a cable passed once through the window, the secondary circuit will furnish 5 amperes to the E3 Modification PCB. The rated full load current of the motor being controlled will probably be different from the example, but the transformer must still be made to produce 5 amperes at 250% motor current or 2 amperes at rated motor current.

This can be done by externally altering the turns ratio in the following manner. Pass the motor cable (which is in fact the primary of the transformer) through the window more than once, and/or loop a single lead from the secondary terminals one or more times through the window. Depending on which lead is used, turns can effectively be either added to (+) or subtracted from (-) the original number of secondary turns.

In Table 1, locate the rated current of the motor being controlled. Read across to find the number of primary passes and secondary turns needed.

Figure 2 illustrates how to pass the motor cable through, as well as how to wind the secondary. Table 1 lists secondary turns as either plus or minus,

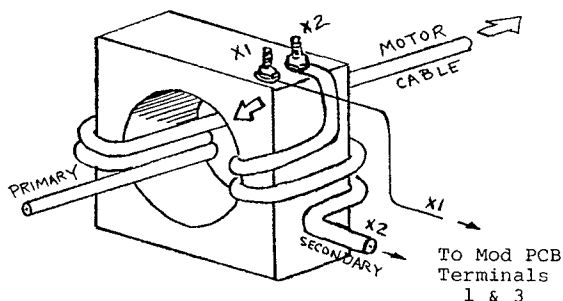

3-pass Primary
with 2 turns ADDED
to Secondary (+)

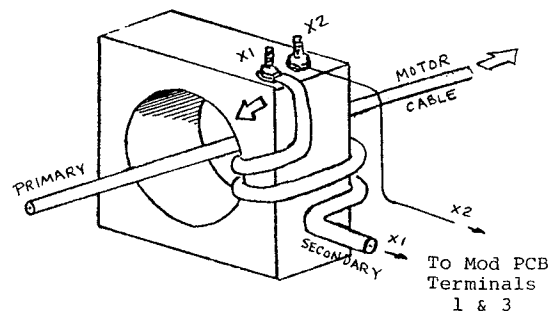

1-pass Primary
with 2 turns SUBTRACTED
from Secondary (-)

Figure 2.

DWG. NO. 02Y00025-0036
SHEET 2 OF 6
EFF. 2/9/81 (H)

meaning to add or subtract turns. To subtract, start from the terminal nearest the arrow on the side of the case. To add turns, start from the other terminal. In either case, pass only one lead through the window, in the direction of the arrow. The other lead goes straight to the Mod PCB terminal board.

ADJUSTMENT

1. Turn IRH to minimum (full CCW).
2. Start the drive.
3. Accelerate drive or load heavily.
4. Note motor current through use of an external meter (not supplied).
5. Increase setting of IRH until maximum AC motor current is limited to the desired value.
6. Repeat the acceleration or heavy load to check.

TROUBLESHOOTING

If other mod boards have been installed, be sure to troubleshoot them thoroughly before discarding this board as faulty.

If the AC motor draws too much current, check for the presence of approximately 0.2 volts between terminals E1 and E3, to verify that the current transformer and its burden resistor are good.

When current limiting takes place, E1TP will go negative with respect to chassis common. Check for the presence of this voltage.

MODIFICATION RECORDS

After completing mod kit installation:

1. Modify Controller identification number using Method 1 in the Controller instruction manual. Place the number (3) in the block corresponding to modification area E.
2. Insert this instruction sheet inside the back cover of the Controller instruction manual.

DWG. NO. 02Y00025-0036
SHEET 3 OF 6
EFF. 2/9/81 (H)

Table 1. Current Transformer Wiring

LOUIS ALLIS PART NUMBER 05P00068-	RATED FLA	C.T. RATIO	PRIMARY PASSES	SECONDARY TURNS (NOTE 1)
-0056	1.4	100:5	15	-9
	1.7		23	0
	2.2		18	0
	2.65		15	0
	2.8		10	-6
	2.9		10	-5
	3.1		10	-5
	3.2		12	0
	3.75		15	+8
	4.3		10	+1
	4.4		10	+2
	5.3		10	+6
	5.4		7	-1
	6		7	+1
	6.4		6	-1
	7		6	+1
	7.5		4	-5
	8.5		4	-3
	8.6		3	-7
	9.5		4	-1
	11		4	+2

DWG. NO. 02Y00025-0036
 SHEET 4 OF 6
 EFF. 2/9/81 (H)

Table 1. Current Transformer Wiring (Continued)

LOUIS ALLIS PART NUMBER 05P00068-	RATED FLA	C.T. RATIO	PRIMARY PASSES	SECONDARY TURNS (NOTE 1)
-0056 (Cont'd)	12	100:5	3	-2
	13		4	+6
	14		3	+1
	16		2	-4
	17		2	-3
	18		2	-2
	19		2	-1
	22		2	+2
	24		2	+4
	25		2	+5
	27		1	-6
	36		1	-2
	37		1	-1
	38		1	-1
	50		1	+5
-0037	62	150:5	1	+1
	68		1	+4
-0058	74	200:5	1	-3
	79		1	0
	85		1	+2

DWG. NO. 02Y00025-0036
 SHEET 5 OF 6
 EFF. 2/9/81 (H)

Table 1. Current Transformer Wiring (Continued)

LOUIS ALLIS PART NUMBER 05P00068-	RATED FLA	C.T. RATIO	PRIMARY PASSES	SECONDARY TURNS (NOTE 1)
-0058 (Cont'd)	87	200:5	1	+3
	92		1	+6
-0059	100	300:5	1	-10
	110		1	-5
	121		1	0
	123		1	+1
	124		1	+2
-0038	150	400:5	1	-5
	152		1	-4
	156		1	-2
-0040	190	600:5	1	-25
-0041	270	800:5	1	-25

Note 1. A zero (0) indicates that neither secondary lead passes through the current transformer window.

DWG. NO. 02Y00025-0036
 SHEET 6 OF 6
 EFF. 2/9/81 (H)