

GPD 333

Technical Manual



QUICK REFERENCE - - GPD 333 CONSTANTS

CONSTANT	FACTORY SETTING	USER SETTING
<i>no-00</i>	01	
<i>no-01</i>	0000	
<i>no-02</i>	60.0	
<i>no-03</i>	230.0	
<i>no-04</i>	60.0	
<i>no-05</i>	1.5	
<i>no-06</i>	12.0	
<i>no-07</i>	1.5	
<i>no-08</i>	12.0	
<i>no-09</i>	10.0	
<i>no-10</i>	10.0	
<i>no-11</i>	10.0	
<i>no-12</i>	10.0	
<i>no-13</i>	0.0	
<i>no-14</i>	0.0	
<i>no-15</i>	0.0	
<i>no-16</i>	0.0	
<i>no-17</i>	6.0	
<i>no-18</i>	0000	
<i>no-19</i>	See para. 3.8 in manual	
<i>no-20</i>	0000	
<i>no-21</i>	0000	
<i>no-22</i>	1.00	
<i>no-23</i>	0.00	
<i>no-24</i>	100	
<i>no-25</i>	0	
<i>no-26</i>	50	

CONSTANT	FACTORY SETTING	USER SETTING
<i>no-27</i>	0.0	
<i>no-28</i>	0.0	
<i>no-29</i>	1.0	
<i>no-30</i>	170	
<i>no-31</i>	160	
<i>no-32</i>	13	
<i>no-33</i>	01	
<i>no-34</i>	03	
<i>no-35</i>	00	
<i>no-36</i>	05	
<i>no-37</i>	00	
<i>no-38</i>	01	
<i>no-39</i>	0.0	
<i>no-40</i>	0000	
<i>no-41</i>	160	
<i>no-42</i>	0.1	
<i>no-43</i>	4 (= 10 kHz)	

Constant *no-44* currently NOT USED.

<i>no-45</i>	1.00	
<i>no-46</i>	0000	
<i>no-47</i>	0	

Constants *no-48* and *no-49* are for display-only functions; no user setting possible.

<i>no-50</i>	0.0	
<i>no-51</i>	1.0	

Constants *no-52* thru *no-59* currently NOT USED.



WARNING

Do not touch circuit components until main input power has been turned off and "CHARGE" lamp is extinguished. The capacitors are still charged for up to 5 minutes and can be quite dangerous.

Do not connect or disconnect wires and connectors while power is applied to the circuit.

CAUTION

The GPD 333 leaves the factory with constants initialized for external 2-Wire control and constant *no-00* set to 01 . Before using either initialization function of this constant, know your control wiring configuration :

08 = Factory 2-Wire control initialization (maintained Run contact)

09 = Factory 3-Wire control initialization (momentary Start/Stop input)

Entering either initialization code returns all constants to factory settings, and automatically returns constant *no-00* setting to 01 . If the GPD 333 is connected for 3-Wire control and this constant is set to 08 (2-Wire control initialization), the motor may run in reverse direction **WITHOUT A RUN COMMAND APPLIED**.

Equipment damage or personal injury may result.

Constant *no-03* must be set for the proper motor voltage. Drive leaves factory with this constant set for 230.0 or 460.0 volts.

CAUTION

Always ground the GPD 333 using ground terminal G (E). See paragraph 1.4.2 "Grounding".

Never connect main circuit output terminals T1 (U), T2 (V) & T3 (W) to AC main circuit power supply.

CAUTION

Do not perform a withstanding voltage test on any part of the GPD 333. Equipment uses semi-conductors and is vulnerable to high voltage.

The Control PC board employs CMOS ICs which are easily damaged by static electricity. Use proper electrostatic discharge (ESD) procedures when handling the Control PC board.

IMPORTANT

All constants have been factory set. Do not change their settings unnecessarily. Changing constant settings requires use of the optional Digital Operator, Model DS039.

CONTENTS

<u>SUBJECT</u>	<u>Page</u>
WARNINGS & CAUTIONS	i
GPD 333 NEMA1 DIMENSIONS (Figure 1-1)	iv
GPD 333 NEMA 4/12 DIMENSIONS and Fusing	56
SECTION 1 INSTALLATION	1
1.1 General	1
1.2 Receiving	1
1.3 Physical Installation	1
1.3.1 Installation or Removal of Digital Operator	1.1
1.4 Electrical Installation	4
1.4.1 Conformance to European EMC Directive	4.1
1.5 Start-up	14
1.6 Start-up Without Digital Operator (2-Wire Control) ..	15
1.7 Start-up Using Digital Operator, Model DS039	16
SECTION 2 DIGITAL OPERATOR, MODEL DS039	18
2.1 General	18
2.2 Drive Mode Operation	20
2.3 Program Mode Operation	20
SECTION 3 PROGRAMMABLE FEATURES	22
3.1 General	22
GPD 333 Constants	22
SECTION 4 FAULT/WARNING FUNCTIONS	49
4.1 General	49
4.2 Troubleshooting	49
4.2 Fault Functions	50
4.3 Warning Functions	52
GPD 333 SPECIFICATIONS	53
APPENDIX 1 DYNAMIC BRAKING OPTION	57
APPENDIX 2 GPD 333 SPARE PARTS	63

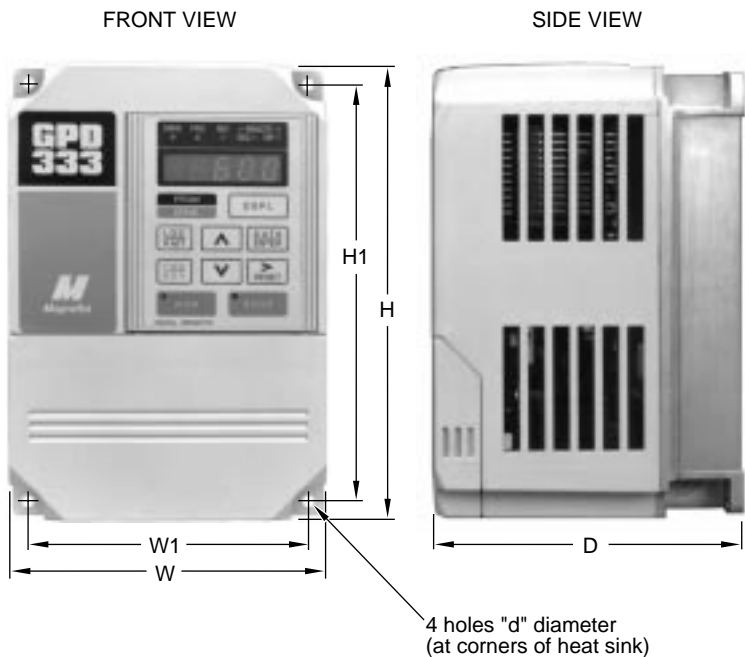

RATED INPUT	MODEL NO.	DIMENSIONS in inches (mm)					
		H	W	D	H1	W1	d
230V	DS020, 21	5.91 (150)	4.13 (105)	3.94 (100)	5.43 (138)	3.66 (93)	0.20 (5)
	DS022, 29	5.91 (150)	5.51 (140)	5.47 (139)	5.43 (138)	5.04 (128)	0.20 (5)
	DS023 - 25	7.87 (200)	5.51 (140)	6.69 (170)	7.32 (186)	4.96 (126)	0.22 (6)
460V	DS040, 41	7.87 (200)	5.51 (140)	4.72 (120)	7.32 (186)	4.96 (126)	0.22 (6)
	DS042, 43	7.87 (200)	5.51 (140)	6.69 (170)	7.32 (186)	4.96 (126)	0.22 (6)
	DS044, 45	7.87 (200)	7.48 (190)	7.48 (190)	7.28 (185)	6.89 (175)	.024 (7)

Figure 1-1. GPD 333 NEMA 1 Dimensions

NOTE: For GPD 333 NEMA 4/12 dimensions, see page 56.

Section 1 INSTALLATION

1.1 GENERAL. The GPD 333 is a high performance pulse width modulated design which generates a sine-coded, adjustable voltage/frequency three phase output for complete speed control of any conventional squirrel cage induction motor. The GPD 333 can maintain a 150% current overload capability for 60 seconds. The GPD 333 will not induce any voltage line notching distortion back to the utility line and maintains a displacement power factor of not less than 0.98 throughout its speed range.

When properly installed, operated and maintained, the GPD 333 will provide a lifetime of service. It is mandatory that the person who operates or maintains this equipment thoroughly read and understand this manual before proceeding.

1.2 RECEIVING. The GPD 333 is thoroughly tested at the factory. After unpacking, verify the part numbers with the purchase order (invoice). Any damages or shortages evident when the equipment is received must be reported immediately to the commercial carrier who transported the equipment. Assistance is available from your sales representative.

1.3 PHYSICAL INSTALLATION. Location of the GPD 333 (Figure 1-1) is important to achieve proper performance and normal operating life. The unit should be installed in an area where it will be protected from:

- Direct sunlight, rain or moisture.
- Corrosive gases or liquids.
- Vibration, airborne dust or metallic particles.

For effective cooling as well as proper maintenance, the GPD 333 must be installed vertically. There MUST be a MINIMUM 4.0 inch clearance above and below, and a MINIMUM 1.18 inch clearance on each side.

For open type chassis, remove top cover and terminal cover. When mounting units in an enclosure, make sure air entering drive is below 113° F (45° C).

1.3.1 Installation or Removal of Digital Operator.

The GPD 333 is shipped with the status panel (shown at right) in place. If programming of constants is to be performed, or if local control via keypad entry is desired, the optional Digital Operator, Model DS039, must be installed.

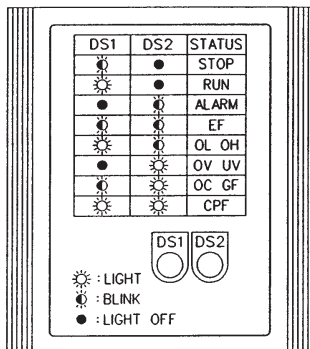

Status Plate

1. Ensure that input power is not applied to the GPD 333, and the "CHARGE" lamp is off.
2. Remove the GPD 333 access cover (see Figure 1-2).
3. Press down on the terminal marker lever (see View B in Figure 1-1.1), and lift upward on the bottom edge of the status plate to remove it from the mounting recess.
4. Locate the Digital Operator in the mounting recess, as shown in View A of Figure 1-1.1, and press until it snaps into place.
5. Reinstall the access cover.

If, after constant programming, the drive is not to be operated or monitored via the Digital Operator, it may be removed without affecting operation. Perform the same procedure as above to remove the Digital Operator and reinstall the status plate.

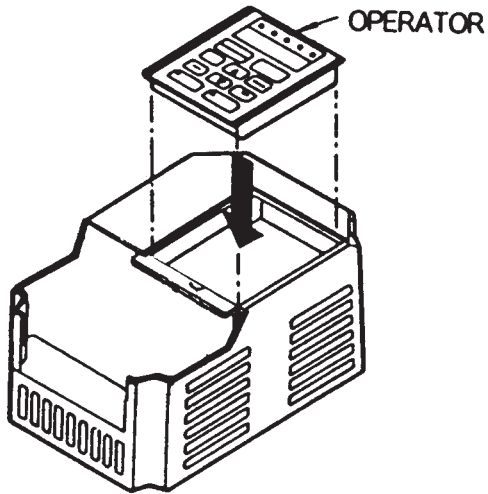

View A - Installing

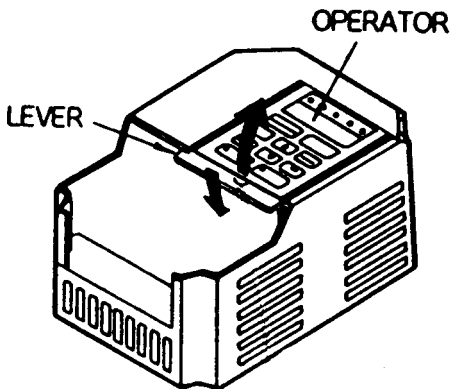

View B - Removing

Figure 1-1.1. Installing/Removing Digital Operator



NOTE: No tools required for cover removal.

Figure 1-1. Access Cover Removal



- ① Control circuit terminals: FLT-A, -B & -C.
- ② Control circuit terminals: L1 - L3, B1/+, B2, T1 - T3.
- ③ "CHARGE" lamp.
- ④ "G" terminal screws, for drive grounding and shield sheath.
- ⑤ Wire entry grommets.
- ⑥ Control circuit terminals: 1 - 7.
- ⑦ Control circuit terminals: 8 - 14.
- ⑧ Optional Digital Operator, in place.

Figure 1-3. Component Identification

1.4 ELECTRICAL INSTALLATION. The GPD 333 leaves the factory with all constants set for 2-Wire external reference control. Figure 1-5 must be used for all external connections.

To use the GPD 333 in a 3-Wire application, drive constants *no-00* and *no-01* must be reprogrammed, using the optional Digital Operator, Model DS039. Figure 1-6 must then be used for all external connections.

CAUTION

Use only UL listed or CSA certified closed loop (ring lug) connectors sized for the selected wire gauge. The connectors are to be installed using the correct crimp tool recommended by the connector manufacturer.

WIRE SIZE		TERMINAL SCREW	CLOSED-LOOP CONNECTOR
AWG	mm ²		
20	0.5	M3	1.25 - 3.5
18	0.75		
16	1.25		
14	2	M4	2 - 4
		M5	2 - 5
12	3.5	M4	3.5 - 4
		M5	3.5 - 5
10	5.5	M4	4 - 5.5
		M5	5 - 5.5

1.4.1 Conformance to European EMC Directive. As of January 1, 1996, all CE marked products on the European Market had to meet the protection requirement of Electromagnetic Compatibility Directive (EMC) 89/366/EEC. In order for any Electrical system to meet the emission and immunity levels set forth by the European standards, the components that make up the system should individually meet the levels. To meet the required levels of conformance, MagneTek has outlined the methods for the line filter application, cable shielding, and GPD 333 drive installation. The outline of the methods follows:

The line filter and the GPD 333 drive must be mounted on the same metal plate. The filter should be mounted as close to the drive as practical. The cable must be kept as short as possible and the metal plate should be securely grounded. The ground of the line filter and the drive must be bonded to the metal plate with as much area as possible.

For main circuit input cables, a screened cable is recommended at least within the panel. The screen of the cable should be connected to a solid ground. For the motor cables, a screened cable (max. 20 m) must be used and the screen of the motor cable should be connected to ground at both ends by a short connection using as large an area as practical.

For more detailed information, refer to MagneTek document TD 4077, "Installation Guidelines For EMC Directive using MagneTek AC Drive Products."

The following charts and Figure 1-3.1 show the line filter list for the EMC standards and the installation/wiring of the GPD 333 drive and line filter.

Line Filters For GPD 333

Drive Model Number	Line Filter							
	MagneTek Part Number	Rated Current (A)	Mass (kg)	Dimensions in mm H x W x D ⁽¹⁾				
DS020	5P325-0041	8	1.1	250 x 145 x 38				
DS021								
DS022					5P325-0042	15	1.2	250 x 190 x 39
DS029								
DS023								
DS024								
DS025								
DS040	5P325-0041	8	1.1	250 x 145 x 38				
DS041								
DS042								
DS043								
DS044	5P325-0042	15	1.2	250 x 190 x 39				
DS045								

(1) D is the distance the filter will extend outward from the surface of the metal plate.

Conversion Note: 1mm = .0394 in.

Output Chokes For GPD 333

MagneTek Part Number	Center Hole (mm)	Width (mm)	Height (mm)	Mounting Hole Spacing (mm)
5P10-0466	50	150	110	125

Pass each wire through the choke 3 times. Additional noise reduction gains can be made by passing wire through the choke additional times.

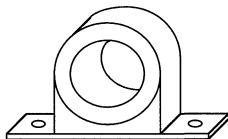

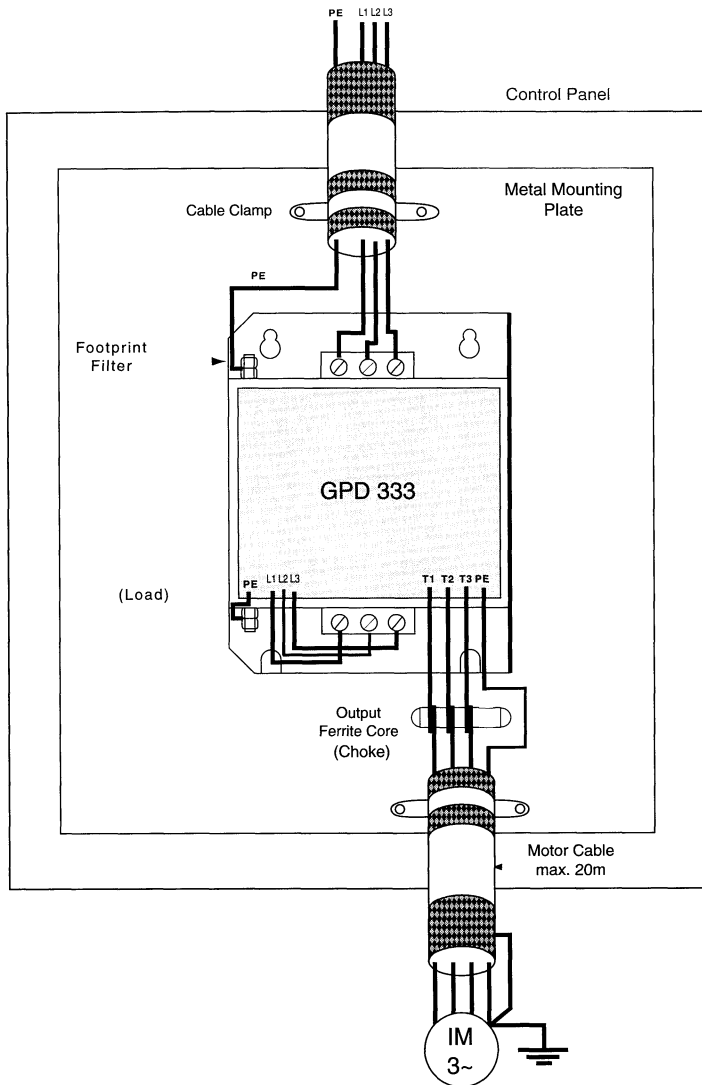
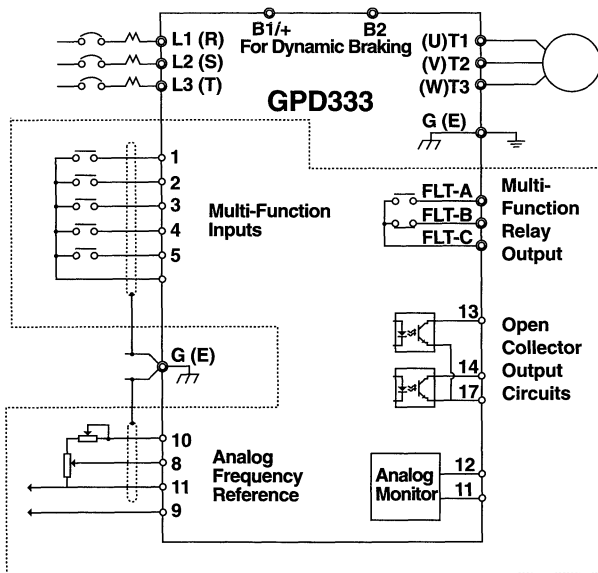

Figure 1-3.1. Installation of Line Filter and GPD 333

WARNING

- The control circuits (inside of the dashed line) are isolated from the power circuits by only basic⁽¹⁾ insulation.



- Make sure to ground the ground terminal **G(E)** according to the local electrical code.
- To conform to CE requirements, make sure to ground the supply neutral. (460V models only)
- If the control circuits are to be connected to circuits classified as Safety Extra Low Voltage (SELV), an additional isolating barrier must be included in order to maintain the SELV classification.
- In order to conform to EMC standards, the exclusive-use methods are required for line filter application, cable shielding and drive installation. For a more detailed explanation, please consult MagneTek.

⁽¹⁾ Definition of basic insulation: Insulation applied to live parts to provide basic protection against electric shock.

Figure 1-3.2. Control Circuit Isolation

1.4.2 Grounding.

- The GPD 333 must be solidly grounded using main circuit ground terminal G (E) (see Figure 1-3). Ground resistance should be 100 ohms or less. Select lead size suitable for size of terminal screw. Make lead length as short as possible.
- NEVER ground the GPD 333 in common with welding machines, motors, or other large-current electrical equipment.
- Where several GPD 333s are used, ground each directly or daisy-chain to the ground pole(s). DO NOT FORM A LOOP WITH THE GROUND LEADS. See Figure 1-4.

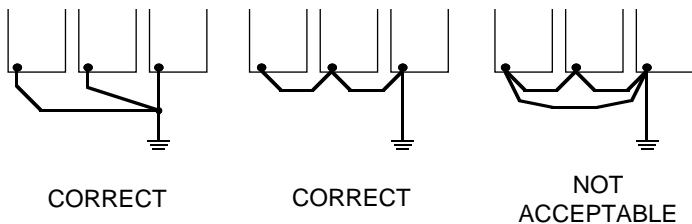

Figure 1-4. Grounding of Three GPD 333s

1.4.3 Main Circuit Input/Output. Observe the following while completing interconnections:

- Use only factory supplied installation instructions to install optional dynamic braking resistors. Failure to do so may cause equipment damage or personal injury.
- Use 600V vinyl-sheathed lead (75° C copper wires) or equivalent. Wire size should be determined by considering voltage drop of leads. Size of wire must be suitable for Class 1 circuits.
- Never connect AC main power to output terminals T1 (U), T2 (V), and T3 (W).
- Never allow wire leads to contact the GPD 333 enclosure. Short-circuit may result.
- Never connect power factor correction capacitors or noise filter to GPD 333 output.

Wire Sizing For Main Circuit

VOLTAGE / HORSEPOWER	TERMINAL SYMBOL	SCREW SIZE	WIRE SIZE	
			AWG	mm 2
ALL	FLT-A, FLT-B, FLT-C	M3.5	20 - 14	0.5 - 2
230V / 1/3-1	L1 (R), L2 (S), L3 (T), B1/+, B2, T1 (U), T2 (V), T3 (W)	M4	14 - 10	2 - 5.5
230V / 2-5	L1 (R), L2 (S), L3 (T), B1/+, B2, T1 (U), T2 (V), T3 (W)	M4	12 - 10	3.5 - 5.5
	G (E)	M4	14 - 10	2 - 5.5
460V / 1/2-5	L1 (R), L2 (S), L3 (T), B1/+, B2, T1 (U), T2 (V), T3 (W), G (E)	M4	14 - 10	2 - 5.5

- Torque M3.5 screws to .70 lb-ft.
- Torque M4 screws to 1.055 lb-ft.

Terminal Functions and Voltages of Main Circuit

TERMINAL	FUNCTION	VOLTAGE / SIGNAL
L1 (R) L2 (S) L3 (T)	Main circuit input power supply	Three Phase 230V Drive: 200 / 208 / 220 at 50Hz; 200 / 208 / 220 / 230V at 60Hz 460V Drive: 380 / 400 / 415 / 440 / 460V at 50/60Hz
T1 (U) T2 (V) T3 (W)	Main circuit output	Three Phase 230V Drive: 0 - 200 / 208 / 220 / 230V 460V Drive: 0 - 380 / 400 / 415 / 440 / 460 (matches input voltage)
FLT-A FLT-B FLT-C	Multi-Func. Relay output – NO contact Multi-Func. Relay output – NC contact Multi-Func. Relay output – common	250Vac, 1A or less (See Note 1) 30Vdc, 1A or less
B1+, B2	For connection of braking resistor or braking resistor unit (option)	
G (E)	Ground terminal (100 ohms or less)	----

NOTES:

- Any of 11 functions can be selected for multifunction relay output.

1.4.4 Control Circuit. All basic control circuit (signal) connections are shown in the appropriate diagram:

- Figure 1-5 shows connections for external 2-Wire control.
- Figure 1-6 shows connections for external 3-Wire control.
- Use class 1 twisted shielded or twisted-pair shielded wire, 20-14 AWG (0.5-2mm²), for control circuit leads. Wire size should be determined considering voltage drop in leads. Connect shield sheath **AT THE GPD 333 END ONLY**; the far end should be dressed neatly and left unconnected.

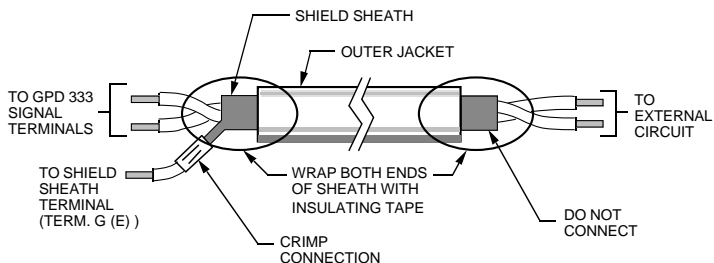

- Signal leads 1 thru 14 must be separated from main circuit leads L1 (R), L2 (S), L3 (T), T1 (U), T2 (V), T3 (W), FLT-A, B, & C leads, and any other power cables, to prevent erroneous operation caused by noise interference.
- Lead length should **NOT EXCEED 164 feet (50 meters)**.
- Recommended carrier frequency to reduce nuisance trips caused by leakage current:

Lead Length	Carrier Frequency (set by constant no-43)
under 100 feet	10.0 kHz
100 to 150 feet	5.0 kHz
over 150 feet	2.5 kHz

Control Circuit Terminal Functions

TYPE	TERM.	NAME	FUNCTION DESCRIPTION	SIGNAL LEVEL
Sequence Input Signal (See Note 2)	1	FWD Run / Stop Command	FWD run at closed, stop at open	(See Note 1) 24Vdc 8mA Photocoupler Isolated Warning: Dry contact or switch. Apply no external voltage.
	2	REV Run / Stop Command	REV run at closed, stop at open	
	3	Fault Reset	Reset at closed	
	4	External Fault Input	Fault at closed, normal at open	
	5	Multi-step Speed Ref 1	Multi-step speed ref 1 effective at closed	
	6	Sequence Control Input Common	--	
Analog Input Signal	10	Speed Ref Power Supply Terminal	Speed reference power supply	+12V (Up to 20mA current)
	8	Frequency Reference	0 - +10V / 100% frequency	0 - +10V (20k Ω)
	9		4 - 20mA / 100% frequency	4 - 20mA (250 Ω)
	11	Common Terminal For Control Circuit	0V	--
Sequence Output Signal (See Note 3)	13	Multifunction Open Collector Output 1	Factory Setting: "Low" level at run.	Open collector output +48V, 50mA or less
	14	Multifunction Open Collector Output 2	Factory Setting: "Low" level at set freq. = output freq.	
	7	Open Collector Output Common	---	
Analog Output Signal	12	Positive	0 - 10V /100% frequency; Possible to select current output	0 - 11V Max. 2mA or less.
	11	Common		

NOTES:

- When Forward Run/Stop and Reverse Run/Stop inputs are both closed for more than 500ms, the Digital Operator flashes "**EF**", or drive's LED display shows DS2 (RED) blinking, and the motor, if rotating, is decelerated to a stop according to constant **no-01**. This stop condition is not stored by the GPD 333. **IF ONE OF THE INPUTS IS OPENED, THE MOTOR WILL RUN.**
- Table is based on 2-Wire Reset. For 3-Wire Reset definitions of terminals 1 thru 5, see Figure 1-6.
- Any of 11 functions can be selected for each multifunction open collector output.

——— **NOTES FOR FIGURES 1-5** ———

- * - Indicates components not supplied.
 - ⊙ - Indicates main circuit terminal.
 - - Indicates control circuit terminal.
 - () - Indicates alternate terminal marking, i.e. (R) and L1.
1. Insulated twisted shielded wire is required.
 - 2-conductor #18 GA. (Beldon #8760 or equivalent)
 - 3-conductor #18 GA. (Beldon #8770 or equivalent)Connect shield only at GPD 333 end (terminal G (E)).
Stub and isolate other end.
 2. +12V voltage output current capacity of control terminal 10 is 20mA max.
 3. The GPD 333 Electronic Thermal Overload function (no-18 & no-19) meets the standards set by UL for motor thermal overload protection. If local code requires separate mechanical overload protection, an overload relay should be installed, interlocked with the GPD 333 as shown. It should be the manual reset type to prevent automatic restart following a motor fault and subsequent contact reclosure after cool down.
 4. Customer to connect terminal G (E) to earth ground.
 5. If Digital Operator is used, remote operators which duplicate functions of its command keys (see Figure 2-1) may not be required.
 6. For installation of Braking Resistor or Braking Resistor Unit, refer to Appendix 1, "Dynamic Braking Option".

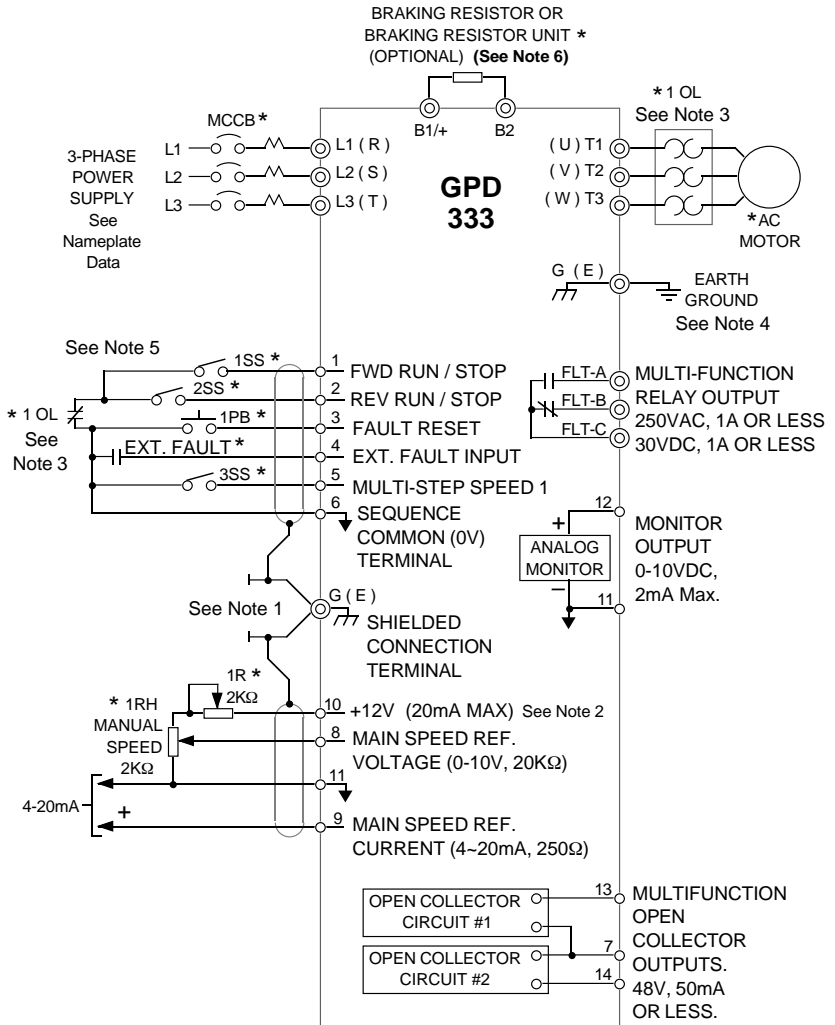

**Figure 1-5. Standard Connections (2-Wire Control)
(Constant no-00 set to 08)**

———— **NOTES FOR FIGURES 1-6** ————

- * - Indicates components not supplied.
 - ⊙ - Indicates main circuit terminal.
 - - Indicates control circuit terminal.
 - () - Indicates alternate terminal marking, i.e. (R) and L1.
1. Insulated twisted shielded wire is required.
 - 2-conductor #18 GA. (Beldon #8760 or equivalent)
 - 3-conductor #18 GA. (Beldon #8770 or equivalent)Connect shield only at GPD 333 end (terminal G (E)).
Stub and isolate other end.
 2. +12V voltage output current capacity of control terminal 10 is 20mA max.
 3. The GPD 333 Electronic Thermal Overload function (no-18 & no-19) meets the standards set by UL for motor thermal overload protection. If local code requires separate mechanical overload protection, an overload relay should be installed, interlocked with the GPD 333 as shown. It should be the manual reset type to prevent automatic restart following a motor fault and subsequent contact reclosure after cool down.
 4. Customer to connect terminal G (E) to earth ground.
 5. If Digital Operator is used, remote operators which duplicate functions of its command keys (see Figure 2-1) may not be required.
 6. For installation of Braking Resistor or Braking Resistor Unit, refer to Appendix 1, "Dynamic Braking Option".

CAUTION

Constant *no-32* must be set to " 00 ", AND constant *no-00* must be set to " 09 ". Resetting drive constant *no-00* to " 08 " may cause the motor to run in reverse direction **WITHOUT A RUN COMMAND, and possibly result in equipment damage or personal injury.**

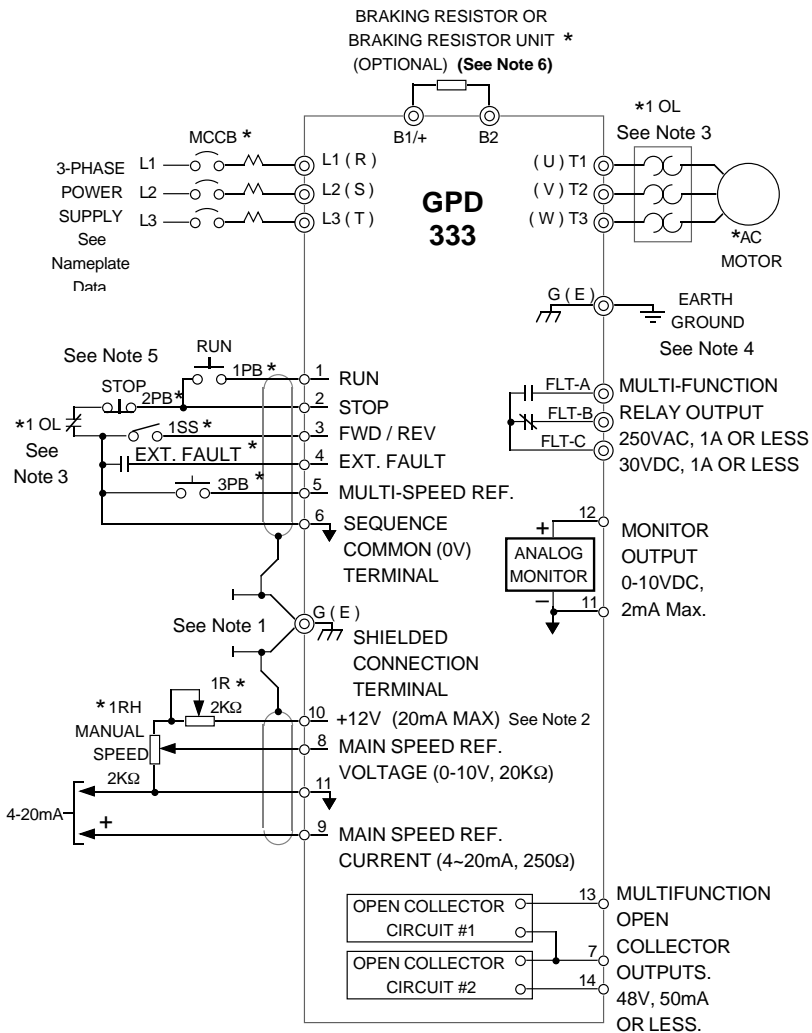

**Figure 1-6. Standard Connections (3-Wire Control)
(Constant no-00 set to 09)**

1.5 START-UP.

1.5.1 Pre-power Checks.

- Wires properly connected and no erroneous grounds exist.
- Motor not connected to load. After start-up procedure is completed, motor can be connected to load, and normal operation can begin.

1.5.2 Status Display LEDs. The standard GPD 333 has two LEDs that can be monitored on the status plate. They are DS1 (GREEN) and DS2 (RED). The GPD 333 has been factory set for external 2-Wire control and external speed reference (as shown in Figure 1-5). The LEDs are the only status indicators available without the optional Digital Operator. The chart below explains GPD 333 status while monitoring the LEDs.

Drive Status	Status Plate		Display Meaning
	DS1 (GREEN)	DS2 (RED)	
Normal	BLINKING	Off	Drive ready for operation, while in stopped condition.
	LIT	Off	Drive running.
Alarm	Off	BLINKING	Low input power, ext. base block input, etc., while in stopped condition.
Protective Operation	BLINKING	BLINKING	External fault signal is present at a drive input terminal (EF).
	LIT	BLINKING	Overload protection (drive overload (OL), fan overheat (OH), etc.).
	Off	BLINKING	Voltage protection (overvoltage (OV), undervoltage (UV), etc.).
	BLINKING	LIT	Overcurrent (OC), ground fault (GF).
Drive Fault	LIT	LIT	Digital hardware memory fault (CPF).
	Off	Off	Hardware fault, such as control power fault, CPU initialization, etc.

1.6 START-UP WITHOUT DIGITAL OPERATOR

(2-Wire control; see Figure 1-5) (constant *no-01* set to 0000 [factory setting])

ACTION	DESCRIPTION	Status Plate	
		DS1 (GREEN)	DS2 (RED)
Freq. Ref. set at zero; FWD RUN and REV RUN inputs open. Apply Power.	Ready for operation.	BLINKING	Off
Close FWD RUN or REV RUN input; increase Freq. Ref. until motor rotates.	Check that motor is rotating in the correct direction. See Note 1.	LIT	Off
Increase Freq. Ref. input to maximum.	GPD 333 output increases at programmed accel rate (constant <i>no-09</i> ; factory setting = 10.0 seconds accel time from 1.5Hz to 60Hz) to level commanded by frequency reference input. Motor speed increases accordingly.	LIT	Off
Open FWD RUN or REV RUN input.	Motor speed decreases under GPD 333 control, at programmed decel rate (constant <i>no-10</i> ; factory setting = 10.0 seconds decel time from 60Hz to 1.5Hz). Motor then remains stopped.	LIT (during decel)	Off
		BLINKING (when stopped)	Off

NOTES:

1. If motor is not rotating in proper direction, stop motor and turn off power to the GPD 333. Switch motor connections T1 (U) & T2 (V) at the GPD 333 to change direction.

1.7 START-UP USING DIGITAL OPERATOR,
MODEL DS039 (constant *no-01* set to 0011) (See Note 2)

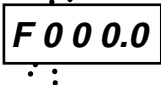
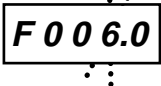
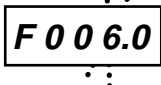
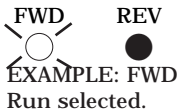
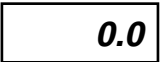
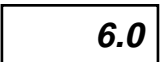
ACTION	DESCRIPTION	DISPLAY
Apply Power.	The Main Frequency Reference (constant <i>no-13</i>) set value appears.	
Use ►, ▲, and ▼ keys as necessary until display shows desired run frequency (6.0Hz).	Blinking position of display shifts to the right (►), value of blinking digit increases (▲) or decreases (▼), when keys are pressed.	
Press DATA ENTER key to write new value into memory.	Digit stops blinking for a short time; then digit resumes blinking.	
Press FWD REV key to select desired direction of motor rotation.	Observe FWD and REV indicator lamps on Digital Operator to see which direction motor should rotate when GPD 333 is started.	
Press DSPL key.	Present output frequency is displayed.	
Press RUN key.	Motor accels to 6.0Hz. Check for correct rotation of motor. See Note 1.	

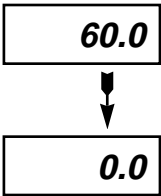
ACTION	DESCRIPTION	DISPLAY
Press DSPL key 3 times; change Freq. Ref. value to F 0 6 0.0 , and press DATA ENTER key. Press DSPL key again.	GPD 333 output increases to Frequency Reference level, at programmed accel rate. Motor speed increases accordingly.	
Press STOP key.	Motor speed decreases under GPD 333 control, at preset deceleration rate, to zero. Motor remains stopped.	

NOTES:

1. If motor is not rotating in proper direction, stop motor and turn off power to the GPD 333. Switch motor connections T1 (U) & T2 (V) at the GPD 333 to change direction.
2. If constant **no-01** is programmed with a "0" for either of the 0 0 X X digits, Digital Operator commands will be replaced by external inputs. See paragraph 3.3.

SECTION 2 DIGITAL OPERATOR (DS039)

2.1 GENERAL. This section describes the function of the Digital Operator, Model DS039. The GPD 333 can be operated by remote signal inputs without the need for the Digital Operator; however, for operation by means of keypad entry, or for changing of constant settings from the factory preset values (via Program mode), the Digital Operator must be connected to the GPD 333.

Mode Display LEDs:

Red lamp, lights in DRIVE mode and goes out in PRGM mode.

Red lamp, lights at FWD run.

Red lamp, lights at REV run.

Red lamps, light when control is by external terminal commands:

SEQ: When RUN/STOP signal is external.

REF: When frequency reference is external.

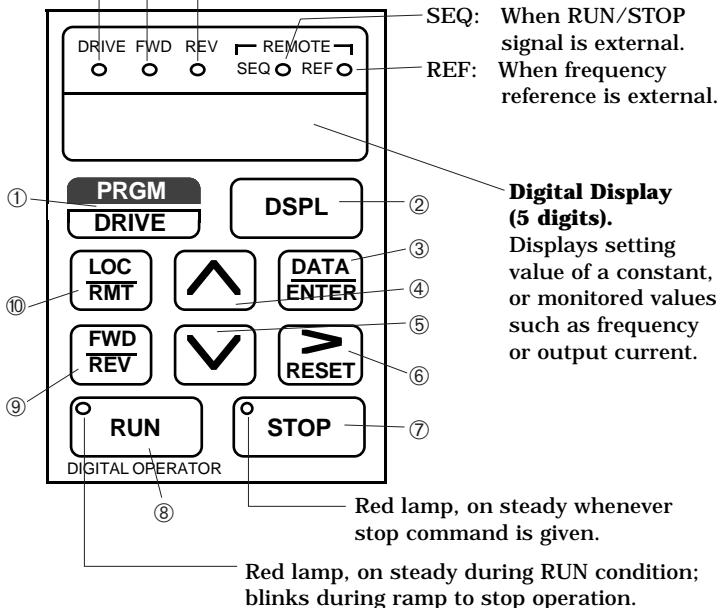

Figure 2-1. Digital Operator

Digital Operator Keypad Functions (ref. Figure 2-1):

Mode Selection Key (①). Press to change mode (DRIVE or PRGM). Active only when GPD 333 is in stopped condition.

Display Selection Key (②). In DRIVE mode, press to change the monitor display selection. In PRGM mode, it returns to display of presently selected constant.

Read / Write Key (③). In DRIVE mode, press to enter new frequency reference value (*FXXX.X*) into memory. In PRGM mode, pressing this key recalls and displays constant setting from memory. Press to enter displayed set value into memory.

Numeral Change Keys (④ and ⑤) change value of blinking digit in display: \wedge : Increment by 1 \vee : Decrement by 1

Digit Selection / RESET Key (⑥). Selects "changeable" (i.e. blinking) digit in display. Depress key to move one position to the right; "wraps around" from far right to far left position. This key resets operation of faults, in DRIVE mode only.

Command Keys:

(⑦): Initiates STOP command (in DRIVE mode).

(⑧): Initiates RUN command (in DRIVE mode).

(⑨): Selects FWD or REV run (in DRIVE mode).

(⑩): Press to change operation from remote to local.

Effective only in DRIVE mode, while in stopped condition.

NOTE

To disable the **LOC/RMT** (Local/Remote) key on the Digital Operator, program any one of the multi-function inputs, terminals 3, 4, or 5 (constants *no-32*, *no-33*, or *no-34*, respectively) for data **12** (Local/Remote), and leave that input terminal open. See page 37.

2.2 DRIVE MODE OPERATION.

A) This flow chart shows the display items in the Drive mode after the power supply is turned on. Press **DSPL** key to cycle.

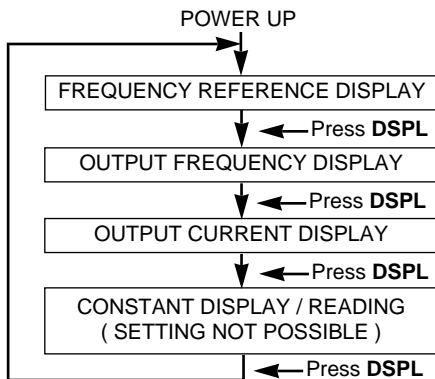

B) Frequency Reference Display.

F 0 6 0 . 0

Frequency reference is displayed in units of 0.1 Hz. See paragraph 1.7 to change frequency reference.

C) Output Frequency Display.

- 0 6 0 . 0

Output frequency is displayed in units of 0.1 Hz. The far left digit indicates the rotating direction while running (blank = forward; " - " = reverse).

D) Output Current Display.

1 0 . 0 A

Output current is displayed in units of 0.1 Amp.

2.3 PROGRAM MODE OPERATION.

IMPORTANT

Constant **no-00** determines which constants can be read or set. Therefore, it should always be the first constant read, and set if necessary.

Constants are read/set in the Program mode by the following procedures:

1. Press the **PRGM/DRIVE** key during stop to enter the Program mode.
2. Press **▲** or **▼** key to select the constant number to be read/set.
3. Press the **DATA/ENTER** key and the selected constant data are displayed.
4. Press **▶/RESET**, **▲** or **▼** key to set the data.

- To change the sign of data (constant *no-23* only), press **▲** or **▼** key when the far left digit is selected.

Minus data: Far left digit = "-"
 Plus data: Far left digit is blank

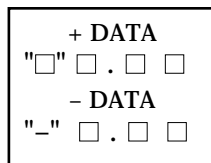

5. Press the **DATA/ENTER** key to write-in the data. If the set value exceeds the setting range, the whole display blinks for 3 seconds, then the original value is again displayed. When the set value is within the setting range, "**End**" will appear on the Digital Display for 1 second, then the new set value is displayed.
6. Press the **DSPL** key to display the constant number again.
7. Repeat steps 2-5 to read/set other constants.
8. When finished with constant programming, press the **PRGM/DRIVE** key to return to Drive mode.

Displays appearing only on the Digital Operator:

CONSTANT STATUS	MONITOR DISPLAY	RESULT
Accepted	" End " (1 sec)	Indicates constant setting was written into EEPROM.
Not accepted	Blinking for 3 seconds, then return to former data display	Indicates constant setting was not written into EEPROM.

SECTION 3 PROGRAMMABLE FEATURES

3.1 GENERAL. Paragraphs in this section provide a description of the GPD 333 features which are defined by programmed settings in memory. These feature descriptions appear in numerical order by constant number, based on 2-Wire factory reset.

GPD 333 Constants

CONSTANT	SETTING RANGE AND (UNIT) (NOTE 3)	INCREMENT	FACT. SET (NOTE 3)	REF PARA.
no-00 Password / Initialization	00 - 09	1	01	3.2
no-01 Operation Signal Selection 1	FOUR DIGIT BINARY CODE	---	0000	3.3
no-02 Maximum Frequency (Fmax)	50.0 - 400.0 (Hz)	.1	60.0	3.4
no-03 Maximum Voltage (Vmax)	0.1 - 255.0 (V)	.1	230.0	3.4
	0.1 - 510.0 (V)		460.0	
no-04 Max. Voltage Frequency (Fa)	0.2 - 400.0 (Hz)	.1	60.0	3.4
no-05 Frequency Midpoint (Fb)	0.1 - 399.9 (Hz)	.1	1.5	3.4
no-06 Voltage Midpoint (Vc)	0.1- 255.0 (V)	.1	12.0	3.4
	0.1- 510.0 (V)		24.0	
no-07 Min. Output Frequency (Fmin)	0.1- 10.0 (Hz)	.1	1.5	3.4
no-08 Min. Output Freq. Voltage (Vmin)	0.1 - 50.0 (V)	.1	12.0	3.4
	0.1 - 100.0 (V)		24.0	
no-09 Accel Time 1	0.0 - 600.0 (s)	.1	10.0	3.5
no-10 Decel Time 1	0.0 - 600.0 (s)	.1	10.0	3.5
no-11 Accel Time 2	0.0 - 600.0 (s)	.1	10.0	3.5
no-12 Decel Time 2	0.0 - 600.0 (s)	.1	10.0	3.5
no-13 Frequency Reference 1	0.0 - 400.0 (Hz)	.1	0.0	3.6
no-14 Frequency Reference 2	0.0 - 400.0 (Hz)	.1	0.0	3.6
no-15 Frequency Reference 3	0.0 - 400.0 (Hz)	.1	0.0	3.6
no-16 Frequency Reference 4	0.0 - 400.0 (Hz)	.1	0.0	3.6
no-17 Jog Frequency Reference	0.0 - 400.0 (Hz)	.1	6.0	3.6
no-18 Motor Protection Selection	FOUR DIGIT BINARY CODE	---	0000	3.7

GPD 333 Constants - Continued

DATA NAME	SETTING RANGE AND (UNIT) (NOTE 3)	INCREMENT	FACT. SET (NOTE 3)	REF PARA.
no-19 Motor Rated Current (See Note 1)	(10% to 120% of GPD 333 Rated Output Current)	.1 Amp	See Para. 3.8	3.8
no-20 Operation Selection Signal 2	FOUR DIGIT BINARY CODE	---	0000	3.9
no-21 Output Monitor Selection / S-Curve	FOUR DIGIT BINARY CODE	---	0000	3.10
no-22 Freq. Command Gain	0.01 - 2.00	.01	1.00	3.11
no-23 Freq. Command Bias (See Note 2)	- 1.00 - 1.00	.01	0.00	3.11
no-24 Freq. Command Upper Limit	0 - 110 (%)	1	100	3.11
no-25 Freq. Command Lower Limit	0 - 110 (%)	1	0	3.11
no-26 DC Injection Braking Current	0 - 100 (%)	1	50	3.12
no-27 DC Injection Braking Time at Stop	0.0 - 5.0 (s)	.1	0.0	3.12
no-28 DC Injection Braking Time at Start	0.0 - 5.0 (s)	.1	0.0	3.12
no-29 Automatic Torque Boost Gain	0.0 - 3.0	.1	1.0	3.13
no-30 Stall Prevention Level During Accel	30 - 200 (%)	1	170	3.14
no-31 Stall Prevention Level at Set Speed	30 - 200 (%)	1	160	3.14
no-32 Multi-function Input – Terminal 3	00 - 13	1	13	3.15
no-33 Multi-function Input – Terminal 4	01 - 13	1	01	3.15
no-34 Multi-function Input – Terminal 5	01 - 14	1	03	3.15
no-35 Multi-function Analog Input	00 - 04	1	00	3.16
no-36 Multi-function Output Relay	00 - 10	1	05	3.17
no-37 Multi-function Output – Terminal 13	00 - 10	1	00	3.18
no-38 Multi-function Output – Terminal 14	00 - 10	1	01	3.18
no-39 Frequency Detection Level	0.0 - 400.0 (Hz)	.1	0.0	3.19
no-40 Overtorque Detection Function Select	FOUR DIGIT BINARY CODE	---	0000	3.20
no-41 Overtorque Detection Level	30 - 200 (%)	1	160	3.20
no-42 Overtorque Detection Time	0.1 - 10.0 (s)	.1	0.1	3.20
no-43 Carrier Frequency	1 - 6 (x 2.5 kHz)	1	4	3.21, 1.4.4

GPD 333 Constants - Continued

CONSTANT	SETTING RANGE AND (UNIT) (NOTE 3)	INCREMENT	FACT. SET (NOTE 3)	REF PARA.
no-44 NOT USED	---	---	---	---
no-45 Analog Monitor Gain	0.01 - 2.00	.01	1.00	3.10
no-46 Momentary Power Loss Function Selection	FOUR DIGIT BINARY CODE	---	0000	3.22
no-47 No. of Auto-restart Attempts	0 - 10	1	0	3.23
no-48 Fault Record	N/A	N/A	N/A	3.24
no-49 PROM No.	N/A	N/A	N/A	3.25
no-50 Prohibited Frequency	0.0 - 400.0 (Hz)	0.1	0.0	3.26
no-51 Prohibited Frequency Deadband	0.0 - 25.5 (Hz)	0.1	1.0	3.26
no-52 thru no-59 NOT USED	---	---	---	---

NOTES:

1. Initial value depends upon GPD 333 Capacity. See paragraph 3-8.
2. To change to negative setting, select the far left digit ("X" X . X X). Press ▲ key to change it to "-".
3. Where two setting ranges and two factory settings are listed for a constant, the upper ones are for a 230V drive and the lower ones are for a 460V drive.

3.2 PASSWORD / INITIALIZATION

Constant no-00 This constant determines which of the constants can be examined in the Drive mode, and read/set in the Program mode. Factory Setting : 01

SETTING	FUNCTION
00	Password reading / setting enabled (constant no-00); constants no-01 thru no-19 can be read only
01	Constants no-00 thru no-19 can be read / set; no other constants can be read / set (NOTE: this is factory setting)
02	Constants no-00 thru no-29 can be read / set; no other constants can be read / set
03	Constants no-00 thru no-59 can all be read / set
04	NOT USED
05	NOT USED
06	Clear Fault Record (then return to factory setting)
07	NOT USED
08	Initialization for 2-Wire Control (then return to factory setting)
09	Initialization for 3-Wire Control (then return to factory setting)

When **06** is entered, the GPD 333's internal fault record is cleared; then the setting value automatically returns to **01** .

When either **08** or **09** is entered (initialization settings), the definitions of inputs at terminals 1 – 5 are changed. Constants **no-32, no-33 & no-34**, (Multi-function Input - Terminal 3, 4 & 5) settings are also changed, according to the requirements of the control configuration (see Figures 1-5 and 1-6). All other constants are returned to FACTORY SETTINGS; constant **no-00** setting then returns to **01**.

3.3 OPERATION SIGNAL SELECTION 1

Constant no-01 This four-digit binary code determines the source of frequency reference, Run/Stop signals, the method of stopping the motor when the Stop command is issued, and whether the output voltage limiter is enabled or disabled. Factory Setting : 0000

DIGIT	FUNCTION
X X X <u>X</u>	0 = External frequency reference (0-10Vdc or 4-20mA) (Term. 8 or 9)
	1 = Internal Frequency Reference (set by Digital Operator)
X X <u>X</u> X	0 = External Run / Stop commands
	1 = Run / Stop by Digital Operator
X <u>X</u> X X	0 = Ramp to stop at Stop command
	1 = Coast stop at Stop command
<u>X</u> X X X	0 = V/f with output voltage limiter
	1 = V/f without output voltage limiter

Note: If X X X X is set to 1, the V/f pattern (see paragraph 3.4) must be set to match motor data.

3.4 V/f PATTERN

Constants

no-02 thru *no-08*

These constants define the V/f pattern, and are related to each other as shown below.

CONSTANT	DATA NAME	SETTING RANGE (NOTE 1)	FACTORY SETTING (NOTE 1)
<i>no-02</i>	Maximum Frequency (Fmax)	50.0 - 400.0 (Hz)	60.0
<i>no-03</i>	Maximum Voltage (Vmax)	0.1 - 255.0 (V)	230.0
		0.1 - 510.0 (V)	460.0
<i>no-04</i>	Maximum Voltage Frequency (Fa)	0.2 - 400.0 (Hz)	60.0
<i>no-05</i>	Frequency Midpoint (Fb)	0.1 - 399.9 (Hz)	1.5
<i>no-06</i>	Voltage Midpoint (Vc)	0.1 - 255.0 (V)	12.0
		0.1 - 510.0 (V)	24.0
<i>no-07</i>	Minimum Output Frequency (Fmin)	0.1 - 10.0 (Hz)	1.5
<i>no-08</i>	Minimum Output Frequency Voltage (Vmin)	0.1 - 50.0 (V)	12.0
		0.1 - 100.0 (V)	24.0

NOTES:

1. Where two setting ranges and two factory settings are listed for a constant, the upper ones are for a 230V drive and the

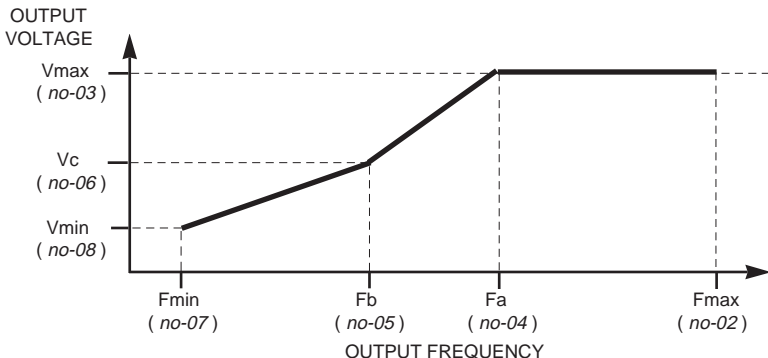

To establish a V/f pattern with a straight line from Fmin to Fa, set Fb = Fmin, and Vc = Vmin.

IMPORTANT

When entering a setting for one of these constants, an improper constant fault will occur if any part of the following relationships among constants **no-02** thru **no-08** is NOT TRUE:

- a) $F_{max} \geq F_a \geq F_b \geq F_{min}$
- b) $V_{max} > V_c \geq V_{min}$

The attempted setting value will blink for approx. 3 seconds, then the display will again show the previous constant setting.

3.5 ACCEL / DECEL TIMES

Constants

no-09	Accel Time 1	Range (ea.): 0.0 to 600.0 (s)
no-10	Decel Time 1	Factory Setting (ea.): 10.0

These constants set the normal accel and decel times required for the GPD 333 output to ramp from Fmin to Fmax or from Fmax to Fmin, respectively.

Constants

no-11	Accel Time 2	Range (ea.): 0.0 to 600.0 (s)
no-12	Decel Time 2	Factory Setting (ea.): 10.0

If a Multi-function Input (terminal 3, 4 or 5) is programmed as Accel/Decel Time Change command (see paragraph 3.15), the GPD 333 uses the settings in *these* constants as its accel and decel times when that input is closed.

3.6 MULTI-STEP SPEED PRESETS

Constants

no-13 thru *no-17*

Range (ea.) : 0.0 to 400.0 (Hz)

Factory Settings : *no-17* = 6.0;
all others = 0.0

In order to use multi-step speed presets, constants *no-32*, *no-33* & *no-34* must be programmed accordingly for 2-Wire or 3-Wire control. (Constant *no-01* must be set to X X X 1.)

To use the maximum of 5 preset speeds (in 2-Wire control only), constant *no-32* must be set to **03** (Multi-step Speed Ref 1), constant *no-33* must be set to **04** (Multi-step Speed Ref 2), and constant *no-34* must be set to **05** (Jog).

Multi-step (5 preset speeds) in 2-Wire control

CONSTANT and NAME	EXTERNAL TERMINAL		
	5	4	3
<i>no-13</i> Frequency Ref 1	0	0	0
<i>no-14</i> Frequency Ref 2	0	0	1
<i>no-15</i> Frequency Ref 3	0	1	0
<i>no-16</i> Frequency Ref 4	0	1	1
<i>no-17</i> Jog Reference	1	0	0

1 = Closed (ref terminal 6) 0 = Open (ref terminal 6)
In Drive mode, each Frequency Ref setting can be changed on the fly, while selected by input commands, by use of the Frequency Reference display (see paragraph 1.7).

For 3-Wire control, constant *no-32* must be **00** (FWD/REV). Therefore, a maximum of 4 preset speeds can be used, if constant *no-33* is set to **03** (Multi-step Speed Ref 1) and constant *no-34* is set to **04** (Multi-step Speed Ref 2).

Multi-step (4 preset speeds) in 3-Wire control

CONSTANT and NAME	EXTERNAL TERMINAL	
	5	4
<i>no-13</i> Frequency Ref 1	0	0
<i>no-14</i> Frequency Ref 2	0	1
<i>no-15</i> Frequency Ref 3	1	0
<i>no-16</i> Frequency Ref 4	1	1

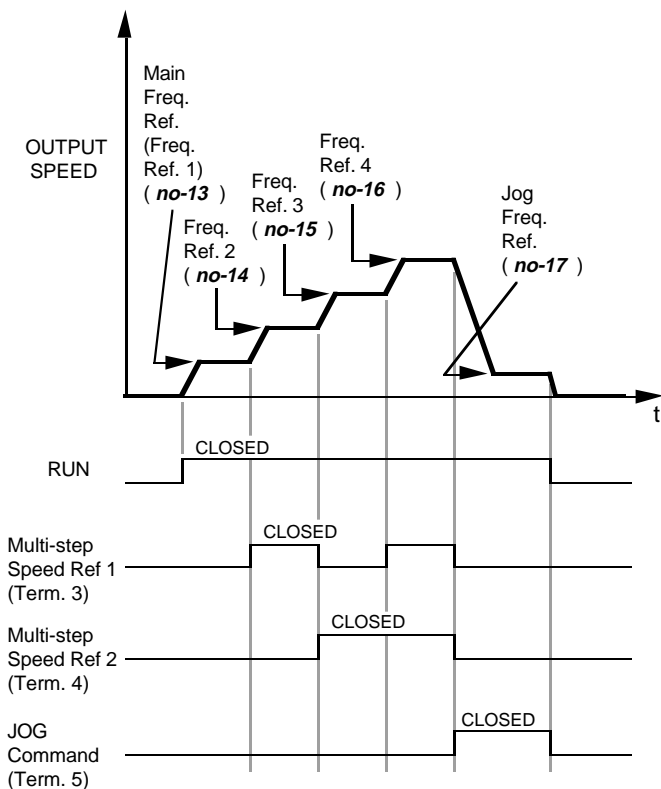

NOTE: The JOG command takes priority over multi-step speed select inputs.

**Typical Multi-step Speed Operation
(2-Wire Control Example)**

3.7 MOTOR PROTECTION SELECTION

Constant no-18 This four-digit binary code determines whether thermal overload protection is provided for the motor and whether it is for constant or variable torque load. Factory Setting : 0000

DIGIT	FUNCTION
X X X <u>X</u>	0 = Electronic thermal overload motor protection enabled
	1 = Electronic thermal overload motor protection disabled
X X <u>X</u> X	0 = Electronic thermal overload is for variable torque
	1 = Electronic thermal overload is for constant torque
<u>X</u> X X X	NOT USED

3.8 MOTOR RATED CURRENT

Constant no-19 Factory set according to the horsepower rating of the GPD 333. Should be set according to user's motor. Range (in Amps) : From 10% to 120% of drive's continuous output current rating. Increment: .1 Amp

Motor Rated Current Settings

The motor rated current setting is used by the electronic thermal overload circuit (if enabled; see paragraph 3.7) to protect the motor by means of **oL1** fault shutdown.

INPUT VOLTS	HORSEPOWER ¹	GPD 333 CONTINUOUS OUTPUT CURRENT 100% RATED AMPS	MOTOR RATED CURRENT - AMPS (CONSTANT no-19) FACTORY SETTING
2 3 0	1/4	1.5	1.1
	3/4	3	1.9
	1	5	3.3
	1.5	6.5	6.2
	3	11	8.5
	5	17.5	14.1
4 6 0	1/2	1	0.6
	3/4	1.6	1.0
	1.5	2.6	1.6
	2	4	3.1
	3	4.8	4.2
	5	8	7.0

¹ A standard 4-pole motor is used to determine applicable motor horsepower.

3.9 OPERATION SIGNAL SELECTION 2

Constant
no-20

Factory Setting : 0000

This four-digit binary code determines reverse run capability and decel stall prevention.

DIGIT	FUNCTION
X X X <u>X</u>	0 = Reverse run enabled 1 = Reverse run disabled
X <u>X</u> X X	NOT USED
<u>X</u> X X X	0 = Stall prevention during deceleration enabled 1 = Stall prevention during deceleration disabled (braking resistor connected)

Stall prevention during deceleration automatically adjusts the deceleration rate while monitoring the DC bus voltage to prevent overvoltage during deceleration. This digit must be set to 1 when connecting dynamic braking (DB) resistor.

When the motor load is larger or decel time is shorter, decel time may be longer than the set value because of the stall preventive function.

3.10 OUTPUT MONITORING

Constant
no-21

Output Monitor Selection

Factory
Setting : 0000

This four-digit binary code establishes which output parameter will be applied to the Analog Monitor Output

DIGIT	FUNCTION
X X X <u>X</u>	NOT USED
X X <u>X</u> X	0 = Analog monitor output : output frequency 1 = Analog monitor display : output current
X <u>X</u> X X	S-Curve Accel/Decel Selection: 0 = Not Provided; 1 = .2 sec. S-curve
<u>X</u> X X X	NOT USED

at terminals 12 & 11, and whether S-Curve is provided (see illustration on next page).

The Analog Monitor output is a 0-10Vdc signal, proportional to the output parameter selected.

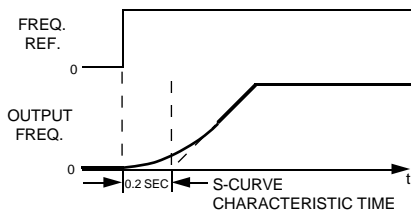

Note: S-Curve characteristic time refers to the time from the acceleration rate 0 to regular acceleration rate determined by the set acceleration time. It can reduce shock while a machine is starting or stopping

Constant **Analog Monitor Gain**
no-45

Range : 0.01 to 2.00
Factory Setting : 1.00

This constant calibrates the output signal for the external metering circuit.

3.11 FREQUENCY COMMAND

Constant **Frequency Command Gain**
no-22

Range : 0.01 to 2.00
Factory Setting : 1.00

Sets the External Speed Frequency Reference gain, in increments of 0.01.

Constant **Frequency Command Bias**
no-23

Range : -1.00 to (+)1.00
Factory Setting : 0.00

Sets the External Speed Frequency Reference bias, in increments of 0.01.

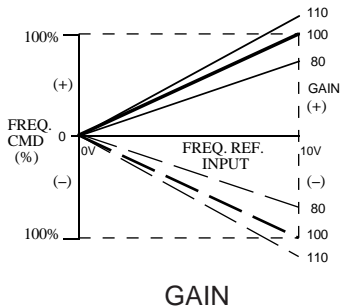
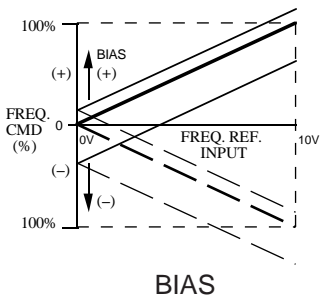

Constants

no-24 **Frequency Command Upper Limit** Range (ea.) :
0 to 110 (%)

no-25 **Frequency Command Lower Limit** Factory Settings :
no-24 = 100 ;
no-25 = 0

Both constants set the range for the frequency command signal. Each is set as a percentage of maximum frequency (Fmax) as established by the setting of constant **no-02** (see paragraph 3.4). All references are affected by the upper and lower limit.

EXAMPLE:

- Constant **no-02** = 60 (Hz) (100%)
- Constant **no-24** = 80 (%) = 48Hz
- Constant **no-25** = 10 (%) = 6Hz

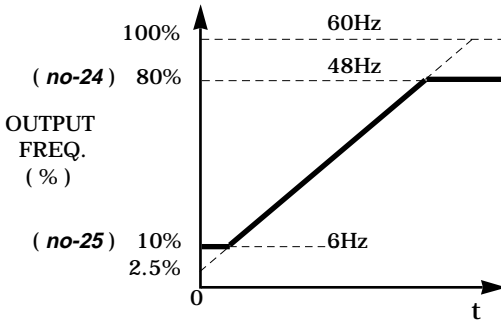

3.12 DC INJECTION BRAKING

Constant **DC Injection** Range : 0.0 to 100.0 (%)
no-26 **Braking Current** Factory Setting : 50.0

Limits the DC current level that the GPD 333 produces at DC braking time. Time and current level must be set to provide adequate stopping without excessive motor heating.

Constant **DC Injection Braking** Range : 0.0 to 5.0 (s)
no-27 **Time at Stopping** Factory Setting : 0.0

Sets the time, in increments of 0.1 second, during which DC injection braking current is applied at ramp to stop. This time starts when output frequency reaches Fmin (constant **no-07**). If set to zero, then operation is coast stop after Fmin. This function is disabled if coast stop is enabled in constant **no-01** .

Constant **DC Injection Braking** Range : 0.0 to 5.0 (s)
no-28 **Time at Starting** Factory Setting : 0.0

Sets the time, in increments of 0.1 second, during which DC injection braking current is applied at starting (by inputting a Forward or Reverse run command). When set to zero, acceleration begins immediately with the minimum output frequency.

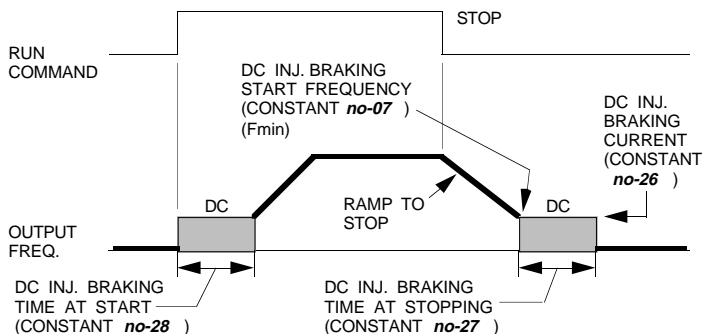

3.13 AUTOMATIC TORQUE BOOST GAIN

Constant no-29 Sets the torque compensation, in increments of 0.1. Range : 0.0 to 3.0
Factory Setting : 1.0

When the motor has the same capacity as that of the GPD 333, the gain is 1.0. When a smaller motor is used, the gain should be set to 1.5 (typical). Except for the most demanding of high torque applications, the factory setting of this constant will be adequate. The factory setting is programmed to match the performance characteristics of typical AC motors.

3.14 STALL PREVENTION automatically adjusts output frequency according to the load so as to continue operation of the machine without stalling the motor.

Constant no-30 **Stall Prevention Level During Accel** Range : 30 to 200 (%)
Factory Setting : 170

Determines the actual GPD 333 output current level during an accelerating condition. Set in percent of GPD 333 rated output current (see paragraph 3.8).

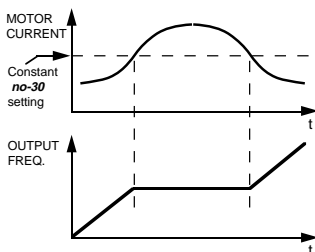

Constant no-31 **Stall Prevention Level at Set Speed** Range : 30 to 200 (%)
Factory Setting : 160

Determines the actual output current level of the GPD 333 while operating at set speed (frequency). Also set in percent of GPD 333 rated output current (see paragraph 3.8).

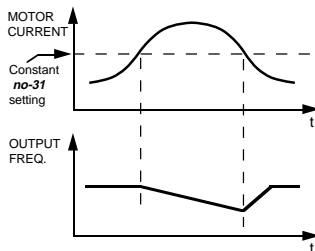

3.15 MULTI-FUNCTION INPUTS

Constants	Multi-function Input	Factory Settings	
		2-Wire	3-Wire
<i>no-32</i>	<i>Terminal 3</i>	13	00
<i>no-33</i>	<i>Terminal 4</i>	01	01
<i>no-34</i>	<i>Terminal 5</i>	03	03

Inputs to these three terminals are defined by these constants. When a terminal is closed to sequence common (term. 6), the selected function is enabled. To disable the function, the input must be opened.

SETTING	FUNCTION
00	Fwd / Rev Select Command; Open = Fwd , Closed = Rev (for 3-Wire control configuration)
01	External Fault (NO contact input)
02	External Fault (NC contact input)
03	Multi-step Speed Ref 1
04	Multi-step Speed Ref 2
05	Jog
06	Accel / Decel Time Change
07	External Baseblock (NO contact input)
08	External Baseblock (NC contact input)
09	Speed Search from max freq.
10	Speed Search from set freq.
11	Accel / Decel Prohibit
12	Local / Remote
13	Fault Reset
14	Up / Down Function

IMPORTANT

- Program ONLY ONE of the multi-function terminals for speed search; a second speed search setting will not be accepted.
- No two of the above constants can have the same setting value entered.
- Constants *no-32* and *no-33* cannot be set to **14** .
- When constant *no-34* is set to **14** (Up / Down), terminal 4 becomes the UP command input and terminal 5 becomes the DOWN command input, regardless of the previous setting in constant *no-33*.

3.16 MULTI-FUNCTION ANALOG INPUT

Constant
no-35

Factory Setting : 00

IMPORTANT: An optional Analog Input PCB is required for operation using analog input.

Programming this constant per the chart below configures the optional Analog Input PCB for analog control. The four figures show how each setting configures the analog input.

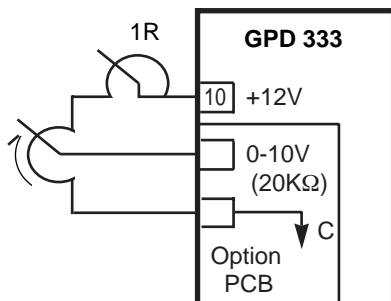

SETTING	FUNCTION	REMARKS
00	Option PCB not present	Factory setting
01	Manual Reference	External reference input
02	Frequency Reference Gain (FGAINE)	Total gain = Internal gain (no-22) x FGAINE
03	Frequency Reference Bias (FBIAS) (+/−) *	Total bias = Internal bias (no-23) + FBIAS
04	VBIAS	VBIAS addition after V/f conversion

no-35 = 01

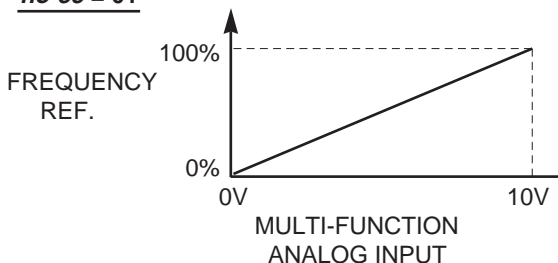

no-35 = 02

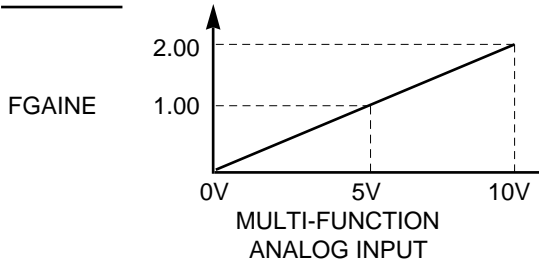

no-35 = 03

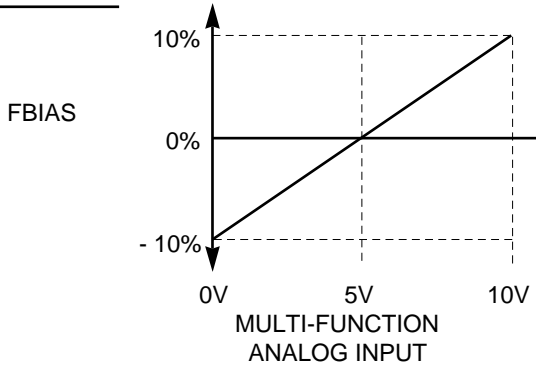

no-35 = 04

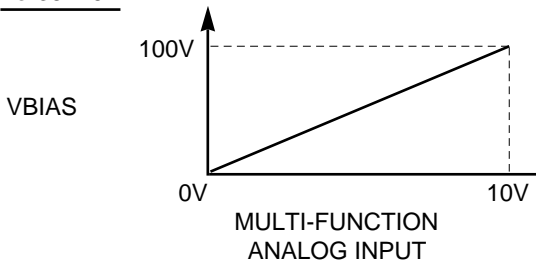

3.17 MULTI-FUNCTION OUTPUT RELAY

Constant
no-36

Factory Setting : 05

This relay can be programmed to change state upon any of the conditions listed below.

Relay contacts are Form-C.

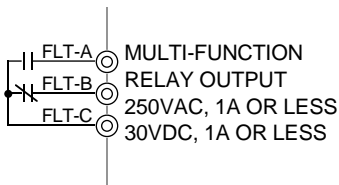

SETTING	FUNCTION
00	Running
01	Speed at set frequency
02	Zero speed
03	Frequency detection (output frequency > or = constant no-39 setting)
04	Overtorque detection
05	Fault output
06	Frequency detection (output frequency < or = constant no-39 setting)
07	During base block
08	During undervoltage (UV)
09	During speed search
10	In Local operating mode (selected by "LOC / RMT" key of Digital Operator)

3.18 MULTI-FUNCTION OUTPUTS

Constants

no-37
and
no-38

**Multi-function Output 1 -
Terminal 13 (ref term. 7)**
**Multi-function Output 2 -
Terminal 14 (ref term. 7)**

Factory Settings :

no-37 = 00
no-38 = 01

Multi-function output terminals 13 & 14 are defined by the settings of these two constants. Each open collector output will switch low (with respect to terminal 7, common) when the selected condition is met.

SETTING	FUNCTION
00	Running
01	Speed at set frequency
02	Zero speed
03	Frequency detection (output frequency > or = constant no-39 setting)
04	Overtorque detection
05	Fault output
06	Frequency detection (output frequency < or = constant no-39 setting)
07	During base block
08	During undervoltage (UV)
09	During speed search
10	In Local operating mode (selected by "LOC / RMT" key of Digital Operator)

Multi-function Output Terminals

Recommended Configuration for DC Relays

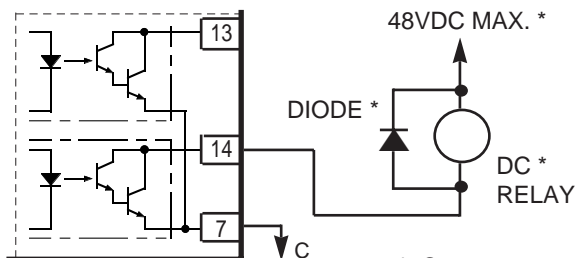

* Customer supplied

3.19 FREQUENCY DETECTION LEVEL

Constant no-39 Establishes the frequency level used as a reference when

Range : 0.0 to 400.0 (Hz)
 Factory Setting : 0.0

programming a multi-function output terminal or contact to change state at Frequency Detection (see paragraphs 3.17 and 3.18).

3.20 OVERTORQUE DETECTION. Overtorque detection compares GPD 333 rated output current with the overtorque detection level. When the output current is equal to or greater than the detection level, an **oL3** fault or warning on the Digital Operator or status LEDs. (The detection level is a percent of GPD 333 rated output current; see paragraph 3.8.)

Constant no-40 **Overtorque Detection Function Selection** Factory Setting : 0000

This four-digit binary code determines how the overtorque detection function of the GPD 333 will operate. See Timing Diagram.

DIGIT	FUNCTION
X X X <u>X</u>	0 = Overtorque detection function disabled
	1 = Overtorque detection function enabled
X X <u>X</u> 1	0 = Overtorque detection only when output is at set frequency
	1 = Overtorque detection at all times (except during stopping or DC injection braking)
X <u>X</u> X 1	0 = Operation continues after overtorque detection
	1 = Coast stop after overtorque detection
<u>X</u> X X X	NOT USED

NOTE: Descriptions of constants **no-41** and **no-42** follow the timing diagram.

EXAMPLE:

Constant **no-38** = 04 (See paragraph 3.18)

Constant **no-40** = 0101 ; Overtorque enabled, only
at set frequency, coast to stop

Constant **no-41** = 160 (%)

Constant **no-42** = 1.0 (s)

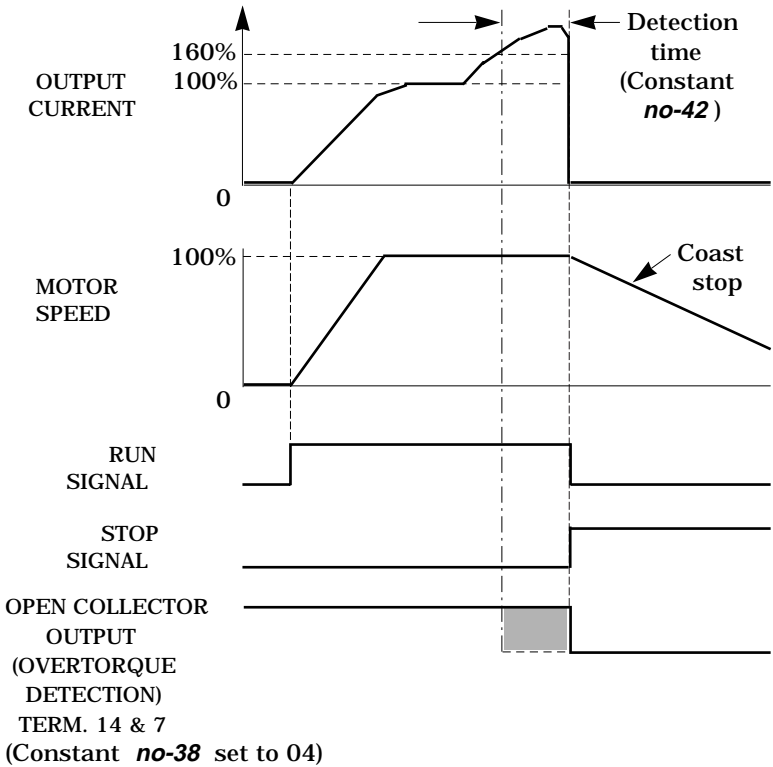

Overtorque Detection Timing Diagram

3.20 OVERTORQUE DETECTION – CONTINUED

Constant **Overtorque Detection** Range : 30 to 200 (%)
no-41 **Level** Factory Setting : 160

This is the reference

point for determining that an overtorque condition exists. Set as a percent of GPD 333 rated current (see paragraph 3.8).

Constant **Overtorque Detection** Range : 0.1 to 10.0 (s)
no-42 **Time** Factory Setting : 0.1

Determines how long

an overtorque condition must exist before another event will occur, i.e. coast stop, multi-function output change of state, or **oL3** warning or fault displayed.

3.21 CARRIER FREQUENCY

Constant Range : 1 to 6 (x 2.5 kHz)
no-43 Factory Setting : 4 (= 10 kHz)

The user can select a higher or lower carrier frequency, depending on allowable operating noise levels for the application. Adjusts in increments of 2.5 kHz (set value x 2.5 kHz = carrier frequency).

NOTE: Also see paragraph 1.4.4.

IMPORTANT: Setting **5** or **6** will reduce maximum continuous output current of the GPD 333.

SETTING	MAXIMUM CONTINUOUS OUTPUT CURRENT
1 to 4	Up to 100% of GPD 333 output current
5	Up to 90% of GPD 333 output current
6	Up to 80% of GPD 333 output current

- Constant *no-44* : NOT USED.
- Constant *no-45* : see paragraph 3.10.

3.22 MOMENTARY POWER LOSS RIDE-THRU

Constant **Momentary Power Loss** Factory Setting : 0000
no-46 **Function Selection**

This four-digit binary code determines how the momentary power loss ride-thru function of the GPD 333 will function.

DIGIT	FUNCTION
X X X <u>X</u>	0 = Operation during momentary power loss disabled
	1 = Operation during momentary power loss enabled 1/4-1 HP : 1 sec. power loss ride-thru 2-5 HP : 2 sec. power loss ride-thru
<u>X</u> X X X	Not Used

3.23 NO. OF AUTO-RESTART ATTEMPTS

Constant GPD 333 can be programmed Range : 0 to 10
no-47 for an auto-restart operation Factory Setting : 0
to automatically reset a fault

which occurs during operation. Auto-restart operation will use the number of restart attempts set in this constant, up to the maximum of ten. When set to **0**, no auto-restart will be attempted.

- Only the following faults can be automatically reset:
 - oC: Overcurrent oH: Overheat
 - ou: Overvoltage (OV) GF: Ground Fault
- The number of restart attempts available will reset to the constant **no-47** setting when:
 1. 10 minutes have elapsed without a fault occurring.
 2. An external Fault Reset push button is pressed (or the **RESET** key of optional Digital Operator is pressed).
 3. The power supply is turned off long enough for the GPD 333 to re-initialize itself when power is returned.

3.24 FAULT RECORD

Constant Display-only function which cannot be programmed by the user. When this constant
no-48 number is selected and the **DATA/ENTER** key is pressed, the fault code for the most recent fault is displayed.

Only the following types of faults can be stored in the fault record: **oC** (overcurrent), **ou** (overvoltage), **oH** (cooling fin over-heat), **oL1** (motor overload), **oL2** (drive overload), **oL3** (over-torque detection), **EF4**, **EF5** (external fault), or **CPF05** (A/D converter fault).

To clear the fault record, enter setting **6** into constant *no. 00* .

NOTE: The fault record is also cleared automatically when an initialization setting is entered into constant *no. 00* .

3.25 PROM NO.

Constant Display-only function which cannot be programmed by the user. When this constant
no-49 number is selected and the **DATA/ENTER** key is pressed, the code number (5 digits) of the PROM that is installed on the Control PC board is displayed.

3.26 CRITICAL FREQUENCY REJECTION

Constants	Prohibited	Range : 0.0 to 400.0 (Hz)
<i>no-50</i>	Frequency	Factory Setting : 0.0

Allows programming of one prohibited frequency point, in increments of 0.1 Hz, for eliminating problems with resonant vibration of the motor/machine. This feature does not actually eliminate the selected frequency values, but will accelerate and decelerate the motor through the prohibited bandwidth.

Constant	Prohibited Frequency	Range : 0.0 to 25.5 (Hz)
<i>no-51</i>	Deadband	Factory Setting : 1.0

Determines the width of the deadband, in increments of 0.1 Hz, around the prohibited frequency point. The factory setting of **1.0** establishes a deadband of ± 1.0 Hz.

EXAMPLE: Vibration encountered between 30.0 and 36.0 Hz.

SOLUTION:

Set constant **no-50** to **33.0**. This is the center of the problem frequency band.

Set constant **no-51** to **3.0**. This will cause the GPD 333 to reject all frequency command values between 30.0 and 36.0 Hz.

A frequency command in the deadband will be converted to the bottom value of the deadband, e.g. a command of 33 Hz would result in a run frequency of 30 Hz.

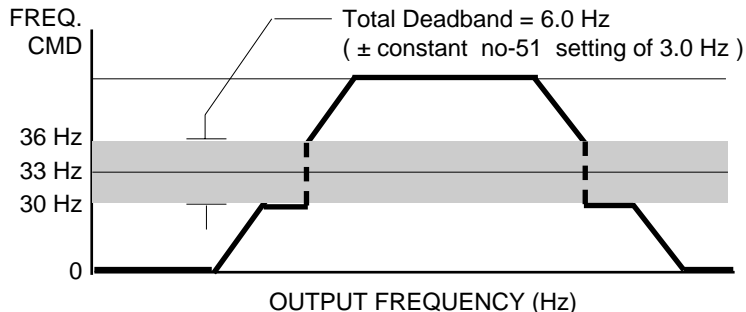

This page intentionally left blank.

SECTION 4 FAULT/WARNING FUNCTIONS

4.1 GENERAL. The GPD 333's Fault circuit monitors operating parameters and initiates drive shutdown (Fault contacts change state) when allowable limits are exceeded, or provides a warning indication when conditions exist which may lead to a Fault shutdown. The status LEDs on the front of the GPD 333, or the 5-digit display on the Digital Operator (when present), provides a coded display related to the Fault or Warning Function which has occurred.

4.2 TROUBLESHOOTING. If a fault shutdown of the GPD 333 has occurred, observe the LED indication or Digital Operator display; find the same indication or display in the Fault Functions or Warning Functions table, and take the appropriate corrective action based on the description given.

WARNING

Oscilloscope chassis may be at voltages potentially hazardous to life if not properly grounded. If oscilloscope is used to measure high voltage waveforms, use only a dual channel oscilloscope in the differential mode with X100 probes. Always connect oscilloscope chassis to earth ground.

WARNING

Voltages dangerous to life exist when equipment is open and energized. Do not work alone.

CAUTION

To prevent equipment damage always remove incoming three-phase power before test equipment is connected or removed.

4.3 FAULT FUNCTIONS.

FUNCTION	STATUS LEDS		DIGITAL OPERATOR DISPLAY	DESCRIPTION
	DS1 (GRN)	DS2 (RED)		
Undervoltage	Off	LIT	<i>U u I</i>	GPD 333 drive shutdown; main circuit DC voltage was lower than 210V for 230V rated drive, or lower than 420V for 460V rated drive.
Overcurrent	Blinking	LIT	<i>o C</i>	GPD 333 drive shutdown; output current exceeded 200% of GPD 333 rated current.
Grounding	Blinking	LIT	<i>G F</i>	GPD 333 drive shutdown; grounding occurred at GPD 333 output side and grounding current flowed.
Overvoltage	Off	LIT	<i>o u</i>	GPD 333 drive shutdown; main circuit DC voltage exceeded 410V for 230V rated drive, or exceeded 820V for 460V rated drive.
Fuse Blown	Off	Off	No display	GPD 333 drive shutdown; blown fuse.
Fin Overheat	LIT	Blinking	<i>o H</i>	GPD 333 drive shutdown; thermistor exceeded rating.
Overload (Motor)	LIT	Blinking	<i>o L 1</i>	GPD 333 drive shutdown; electronic thermal overload detected.
Overload (Drive)	LIT	Blinking	<i>o L 2</i>	GPD 333 drive shutdown; electronic overload operated (at 150% for one minute).
Overload (Overtorque)	LIT	Blinking	<i>o L 3</i>	GPD 333 drive shutdown; overtorque detection programmed for shutdown (coast stop), and GPD 333 output current exceeded detection level (constant no-41) for longer than overtorque detection time (constant no-42).

4.3 FAULT FUNCTIONS – Continued

FUNCTION	STATUS LEDS		DIGITAL OPERATOR DISPLAY	DESCRIPTION
	DS1 (GRN)	DS2 (RED)		
External Fault Signal Input	Blinking	Blinking	<i>E F 3, 4 or 5</i>	GPD 333 drive shutdown; external fault signal input is present at control circuit terminal 3, 4 or 5.
Initial Memory Fault	Off	Off	<i>C P F 0 0</i>	GPD 333 Failure. *
Transmission Error	Off	Off	<i>C P F 0 1</i>	GPD 333 Failure. *
Improper Constant	LIT	LIT	<i>C P F 0 4</i>	GPD 333 CPU not properly initialized. *
A/D Converter Fault	LIT	LIT	<i>C P F 0 5</i>	GPD 333 Failure. *

- * Make sure that all constant settings have been recorded. Then enter an initialization setting into constant *no. 00*. Cycle power off and back on once to see if the CPF fault has cleared; if not, the drive must be replaced.

4.4 WARNING FUNCTIONS.

FUNCTION	STATUS LEDS		DIGITAL OPERATOR DISPLAY	DESCRIPTION
	DS1 (GRN)	DS2 (RED)		
Overtorque Detection	Off	Blinking	(Blinks) o L 3	Overtorque detection programmed to continue operation after overtorque detection, and GPD 333 output current has exceeded overtorque detection level for longer than overtorque detection time.
FWD / REV Simultaneous On	Off	Blinking	(Blinks) E F	Motor stops according to selected GPD 333 stopping method, when FWD RUN and REV RUN commands are closed at the same time. (If either input is removed, motor operation will resume.)
Undervoltage Display	Off	Blinking	(Blinks) U u	Displayed, while GPD 333 is in stopped condition, when main circuit DC voltage is less than 210V for 230V rated drive, or less than 420V for 460V rated drive.
External Base Block	Off	Blinking	(Blinks) b b	Displayed when external Base Block signal is applied. (Motor operation will resume when Base Block input is removed.)
Overvoltage	Off	Blinking	(Blinks) o u	Displayed, while GPD 333 is in stoped condition, when main circuit DC bus voltage is more than 410V for 230V rated drive, or more than 820V for 460V rated drive.
Overheat	Off	Blinking	(Blinks) o H	Displayed, while GPD 333 is in stopped condition, when thermistor has exceeded rating.

NOTE: A set of detailed fault troubleshooting flowcharts can be obtained from MagneTek, by sending in the reply card located inside the back cover of this manual. If the reply card has already been removed, contact your MagneTek sales representative for assistance.

GPD 333 SPECIFICATIONS For 230V Drives

MODEL DS _ _ _		020	021	022	029	023	024	025
Max. Applicable Motor HP (kW) (Note 1)		1/4 (0.2)	1/2 (0.6)	1 (0.75)	1.5 (1.1)	2 (1.5)	3 (2.2)	5 (3.7)
Weight Lb (kg)		2.43 (1.1)	2.43 (1.1)	4.41 (2.0)	4.41 (2.0)	4.41 (2.0)	13.23 (6.0)	13.23 (6.0)
MCCB Rated Current (A)		3	7	15	15	15	30	30
Cooling Method		Self-cooling					Forced fan cooling	
OUTPUT	Rated output capacity (kVA)	0.6	1.2	2	2.6	2.8	4.4	6.8
	Max. continuous output current (A)	1.5	3	5	6.5	7.3	11	17.5
	Max. output voltage	3-phase, 200 to 230V (Proportional to max. input voltage)						
	Max. output frequency	Up to 400Hz available by constant setting						
POWER SUPPLY	Rated voltage / rated frequency	3-phase, 200 / 208 / 230V, 50Hz, 200 / 208 / 220 / 230V, 60Hz						
	Allowable volt. variation	± 10 %						
	Allowable freq. variation	± 5 %						

GPD 333 SPECIFICATIONS For 460V Drives

MODEL DS _ _ _		040	041	042	043	044	045	
Max. Applicable Motor HP (kW) (Note 1)		1/4 (0.4)	3/4 (0.6)	1 (1.1)	2 (1.5)	3 (2.2)	5 (3.7)	
Weight Lb (kg)		6.61 (3.0)	6.61 (3.0)	6.61 (3.0)	6.61 (3.0)	13.23 (6.0)	13.23 (6.0)	
MCCB Rated Current (A)		3	3	7	7	7	15	
Cooling Method		Self-cooling					Fan	
OUTPUT	Rated output capacity (kVA)	0.9	1.4	2.2	3.4	4.1	6.9	
	Max. continuous output current (A)	1	1.6	2.6	4	4.8	8	
	Max. output voltage	3-phase, 380 to 460V (Proportional to max. input voltage)						
	Max. output frequency	Up to 400Hz available by constant setting						
POWER SUPPLY	Rated voltage / rated frequency	3-phase, 380 / 400 / 415 / 440 / 460V, 50/60Hz						
	Allowable volt. variation	± 10 %						
	Allowable freq. variation	± 5 %						

Notes:

1. A standard 4 pole motor is used for determination of maximum applicable motor horsepower.

GPD 333 SPECIFICATIONS – All Drives

CONTROL CHARACTERISTICS

- **Control Method:** Sine Wave PWM
- **Frequency Control Range:** 0.1-400Hz
- **Frequency Accuracy:** Digital Reference: 0.01% (-10 to +40°C); Analog Reference: 0.1% (25°C ±10°C)
- **Frequency Setting Resolution:** Digital Operator: 0.1Hz; Analog reference: 0.06Hz / 60Hz
- **Output Frequency Resolution:** 0.1Hz
- **Overload Rating:** 150% rated output current for one minute
- **Frequency Setting Signal:** 0 to +10Vdc (20K ohms); 4-20mA (250 ohms)
- **Accel / Decel Time:** 0.1-600 sec. (Accel and decel time set independently)
- **Braking Torque:** Approximately 20% (braking transistor built in). Up to 150% possible with braking resistor option.
- **Voltage/frequency Pattern:** Any desired program V/f pattern can be set
- **Stall Prevention Level:** Stall level can be adjusted

PROTECTIVE FUNCTIONS

- **Momentary Overcurrent:** Coast stop at approximately 200% rated current
- **Overload:** Coast stop at approximately 150% rated current for one minute
- **Motor Protection:** Protection by programmable electronic thermal overload
- **Overvoltage:** Coast stop at main circuit DC voltage of exceeding 410V for 230V drives, 820V for 460V drives
- **Undervoltage:** Coast stop at main circuit DC voltage below 210V for 230V drives, 420V for 460V drives
- **Momentary Power Loss:** Factory Setting: 15 ms; for 1/4-1HP, 1 sec. ride-thru when enabled; for 2-5HP, 2 sec. ride-thru when enabled
- **Radiation Fin Overheat:** Protection by thermistor (only in forced fan cooled drives)
- **Grounding Protection:** Protection by electronic circuit
- **Charging Display:** "CHARGE" lamp remains lit until main circuit DC voltage is 50V or less

GPD 333 SPECIFICATIONS – All Drives – Continued

OPERATIONAL SPECIFICATIONS

- **Input:**
 - Operation Signal:** 2-Wire or 3-Wire
 - External Fault:** Output stopped (coast stop) by external fault input (programmable)
 - Reset:** Fault reset input terminal (programmable)
 - Multi-step Speed Setting:** Up to 5 preset speeds can be used in 2-Wire control; up to 4 preset speeds in 3-Wire control
 - Multi-function Input Selection:** 15 functions can be selected (3 items) as multi-function input
- **Output:**
 - Operation Status (open collector output: Qty 2)**
One Form-C contact } 10 programmable functions can be selected
- **Built-in Functions:** Frequency reference bias & gain setting; frequency upper & lower limit setting; DC injection current setting at start & stop; analog monitor gain setting; speed search
- **Display Function:**
 - Analog Output Monitor (programmable):** 0-10Vdc output, proportional frequency or current
 - Digital Operator, Model DS039 (optional):** Setting frequency; programming constants; output current display; output frequency and rotating direction display; fault display

ENCLOSURE: NEMA 1

ENVIRONMENT

- **Location:** Indoor (no corrosive gasses or dust)
- **Ambient Temperature:** NEMA 1: -10° to +40°C (+14° to +104°F); Open chassis: -10° to +45°C (+14 to +113°F); (no freezing)
- **Storage Temperature:** -20° to +60°C (-4° to +140°F) temperature during shipping (for short period)
- **Humidity:** 90% RH (no condensation)
- **Vibration:** 1G at less than 20Hz; up to 0.2G at 20-50Hz

FRONT VIEW

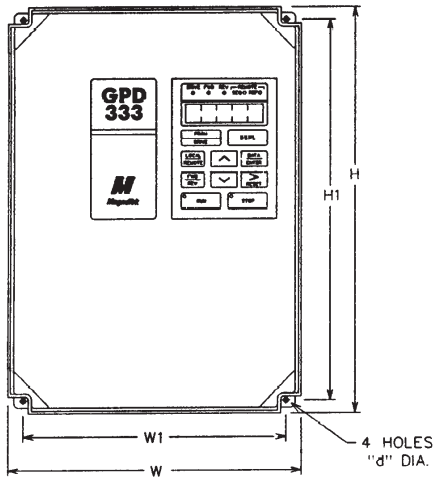

SIDE VIEW

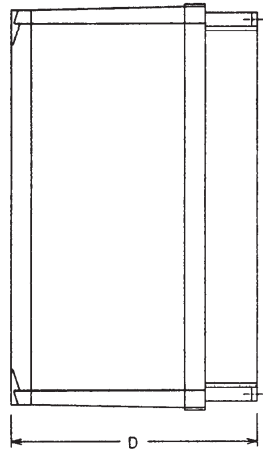

Rated Input	Model No. GPD333-	Dimensions in Inches (mm)						Approx. Weight lbs (kg)
		H	W	D	H1	W1	d	
230V	A0P3N4	6.77 (172)	4.45 (113)	4.07 (103.5)	5.43 (138)	3.66 (93)	0.16 (4)	4.4 (2.0)
	A0P7N4, A001N4	6.77 (172)	5.83 (148)	5.59 (142)	5.43 (138)	5.04 (128)	0.16 (4)	6.6 (3.0)
	A002N4, A003N4	8.94 (227)	5.83 (148)	6.83 (173.5)	7.32 (186)	4.96 (126)	0.16 (4)	8.8 (4.0)
	A005N4	9.06 (230)	7.87 (200)	7.62 (193.5)	7.28 (185)	6.89 (175)	0.16 (4)	13.2 (5.9)
460V	B0P5N4, B0P7N4	8.94 (227)	5.83 (148)	4.86 (123.5)	7.32 (186)	4.96 (126)	0.16 (4)	5.7 (2.6)
	B001N4, B002N4	8.94 (227)	5.83 (148)	6.83 (173.5)	7.32 (186)	4.96 (126)	0.16 (4)	8.8 (4.0)
	B003N4, B005N4	9.06 (230)	7.87 (200)	7.62 (193.5)	7.28 (185)	6.89 (175)	0.20 (5)	12.3 (5.5)

GPD 333 NEMA 4/12 Dimensions

The standard GPD 333 NEMA 4/12 models include the DS039 Digital Operator factory-installed, as shown on page 56. Additionally, all GPD 333 NEMA 4/12 drives are provided with fuses for customer mounting. Although the drives have built-in short circuit protection, these fuses are provided as additional personnel protection in the event of a catastrophic output shorting condition.

WARNING

Failure to utilize recommended input fusing could result in severe personal injury.

The following table provides recommended fuse block and replacement fuse data.

Phase	Voltage	Drive Model GPD333-	Fuse Part No.	Fuse Rating	Fuse Block Part No.	Mfr
3	230	A0P3N4	ATM25	600V 25A	30323	Gould
3	230	A0P7N4	ATM25	600V 25A	30323	Gould
3	230	A001N4	ATM25	600V 25A	30323	Gould
3	230	A002N4	ATM25	600V 25A	30323	Gould
3	230	A003N4	CR2LS-50	250V 50A	CM-1A	Fuji
3	230	A005N4	CR2LS-50	250V 50A	CM-1A	Fuji
3	460	B0P5N4	ATM15	600V 15A	30323	Gould
3	460	B0P7N4	ATM15	600V 15A	30323	Gould
3	460	B001N4	ATM15	600V 15A	30323	Gould
3	460	B002N4	ATM15	600V 15A	30323	Gould
3	460	B003N4	ATM25	600V 25A	30323	Gould
3	460	B005N4	ATM25	600V 25A	30323	Gould

APPENDIX 1 DYNAMIC BRAKING OPTION

GENERAL. Dynamic braking (DB) enables the motor to be brought to a smooth and rapid stop. This is achieved by dissipating the regenerative energy of the AC motor across the resistive components of the Dynamic Braking option. For further details on dynamic braking, see the option instruction sheet shipped with the dynamic braking components.

The GPD 333 has an integral braking transistor. However, to make use of the Dynamic Braking function requires addition of either a MagneTek Braking Resistor (for 3% duty cycle) or Braking Resistor Unit (for 10% duty cycle). See Table A1-1. In either case, interface to external control circuitry is necessary to ensure that dynamic brake resistor overheating is communicated to the drive as a fault condition.

Table A1-1. GPD 333 DB Components

GPD 333 Drive		MagneTek DB Components			
		Braking Resistor		Braking Resistor Unit	
Voltage	HP(CT)	Part No.	Qty Reqd	Part No.	Qty Reqd
2	1/3	50185531	1	N/A	—
	3/4	50185430	1	5P41-0742	1
3	1	50185430	1	5P41-0742	1
	2	50185431	1	5P41-0743	1
0	3	50185432	1	5P41-0744	1
	5	50185433	1	5P41-0745	1
4	1/2	50185530	1	N/A	—
	3/4	50185530	1	5P41-0752	1
6	1.5	50185530	1	5P41-0752	1
	2	50185531	1	5P41-0753	1
0	3	50185532	1	5P41-0754	1
	5	50185531	2 ⁽¹⁾	5P41-0755	1

⁽¹⁾ The two braking resistors required by this drive are to be wired to drive terminals *in parallel*.

INSTALLATION

This option must be installed by a **TECHNICALLY QUALIFIED INDIVIDUAL** who is familiar with this type of equipment and the hazards involved.

WARNING

HAZARDOUS VOLTAGE CAN CAUSE SEVERE INJURY OR DEATH.

LOCK ALL POWER SOURCES FEEDING THE DRIVE IN THE "OFF " POSITION.

CAUTION

FAILURE TO FOLLOW THESE INSTALLATION STEPS MAY CAUSE EQUIPMENT DAMAGE OR PERSONNEL INJURY.

Preliminary Procedures

1. Disconnect all electrical power to the drive.
2. Remove the GPD 333 access cover.
3. Verify that voltage has been disconnected by using a voltmeter to check for voltage at the incoming power terminals.

Braking Resistor (3% Duty Cycle) Installation

NOTE: The 3% duty cycle Braking Resistor is supplied with 6 inch leads.

1. Mount the Braking Resistor, along with an overload or thermostat, in a suitable metal enclosure.

2. Connect leads from the Braking Resistor to drive terminals, and make connections to external control circuit, as shown in Figure A1-1.
3. Reinstall the GPD 333 access cover.
4. Proceed to "ADJUSTMENTS" on page 61.

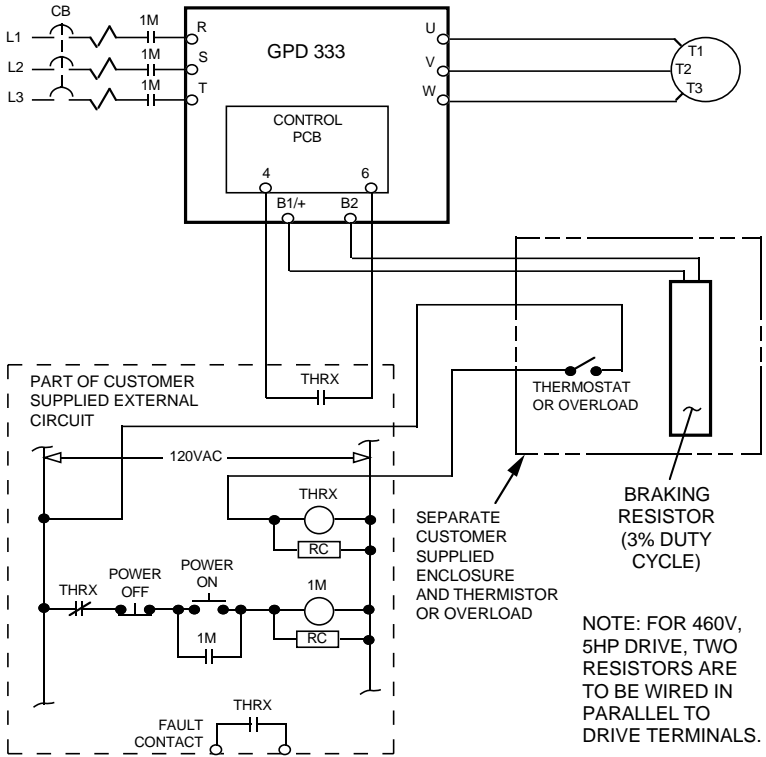

Figure A1-1. Typical Wiring of Braking Resistor (for 3% Duty Cycle) to Drive

Braking Resistor Unit (10% Duty Cycle) Installation

IMPORTANT

Since the Braking Resistor Unit generates heat during the dynamic braking operation, install it in a location away from other equipment which emits heat.

1. Mount the Braking Resistor Unit on a vertical surface, maintaining minimum 1.18 inch (30 mm) clearance on each side and 5.91 inch (150 mm) clearance top and bottom.
2. Open the Braking Resistor Unit terminal box to access its terminal block. Connect the Braking Resistor Unit to the drive and external control circuit according to Table A1-2 and Figure A1-2.

Table A1-2 Wire Sizing For Braking Resistor Unit

Terminals	B, P	1, 2 *
Lead Size (AWG)	12-10	18-14 *
Lead Type	600V ethylene propylene rubber insulated, or equivalent	
Terminal Screw	M4	

* Power leads for the Braking Resistor Unit generate high levels of electrical noise; these signal leads must be grouped separately.

3. Close and secure the cover of the Braking Resistor Resistor Unit terminal box. Reinstall the GPD 333 access cover.
4. Proceed to "ADJUSTMENTS" on page 61.

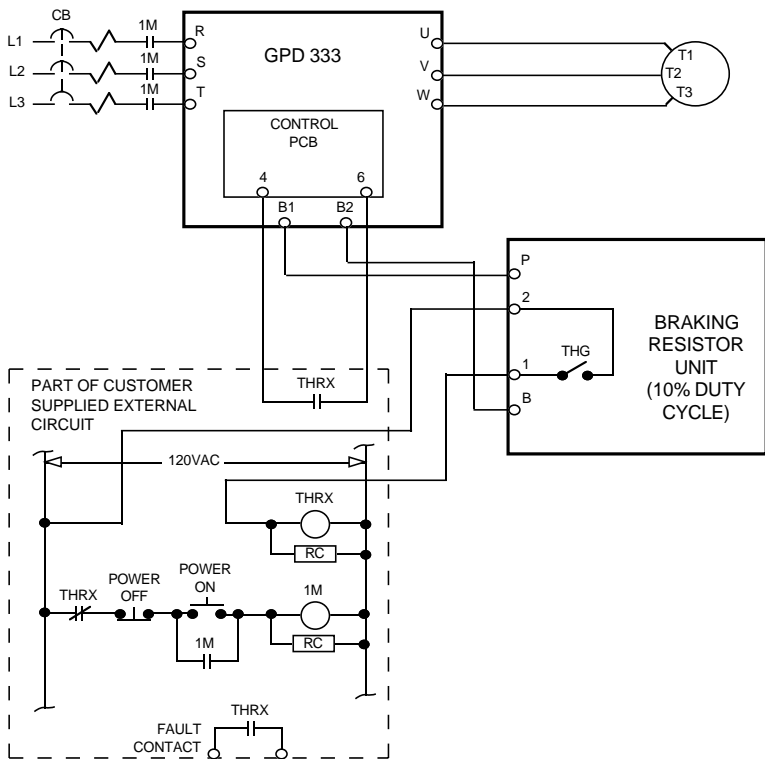

Figure A1-2. Typical Wiring of Braking Resistor Unit (for 10% Duty Cycle) to Drive

ADJUSTMENTS

Program constant **no-20** to **1 X X X**: this disables stall prevention during deceleration.

This page intentionally left blank.

APPENDIX 2 GPD 333 SPARE PARTS

MagneTek does not offer spare parts for the GPD 333. Because of the compact size of the drive and the inherent difficulty of properly installing replacement parts, MagneTek recommends changing out the complete drive unit if troubleshooting determines that it is defective.

A MagneTek authorized repair shop may be able to repair a defective drive, but this would necessitate longer down-time.

When changing out a drive unit, make sure that any of the following separately priced options are transferred to the replacement unit, unless they are already present on the replacement unit:

- Attached to control terminals:
 - 24 Vdc Interface board
 - 115 Vac Interface board
 - Auxiliary Potentiometer Card
- Attached to heat sink:
 - Din Rail Mount
- Mounted on front of drive:
 - Digital Operator (DS039) [Note: This is a standard part of a NEMA 4/12 GPD 333; therefore, DO NOT remove it.]
 - Remote Interface Panel (DS090)
 - Analog Speed Input board (DS091)
 - Any serial communication interface board (NCL/Modbus Plus, DeviceNet, SDS, etc.)

NOTE: If the defective GPD 333 has Modbus RTU interface (a factory installed option), the replacement GPD 333 must also have the interface factory installed.

Be sure to program the replacement drive unit as required for installed options; see their separate instruction sheets, which should already be on hand.

Please send more information on the following MagneTek products:

___ Adjustable Frequency Drives _____ HP
for _____
(Application)

___ Direct Current Drives _____ HP
for _____
(Application)

Name _____

Position / Title _____

Company _____

Address _____

City _____

State _____ ZIP _____

Telephone () _____

TM 4333

Please send a free set of
GPD 333 Troubleshooting Flowcharts

Name _____

Position / Title _____

Company _____

Address _____

City _____

State _____ ZIP _____

Telephone () _____

Drive used on: _____

Purchased from: _____

TM 4333

Ken Cook Co. to print properly
sized preaddressed mailer in
this area.

Ken Cook Co. to print properly
sized preaddressed mailer in
this area.

GPD 333

Data subject to change without notice. GPD and Century are trademarks of MagneTek, Inc..

MagneTek

Drives & Systems

16555 W. Ryerson Road, New Berlin, Wisconsin 53151

(800) 541-0939, (414) 782-0200, FAX (414) 782-1283

