

Technical Tip: How to Connect and Troubleshoot Transducer Feedback

Product(s): iQpump1000 and iQpump Micro Drives

Doc. No. TN.iQp.03

This Technical Tip assists users in applying Yaskawa iQpump1000 and iQpump Micro products to pump systems and provides useful information on:

- running without a transducer
- fixing Fdb-L or Feedback Loss faults/alarms
- proper transducer wiring
- settings for voltage or current transducers
- multiple transducer wiring

What feedback transducers work with iQpump?

Yaskawa's iQpump1000 and iQpump Micro drives utilize transducer feedback to change pump speed to optimize system efficiency and performance.

iQpump drives typically interface with either pressure, flow, and/or temperature transducers; most commonly pressure transducers with a 4-20 mA output.

4-20 mA pressure transducers have a maximum measurement range and the transducer will output 4 mA at zero pressure and proportionally increase to 20 mA at maximum pressure. Proper transducer wiring is key to running the iQpump in "Auto" regulating mode.

Will the iQpump Run Without a Transducer?

The drive will display **Feedback Loss (iQpump1000)** or **Fdb-L (iQpumpMicro)** with a blinking "ALM" indicator as shown in Figure 1, if the drive is powered up without a transducer connected. This is normal operation until transducer wiring to the A2 terminal is complete.

Technical Tip: How to Connect and Troubleshoot Transducer Feedback

Product(s): iQpump1000 and iQpump Micro Drives

Doc. No. TN.iQp.03

Figure 1: iQpump1000 and iQpump Micro Feedback Loss Display

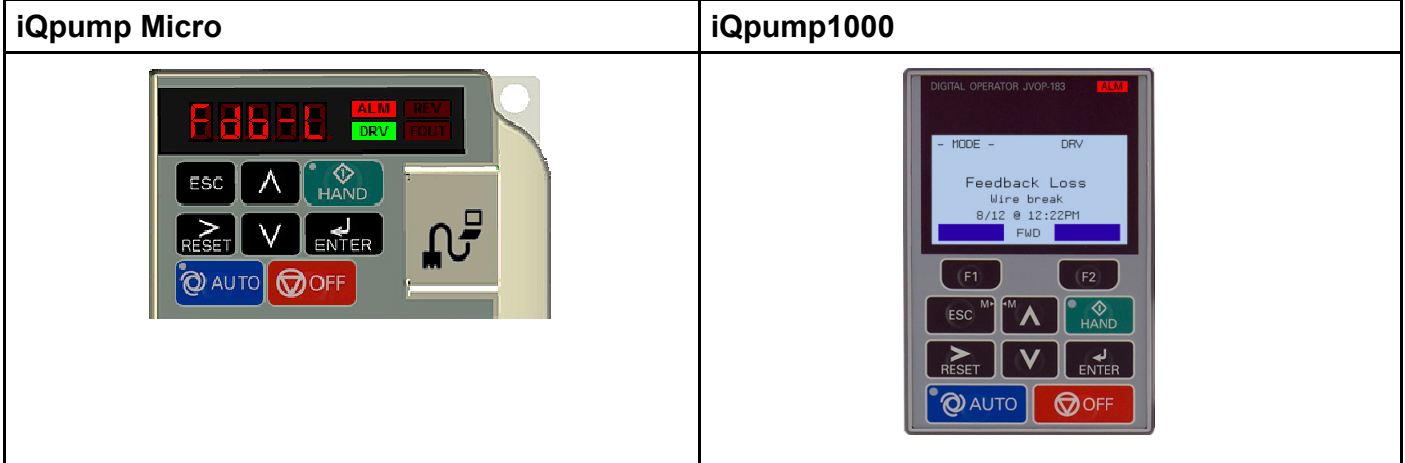

Run in HAND Mode

The iQpump will operate in HAND mode at fixed speed without transducer feedback. HAND mode is useful for setting up the system without transducer feedback or operating the pump with a damaged transducer.

How to Fix Fdb-L or Feedback Loss

Follow these steps to isolate the wiring issue if the iQpump indicates **Fdb-L** or **Feedback Loss**.

1. Verify the transducer connections are properly stripped of insulation and connected for 2-wire or 3-wire according to Figure 2 for iQpump Micro models, and Figure 3 for iQpump1000 models. Not all transducer cables are shielded, in which case the E(G) or FE connections can be ignored.

Technical Tip: How to Connect and Troubleshoot Transducer Feedback

Product(s): iQpump1000 and iQpump Micro Drives

Doc. No. TN.iQp.03

Figure 2: iQpump Micro 2 and 3-Wire Transducer Connections

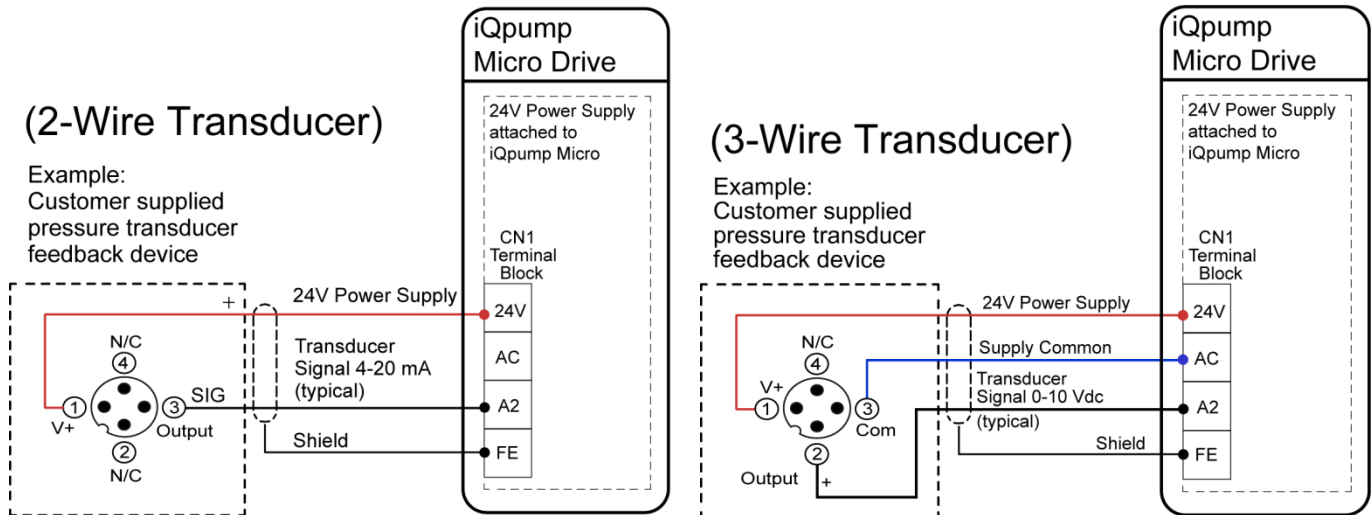
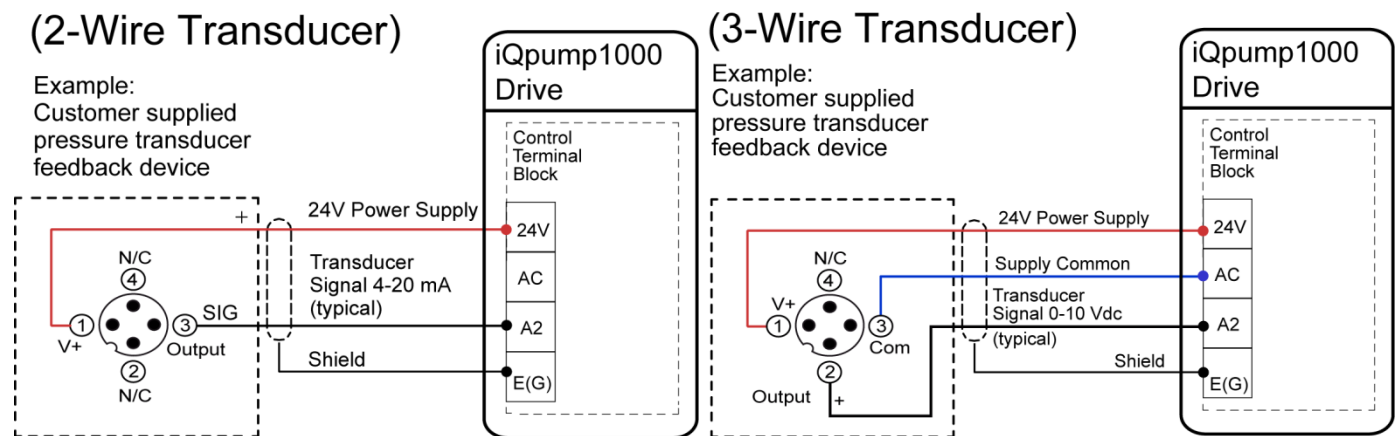

Figure 3: iQpump1000 2 and 3-Wire Transducer Connections



Technical Tip: How to Connect and Troubleshoot Transducer Feedback

Product(s): iQpump1000 and iQpump Micro Drives

Doc. No. TN.iQp.03

External power supply and multi-drive wiring diagrams can be found in section 3.8 of the iQpump1000 Quick Start Guide for alternate wiring topologies.

Note: Steps 2~5 are factory set by default for a 4-20 mA transducer wired to terminal A2

2. **Voltage/Current Selection:** Verify the proper setting of switches and jumpers on each drive:

- a. **iQpump Micro** terminal board DIP Switch S1 should be in the 'I' position for current feedback transducers or 'V' position for voltage feedback transducers (see Figure 4).
- b. **iQpump1000:** Jumper S1 position A2. Jumper S1-A2 should be in the 'I' position for current feedback transducers or 'V' position for voltage feedback transducers (see Figure 4).

Figure 4: Terminal A2 Voltage/Current Selection

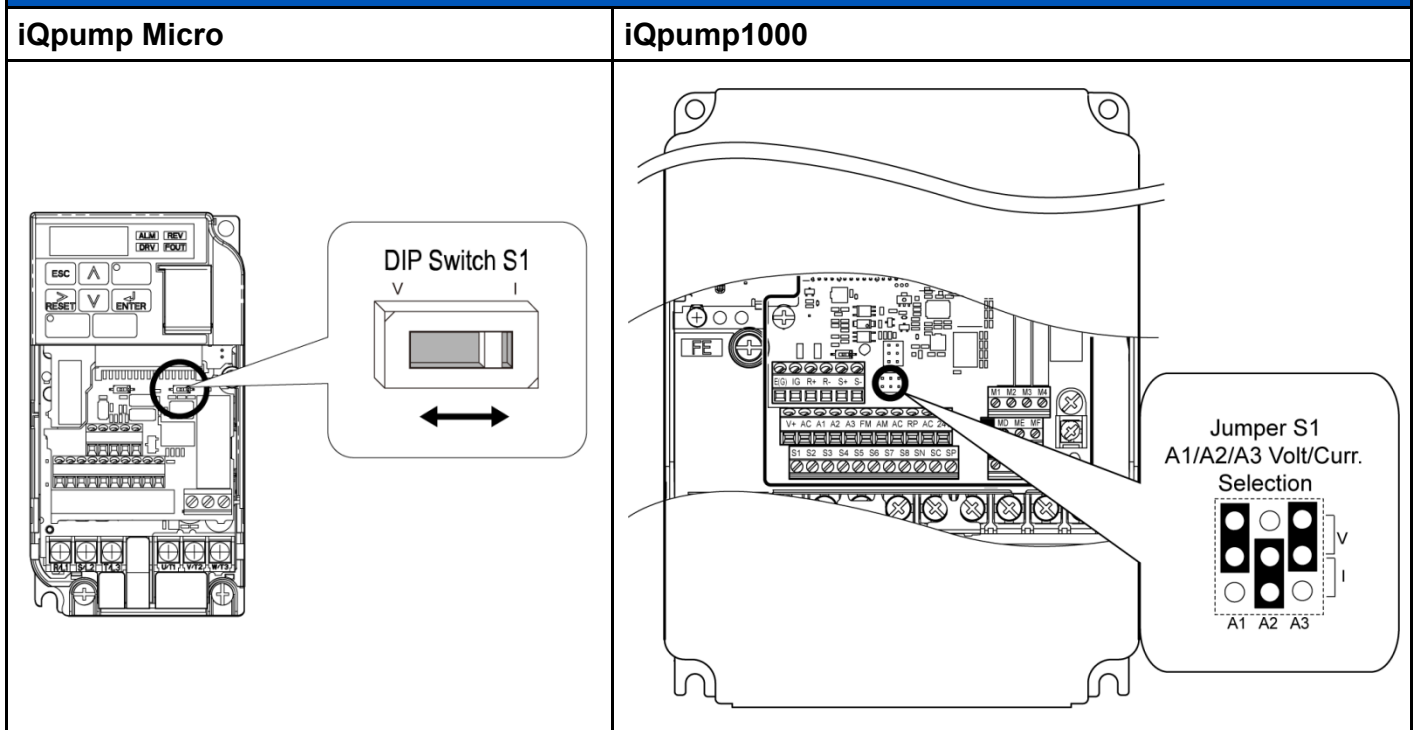

Technical Tip: How to Connect and Troubleshoot Transducer Feedback

Product(s): iQpump1000 and iQpump Micro Drives

Doc. No. TN.iQp.03

- Verify the parameter *H3-09 Terminal A2 Signal Level Selection* is properly set according to the signal type. Typically 2 for current feedback devices or 0 for voltage feedback devices.

No.	Name	Description	Values
H3-09	Terminal A2 Signal Level Selection	0: 0 to 10 V 1: -10 to 10 V 2: 4 to 20 mA 3: 0 to 20 mA	Default: 2 Range: 0 to 3

- Verify the proper Terminal A2 Function Selection (H3-10), typically 'B' for PID Feedback.

If terminal A2 is not chosen as the primary transducer feedback input, *H3-10 Terminal A2 Function Selection* must be disabled and terminal A1 or A3 must be configured for the appropriate settings following steps 1-4.

How to Wire Multiple Transducers or use an External Transducer Power Supply

- External power supply and multi-drive transducer wiring diagrams can be found in:
 - iQpump1000:** Section 3.8 of the iQpump1000 Quick Start Guide TOEPYAIP1W01.

Contact Yaskawa America, Inc. technical support at 800-YASKAWA (927-5292) if you have any other questions regarding the Transducer Feedback Loss feature.

Table of Related Parameters

No.	Name	Description	Values
H3-09	Terminal A2 Signal Level Selection	1: -10 to 10 V 2: 4 to 20 mA 3: 0 to 20 mA Note: Use Jumper S1 to set input terminal A2 for a current or voltage input signal.	Default: 2 Range: 0 to 3
H3-10	Terminal A2 Function Selection	Sets the function of terminal A2.	Default: B Range: 0 to 32