

VARISPEED-686SS5 INSTRUCTION MANUAL

SUPER-ENERGY SAVING VARIABLE SPEED DRIVE (VS-686SS5)

MODEL: CIMR-SSA []

200V CLASS 0.4 to 75kW (1.2 to 110kVA)

400V CLASS 0.4 to 300kW (1.4 to 460kVA)

Upon receipt of the product and prior to initial operation, read these instructions thoroughly, and retain for future reference.

REFERENCE

VARISPEED-686SS5 DESCRIPTIVE MANUAL FOR CONSTANTS (TOE-S686-15.2)



PREFACE

The VS-686SS5 inverter is intended for use only with YASKAWA's SS motor drive. This instruction manual describes installation, maintenance and inspection, troubleshooting, and specifications of the VS-686SS5. Read this instruction manual thoroughly before operation.

YASKAWA ELECTRIC CORPORATION

General Precautions
<ul style="list-style-type: none">• Some drawings in this manual are shown with the protective cover or shields removed, in order to describe detail with more clarity. Make sure all covers and shields are replaced before operating this product.• This manual may be modified when necessary because of improvement of the product, modification, or changes in specifications. Such modifications are denoted by a revised manual No.• To order a copy of this manual, if your copy has been damaged or lost, contact your YASKAWA representative.• YASKAWA is not responsible for any modification of the product made by the user, since that will void your guarantee.

NOTES FOR SAFE OPERATION

Read this instruction manual thoroughly before installation, operation, maintenance or inspection of the VS-686SS5. In this manual, NOTES FOR SAFE OPERATION are classified as “WARNING” or “CAUTION.”



Indicates a potentially hazardous situation which, if not avoided, could result in death or serious injury to personnel.



Indicates a potentially hazardous situation which, if not avoided, may result in minor or moderate injury to personnel and damage to equipment. It may also be used to alert against unsafe practices.

Even items described in  CAUTION may result in a vital accident in some situations. In either case, follow these important notes.

 : These are steps to be taken to insure proper operation.

NOTES ON USE

**WARNING**

The SS5 motor is a synchronous motor equipped with a built-in, high performance magnet as a rotor. The SS5 motor terminals continue to produce high voltage whenever the motor is rotating even if inverter power is OFF. Observe the following when handling the inverter.

- Make sure the motor is stopped when carrying out maintenance, inspection or wiring.
- Connect a low-voltage manual starter to the inverter output side when the motor is rotated by the load even if the inverter power is OFF.

**CAUTION**

- If using a motor with a PG, be sure to confirm the safety and adjust the PG zero-pulse before starting any operation.

Failure to observe this caution may cause the torque to be insufficient, which may result in the following motor malfunctions:

- The motor is pulled in the direction of the load.
- The motor rotates in reverse.
- The motor does not rotate.
- The motor suddenly accelerates.

- Before starting operation, be sure to set the motor constants according to the motor nameplate values.

Failure to observe this caution may cause torque insufficiency, which result in motor malfunctions:

- The motor is pulled in the direction of the load.
- The motor rotates in reverse direction.
- The motor does not rotate.
- The motor is suddenly accelerated.

RECEIVING

**CAUTION**

(Ref. page)

- Do not install or operate any inverter which is damaged or has missing parts.

Failure to observe this caution may result in personal injury or equipment damage. 14

INSTALLATION



CAUTION

(Ref. page)

- Lift the cabinet by the base. When moving the unit, never lift by the front cover.
Otherwise, the main unit may be dropped causing damage to the unit. 16
- Mount the inverter on nonflammable material (i.e. metal).
Failure to observe this caution can result in a fire. 16
- When mounting units in an enclosure, install a fan or other cooling device to keep the intake air temperature below 45°C.
Overheating may cause a fire or damage to the unit. 16

WIRING



WARNING

(Ref. page)

- Only commence wiring after verifying that the power supply is turned OFF.
Failure to observe this warning can result in an electric shock or a fire. 20
- Wiring should be performed only by qualified personnel.
Failure to observe this warning can result in an electric shock or a fire. 20
- When wiring the emergency stop circuit, check the wiring thoroughly before operation.
Failure to observe this warning can result in personal injury. 20
- Make sure to ground the ground terminal .
(Ground resistance
200V class: 100Ω or less, 400V class: 10Ω or less)
Failure to observe this warning can result in an electric shock or a fire. 24



CAUTION

(Ref. page)

- Do not connect the other type of motor (i.e. induction motor). The VS-686SS5 inverter is exclusive-use for SS5 motor drive.
Failure to observe this caution can result in inverter damage. 20
- Verify that the inverter rated voltage coincides with the AC power supply voltage.
Failure to observe this caution can result in personal injury or a fire. 20
- Do not perform a withstand voltage test of the inverter.
It may cause semi-conductor elements to be damaged. 20
- To connect a braking resistor, braking resistor unit or braking unit, follow the procedures described in APPENDIX 3.
Improper connection may cause a fire. 20
- Tighten terminal screws to the specified tightening torque.
Failure to observe this caution can result in a fire. 20
- Never connect the AC main circuit power supply to output terminals U, V and W.
The inverter will be damaged and invalidate the guarantee. 24
- (Standard connection)
Be sure to connect the motor leads to the correct output terminals:
Motor lead U to output terminal U,
Motor lead V to output terminal V, and
Motor lead W to output terminal W.
Failure to observe this caution may cause the motor to run unusual way such as in reverse. 24
- With the standard connection for the output terminals, the motor rotates counterclockwise as viewed from the load side in a forward operation.
To rotate the motor clockwise in a forward operation, connect the output terminals as referred in Appendix 6. 24

OPERATION



WARNING

(Ref. page)

- Only turn ON the input power supply after replacing the front cover. Do not remove the cover while current is flowing.
Failure to observe this warning can result in an electric shock. 38
- When the retry function (L5-02) is selected, do not approach the inverter or the load, since it may restart suddenly after being stopped.
(Construct machine system, so as to assure safety for personnel, even if the inverter should restart.)
Failure to observe this warning can result in personal injury. 38
- Since the stop button can be disabled by a function setting, install a separate emergency stop switch.
Failure to observe this warning can result in personal injury. 38
- If an alarm is reset with the operation signal ON, the inverter restarts automatically. Only reset the alarm after verifying that the operation signal is OFF.
Failure to observe this warning can result in personal injury. 38
- When adjusting PG zero-pulse, disconnect the motor from the machine.
The motor rotates automatically during adjustment. 49
- When PG zero-pulse adjustment is completed, "End" is displayed on the digital operator. Do not touch it until it has come to a complete stop.
The motor starts and stops repeatedly when adjustments are made. 49



CAUTION

(Ref. page)

- Never touch the heatsink or discharging resistor since the temperature is very high.
Failure to observe this caution can result in harmful burns to the body. 38
- Since it is easy to change operation speed from low to high speed, verify the safe working range of the motor and machine before operation.
Failure to observe this caution can result in personal injury and machine damage. . . 38
- Install a holding brake separately if necessary.
Always construct the external sequence to confirm that the holding brake is activated in the event of an emergency, a power failure, or an abnormality in the inverter occurring.
Failure to observe this caution can result in personal injury. 38
- If using with an elevator, take safety measures on the machine's side to prevent the elevator from dropping.
Failure to observe this caution may result in personal injury. 38
- Do not change signals during operation.
The machine or the inverter may be damaged. 38



CAUTION

(Ref. page)

- All the constants of the inverter have been preset at the factory. Do not change the settings unnecessarily.
The inverter may be damaged. For supply voltage, follow Par. 4.2. 38
- Be sure to set the motor constants in accordance with the values listed on the motor nameplate values. 38
Failure to observe this caution may cause the torque to be insufficient, which may result in the following motor malfunctions:
 - The motor is pulled in the direction of the load.
 - The motor rotates in reverse.
 - The motor does not rotate.
 - The motor suddenly accelerates.
- Be sure to set the motor constants before the initial operation and after replacement of the motor. Reconfirm the motor constants after they have been set.
Failure to observe this caution may result in motor malfunctions such as sudden acceleration. 44
- In the following cases when under flux vector control, be sure to adjust the PG zero-pulse as described in 4.3 (3) (e) PG Zero-pulse Adjustment: . . . 44
 - Before initial operation.
 - After replacing the motor.
 - After replacing the PG.
- Verify that digital operator STOP LED is ON before checking motor speed detection. 48
- Verify that nothing is caught on the shaft or coupling. 48
- If the constant b1-06 is set to 1 and the run command is ON, the motor will start immediately if the following operations are done. Confirm the safety if such operation is required.
 - The operation mode is switched from LOCAL to REMOTE.
 - The power supply is turned ON.
 Failure to observe this caution may result in personal injury. 71
- Confirm safety. 49
 - Is the motor disconnected from the machine?
 - Is the lock key disconnected from the machine?
 - Are there any persons or objects near the motor shaft?
 - Has the motor come to a complete stop?

MAINTENANCE AND INSPECTION



WARNING

(Ref. page)

- Never touch high-voltage terminals in the inverter.
Failure to observe this warning can result in an electric shock. 65
- Replace all protective covers before powering up the inverter. To remove the cover, make sure to shut OFF the molded-case circuit breaker.
Failure to observe this warning can result in an electric shock. 65
- Perform maintenance or inspection only after verifying that the CHARGE LED goes OFF, after the main circuit power supply is turned OFF.
The capacitors are still charged and can be dangerous. 65
- Only authorized personnel should be permitted to perform maintenance, inspections or parts replacement.
[Remove all metal objects (watches, bracelets, etc.) before operation.]
(Use tools which are insulated against electrical shock.)
Failure to observe this warning can result in an electric shock. 65



CAUTION

(Ref. page)

- The control PC board employs CMOS ICs. Do not touch the CMOS elements.
They are easily damaged by static electricity. 65
- Do not connect or disconnect wires or connectors while power is applied to the circuit.
Failure to observe this caution can result in personal injury. 65

OTHERS



WARNING

- Never modify the product.
Failure to observe this warning can result in an electrical shock or personal injury and will invalidate the guarantee.

WARNING LABEL

A warning label is displayed on the front cover of the inverter, as shown below. Follow these instructions when handling the inverter.

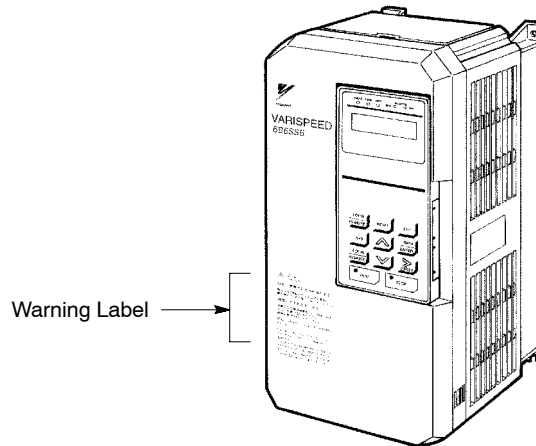

Model CIMR-SSA23P7

WarningLabel

	<p>危険 WARNING</p>
<p>けが、感電のおそれがあります。</p> <ul style="list-style-type: none"> ・ 据え付け、運転の前には必ず取扱説明書を読んで、その指示に従ってください。 <p>感電のおそれがあります。</p> <ul style="list-style-type: none"> ・ 通電中及び電源遮断後1分以内は、表面カバーを開けないでください。 ・ 確実に接地を行ってください。 ・ 保守・点検、配線を行う場合は、必ずモータが停止していることを確認し、U, V, W 各端子間電圧が [OV] である事を確認してから作業を行ってください。 <p>May cause injury or electric shock.</p> <ul style="list-style-type: none"> ・ Please follow the instructions in the manual before installation or operation. ・ Disconnect all power before opening front cover of unit. Wait 1 minute until DC Bus capacitors discharge. ・ Use proper grounding techniques. ・ Make sure that the motor has stopped and voltage between terminals U-V, U-W, and V-W is "0 volt" before maintenance, inspection, or wiring. 	

CONTENTS

NOTES FOR SAFE OPERATION	4
1 RECEIVING	14
1.1 INSPECTION CHECKPOINTS	14
1.2 IDENTIFYING THE PARTS	15
2 INSTALLATION	16
2.1 REMOVING AND REPLACING THE DIGITAL OPERATOR	16
2.2 REMOVING AND REPLACING THE FRONT COVER	17
2.3 CHOOSING A LOCATION TO MOUNT THE INVERTER	18
2.4 CLEARANCES	19
3 WIRING	20
3.1 CONNECTION WITH PERIPHERAL UNITS	21
3.2 CONNECTION DIAGRAM	22
3.3 WIRING THE MAIN CIRCUIT	24
3.4 WIRING THE CONTROL CIRCUIT	36
3.5 WIRING INSPECTION	37
4 OPERATION	38
4.1 TEST RUN CHECKPOINTS	39
4.2 SETTING THE LINE VOLTAGE USING JUMPER (FOR 400V CLASS 18.5kW AND ABOVE)	39
4.3 TEST RUN	40
5 SETTING OPERATION CONDITIONS	56
5.1 DIGITAL OPERATOR KEY DESCRIPTION	56
5.2 DIGITAL OPERATOR MODE SELECTION	57
5.3 DRIVE MODE	58
5.4 INITIALIZE MODE	61
5.5 PROGRAM MODE	63
5.6 MODIFIED CONSTANTS MODE	64
6 MAINTENANCE AND INSPECTION	65
6.1 PERIODIC INSPECTION	66
6.2 PARTS REPLACEMENT SCHEDULE (GUIDELINES)	66
7 TROUBLESHOOTING	67
7.1 FAULT DIAGNOSIS AND CORRECTIVE ACTIONS	67
7.2 MOTOR FAULTS AND CORRECTIVE ACTIONS	71
APPENDIX 1 SPECIFICATIONS	72
APPENDIX 2 DIMENSIONS (mm)	74
200 V/400 V Class Inverters of 15 kW and Lower	74
200 V/400 V Class Inverters of 18.5 kW and Higher	74
Mounting Dimensions for 400 V Class Inverters of 220 to 300 kW	74
APPENDIX 3 TYPICAL CONNECTION DIAGRAM	76
3.1 BRAKING RESISTOR UNIT	76
3.2 BRAKING UNIT AND BRAKING RESISTOR UNIT	77
3.3 THREE BRAKING UNITS IN PARALLEL	80
3.4 WITH CONTACT OUTPUT, OPEN COLLECTOR OUTPUT	83
APPENDIX 4 CONSTANTS LIST	84

APPENDIX 5 ERROR PROCESSING IN PG ZERO-PULSE ADJUSTMENT	90
APPENDIX 6 ROTATION DIRECTION OF MOTOR	92
APPENDIX 7 ZDEV CAUSES AND CORRECTIVE ACTIONS LIST	93
Revision History	

1 RECEIVING

⚠ CAUTION
<ul style="list-style-type: none"> Do not install or operate any inverter which is damaged or has missing parts. Failure to observe this caution may result in personal injury or equipment damage.

This chapter describes how to verify the inverter after delivery to the user.

1.1 INSPECTION CHECKPOINTS

(1) Receiving Checkpoints

Table 1 Checkpoints

Checkpoints	Description
Does the inverter model number correspond with the purchase order?	Check the model number on the nameplate on the side of the VS-686SS5.
Are any parts damaged?	Visually check the exterior and verify that there was no damage during transport.
Is hardware properly seated and securely tightened?	Remove inverter front cover. Check all visible hardware with appropriate tools.
Was an instruction manual received?	VS-686SS5 instruction manual (No.: TOE-S686-15)

If any of the above checkpoints are not satisfactory, contact your YASKAWA representative.

(2) Checking the Nameplate Data

(a) Nameplate Data

Example of Japan domestic standard model CIMR-SSA2018 (200VAC 18.5kW)

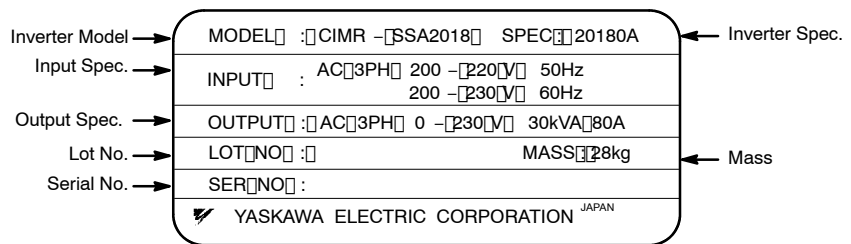

(b) Model Designation

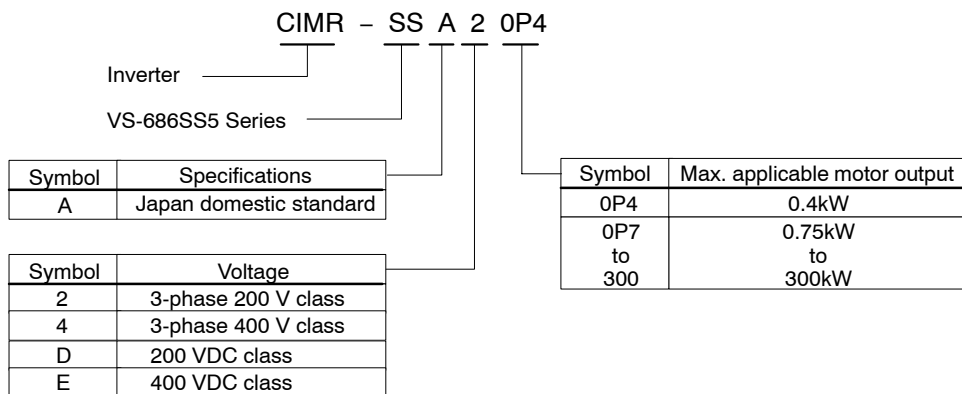

(c) Specification Designation

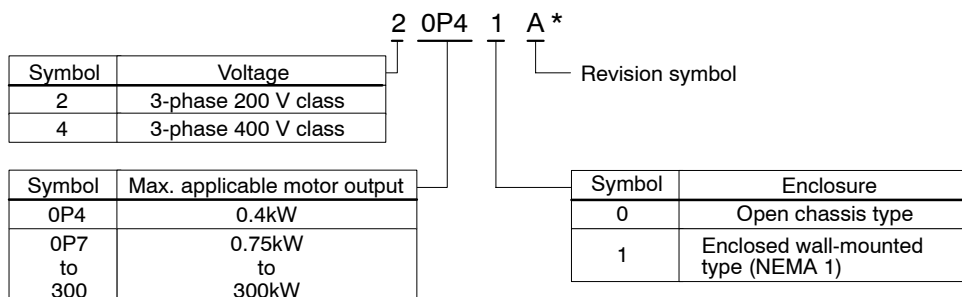

* For special specifications, a spec. sheet No. appears on the nameplate.

1.2 IDENTIFYING THE PARTS

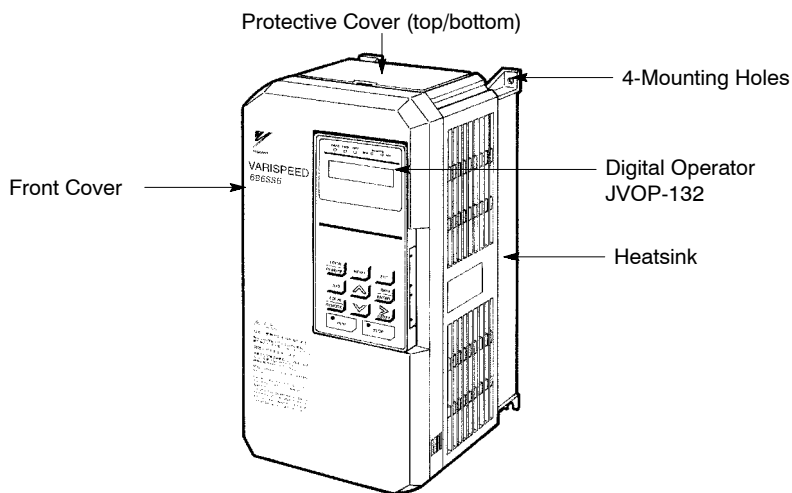

Fig. 1 Configuration of VS-686SS5 (Model CIMR-SSA20P4)

2 INSTALLATION



CAUTION

- Lift the cabinet by the base. When moving the unit, never lift by the front cover. Otherwise, the main unit may be dropped causing damage to the unit.
- Mount the inverter on nonflammable material (i.e. metal). Failure to observe this caution can result in a fire.
- When mounting units in an enclosure, install a fan or other cooling device to keep the intake air temperature below 45°C. Overheating may cause a fire or damage to the unit.

This chapter describes the configuration, location and space when mounting the VS-686SS5.

2.1 REMOVING AND REPLACING THE DIGITAL OPERATOR

Remove and replace the digital operator as follows.

(1) Removing the Digital Operator

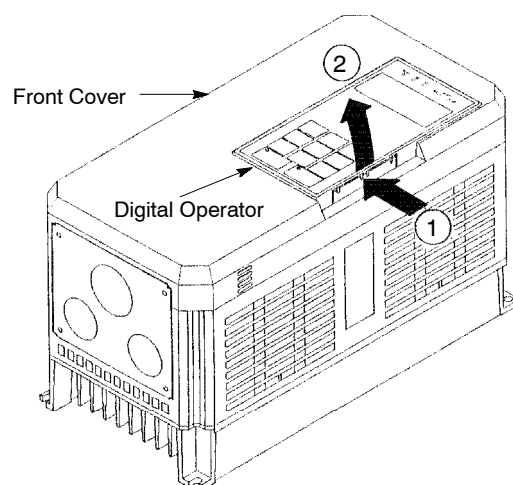

Push the digital operator lever in the direction shown by arrow 1 and lift the digital operator in the direction shown by arrow 2 to remove the digital operator from the front cover.

Fig. 2 Removing the Digital Operator

(2) Replacing the Digital Operator

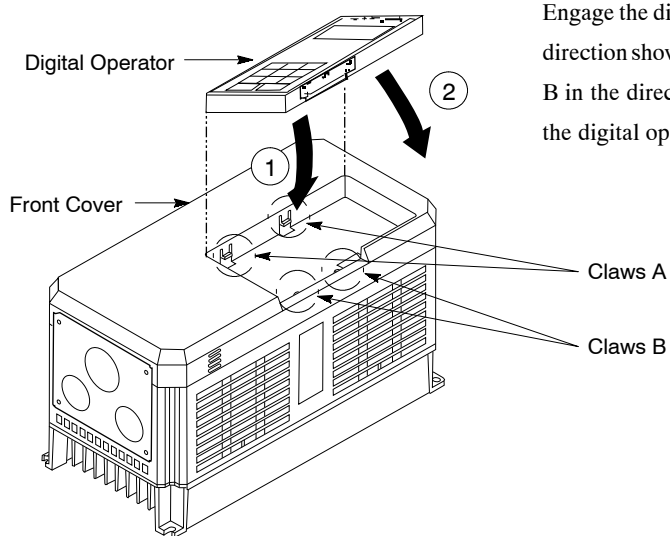

Engage the digital operator on claws A in the direction shown by arrow 1 and then on claws B in the direction shown by arrow 2 to lock the digital operator.

Fig. 3 Replacing the Digital Operator

NOTE

Never fit the digital operator in any other direction or by any other method. The digital operator will not be connected to the inverter.

2.2 REMOVING AND REPLACING THE FRONT COVER

To remove the front cover, first move the digital operator in the direction shown by arrow 1. (See Par. 2.1.) Then squeeze the cover in the direction shown by arrows 2 on both sides and lift in the direction shown by arrow 3.

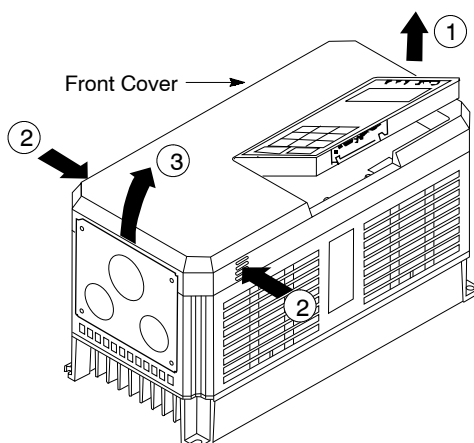

Fig. 4 Removing and Replacing the Front Cover

**NOTE**

Do not replace the front cover with the digital operator connected. The digital operator will not be connected to the inverter. Replace the front cover first and then install the digital operator on the cover. See Par. 2.1 for replacing the digital operator.

2.3 CHOOSING A LOCATION TO MOUNT THE INVERTER

To ensure proper performance and long operating life, follow the recommendations below when choosing a location for installing the VS-686SS5. Make sure the inverter is protected from the following conditions:

- Extreme cold and heat.
Use only within ambient temperature range: -10°C to $+40^{\circ}\text{C}$
- Rain, moisture. (For enclosed wall-mounted type)
- Oil sprays, splashes
- Salt spray.
- Direct sunlight. (Avoid using outdoors.)
- Corrosive gases or liquids.
- Dust or metallic particles in the air. (For enclosed wall-mounted type)
- Physical shock, vibration.
- Magnetic noise. (Example: welding machines, power devices, etc.)
- High humidity.
- Radioactive materials.
- Combustibles: thinners, solvents, etc.

2.4 CLEARANCES

Install the VS-686SS5 vertically and allow sufficient clearances for effective cooling as shown in Fig. 5.

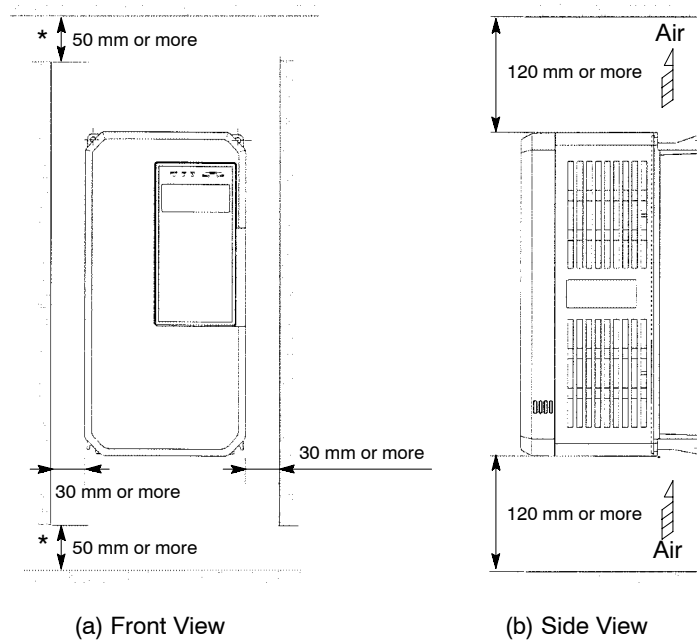

Fig. 5 Clearances

NOTE

1. The clearances required at top/bottom and both sides are common in open chassis type (IP00) and enclosed wall-mounted type (IP20).
2. Remove the top and bottom covers to use the open chassis type of 15kW or less.
3. When installing the models of 30kW or more equipped with eyebolts, extra spacing will be required on either side. For detailed dimensions, contact your YASKAWA representative.
4. For the external dimensions and mounting dimensions, refer to APPENDIX 2 "DIMENSIONS."
5. Allowable intake air temperature to the inverter:

Open chassis type	:	-10°C to +45°C
Enclosed wall-mounted type	:	-10°C to +40°C
6. Ensure sufficient space for the sections at the upper and lower parts marked with * in order to permit the flow of intake/exhaust air to/from the inverter.

3 WIRING



WARNING

- Only commence wiring after verifying that the power supply is turned OFF.
Failure to observe this warning can result in an electric shock or a fire.
- Wiring should be performed only by qualified personnel.
Failure to observe this warning can result in an electric shock or a fire.
- When wiring the emergency stop circuit, check the wiring thoroughly before operation.
Failure to observe this warning can result in personal injury.



CAUTION

- Do not connect the other type of motor (i.e. induction motor). The VS-686SS5 inverter is exclusive-use for SS5 motor drive.
Failure to observe this caution can result in inverter damage.
- Verify that the inverter rated voltage coincides with the AC power supply voltage.
Failure to observe this caution can result in personal injury or a fire.
- Do not perform a withstand voltage test of the inverter.
It may cause semi-conductor elements to be damaged.
- To connect a braking resistor, braking resistor unit or braking unit, follow the procedures described in APPENDIX 3.
Improper connection may cause a fire.
- Tighten terminal screws to the specified tightening torque.
Failure to observe this caution can result in a fire.

This chapter describes the main circuit wiring and the control circuit wiring of the VS-686SS5.

3.1 CONNECTION WITH PERIPHERAL UNITS

The following shows standard connection of the VS-686SS5 with peripheral units.

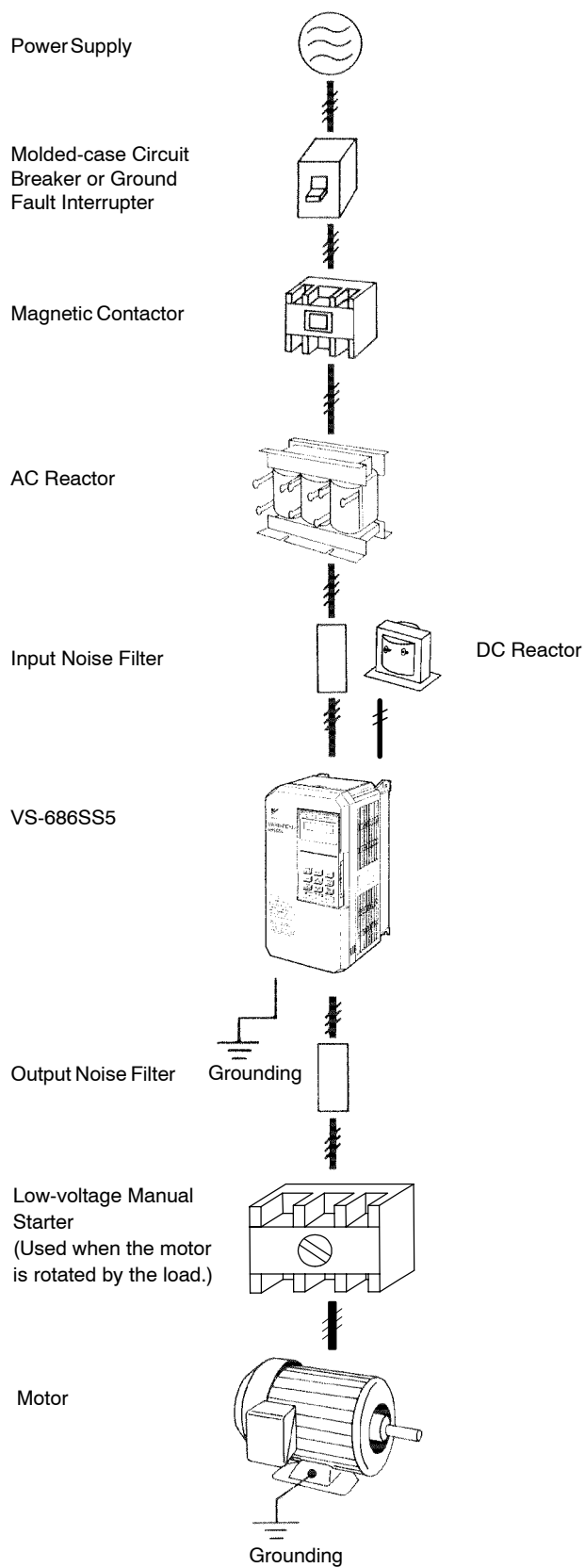

Fig. 6 Connection with Peripheral Units

3.2 CONNECTION DIAGRAM

Below is a connection diagram of the main circuit and control circuit. The example shows the models CIMR-SSA2018 to -SSA2075 (200V class 18.5 to 75kW). Using the digital operator, the motor can be operated by wiring the main circuit only.

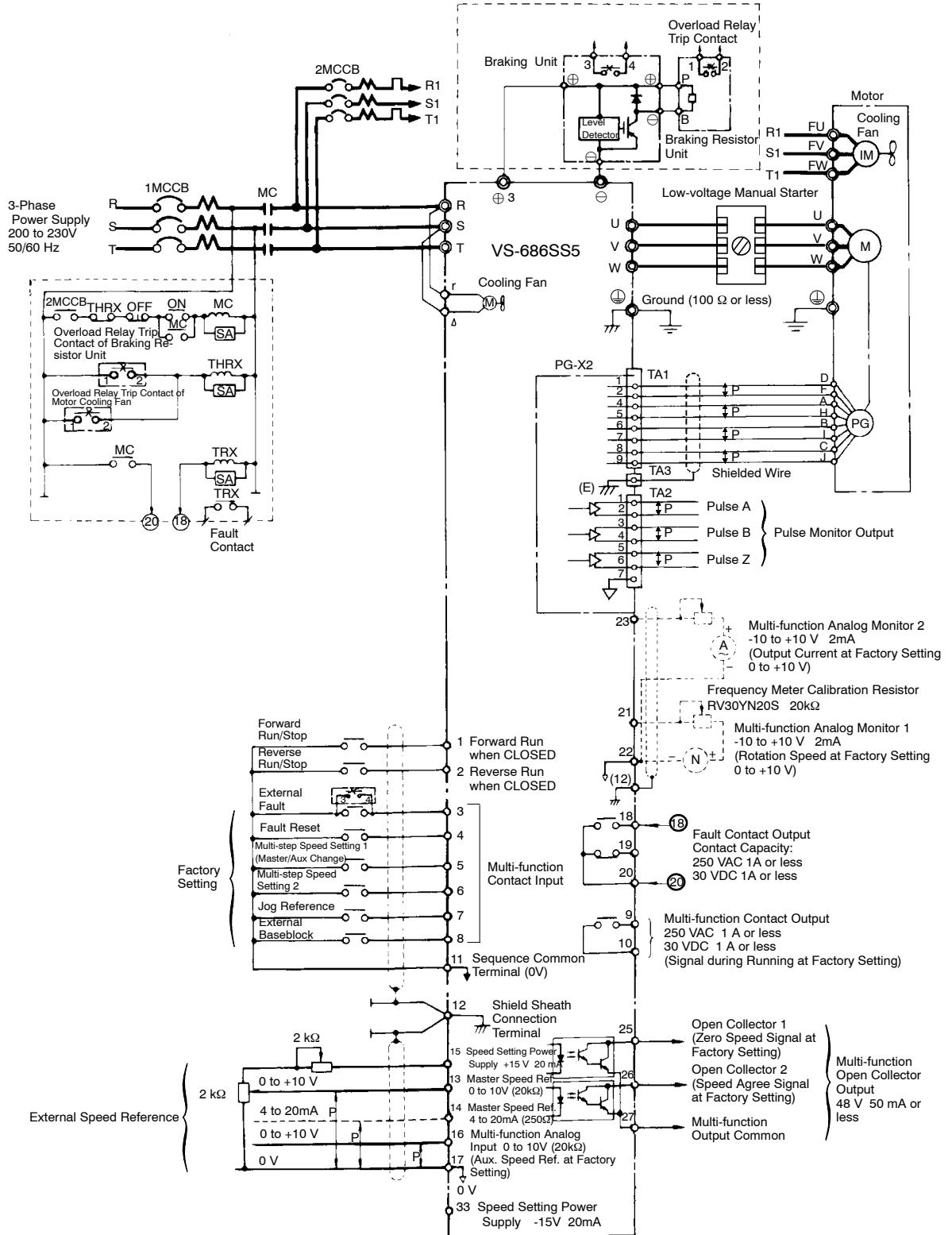



Fig. 7 Connection Diagram

NOTE

Layout of control circuit terminals

11	12(G)	13	14	15	16	17	25	26	27	33	18	19	20
1	2	3	4	5	6	7	8	21	22	23	9	10	

NOTE

-  indicates shielded wires and  indicates twisted-pair shielded wires.
- Either control circuit terminal 13 or 14 can be used. (For simultaneous inputs, the two signals are added internally.)
- Control circuit terminal 15/33 of +15 V/-15 V has a maximum output current capacity of 20 mA.
- Multi-function analog output should be used for monitoring meters (e.g. output frequency meter) and should not be used for feedback control system. Use analog monitor cards (Model AO-12) for the control system, for a more accurate signal.
- When using a braking resistor unit, set the constant L3-01 to "0" (overvoltage prevention level is "disabled"). If it is not changed, the motor may not stop within the set decel time.
- When using model ERF braking resistor (inverter-mounted type), set the constant L8-01 to "01" (braking resistor protection selection to "enabled"). If it is not changed, the braking resistor cannot be protected.
- When installing a DC reactor (optional for models of 15kW or below), remove the short-circuit bar between ⊕1 and ⊕2 terminals and connect a DC reactor with the terminals.
- The models of 200V 30 to 75kW or 400V 55 to 160kW cannot be connected with DC power supply.
- Once external baseblock signal is turned ON, do not release until a motor stops.

3.3 WIRING THE MAIN CIRCUIT



WARNING

- Make sure to ground the ground terminal \oplus .
(Ground resistance 200V class: 100 Ω or less, 400V class: 10 Ω or less)
Failure to observe this warning can result in an electric shock or a fire.



CAUTION

- Never connect the AC main circuit power supply to output terminals U, V and W.
The inverter will be damaged and invalidate the guarantee.
- (Standard connection)
Be sure to connect the motor leads to the correct output terminals:
Motor lead U to output terminal U,
Motor lead V to output terminal V, and
Motor lead W to output terminal W.
Failure to observe this caution may cause the motor to run unusual way such as in reverse.
- With the standard connection for the output terminals, the motor rotates counterclockwise as viewed from the load side in a forward operation. To rotate the motor clockwise in a forward operation, connect the output terminals as referred in Appendix 6.

(1) Wiring Precautions for Main Circuit Input

(a) Installation of Molded-case Circuit Breaker (MCCB)

Make sure to connect MCCBs or fuses between the AC main circuit power supply and VS-686SS5 input terminals R, S and T to protect wiring.

(b) Installation of Ground Fault Interrupter

When connecting a ground fault interrupter to input terminals R, S and T, select one that is not affected by high frequency.

Examples: NV series by Mitsubishi Electric Co., Ltd. (manufactured in or after 1988),
EG, SG series by Fuji Electric Co., Ltd. (manufactured in or after 1984)

(c) Installation of Magnetic Contactor

Inverter can be used without a magnetic contactor (MC) installed at the power supply side. When the main circuit power supply is shut OFF in the sequence, a magnetic contactor (MC) can be used instead of a molded-case circuit breaker (MCCB). However, when a magnetic contactor is switched OFF at the primary side, regenerative braking does not function and the motor coasts to a stop.

- The load cannot be operated/stopped by opening/closing the magnetic contactor at the power supply side.
- When using a braking resistor unit, use a sequencer to break power supply side on over-load relay trip contact. If the inverter malfunctions, the braking resistor unit may be burned out.

(d) Terminal Block Connection Sequence

Input power supply phases can be connected to any terminal regardless of the order of R, S and T on the terminal block.

(e) Installation of Reactor

When connecting an inverter (200V/400V 15kW or less) to a large capacity power supply transformer (600kVA or more), or when switching a phase advancing capacitor, excessive peak current flows in the input power supply circuit, which may damage the converter section. In such cases, install a DC reactor (optional) between inverter $\oplus 1$ and $\oplus 2$ terminals or an AC reactor (optional) on the input side. Installation of a reactor is effective for improvement of power factor on the power supply side.

(f) Installation of Surge Suppressor

For inductive loads (magnetic contactors, magnetic relays, magnetic valves, solenoids, magnetic brakes, etc.) connected near the inverter, use a surge suppressor simultaneously.

(g) Prohibition of Installation of Phase Advancing Capacitor

If a phase advancing capacitor or surge suppressor is connected in order to improve the power factor, it may become overheated and damaged by inverter high harmonic components. Also, the inverter may malfunction because of overcurrent.

(h) Using Input Noise Filters

Noise filters can reduce a higher harmonics noise leaking from the drive unit to the power line.

- Example 1

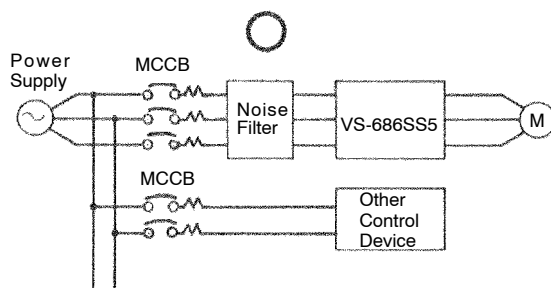

Use an exclusive noise filter specified for the inverter.

Fig. 8 Using Input Noise Filter (Example 1)

- Example 2

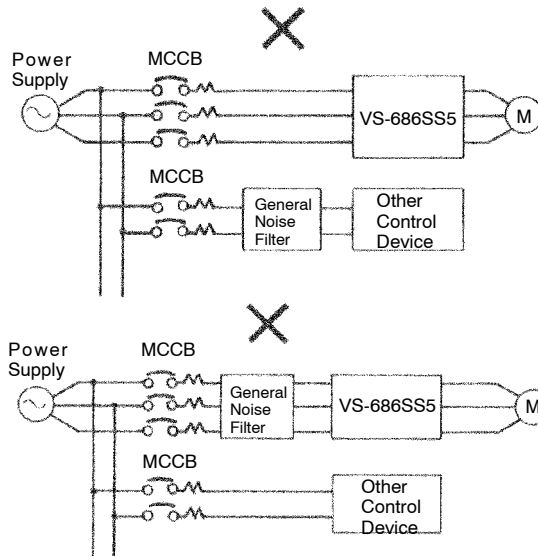

A general-purpose noise filter will not be effective.

Fig. 9 Using Input Noise Filter (Example 2)

- Example 3

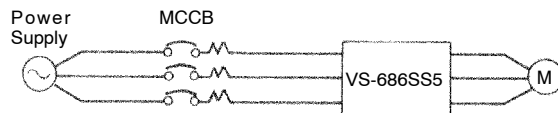

When one inverter is installed on one power line, a noise filter is not required.

Fig. 10 Using Input Noise Filter (Example 3)

- Example 4

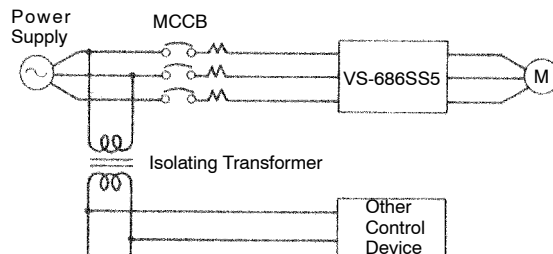

By installing an isolating transformer on the power side of another control device, the same result as with installing a noise filter is achieved.

Fig. 11 Using Input Noise Filter (Example 4)

(2) Wiring Precautions for Main Circuit Output

(a) Connection of Terminal Block and Load

Connect output terminals U, V and W to motor lead wires U, V and W. For standard connections, be sure to connect the motor leads to the correct output terminals: motor lead U to output terminal U, motor lead V to output terminal V, and motor lead W to output terminal W.

With the standard connection for the output terminals, the motor rotates counterclockwise as viewed from the load side in a forward operation. To rotate the motor clockwise in a forward operation, connect the output terminals as referred in Appendix 6.

(b) Strict Prohibition of Connection of Input Power Supply to Output Terminals

Never connect the input power supply to output terminals U, V and W.

(c) Installation of Low-voltage Manual Starter

Make sure to connect a low-voltage manual starter to the inverter output side when the motor is rotated by the load even if the inverter power supply is OFF. Turn OFF the starter before performing maintenance/inspection or wiring.

Example: LB series of AICUT manufactured by Aisei

(d) Strict Prohibition of Short Circuiting or Grounding of Output Circuit

Never touch the output circuit directly or put the output line in contact with the inverter case. Otherwise, it may cause an electric shock or grounding. In addition, never short circuit the output line.

(e) Prohibition of Connection of Phase Advancing Capacitor or LC/RC Line Filter

Never connect a phase advancing capacitor or LC/RC line filter to the output circuit.

(f) Avoidance of Installation of Magnetic Starter

Do not connect a magnetic starter or magnetic contactor to the output circuit. If the load is connected while the inverter is running, the inverter overcurrent protective circuit operates because of inrush current.

(g) Installation of Thermal Overload Relay

An electronic overload protective function is incorporated into the inverter. When using a thermal overload relay, set inverter constant L1-01 to 0 (motor protection selection: disabled).

(h) Using Output Noise Filters

By installing a noise filter on the output side of the inverter, radio frequency interference (RFI) and inductive noise are reduced.

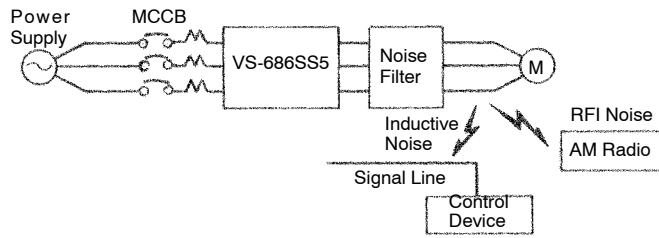

Fig. 12 Using Output Noise Filter

Inductive noise: Noise coming on the signal line due to electromagnetic inductance can cause malfunctioning of a control device.

RFI noise: Higher harmonics waves from the inverter or cable can interfere with radio receiver.

(i) Countermeasures Against Inductive Noise

As described previously, a noise filter can be used to prevent inductive noise from generated on the output side. Alternatively, cables can be routed through a grounded metal pipe to prevent inductive noise. Keeping the metal pipe at least 30 cm away from the signal line considerably reduces inductive noise.

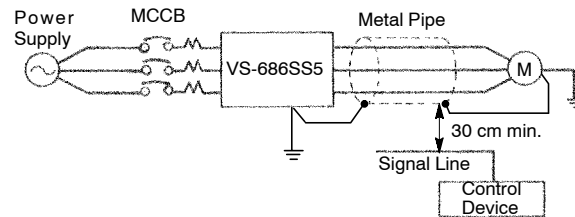

Fig. 13 Countermeasures Against Inductive Noise

(j) Countermeasures Against RFI Noise

RFI noise is generated from the inverter as well as from the input and output lines. To reduce RFI noise, install noise filters on both input and output sides, and also install in a totally enclosed steel box. The cable between the inverter and the motor should be as short as possible.

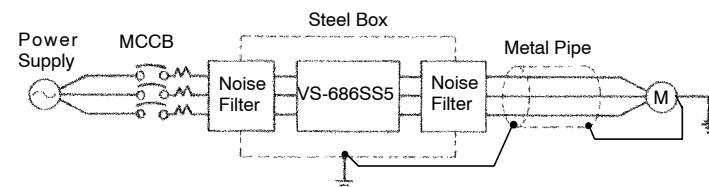

Fig. 14 Countermeasures Against RFI Noise

(k) Wiring Distance between Inverter and Motor

If the total wiring distance between inverter and motor is excessively long and the inverter carrier frequency (main transistor switching frequency) is high, harmonic leakage current from the cable will adversely affect the inverter and peripheral devices.

Consider the wiring distance between inverter and motor when increasing the carrier frequency value. Carrier frequency can be set by constant C6-02.

Table 2 Wiring Distance between Inverter and Motor

Wiring Distance between Inverter and Motor	Up to 50m	From 50m to 100m	More than 100m
Carrier Frequency (Set value of constant C6-02)	12kHz or less (Max. 12)	8kHz or less (Max. 8)	4kHz or less (Max. 4)

(3) Grounding

- Ground resistance
200V class : 100Ω or less, 400 V class : 10Ω or less.
- Never ground the inverter in common with welding machines, motors, or other large-current electrical equipment.
- Use the ground wires described in Table 5 or 6 and keep the length as short as possible.
- When using several inverter units side by side, ground the units as shown in Fig. 15, (a) or (b). Do not loop the ground wires as shown in (c).

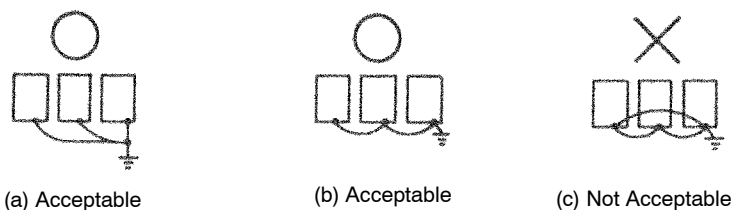

Fig. 15 Grounding of Three Inverter Units

(4) Functions of Main Circuit Terminals

The following table outlines the functions of the main circuit terminals. Wire according to each terminal function.

Table 3 200V Class Terminal Functions

Models CIMR-SSA □	20P4 to 27P5	2011 to 2015	2018 to 2022	2030 to 2075
Max Applicable Motor Output	0.4 to 7.5 kW	11 to 15 kW	18.5 to 22 kW	30 to 75 kW
R (L1)	Main circuit input power supply			
S (L2)				
T (L3)				
U (T1)	Inverter output			
V (T2)				
W (T3)				
B1	Braking resistor unit	—		
B2				
⊖	<ul style="list-style-type: none"> • DC reactor (⊕1 - ⊕2) • DC bus terminals (⊕1 - ⊖) 	<ul style="list-style-type: none"> • DC reactor (⊕1 - ⊕2) • DC bus terminals (⊕1 - ⊖)□ • Braking unit (⊕3 - ⊖) 	<ul style="list-style-type: none"> • DC bus terminals (⊕1 - ⊖) • Braking unit (⊕3 - ⊖) 	<ul style="list-style-type: none"> • Braking unit (⊕3 - ⊖) (⊕1 and ⊕2 terminals not provided) *
⊕ 1				
⊕ 2				
⊕ 3	—			
r	—		Cooling fan power supply	
Δ				
⊕	Ground terminal (Ground resistance : 100Ω or less)			

Table 4 400V Class Terminal Functions

Models CIMR-SSA □	40P4 to 4015	4018 to 4045	4055 to 4160	4220 to 4300	
Max Applicable Motor Output	0.4 to 15 kW	18.5 to 45 kW	55 to 160 kW	185 to 300 kW	
R (L1)	Main circuit input power supply				
S (L2)					
T (L3)					
U (T1)	Inverter output				
V (T2)					
W (T3)					
B1	Braking resistor unit	—			
B2					
⊖	<ul style="list-style-type: none"> • DC reactor (⊕1 - ⊕2) • DC bus terminals (⊕1 - ⊖) 	<ul style="list-style-type: none"> • DC bus terminals (⊕1 - ⊖) • Braking unit (⊕3 - ⊖) 	<ul style="list-style-type: none"> • Braking unit (⊕3 - ⊖) (⊕1 and ⊕2 terminals not provided) * 	<ul style="list-style-type: none"> • DC bus terminals (⊕1 - ⊖) • Braking unit (⊕3 - ⊖) (⊕2 terminal not provided) 	
⊕ 1					
⊕ 2					
⊕ 3	—				
Δ	—		Cooling fan power supply	—	
r			—	<ul style="list-style-type: none"> • Cooling fan power supply (Control power supply) r - Δ200 : 200 to 230 VAC input r - Δ400 : 380 to 460 VAC input 	
Δ 200					
Δ 400					
⊕	Ground terminal (Ground resistance : 10Ω or less)				

* The models of 200V 30 to 75kW or 400V 55 to 160kW cannot be connected with DC power supply. Terminal ⊕3 is for exclusive use for connecting a braking unit. Do not connect DC power supply to terminal ⊕3.

(5) Main Circuit Configuration

200V Class

CIMR-SSA20P4 to 21P5

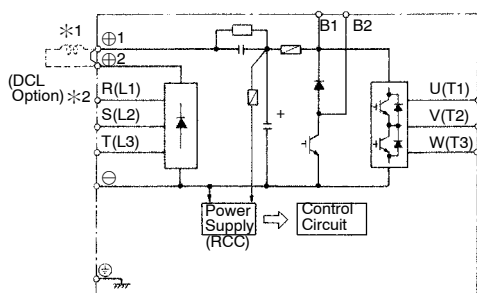

CIMR-SSA22P2 to 27P5

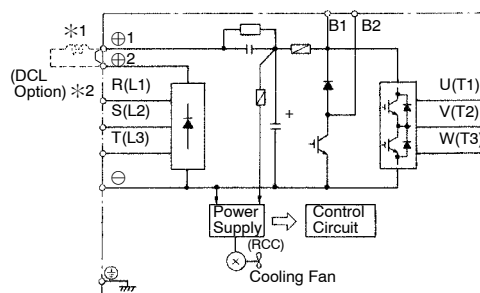

CIMR-SSA2011 to 2015

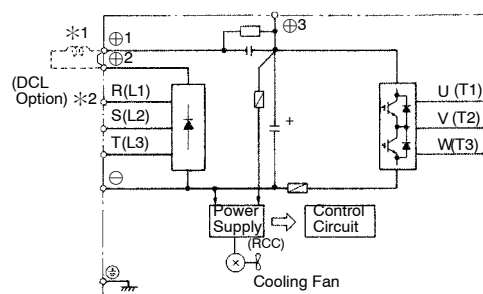

CIMR-SSA2018 to 2022

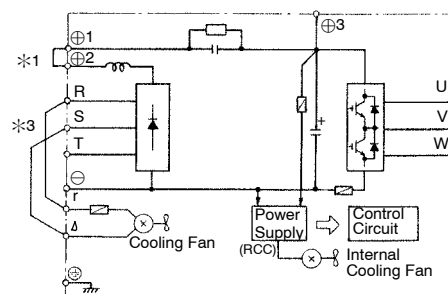

CIMR-SSA2030 to 2075

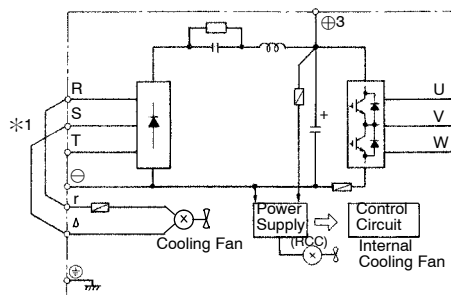

CIMR-SSAD030*4 to D045

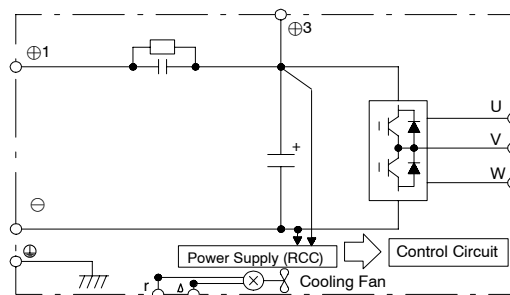

- *1: The wiring has been completed at the factory prior to shipping.
- *2: When installing a DC reactor (option) on models of 15kW or below, remove the short-circuit bar between ⊕1 and ⊕2 terminals and connect a DC reactor with the terminals.
- *3: The wiring has been completed at the factory prior to shipping. When using main circuit power supply as DC input, remove the wirings of R - r and S - Δ and connect AC power supply to r and Δ.
- *4: The CIMR-SSD030 motor is under development.

400V Class

CIMR-SSA40P4 to 41P5

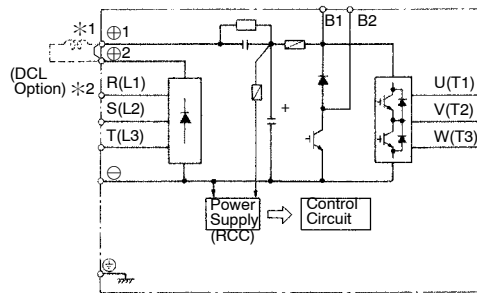

CIMR-SSA42P2 to 4015

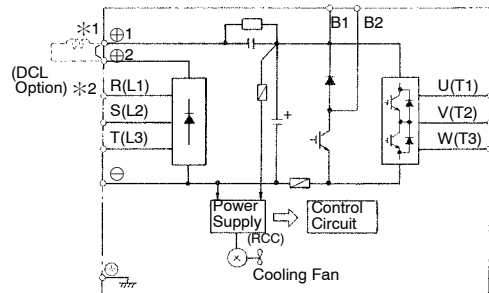

CIMR-SSA4018 to 4045

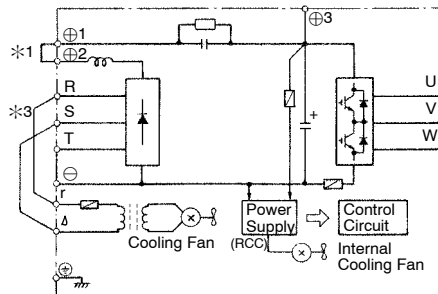

CIMR-SSA4055 to 4160

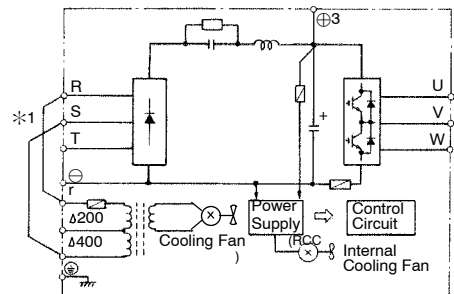

CIMR-SSA4220 to 4300

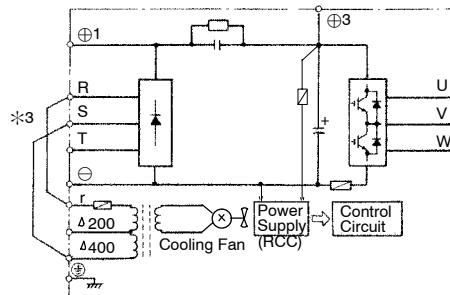

CIMR-SSAE075*4 to E110

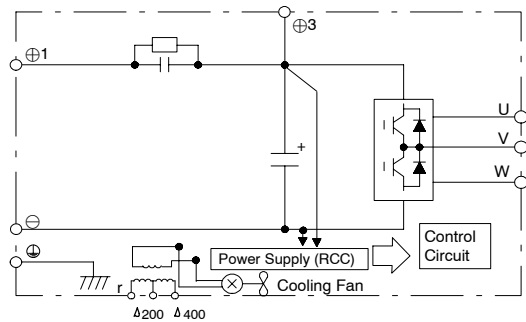

*1: The wiring has been completed at the factory prior to shipping.

*2: When installing a DC reactor (option) on models of 15 kW or below, remove the short-circuit bar between $\oplus 1$ and $\oplus 2$ terminals and connect a DC reactor with the terminals.

*3: The wiring has been completed at the factory prior to shipping. When using main circuit power supply as DC input, correct the wirings as follows.

- CIMR-SSA4018 to 4045

Remove the wirings of R - r and S - Δ and connect AC power supply to r and Δ .

- CIMR-SSA4220 to 4300

Remove the wirings of R - r and S - Δ 400 and connect AC power supply to r and Δ 400.

*4: The CIMR-SSAE075 motor is under development.

(6) Parts Required for Wiring

Select wires or closed-loop connectors to be used for wiring from Tables 5, 6 and 7.

Table 5 200V Class Wire Size

Circuit	Model CIMR- <input type="checkbox"/>	Terminal Symbol	Terminal Screw	Wire Size * mm ²	Wire Type
Main	SSA20P4	R, S, T, ⊖, ⊕ 1, ⊕ 2, B1, B2, U, V, W	M4	2 to 5.5	Power cable: 600V vinyl sheathed wire or equivalent
		⊕			
	SSA20P7	R, S, T, ⊖, ⊕ 1, ⊕ 2, B1, B2, U, V, W	M4	2 to 5.5	
		⊕			
	SSA21P5	R, S, T, ⊖, ⊕ 1, ⊕ 2, B1, B2, U, V, W	M4	2 to 5.5	
		⊕		3.5 to 5.5	
	SSA22P2	R, S, T, ⊖, ⊕ 1, ⊕ 2, B1, B2, U, V, W	M4	3.5 to 5.5	
		⊕			
	SSA23P7	R, S, T, ⊖, ⊕ 1, ⊕ 2, B1, B2, U, V, W	M4	5.5	
		⊕			
	SSA25P5	R, S, T, ⊖, ⊕ 1, ⊕ 2, B1, B2, U, V, W	M5	8	
		⊕		5.5 to 8	
	SSA27P5	R, S, T, ⊖, ⊕ 1, ⊕ 2, B1, B2, U, V, W	M5	8	
		⊕		5.5 to 8	
	SSA2011	R, S, T, ⊖, ⊕ 1, ⊕ 2, ⊕ 3, U, V, W	M6	22	
		⊕		8	
	SSA2015	R, S, T, ⊖, ⊕ 1, ⊕ 2, ⊕ 3, U, V, W	M8	30	
		⊕	M6	8	
	SSA2018	R, S, T, ⊖, ⊕ 1, ⊕ 2, ⊕ 3, U, V, W	M8	30	
		⊕		14	
r, Δ		M4	0.5 to 5.5		
SSA2022	R, S, T, ⊖, ⊕ 1, ⊕ 2, ⊕ 3, U, V, W	M8	38		
	⊕		14		
	r, Δ	M4	0.5 to 5.5		
SSA2030	R, S, T, U, V, W	M10	38 to 100		
	⊖, ⊕ 3	M8	—		
	⊕	M8	22		
	r, Δ	M4	0.5 to 5.5		
SSA2037	R, S, T, U, V, W	M10	38 to 100		
	⊖, ⊕ 3	M8	—		
	⊕	M8	22		
	r, Δ	M4	0.5 to 5.5		
SSA2045	R, S, T, U, V, W	M10	60 to 100		
	⊖, ⊕ 3	M8	—		
	⊕	M8	22		
	r, Δ	M4	0.5 to 5.5		
SSA2055	R, S, T, U, V, W	M10	100		
	⊖, ⊕ 3	M8	—		
	⊕	M8	30		
	r, Δ	M4	0.5 to 5.5		
SSA2075	R, S, T, U, V, W	M12	100 to 200		
	⊖, ⊕ 3	M8	—		
	⊕	M8	50		
	r, Δ	M4	0.5 to 5.5		
Control	Common to all models	1 to 33	M3.5	0.5 to 2	Twisted shielded wire

* Wire size is determined using 75°C temperature-rated copper wire.

When connecting a braking resistor unit or a braking unit, select wire size referring to the instructions of braking resistor unit and braking unit (manual No.: TOE-C726-2).

Table 6 400V Class Wire Size

Circuit	Model CIMR- <input type="text"/>	Terminal Symbol	Terminal Screw	Wire Size * mm ²	Wire Type
Main	SSA40P4	R, S, T, ⊖, ⊕ 1, ⊕ 2, B1, B2, U, V, W	M4	2 to 5.5	Power cable: 600V vinyl sheathed wire or equivalent
		⊕			
	SSA40P7	R, S, T, ⊖, ⊕ 1, ⊕ 2, B1, B2, U, V, W	M4	2 to 5.5	
		⊕			
	SSA41P5	R, S, T, ⊖, ⊕ 1, ⊕ 2, B1, B2, U, V, W	M4	2 to 5.5	
		⊕			
	SSA42P2	R, S, T, ⊖, ⊕ 1, ⊕ 2, B1, B2, U, V, W	M4	2 to 5.5	
		⊕			
	SSA43P7	R, S, T, ⊖, ⊕ 1, ⊕ 2, B1, B2, U, V, W	M4	2 to 5.5	
		⊕		3.5 to 5.5	
	SSA45P5	R, S, T, ⊖, ⊕ 1, ⊕ 2, B1, B2, U, V, W	M4	3.5 to 5.5	
		⊕			
	SSA47P5	R, S, T, ⊖, ⊕ 1, ⊕ 2, B1, B2, U, V, W	M5	5.5	
		⊕			
	SSA4011	R, S, T, ⊖, ⊕ 1, ⊕ 2, B1, B2, U, V, W	M5	8 to 14	
		⊕	M6	8	
	SSA4015	R, S, T, ⊖, ⊕ 1, ⊕ 2, B1, B2, U, V, W	M5	8 to 14	
		⊕	M6	8	
	SSA4018	R, S, T, ⊖, ⊕ 1, ⊕ 2, ⊕ 3, U, V, W	M6	14	
		⊕	M8	8	
		r, Δ	M4	0.5 to 5.5	
	SSA4022	R, S, T, ⊖, ⊕ 1, ⊕ 2, ⊕ 3, U, V, W	M6	22	
		⊕	M8	8	
		r, Δ	M4	0.5 to 5.5	
	SSA4030	R, S, T, ⊖, ⊕ 1, ⊕ 2, ⊕ 3, U, V, W	M8	22	
		⊕		8	
		r, Δ	M4	0.5 to 5.5	
	SSA4037	R, S, T, ⊖, ⊕ 1, ⊕ 2, ⊕ 3, U, V, W	M8	30	
		⊕		14	
		r, Δ	M4	0.5 to 5.5	
	SSA4045	R, S, T, ⊖, ⊕ 1, ⊕ 2, ⊕ 3, U, V, W	M8	50	
		⊕		14	
		r, Δ	M4	0.5 to 5.5	
SSA4055	R, S, T, U, V, W	M10	38 to 100		
	⊖, ⊕ 3	M8	—		
	⊕	M8	22		
	r, Δ 200, Δ 400	M4	0.5 to 5.5		
SSA4075	R, S, T, U, V, W	M10	38 to 100		
	⊖, ⊕ 3	M8	—		
	⊕	M8	22		
	r, Δ 200, Δ 400	M4	0.5 to 5.5		
SSA4110	R, S, T, U, V, W	M10	60 to 100		
	⊖, ⊕ 3	M8	—		
	⊕	M8	30		
	r, Δ 200, Δ 400	M4	0.5 to 5.5		
SSA4160	R, S, T, U, V, W	M12	100 to 200		
	⊖, ⊕ 3	M8	—		
	⊕	M8	50		
	r, Δ 200, Δ 400	M4	0.5 to 5.5		
SSA4220	R, S, T, ⊖, ⊕ 1, ⊕ 3, U, V, W	M16	325 or 200 × 2P		
	⊕	M8	60		
	r, Δ 200, Δ 400	M4	0.5 to 5.5		
SSA4300	R, S, T, ⊖, ⊕ 1, ⊕ 3, U, V, W	M16	250 × 2P or 325 × 2P		
	⊕	M8	60		
	r, Δ 200, Δ 400	M4	0.5 to 5.5		
Control	Common to all models	1 to 33	M3.5	0.5 to 2	Twisted shielded wire

* Wire size is determined using 75°C temperature-rated copper wire.

When connecting a braking resistor unit or a braking unit, select wire size referring to the instructions of braking resistor unit and braking unit (manual No.: TOE-C726-2).

Table 7 Closed-Loop Connectors

Wire Size mm ²	Terminal Screw	Closed-Loop Connectors
0.5	M3.5	1.25 - 3.5
	M4	1.25 - 4
0.75	M3.5	1.25 - 3.5
	M4	1.25 - 4
1.25	M3.5	1.25 - 3.5
	M4	1.25 - 4
2	M3.5	2 - 3.5
	M4	2 - 4
	M5	2 - 5
	M6	2 - 6
	M8	2 - 8
3.5 / 5.5	M4	5.5 - 4
	M5	5.5 - 5
	M6	5.5 - 6
	M8	5.5 - 8
8	M5	8 - 5
	M6	8 - 6
	M8	8 - 8
14	M6	14 - 6
	M8	14 - 8
22	M6	22 - 6
	M8	22 - 8
30 / 38	M8	38 - 8
50 / 60	M8	60 - 8
	M10	60 - 10
80	M10	80 - 10
100		100 - 10
100		100 - 12
150	M12	150 - 12
200		200 - 12
325		M12 × 2
	M16	325 - 16

NOTE

When determining wire size, consider voltage drop. Select a wire size so that voltage drop will be less than 2% of the normal rated voltage. Voltage drop is calculated by the following equation:

Phase-to-phase voltage drop (V)

$$= \sqrt{3} \times \text{wire resistance } (\Omega/\text{km}) \times \text{wiring distance (m)} \times \text{current (A)} \times 10^{-3}$$

3.4 WIRING THE CONTROL CIRCUIT

The following table outlines the functions of the control circuit terminals. Wire according to each terminal function.

(1) Functions of Control Circuit Terminals

Table 8 Control Circuit Terminals

Classification	Terminal	Signal Function	Description	Signal Level	
Sequence Input Signal	1	Forward run/stop	Forward run when closed, stop when open	Photo-coupler insulation Input : +24 VDC 8 mA	
	2	Reverse run/stop	Reverse run when closed, stop when open		
	3	External fault input	Fault when closed, normal state when open		
	4	Fault reset input	Reset when closed		
	5	Master/Auxiliary change (Multi-step speed reference 1)	Auxiliary speed reference when closed		
	6	Multi-step speed reference 2	Effective when closed		
	7	Jog reference	Jog run when closed		
	8	External baseblock	Inv. output stop when closed		
	11	0V for sequence input	—		
Analog Input Signal	15	+15 V Power supply output	For analog command +15 V power supply	+15 V (Allowable current 20 mA max.)	
	33	-15 V Power supply output	For analog command -15 V power supply	-15 V (Allowable current 20 mA max.)	
	13	Master speed reference	-10 to +10 V/-100% to +100%	-10 to +10 V (20 kΩ), 0 to +10 V (20 kΩ)	
	14		0 to +10 V/100%	0 to +10 V (20 kΩ)	
	16	Multi-function analog input	-10 to +10V/-100% to +100% 0 to +10 V/100%	Auxiliary analog input (H3-05)	4 to 20mA (250Ω) -10 to +10V (20kΩ), 0 to +10V (20kΩ)
	17	Common terminal for control circuit	—	—	—
12	Connection to shield sheath of signal lead or optional unit grounding	—	—	—	
Sequence Output Signal	9	During running (NO contact)	Closed when running	Multi-function output	Dry contact Contact capacity: 250 VAC 1 A or less 30 VDC 1 A or less
	10				
	25	Zero speed detection	Closed at zero-speed level (b2-01) or below	Open collector output 48 V 50 mA or less *	
	26	Speed agree detection	Closed when the speed reaches to ±2 Hz of set speed.		
	27	Open collector output common	—	—	—
	18	Fault contact output (NO/NC contact)	Fault when closed between terminals 18 and 20 Fault when open between terminals 19 and 20	—	Dry contact Contact capacity: 250 VAC 1 A or less 30 VDC 1 A or less
19					
20					
Analog Output Signal	21	Rotation speedometer output	0 to +10 V/100% rotation speed	Multi-function analog monitor 1 (H4-01,H4-02)	0 to ±10 V Max. ±5% 2 mA or less
	22	Common	—	—	
	23	Current monitor	5 V/inverter rated current	Multi-function analog monitor 2 (H4-04,H4-05)	

* When an inductive load such as a relay coil is driven, insert a fly-wheel diode as shown in the following figure.

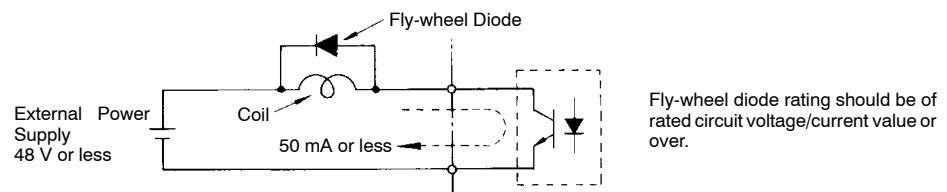

11	12(G)	13	14	15	16	17	25	26	27	33	18	19	20
1	2	3	4	5	6	7	8	21	22	23	9	10	

Fig. 16 Control Circuit Terminal Arrangement

(2) Precautions on Control Circuit Wiring

- Separate control circuit wires 1 to 33 from main circuit wires R, S, T, B1, B2, U, V, W, \ominus , $\oplus 1$, $\oplus 2$, $\oplus 3$ and other power cables to prevent erroneous operation caused by noise interference.
- Separate the wiring of control circuit terminals 9, 10, 18, 19 and 20 (contact output) from those of terminals 1 to 8, 21, 22, 23, 25, 26, 27, 33 and 11 to 17.
- Use twisted shielded or twisted-pair shielded wire for the control circuit line and connect the shield sheath to the inverter terminal 12. See Fig. 17. Wiring distance should be less than 50 m.

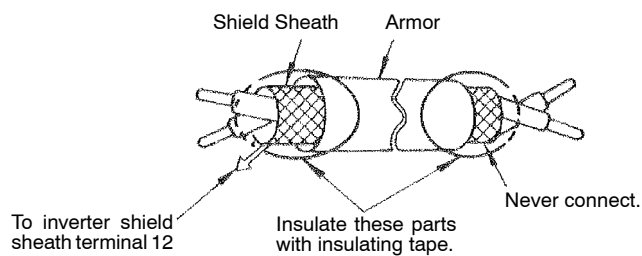

Fig. 17 Shielded Wire Termination

3.5 WIRING INSPECTION

After completing of installation and wiring, check for the following items. Never use control circuit buzzer check.

- Wiring is proper.
- Wire clippings or screws are not left in the unit.
- Screws are securely tightened.
- Bare wire in the terminal does not contact other terminals.

4 OPERATION



WARNING

- Only turn ON the input power supply after replacing the front cover. Do not remove the cover while current is flowing.
Failure to observe this warning can result in an electric shock.
- When the retry function (L5-02) is selected, do not approach the inverter or the load, since it may restart suddenly after being stopped.
(Construct machine system, so as to assure safety for personnel, even if the inverter should re-start.) Failure to observe this warning can result in personal injury.
- Since the stop button can be disabled by a function setting, install a separate emergency stop switch.
Failure to observe this warning can result in personal injury.
- If an alarm is reset with the operation signal ON, the inverter restarts automatically. Only reset the alarm after verifying that the operation signal is OFF.
Failure to observe this warning can result in personal injury.



CAUTION

- Never touch the heatsink or discharging resistor since the temperature is very high.
Failure to observe this caution can result in harmful burns to the body.
- Since it is easy to change operation speed from low to high speed, verify the safe working range of the motor and machine before operation.
Failure to observe this caution can result in personal injury and machine damage.
- Install a holding brake separately if necessary.
Always construct the external sequence to confirm that the holding brake is activated in the event of an emergency, a power failure, or an abnormality in the inverter occurring.
Failure to observe this caution can result in personal injury.
- If using with an elevator, take safety measures on the machine's side to prevent the elevator from dropping.
Failure to observe this caution can result in personal injury.
- Do not change signals during operation.
The machine or the inverter may be damaged.
- All the constants of the inverter have been preset at the factory. Do not change the settings unnecessarily.
The inverter may be damaged. For supply voltage, follow Par. 4.2.
- Be sure to set the motor constants in accordance with the values listed on the motor nameplate.
Failure to observe this caution may cause the torque to be insufficient, which may result in the following motor malfunctions:
 - The motor is pulled in the direction of the load.
 - The motor rotates in reverse.
 - The motor does not rotate.
 - The motor suddenly accelerates.

4.1 TEST RUN CHECKPOINTS

Check the following items before a test run.

- Wiring and terminal connections are correct.
- No short circuit caused by wire clippings.
- Screw-type terminals are securely tightened.
- Motor is securely mounted.

4.2 SETTING THE LINE VOLTAGE USING JUMPER (FOR 400V CLASS 18.5kW AND ABOVE)

Insert the jumper at the appropriate location corresponding to the input line voltage. (See Fig. 18.)
It has been preset at the factory to 440V.

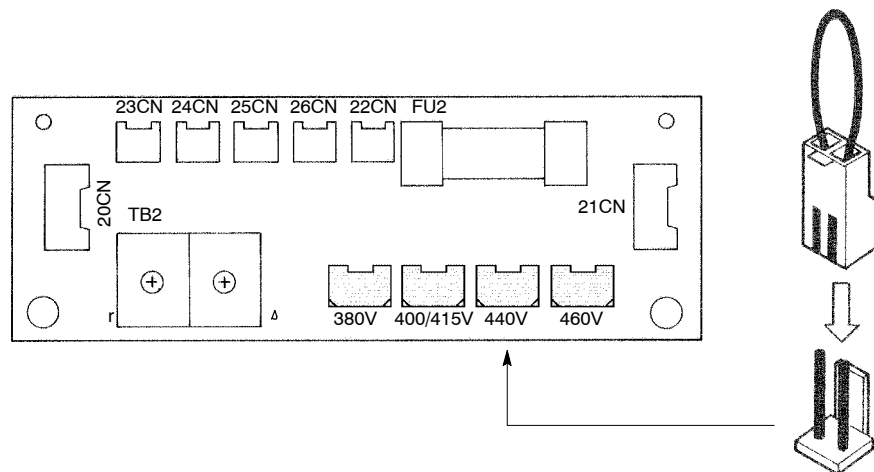

Fig. 18 Line Voltage Jumper (For 400V Class 18.5kW to 45kW)

4.3 TEST RUN

(1) Digital Operator Display at Power ON

When the system is ready for operation, turn ON the power supply. Verify that the inverter powers up properly. If any problems are found, turn OFF the power supply immediately.

The digital operator display illuminates as shown below when turning the power supply ON. Refer to Section 3 for operation method of digital operator.

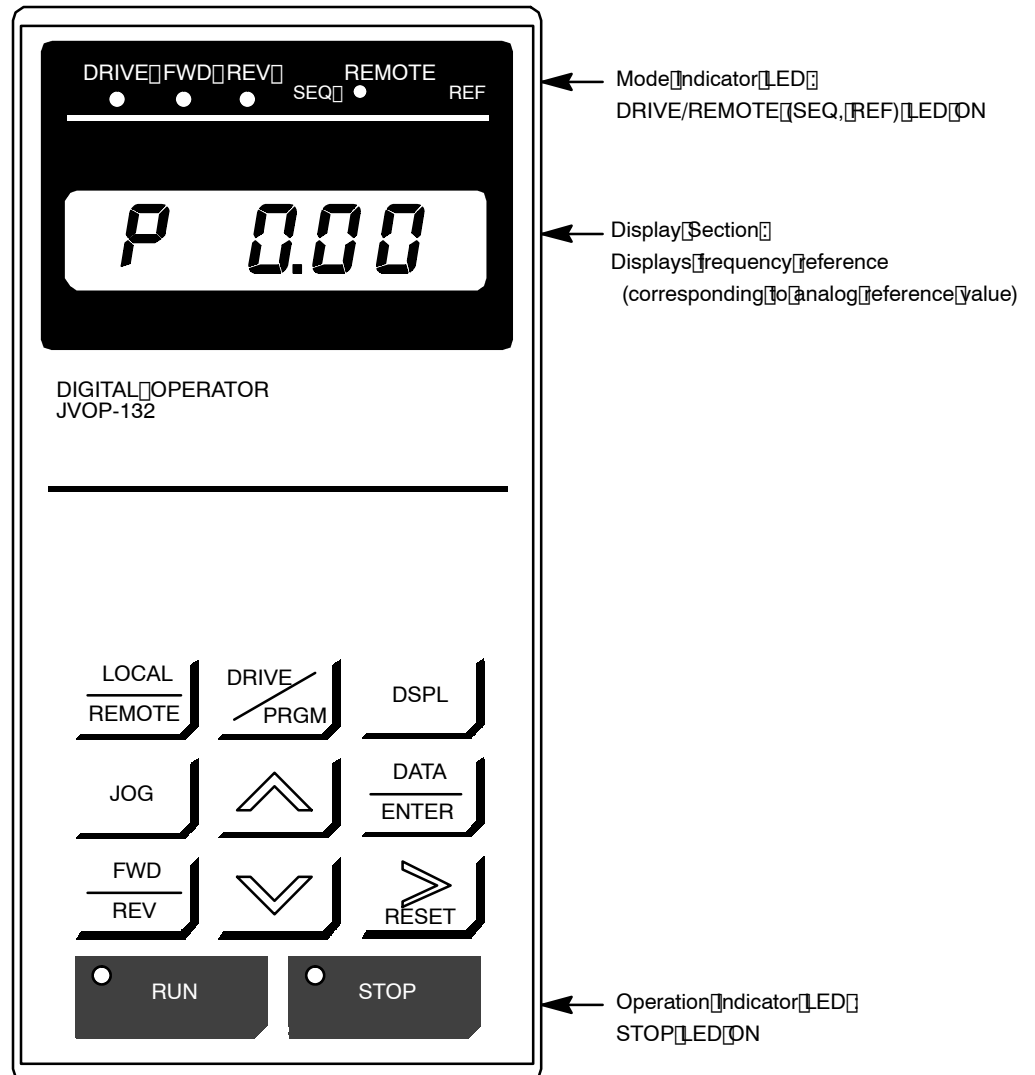

Fig. 19 Digital Operator Display at Power ON

(2) OPERATION MODE SELECTION

The VS-686SS5 has two operation modes, LOCAL and REMOTE, as described below. These two modes can be selected by the digital operator “LOCAL/REMOTE” key only while the operation is stopped. The selected operation mode can be verified by observing the digital operator SEQ and REF LEDs (both LEDs light in REMOTE mode).

The operation mode at power ON is set to REMOTE (run by control circuit terminals 13 and 14 speed reference and run command from a control circuit terminal) prior to shipment. Multi-function contact inputs from control circuit terminals 3 to 8 are enabled in both operation modes LOCAL/REMOTE.

LOCAL	Both speed reference and run command are set by the digital operator. SEQ and REF LEDs go OFF.
REMOTE	Master speed reference and run command can be selected by setting constants b1-01 and b1-02. The factory setting is “1” (command from control circuit terminal).

Table 9 Reference Selection in REMOTE Mode

Constant No.	Name	Remarks
b1-01	Speed reference selection	0 : Master speed reference from digital operator (d1-01) (Digital operator REF LED is OFF.) 1 : Master speed reference from control circuit terminals 13 and 14 (Digital operator REF LED is ON.) 2 : Not used. 3 : Master speed reference set by transmission option (CP-916 B/G, 216 I/F) (Digital operator REF LED is ON.) 4 : Master speed reference set by personal computer (CP-717). (Digital operator REF LED is ON.)
b1-02	Run command selection	0 : Run command from digital operator (Digital operator SEQ LED is OFF.) 1 : Run command from control circuit terminal (Digital operator SEQ LED is ON.) 2 : Not used. 3 : Run command from transmission option (CP-916 B/G, 216 I/F) (Digital operator SEQ LED is ON.) 4 : Run command set by personal computer (CP-717). (Digital operator SEQ LED is ON.)

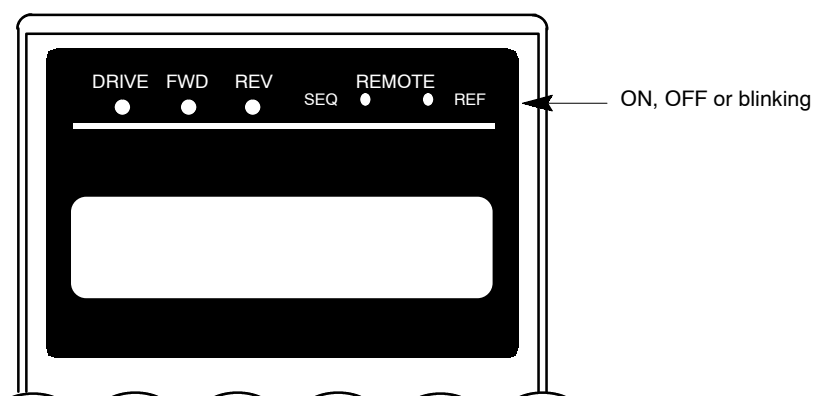

(3) Setting and Verification before Operation

NOTE

When setting up the VS-686SS5, make sure to follow the procedures below. Mistakes in set-up order may cause values to be written over resulting in poor operation.

- STEP 1 Control method setting (Page 43)
- STEP 2 Constant torque/variable torque motor settings (Pages 44 to 47)
- STEP 3 Motor capacity selection (Pages 44 to 47)
- STEP 4 Nameplate value setting (Pages 44 to 47)

The VS-686SS5 is equipped with two current vector control methods (with or without PG). Either method can be easily selected by using the digital operator to meet user application needs. Open loop vector control is set at the factory prior to shipment. In the following cases, follow the procedures below to set and verify the control method and motor related constants.



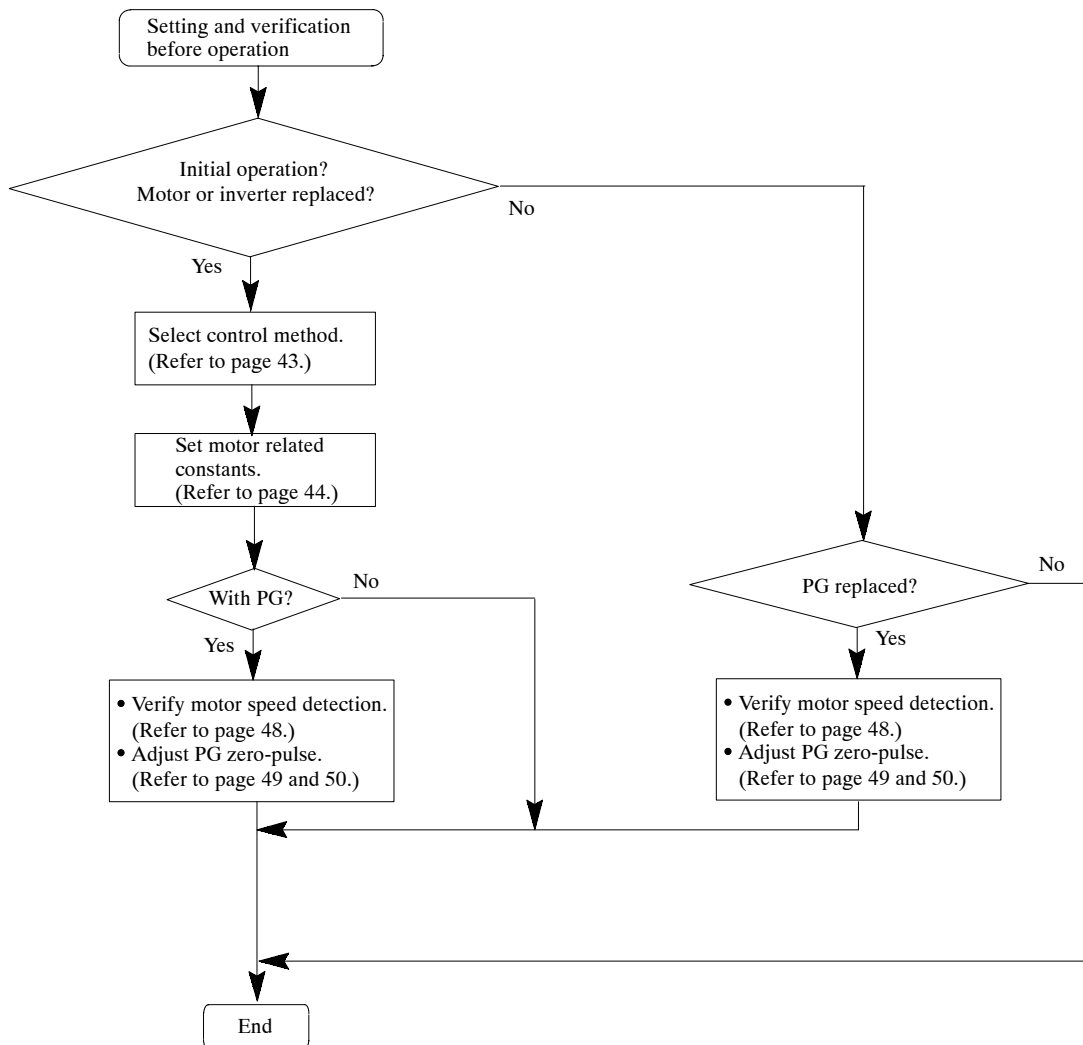







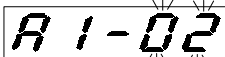

- When conducting initial operation of the VS-686SS5.
- When replacing either motor or inverter
- When replacing PG

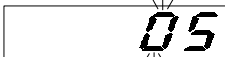

(a) Control Method Selection

The following procedures show how to change the control method from open loop vector to flux vector.

Table 10 Control Method Selection/Change

Step	Description	Key Sequence	Digital Operator Display
①	Power ON • Displays speed reference value.		 REMOTE LEDs (SEQ, REF) ON
②	Control method selection • Move to program mode.		Constant No. display
③	• Move to control method selection (A1-02).		
④	• Verify the set value.		 (Initial setting: open loop vector)
⑤	• Change to flux vector.		
⑥	• Write-in the value.		 Displays for 0.5 seconds.
			 Setting completed.
⑦	Return to drive mode.		

(b) Setting Motor Constants



CAUTION

- Be sure to set the motor constants before the initial operation and after replacement of the motor. Reconfirm the motor constants after they have been set. Failure to observe this caution may result in motor malfunctions such as sudden acceleration.
- In the following cases when under flux vector control, be sure to adjust the PG zero-pulse as described in 4.3 (3) (e) PG Zero-pulse Adjustment:
 - Before initial operation.
 - After replacing the motor.
 - After replacing the PG.

Set the motor constants in accordance with the values listed on the motor nameplate.

If the open loop vector control is selected, set the motor constants in the order shown in Table 11.

If the flux vector control is selected, set the motor constants in the order shown in Table 12.

If the setting of the motor capacity selection (E1-02) is changed, the motor constants will return to their initial values.

Main Nameplate

VARISPEED-686SS5						PARAMETER	
3-PHASE PERMANENT MAGNET MOTOR						R ₁	E1-09
TYPE				POLES		E1-05	
PROTECTION		COOLING				L _d	E1-10
kW	V	Hz	RATING	A	r/min	L _q	E1-11
	E1-03			E1-04	E1-06, 07	K _e	E1-13
	E1-03			E1-04	E1-07	Δθ	C2-12, 13
INS.		COOLANT TEMP.		°C		ALTITUDE	
STD				m		K _i	C3-02
BRG NO		MASS		kg		K _t	C3-03
SER NO				YEAR		S _i	B3-03
YASKAWA ELECTRIC CORPORATION JAPAN							

Fig. 20 Example of Motor Nameplate

Table 11 Motor Constants Setup for Open Loop Vector Control

Constant No.	Name	Set Value (On Nameplate)	Remarks	Checked
A1-01	Constant access level	4	—	
A1-02	Control method selection	5	5: Open loop vector control	
E1-02	Motor capacity selection	See remarks.	Refer to Table A-6 Motor Capacity Selection List in Appendix 4.	
E1-03	Motor rated voltage	(V)	If two values for (V) are shown on the nameplate, set E1-03 to the value in the lower row.	
E1-04	Motor rated current	(A)	If two values for (A) are shown on the nameplate, set E1-04 to the value in the lower row.	
E1-05	Number of motor poles	(POLES)	If (POLES) is not shown on the nameplate, set E1-05 to 6.	
E1-06	Motor max. speed	(r/min) or (min ⁻¹)	If two values are shown for (r/min) or (min ⁻¹), set E1-06 to the value in the upper row.	
E1-07	Motor base speed	(r/min) or (min ⁻¹)	If two values are shown for (r/min) or (min ⁻¹), set E1-07 to the value in the lower row.	
E1-08	Motor min. speed	10% of the base speed or higher	Initial setting: 10% of base speed.	
E1-09	Motor armature resistance	(R1)	—	
E1-10	Motor d-axis inductance	(Ld)	—	

Constant No.	Name	Set Value (On Nameplate)	Remarks	Checked
E1-11	Motor q-axis inductance	(Lq)	—	
E1-13	Induced voltage	(Ke)	—	
C2-12	Leading phase compensation amount	($\Delta\theta$)	—	
E1-14	Variable torque/constant torque selection	See remarks.	If the motor model starts with SSR, E1-14 = 0. If the motor model starts with SST, E1-14 = 1.	

Table 12 Motor Constants Setup for Flux Vector Control

Constant No.	Name	Set Value (On Nameplate)	Remarks	Checked
A1-01	Constant access level	4	—	
A1-02	Control method selection	6	6: Flux vector control	
E1-02	Motor capacity selection	See remarks.	Refer to Table A-6 Motor Capacity Selection List in Appendix 4.	
E1-03	Motor rated voltage	(V)	If two values for (V) are shown on the nameplate, set E1-03 to the value in the lower row.	
E1-04	Motor rated current	(A)	If two values for (A) are shown on the nameplate, set E1-04 to the value in the lower row.	
E1-05	Number of motor poles	(POLES)	If (POLES) is not shown on the nameplate, set E1-05 to 6.	
E1-06	Motor max. speed	(r/min) or (min^{-1})	If two values are shown for (r/min) or (min^{-1}), set E1-06 to the value in the upper row.	
E1-07	Motor base speed	(r/min) or (min^{-1})	If two values are shown for (r/min) or (min^{-1}), set E1-07 to the value in the upper row.	
E1-08	Motor min. speed	Any value between 0 and the base speed	Initial setting: 30 min^{-1}	
E1-09	Motor armature resistance	(R1)	—	
E1-10	Motor d-axis inductance	(Ld)	—	
E1-11	Motor q-axis inductance	(Lq)	—	
E1-13	Induced voltage	(Ke)	—	
C2-13	PG zero-pulse compensation amount	($\Delta\theta$)	If the PG zero-pulse is adjusted, the set value of C2-13 changes.	
E1-14	Variable torque/constant torque selection	1	—	
—	Motor speed detection check	—	Check if the motor speed is detected correctly as explained in 4.3 (3) (d).	
—	PG zero-pulse adjustment	—	Adjust the PG zero-pulse as explained in 4.3 (3) (e).	

The following procedures show how to change variable torque motor selection to constant torque motor selection and set the motor related constants.

Table 13 Motor Related Constants Setting

Step	Description	Key Sequence	Digital Operator Display
①	Power ON • Displays speed reference value.		 REMOTE LEDs (SEQ, REF) ON.
②	Move to program mode. When inputting the values other than motor nameplate values, execute steps ③ to ⑦ below.		Constant No. display
③	• Move to access level (A1-01).		
④	• Verify the set value.		
⑤	• Change to ADVANCED.		
⑥	• Write-in the value.		 Displays for 0.5 seconds. Setting completed.
⑦	• Return to constant No. display.		
⑧	Variable torque/constant torque motor selection • Move to variable torque/constant torque motor selection (E1-14).		
⑨	• Verify the set value.		 (Initial setting: variable torque motor)
⑩	• Select constant torque motor.		
⑪	• Write-in the value.		 Displays for 0.5 seconds. Setting completed.
⑫	• Return to constant No. display.		

(Cont'd)

Step	Description	Key Sequence	Digital Operator Display
⑬	Motor capacity selection setting <ul style="list-style-type: none"> • Move to motor capacity selection (E1-02). 		
⑭	<ul style="list-style-type: none"> • Verify the set value of motor capacity selection. 		 (Example: 200V 1750 min ⁻¹ 7.5kW)
⑮	<ul style="list-style-type: none"> • Set correct value. (Refer to Table A-6 for the set value of motor capacity selection.) 		 (Example: 200V 1450 min ⁻¹ 7.5kW)
⑯	<ul style="list-style-type: none"> • Write-in the value. 		 Displays for 0.5 seconds.
			 Setting completed.
⑰	<ul style="list-style-type: none"> • Return to constant No. display. 		
⑱	Motor rated current setting <ul style="list-style-type: none"> • Move to motor rated current (E1-04). 		
⑲	<ul style="list-style-type: none"> • Verify the set value. 		 (Example: 200V 1450 min ⁻¹ 7.5kW)
⑳	<ul style="list-style-type: none"> • Set rated current according to value on motor nameplate. 		
㉑	<ul style="list-style-type: none"> • Write-in the value. 		 Displays for 0.5 seconds.
			 Setting completed.
㉒	<ul style="list-style-type: none"> • Return to constant No. display. 		
㉓	<ul style="list-style-type: none"> • Repeat the same procedures for ⑱ to ㉑ as for E1-09, 10, 11, 13. (Add C2-12 setting in open loop vector control.) Furthermore, when using a special motor, set motor base min⁻¹ (E1-07) and motor maximum min⁻¹ (E1-06). 	⋮	⋮
㉔	<ul style="list-style-type: none"> • Return to constant No. display. 		
㉕	Return to drive mode.		

(c) Setting the Carrier Frequency

NOTE

When changing the carrier frequency, contact your YASKAWA representative. To reduce noise level by increasing the carrier frequency, it will be necessary to lower the rated current.

To reduce the motor noise during operation, change the setting of constant C6-02 (carrier frequency selection). Note that this is not possible for all types of inverters. Table 14 shows whether or not noise reduction is possible by changing the setting of C6-02. Carrier frequency is set at 2 kHz at the factory.

The setting range of the carrier frequency is indicated in Table 14.

Table 14 Setting the Carrier Frequency

Inverter Model CIMR-SSA()	Setting Range of Carrier Frequency *	Remarks
20P4 to 2018	High ← 2, 4, 8, 12 kHz Magnetic noise → Low	—
40P4 to 4030		
2022 to 2075	High ← 2, 4, 8 kHz Magnetic noise → Low	12 kHz cannot be set.
4037 to 4075		
4110 to 4160		
4185 to 4300	Only 2 kHz can be set.	—

*Carrier frequency lower limit is 2.0 kHz.

(d) Checking the Motor Speed Detection (For Flux Vector Control)

⚠ CAUTION

- Verify that digital operator STOP LED is ON before checking motor speed detection.
- Verify that nothing is caught on the shaft or coupling.

When the control method is flux vector, select motor speed display on the digital operator display and check the followings as shown in Table 15.

- Turn the motor shaft manually and verify that display of motor rotation direction and polarity is correct.
- Motor speed is displayed correctly.

Forward run: Clockwise as viewed from the opposite load side (standard setting).
See Fig. 21.

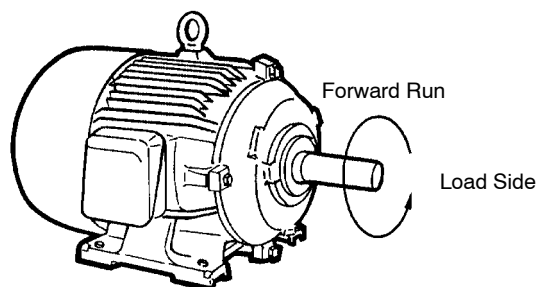









Fig. 21 Motor Rotation Direction

Table 15 Checking the Motor Speed Detection

Step	Description	Key Sequence	Digital Operator Display
①	Power ON • Displays speed reference value.		 REMOTE LEDs (SEQ, REF) ON.
②	Change the display to motor speed.		
③	Turn the motor shaft counterclockwise as viewed from the load side. (If the motor is supposed to rotate clockwise in a forward operation, turn the motor shaft clockwise as viewed from the load side.)		(Ex.)  Make sure the displayed rotation direction is forward and the displayed motor speed corresponds to the present rotating speed.
④	Turn the motor shaft clockwise as viewed from the load side. (If the motor is supposed to rotate counterclockwise in a forward operation, turn the motor shaft clockwise as viewed from the load side.)		(Ex.)  Make sure the displayed rotation direction is reverse and the displayed motor speed corresponds to the present rotating speed.
⑤	Return the display to speed reference value.	 Depress four times.	

In case of motor speed malfunctions, refer to the table below for corrective actions.

Fault Contents	Corrective Actions
Motor speed displays in reverse polarity.	<ul style="list-style-type: none"> • If the motor is supposed to rotate counterclockwise in a forward operation, set F1-05 = 1. • If the motor is supposed to rotate clockwise in a forward operation, set F1-05 = 0. • Connect the PG cable to the correct terminal. (Refer to page 22.)
Motor speed displays 0 or other incorrect value.	Connect the PG cable to the correct terminal. (Refer to page 22.)

(e) PG Zero-pulse Adjustment (For Flux Vector Control)



WARNING

- When adjusting PG zero-pulse, disconnect the motor from the machine. The motor rotates automatically during adjustment.
- When PG zero-pulse adjustment is completed, "End" is displayed on the digital operator. Do not touch it until it has come to a complete stop. The motor starts and stops repeatedly when adjustments are made.



CAUTION

- Confirm safety.
 - Is the motor disconnected from the machine?
 - Is the lock key disconnected from the machine?
 - Are there any persons or objects near the motor shaft?
 - Has the motor come to a complete stop?

NOTE

Adjust zero-pulse when replacing PG or motor (i.e. when relative position of connection between motor and PG).

The operation pattern below shows PG zero-pulse adjustment method. If an error is displayed during adjustment, refer to APPENDIX 5.

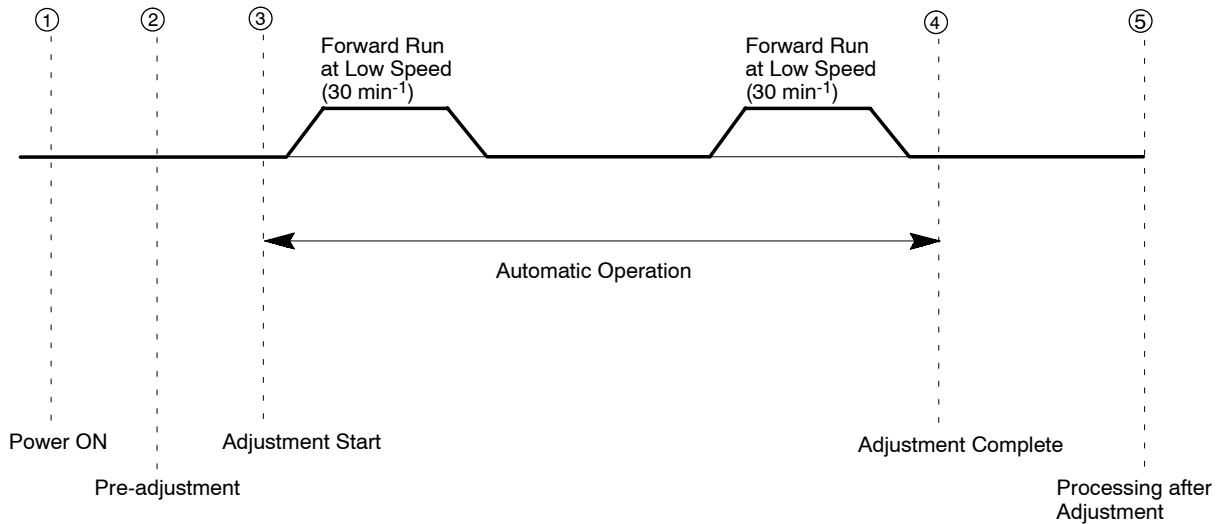







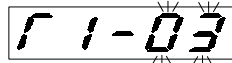











Fig. 22 Operation Pattern of PG Zero-pulse Adjustment

Table 16 PG Zero-pulse Adjustment

Step	Description	Key Sequence	Digital Operator Display
①	Power ON • Displays speed reference value.		 REMOTE LEDs (SEQ, REF) ON. A1-02=06 (Control method: flux vector)
②	Pre-adjustment • Move to program mode. • Move to tuning item selection (T1-03). • Verify the set value. (Go to * for "01.") • Change the value to "01" (adjusting of PG zero-pulse only). • Write-in the value.	 	Constant No. display Displays for 0.5 seconds.

(Cont'd)

Step	Description	Key Sequence	Digital Operator Display
*	<ul style="list-style-type: none"> Return to constant No. display. Move to tuning mode (T1-02). Verify the set value. Change the value to "02" (tuning mode). Write-in the value. Return to drive mode. 	      	 Setting completed.      Displays for 0.5 seconds.  Setting completed.   Automatic adjustment during blinking  Displays for 2 seconds.  Adjustment completed.
③	Adjustment start		
④	Adjustment completed		

Note: After verifying the set value of C2-13, write the value in Table A-7 in APPENDIX 5.

(4) Jog Operation

The operation pattern below shows jog operation by using digital operator. The numbers in the diagram correspond to the step numbers in Table 17.

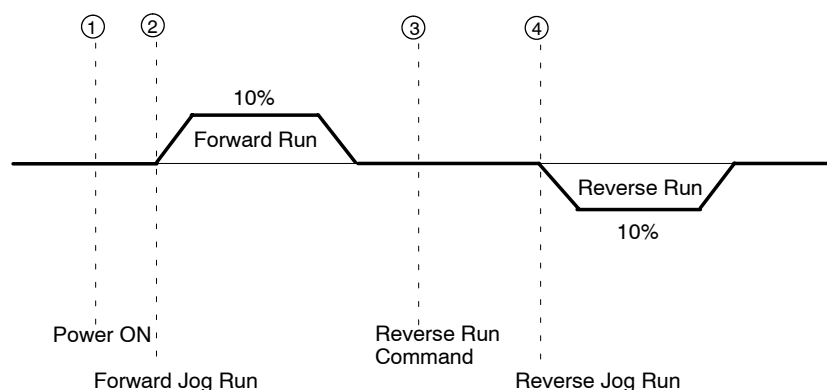

Fig. 23 Operation Sequence by Using Digital Operator (Jog Operation)

Table 17 Jog Operation by Using Digital Operator

Step	Description	Key Sequence	Digital Operator Display
①	Power ON <ul style="list-style-type: none"> Displays speed reference value. Operation Condition Setting <ul style="list-style-type: none"> Select LOCAL mode. 	<div style="border: 1px solid black; padding: 2px; display: inline-block;">LOCAL REMOTE</div>	<div style="border: 1px solid black; padding: 5px; text-align: center;"> P 0.00 REMOTE LEDs (SEQ, REF) ON. <div style="border: 1px solid black; padding: 2px; display: inline-block;">P00.00</div> REMOTE LEDs (SEQ, REF) OFF FWD LED ON REV LED OFF </div>
②	Forward jog run (10%) <ul style="list-style-type: none"> Perform jog run. (Runs while depressing JOG key. Motor rotates at low speed.) Depress the key for 2 seconds or longer to check the operation. 	<div style="border: 1px solid black; padding: 2px; display: inline-block;">JOG</div>	<div style="border: 1px solid black; padding: 5px; text-align: center;"> <div style="border: 1px solid black; padding: 2px; display: inline-block;">P 10.00</div> FWD LED ON REV LED OFF </div>
③	Reverse run command <ul style="list-style-type: none"> Switch to reverse run. 	<div style="border: 1px solid black; padding: 2px; display: inline-block;">FWD REV</div>	<div style="border: 1px solid black; padding: 5px; text-align: center;"> <div style="border: 1px solid black; padding: 2px; display: inline-block;">P00.00</div> FWD LED OFF REV LED ON </div>
④	Reverse jog run (10%) <ul style="list-style-type: none"> Perform jog run. (Runs while depressing JOG key. Motor rotates at low speed.) 	<div style="border: 1px solid black; padding: 2px; display: inline-block;">JOG</div>	<div style="border: 1px solid black; padding: 5px; text-align: center;"> <div style="border: 1px solid black; padding: 2px; display: inline-block;">P 10.00</div> FWD LED OFF REV LED ON </div>

Note: When the constant E1-05 (Operation selection for setting of E1-08 or less) is 1 (base lock) and the constant E1-08 is set to 30 min or more, reset E1-08 to 0 and then adjust the PG zero-pulse. After adjusting the PG zero-pulse, return the constant E1-08 to the previous setting.

(5) Example of Basic Operation

NOTE

Check the following items during operation.

- Motor rotates smoothly.
- Motor rotates in the correct direction.
- Motor does not have abnormal vibration or noise.
- Acceleration and deceleration are smooth.
- Current matches the load flow.
- Status indicator LEDs and digital operator display are correct.

(a) Operation by Digital Operator

The diagram below shows a typical operation pattern using the digital operator. The numbers in the diagram correspond to the step numbers in Table 18.

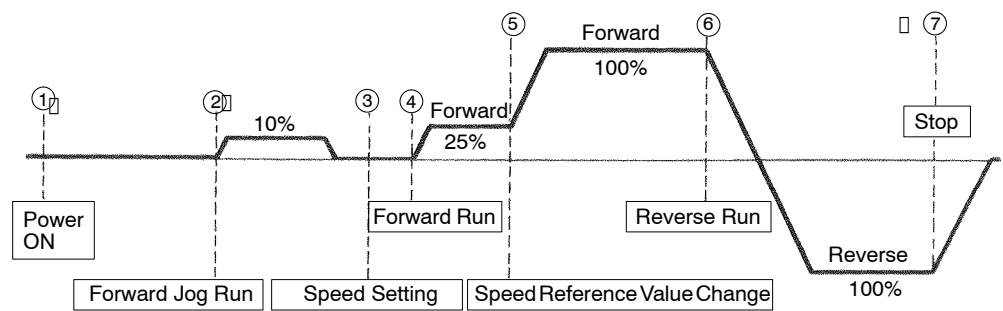

Fig. 24 Operation Sequence by Digital Operator

Table 18 Typical Operation by Digital Operator

Step	Description	Key Sequence	Digital Operator Display
①	Power ON <ul style="list-style-type: none"> Displays speed reference value. 		
	Operation condition setting <ul style="list-style-type: none"> Select LOCAL mode. 		REMOTE LED (SEQ, REF) ON
②	Forward jog run (10%) <ul style="list-style-type: none"> Perform jog run. (Runs while depressing JOG key. Motor rotates at low speed.) 		
③	Speed Setting <ul style="list-style-type: none"> Displays speed reference value. Change the value. Write-in the value. Select motor speed monitor display. 	Change the value by depressing 	
			 (Displays for 2 seconds.)
			 RUN LED ON FWD LED ON
④	Forward run <ul style="list-style-type: none"> Perform forward run. (25%) 		
	Speed reference value change (25% → 100%) <ul style="list-style-type: none"> Select speed reference value display. Change the value. Write-in the value. (Motor min⁻¹ increases.) Select motor speed monitor display. 	 Depress 4 times.	
		Change the value by depressing 	 Digit to be changed blinks.
			 (Displays for 2 seconds.)
⑤	Reverse run <ul style="list-style-type: none"> Switch to reverse run. Motor decelerates to stop. Then reverse run starts at set min⁻¹ of 100%. 		 REV LED ON
	Stop <ul style="list-style-type: none"> Decelerates to stop. 		 STOP LED ON (RUN LED blinks during deceleration.)

(b) Operation by Control Circuit Terminal Signal

The diagram below shows a typical operation pattern using the control circuit terminal signals. The numbers in the diagram correspond to the step numbers in Table 19.

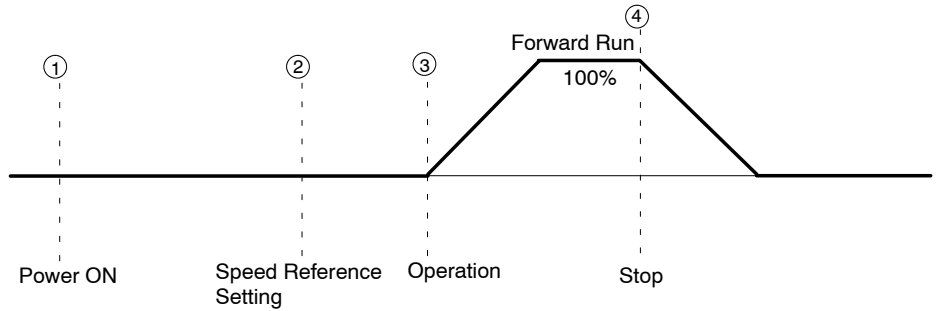

Fig. 25 Operation Sequence by Control Circuit Terminal Signal

Table 19 Typical Operation by Control Circuit Terminal

Step	Description	Key Sequence	Digital Operator Display
①	Power ON • Displays speed reference value.		 REMOTE LED (SEQ, REF) ON
②	Speed reference setting • Input speed reference voltage by control circuit terminal 13 or 14 and verify the input value on the digital operator. • Switch to motor speed display.		 Voltage: 10V
③	Forward run command • Close between control circuit terminals 1 and 11 to perform forward run.		 RUN LED ON FWD LED ON
④	Stop • Open between control circuit terminals 1 and 11 to stop operation.		STOP LED ON (RUN LED blinks during deceleration.)

5 SETTING OPERATION CONDITIONS

5.1 DIGITAL OPERATOR KEY DESCRIPTION

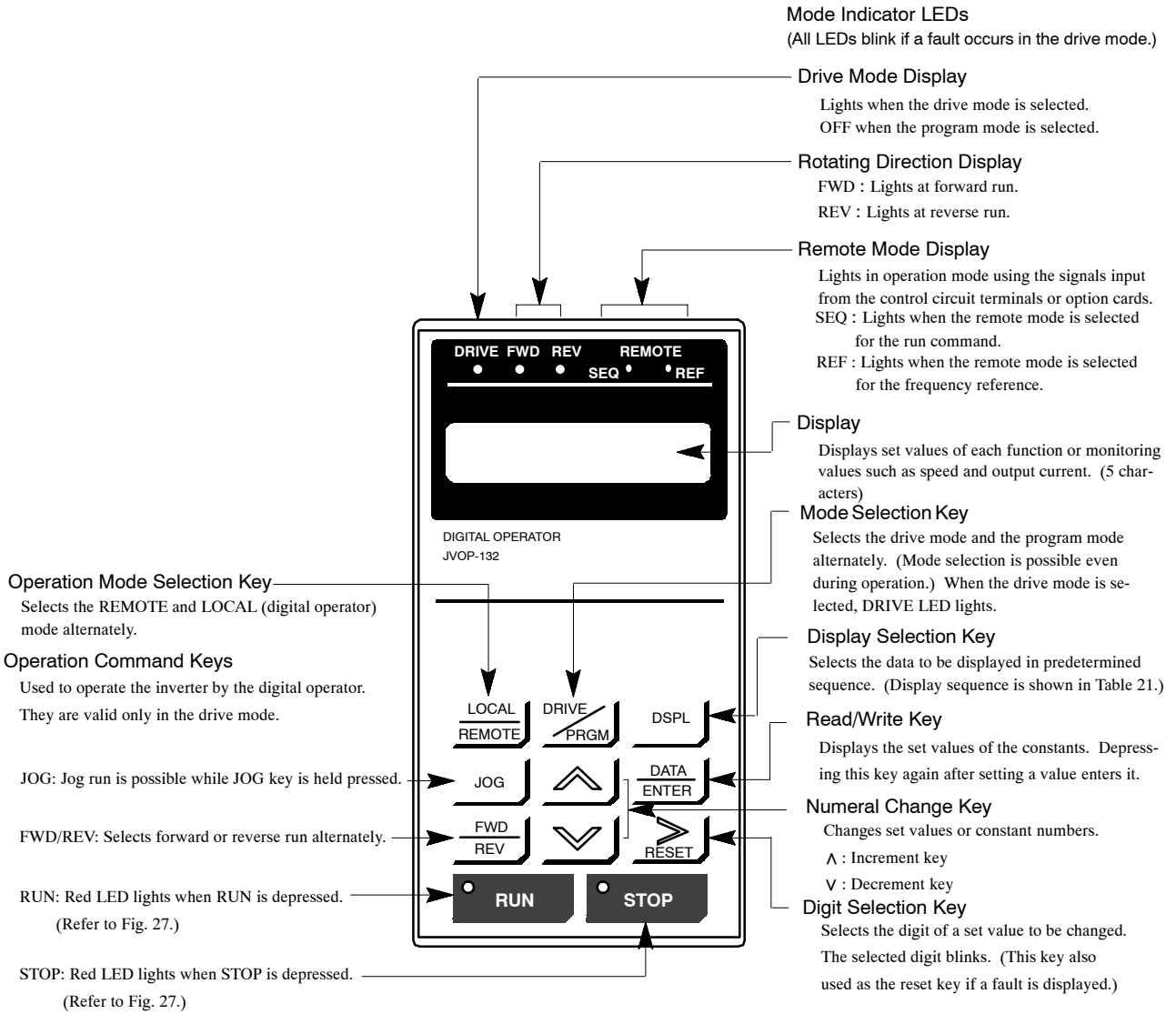

Fig. 26 Digital Operator Key Description

RUN and STOP LEDs light, blink, and go OFF depending on the status of operation.

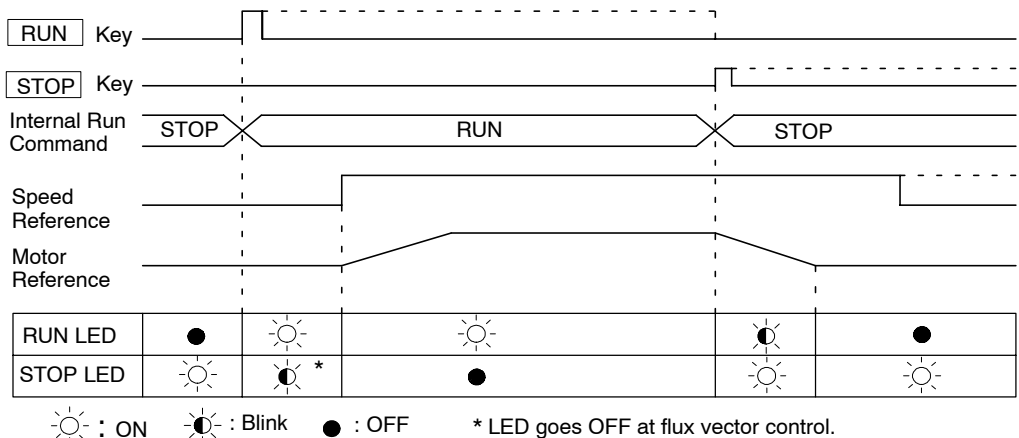

Fig. 27 Run and Stop LED Display

5.2 DIGITAL OPERATOR MODE SELECTION

This section describes the digital operator modes of the VS-686SS5.

(1) Modes

The VS-686SS5 is equipped with 3 modes as shown in the following table.

Table 20 Digital Operator Modes

Mode	Primary Functions
Drive Mode	The inverter can be run in this mode. Use this mode when monitoring values such as frequency references or output current, displaying fault information, or displaying the fault history.
Program Mode	Use this mode when setting/reading the constants required for operation. Constants of groups U, A, b, C, d, E, F, H, L, o, T can be accessed.
Modified Constants Mode	Use this mode to set/read constants that have been changed from their factory-set values.

(2) Switching Modes

Drive mode or program mode is selected by depressing [DRIVE/PRGM] key. The DRIVE LED lights when drive mode is selected, and goes OFF when program mode is selected.

Constants display and settings in each mode can be changed by depressing [Δ], [V] or [> RESET] key. Depress [DATA/ENTER] key to write-in the constants.

Modified constants mode can be accessed from drive mode by depressing [> RESET] and [DRIVE/PRGM] keys simultaneously. Depress [DRIVE/PRGM] key to return to drive mode. These are the basic operation steps.

The example below shows the operation using digital operator for each mode. Constants A1-01 (display in program mode) and E1-08 (display in modified constants mode) differ depending on user setting.

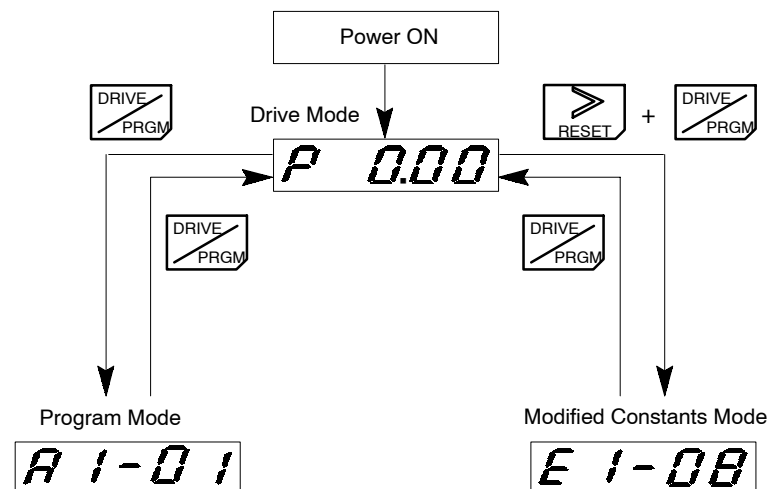

Drive mode and program mode can be changed by the digital operator even during operation. Even if the mode is changed to the program mode to set/read constants during operation, the inverter continues operation. The inverter does not operate even if the run command is input, when the program mode is selected.











When the constants are set/read during operation, depress [DRIVE/PRGM] key and then [DATA/ENTER] key to return to the speed reference value display (the same as power-ON display).

5.3 DRIVE MODE

The inverter can operate in this mode. Run data display and fault display are possible.

Each time the display selection key is depressed, the item to be monitored is changed. At an occurrence of a fault, the digital operator enters the fault display mode automatically. The display mode returns to the one selected previously by depressing [> RESET] key.

Table 21 Typical Operation in Drive Mode

Description	Key Sequence	Digital Operator Display
Power ON *1		
Speed Reference *2		
Motor Speed		
Output Current		
Output Voltage *3		
U Constants *4		

*1 The first item to be displayed after power ON can be selected from speed reference value, motor speed, output current, and display item set in o1-01 by setting an appropriate value for o1-02.

*2 A speed reference value can be set by using [Λ], [v] or [> RESET] key.

*3 Instead of the output voltage, item to be displayed from U1 constant can be selected by setting o1-01.

*4 Select the U constant to be displayed by using [Λ], [v] or [> RESET] key.









*5 The U constant selected previously is displayed.

(1) Changing Speed Reference Value

[Example]

Changing the speed reference value from 0.00% to 100.0% in the LOCAL and drive modes.

Table 22 Changing the Speed Reference Value











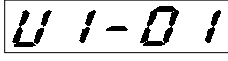

Step	Description	Key Sequence	Digital Operator Display	Remarks
①	Display the speed reference value.			
②	Change the value to "100.0%".	  		The value to be set blinks.
③	Write-in the set value.		 	Display stops blinking for 2 seconds. Display starts blinking again.

(2) Monitor Display

[Example]

Monitoring DC bus voltage (U1-07) during speed reference display.

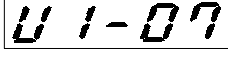
Table 23 Typical Monitor Display Operation

Step	Description	Key Sequence	Digital Operator Display	Remarks
①	Displaying the speed reference value. Display U constant.	 Depress 4 times.	 	U constant selected previously is displayed.
②	Select U1-07.	  		
③	Display monitored value.			
④	Return to constant No. display.			
⑤	Return to speed reference display.	 Depress 4 times.		

(3) Fault Display

When the VS-686SS5 detects a fault, the fault is displayed on the digital operator and activate the fault contact output and the motor coasts to a stop. Refer to Table 31 for the fault and the display at fault occurrence.

Since the VS-686SS5 stores the information obtained at fault occurrence in the inverter, the information can be verified. For details, refer to Table A-4.

[Example]

Verifying the status at fault occurrence (speed reference, motor speed, output current in the example) and resetting the fault when overcurrent occurs during operation at 50% speed.

Table 24 Typical Operation of Fault Display

Step	Description	Key Sequence	Digital Operator Display	Remarks
	Motor rotating at 50% speed.			
	Overcurrent occurs.			Displays the fault.
①	Move to program mode.			
②	Verify the speed reference at fault occurrence.			
③	Verify the value.			
④	Return to constant No. display.			
⑤	Verify the motor speed at fault occurrence.			
⑥	Verify the value.			
⑦	Return to constant No. display.			
⑧	Verify the output current at fault occurrence.			
⑨	Verify the value.			
⑩	Return to constant No. display.			
⑪	Return to drive mode.			
⑫	Reset the fault.			By resetting the fault, the display entered just prior to the fault occurrence is returned.



Fault reset cannot be activated while forward/reverse run signal from control circuit terminal is ON. Turn OFF the signal and check the safety of the surrounding area, then reset the inverter.

5.4 INITIALIZE MODE

As described below, the access level to set/read constants or control method can be selected. Set initialize mode constants before use of the VS-686SS5.

The following table shows the constants for initialize mode.

Table 25 Initialize Mode

Constant No.	Name	Description
A1-01	Access level (change enable during run)	0 : Exclusive for monitoring A1-01 can be set/read and U constants in QUICK-START level can be read. 2 : QUICK-START Constants required for quick-start operation can be set/read. 3 : BASIC Constants required for basic operation can be set/read. 4 : ADVANCED Constants required for advanced operation can be set/read.
A1-02	Control method	5 : Open loop vector 6 : Flux vector
A1-03	Initialize	Constant initialization 2220 : 2-wire sequence (Returns to the value set at the factory prior to shipment.) 3330 : 3-wire sequence
A1-04	Password 1 (for input)	For future use (Do not set because of special function.)

Constant Initialization

All the constants are returned to the initial setting by initialization. Several constants such as motor constants cannot be initialized. For details, refer to APPENDIX 4.

Table 26 Constant Initialization

Step	Description	Key Sequence	Digital Operator Display	Remarks
	Displaying speed reference			
①	Move to program mode.		Constant No. display	Displays the constant No. selected formerly.
②	Select A1-03.			
③	Display the set value.			
④	Input 2220.			
⑤	Write-in the value.			Displays for 0.5 seconds.
				Display return to 0.
⑥	Return to constant No. display.			
⑥	Return to drive mode.			Speed reference return to 0.

5.5 PROGRAM MODE

The constants of the VS-686SS5 are composed of group symbols, function numbers and serial numbers for each function item as shown below. Use [^] or [v] key to change the display of group symbol, function number or serial number and select one by [DATA/ENTER] key. For details of the constants, refer to APPENDIX 4 or Descriptive Manual for Constants.

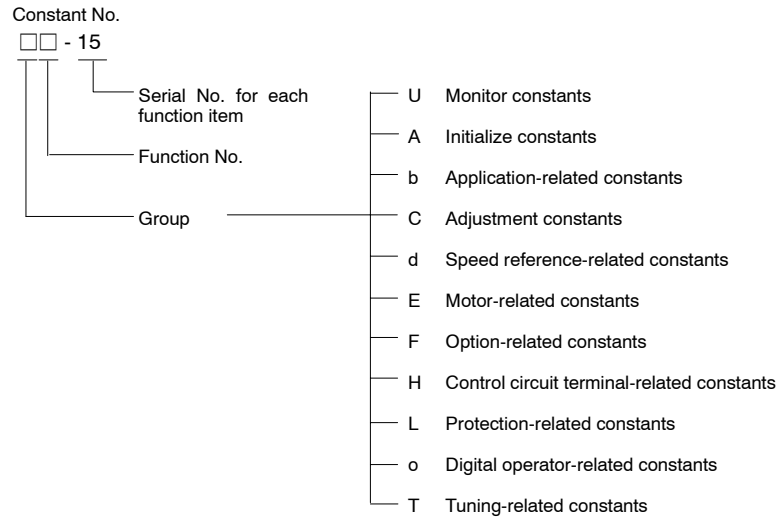

[Example]

Select BASIC or ADVANCED and change the deceleration time (C1-02) from 10.0 to 20.0 seconds.

Table 27 Changing Constant Data

Step	Description	Key Sequence	Digital Operator Display	Remarks
	Displaying speed reference			
①	Move to program mode.		Constant No. display	Displays the constant No. selected formerly.
②	Select C1-02.			
③	Display set value.			
④	Change the value.			
⑤	Write-in the value.			Displays for 0.5 seconds.
⑥	Displays the set value.			
⑦	Return to constant No. display.			Returns to display before write-in.
⑧	Return to drive mode.			















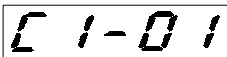









5.6 MODIFIED CONSTANTS MODE

Compares the constant values preset at the factory with the values changed by the user, and displays the constants changed from the preset constants automatically. In this mode, constants can be read; in addition, they can also be set or changed.

[Example]

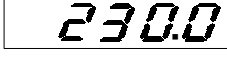
Read the constants C1-01 (acceleration time 1) and E1-01 (input voltage) when the factory settings have been changed. In addition, change the setting of E1-01 (input voltage) from 220V to 230V in this mode.

Table 28 Typical Operation in Modified Constants Mode

Step	Description	Key Sequence	Digital Operator Display	Remarks	
	Power ON				
①	Switch to REMOTE mode.		 REMOTE LED ON		
②	Select modified constants mode.	 	 DRIVE LED blinks.	Modified constants mode can be accessed from drive mode by depressing [RESET] and [DRIVE/PRGM] keys simultaneously. Verify that DRIVE LED is blinking.	
③	Verify the set value.				
④	Return to constant No. display.				
⑤	Display the next-to-be-changed constant.	 			
⑥	Verify the set value.				
⑦	Change the value.	  			
⑧	Write-in the value.				Displays for 0.5 seconds.
⑨	Displays the set value.				
⑩	Return to constant No. display.				
⑪	Return to drive mode.				

6 MAINTENANCE AND INSPECTION



WARNING

- Never touch high-voltage terminals in the inverter.
Failure to observe this warning can result in an electric shock.
- Replace all protective covers before powering up the inverter. To remove the cover, make sure to shut OFF the molded-case circuit breaker.
Failure to observe this warning can result in an electric shock.
- Perform maintenance or inspection only after verifying that the CHARGE LED goes OFF, after the main circuit power supply is turned OFF.
The capacitors are still charged and can be dangerous.
- Only authorized personnel should be permitted to perform maintenance, inspections or parts replacement.
[Remove all metal objects (watches, bracelets, etc.) before operation.]
(Use tools which are insulated against electrical shock.)
Failure to observe this warning can result in an electric shock.



CAUTION

- The control PC board employs CMOS ICs. Do not touch the CMOS elements.
They are easily damaged by static electricity.
- Do not connect or disconnect wires or connectors while power is applied to the circuit.
Failure to observe this caution can result in personal injury.

This chapter describes basic maintenance and inspection procedures for the VS-686SS5.

6.1 PERIODIC INSPECTION

The VS-686SS5 will function longer if it is kept clean, cool and dry, while observing the precautions listed in Par. 2.3. Check for tightness of electrical connections, discoloration or other signs of overheating or aging. Use Table 29 as your inspection guide. Before servicing, turn OFF AC main circuit power and be sure that the CHARGE LED is OFF.

Table 29 Periodic Inspection

Component	Check	Corrective Action
External Terminals, Unit Mounting Bolts, Connectors, etc.	Loose screws	Tighten.
	Loose connectors	Tighten.
Heatsink	Build-up of dust and dirt	Blow with dry compressed air of 39.2×10^4 to 58.8×10^4 Pa (4 to 6kg·cm ²) pressure.
Printed Circuit Board	Accumulation of conductive dust or oil.	Blow with dry compressed air of 39.2×10^4 to 58.8×10^4 Pa (4 to 6kg·cm ²) pressure. If dust and oil cannot be removed, replace the board.
Cooling Fan	For abnormal noise and vibration. Whether the cumulative operation time exceeds 20,000 hours or not.	Replace the cooling fan.
Power Elements	Accumulation of dust and dirt	Blow with dry compressed air of 39.2×10^4 to 58.8×10^4 Pa (4 to 6kg·cm ²) pressure.
Smoothing Capacitor	Discoloration or odor	Replace the capacitor or inverter unit.

6.2 PARTS REPLACEMENT SCHEDULE (GUIDELINES)

Replace the following parts periodically, for a long, safe, trouble free working life of VS-686SS5.

Table 30 Parts Replacement Schedule

Parts	Interval (Approx.)	Remarks
Cooling Fan	2 to 3 years	Replace with new one.
Smoothing Capacitor	5 years	Replace with new one. (Decided after inspection.)
Breakers or Relays	—	Decided after inspection.
Fuse	10 years	Replace with new one.
Aluminum Electrolytic Capacitor on PC Board	5 years	Replace with new one. (Decided after inspection.)

NOTE

Operating conditions are as follows:

Ambient temperature : 30°C yearly average

Load factor : 80% or below

Operation rate : 20 hours or below /day

7 TROUBLESHOOTING

This chapter describes the inverter fault display and the fault contents caused by motor/machine malfunctions and the corrective actions to be taken.

7.1 FAULT DIAGNOSIS AND CORRECTIVE ACTIONS

When the VS-686SS5 detects a fault, the fault is displayed on the digital operator and activates the fault contact output and the motor coasts to a stop. Check the cause in Table 31 and take the corrective actions. If the inspections or corrective actions described cannot solve the problem, contact your YASKAWA representative immediately.

To restart, turn ON the reset input signal or depress [>RESET] key or shut OFF the main circuit power supply once, to reset the stop status.

Table 31 Fault Diagnosis and Corrective Actions

Fault Display	Description	Details	Corrective Action	Rank*
Uu1	Main circuit undervoltage (UV1)	The main circuit DC voltage fell below the undervoltage detection level while running or decelerating and momentary power loss ride-through time elapsed. Detection level: 200 V class: Approx. 190 V or less 400 V class: Approx. 380 V or less	<ul style="list-style-type: none"> • Check the power supply wiring. • Correct the line voltage. 	A
Uu3	Pre-charge contactor open (UV3)	The pre-charge contactor opened while running or decelerating.		A
Uu	Momentary power loss (UV)	<ul style="list-style-type: none"> • The main circuit DC voltage fell below the undervoltage detection level. • The pre-charge contactor opened. 	—	C
GF	Ground fault (GF)	Inverter output grounding current exceeded 50% of inverter rated current.	<ul style="list-style-type: none"> • Check that motor insulation has not deteriorated. • Check that connection between inverter and motor is not damaged. 	A
oC	Overcurrent (OC)	The inverter output current exceeded the OC level.	<ul style="list-style-type: none"> • Check the motor coil resistance. • Extend the accel/decel time. • Check the motor insulation. • Multi-meter check 	A
ou	Overvoltage (OV)	The main circuit DC voltage exceeded the OV level. Detection level: 200 V class: Approx. 406 V 400 V class: Approx. 812 V	<ul style="list-style-type: none"> • Extend the deceleration time. • Add braking circuit. 	A (C during stop)
oS	Overspeed (OS)	The motor speed exceeded the overspeed level (F1-08). Detection time: F1-09 The inverter operates according to the setting of constant <u>F1-03</u> .	Check the load.	B
dEv	Speed deviation (dEV)	The deviation of the speed reference and speed feedback exceeded the regulation level (F1-10). Detection time: F1-11 The inverter operates according to the setting of constant <u>F1-04</u> .	Check the load.	B

(Cont'd)

Table 31 Fault Diagnosis and Corrective Actions (Cont'd)

Fault Display	Description	Details	Corrective Action	Rank*
ZdEV ^{*2}	Phase Z pulse fault (ZdEV)	<ul style="list-style-type: none"> Excessive speed deviation caused by phase Z error detection Malfunction caused by phase Z pulse error or noise 	<ul style="list-style-type: none"> Check the PG wiring cable and connector. Readjust the zero-pulse. 	A
StO	Step out (STO)	Control is disabled by step out.	<ul style="list-style-type: none"> Check the motor constants. (Refer to page 44.) Set the constant induced voltage (E1-13) to a value that is 10% less than that of Ke on the nameplate. Check the operating temperature of the motor. Decrease ASR gain (C5-01). Decrease accel time (C1-01). 	A
PGO	PG open circuit (PGO)	The PG line is broken. Detection time: F1-13 The inverter operates according to the setting of constant <u>F1-02</u> .	<ul style="list-style-type: none"> Check the PG line. Check the condition of the motor lock or the load. 	B
PF	Excessive ripple in DC bus bar voltage (PF)	<ul style="list-style-type: none"> Inverter input voltage has open-phase. Large unbalance in input voltage. 	<ul style="list-style-type: none"> Check the line voltage. Re-tighten the input terminal screws. 	A
LF	Load open-phase (LF)	Inverter output has open-phase. ^{*3}	<ul style="list-style-type: none"> Check the output wiring. Check the motor impedance. Re-tighten the input terminal screws. 	A
LF2 ^{*4}	Output current unbalance (LF2)	A large unbalance occurred in the output current because of one of the following causes. <ul style="list-style-type: none"> The inverter output wiring is faulty. ASR gain setting is incorrect. Failure occurred with parts on the output side of the inverter. Motor is faulty. (Unbalanced impedance in motor) 	<ul style="list-style-type: none"> Check the output wiring. Re-tighten the input terminal screws. Check the disconnection of the motor coil. Decrease ASR proportional (p) gain 1 (C5-01). Replace the inverter.*5 Replace the motor.*5 	A
SC	Load short-circuit (SC)	Inverter output (load) is short-circuited.	<ul style="list-style-type: none"> Check the motor coil resistance. Check the motor insulation. 	A
PUF	Fuse blown (PUF)	<ul style="list-style-type: none"> Main transistor was broken. DC circuit fuse was blown. 	Check for damaged transistor, load side short-circuit, grounding, etc.	A
OH	Inverter overheat alarm (OH)	The transistor heatsink temperature exceeded the allowable value (95°C). The inverter operates according to the setting of constant <u>L8-03</u> .	<ul style="list-style-type: none"> Check the heatsink and the ambient temperature. Check the filter and the fan. 	B
OH1	Inverter overheat (OH1)	The transistor heatsink temperature exceeded the allowable value (105°C).		A
OL1	Motor overload (OL1)	Inverter output exceeded the motor overload level.	Reduce the load.	A
OL2	Inverter overload (OL2)	Inverter output exceeded the inverter overload level.	<ul style="list-style-type: none"> Reduce the load. Extend the acceleration time. 	A
OL3	Overtorque detection 1 (OL3)	Torque exceeded overtorque detection level 1 (L6-02). Detection time: L6-03 The inverter operates according to the setting of constant <u>L6-01</u> .	Check the load.	B
OL4	Overtorque detection 2 (OL4)	Torque exceeded overtorque detection level 2 (L6-05). Detection time: L6-06 The inverter operates according to the setting of constant <u>L6-04</u> .		B
RR	Braking transistor fault (RR)	The braking transistor has failed.	Replace the inverter.	A

(Cont'd)

Table 31 Fault Diagnosis and Corrective Actions (Cont'd)

Fault Display	Description	Details	Corrective Action	Rank*
<i>rH</i>	Braking resistor unit overheat (RH)	The braking resistor unit temperature has exceeded the allowable value. (Protects only inverter built-in type)	Reduce the regenerative load.	A
<i>bUS</i>	Transmission fault with transmission option (bUS)	Transmission fault with transmission option (detected when the fault continued for 2.5 seconds)	Check the transmission devices and the transmission signals.	A
<i>EF0</i>	External fault from transmission option (EF0)	External fault was input from the transmission option.	External fault, defined by user specification, was input from the transmission option. Find the external fault items from the I/O list and correct it.	B
<i>EF3</i>	External fault at terminal 3 (EF3)	Fault occurred in the external control circuit. The inverter operates according to the settings of constants H1-01 to H1-06.	Check the condition of the input terminal. If the fault is displayed when terminal is not connected, replace the inverter.	B
<i>EF4</i>	External fault at terminal 4 (EF4)			B
<i>EF5</i>	External fault at terminal 5 (EF5)			B
<i>EF6</i>	External fault at terminal 6 (EF6)			B
<i>EF7</i>	External fault at terminal 7 (EF7)			B
<i>EF8</i>	External fault at terminal 8 (EF8)			B
<i>CPF00</i>	Control circuit fault 1 (CPF00) (Digital operator transmission fault)	<ul style="list-style-type: none"> Transmission between the inverter and digital operator cannot be established 5 seconds after supplying power. MPU peripheral element check fault (initial) 	<ul style="list-style-type: none"> Insert the digital operator connector again. Check the control circuit wiring. Replace the control card. 	A
<i>CPF01</i>	Control circuit fault 2 (CPF01) (Digital operator transmission fault)	<ul style="list-style-type: none"> Transmission between the inverter and digital operator is established once after supplying power, but later transmission fault continues for more than 2 seconds. MPU peripheral element check fault (initial) 	<ul style="list-style-type: none"> Check the control circuit wiring. Replace the control card. 	A
<i>CPF02</i>	Baseblock circuit fault (CPF02)	Inverter control unit fault.	Replace the control card.	A
<i>CPF03</i>	EEPROM fault (CPF03)			A
<i>CPF04</i>	CPU internal A/D converter fault (CPF04)			A
<i>CPF05</i>	CPU external A/D converter fault (CPF05)			A
<i>CPF06</i>	Option card connection fault (CPF06)	The option card is not installed correctly.	Install the option card again.	A
<i>CPF20</i>	A/D converter fault in option card (CPF20)	Option card (AI-14B/U) A/D converter fault	<ul style="list-style-type: none"> Check the option card contact part. Replace the option card. 	A
<i>CPF23</i>	Cross-diagnose fault between transmission option and control card (CPF23)	Diagnosis data has not been updated for more than 0.2 seconds between the transmission option and the control card.	<ul style="list-style-type: none"> Check the transmission option contact part. Replace the transmission option. 	A
<i>Err</i>	EEPROM writing fault (Err)	EEPROM internal data did not match when initializing the constant.	Replace the control card.	A
<i>oPE01</i>	kVA selection fault (OPE01)	kVA selection fault	Check and set the constant data.	D
<i>oPE02</i>	Constant setting range fault (OPE02)	Constant data is out of range.	Check the constant data settings.	D
<i>oPE03</i>	Multi-function contact input selection fault (OPE03)	The same values are set except for F and FF.	Check the function selection.	D

(Cont'd)

Table 31 Fault Diagnosis and Corrective Actions (Cont'd)

Fault Display	Description	Details	Corrective Action	Rank*
<i>oPE05</i>	Option reference selection fault (OPE05)	<ul style="list-style-type: none"> • C-option is not connected although run command from C-option is selected. • C-option is not connected although frequency reference from C-option is selected. 	<ul style="list-style-type: none"> • Check and set the constant data. • Connect the C-option. 	D
<i>oPE06</i>	Control method selection fault (OPE06)	PG control card is not connected during flux vector control.	Connect PG control card.	D
<i>oPE07</i>	Multi-function analog input selection fault (OPE07)	C-option is AI-14B and option/inverter change is selected.	Check and set the constant data.	D
<i>oPE08</i>	Multi-function input/output selection fault (OPE08)	Any of the following setting faults has occurred: <ul style="list-style-type: none"> • The setting unused in the control method is selected for F4-01 and F4-04. • The setting unused in the control method is selected for F5-01 and F5-02. • The setting unused in the control method is selected for H1-01 to H1-06. • The setting unused in the control method is selected for H2-01 to H2-03. • The setting unused in the control method is selected for H3-05 and H3-09. • The setting unused in the control method is selected for H4-01 and H4-04. • The setting unused in the control method is selected for o1-01. 	Check and set the constant data.	D
<i>oPE 10</i>	R/min setting fault (OPE10)	The settings of E1-06 to E1-08 do not satisfy the following conditions: $E1-06 \geq E1-07 \geq E1-08$	Check and set the constant data.	D
<i>oPE 12</i>	Energy-saving control constants setting fault	Energy-saving control constant values are out of range.	Check the motor nameplate values and inverter constants (E-constants) settings.	D
<i>oPr</i>	Digital operator fault (OPr)	The digital operator was disconnected during operation by run command from the digital operator.	<ul style="list-style-type: none"> • Check the wiring cable and the digital operator connection. • Replace the control card. 	A

*1: The ranks are classified as follows:

- A : Major fault (Motor coasts to a stop, digital operator indicator lights, and fault contact is output.)
- B : According to the constants for major/minor fault selection (constants underlined in the table), major fault (Motor coasts to a stop or decelerates to a stop, digital operator indicator lights, and fault contact is output.) or minor fault (Rank C) can be selected.
- C : Minor fault [Operation continues, digital operator indicator blinks, no fault contact is output, and minor fault contact is output (when multi-function output is selected)].
- D : Warning (Operation cannot be performed, digital operator indicator lights, no fault contact is output, no minor fault contact is output.)

*2: ***dEu*** is displayed for the fault trace (U2 constant) and fault record (U3 constant).

*3: A load of 30% or less may result in incorrect detection of the load.

*4: The display is applicable for software No. 1033 or later (FLASH side). To check which version is being used, refer to U1-14.

*5: If replacing the motor, contact your YASKAWA representative.

7.2 MOTOR FAULTS AND CORRECTIVE ACTIONS

If any of the following faults occurs in the motor, check the cause and provide the relevant corrective action. If these inspections and corrective actions cannot solve the problem, contact your YASKAWA representative immediately.

Table 32 Motor Faults and Corrective Actions

Fault	Check Point	Corrective Action
Motor does not rotate.	Power supply voltage applied to power supply terminals R, S, T?	<ul style="list-style-type: none"> · Turn ON power supply. · Turn OFF power supply, and then ON again. · Check power supply voltage. · Make sure terminal screws are tight.
	Use rectifier type voltmeter to test. Voltage output to output terminals U, V, W correct?	Turn OFF power supply, then turn ON again.
	Motor locks due to excessive load?	Reduce the load and release the lock.
	Fault displayed in digital operator display?	Check Table 29.
	FWD or REV run command entered? (only for REMOTE operation)	Check the wiring.
	Speed setting voltage entered? (Only for REMOTE operation)	<ul style="list-style-type: none"> · Correct the wiring. · Check speed setting voltage.
	Speed reference selection (b1-01), run command selection (b1-02) correct?	Input the correct set value.
Motor rotation reverses.	Wiring of terminals U, V, W correct?	Match wiring to the phase order of the motor leads U, V, W.
	FWD and REV run signal wirings correct?	Correct the wiring.
Motor rotates, but variable speed not available.	Wiring of speed setting circuit correct?	Correct the control circuit wiring.
	Load excessively large?	Reduce the load.
Motor speed too high or too low.	Motor ratings (number of poles, voltage) correct?	Check motor nameplate specifications.
	Accel/decel speed change ratio for gears, etc. correct?	Check speed changer (gears, etc.)
	Torque reference saturated?	Check the settings of U1-09 and L7-01 to L7-04.
	Maximum speed set value correct?	Check the maximum speed set value (E1-06).
Motor speed not stable during operation.	Load excessively large?	Reduce the load.
	Load variation excessively large?	<ul style="list-style-type: none"> · Reduce the load variation. · Increase inverter and motor capacity.
	Power supply open-phase?	Check the wiring.
Motor does not rotate when the power supply is turned ON with the operation command entered.	After switching between LOCAL/REMOTE, the setting of (b1-06) correct?	Set b1-06=1.

APPENDIX 1 SPECIFICATIONS

Table A-1 Variable Torque Series Specifications

Motor	Model		SSR1-		
	Mounting Method		Foot-mounted type, flange-mounted type		
	Enclosure		Totally-enclosed fan-cooled type (IP44)		
	Rated min ⁻¹		1750 min ⁻¹	1450 min ⁻¹	1150 min ⁻¹
	Output Range	200V class	0.4 to 75 kW	0.4 to 55 kW	0.4 to 45 kW
		400V class			
	Speed Control Range (Continuous)		1:10 (Variable torque) (Refer to * for constant output range.)		
	Time Rating		Continuous		
	Insulation Class		Class F		
	Sensor		Without PG		
Inverter	Power Supply	Input Voltage	200V class: 200/208/220V 50Hz, 200/208/220/230V 60Hz 400V class: 400/415/440/460V 50/60Hz		
		Allowable Voltage Fluctuation	+10% to -15%		
		Allowable Frequency Fluctuation	± 5%		
	Control Characteristics	Control Method	Open loop vector		
		Starting Torque	50%		
		Speed Control Range	1:10		
		Speed Control Accuracy	± 0.2%		
		Torque Limit	Provided		
		Torque Accuracy	± 10%		
		Run Speed Resolution	Digital command: 0.01%		
			Analog command: 0.05% (11 bit + code)		
		Overload Capacity	150% of rated output current for one minute		
		Run Speed Setting Signal	-10 to 10V, 0 to 10V, 4 to 20mA		
		Accel/decel Time	0 to 6000 seconds		
	Main Functions	PID control, overtorque detection, torque limit, multi-step speed operation, accel/decel time change, 3-wire sequence, auto-tuning			
	Protective Functions	Motor Overload Protection	Protected by electronic thermal overload relay		
		Instantaneous Overcurrent	Motor coasts to a stop at approx. 200% of inverter rated current.		
		Blown Fuse Protection	Motor coasts to a stop by blown-fuse.		
		Overload	Motor coasts to a stop after one minute at 150% of rated output current.		
		Overvoltage	200V class: Motor coasts to a stop if main-circuit voltage exceeds 406V. 400V class: Motor coasts to a stop if main-circuit voltage exceeds 812V.		
		Undervoltage	200V class: Motor coasts to a stop if main-circuit voltage drops to 190V or below. 400V class: Motor coasts to a stop if main-circuit voltage drops to 380V or below.		
		Heatsink Overheat	Protected by thermistor		
		Stall Prevention (Overvoltage Prevention)	Stall prevention during deceleration		
		Ground Fault	Protected by electronic circuit		
	Power Charge Indication	Charge LED stays ON until bus voltage drops below 50V.			
	Environment	Location	Indoor (protected from corrosive gases and dust)		
		Humidity	90% RH or less (non-condensing)		
Storage Temperature		-20°C to +60°C			
Ambient Temperature		-10°C to +40°C (Enclosed wall-mounted type), -10°C to +45°C (Open chassis type)			
Elevation		1000 m or less			
Vibration	9.8 m/s ² (1G) at 10 to less than 20 Hz, up to 2 m/s ² (0.2G) at 20 to 50 Hz				

*Constant output range is as follows:

1750 min ⁻¹	1450 min ⁻¹	1150 min ⁻¹
1:1.5 (0.4 to 75 kW) 1:1.3 (90 to 160 kW)	1:1.5 (0.4 to 55 kW) 1:1.3 (75 to 160 kW)	1:1.5 (0.4 to 45 kW) 1:1.3 (55 to 160 kW)

Note: Variable torque series cannot be used to the following applications:

- Commercial power supply / inverter power supply switch operation
- One inverter drives several motors (multi-motor drive).
- Start during motor run

Table A-2 Constant Torque Series Specifications

Motor	Model		SST4-		
	Mounting Method		Foot-mounted type, flange-mounted type		
	Enclosure		Totally-enclosed type, totally-enclosed externally-cooled type (IP44)		
	Rated min ⁻¹		1750 min ⁻¹	1450 min ⁻¹	1150 min ⁻¹
	Output Range	200V class	0.4 to 75 kW	0.4 to 75 kW	0.4 to 75 kW
		400V class	0.4 to 300 kW	0.4 to 250 kW	0.4 to 200 kW
	Speed Control Range (Continuous)		1:500 (Constant torque) (Refer to * for constant output range.)		
	Time Rating		Continuous		
	Insulation Class		Class F		
	Sensor		With PG		
Inverter	Power Supply	Input Voltage	200V class: 200/208/220V 50Hz, 200/208/220/230V 60Hz 400V class: 400/415/440/460V 50/60Hz		
		Allowable Voltage Fluctuation	+10% to -15%		
		Allowable Frequency Fluctuation	± 5%		
	Control Characteristics	Control Method	Flux vector		
		Starting Torque	150%		
		Speed Control Range	1:500		
		Speed Control Accuracy	± 0.02%		
		Torque Limit	Provided		
		Torque Accuracy	± 5%		
		Run Speed Resolution	Digital command: 0.01%		
			Analog command: 0.05% (11 bit + code)		
		Overload Capacity	150% of rated output current for one minute		
		Run Speed Setting Signal	-10 to 10V, 0 to 10V, 4 to 20mA		
	Accel/decel Time	0 to 6000 seconds			
	Main Functions	PID control, overtorque detection, torque limit, multi-step speed operation, accel/decel time change, 3-wire sequence, speed control/torque control change auto-tuning			
	Protective Functions	Motor Overload Protection	Protected by electronic thermal overload relay		
		Instantaneous Overcurrent	Motor coasts to a stop at approx. 200% of inverter rated current.		
		Blown Fuse Protection	Motor coasts to a stop by blown-fuse.		
		Overload	Motor coasts to a stop after one minute at 150% of rated output current.		
		Overvoltage	200V class: Motor coasts to a stop if main-circuit voltage exceeds 406V. 400V class: Motor coasts to a stop if main-circuit voltage exceeds 812V.		
		Undervoltage	200V class: Motor coasts to a stop if main-circuit voltage drops to 190V or below. 400V class: Motor coasts to a stop if main-circuit voltage drops to 380V or below.		
		Heatsink Overheat	Protected by thermistor		
		Stall Prevention (Overvoltage Prevention)	Stall prevention during deceleration		
		Ground Fault	Protected by electronic circuit		
	Power Charge Indication	Charge LED stays ON until bus voltage drops below 50V.			
	Environment	Location	Indoor (protected from corrosive gases and dust)		
		Humidity	90% RH or less (non-condensing)		
Storage Temperature		-20°C to +60°C			
Ambient Temperature		-10°C to +40°C (Enclosed wall-mounted type), -10°C to +45°C (Open chassis type)			
Elevation		1000 m or less			
Vibration		9.8 m/s ² (1G) at 10 to less than 20 Hz, up to 2 m/s ² (0.2G) at 20 to 50 Hz			

*Constant output range is as follows:

1750 min ⁻¹	1450 min ⁻¹	1150 min ⁻¹
1:1.5 (0.4 to 75 kW)	1:1.5 (0.4 to 55 kW)	1:1.5 (0.4 to 45 kW)
1:1.3 (90 to 160 kW)	1:1.3 (75 to 160 kW)	1:1.3 (55 to 160 kW)
1:1.2 (200 to 300 kW)	1:1.2 (200 to 250 kW)	1:1.2 (200 kW)

Note: Constant torque series cannot be used to the following applications:

- Commercial power supply / inverter power supply switch operation
- One inverter drives several motors (multi-motor drive).

APPENDIX 2 DIMENSIONS (mm)

200 V/400 V Class Inverters of 15 kW and Lower

The following diagram shows a 200 V class, 1.5 kW inverter. Remove the top and bottom covers when mounting 200 V/400 V class inverters of 15 kW or lower in an enclosure.

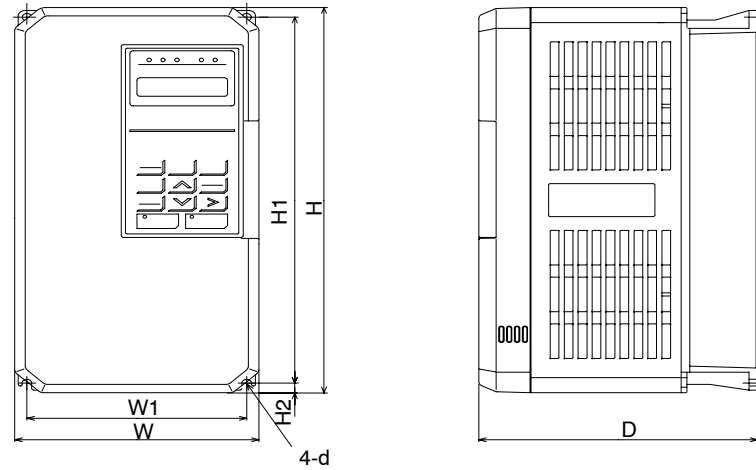

200 V/400 V Class Inverters of 18.5 kW and Higher

The following diagram shows a 200 V class, 18.5 kW inverter.

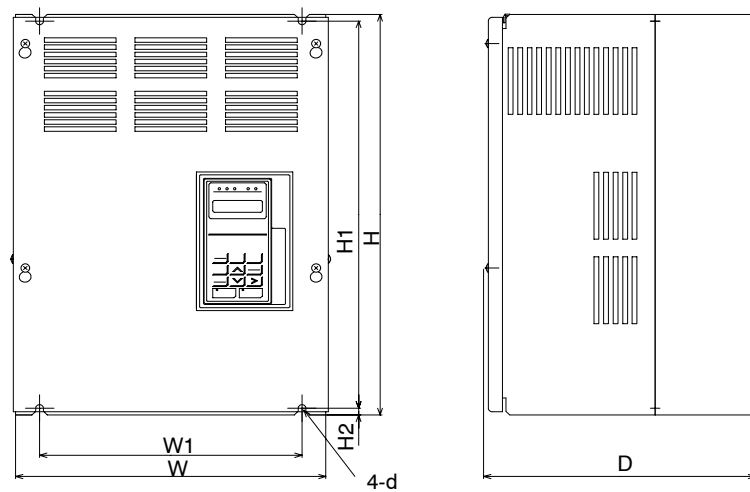

Mounting Dimensions for 400 V Class Inverters of 220 to 300 kW

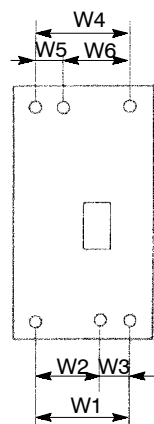

Max. Applicable Motor Output [kW]	W1	W2	W3	W4	W5	W6
220	750	440	310	850	285	565
300	750	440	310	873	298	575

Table A-3 VS-686SS5 Dimensions (mm) and Approx. Mass (kg)

Voltage Class	Max. Applicable Motor Output [kW]	Open Chassis Type (IP00)							Enclosed Wall-mounted Type (NEMA1)							DC Reactor *1	
		W	H	D	W1	H1	H2	Approx. Mass	W	H	D	W1	H1	H2	Approx. Mass		Mounting Holes d *1
200V Class	0.4	140	280	160	126	266	7.0	3	140	280	160	126	266	7.0	3	M5	Option
	0.75																
	1.5																
	2.2	140	280	180	126	266	7.0	4.5	140	280	180	126	266	7.0	4.5	M5	
	3.7																
	5.5	200	300	205	186	285	8.0	5.5	200	300	205	186	285	8.0	5.5	M6	
	7.5							6							6		
	11	250	380	225	236	365	7.5	11	250	380	225	236	365	7.5	11	M6	
	15									400				27.5			
	18.5	325	450	285	275	435	7.5	28	330	610	285	275	435	87.5	32	M6	
	22									675				152.5			
	30	425	675	350	320	650	12.5	61	430	985	350	320	650	212.5	67	M10	
37	62							68									
45	475	800	350	370	775	12.5	80	480	1110	350	370	775	212.5	87	M10		
55																	
75	575	925	400	445	895	15.0	135	580	1290	400	445	895	270	145	M12		
400V Class	0.4	140	280	160	126	266	7.0	3	140	280	160	126	266	7.0	3	M5	Option
	0.75																
	1.5	140	280	180	126	266	7.0	4	140	280	180	126	266	7.0	4	M5	
	2.2							4.5							4.5		
	3.7																
	5.5	200	300	205	186	285	8.0	6	200	300	205	186	285	8.0	6	M6	
	7.5																
	11	250	380	225	236	365	7.5	11	250	380	225	236	365	7.5	11	M6	
	15																
	18.5	325	450	285	275	435	7.5	29	330	610	285	275	435	87.5	32	M6	
	22							31							34		
	30	325	625	285	275	610	7.5	44	330	785	285	275	610	87.5	48	M6	
	37									850				152.5			
	45																
55	455	820	350	350	795	12.5	81	460	1130	350	350	795	212.5	87	M10		
75							82							88			
110	575	925	375	445	895	15.0	135	580	1290	375	445	895	270	145	M12		
160			400				145			155							
220	950	1450	435	*2	1400	25	360	—							M12	—	
300	960	1600	455	*2	1550	25	420	—							M12	—	

*1 Same for open chassis type and enclosed wall-mounted type.

*2 See page 70 for mounting dimensions.

Note: An attachment is required to mount the cooling fins (in section) on the outside of the enclosure for 200V/400V class inverters of 1.5kW or less. Contact your YASKAWA representative for details. Dimensional drawings for models with externally mounted cooling fins and other special requirements are also available from your YASKAWA representative.

APPENDIX 3 TYPICAL CONNECTION DIAGRAM

3.1 BRAKING RESISTOR UNIT

For Model CIMR-SSA20P4 to -SSA27P5 (200 V Class 0.4 to 7.5 kW),
Models CIMR-SSA40P4 to -SSA4015 (400 V Class 0.4 to 15 kW)

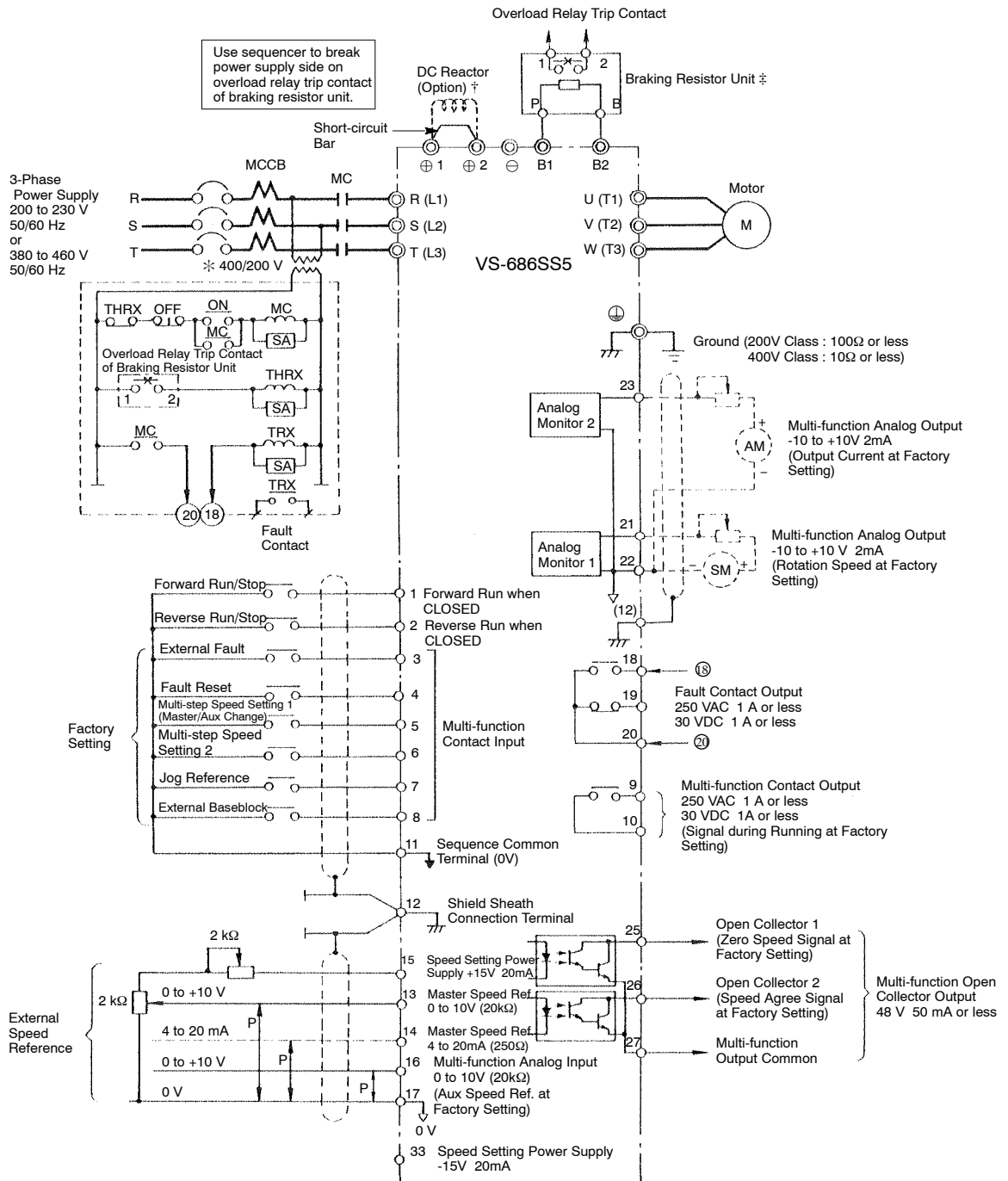

* The transformer is not necessary for 200V class.

† When installing a DC reactor (option), remove the common bar between ⊕1 and ⊕2 terminals (provided as standard) and connect a DC reactor with the terminals.

‡ When using the braking resistor unit, set constant L3-01 to "0" (overvoltage prevention selection is disabled). If it is not changed, the inverter may not stop within set decel time.

3.2 BRAKING UNIT AND BRAKING RESISTOR UNIT

For models CIMR-SSA2011, -SSA2015 (200 V Class 11, 15 kW)

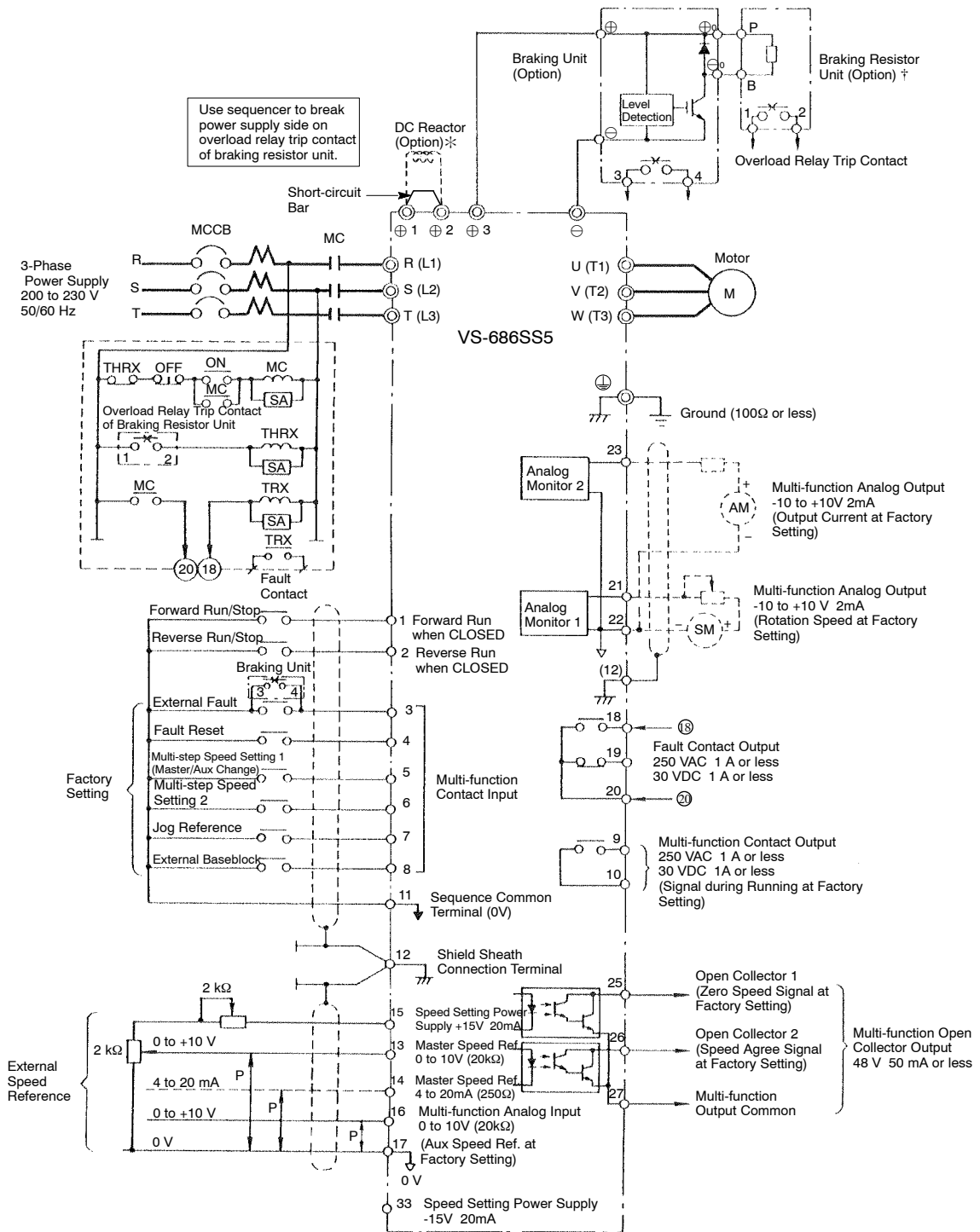

※ When installing a DC reactor (option), remove the common bar between ⊕1 and ⊕2 terminals (provided as standard) and connect a DC reactor with the terminals.

† When using the braking resistor unit, set constant L3-01 to "0" (overvoltage prevention selection is disabled). If it is not changed, the inverter may not stop within set decel time.

For models CIMR-SSA2018, -SSA2022 (200 V Class 18.5, 22 kW)

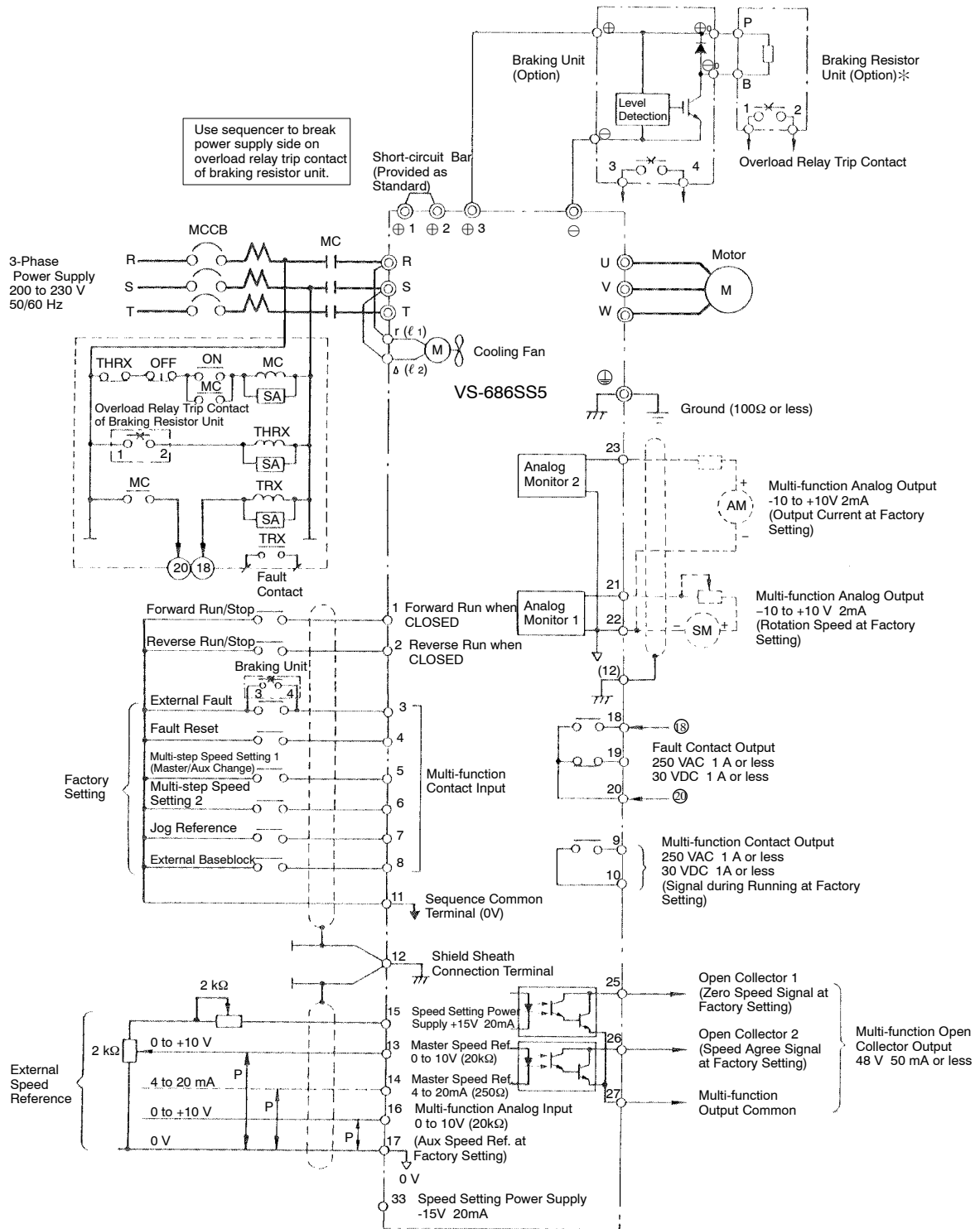

* When using the braking resistor unit, set constant L3-01 to "0" (overvoltage prevention selection disabled). If it is not changed, the inverter may not stop within set decel time.

3.3 THREE BRAKING UNITS IN PARALLEL

For Models CIMR-SSA2030 to -SSA2075 (200 V Class 30 to 75 kW)

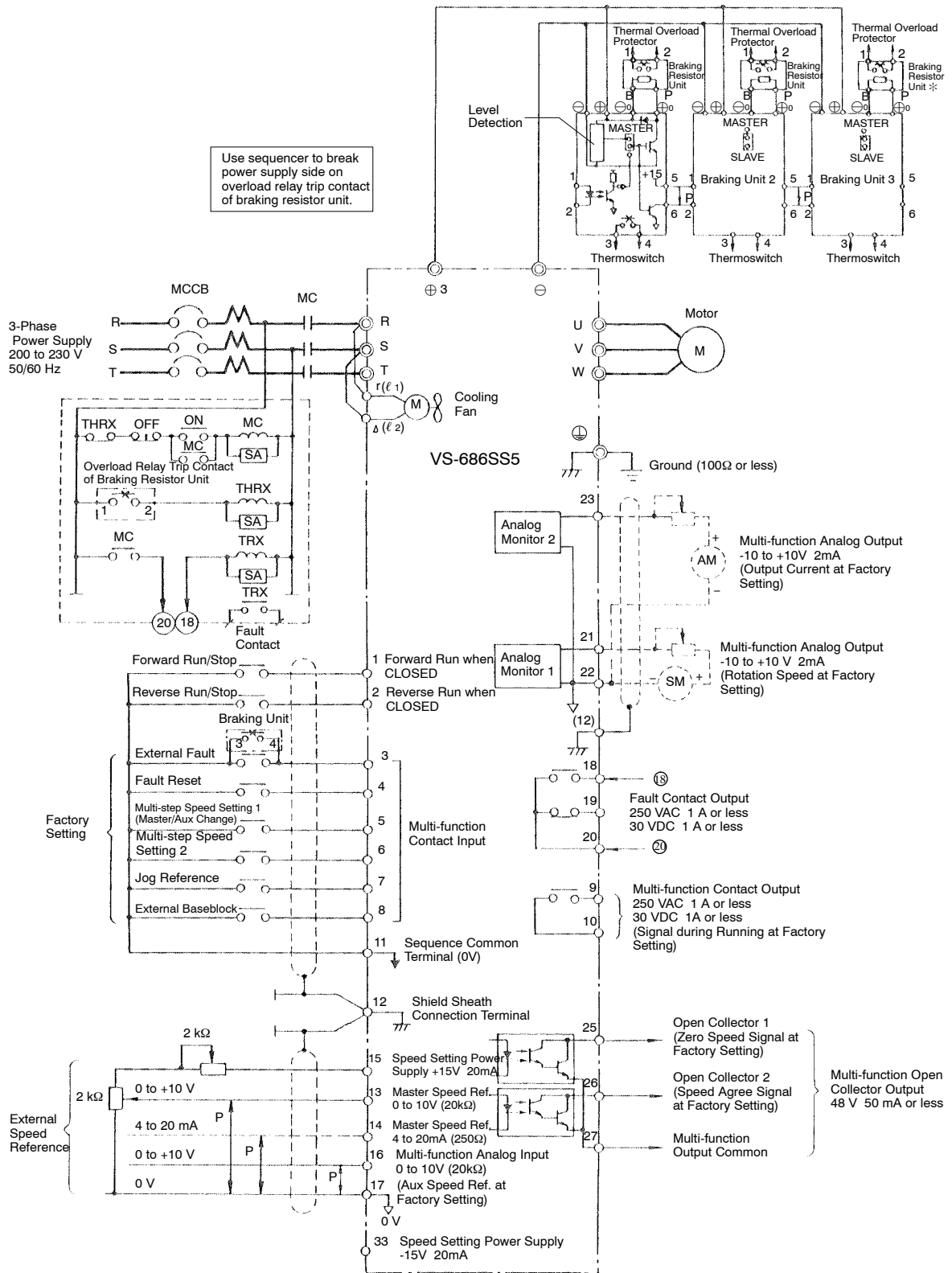

* When using the braking resistor unit, set constant L3-01 to "0" (overvoltage prevention selection disabled). If it is not changed, the inverter may not stop within set decel time.

For Models CIMR-SSA4055 to -SSA4160 (400V Class 55 to 160 kW)

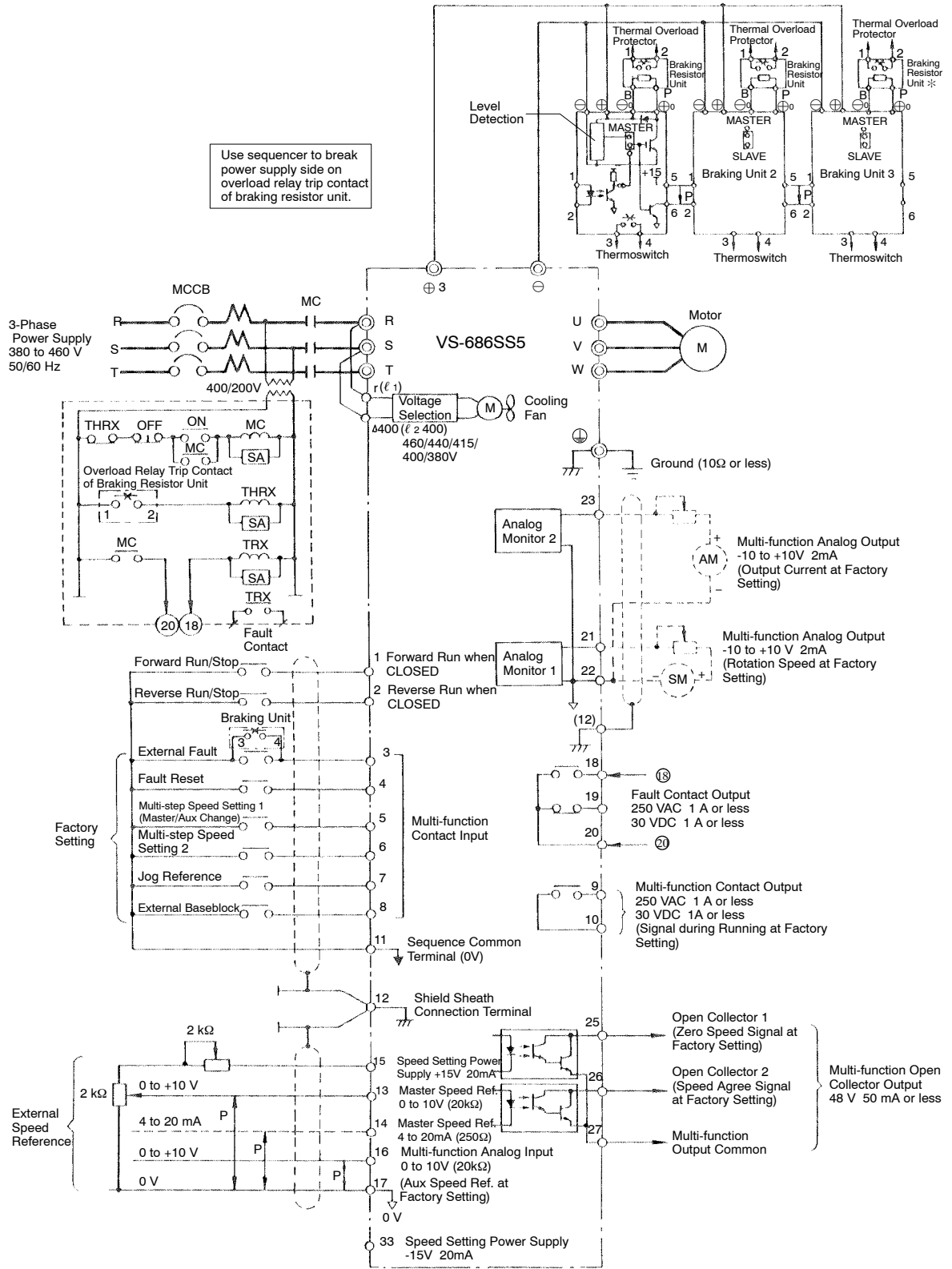

* When using the braking resistor unit, set constant L3-01 to "0" (overvoltage prevention selection disabled). If it is not changed, the inverter may not stop within set decel time.

For Models CIMR-SSA4220 to -SSA4300 (400V Class 220 to 300 kW)

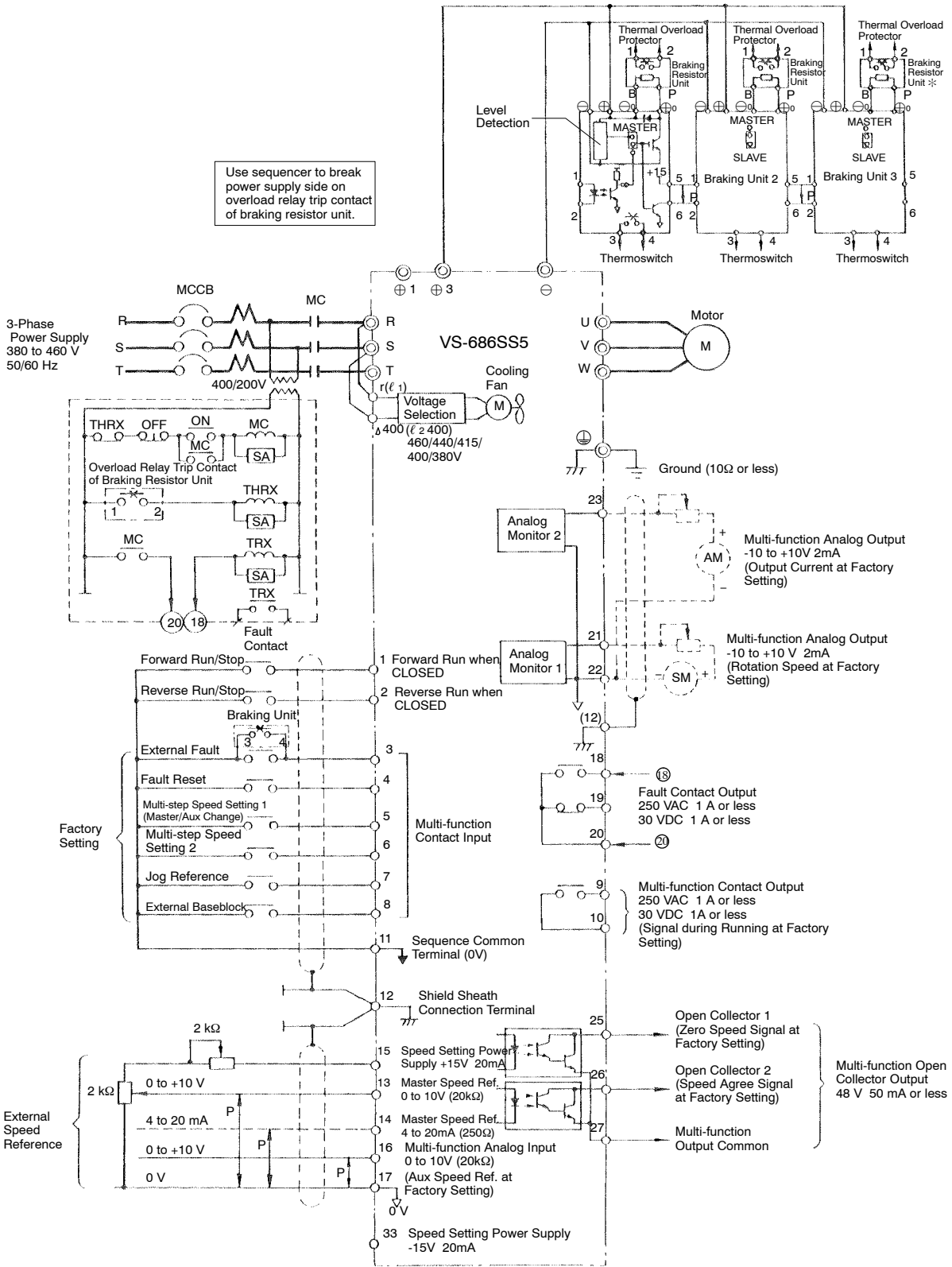

* When using the braking resistor unit, set constant L3-01 to "0" (overvoltage prevention selection disabled). If it is not changed, the inverter may not stop within set decel time.

3.4 WITH CONTACT OUTPUT, OPEN COLLECTOR OUTPUT

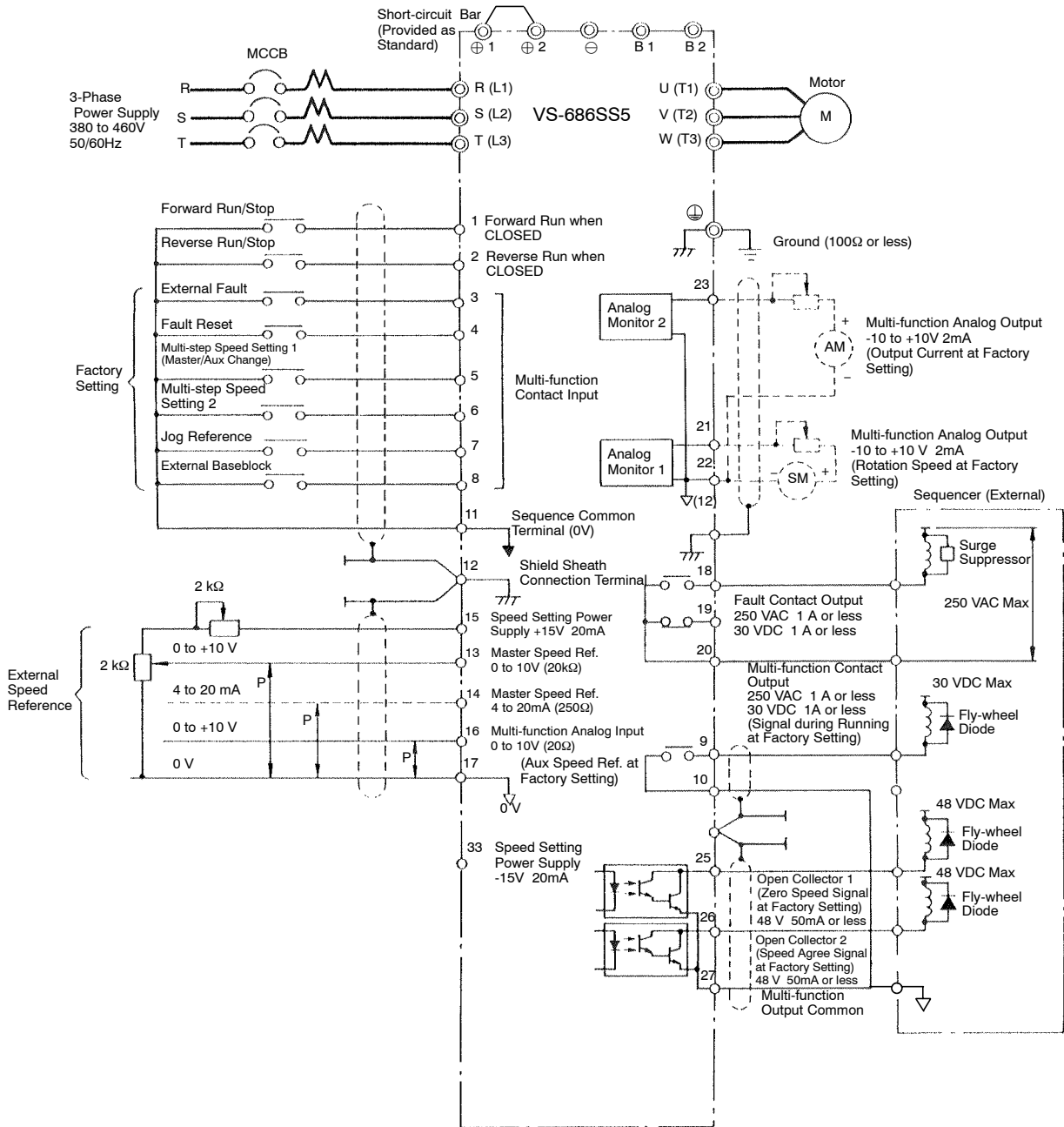

Note: Main circuit terminals are indicated by 200V 7.5kW / 400V 15kW models or below.

APPENDIX 4 CONSTANTS LIST

The numbers of constants displayed in the digital operator depend on the setting of constant access level (A1-01). For details, refer to Descriptive Manual for Constants.

Table A-4 Monitor Item List

	Constant No.	Name	Unit	Control Method (○ = Monitor enabled, x = Monitor disabled) *1	
				Open loop vector	Flux vector
Monitor	U1-01	Speed reference	0.01% *2	○	○
	U1-02	Output frequency	0.01Hz	○	○
	U1-03	Output current	0.1A *3	○	○
	U1-04	Control method	[No.]	○	○
	U1-05	Motor speed	0.01% *2	○	○
	U1-06	Output voltage reference	0.1V	○	○
	U1-07	DC bus voltage	1V	○	○
	U1-08	Output power	0.1kW	○	○
	U1-09	Torque reference (internal)	0.1%	○	○
	U1-10	Input terminal status	[Bit]	○	○
	U1-11	Output terminal status	[Bit]	○	○
	U1-12	Operation status	[Bit]	○	○
	U1-13	Cumulative operation time	1H	○	○
	U1-14	Software No. (at FLASH side)	[No.]	○	○
	U1-15	Control circuit terminal 13 input voltage	0.1%	○	○
	U1-16	Control circuit terminal 14 input current/voltage	0.1%	○	○
	U1-17	Control circuit terminal 16 input voltage	0.1%	○	○
	U1-18	Motor q-axis current (Iq)	0.1%	○	○
	U1-19	Motor d-axis current (Id)	0.1%	○	○
	U1-20	Speed reference after soft-start	0.01% *2	○	○
	U1-21	ASR input (speed deviation)	0.01%	○	○
	U1-22	ASR output	0.01%	○	○
	U1-27	q-axis current reference	0.1%	○	○
	U1-28	d-axis current reference	0.1%	○	○
	U1-29	Voltage limit control output	0.1%	○	○
	U1-30	q-axis current control output	0.1%	○	○
	U1-31	d-axis current control output	0.1%	○	○
	U1-32	Output voltage reference Vq	0.1V	○	○
	U1-33	Output voltage reference Vd	0.1V	○	○
	U1-36	Output voltage phase	0.1deg	○	○
	U1-37	Magnetic-pole position detection value (with PG)	0.1deg	x	○
	U1-38	Magnetic-pole position detection estimated value (without PG)	0.1deg	○	x
	U1-41	LED check (diagnosis)	—	○	○
	U1-42	Operation status 2	[Bit]	○	○
U1-43	Command 1 from transmission option	[Bit]	○	○	
U1-44	Command 2 from transmission option	[Bit]	○	○	
U1-45	External torque reference	0.01%	○	○	
U1-46	Torque compensation	0.01%	x	○	
U1-47	DO-08/H output status	[Bit]	○	○	
U1-48	Momentary power loss drop amount	0.01%	○	○	
U1-49	Software No. (at CPU side)	[No.]	○	○	
U1-50	Speed detection PG counter value	Pulse	x	○	
U1-51	Output current phase	0.1deg	○	○	
U1-53	PID feedback amount	0.01%	○	○	
U1-54	DI-16H input status	[BCD]	○	○	

*1 Even if ○ is indicated, some constants are not displayed depending on access level.

*2 The unit varies depending on the setting of o1-03.

*3 0.01A for models of 7.5 kW or below.

Table A-4 Monitor Item List (Cont'd)

	Constant No.	Name	Unit	Control Method (○ = Monitor enabled, x = Monitor disabled) *1	
				Open loop vector	Flux vector
Fault Trace	U2-01	Current fault	[Error display]	○	○
	U2-02	Last fault	[Error display]	○	○
	U2-03	Speed reference at fault (U1-01)	0.01%	○	○
	U2-04	Output frequency at fault (U1-02)	0.01Hz	○	○
	U2-05	Inverter output current at fault (U1-03)	0.1A *2	○	○
	U2-06	Motor speed at fault (U1-05)	0.01%	○	○
	U2-07	Output voltage reference at fault (U1-06)	0.1V	○	○
	U2-08	DC bus voltage at fault (U1-07)	1V	○	○
	U2-09	Output power at fault (U1-08)	0.1kW	○	○
	U2-10	Torque reference at fault (U1-09)	0.1%	○	○
	U2-11	Input terminal status at fault (U1-10)	—	○	○
	U2-12	Output terminal status at fault (U1-11)	—	○	○
	U2-13	Operation status at fault (U1-12)	[Bit]	○	○
	U2-14	Cumulative operation time at fault (U1-13)	1H	○	○
	U2-15	Motor q-axis current at fault (U1-18)	0.1%	○	○
	U2-16	Motor d-axis current at fault (U1-19)	0.1%	○	○
	U2-17	Operation status at fault 2 (U1-42)	[Bit]	○	○
	U2-18	Command 1 from transmission option at fault (U1-43)	[Bit]	○	○
	U2-19	Command 2 from transmission option at fault (U1-44)	[Bit]	○	○
	U2-20	External torque reference at fault (U1-45)	0.01%	○	○
	U2-21	Torque compensation at fault (U1-46)	0.01%	x	○
	U2-22	ASR output at fault (U1-22)	0.01%	○	○
	U2-23	Output voltage phase at fault (U1-36)	0.1deg	○	○
	U2-24	Magnetic-pole position detection value at fault (U1-37)	0.1deg	x	○
	U2-25	Magnetic-pole position detection estimated value at fault (U1-38)	0.1deg	○	x
Fault Record	U3-01	Most recent fault	[Error display]	○	○
	U3-02	Second most recent fault	[Error display]	○	○
	U3-03	Third most recent fault	[Error display]	○	○
	U3-04	Fourth / Oldest fault	[Error display]	○	○
	U3-05	Cumulative operation time at fault	1H	○	○
	U3-06	Accumulated time of second fault	1H	○	○
	U3-07	Accumulated time of third fault	1H	○	○
	U3-08	Accumulated time of fourth / oldest fault	1H	○	○

*1 Even if ○ is indicated, some constants are not displayed depending on access level.

*2 0.01A for models of 7.5 kW or below.

Table A-5 Constants List

Constant No.	Name	Initial Setting	User Setting	Constant No.	Name	Initial Setting	User Setting
A1-01	Constant access level	2		C1-10	Accel/decel time setting unit	1	
A1-02	Control method selection	5 *1		C1-11	Accel/decel time switching speed	0.00	
A1-03	Initialize	0000		C2-12	Leading phase compensation amount	-5.6	
A1-04	Password 1 (for input)	0		C2-13	PG zero-pulse compensation amount	0.0	
b1-01	Speed reference selection	1		C3-01	Energy-saving control selection	1	
b1-02	Run command selection	1		C3-05	Voltage limit control selection	1	
b1-03	Stopping method selection	0		C5-01	ASR proportional (P) gain 1	*2	
b1-04	Prohibition of reverse operation	0		C5-02	ASR integral (I) time 1	*2	
b1-05	Operation selection for setting of E1-08 or less	*2		C5-03	ASR proportional (P) gain 2	*2	
b1-06	Operation selection after switching to remote mode	0		C5-04	ASR integral (I) time 2	*2	
b2-01	Zero-speed level	*2		C5-05	ASR primary delay time	*2	
b3-02	Magnetic-pole lead-in current	80		C5-06	ASR switching speed	*2	
b3-04	Current positive start time	0.2		C5-07	ASR proportional (P) gain at start	20.00	
b3-05	Magnetic-pole lead-in time	0.0		C6-02	Carrier frequency selection	*3	
b4-01	Timer function ON-delay time	0.0		C6-07	γ -axis voltage offset	-1.0	
b4-02	Timer function OFF-delay time	0.0		C6-11	Adaptive control selection	0	
b5-01	PID control mode selection	0		C6-12	Adaptive control compensation gain	0.95	
b5-02	Proportional gain (P)	1.00		d1-01	Speed reference 1	0.00	
b5-03	Integral (I) time	1.0		d1-02	Speed reference 2	0.00	
b5-04	Integral (I) limit	100.0		d1-03	Speed reference 3	0.00	
b5-05	Differential (D) time	0.00		d1-04	Speed reference 4	0.00	
b5-06	PID limit	100.0		d1-05	Speed reference 5	0.00	
b5-07	PID offset adjustment	0.0		d1-06	Speed reference 6	0.00	
b5-08	PID primary delay time	0.00		d1-07	Speed reference 7	0.00	
b6-01	Dwell speed at start	0.00		d1-08	Speed reference 8	0.00	
b6-02	Dwell time at start	0.0		d1-09	Jog speed reference	10.00	
b6-03	Dwell speed at stop	0.00		d2-01	Speed reference upper limit	100.0	
b6-04	Dwell time at stop	0.0		d2-02	Speed reference lower limit	0.0	
b7-01	Droop control amount	0.0		d3-01	Jump frequency 1	0.0	
b7-02	Droop control time	0.10		d3-02	Jump frequency 2	0.0	
C1-01	Acceleration time 1	10.0		d3-03	Jump frequency 3	0.0	
C1-02	Deceleration time 1	10.0		d3-04	Jump frequency width	1.0	
C1-03	Acceleration time 2	10.0		d4-01	Speed reference hold function selection	0	
C1-04	Deceleration time 2	10.0		d5-01	Torque control selection	0	
C1-05	Acceleration time 3	10.0		d5-02	Torque reference delay time	0	
C1-06	Deceleration time 3	10.0		d5-03	Speed limit selection	1	
C1-07	Acceleration time 4	10.0		d5-04	Speed limit	0	
C1-08	Deceleration time 4	10.0		d5-05	Speed limit bias	5	
C1-09	Emergency stop time	10.0		d5-06	Speed/torque control switching timer	50	

*1 Not initialized.

*2 Differs depending on the control method selection (A1-02).

*3 Setting range and initial setting differ depending on inverter capacity.

Table A-5 Constants List (Cont'd)

Constant No.	Name	Initial Setting	User Setting	Constant No.	Name	Initial Setting	User Setting
E1-01	Input voltage setting	200 *1 *2		F6-01	DO-08 output mode selection	0	
E1-02	Motor capacity selection	*2 *3		F9-01	Input level of external fault from transmission option	0	
E1-03	Motor rated voltage	*2 *3		F9-02	External fault from transmission option	0	
E1-04	Motor rated current	*2 *3 *4		F9-03	Operation at external fault input from transmission option	1	
E1-05	Number of motor poles	*2 *3		F9-04	Trace sampling cycle of transmission option	0	
E1-06	Motor max. speed	*2 *3		F9-05	Selection of torque reference from transmission option	1	
E1-07	Motor base speed	*2 *3		F9-06	Operation selection at BUS error detection	1	
E1-08	Motor min. speed	*2 *3		H1-01	Multi-function input (terminal 3-11)	24	
E1-09	Motor armature resistance	*2 *3		H1-02	Multi-function input (terminal 4-11)	14	
E1-10	Motor d-axis inductance	*2 *3		H1-03	Multi-function input (terminal 5-11)	3 (0) *5	
E1-11	Motor q-axis inductance	*2 *3		H1-04	Multi-function input (terminal 6-11)	4 (3) *5	
E1-13	Induced voltage	*2 *3		H1-05	Multi-function input (terminal 7-11)	6 (4) *5	
E1-14	Variable torque/constant torque selection	0 *2		H1-06	Multi-function input (terminal 8-11)	8 (6) *5	
E1-15	Motor mechanical loss	0.0 *2		H2-01	Multi-function input (terminal 9-10)	0	
E1-16	Motor wiring resistance	1.0 *2		H2-02	Multi-function input (terminal 25-27)	1	
F1-01	PG constants	1024		H2-03	Multi-function input (terminal 26-27)	2	
F1-02	Operation selection at PG open-circuit (PGO) detection	1		H3-01	Signal level selection (terminal 13)	0	
F1-03	Operation selection at overspeed (OS) detection	1		H3-02	Gain (terminal 13)	100.0	
F1-04	Operation selection at speed deviation (DEV) detection	3		H3-03	Bias (terminal 13)	0.0	
F1-05	PG rotation direction	1		H3-04	Signal level selection (terminal 16)	0	
F1-08	Overspeed (OS) detection level	115		H3-05	Multi-function analog input (terminal 16)	00	
F1-09	Overspeed (OS) detection delay time	0.0		H3-06	Gain (terminal 16)	100.0	
F1-10	Speed deviation (DEV) detection level	10		H3-07	Bias (terminal 16)	0.0	
F1-11	Speed deviation (DEV) detection delay time	0.5		H3-08	Signal level selection (terminal 14)	2	
F1-13	PG open-circuit (PGO) detection delay time	3.0		H3-09	Multi-function analog input (terminal 14)	1F	
F2-01	AI-14B input function selection	0		H3-10	Gain (terminal 14)	100.0	
F3-01	DI-08, DI-16H2 speed reference setting selection	0		H3-11	Bias (terminal 14)	0.0	
F4-01	AO-08, 12CH1 output item selection	5		H3-12	Analog input filter time	0.00	
F4-02	AO-08, 12CH1 output gain	1.0		H4-01	Monitor selection (terminal 21-22)	5	
F4-03	AO-08, 12CH1 output bias	0.0		H4-02	Gain (terminal 21-22)	1.0	
F4-04	AO-08, 12CH2 output item selection	3		H4-03	Bias (terminal 21-22)	0.0	
F4-05	AO-08, 12CH2 output gain	1.0		H4-04	Monitor selection (terminal 23-22)	3	
F4-06	AO-08, 12CH2 output bias	0.0		H4-05	Gain (terminal 23-22)	1.0	
F5-01	DO-02 CH1 output selection	0		H4-06	Bias (terminal 23-22)	0.0	
F5-02	DO-02 CH2 output selection	1		H4-07	Analog output signal level selection	1	

*1 Set value for 200V class. For 400V class, the value is twice as that of 200V class.

*2 Not initialized.

*3 Initial setting differs depending on motor capacity.

*4 0.01A for models of 7.5 kW or below.

*5 Initial settings in the parentheses are values obtained at 3-wire initialization.

Table A-5 Constants List (Cont'd)

Constant No.	Name	Initial Setting	User Setting	Constant No.	Name	Initial Setting	User Setting
L1-01	Motor protection selection	1		o1-01	Monitor selection	6	
L1-02	Motor protection time	60.0		o1-02	Monitor selection after power up	1	
L2-01	Momentary power loss detection	0		o1-03	Units of speed reference setting and monitor	1	
L2-02	Momentary power loss ridethru time	*1		o2-01	LOCAL/REMOTEkey enable/disable	1	
L2-03	Deceleration time at momentary power loss	30.0		o2-02	STOP key during control circuit terminal operation	0	
L2-05	Undervoltage detection level	190 *2		o2-04	kVA selection	*1 *5	
L3-01	Overvoltage prevention function selection *3	1		o2-05	Speed reference setting method selection	0	
L4-01	Speed detection level	0.0		o2-06	Operation selection when digital operator is disconnected	0	
L4-02	Speed detection width	2.0		o2-07	Cumulative operation time setting	—	
L4-03	Speed detection level (+/-)	0.0		o2-08	Cumulative operation time selection	0	
L4-04	Speed detection width (+/-)	2.0		T1-02	Tuning mode	0	
L4-05	Operation when speed reference is missing	0		T1-03	Tuning item selection	1	
L5-01	Number of auto restart attempts	0					
L5-02	Auto restart operation selection	0					
L6-01	Torque detection selection 1	0					
L6-02	Torque detection level 1	150					
L6-03	Torque detection time 1	0.1					
L6-04	Torque detection selection 2	0					
L6-05	Torque detection level 2	150					
L6-06	Torque detection time 2	0.1					
L7-01	Forward torque limit	160					
L7-02	Reverse torque limit	160					
L7-03	Forward regenerative torque limit	160					
L7-04	Reverse regenerative torque limit	160					
L8-01	Protect selection for internal DB resistor *4	0					
L8-02	Inverter overheat pre-alarm level	95					
L8-03	Operation selection after inverter overheat pre-alarm	3					
L8-05	Input open-phase protection selection	0					
L8-07	Output open-phase protection selection	0					
L8-10	Ground fault protection selection	1					
L9-01	Step-out protection selection	1					
L9-02	Output current unbalance protection selection *6	1					

*1 Setting range and initial setting differ depending on inverter capacity.

*2 Set value for 200V class. For 400V class, the value is twice as that of 200V class.

*3 When using a braking resistor unit, set L3-01 to "0."

*4 When using a mounting-type braking resistor unit (model ERF), set L8-01 to "1."

*5 Not initialized.

*6 The display is applicable for software No. 1033 or later (FLASH side). To check which version is being used, refer to U1-14.

Table A-6 Motor Capacity Selection List

200V Class

Motor Output (kW)	1750 min ⁻¹	1450 min ⁻¹	1150 min ⁻¹
0.4	000	100	200
0.75	001	101	201
1.5	002	102	202
2.2	003	103	203
3.7	004	104	204
5.5	005	105	205
7.5	006	106	206
11	007	107	207
15	008	108	208
18.5	009	109	209
22	00A	10A	20A
30	00B	10B	20B
37	00C	10C	20C
45	00D	10D	20D
55	00E	10E	20E
75	00F	10F	20F

400V Class

Motor Output (kW)	1750 min ⁻¹	1450 min ⁻¹	1150 min ⁻¹
0.4	020	120	220
0.75	021	121	221
1.5	022	122	222
2.2	023	123	223
3.7	024	124	224
4.0	025	125	225
5.5	026	126	226
7.5	027	127	227
11	028	128	228
15	029	129	229
18.5	02A	12A	22A
22	02B	12B	22B
30	02C	12C	22C
37	02D	12D	22D
45	02E	12E	22E
55	02F	12F	22F
75	030	130	230
90	031	131	231
110	032	132	232
132	033	133	233
160	034	134	234
200	035	135	235
250	036	136	—
300	037	—	—

APPENDIX 5 ERROR PROCESSING IN PG ZERO-PULSE ADJUSTMENT

Fault (major, minor) which could occur during normal operation is also detected during PG zero-pulse adjustment. If a fault occurs including minor fault, the motor stops after coasting (baseblock) and PG zero-pulse adjustment is interrupted regardless of the fault stop mode.

During PG zero-pulse adjustment, errors indicated in the table below are also detected in addition to the faults which could occur in normal operation. The motor stops after coasting (baseblock) and PG zero-pulse adjustment is interrupted if any of these errors is detected. The error messages are not recorded in the fault history.

When the PG zero-pulse adjustment is interrupted, the value set for T1-02 is automatically returned to “0.” The setting for all constants (including T1-0□) is automatically returned to the setting made before the start of PG zero-pulse adjustment and the setting of these constants cannot be changed.

Table A-7 PG Zero-pulse Adjustment Error Messages

Error Message	Contents	Description
<i>Er-02</i>	Motor speed error	Motor speed is not reached the commanded speed even after waiting regular interval.
<i>Er-10</i>	Stop command input	The stop command is input by depressing STOP key, etc.
<i>Er-18</i>	PG zero-pulse adjustment error	<ul style="list-style-type: none"> • Tuning not completed within 40 seconds. • Faulty value for zero-pulse compensation amount.

Follow the corrective actions shown in Fig. A-1.

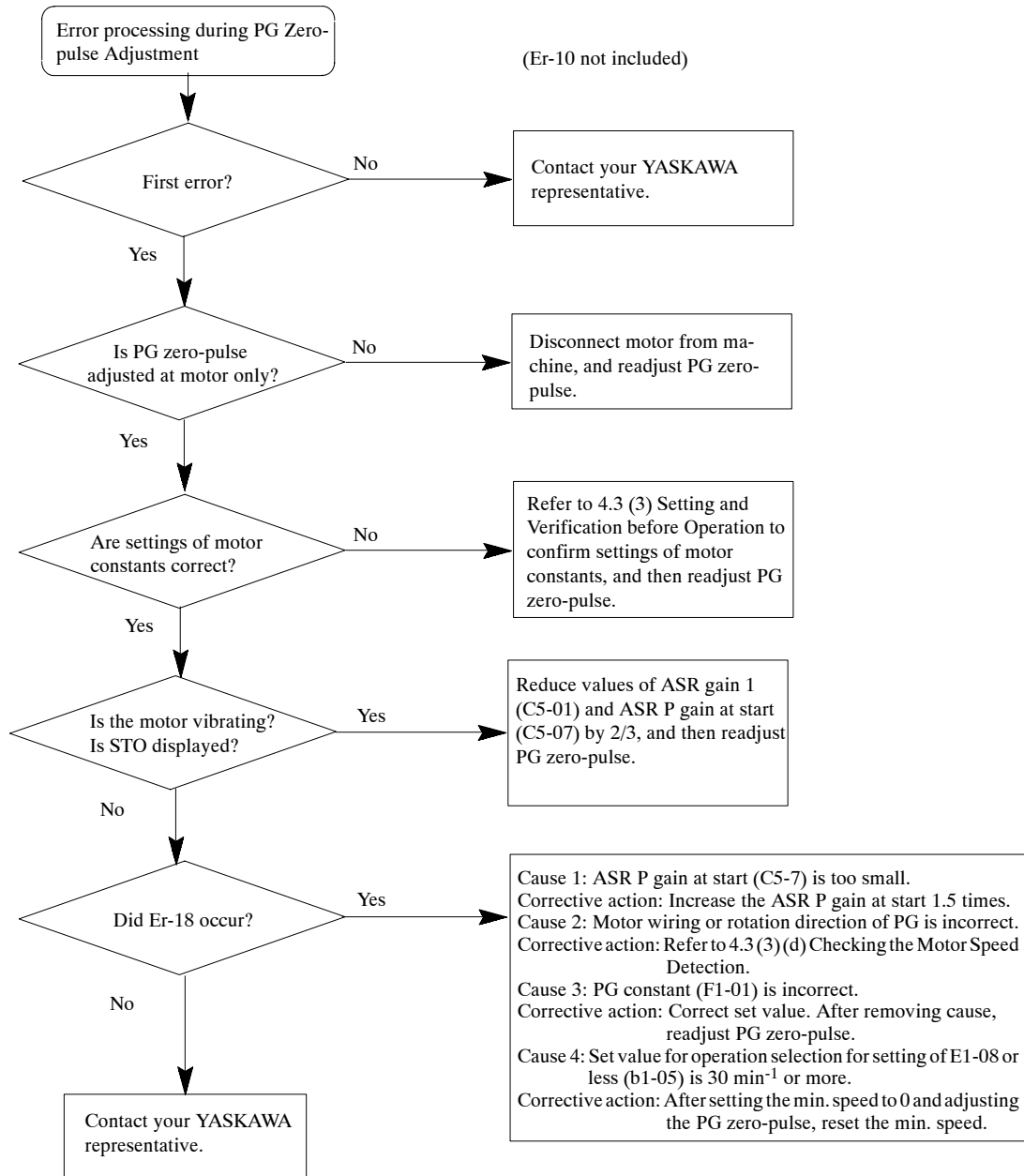

Note: If the acceleration/deceleration times (C1-01 and C1-02) are set to values other than their initial settings, change them back to their initial values and then adjust the PG zero-pulse.

Fig. A-1 Error Processing in PG Zero-pulse Adjustment

APPENDIX 6 ROTATION DIRECTION OF MOTOR

If the standard connection is used for the output terminals of the main circuit, the motor rotates counterclockwise as viewed from the load side of the motor in a forward operation.

To rotate the motor clockwise in a forward operation, use the following procedures to change the connection of the terminals and the setting of the constants, check the motor speed detection, and adjust the PG zero-pulse.

- (1) Reconnect the output terminals of the main circuit:

Connect motor lead V to output terminal W.

Connect motor lead W to output terminal V.

Do not change the connection between lead U and output terminal U.

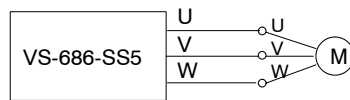

Standard Connection

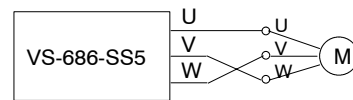

Modified Connection

- (2) Modify the setting of constant F1-05 (For flux vector control with PG)

Set F1-05 (PG rotation direction) to 0.

- (3) Check the motor speed detection (For flux vector control with PG)

Refer to page 48.

- (4) Adjust the PG zero-pulse (For flux vector control with PG)

Refer to page 49.

NOTE

- Do not change the connection of the PG cable.
- If the rotation direction of the motor is set to clockwise for a forward operation (Refer to Fig.A-2), change the connection of the output terminal of the main circuit to the standard connection and then proceed to steps (2) through (4).

Example) SSR1 – 20P4AEN – SAD1BES
 Basic Model Optional Model

The wavy lined code A: Counterclockwise rotation for forward operation (standard)
 The wavy lined code B: Clockwise rotation for forward operation

Note: This example applies to optional model.

Fig. A-2 Rotation Direction for Motor Model

APPENDIX 7 ZDEV CAUSES AND CORRECTIVE ACTIONS LIST

ZDEV Error	Detection	Causes	Corrective Actions
Phase-Z pulse not counted detection Error display: ZDEV	Although the pulses of phase-A or -B were counted while the motor rotated 3 times, the pulses of phase-Z were never counted. Detected while the power supply is ON.	<ul style="list-style-type: none"> • Incorrect wiring of PG cable • Damaged PG card • Damaged PG (motor side) 	<ol style="list-style-type: none"> 1. Check the PG cable connection. 2. Check the A, B, and Z pulses using the check pins on the PG card. If an erroneous pulse is detected, investigate the noise source. If leakage from the power supply is the cause, modify the grounding line. If an usual waveform is detected, replace the PG card or PG.
Phase-Z noise error detection Error display: ZDEV	The phase-Z pulse has been detected to have unusual timing 10 consecutive times (The difference between the previously detected phase-Z and the currently detected phase-Z is outside of the allowable range of ± 5 degrees for the electrical angle during one motor rotation.) Detected while the power supply is ON.	<ul style="list-style-type: none"> • Noise interference on PG cable • Incorrect wiring of PG cable • Damaged PG card • Damaged PG (motor side) 	<ol style="list-style-type: none"> 1. Check the PG cable connection. 2. Check the A, B, and Z pulses using the check pins on the PG card. If an erroneous pulse is detected, investigate the noise source. If leakage from the power supply is the cause, change the grounding line. If an usual waveform is detected, replace the PG card or PG.
Reverse detection detected Error display: ZDEV	If the torque reference is positive (negative). 1. In the state where the acceleration speed is negative (positive), the difference between the speed reference and the motor speed is continuously 10% or more for the detection time (constant F1-11) or longer. 2. In the state where the acceleration speed is negative (positive), the difference between the speed reference and the motor speed is 30% or more. Detected only while the motor is running.	<ul style="list-style-type: none"> • Incorrect setting of PG zero-pulse compensation amount (C2-13) • Noise interference on PG cable (phase A or -B) • Incorrect wiring of PG cable • Damaged PG card • Damaged PG (motor side) • One of the operation conditions described in the left column was valid. • The main leads of the motor are not correctly connected to the U, V, and W terminals. • The setting of the rotation direction of the PG (F1-05) does not agree with the main leads of the motor. • Disconnection of the PG cable for phase-Z. 	<p>Note: If using standard software, turn OFF the power supply to reset ZDEV.</p> <ol style="list-style-type: none"> 1. Confirm that the main leads of the motor are correctly connected to the U, V, and W terminals. 2. Confirm that the value of $\Delta\theta$ on the motor nameplate is the same as the set value of the PG zero-pulse compensation amount (C2-13). After replacing the PG or changing the direction in which the motor runs forward, adjust the PG zero-pulse. (Refer to page 49 through 51.) 3. Confirm that the motor rotation direction is correct. (Refer to page 48 and 49.) 4. Check if the motor is not rotated from load side under the conditions 1 or 2 described in the left column. 5. Check the A, B, and Z pulses using the check pins on the PG card. If an erroneous pulse is detected, investigate the noise source. If leakage from the power supply is the cause, change the grounding line. If an unusual waveform is detected, replace the PG card or PG. 6. Check the PC card wiring. If any wires are disconnected, reconnect the wires correctly. (Refer to page 22.)

Revision History

The revision dates and numbers of the revised manuals are given on the bottom of the back cover.

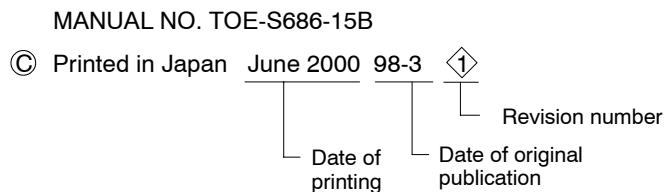

Date of Printing	Rev. No.	Section	Revised Content
March 1998	—	—	First edition
June 2000	①		Partly revised
May 2004	②	All chapters	Revision: Units (r/min to min ⁻¹)
		Preface	Addition: Precautions on constant setting in operation
		4.3 (3) (b)	Addition: Motor model Revision: Setting procedure of motor related constants
		4.3 (4)	Addition: Notes of jog operation procedure
		7.1	Addition: Corrective action of fault display OL1, fault display LF2, and note Revision: Details and corrective action of the fault display EF8
		7.2	Addition: Motor faults and corrective actions
		Appendix 4	Addition: L9-02 of constants list and note
		Appendix 5	Deletion: Auto-tuning method Revision: Fig.A-1
		Appendix 6	Partly revised
		Appendix 7	Addition: Note Revision and Addition: Motor rotation direction
		Appendix 8	Addition: ZDEV causes and corrective actions list
		Revision history	Addition
Back cover	Revision: Address		
February 2006	③	Back cover	Revision: Address

VARISPEED-686SS5 INSTRUCTION MANUAL

IRUMA BUSINESS CENTER (SOLUTION CENTER)

480, Kamifujisawa, Iruma, Saitama 358-8555, Japan
Phone 81-4-2962-5696 Fax 81-4-2962-6138

YASKAWA ELECTRIC AMERICA, INC.

2121 Norman Drive South, Waukegan, IL 60085, U.S.A.
Phone 1-847-887-7000 Fax 1-847-887-7370

YASKAWA ELÉTRICO DO BRASIL COMÉRCIO LTD.A.

Avenida Fagundes Filho, 620 Bairro Saude-Sao Paulo-SP, Brazil CEP: 04304-000
Phone 55-11-5071-2552 Fax 55-11-5581-8795

YASKAWA ELECTRIC EUROPE GmbH

Am Kronberger Hang 2, 65824 Schwalbach, Germany
Phone 49-6196-569-300 Fax 49-6196-569-312

YASKAWA ELECTRIC UK LTD.

1 Hunt Hill Orchardton Woods Cumbernauld, G68 9LF, United Kingdom
Phone 44-1236-735000 Fax 44-1236-458182

YASKAWA ELECTRIC KOREA CORPORATION

7F, Doore Bldg. 24, Yeoido-dong, Youngdungpo-Ku, Seoul 150-877, Korea
Phone 82-2-784-7844 Fax 82-2-784-8495

YASKAWA ELECTRIC (SINGAPORE) PTE. LTD.

151 Lorong Chuan, #04-01, New Tech Park 556741, Singapore
Phone 65-6282-3003 Fax 65-6289-3003

YASKAWA ELECTRIC (SHANGHAI) CO., LTD.

No.18 Xizang Zhong Road. Room 1702-1707, Harbour Ring Plaza Shanghai 200001, China
Phone 86-21-5385-2200 Fax 86-21-5385-3299

YASKAWA ELECTRIC (SHANGHAI) CO., LTD. BEIJING OFFICE

Room 1011A, Tower W3 Oriental Plaza, No.1 East Chang An Ave.,
Dong Cheng District, Beijing 100738, China
Phone 86-10-8518-4086 Fax 86-10-8518-4082

YASKAWA ELECTRIC TAIWAN CORPORATION

9F, 16, Nanking E. Rd., Sec. 3, Taipei, Taiwan
Phone 886-2-2502-5003 Fax 886-2-2505-1280



YASKAWA ELECTRIC CORPORATION

YASKAWA

In the event that the end user of this product is to be the military and said product is to be employed in any weapons systems or the manufacture thereof, the export will fall under the relevant regulations as stipulated in the Foreign Exchange and Foreign Trade Regulations. Therefore, be sure to follow all procedures and submit all relevant documentation according to any and all rules, regulations and laws that may apply.

Specifications are subject to change without notice for ongoing product modifications and improvements.

© 1998-2006 YASKAWA ELECTRIC CORPORATION. All rights reserved.

MANUAL NO. TOE-S686-15B

Printed in Japan February 2006 98-3

05-7⑦