

# AC SERVO DRIVES BULLETIN

ALL DIGITAL, FOR SPEED CONTROL

SERVOMOTOR: TYPES USAMED, USAFED, USAGED,  
USADED, USASEM (With Optical Encoder)

SERVOPACK : TYPE CACR-SR  BE1

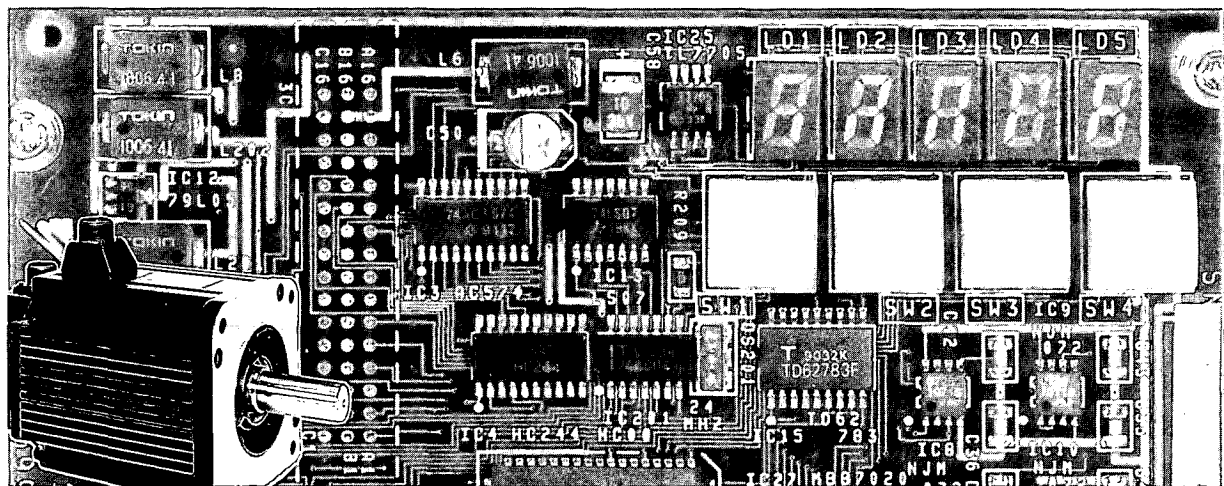

YASKAWA all-digital AC Servo Drives provide mechatronics drives for the most advanced FA and FMS including robots and machine tools. These drives are the result of the most advanced servo drive manufacturing technology available anywhere in the world.

For your mechatronics systems, take advantage of the flexible combination of our AC SERVOMOTOR and SERVOPACK to achieve quick response and smooth, powerful operation even at low-speed range.

## FEATURES

- Compact design and simple wiring
- Stable operation with all digital control  
(Stable adjustment with parameter)
- Versatile Functions (torque control, soft start, etc)
- High reliability

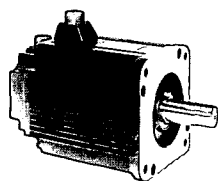

M Series

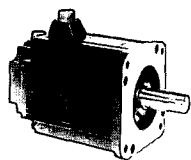

F Series

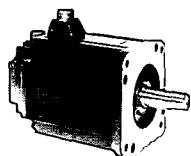

G Series

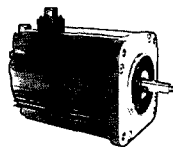

S Series

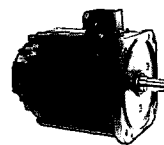

D Series

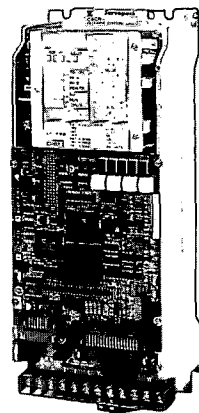

SERVOPACK

# CONTENTS

- 1. RATINGS AND SPECIFICATIONS / 1**
  - 1.1 RATINGS AND SPECIFICATIONS OF M SERIES AC SERVOMOTORS / 1
  - 1.2 RATINGS AND SPECIFICATIONS OF F SERIES AC SERVOMOTORS / 3
  - 1.3 RATINGS AND SPECIFICATIONS OF G SERIES AC SERVOMOTORS / 5
  - 1.4 RATINGS AND SPECIFICATIONS OF S SERIES AC SERVOMOTORS / 7
  - 1.5 RATINGS AND SPECIFICATIONS OF D SERIES AC SERVOMOTORS / 9
  - 1.6 RATINGS AND SPECIFICATIONS OF SERVOPACK / 11
- 2. TYPE DESIGNATION / 13**
- 3. LIST OF STANDARD COMBINATION / 15**
- 4. CHARACTERISTICS / 19**
  - 4.1 OVERLOAD CHARACTERISTICS / 19
  - 4.2 STARTING AND STOPPING TIME / 20
  - 4.3 ALLOWABLE FREQUENCY OPERATION / 21
  - 4.4 SERVOMOTOR FREQUENCY / 23
  - 4.5 MOTOR SPEED-REFERENCE INPUT CHARACTERISTICS / 23
  - 4.6 MOTOR MECHANICAL CHARACTERISTICS / 24
- 5. CONFIGURATION / 28**
  - 5.1 CONNECTION DIAGRAM / 28
  - 5.2 MAIN CIRCUIT TERMINALS / 29
  - 5.3 APPLICABLE RECEPTACLES / 29
  - 5.4 CONNECTOR TERMINAL (1CN) FOR I/O SIGNAL / 30
  - 5.5 CONNECTOR TERMINAL (2CN) FOR OPTICAL ENCODER CONNECTION / 38
  - 5.6 INTERNAL BLOCK DIAGRAM / 40
- 6. OPERATION / 42**
  - 6.1 POWER ON AND OFF / 42
  - 6.2 SPEED REFERENCE / 43
  - 6.3 TORQUE CONTROL / 45
  - 6.4 EXTERNAL CURRENT LIMIT REFERENCE CIRCUIT [P-CL, N-CL] / 48
  - 6.5 PROTECTIVE FUNCTIONS / 50
  - 6.6 PRECAUTIONS FOR APPLICATION / 53
  - 6.7 PRECAUTIONS FOR OPERATION / 54
  - 6.8 APPLICATION / 57
  - 6.9 MOTOR SPEED AND TORQUE MEASUREMENT / 59
- 7. USER CONSTANTS / 62**
- 8. MONITOR PANEL OPERATION / 66**
  - 8.1 SWITCH OPERATION / 66
  - 8.2 FUNCTIONS OF MONITOR PANEL / 67
  - 8.3 STATUS INDICATION MODE / 68
  - 8.4 SETTING MODE / 69
  - 8.5 MONITOR MODE / 85
  - 8.6 FAULT TRACEBACK MODE / 87
- 9. INSTALLATION AND WIRING / 89**
  - 9.1 RECEIVING / 89
  - 9.2 INSTALLATION / 89
  - 9.3 WIRING / 94
- 10. DIMENSIONS / 97**
  - 10.1 SERVOMOTOR / 97
  - 10.2 SERVOPACK / 110
  - 10.3 PERIPHERAL DEVICES / 113
- 11. TEST RUN / 116**
  - 11.1 CHECK ITEMS BEFORE TEST RUN / 116
  - 11.2 TEST RUN PROCEDURES / 116
- 12. ADJUSTMENT / 118**
  - 12.1 CHARACTERISTICS PRESET AT THE FACTORY PRIOR TO SHIPMENT / 118
  - 12.2 READJUSTMENT / 119
- 13. INSPECTION AND MAINTENANCE / 120**
  - 13.1 AC SERVOMOTOR / 120
  - 13.2 SERVOPACK / 121
- 14. TROUBLESHOOTING / 122**
  - 14.1 SERVOMOTOR / 122
  - 14.2 SERVOPACK / 123

# INDEX

Subject	Chapter	Section	Page
<b>A</b> AC SERVOMOTOR .....	13	13.1	120
AC SERVOMOTOR .....	9	9.2.1	89
ADJUSTMENT .....	12		118
ALLOWABLE FREQUENCY OF OPERATION .....	4	4.3	21
Allowable Radial Load and Thrust Load .....	4	4.6.2	24
APPLICABLE RECEPTACLES .....	5	5.3	29
APPLICATION .....	6	6.8	59
Application of SERVOMOTORS with Holding Magnetic Brake .....	6	6.9.2	61
Auxiliary Input Circuit ( $\pm 2$ to $\pm 10V$ ) .....	6	6.2.4	44
<b>C</b> Cable Specifications .....	5	5.5.2	38
CHARACTERISTICS PRESET AT THE FACTORY PRIOR TO SHIPMENT .....	12	12.1	118
CHARACTERISTICS .....	4		19
CHECK ITEMS BEFORE TEST RUN .....	11	11.1	116
Clearing Fault Traceback Data .....	8	8.4.5	78
CONFIGURATION .....	5		28
CONNECTION DIAGRAM .....	5	5.1	28
Connection for Reverse Motor Running .....	6	6.8.1	59
Connector 1CN Layout and Connection of SERVOPACK .....	5	5.4.1	30
Connector Layout .....	5	5.5.1	38
CONNECTOR TERMINAL (2CN) FOR OPTICAL ENCODER CONNECTION .....	5	5.5	38
CONNECTOR TERMINAL (1CN) FOR I/O SIGNAL .....	5	5.4	30
Current Limit when Motor is Locked .....	6	6.4.3	49
<b>D</b> D Series .....	10	10.1.4	105
DIMENSIONS in mm (inches) .....	10		97
Direction of Rotation .....	4	4.6.4	25
Examples of Troubleshooting for Defective Wiring or Parts .....	14	14.2.2	125
Examples of Troubleshooting for Incomplete Adjustment .....	14	14.2.3	125
EXTERNAL CURRENT LIMIT REFERENCE CIRCUIT [P-CL, N-CL] .....	6	6.4	48
<b>F</b> F Series .....	10	10.1.2	99
FAULT TRACEBACK MODE .....	8	8.6	87
<b>G</b> G Series .....	10	10.1.3	102
<b>H</b> Handling of Speed Reference Input Terminal .....	6	6.2.3	44
High Voltage Line .....	6	6.6.3	53
<b>I</b> Impact Resistance .....	4	4.6.5	26
Input Circuit .....	5	5.4.3	33
Input Signals of Connector 1CN .....	5	5.4.2	32
INSPECTION AND MAINTENANCE .....	13		120
Inspection during Test Run .....	11	11.2.3	117
INSTALLATION AND WIRING .....	9		89
INSTALLATION .....	9	9.2	89
INTERNAL CONNECTION DIAGRAM .....	5	5.6	40
<b>J</b> Jog Function .....	6	6.2.7	45
<b>L</b> LED Indication (7-segment) for Troubleshooting .....	14	14.2.1	123
LIST OF STANDARD COMBINATION .....	3		15
Load Inertia ( $J_L$ ) .....	6	6.6.2	53
<b>M</b> M Series .....	10	10.1.1	97
MAIN CIRCUIT TERMINALS .....	5	5.2	29
Mechanical Specifications .....	4	4.6.3	25
Mechanical Strength .....	4	4.6.1	24
Method of Connection .....	5	5.5.3	39
Method of Giving External Current Limit Reference .....	6	6.4.1	48
MONITOR MODE .....	8	8.5	85
Monitor Panel Controlled Operation Mode Selection and Operating Procedure .....	8	8.4.3	75
MONITOR PANEL FUNCTIONS .....	8	8.2	67
MONITOR PANEL OPERATION .....	8		66

# INDEX (Cont'd)

Subject	Chapter	Section	Page
<b>M</b> Monitor Terminals .....	6	6.9.1	59
MOTOR MECHANICAL CHARACTERISTICS .....	4	4.6	24
MOTOR SPEED AND TORQUE MEASUREMENT .....	6	6.9	59
MOTOR SPEED-REFERENCE INPUT CHARACTERISTICS .....	4	4.5	23
<b>N</b> Noise Control .....	6	6.7.1	54
<b>O</b> Operation .....	11	11.2.2	117
OPERATION .....	6		42
Output Circuit .....	5	5.4.5	36
Overhanging Loads .....	6	6.6.1	53
OVERLOAD CHARACTERISTICS .....	4	4.1	19
<b>P</b> PERIPHERAL DEVICES in mm (inches) .....	10	10.3	113
Power Line Protection .....	6	6.8.2	57
Power Loss .....	9	9.3.3	84
POWER ON AND OFF .....	6	6.1	41
PRECAUTIONS FOR APPLICATION .....	6	6.6	53
PRECAUTIONS FOR OPERATION .....	6	6.8	57
Preparation for Operation .....	11	11.2.1	116
PROTECTIVE FUNCTIONS .....	6	6.5	50
<b>R</b> Rated Current and Cable Size .....	9	9.3.1	94
RATINGS AND SPECIFICATIONS OF SERVOPACK .....	1	1.6	11
RATINGS AND SPECIFICATIONS .....	1		1
READJUSTMENT .....	12	12.2	119
RECEIVING .....	9	9.1	89
<b>S</b> S Series .....	10	10.1.5	106
SERVOMOTOR FREQUENCY .....	4	4.4	23
SERVOMOTOR .....	10	10.1	97
SERVOMOTOR .....	11	11.1.1	116
SERVOMOTOR .....	14	14.1	122
Set Voltage and Current Limit Values .....	6	6.4.2	49
SETTING MODE .....	8	8.4	69
Soft Start Function .....	6	6.2.6	44
Specifications of Connector Terminal (1CN) for Input/Output Signal .....	5	5.3.1	29
Specifications of Connector Terminal (2CN) for Encoder .....	5	5.3.2	29
Speed Control with Zero Clamp .....	6	6.2.5	45
Speed Reference Circuit .....	6	6.2.1	43
Speed Reference Offset Adjustment .....	8	8.4.4	77
SPEED REFERENCE .....	6	6.2	43
STARTING AND STOPPING TIME .....	4	4.2	20
STATUS INDICATION MODE .....	8	8.3	68
SWITCH OPERATION .....	8	8.1	66
<b>T</b> TROUBLESHOOTING .....	14		122
TYPE DESIGNATION .....	2		13
<b>U</b> USER CONSTANTS .....	7		62
<b>V</b> Vibration Class .....	4	4.6.7	26
Vibration Resistance .....	4	4.6.6	26

# 1. RATINGS AND SPECIFICATIONS

## 1.1 RATINGS AND SPECIFICATIONS OF M SERIES AC SERVOMOTORS

### 1.1.1 Ratings

Time Rating: Continuous

Insulation: Class F

Isolation Voltage: 1500 VAC, one minute

Insulation Resistance: 500 VDC, 10MΩ  
or more

Enclosure: Totally-enclosed, self-cooled  
(Equivalent to IP-65 exclusive shaft opening)

Ambient Temperature: 0 to +40°C

Ambient Humidity: 20% to 80%  
(non-condensing)

Vibration: 15μm or below

Finish in Munsell Notation: N1.5

Excitation: Permanent magnet

Mounting: Flange mounted

Drive Method: Direct drive

Table 1.1 Ratings and Specifications of M Series AC SERVOMOTOR

Item	Motor Type USAMED- *2	03□□1	06□□1	09B□2	12B□2	20B□2	30B□2	44B□2	USAMKD -60B□2
		Rated Output* kW (HP)	0.3 (0.4)	0.6 (0.8)	0.9 (1.2)	1.2 (1.6)	2.0 (2.7)	3.0 (4.0)	4.4 (5.9)
Rated Torque* N · m (lb · in)	2.84 (25)	5.68 (50)	8.62 (76)	11.5 (102)	19.1 (169)	28.4 (252)	41.9 (372)	57.2 (507)	
Continuous Max Torque* N · m (lb · in)	2.94 (26)	5.88 (52)	8.82 (78)	11.8 (104)	21.6 (191)	32.3 (286)	46.1 (408)	62.9 (557)	
Instantaneous Peak Torque* N · m (lb · in)	7.17 (63)	14.1 (125)	19.3 (171)	28.0 (248)	44.0 (390)	63.7 (564)	91.1 (807)	105.8 (938)	
Rated Current* A	3.0	5.8	7.6	11.7	18.8	26	33	45	
Rated Speed* r/min	1000								
Instantaneous Max Speed* r/min	2000							1500	
Torque Constant N · m/A (lb · in/A)	1.01 (8.9)	1.04 (9.2)	1.21 (10.7)	1.02 (9.0)	1.07 (9.5)	1.16 (10.2)	1.33 (11.8)		
Moment of Inertia J <sub>M</sub> (= GD <sup>2</sup> /4) kg · m <sup>2</sup> × 10 <sup>-4</sup> (lb · in · s <sup>2</sup> × 10 <sup>-3</sup> )	13.5 (12.0)	24.3 (21.5)	36.7 (32.5)	58.0 (51.2)	110 (97.2)	143 (126.7)	240 (212.6)		
Power Rate* kW/s	6.0	13.3	20.3	22.7	33.2	57.0	74.0	138	
Inertia Time Constant ms	12.8	6.3	4.4	6.0	5.2	3.5	3.6	4.0	
Inductive Time Constant ms	2.7	5.1	6.5	10.4	12.9	15.3	16.2		
Insulation	Class F								

\*1: Values when SERVOMOTOR is combined with SERVOPACK and the armature winding temperature is 20°C.  
Shown are normal (TYP) values above.

\*2: The blank □ of motor type depends on class of detectors.

Standard: 2 (8192 pulses/rev)

Semi-Standard: 3 (2048 pulses/rev)

Optical encoder is used as a detector.

Note: The power supply units for brake:

• Input 100 VAC, Output 90 VDC: Type B9400876-2

• Input 200 VAC, Output 90 VDC: Type B9400876-1

For details, see Par. 10.3 (2).

## 1.1.2 Torque-Speed Characteristics

- TYPE USAMED-03

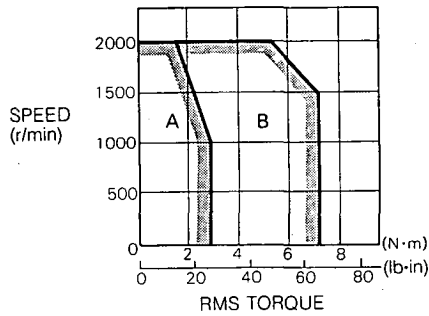

- TYPE USAMED-20B

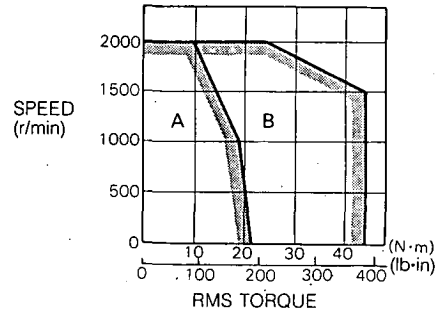

- TYPE USAMED-06

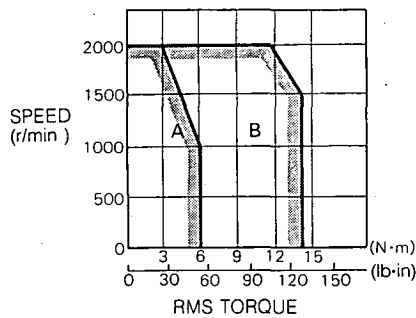

- TYPE USAMED-30B

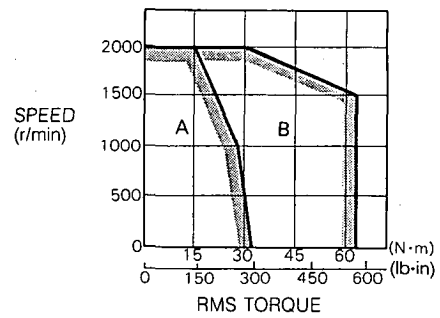

- TYPE USAMED-09B

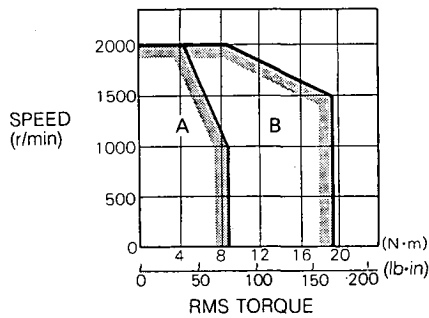

- TYPE USAMED-44B

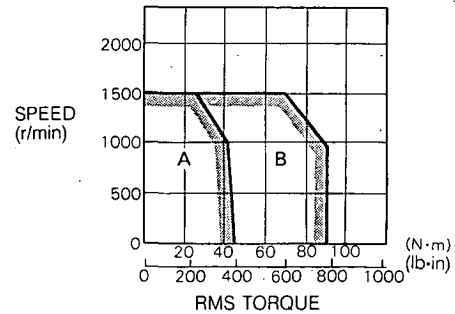

- TYPE USAMED-12B

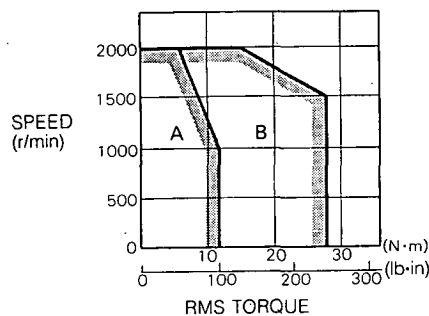

- TYPE USAMKD-60B

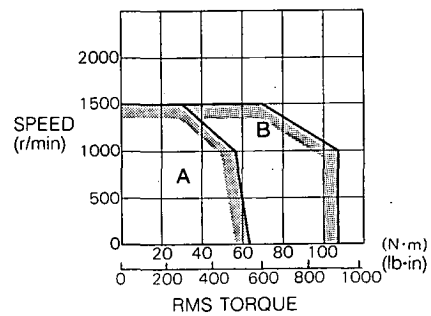

A: CONTINUOUS DUTY ZONE  
 B: INTERMITTENT DUTY ZONE  
 POWER SUPPLY: 200 V

# 1.2 RATINGS AND SPECIFICATIONS OF F SERIES AC SERVOMOTORS

## 1.2.1 Ratings

Time Rating: Continuous

Insulation: Class F

Isolation Voltage: 1500 VAC, one minute

Insulation Resistance: 500 VDC, 10MΩ  
or more

Enclosure: Totally-enclosed, self-cooled  
(Equivalent to IP-65 exclusive shaft opening)

Ambient Temperature: 0 to +40°C

Ambient Humidity: 20% to 80%  
(non-condensing)

Vibration: 15μm or below

Finish in Munsell Notation: N1.5

Excitation: Permanent magnet

Mounting: Flange mounted

Drive Method: Direct drive

Table 1.2 Ratings and Specifications of F Series AC SERVOMOTORS

Motor Type USAFED- *2		02□□1	03□□1	05□□1	09□□1	13C□2	20C□2	30C□2	44C□2
Rated Output*	kW (HP)	0.15 (0.2)	0.3 (0.4)	0.45 (0.6)	0.85 (1.1)	1.3 (1.7)	1.8 (2.4)	2.9 (3.9)	4.4 (5.9)
Rated Torque*	N·m (lb·in)	0.98 (8.7)	1.96 (17)	2.84 (25)	5.39 (48)	8.34 (74)	11.5 (102)	18.6 (165)	28.4 (252)
Continuous Max Torque*	N·m (lb·in)	1.08 (10)	2.16 (19)	2.94 (26)	5.88 (52)	8.83 (78)	11.8 (104)	22.6 (200)	37.3 (330)
Instantaneous Peak Torque*	N·m (lb·in)	2.91 (26)	5.83 (52)	8.92 (79)	15.2 (135)	24.7 (219)	34.0 (301)	54.1 (479)	76.2 (675)
Rated Current*	A	3.0	3.0	3.8	6.2	9.7	15	20	30
Rated Speed*	r/min	1500							
Instantaneous Max Speed*	r/min	2500							
Torque Constant	N·m/A (lb·in/A)	0.36 (3.2)	0.72 (6.3)	0.80 (7.1)	0.92 (8.2)	0.92 (8.2)	0.82 (7.3)	0.98 (8.7)	1.02 (9.0)
Moment of Inertia J <sub>M</sub> (=GD <sup>2</sup> /4)	kg·m <sup>2</sup> ×10 <sup>-4</sup> (lb·in·s <sup>2</sup> ×10 <sup>-3</sup> )	1.3 (1.2)	2.06 (1.8)	13.5 (12.0)	24.3 (21.5)	36.7 (32.5)	58 (51.2)	110 (97.2)	143 (126.7)
Power Rate* <sup>1</sup>	kW/s	7.4	18.3	6.0	12	18.9	22.7	31.5	57.0
Inertia Time Constant	ms	3.9	2.5	10.9	6.0	4.4	5.9	5.2	3.7
Inductive Time Constant	ms	3.4	4.3	3.2	5.2	6.1	10.4	13.0	15.2
Insulation		Class F							

\*1: Values when SERVOMOTOR is combined with SERVOPACK and the armature winding temperature is 20°C. Shown are normal (TYP) values above.

\*2: The blank □ of motor type depends on class of detectors.

Standard: 2 (8192 pulses/rev)

Semi-Standard: 3 (2048 pulses/rev)

Optical encoder is used as a detector.

Note: The power supply units for brake:

• Input 100 VAC, Output 90 VDC: Type B9400876-2

• Input 200 VAC, Output 90 VDC: Type B9400876-1

For details, see Par. 10.3 (2).



## 1.2.2 Torque-Speed Characteristics

- TYPE USAFED-02

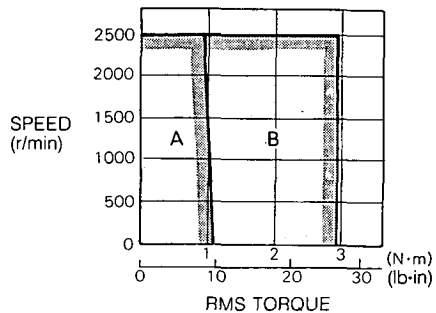

- TYPE USAFED-13C

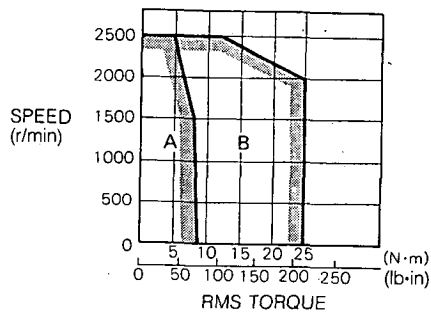

- TYPE USAFED-03

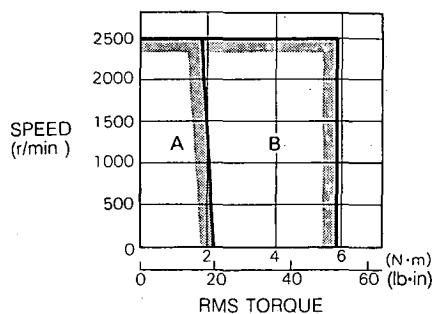

- TYPE USAFED-20C

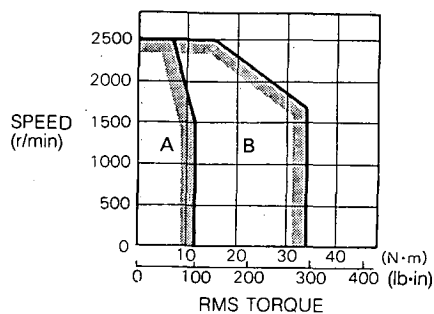

- TYPE USAFED-05

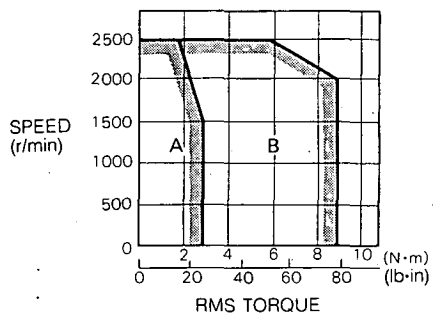

- TYPE USAFED-30C

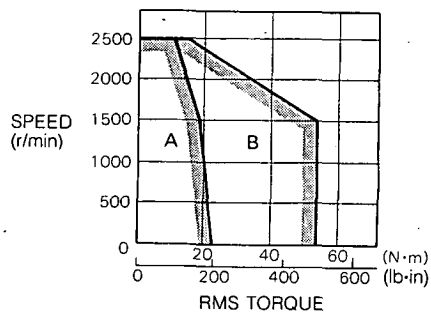

- TYPE USAFED-09

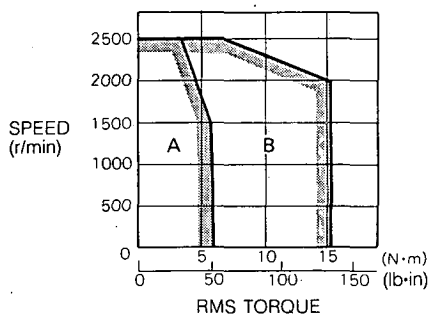

- TYPE USAFED-44C

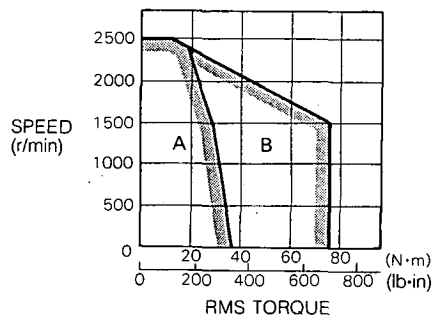

A: CONTINUOUS DUTY ZONE  
 B: INTERMITTENT DUTY ZONE  
 POWER SUPPLY: 200 V

# 1.3 RATINGS AND SPECIFICATIONS OF G SERIES AC SERVOMOTORS

## 1.3.1 Ratings

Time Rating: Continuous

Insulation: Class F

Isolation Voltage: 1500 VAC, one minute

Insulation Resistance: 500 VDC, 10MΩ  
or more

Enclosure: Totally-enclosed, self-cooled  
(Equivalent to IP-65 exclusive shaft opening)

Ambient Temperature: 0 to +40°C

Ambient Humidity: 20% to 80%  
(non-condensing)

Vibration: 15μm or below

Finish in Munsell Notation: N1.5

Excitation: Permanent magnet

Mounting: Flange mounted

Drive Method: Direct drive

Table 1.3 Ratings and Specifications of G Series AC SERVOMOTORS

Item	Motor Type USAGED- *2	Detector Class							
		02□□1	03□□1	05□□1	09□□1	13A□2	20A□2	30A□2	44A□2
Rated Output*	kW (HP)	0.15 (0.2)	0.3 (0.4)	0.45 (0.6)	0.85 (1.1)	1.3 (1.7)	1.8 (2.4)	2.9 (3.9)	4.4 (5.9)
Rated Torque*	N·m (lb·in)	0.98 (8.7)	1.96 (17)	2.84 (25)	5.39 (48)	8.34 (74)	11.5 (102)	18.6 (165)	28.4 (252)
Continuous Max Torque*	N·m (lb·in)	1.08 (10)	2.16 (19)	2.94 (26)	5.88 (52)	8.83 (78)	11.8 (104)	22.6 (200)	37.3 (330)
Instantaneous Peak Torque*	N·m (lb·in)	2.9 (26)	5.83 (52)	8.92 (79)	13.3 (118)	23.3 (207)	28.0 (248)	45.1 (400)	66.2 (587)
Rated Current*	A	3.0	3.0	3.8	7.6	11.7	19	26	33
Rated Speed*	r/min	1500							
Instantaneous Max Speed*	r/min	3000							
Torque Constant	N·m/A (lb·in/A)	0.36 (3.2)	0.72 (6.3)	0.8 (7.1)	0.8 (7.1)	0.83 (7.4)	0.67 (5.9)	0.80 (7.1)	0.95 (8.4)
Moment of Inertia J <sub>M</sub> (=GD <sup>2</sup> /4)	kg·m <sup>2</sup> ×10 <sup>-4</sup> (lb·in·s <sup>2</sup> ×10 <sup>-3</sup> )	1.3 (1.2)	2.06 (1.8)	13.5 (12.0)	24.3 (21.5)	36.7 (32.5)	57.9 (51.2)	110 (97.2)	143 (126.7)
Power Rate* <sup>1</sup>	kW/s	7.4	18.3	6.0	12	18.9	22.7	36.5	57.0
Inertia Time Constant	ms	4.5	2.5	10.9	6.1	4.3	5.8	5.2	3.4
Inductive Time Constant	ms	3.4	4.3	3.2	5.2	6.7	10.6	13.2	15.9
Insulation		Class F							

\*1: Values when SERVOMOTOR is combined with SERVOPACK and the armature winding temperature is 20°C. Shown are normal (TYP) values above.

\*2: The blank □ of motor type depends on class of detectors.

Standard: 2 (8192 pulses/rev)

Semi-Standard: 3 (2048 pulses/rev)

Optical encoder is used as a detector.

Note: The power supply units for brake:

- Input 100 VAC, Output 90 VDC: Type B9400876-2
- Input 200 VAC, Output 90 VDC: Type B9400876-1

For details, see Par. 10.3 (2).

### 1.3.2 Torque-Speed Characteristics

• TYPE USAGED-02

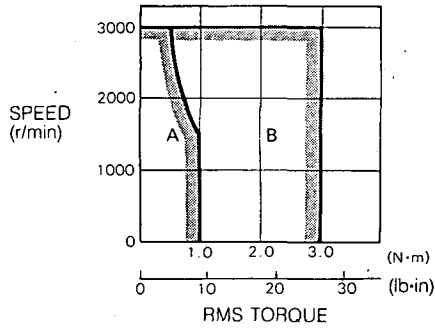

• TYPE USAGED-13A

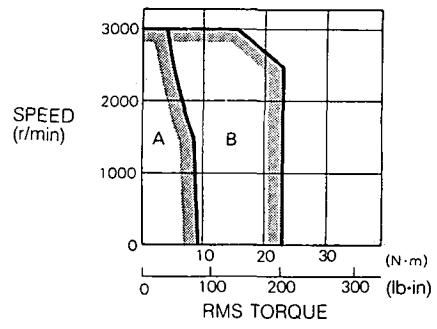

• TYPE USAGED-03

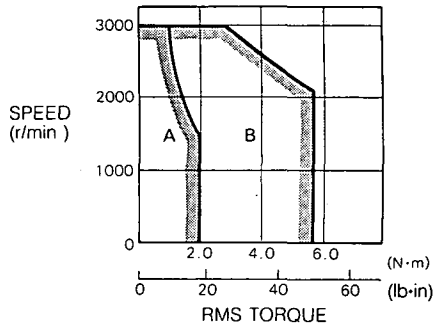

• TYPE USAGED-20A

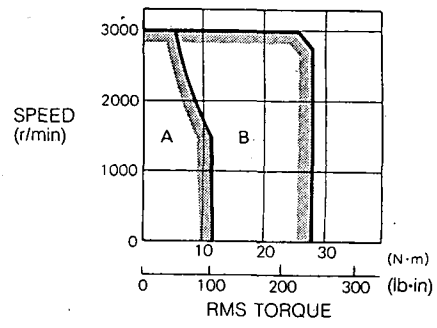

• TYPE USAGED-05

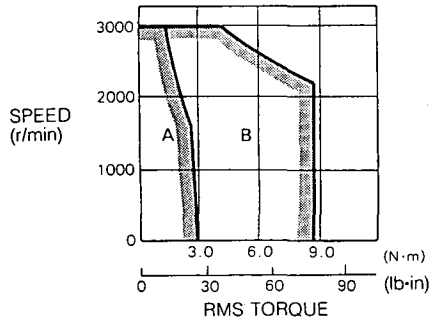

• TYPE USAGED-30A

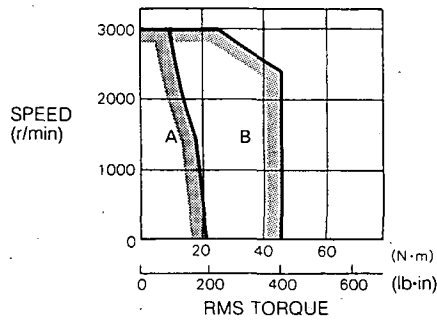

• TYPE USAGED-09

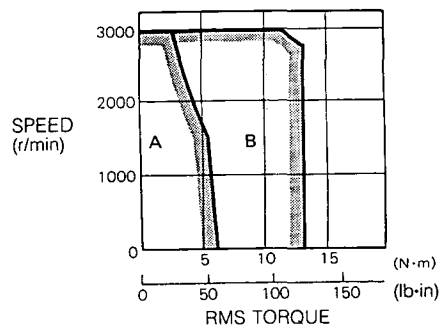

• TYPE USAGED-44A

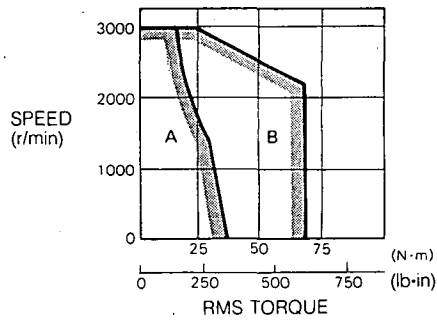

A: CONTINUOUS DUTY ZONE  
 B: INTERMITTENT DUTY ZONE  
 POWER SUPPLY: 200 V

# 1.4 RATINGS AND SPECIFICATIONS OF S SERIES AC SERVOMOTORS

## 1.4.1 Ratings

**Time Rating:** Continuous

**Insulation:** Class B (Types USASEM-02A□□2, -03A□□2, -05A□□2)  
Class F (Types USASEM-08A□□1, -15A□□1, -30A□□1)

**Isolation Voltage:** 1500 VAC, one minute

**Insulation Resistance:** 500 VDC, 10MΩ  
or more

**Enclosure:** Totally-enclosed, self-cooled  
(Equivalent to IP-44 exclusive shaft opening)

**Ambient Temperature:** 0 to +40°C

**Ambient Humidity:** 20% to 80%  
(non-condensing)

**Vibration:** 15μm or below

**Finish in Munsell Notation:** N1.5

**Excitation:** Permanent magnet

**Mounting:** Flange mounted

**Drive Method:** Direct drive

Table 1.4 Ratings and Specifications of S Series AC SERVOMOTORS

Motor Type USASEM- *2		02A □ 2	03A □ 2	05A □ 2	08A □ 1	15A □ 1	30A □ 1
Rated Output*	kW (HP)	0.15 (0.2)	0.31 (0.4)	0.46 (0.6)	0.77 (1.0)	1.54 (2.1)	3.08 (4.1)
Rated Torque*	N·m (lb·in)	0.49 (4.3)	0.98 (8.7)	1.47 (13)	2.45 (22)	4.90 (43)	9.81 (87)
Continuous Max Torque*	N·m (lb·in)	0.57 (5.0)	1.18 (10)	1.67 (15)	3.33 (30)	6.18 (55)	12.2 (108)
Instantaneous Peak Torque*	N·m (lb·in)	1.47 (13)	2.94 (26)	4.02 (36)	7.35 (65)	13.7 (122)	29.0 (257)
Rated Current*	A	2.1	3.0	4.2	5.3	10.4	19.9
Rated Speed*	r/min	3000					
Instantaneous Max Speed*	r/min	4000					
Torque Constant	N·m/A (lb·in/A)	0.25 (2.19)	0.35 (3.10)	0.37 (3.25)	0.51 (4.49)	0.50 (4.43)	0.53 (4.64)
Moment of Inertia J <sub>M</sub> (=GD <sup>2</sup> /4)	kg·m <sup>2</sup> ×10 <sup>-4</sup> (lb·in·s <sup>2</sup> ×10 <sup>-3</sup> )	0.13 (0.11)	0.51 (0.45)	0.75 (0.67)	2.85 (2.53)	3.25 (2.88)	5.74 (5.09)
Power Rate* <sup>1</sup>	kW/s	18.5	18.9	28.9	21	74	167
Inertia Time Constant	ms	1.8	2.2	1.8	1.9	0.7	0.4
Inductive Time Constant	ms	1.5	2.7	3.1	6.2	13	26
Insulation		Class B			Class F		

\* Values when SERVOMOTOR is combined with SERVOPACK and the armature winding temperature is 100°C. Shown are normal (TYP) values above.

† Values when SERVOMOTOR is combined with SERVOPACK and the armature winding temperature is 20°C. Shown are normal (TYP) values above.

The blank □ of motor type depends on class of detectors.

Standard: 3 (2048 pulses/rev)

Semi-Standard: 4 (2500 pulses/rev)

Optical encoder is used as a detector.

Note: The power supply units for brake:

• Input 100 VAC, Output 90 VDC: Type B9400876-2

• Input 200 VAC, Output 90 VDC: Type B9400876-1

For details, see Par.10.3 (2)

## 1.4.2 Torque-Speed Characteristics

- TYPE USASEM-02A

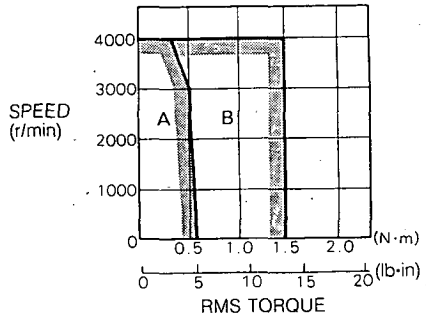

- TYPE USASEM-08A

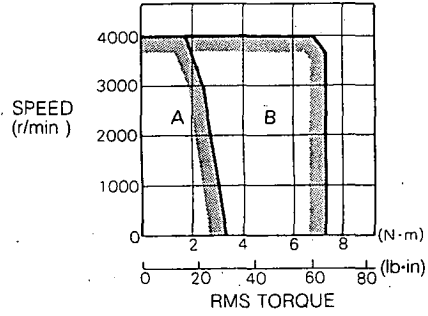

- TYPE USASEM-03A

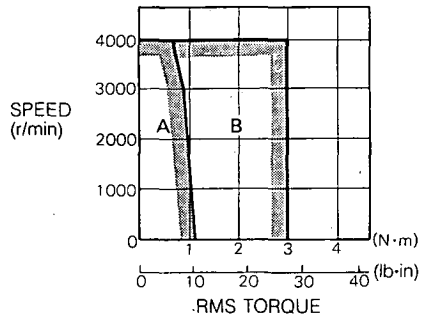

- TYPE USASEM-15A

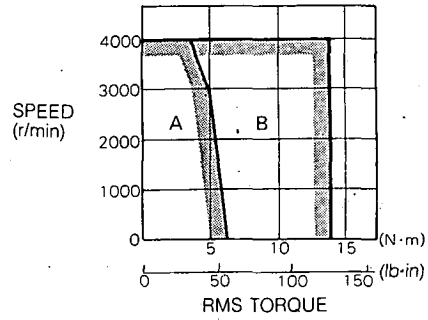

- TYPE USASEM-05A

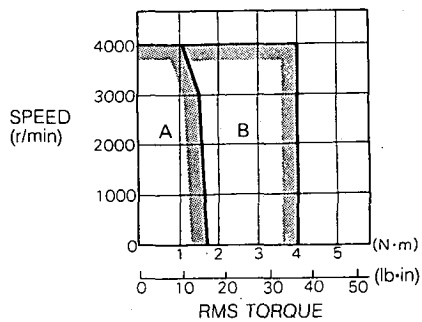

- TYPE USASEM-30A

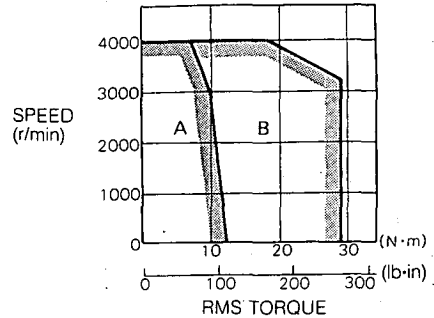

A: CONTINUOUS DUTY ZONE  
 B: INTERMITTENT DUTY ZONE  
 POWER SUPPLY: 200 V

# 1.5 RATINGS AND SPECIFICATIONS OF D SERIES AC SERVOMOTORS

## 1.5.1 Ratings

Time Rating: Continuous

Insulation: Class F

Isolation Voltage: 1500 VAC, one minute

Insulation Resistance: 500 VDC, 10MΩ  
or more

Enclosure: Totally-enclosed, self-cooled  
(Equivalent to IP-65 exclusive shaft opening)

Ambient Temperature: 0 to +40°C

Ambient Humidity: 20% to 80%  
(non-condensing)

Vibration: 15μm or below

Finish in Munsell Notation: N1.5

Excitation: Permanent magnet

Mounting: Flange mounted

Drive Method: Direct drive  
Holding Brake Provided.

Table 1.5 Ratings and Specifications of D Series AC SERVOMOTORS

Motor Type USADED- *2		05E □ 2	10E □ 2	15E □ 2	22E □ 2	37E □ 2
Rated Output*	kW (HP)	0.5 (0.67)	1.0 (1.3)	1.5 (2.0)	2.2 (2.9)	3.7 (5.0)
Rated Torque*	N·m (lb·in)	2.35 (21)	4.81 (43)	7.16 (63)	10.5 (93)	17.7 (156)
Continuous Max Torque*	N·m (lb·in)	3.43 (30)	6.37 (56)	8.83 (78)	13.7 (122)	21.6 (191)
Instantaneous Peak Torque*	N·m (lb·in)	8.24 (73)	16.9 (149)	25.1 (222)	36.8 (326)	61.8 (547)
Rated Current*	A	3.5	7.9	12.6	16.6	23.3
Rated Speed*	r/min	2000				
Instantaneous Peak Speed*	r/min	2500				
Torque Constant	N·m/A (lb·in/A)	0.83 (7.38)	0.69 (6.07)	0.64 (5.64)	0.71 (6.25)	0.82 (7.29)
Moment of Inertia J <sub>M</sub> (=GD <sup>2</sup> /4)	kg·m <sup>2</sup> ×10 <sup>-4</sup> (lb·in·s <sup>2</sup> ×10 <sup>-3</sup> )	21, 13 <sup>†</sup> (18.2, 11.3 <sup>†</sup> )	32, 24 <sup>†</sup> (28.6, 21.5 <sup>†</sup> )	62, 59 <sup>†</sup> (54.7, 52.1 <sup>†</sup> )	83, 80 <sup>†</sup> (73.8, 71.1 <sup>†</sup> )	148, 145 <sup>†</sup> (131, 128 <sup>†</sup> )
Power Rate* <sup>1</sup>	kW/s	2.7 4.4 <sup>†</sup>	7.3 9.7 <sup>†</sup>	8.2 8.6 <sup>†</sup>	13 14 <sup>†</sup>	21 22 <sup>†</sup>
Inertia Time Constant	ms	18 11 <sup>†</sup>	7.8 5.9 <sup>†</sup>	7.1 6.8 <sup>†</sup>	6.2 6.0 <sup>†</sup>	4.3 4.2 <sup>†</sup>
Inductive Time Constant	ms	4.4	6.9	9.4	11	15
Insulation		Class F				
Holding Brake	Power Supply VDC	90				
	Static Function Torque N·m (lb·in)	8.82 (78)			21.56 (191)	
Approx Mass	kg (lb)	17, 16 <sup>†</sup> (37.5, 35.3 <sup>†</sup> )	19, 18 <sup>†</sup> (41.9, 39.7 <sup>†</sup> )	30, 27 <sup>†</sup> (66.2, 59.5 <sup>†</sup> )	32, 29 <sup>†</sup> (70.6, 64 <sup>†</sup> )	39, 36 <sup>†</sup> (86.0, 79.4 <sup>†</sup> )

\* Values when SERVOMOTOR is combined with SERVOPACK and the armature winding temperature is 20°C. Shown are normal (TYP) values above.

† Values show those of D series without holding brake.

Note:

The power supply units for brake:

- Input: 100 VAC Output: 90 VDC: Type B9400876-2
- Input: 200 VAC Output: 90 VDC: Type B9400876-1

For details, refer to Par. 10.3.

The blank □ of motor type depends on class of detectors.

Standard: 2 (2048 pulses/rev)

Semi-Standard: 3 (8192 pulses/rev)

Optical encoder is used as a detector.

## 1.5.2 Torque-Speed Characteristics

- TYPE USADED-05E

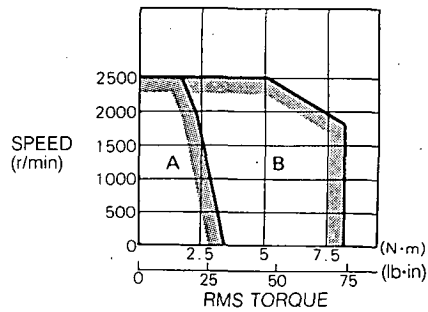

- TYPE USADED-10E

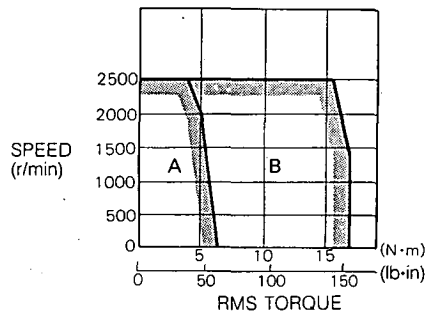

- TYPE USADED-15E

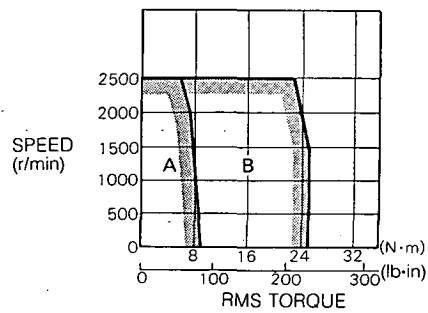

- TYPE USADED-22E

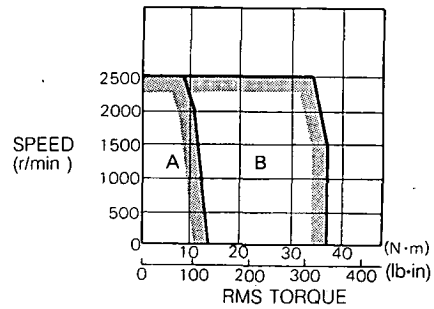

- TYPE USADED-37E

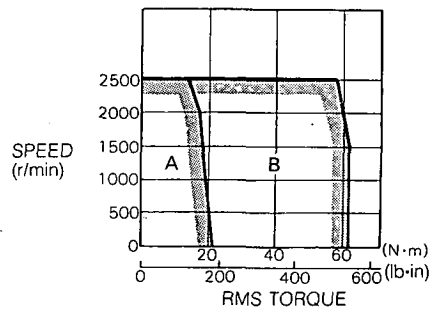

A: CONTINUOUS DUTY ZONE  
B: INTERMITTENT DUTY ZONE

# 1.6 RATINGS AND SPECIFICATIONS OF SERVOPACK

Table 1.6 SERVOPACK Types and Applicable SERVOMOTORS

SERVOPACK Type CACR-		SR02BE	SR03BE	SR05BE	SR07BE	SR10BE	SR15BE	SR20BE	SR30BE	SR44BE	SR60BE	
Max Motor Output		kW (HP)	0.2 (0.3)	0.3 (0.4)	0.5 (0.67)	0.7 (0.94)	1.0 (1.34)	1.5 (2.0)	2.0 (2.7)	3.0 (4.1)	4.4 (5.9)	6.0 (8.0)
M Series	Applicable Optical Encoder		Standard : 8192pulses/rev (Semi-Standard : 2048pulses/rev)									
	AC SERVO-MOTOR	Type USAMED-	—	03B21	—	06B21	09B22	12B22	20B22	30B22	44B22	USAMKD-60B22
		Output kW (HP)	—	0.3 (0.4)	—	0.6 (0.8)	0.9 (1.2)	1.2 (1.6)	2.0 (2.7)	3.0 (4.1)	4.4 (5.9)	6.0 (8.0)
		Rated/Max Speed r/min	1000/2000 (44B2, 60B2 : 1000/1500)									
	SERVOPACK Type CACR-		—	SR03BE12M	—	SR07BE12M	SR10BE12M	SR15BE12M	SR20BE12M	SR30BE12M	SR44BE12M	SR60BE12M
	Continuous Output Current Arms	—	3.0	—	5.8	7.6	11.7	18.8	26.0	33.0	45.0	
	Max Output Current Arms	—	7.3	—	13.9	16.6	28.0	42.0	56.6	70.0	80.6	
Allowable $J_L (=GD^2/4)$ (lb·in·s <sup>2</sup> ×10 <sup>-3</sup> )	—	67.5 (60)	—	122 (107.5)	184 (162.5)	334 (296)	550 (486)	715 (633.5)	1200 (1063)	1200 (1063)		
F Series	Applicable Optical Encoder		Standard : 8192pulses/rev (Semi-Standard : 2048pulses/rev)									
	AC SERVO-MOTOR	Type USAFED-	02D21	03D21	05C21	—	09C21	13C22	20C22	30C22	44C22	—
		Output kW (HP)	0.15 (0.2)	0.3 (0.4)	0.45 (0.6)	—	0.85 (1.1)	1.3 (1.7)	1.8 (2.4)	2.9 (3.9)	4.4 (5.9)	—
		Rated/Max Speed r/min	1500/2500									
	SERVOPACK Type CACR-		SR02BE12F	SR03BE12F	SR05BE12F	—	SR10BE12F	SR15BE12F	SR20BE12F	SR30BE12F	SR44BE12F	—
	Continuous Output Current Arms	3.0	3.0	3.8	—	6.2	9.7	15.0	20.0	30.0	—	
	Max Output Current Arms	8.5	8.5	11.0	—	17.0	27.6	42.0	56.5	77.0	—	
Allowable $J_L (=GD^2/4)$ (lb·in·s <sup>2</sup> ×10 <sup>-3</sup> )	6.5 (5.75)	10.3 (9)	67.5 (60)	—	122 (107.5)	184 (162.5)	334 (296)	550 (486)	715 (633.5)	1200 (1063)		
G Series	Applicable Optical Encoder		Standard : 8192pulses/rev (Semi-Standard : 2048pulses/rev)									
	AC SERVO-MOTOR	Type USAGED-	02C21	03C21	05A21	—	09A21	13A22	20A22	30A22	44A22	—
		Output kW (HP)	0.15 (0.2)	0.3 (0.4)	0.45 (0.6)	—	0.85 (1.1)	1.3 (1.7)	1.8 (2.4)	2.9 (3.9)	4.4 (5.9)	—
		Rated/Max Speed r/min	1500/3000									
	SERVOPACK Type CACR-		SR02BE12G	SR03BE12G	SR05BE12G	—	SR10BE12G	SR15BE12G	SR20BE12G	SR30BE12G	SR44BE12G	—
	Continuous Output Current Arms	3.0	3.0	3.8	—	7.6	11.7	19.0	26.0	33.0	—	
	Max Output Current Arms	8.5	8.5	11.0	—	17.0	—	—	—	—	—	
Allowable $J_L (=GD^2/4)$ (lb·in·s <sup>2</sup> ×10 <sup>-3</sup> )	6.5 (5.75)	10.3 (9)	67.5 (60)	—	122 (107.5)	184 (162.5)	223 (197)	393 (347)	360 (315)	—		
S Series	Applicable Optical Encoder		Standard : 2048pulses/rev (Semi-Standard : 2500pulses/rev)									
	AC SERVO-MOTOR	Type USASEM-	02A32	03A32	05A32	—	08A31	15A31	—	30A31	—	—
		Output kW (HP)	0.15 (0.2)	0.31 (0.4)	0.46 (0.6)	—	0.77 (1.0)	1.54 (2.1)	—	3.08 (4.1)	—	—
		Rated/Max Speed r/min	3000/4000									
	SERVOPACK Type CACR-		SR02BE13S	SR03BE13S	SR05BE13S	—	SR10BE13S	SR15BE13S	—	SR30BE13S	—	—
	Continuous Output Current Arms	2.1	3.0	4.2	—	5.3	10.4	—	19.9	—	—	
	Max Output Current Arms	6.0	8.5	11.0	—	15.6	28.0	—	56.5	—	—	
Allowable $J_L (=GD^2/4)$ (lb·in·s <sup>2</sup> ×10 <sup>-3</sup> )	0.65 (0.55)	2.55 (2.25)	3.8 (3.35)	—	14.3 (12.65)	16.5 (14.4)	—	28.7 (25.4)	—	—		
D Series	Applicable Optical Encoder		Standard : 2048pulses/rev (Semi-Standard : 8192pulses/rev)									
	AC SERVO-MOTOR	Type USADED-	—	—	05E32	—	—	10E32	15E32	22E32	37E32	—
		Output kW (HP)	—	—	0.5 (0.67)	—	—	10 (1.34)	1.5 (2.0)	2.2 (2.9)	3.7 (4.9)	—
		Rated/Max Speed r/min	2000/2500									
	SERVOPACK Type CACR-		—	—	SR05BE13D	—	—	SR15BE13D	SR20BE13D	SR30BE13D	SR44BE13D	—
	Continuous Output Current Arms	—	—	3.8	—	—	7.9	12.6	16.6	23.3	—	
	Max Output Current Arms	—	—	11.0	—	—	25.2	40.7	54.0	77.0	—	
Allowable $J_L (=GD^2/4)$ (lb·in·s <sup>2</sup> ×10 <sup>-3</sup> )	—	—	105 (91)	—	—	160 (143)	310 (273.5)	415 (369)	740 (655)	—		



Table 1.6 SERVOPACK Types and Applicable SERVOMOTORS (Cont'd)

SERVOPACK Type		SR02BE	SR03BE	SR05BE	SR07BE	SR10BE	SR15BE	SR20BE	SR30BE	SR44BE	SR60BE		
Max Motor Output	kW (HP)	0.2 (0.3)	0.3 (0.4)	0.5 (0.67)	0.7 (0.94)	1.0 (1.34)	1.5 (2.01)	2.0 (2.7)	3.0 (4.1)	4.4 (5.9)	6.0 (8.0)		
Power Supply	Main Circuit	Three-phase 200 to 230 VAC <sup>+10%</sup> <sub>-15%</sub> 50/60 Hz*1											
	Control Circuit	Single phase 200 to 230VAC <sup>+10%</sup> <sub>-15%</sub> 50/60 Hz*1											
Control Method		Three-phase Full-wave Rectifier Transistorized-PWM Control (Sine Wave Drive)											
Feedback		Optional encoder (8192 pulses/rev, 2048 pulses/rev)											
Ambient Temperature		0 to 55°C*5 (for type with cover : 0 to 50°C)*6											
Storage Temperature		-20°C to +85°C											
Ambient and Storage Humidity		90% or less (non-condensing)											
Vibration-resistance/Impact-resistance		5m/s <sup>2</sup> / 20m/s <sup>2</sup> (0.5G/2G)											
Mounting Structure		Base mounted											
Approx Mass		kg (lb)					6.0 (13.2)			7.0 (15.4)		13.5 (29.8)	
SERVOPACK	Basic Specifications	Speed Control Range*2		1 : 5000									
		Speed Control	Load Regulation 0 to 100%	+0.01% or less at rated r/min									
			Speed*3 Regulation ±10%	0%									
			Temp. Regulation 25 ± 25°C	±0.1% or less at rated r/min									
		Frequency Response Characteristics		100 Hz (JL=JM)									
SERVOPACK	I/O Signals	Speed Reference Input	Rated Reference Voltage	Speed Control Mode	±6 VDC at rated r/min (forward run at plus reference)								
				Torque Control Mode	±3 VDC at rated torque (forward torque generated at plus reference)								
			Input Impedance	Approx 30kΩ									
			Circuit Time Constant	Approx 70μs									
		Auxiliary Reference Input*4	Reference Voltage	±12 VDC at rated r/min (forward run at puls reference)									
			Input Impedance	Approx 30kΩ									
			Circuit Time Constant	Approx 70μs									
		Built-in Reference Power Supply		±12 VDC ±5%, ±30mA Output-able									
		Position Output (PG Pulse)	Output Form	Line Driver and Open Collector (A-phase, B-phase, C-phase)									
			Dividing Ratio	(1 to N)/N, N=8192, 2048 (by number of optical encoder pulse)									
Sequence Input Signal		Servo ON, P drive (or torque control zero-clamp drive), F overtravel, R overtravel, alarm reset											
Sequence Output Signal		Servo ready, TG ON, current limit, servo alarm, alarm code (3-bit output)											
External Current Limit		0 to max current in each of P and N (3V/100% current)											
Dynamic Brake		Operated at main power OFF, servo alarm, overtravel, etc.											
Regeneration		Provided (for type SR60BE, separately provided)											
Applicable Load Inertia J <sub>L</sub>		Up to 2 to 5 times motor inertia*7											
Overtravel Prevention		DB stop or deceleration stop											
Protection		Communication error, overcurrent(OC), MCCB trip(MCCB), regenerative error(RG), undervoltage (UV), overspeed overvoltage(OV), overload(OL), origin error, overrun, open phase detection, CPU error(CPU, A/D)											
Indication		7-segment LEDs x 5 figures (Alarm, status, parameter indications)											
Monitor Output		Speed monitor : 2V (4V) ±5%/1000r/min, Torque monitor : 3V (2V) ±10%/100%											
Other functions		Torque control, zero clamp, soft start, brake interlock, reverse turn connection, JOG Operate*8											

\*1. Supply voltage should not exceed 230 V + 10% (253 V). If the voltage should exceed this value, a step down transformer is required.

\*2. In the speed control range, the lowest speed is defined as the condition in which there is 100% load variation, but not stopped.

\*3. Speed regulation is generally defined as follows:

$$\text{Speed regulation} = \frac{\text{No load speed} - \text{Rated speed}}{\text{Rated speed}} \times 100 (\%)$$

Motor speed may be changed by voltage variation or operational amplifier drift due to temperature. The ratio of this speed change to the rated speed represents the speed regulation due to voltage or temperature change.

\*4. Used for application at rated reference voltage other than ±6V.

\*5. When housed in a panel, the inside temperature must not exceed ambient temperature range.

\*6. Type with cover: CACR-SR03BE1□□□□-C

\*7. When load J<sub>L</sub> exceeds applicable range, be sure to refer to 6.7.2., "Load Inertia."

\*8. JOG operation with monitor switch

## 2. TYPE DESIGNATION

### • AC SERVOMOTOR

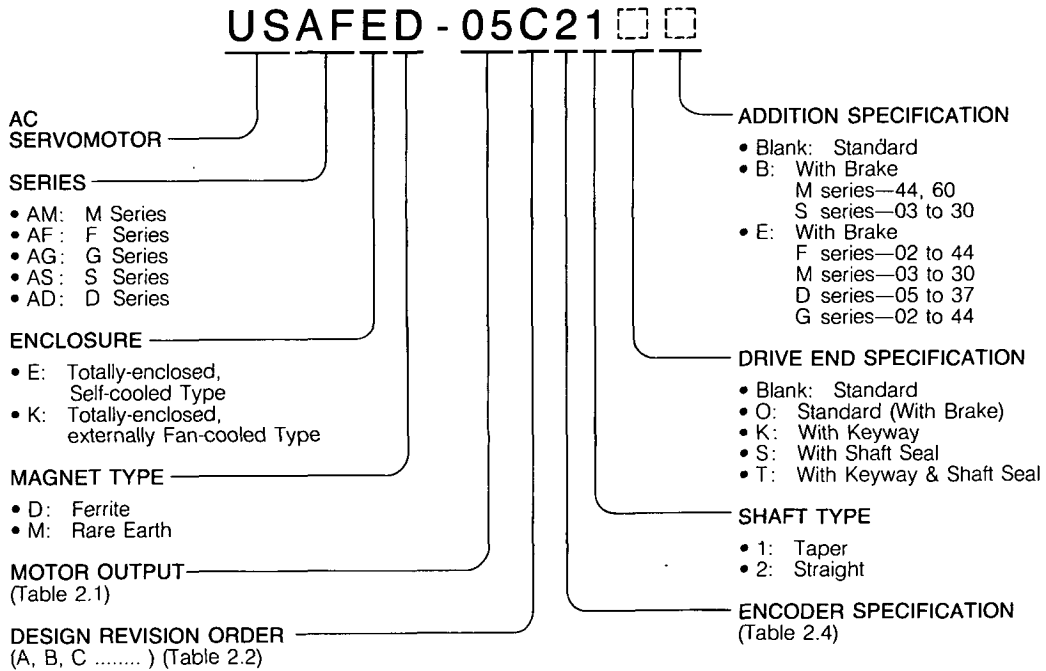

### • SERVOPACK

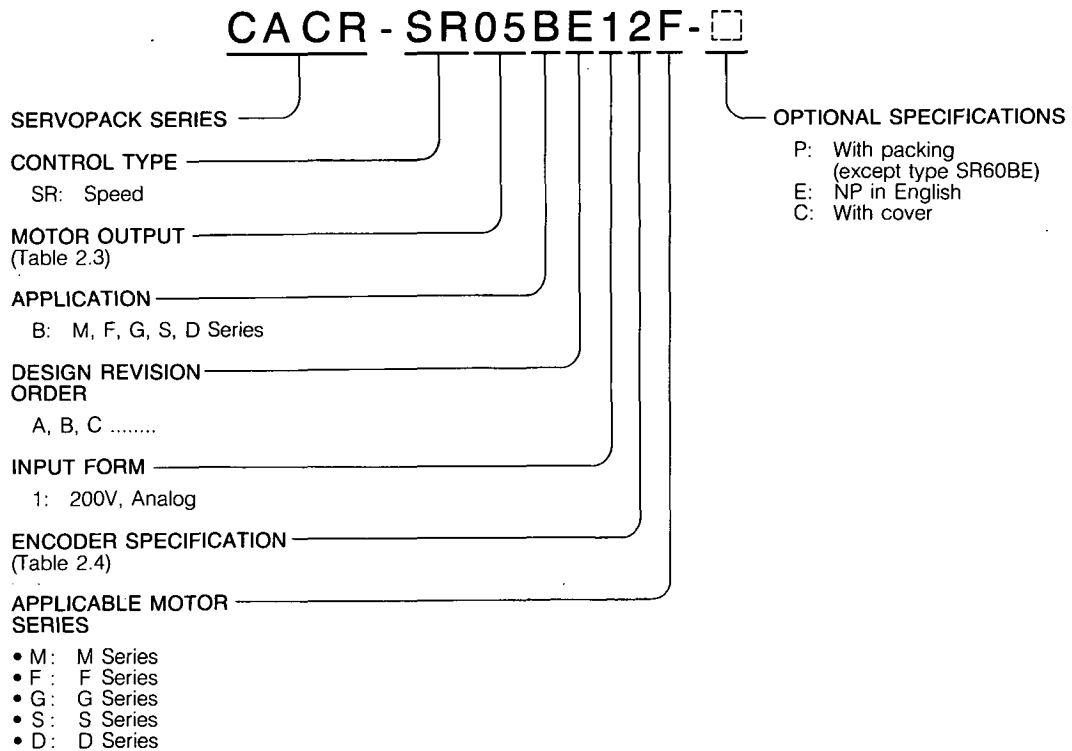

Table 2.1

	Motor Output				
	M Series	F Series	G Series	S Series	D Series
02	—	0.15kW(0.2HP)	0.15kW(0.2HP)	0.15kW(0.2HP)	—
03	0.3kW(0.4HP)	0.3kW(0.4HP)	0.3kW(0.4HP)	0.31kW(0.4HP)	—
05	—	0.45kW(0.6HP)	0.45kW(0.6HP)	0.46kW(0.6HP)	0.5kW(0.67HP)
06	0.6kW(0.8HP)	—	—	—	—
08	—	—	—	0.77kW(10HP)	—
09	0.9kW(1.2HP)	0.85kW(1.1HP)	0.85kW(1.1HP)	—	—
10	—	—	—	—	1.0kW(1.3HP)
12	1.2kW(1.6HP)	—	—	—	—
13	—	1.3kW(1.7HP)	1.3kW(1.7HP)	—	—
15	—	—	—	1.54kW(2.1HP)	1.5kW(2.0HP)
20	2.0kW(2.7HP)	1.8kW(2.4HP)	1.8kW(2.4HP)	—	—
22	—	—	—	—	2.2kW(2.9HP)
30	3.0kW(4.1HP)	2.9kW(3.9HP)	2.9kW(3.9HP)	3.08kW(4.1HP)	—
37	—	—	—	—	3.7kW(5.0HP)
44	4.4kW(5.9HP)	4.4kW(5.9HP)	4.4kW(5.9HP)	—	—
60	6.0kW(8.0HP)	—	—	—	—

Table 2.2

Encoder Resolution (P/R)	Series	Type	Encoder Resolution (P/R)	Series	Type		
2048 P/R	M	USAMED-03C3 -06C3 -09B3 to USAMKD-60B3	8192 P/R	M	USAMED-03B2 to USAMKD-60B2		
		F			USAFED-02D3 to -09D3 -13C3 to -44C3	F	USAFED-02D2 -03D2 -05C2 to -44C2
					G		USAGED-02C3 to -09C3 -13A3 to -44A3
	S	USASEM-02A3 to -30A3		D		USADED-05E2 to -37E2	
	D	USADED-05E3 to -37E3	2500 P/R		S	USASEM-02A4 to -30A4	

Table 2.3

	Motor Output				
	M series	F series	G series	S series	D series
02	—	0.15kW(0.2HP)	0.15kW(0.2HP)	0.15kW(0.2HP)	—
03	0.3kW(0.4HP)	0.3kW(0.4HP)	0.3kW(0.4HP)	0.3kW(0.4HP)	—
05	—	0.45kW(0.6HP)	0.45kW(0.6HP)	0.45kW(0.6HP)	0.5kW(0.67HP)
07	0.6kW(0.8HP)	—	—	—	—
10	0.9kW(1.2HP)	0.85kW(1.1HP)	0.85kW(1.1HP)	0.77kW(10HP)	—
15	1.2kW(1.6HP)	1.3kW(1.7HP)	1.3kW(1.7HP)	1.54kW(2.1HP)	1.0kW(1.3HP)
20	2.0kW(2.7HP)	1.8kW(2.4HP)	1.8kW(2.4HP)	—	1.5kW(2.0HP)
30	3.0kW(4.1HP)	2.9kW(3.9HP)	2.9kW(3.9HP)	3.08kW(4.1HP)	2.2kW(2.9HP)
44	4.4kW(5.9HP)	4.4kW(5.9HP)	4.4kW(5.9HP)	—	3.7kW(5.0HP)
60	6.0kW(8.0HP)	—	—	—	—



Table 2.4

Motor Type	Standard (P/R)		Semi-standard (P/R)	
M Series	2	8192	3	2048
F Series	2	8192	3	2048
G Series	2	8192	3	2048
S Series	3	2048	4	2500
D Series	3	2048	2	8192

### 3. LIST OF STANDARD COMBINATION



#### Combination of SERVOPACK, AC SERVOMOTORS and Accessories

• **M SERIES**  
(Table 3.1)



SERVOPACK Type CACR-	AC SERVOMOTOR Type	Power Capacity*1 per SERVOPACK kVA	Current Capacity per MCCB or Fuse A	Applicable Noise Filter
SR 03 BE 12M	USAMED-03 B 21	0.65	5	 Good
SR 07 BE 12M	USAMED-06 B 21	1.5	8	
SR 10 BE 12M	USAMED-09 B 22	2.1	8	
SR 15 BE 12M	USAMED-12 B 22	3.1	10	
SR 20 BE 12M	USAMED-20 B 22	4.1	12	
SR 30 BE 12M	USAMED-30 B 22	6.0	18	
SR 44 BE 12M	USAMED-44 B 22	8.0	24	
SR 60 BE 12M*3	USAMKD-60 B 22	11	32	 Poor

\*1: Values at rated load. \*2: Made by Tokin Corp. \*3: For type CACR-SR60BE, regenerative register unit (JUSP-RA03) is required.

• **F SERIES**  
(Table 3.2)

SERVOPACK Type CACR-	AC SERVOMOTOR Type	Power Capacity per SERVOPACK kVA	Current Capacity per MCCB or Fuse A	Applicable Noise Filter
SR 02 BE 12 F	USAFED-02 D 21	0.65	5	 Good
SR 03 BE 12 F	USAFED-03 D 21		5	
SR 05 BE 12 F	USAFED-05 C 21	1.1	8	
SR 10 BE 12 F	USAFED-09 C 21	2.1	10	
SR 15 BE 12 F	USAFED-13 C 22	3.1	12	
SR 20 BE 12 F	USAFED-20 C 22	4.1	18	
SR 30 BE 12 F	USAFED-30 C 22	6.0	24	
SR 44 BE 12 F	USAFED-44 C 22	8.0	24	 Poor



• **G SERIES**  
(Table 3.3)

SERVOPACK Type CACR-	AC SERVOMOTOR Type	Power Capacity per SERVOPACK kVA	Current Capacity per MCCB or Fuse A	Applicable Noise Filter
SR 02 BE 12 G	USAGED-02 C 21	0.65	5	 Good
SR 03 BE 12 G	USAGED-03 C 21		5	
SR 05 BE 12 G	USAGED-05 A 21	1.1	8	
SR 10 BE 12 G	USAGED-09 A 21	2.1	10	
SR 15 BE 12 G	USAGED-13 A 22	3.1	12	
SR 20 BE 12 G	USAGED-20 A 22	4.1	18	
SR 30 BE 12 G	USAGED-30 A 22	6.0	24	
SR 44 BE 12 G	USAGED-44 A 22	8.0	24	 Poor

• **S SERIES**  
(Table 3.4)

SERVOPACK Type CACR-	AC SERVOMOTOR Type	Power Capacity per SERVOPACK kVA	Current Capacity per MCCB or Fuse A	Applicable Noise Filter
SR 02 BE 13 S	USASEM-02 A 32	0.65	5	 Good
SR 03 BE 13 S	USASEM-03 A 32		5	
SR 05 BE 13 S	USASEM-05 A 32	1.1	8	
SR 10 BE 13 S	USASEM-08 A 31	2.1	10	
SR 15 BE 13 S	USASEM-15 A 31	3.1	12	
SR 30 BE 13 S	USASEM-30 A 31	6.0	18	

• **D SERIES**  
(Table 3.5)

SERVOPACK Type CACR-	AC SERVOMOTOR Type	Power Capacity per SERVOPACK kVA	Current Capacity per MCCB or Fuse A	Applicable Noise Filter
SR 05 BE 13 D	USADED-05 E 32	1.5	8	 Good
SR 15 BE 13 D	USADED-10 E 32	3.1	10	
SR 20 BE 13 D	USADED-15 E 32	4.1	12	
SR 30 BE 13 D	USADED-22 E 32	6.0	18	
SR 44 BE 13 D	USADED-37 E 32	8.0	24	
				 Poor

Recommended Noise Filter*2		Power ON/OFF Switch
Type	Specifications	
LF-305	3-phase 200 VAC class, 5A	Contactor 30A or above
LF-310	3-phase 200 VAC class, 10A	
LF-315	3-phase 200 VAC class, 15A	
LF-315	3-phase 200 VAC class, 15A	
LF-320	3-phase 200 VAC class, 20A	Contactor 35A or above
LF-330	3-phase 200 VAC class, 30A	
LF-340	3-phase 200 VAC class, 40A	
LF-350	3-phase 200 VAC class, 50A	Contactor 50A or above

Recommended Noise Filter		Power ON/OFF Switch
Type	Specifications	
LF-305	3-phase 200 VAC class, 5 A	Contactor 30A or above
LF-305	3-phase 200 VAC class, 5 A	
LF-305	3-phase 200 VAC class, 5 A	
LF-315	3-phase 200 VAC class, 15 A	
LF-315	3-phase 200 VAC class, 15 A	
LF-320	3-phase 200 VAC class, 20 A	
LF-330	3-phase 200 VAC class, 30 A	Contactor 35A or above
LF-340	3-phase 200 VAC class, 40 A	

Recommended Noise Filter		Power ON/OFF Switch
Type	Specifications	
LF-305	3-phase 200 VAC class, 5 A	Contactor 30A or above
LF-305	3-phase 200 VAC class, 5 A	
LF-305	3-phase 200 VAC class, 5 A	
LF-315	3-phase 200 VAC class, 15 A	
LF-315	3-phase 200 VAC class, 15 A	
LF-320	3-phase 200 VAC class, 20 A	Contactor 35A or above
LF-330	3-phase 200 VAC class, 30 A	
LF-340	3-phase 200 VAC class, 40 A	

Recommended Noise Filter		Power ON/OFF Switch
Type	Specifications	
LF-305	3-phase 200 VAC class, 5 A	Contactor 30A or above
LF-305	3-phase 200 VAC class, 5 A	
LF-305	3-phase 200 VAC class, 5 A	
LF-315	3-phase 200 VAC class, 15 A	
LF-315	3-phase 200 VAC class, 15 A	
LF-330	3-phase 200 VAC class, 30 A	Contactor 35A or above

Recommended Noise Filter		Power ON/OFF Switch
Type	Specifications	
LF-310	3-phase 200 VAC class, 10 A	Contactor 30A or above
LF-315	3-phase 200 VAC class, 15 A	
LF-320	3-phase 200 VAC class, 20 A	Contactor 35A or above
LF-330	3-phase 200 VAC class, 30 A	
LF-340	3-phase 200 VAC class, 40 A	

Specifications of AC SERVOMOTORS, Detectors and Holding Brakes for Connection

• M SERIES  
(Table 3.6)

AC SERVOMOTOR					Detector		
Type	Receptacle Type	L-type Plug	Straight Plug	Cable Clamp	Receptacle Type	L-type Plug	
USAMED-03□□1	MS3102A 18-10P	MS3108B 18-10S	MS3106B 18-10S	MS3057 -10A	MS3102 20-29P	MS3108B 20-29S	
USAMED-06□□1							
USAMED-09B□□2							
USAMED-12B□□2	MS3102A 22-22P	MS3108B 22-22S	MS3106B 22-22S	MS3057 -12A			
USAMED-20B□□2							
USAMED-30B□□2							
USAMED-44B□□2	MS3102A 32-17P	MS3108B 32-17S	MS3106B 32-17S	MS3057 -20A			
USAMKD-60B□□2*							

• F SERIES  
(Table 3.7)

AC SERVOMOTOR					Detector		
Type	Receptacle Type	L-type Plug	Straight Plug	Cable Clamp	Receptacle Type	L-type Plug	
USAFED-02□□□1	MS3102A 14S-2P	MS3108B 14S-2S	MS3106B 14S-2S	MS3057 6A	MS3102A 20-29P	MS3108B 20-29S	
USAFED-03□□□1							
USAFED-05□□□1	MS3102A 18-10P	MS3108B 18-10S	MS3106B 18-10S	MS3057 -10A			
USAFED-09□□□1							
USAFED-13C□□2							
USAFED-20C□□2	MS3102A 22-22P	MS3108B 22-22S	MS3106B 22-22S	MS3057 -12A			
USAFED-30C□□2							
USAFED-44C□□2							

• G SERIES  
(Table 3.8)

AC SERVOMOTOR					Detector		
Type	Receptacle Type	L-type Plug	Straight Plug	Cable Clamp	Receptacle Type	L-type Plug	
USAGED-02□□□1	MS3102A 14S-2P	MS3108B 14S-2S	MS3106B 14S-2S	MS3057 6A	MS3102A 20-29P	MS3108B 20-29S	
USAGED-03□□□1							
USAGED-05□□□1	MS3102A 18-10P	MS3108B 18-10S	MS3106B 18-10S	MS3057 -10A			
USAGED-09□□□1							
USAGED-13A□□2							
USAGED-20A□□2	MS3102A 22-22P	MS3108B 22-22S	MS3106B 22-22S	MS3057 -12A			
USAGED-30A□□2							
USAGED-44A□□2							

• S SERIES  
(Table 3.9)

AC SERVOMOTOR				Detector		
Type	Receptacle Type	L-type Plug	Cable Clamp	Receptacle Type	L-type Plug	Cable Clamp
USASEM-02A□□2	—	—	—	MS3102A 20-29P	MS3108B 20-29S	MS3057 -12A
USASEM-03A□□2	MS3102A 18-10P	MS3108B 18-10S	MS3057 -10A			
USASEM-05A□□2						
USASEM-08A□□2	MS3102A 20-4P	MS3108B 20-4S	MS3057 -12A			
USASEM-15A□□2						
USASEM-30A□□2						

• D SERIES  
(Table 3.10)

AC SERVOMOTOR					Detector		
Type	Receptacle Type	L-type Plug	Straight Plug	Cable Clamp	Receptacle Type	L-type Plug	
USADED-05E□□2	MS3102A 20-15P	MS3108B 20-15S	MS3106B 20-15S	MS3057 -12A	MS3102A 20-29P	MS3108B 20-29S	
USADED-10E□□2							
USADED-15E□□2	MS3102A 24-10P	MS3108B 24-10S	MS3106B 24-10S	MS3057 -16A			
USADED-22E□□2							
USADED-37E□□2							

		Holding Brake				
	Straight Plug	Cable Clamp	Receptacle Type	L-type Plug	Straight Plug	Cable Clamp
	MS3106B 20-29S	MS3057 -12A	MS3102A 20-15P	MS3108B 20-15S	MS3106B 20-15S	MS3057 -12A
			MS3102A 24-10P	MS3108B 24-10S	MS3106B 24-10S	MS3057 -16A
			MS3102A32-17P MS3102A14S-7P	MS3108B32-17S MS3108B14S-7S	MS3106B32-17S MS3106B14S-7S	MS3057-20A MS3057-6A

		Holding Brake				
	Straight Plug	Cable Clamp	Receptacle Type	L-type Plug	Straight Plug	Cable Clamp
	MS3106B 20-29S	MS3057 -12A	MS3102A 14S-6P	MS3108B 14S-6S	MS3106B 14S-6S	MS3057 -6A
			MSA3102A 20-15P	MS3108B 20-15S	MS3106B 20-15S	MS3057 -12A
			MS3102A 24-10P	MS3108B 24-10S	MS3106B 24-10S	MS3057 -16A

		Holding Brake				
	Straight Plug	Cable Clamp	Receptacle Type	L-type Plug	Straight Plug	Cable Clamp
	MS3106B 20-29S	MS3057 -12A	MS3102A 14S-6P	MS3108B 14S-6S	MS3106B 14S-6S	MS3057 -6A
			MSA3102A 20-15P	MS3108B 20-15S	MS3106B 20-15S	MS3057 -12A
			MS3102A 24-10P	MS3108B 24-10S	MS3106B 24-10S	MS3057 -16A

Holding Brake			
	Receptacle Type	L-type Plug	Cable Clamp
	—	—	—
	MS3102A 18-12P	MS3108B 18-12S	MS3057 -10A
	MS3102A 20-17P	MS3108B 20-17S	MS3057 -12A

\*For type USAMKD-60B□2, the followings are required for cooling fan:

Receptacle type: MS3102A14S-6P

L-type plug: MS3108B14S-6S

Straight plug: MS3106B14S-6S

Cable clamp: MS3057-6A

Notes:

1. The blank □ of motor type depends on class of detectors.

Motor Type	Standard (P/R)		Semi-standard (P/R)	
	M Series	2	8192	3
F Series	2	8192	3	2048
G Series	2	8192	3	2048
S Series	3	2048	4	2500
D Series	3	1024	2	8192

	Straight Plug	Cable Clamp
	MS3106B 20-29S	MS3057 -12A

2. When plugs or clamps are required, contact your YASKAWA representative. The following connections are provided: soldered type (type MS) and solderless type (type JA).

## 4. CHARACTERISTICS

### 4.1 OVERLOAD CHARACTERISTICS

The overload protective circuit built in SERVOPACK prevents the motor and SERVOPACK from overloading and restricts the allowable conduction time of SERVOPACK. (See Fig. 4.1.)

The overload detection level is set precisely by the hot start conditions at an ambient temperature of 55°C and cannot be changed.

#### NOTE

Hot start is the overload characteristics when the SERVOPACK is running at the rated load and thermally saturated.

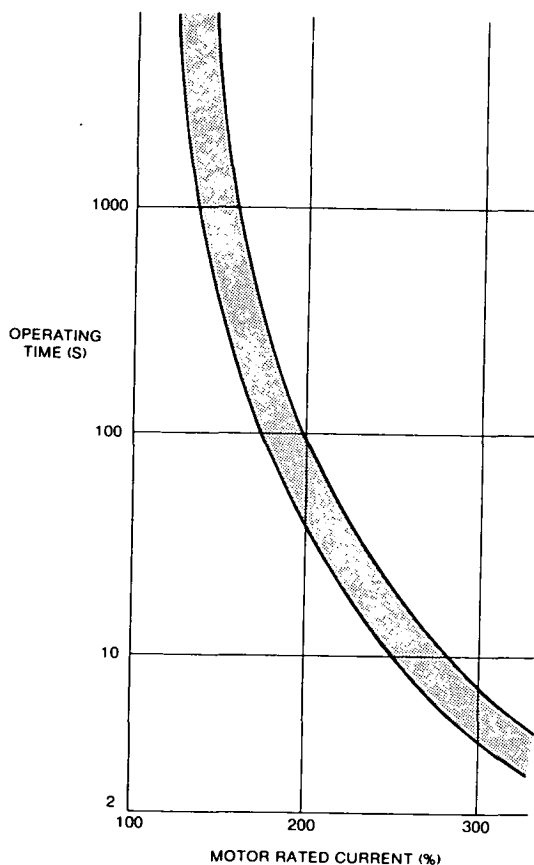

Fig. 4.1 Allowable Overload Curve of SERVOPACK



## 4.2 STARTING AND STOPPING TIME

The starting time and stopping time of servomotor under a constant load is shown by the formula below. Viscous or friction torque of the motor is disregarded.

Starting Time:

$$t_r = 104.7 \times \frac{N_R (J_M + J_L)}{K_t \cdot I_R (\alpha - \beta)} \quad (ms)$$

Stopping Time:

$$t_f = 104.7 \times \frac{N_R (J_M + J_L)}{K_t \cdot I_R (\alpha + \beta)} \quad (ms)$$

Where,

$N_R$ : Rated motor speed (r/min)

$J_M (= GD_M^2/4)$ : Moment of rotor inertia ( $kg \cdot m^2$ )

$J_L (= GD_L^2/4)$ : Moment of load inertia ( $kg \cdot m^2$ )

$K_t$ : Torque constant of motor (N·m/A)

$I_R$ : Motor rated current (A)

=  $I_p/I_R$ : Acceleration/deceleration current constant

$I_p$ : Acceleration/deceleration current

(Acceleration/deceleration current  $\alpha$  times the motor rated current) (A)

=  $I_L/I_R$ : Load current constant

$I_L$ : Current equivalent to load torque

(Load current  $\beta$  times the motor rated current) (A)

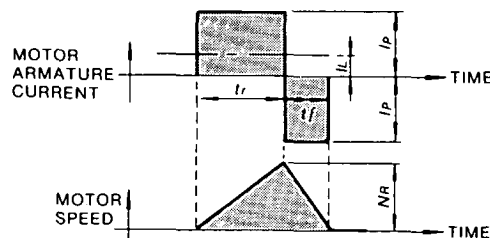

Fig. 4.2 Timing Chart of Motor Armature Current and Speed

### 4.3 ALLOWABLE FREQUENCY OF OPERATION

The allowable frequency of operation is restricted by the SERVOMOTOR and SERVOPACK, and both the conditions must be considered for satisfactory operation.

- Allowable frequency of operation restricted by the SERVOPACK

The allowable frequency of operation is restricted by the heat generated in the regenerative resistor in the Servopack, and varies depending on the motor types, capacity, load  $J$  ( $J_L$ ), acceleration/deceleration current values, and motor speed. If the frequency of operation exceeds 60 times/min when load  $J = 0$  before the rated speed is reached, or if it exceeds  $\frac{60}{m+1}$  cycles/min when  $J_L = J_M \times m$ , contact your YASKAWA representative.

- Allowable frequency of operation restricted by the SERVOMOTOR

The allowable frequency of operation varies depending on the load conditions, motor running time and the operating conditions. Typical examples are shown below.

See Par.4.2, "STARTING AND STOPPING TIME" for symbols.

- When the motor repeats rated-speed operation and being at standstill (Fig.4.3).

Cycle time ( $T$ ) should be determined so that RMS value of motor armature current is lower than the motor rated current:

$$T \geq \frac{I_p^2 (tr + tf) + I_L^2 ts}{I^2_R} \text{ (s)}$$

Where cycle time ( $T$ ) is determined, values  $I_p$ ,  $tr$ ,  $tf$  satisfying the formula above, should be specified.

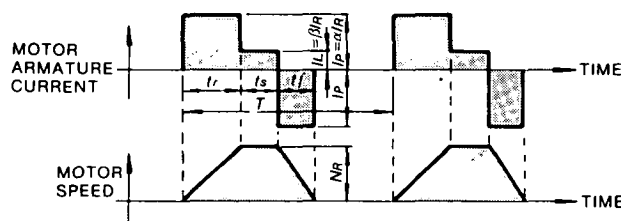

Fig. 4.3 Timing Chart of Motor Armature Current and Speed

- When the motor remains at standstill between cycles of acceleration and deceleration without continuous rated speed running (Fig. 4.4).

The timing chart of the motor armature current and speed is as shown in Fig. 4.4. The allowable frequency of operation "n" can be calculated as follows:

$$n = 286.5 \times \frac{K_t \cdot I_R}{N_R (J_M + J_L)} \times \frac{1}{\alpha} - \frac{\beta^2}{\alpha^3} \quad (\text{times/min})$$

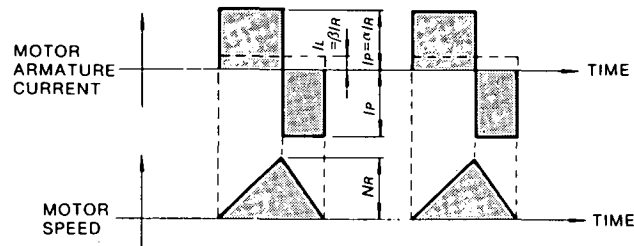

Fig. 4.4 Timing Chart of Motor Armature Current and Speed

- When the motor accelerates, runs at constant speed, and decelerates in a continuing cycle without being at standstill (Fig. 4.5).

The timing chart of the motor armature current and speed is as shown in Fig. 4.5. The allowable frequency of operation "n" can be calculated as follows.

$$n = 286.5 \times \frac{K_t \cdot I_R}{(J_M + J_L)} \times \frac{1}{\alpha} - \frac{\beta^2}{\alpha} \quad (\text{times/min})$$

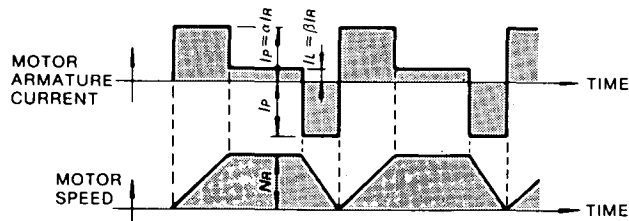

Fig. 4.5 Timing Chart of Motor Armature Current and Speed

## 4.4 SERVO MOTOR FREQUENCY

In the servo drive consisting of SERVOPACK and SERVOMOTOR, motor speed amplitude is restricted by the maximum armature current controlled by SERVOPACK.

The relation between motor speed amplitude (N) and frequency (f) is shown by the formula below:

$$N = 1.52 \times \frac{\alpha \cdot K_t \cdot I_R}{(J_M + J_L) f} \quad (\text{r/min})$$

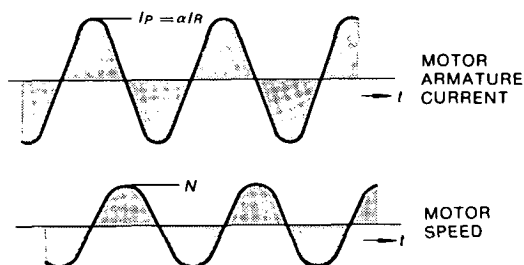

Fig. 4.6 Timing Chart of Motor Armature Current and Speed

## 4.5 MOTOR SPEED-REFERENCE INPUT CHARACTERISTICS

Fig. 4.7 shows motor speed and input voltage curve when speed reference input terminals 1CN-⑫ and ⑬ are used. With auxiliary input terminals, 1CN-⑭ and ⑮, motor speed can be set to the rating by adjusting user constant Cn-03  $\boxed{\text{INBGN}}$  as long as input voltage is within  $\pm 2\text{V}$  to  $\pm 10\text{V}$ . See Fig. 4.8.

The forward motor rotation (+) means counterclockwise (CCW) rotation when viewed from the drive end.

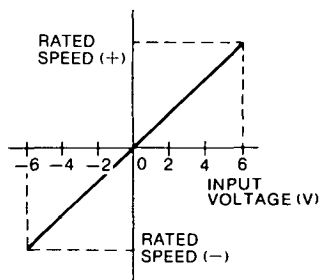

Fig. 4.7 Speed-Input Voltage Characteristics

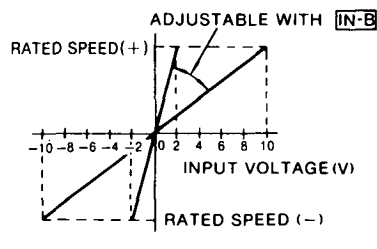

Fig. 4.8 Speed-Input Voltage Characteristics when Auxiliary Input Terminals 1CN-⑭ and ⑮ are used.

## 4.6 MOTOR MECHANICAL CHARACTERISTICS

### 4.6.1 Mechanical Strength

AC SERVOMOTORS can carry up to 300% of the rated momentary maximum torque at output shaft. (D series up to 350%)

### 4.6.2 Allowable Radial Load and Thrust Load

Table 4.1 to 4.5 show allowable loads according to AC SERVOMOTOR types.

Table 4.1 M Series Allowable Radial Load and Thrust Load

Motor Type USAMED-	Allowable Radial Load* N (lb)	Allowable Thrust Load N (lb)
03□□1	490 (110)	98 ( 22)†
06□□1	490 (110)	98 ( 22)†
09B□2	686 (154)	343 ( 77)
12B□2	1470 (330)	490 (110)
20B□2	1470 (330)	490 (110)
30B□2	1470 (330)	490 (110)
44B□2	1764 (397)	588 (132)
USAMKD-60B□2	1764 (397)	588 (132)

Table 4.2 F Series Allowable Radial Load and Thrust Load

Motor Type USAFED-	Allowable Radial Load* N (lb)	Allowable Thrust Load N (lb)
02□□1	147 ( 33)	49 ( 11)†
03□□1	147 ( 33)	49 ( 11)†
05□□1	490 (110)	98 ( 22)†
09□□1	490 (110)	98 ( 22)†
13C□2	686 (154)	343 ( 77)
20C□2	1470 (331)	490 (110)
30C□2	1470 (331)	490 (110)
44C□2	1470 (331)	490 (110)

Table 4.3 G Series Allowable Radial Load and Thrust Load

Motor Type USAGED-	Allowable Radial Load* N (lb)	Allowable Thrust Load N (lb)
02□□1	147 ( 33)	49 ( 11)
03□□1	147 ( 33)	49 ( 11)
05□□1	490 (110)	98 ( 22)
09□□1	490 (110)	98 ( 22)
13A□2	686 (154)	343 ( 77)
20A□2	1470 (331)	490 (110)
30A□2	1470 (331)	490 (110)
44A□2	1470 (331)	490 (110)

Table 4.4 S Series Allowable Radial Load and Thrust Load

Motor Type USASEM-	Allowable Radial Load* N (lb)	Allowable Thrust Load N (lb)
02A□2	78.4 ( 18)	39.2 ( 9)
03A□2	245 ( 55)	98 (22)
05A□2	245 ( 55)	98 (22)
08A□1	392 ( 88)	147 (33)
15A□1	490 (110)	147 (33)
30A□1	686 (154)	196 (44)

Table 4.5 D Series Allowable Radial Load and Thrust Load

Motor Type USADED-	Allowable Radial Load* N (lb)	Allowable Thrust Load N (lb)
05E□2	686 (154)	343 ( 77)
10E□2	686 (154)	343 ( 77)
15E□2	1176 (265)	490 (110)
22E□2	1176 (265)	490 (110)
37E□2	1176 (265)	490 (110)

\* Maximum values of the load applied to the shaft extension.

† Do not apply the exceeding load because motor cannot be rotated.

### 4.6.3 Mechanical Specifications

Table 4.6 Mechanical Specifications in mm

Accuracy (T.I.R.)†		Reference Diagram
Flange surface perpendicular to shaft (A)	0.04 (0.06)‡	
Flange diameter concentric to shaft (B)	0.04	
Shaft run out (C)	0.02 (0.04)*	

† T.I.R. (Total Indicator Reading)

‡ Accuracy for motor types USADED-15E, -22E, and -37E.

\* Accuracy for motor types USAMED-44B, USAMKD-60B.

### 4.6.4 Direction of Rotation

AC SERVOMOTORS rotate counterclockwise (CCW) when viewed from the drive end when motor and detector leads are connected as shown below.

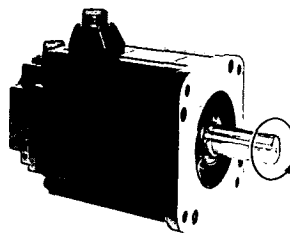
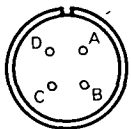

Fig. 4.9 AC SERVOMOTOR

#### (1) Connector Specifications for Standard SERVOMOTORS

##### (a) Motor receptacle

- M, F, G, D Series



A	Phase U
B	Phase V
C	Phase W
D	Frame ground

- S Series

(Type USASEM-02A)

Color of Lead	Applicable
Red	Phase U
White	Phase V
Blue	Phase W
Green	Frame ground

(Types USASEM-03A to 30A)

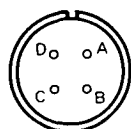

A	Phase U
B	Phase V
C	Phase W
D	Frame ground

##### (b) Detector receptacle

- M, F, G, S, D Series

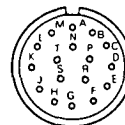

A	Channel A output	K	—
B	Channel $\bar{A}$ output	L	—
C	Channel B output	M	—
D	Channel $\bar{B}$ output	N	—
E	Channel C output	P	—
F	Channel $\bar{C}$ output	R	—
G	0 V	S	—
H	+ 5 VDC	T	—
J	Frame ground	—	—

(2) Connector Specifications for SERVOMOTOR with Brake

- M, F (except types USAFEM-02, -03), G, D Series (Brake is provided to all types of D series as standard.)

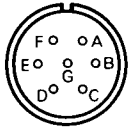

A	Phase-U	E	Brake terminal
B	Phase-V	F	
C	Phase-W	G	—
D	Frame ground		

- F Series (Types USAFEM-02, -03)

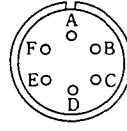

A	Phase-U	E	Brake terminal
B	Phase-V	F	Brake terminal
C	Phase-W		
D	Frame ground		

Types without brake of D series do not use E and F.

- S Series (Type USASEM-02A)

Color of Lead	Applicable
Red	Phase U
White	Phase V
Blue	Phase W
Black	Brake terminal
Black	
Green	Frame ground

- (Types USASEM-03A, -05A)

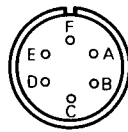

A	Phase U
B	Phase V
C	Phase W
D	Brake terminal
E	
F	Frame ground

- (Types USASEM-08A to 30A)

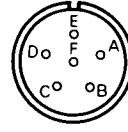

A	Phase U
B	Phase V
C	Phase W
D	Brake terminal
E	
F	Frame ground

- Fan terminal connector specifications (Type USAMKD-60B□2)

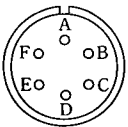

A	Fan motor
B	Fan motor
C	—
D	Alarm terminal
E	Alarm terminal
F	—

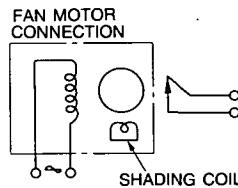

Power Supply: Single-phase 200/200/220V, 50/60/60Hz

Alarm Contact: OFF when fan is running normally ON when fan rotation is  $1800 \pm 200$  r/min or less. When cooling fan starts running, ON for 3 seconds.

Contact Capacity: Resistance load is 110V max, 0.3A

Fig. 4.10 Fan Terminal Connection

Arrange the main circuit sequence to stop the SERVOMOTOR and fan motor when cooling fan alarm occurs. (Alarm contact is ON at alarm occurrence).

After alarm occurrence, make sure to stop the SERVOMOTOR and fan motor within five minutes since SERVOMOTOR self-cooling protection is set to five minutes.

When cooling fan starts running, alarm detection signal turns ON for three seconds. Therefore, add a delay relay to the circuit for this time setting (three seconds).

### 4.6.5 Impact Resistance

When mounted horizontally and exposed to vertical shock impulses, the motor can withstand up to two impacts with impact acceleration of  $500\text{m/s}^2$  (50G) (Fig.4.11).

#### NOTE

A precision detector is mounted on the opposite-drive end of AC SERVO-MOTOR. Care should be taken to protect the shaft from impacts that could damage the detector.

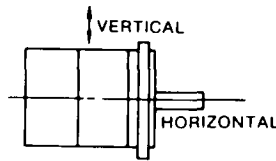

Fig. 4.11 Impact Resistance

### 4.6.6 Vibration Resistance

When mounted horizontally, the motor can withstand vibration (vertical, lateral, axial) of  $25\text{m/s}^2$  (2.5G) (Fig.4.12).

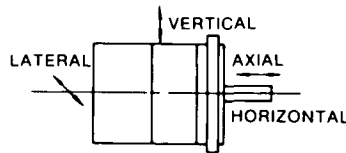

Fig. 4.12 Vibration Resistance

### 4.6.7 Vibration Class

Vibration of the motor running at rated speed is  $15\ \mu\text{m}$  or below (Fig.4.13).

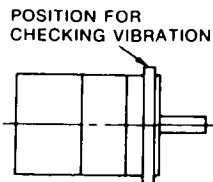
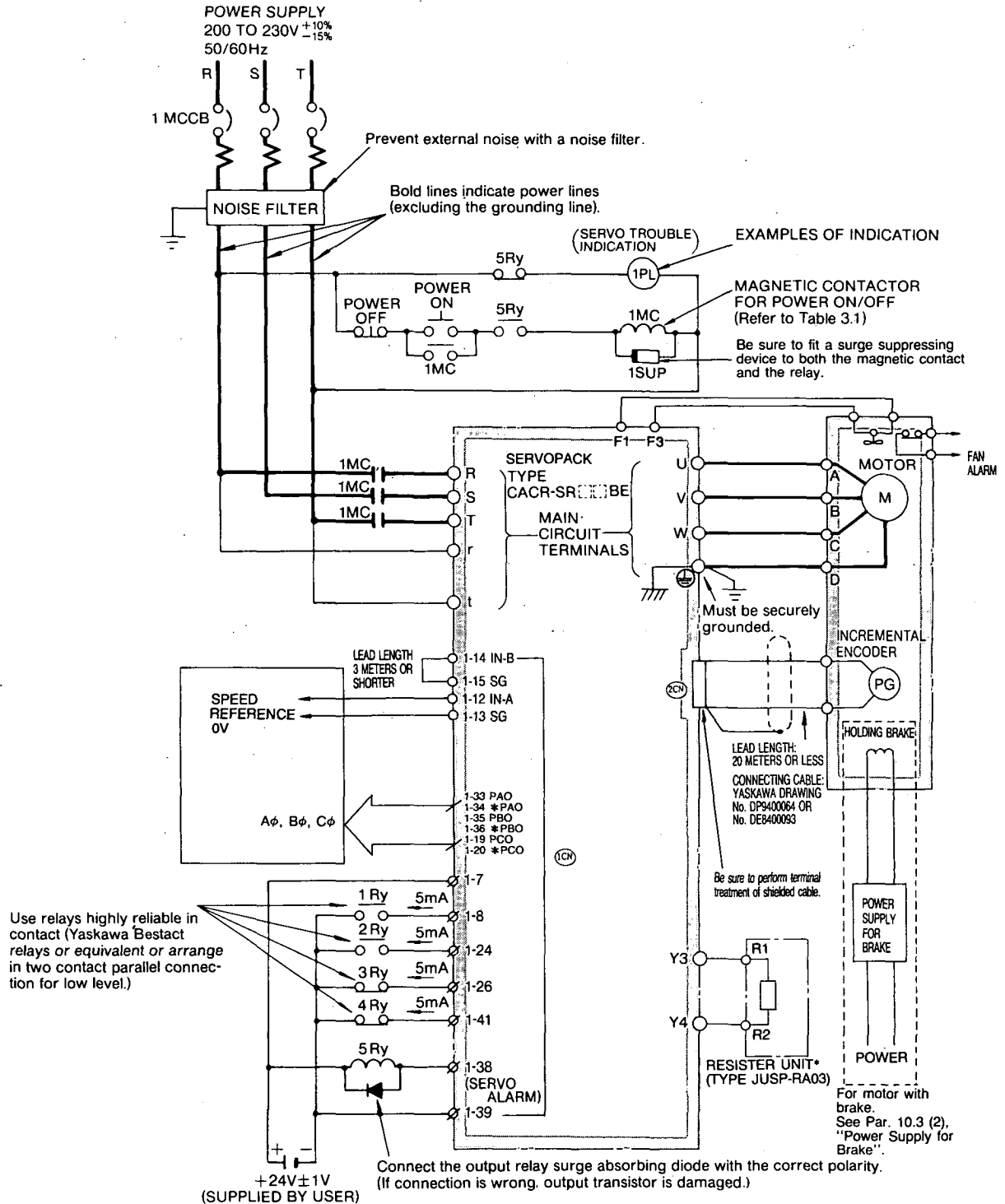

Fig. 4.13 Vibration Checking



# 5. CONFIGURATION

## 5.1 CONNECTION DIAGRAM



\*Added only when SERVOPACK type is SR60BE.

Fig. 5.1 Example of Connection Diagram of SERVOPACK with a SERVOMOTOR and Peripherals

## 5.2 MAIN CIRCUIT TERMINALS

Table 5.1 shows the specifications of main circuit terminals for SERVOPACK.

Table 5.1 Main Circuit Terminals for SERVOPACK

Terminal Symbol	Name	Description
(R) (S) (T)	Main-circuit AC input	Three-phase 200 to 230 VAC $\pm 10\%$ , 50/60 Hz.
(U) (V) (W)	Motor connection	Connects terminal (U) to motor terminal A, (V) to B and (W) to C.
(r) (t)	Control power input	Single-phase 200 to 230 VAC $\pm 10\%$ , 50/50 Hz.
(⊕)	Frame ground	Connects to motor terminal D. Must be securely grounded.
(Y3) (Y4)	Regenerative resistor	External connection not normally required. (Connection required for type SR60BE.)
(F1) (F3)	Fan connection	Connects only for types SR60BE.

## 5.3 APPLICABLE RECEPTACLES

### 5.3.1 Specifications of Connector Terminal (1CN) for Input/Output Signal

Table 5.2 Specifications of Applicable Receptacles for SERVOPACK I/O Signals

Connector Type* used in SERVOPACK	Applicable Receptacle Type			
	Manufacturer	Soldering Type	Caulking Type	Case
MR-50RMA4 (Right angle 50 P)	Honda Tsushin Co., Ltd.	MR-50F†	MRP-50F01	MR-50L†

\* The connectors for I/O signals used are type MR-50RMA made by Honda Tsushin Co.

† Attached to SERVOPACK prior to shipment.

### 5.3.2 Specifications of Connector Terminal (2CN) for Encoder

Table 5.3 Specifications of Applicable Receptacles for SERVOPACK Encoder

Connector Type* used in SERVOPACK	Applicable Receptacle Type				Specifications of Connecting Cable
	Manufacturer	Soldering Type	Caulking Type	Case	
MR-20RMA4 (Right angle 20 P)	Honda Tsushin Co., Ltd.	MR-20F†	MRP-20F01	MR-20L†	Yaskawa Drawing No. B9400064 or No. DE8400093

\* The connectors for encoder used are made by Honda Tsushin Co.

† Attached to SERVOPACK prior to shipment.

## 5.4 CONNECTOR TERMINAL (1CN) FOR I/O SIGNAL

### 5.4.1 Connector 1CN Layout and Connection of SERVOPACK

The terminal layout of the SERVOPACK I/O signal connectors (1CN) is shown in Table 5.4. The external connection and external signal processing are shown in Fig. 5.2 on page 31.

Table 5.4 Connector 1CN Layout of SERVOPACK

1	2	3	4	5	6	7	8	9	10	11	12	13	14	15	16	17	18	
0V	0V	0V	PHA	CLT +	CLT -	+24V IN	S-ON	TRQ -M	VTG -M	SG	IN-A	SG-A	IN-B	SG-B	+12V	SG	FG	
0V for PG Output Signal			Open Collector Output A φ	Current Limit Detection Output		Ext Power Input	Servo ON Power	Torque monitor			Speed Monitor		Speed Reference Input		Auxiliary Input		+12V Output	Frame Ground
			19	20	21	22	23	24	25	26	27	28	29	30	31	32		
			PCO	*PCO	PHC	TGON +	TGON -	P-CON	ALO1	N-OT	S-RDY -	S-RDY +	N-CL	SG-NCL	-12V	SG		
			Line Driver Output C φ		Open Collector Output C φ	TG ON Signal Output		P. Drive Input	Open Collector Output	Reverse Inhibit Input	Servo Ready Output		Reverse Current Limit Input		-12V Output			
33	34	35	36	37	38	39	40	41	42	43	44	45	46	47	48	49	50	
PAO	*PAO	PBO	*PBO	PHB	ALM +	ALM -	ALO2	P-OT	ALO3	ALM-RST	P-CL	SG-PCL	-12V	SG	+12V	SG	FG	
Line Driver Output A φ		Line Driver Output B φ		Open Collector Output B φ	Servo Alarm Output		Open Collector Output	Fwd. Inhibit Input	Open Collector Output	Alarm Reset Input	Fwd. Current Limit Input		-12V Output		+12V Output		Frame Ground	

Note: For input signal and method of application, refer to Table 5.5 and 5.6.

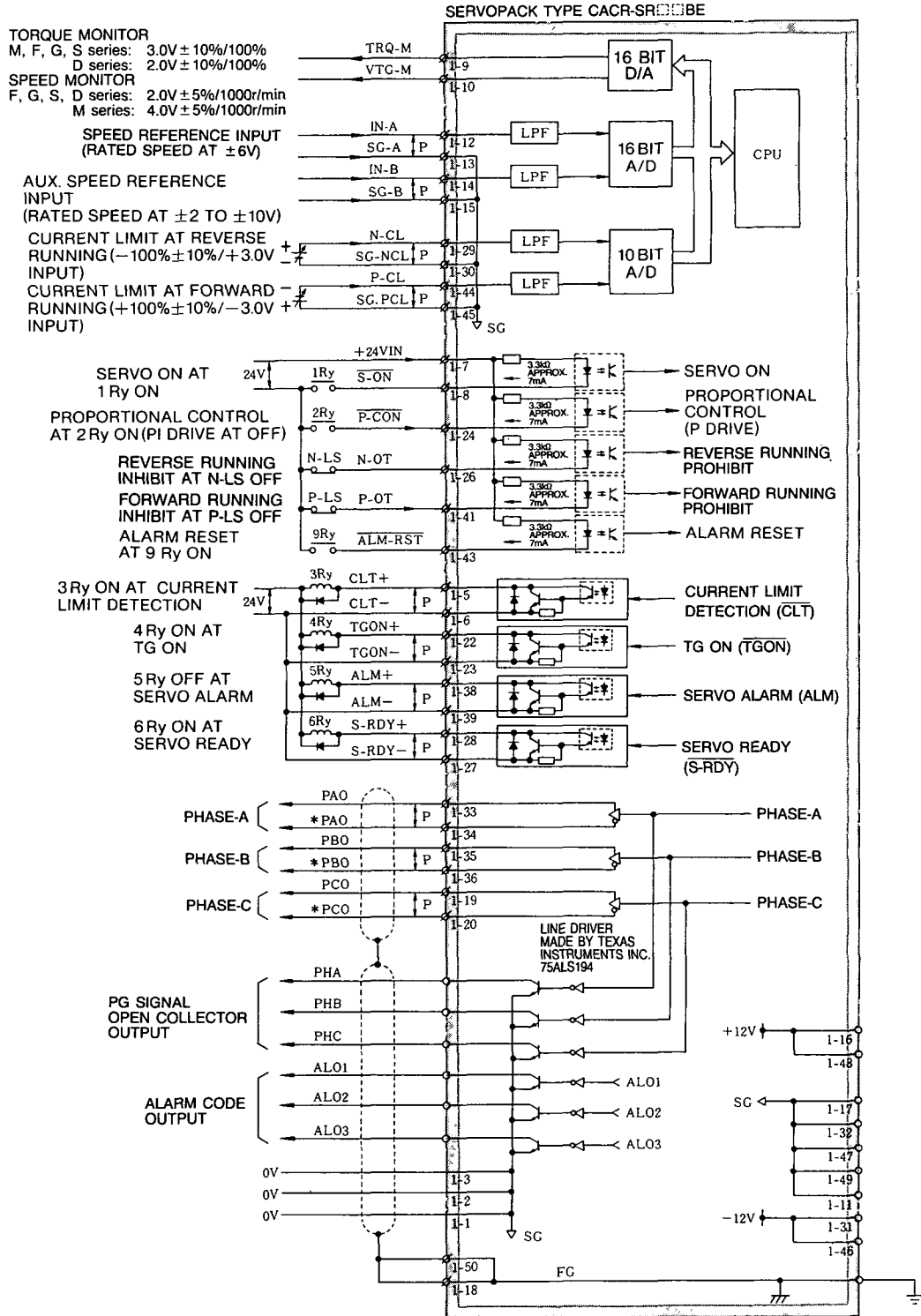

p : Twisted pair wires.

- Notes:
1. Each capacity of output circuits is 30VDC, 50mA or less.
  2. The user must provide the 24V power supply and battery.

Fig. 5.2 I/O Signals and Connector 1CN

## 5.4.2 Input Signals of Connector 1CN

Table 5.5 Input Signals

Signal Name	Connector 1CN No.	Function	Description
<u>S-ON</u>	1CN-8	Servo ON	<ul style="list-style-type: none"> <li>•Inputting this signal makes the SERVOPACK ready to receive speed reference input (+6 V).</li> <li>•Base block and dynamic brake are cleared.</li> </ul>
<u>P-CON</u>	1CN-24  (Three functions can be selected by parameter setting.)	Proportional drive reference	•Proportional control command to prevent drifting when the motor is left motionless without command input, while the main circuit is kept energized.
		Zero clamp drive reference	•Inputting this signal maintains the motor in servo lock (stop) status and prevents the motor from drifting.
		Changeover command for torque control/speed control	•In torque control II mode, this signal makes the SERVOPACK change torque control to speed control.
<u>N-OT</u>	1CN-26	Reverse running inhibit	•In the case of linear drive, etc., connect limit switch signal according to the run direction. This is a normally closed contact.
<u>P-OT</u>	1CN-41	Forward running inhibit	•Inputting this signal makes the SERVOPACK cancel the functions and become "normally N-OT" or "normally P-OT".
<u>+24 VIN</u>	1CN-7	24 V	•External power supply to 1CN-8, 24, 26, 41 and 43. Use an external 24 VDC (25 mA min.) power supply.
<u>IN-A</u>	1CN-12 (13)	Speed command input*	At $\pm 6.0$ V, $\pm$ rated speed is obtained.
<u>IN-B</u>	1CN-14 (15)	Aux. command input*	At $\pm 2.0$ V to $\pm 10.0$ V, $\pm$ rated speed is obtained.
		• When either of IN-A or IN-B is used, be sure to set the unused input "Zero specification".	
<u>N-CL</u>	1CN-29 (30)	Current limit at reverse running reference	+3.0 V $\pm$ 10%/100% torque +9V max.
<u>P-CL</u>	1CN-44 (45)	Current limit at forward running reference	-3.0 V $\pm$ 10%/100% torque -9V max.
<u>ALM-RST</u>	43	Alarm reset	Resets the servo alarm status.

\* Torque command input:  $\pm 3$ V/rated torque

### 5.4.3 Input Circuit

There are five kinds of input signals: Servo ON, proportional drive, overtravel prevention and alarm reset. Construct the input circuit using 24V power supply (Fig.5.3). Typical circuits are shown in Fig. 5.2.

#### NOTE

The user must provide the 24V power supply:  
24VDC  $\pm$  1V, 25mA or more (approx 5mA/circuit)

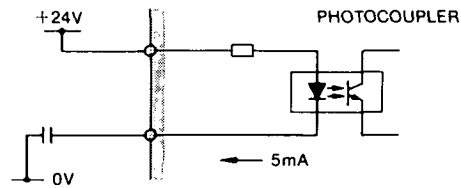

Fig. 5.3 Configuration of I/O Circuit

#### (1) Servo ON $\overline{[S-ON]}$

Turning this signal ON activates the power drive circuit of the SERVOPACK main circuit.

The motor cannot be started unless this signal is input (that is, in the servo-OFF status). When this signal is turned OFF while the motor is running, the motor is stopped by the dynamic brake. This signal is automatically input by setting bit 0 of user constant Cn-01. Don't start/stop the motor by servo ON/OFF.

#### (2) $\overline{P-CON}$

This input signal functions as any of the following three signals depending on bits A and B of user constant Cn-01.

##### (a) Proportional drive (P drive)

By setting user constant Cn-01 bit A to 0 and B to 0, P-CON input becomes proportional drive.

The drive may drift in open position loop. To avoid this, switch the speed amplifier from PI drive to P drive after the positioning and the loop gain in the control system drops and the drift decreases. With several percent of friction load, the motor stops completely.

##### (b) Zero clamp operation

By setting user constant Cn-01 bit A to 1 and B to 0, P-CON input becomes zero clamp operation input.

After the motor stops, it may be locked electrically. This function is applicable vertical loads. Continuous operation torque in servo-lock may not exceed 70% of the motor's rated torque.

##### (c) Torque/speed control changeover

Setting user constant Cn-01 bits A and B to 1 enters the torque control mode II.

In torque control mode II, this signal switches between torque and speed control.

(3) P-OT, N-OT (forward overtravel, reverse overtravel)

These input are used to stop the forward running of the motor (counterclockwise when viewed from the drive end of the motor) and reverse running. When the overtravel prevention input is not used, connect 1CN-(26) and -(41) to the 0 V of the external 24 V power supply, or invalidate this function by setting bit 2 and 3 of user constant Cn-01.

Operation to be performed when an overtravel occurs can be selected from the following four by setting bit 6, 7, or 8 of user constant Cn-01.

(a) Coasting to a stop (Cn-01, bit 6=1)

When overtravel occurs, the motor coasts to a stop.

(b) DB stop (Cn-01, bit 6=0)

When overtravel occurs, the motor is stopped by the dynamic brake. Whether the brake is released after the motor stops or not is decided by bit 7 of user constant Cn-01.

(c) Stop at the torque specified by user constant Cn-01, bit 8=1

When overtravel occurs, regardless of speed reference, the internal circuit forcibly changes speed reference to zero and immediately stops the motor. After the motor stops, it is released free. Stop torque is decided by Cn-06, emergency stop torque.

(d) Zero-clamp after stopping at the torque specified by user constant Cn-01, bit 8=1

After the motor stops as (c) above, it is held in zero-clamp mode.

(4) Alarm reset ( $\overline{\text{ALMRST}}$ )

This is an external reset signal for servo alarm. Remove the cause of the alarm before restarting operation. For safety, set a 0V speed reference (torque reference) when inputting the reset signal.

## 5.4.4 Use of Output Signals

Table 5.6 Output Signal

Signal Name	Connector 1CN No.	Function	Description
ALM	38 (39)	Servo alarm	<ul style="list-style-type: none"> <li>Turns OFF when fault is detected.</li> <li>For details, refer to Table 6. 1, "Fault Detection Function."</li> </ul>
$\overline{\text{TGON}}$ (BK)	22 (23)	Rotation detection	<ul style="list-style-type: none"> <li>Turns ON when motor speed exceeds speed set by user constant.</li> </ul>
		Brake interlock output	<ul style="list-style-type: none"> <li>Outputs timing signal of external brake signal.</li> </ul>
$\overline{\text{CLT}}$	5 (6)	Current limit detection	<ul style="list-style-type: none"> <li>N-CL or P-CL used: Turns ON when output torque reaches the lower level set by N-CL, P-CL or <math>\overline{\text{TLMTF}}</math> <math>\overline{\text{TLMTR}}</math>.</li> <li>N-CL or P-CL not used: Turns ON when output torque reaches the level set by <math>\overline{\text{TLMTF}}</math> <math>\overline{\text{TLMTR}}</math>.</li> </ul>
$\overline{\text{S-RDY}}$	28 (27)	Servo ready	<ul style="list-style-type: none"> <li>Turns ON when main power supply ON and servo alarm OFF.</li> </ul>
+ 12V 0V - 12V	16, 48 17, 32, 47, 49 31, 46	} $\pm 12\text{V}$ Output Power supply	<ul style="list-style-type: none"> <li><math>\pm 12\text{V}</math> <math>\pm 5\%</math> max output current: 30 mA</li> <li>Used with speed command or current input.</li> </ul>
TRQ-M	9		Torque monitor
VTG-M	10	Speed monitor	<ul style="list-style-type: none"> <li><math>\pm 2.0\text{V}/1000\text{r}/\text{min}</math> <math>\pm 5\%</math> (F, G, D, S series)</li> <li><math>\pm 4.0\text{V}/1000\text{r}/\text{min}</math> <math>\pm 5\%</math> (M series)</li> <li>Load: 1 mA max</li> </ul>
PAO *PAO PBO *PBO PCO *PCO	33 34 35 36 19 20	PG Signal Output-1 Phase A PG Signal Output-1 Phase $\overline{\text{A}}$ PG Signal Output-1 Phase B PG Signal Output-1 Phase $\overline{\text{B}}$ PG Signal Output-1 Phase C PG Signal Output-1 Phase $\overline{\text{C}}$	<ul style="list-style-type: none"> <li>Pulse after frequency division is output line driver (MC 3487*).</li> <li>To be received by line receiver (MC 3486*).</li> </ul>
PHA PHB PHC	4 (1) 37 (2) 21 (3)	PG Signal Output-2 Phase A PG Signal Output-2 Phase B PG Signal Output-2 Phase C	<ul style="list-style-type: none"> <li>Open collector output Pulse after frequency division.</li> <li>Max operating voltage: 30 VDC</li> <li>Max output current: 20 mA DC</li> </ul>
ALO1 ALO2 ALO3	25 (1) 40 (2) 42 (3)	Alarm Output Code (BCD code)	<ul style="list-style-type: none"> <li>Open collector output</li> <li>Max Operating voltage: 30V DC</li> <li>Max output current: 20 mA DC</li> </ul>

\* Made by Texas Instruments Inc.



## 5.4.5 Output Circuit

### (1) Sequence signal output circuit

There are four non-contact output signals, employing transistors: Current limit detection, TG ON, Servo alarm, Servo ready, and three alarm codes with open collector output.

Voltage and current specifications are:

$$\text{Applied Voltage (V max)} \leq 30\text{V}$$

$$\text{Conduction Current (I}_p\text{)} \leq 100 \text{ mA}$$

### NOTE

The output circuit requires a separate power supply of 20mA or below for open collector output. It is recommended to use the same 24V power supply used for the input circuit (**Fig. 5.4**).

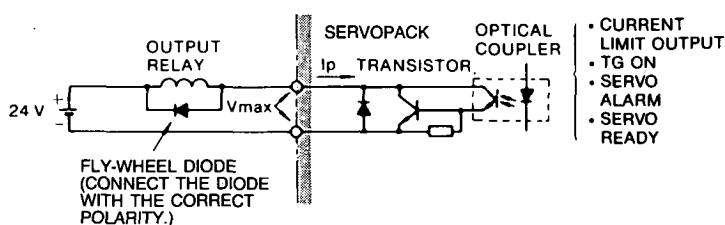

Fig. 5.4 Output Circuit

### (2) Optical encoder (PG) output circuit [PAO, \*PAO, PBO, \*PBO, PCO, \*PCO]

Phases A, B, and C (original point) signals for the optical encoder, PG are output.

Use these signals as positioning signals. The output signal specifications are as follows:

#### (a) Signal form

- Two-phase pulse with 90° pulse difference (phases A and B)
- Original point pulse (phase C)

#### (b) Output circuit and receiver circuit

Two types of output circuits are provided: line driver output and open collector output. Fig. 5.5 shows an example of line driver output.

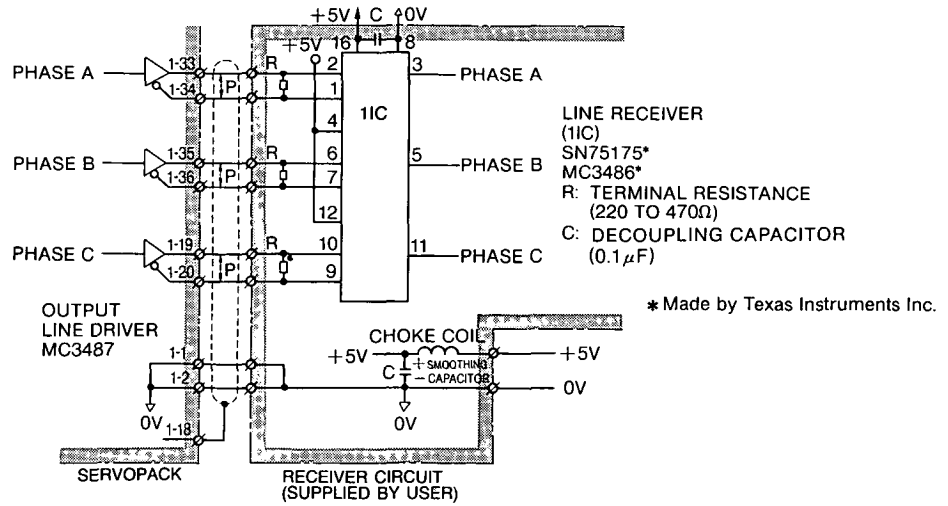

Fig. 5.5 Output Circuit and Receiver Circuit

(c) Output phase (frequency dividing ratio: 1/1)

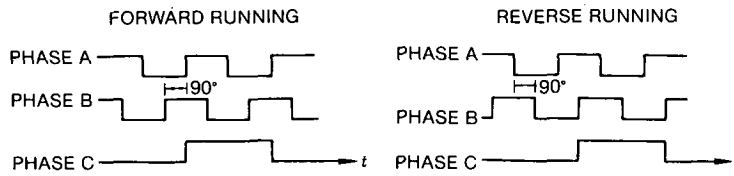

Fig. 5.6 Output Phase

For details of frequency division, refer to Par. 7 (8), "USER CONSTANT".

## 5.5 CONNECTOR TERMINAL (2CN) FOR OPTICAL ENCODER CONNECTION

### 5.5.1 Connector Layout

Table 5.7 Connector 2CN Layout of SERVOPACK

1	2	3	4	5	6	7
PG0V	PG0V	PG0V	PG5V	PG5V	PG5V	DIR
8	9	10	11	12	13	
14	15	16	17	18	19	20
PC	*PC	PA	*PA	PB	*PB	FG

### 5.5.2 Cable Specifications

The cables listed in Table 5.8 are available on request. If required, purchase in units of standard length.

Table 5.8 Cable Specifications

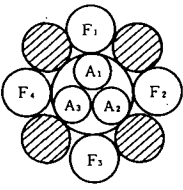
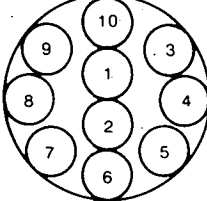
Connection	Soldered Type	Caulking Type																																		
YASKAWA Drawing No.	B9400064	DE 8400093																																		
Manufacturer	Fujikura Cable Co.																																			
General Specifications	Double, KQVV-SW AWG 22 × 3 C AWG 26 × 4 P	KQVV-SB AWG 26 × 10 P																																		
Finishing Dimensions	φ7.5mm	φ10.0mm																																		
(Recommended) Receptacle Type	For Soldered Type	For Caulking Type																																		
																																				
Internal Composition and Lead Color	<table border="1"> <tr><td>A<sub>1</sub></td><td>Red</td></tr> <tr><td>A<sub>2</sub></td><td>Black</td></tr> <tr><td>A<sub>3</sub></td><td>Green yellow</td></tr> <tr><td>F<sub>1</sub></td><td>Blue-White/blue</td></tr> <tr><td>F<sub>2</sub></td><td>Yellow-White/yellow</td></tr> <tr><td>F<sub>3</sub></td><td>Light green-White/light green</td></tr> <tr><td>F<sub>4</sub></td><td>orange-White/orange</td></tr> </table>	A <sub>1</sub>	Red	A <sub>2</sub>	Black	A <sub>3</sub>	Green yellow	F <sub>1</sub>	Blue-White/blue	F <sub>2</sub>	Yellow-White/yellow	F <sub>3</sub>	Light green-White/light green	F <sub>4</sub>	orange-White/orange	<table border="1"> <tr><td>1</td><td>Blue-White</td></tr> <tr><td>2</td><td>Yellow-White</td></tr> <tr><td>3</td><td>Green-White</td></tr> <tr><td>4</td><td>Red-White</td></tr> <tr><td>5</td><td>Purple-White</td></tr> <tr><td>6</td><td>Blue-Brown</td></tr> <tr><td>7</td><td>Yellow-Brown</td></tr> <tr><td>8</td><td>Green-Brown</td></tr> <tr><td>9</td><td>Red-Brown</td></tr> <tr><td>10</td><td>Purple-Brown</td></tr> </table>	1	Blue-White	2	Yellow-White	3	Green-White	4	Red-White	5	Purple-White	6	Blue-Brown	7	Yellow-Brown	8	Green-Brown	9	Red-Brown	10	Purple-Brown
A <sub>1</sub>	Red																																			
A <sub>2</sub>	Black																																			
A <sub>3</sub>	Green yellow																																			
F <sub>1</sub>	Blue-White/blue																																			
F <sub>2</sub>	Yellow-White/yellow																																			
F <sub>3</sub>	Light green-White/light green																																			
F <sub>4</sub>	orange-White/orange																																			
1	Blue-White																																			
2	Yellow-White																																			
3	Green-White																																			
4	Red-White																																			
5	Purple-White																																			
6	Blue-Brown																																			
7	Yellow-Brown																																			
8	Green-Brown																																			
9	Red-Brown																																			
10	Purple-Brown																																			
(Standard Application: B9400064)	Twisted pair wires																																			
YASKAWA Standard Specifications	Standard length: 5m, 10m, 20m Terminal ends are not provided (without connectors).																																			

#### NOTE

1. When applicable cables listed in Table 5.8 are used, allowable wiring distance between SERVOPACK and motor is a maximum of 20 meters.
2. The cable applied for 50 m wiring distance is available on order (Yaskawa drawing No. DP8409179). If wiring distance is 20m or more, contact your YASKAWA representative. Cables must be assembled by authorized vendor with appropriate tooling.

### 5.5.3 Method of Connection

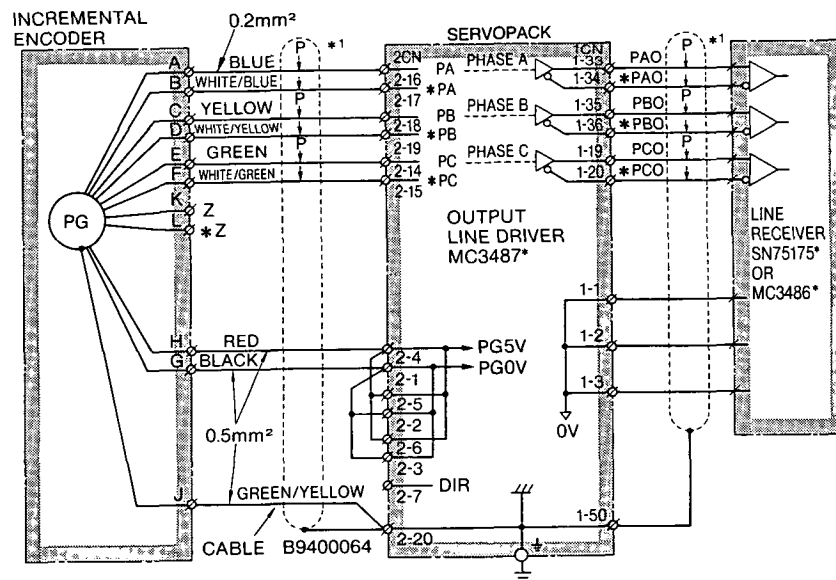

\*1 : Twisted pair wires

\*Made by Texas Instruments Inc.

Note: Connector specifications of incremental encoders are as follows.  
 connector—Type MS3102A20-29P (Receptacle)  
 Accessory (not attached)—Type MS3108B20-29S (Angle plug)  
 Type MS3057-12A (Cable clamp)

Fig. 5.7 Soldered Type Connector 2CN Connection and 1CN Output Processing  
 (When using Connection Cable B9400064)

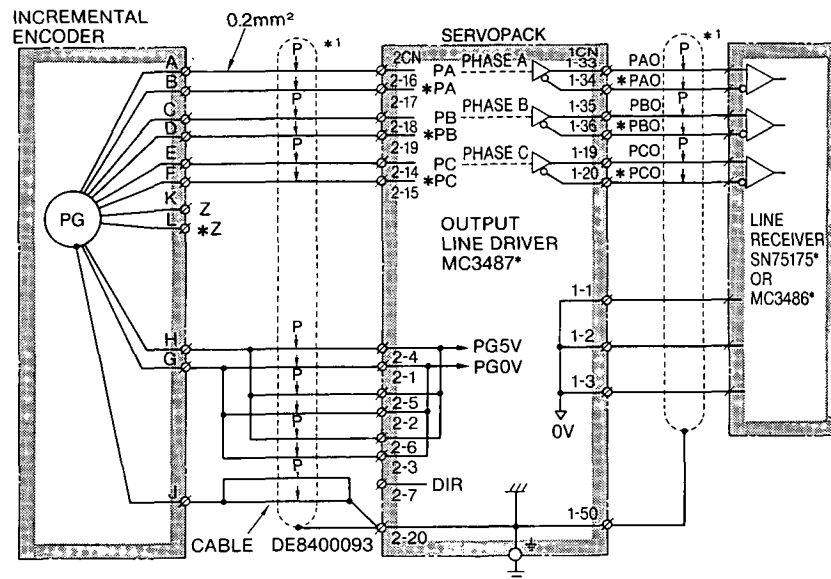

\*1 : Twisted pair wires

\*Made by Texas Instruments Inc.

Note: Connector specifications of incremental encoder are as follows.  
 Connector—Type MS3102A20-29P (Receptacle)  
 Accessory (not attached)—Type MS3108B20-29S (Angle plug)  
 Type MS3057-12A (Cable clamp)

Fig. 5.8 Caulking Type Connector 2CN Connection and 1CN Output Processing  
 (when using Connection Cable DE8400093)

# 5.6 INTERNAL CONNECTION DIAGRAM

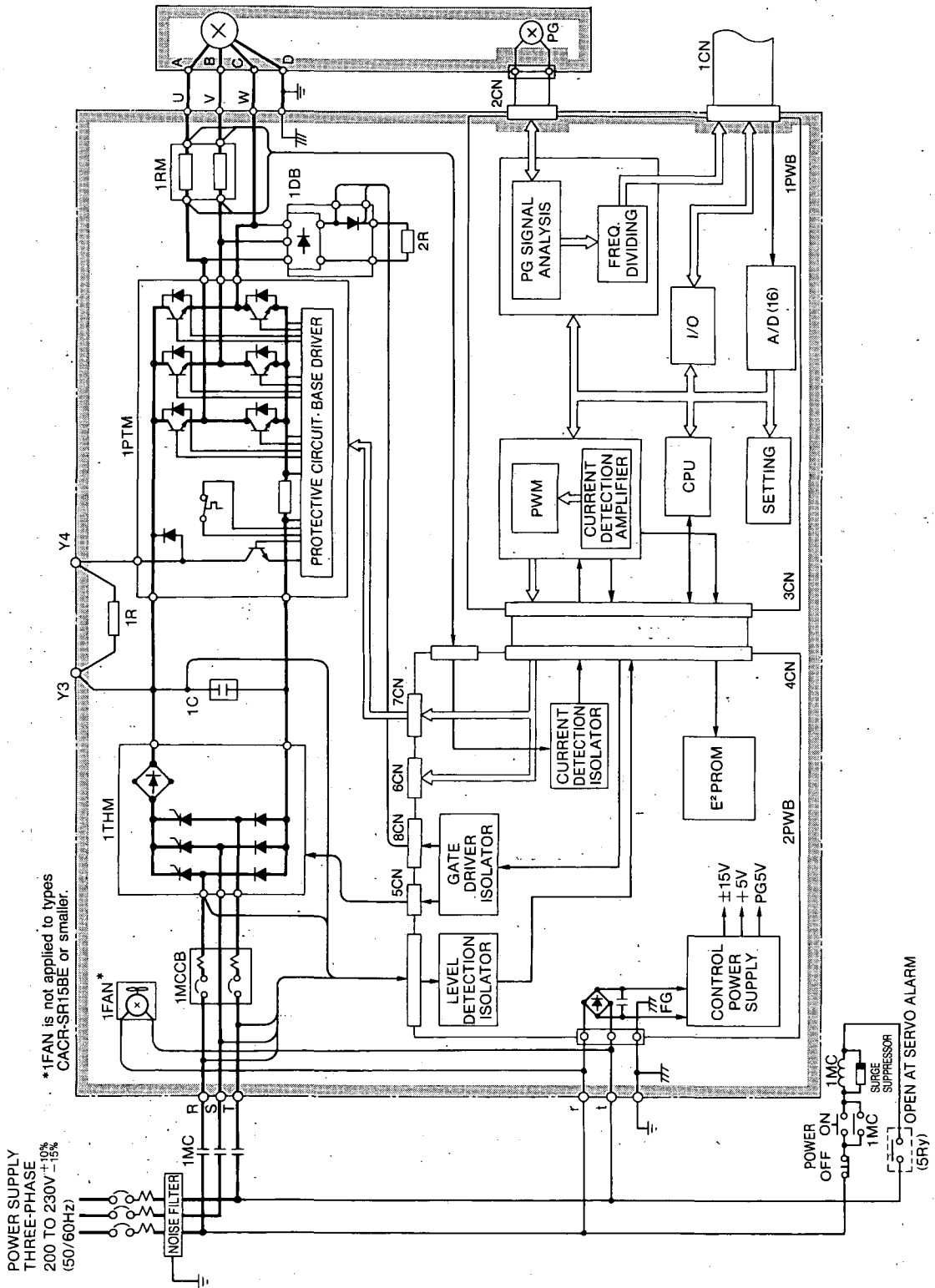

Fig. 5.9 Internal Block Diagram of SERVOPACK



## 6. OPERATION

### 6.1 POWER ON AND OFF

Arrange the sequence so that the power is simultaneously supplied to the main circuit (R, S, T) and the control circuit (r, t), or supplied to the control circuit first, then to the main circuit (Figs. 6.1 and 6.2).

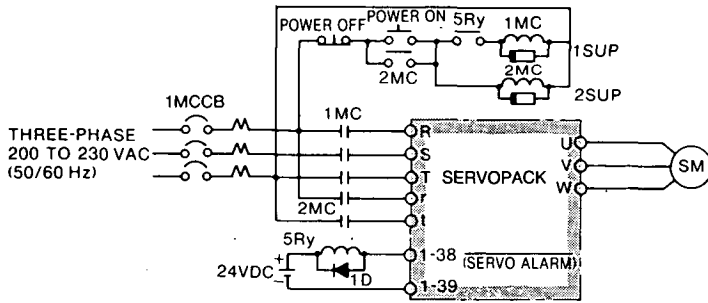
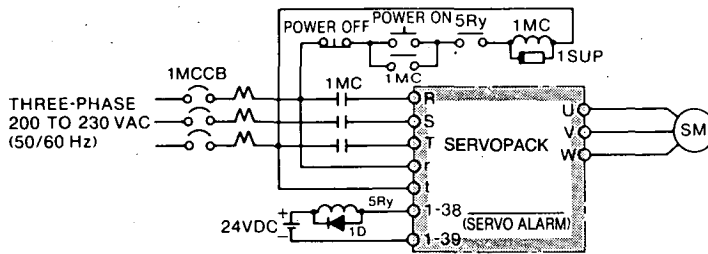

Fig. 6.1 Connection Example for Simultaneous Control Power ON/OFF



1SUP, 2SUP: Surge suppressor  
1D: Flywheel diode (to prevent 5Ry spike)

Fig. 6.2 Connection Example for Main-circuit Power ON/OFF

Arrange the sequence so that the power is simultaneously cut (including momentary power failure) (Fig. 6.1), or the power to the main circuit is cut first, then the control circuit (Fig. 6.2). The order is the reverse of the power ON sequence.

### Precautions for Connections in Figs. 6.1 and 6.2

- Make sequence to assure that the main circuit power will be cut OFF by a servo alarm signal. (Alarm is written on E<sup>2</sup>PROM, so when the main and control power are turned OFF simultaneously, the alarm contents can be checked if the control power is turned ON again.)
- When power is supplied in the power ON/OFF sequence shown in Fig. 6.1, the normal signal is set (5Ry is turned ON) in the control circuit after a maximum delay of 3 seconds.

#### NOTE

When the power is turned ON, a servo alarm signal continues for approximately 3 seconds to initialize the SERVOPACK.

- Since SERVOPACK is of a capacitor input type, large in-rush current flows when the main circuit power is turned ON (recharging time : 0.5 to 1.0 s.) If the power is turned ON and OFF frequently, the in-rush current limiter may be degraded and a malfunction may occur. When the motor starts, turn ON the speed reference and turn it OFF when the motor stops. Do not turn the power ON or OFF.
- Before power ON or OFF, turn OFF the "Servo ON" switch to avoid transient troubles.

## 6.2 SPEED REFERENCE

### 6.2.1 Speed Reference Circuit

From the SERVOPACK built-in control power (1CN-⑯, ⑳ : +12V, 1CN-㉑, ㉒, ㉓, ㉔ : 0V, 1CN-㉕, ㉖ : -12V) or the external power, the speed reference voltage is given to 1CN-㉗ and ㉘ or to 1CN-㉙ and ㉚. When the SERVOPACK built-in control power is used, the motor speed fluctuates in the range of  $\pm 2\%$  of the speed set value.

The method for giving speed reference voltage is described below.

(1) For accurate (inching) speed setting

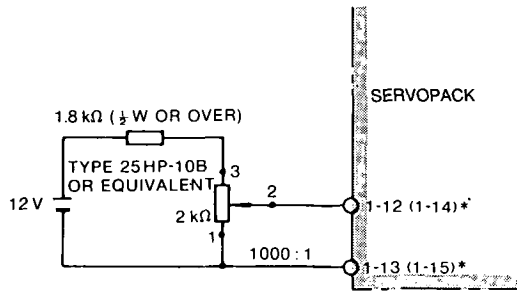

25HP-10B type: Multiple-rotation type, wire wound variable resistor (with dial MD10-30B4) made by Sakae Tsushin Inc.

(a) When Multiple-rotation Type, Wire-Wound Variable Resistor is used

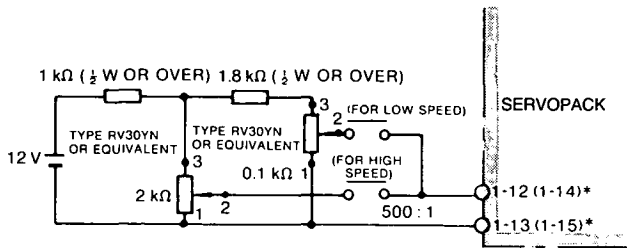

RV30YN type: Carbon-film variable resistor made by Tokyo Cosmos Electric.

Low- and high-speed relays: Reed relay

Note: When a carbon resistor is used, great residual resistance remains, so the speed control range becomes approximately 500:1.

(b) When Carbon Variable Resistor is used

\* Parentheses are for auxiliary input.

Fig. 6.3 Method for Giving Speed Reference Voltage [for Accurate (inching) Speed Setting]

(2) For relatively rough speed setting

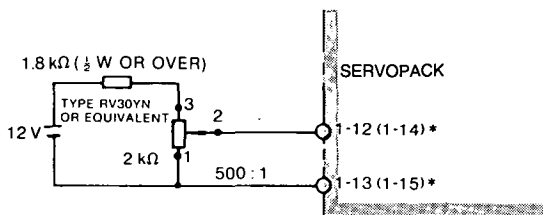

\* Parentheses are for auxiliary input.

Note: When a carbon resistor is used, great residual resistance remains, so the speed control range becomes about 500:1.

Fig. 6.4 Method for Giving Speed Reference Voltage (for relatively Rough Speed Setting as Compared with Fig. 6.3)



### 6.2.2 Stop Reference Circuit

When giving a stop reference, do not open the speed reference circuit (1CN-⑫ 1CN-⑭), but set to 0V.

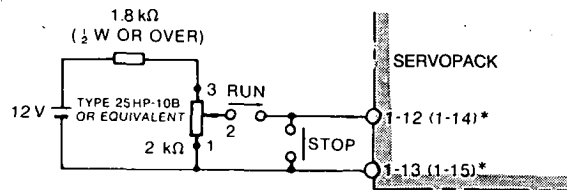

(a) When Multiple-rotation Type, Wire Wound Variable Resistor is used

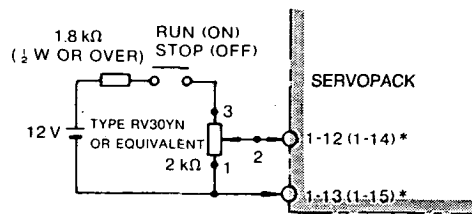

(b) When Carbon Variable Resistor is used

\* Parentheses are for auxiliary input.

Fig. 6.5 Method for Giving Stop Reference

### 6.2.3 Handling of Speed Reference Input Terminal

The unused terminals, out of the speed reference terminals 1CN-⑫, ⑬ or the auxiliary input terminal, 1CN-⑭, ⑮ must be short-circuited or select "Zero-speed Reference" by setting bits 4 or 5 of user constant Cn-01. Refer to Table 7.1.

### 6.2.4 Auxiliary Input Circuit ( $\pm 2$ to $\pm 10V$ )

Auxiliary input circuit is used for application at rated reference voltage other than  $\pm 6V$ .

- Adjustment procedures

For parameter setting of auxiliary input reference, input motor speed per 1V (r/min/V) to user constant INBGN.

When combined with YASKAWA POSITIONPACK in positioning system drive, auxiliary input terminals are normally used as speed reference input. In this case, positioning loop gain is adjusted by the user constant INBGN.

### 6.2.5 Speed Control with Zero Clamp

Speed control with zero clamp mode can be selected by setting user constant Cn-01 (bits A and B). In this mode, when the motor rotating speed goes below the user constant Cn-0F **ZCLVL** setting, speed reference is ignored and the motor speed is reduced to zero.

- The zero clamp operation starts when the P-CON signal is turned ON.
- In zero clamp speed control mode, P/PI control changeover cannot be switched unlike usual speed control mode since the  $\overline{\text{P-CON}}$  signal is used for turning the zero clamp function ON/OFF signal.

### 6.2.6 Soft Start Function

Motor accel/decel time can be set up.

<Setup Procedure>

Set the time (ms) required for the motor to reach the maximum rotating speed to user constant Cn-0F **SFSACC** .

### 6.2.7 Jog Function

Even if no speed reference is entered during a test run, the motor can be operated by a circuit board mounted switch. Jog speed (r/min) can be varied by adjusting the user constant Cn-10 **JOGSPD** .

## 6.3 TORQUE CONTROL

In the torque control mode, speed loop is disconnected and the motor is driven by torque reference. This mode provides two submodes: torque control I and torque control II. Submode changeover can be switched by changing user constant Cn-01 (bits A and B).

### 6.3.1 Torque Control I

Torque reference voltage is applied between input terminals 1CN 12 and 13 from the SERVOPACK incorporated control power supply (1CN-16, 48: +12 V; 1CN-17, 32, 47, 49: 0 V; 1CN-31, 46: -12 V) or external power supply.

3V/rated torque are preset at the factory prior to shipment. They can be changed by user constant Cn-13 **TCRFGN** .

Speed limit set by Cn-14 **TCRLMT** is effective only in torque control mode I.

The method for giving torque reference voltage is described below.

(1) For accurate (inching) torque setting

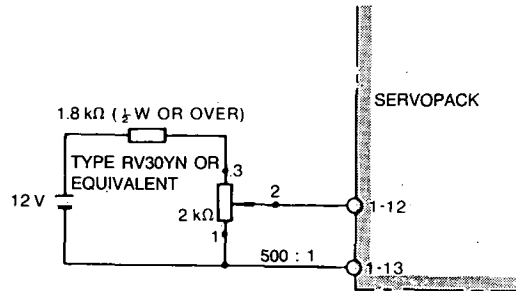

25HP-10B type: Multiple-rotation type, wire-wound variable resistor (with dial MD10-30B4) made by Sakae Tsushin Inc.

(a) When Multiple-rotation Type, Wire-Wound Variable Resistor is used

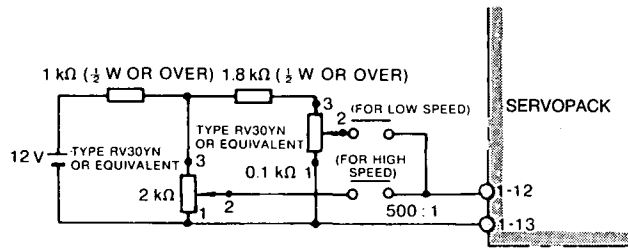

RV30YN type: Carbon-film variable resistor made by Tokyo Cosmos Electric.

Low- and high-speed relays: Reed relays

Note: When a carbon resistor is used, great residual resistance remains, so the torque control range becomes approximately 500:1.

(b) When Carbon Variable Resistor is used

Fig. 6.6 Method for Giving Torque Reference Voltage (for Accurate Torque Setting)

(2) For relatively rough torque setting

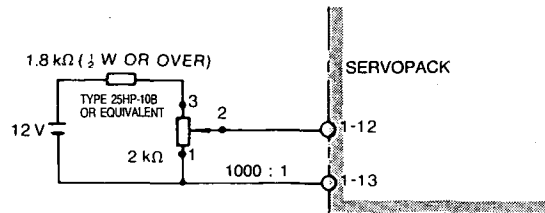

Note: When a carbon resistor is used, great residual resistance remains, so the torque control range becomes about 500:1.

Fig. 6.7 Method for Giving Torque Reference Voltage (for relatively Rough Torque Setting as Compared with Fig. 6.6)

### 6.3.2 Torque Control II (Speed-Limited Torque Control + Speed Control)

- In torque control II, torque control is performed along with the motor speed control using the motor speed limit function. Further, mode switching from torque control to speed control can be accomplished by turning ON the  $\overline{P-CON}$  signal.
- In torque control II, P/PI control changeover cannot be switched unlike usual speed control mode since the  $\overline{P-CON}$  signal is used for turning the torque/speed control mode changeover signal.
- Torque reference voltage is applied between input terminals 1CN 14 and 15 from the SERVOPACK incorporated control power supply (1CN-16, 48: +12 V; 1CN-17, 32, 47, 49: 0 V; 1CN-31, 46: -12 V) or external power supply. The speed limit voltage (a positive voltage sets both speed limits) is applied between input terminals 1CN 12 and 13. The I/O relationship is fixed at 3 V/rated torque (see note below).

Note: If a rating other than 3 V is desired, contact your YASKAWA representative.

Torque reference voltage and speed limit voltage application procedure examples are given below.

- For accurate (inching) torque or speed limit setting  
SERVOPACK input terminal numbers shown in Figs. 6.8 and 6.9 are for torque reference voltage input. Parenthesized terminal numbers are for speed limit voltage input.

(1) For accurate (inching) torque setting or speed limiting

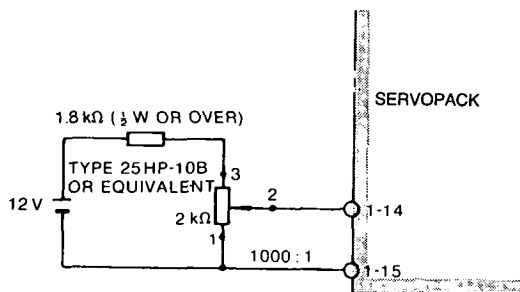

25HP-10B type: Multiple-rotation type, wire-wound variable resistor (with dial MD10-30B4) made by Sakae Tsushin Inc.

(a) When Multiple-rotation Type, Wire-Wound Variable Resistor is used

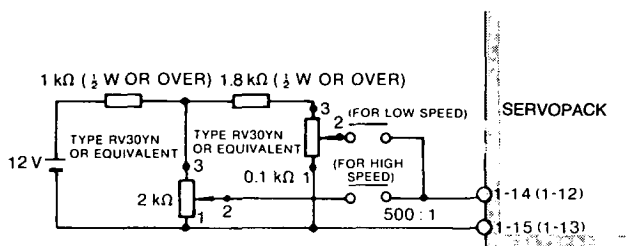

RV30YN type: Carbon-film variable resistor made by Tokyo Cosmos Electric.

Low- and high-speed relays: Reed relays

Note: When a carbon resistor is used, great residual resistance remains, so the torque control or speed limiting control range becomes approximately 500:1.

(b) When Carbon Variable Resistor is used

Fig. 6.8 Method for Giving Torque Reference or Speed Limiting Reference Voltage (for Accurate Speed Setting)

(2) For relatively rough torque setting or speed limiting setting

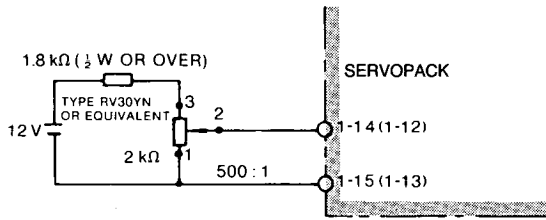

Note: When a carbon resistor is used, great residual resistance remains, so the torque control or speed limiting control range becomes about 500:1.

Fig. 6.9 Method for Giving Speed Reference Voltage (for relatively Rough as Compared with Fig. 6.8)

## 6.4 EXTERNAL CURRENT LIMIT REFERENCE CIRCUIT [P-CL, N-CL]

Current can be limited from the outside as well as within SERVOPACK. The external current limit is used for the following cases:

- To protect the motor from overload current when an abnormal load lock occurs in the load.
- To change the current limit value according to the external sequence.

The current can be limited by multi-stage setting by the use of relays (Fig. 6.10). The same effect can be obtained by giving voltage signals making analog change.

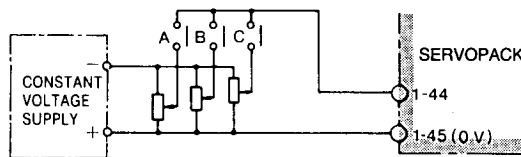

Relay: Low-level relay type G2A-432A made by Omron Corporation.

Fig. 6.10 Multi-stage Switching of Current Value at Forward Side

### 6.4.1 Method of Giving External Current Limit Reference

Forward current and reverse current can be controlled independently. The forward current can be controlled by giving a reverse voltage (0 to  $-9.0$  V) between SERVOPACK terminals 1CN- (44) and (45); the reverse current can be controlled by a forward voltage (0 to  $+9.0$  V) between terminals 1CN- (29) and (30).

Current limit reference voltage is  $3.0$  V/rated current depending on the applicable SERVOMOTOR. The power supply must use an internal resistance less than  $2k\Omega$ . The input resistance at SERVOPACK side must be greater than  $5k\Omega$ . When external current is not restricted, contacts between terminals 1CN- (44) and (45) and between 1CN- (29) and (30) are opened.

### 6.4.2 Set Voltage and Current Limit Values

The relationship between set voltages of 0 to  $\pm 9.0$  V and current limit values are shown in Fig. 6.11.

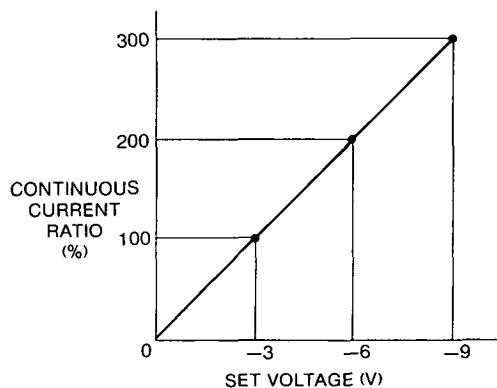

(a) Current Limit at Forward Side

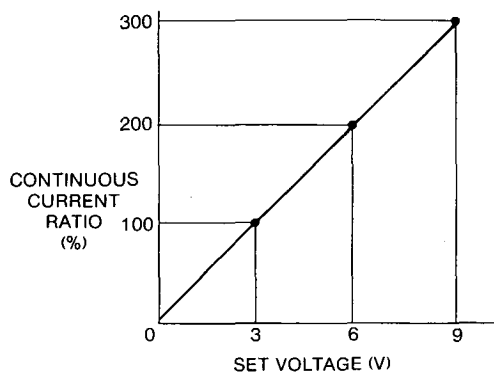

Note: If setting value exceeds max output current value of SERVOPACK, max output current value becomes saturation value.

(b) Current Limit at Reverse Side

Fig. 6.11 Set Voltage and Current Limit Values

### 6.4.3 Current Limit when Motor is Locked

When locking a motor by applying a current limit, determine a current limit value less than 70% of the rated current of the motor. If the load condition requires a current limit exceeding the rated motor current, refer to Fig 4.1, "Allowable Overload Curve of SERVOPACK" (in Par. 4.1) and make sure to unlock the motor before reaching the trip level.

Note that when the speed reference voltage is less than tens or so millivolts (affected by setting of user constant `INBGN` `LOOPHZ`), the motor lock current sometimes pulsates. If this is not desirable, the current pulsation can be removed by increasing the speed reference voltage.

## 6.5 PROTECTIVE FUNCTIONS

SERVOPACK provides functions to protect the drive and motor from malfunctions.

### (1) Alarm detecting function

SERVOPACK stops the power to motor by alarm detecting function at operation or circuit fault. The detected alarm contents are displayed by LED indication. For the LED indications, refer to Table 14.2.

### (2) Emergency stop function

SERVOPACK provides an emergency stop function upon malfunction. Method of emergency stop is selected by user constant Cn-01.

- ① The following three modes can be selected for stop methods.
  - DB stop (Dynamic brake stop)
  - Coasts to a stop
  - Zero-speed stop
- ② Any of the following four modes can be selected after emergency stop.
  - DB stop status
  - DB stop clear
  - BB (base block) status
  - Zero clamp status (For details, see Par. 7 "USER CONSTANTS".)

Standard setting is the stop by dynamic brake. This brake operates when:

- Alarm (fault) detection occurs.
- Servo ON input is opened.
- Power supply is turned OFF.
- Overtravel (P-OT, N-OT) occurs.

Perform the motor stop by dynamic brake only at emergency. If the emergency stop by dynamic brake is performed frequently, the in-rush current limit resistor may be degraded and a malfunction may occur. When stopping the motor during normal operation, turn OFF the speed reference and do not use an emergency stop function.

### (3) Servo alarm output (ALM+, ALM-)

If any of the alarm detections in (2) are activated, the power drive circuit in the SERVOPACK is turned OFF and its detection contents are displayed on a 7-segment LED and servo alarm signal is output externally.

#### (4) Protective circuit operation

An alarm signal indicates there is trouble. Check the cause, take proper corrective action, and restart the operation.

Procedure for troubleshooting:

Before checking the cause, turn OFF the power to the main circuit to avoid danger.

Arrange the sequence so that this alarm signal cut the power to main circuit ((R), (S), (T)) as shown in Figs. 6.1 and 6.2. For traceback, refer to Par. 8.6, "FAULT TRACEBACK MODE."

### CAUTION

When an alarm signal cuts OFF only the main circuit, check the cause and correct the trouble to resume the operation to avoid secondary malfunctions. When resuming the operation, make sure to set the speed reference (torque reference) to 0V before supplying power to the main circuit to avoid danger.

#### (5) Resetting servo alarm

To reset a servo alarm, use external signal input ( $\overline{\text{ALM-RST}}$ , 1CN-43) or depress SW1, SW2 and SW3 simultaneously in the monitor panel status display mode. (Refer to Par. 8.3.)

As for alarm A.10 (overcurrent detection), reset cannot be performed safely. Turn OFF the power and check the wiring before turning ON the power again.

As for alarms A.71 and A.72 (overload detection), turn ON the power again after one minute of alarm resetting since motor and SERVOPACK may be overheated.

#### (6) Holding brake interlock signal

A brake signal can be output for interlocking motor circuit power ON/OFF status and motor speed by user constant setting.

[Setup procedure]

When the user constant (memory switch) is set to provide the braking function, the brake signal (BK) is output from the 1NC-22,23 (TGON). Delay time  $t_B$  [ $\times 10\text{ms}$ ] from start of braking to motor power OFF can be adjusted by setting a value for user constant Cn-12 BRKTIM.



Table 6.1 Timing with Servo ON Signal and Main Circuit Power Supply

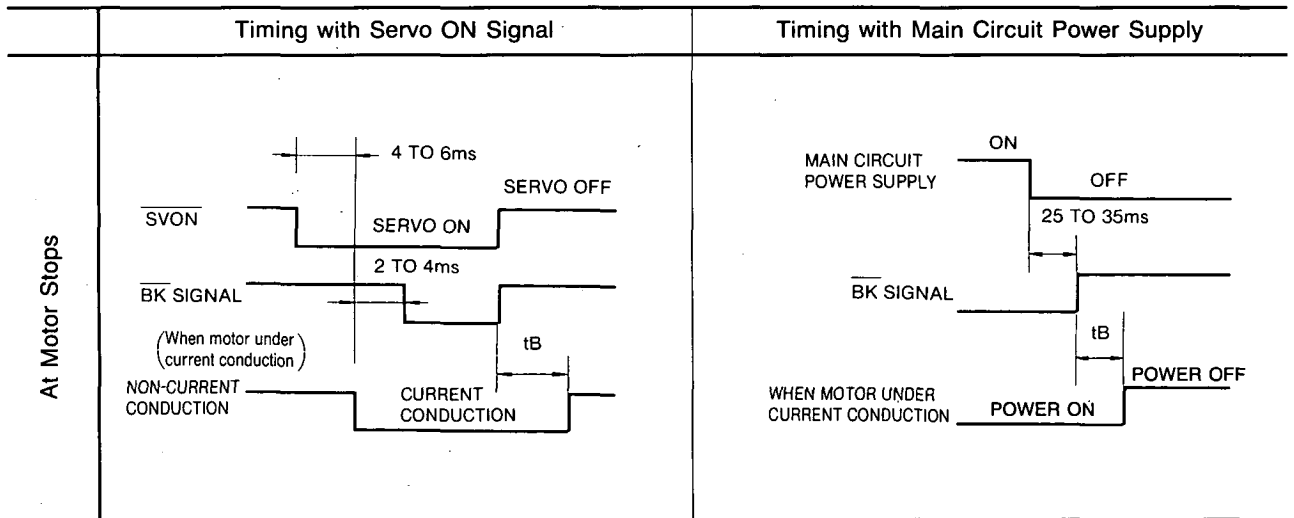

tB : Braking time (setting 10 to 500 ms at BRKTIM : Cn-12)

Timing at Servo OFF, Main Circuit Power Supply OFF or Alarm Occurrence

During Motor Running

- Servo OFF
- Alarm Occurrence
- Power OFF
- Motor Power ON/OFF
- BK Signal
- Motor Speed

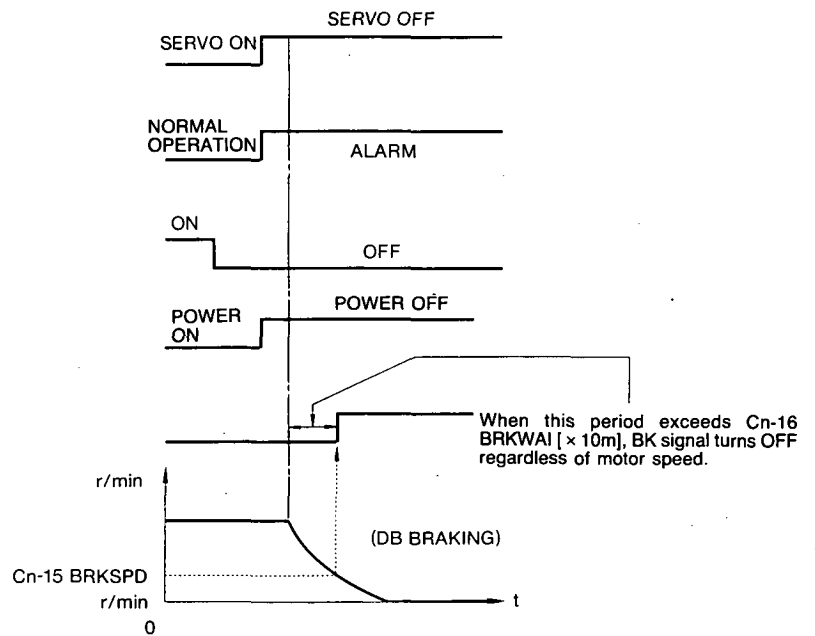

## 6.6 PRECAUTIONS FOR APPLICATION

### 6.6.1 Overhanging Loads

The motor is rotated by the load; it is impossible to apply brake (regenerative brake) against this rotation and achieve continuous running.

Example: Driving a motor to lower objects (with no counterweight)

Since SERVOPACK has short time regenerative brake capability (corresponding to the motor stopping time), for application to an overhanging load, contact your YASKAWA representative.

### 6.6.2 Load Inertia ( $J_L$ )

The allowable load inertia  $J_L$  converted to the motor shaft must be within five times the inertia of the applicable AC SERVOMOTOR. If the allowable inertia is exceeded, an overvoltage alarm may be occurred during deceleration. If this occurs, take the following actions:

- Reduce the current limit.
- Slow down the deceleration curve.
- Decrease the maximum speed.

For details, contact your YASKAWA representative.

### 6.6.3 High Voltage Line

If the supply voltage is 400/440 V, the voltage must be dropped to 200 V using a power transformer. **Table 6.3** shows the transformer selection. Connection should be made so that the power is supplied and cut through the primary side of the transformer.

## 6.7 PRECAUTIONS OF OPERATION

### 6.7.1 Noise Control

SERVOPACK uses a power transistor in the main circuit. When these transistors are switched, the effect of  $\frac{di}{dt}$  or  $\frac{dv}{dt}$  (switching noise) may sometimes occur depending on the wiring or grounding method.

SERVOPACK incorporates a CPU. This requires wiring and provision to prevent noise interference. To reduce switching noise as much as possible, the recommended method of wiring and grounding is shown in Fig. 6.12.

#### (1) Grounding method

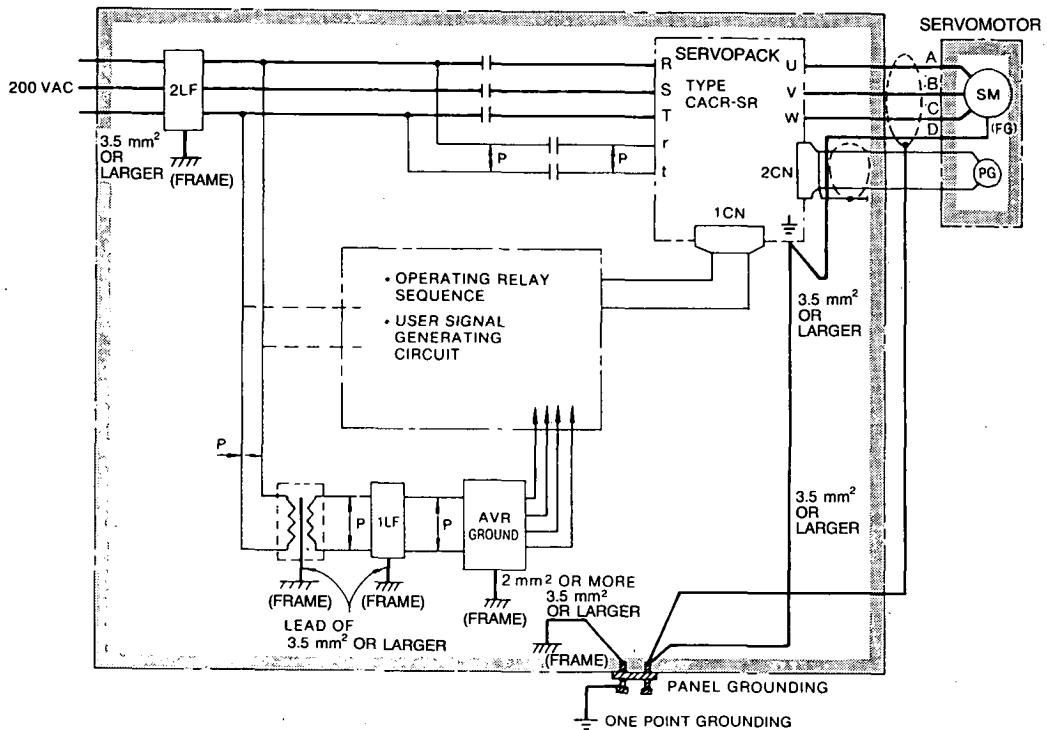

$\overline{P}$ : Twisted pair wires

Notes:

1. Use wires of 3.5mm<sup>2</sup> or larger for grounding to the case (preferably flat-woven copper wire).
2. Connect line filters observing the precautions as shown in (2), "Noise filter installation."

Fig. 6.12 Grounding Method

- Motor frame grounding

Motor ground terminal (E) (motor frame) should be connected to terminal (E) of SERVOPACK. (Terminal (E) of SERVOPACK should be directly grounded.).

- SERVOPACK SG 0 V

Noise may remain in the input signal line, so make sure to ground SG 0 V. When motor wiring is contained in metal conduits, the conduits and boxes must be grounded. The above grounding uses one-point grounding.

## (2) Noise filter installation

When noise filters are installed to prevent noise from the power line, the block type must be used. The recommended noise filters are shown in Table 6.2. The power supply to peripherals also needs noise filters.

### NOTE

If the noise filter connection is wrong, the effect decreases greatly. Observing the precautions, carefully connect them as shown in Figs. 6.13 to 6.16.

Table 6.2 Recommended Noise Filter

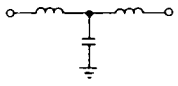
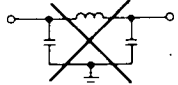
SERVOPACK Type CACR-	Applicable Noise Filter	Recommended Noise Filter	
		Type	Specifications
SR02BE SR03BE SR05BE		LF-305	Three-phase 200 VAC class, 5A
SR07BE		LF-310	Three-phase 200 VAC class, 10A
SR01BE SR15BE		LF-315	Three-phase 200 VAC class, 15A
SR20BE		LF-320	Three-phase 200 VAC class, 20A
SR30BE		LF-330	Three-phase 200 VAC class, 30A
SR44BE		LF-340	Three-phase 200 VAC class, 40A
SR60BE		LF-350	Three-phase 200 VAC class, 50A

Note: Noise filter made by Tokin Corp.

(a) Separate the input and output leads. Do not bundle or run them in the same duct.

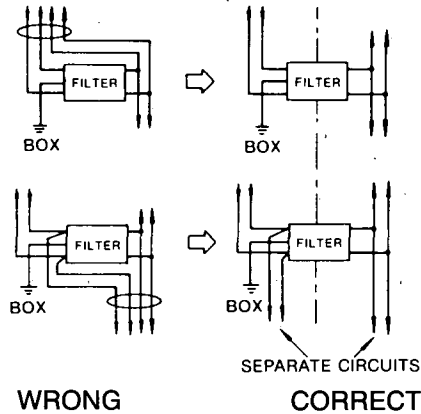

Fig. 6.13

(b) Do not bundle the ground lead with the filter output line or other signal lines or run them in the same duct.

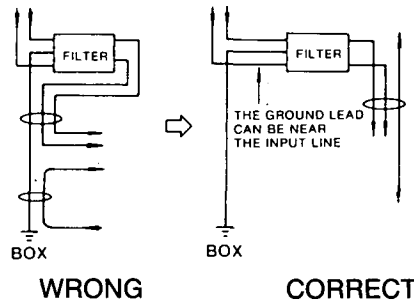

Fig. 6.14

(c) Connect the ground lead singly to the box or the ground panel.

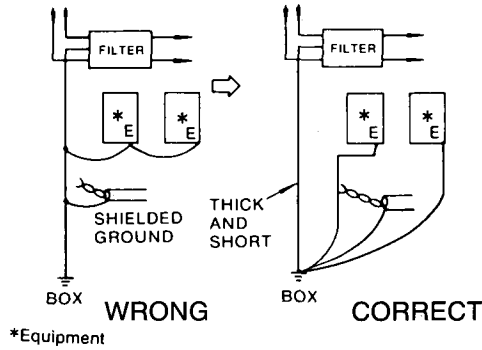

Fig. 6.15

(d) If the control panel contains the filter, connect the filter ground and the equipment ground to the base of the control unit.

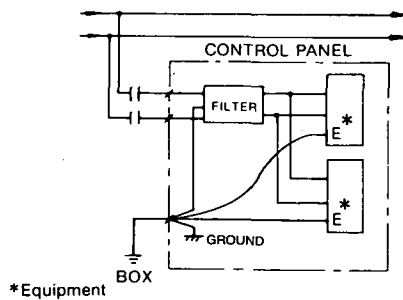

Fig. 6.16

## 6.7.2 Power Line Protection

SERVOPACK is operated through the commercial power line (200 V). To prevent the power line accidents due to grounding error, contact error, or to protect the system from a fire, circuit breakers (MCCB) or fuses must be installed according to the number of SERVOPACKS used (Table 6.3).

A fast-blow fuse cannot be used, because of the in-rush current.

Table 6.3 Power Supply Capacity and MCCB or Fuse Capacity

SERVOPACK Type CACR-	Power Capacity* per SERVOPACK	Current Capacity per MCCB or Fuse
SR02BE•SR03BE	0.65 kVA	5 A
SR05BE	1.1 kVA	5 A
SR07BE	1.5 kVA	8 A
SR10BE	2.1 kVA	8 A
SR15BE	3.1 kVA	10 A
SR20BE	4.1 kVA	12 A
SR30BE	6.0 kVA	18 A
SR44BE	8.0 kVA	24 A
SR60BE	11 kVA	32 A

\* Values at rated load.

## 6.8 APPLICATION

### 6.8.1 Connection for Reverse Motor Running

If the machine construction requires that the normal forward reference is used for reverse motor running and the normal reverse reference for forward running, short-circuit across 2CN-1 and 2CN-7 on the PG connector (2CN), or set bit 0 of user constant Cn-02 to 1. In this case, change of motor and PG connection is not required.

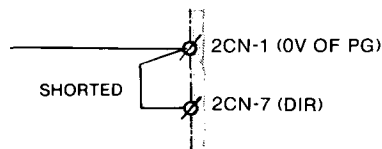
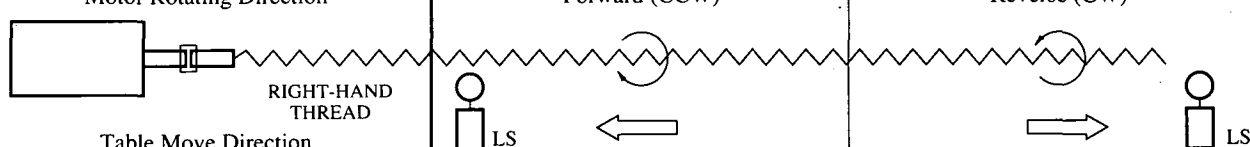
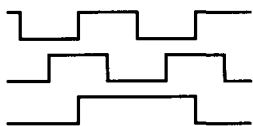
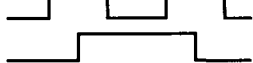
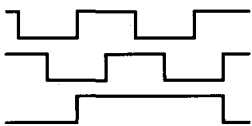
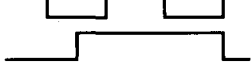

Fig. 6.17





As for the driver outputs from the SERVOPACK, phase-B precedes phase-A by 90 degrees when forward rotation reference is input.

Table 6.4 Motor Rotating Direction and I/O Signals

Running Mode (Standard)

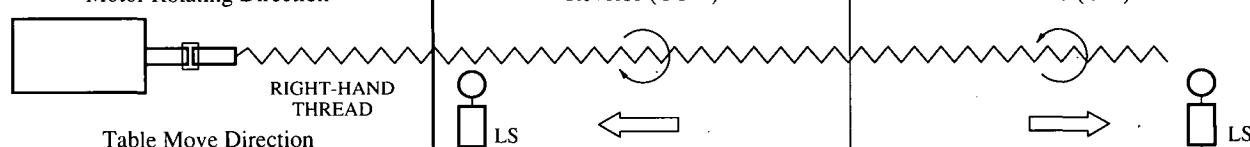
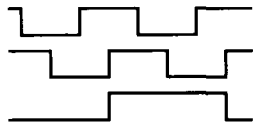
Speed Reference	Voltage input (plus)	Voltage input (minus)
Speed Monitor	Voltage output (minus)	Voltage output (plus)
Torque Reference Monitor	Voltage output (minus)	Voltage output (plus)
<p>Motor Rotating Direction</p>  <p>RIGHT-HAND THREAD</p> <p>Table Move Direction</p>	Forward (CCW)	Reverse (CW)
Effective Signal at Overtravel (OT)	P-OT	N-OT
Effective Signal at Current Limit Reference	P-CL (Minus voltage input)	N-CL (Plus voltage input)
<p>PG Feedback Output</p> <p>(After frequency dividing output)</p> <p>Dividing Ratio=1 : 1</p>	<p>Phase-A</p>  <p>Phase-B</p>  <p>Phase-C</p>	<p>Phase-A</p>  <p>Phase-B</p>  <p>Phase-C</p>

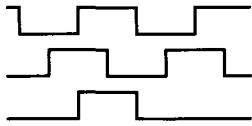
Running Mode (Reverse)

Speed Reference	Voltage input (minus)	Voltage input (plus)
Speed Monitor	Voltage output (plus)	Voltage output (minus)
Torque Reference Monitor	Voltage output (plus)	Voltage output (minus)
<p>Motor Rotating Direction</p>  <p>RIGHT-HAND THREAD</p> <p>Table Move Direction</p>	Reverse (CCW)	Forward (CW)
Effective Signal at Overtravel (OT)	N-OT	P-OT
Effective Signal at Current Limit Reference	N-CL (Plus voltage input)	P-CL (Minus voltage input)
<p>PG Feedback Output</p> <p>(After frequency dividing output)</p> <p>Dividing Ratio=1 : 1</p>	<p>Phase-A</p>  <p>Phase-B</p>  <p>Phase-C</p>	<p>Phase-A</p>  <p>Phase-B</p>  <p>Phase-C</p>

## 6.9 MOTOR SPEED AND TORQUE MEASUREMENT

Output level monitoring by DC voltmeter and output waveform check by oscilloscope can be performed.

When an instrument is connected to measure speed and torque, make the connection as shown in Fig. 6.18, using a DC ammeter of  $\pm 1$  mA (both swing).

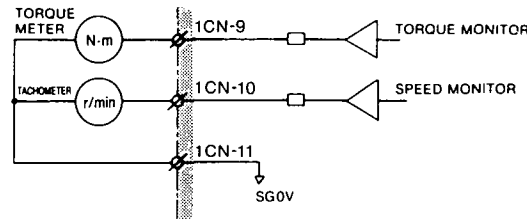
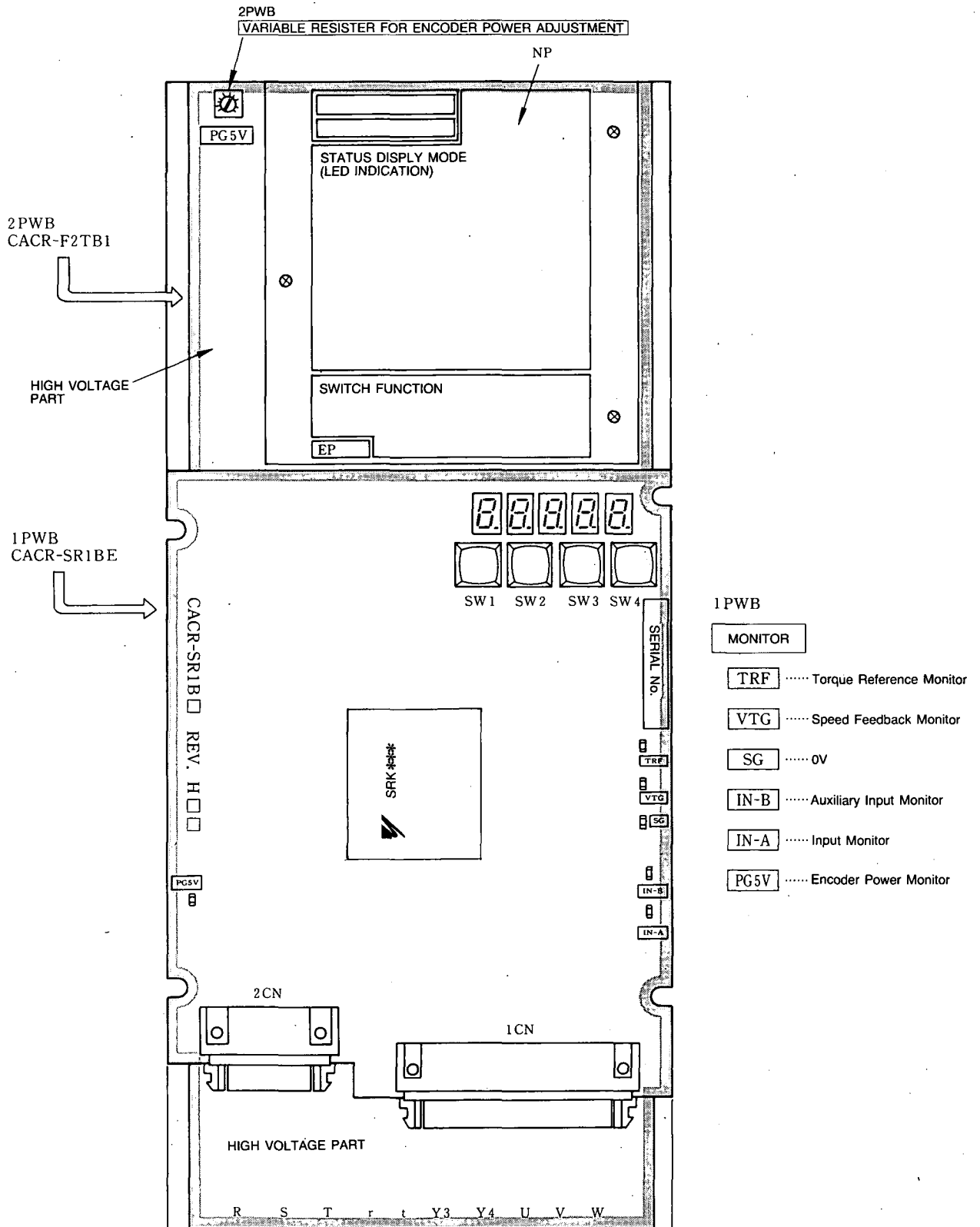

Fig. 6.18 Speed and Torque Measurement

### 6.9.1 Monitor Terminals

- Torque monitor output (1CN-9):  $\pm 3.0V \pm 10\% / \mp 100\%$  torque (M, F, G, S series)  
 $\pm 2.0V \pm 10\% / \mp 100\%$  torque (D series)
- Speed monitor output (1CN-10):  $\pm 4.0V \pm 5\% / \mp 1000$  r/min (M series)  
 $\pm 2.0V \pm 5\% / \mp 1000$  r/min (F, D, G, S series)
- Instrument:  $\pm 1$  mA (both swing) ammeter.  
Use ammeter of DCF-6 or DCF-12N or equivalent by Toyo Instrument or equivalent.
- Example: When an M series motor (rated speed: 1000 r/min) is used, and speeds are to be measured up to the maximum speed (2000 r/min), use  $\pm 8V$ (both swing) DC voltmeter.
- Input monitor **IN-A** :  $\pm$  rated speed /  $\pm 6V$
- Auxiliary input monitor **IN-B** :  $\pm$  rated speed /  $\pm 2V$  to  $\pm 10V$
- Encoder power monitor **PG5V** : Measure the voltage to encoder
- Variable resistor for encoder power adjustment: Adjusted to  $5.35V \pm 50mV$  prior to shipment. When encoder cable is 20m or longer, turn CW to increase the voltage. (Normally, adjustment is not required.)





\*: SRK\*\*\* represents a software version.

Fig. 6.18 Location of Switches and Check Terminals

## 6.9.2 Application of SERVOMOTORS with Holding Magnetic Brake

AC SERVOMOTORS with brake is held by the brake when it stops operation. Follow the procedures below for use.

(1) This brake locks at non-magnetization. Therefore, turn OFF the brake power supply when the motor stops. Should the brake work while the motor is rotating, the contact causes excessive abrasion and the brake may be defective in shorter period.

(2) The brake has delay time. For operation timing of ON/OFF, see Fig. 6.18.

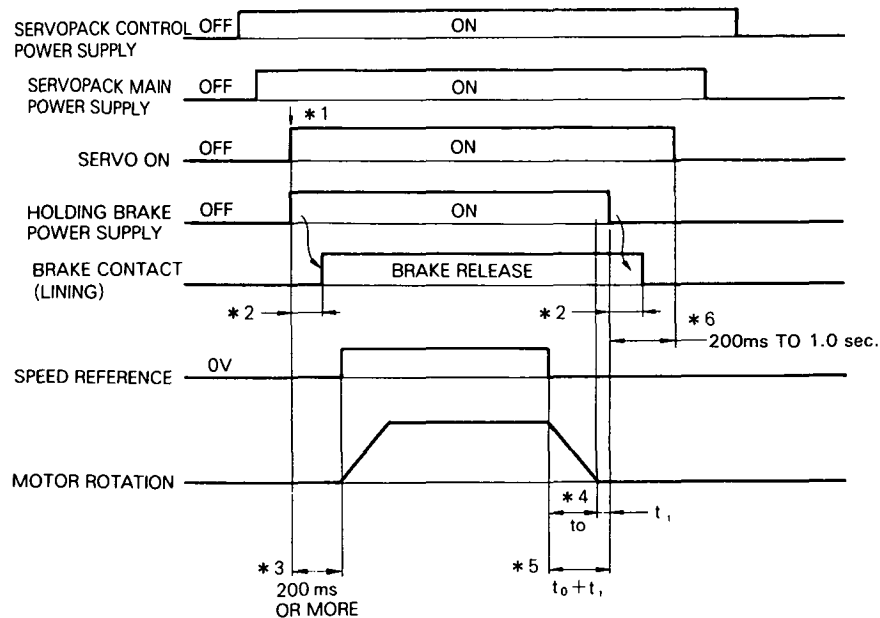

Fig. 6.18 Brake Timing

### Timing

- \*1 "Servo ON" and the holding brake power supply can be operated simultaneously.
- \*2 It takes a maximum of 180ms from when the brake power supply is ON till when mechanical contact is released. It takes a maximum of 100ms when the brake power supply is OFF.
- \*3 More than 200ms must be considered from when the brake power supply is ON till when speed reference is input.
- \*4  $t_0$  shows motor stopping time and is calculated as follows:

$$t_0 = 0.1047 \times \frac{(J_M + J_L) \times N_M}{(T_P + T_L)} \text{ (ms)}$$

$J_M (=GD_M^2/4)$ : Motor moment of inertia ( $\text{kg}\cdot\text{m}^2 = \text{lb}\cdot\text{in}\cdot\text{s}^2 \times 10^{-3}$ )

$J_L (=GD_L^2/4)$ : Load moment of inertia ( $\text{kg}\cdot\text{m}^2 = \text{lb}\cdot\text{in}\cdot\text{s}^2 \times 10^{-3}$ )

$N_M$ : Motor speed (r/min)

$T_P$ : Motor speed reduction torque (N·m)

$T_L$ : Load torque (N·m)

- \*5 Turn OFF the brake power supply when the motor stops. For normal operation,  $t_0 + t_1$  is approximately 1 to 2 seconds.
- \*6 Turn OFF "servo ON" 0.2 to 1.0 second after the brake power supply is turned OFF.

## 7. USER CONSTANTS

SERVOPACK offers the following user constants that can be set up and modified to fit the system requirements. Understand the functions of the constants before using them. For constant setup or adjustment, use the monitor panel (see Par. 8; "MONITOR PANEL OPERATIONS").

### (1) Speed Reference Adjustment Gain: Cn-03 **INBGN**

- IN-B input motor speed adjustment constant. Adjustment range is from 0 through 2000 r/min/V.
- For positioning control, the loop gain increases with an increase in this gain setting.
- Factory setting is rated speed/10 V.

### (2) Speed Loop Gain: Cn-04 **LOOPHZ**

- Speed controller proportional gain. Adjustment range is from 20 through 500 Hz (when used at an equivalent inertia.)
- Factory setting is 40 Hz.
- Actual speed loop gain =  $\frac{2 \times \text{Moment of inertia}}{\text{Moment of inertia} + \text{Load inertia}}$

Actual speed loop gain is limited to 100 Hz max. When load rigidity is low, decrease the speed loop gain.

### (3) Speed Loop Integration Time Constant: Cn-05 **PITIME**

- Speed controller integration time. Adjustment range is from 2 through 512 ms.
- Factory setting is 20 ms.

### (4) Emergency Stop Torque: Cn-06 **EMGTRQ**

- Overtravel stop braking torque setting (percentage of the motor's rated torque). Setting range is from 0 through the maximum torque. (100% = rated torque).
- It is possible to decelerate the motor at the set torque value, if the overtravel inputs P/N-OT are triggered (CN-26, 41, set bit 7 of Cn-01).
- Factory setting is the maximum torque.

### (5) Soft Start time: Cn-07 **SFSACC**

- This constant refers to the time required for the speed reference to change from 0 (r/min) to the maximum speed or from the maximum rotating speed to 0 (r/min). Setting range is from 0 through 10,000 ms.
- Factory setting is 0 ms.
- For positioning control, this constant should normally be set to 0 ms.

### (6) Forward Running Torque Limit: Cn-08 **TLMTF**

- Forward running motor torque limit. Setting range is from 0 through the maximum torque. (100% = rated torque)
- Factory setting is the maximum torque.

(7) Reverse Running Torque Limit: Cn-09 **TLMTR**

- Reverse running motor torque limit. Setting range is from 0 through the maximum torque. (100% = rated torque).
- Factory setting is the maximum torque.

(8) PG Dividing Ratio: Cn-0A **PGRAT**

- Number of detected (phase-A and-B) pulses per rotation sent from the PG (encoder) is converted to the pulse number according to the setting of this constant and is output to 1CN-33 to -36. (Also output to open collector output 1CN-4 and-37.)
- Set the number of output pulses per rotation. Setting range depends on the PG. See the following table.

Number of Encoder Pulses (P/R)	Dividing Pulse Set Value
2048, 8192	Any integer from 1 to PG pulse number
2500	1/N (n < 32, integer) 1/1 : 2500 P/R 1/2 : 1250 P/R 1/4 : 625 P/R 1/5 : 500 P/R 1/10 : 250 P/R 1/20 : 125 P/R 1/25 : 100 P/R

(9) Zero-Speed Level: Cn-0B (TGONLV)

- This is motor zero-speed determination level. Setting range is from 1 (r/min.) to the maximum speed.
- When the motor rotation speed exceeds the set value, sequence output TGON is turned ON (between 1CN-22 and -23 are "closed").
- Factory setting is 20 (r/min).

(10) Mode Switches

- The following constants are user for setting mode switch operating points. Detection points where PI control is switched to P control are set for improving transient characteristic of acceleration, deceleration and output saturation of the speed controller. Different levels can be set for three types of detection points for the mode switch.
- The detection points can be selected by setting bits of user constant Cn-01.

Detection Point	Bit Setting of Cn-01	Mode Switch Level	Unit
① Torque Reference (output from the speed controller)	Bit C = 0, Bit D = 0	Cn-0C (TRQMSW)	%
② Speed Reference	Bit C = 1, Bit D = 0	Cn-0D (REFMSW)	r/min
③ Detection of motor acceleration	Bit C = 0, Bit D = 1	Cn-0E (ACCMSW)	10 (r/min)/s
④ Mode Switch Disable	Bit C = 1, Bit D = 1		

(11) Zero-clamp Level: Cn-0F ZCLVL

- This is the motor rotation speed level which zero-clamp is performed. Setting range is from 0 to 100 (r/min).
- During speed control with zero-clamp (Cn-01 bit A = 1, bit B = 0), if contact input  $\overline{P-CON}$  is ON when the motor rotation speed (SRK006), or motor speed reference (SRK008 or later) drops to the set value or lower, speed reference is disconnected and the motor speed is reduced to zero. After the motor is stopped, servo lock status is maintained.

Note: SRK006 and SRK008 represent a software version.

(12) Jog Speed: Cn-10 JOGSPD

- Set up jog speed. Setting range is from 0 r/min. to the maximum speed.
- To start jogging, enter the operation reference from the setting panel.
- Factory setting is 100 (r/min).

(13) Encoder pulse Number: Cn-11 PULSNO

This is the number of pulses per rotation of the motor encoder. Set the value corresponding to the encoder. Don't change this setting.

(14) Delay Time from Brake Reference Output to SVOFF Operation: Cn-12 BRKTIM

- This is delay time from the output of brake reference to the actuation of SVOFF for a motor with a brake. Setting range is from 0 to 50 ( $\times 10\text{ms}$ ). Factory setting is 20 ( $\times 10\text{ms}$ ).
- This setting outputs the brake timing signal from TGON output only when bit E of user constant Cn-01 is 1.

(15) Brake Timing at Motor Running (speed): Cn-15 BRKSPD

- This is speed level (r/min) to output the brake reference.
- The setting range is 0 to the maximum speed (r/min).
- Factory setting is 100 (r/min).
- This setting outputs the brake timing signal from TGON output only when bit E of user constant Cn-01 is 1.

(16) Brake Timing at Motor Running (Time): Cn-16 BRKWAI

- This is dwell time from SVOFF to brake reference output.
- Setting range is 10 to 100 ( $\times 10\text{ms}$ ).
- Factory setting is 50 ( $\times 10\text{ms}$ ).
- This setting outputs the brake timing signal from TGON output only when bit E of user constant Cn-01 is 1.

(17) Torque Reference Gain: Cn-13 TCRFGN

- Set the torque reference input level in torque control mode.
- Setting range is 10 to 100 (1/10V/rated torque).
- Factory setting is 30 (1/10V/rated torque).

(18) Speed Limit at Torque Control I: Cn-14 **TCRLMT**

- Setting range is 0 to the maximum speed (r/min).
- Factory setting is the maximum speed (r/min).

(19) Torque Reference Filter: Cn-17 **TRQFIL**

- Increase the filter when torsional vibration occurs since the load rigidity is low. Note that too big filter setting degrade the servo performance.
- Setting range is 4 to 250 ( $\times 100 \mu\text{s}$ ).

(20) Selection of Sequence Inputs, Reference Signal Error Stop Methods, Control Modes, and Mode Switches

Use user constant Cn-01 memory switches for the above selection. (For the assignment and explanation of the memory switches, See Table 8.5, "User Constant Cn-01 List.")

See sequences (a), (b) and select an error stop method fit for the system.

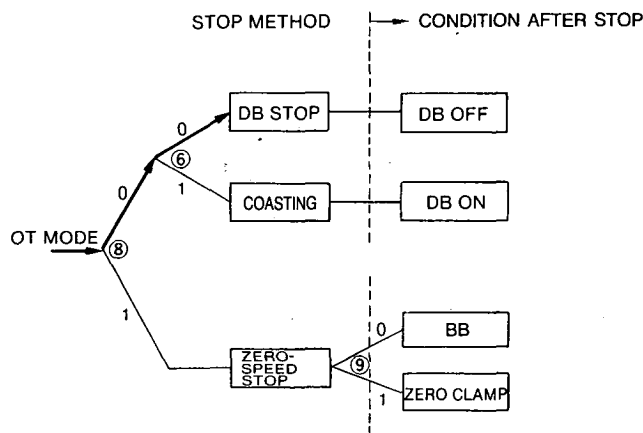

(a) Sequence on OT mode

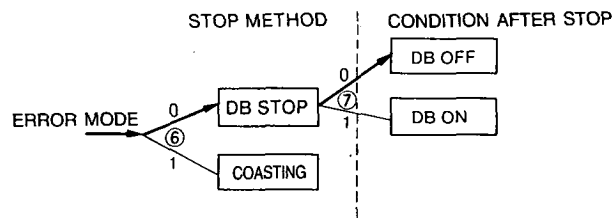

(b) Sequence on fault mode (except OT mode)

Note: Numbers in a circle indicate bit numbers of Cn-01. Arrows indicate standard setting.

Fig. 7.1 Error Stop Sequences

# 8. MONITOR PANEL OPERATION

## 8.1 SWITCH OPERATION

Fig. 8.1 shows the monitor panel. Operating control switches SW1 through SW4 are used to execute the f·1 through f·7 functions. Functions f·1 through f·7 vary with monitor panel mode.

Notes:

1. The monitor panel's constant setup data is retained even after the power is turned OFF.
2. Even if the power is turned OFF after fault occurrence, the fault data is retained in memory. Therefore, it is possible to check the fault data after the power is turned back ON.
3. The monitor mode can be changed even during operations.

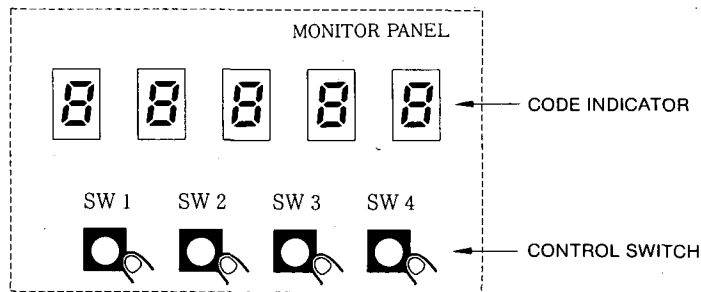
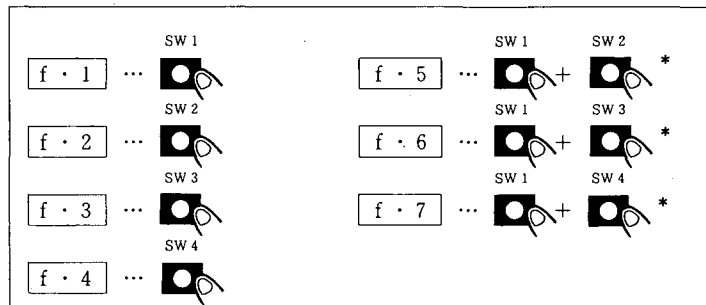

Fig. 8.1 Monitor Panel



\*Depress both switches simultaneously.

Fig. 8.2 Description of Switch Function

## 8.2 MONITOR PANEL FUNCTIONS

Table 8.1 shows the monitor panel functions. The status display is the default when control power is turned ON. To change the mode, use switch SW4 as shown in Fig. 8.3.

Table 8.1 Monitor Panel Functions

Mode	Function
State Indication Mode	Various Status Indiction • Base Block • On Operation • Fault For details, refer to Table 8.2
Setting Mode	Refer to "User Constant Setting." • Operation (JOG) from Monitor Panel • Speed Reference Offset Adjustment
Monitor Mode	Various Monitoring • Speed • Speed Reference • Torque Reference • Number of Pulses from Origin (Phase-U) • Electrical Angle • Interior Status Bit
Fault Traceback Indication Mode	Fault History

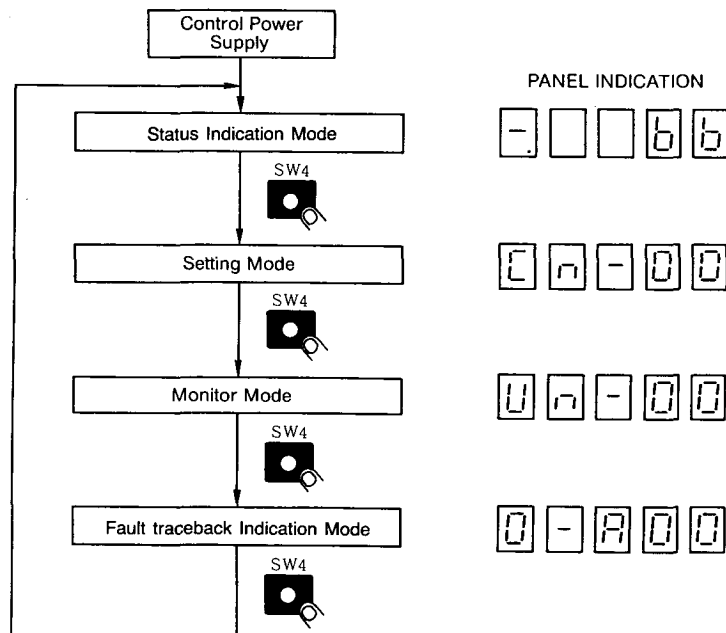

Fig. 8.3 Mode Changeover



### 8.3 STATUS INDICATION MODE

When this mode is selected, the condition of SERVOPACK is indicated with bit and code as shown in Fig. 8.4. Fig. 8.2 shows the bits and the conditions. Fig. 8.5 shows the function allocations of switches.

**RST** : Becomes alarm reset switch.

**SET** : Changes status indication mode into setting mode.

#### Panel Display

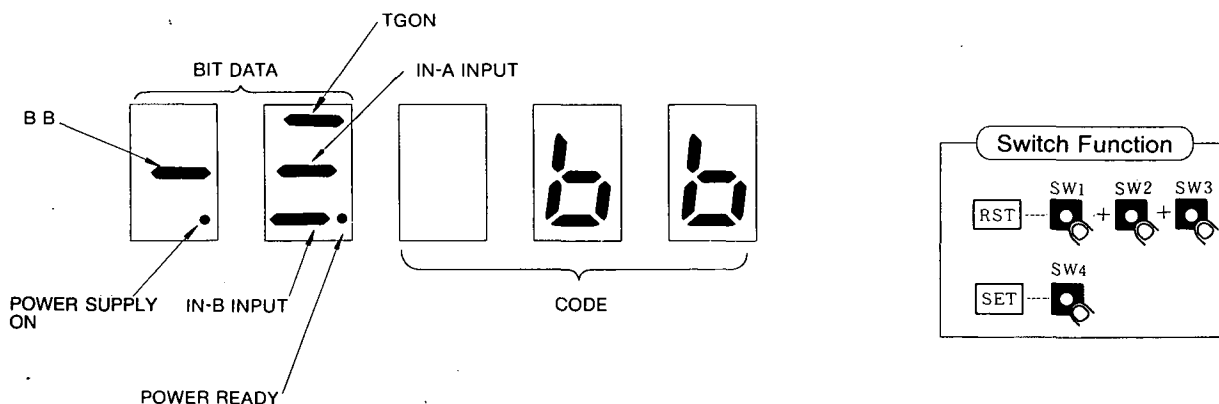

Fig. 8.4 Status Indication Mode

Table 8.2 Bit Data Contents

Bit Data	Contents
Power Supply ON	Light goes ON with control power supply ON.
BB	Light goes ON with base block, and goes OFF with servo ON.
TGON	Light goes ON with motor speed higher than TGON level (standard setting is 20 r/min).
IN-A Input	Light goes ON with IN-A input higher than TGON level.
IN-B Input	Light goes ON with IN-B input higher than TGON level.
Power Ready	Light goes ON with main power ON.

Table 8.3 Codes and Status

Code	Status
<i>bb</i>	Base Block
<i>run</i>	On Operation
<i>For</i>	Forward Running Prohibited
<i>ror</i>	Reverse Running Prohibited
<i>A. 00</i>	Alarm Contents Refer to Table 8.9.
<i>A. 01</i>	
<i>!</i>	

Note: A.10 (overcurrent) cannot be reset.  
Turn OFF the power and check the wiring to turn ON the power again.

## 8.4 SETTING MODE

In this mode, the following operations can be performed.

- User constant setup and monitor
- Jog operations from the monitor panel
- Speed reference offset adjustment
- Fault traceback data clearing

### 8.4.1 User Constant (Data) Setup and Monitor (Cn-03 to Cn-17)

The switch functions are indicated in Fig. 8.5.

Panel Display

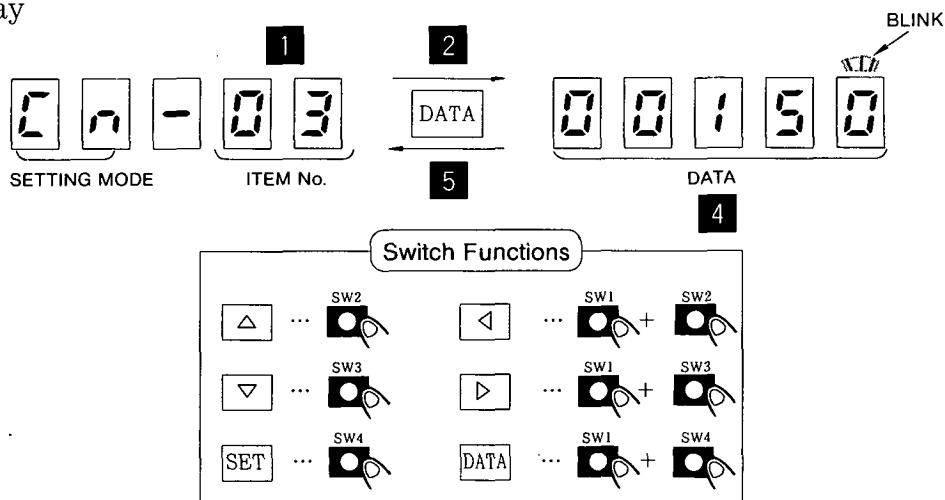

Fig. 8.5 Switch Functions for User Constant Setting

- Set up the item number with the ▲, ▼, ◀, and ▶ keys.
  - With the ◀ and ▶ keys, choose a setup digit. The chosen digit then starts blinking to indicate that its numerical value can be changed.
  - With the ▲ and ▼ keys, increase or decrease the numerical value until the desired value is obtained.
- With the DATA key, display the data related to the selected item number.
- With the ▲, ▼, ◀, and ▶ keys, set up the data.
- Retain the data with the SET key.
- With the DATA key, return to the item No. display status.
- Repeat steps 1 through 5 as needed.
- Using the SET key, switch from the setting mode to the monitor mode.

Table 8.4 User Constants Cn-03 through Cn-12 (Constant Setting) List

	User Constant	Symbol	Name	Unit	Lower Limit	Upper Limit	Setting prior to Shipmernt	Remarks
Gain Constants	Cn-03	INBGN	Speed Reference Adjustment Gain	(r/min)/V	0	3000	Rated Speed / 10V	SRK006*
					10			SRK008 or later
	Cn-04	LOOPHZ	Speed Loop Gain	Hz	20	500	40	SRK006
					1			SRK008 or later
	Cn-05	PITIME	Speed Loop Integration Time	ms	2	512	20	SRK006
1000						SRK008 or later		
Torque Constants	Cn-06	EMGTRQ	Emergency Stop Torque	%	0	Max Torque	Max Torque	OT Mode <sup>Note</sup>
	Cn-08	TLMTF	Forward Running Torque Limit	%	0	Max Torque	Max Torque	<sup>Note</sup>
	Cn-09	TLMTR	Reverse Running Torque Limit	%	0	Max Torque	Max Torque	<sup>Note</sup>
	Cn-13	TCRFGN	Torque Reference Gain	$\frac{1}{10} V / \text{Rated Torque}$	10	100	30	Torque control mode
	Cn-14	TCRLMT	Speed Limit with Torque Control I	r/min	0	Max Speed	Max Speed	
	Cn-17	TRQFIL	Torque Reference Filter Time	100 $\mu$ s	0	250	4 (20) <sup>†</sup>	
Sequence Constants	Cn-07	SFSACC	Soft Start Time (Acceleration)	ms	0	10000	0	Up to Max. speed
	Cn-0B	TGONLV	Zero-speed Level	r/min	1	Max Speed	20r/min	TGON output
	Cn-0F	ZCLVL	Zero-clamp Level	r/min	0	100	10	Zero clamp function
	Cn-12	BRKTIM	Delay Time from Braking Reference to SVOFF	10ms	0	50	20	
	Cn-15	BRKSPD	Brake Timing at Motor Rotation (Speed level at which brake reference is output.)	r/min	0	Max Speed	100	Brake reference function
	Cn-16	BRKWAI	Brake Timing at Motor Rotation (Waiting time from SVOFF to brake reference output.)	10ms	10	100	50	
Other Constants	Cn-0A	PGRAT	PG Dividing Ratio	P/R	1	Encoder Number of Pulses	Encoder Number of Pulses	‡
	Cn-11	PULSNO	Number of Encoder Pulses	P/R	—	—	Encoder Number of Pulses	#
	Cn-0C	TRQMSW	Mode Switch (Torque Reference)	%	0	Max Torque	200	<sup>Note</sup>
	Cn-0D	REFMSW	Mode Switch (Speed Reference)	r/min	0	Max Speed	0	
	Cn-0E	ACCMSW	Mode Switch (Motor Acceleration Detection)	10 (r/min)/s	0	3000	0	
	Cn-10	JOGSPD	JOG Speed	r/min	0	Max Speed	100	

Notes: 1. 100% = rated torque

2. For max. speed and max. torque, refer to Par. 1.6. "RATINGS AND SPECIFICATIONS".

\*SRK006 and SRK008 or later represent a software versions. Functions may differ depending on a software version.

† For types CACR-SR10BE1□F, SR15BE1□F, SR15BE1□G, SR10BY1□F, SR15BY1□F, SR15BY1□G.

‡ After modifying Cn-0A (PG dividing ratio setting), turn OFF power and start up again. The modified value takes effect only after restarting.

# Don't change the value set prior to shipment.

## 8.4.2 User Constant (Memory Switch) Setup and Monitor (Cn-01 and Cn-02)

User constant Cn-01 can be set up or monitored as memory switch bits. The procedures for item number setup and data display are the same as indicated in Par. 8.4.1.

The switch functions provided after bit data display are indicated in Fig. 8.6.

### Panel Display

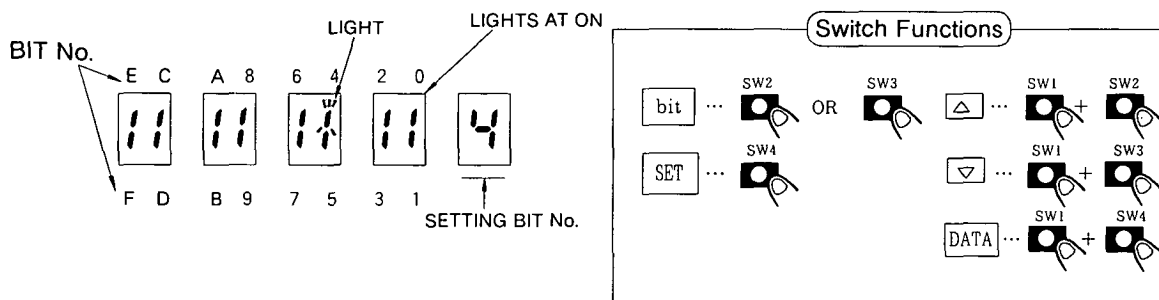

Fig. 8.6 Switch Functions Provided after Bit Data Display

- 1** With the  $\Delta$  and  $\nabla$  keys, enter the setup memory switch number at the far right end of the panel.
- 2** With the  $\text{bit}$  key, set the memory switch to ON or OFF (either switch SW2 or SW3 can be used). The panel indication comes on when the switch is ON, and goes off when the switch is OFF.
- 3** Repeat steps **1** and **2** as needed.
- 4** With the  $\text{SET}$  key, data is retained.
- 5** With the  $\text{DATA}$  key, return to the item No. display status.
- 6** Using the  $\text{SET}$  key, switch from the setting mode to the monitor mode.

Table 8.5 User Constant Cn-01 (Memory Switch) List

Selection	Bit No.	Setting	Conditions	Standard
Sequence Input Selection	0	0	Servo ON/OFF by external input (SV-ON).	0
		1	The servo is ON at all times. Don't change.	
	2	0	The P-OT signal prohibits forward running.	0
		1	Forward running is permitted at all times.	
	3	0	The N-OT signal permits reverse running.	0
		1	Reverse running is permitted at all times.	
Input Signal Selection	4	0	IN-A input is used.	0
		1	Regardless of the IN-A input presence, SERVOPACK concludes that IN-A input is 0.	
	5	0	IN-B input is used.	0
		1	Regardless of the IN-B input presence, SERVOPACK concludes that IN-B input is 0.	
Fault Stop Selection	6	0	<DB stop> The dynamic brake stops the motor.	0
		1	<Coasting to a stop> The motor is freed and brought to a stop.	
	7	0	<DB OFF after DB stop> The dynamic brake is turned OFF after the motor is stopped.	0
		1	<DB continuously ON after DB stop> The dynamic brake remains activated after the motor is stopped.	
	8*	0	The overtravel status stop method coincides with bit 6.	0
		1	<Overtravel zero speed stop> In the overtravel status, the motor is stopped at the torque setting defined by user constant Cn-06.	
		9 †	0	
			1	In the overtravel status, zero clamping is effected after the motor stops.
Mode Switch Selection	D•C ‡	0•0	<Torque reference> Based on the torque reference level defined by user constant Cn-0C.	00
		0•1	<Speed reference> Based on the speed reference level defined by user constant Cn-0D.	
		1•0	<Acceleration> Based on the acceleration level defined by user constant Cn-0E.	
		1•1	<None> The mode switch function is not provided.	
External Brake	E	0	Brake reference function is not provided.	0
		1	Brake reference function is provided.	
Overload (OL) Warning Function	F#	0	Overload warning function is not provided.	0
		1	Before OL alarm occurs, TGON output becomes High (output TrOFF) after 20% of the time of OL alarm occurrence. TGON(running detection) cannot be performed.	

Note: When the setting of user constant Cn-01 is changed, turn OFF the power supply once and restart the operation.

\* The fault stop method in the torque control mode complies with bit 6.

† Selects the status based on the stop method selected for the overtravel status (bit 8).

‡ Selects the mode switch operating condition. When the mode switch operates, the speed control mode changes from P-I control to P control. (Effective only for speed control)

# Only for software version SRK008 or later.

Table 8.5 User Constant Cn-01 (Memory Switch) List (Cont'd)

Selection	Bit.No.	Setting	Description	Reference Input	Sequence Signal Input	Standard
Control Mode Selection	B • A	0 • 0	<p>&lt;Speed control&gt;</p> <ul style="list-style-type: none"> <li>Regular speed control.</li> <li>The <math>\overline{P-CON}</math> signal (1CN-24) is used to effect P/PI control changeover.</li> </ul>	Speed reference (IN-A) Auxiliary speed reference (IN-B)	$\overline{P-CON}$ OFF: PI control ON: P control	0 • 0
		0 • 1	<p>&lt;Zero clamp speed control&gt;</p> <ul style="list-style-type: none"> <li>After the motor is stopped (ZCLVL), the speed reference is disconnected to execute the zero speed stop function.</li> <li>The <math>\overline{P-CON}</math> signal (1CN-24) is used to turn the zero clamp function ON and OFF.</li> </ul>		$\overline{P-CON}$ OFF: Zero clamp function OFF ON: Zero clamp function ON	
		1 • 0	<p>&lt;Torque control I&gt;</p> <ul style="list-style-type: none"> <li>The motor output torque is controlled by the torque reference (IN-A).</li> <li>The IN-B cannot be used.</li> </ul>	Torque reference (IN-A)	None	
		1 • 1	<p>&lt;Torque control II&gt;</p> <ul style="list-style-type: none"> <li>The <math>\overline{P-CON}</math> signal (1CN-24) is used for torque/speed control mode changeover.</li> </ul> <p>Torque control mode</p> <ul style="list-style-type: none"> <li>The motor output torque is controlled by the torque reference (IN-B).</li> <li>The speed limit can be entered from outside (IN-A). The IN-A voltage (+) limits both the forward and reverse running speeds.</li> </ul> <div style="text-align: center;"> </div> <p>Speed control mode</p> <ul style="list-style-type: none"> <li>The speed reference is entered from the IN-A.</li> <li>The IN-B cannot be used.</li> </ul>	<p>At torque control</p> <p>Torque reference: (IN-B) Speed reference: (IN-A)</p> <p>At speed control</p> <p>Speed reference: (IN-A)</p> <p>Notes:</p> <ul style="list-style-type: none"> <li>If speed goes beyond the limit negative feedback of torque in proportion to speed difference from limit speed occurs to restore moderate speed. Therefore, width of actual motor rotation speed limit depends on load conditions.</li> </ul>	$\overline{P-CON}$ OFF: Torque control ON: Speed control	

Table 8.6 User Constant Cn-02 (Memory Switch) List

Selection	Bit No.	Setting	Description	Standard
Reverse Rotation Mode	0	0	CCW: Forward running	0
		1	CW: Forward running	
—	1 to F		Don't change.	

Note: After setting of Cn-02, turn OFF power and start up again.  
The modified data takes effect only after restarting.

### 8.4.3 Monitor Panel Jog Operation Mode Selection and Operating Procedure

#### (1) Monitor Panel Jog Operation Mode Selection

When user constant Cn-00 is set to 00, the operations are to be controlled from the monitor panel. The switch functions are indicated in Fig. 8.7.

#### Panel Display

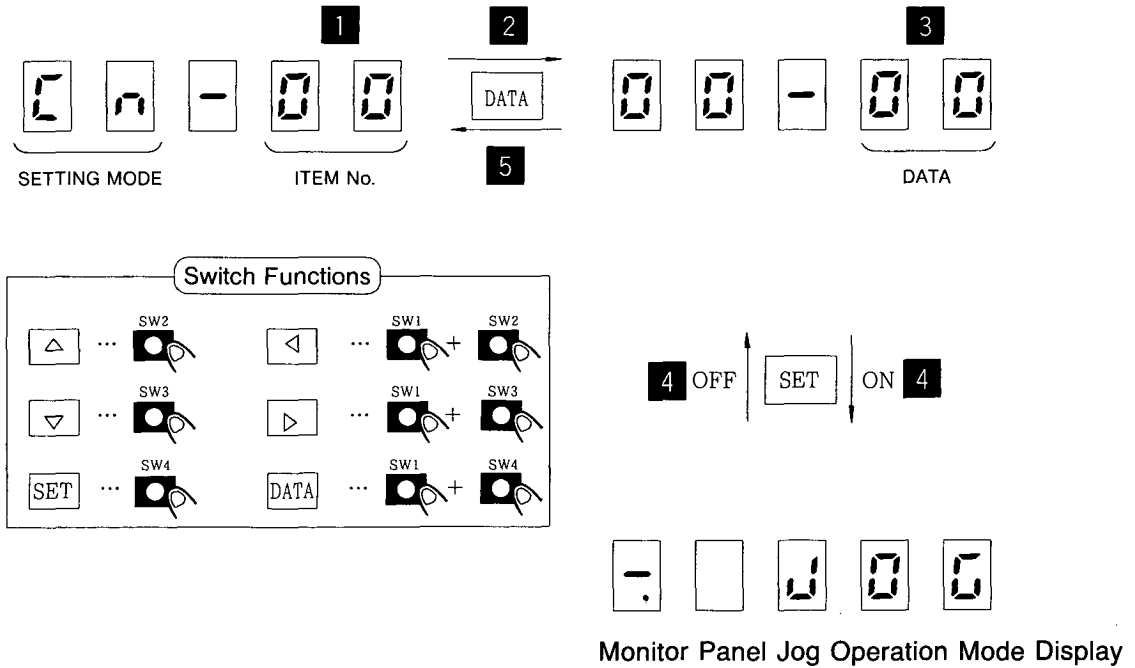

Fig. 8.7 Switch Functions in Monitor Panel Jog Operation Mode

- 1 Select the item number 00 with the  $\triangle$  ,  $\nabla$  ,  $\triangleleft$  and  $\triangleright$  keys.
- 2 With the  $\text{DATA}$  key, display the data related to the selected item number.
- 3 With the  $\triangle$  ,  $\nabla$  ,  $\triangleleft$  and  $\triangleright$  keys, select the number 00.
- 4 With the  $\text{SET}$  key, turn ON or OFF the monitor panel jog operation mode.
- 5 With the  $\text{DATA}$  key, return to the item No. display status.
- 6 Using the  $\text{SET}$  key, switch from the setting mode to the monitor mode.



## (2) Monitor Panel Jog Operation Procedure

For speed reference adjustment, use user constant Cn-10 (see Par. 8.4.1).

The switch functions provided for monitor panel jog operations are indicated in Fig. 8.8.

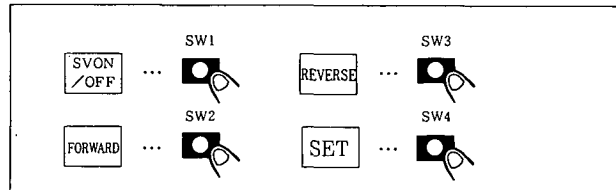

Fig. 8.8 Switch Functions for Monitor Panel Controlled Operations

- 1** With the **SVON/OFF** switch, effect SVON/SVOFF changeover.
- 2** The motor runs in the forward direction while the **FORWARD** key is held down.
- 3** The motor runs in the reverse direction while the **REVERSE** key is held down.
- 4** The **SET** key is used to switch from the monitor panel jog operation mode to the user constant Cn-00 data display status.
- 5** With the **DATA** key, return to the item No. display status.
- 6** Using the **SET** key, switch from the setting mode to the monitor mode.

### 8.4.4 Speed Reference Offset Adjustment

When user constant Cn-00 is set to 01, the system enters the speed reference offset adjustment mode. The switch functions are indicated in Fig. 8.9.

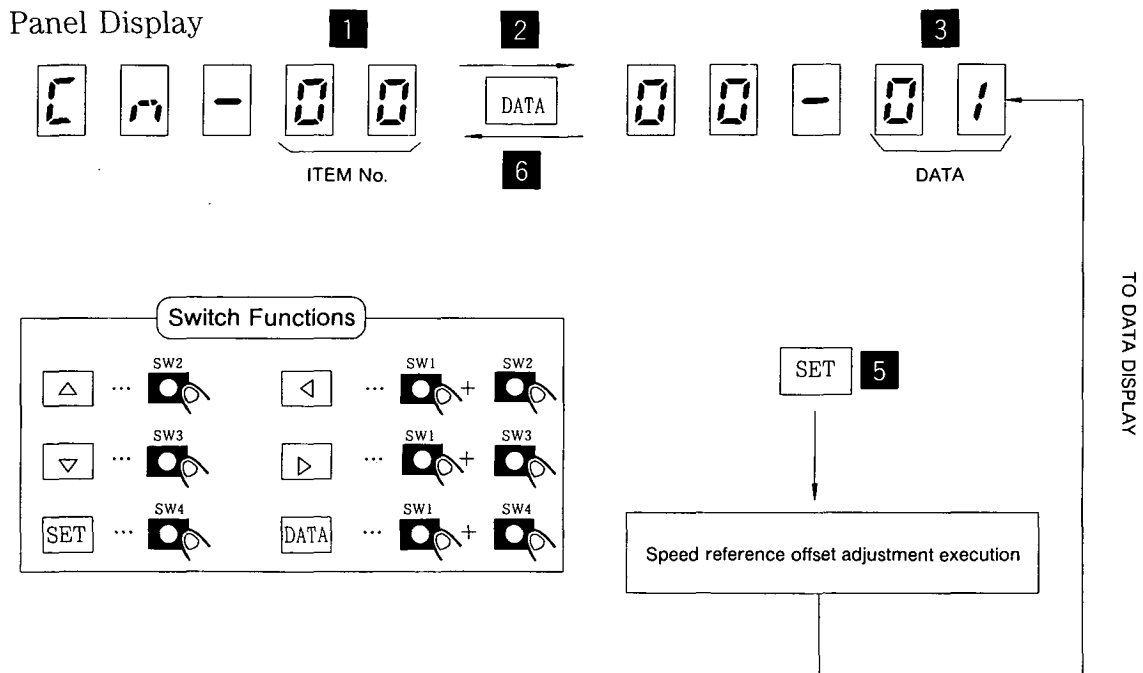

Fig. 8.9 Speed Reference Offset Adjustment

- 1 Select the item number 00 with the  $\Delta$  ,  $\nabla$  ,  $\leftarrow$  and  $\rightarrow$  keys.
- 2 With the  $\boxed{\text{DATA}}$  key, display the data related to the selected item number.
- 3 With the  $\Delta$  ,  $\nabla$  ,  $\leftarrow$  and  $\rightarrow$  keys, select the number 01.
- 4 Apply a desired zero speed reference voltage with speed reference input terminals IN-A and IN-B (a voltage of 0V should normally be applied).
- 5 With the  $\boxed{\text{SET}}$  key, make speed reference offset adjustment and return to the user constant Cn-00 data display status.
- 6 With the  $\boxed{\text{DATA}}$  key, return to the item No. display status.
- 7 Using the  $\boxed{\text{SET}}$  key, switch from the setting mode to the monitor mode.

Note: Speed reference offset adjustment range differs depending on the software version.  
 $\pm 10\text{mV}$  ... Software version SRK006  
 $\pm 50\text{mV}$  ... Software version SRK008 or later

### 8.4.5 Clearing Fault Traceback Data

When user constant Cn-00 is set to 02, fault traceback data are cleared. The switch functions are indicated in Fig. 8.10.

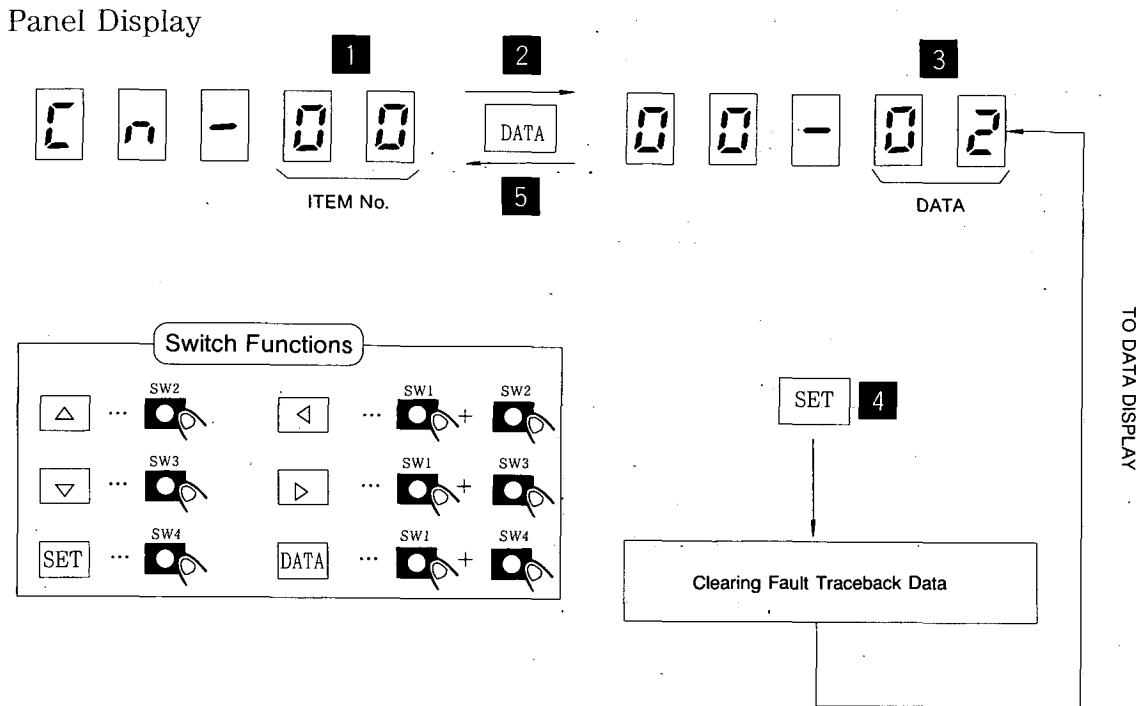

Fig. 8.10 Clearing Fault Traceback Data

- 1** Select the item number 00 with the  $\Delta$  ,  $\nabla$  ,  $\triangleleft$  and  $\triangleright$  keys.
- 2** With the  $\boxed{\text{DATA}}$  key, display the data related to the selected item number.
- 3** With the  $\Delta$  ,  $\nabla$  ,  $\triangleleft$  and  $\triangleright$  keys, select the number 02.
- 4** With the  $\boxed{\text{SET}}$  key, clear fault traceback data and return to the user constant Cn-00 data display status.
- 5** With the  $\boxed{\text{DATA}}$  key, return to the item No. display status.
- 6** Using the  $\boxed{\text{SET}}$  key, switch from the setting mode to the monitor mode.

## 8.4.6 Speed Reference Offset Manual Adjustment

### (1) Mode Setting in Speed Reference Offset Manual Adjustment

When user constant Cn-00 is set to 03, the system enters the speed reference offset manual adjustment mode. The switch functions are shown in Fig. 8.11.

Panel Display

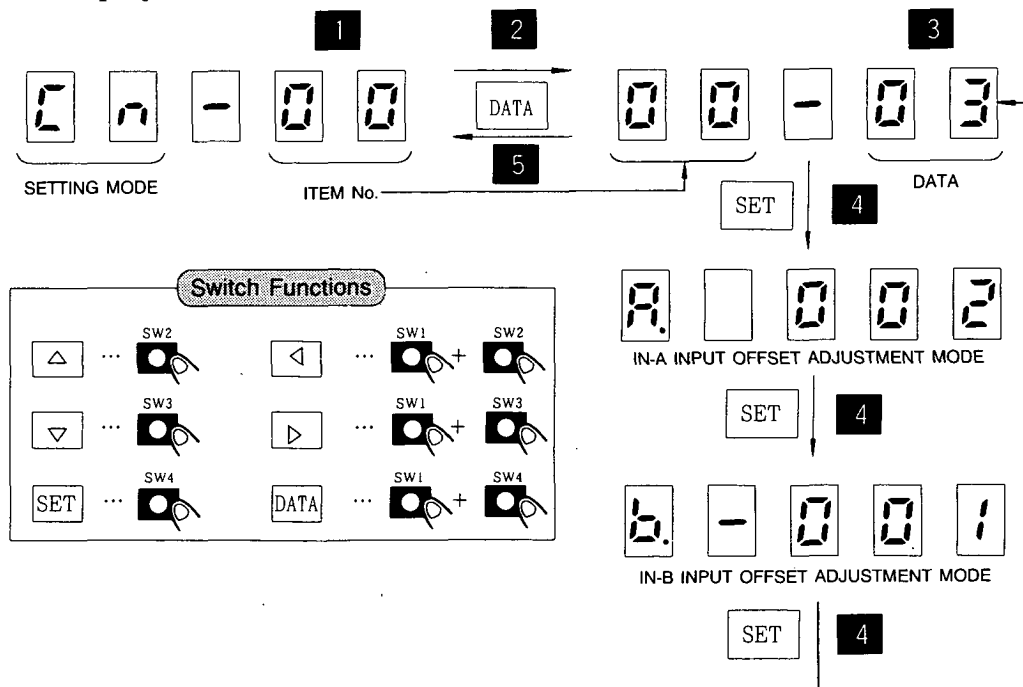

Fig. 8.11 Switch Functions in Speed Reference Offset Manual Adjustment Mode

- 1** Select the item number 00 with **△** , **▽** , **◀** and **▶** keys.
- 2** With the **DATA** key, display the data related to the selected item number.
- 3** With the **△** , **▽** , **◀** and **▶** keys, select the number 03.
- 4** With the **SET** key, switch the adjustment mode.
- 5** With the **DATA** key, return to the item No. display status.
- 6** Using the **SET** key, switch from the setting mode to the monitor mode.

Note: Speed reference offset adjustment range differs depending on the software version.  
 $\pm 10\text{mV}$  ... Software version SRK006  
 $\pm 50\text{mV}$  ... Software version SRK008 or later

## (2) Speed Reference Offset Manual Adjustment

Input a voltage that will obtain zero speed reference to the speed reference input terminals IN-A and IN-B (Normally 0V).

The switch functions in the reference offset manual adjustment mode are shown in Fig. 8.12.

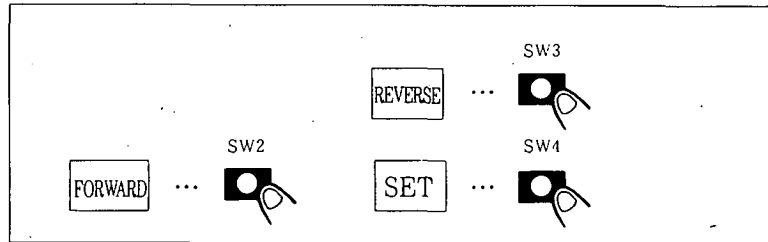

Fig. 8.12 Switch Functions in Speed Reference Offset Manual Adjustment Mode

- 1** While the **FORWARD** key is held down, the offset is added to the forward running side.
- 2** While the **REVERSE** key is held down, the offset is added to the reverse running side.
- 3** Use the **SET** key, store offset data, then enter the next mode.

Offset adjustment is performed so that the LED indication may basically become zero; however, the perfect zero status of indication does not always offer optimum adjustment. Therefore, adjust the offset carefully, taking actual motor motion into consideration.

## 8.4.7 Current Detection Offset Manual Adjustment

### (1) Mode Setting in Current Detection Offset Adjustment

When user constant Cn-00 is set to 04, the system enters the current detection offset adjustment mode. The switch functions are shown in Fig. 8.13.

#### Panel Display

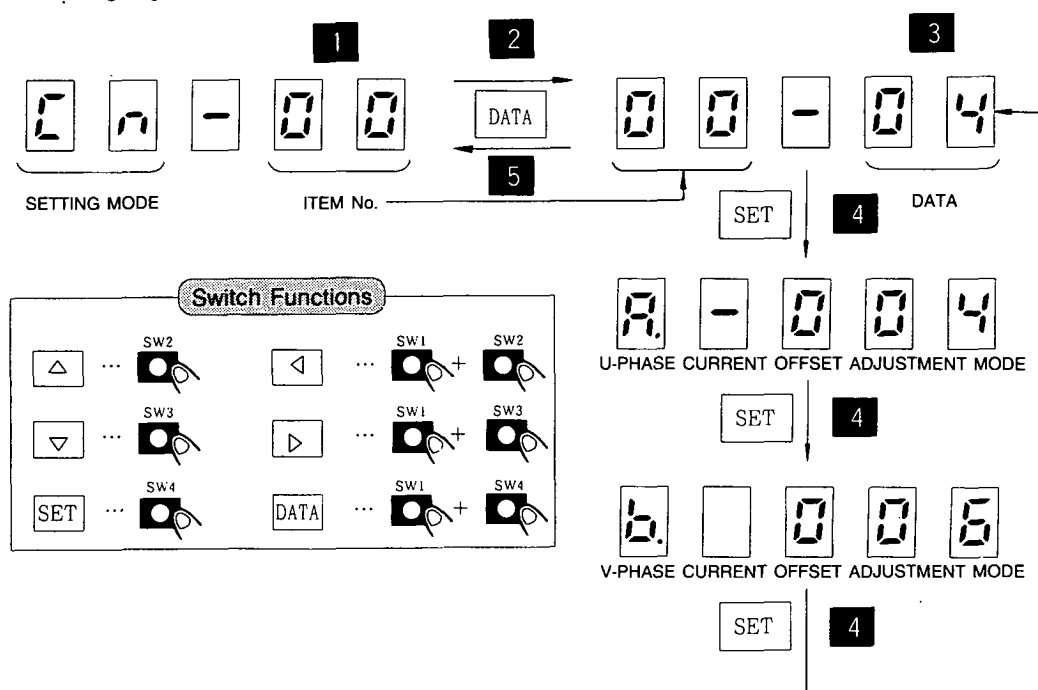

Fig. 8.13 Switch Functions in Current Detection Offset Adjustment Mode

- 1** Set up item number 00 with , , and keys.
- 2** With the key, display the data related to the selected item number.
- 3** With the , , and keys, select the number 03.
- 4** With the key, switch the adjustment mode.
- 5** With the key, return to the item No. display status.
- 6** Using the key, switch from the setting mode to the monitor mode.

## (2) Current Detection Offset Adjustment

The current detection offset is adjusted at the factory prior to shipment: the user, in principal, doesn't need to adjust it.

However, if adjustment of higher accuracy is required due to a SERVOPACK-motor combination, perform adjustment as follows:

The switch functions in the current detection offset adjustment mode are shown in Fig. 8.14.

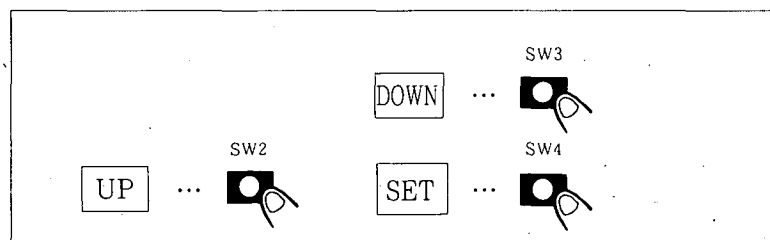

Fig. 8.14 Switch Functions in Current Detection Offset Adjustment Mode

- 1** Rotate the motor at about 100 r/min, and monitor the torque monitor terminal MON1 using an oscilloscope.
- 2** Depressing the  or  key, perform adjustment so as to have a minimum torque ripple. LED indication shows offset data.
- 3** With the  key, store offset data, then enter the next mode.
- 4** Because torque ripple must be adjusted with a good balance between U-phase and V-phase offsets, repeat steps **2** and **3** several times, to make sure of an optimum value.

## 8.4.8 Check of Motor Parameters

### (1) Check Method of Motor Parameters

When user constant Cn-00 is set to 05, the system enters the motor parameter check mode.

Panel Display

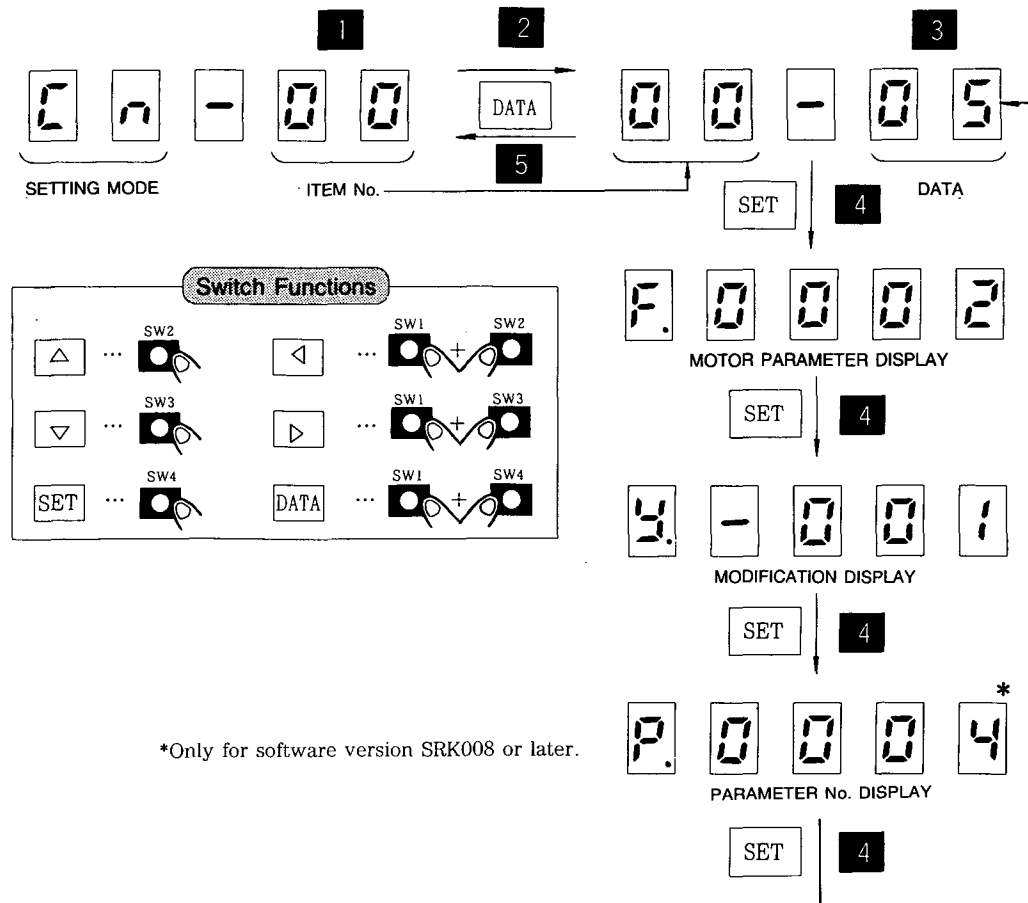

Fig. 8.15 Switch Functions in Motor Parameter Check

- 1 Set up item number 00 with  $\Delta$ ,  $\nabla$ ,  $\leftarrow$ , and  $\rightarrow$  keys.
- 2 With the [DATA] key, display the data related to the selected item number.
- 3 With the  $\Delta$ ,  $\nabla$ ,  $\leftarrow$ , and  $\rightarrow$  keys, select the number 05.
- 4 With the [SET] key, check the motor parameter.
- 5 With the [DATA] key, return to the item No. display status.
- 6 Using the [SET] key, switch from the setting mode to the monitor mode.



## (2) Parameter Display

### Motor Parameter

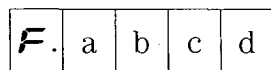

#### Motor Capacity (Hexadecimal display)

$$(C \times 16 + d) \times 100 \text{ [W]}$$

Nos. corresponding to Alphabets

A = 10

b = 11

C = 12

d = 13

E = 14

F = 15

#### Motor Type

0: M Series

1: F Series

2: S Series

4: D Series

5: G Series

#### Encoder Type

0: Incremental Encoder

1: Absolute Encoder

2: Incremental Encoder

3: Absolute Encoder

Motor Capacity Display

Capacity	Display			
200W	F.		0	2
300W	F.		0	3
500W	F.		0	5
700W	F.		0	7
900W	F.		0	9
1.0kW	F.		0	A
1.2kW	F.		0	C
1.5kW	F.		0	F
2.0kW	F.		1	4
3.0kW	F.		1	E
4.4kW	F.		2	C
6.0kW	F.		3	C

### Modification Index

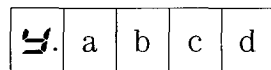

Modification No.

## 8.5 MONITOR MODE

In this mode, the speed reference, torque reference, and other data can be observed on the monitor panel.

Table 8.7 lists the data that can be monitored. The switch functions are indicated in Fig. 8.16.

Table 8.7 Data Monitored

Monitor No.	Data Monitored
00	Feedback Speed (r/min)
01	Speed Reference (r/min)
02	Torque Reference (%)
03	No. of Pulses from Phase-U edge (Phase-U)
04	Electrical Angle (1/10 deg)
05	Internal Status Bit Display (Refer to Table 8.4.)

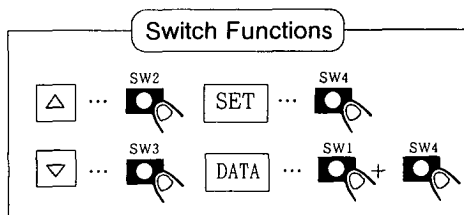
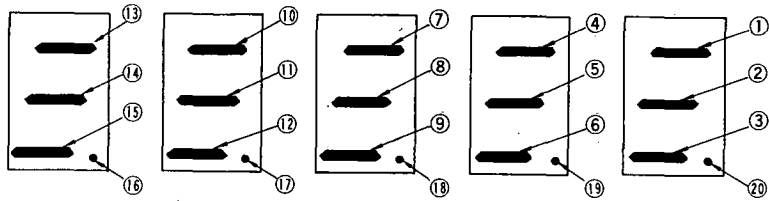

Fig. 8.16 Switch Functions in Monitor Mode

- 1 With the  and  keys, select a desired monitor No.
- 2 With the  key, initiate monitor display.
- 3 Using the  key, return to the monitor No. selection status.
- 4 With the  key, switch from the monitor mode to the fault traceback mode.



Bit. No.	Symbol	Contents
①	SVALM	Servo Alarm
②	DBON	Dynamic Brake ON
③	DIR	Reverse Rotation Mode
④	CLT	Current Limit
⑤	TGON	Motor Running
⑥	MSON	Mode Switch ON
⑦	ACON	AC Power Supply ON
⑧	SVRDY	Servo Ready
⑨	B-ON	Motor under Current Conduction
⑩	PA	Phase-A
⑪	PB	Phase-B
⑫	PC	Phase-C
⑬	PU	Phase-U
⑭	PV	Phase-V
⑮	PW	Phase-W
⑯	SVON	Servo ON
⑰	P-CON	PI Operation Input
⑱	P-OT	Forward Running Inhibit Input
⑲	N-OT	Reverse Running Inhibit Input

## 8.6 FAULT TRACEBACK MODE

In this mode, information on past fault occurrences can be displayed.

- Information on up to 10 past fault occurrences can be stored.
- When a fault is reset or the control power is turned ON, traceback data A.99 is saved (These data are also counted as one of a total of 10 stored items of fault information).
- For the relationship between traceback data and fault descriptions, refer to Table 8.9. The switch functions are indicated in Fig. 8.17.

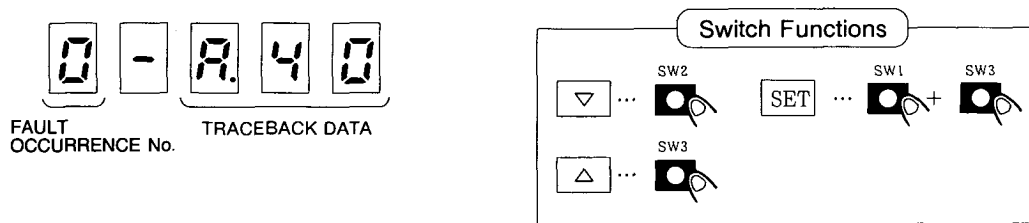

Fig. 8.17 Switch Functions in Fault Traceback Mode

- 1** With the  $\Delta$  and  $\nabla$  keys, increase or decrease the fault occurrence number. The fault information related to the selected number is then displayed. (The higher the fault occurrence number, the older the fault occurrence.)
- 2** With the  $\text{SET}$  key, switch from the fault traceback mode to the status display mode.

Table 8.9 Trouble Indications with Monitor Panel and Traceback Data

Monitor Panel Indication (Traceback Data)	Detection	Fault Output Code			ALM (1CN-38)	Remarks
		AL01	AL02	AL03		
		1CN-25	1CN-40	1CN-42		
R. 02	Parameter Breakdown	×	×	×	×	E <sup>2</sup> PROM Fault
R. 03	Main circuit detection error	×	×	×	×	
R. 04	Parameter setting error	×	×	×	×	
R. 10	Overcurrent	○	×	×	×	
R. 20	MCCB trip	×	○	×	×	
R. 30	Regeneration error	○	○	×	×	
R. 40	Overvoltage	×	×	○	×	
R. 51	Feedback overspeed	○	×	○	×	
R. 60	Undervoltage	×	○	○	×	
R. 71	Overload (high load)	○	○	○	×	
R. 72	Overload (low load)	○	○	○	×	
R. b1	Reference input read error	×	×	×	×	A/D Error
R. b2	External current limit read error	×	×	×	×	A/D Error
R. C1	Overrun (wrong wiring of motor circuit PG signal line)	○	×	○	×	Overrun Prevention
R. C2	Phase detection error (wrong wiring or disconnection of PG signal line: PU, PV, PW)	○	×	○	×	
R. C3	A, B-phase disconnection of PG signal line	○	×	○	×	Overrun Prevention
R. C4	C-phase disconnection of PG signal line	○	×	○	×	Overrun Prevention
R. F1	Open phase of power supply	×	○	×	×	Detected only when main power is started up.
R. F2	Power supply rise error	×	○	×	×	
—	CPU error	×	×	×	×	No alarm display
R. 99	Not applicable to alarm. (Only for traceback data) Alarm reset, power ON.					

Note: ○: Output transistor ON  
 ×: Output transistor OFF

## 9. INSTALLATION AND WIRING

### 9.1 RECEIVING

This motor has been put through stringent tests at the factory before shipment. After unpacking, however, check for the following.

- Nameplate ratings meet your requirements.
- It has sustained no damage during transportation.
- The output shaft should be hand-rotated freely. However, motors with holding brake do not rotate.
- Fastening bolts and screws are not loose.

If any part of the motor is damaged or lost, immediately contact your YASKAWA representative giving full details and nameplate data. If MCCB on the SERVOPACK is OFF, turn it ON. (For MCCB location, refer to Par. 11.1.2.)

### 9.2 INSTALLATION

#### 9.2.1 AC SERVOMOTOR

AC SERVOMOTOR can be installed either horizontally or vertically.

(1) Before mounting

Remove anticorrosive paint on shaft extension and flange surface with thinner before connecting the motor to the driven machine. See Fig. 9.1. Do not subject other parts of the motor to thinner.

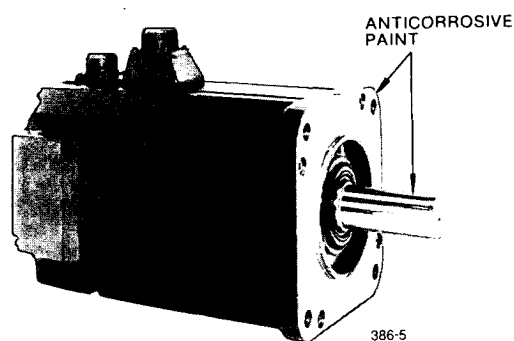

Fig. 9.1 Anticorrosive Paint to be Removed

## (2) Location

Use the motor under the following conditions.

- Indoors
- Free from corrosive and/or explosive gases or liquids
- Ambient temperature: 0 to +40°C
- Accessible for inspection and cleaning

If the AC SERVOMOTOR is subject to excessive water or oil droplets or mist, protect the motor with a cover. The motor can withstand a small amount of splashed water or oil (except for S series).

It is recommended that the motor be mounted with its connector placed down.

## (3) Environmental conditions

Ambient Temperature: 0 to +40°C

Storage Temperature: -20 to +60°C

Humidity: 20% to 80% RH (non-condensing)

## (4) Load coupling

True alignment of motor and driven machine is essential to prevent vibration, reduced bearing wear and coupling life, or shaft and bearing failures.

Use flexible couplings for direct drives. Alignment should be made in accordance with Fig. 9.2.

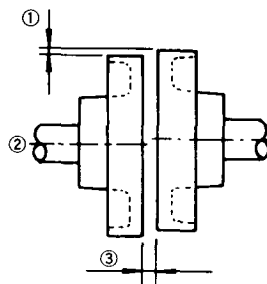

- ① Measure the gap between a straightedge and coupling halves at four equidistant points of the coupling. Each reading should not exceed 0.03 mm (0.0012 in.).
- ② Align the shafts.
- ③ Measure the gap between the coupling faces at four equidistant points around the coupling rim with a thickness gage. The maximum variation between any two readings should not exceed 0.03 mm (0.0012 in.).

Fig. 9.2 Alignment of Coupling

## (5) Allowable bearing load

Avoid shock to the motor shaft when mounting gear box, coupling or pulley. Don't exceed thrust and radial loads specified in Tables 4.1 to 4.5.

## 9.2.2 SERVOPACK

### (1) Installation

The SERVOPACK type CACR-SR□□BE is mounted on the base as standard.

### (2) Location

- When installed in a panel:  
Keep the temperature around Servopack at 55°C or below. (Fig. 9.3)
- When installed near a heat source:  
Keep the temperature around Servopack below 55°C. (Fig. 9.4)
- If subjected to vibration:  
Mount the unit on shock absorbing material.
- If corrosive gases are present:  
Avoid locations where corrosive gases exist as it may cause extensive damage over long use. Contactors and relays are especially vulnerable.
- Unfavorable atmospheric conditions:  
Select a location with minimum exposure to oil, water, hot air, high humidity, excessive dust or metallic particles.

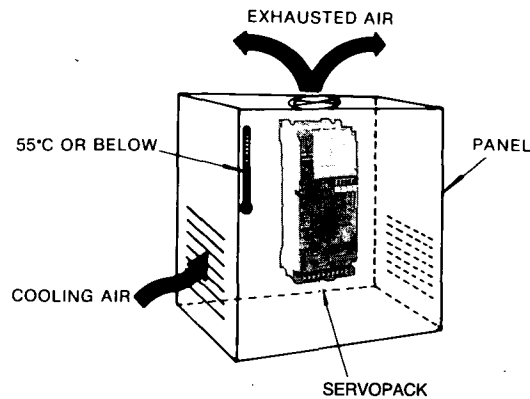

Fig. 9.3 Typical Layout for Panel Mounting

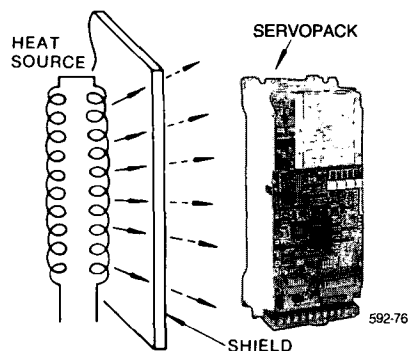

Fig. 9.4 Protection Against Heat Radiation



### (3) Mounting Direction

Mount the unit vertically on the wall using the mounting holes (4) on the base plate, with main terminals at the bottom. (Fig. 9.5)

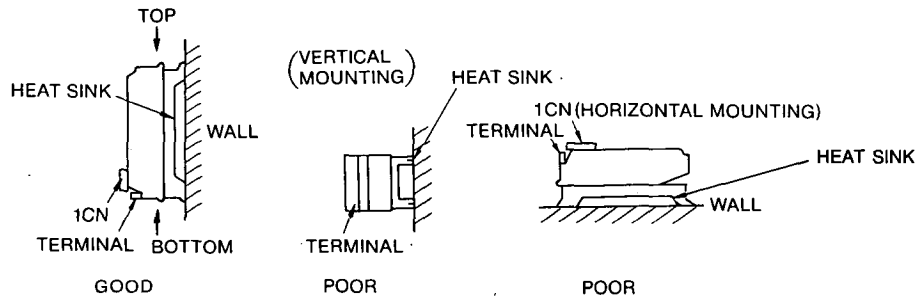

Fig. 9.5 Mounting Direction

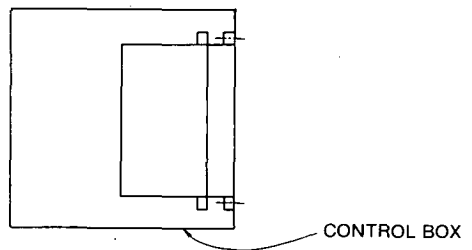

Fig. 9.6 Method of Usual Mounting

(4) Precautions

- Mounting Pitch

Standard mounting pitch is 150mm (5.91 in). If panel inside circulation is sufficient, such as when housed into the panel, 145mm (5.71 in) is also available.

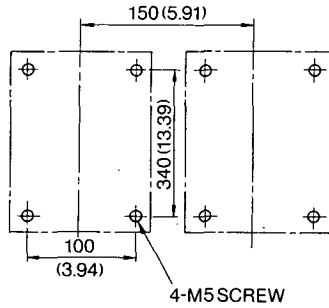
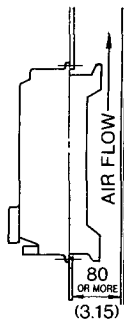

Fig. 9.7 Mounting Pitch

- Duct Ventilation

When heat sink section of SERVOPACK is installed on the panel exterior or in the duct, refer to Fig. 9.8. For type CACR-SR60BE1□M, duct ventilation mounting is not allowed.



Mounting of Duct Ventilation Type

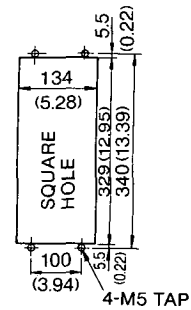

Panel Punching size

Fig. 9.8 Mounting

Note: When airtightness is required at duct ventilation, packing should be attached to SERVOPACK mounting part. Designate the SERVOPACK type with suffix -P, such as CACR-SR05BE12F-P.

## 9.3 WIRING

### 9.3.1 Rated Current and Cable Size

Tables 9.1 and 9.2 show external terminals, rated current, and cable sizes of the power unit and SERVOPACK, respectively. Select the type and size of cables to meet ambient conditions and current capacity. The cable size is calculated so that a bundle of three cables can carry the rated current at an ambient temperature of 40°C. Table 9.3 lists the type of cables.

Table 9.1 Rated Current (A: rms)

External Terminal		Type CACR- Symbol	Rated Current A (Effective Current)										
			SR02BE	SR03BE	SR05BE	SR07BE	SR10BE	SR15BE	SR20BE	SR30BE	SRT44BE	SR60BE	
On Line	Main Circuit Power Input	R, S, T	2	2	5	6	8	10	12	18	24	32	
	Motor Connection	U, V, W	3.0	3.0	4.2	5.8	7.6	11.7	18.8	26.0	33.0	45	
	Control Power Input	r, t	0.5										
	Regenerative* Resistance Connection	Y <sub>3</sub> , Y <sub>4</sub>	15A							30A		50A	
	Fan Connection (Only for type SR60BE)	F <sub>1</sub> , F <sub>3</sub>	—										
Off Line	Control I/O Signal Connector	1CN	100mA DC max										
	PG Signal Connector	2CN	100mA DC max (500mA DC for power line only)										
	Ground		—										

\*Maximum current when external regenerative resistance is connected.

Table 9.2 Recommended Cable Size of SERVOPACK

External Terminal		Type CACR- Symbol	Cable Size										
			SR02BE	SR03BE	SR05BE	SR07BE	SR10BE	SR15BE	SR20BE	SR30BE	SRT44BE	SR60BE	
On Line	Main Circuit Power Input	R, S, T	HIV 1.25 or more			HIV 2.0 or more		HIV 3.5 or more			HIV 5.5 or more		HIV 8 or more
	Motor Connection	U, V, W	HIV 1.25 or more			HIV 2.0 or more	HIV 3.5 or more				HIV 5.5 or more		HIV 8 or more
	Control Power Input	r, t	HIV 1.25 or more										
	Regenerative* Resistance Connection	Y <sub>3</sub> , Y <sub>4</sub>	HIV 1.25 or more										
	Fan Connection (Only for type SR60BE)	F <sub>1</sub> , F <sub>3</sub>	—										
Off Line	Control I/O Signal Connector	1CN	<ul style="list-style-type: none"> <li>• Two-core twisted shielded cable</li> <li>• Core must be 0.2 mm<sup>2</sup> or more</li> <li>• Tin-plated soft-copper twisted cable</li> <li>• Finished cable dimension: 16 dia or less for 1CN 11 dia or less for 2CN</li> </ul>										
	PG Signal Connector	2CN											
	Ground		HIV 2.0 or more										

- Notes:
1. For main circuits, use cables of 600 V or more.
  2. Where cables are bundled or run through a duct (unplasticized polyvinyl chloride conduit or metallic conduit), select the larger cable size than listed considering the current drop rate of the cables.
  3. Where the ambient (panel inside) temperature is high (40°C to 60°C), use heat-resistant cables.
  4. Tightening torque: 13 to 16 kg•cm (1.28 to 1.57 N•m)

Table 9.3 Cable Specifications

Type of Lead	Allowable Conductor Temperature (°C)
Vinyl Cable (PVC)	—
600 V Vinyl Cable (IV)	60
Special Heat-Resistant Cable (HIV)	75

Notes:

1. For main circuits, use cables of 600 V or more.
2. Where cables are bundled or run in a duct (unplasticized polyvinyl chloride conduit or metallic conduit), select a cable size larger than listed considering the current drop rate of the cables.
3. Where the ambient (panel interior) temperature is high (40°C to 60°C), use heat-resistant cables.

### 9.3.2 Wiring Precautions

SERVOPACK is a device for speed control of 3000:1, and signal level of several milli-volts or less. The following precautions should be taken when wiring.

(1) For signal lines and PG feedback lines, use twisted cables or multi-core shielded twisted-pair cables (YASKAWA Drawing No. DP9400064 or DE8400093).

Cable length is a maximum of 3 m for reference input lines and a maximum of 20 m for PG feedback lines. Use the shortest possible length.

(2) For ground line, cable should be as heavy as possible to provide class 3 ground (ground resistance 100 Ω or less). Use central grounding point. If the motor and machine are insulated, ground the motor.

(3) To prevent malfunction due to noise, take the following precautions:

- Place noise filters, SERVOPACK and I/O reference as near as possible to each other.
- Make sure to insert a surge suppressing circuit into the relay, electromagnetic contact, and solenoid coils.
- Run the power line and signal line, keeping the distance to 30 cm or more; do not run them in the same duct or in a bundle.
- When the same power is used for SERVOPACK, as for an electric welder or electric welder or electrical discharge machine or when a high-frequency noise source is present in the vicinity, use filters in the power and input circuits.
- SERVOPACK uses a switching amplifier, and electrical noise may be present in the signal line. Never leave the termination of the analog input wiring open.

(4) Remedy for Radio Frequency Interference (R.F.I)

SERVOPACK may interfere with radio reception. If the controller interferes with radio reception, connect a noise filter to power supply.

(5) The signal line uses cables whose core is extremely fine (0.2 to 0.3 mm<sup>2</sup>). Avoid using excessive force which may damage these cables.

### 9.3.3 Power Loss

The power loss of SERVOPACK is shown in Table 9.4.

Table 9.4 Power Loss at Rated Output

SERVOPACK Type CACR-	Output Current A	Power Loss			
		Main Circuit W	Regenerative Resistance W	Control Circuit W	Total W
SR02BE	3.0	20	10	60	90
SR03BE	3.0	20			90
SR05BE	4.2	40			110
SR07BE	5.8	60	20		140
SR10BE	7.6	70			150
SR15BE	11.7	80			160
SR20BE	18.8	100	40		200
SR30BE	26.0	160	80		300
SR40BE	33.0	210	100		370
SR60BE	45.0	300	120		480

Note: The regenerative resistor causes power loss when the motor is decelerated, but is negligible if the motor is not started and stopped frequently.

# 10. DIMENSIONS in mm (inches)

## 10.1 SERVOMOTOR

### 10.1.1 M Series

#### (1) Standard Type

- Types USAMED-03□□1, -06□□1 (Taper Shaft), -09B□□2 (Straight Shaft)

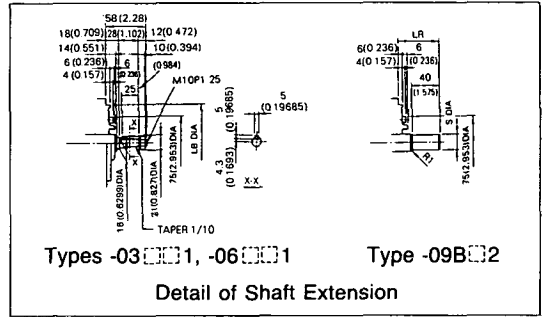
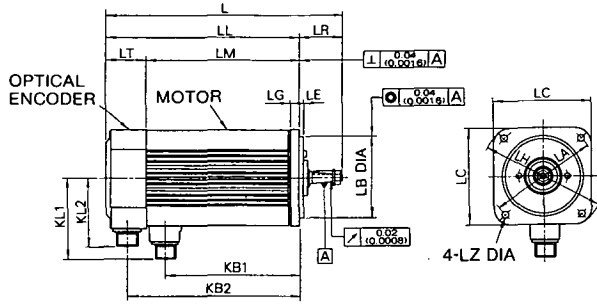

- Types USAMED-12B□□2, -20B□□2, -30B□□2, -44B□□2 (Straight Shaft)

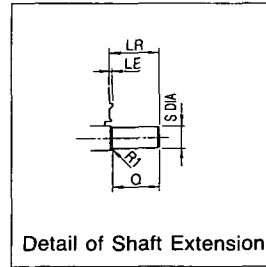
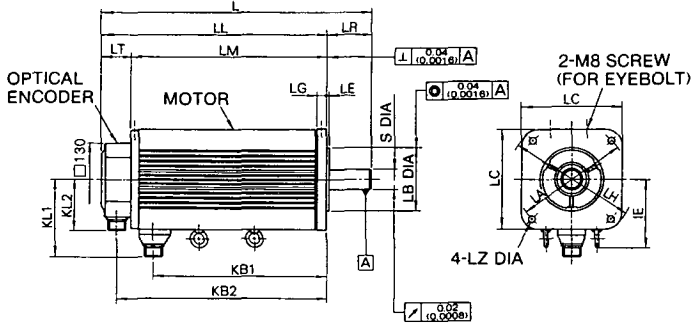

- Type USAMKD-60B□□2 (Straight Shaft)

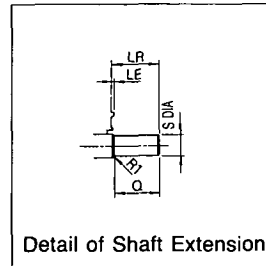
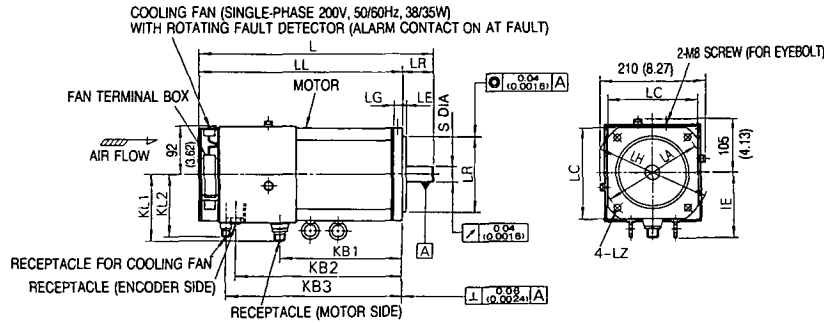

AC SERVO MOTOR Type USAMED-	L	LL	LM	LR	LT	KB1	KB2	KB3	IE	KL1	KL2	Flange Surface						Shaft Extension		Approx Mass kg (lb)			
												LA	LB	LC	LE	LG	LH	LZ	S		Q		
03□□1*	263 (10.34)	205 (8.06)	150 (5.9)	58 (2.28)	55 (2.16)	127 (5.0)	177 (6.97)	—	—	109 (4.29)	92 (3.62)	145 (5.71)	110 (4.3307)	130 (5.12)	6 (0.24)	12 (0.47)	165 (6.5)	9 (0.35)	—	—	—	—	8.5 (18.7)
06□□1*	320 (12.59)	262 (10.31)	207 (8.15)	58 (2.28)	55 (2.16)	184 (7.24)	234 (9.21)	—	—	109 (4.29)	92 (3.62)	145 (5.71)	110 (4.3307)	130 (5.12)	6 (0.24)	12 (0.47)	165 (6.5)	9 (0.35)	—	—	—	—	13 (28.7)
09B□□2*	389 (15.31)	331 (13.03)	276 (10.87)	58 (2.28)	55 (2.16)	253 (9.96)	303 (11.93)	—	—	109 (4.29)	92 (3.62)	145 (5.71)	110 (4.3307)	130 (5.12)	6 (0.24)	12 (0.47)	165 (6.5)	9 (0.35)	22 (0.8661)	40 (1.575)	40 (1.575)	76 (2.992)	20 (44.1)
12B□□2*	344 (13.54)	265 (10.43)	211 (8.30)	79 (3.11)	54 (2.13)	172 (6.77)	237 (9.33)	—	—	139 (5.47)	92 (3.62)	200 (7.87)	114.3 (4.5)	180 (7.08)	3.2 (0.13)	18 (0.71)	230 (9.1)	13.5 (0.53)	35 (1.3779)	76 (2.992)	76 (2.992)	76 (2.992)	22 (48.5)
20B□□2	401 (15.79)	322 (12.69)	268 (10.55)	79 (3.11)	54 (2.13)	229 (9.01)	294 (11.57)	—	123 (4.84)	139 (5.47)	92 (3.62)	200 (7.87)	114.3 (4.5)	180 (7.08)	3.2 (0.13)	18 (0.71)	230 (9.1)	13.5 (0.53)	35 (1.3779)	76 (2.992)	76 (2.992)	76 (2.992)	29 (63.9)
30B□□2	486 (19.13)	407 (16.02)	353 (13.90)	79 (3.11)	54 (2.13)	314 (12.36)	379 (14.92)	—	123 (4.84)	139 (5.47)	92 (3.62)	200 (7.87)	114.3 (4.5)	180 (7.08)	3.2 (0.13)	18 (0.71)	230 (9.1)	13.5 (0.53)	35 (1.3779)	76 (2.992)	76 (2.992)	76 (2.992)	41 (90.4)
44B□□2	688 (27.09)	578 (22.76)	524 (20.63)	110 (4.33)	53 (2.13)	476 (18.74)	550 (21.65)	—	123 (4.84)	149 (5.87)	92 (3.62)	200 (7.87)	114.3 (4.5)	180 (7.08)	3.2 (0.13)	18 (0.71)	230 (9.1)	13.5 (0.53)	42 (1.6535)	110 (4.33)	110 (4.33)	110 (4.33)	66 (145.5)
USAMKD-60B□□2	775 (30.51)	665 (26.18)	—	110 (4.33)	—	476 (18.74)	550 (21.65)	575 (22.64)	123 (4.84)	149 (5.87)	125 (4.92)	200 (7.87)	114.3 (4.5)	180 (7.08)	3.2 (0.13)	18 (0.71)	230 (9.1)	13.5 (0.53)	42 (1.6535)	110 (4.33)	110 (4.33)	110 (4.33)	75 (165.3)

\* Not Provided with an eyebolt.

- Notes: 1. The blank □ of motor type depends on class of detectors.  
 Standard : 2 (8192 P/R)  
 Semi-standard: 3 (2048 P/R)  
 2. Vibration: 15 μm or below.

3. Plug and clamp are not attached for receptacle connection.  
 4. Connector specifications: Refer to Table 3.6.  
 5. It is recommended that the motor be mounted with its connector placed down.

## (2) With Brake

- Types USAMED-03□□10E, -06□□10E (Taper Shaft), -09B□20E (Straight Shaft)

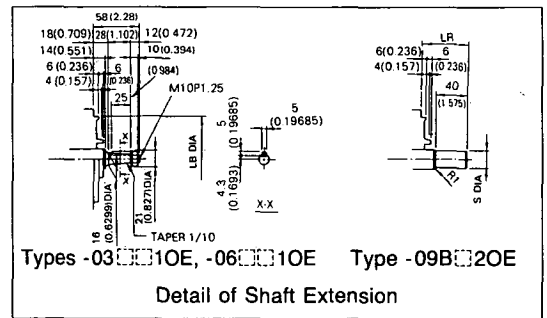
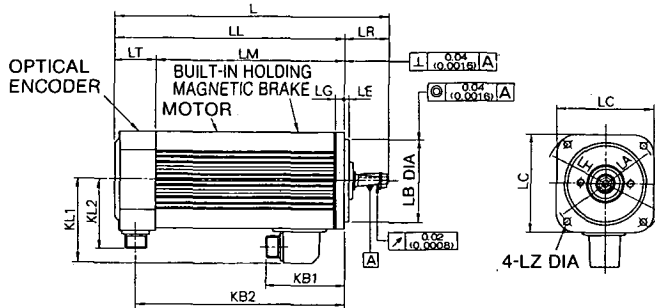

- Types USAMED -12B□20E, -20B□20E, -30B□20E (Straight Shaft)

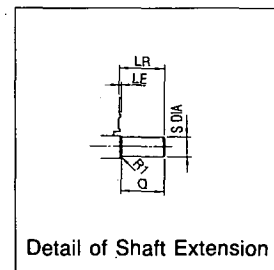
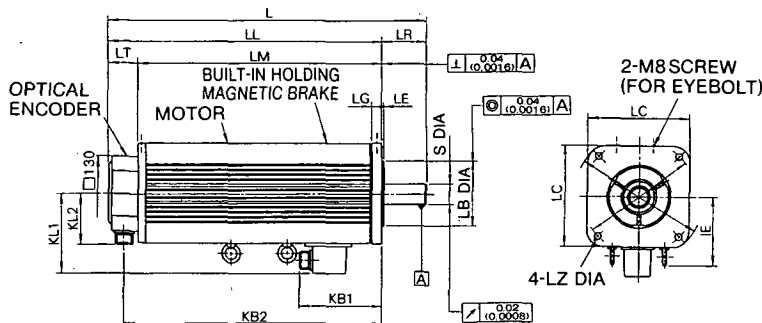

AC SERVOMOTOR Type USAMED-	L	LL	LM	LR	LT	KB1	KB2	IE	KL1	KL2	Flange Surface						Shaft Extension		Approx Mass kg (lb)	BRAKE		
											LA	LB	LC	LE	LG	LH	LZ	S		Q	BRAKING TORQUE N·m (lb-in)	INERTIA (GD <sup>2</sup> /4) kg·m <sup>2</sup> (lb-in <sup>2</sup> )
03□□10E*	320 (12.60)	262 (10.31)	207 (8.15)	58 (2.28)	55 (2.16)	128 (5.04)	234 (9.21)	—	113 (4.45)	92 (3.62)	145 (5.71)	110 (4.3307)	130 (5.12)	6 (0.24)	12 (0.47)	165 (6.5)	9 (0.35)	—	—	11.5 (25.4)	5.88 (52.1)	0.85 × 10 <sup>-4</sup> (0.752 × 10 <sup>-3</sup> )
06□□10E*	366 (14.41)	308 (12.13)	253 (9.97)	58 (2.28)	55 (2.16)	118 (4.65)	280 (11.02)	—	113 (4.45)	92 (3.62)	145 (5.71)	110 (4.3307)	130 (5.12)	6 (0.24)	12 (0.47)	165 (6.5)	9 (0.35)	—	—	15 (33.1)	—	—
09B□20E*	436 (17.17)	378 (14.89)	323 (12.73)	58 (2.28)	55 (2.16)	108 (4.25)	350 (13.78)	—	113 (4.45)	92 (3.62)	145 (5.71)	110 (4.3307)	130 (5.12)	6 (0.24)	12 (0.47)	165 (6.5)	9 (0.35)	22 (0.8661)	40 (1.575)	23 (50.7)	8.83 (78.1)	0.9 × 10 <sup>-4</sup> (0.797 × 10 <sup>-3</sup> )
12B□20E*	422 (16.61)	343 (13.5)	289 (11.38)	79 (3.11)	54 (2.13)	164 (6.46)	315 (12.4)	123 (4.84)	143 (5.63)	92 (3.62)	200 (7.87)	114.3 (4.5)	180 (7.08)	3.2 (0.13)	18 (0.71)	230 (9.1)	13.5 (0.53)	35 (1.3779)	76 (2.992)	30 (66.2)	—	—
20B□20E	486 (19.13)	407 (16.02)	353 (13.90)	79 (3.11)	54 (2.13)	164 (6.46)	379 (14.92)	123 (4.84)	143 (5.63)	92 (3.62)	200 (7.87)	114.3 (4.5)	180 (7.08)	3.2 (0.13)	18 (0.71)	230 (9.1)	13.5 (0.53)	35 (1.3779)	76 (2.992)	37 (81.6)	35.3 (312.5)	6.25 × 10 <sup>-4</sup> (5.53 × 10 <sup>-3</sup> )
30B□20E	567 (22.32)	488 (19.21)	434 (17.09)	79 (3.11)	54 (2.13)	164 (6.46)	460 (18.11)	123 (4.84)	143 (5.63)	92 (3.62)	200 (7.87)	114.3 (4.5)	180 (7.08)	3.2 (0.13)	18 (0.71)	230 (9.1)	13.5 (0.53)	35 (1.3779)	76 (2.992)	49 (108)	—	—

\* Not provided with an eyebolt.

Notes: 1. The blank □ of motor type depends on class of detectors.

Standard : 2 (8192 P/R)

Semi-standard: 3 (2048 P/R)

2. Vibration: 15 μm or below.

3. Plug and clamp are not attached for receptacle connection.

4. Connector specifications: Refer to Table 3.6.

5. It is recommended that the motor be mounted with its connector placed down.

6. Power supply for brake is 90VDC.

7. Type USAMED-44B□20B is for 4.4kW. Contact your YASKAWA representative.

## (3) Shaft Extension of Straight Shaft with Keyway

Both SERVOMOTOR with brake and without brake have the same dimensions except for shaft extension. Shaft extensions are shown below:

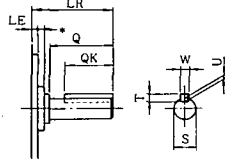

\* 6 mm (0.236 in.) for USAMED-03□□2 to 09B□□2.

Motor Type		LR	LE	Dimensions of Shaft Extension						
Without Brake	With Brake			S	Q	QK	T	U	W	
*USAMED-03□□2K	*USAMED-03□□2KE	58 (2.28)	6 (0.24)	19 (0.7480)	40 (1.57)	25 (0.98)	5 (0.19685)	3 (0.1181)	5 (0.19685)	
*USAMED-06□□2K	*USAMED-06□□2KE	58 (2.28)	6 (0.24)	19 (0.7480)	40 (1.57)	25 (0.98)	5 (0.19685)	3 (0.1181)	5 (0.19685)	
*USAMED-09B□2K	*USAMED-09B□2KE	58 (2.28)	6 (0.24)	19 (0.7480)	40 (1.57)	25 (0.98)	6 (0.2362)	3.5 (0.1378)	6 (0.2362)	
USAMED-12B□2K	USAMED-12B□2KE	79 (3.11)	3.2 (0.13)	35 (1.3379)	76 (2.99)	60 (2.36)	8 (0.315)	5 (0.19685)	10 (0.3937)	
USAMED-20B□2K	USAMED-20B□2KE	79 (3.11)	3.2 (0.13)	35 (1.3379)	76 (2.99)	60 (2.36)	8 (0.315)	5 (0.19685)	10 (0.3937)	
USAMED-30B□2K	USAMED-30B□2KE	79 (3.11)	3.2 (0.13)	35 (1.3379)	76 (2.99)	60 (2.36)	8 (0.315)	5 (0.19685)	10 (0.3937)	
USAMED-44B□2K	USAMED-44B□2KB	110 (4.33)	3.2 (0.13)	42 (1.6535)	110 (4.33)	90 (3.54)	8 (0.315)	5 (0.19685)	12 (0.3937)	

# 10.1.2 F Series

## (1) Standard Type

- Types USAFED-02□□□1, -03□□□1 (Taper Shaft)

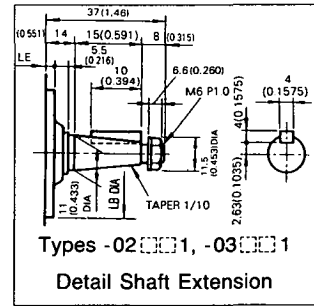
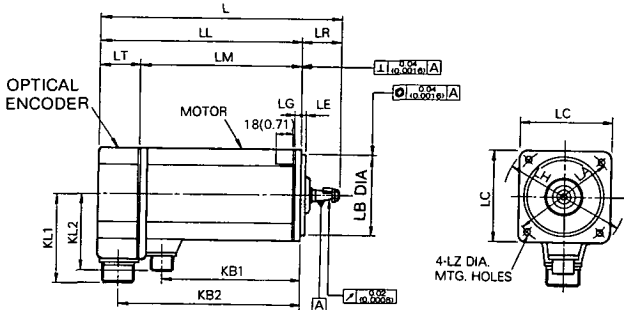

- Types USAFED-05□□□1, -09□□□1 (Taper Shaft), -13C□□2 (Straight Shaft)

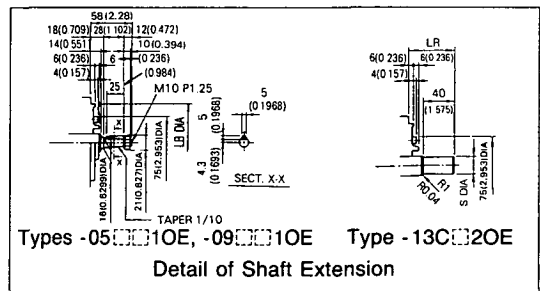
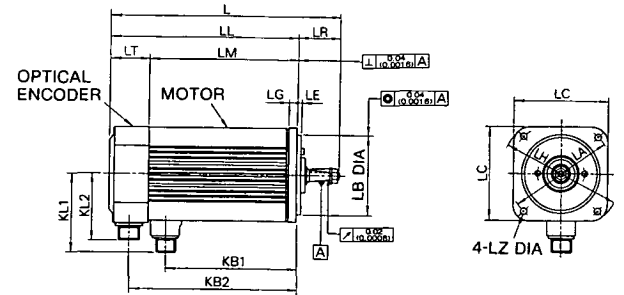

- Types USAFED-20C□□2, -30C□□2, -44C□□2 (Straight Shaft)

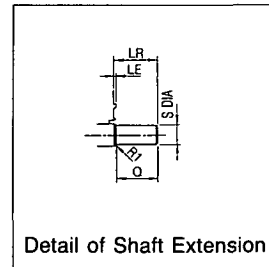
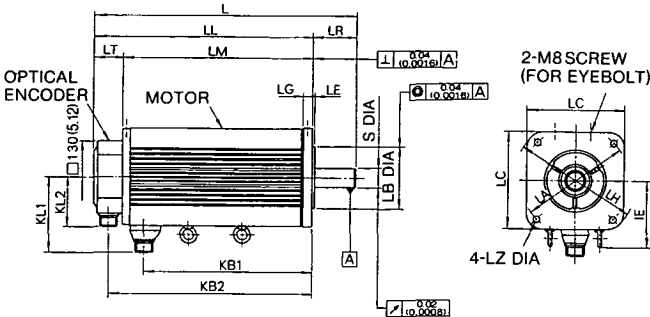

AC SERVO MOTOR Type USAFED-	L	LL	LM	LR	LT	KB1	KB2	IE	KL1	KL2	Flange Surface						Shaft Extension		Approx Mass kg (lb)	
											LA	LB	LC	LE	LG	LH	LZ	S		Q
02□□□1*	190 (7.48)	153 (6.02)	113 (4.45)	37 (1.46)	40 (1.57)	90 (3.54)	132 (5.19)	—	76 (3.03)	87 (3.43)	100 (3.94)	80 <sup>0</sup> <sub>(-0.030)</sub> (3.1496 <sup>0</sup> <sub>(-0.0012)</sub> )	90 (3.54)	4 (0.157)	7 (0.276)	120 (4.72)	6.6 (0.26)	—	—	4 (8.8)
03□□□1*	236 (9.29)	199 (7.83)	159 (6.26)	37 (1.46)	40 (1.57)	136 (5.35)	178 (7.0)	—	76 (3.03)	87 (3.43)	100 (3.94)	80 <sup>0</sup> <sub>(-0.030)</sub> (3.1496 <sup>0</sup> <sub>(-0.0012)</sub> )	90 (3.54)	4 (0.157)	7 (0.276)	120 (4.72)	6.6 (0.26)	—	—	6 (13.2)
05□□□1*	263 (10.35)	205 (8.07)	150 (5.91)	58 (2.28)	55 (2.16)	127 (5.0)	177 (6.97)	—	109 (4.29)	92 (3.62)	145 (5.71)	110 <sup>0</sup> <sub>(-0.035)</sub> (4.3307 <sup>0</sup> <sub>(-0.0014)</sub> )	130 (5.12)	6 (0.24)	12 (0.47)	165 (6.5)	9 (0.35)	—	—	8.5 (18.7)
09□□□1*	320 (12.6)	262 (10.32)	207 (8.16)	58 (2.28)	55 (2.16)	184 (7.24)	234 (9.21)	—	109 (4.29)	92 (3.62)	145 (5.71)	110 <sup>0</sup> <sub>(-0.035)</sub> (4.3307 <sup>0</sup> <sub>(-0.0014)</sub> )	130 (5.12)	6 (0.24)	12 (0.47)	165 (6.5)	9 (0.35)	—	—	13 (28.7)
13C□□2*	389 (15.31)	331 (13.03)	276 (10.87)	58 (2.28)	55 (2.16)	253 (9.96)	303 (11.93)	—	109 (4.29)	92 (3.62)	145 (5.71)	110 <sup>0</sup> <sub>(-0.035)</sub> (4.3307 <sup>0</sup> <sub>(-0.0014)</sub> )	130 (5.12)	6 (0.24)	12 (0.47)	165 (6.5)	9 (0.35)	22 <sup>0</sup> <sub>(-0.013)</sub> (0.8661 <sup>0</sup> <sub>(-0.0005)</sub> )	40 <sup>0</sup> <sub>(-0.013)</sub> (1.57)	20 (44.1)
20C□□2*	344 (13.54)	265 (10.43)	211 (8.3)	79 (3.11)	54 (2.13)	172 (6.77)	237 (9.33)	—	139 (5.47)	92 (3.62)	200 (7.88)	114.3 <sup>0</sup> <sub>(-0.025)</sub> (4.5 <sup>0</sup> <sub>(-0.001)</sub> )	180 (7.09)	3.2 (0.13)	18 (0.71)	230 (9.06)	13.5 (0.53)	35 <sup>0</sup> <sub>(-0.01)</sub> (1.3379 <sup>0</sup> <sub>(-0.0004)</sub> )	76 <sup>0</sup> <sub>(-0.01)</sub> (2.99)	22 (48.5)
30C□□2	401 (15.79)	322 (12.68)	268 (10.55)	79 (3.11)	54 (2.13)	229 (9.02)	294 (11.57)	123 (4.85)	139 (5.47)	92 (3.62)	200 (7.88)	114.3 <sup>0</sup> <sub>(-0.025)</sub> (4.5 <sup>0</sup> <sub>(-0.001)</sub> )	180 (7.09)	3.2 (0.13)	18 (0.71)	230 (9.06)	13.5 (0.53)	35 <sup>0</sup> <sub>(-0.01)</sub> (1.3379 <sup>0</sup> <sub>(-0.0004)</sub> )	76 <sup>0</sup> <sub>(-0.01)</sub> (2.99)	29 (63.9)
44C□□2	486 (19.14)	407 (16.02)	353 (13.90)	79 (3.11)	54 (2.13)	314 (12.36)	379 (14.92)	123 (4.85)	139 (5.47)	92 (3.62)	200 (7.88)	114.3 <sup>0</sup> <sub>(-0.025)</sub> (4.5 <sup>0</sup> <sub>(-0.001)</sub> )	180 (7.09)	3.2 (0.13)	18 (0.71)	230 (9.06)	13.5 (0.53)	35 <sup>0</sup> <sub>(-0.01)</sub> (1.3379 <sup>0</sup> <sub>(-0.0004)</sub> )	76 <sup>0</sup> <sub>(-0.01)</sub> (2.99)	41 (90.4)

- \* Not Provided with an eyebolt.  
 Notes: 1. The blank □ of motor type depends on class of detectors.  
 Standard : 2 (8192 P/R)  
 Semi-standard: 3 (2048 P/R)  
 2. Vibration: 15 μm or below.  
 3. Plug and clamp are not attached for receptacle connection.  
 4. Connector specifications: Refer to Table 3.7.  
 5. It is recommended that the motor be mounted with its connector placed down.  
 6. Power supply for brake is 90VDC.



## (2) With Brake

- Types USAFED-02□□10E, -03□□10E (Taper Shaft)

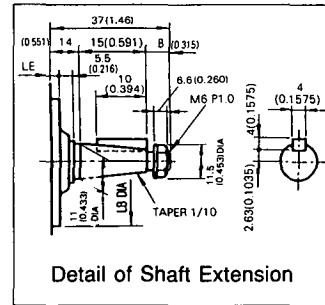
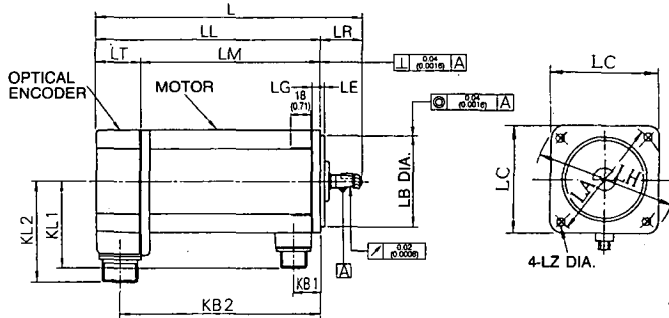

- Types USAFED-05□□10E, -09□□10E (Taper Shaft), -13C□20E (Straight Shaft)

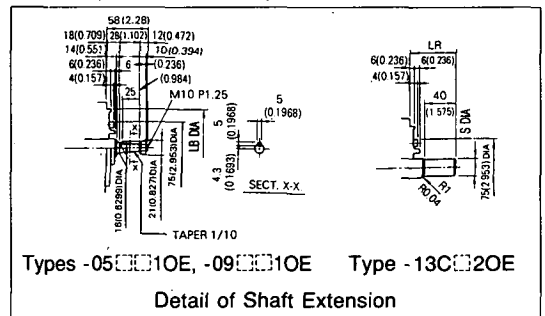
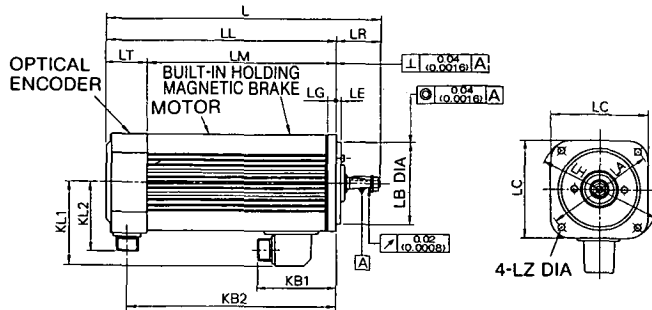

- Types USAFED-20C□20E, -30C□20E, -44C□20E (Straight Shaft)

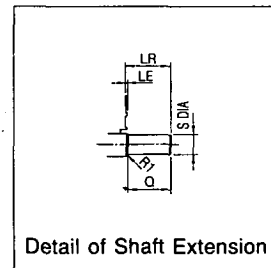
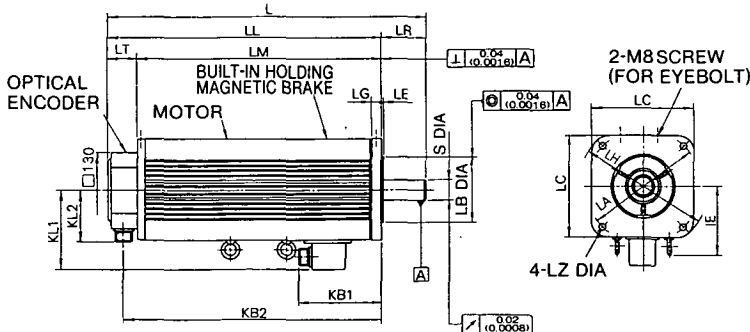

AC SERVO MOTOR Type USAFED-	L	LL	LM	LR	LT	KB1	KB2	IE	KL1	KL2	Flange Surface						Shaft Extension		Approx Mass kg (lb)	BRAKE		
											LA	LB	LC	LE	LG	LH	LZ	S		Q	BRAKING TORQUE N·m (lb-in)	INERTIA (GD <sup>2</sup> /4) kg·m <sup>2</sup> (lb-in <sup>2</sup> )
02□□10E*	236 (9.29)	199 (7.83)	159 (6.26)	37 (1.46)	40 (1.57)	24 (0.95)	178 (7.0)	-	76 (3.43)	87 (3.43)	100 (3.94)	80 (3.1496)	90 (3.54)	4 (0.157)	7 (0.276)	120 (4.72)	6.6 (0.26)	-	-	5 (11.0)	0.98 (8.67)	0.075 × 10 <sup>-4</sup> (0.066 × 10 <sup>-4</sup> )
03□□10E*	286 (11.26)	249 (9.8)	209 (8.23)	37 (1.46)	40 (1.57)	24 (0.95)	228 (8.98)	-	76 (3.43)	87 (3.43)	100 (3.94)	80 (3.1496)	90 (3.54)	4 (0.157)	7 (0.276)	120 (4.72)	6.6 (0.26)	-	-	7 (15.4)	1.96 (13.0)	0.113 × 10 <sup>-4</sup> (0.1 × 10 <sup>-4</sup> )
05□□10E*	320 (12.60)	262 (10.31)	207 (8.15)	58 (2.28)	55 (2.16)	128 (5.04)	234 (9.21)	-	113 (4.45)	92 (3.62)	145 (5.71)	110 (4.3307)	130 (5.12)	6 (0.24)	12 (0.47)	165 (6.5)	9 (0.35)	-	-	11.5 (25.4)	5.88 (52.1)	0.85 × 10 <sup>-4</sup> (0.752 × 10 <sup>-4</sup> )
09□□10E*	366 (14.41)	308 (12.13)	253 (9.97)	58 (2.28)	55 (2.16)	118 (4.65)	280 (11.02)	-	113 (4.45)	92 (3.62)	145 (5.71)	110 (4.3307)	130 (5.12)	6 (0.24)	12 (0.47)	165 (6.5)	9 (0.35)	-	-	15 (33.1)	-	-
13C□20E*	436 (17.17)	378 (14.89)	323 (12.73)	58 (2.28)	55 (2.16)	118 (4.65)	350 (13.78)	-	113 (4.45)	92 (3.62)	145 (5.71)	110 (4.3307)	130 (5.12)	6 (0.24)	12 (0.47)	165 (6.5)	9 (0.35)	22 (0.8661)	40 (1.57)	23 (50.7)	8.83 (78.1)	7.90 × 10 <sup>-4</sup> (0.797 × 10 <sup>-4</sup> )
20C□20E*	422 (16.61)	343 (13.50)	289 (11.38)	79 (3.11)	54 (2.13)	164 (6.46)	315 (12.4)	123 (4.85)	143 (5.63)	92 (3.62)	200 (7.88)	114.3 (4.5)	180 (7.09)	3.2 (0.13)	18 (0.71)	230 (9.06)	13.5 (0.53)	35 (1.3379)	76 (2.99)	30 (66.2)	-	-
30C□20E	486 (19.13)	407 (16.02)	353 (13.90)	79 (3.11)	54 (2.13)	164 (6.46)	379 (14.92)	123 (4.85)	143 (5.63)	92 (3.62)	200 (7.88)	114.3 (4.5)	180 (7.09)	3.2 (0.13)	18 (0.71)	230 (9.06)	13.5 (0.53)	35 (1.3379)	76 (2.99)	37 (81.6)	35.3 (312.5)	6.25 × 10 <sup>-4</sup> (5.53 × 10 <sup>-4</sup> )
44C□20E	567 (22.32)	488 (19.21)	434 (17.09)	79 (3.11)	54 (2.13)	164 (6.46)	460 (18.11)	123 (4.85)	143 (5.63)	92 (3.62)	200 (7.88)	114.3 (4.5)	180 (7.09)	3.2 (0.13)	18 (0.71)	230 (9.06)	13.5 (0.53)	35 (1.3379)	76 (2.99)	49 (108.1)	-	-

\* Not provided with an eyebolt.

Notes: 1. The blank □ of motor type depends on class of detectors.

Standard : 2 (8192 P/R)  
Semi-standard: 3 (2048 P/R)

2. Vibration: 15μm or below.

3. Plug and clamp are not attached for receptacle connection.

4. Connector specifications: Refer to Table 3.7.

5. It is recommended that the motor be mounted with its connector placed down.

6. Power supply for brake is 90VDC.

### (3) Shaft Extension of Straight Shaft with Keyway

Both SERVOMOTORS with brake and without brake have the same dimensions except for shaft extension. Shaft extensions are shown below:

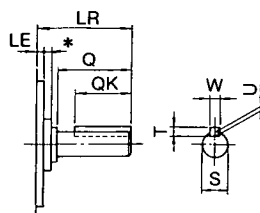

Motor Type		LR	LE	Dimensions of Shaft Extension						
Without Brake	With Brake			S	Q	QK	T	U	W	
*USAFED-02□□2K	*USAFED-02□□2KE	37 (1.46)	4 (0.157)	14 (0.5512)	$\begin{matrix} 0 \\ -0.011 \\ -0.0004 \end{matrix}$	25 (0.98)	15 (0.59)	5 (0.1968)	3 (0.1181)	5 (0.1968)
*USAFED-03□□2K	*USAFED-03□□2KE	37 (1.46)	4 (0.157)	14 (0.5512)	$\begin{matrix} 0 \\ -0.011 \\ -0.0004 \end{matrix}$	25 (0.98)	15 (0.59)	5 (0.1968)	3 (0.1181)	5 (0.1968)
*USAFED-05□□2K	*USAFED-05□□2KE	58 (2.28)	6 (0.24)	19 (0.7480)	$\begin{matrix} 0 \\ -0.013 \\ -0.0005 \end{matrix}$	40 (1.57)	25 (0.98)	5 (0.1968)	3 (0.1181)	5 (0.1968)
*USAFED-09□□2K	*USAFED-09□□2KE	58 (2.28)	6 (0.24)	19 (0.7480)	$\begin{matrix} 0 \\ -0.013 \\ -0.0005 \end{matrix}$	40 (1.57)	25 (0.98)	5 (0.1968)	3 (0.1181)	5 (0.1968)
*USAFED-13C□2K	*USAFED-13C□2KE	58 (2.28)	6 (0.24)	22 (0.8661)	$\begin{matrix} 0 \\ -0.013 \\ -0.0005 \end{matrix}$	40 (1.57)	25 (0.98)	6 (0.2362)	3.5 (0.1378)	6 (0.2362)
USAFED-20C□2K	USAFED-20C□2KE	79 (3.11)	3.2 (0.13)	35 (1.3379)	$\begin{matrix} -0.01 \\ 0 \\ -0.0004 \end{matrix}$	76 (2.99)	60 (2.36)	8 (2.2835)	5 (0.1968)	10 (0.3937)
USAFED-30C□2K	USAFED-30C□2KE	79 (3.11)	3.2 (0.13)	35 (1.3379)	$\begin{matrix} -0.01 \\ 0 \\ -0.0004 \end{matrix}$	76 (2.99)	60 (2.36)	8 (2.2835)	5 (0.1968)	10 (0.3937)
USAFED-44C□2K	USAFED-44C□2KE	79 (3.11)	3.2 (0.13)	35 (1.3379)	$\begin{matrix} -0.01 \\ 0 \\ -0.0004 \end{matrix}$	76 (2.99)	60 (2.36)	8 (2.2835)	5 (0.1968)	10 (0.3937)

\*: 4 mm for USAFED-02□□2 and 03□□2  
6 mm for USAFED-05□□2 to 13C□2

### 10.1.3 G Series

#### (1) Standard Type

- Types USAGED-02□□1, -03□□1 (Taper Shaft)

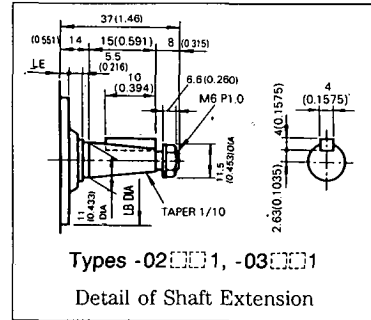
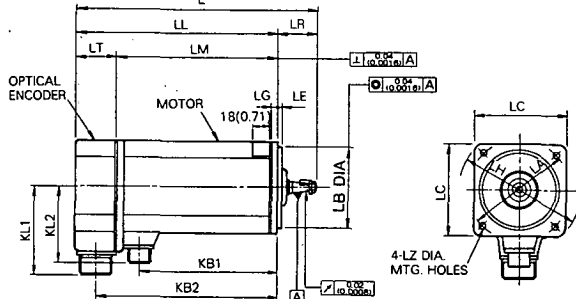

- Types USAGED-05□□1, -09□□1 (Taper Shaft), -13A□2 (Straight Shaft)

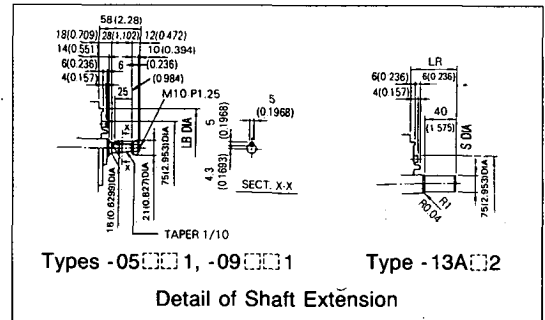
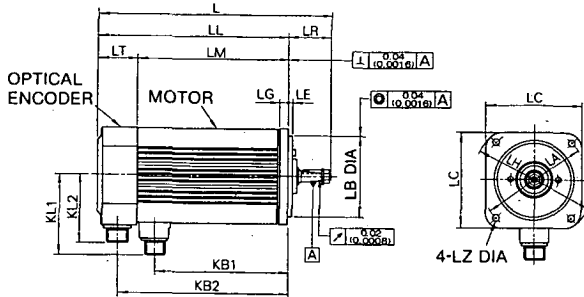

- Types USAGED-20A□2, -30A□2, -44A□2 (Straight Shaft)

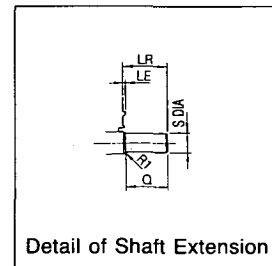
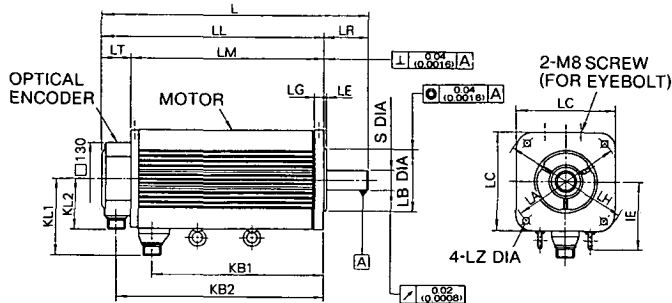

AC SERVO MOTOR Type USAGED-	L	LL	LM	LR	LT	KB1	KB2	IE	KL1	KL2	Flange Surface						Shaft Extension		Approx Mass kg (lb)	
											LA	LB	LC	LE	LG	LH	LZ	S		Q
02□□1*	190 (7.48)	153 (6.02)	113 (4.45)	37 (1.46)	40 (1.57)	90 (3.54)	132 (5.19)	—	76 (3.43)	87 (3.43)	100 (3.94)	80 <sup>+0.030</sup> <sub>-0.012</sub> (3.1496)	90 (3.54)	4 (0.157)	7 (0.276)	120 (4.72)	6.6 (0.26)	—	—	4 (8.8)
03□□1*	236 (9.29)	199 (7.83)	159 (6.26)	37 (1.46)	40 (1.57)	136 (5.35)	178 (7.0)	—	76 (3.43)	87 (3.43)	100 (3.94)	80 <sup>+0.030</sup> <sub>-0.012</sub> (3.1496)	90 (3.54)	4 (0.157)	7 (0.276)	120 (4.72)	6.6 (0.26)	—	—	6 (13.2)
05□□1*	263 (10.35)	205 (8.07)	150 (5.91)	58 (2.28)	55 (2.16)	127 (5.0)	177 (6.97)	—	109 (4.29)	92 (3.62)	145 (5.71)	110 <sup>+0.035</sup> <sub>-0.014</sub> (4.3307)	130 (5.12)	6 (0.24)	12 (0.47)	165 (6.5)	9 (0.35)	—	—	8.5 (18.7)
09□□1*	320 (12.6)	262 (10.32)	207 (8.16)	58 (2.28)	55 (2.16)	184 (7.24)	234 (9.21)	—	109 (4.29)	92 (3.62)	145 (5.71)	110 <sup>+0.035</sup> <sub>-0.014</sub> (4.3307)	130 (5.12)	6 (0.24)	12 (0.47)	165 (6.5)	9 (0.35)	—	—	13 (28.7)
13A□2*	389 (15.31)	331 (13.03)	276 (10.87)	58 (2.28)	55 (2.16)	253 (9.96)	303 (11.93)	—	109 (4.29)	92 (3.62)	145 (5.71)	110 <sup>+0.035</sup> <sub>-0.014</sub> (4.3307)	130 (5.12)	6 (0.24)	12 (0.47)	165 (6.5)	9 (0.35)	22 <sup>+0.013</sup> <sub>-0.005</sub> (0.8661)	40 (15.7)	20 (44.1)
20A□2*	344 (13.54)	265 (10.43)	211 (8.3)	79 (3.11)	54 (2.13)	172 (6.77)	237 (9.33)	—	139 (5.47)	92 (3.62)	200 (7.88)	114.3 <sup>+0.025</sup> <sub>-0.011</sub> (4.5)	180 (7.09)	3.2 (0.13)	18 (0.71)	230 (9.06)	13.5 (0.53)	35 <sup>+0.01</sup> <sub>-0.005</sub> (1.3379)	76 (2.99)	22 (48.5)
30A□2	401 (15.79)	322 (12.68)	268 (10.55)	79 (3.11)	54 (2.13)	229 (9.02)	294 (11.57)	123 (4.85)	139 (5.47)	92 (3.62)	200 (7.88)	114.3 <sup>+0.025</sup> <sub>-0.011</sub> (4.5)	180 (7.09)	3.2 (0.13)	18 (0.71)	230 (9.06)	13.5 (0.53)	35 <sup>+0.01</sup> <sub>-0.005</sub> (1.3379)	76 (2.99)	29 (63.9)
44A□2	486 (19.14)	407 (16.02)	353 (13.90)	79 (3.11)	54 (2.13)	314 (12.36)	379 (14.92)	123 (4.85)	139 (5.47)	92 (3.62)	200 (7.88)	114.3 <sup>+0.025</sup> <sub>-0.011</sub> (4.5)	180 (7.09)	3.2 (0.13)	18 (0.71)	230 (9.06)	13.5 (0.53)	35 <sup>+0.01</sup> <sub>-0.005</sub> (1.3379)	76 (2.99)	41 (90.4)

\* Not provided with an eyebolt.

Notes: 1. The blank □ of motor type depends on class of detectors.

Standard : 2 (8192 P/R)  
Semi-standard: 3 (2048 P/R)

2. Vibration: 15 μm or below.

3. Plug and clamp are not attached for receptacle connection.

4. Connector specifications: Refer to Table 3.8.

5. It is recommended that the motor be mounted with its connector placed down.

## (2) With Brake

- Types USAGED-02□□10E, -03□□10E (Taper Shaft)

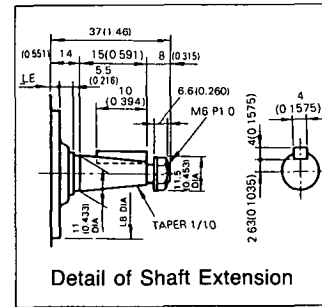
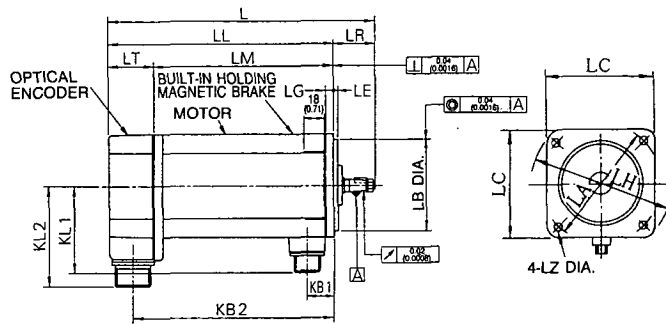

- Types USAGED-05□□10E, -09□□10E (Taper Shaft), -13A□□20E (Straight Shaft)

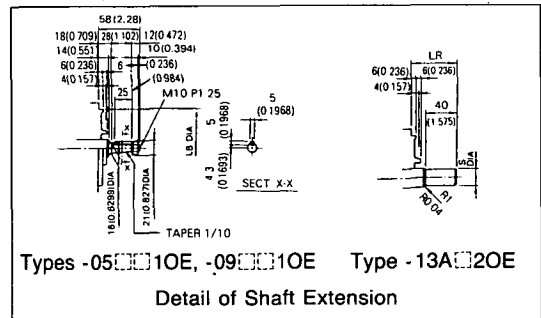
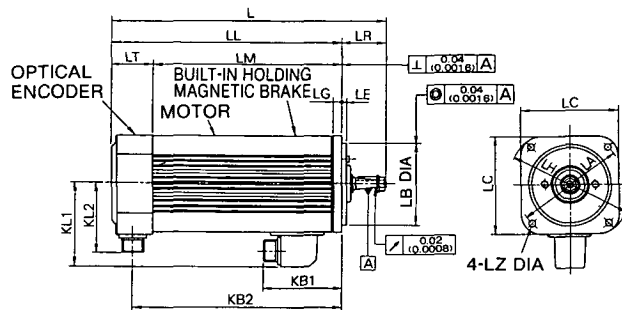

- Types USAGED-20A□□20E, -30A□□20E, -44A□□20E (Straight Shaft)

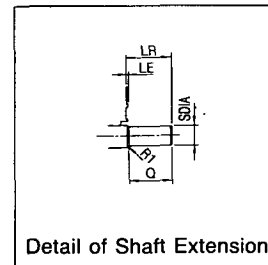
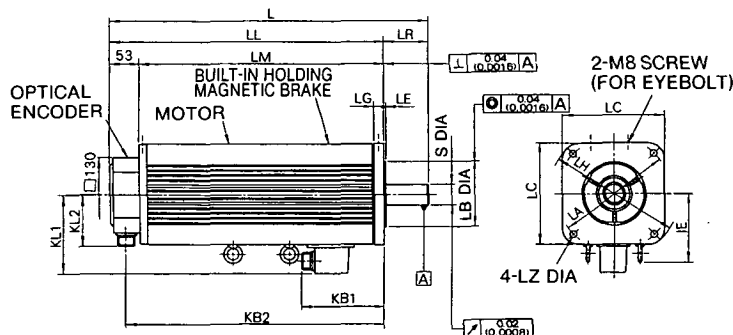

AC SERVO MOTOR Type USAGED-	L	LL	LM	LR	LT	KB1	KB2	IE	KL1	KL2	Flange Surface						Shaft Extension		Approx Mass kg (lb)	BRAKE		
											LA	LB	LC	LE	LG	LH	LZ	S		Q	BRAKING TORQUE N-m (lb-in)	INERTIA (GD <sup>2</sup> /4) kg-m <sup>2</sup> (lb-in <sup>2</sup> )
02□□10E*	236 (9.29)	199 (7.83)	159 (6.26)	37 (1.46)	40 (1.57)	24 (0.95)	178 (7.0)	-	76 (3.43)	87 (3.43)	100 (3.94)	80 (3.1496)	90 (3.54)	4 (0.157)	7 (0.276)	120 (4.72)	6.6 (0.26)	-	-	5 (11.0)	0.98 (8.67)	0.075 × 10 <sup>-4</sup> (0.066 × 10 <sup>-4</sup> )
03□□10E*	286 (11.26)	249 (9.8)	209 (8.23)	37 (1.46)	40 (1.57)	24 (0.95)	228 (8.98)	-	76 (3.43)	87 (3.43)	100 (3.94)	80 (3.1496)	90 (3.54)	4 (0.157)	7 (0.276)	120 (4.72)	6.6 (0.26)	-	-	7 (15.4)	1.96 (13.0)	0.113 × 10 <sup>-4</sup> (0.1 × 10 <sup>-4</sup> )
05□□10E*	320 (12.60)	262 (10.31)	207 (8.15)	58 (2.28)	55 (2.16)	128 (5.04)	234 (9.21)	-	113 (4.45)	92 (3.62)	145 (5.71)	110 (4.3307)	130 (5.12)	6 (0.24)	12 (0.47)	165 (6.5)	9 (0.35)	-	-	11.5 (25.4)	5.88 (52.1)	0.85 × 10 <sup>-4</sup> (0.752 × 10 <sup>-4</sup> )
09□□10E*	366 (14.41)	308 (12.13)	253 (9.97)	58 (2.28)	55 (2.16)	118 (4.65)	280 (11.02)	-	113 (4.45)	92 (3.62)	145 (5.71)	110 (4.3307)	130 (5.12)	6 (0.24)	12 (0.47)	165 (6.5)	9 (0.35)	-	-	15 (33.1)	-	-
13A□□20E*	436 (17.17)	378 (14.89)	323 (12.73)	58 (2.28)	55 (2.16)	118 (4.65)	350 (13.78)	-	113 (4.45)	92 (3.62)	145 (5.71)	110 (4.3307)	130 (5.12)	6 (0.24)	12 (0.47)	165 (6.5)	9 (0.35)	22 (0.8661)	40 (1.57)	23 (50.7)	8.83 (78.1)	0.9 × 10 <sup>-4</sup> (0.797 × 10 <sup>-4</sup> )
20A□□20E*	422 (16.61)	343 (13.50)	289 (11.38)	79 (3.11)	54 (2.13)	164 (6.46)	315 (12.4)	123 (4.85)	143 (5.63)	92 (3.62)	200 (7.88)	114.3 (4.5)	180 (7.09)	3.2 (0.13)	18 (0.71)	230 (9.06)	13.5 (0.53)	35 (1.3379)	76 (2.99)	30 (66.2)	-	-
30A□□20E	486 (19.13)	407 (16.02)	353 (13.90)	79 (3.11)	54 (2.13)	164 (6.46)	379 (14.92)	123 (4.85)	143 (5.63)	92 (3.62)	200 (7.88)	114.3 (4.5)	180 (7.09)	3.2 (0.13)	18 (0.71)	230 (9.06)	13.5 (0.53)	35 (1.3379)	76 (2.99)	37 (81.6)	35.3 (312.5)	6.25 × 10 <sup>-4</sup> (5.53 × 10 <sup>-4</sup> )
44A□□20E	567 (22.32)	488 (19.21)	434 (17.09)	79 (3.11)	54 (2.13)	164 (6.46)	460 (18.11)	123 (4.85)	143 (5.63)	92 (3.62)	200 (7.88)	114.3 (4.5)	180 (7.09)	3.2 (0.13)	18 (0.71)	230 (9.06)	13.5 (0.53)	35 (1.3379)	76 (2.99)	49 (108.1)	-	-

\* Not provided with an eyebolt.

Notes: 1. The blank □ of motor type depends on class of detectors.

Standard : 2 (8192 P/R)  
Semi-standard: 3 (2048 P/R)

2. Vibration: 15 μm or below.

3. Plug and clamp are not attached for receptacle connection.

4. Connector specifications: Refer to Table 3.8.

5. It is recommended that the motor be mounted with its connector placed down.

6. Power supply for brake is 90VDC.

### (3) Shaft Extension of Straight Shaft with Keyway

Both SERVOMOTORS with brake and without brake have the same dimensions except for shaft extension. Shaft extensions are shown below:

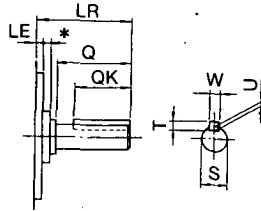

Motor Type		LR	LE	Dimensions of Shaft Extension					
Without Brake	With Brake			S	Q	QK	T	U	W
*USAGED-02□□2K	*USAGED-02□□2KE	37 (1.46)	4 (0.157)	14 (0.5512 $^{+0.011}$ $^{-0.0004}$ )	25 (0.98)	15 (0.59)	5 (0.1968)	3 (0.1181)	5 (0.1968)
*USAGED-03□□2K	*USAGED-03□□2KE	37 (1.46)	4 (0.157)	14 (0.5512 $^{+0.011}$ $^{-0.0004}$ )	25 (0.98)	15 (0.59)	5 (0.1968)	3 (0.1181)	5 (0.1968)
*USAGED-05□□2K	*USAGED-05□□2KE	58 (2.28)	6 (0.24)	19 (0.7480 $^{+0.013}$ $^{-0.0005}$ )	40 (1.57)	25 (0.98)	5 (0.1968)	3 (0.1181)	5 (0.1968)
*USAGED-09□□2K	*USAGED-09□□2KE	58 (2.28)	6 (0.24)	19 (0.7480 $^{+0.013}$ $^{-0.0005}$ )	40 (1.57)	25 (0.98)	5 (0.1968)	3 (0.1181)	5 (0.1968)
*USAGED-13A□2K	*USAGED-13A□2KE	58 (2.28)	6 (0.24)	22 (0.8661 $^{+0.013}$ $^{-0.0005}$ )	40 (1.57)	25 (0.98)	6 (0.2362)	3.5 (0.1378)	6 (0.2362)
USAGED-20A□2K	USAGED-20A□2KE	79 (3.11)	3.2 (0.13)	35 (1.3379 $^{+0.01}$ $^{-0.0004}$ )	76 (2.99)	60 (2.36)	8 (2.2835)	5 (0.1968)	10 (0.3937)
USAGED-30A□2K	USAGED-30A□2KE	79 (3.11)	3.2 (0.13)	35 (1.3379 $^{+0.01}$ $^{-0.0004}$ )	76 (2.99)	60 (2.36)	8 (2.2835)	5 (0.1968)	10 (0.3937)
USAGED-44A□2K	USAGED-44A□2KE	79 (3.11)	3.2 (0.13)	35 (1.3379 $^{+0.01}$ $^{-0.0004}$ )	76 (2.99)	60 (2.36)	8 (2.2835)	5 (0.1968)	10 (0.3937)

\*: 4 mm for USAGED-02□□2 and 03□□2  
6 mm for USAGED-05□□2 to 13A□2

## 10.1.4 D Series

### (1) Standard Type

- Types USADED-05E□2OE to -37E□2OE

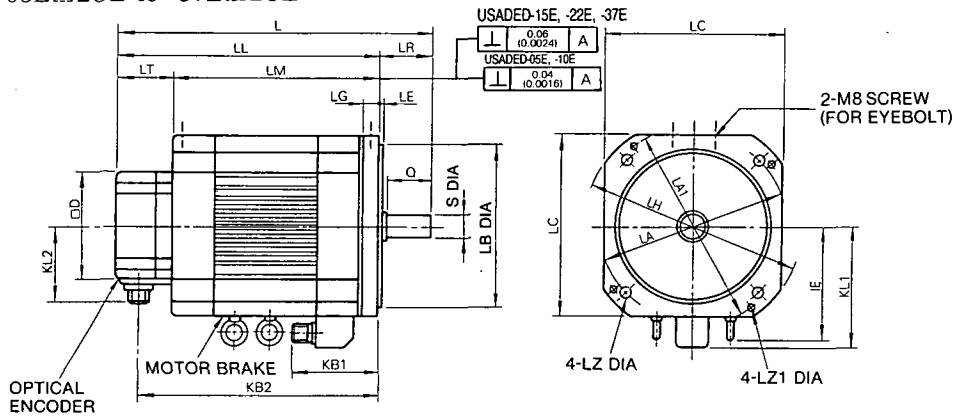

AC SERVMOTOR Type USADED-	L	LL	LM	LR	LT	KB1	KB2	IE	KL1	KL2	D	Flange Surface								Shaft Extension		Approx Mass† kg (lb)	
												LA	LA1	LB	LC	LE	LG	LH	LZ	LZ1	S		Q
05E□2OE*	237 (9.33)	182 (7.17)	137 (5.39)	55 (2.16)	45 (1.77)	82 (3.23)	158 (6.22)	—	143 (5.63)	92 (3.62)	130 (5.12)	200 (7.87)	—	114.3 (4.5)	180 (7.09)	3.2 (0.126)	12 (0.472)	230 (9.06)	13.5 (0.53)	—	22 (0.8661)	50 (1.97)	17 (16) 37.5 (35.3)
10E□2OE*	257 (10.12)	202 (7.96)	157 (6.18)	55 (2.16)	45 (1.77)	82 (3.23)	178 (7.0)	—	143 (5.63)	92 (3.62)	130 (5.12)	200 (7.87)	—	114.3 (4.5)	180 (7.09)	3.2 (0.126)	12 (0.472)	230 (9.06)	13.5 (0.53)	—	22 (0.8661)	50 (1.97)	19 (18) 41.9 (39.7)
15E□2OE	272 (10.71)	217 (8.47)	170 (6.69)	55 (2.16)	47 (1.85)	100 (3.94)	193 (7.60)	142 (5.59)	162 (6.38)	92 (3.62)	130 (5.12)	235 (9.25)	250 (9.84)	200 (7.874)	220 (8.66)	4 (0.157)	16 (0.63)	270 (10.63)	13.5 (0.53)	M8	28 (1.1024)	50 (1.97)	30 (27) 66.2 (59.5)
22E□2OE	287 (11.30)	232 (9.06)	185 (7.28)	55 (2.16)	47 (1.85)	100 (3.94)	208 (8.19)	142 (5.59)	162 (6.38)	92 (3.62)	130 (5.12)	235 (9.25)	250 (9.84)	200 (7.874)	220 (8.66)	4 (0.157)	16 (0.63)	270 (10.63)	13.5 (0.53)	M8	28 (1.1024)	50 (1.97)	32 (29) 70.6 (63.9)
37E□2OE	347 (13.66)	282 (11.02)	235 (9.25)	65 (2.56)	47 (1.85)	100 (3.94)	258 (10.16)	142 (5.59)	162 (6.38)	92 (3.62)	130 (5.12)	235 (9.25)	250 (9.84)	200 (7.874)	220 (8.66)	4 (0.157)	16 (0.63)	270 (10.63)	13.5 (0.53)	M8	32 (1.2598)	60 (2.36)	39 (36) 86 (79.4)

\* Not provided with an eyebolt. †: ( ) shows without brake.

Notes: 1. The blank □ of motor type depends on class of detectors.

Standard : 3 (2048 P/R)

Semi-standard: 2 (8192 P/R)

2. Plug and clamp are not attached for receptacle connection.

3. It is recommended that the motor be mounted with its connector placed down.

4. Both SERVMOTORS with brake and without brake have the same dimension.

5. Connector specification: Refer to Table 3.10.

### (2) Shaft Extension of Straight with Keyway

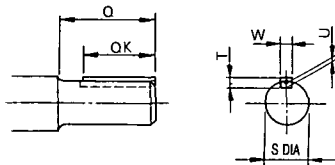

Note: Dimensions of the shaft extension key and keyway are based on JIS (Japanese Industrial Standard) B 1301 "Sunk Keys and Their Corresponding Keyways (Normal keys)." Shaft extension key is furnished.

AC Servomotor Type USADED-	Shaft Extension					
	S	Q	QK	T	U	W
05E□2K□	22 (0.8661)	50 (1.97)	45 (1.77)	6 (0.236)	3.5 (0.138)	6 (0.2362)
10E□2K□	22 (0.8661)	50 (1.97)	45 (1.77)	6 (0.236)	3.5 (0.138)	6 (0.2362)
15E□2K□	28 (1.1024)	50 (1.97)	45 (1.77)	7 (0.275)	4 (0.157)	8 (0.3149)
22E□2K□	28 (1.1024)	50 (1.97)	45 (1.77)	7 (0.275)	4 (0.157)	8 (0.3149)
37E□2K□	32 (1.2598)	60 (2.36)	50 (1.97)	8 (0.315)	5 (0.197)	10 (0.3937)

## 10.1.5 S Series

### (1) Standard Type

- Type USASEM-02A□2 (Straight Shaft)

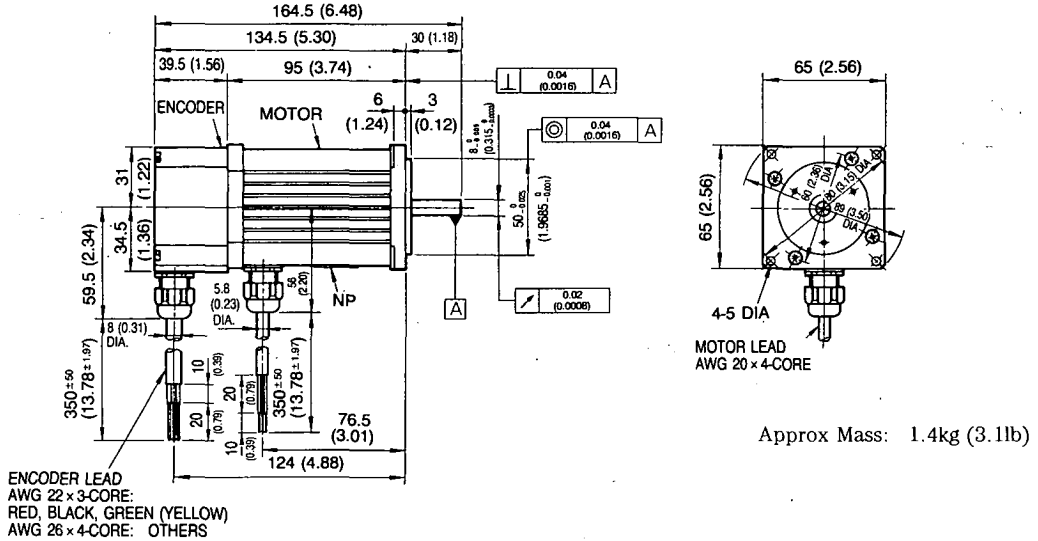

- Notes:
1. The blank □ of motor type depends on class of detectors.  
Standard : 3 (2048 P/R)  
Semi-standard: 4 (2500 P/R)
  2. Vibration: 15μm or below
  3. It is recommended that the motor be mounted with its connector placed down.

- Types USASEM-03A32, -05A32 (Straight shaft)

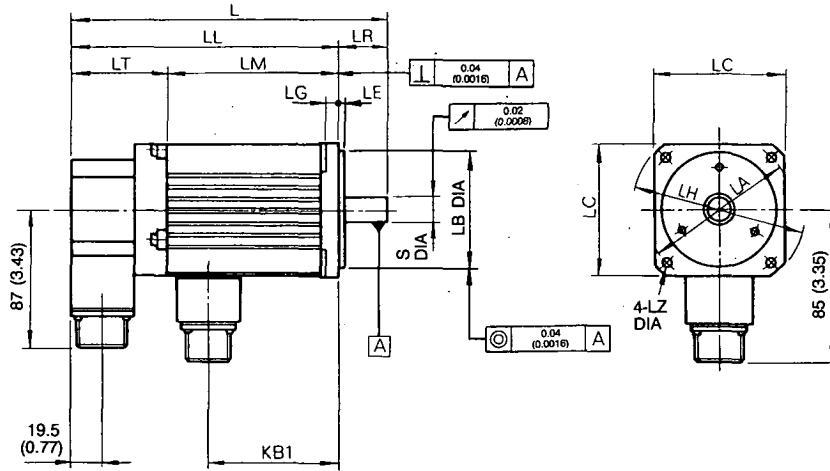

AC SERVO MOTOR Type USASEM-	L	LL	LM	LT	LR	KB1	KL1	Flange Surface and Shaft Extension							Approx Mass kg (lb)	
								LA	LB	LC	LE	LG	LH	LZ		S
03A□2	179 (7.05)	149 (5.87)	110 (4.33)	39 (1.54)	30 (1.18)	78 (3.07)	138 (5.43)	90 (3.54)	70 (2.76)	80 (3.15)	3 (0.12)	8 (0.31)	105 (4.13)	6 (0.24)	14 (0.55)	2.6 (5.7)
05A□2	201 (7.91)	171 (6.73)	132 (5.20)	39 (1.54)	30 (1.18)	100 (3.94)	138 (5.43)	90 (3.54)	70 (2.76)	80 (3.15)	3 (0.12)	8 (0.31)	105 (4.13)	6 (0.24)	14 (0.55)	3.3 (7.3)

- Note:
1. The blank □ of motor type depends on class of detectors.  
Standard : 3 (2048 P/R)  
Semi-standard: 4 (2500 P/R)
  2. Vibration: 15 μm or below
  3. Plug and clamp are not attached for receptacle connection.
  4. It is recommended that the motor be mounted with its connector placed down.
  5. Connector specification: Refer to Table 3.9.





## (2) With Brake

- Types USASEM-02A□2OB, -03A□2OB, -05A□2OB

Motor Type	L	LL	LM	BRAKE			Approx Mass kg (lb)
				INERTIA kg·m <sup>2</sup> (lb·in·s <sup>2</sup> )	BRAKING TORQUE N·m (lb·in)	Voltage V	
USASEM-02A□2OB*	209 (8.23)	179 (7.05)	139.5 (5.49)	$0.0425 \times 10^{-4}$ ( $0.038 \times 10^{-3}$ )	0.98 (8.67)	DC90	2.2 (4.9)
USASEM-03A□2OB	222 (8.74)	192 (7.56)	152.5 (6.0)	$0.175 \times 10^{-4}$ ( $0.156 \times 10^{-3}$ )	1.96 (15.6)	DC90	3.5 (7.7)
USASEM-05A□2OB	244 (9.61)	214 (8.43)	174.5 (6.87)	$0.175 \times 10^{-4}$ ( $0.156 \times 10^{-3}$ )	1.96 (15.6)	DC90	4.1 (9.0)

\*For the detail of dimensions, contact your YASKAWA representative.

- Types USASEM-08A□1OB, -15A□1OB, -30A□1OB

Motor Type	L	LL	LM	BRAKE			Approx Mass kg (lb)
				INERTIA kg·m <sup>2</sup> (lb·in·s <sup>2</sup> )	BRAKING TORQUE N·m (lb·in)	Voltage V	
USASEM-08A□1OB	302 (11.89)	244 (9.61)	193.5 (7.62)	$0.480 \times 10^{-4}$ ( $0.474 \times 10^{-3}$ )	2.94 (26)	DC90	7 (15.4)
USASEM-15A□1OB	385.5 (15.73)	327.5 (12.89)	264 (10.39)	$0.875 \times 10^{-4}$ ( $0.774 \times 10^{-3}$ )	5.88 (52)	DC90	12.5 (27.6)
USASEM-30A□1OB	440 (17.32)	370 (14.57)	306 (12.05)	$0.672 \times 10^{-4}$ ( $0.595 \times 10^{-3}$ )	11.8 (104)	DC90	25.5 (56.2)

## (3) Shaft Extension of Straight

Type USASEM-08A

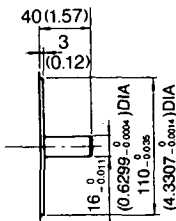

Type USASEM-15A

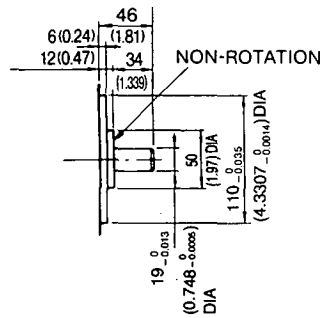

Type USASEM-30A

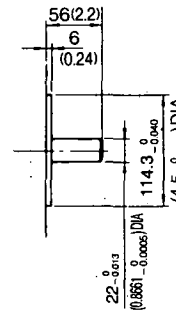

## (4) Shaft Extension of Straight with Keyway

Types USASEM-03A,  
-05A

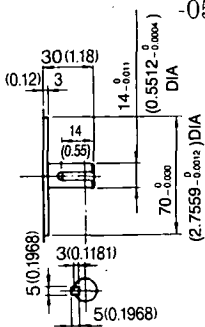

Type USASEM-08A

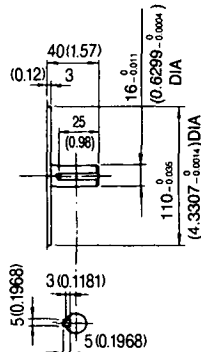

Type USASEM-15A

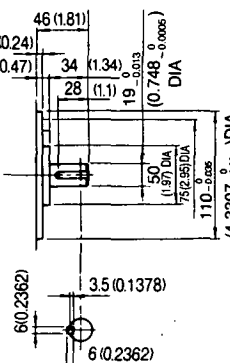

Type USASEM-30A

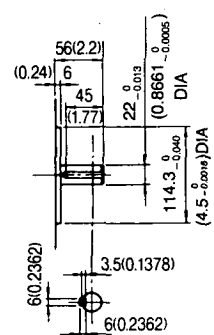

**(5) Shaft Extension of Straight with Shaft Seal**

Types USASEM-03A, -05A

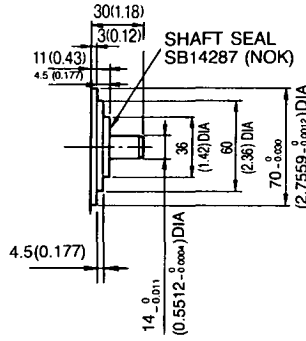

Note: Proper dimensions comply with standard dimensions.

**(6) Shaft Extension of Straight with Key and Shaft Seal**

Types USASEM-03, -05A

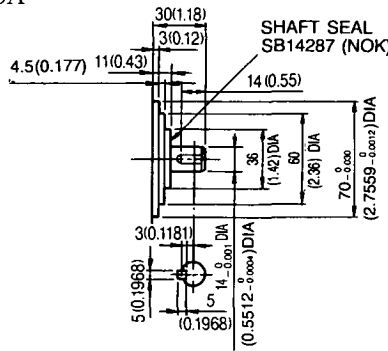

Note: Proper dimensions comply with standard dimensions.

**(7) Shaft Extension of Taper with Shaft Seal**

Type USASEM-08A

Type USASEM-15A

Type USASEM-30A

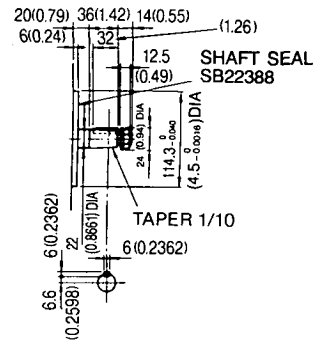
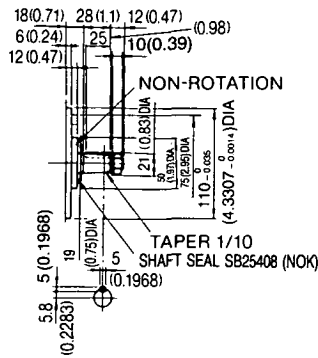
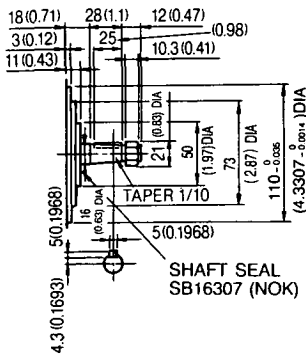

Note: Proper dimensions comply with standard dimensions.

# 10.2 SERVOPACK

Types CACR-SR02BE to -SR15BE

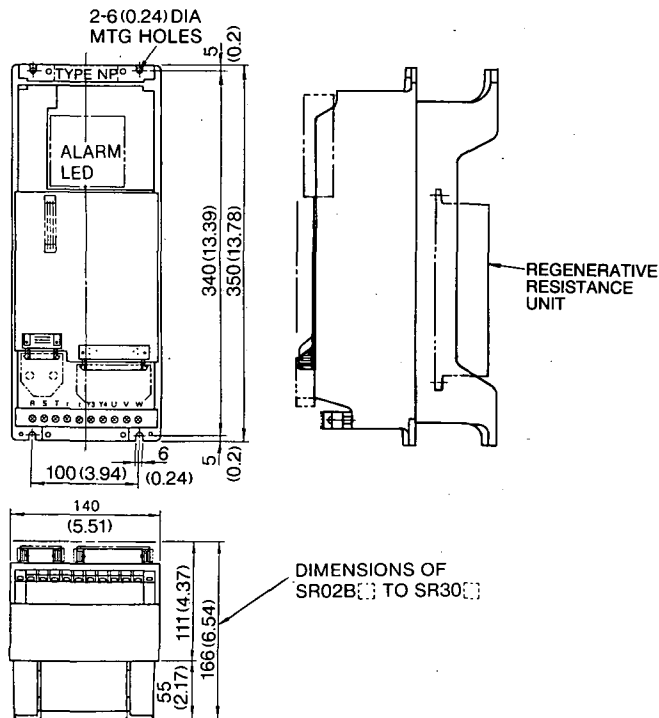

DIMENSIONS OF SR02BE TO SR30

Approx Mass: 6kg (13.2lb)

Types CACR-SR20BE to -SR44BE

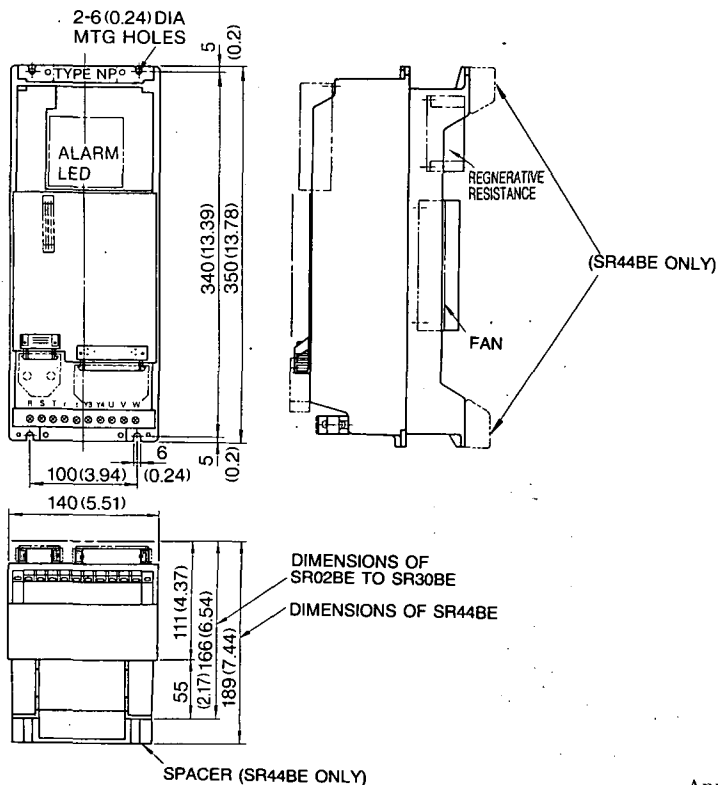

DIMENSIONS OF SR02BE TO SR30BE  
DIMENSIONS OF SR44BE

SPACER (SR44BE ONLY)

Approx Mass: 7kg (15.4lb)

Type CACR-SR60BE

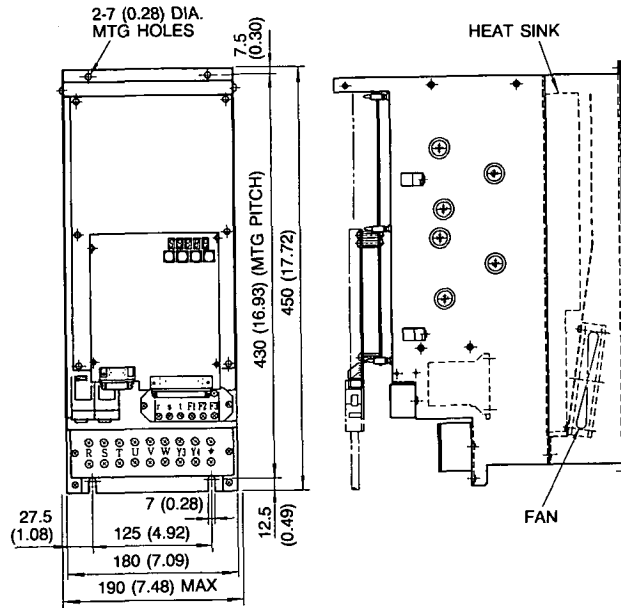

Approx Mass: 13.5kg (29.8lb)

Type CACR-SR□BE1□□-P

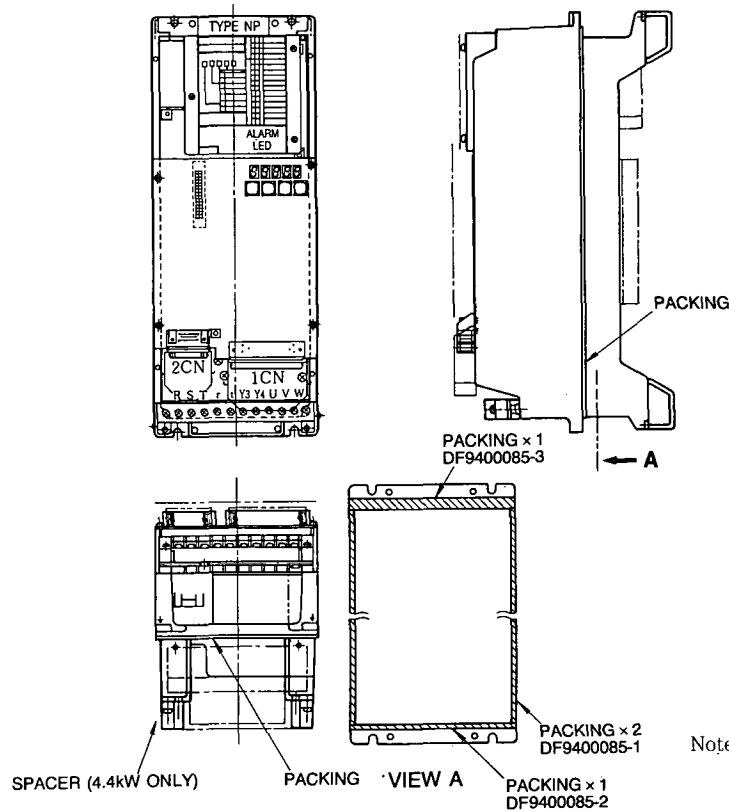

Note: Packing should be attached for duct ventilation.

Type CACR-SR□BE1□□-C

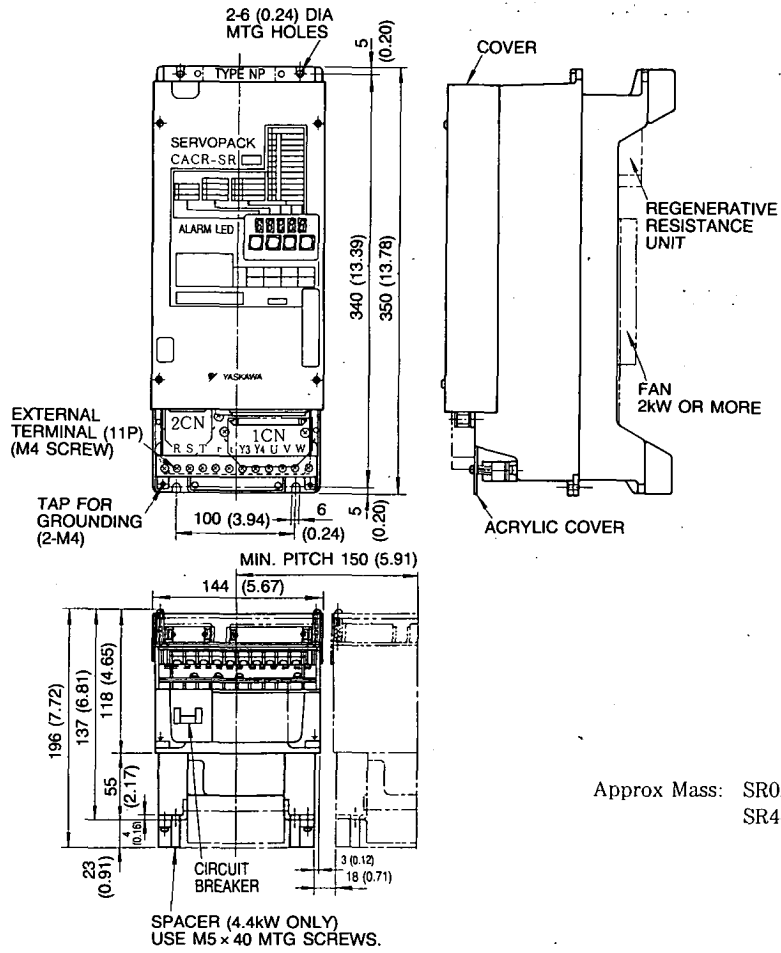

Approx Mass: SR02 to 30BE 6.5kg (14.3lb)  
SR44BE 7.5kg (16.5lb)

## 10.3 PERIPHERAL DEVICES in mm (inches)

### (1) Variable Resistor for Speed Setting

Type 25HP-10B

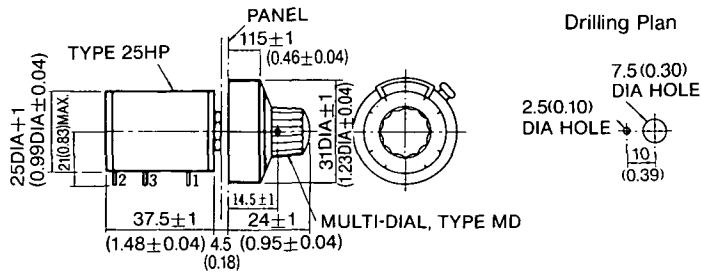

### (2) Power Supply for Brake

#### (a) Standard Type

- Input 100 VAC, 90 VDC, Max. 1.0 ADC (Type B9400876-2) Type: LPDE-1H01
- Input 200 VAC, 90 VDC, Max. 1.0 ADC (Type B9400876-1) Type: LPSE-2H01

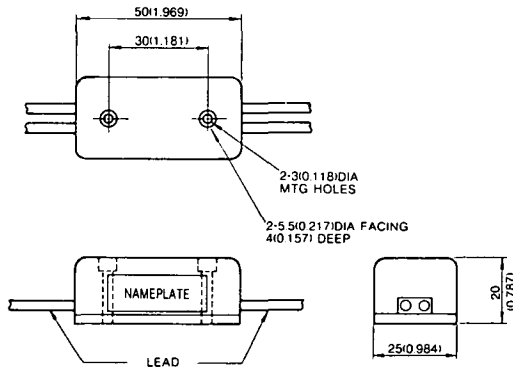

Lead length: 500mm (19.69 in) each  
Lead color

AC Input Side		Brake Side
100V	200V	
Blue	Yellow	Red
White	White	Black

#### • For 100 VAC

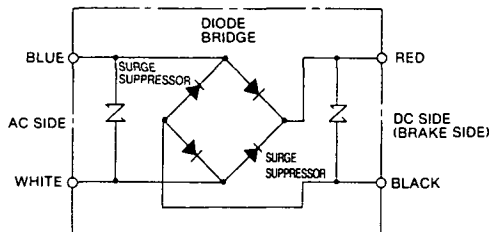

#### • For 200 VAC

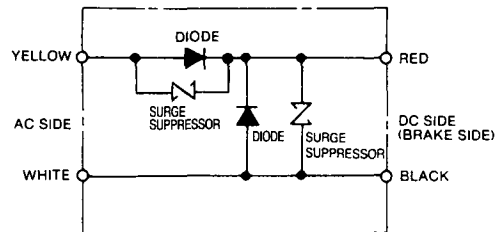

Note: The brake power circuit can be turned ON and OFF on either the AC or DC side. Normally, switching on the AC side is safer. If switched on the DC side, surge voltage may damage the brake coil. To avoid this, place a surge suppressor near the brake coil.

(b) Conventional Type

(Type OPR109F) (Type OPR109A)

- Input 100 VAC, output 90 VDC, Max. 1.0 ADC (Type OPR109F)
- Input 200 VAC, output 90 VDC, Max. 1.0 ADC (Type OPR109A)

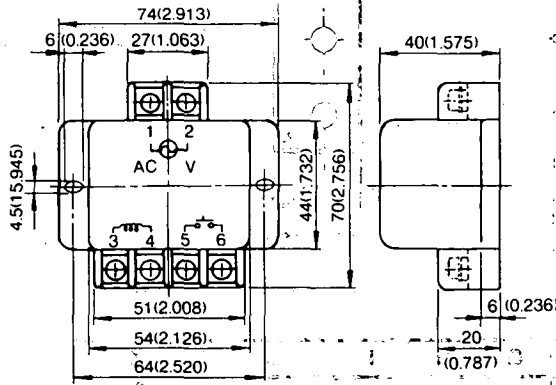

Type OPR109F Circuit Diagram

Type OPR109A Circuit Diagram

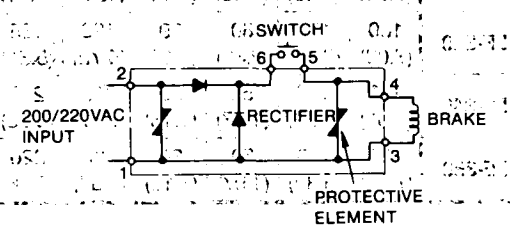
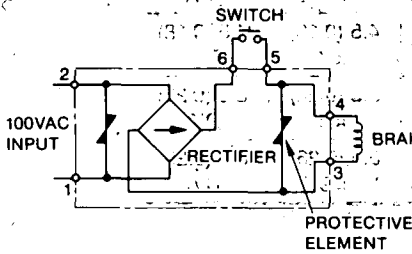

Notes:

1. Do not short-circuit between output terminal Nos. 3 and 4.
2. The open/close value of the contact used for Nos. 5 and 6 is 5 to 10 times the rated current of the brake used.  
Direct current open/close contacts must be used.
3. Insert a fuse in the input-side to protect the power unit.

Fuse Type: MF60 NR2  
(Made by TOYO FUSE CO., LTD.)

Circuit Diagram

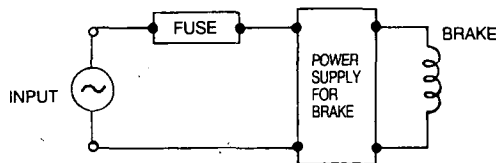

(3) Noise Filter (Made by Tokin Corp.)

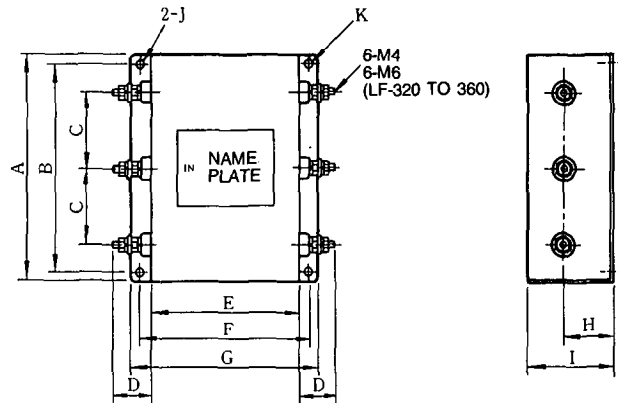

Type	A	B	C	D	E	F	G	H	I	J	K
LF-305	120 (4.72)	110 (4.33)	40 (1.57)	25 (0.98)	80 (3.15)	95 (3.74)	110 (4.33)	25 (0.98)	45 (1.77)	4.5 (0.18) × 7	4.5 (0.18) DIA
LF-310	180 (7.09)	170 (6.69)	60 (2.36)	25 (0.98)	120 (4.72)	135 (5.31)	150 (5.91)	35 (1.38)	65 (2.56)	4.5 (0.18) × 7	4.5 (0.18) DIA
LF-315	180 (7.09)	170 (6.69)	60 (2.36)	25 (0.98)	120 (4.72)	135 (5.31)	150 (5.91)	35 (1.38)	65 (2.56)	4.5 (0.18) × 7	4.5 (0.18) DIA
LF-320	180 (7.09)	170 (6.69)	60 (2.36)	29 (1.14)	120 (4.72)	135 (5.31)	150 (5.91)	35 (1.38)	65 (2.56)	4.5 (0.18) × 7	4.5 (0.18) DIA
LF-330	180 (7.09)	170 (6.69)	60 (2.36)	29 (1.14)	120 (4.72)	135 (5.31)	160 (6.30)	35 (1.38)	65 (2.56)	4.5 (0.18) × 7	4.5 (0.18) DIA
LF-340	180 (7.09)	160 (6.30)	50 (1.97)	30 (1.18)	200 (7.87)	220 (8.66)	240 (9.45)	40 (1.57)	80 (3.15)	6.5 (0.26) × 9	6.5 (0.26) DIA
LF-350	180 (7.09)	160 (6.30)	50 (1.97)	30 (1.18)	200 (7.87)	220 (8.66)	240 (9.45)	50 (1.57)	80 (3.15)	6.5 (0.26) × 9	6.5 (0.26) DIA



## 11. TEST RUN

Before test run, check the following. Correct any deficiency.

### 11.1 CHECK ITEMS BEFORE TEST RUN

#### 11.1.1 SERVOMOTOR

Before test run, check the following. If the test run is performed after long storage, see Par.13 "INSPECTION AND MAINTENANCE"

- Connection to machines or devices, wiring and grounding are correct.
- Bolts and nuts are tightened.
- For motors with shaft seals, the seals are not damaged and shaft is properly lubricated.

#### 11.1.2 SERVOPACK

- Setting parameters are correctly set to satisfy the specifications for the applicable SERVOMOTOR.
- Connection and wiring leads are firmly connected to terminals or inserted into the connectors.
- The power supply is turned OFF if servo alarm occurs.
- Voltage supplied to SERVOPACK is 200 to 230V  $\pm 10\%$ .  
If a voltage line other than 200V is used, the voltage should be dropped to 200V through a power transformer.
- The speed reference should be 0V.
- MCCB on the SERVOPACK is ON. (See Fig. 11.1)

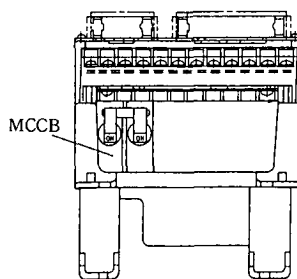

Fig. 11.1 Location of MCCB

## 11.2 TEST RUN PROCEDURES

### 11.2.1 Preparation for Operation

During test run, loads should not be applied to the SERVOMOTOR. If it is necessary to start with the driven machine connected to the motor, confirm that the driven system is ready for emergency stop at any time.

(1) Power ON

After checking items in par. 11.1, turn ON the power supply. When the power ON sequence is correct, according to Par. 6.1, the power is turned ON by depressing the POWER pushbutton for approximately 1 second.

(2) When the power is correctly supplied, the following five figures LED s light. (This display appears when the motor stops.)



(3) When a S-ON signal is input (contact is on), the power circuit in the SERVOPACK operates and the motor is ready to drive. (This display appears when the motor stops.)



### 11.2.2 Operation

The operation is possible only while "S-ON" signal is ON.

(1) Increase the speed reference voltage gradually from 0V, then the motor rotates at a speed proportional to the reference voltage.



(2) When the reference voltage is positive, the motor rotates in the forward direction (counterclockwise when viewed from the shaft extension.) (Fig. 11.2)

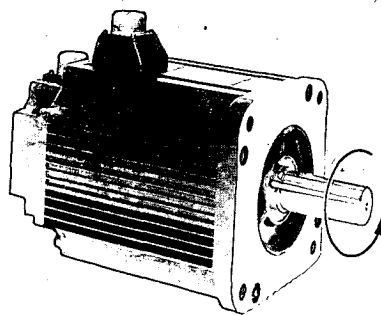

Fig. 11.2 Motor Forward Running

### 11.2.3 Inspection during Test Run

The following items should be checked during the test run.

- Unusual vibration
- Abnormal noise
- Excessive temperature rise

If any fault is found, take corrective actions according to Par. 14. At a test operation, the load and machine may not fit well at first and result in overload.

## 12. ADJUSTMENT

### 12.1 CHARACTERISTICS PRESET AT THE FACTORY PRIOR TO SHIPMENT

SERVOPACK has been factory-adjusted as follows:

(1) Speed Reference Input-SERVOMOTOR Speed Ratio (Fig. 12.1)

Condition: No load

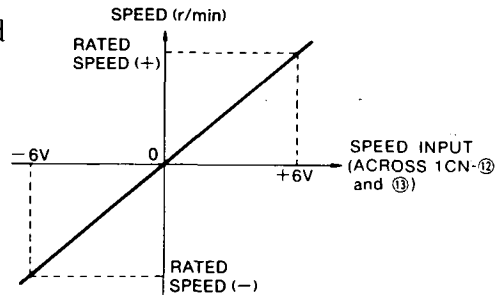

Fig. 12.1 Speed Reference Input-SERVOMOTOR Speed Ratio

(2) Speed Regulation (Fig. 12.2)

Speed regulation  $\Delta N, \Delta n$

$$\frac{\Delta N}{N_R} \times 100 \% \leq 0.01 \%$$

$$\frac{\Delta n}{N_R} \times 100 \% \leq 0.01 \%$$

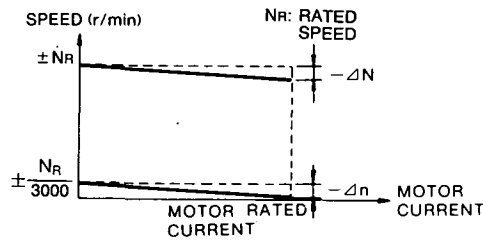

Fig. 12.2 Speed Regulation

(3) Start-stop Response Characteristics (Fig. 12.3)

$I_p$ : Start current set value in Table 12.1. The overshoot ( $\Delta N_{ov}$ ) and undershoot ( $\Delta N_{ud}$ ) when  $J_L = J_M$ , are as shown in Table 12.1 (adjustment level preset at the factory).

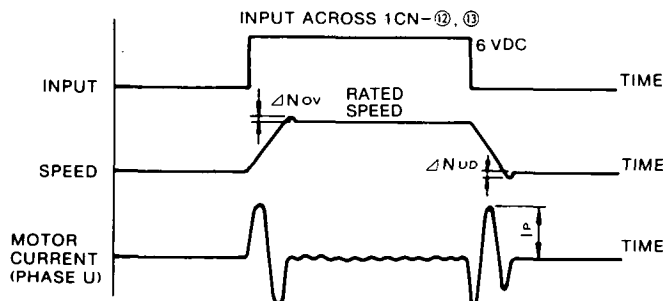

Fig. 12.3 Start-Stop Response Characteristics

Table 12.1 Overshoot and Undershoot at Step Response

Type CACR-	$N_{ov}/N_R \times 100$	$N_{ud}/N_R \times 100$
SR02BE	5 % max	5 % max
SR03BE		
SR05BE		
SR07BE		
SR10BE		
SR15BE		
SR20BE		
SR30BE		
SR44BE		
SR60BE		

## 12.2 READJUSTMENT

SERVOPACK has been adjusted at the factory to obtain optimum characteristics, and readjustment is normally unnecessary. If adjustment is required depending on the use, readjust the SERVOPACK referring to Par.8, "MONITOR PANEL OPERATION".

## 13. INSPECTION AND MAINTENANCE

### 13.1 AC SERVOMOTOR

The AC SERVOMOTOR has no wearing parts (eg. brushes), so simple daily inspection is sufficient. The inspection schedule for the motor is shown in **Table 13.1**.

Do not disassemble the motor. If disassembly is necessary, contact your YASKAWA representative.

**Table 13.1 Inspection Schedule for Motors**

Inspection Item	Frequency	Inspection Operation	
Vibration	Daily	Feel manually	If abnormal vibration or noise is found, contact your YASKAWA representative.
Noise		Aurally	
Exterior and Cleaning	As required	Clean with dry cloth or compressed air.	
Insulation Resistance	Annually	Make sure that it is more than 10M $\Omega$ by measuring with a 500V megger after disconnecting the motor from the controller.	
Shaft Seal	Every 5,000 hours	Replace shaft seal.	
Overhaul	Every 20,000 hours or 5 years	If worn or damaged, replace after disconnecting the motor from the driven machine. Contact your YASKAWA representative.	

#### • Parts Replacement Schedule

The following parts should be replaced periodically since they may become worn mechanically.

**Table 13.2 Parts Replacement Schedule**

Part Name	Interval	Remarks
Bearing	20,000 hours	Disassemble the motor to replace with new one.
Shaft Seal	5,000 hours	Replace with new one.

## 13.2 SERVOPACK

SERVOPACK does not require any daily maintenance. However, it is advisable to perform the following maintenance at least once a year.

However, when the SERVOPACK is overhauled by YASKAWA, check the user constants before running since they are reset to the standard setting.

Table 13.3 Inspection Schedule for SERVOPACK

Inspection Item	Frequency	Operation	Corrective Action
Cleaning of SERVOPACK and board	Every 1 year	Visually check for dust or oil on parts.	Clean with dry cloth or compressed air.
Loose screws		Check for loose screws of terminals and connectors of 1CN and 2CN of SERVOPACK.	Retighten.
Deterioration of SERVOPACK and/or parts on board		Visually check for discoloration, breakage or disconnection resulting from heat, bumping, etc.	Contact your YASKAWA representative.
Cooling fan		Check if the fan rotates normally.	

### • Parts Replacement Schedule

The following parts should be replaced periodically since they may become worn mechanically or deteriorated with age.

Table 13.4 Parts Replacement Schedule

Part Name	Interval	Remarks
Fuse	10 years	Replace with new one.
Smoothing capacitor	7 to 8 years	Replace with new one. (Decided after inspection)
Circuit protector or relays	—	Upon inspection, decided whether they should be replaced.
Cooling fan	2 to 3 years	Replace with new one.
Aluminum electrolytic capacitor on PC board	10 years	Replace with new one. (Decided after inspection)

Note: Optimum operating environment is as follows:

Ambient temperature: 30°C on average

Load factor: 80% or less

Operating rate: 20 hours or less per day

# 14. TROUBLESHOOTING

## 14.1 SERVOMOTOR

### WARNING

Corrective actions in  should be performed after turning OFF the power.

Table 14.1 Troubleshooting Guide for AC Servomotor

Trouble	Cause	What to do
Motor does not start.	Loose connection	Tighten connection.
	Wrong wiring	Correct wiring.
	Overload	Reduce load or use a larger motor.
Unstable operation	Wrong wiring	Inspect and correct wiring across motor terminals U, V, and W, and PG.
Motor overheats.	Excessive ambient temperature.	Reduce ambient temperature below 40°C.
	Motor surface is dirty.	Clean motor surface.
	Overload	Reduce load or use a larger motor.
Unusual noise	Motor loosely mounted	Tighten foundation bolts.
	Motor misaligned	Realign with driven machine.
	Coupling out of balance	Balance coupling.
	Noisy bearing	Check alignment, noise of bearing, lubrication and contact your YASKAWA representative.
	Vibration of driven machine	Contact the machine manufacturer.

## 14.2 SERVOPACK

### 14.2.1 LED Indication (7-segment) for Troubleshooting

Table 14.2 LED Indication for Troubleshooting

LED Display (Traceback Monitor)	Lighting Condition	Probable Cause	Corrective Actions
<b>R. 10</b>	Goes ON when power is supplied to the control circuit	Defective control circuit board (1 PWB).	• Replace the SERVOPACK.
Overcurrent or overheat	Goes ON when power is supplied to the main circuit and servo power is turned ON. • MCCB does not trip.	<ul style="list-style-type: none"> <li>• Defective current feedback circuit.</li> <li>• Defective main circuit transistor module.</li> <li>• Motor grounding</li> </ul>	<ul style="list-style-type: none"> <li>• Replace the SERVOPACK.</li> <li>• Correct grounding</li> </ul>
	Goes ON when power is supplied to the main circuit.	• Defective main circuit transistor module.	• Replace the SERVOPACK. (Don't turn ON the power again.)
	Goes ON during operation. • When power to the control circuit is turned OFF and then turned ON again. When reset later, the operation starts.	• Fan has stopped.	• Check whether the fan rotates. (SR20, 30, 44, 60)
		• Temperature around the SERVOPACK exceeds 55°C.	• Reduce ambient temperature around the SERVOPACK to 55°C or lower (Heat sink overheat.)
<b>R. 20</b>	Goes ON when power is supplied to the control circuit.	• Defective control circuit board (1PWB).(MCCB is ON status.)	• Replace the SERVOPACK.
Circuit protector tripped	Goes ON when power is supplied to the main circuit.	• Defective main circuit thyristor diode module.	• Replace the SERVOPACK. (Don't turn ON the power again.)
		• MCCB is ON.	• Replace the SERVOPACK.
		• MCCB is OFF.	• Turn ON the MCCB.
<b>R. 30</b>	Goes ON when power is supplied to the control circuit.	• Defective control circuit board. (1 PWB).	• Replace the SERVOPACK.
Regenerative fault	Goes ON approximate 0.5 to 1 second after power is supplied to the main circuit.	• Defective regenerative transistor.	• Replace the SERVOPACK.
		• Regenerative resistor is disconnected or not connected. (SR60BE)	• Check and replace the regenerative resistor. (Replace the SERVOPACK.)
<b>R. 40</b>	Goes ON when the motor accelerates or decelerates.	• Load inertia $J_L(GD)^2$ is too large.	• Check the inertia of the machine with the value at the motor output shaft.
Overvoltage		• Defective regenerative circuit.	• Replace the SERVOPACK.
<b>R. 51</b>	When the reference is input, the motor runs fast and LED goes ON.	<ul style="list-style-type: none"> <li>• Motor connection error.</li> <li>• Optical encoder connection error.</li> <li>• Improper gain adjustment</li> </ul>	<ul style="list-style-type: none"> <li>• Correct the motor connection.</li> <li>• Check pulses in phases A, B, C on 2CN, and correct wiring.</li> <li>• Correct gains</li> </ul>
<b>R. 60</b>	Goes ON when power is supplied to the main circuit.	• Defective main circuit thyristor-diode module.	• Replace the SERVOPACK.
Undervoltage			
<b>R. 71</b>	Goes ON during operation. • When power to the control circuit is turned OFF and then turned ON again, the operation starts.	• Operation is continued for several seconds to several tens seconds at a torque exceeding the rating.	• Check for overload and adjust as necessary.
Instantaneous overload			
<b>R. 72</b>	Goes ON when power is supplied to the control circuit.	• Defective control circuit board (1 PWB).	• Replace the SERVOPACK.
Continuous overload	The motor rotates, but the torque is unavailable. When power to the control circuit is turned OFF and then turned ON again, the operation starts, but the torque is still unavailable.	• Motor circuit wrong connection, such as U→V, V→W, W→U or single-phase connection.	• Correct wiring.



Table 14.2 LED Indication for Troubleshooting (Cont'd)

LED Display (Traceback Monitor)	Lighting Condition	Probable Cause	Corrective Actions
<b>A. b1</b> External current limit read error	Goes ON during operation.	<ul style="list-style-type: none"> <li>• Erroneous operation with the external current limit reader.</li> <li>• Failure of the external current limit reader.</li> </ul>	<ul style="list-style-type: none"> <li>• Resume after resetting operation.</li> <li>• Replace the SERVOPACK.</li> </ul>
<b>A. b2</b> Reference read error	Goes ON during operation.	<ul style="list-style-type: none"> <li>• Erroneous operation with the reference input reader.</li> <li>• Failure of the external reference input reader.</li> </ul>	<ul style="list-style-type: none"> <li>• Resume after resetting operation.</li> <li>• Replace the SERVOPACK.</li> </ul>
<b>A. c1</b> Overrun detection	Goes ON when the motor starts momentarily.	<ul style="list-style-type: none"> <li>• Motor connection error.</li> <li>• Optical encoder connection error.</li> </ul>	<ul style="list-style-type: none"> <li>• Correct the motor connection.</li> <li>• Correct wiring of the optical encoder.</li> </ul>
<b>A. c2</b> Phase detection error	Goes ON when the motor starts momentarily.	<ul style="list-style-type: none"> <li>• Optical encoder connection error.</li> </ul>	<ul style="list-style-type: none"> <li>• Correct signal cables of the optical encoder.</li> </ul>
<b>A. c3</b> Phase PA,PB disconnection	Goes ON when the motor starts momentarily.	<ul style="list-style-type: none"> <li>• Phase A and B of optical encoder disconnection (PA, PB)</li> </ul>	<ul style="list-style-type: none"> <li>• Correct signal cables of the optical encoder.</li> </ul>
<b>A. c4</b> Phase PC disconnection	Goes ON when the motor starts momentarily.	<ul style="list-style-type: none"> <li>• Phase PC of optical encoder disconnection.</li> </ul>	<ul style="list-style-type: none"> <li>• Correct signal cables of the optical encoder.</li> </ul>
<b>A. F1</b> Open phase of power supply	Goes ON when power is supplied to the main circuit.	<ul style="list-style-type: none"> <li>• Open phase of power supply.</li> </ul>	<ul style="list-style-type: none"> <li>• Check the main circuit power supply.</li> </ul>
<b>A. F2</b> Power supply rise error	Goes ON when power is supplied to the main circuit.	<ul style="list-style-type: none"> <li>• Large distortion of power supply.</li> </ul>	<ul style="list-style-type: none"> <li>• Check the main circuit power supply.</li> </ul>
<b>A. 02</b> Parameter breakdown	Goes ON when power is supplied to the control circuit.	<ul style="list-style-type: none"> <li>• Defective control circuit board. (1PWB, 2PWB)</li> </ul>	<ul style="list-style-type: none"> <li>• Replace the SERVOPACK.</li> </ul>
<b>A. 03</b> Main detection error	Goes ON when power is supplied to the control circuit.	<ul style="list-style-type: none"> <li>• Defective control circuit board (1PWB, 2PWB)</li> </ul>	<ul style="list-style-type: none"> <li>• Replace the SERVOPACK.</li> </ul>
	Goes ON during operation.	<ul style="list-style-type: none"> <li>• Malfunction of the internal circuit.</li> <li>• Failure of the internal circuit.</li> </ul>	<ul style="list-style-type: none"> <li>• Resume after resetting operation.</li> <li>• Replace the SERVOPACK.</li> </ul>
<b>A. 04</b> Parameter setting error	Goes ON during parameter charge.	<ul style="list-style-type: none"> <li>• Set the value without a setting range.</li> </ul>	<ul style="list-style-type: none"> <li>• Reset the parameter.</li> </ul>
-	Goes ON when power is supplied to the control circuit.	<ul style="list-style-type: none"> <li>• Defective control circuit board (1 PWB).</li> </ul>	<ul style="list-style-type: none"> <li>• Replace the SERVOPACK.</li> </ul>
	Goes ON during operation.	<ul style="list-style-type: none"> <li>• Faulty internal elements.</li> <li>• Defective internal elements.</li> </ul>	<ul style="list-style-type: none"> <li>• Resume after resetting operation.</li> <li>• Replace the SERVOPACK.</li> </ul>
	No display at control power ON.	<ul style="list-style-type: none"> <li>• Power fault</li> </ul>	<ul style="list-style-type: none"> <li>• Replace the SERVOPACK.</li> </ul>
		<ul style="list-style-type: none"> <li>• Control power is not supplied properly.</li> </ul>	<ul style="list-style-type: none"> <li>• Supply the control power properly.</li> </ul>
<b>A. 99</b> A.99	(Traceback data)	<ul style="list-style-type: none"> <li>• Retained at alarm reset and control power ON. (No fault)</li> </ul>	

Note: CPU faults are not recorded in traceback data.

## 14.2.2 Examples of Troubleshooting for Defective Wiring or Parts

Table 14.3 Example of Troubleshooting for Defective Wiring or Parts

Trouble	Check Items	Corrective Actions
MCCB trips immediately after Power ON and Servo ON.	• Main circuit wiring (such as motor grounding)	• Correct the wiring.
The reference is input, but the motor does not run.	<ul style="list-style-type: none"> <li>• Voltage across (R), (S), and (T).</li> <li>• Alarm LED OFF</li> <li>• Speed reference voltage</li> <li>• P-CON, N-OT, P-OT, S-ON, SEN signals</li> <li>• LED <input type="checkbox"/> <input type="checkbox"/> <input type="checkbox"/> <input type="checkbox"/> <input type="checkbox"/> ON</li> </ul>	<ul style="list-style-type: none"> <li>• Check the AC power supply circuit.</li> <li>• If LED is ON, check the cause.</li> <li>• Adjust the speed setting potentiometer (supplied by user.)</li> </ul>

## 14.2.3 Examples of Errors Resulting Setting Errors

Table 14.4 Examples of Errors Resulting Setting Errors

Error Cause	Cause	Corrective Actions
The motor vibrates at a high frequency of about 200 to 300 Hz.	Speed loop gain is too high (influence by induced noise in the SERVOPACK input circuit since the cable is too long or is bundled together with a power line.)	Adjust Cn-04 [LOOP Hz] to reduce speed loop gain until vibration stops. Separate the input circuit cable from the power lines or receive power to the input circuit from a power supply of a lower impedance (about 100Ω or lower. AC is allowable.)
Too much overshoot is observed with the rotation speed at acceleration and deceleration.	Speed loop gain is too high.	Adjust Cn-04 [LOOP Hz] to reduce speed loop gain until vibration stops.
The motor runs even when speed reference voltage is 0V.	There is an offset to the speed reference voltage.	Adjust the offset to the speed reference voltage. (See Par. 8.4.4, "Speed Reference Offset Adjustment.")

NOTES

# AC SERVO DRIVES BULLETIN

TOKYO OFFICE Ohtemachi Bldg, 1-6-1 Ohtemachi, Chiyoda-ku, Tokyo, 100 Japan  
Phone (03) 3284-9111 Telex YASKAWA J33530 Fax (03) 3284-9034

**YASKAWA ELECTRIC AMERICA, INC.**

Chicago-Corporate Headquarters 2942 MacArthur Blvd. Northbrook, IL 60062-2028, U.S.A.

Phone (708) 291-2340 Fax (708) 498-2430

Chicago-Technical Center 3160 MacArthur Blvd. Northbrook, IL 60062-1917, U.S.A.

Phone (708) 291-0411 Fax (708) 291-1018

**MOTOMAN INC.**

805 Liberty Lane West Carrollton, OH 45449, U.S.A.

Phone (513) 847-6200 Fax (513) 847-6277

**YASKAWA ELÉTRICO DO BRASIL COMÉRCIO LTDA.**

Avenida Brigadeiro Faria Lima 1664-5°CJ 504/511, São Paulo, Brazil

Phone (011) 825-7723 Fax (011) 210-9781

**YASKAWA ELECTRIC EUROPE GmbH**

Am Kronberger Hang 2, 65824 Schwalbach, Germany

Phone (49) 6196-569-300 Fax (49) 6196-888-301

**Motoman Robotics AB**

Box 504 S38525, Torsås, Sweden

Phone 0486-10575 Fax 0486-41410

**Motoman Robotec GmbH**

Kammerfeldstraße 1, 85391 Allershausen, Germany

Phone 08166-900 Fax 08166-9039

**YASKAWA ELECTRIC UK LTD.**

3 Drum Mains Park Orchardton Woods Cumbernauld, Scotland, G68 9LD U.K.

Phone (1236)735000 Fax (1236)458182

**YASKAWA ELECTRIC KOREA CORPORATION**

Paik Nam Bldg. 901 188-3, 1-Ga Euljiro, Joong-Gu Seoul, Korea

Phone (02)776-7844 Fax (02)753-2639

**YASKAWA ELECTRIC (SINGAPORE) PTE. LTD.**

Head Office : CPF Bldg, 79 Robinson Road #13-05, Singapore 068897, SINGAPORE

Phone 221-7530 Telex (87) 24890 YASKAWA RS Fax 224-5854

Service Center : 221 Henderson Road, # 07-20 Henderson Building Singapore 159557, SINGAPORE

Phone 276-7407 Fax 276-7406

**YATEC ENGINEERING CORPORATION**

Shen Hsiang Tang Sung Chiang Building 10F 146 Sung Chiang Road, Taipei, Taiwan

Phone (02) 563-0010 Fax (02) 567-4677

**SHANGHAI OFFICE** Room No. 8B Wan Zhong Building 1303 Yan An Road (West), Shanghai 200050, CHINA

Phone (86) 212-1015 Fax (86) 212-1015

**TAIPEI OFFICE** Shen Hsiang Tang Sung Chiang Building 10F 146 Sung Chiang Road, Taipei, Taiwan

Phone (02) 563-0010 Fax (02) 567-4677



YASKAWA ELECTRIC CORPORATION

YASKAWA

TSE-S800-11.1E

© Printed in Japan December 1995 91-3 4WA  
390-28, 592-75

*Due to ongoing product modification/improvement, data subject to change without notice.*